

MARKS PUBLISHED FOR OPPOSITION

The following marks are published in compliance with section 12(a) of the Trademark Act of 1946. Applications for the registration of marks in more than one class have been filed as provided in section 30 of said act as amended by Public Law 772, 87th Congress, approved Oct. 9, 1962, 76 Stat. 769. Opposition under section 13 may be filed within thirty days of the date of this publication. See rules 2.101 to 2.105.

A separate fee of three hundred dollars (\$300.00) for opposing each mark in each class must accompany the opposition.

SECTION 1.— INTERNATIONAL CLASSIFICATION

The short titles associated below with the international class numbers are terms designed merely for quick identification and are not an official part of the international classification. The full names of international classes are given in section 6.1 of the trademark rules of practice.

The designation "U.S. Cl." appearing in this section refers to the U.S. class in effect prior to Sep. 1, 1973 rather than the international class which applies to applications filed on or after that date. For adoption of international classification see notice in the OFFICIAL GAZETTE of Jun. 26, 1973 (911 O.G. TM 210).

Application in more than one class

SN 76-699,950. NEILL CORPORATION, HAMMOND, LA.
FILED 10-19-2009.

SN 76-703,106. CANAL PIONEERS, LLC., COVINGTON, LA.
FILED 5-24-2010.

COOL & CARING



THE MARK CONSISTS OF STANDARD CHARACTERS WITHOUT CLAIM TO ANY PARTICULAR FONT, STYLE, SIZE, OR COLOR.

CLASS 35—ADVERTISING AND BUSINESS

FOR ARRANGING AND CONDUCTING MARKETING PROMOTIONAL EVENTS FOR OTHERS IN THE FIELD OF HAIR AND SKIN CARE PRODUCTS AND SERVICES; ARRANGING AND CONDUCTING BUSINESS CONFERENCES RELATING TO THE HAIR AND SKIN CARE SALON INDUSTRY; BUSINESS MANAGEMENT RELATING TO THE HAIR AND SKIN CARE SALON INDUSTRY (U.S. CLS. 100, 101 AND 102).

FIRST USE 4-1-2008; IN COMMERCE 4-1-2008.

CLASS 41—EDUCATION AND ENTERTAINMENT

FOR CONDUCTING EDUCATIONAL CONFERENCES IN THE FIELD OF HAIR AND SKIN CARE PRODUCTS AND SERVICES (U.S. CLS. 100, 101 AND 107).

FIRST USE 4-1-2008; IN COMMERCE 4-1-2008.
LAURA KOVALSKY, EXAMINING ATTORNEY

NO CLAIM IS MADE TO THE EXCLUSIVE RIGHT TO USE "BOWL" AND "BOWLING BAR", APART FROM THE MARK AS SHOWN.

THE NAME "SUGAR RAY" DOES NOT IDENTIFY A LIVING INDIVIDUAL.

THE MARK CONSISTS OF A STYLIZED DEPICTION OF A LONG, VERTICAL SIGN WITH A SINGLE LINE OUTLINE AROUND THE ENTIRE SIGN, WITH A TRUMPET AND A BOWLING BALL AT THE TOP ABOVE THE STYLIZED TERM "BOWL" THAT IS OFFSET ON BOTH SIDES BY FOUR STRAIGHT HORIZONTAL LINES, ABOVE THE STYLIZED TERM "SUGAR" DISPLAYED VERTICALLY WITH EACH LETTER ABOVE THE NEXT AND WITH A SINGLE DRUMSTICK ON EACH SIDE, ABOVE THE STYLIZED TERM "RAY'S" WHEREIN THE APOSTROPHE IS REPRESENTED BY AN EIGHTH NOTE AND THE WHOLE TERM IS ENCLOSED WITHIN A BOWED RECTANGULAR BAND, ABOVE THREE BOWED LINES ABOVE THE STYLIZED PHRASE "BON TEMPS" ABOVE THE STYLIZED PHRASE "BOWLING BAR".

THE ENGLISH TRANSLATION OF "BON TEMPS" IN THE MARK IS "GOOD TIMES".

CLASS 41—EDUCATION AND ENTERTAINMENT

FOR BOWLING ALLEYS (U.S. CLS. 100, 101 AND 107).

CLASS 43—HOTEL AND RESTAURANT SERVICES

FOR RESTAURANT SERVICES (U.S. CLS. 100 AND 101).
MYRIAH HABEEB, EXAMINING ATTORNEY

SN 76-704,562. STERILIZE-IT, LLC, UTICA, MI. FILED 9-20-2010.

THE MARK CONSISTS OF AN IMAGE OF VARIOUS STANDARD LETTER CHARACTERS AND A TEAR OR FLUID DROP SHAPE. THE STANDARD LETTER CHARACTERS FORM THE IMAGE "STERILIZE-IT". THE FLUID DROP IS LOCATED BELOW THE STANDARD LETTER CHARACTER "I" OF THE IMAGE PORTION "-IT".

CLASS 3—COSMETICS AND CLEANING PREPARATIONS

FOR ALL PURPOSE CLEANING PREPARATIONS; ALL-PURPOSE CLEANERS; CLEANING PREPARATIONS FOR HOUSEHOLD PURPOSES (U.S. CLS. 1, 4, 6, 50, 51 AND 52).

CLASS 5—PHARMACEUTICALS

FOR ALL PURPOSE STERILIZING AND DISINFECTING PREPARATIONS; HOUSEHOLD SANITIZING AND DISINFECTION PREPARATIONS (U.S. CLS. 6, 18, 44, 46, 51 AND 52).
SCOTT BIBB, EXAMINING ATTORNEY

SN 76-705,194. WEAN GREEN INC, CALGARY, ALBERTA, CANADA, FILED 11-1-2010.

THE MARK CONSISTS OF STANDARD CHARACTERS WITHOUT CLAIM TO ANY PARTICULAR FONT, STYLE, SIZE, OR COLOR.

PRIORITY CLAIMED UNDER SEC. 44(D) ON CANADA APPLICATION NO. 1,498,105, FILED 10-1-2010.

NO CLAIM IS MADE TO THE EXCLUSIVE RIGHT TO USE "GREEN", APART FROM THE MARK AS SHOWN.

CLASS 8—HAND TOOLS

FOR CUTLERY, NAMELY, FORKS AND SPOONS (U.S. CLS. 23, 28 AND 44).

CLASS 10—MEDICAL APPARATUS

FOR BABY BOTTLES (U.S. CLS. 26, 39 AND 44).

CLASS 12—VEHICLES

FOR HOUSEHOLD CONTAINERS FOR FOOD AND BEVERAGES (U.S. CLS. 19, 21, 23, 31, 35 AND 44).

CLASS 16—PAPER GOODS AND PRINTED MATTER

FOR COOKBOOKS (U.S. CLS. 2, 5, 22, 23, 29, 37, 38 AND 50).

CLASS 25—CLOTHING

FOR BABY CLOTHES, NAMELY, TOPS, BOTTOMS, BODYSUITS (U.S. CLS. 22 AND 39).
ERNEST SHOSHO, EXAMINING ATTORNEY

SN 76-705,861. BIG EASY, L.L.C., BROOKLYN, NY. FILED 1-3-2011.

THE MARK CONSISTS OF STANDARD CHARACTERS WITHOUT CLAIM TO ANY PARTICULAR FONT, STYLE, SIZE, OR COLOR.

CLASS 9—ELECTRICAL AND SCIENTIFIC APPARATUS

FOR LENSES FOR CAMERAS, CAMERA FILTERS, CAMERA CASES, TRIPODS, BATTERY CHARGERS, FLASH UNITS, NAMELY, FLASH LAMPS; CARD READERS, NAMELY, FLASH CARD READERS; CAMERA CABLES, NAMELY, ELECTRONIC CABLES; VIDEO LIGHTS FOR USE ON VIDEO CAMERAS, AND BRACKETS, NAMELY, CAMERA FLASHBRACKETS (U.S. CLS. 21, 23, 26, 36 AND 38).

CLASS 21—HOUSEWARES AND GLASS

FOR CAMERA LENS CLEANING KITS COMPRISED OF A BRUSH AND ALSO INCLUDING WIPES AND A LIQUID SOLUTION; AND CLEANING CLOTHS FOR CAMERA LENSES (U.S. CLS. 2, 13, 23, 29, 30, 33, 40 AND 50).

MARLENE BELL, EXAMINING ATTORNEY

SN 76-706,080. PENNSYLVANIA DEPT. OF CONSERVATION & NATURAL RESOURCES, HARRISBURG, PA. FILED 1-21-2011.

THE MARK CONSISTS OF STANDARD CHARACTERS WITHOUT CLAIM TO ANY PARTICULAR FONT, STYLE, SIZE, OR COLOR.

CLASS 35—ADVERTISING AND BUSINESS

FOR PROMOTING PUBLIC AWARENESS OF THE NEED FOR TREES AND THE NEED TO RESTORE TREE COVER AS AN IMPORTANT FEATURE OF INFRASTRUCTURE FOR COMMUNITIES; PROMOTING PUBLIC AWARENESS OF THE NEED FOR TREES BY SOLICITING VOLUNTEERS TO PLANT AND CARE FOR TREES (U.S. CLS. 100, 101 AND 102).

FIRST USE 4-0-2004; IN COMMERCE 4-0-2004.

CLASS 41—EDUCATION AND ENTERTAINMENT

FOR EDUCATIONAL SERVICES AND TRAINING, NAMELY, PROVIDING COMMUNITY WORKSHOPS 1) IN THE FIELD OF THE BENEFIT OF TREES AND THE NEED TO RESTORE TREE COVER AS AN IMPORTANT FEATURE OF INFRASTRUCTURE FOR COMMUNITIES AND 2) IN THE FIELD OF TREE PLANTING (U.S. CLS. 100, 101 AND 107).

FIRST USE 4-0-2004; IN COMMERCE 4-0-2004.
ELI HELLMAN, EXAMINING ATTORNEY

CLASS 28—TOYS AND SPORTING GOODS

FOR ANIMAL HUNTING DECOYS; CAMOUFLAGE NETTING USED IN HUNTING; CAMOUFLAGE TAPE USED IN HUNTING; CAMOUFLAGE SCREENS USED IN HUNTING; HUNTING EQUIPMENT, NAMELY, HUNTING BOWS; HUNTING ATTRACTANTS; HUNTING GAME CALLS; LURES FOR HUNTING; HUNTING STANDS; HUNTING BLINDS; HUNTING CAMOUFLAGE USED AS HUNTING BLINDS; HUNTING DECOY BAGS; SCENT ELIMINATING SPRAYS OR POWDERS OR WIPES ASSOCIATED WITH HUNTING AND OUTDOOR ACTIVITY; TREESTANDS FOR HUNTING; ANIMAL OR FOWL HUNTING DECOYS (U.S. CLS. 22, 23, 38 AND 50).

JAMES MACFARLANE, EXAMINING ATTORNEY

SN 76-706,814. SHALOM INTERNATIONAL, INC., NEW YORK, NY. FILED 3-15-2011.

TORQUE CITY

THE MARK CONSISTS OF STANDARD CHARACTERS WITHOUT CLAIM TO ANY PARTICULAR FONT, STYLE, SIZE, OR COLOR.

CLASS 14—JEWELRY

FOR MEN'S JEWELRY (U.S. CLS. 2, 27, 28 AND 50).

CLASS 25—CLOTHING

FOR BELTS AND SCARVES (U.S. CLS. 22 AND 39).
JOHN SCHUYLER YARD, EXAMINING ATTORNEY

SN 76-707,230. CYBER KIDZ INTERNATIONAL, INC., PISCATAWAY, NJ. FILED 4-12-2011.

TASTE

THE MARK CONSISTS OF STANDARD CHARACTERS WITHOUT CLAIM TO ANY PARTICULAR FONT, STYLE, SIZE, OR COLOR.

CLASS 16—PAPER GOODS AND PRINTED MATTER

FOR PENS, PENCILS, SHARPENERS, AND ERASERS (U.S. CLS. 2, 5, 22, 23, 29, 37, 38 AND 50).

CLASS 28—TOYS AND SPORTING GOODS

FOR BUBBLE SOLUTION AND TOY DEVICE FOR BLOWING BUBBLES (U.S. CLS. 22, 23, 38 AND 50).
SHANNON TWOHIG, EXAMINING ATTORNEY

SN 76-707,178. ALLEN, MARSHALL STUART, GULFPORT, MS. FILED 4-8-2011.



THE MARK CONSISTS OF THE WORDING "DEERY WOODS" IN A STYLIZED FONT ACROSS A DEER'S HEAD WITH ANTLERS.

CLASS 25—CLOTHING

FOR CLOTHING, NAMELY, SHIRTS, PANTS, COATS, CAPS, HATS, FOUL WEATHER GEAR, GLOVES, JACKETS, SHORTS, SWEATERS, TEE SHIRTS, VESTS, BELTS, BLOUSES, HEAD NETS, NETTED FACE VEILS, COVERALLS, OVERALLS, JEANS, CAMOUFLAGE BOOTS, HUNTING JACKETS, AND BOOTS (U.S. CLS. 22 AND 39).

SN 77-015,467. NATIONAL SECURITY SOLUTIONS, CROFTON, MD. FILED 10-6-2006.

Connecting The Dots

THE MARK CONSISTS OF STANDARD CHARACTERS WITHOUT CLAIM TO ANY PARTICULAR FONT, STYLE, SIZE, OR COLOR.

CLASS 42—SCIENTIFIC AND COMPUTER SERVICES

FOR RESEARCH IN THE FIELD OF INTELLIGENCE AND SECURITY (U.S. CLS. 100 AND 101).
FIRST USE 5-1-2006; IN COMMERCE 7-15-2006.

CLASS 45—PERSONAL AND LEGAL SERVICES

FOR BACKGROUND INVESTIGATION AND RESEARCH SERVICES; MONITORING SECURITY SYSTEMS; PERSONAL SECURITY CONSULTATION; PROVIDING INTELLIGENCE AND INFORMATION TO LOCAL, STATE AND FEDERAL LAW ENFORCEMENT AGENCIES RELATING TO ORGANIZED CRIME NETWORKS THAT OPERATE ACROSS JURISDICTIONAL LINES; SECURITY GUARD SERVICES; SECURITY INSPECTION SERVICES FOR OTHERS (U.S. CLS. 100 AND 101).

FIRST USE 5-1-2006; IN COMMERCE 7-15-2006.
CARYN GLASSER, EXAMINING ATTORNEY

SN 77-067,773. EXPLOSION SPORTS TRAINING, LLC, FRANKLIN, TN. FILED 12-19-2006.

D1

THE MARK CONSISTS OF STANDARD CHARACTERS WITHOUT CLAIM TO ANY PARTICULAR FONT, STYLE, SIZE, OR COLOR.

OWNER OF U.S. REG. NO. 2,877,559.

CLASS 35—ADVERTISING AND BUSINESS

FOR MANAGEMENT OF WELLNESS CENTERS FOR OTHERS (U.S. CLS. 100, 101 AND 102).
FIRST USE 2-1-2002; IN COMMERCE 3-1-2003.

SN 77-067,168. EXPLOSION SPORTS TRAINING, LLC, FRANKLIN, TN. FILED 12-19-2006.

CLASS 44—MEDICAL, BEAUTY AND AGRICULTURAL SERVICES

FOR PHYSICAL THERAPY (U.S. CLS. 100 AND 101).
FIRST USE 2-1-2002; IN COMMERCE 3-1-2003.
ROBIN MITTLER, EXAMINING ATTORNEY



SN 77-143,869. HUDSON, CHARLES F.JR., OCALA, FL. FILED 3-29-2007.

OWNER OF U.S. REG. NO. 2,877,559.
THE COLOR(S) GREY, RED, AND WHITE IS/ARE CLAIMED AS A FEATURE OF THE MARK.

THE MARK CONSISTS OF A RED SQUARE WITH ROUNDED EDGES AND A GREY BORDER. THE SQUARE CONTAINS THE LETTER "D" AND AN UNDERLINED NUMBER "1" IN WHITE.

CLASS 35—ADVERTISING AND BUSINESS

FOR MANAGEMENT OF WELLNESS CENTERS FOR OTHERS (U.S. CLS. 100, 101 AND 102).
FIRST USE 2-1-2002; IN COMMERCE 3-1-2003.

CLASS 41—EDUCATION AND ENTERTAINMENT

FOR SPORTS TRAINING (U.S. CLS. 100, 101 AND 107).
FIRST USE 2-1-2002; IN COMMERCE 2-1-2002.

CLASS 44—MEDICAL, BEAUTY AND AGRICULTURAL SERVICES

FOR PHYSICAL THERAPY (U.S. CLS. 100 AND 101).
FIRST USE 2-1-2002; IN COMMERCE 3-1-2003.
ROBIN MITTLER, EXAMINING ATTORNEY

THE MARK CONSISTS OF STANDARD CHARACTERS WITHOUT CLAIM TO ANY PARTICULAR FONT, STYLE, SIZE, OR COLOR.

CLASS 5—PHARMACEUTICALS

FOR INSECTICIDES FOR USE IN EQUINE AND BOVINE ENVIRONMENTS (U.S. CLS. 6, 18, 44, 46, 51 AND 52).
FIRST USE 10-8-1982; IN COMMERCE 10-8-1982.

CLASS 7—MACHINERY

FOR INSECTICIDE DISPENSING SYSTEMS, NAMELY, POWER-OPERATED SPRAYERS FOR INSECTICIDE FOR USE IN ANIMAL ENVIRONMENTS, NAMELY, EQUINE AND BOVINE (U.S. CLS. 13, 19, 21, 23, 31, 34 AND 35).
FIRST USE 10-8-1982; IN COMMERCE 10-8-1982.
DAVID I, EXAMINING ATTORNEY

SHOO-FLY

SN 77-144,541. HUDSON JR., CHARLES F., OCALA, FL.
FILED 3-30-2007.



THE MARK CONSISTS OF STYLIZED LETTERING OF THE WORD "SHOO-FLY" WITH A LOGO COMPRISED OF A SIMULATED LENGTH OF TUBING EXTENDING FROM THE LETTER "S" TERMINATING IN A SIMULATED NOZZLE DISPENSING A MIST OVER AN INVERTED FLY IN FRONT OF A TOMBSTONE.

CLASS 5—PHARMACEUTICALS

FOR INSECTICIDES FOR USE IN EQUINE AND BOVINE ENVIRONMENTS (U.S. CLS. 6, 18, 44, 46, 51 AND 52).

FIRST USE 10-8-1982; IN COMMERCE 10-8-1982.

CLASS 7—MACHINERY

FOR INSECTICIDE DISPENSING SYSTEMS, NAMELY, POWER-OPERATED SPRAYERS FOR INSECTICIDE FOR USE IN ANIMAL ENVIRONMENTS, NAMELY, EQUINE AND BOVINE (U.S. CLS. 13, 19, 21, 23, 31, 34 AND 35).

FIRST USE 10-8-1982; IN COMMERCE 10-8-1982.
MARK SPARACINO, EXAMINING ATTORNEY

SN 77-192,138. BOLD BEAN COFFEE ROASTERS, LLC,
JACKSONVILLE, FL. FILED 5-29-2007.



NO CLAIM IS MADE TO THE EXCLUSIVE RIGHT TO USE "BOLD BEAN" AND "COFFEE ROASTERS", APART FROM THE MARK AS SHOWN.

THE COLOR(S) RED, BLACK AND WHITE IS/ARE CLAIMED AS A FEATURE OF THE MARK.

THE MARK CONSISTS OF A RED EXCLAMATION POINT WITH A BLACK AND WHITE COFFEE BEAN IN THE CENTER OF THE PERIOD OF THE EXCLAMATION POINT. THE RED EXCLAMATION POINT BISECTS THE WORDS "BOLD" AND "BEAN"(IN BLACK) AND ALSO THE WORDS "COFFEE" AND "ROASTERS"(IN BLACK). A RED LINE UNDERSCORES "BOLD BEAN" WITH THE WORDS "COFFEE ROASTERS" BENEATH THE RED LINE.

CLASS 30—STAPLE FOODS

FOR BEVERAGES MADE OF COFFEE; COFFEE; COFFEE BEANS; GROUND COFFEE BEANS; PREPARED COFFEE AND COFFEE-BASED BEVERAGES; ROASTED COFFEE BEANS (U.S. CL. 46).

CLASS 40—MATERIAL TREATMENT

FOR COFFEE ROASTING AND PROCESSING (U.S. CLS. 100, 103 AND 106).

CLASS 43—HOTEL AND RESTAURANT SERVICES

FOR COFFEE-HOUSE AND SNACK-BAR SERVICES (U.S. CLS. 100 AND 101).

MARILYN IZZI, EXAMINING ATTORNEY

SN 77-229,952. UFO VIDEO, INC., VENICE, CA. FILED 7-15-2007.

UFOTV

THE MARK CONSISTS OF STANDARD CHARACTERS WITHOUT CLAIM TO ANY PARTICULAR FONT, STYLE, SIZE, OR COLOR.
SEC. 2(F).

CLASS 9—ELECTRICAL AND SCIENTIFIC APPARATUS

FOR DIGITAL MEDIA, NAMELY, CDS, DVDS, DOWNLOADABLE FILES FEATURING UFOS AND SCIENCE; PRE-RECORDED CDS, VIDEO TAPES, LASER DISKS AND DVDS FEATURING UFOS AND SCIENCE; DOWNLOADABLE MP3 FILES, MP3 RECORDINGS, ONLINE DISCUSSION BOARDS, WEB CASTS, POD CASTS FEATURING MUSIC, AUDIO BOOKS AND NEWS BROADCASTS; DOWNLOADABLE FILMS AND TV PROGRAMS FEATURING UFOS AND SCIENCE PROVIDED VIA A VIDEO-ON-DEMAND SERVICE; MOTION PICTURE FILMS ABOUT UFOS AND SCIENCE; DVDS FEATURING UFOS AND SCIENCE; ELECTRONIC PUBLICATIONS, NAMELY, BOOKS AND MAGAZINES FEATURING UFOS AND SCIENCE RECORDED ON COMPUTER MEDIA (U.S. CLS. 21, 23, 26, 36 AND 38).

FIRST USE 1-1-2001; IN COMMERCE 1-1-2001.

CLASS 38—COMMUNICATION

FOR INTERNET BROADCASTING SERVICES (U.S. CLS. 100, 101 AND 104).

FIRST USE 1-1-2001; IN COMMERCE 1-1-2001.

CLASS 41—EDUCATION AND ENTERTAINMENT

FOR ELECTRONIC PUBLISHING SERVICES, NAMELY, PUBLICATION OF TEXT AND GRAPHIC WORKS OF OTHERS ON CD, DVD, ON-LINE FEATURING UFO AND SCIENCE; PRODUCTION OF DVDS, VIDEOTAPES AND TELEVISION PROGRAMS FEATURING UFOS AND SCIENCE; ENTERTAINMENT, NAMELY, A CONTINUING UFO AND SCIENCE SHOW BROADCAST OVER TELEVISION, SATELLITE, AUDIO, AND VIDEO MEDIA; NEWS SYNDICATION FOR THE BROADCASTING INDUSTRY; FILM STUDIOS; PRODUCTION AND DISTRIBUTION OF TELEVISION SHOWS AND MOVIES (U.S. CLS. 100, 101 AND 107).

FIRST USE 1-1-2001; IN COMMERCE 1-1-2001.
JENNY PARK, EXAMINING ATTORNEY

SN 77-234,953. PHILADELPHIA HEALTH & EDUCATION CORPORATION, DBA DREXEL UNIVERSITY COLLEGE OF MEDICINE, PHILADELPHIA, PA. FILED 7-20-2007.

GEM

THE MARK CONSISTS OF STANDARD CHARACTERS WITHOUT CLAIM TO ANY PARTICULAR FONT, STYLE, SIZE, OR COLOR.

CLASS 41—EDUCATION AND ENTERTAINMENT

FOR (BASED ON INTENT TO USE) EDUCATION PROGRAM IN MEDICINE AND HEALTHCARE RELATED TO GENDER AND ETHNICITY (U.S. CLS. 100, 101 AND 107).

CLASS 42—SCIENTIFIC AND COMPUTER SERVICES

FOR (BASED ON INTENT TO USE) MEDICAL RESEARCH (U.S. CLS. 100 AND 101).

CLASS 44—MEDICAL, BEAUTY AND AGRICULTURAL SERVICES

FOR (BASED ON USE IN COMMERCE) MEDICAL SERVICES (U.S. CLS. 100 AND 101).
FIRST USE 2-0-2006; IN COMMERCE 2-0-2006.
TINA BROWN, EXAMINING ATTORNEY

SN 77-291,275. WINPAK LTD., WINNIPEG, MANITOBA, CANADA, FILED 9-28-2007.

WINCARE

THE MARK CONSISTS OF STANDARD CHARACTERS WITHOUT CLAIM TO ANY PARTICULAR FONT, STYLE, SIZE, OR COLOR.

PRIORITY CLAIMED UNDER SEC. 44(D) ON CANADA APPLICATION NO. 1364682, FILED 9-24-2007, REG. NO. TMA780485, DATED 10-25-2010, EXPIRES 10-25-2025.

CLASS 6—METAL GOODS

FOR FLEXIBLE PACKAGING MATERIALS FOR THE HEALTHCARE INDUSTRY, NAMELY, ALUMINUM FOIL LIDDING TO SEAL PRE-FORMED BLISTER PACKS (U.S. CLS. 2, 12, 13, 14, 23, 25 AND 50).

CLASS 17—RUBBER GOODS

FOR LAMINATED PLASTIC FILMS AND LAYERS OF PLASTIC LAMINATED OR GLUED TOGETHER IN ROLLSTOCK FORM FOR USE IN THE MANUFACTURE OF POUCH PACKAGING (U.S. CLS. 1, 5, 12, 13, 35 AND 50).
MICHAEL KEATING, EXAMINING ATTORNEY

SN 77-291,981. TRUSSARDI S.P.A., 20122 MILANO, ITALY, FILED 9-28-2007.



OWNER OF ITALY REG. NO. 790992, DATED 9-27-1999, RENEWED AS REG. NO. 1275328, DATED 4-22-2010, EXPIRES 5-30-2017.

OWNER OF ITALY REG. NO. 727957, DATED 10-13-1997, RENEWED AS REG. NO. 1135144, DATED 9-3-2008, EXPIRES 6-21-2015.

OWNER OF U.S. REG. NOS. 1,397,598, 3,340,122 AND OTHERS.

CLASS 20—FURNITURE AND ARTICLES NOT OTHERWISE CLASSIFIED

FOR FURNITURE, NAMELY, BEDS, TABLES, STOOLS, CHAIRS, ARM CHAIRS, FOLDING PARTITION SCREENS, COUCHES, COCKTAIL CABINETS, BOOKSHELVES, BOOKCASES, WRITING TABLES, DESKS, SIDEBARDS, SERVING TROLLEYS, CLOTHES TREES IN THE NATURE OF COAT RACKS AND NON-ELECTRIC CLOTHES RACKS FOR HANGING CLOTHES, HALL TABLES, CUPBOARDS, MIRRORS, PICTURE FRAMES, AND SMALL ORNAMENTAL FIGURINES OF WOOD, CORK, CANE, REEDS, WICKER, BONE, WHALEBONE, IVORY, HORN, SHELL, AMBER, MOTHER-OF-PEARL, MEERSCHAUM, CELLULOID AND SYNTHETIC RESINS (U.S. CLS. 2, 13, 22, 25, 32 AND 50).

CLASS 22—CORDAGE AND FIBERS

FOR ROPES, STRING, TENTS, TARPAULINS, SAILS, BAGS FOR THE TRANSPORTATION OR STORAGE OF MATERIALS IN BULK; HORTICULTURAL BAGS AND SACKS, NAMELY BAGS AND SACKS MADE OF WOVEN SYNTHETIC OR NATURAL FIBERS OR PLASTICS MATERIALS, ALL FOR USE IN GROWING ANY TYPE OF PLANT, SHRUB OR TREE, MAIL SACKS, NAMELY, FUNCTIONAL SACKS FOR RECEIVING AND HOLDING INCOMING MAIL PUT THROUGH A DOOR MAIL SLOT, SACKS OR BAGS FOR THE TRANSPORTATION OR STORAGE OF MATERIALS IN BULK FOR PACKAGING AND FOR STORING GOODS, COTTON-WOOL PADDING AND WADDING AND PADDING MATERIALS FOR FURNITURE, FIBROUS RAW MATERIAL FOR WEAVING (U.S. CLS. 1, 2, 7, 19, 22, 42 AND 50).

CLASS 23—YARNS AND THREADS

FOR YARNS AND THREADS (U.S. CL. 43).

CLASS 24—FABRICS

FOR FABRICS FOR THE MANUFACTURE OF CLOTHING, UPHOLSTERY FABRICS, FOULARDS, HANDKERCHIEFS, AND BUTTERFLY NETS (U.S. CLS. 42 AND 50).

CLASS 26—FANCY GOODS

FOR LACES, EMBROIDERY, RIBBONS, BUTTONS, PRESS BUTTONS, ARTIFICIAL FLOWERS (U.S. CLS. 37, 39, 40, 42 AND 50).

CLASS 27—FLOOR COVERINGS

FOR CARPETS, DOORMATS; PLASTIC, RUBBER, CORK AND NON-METALLIC MATS, LINOLEUM AND MOQUETTE PLASTICS TO COVER FLOORS (U.S. CLS. 19, 20, 37, 42 AND 50).
THOMAS MANOR, EXAMINING ATTORNEY

SN 77-360,817. TOTALLY MANAGEMENT LTD., DBA BLD, LONDON, UNITED KINGDOM, FILED 12-28-2007.

SN 77-360,819. TOTALLY MANAGEMENT LTD., DBA BLD, LONDON, UNITED KINGDOM, FILED 12-28-2007.



THE MARK CONSISTS OF THE LETTERS "BLD" WITH SEVERAL SILHOUETTES.

CLASS 16—PAPER GOODS AND PRINTED MATTER

FOR PAPER, CARDBOARD AND GOODS MADE FROM THESE MATERIALS RELATED TO THE LEGAL PROFESSION, NAMELY, BOOKS, PAMPHLETS, HAND-OUTS, WORKBOOKS, WRITING TABLETS, AND BOOK BINDING MATERIAL; PHOTOGRAPHS; STATIONERY; ADHESIVES FOR STATIONERY OR HOUSEHOLD PURPOSES; ARTISTS' MATERIALS, NAMELY, PENCILS, PENS, PRINTED INSTRUCTIONAL, EDUCATIONAL AND TEACHING MATERIALS, NOT INCLUDING EDUCATIONAL APPARATUS, IN THE FIELD OF LAW; PLASTIC MATERIALS FOR PACKAGING, NAMELY, PLASTIC BAGS, PLASTIC BUBBLE PACKS, PLASTIC WRAP; PRINTED BOOKS IN THE FIELD OF LAW OR LEGAL OR JUDICIAL RECRUITING; DIRECTORIES OF LEGAL PROFESSIONALS AND ORGANIZATIONS (U.S. CLS. 2, 5, 22, 23, 29, 37, 38 AND 50).

CLASS 35—ADVERTISING AND BUSINESS

FOR ADVERTISING AND ADVERTISEMENT SERVICES; ADVERTISING AND COMMERCIAL INFORMATION SERVICES, VIA THE INTERNET; BUSINESS MANAGEMENT AND ADMINISTRATION CONSULTANCY; BUSINESS MANAGEMENT; BUSINESS ADMINISTRATION CONSULTANCY; RECRUITMENT ADVERTISEMENT SERVICES, NAMELY, PROVIDING ON-LINE AVAILABLE EMPLOYMENT INFORMATION IN THE LEGAL AND JUDICIAL FIELDS; POSTING OF OPPORTUNITIES RELATING TO THE LEGAL FIELD, NAMELY, PERSONNEL PLACEMENT AND RECRUITMENT; EMPLOYMENT COUNSELING IN THE LEGAL FIELD; CAREER NETWORKING SERVICES; HUMAN RESOURCES CONSULTATION; ON-LINE BUSINESS DIRECTORIES FEATURING LEGAL PROFESSIONALS; ATTORNEY REFERRALS; PROVIDING AN INTERNET WEBSITE FEATURING INFORMATION IN THE FIELDS OF LAW, LEGAL AND JUDICIAL EMPLOYMENT RECRUITING, PROFESSIONAL NETWORKING IN THE LEGAL FIELD, CAREER PLACEMENT AND CAREER ADVANCEMENT FOR LEGAL PROFESSIONALS AND LAW STUDENTS (U.S. CLS. 100, 101 AND 102).

CLASS 41—EDUCATION AND ENTERTAINMENT

FOR EDUCATIONAL SERVICES, NAMELY, TRAINING SERVICES IN THE FIELD OF LAW, TRAINING SERVICES IN THE FIELD OF LEGAL CAREER PLANNING, TRAINING IN THE FIELD OF LEGAL PLACEMENT AND ADVANCEMENT, EDUCATING STUDENTS BY PROVIDING COURSES OF INSTRUCTION IN THE FIELD OF LEGAL PROFESSION AT THE PRIMARY, SECONDARY, COLLEGIATE, AND POST-COLLEGIATE LEVELS (U.S. CLS. 100, 101 AND 107).

CLASS 45—PERSONAL AND LEGAL SERVICES

FOR PROVIDING INFORMATION IN THE FIELD OF LAW VIA THE INTERNET (U.S. CLS. 100 AND 101).
KATHRYN COWARD, EXAMINING ATTORNEY

BLD

THE MARK CONSISTS OF STANDARD CHARACTERS WITHOUT CLAIM TO ANY PARTICULAR FONT, STYLE, SIZE, OR COLOR.

CLASS 16—PAPER GOODS AND PRINTED MATTER

FOR PAPER, CARDBOARD AND GOODS MADE FROM THESE MATERIALS RELATED TO THE LEGAL PROFESSION, NAMELY, BOOKS, PAMPHLETS, HAND-OUTS, WORKBOOKS, WRITING TABLETS, AND BOOK BINDING MATERIAL; PHOTOGRAPHS; STATIONERY; ADHESIVES FOR STATIONERY OR HOUSEHOLD PURPOSES; ARTISTS' MATERIALS, NAMELY, PENCILS, PENS, PRINTED INSTRUCTIONAL, EDUCATIONAL AND TEACHING MATERIALS, NOT INCLUDING EDUCATIONAL APPARATUS, IN THE FIELD OF LAW; PLASTIC MATERIALS FOR PACKAGING, NAMELY, PLASTIC BAGS, PLASTIC BUBBLE PACKS, PLASTIC WRAP; PRINTED BOOKS IN THE FIELD OF LAW OR LEGAL OR JUDICIAL RECRUITING; DIRECTORIES OF LEGAL PROFESSIONALS AND ORGANIZATIONS (U.S. CLS. 2, 5, 22, 23, 29, 37, 38 AND 50).

CLASS 35—ADVERTISING AND BUSINESS

FOR ADVERTISING AND ADVERTISEMENT SERVICES; ADVERTISING AND COMMERCIAL INFORMATION SERVICES, VIA THE INTERNET; BUSINESS MANAGEMENT AND ADMINISTRATION CONSULTANCY; BUSINESS MANAGEMENT; BUSINESS ADMINISTRATION CONSULTANCY; RECRUITMENT ADVERTISEMENT SERVICES, NAMELY, PROVIDING ON-LINE AVAILABLE EMPLOYMENT INFORMATION IN THE LEGAL AND JUDICIAL FIELDS; POSTING OF OPPORTUNITIES RELATING TO THE LEGAL FIELD, NAMELY, PERSONNEL PLACEMENT AND RECRUITMENT; EMPLOYMENT COUNSELING IN THE LEGAL FIELD; CAREER NETWORKING SERVICES; HUMAN RESOURCES CONSULTATION; ON-LINE BUSINESS DIRECTORIES FEATURING LEGAL PROFESSIONALS; ATTORNEY REFERRALS; PROVIDING AN INTERNET WEBSITE FEATURING INFORMATION IN THE FIELDS OF LAW, LEGAL AND JUDICIAL EMPLOYMENT RECRUITING, PROFESSIONAL NETWORKING IN THE LEGAL FIELD, CAREER PLACEMENT AND CAREER ADVANCEMENT FOR LEGAL PROFESSIONALS AND LAW STUDENTS (U.S. CLS. 100, 101 AND 102).

CLASS 41—EDUCATION AND ENTERTAINMENT

FOR EDUCATIONAL SERVICES, NAMELY, TRAINING SERVICES IN THE FIELD OF LAW, TRAINING SERVICES IN THE FIELD OF LEGAL CAREER PLANNING, TRAINING IN THE FIELD OF LEGAL PLACEMENT AND ADVANCEMENT, EDUCATING STUDENTS BY PROVIDING COURSES OF INSTRUCTION IN THE FIELD OF LEGAL PROFESSION AT THE PRIMARY, SECONDARY, COLLEGIATE, AND POST-COLLEGIATE LEVELS (U.S. CLS. 100, 101 AND 107).

CLASS 45—PERSONAL AND LEGAL SERVICES

FOR PROVIDING INFORMATION IN THE FIELD OF LAW VIA THE INTERNET (U.S. CLS. 100 AND 101).
KATHRYN COWARD, EXAMINING ATTORNEY

SN 77-381,843. ADCOGROUP WORLD INC., SAINT-HUBERT, CANADA, FILED 1-28-2008.

IDEAJAB

THE MARK CONSISTS OF STANDARD CHARACTERS WITHOUT CLAIM TO ANY PARTICULAR FONT, STYLE, SIZE, OR COLOR.

PRIORITY CLAIMED UNDER SEC. 44(D) ON CANADA APPLICATION NO. 1376442, FILED 12-18-2007, REG. NO. TMA786,003, DATED 12-24-2010, EXPIRES 12-24-2025.

CLASS 6—METAL GOODS

FOR MODULAR DISPLAY SYSTEMS COMPRISED OF METAL POSTS; METAL WALL SUPPORTS IN THE NATURE OF MOUNTS FOR SPACE ARRANGEMENT, FOR MERCHANDISING GOODS, FOR HANGING FIXTURES; METAL HANGBARS FOR SUPPORTING MERCHANDISED, HANGING GOODS; PARTITIONS OF METAL FOR MODULAR DISPLAY SYSTEMS; METAL CAPS FOR POST, TUBING AND ROD ENDS FOR MODULAR DISPLAY SYSTEMS; METAL HOOKS FOR MODULAR DISPLAY SYSTEMS; METAL CLAMPS FOR ASSEMBLING METAL COMPONENTS AND FIXTURES; METAL PARTITION HOLDERS IN THE NATURE OF FASTENERS, NAMELY, METAL BARS AND CHAINS FOR MODULAR DISPLAY SYSTEMS; FASTENERS, NAMELY, METAL BARS FOR MODULAR DISPLAY SYSTEMS; METAL SHELVING FOR MODULAR DISPLAY SYSTEMS; METAL DISPLAY TABLES; DISPLAY COUNTERS (U.S. CLS. 2, 12, 13, 14, 23, 25 AND 50).

CLASS 20—FURNITURE AND ARTICLES NOT OTHERWISE CLASSIFIED

FOR MODULAR DISPLAY SYSTEMS COMPRISED OF NON-METAL SHELVING, NON-METAL FURNITURE PARTITIONS; METAL DISPLAY TABLES; DISPLAY COUNTERS (U.S. CLS. 2, 13, 22, 25, 32 AND 50).
CHRISTINA SOBRAL, EXAMINING ATTORNEY

SN 77-471,885. MACKA GIYIM SANAYI PAZARLAMA VE TICARET A.S., SISLI-ISTANBUL, TURKEY, FILED 5-12-2008.



OWNER OF TURKEY REG. NO. 200525619, DATED 6-22-2005, EXPIRES 6-22-2015.

THE MARK CONSISTS OF THE WORDING "MACHKA" AND A STYLIZED CAT'S FACE.

THE WORDING "MACHKA" HAS NO MEANING IN A FOREIGN LANGUAGE.

CLASS 14—JEWELRY

FOR JEWELRY MATERIALS, NAMELY, PLATINUM, SILVER; ARTIFICIAL JEWELRY MATERIALS, NAMELY, BEADS FOR USE IN THE MANUFACTURE OF JEWELRY, ARTIFICIAL GEMSTONES; GOLD, JEWELRY, PRECIOUS STONES; ORNAMENTS MADE OF PRECIOUS METAL; CUFF-LINKS, TIE-PINS; STATUES MADE OF PRECIOUS METAL; TRINKETS IN THE NATURE OF JEWELRY RINGS, CHARMS FOR JEWELRY; TROPHY CUPS GIVEN IN SPORT COMPETITIONS MADE OF PRECIOUS METAL; HOROLOGICAL AND CHRONOMETRIC INSTRUMENTS; CHRONOMETERS; WATCH CHAINS (U.S. CLS. 2, 27, 28 AND 50).

CLASS 18—LEATHER GOODS

FOR WORKED AND UNWORKED LEATHER, ANIMAL SKINS, IMITATIONS OF LEATHER, LININGS OF LEATHER FOR BOOTS AND SHOES, LEATHERS FOR LINING; GOODS FOR CARRYING PURPOSES MADE OF LEATHER, IMITATION LEATHER, OR OTHER NON-METAL MATERIALS, NAMELY, CARRY-ALL BAGS, LEATHER BOXES; LEATHER OR IMITATION LEATHER KEYHOLDERS; UMBRELLAS, PARASOLS, WALKING STICKS; WHIPS, HARNESS FITTINGS, SADDLES, STIRRUPS, SADDLE STRAPS (U.S. CLS. 1, 2, 3, 22 AND 41).

CLASS 25—CLOTHING

FOR UNDERCLOTHING, OUTER CLOTHING MADE OF ALL KINDS OF MATERIAL OTHER THAN PROTECTIVE PURPOSES, NAMELY, PANTS, SHIRTS, SKIRTS, DRESSES, JACKETS, COATS; SOCKS; FOOTWEAR; HEADGEAR, NAMELY, HATS, CAPS (U.S. CLS. 22 AND 39).

CLASS 35—ADVERTISING AND BUSINESS

FOR IMPORT AND EXPORT AGENCY SERVICES; COMMERCIAL AND INDUSTRIAL BUSINESS MANAGEMENT CONSULTATION; AUCTIONEERING SERVICES; OPERATING ON-LINE MARKETPLACES FOR SELLERS OF GOODS AND SERVICES; WHOLESALE AND RETAIL STORE SERVICES FEATURING UNDER CLOTHING, OUTER CLOTHING, SOCKS, FOOTWEAR, HEADWEAR; CATALOG ORDERING SERVICES FEATURING UNDER CLOTHING, OUTER CLOTHING, SOCKS, FOOTWEAR, HEADWEAR (U.S. CLS. 100, 101 AND 102).
TOBY BULLOFF, EXAMINING ATTORNEY

SN 77-496,184. SMOKE AND MIRRORS PRODUCTIONS LIMITED, LONDON, UNITED KINGDOM, FILED 6-11-2008.

SMOKE & MIRRORS

THE MARK CONSISTS OF STANDARD CHARACTERS WITHOUT CLAIM TO ANY PARTICULAR FONT, STYLE, SIZE, OR COLOR.

PRIORITY CLAIMED UNDER SEC. 44(D) ON ERPNCMNTY TM OFC APPLICATION NO. 006831821, FILED 4-15-2008, REG. NO. 006831821, DATED 5-14-2009, EXPIRES 4-15-2018.

CLASS 9—ELECTRICAL AND SCIENTIFIC APPARATUS

FOR EXPOSED PHOTOGRAPHIC FILMS (U.S. CLS. 21, 23, 26, 36 AND 38).

CLASS 41—EDUCATION AND ENTERTAINMENT

FOR PRODUCTION AND POST-PRODUCTION SERVICES IN THE NATURE OF COMPOSITING, EDITING AND ENCODING OF STILL IMAGES, TELEVISION, FILM AND VIDEO RECORDINGS; SPECIAL EFFECTS ANIMATION SERVICES FOR FILM AND VIDEO IN 2D AND 3D; POST-PRODUCTION EDITING SERVICES IN THE FIELD OF VIDEOS AND FILMS, NAMELY, FILM SCANNING AND COLOR GRADING (U.S. CLS. 100, 101 AND 107).

ANDREA BUTLER, EXAMINING ATTORNEY

CLASS 40—MATERIAL TREATMENT

FOR CUSTOM MANUFACTURE OF WORKBENCHES, RACKS, SHELVING, STORAGE CONTAINERS, NAMELY, DRAWERS, LOCKED BOXES, AND TRAYS, SECURITY SYSTEMS, CAGES, NAMELY, HOLDING PENS FOR ANIMALS OR HUMANS, AND ROLL OUT TRAYS FOR VEHICLES IN THE FIELDS OF INMATE AND PRISONER TRANSFER, CANINE TRANSFER, WEAPON STORAGE, BOMB DISPOSAL, EMERGENCY MEDICAL, EMERGENCY RESPONSE AND FIRE; CONSULTING SERVICES RELATING TO CUSTOM MANUFACTURE OF WORKBENCHES, RACKS, SHELVING, STORAGE CONTAINERS, NAMELY, DRAWERS, LOCKED BOXES, AND TRAYS, SECURITY SYSTEMS, CAGES, NAMELY, HOLDING PENS FOR ANIMALS OR HUMANS AND ROLL OUT TRAYS FOR VEHICLES IN THE FIELDS OF INMATE AND PRISONER TRANSFER, CANINE TRANSFER, WEAPON STORAGE, BOMB DISPOSAL, EMERGENCY MEDICAL, EMERGENCY RESPONSE AND FIRE; CUSTOM MANUFACTURE OF MODULAR WALK-IN VAN EQUIPMENT, NAMELY, WORKBENCHES, RACKS, SHELVING, AND STORAGE CONTAINERS FOR TOOLS, PARTS AND SUPPLIES (U.S. CLS. 100, 103 AND 106).

SN 77-517,658. OPS INC., KINGSTON, ONTARIO, CANADA, FILED 7-9-2008.

**OPS OPERATIONAL
PERFORMANCE SYSTEMS**

THE MARK CONSISTS OF STANDARD CHARACTERS WITHOUT CLAIM TO ANY PARTICULAR FONT, STYLE, SIZE, OR COLOR.

PRIORITY CLAIMED UNDER SEC. 44(D) ON CANADA APPLICATION NO. 1393395, FILED 4-29-2008, REG. NO. TMA764570, DATED 4-20-2010, EXPIRES 4-20-2025.

NO CLAIM IS MADE TO THE EXCLUSIVE RIGHT TO USE "OPERATIONAL PERFORMANCE SYSTEMS", APART FROM THE MARK AS SHOWN.

CLASS 12—VEHICLES

FOR RACKS, SHELVING, STORAGE CONTAINERS, NAMELY, DRAWERS, LOCK BOXES AND TRAYS, CAGES, NAMELY, HOLDING PENS FOR ANIMALS OR HUMANS, AND ROLL OUT TRAYS ALL SPECIFICALLY ADAPTED FOR VEHICLES IN THE FIELDS OF INMATE AND PRISONER TRANSFER, CANINE TRANSFER, WEAPON STORAGE, BOMB DISPOSAL, EMERGENCY MEDICAL, EMERGENCY RESPONSE AND FIRE; EQUIPMENT SPECIFICALLY ADAPTED FOR MODULAR WALK-IN VANS, STRAIGHT BODY TRUCKS AND TRAILERS, NAMELY, RACKS, SHELVING, AND STORAGE CONTAINERS FOR TOOLS, PARTS AND SUPPLIES (U.S. CLS. 19, 21, 23, 31, 35 AND 44).

CLASS 20—FURNITURE AND ARTICLES NOT OTHERWISE CLASSIFIED

FOR WORKBENCHES FOR VEHICLES IN THE FIELDS OF INMATE AND PRISONER TRANSFER, CANINE TRANSFER, WEAPON STORAGE, BOMB DISPOSAL, EMERGENCY MEDICAL, EMERGENCY RESPONSE AND FIRE (U.S. CLS. 2, 13, 22, 25, 32 AND 50).

CLASS 42—SCIENTIFIC AND COMPUTER SERVICES

FOR CUSTOM DESIGN OF WORKBENCHES, RACKS, SHELVING, STORAGE CONTAINERS, NAMELY, DRAWERS, LOCKED BOXES, AND TRAYS, SECURITY SYSTEMS, CAGES, NAMELY, HOLDING PENS FOR ANIMALS OR HUMANS, AND ROLL OUT TRAYS FOR VEHICLES IN THE FIELDS OF INMATE AND PRISONER TRANSFER, CANINE TRANSFER, WEAPON STORAGE, BOMB DISPOSAL, EMERGENCY MEDICAL, EMERGENCY RESPONSE AND FIRE; CONSULTING SERVICES RELATING TO CUSTOM DESIGN OF WORKBENCHES, RACKS, SHELVING, STORAGE CONTAINERS, NAMELY, DRAWERS, LOCKED BOXES, AND TRAYS, SECURITY SYSTEMS, CAGES, NAMELY, HOLDING PENS FOR ANIMALS OR HUMANS, AND ROLL OUT TRAYS FOR VEHICLES IN THE FIELDS OF INMATE AND PRISONER TRANSFER, CANINE TRANSFER, WEAPON STORAGE, BOMB DISPOSAL, EMERGENCY MEDICAL, EMERGENCY RESPONSE AND FIRE; CUSTOM DESIGN OF MODULAR WALK-IN VAN EQUIPMENT, NAMELY, WORKBENCHES, RACKS, SHELVING, AND STORAGE CONTAINERS FOR TOOLS, PARTS AND SUPPLIES (U.S. CLS. 100 AND 101).

ZACHARY BELLO, EXAMINING ATTORNEY

SN 77-521,239. FLORENTIN, DAVID GÉRARD, COGOLIN, FRANCE, FILED 7-14-2008.

FLORENTIN DESIGN

THE MARK CONSISTS OF STANDARD CHARACTERS WITHOUT CLAIM TO ANY PARTICULAR FONT, STYLE, SIZE, OR COLOR.

PRIORITY CLAIMED UNDER SEC. 44(D) ON FRANCE APPLICATION NO. 083564942, FILED 3-26-2008, REG. NO. 083564942, DATED 8-29-2008, EXPIRES 3-25-2018.

NO CLAIM IS MADE TO THE EXCLUSIVE RIGHT TO USE "DESIGN", APART FROM THE MARK AS SHOWN.

THE ENGLISH TRANSLATION OF "FLORENTIN" IN THE MARK IS "FLORENTINE".

CLASS 37—CONSTRUCTION AND REPAIR

FOR BUILDING CONSTRUCTION, MAINTENANCE, RENOVATION AND REPAIR SERVICES, IN PARTICULAR IN FLATS, REAL ESTATE PROPERTY, AND HOUSES; INSTALLATION OF INSULATION IN BUILDINGS AND BUILDING SEALING SERVICES; KITCHEN EQUIPMENT INSTALLATION; DEVELOPMENT OF REAL ESTATE; MASONRY; RUSTPROOFING; CONSULTANCY IN THE FIELD OF BUILDING CONSTRUCTION (U.S. CLS. 100, 103 AND 106).

CLASS 40—MATERIAL TREATMENT

FOR TREATMENT OF MATERIALS, NAMELY, COLOUR SEPARATION TREATMENT; CUSTOM ASSEMBLING OF MATERIALS FOR OTHERS; WOODWORKING, POTTERY FIRING, EMBROIDERY; WINDOW TINTING TREATMENT; METAL CASTING; LEATHER STAINING AND WORKING; FRAMING OF WORKS OF ART; MILLWORKING; ENGRAVING; COATING, NAMELY, ELECTROPLATING OF METALS; GOLD PLATING; TEXTILE TREATING IN THE NATURE OF MOTHPROOFING (U.S. CLS. 100, 103 AND 106).

CLASS 42—SCIENTIFIC AND COMPUTER SERVICES

FOR CONSTRUCTION DRAFTING; INTERIOR DECORATION SERVICES; INDUSTRIAL DESIGN; SURVEYING; GRAPHIC ARTS DESIGNING; MATERIAL TESTING; RESEARCH AND DEVELOPMENT OF NEW PRODUCTS FOR THIRD PARTIES, IN THE FIELD OF INTERIOR ARRANGEMENT AND ARCHITECTURE; STYLING IN THE NATURE OF INDUSTRIAL DESIGN; CIVIL ENGINEERING (U.S. CLS. 100 AND 101).
COLLEEN DOMBROW, EXAMINING ATTORNEY

CLASS 36—INSURANCE AND FINANCIAL

FOR PHARMACY BENEFIT MANAGEMENT SERVICES; INSURANCE ADMINISTRATION SERVICES; INSURANCE CLAIM ADMINISTRATION, PROCESSING, ADJUSTMENT, AND AUDITING SERVICES; ELECTRONIC PROCESSING OF INSURANCE CLAIMS AND PAYMENT DATA; ADMINISTRATION OF EMPLOYEE BENEFIT PLANS CONCERNING INSURANCE FOR OTHERS; MEDICAL INSURANCE CASE AND UTILIZATION REVIEW AND INSURANCE CLAIMS ADJUSTMENT SERVICES FOR HEALTHCARE PURCHASERS AND PAYORS AND PROVIDERS AND MEDICARE BENEFICIARIES; INSURANCE UNDERWRITING SERVICES FOR HEALTH INSURANCE; INSURANCE ACTUARIAL SERVICES; INSURANCE CARRIER, AGENCY, BROKERAGE, AND SUBROGATION SERVICES; FINANCIAL EVALUATION SERVICES FOR INSURANCE PURPOSES; INSURANCE INFORMATION AND CONSULTING SERVICES; INSURANCE CASE MANAGEMENT SERVICES, NAMELY, INSURANCE ELIGIBILITY REVIEW AND VERIFICATION OF MEDICAL SERVICES IN THE HEALTH INSURANCE INDUSTRY; MEDICAL INSURANCE CASE MANAGEMENT AND UTILIZATION REVIEW AND INSURANCE CLAIMS ADJUSTMENT SERVICES FOR HEALTHCARE PURCHASERS AND PAYORS AND PROVIDERS AND MEDICARE BENEFICIARIES; INSURANCE RISK MANAGEMENT SERVICES FOR OTHERS IN THE FIELD OF HEALTH CARE (U.S. CLS. 100, 101 AND 102).

CLASS 44—MEDICAL, BEAUTY AND AGRICULTURAL SERVICES

FOR MANAGED HEALTH CARE SERVICES (U.S. CLS. 100 AND 101).

CLASS 45—PERSONAL AND LEGAL SERVICES

FOR CASE MANAGEMENT SERVICES, NAMELY, COORDINATION OF MEDICAL SERVICES FOR HEALTH CARE PATIENTS BASED ON THEIR HEALTH INSURANCE (U.S. CLS. 100 AND 101).
MAYUR VAGHANI, EXAMINING ATTORNEY

SN 77-557,613. HEALTHSMART HOLDINGS INC., IRVING, TX. FILED 8-28-2008.

SN 77-557,615. HEALTHSMART HOLDINGS INC., IRVING, TX. FILED 8-28-2008.

HEALTHSMART



THE COLOR(S) BLUE AND GREEN IS/ARE CLAIMED AS A FEATURE OF THE MARK.

THE MARK CONSISTS OF THE BLUE WORD "HEALTH" AND THE GREEN WORD "SMART" TO THE RIGHT WITH A GREEN STYLIZED HUMAN FIGURE TO THE LEFT OF THE WORD "HEALTH" WHICH HAS ONE ARM USED AS THE HORIZONTAL LINE IN THE MIDDLE OF THE "H".

THE MARK CONSISTS OF STANDARD CHARACTERS WITHOUT CLAIM TO ANY PARTICULAR FONT, STYLE, SIZE, OR COLOR.

CLASS 35—ADVERTISING AND BUSINESS

FOR MANAGEMENT OF HEALTH CARE CLINICS AND MEDICAL PRACTICES FOR OTHERS; MEDICAL CLAIMS CASE MANAGEMENT SERVICES, NAMELY, ASSESSING HEALTH INSURANCE CLAIMS BASED ON THE MEDICAL SERVICES PROVIDED TO PATIENTS; BUSINESS MANAGEMENT AND CONSULTING SERVICES IN THE FIELD OF HEALTH CARE; MANAGEMENT OF INSURANCE AGENCIES AND BROKERS FOR OTHERS; BUSINESS RISK MANAGEMENT SERVICES FOR OTHERS IN THE FIELD OF HEALTH CARE; PROMOTING INSURANCE SERVICES FOR OTHERS; TRACKING AND MONITORING INSURANCE COMPLIANCE; DATA COMPILATION AND ANALYSIS IN THE FIELD OF INSURANCE (U.S. CLS. 100, 101 AND 102).

CLASS 35—ADVERTISING AND BUSINESS

FOR MANAGEMENT OF HEALTH CARE CLINICS AND MEDICAL PRACTICES FOR OTHERS; MEDICAL CLAIMS CASE MANAGEMENT SERVICES, NAMELY, ASSESSING HEALTH INSURANCE CLAIMS BASED ON THE MEDICAL SERVICES PROVIDED TO PATIENTS; BUSINESS MANAGEMENT AND CONSULTING SERVICES IN THE FIELD OF HEALTH CARE; MANAGEMENT OF INSURANCE AGENCIES AND BROKERS FOR OTHERS; BUSINESS RISK MANAGEMENT SERVICES FOR OTHERS IN THE FIELD OF HEALTH CARE; PROMOTING INSURANCE SERVICES FOR OTHERS; TRACKING AND MONITORING INSURANCE COMPLIANCE; DATA COMPILATION AND ANALYSIS IN THE FIELD OF INSURANCE (U.S. CLS. 100, 101 AND 102).

CLASS 36—INSURANCE AND FINANCIAL

FOR PHARMACY BENEFIT MANAGEMENT SERVICES; INSURANCE ADMINISTRATION SERVICES; INSURANCE CLAIM ADMINISTRATION, PROCESSING, ADJUSTMENT, AND AUDITING SERVICES; ELECTRONIC PROCESSING OF INSURANCE CLAIMS AND PAYMENT DATA; ADMINISTRATION OF EMPLOYEE BENEFIT PLANS CONCERNING INSURANCE FOR OTHERS; MEDICAL INSURANCE CASE AND UTILIZATION REVIEW AND INSURANCE CLAIMS ADJUSTMENT SERVICES FOR HEALTHCARE PURCHASERS AND PAYORS AND PROVIDERS AND MEDICARE BENEFICIARIES; INSURANCE UNDERWRITING SERVICES FOR HEALTH INSURANCE; INSURANCE ACTUARIAL SERVICES; INSURANCE CARRIER, AGENCY, BROKERAGE, AND SUBROGATION SERVICES; FINANCIAL EVALUATION SERVICES FOR INSURANCE PURPOSES; INSURANCE INFORMATION AND CONSULTING SERVICES; INSURANCE CASE MANAGEMENT SERVICES, NAMELY, INSURANCE ELIGIBILITY REVIEW AND VERIFICATION OF MEDICAL SERVICES IN THE HEALTH INSURANCE INDUSTRY; MEDICAL INSURANCE CASE MANAGEMENT AND UTILIZATION REVIEW AND INSURANCE CLAIMS ADJUSTMENT SERVICES FOR HEALTHCARE PURCHASERS AND PAYORS AND PROVIDERS AND MEDICARE BENEFICIARIES; INSURANCE RISK MANAGEMENT SERVICES FOR OTHERS IN THE FIELD OF HEALTH CARE (U.S. CLS. 100, 101 AND 102).

CLASS 44—MEDICAL, BEAUTY AND AGRICULTURAL SERVICES

FOR MANAGED HEALTH CARE SERVICES (U.S. CLS. 100 AND 101).

CLASS 45—PERSONAL AND LEGAL SERVICES

FOR CASE MANAGEMENT SERVICES, NAMELY, COORDINATION OF MEDICAL SERVICES FOR HEALTH CARE PATIENTS BASED ON THEIR HEALTH INSURANCE (U.S. CLS. 100 AND 101).

MAYUR VAGHANI, EXAMINING ATTORNEY

SN 77-566,882. RED DEVIL, INC., TULSA, OK. FILED 9-10-2008.

SPEED DEMON

THE MARK CONSISTS OF STANDARD CHARACTERS WITHOUT CLAIM TO ANY PARTICULAR FONT, STYLE, SIZE, OR COLOR.

OWNER OF U.S. REG. NOS. 854,145, 3,044,549 AND OTHERS.

CLASS 1—CHEMICALS

FOR CHEMICAL COMPOSITIONS IN THE NATURE OF STAIN REPELLANTS FOR USE IN THE GENERAL BUILDING AND CONSTRUCTION INDUSTRY (U.S. CLS. 1, 5, 6, 10, 26 AND 46).

FIRST USE 8-1-1967; IN COMMERCE 8-1-1967.

CLASS 4—LUBRICANTS AND FUELS

FOR SILICONE SPRAY LUBRICANT TO PREVENT STICKING OF DOORS AND WINDOWS, AND FEATURING A RUST AND CORROSION PREVENTATIVE FOR METAL SURFACES (U.S. CLS. 1, 6 AND 15).

FIRST USE 8-1-1967; IN COMMERCE 8-1-1967.

CLASS 7—MACHINERY

FOR POWER-OPERATED PAINT STIRRERS ATTACHABLE TO ELECTRIC DRILLS (U.S. CLS. 13, 19, 21, 23, 31, 34 AND 35).

FIRST USE 8-1-1967; IN COMMERCE 8-1-1967.

CLASS 16—PAPER GOODS AND PRINTED MATTER

FOR PAINT APPLICATORS (U.S. CLS. 2, 5, 22, 23, 29, 37, 38 AND 50).

FIRST USE 8-1-1967; IN COMMERCE 8-1-1967.

CLASS 17—RUBBER GOODS

FOR CAULKING COMPOUNDS; AND ANCHORING CEMENT FOR SETTING BOLTS, POSTS, HANDRAILS, SMALL EQUIPMENT, FENCES, COLUMNS AND NON-STRUCTURAL ANCHORS (U.S. CLS. 1, 5, 12, 13, 35 AND 50).

FIRST USE 8-1-1967; IN COMMERCE 8-1-1967.

FRANK LATTUCA, EXAMINING ATTORNEY

SN 77-569,029. SMARTDRIVE SYSTEMS, INC., SAN DIEGO, CA. FILED 9-12-2008.



OWNER OF U.S. REG. NOS. 3,819,803 AND 3,823,581.

THE MARK CONSISTS OF THE WORDING "SMARTDRIVE" TO THE RIGHT OF A SQUIGGLE DESIGN WITH THE APPEARANCE OF A DIVIDED ROADWAY.

CLASS 9—ELECTRICAL AND SCIENTIFIC APPARATUS

FOR VIDEO, AUDIO AND EVENT DIAGNOSTIC RECORDERS FOR USE IN VEHICLES; VIDEO, AUDIO AND EVENT RECORDERS FOR THE PURPOSE OF RECORDING, ANALYZING, SCORING OR TRENDING DRIVER BEHAVIOR AND INFORMATION; VIDEO, AUDIO AND EVENT RECORDERS FOR THE PURPOSE OF RECORDING, DOWNLOADING AND TRANSMITTING VEHICLE, DRIVING AND DRIVER INFORMATION (U.S. CLS. 21, 23, 26, 36 AND 38).

CLASS 35—ADVERTISING AND BUSINESS

FOR TRACKING, LOCATING AND MONITORING OF VEHICLES FOR COMMERCIAL PURPOSES; INFORMATION AND DATA COMPILING AND ANALYZING RELATING TO BUSINESS MANAGEMENT, SPECIFICALLY FOR THE REVIEW AND RATING OF RECORDED VIDEO, AUDIO AND EVENT INFORMATION CONCERNING VEHICLES, VEHICLE DRIVING BEHAVIOR AND DRIVER INFORMATION FOR FLEET MANAGERS, OWNERS AND VEHICLE MANUFACTURERS (U.S. CLS. 100, 101 AND 102).

CLASS 38—COMMUNICATION

FOR ON-LINE DELIVERY VIA A GLOBAL COMPUTER NETWORK OF RECORDED VIDEO, AUDIO AND EVENT INFORMATION CONCERNING VEHICLES, VEHICLE DRIVING BEHAVIOR AND DRIVER INFORMATION FOR FLEET MANAGERS, OWNERS AND VEHICLE MANUFACTURERS (U.S. CLS. 100, 101 AND 104).

ANDREA HACK, EXAMINING ATTORNEY

SN 77-632,004. CANADIAN FOOTBALL LEAGUE, TORONTO, CANADA, FILED 12-12-2008.

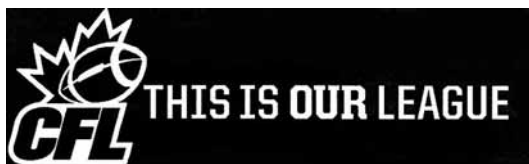

PRIORITY CLAIMED UNDER SEC. 44(D) ON CANADA APPLICATION NO. 1399591, FILED 6-13-2008, REG. NO. TMA799349, DATED 6-6-2011, EXPIRES 6-6-2026.

OWNER OF U.S. REG. NOS. 1,530,169, 3,576,258 AND OTHERS.

NO CLAIM IS MADE TO THE EXCLUSIVE RIGHT TO USE "LEAGUE", APART FROM THE MARK AS SHOWN.

THE MARK CONSISTS OF THE STYLIZED LETTERING "CFL" CROWNED WITH A FOOTBALL AND LEAF DESIGN FOLLOWED BY THE STYLIZED LETTERING "THIS IS OUR LEAGUE".

CLASS 16—PAPER GOODS AND PRINTED MATTER

FOR POSTERS, BALL POINT PENS, PENCILS, TRADING CARDS, PAPER FLAGS AND PENNANTS (U.S. CLS. 2, 5, 22, 23, 29, 37, 38 AND 50).

CLASS 20—FURNITURE AND ARTICLES NOT OTHERWISE CLASSIFIED

FOR PLASTIC BANNERS, SEAT CUSHIONS, PLASTIC KEY CHAINS (U.S. CLS. 2, 13, 22, 25, 32 AND 50).

CLASS 21—HOUSEWARES AND GLASS

FOR CUPS AND MUGS NOT OF PRECIOUS METAL, DRINKING GLASSES, BEER MUGS, DRINKING STEINS (U.S. CLS. 2, 13, 23, 29, 30, 33, 40 AND 50).

CLASS 24—FABRICS

FOR CLOTH FLAGS, CLOTH PENNANTS (U.S. CLS. 42 AND 50).

CLASS 25—CLOTHING

FOR FEMALE ADULT AND MALE ADULT APPAREL, NAMELY, T-SHIRTS, TANK TOPS, GOLF SHIRTS, FLEECE KNIT SWEATSHIRTS, POLO SHIRTS, VESTS; OUTERWEAR, NAMELY, VESTS, JERSEYS; REPLICAS AND AUTHENTIC JERSEYS; HEADWEAR, NAMELY, BANDANAS (U.S. CLS. 22 AND 39).

CLASS 28—TOYS AND SPORTING GOODS

FOR EMBOSSED FOOTBALLS, PARTY FAVORS IN THE NATURE OF CRACKERS AND NOISEMAKERS (U.S. CLS. 22, 23, 38 AND 50).

CLASS 41—EDUCATION AND ENTERTAINMENT

FOR ENTERTAINMENT SERVICES IN THE FORM OF TELEVISED PROFESSIONAL FOOTBALL EXHIBITIONS AND GAMES; EDUCATION AND ENTERTAINMENT SERVICES, NAMELY, ORGANIZATION OF SPORTS ACTIVITIES AND SPORTS EVENTS, NAMELY, FOOTBALL GAMES; ENTERTAINMENT SERVICES PROVIDED DURING INTERVALS AT SPORTS EVENTS, NAMELY, LIVE ENTERTAINMENT SHOWS FEATURING SCHOOL BANDS, CHEERLEADERS, SCHOOL FOOTBALL GAME DEMONSTRATIONS, ACROBATICS, GYMNASTICS, MUSICALS, PROFESSIONAL MUSICAL ACTS, DANCE TROUPES AND EXHIBITIONS DISPLAYING SPORTS PARAPHERNALIA; ARRANGING AND ORGANIZING OF COMPETITIONS, NAMELY, ARRANGING AND ORGANIZING OF FOOTBALL COMPETITIONS, PHYSICAL EDUCATION SERVICES; PRODUCTION OF RADIO AND TELEVISION PROGRAMS, LIVE SHOW PERFORMANCES AND DISPLAYS IN THE NATURE OF LIVE SPORTING EVENTS; ENTERTAINMENT SERVICES IN THE NATURE OF FOOTBALL GAME PROGRAMS BROADCAST VIA TELEVISION, CABLE, SATELLITE AND THE INTERNET (U.S. CLS. 100, 101 AND 107).

KATHLEEN M. VANSTON, EXAMINING ATTORNEY

SN 77-639,915. SOUTHERN CROSS DENTAL LABORATORIES PTY LTD, DOUBLE BAY, AUSTRALIA, FILED 12-24-2008.



OWNER OF AUSTRALIA REG. NO. 1279350, DATED 12-24-2008, EXPIRES 12-24-2018.

NO CLAIM IS MADE TO THE EXCLUSIVE RIGHT TO USE "DENTAL LABORATORIES", APART FROM THE MARK AS SHOWN.

THE COLOR(S) BLUE AND WHITE IS/ARE CLAIMED AS A FEATURE OF THE MARK.

THE MARK CONSISTS OF THE WORDING "SOUTHERN CROSS DENTAL LABORATORIES" IN THE COLOR WHITE, AND FIVE EIGHT-POINTED STARS IN THE COLOR WHITE, ALL ON A BLUE RECTANGLE-SHAPED BACKGROUND.

CLASS 10—MEDICAL APPARATUS

FOR APPARATUS FOR USE IN DENTISTRY AND ORTHODONTICS, NAMELY, REMOVABLE PROSTHODONTICS, NAMELY, METAL AND ACRYLIC BASED PARTIAL AND COMPLETE DENTURES, COBALT-CHROMIUM OR BIOCOMPATIBLE TITANIUM BILATERAL CASTINGS IN THE NATURE OF REPLACEMENT TEETH AND PRECISION RETAINED OVERDENTURES; FIXED AND REMOVABLE DENTAL IMPLANTS, NAMELY, FIXTURES, ABUTMENTS AND CROWNS; RESIN BONDED DENTAL BRIDGES, NAMELY, CANTILEVERED RESIN BONDED DENTAL BRIDGES; PRECISION ATTACHMENTS FOR DENTAL CROWN AND BRIDGEWORK, NAMELY, IMPLANTS AND REMOVABLE PROSTHESES, EXTRACORONAL, INTRACORONAL, LOCATORS, BALL ATTACHMENTS, ANCHORS AND BARS; OCCLUSAL SPLINTS, NAMELY, GELB SPLINTS, BRUXISM-MICHIGAN SPLINTS AND FARRAR SPLINTS; SPLINT ORTHODONTIC MYOFUNCTIONAL APPLIANCES, NAMELY, SOMAS; AND COMPOSITE DENTAL STENTS (U.S. CLS. 26, 39 AND 44).

CLASS 41—EDUCATION AND ENTERTAINMENT

FOR EDUCATION AND PROVIDING OF TRAINING, NAMELY, CONDUCTION OF CLASSES, SEMINARS, WORKSHOPS AND ONE-ON-ONE INSTRUCTION IN THE USE OF ORTHODONTIC AND DENTISTRY APPLIANCES; DENTAL EDUCATION TRAINING AND EVENTS, NAMELY, CONDUCTION OF CLASSES, SEMINARS AND WORKSHOPS IN THE FIELD OF DENTISTRY; ALL OF THE FOREGOING EXCLUDING HIGHER EDUCATION SERVICES THAT LEAD TO THE AWARD OF TERTIARY QUALIFICATIONS (U.S. CLS. 100, 101 AND 107).

CLASS 44—MEDICAL, BEAUTY AND AGRICULTURAL SERVICES

FOR MEDICAL SERVICES, NAMELY, THE PROVISION OF DENTAL AND ORAL CARE; ORTHODONTIC AND DENTISTRY SERVICES; ORTHODONTIC AND DENTAL TREATMENT; CONSULTING IN THE FIELD OF DENTISTRY AND ORTHODONTICS; PREVENTATIVE, COSMETIC AND IMPLANT DENTISTRY (U.S. CLS. 100 AND 101).

APRIL ROACH, EXAMINING ATTORNEY

CLASS 9—ELECTRICAL AND SCIENTIFIC APPARATUS

FOR REPLACEMENT PARTS FOR AUTOMOTIVE HEATING APPARATUS, NAMELY, ELECTRIC SWITCHES AND RELAYS; REPLACEMENT PARTS FOR AUTOMOTIVE AIR CONDITIONERS, NAMELY, ELECTRIC SWITCHES AND RELAYS; AUTOMOTIVE PARTS, NAMELY, OXYGEN SENSORS, EXHAUST GAS OXYGEN SENSORS, AIR FUEL SENSORS, AIR FUEL RATIO SENSORS, PLANAR SENSORS, WIDE BAND SENSORS, WIDE RANGE SENSORS, TITANIA SENSORS AND OXYGEN SENSORS FOR EMISSION REDUCTION FOR MOTORS AND ENGINES AND ELECTRONIC CONTROLS FOR MOTORS; COMPUTER CONTROL MODULES AND SENSING DEVICES UTILIZED FOR COMPUTER CONTROL OF THE PERFORMANCE OF INTERNAL COMBUSTION ENGINES; REPLACEMENT PARTS FOR LAND VEHICLES, NAMELY, REPROGRAMMED COMPUTERS FOR THE CONTROL OF THE ENGINE FUNCTIONS OF LAND VEHICLES; COMPUTER PERIPHERALS, NAMELY, COMPUTER CONTROL DEVICES IN THE NATURE OF ENGINE SENSOR ENGINE CONTROLS THAT PROVIDE INFORMATION TO ON-BOARD COMPUTERS; COMBINATION ANTENNA FOR USE IN THE RECEPTION OF AM AND FM SIGNALS AND FOR USE IN TRANSMITTING AND RECEIVING IN THE CITIZENS BAND FREQUENCIES; BATTERY CABLES, AUTOMOTIVE STARTER SWITCHES, VOLTAGE REGULATORS, AUTOMOTIVE RELAYS, AUTOMOTIVE RESISTANCE UNITS, NAMELY, ELECTRIC RESISTORS, AND ELECTRICAL VACUUM CONTROLS; ELECTRICAL COMPONENTS FOR THE CONTROL OF INTERNAL COMBUSTION ENGINES, NAMELY, VOLTAGE REGULATORS, AND MODULES FOR TRANSISTORIZED IGNITION SYSTEMS; ELECTRICAL PARTS FOR ENGINE DRIVEN LAND OR MARINE VEHICLES AND FARM AND INDUSTRIAL DEVICES UTILIZING INTERNAL COMBUSTION ENGINES, NAMELY, VOLTAGE REGULATORS, BATTERY CABLES, HEADLIGHT RELAYS, CUT-OUTS SWITCHES, DIMMER SWITCHES, HORN RELAYS, AUTOMOTIVE CABLES, AND ELECTRONIC IGNITION DISTRIBUTOR CONTROL DEVICES, NAMELY, VACUUM CONTROLS; REPAIR AND REPLACEMENT PARTS FOR AIR CONDITIONERS AND HEATERS FOR VEHICLES, NAMELY, COMBUSTION ENGINE LAND VEHICLE PARTS IN THE NATURE OF THERMOSTATS (U.S. CLS. 21, 23, 26, 36 AND 38).

FIRST USE 10-9-2007; IN COMMERCE 10-9-2007.

SN 77-639,949. STANDARD MOTOR PRODUCTS, INC., LONG ISLAND CITY, NY. FILED 12-24-2008.



NO CLAIM IS MADE TO THE EXCLUSIVE RIGHT TO USE "MOTOR PRODUCTS, INC", APART FROM THE MARK AS SHOWN.

THE MARK CONSISTS OF A PARTIAL GLOBE DESIGN, THE LETTERS "SMP", AND THE WORDS "STANDARD MOTOR PRODUCTS, INC".

CLASS 6—METAL GOODS

FOR MOTOR VEHICLE LOCKS ALL MADE OF METAL SOLD SEPARATELY FROM THE VEHICLE, NAMELY, MOTOR VEHICLE DOOR LOCKS, MOTOR VEHICLE TRUNK LOCKS, MOTOR VEHICLE IGNITION LOCKS, TRUCK BED COVER "T" HANDLE LOCKS, AND MOTOR VEHICLE GLOVE COMPARTMENT LOCKS; TENSION FASTENERS FOR ATTACHING OIL COOLERS TO LAND VEHICLE RADIATORS, NAMELY, METAL BOLTS (U.S. CLS. 2, 12, 13, 14, 23, 25 AND 50).

FIRST USE 10-9-2007; IN COMMERCE 10-9-2007.

CLASS 11—ENVIRONMENTAL CONTROL APPARATUS

FOR REPAIR AND REPLACEMENT PARTS FOR AIR CONDITIONERS AND HEATERS FOR VEHICLES, NAMELY, COMBUSTION ENGINE LAND VEHICLE PARTS IN THE NATURE OF HEATER CORES AND GAS COOLERS; REPLACEMENT PARTS FOR AUTOMOTIVE VEHICLE HEATING APPARATUS, NAMELY, EVAPORATORS, HEATER CORES, HEATER VALVES, HEATER FITTINGS, NAMELY, HOSE CLAMPS, BLOWER MOTORS, AND BLOWER MOTOR WHEELS; REPLACEMENT PARTS FOR AUTOMOTIVE AIR CONDITIONERS, NAMELY, EVAPORATORS, MOTORS, BLOWER MOTORS, VALVES, FANS, FAN BLADES, FAN CLUTCHES, DRYERS AND ELECTRIC EXPANSION VALVES; HEAT EXCHANGERS ADAPTED TO COOL TORQUE CONVERTER FLUID, ENGINE OIL, POWER STEERING FLUID AND OTHER FLUID ASSOCIATED WITH POWER UNITS AND VEHICLES (U.S. CLS. 13, 21, 23, 31 AND 34).

FIRST USE 10-9-2007; IN COMMERCE 10-9-2007.

CLASS 12—VEHICLES

FOR MOTOR VEHICLE LOCKS INCORPORATED INTO THE VEHICLE, NAMELY, MOTOR VEHICLE DOOR LOCKS, MOTOR VEHICLE TRUNK LOCKS, MOTOR VEHICLE IGNITION LOCKS, TRUCK BED COVER "T" HANDLE LOCKS, AND MOTOR VEHICLE GLOVE COMPARTMENT LOCKS (U.S. CLS. 19, 21, 23, 31, 35 AND 44).

FIRST USE 10-9-2007; IN COMMERCE 10-9-2007.
SUE LAWRENCE, EXAMINING ATTORNEY

SN 77-656,629. SHRED-IT INTERNATIONAL, INC., OAKVILLE, CANADA, FILED 1-26-2009.

SECURSHIELD

THE MARK CONSISTS OF STANDARD CHARACTERS WITHOUT CLAIM TO ANY PARTICULAR FONT, STYLE, SIZE, OR COLOR.

PRIORITY CLAIMED UNDER SEC. 44(D) ON CANADA APPLICATION NO. 1405824, FILED 8-1-2008, REG. NO. TMA799,247, DATED 6-3-2011, EXPIRES 6-3-2026.

CLASS 6—METAL GOODS

FOR METAL LOCKS FOR SHREDDING BOXES (U.S. CLS. 2, 12, 13, 14, 23, 25 AND 50).

CLASS 20—FURNITURE AND ARTICLES NOT OTHERWISE CLASSIFIED

FOR NON-METAL AND NON-PAPER SHREDDING BOXES (U.S. CLS. 2, 13, 22, 25, 32 AND 50).

CLASS 40—MATERIAL TREATMENT

FOR DESTRUCTION OF DOCUMENTS AND OTHER FORMS OF RECORDED MEDIA (U.S. CLS. 100, 103 AND 106).

LINDA POWELL, EXAMINING ATTORNEY

SN 77-664,100. LIN, SHENG, BROOKLYN, NY. FILED 2-5-2009.



NO CLAIM IS MADE TO THE EXCLUSIVE RIGHT TO USE "GROVE", APART FROM THE MARK AS SHOWN.

THE NAME SHENG LIN IDENTIFIES A LIVING INDIVIDUAL WHOSE CONSENT IS OF RECORD.

THE COLOR(S) GREEN, BLACK AND WHITE IS/ARE CLAIMED AS A FEATURE OF THE MARK.

THE MARK CONSISTS OF THREE BLACK CHINESE CHARACTERS IN THE CENTER OF A GREEN CIRCLE. GREEN EARS OF WHEAT SURROUND THE THREE BLACK CHINESE CHARACTERS INSIDE THE CIRCLE. THREE ENGLISH WORDS, "GROVE GROW NOTES", APPEAR IN BLACK LETTERS IN THE TOP HALF OF THE GREEN CIRCLE. A WHITE STAR APPEARS BEFORE AND AFTER "GROVE GROW NOTES". THE INTERIOR BACKGROUND OF THE CIRCLE IS WHITE.

THE NON-LATIN CHARACTERS IN THE MARK TRANSLITERATE TO LIN SHENG JI AND THIS HAS NO MEANING IN A FOREIGN LANGUAGE.

CLASS 29—MEATS AND PROCESSED FOODS

FOR ABALONES; ALGAE FOOD BEVERAGES, NAMELY, SEAWEED DRINKS; BLANCHED NUTS; BLOCKS OF BOILED, SMOKED AND THEN DRIED BONITOS (KATSUO-BUSHI); BOTTLED COOKED MEAT; CAFFEINE-COATED NUTS; CANDIED NUTS; CANNED COOKED MEAT; CHICKEN AND DUMPLINGS; CHOCOLATE NUT BUTTER; CHOW MEIN; COFFEE-COATED NUTS; DRIED BEANS; DRIED BEEF; DRIED EDIBLE ALGAE; DRIED EDIBLE SEAWEED (HOSHI-WAKAME); DRIED EGGS; DRIED FIGS; DRIED FLAKES OF LAVER FOR SPRINKLING ON RICE IN HOT WATER (OCHAZUKE-NORI); DRIED FRUIT AND VEGETABLES; DRIED FRUIT MIXES; DRIED FRUITS; DRIED LENTILS; DRIED MEAT; DRIED PIECES OF AGAR JELLY (KANTEN); DRIED SOYBEANS; DRIED VEGETABLES; EDIBLE OILS AND FATS, FISH AND MEAT PRESERVES; FIG AND DATE ROLL CONSISTING OF DRIED FRUITS, NUTS, AND SPICES; FISH AND MEAT PRESERVES; FLAKES OF DRIED FISH MEAT (KEZURI-BUSHI); MEAT, FISH, FRUIT AND VEGETABLE JELLIES; MEAT, FISH, FRUIT AND VEGETABLE PRESERVES; MEAT, FISH, POULTRY AND GAME; MEAT, FISH, POULTRY AND GAME PRESERVES; MEAT, FROZEN; MEAT, FRUIT AND VEGETABLE JELLIES, JAMS; MEAT, FRUIT AND VEGETABLE JELLIES, JAMS, EGGS; MEAT, POULTRY AND GAME; NUT AND SEED-BASED SNACK BARS; NUT BUTTERS; NUT CHEESE, NAMELY, CHEESE-TYPE PRODUCT MADE FROM NUTS; NUT CHEESE; NUT MEATS; NUT TOPPING; NUT-BASED MILK; NUT-BASED SNACK FOODS, NAMELY, NUT CLUSTERS; NUT-BASED SNACK FOODS, NAMELY, NUT CRISPS; ORGANIC NUT AND SEED-BASED SNACK BARS; POTATO DUMPLINGS; PREPARED NUTS; PRESERVED, DRIED AND COOKED FRUIT AND VEGETABLES; PRESERVED, DRIED AND COOKED OLIVES; PRESERVED, DRIED, COOKED AND GRILLED VEGETABLES; PROCESSED BEANS; PROCESSED FRUIT- AND NUT-BASED FOOD BARS; PROCESSED MEAT; PROCESSED NUTS; PROCESSED PIGNOLI PINE NUTS; PROCESSED PUMPKIN SEEDS; PROCESSED SOY BEANS; PROCESSED, EDIBLE SEAWEED; ROASTED NUTS; SEASONED NUTS; SHEETS OF DRIED LAVER (HOSHI-NORI); SHELLED NUTS; SHELLFISH; SHRIMP; SHRIMP CHIPS; SHRIMPS, PRAWNS AND LOBSTERS; SNACK MIX CONSISTING OF DEHYDRATED FRUIT AND PROCESSED NUTS; SNACK MIX CONSISTING OF PRIMARILY OF PROCESSED NUTS AND SALTED SQUASH SEEDS AND ALSO INCLUDING TOASTED CORN; SNACK MIX CONSISTING OF PRIMARILY OF PROCESSED NUTS, SEEDS, DRIED FRUIT AND ALSO INCLUDING CHOCOLATE; TRAIL MIX CONSISTING PRIMARILY OF PROCESSED NUTS, SEEDS, DRIED FRUIT AND ALSO INCLUDING CHOCOLATE (U.S. CL. 46).

CLASS 30—STAPLE FOODS

FOR (BASED ON USE IN COMMERCE) BROWN SUGAR; CUBE SUGAR; HONEY FLAVORED WITH ALOE TEA; HONEY FLAVORED WITH LEMON TEA; SUGAR (BASED ON INTENT TO USE) BEAN-STARCH NOODLES (HARUSAME, UNCOOKED); CAKES OF SUGAR-BOUNDED MILLET OR POPPED RICE (OKOSHI); CHINESE NOODLES; CHINESE RICE NOODLES (BIFUN, UNCOOKED); CHINESE STEAMED DUMPLINGS (SHUMAI, COOKED); CHINESE STUFFED DUMPLINGS (GYOZA, COOKED); CHOW MEIN NOODLES; CRYSTAL SUGAR; CRYSTAL SUGAR PIECES; DRIED CHILI PEPPERS; DRIED CHIVES; DRIED SUGARED CAKES OF RICE FLOUR (RAKUGAN); DUMPLINGS; FISH DUMPLINGS; FLOUR FOR MAKING DUMPLINGS OF GLUTINOUS RICE; HONEY; HONEY AND TREATLE; HONEY BUNS; HONEY SUBSTITUTES; INSTANT CHINESE NOODLES; INSTANT NOODLES; INSTANT SOBA NOODLES; INSTANT UDON NOODLES; MIX FOR MAKING COMBINED NOODLE AND SAUCE DISH; NATURAL BROWN SUGAR; NOODLES; NOODLES AND SAUCE MIXES COMBINED IN UNITARY PACKAGES; NOODLES AND SEASONING MIXES COMBINED IN UNITARY PACKAGES; NOODLES, SAUCE, AND PROCESSED VEGETABLES COMBINED IN UNITARY PACKAGES; NOODLES, SAUCE, AND SEASONING TOPPINGS COMBINED IN UNITARY PACKAGES; NOODLES, SAUCE, AND TOPPING COMBINED IN

UNITARY PACKAGES; NOODLES, SAUCE, DEHYDRATED VEGETABLES, AND TOPPING COMBINED IN UNITARY PACKAGES; NOODLES, SEASONINGS, EDIBLE OIL, AND DEHYDRATED VEGETABLES COMBINED IN UNITARY PACKAGES; NOODLES, SEASONINGS, EDIBLE OIL, AND FLAVORINGS COMBINED IN UNITARY PACKAGES; PASTA AND NOODLES; POWDERED SUGAR; RICE DUMPLINGS DRESSED WITH SWEET BEAN JAM (ANKORO); RICE NOODLES; SHRIMP DUMPLINGS; SOBA NOODLES; SOMEN NOODLES; SWEET DUMPLINGS (DANGO); UDON NOODLES (U.S. CL. 46).

FIRST USE 6-8-2006; IN COMMERCE 6-8-2006.
JEFFREY LOOK, EXAMINING ATTORNEY

SN 77-683,164. MUSIC INDUSTRIES ASSOCIATION OF CANADA-ASSOCIATION CANADIENNE DES INDUSTRIES DE LA MUSIQUE, TORONTO, ONTARIO, CANADA, FILED 3-4-2009.

PAL

THE MARK CONSISTS OF STANDARD CHARACTERS WITHOUT CLAIM TO ANY PARTICULAR FONT, STYLE, SIZE, OR COLOR.

PRIORITY CLAIMED UNDER SEC. 44(D) ON CANADA APPLICATION NO. 1422451, FILED 12-19-2008, REG. NO. TMA793,873, DATED 3-25-2011, EXPIRES 3-25-2026.

CLASS 9—ELECTRICAL AND SCIENTIFIC APPARATUS

FOR DOWNLOADABLE ELECTRONIC PUBLICATIONS IN THE NATURE OF NEWSLETTERS REGARDING THE AUDIO, LIGHTING, VIDEO, STAGING AND PRODUCTION INDUSTRY AND TECHNOLOGIES (U.S. CLS. 21, 23, 26, 36 AND 38).

FIRST USE 0-0-2004; IN COMMERCE 0-0-2004.

CLASS 35—ADVERTISING AND BUSINESS

FOR OPERATING, ARRANGING, ORGANIZING AND CONDUCTING TRADE SHOW EXHIBITIONS IN THE FIELD OF AUDIO/VISUAL PRODUCTION TECHNOLOGY PRODUCTS, AUDIO PRODUCTS, SOUND AND LIGHTING PRODUCTS, VIDEO PRODUCTS, STAGING PRODUCTS, COMPUTER SOFTWARE FOR AUDIO, VIDEO AND STAGING AND COMPUTER HARDWARE FOR AUDIO, VIDEO AND STAGING; ASSOCIATION SERVICES, NAMELY, PROMOTING THE INTERESTS OF AUDIO/VISUAL PRODUCTION TECHNOLOGY, AUDIO, LIGHTING AND STAGE PRODUCTS, MANUFACTURERS AND DISTRIBUTORS; ASSOCIATION SERVICES, NAMELY, PROMOTING THE RIGHTS OF MANUFACTURERS, DISTRIBUTORS AND PERSONS IN THE AUDIO/VISUAL PRODUCTION TECHNOLOGY INDUSTRY AND THE AUDIO, VIDEO AND STAGING INDUSTRY; PROVIDING A WEBSITE FEATURING CONSUMER PRODUCT INFORMATION REGARDING AUDIO/VISUAL PRODUCTION TECHNOLOGY PRODUCTS, AUDIO PRODUCTS, LIGHTING PRODUCTS, VIDEO PRODUCTS, STAGING PRODUCTS, AND BUSINESS INFORMATION ABOUT THE AUDIO/VISUAL PRODUCTION TECHNOLOGY INDUSTRY (U.S. CLS. 100, 101 AND 102).

FIRST USE 0-0-2001; IN COMMERCE 0-0-2001.

CLASS 41—EDUCATION AND ENTERTAINMENT

FOR WORKSHOPS AND SEMINARS IN THE FIELD OF AUDIO/VISUAL PRODUCTION TECHNOLOGY, AUDIO, LIGHTING, VIDEO AND STAGING AND COMPUTER SOFTWARE FOR AUDIO/VISUAL PRODUCTION TECHNOLOGIES; PROVIDING ON-LINE NON-DOWNLOADABLE PUBLICATIONS IN THE NATURE OF NEWSLETTERS IN ELECTRONIC FORM VIA THE INTERNET, REGARDING THE AUDIO/VISUAL PRODUCTION TECHNOLOGY INDUSTRY AND THE AUDIO, LIGHTING, VIDEO AND STAGING INDUSTRY (U.S. CLS. 100, 101 AND 107).

FIRST USE 0-0-2004; IN COMMERCE 0-0-2004.
JEAN IM, EXAMINING ATTORNEY

SN 77-694,767. PUMA DART PRODUCTS LIMITED, KATI-KATI, NEW ZEALAND, FILED 3-19-2009.

SHOT!

THE MARK CONSISTS OF STANDARD CHARACTERS WITHOUT CLAIM TO ANY PARTICULAR FONT, STYLE, SIZE, OR COLOR.

OWNER OF NEW ZEALAND REG. NO. 800869, DATED 12-22-2008, EXPIRES 12-22-2018.

CLASS 28—TOYS AND SPORTING GOODS

FOR DARTS; DART BOARDS; DART BOARDS FEATURING DART BOARD MOUNTING ASSEMBLIES AND DART SCOREBOARDS SOLD AS A UNIT THEREWITH; FLIGHTS AND STEMS FOR DARTS; DART CASES; DART ACCESSORIES, NAMELY, DART BOARD HANGING KITS COMPRISING BRACKETS AND SCREWS, FLIGHT PROTECTORS BEING COVERS SPECIFICALLY ADAPTED FOR DART FLIGHTS, DART POINTS; DART BOARD TOOLS, NAMELY, DART POINT SHARPENERS AND DART POINT PULLERS (U.S. CLS. 22, 23, 38 AND 50).

CLASS 35—ADVERTISING AND BUSINESS

FOR RETAIL STORE AND WHOLESALE DISTRIBUTORSHIP SERVICES, INCLUDING THOSE PROVIDED VIA AN ON-LINE OR ELECTRONIC MEANS, FEATURING DARTS, DART BOARDS, FLIGHTS AND STEMS FOR DARTS, DART CASES, DART SCORE BOARDS BEING SPORTING ARTICLES, AND DART ACCESSORIES (U.S. CLS. 100, 101 AND 102).

MELISSA VALLILLO, EXAMINING ATTORNEY

SN 77-702,171. HOLDING SOPREMA, STRASBOURG 67100, FRANCE, FILED 3-30-2009.



PRIORITY CLAIMED UNDER SEC. 44(D) ON CANADA APPLICATION NO. 1427986, FILED 2-6-2009, REG. NO. TMA764378, DATED 4-19-2010, EXPIRES 4-19-2025.

NO CLAIM IS MADE TO THE EXCLUSIVE RIGHT TO USE "SOUND", APART FROM THE MARK AS SHOWN.

THE MARK CONSISTS OF A WAVE DESIGN INTERRUPTED BY A STYLIZED VERSION OF THE WORDING "RESISTOSOUND".

THE WORDING "RESISTO" HAS NO MEANING IN A FOREIGN LANGUAGE.

CLASS 6—METAL GOODS

FOR CONSTRUCTION MATERIALS FOR RESIDENTIAL AND COMMERCIAL SOUNDPROOFING USES, NAMELY, METAL ANCHORING SYSTEM FOR CEILINGS COMPRISED OF LIGHTWEIGHT STEEL METAL FURRINGS AND LIGHTWEIGHT STEEL METAL ANCHORS (U.S. CLS. 2, 12, 13, 14, 23, 25 AND 50).

CLASS 17—RUBBER GOODS

FOR CONSTRUCTION MATERIALS, NAMELY, NON-METAL SUB-FLOOR SOUNDPROOFING POLYETHYLENE MEMBRANE AND POLYMER MEMBRANE COATED WITH RUBBER GRANULES FOR RESIDENTIAL AND COMMERCIAL USE, CONSTRUCTION MATERIALS IN THE NATURE OF ARCHITECTURAL ACOUSTIC PRODUCTS, NAMELY, A NON-METAL SUB-FLOOR SOUND ABSORBING AND DIFFUSING MEMBRANE FOR COMMERCIAL AND RESIDENTIAL USE; ACOUSTIC INSULATION FOR USE IN AND ON WALLS AND CEILINGS IN THE RESIDENTIAL AND COMMERCIAL CONSTRUCTION AND RENOVATION INDUSTRIES; ACOUSTICAL INSULATION FOR BUILDINGS; SOUNDPROOFING PANELS USED TO SOUND-PROOF TUBS, SPAS, WHIRLPOOL BATHS, THERAPEUTIC BATHS AND SHOWERS (U.S. CLS. 1, 5, 12, 13, 35 AND 50).

SUSAN RICHARDS, EXAMINING ATTORNEY

SN 77-718,290. CRAVE CUPCAKES MANAGEMENT, LLC, HOUSTON, TX. FILED 4-21-2009.

CRAVE

THE MARK CONSISTS OF STANDARD CHARACTERS WITHOUT CLAIM TO ANY PARTICULAR FONT, STYLE, SIZE, OR COLOR.

OWNER OF U.S. REG. NO. 3,509,148.

CLASS 30—STAPLE FOODS

FOR COFFEE, BEVERAGES MADE OF COFFEE, ESPRESSO, CAPPUCINO, LATTE, TEA, HOT COCOA AND BLENDED BEVERAGES MADE OF COFFEE (U.S. CL. 46).

FIRST USE 6-16-2008; IN COMMERCE 6-16-2008.

CLASS 32—LIGHT BEVERAGES

FOR DRINKING WATER (U.S. CLS. 45, 46 AND 48).

FIRST USE 6-16-2008; IN COMMERCE 6-16-2008.
YAT SYE, LEE, EXAMINING ATTORNEY

SN 77-721,107. EURO-PRO OPERATING LLC, NEWTON, MA. FILED 4-23-2009.

SAMURAI

THE MARK CONSISTS OF STANDARD CHARACTERS WITHOUT CLAIM TO ANY PARTICULAR FONT, STYLE, SIZE, OR COLOR.

CLASS 7—MACHINERY

FOR ELECTRIC KITCHEN APPLIANCES FOR HOUSEHOLD USE, NAMELY, ELECTRIC MIXERS, ELECTRIC FOOD AND MEAT GRINDERS, ELECTRIC COFFEE GRINDERS, ELECTRIC JUICERS, ELECTRIC JUICE EXTRACTORS, ELECTRIC FRUIT PRESSES, ELECTRIC EGG BEATERS, ELECTRIC WHISKS, ELECTRIC GRATERS, ELECTRIC PASTA MAKERS AND ELECTRIC CAN OPENERS (U.S. CLS. 13, 19, 21, 23, 31, 34 AND 35).

CLASS 11—ENVIRONMENTAL CONTROL APPARATUS

FOR ELECTRIC COOKWARE AND BAKEWARE, FOR HOUSEHOLD USE, NAMELY, ELECTRIC FRY PANS, ELECTRIC ROASTERS, ELECTRIC BROILERS, ELECTRIC GRILLS, ELECTRIC CASSEROLES, ELECTRIC ROTISSERIES, ELECTRIC PRESSURE COOKERS, ELECTRIC RICE COOKERS, ELECTRIC DUTCH OVENS, ELECTRIC COOKING OVENS, ELECTRIC TOASTER OVENS, ELECTRIC WAFFLE IRONS, ELECTRIC HOT-PLATES, ELECTRIC FOOD STEAMERS, ELECTRIC FOOD WARMERS, ELECTRIC BREAD COOKERS AND ELECTRIC EGG BOILERS; ELECTRIC TOASTERS; ELECTRIC COFFEE MAKERS; ELECTRIC KETTLES; ELECTRIC ICE CREAM MAKERS; AND ELECTRIC YOGURT MACHINES (U.S. CLS. 13, 21, 23, 31 AND 34).

EMILY CHUO, EXAMINING ATTORNEY

SN 77-722,039. NOBLIS, INC., FALLS CHURCH, VA. FILED 4-24-2009.

TEAL

THE MARK CONSISTS OF STANDARD CHARACTERS WITHOUT CLAIM TO ANY PARTICULAR FONT, STYLE, SIZE, OR COLOR.

CLASS 35—ADVERTISING AND BUSINESS

FOR CONSULTING SERVICES IN THE FIELD OF ENERGY EFFICIENCY RELATING TO THE USE OF ENERGY, ENERGY EFFICIENCY, AND CONSERVATION OF ENERGY TO PROVIDE CORRECTIVE ACTIONS TO REDUCE AND MITIGATE GREENHOUSE GAS (GHG) EMISSIONS (U.S. CLS. 100, 101 AND 102).

FIRST USE 5-13-2009; IN COMMERCE 5-13-2009.

CLASS 40—MATERIAL TREATMENT

FOR CONSULTING SERVICES, NAMELY, CONSULTATION AND ASSISTANCE TO PROVIDE CORRECTIVE ACTIONS TO REDUCE AND MITIGATE GREENHOUSE GAS (GHG) EMISSIONS THROUGH CHEMICAL OR MECHANICAL PROCESSING; CONSULTING SERVICES IN THE FIELD OF WASTE REDUCTION AND WASTE RECYCLING, FOR THE BENEFIT OF BUSINESS AND THE ENVIRONMENT TO PROVIDE CORRECTIVE ACTIONS TO REDUCE AND MITIGATE GREENHOUSE GAS EMISSIONS (U.S. CLS. 100, 103 AND 106).

FIRST USE 5-13-2009; IN COMMERCE 5-13-2009.

CLASS 42—SCIENTIFIC AND COMPUTER SERVICES

FOR APPLICATION SERVICE PROVIDER (ASP) FEATURING A WEB-BASED TOOL FOR CALCULATING, ANALYZING, VISUALIZING, INVENTORYING, BENCHMARKING, AND REPORTING GREEN HOUSE GAS (GHG) EMISSIONS; CONSULTING SERVICES, IN THE FIELD OF ENGINEERING, NAMELY, ENGINEERING CONSULTATION AND ASSISTANCE TO PROVIDE CORRECTIVE ACTIONS TO REDUCE AND MITIGATE GREEN HOUSE EMISSIONS; CONSULTATION SERVICES IN THE NATURE OF DESIGNING PROJECTS THAT REDUCE OR MITIGATE GREENHOUSE GAS EMISSIONS, AND TECHNICAL ASSISTANCE TO VERIFY EMISSION REDUCTIONS FOR THE PURPOSE OF CERTIFICATION (U.S. CLS. 100 AND 101).

FIRST USE 5-13-2009; IN COMMERCE 5-13-2009.
ALLISON HOLTZ, EXAMINING ATTORNEY

SN 77-754,733, OMNIMART DISTRIBUTIONS INC., EDMONTON, ALBERTA, CANADA, FILED 6-8-2009.

HOT GLUE2

THE MARK CONSISTS OF STANDARD CHARACTERS WITHOUT CLAIM TO ANY PARTICULAR FONT, STYLE, SIZE, OR COLOR.

PRIORITY CLAIMED UNDER SEC. 44(D) ON CANADA APPLICATION NO. 1422317, FILED 12-18-2008, REG. NO. TMA787532, DATED 1-17-2011, EXPIRES 1-17-2026.

OWNER OF U.S. REG. NO. 3,352,080.

CLASS 7—MACHINERY

FOR POWER-OPERATED TOOLS FOR JOINING AND SEAMING PLANAR MATERIALS TOGETHER, NAMELY, CARPET AND RESILIENT SHEET MATERIAL MADE OF RUBBER, VINYL, POLYESTER, URTHANE OR LINOLEUM, AND PARTS THEREFOR (U.S. CLS. 13, 19, 21, 23, 31, 34 AND 35).

CLASS 8—HAND TOOLS

FOR HAND-OPERATED TOOLS FOR JOINING AND SEAMING PLANAR MATERIALS TOGETHER, NAMELY, CARPET AND RESILIENT SHEET MATERIAL MADE OF RUBBER, VINYL, POLYESTER, URTHANE OR LINOLEUM, AND PARTS THEREFOR; HAND-OPERATED TOOLS FOR JOINING AND SEAMING PLANAR MATERIALS TOGETHER, NAMELY, APPLICATOR TIPS, SUPPORT STANDS FOR APPLICATOR TIPS, COUPLING ADAPTORS FOR APPLICATOR TIPS, AND PARTS THEREFOR (U.S. CLS. 23, 28 AND 44).

DAVID MILLER, EXAMINING ATTORNEY

SN 77-777,760, CANTATA, L.P., GRAND CAYMAN, CAYMAN ISLANDS, FILED 7-9-2009.

EMMA WATSON

THE MARK CONSISTS OF STANDARD CHARACTERS WITHOUT CLAIM TO ANY PARTICULAR FONT, STYLE, SIZE, OR COLOR.

OWNER OF ERPN CMNTY TM OFC REG. NO. 008414252, DATED 2-17-2010, EXPIRES 7-8-2019.

THE NAME(S), PORTRAIT(S), AND/OR SIGNATURE(S) SHOWN IN THE MARK IDENTIFIES "EMMA WATSON", WHOSE CONSENT(S) TO REGISTER IS MADE OF RECORD.

CLASS 3—COSMETICS AND CLEANING PREPARATIONS

FOR PERFUMES; TOILET WATERS; EAU DE COLOGNE; ESSENTIAL OILS FOR PERSONAL USE; COSMETICS; COSMETICS, NAMELY, EYE SHADOW, LIP GLOSS, LIPSTICK, MASCARA, FOUNDATION MAKE-UP; TOILET PREPARATIONS, NAMELY, TOILET WATER, EAU DE TOILETTE; SOAPS; ANTIPERSPIRANTS; DEODORANTS FOR PERSONAL CARE; HAIR CARE PREPARATIONS; SKIN CARE PREPARATIONS, NAMELY, SKIN LOTIONS, SKIN CREAMS, SKIN CLEANSERS, SKIN CLEANSING LOTION, SKIN CONDITIONERS, SKIN GELS, SKIN CONDITIONING CREAMS FOR COSMETIC PURPOSES, WRINKLE REMOVING SKIN CARE PREPARATIONS, SKIN MOISTURIZER; SHAMPOOS; CONDITIONERS; BEAUTY CARE PREPARATIONS, NAMELY, BEAUTY CREAMS, BEAUTY GELS, BEAUTY LOTIONS, BEAUTY MILKS, BEAUTY SERUMS; BEAUTY MASKS; BODY CARE PREPARATIONS, NAMELY, BODY CREAM, BODY MASKS, BODY OIL, BODY POWDER, BODY SCRUBS, BODY LOTIONS, BODY SPLASH, BODY CREAM SOAP, AROMATHERAPY BODY CARE PRODUCTS, NAMELY, BODY LOTION, SHOWER GEL, CUTICLE CREAM, SHAMPOO, CONDITIONER, NON-MEDICATED LIP BALM, SOAP, BODY POLISH, BODY AND FOOT SCRUB, NON-MEDICATED FOOT CREAM, NATURAL COCOA BUTTER, SHEA NUT BUTTER, SUGAR OR BRAZIL NUT OIL BASED BODY AND SKIN CARE PRODUCTS, NAMELY, LOTIONS, POLISHES, CREAMS, CLEANSERS, CLEANSING LOTIONS, CONDITIONERS, GELS, MOISTURISERS, MILKS, MASKS, OILS, POWDERS, SCRUBS, SPLASH, SOAPS; DENTIFRICES; SHAVING PREPARATIONS, DYES FOR HAIR; NON-MEDICATED BATH PREPARATIONS; BATH PREPARATIONS, NAMELY, BEADS, CRYSTALS, FOAM, GELS, OIL AND POWDER; SCENTED BODY SPRAYS; AFTER-SHAVE LOTIONS; PRE-ELECTRIC SHAVING PREPARATIONS, NAMELY, AFTER SHAVE LOTIONS, AFTER-SHAVE BALMS, AFTER-SHAVE CREAMS, AFTER-SHAVE GEL, PRE-SHAVE LIQUID, PRE-SHAVE CREAMS; SHAVING BALM, SHAVING CREAM, SHAVING FOAM, SHAVING GEL, SHAVING LOTION, SHAVING MOUSSE, SHAVING SOAP (U.S. CLS. 1, 4, 6, 50, 51 AND 52).

CLASS 6—METAL GOODS

FOR GOODS MADE WHOLLY OR PRINCIPALLY OF NON-PRECIOUS METAL, NAMELY, KEYS, KEY BLANKS, KEY RINGS, KEY FOBS, KEY CHAINS, IDENTIFICATION TAGS OF METAL, LOCKS, FIGURINES OF METAL, TROPHIES, STATUES AND STATUETTES, BOXES, MONEY BOXES; TOOL BOXES; METAL NAME BADGES (U.S. CLS. 2, 12, 13, 14, 23, 25 AND 50).

CLASS 9—ELECTRICAL AND SCIENTIFIC APPARATUS

FOR PRE-RECORDED VINYL RECORDS, COMPACT DISCS, AUDIO TAPES, AUDIO-VIDEO TAPES, AUDIO VIDEO CASSETTES, AUDIO VIDEO DISCS, AND DIGITAL VERSATILE DISCS FEATURING CHILDREN'S ENTERTAINMENT, ANIMATION, MUSIC, COMEDY, VARIETY, ADVENTURE OR DRAMA; PRE-RECORDED VIDEO RECORDINGS FEATURING CHILDREN'S ENTERTAINMENT ANIMATION, MUSIC, COMEDY, VARIETY, ADVENTURE OR DRAMA; MOTION PICTURE FILMS FEATURING CHILDREN'S ENTERTAINMENT, ANIMATION, MUSIC, COMEDY, VARIETY, ADVENTURE OR DRAMA AND DOWNLOADABLE TELEVISION PROGRAMMES FEATURING CHILDREN'S ENTERTAINMENT, ANIMATION, MUSIC, COMEDY, VARIETY, ADVENTURE OR DRAMA; MOTION PICTURE FILM FEATURING CHILDREN'S ENTERTAINMENT, ANIMATION, MUSIC, COMEDY, VARIETY, ADVENTURE OR DRAMA FOR BROADCAST ON TELEVISION; CD-ROMS FEATURING CHILDREN'S ENTERTAINMENT, ANIMATION, MUSIC, COMEDY, VARIETY, ADVENTURE OR DRAMA; COMPUTER GAME SOFTWARE RECORDED ON CD-ROM; BLANK AUDIO TAPES, BLANK VIDEO TAPES, BLANK AUDIO CASSETTES, BLANK VIDEO CASSETTES; VIDEO GAMES ADAPTED FOR USE WITH TELEVISION RECEIVERS; VIDEO AND COMPUTER GAMES SOFTWARE; VIDEO GAME CARTRIDGES AND CASSETTES; GAME EQUIPMENT FOR PLAYING A COMPUTER GAME, NAMELY, JOYSTICKS, 3D GLASSES, HEADSETS, GAME CONTROLLERS; SPECTACLES, SPECTACLE CASES, SUNGLASSES; COMPUTER SOFTWARE FOR ARCADE-BASED VIDEO GAME CONSOLES; VIDEO GAMES SOFTWARE; COMPUTER PERIPHERAL MOUSE PADS; COMPUTER SCREEN SAVERS SOFTWARE; HAND-HELD UNITS FOR PLAYING ELECTRONIC GAMES FOR USE WITH EXTERNAL DISPLAY SCREEN OR MONITOR (U.S. CLS. 21, 23, 26, 36 AND 38).

CLASS 14—JEWELRY

FOR GOODS MADE WHOLLY OR PRINCIPALLY OF PRECIOUS METALS AND THEIR ALLOYS OR COATED THEREWITH, NAMELY, TROPHIES, ORNAMENTS, FIGURINES, COMMEMORATIVE STATUARY CUPS, JEWELLERY BOXES, WATCH CASES, JEWELLERY CASES; CLOCKS, ALARM CLOCKS; WATCHES; JEWELLERY; PRECIOUS STONES, NAMELY, DIAMONDS, RUBIES, SAPPHIRES; BRACELETS, JEWELLERY CHAINS, WATCH CHAINS, NON-MONETARY COINS, MEDALS, MEDALLIONS, KEY RINGS OF PRECIOUS METAL, TIE CLIPS, TIE PINS, CUFFLINKS; JEWELLERY PINS FOR USE ON HATS; JEWELLERY PINS; ORNAMENTAL LAPEL PINS; DECORATIVE BOXES MADE WHOLLY OR PRINCIPALLY OF PRECIOUS METALS AND THEIR ALLOYS OR COATED THEREWITH (U.S. CLS. 2, 27, 28 AND 50).

CLASS 16—PAPER GOODS AND PRINTED MATTER

FOR PRINTER MATTER, NAMELY, GENERAL FEATURE MAGAZINES, PRINTED MATTER, NAMELY, NEWSPAPERS, PRINTED PERIODICAL PUBLICATIONS, MAGAZINES, GENERAL FEATURE MAGAZINES, BOOKS, COMIC BOOKS AND NEWSLETTERS FEATURING CHILDREN'S ENTERTAINMENT, MUSIC, COMEDY, VARIETY, ADVENTURE, FASHION, ENTERTAINMENT OR DRAMA FEATURES; COLOURING BOOKS; CHILDREN'S ACTIVITY BOOKS; UNMOUNTED PHOTOGRAPHS, MOUNTED PHOTOGRAPHS; PICTURES, ART PRINTS, PHOTOGRAPHIC PRINTS, POSTERS; GREETING CARDS; POSTCARDS; NOTEPADS; ADDRESS PADS; SCRAP BOOKS; FOLDERS; CALENDARS; PHOTOGRAPH ALBUMS; DIARIES; POSTAGE STAMPS; STAMP ALBUMS; STICKERS, CAR STICKERS; DECALCOMANIAS; STATION-

ERY; PENS, PENCILS, ERASERS, PENCIL SHARPENERS, PENCIL CASES, DRAWING RULERS, BOXES FOR PENS, BOOK MARKS; PRINTED INSTRUCTIONAL AND TEACHING MATERIALS, ALL FEATURING CHILDREN'S ENTERTAINMENT, MUSIC, COMEDY, VARIETY, ADVENTURE, FASHION, ENTERTAINMENT OR DRAMA FEATURES; PAPER GIFT BAGS; ENVELOPES; BLACKBOARDS; PAPER HEIGHT CHARTS; PAPER COVERS FOR PROTECTING STAMPS; CHEQUE BOOK HOLDERS; PAPER PARTY FAVOURS; PAPER AND PLASTIC BAGS FOR STORING RECORDS (U.S. CLS. 2, 5, 22, 23, 29, 37, 38 AND 50).

CLASS 18—LEATHER GOODS

FOR ARTICLES OF LEATHER OR IMITATION LEATHER, NAMELY, SHOPPING BAGS, BRIEFCASES, WRIST MOUNTED CARRYALLS, RUCKSACKS, ALL PURPOSE SPORTS BAGS, ATHLETIC BAGS, BABY BACK PACKS, BACK PACKS, BEACH BAGS, BOOK BAGS, DIAPER BAGS, DUFFEL BAGS, GYM BAGS, TOTE BAGS; SATCHELS; WALLET; COIN PURSES; POUCHES, NAMELY, LEATHER POUCHES, FELT POUCHES, POUCHES FOR HOLDING MAKE-UP, KEYS AND OTHER PERSONAL ITEMS, WEARABLE STRAPON POUCHES; KNAPSACKS; WAIST PACKS, UMBRELLAS, PARASOLS; BUSINESS CARD CASES (U.S. CLS. 1, 2, 3, 22 AND 41).

CLASS 21—HOUSEWARES AND GLASS

FOR BEVERAGE GLASSWARE, CUPS, MUGS, CHINA DINNER PLATES; DOMESTIC UTENSILS, NAMELY, STRAINERS, SIEVES, GRATERS, POT AND PAN SCRAPPERS, ROLLING PINS, KITCHEN TONGS, SKIMMERS, SPATULAS, TURNERS, WHISKS; CONTAINERS FOR HOUSEHOLD USE; HOUSEHOLD CONTAINERS, NAMELY, CONTAINERS FOR FOOD AND SOAP CONTAINERS, NONE BEING OF PRECIOUS METAL OR COATED THEREWITH; DRINKING GLASSES, NAMELY, BEER AND WINE GLASSES AND WHISKY AND WHISKEY SHOT GLASSES, TUMBLERS; CROCKERY, NAMELY, PLATES, CUPS, BOWLS; MUGS; PLASTIC SERVING TRAYS, HAIR COMBS, FLASKS, PLASTIC COASTERS, LUNCH BOXES, NON-METAL PIGGY BANKS, PLASTIC WATER BOTTLES SOLD EMPTY, TOOTH BRUSHES, CONTAINERS FOR HOUSEHOLD OR KITCHEN USE, NOT MADE OF PRECIOUS METALS OR COATED THEREWITH; FIGURINES MADE OF CHINA, CRYSTAL, EARTHENWARE, GLASS, PORCELAIN OR TERRACOTTA; GOODS MADE WHOLLY OR PRINCIPALLY OF PRECIOUS METAL AND THEIR ALLOYS OR COATED WITHIN, NAMELY, COFFEEPOTS, TEAPOTS, GOBLETS, SERVING TRAYS, VASES; CONTAINERS FOR HOUSEHOLD USE; HOUSEHOLD UTENSILS, NAMELY, WHISKS, SPATULAS, LADLES; TOWEL BARS AND NAPKIN HOLDERS; PAPER TRAYS (U.S. CLS. 2, 13, 23, 29, 30, 33, 40 AND 50).

CLASS 24—FABRICS

FOR TEXTILE ARTICLES, NAMELY, BED LINEN, DUVET COVERS, PILLOW CASES, BED SHEETS, BED BLANKETS; TABLE LINEN; TABLE CLOTHS OF TEXTILE, TEXTILE NAPKINS, HANDKERCHIEFS, CURTAINS, CLOTH PENNANTS, CLOTH BANNERS, CLOTH FLAGS, TOWELS, BEACH TOWELS, TEXTILE WALL HANGINGS, FACE TOWELS, TEA TOWELS, FLANNELS, TEXTILE PLACE MATS AND SILK FABRICS (U.S. CLS. 42 AND 50).

CLASS 25—CLOTHING

FOR CLOTHING, NAMELY, SHIRTS, SWEATSHIRTS, JACKETS, SUITS, COATS, RAINCOATS, SNOWSUITS, PANTS, TROUSERS, JEANS, SHORTS, TANK TOPS, T-SHIRTS, RAINWEAR, CLOTH BIBS, SKIRTS, BLOUSES, DRESSES, SUSPENDERS, SWEATERS, ATHLETIC UNIFORMS, WARM-UP SUITS, JOGGING SUITS, BELTS, BOOTIES, SLIPPER SOCKS, SWIMWEAR, SCARVES, DRESSING GOWNS, BOXER SHORTS, SOCKS, T-SHIRTS; SLEEPWEAR, NIGHTGOWNS, PAJAMAS, STOCKINGS, TIGHTS, UNDERWEAR, LINGERIE, WRIST BANDS, HEAD BANDS, TIES, ROBES; FANCY DRESS COSTUMES, NAMELY, FANCY DRESS HAL-

LOWEEN COSTUMES, FANCY DRESS MASQUERADE COSTUMES, FANCY DRESS COSTUMES FOR USE IN ROLE PLAYING GAMES, FANCY DRESS COSTUMES FOR USE IN CHILDREN'S DRESS UP PLAY; FOOTWEAR; SHOES, BOOTS, SNEAKERS, SANDALS, SLIPPERS; HEADGEAR, NAMELY, HATS, CAPS, SUN VISORS; FOOTWEAR AND HEADWEAR FOR BABIES AND TODDLERS; ARTICLES OF CLOTHING FOR BABIES AND TODDLERS, NAMELY, SHIRTS, T-SHIRTS, SHORTS, JACKETS, SOCKS AND DRESSES; SKI BOOT BAGS FOR TRAVEL; COSTUMES FOR USE IN CHILDREN'S DRESS UP PLAY (U.S. CLS. 22 AND 39).

SN 77-778,580. DIAL-AN-ANGEL PTY LIMITED, NSW 2000, AUSTRALIA, FILED 7-10-2009.



CLASS 28—TOYS AND SPORTING GOODS

FOR TOYS, GAMES AND PLAYTHINGS, NAMELY, FANTASY CHARACTER TOYS, BATTERY OPERATED ACTION TOYS, ELECTRIC ACTION TOYS, PLASTIC CHARACTER TOYS, BOARD GAMES, PUPPETS, CARD GAMES, PLAYING CARDS, DOLLS, BATH TOYS, BENDABLE TOYS, CHILDREN'S MULTIPLE ACTIVITY TOYS, CHILDREN'S TOY BICYCLES OTHER THAN FOR TRANSPORT, CLOCKWORK TOYS, CONSTRUCTION TOYS, DRAWING TOYS, MUSICAL TOYS, PLAY HOUSES, PLAY MATS FOR USE WITH TOY VEHICLES; PLAY MATS CONTAINING INFANT TOYS; PLUSH TOYS, POP-UP TOYS, TALKING TOYS, TOY FIGURES, TOY WATCHES, ACTION SKILL GAMES, AMUSEMENT GAME MACHINES, DICE GAMES, HAND-HELD UNITS FOR PLAYING ELECTRONIC OR VIDEO GAMES OTHER THAN THOSE ADAPTED FOR USE WITH AN EXTERNAL DISPLAY SCREEN OR MONITOR; PARTY GAMES, PUZZLE GAMES, ROLE PLAYING GAMES, TRIVIA GAME WITH CARDS AND GAME COMPONENTS; ACTION FIGURES AND ACCESSORIES THEREFOR; BATHTUB TOYS; RIDE-ON TOYS; EQUIPMENT SOLD AS A UNIT FOR PLAYING CARD GAMES; TOY VEHICLES; DOLLS; FLYING DISCS; EQUIPMENT SOLD AS A UNIT FOR PLAYING A BOARD GAME, A CARD GAME, A MANIPULATIVE GAME, A PARLOUR GAME AND AN ACTION TYPE TARGET GAME; STAND ALONE VIDEO OUTPUT GAME MACHINES; BOARD GAMES, CARD GAMES; TEDDY BEARS, PLUSH TOYS; JIGSAW PUZZLES, CUBE PUZZLES, MANIPULATIVE PUZZLES; BALLOONS; PAPER FACE MASKS; SKATEBOARDS; ICE SKATES; ROLLER SKATES; SKIS; WATER SQUIRTING TOYS; SURFBOARDS; SWIMBOARDS FOR RECREATIONAL USE; SWIM FINS; TOY BAKEWARE AND TOY COOKWARE; TOY MODEL HOBBYCRAFT KITS; CHRISTMAS TREE ORNAMENTS; ORDINARY PLAYING CARDS; COSTUME MASKS (U.S. CLS. 22, 23, 38 AND 50).

CLASS 41—EDUCATION AND ENTERTAINMENT

FOR ENTERTAINMENT SERVICES, NAMELY, MOTION PICTURES, THEATER PRODUCTIONS AND TELEVISION SHOWS IN THE FIELD OF CHILDREN'S ENTERTAINMENT, ANIMATION, MUSIC, COMEDY, VARIETY, ADVENTURE OR DRAMA; LIVE MUSIC CONCERTS AND LIVE MUSICAL PERFORMANCES; TELEVISION AND RADIO ENTERTAINMENT SERVICES, NAMELY, PROVIDING AN ON-GOING TELEVISION AND RADIO PROGRAMME IN THE FIELD OF CHILDREN'S ENTERTAINMENT, ANIMATION, MUSIC, COMEDY, VARIETY, ADVENTURE OR DRAMA; ENTERTAINMENT SERVICES, NAMELY, THEATRE PRODUCTIONS AND CABARETS; PRODUCTION OF SOUND AND VIDEO RECORDINGS; PRODUCTION OF MUSICAL SHOWS, CONCERTS, VIDEOS, MULTIMEDIA VIDEOS AND RADIO AND TELEVISION PROGRAMMES; PRESENTATION OF LIVE SHOW PERFORMANCES; RECORDING STUDIO SERVICES, NAMELY, FILM, VIDEO AND TELEVISION RECORDING STUDIOS; AUDIO AND VIDEO RECORDING SERVICES; PUBLISHING OF BOOKS, MAGAZINES, E-BOOKS, AUDIO BOOKS, MUSIC AND ILLUSTRATIONS, ELECTRONIC PUBLICATIONS; MUSIC PUBLISHING; PRODUCTION AND DISTRIBUTION OF FILMS; ARRANGING AND CONDUCTING OF SEMINARS, CONFERENCES AND EXHIBITIONS FOR ENTERTAINMENT PURPOSES; PUBLICATION OF BOOKS, MAGAZINES AND OTHER TEXTS (U.S. CLS. 100, 101 AND 107).
KAPIL BHANOT, EXAMINING ATTORNEY

OWNER OF AUSTRALIA REG. NO. 738623, DATED 7-7-1997, EXPIRES 7-7-2017.

THE MARK CONSISTS OF THE WORDS "DIAL AN ANGEL" IN LOWERCASE FONT, PLACED TO THE RIGHT OF AN IMAGE OF A HOUSE. SUPERIMPOSED ON THE HOUSE IS THE IMAGE OF AN ANGEL PUSHING A VACUUM CLEANER AND HOLDING A CHILD. BEHIND THE ANGEL ARE CARICATURES OF CHILDREN.

CLASS 37—CONSTRUCTION AND REPAIR

FOR CARPET AND RUG CLEANING; CLEANING OF RESIDENTIAL HOUSES (U.S. CLS. 100, 103 AND 106).

CLASS 43—HOTEL AND RESTAURANT SERVICES

FOR CHILD CARE; CHILD CARE SERVICES (U.S. CLS. 100 AND 101).

CLASS 44—MEDICAL, BEAUTY AND AGRICULTURAL SERVICES

FOR GARDEN OR FLOWER BED CARE; GARDENER AND GARDENING SERVICES; HOME HEALTH CARE SERVICES; HOME NURSING AID SERVICES; MEDICAL SERVICES; NURSING CARE; NURSING HOMES (U.S. CLS. 100 AND 101).

CLASS 45—PERSONAL AND LEGAL SERVICES

FOR HOME SITTING; PERSONAL CARE ASSISTANCE OF ACTIVITIES OF DAILY LIVING, SUCH AS BATHING, GROOMING AND PERSONAL MOBILITY FOR MENTALLY OR PHYSICALLY CHALLENGED PEOPLE (U.S. CLS. 100 AND 101).

JAMES GRIFFIN, EXAMINING ATTORNEY

SN 77-786,492. BEATS ELECTRONICS, LLC, SANTA MONICA, CA. FILED 7-21-2009.

BEATS BY DR. DRE

THE MARK CONSISTS OF STANDARD CHARACTERS WITHOUT CLAIM TO ANY PARTICULAR FONT, STYLE, SIZE, OR COLOR.

PRIORITY CLAIMED UNDER SEC. 44(D) ON ERPN CMNTY TM OFC APPLICATION NO. 008370827, FILED 6-17-2009.

OWNER OF U.S. REG. NO. 3,532,627.

THE NAME(S), PORTRAIT(S), AND/OR SIGNATURE(S) SHOWN IN THE MARK IDENTIFIES ANDRE YOUNG A/K/A "DR. DRE", WHOSE CONSENT(S) TO REGISTER IS MADE OF RECORD.

CLASS 9—ELECTRICAL AND SCIENTIFIC APPARATUS

FOR AUDIO AND VIDEO EQUIPMENT, NAMELY, DIGITAL AUDIO PLAYERS, DIGITAL VIDEO PLAYERS, MEDIA PLAYERS, PORTABLE MEDIA PLAYERS, DVD PLAYERS, PORTABLE DVD PLAYERS, CD PLAYERS, PORTABLE CD PLAYERS, MEDIA PLAYERS FOR AUTOMOBILES, DVD PLAYERS FOR AUTOMOBILES, CD PLAYERS FOR AUTOMOBILES, DIGITAL AUDIO PLAYERS, DIGITAL VIDEO PLAYERS, PORTABLE DIGITAL AUDIO PLAYERS, PORTABLE DIGITAL VIDEO PLAYERS; DIGITAL AUDIO PLAYERS FOR AUTOMOBILES; DIGITAL VIDEO PLAYERS FOR AUTOMOBILES; MP3 PLAYERS; MP4 PLAYERS; PROTECTIVE CARRYING CASES FOR PORTABLE MUSIC PLAYERS; CELL PHONES; PERSONAL DIGITAL ASSISTANTS (PDA); SMART PHONES; HEADSETS FOR MOBILE PHONES; AUDIO SPEAKERS; CAR AUDIO SPEAKERS; LOUDSPEAKERS; LOUDSPEAKER CABINETS; HORNS FOR LOUDSPEAKERS; RACKS FOR LOUDSPEAKERS; ELECTRIC ACTUATORS; STANDS SPECIALLY ADAPTED FOR STEREO AND AUDIO SPEAKERS, NAMELY, FLOOR STANDS AND TABLE TOPS FOR LOUDSPEAKERS; SURROUND SOUND SYSTEMS; AUDIO EQUIPMENT, NAMELY, AMPLIFIERS, SUBWOOFERS, SURROUND SOUND SYSTEMS; PRE-AMPLIFIERS; AMPLIFIERS; SOUND AMPLIFIERS; AUDIO AMPLIFIERS; RACKS FOR AMPLIFIERS; HIGH-FIDELITY STEREO SYSTEMS COMPRISED OF AMPLIFIERS, LOUDSPEAKERS, RECEIVERS AND TUNERS; SIGNAL PROCESSORS, NAMELY, SIGNAL SEPARATING, DISTRIBUTING, GENERATING AND CONVERTING CIRCUITS ALL FOR AUDIO SIGNALS, VIDEO SIGNALS OR AUDIO-VIDEO SIGNALS; ELECTRO ACOUSTIC TRANSDUCERS; AUDIO MIXERS; ELECTRONIC AUDIO MIXERS; SOUND MIXERS; SOUND MIXERS WITH INTEGRATED AMPLIFIERS; ACOUSTIC CONDUITS; ACOUSTIC COUPLERS; ACOUSTIC COUPLING DEVICES; ACOUSTIC MEMBRANES; ACOUSTIC METERS; ACOUSTIC SEPARATION UNITS; APPARATUS FOR WIRELESS TRANSMISSION OF ACOUSTIC INFORMATION; WAVE REFLECTORS FOR ACOUSTIC SPEAKERS, LIGHTING APPARATUS, AND AIR FLOW DEVICES; ELECTRICAL PICKUPS FOR USE WITH MUSICAL INSTRUMENTS; MUSICAL JUKE BOXES; MUSICAL INSTRUMENT ADAPTORS; MUSICAL INSTRUMENT AMPLIFIERS; MUSICAL INSTRUMENT CONNECTORS; METRONOMES; TIME CLOCKS BEING TIME RECORDING DEVICES; TELEPRINTERS; SCALES; MICROMETERS; SIGNAL BELLS, SOUND LOCATING INSTRUMENTS, NAMELY, SOUND ALARMS, SOUND LEVEL METERS; PROJECTION SCREENS; AUTOMATIC SWITCHBOARDS; AUTOMATIC TURNSTILES; STEREO RECEIVERS; STEREO TUNERS; STEREO AMPLIFIERS; AUDIO EQUIPMENT COMPONENTS, NAMELY, LIMITERS AND COMPRESSORS, BOXES SPECIALLY ADAPTED FOR HOUSING AUDIO EQUIPMENT, SOFTWARE TO CONTROL AND IMPROVE AUDIO EQUIPMENT SOUND QUALITY; VIDEO EQUIPMENT, NAMELY, VIDEO RECEIVERS, COMBINATION VIDEO PLAYERS AND RECORDERS, DIGITAL VIDEO RECORDERS, DISTRIBUTION AMPLIFIERS FOR VIDEO SIGNALS; VIDEO EQUIPMENT COMPONENTS, NAMELY, COMPONENT VIDEO CABLES, ELECTRONIC SCALERS FOR VIDEO SIGNALS, ELECTRONIC INTERCONNECTERS FOR VIDEO SIGNALS; MICROPHONES; ELECTRONIC CABLES, NAMELY, AUDIO AND VIDEO ELECTRIC CABLES AND CABLE CONNECTORS; POWER CABLES AND CABLE CONNECTORS; SOUND AND VIDEO RECORDING APPARATUS; PORTABLE TELEPHONES AND ACCESSORIES, NAMELY, CASES FOR CELLULAR TELEPHONES, DECORATIVE CHARMS FOR CELLULAR TELEPHONES, FITTED PLASTIC FILMS KNOWN AS SKINS FOR COVERING AND PROVIDING A SCRATCH PROOF BARRIER OR PROTECTION FOR PORTABLE TELEPHONES; COMPACT DISC PLAYERS; RECORD PLAYERS AND EQUIPMENT, NAMELY, NEEDLES FOR RECORD PLAYERS, ELECTRICAL PHONOGRAPH RECORD TURNTABLE CARTRIDGES, PHONOGRAPHIC RECORD CLEANING KITS COMPRISED PRIMARILY OF REPLACEMENT STYLUS NEEDLES AND ALSO INCLUDING CLEANING SOLUTION AND BRUSHES; STEREO PLAYERS AND EQUIPMENT, NAMELY, STEREO TUNERS, STEREO AMPLIFIERS, PERSONAL STEREO; EYEWEAR AND SUNGLASSES; HEADPHONES; COMPUTERS; LAPTOP COMPUTERS; COMPONENTS FOR COMPUTERS FOR ENHANCING

THEIR AUDIO AND VIDEO SOUND PROPERTIES; COMPUTER SOFTWARE, NAMELY SOFTWARE FOR PROCESSING DIGITAL MUSIC FILES AND SOFTWARE FOR BROWSING OR EDITING VIDEO, IMAGES AND SOUND; COMPUTER SOFTWARE, NAMELY SOFTWARE APPLICATION FOR LOCATING AND IDENTIFYING LOCAL MUSIC VENUES AND LIVE MUSICAL OR DJ PERFORMANCES; AUDIO APPLICATION SOFTWARE FOR COMPUTERS; COMPUTER ACCESSORIES, NAMELY USB STICKS, USB HUBS, KEYBOARDS, COMPUTER MONITORS, COMPUTER MOUSE, AND AUDIO SPEAKERS FOR COMPUTERS; ELECTRONIC DEVICES, NAMELY, TELEVISIONS, RADIOS, MP3 PLAYERS, MP4 PLAYERS, VIDEO PLAYERS AND AUDIO PLAYERS, ALL WITH SOUND ELEMENTS; SOUND SYSTEMS AND SOUND ELEMENTS FOR TELEVISIONS AND RADIOS COMPRISED OF SURROUND SOUND SYSTEMS, SOUND SYSTEMS COMPRISED REMOTE CONTROLS, AMPLIFIERS, LOUDSPEAKERS AND COMPONENTS THEREFOR, PERSONAL HEADPHONES FOR USE WITH SOUND TRANSMITTING SYSTEMS; AUDIO EQUIPMENT, NAMELY, MEDIA PLAYERS, PORTABLE MEDIA PLAYERS, DVD PLAYERS, PORTABLE DVD PLAYERS, CD PLAYERS, PORTABLE CD PLAYERS, MEDIA PLAYERS FOR AUTOMOBILES, DVD PLAYERS FOR AUTOMOBILES, CD PLAYERS FOR AUTOMOBILES, DIGITAL AUDIO PLAYERS, PORTABLE DIGITAL AUDIO PLAYERS, DIGITAL AUDIO PLAYERS FOR AUTOMOBILES; AUDIO SPEAKERS FOR HOME THEATER SYSTEMS; AUDIO SPEAKERS FOR COMPUTERS; AUDIO RECORDINGS FEATURING MUSIC; COMPUTER SOFTWARE FOR PROCESSING DIGITAL MUSIC FILES; DIGITAL PHOTO FRAMES FOR DISPLAYING DIGITAL PICTURES, VIDEO CLIPS AND MUSIC; DOWNLOADABLE MUSIC VIA THE INTERNET AND WIRELESS DEVICES; DOWNLOADABLE MP3 OR MP4 FILES, MP3 OR MP4 RECORDINGS AND DOWNLOADABLE PODCASTS FEATURING MUSIC, AUDIO BOOKS AND NEWS BROADCASTS; VIDEO RECORDINGS FEATURING MUSIC; MUSIC-COMPOSITION SOFTWARE; VISUAL RECORDINGS AND AUDIO VISUAL RECORDINGS FEATURING MUSIC; DOWNLOADABLE VISUAL RECORDINGS FEATURING MUSIC AND MUSICAL BASED ENTERTAINMENT; DOWNLOADABLE CELLULAR PHONE RINGTONES; APPARATUS FOR RECORDING, TRANSMISSION OR REPRODUCTION OF SOUND OR IMAGES (U.S. CLS. 21, 23, 26, 36 AND 38).

CLASS 25—CLOTHING

FOR CLOTHING, NAMELY, BLOUSES, DRESSES, BOTTOMS, COATS, FOUL WEATHER GEAR, GLOVES, HOSIERY, JACKETS, JEANS, LINGERIE, MITTENS, NECKTIES, NECKWEAR, NIGHTWEAR, PAJAMAS, PANTS, PULLOVERS, RAINWEAR, ROBES, SCARVES, SHIRTS, SHORTS, SKIRTS, SKORTS, SOCKS, SWEATSHIRTS, SWEATERS, SWIMWEAR, T-SHIRTS, TRACK SUITS, UNDERGARMENTS, VESTS, POLO SHIRTS, SWEAT PANTS, JERSEYS, BELTS; FOOTWEAR; HEADGEAR, NAMELY, CAPS, HATS, VISORS, SKULLCAPS, BEANIES (U.S. CLS. 22 AND 39).

CLASS 38—COMMUNICATION

FOR PROVIDING ONLINE ELECTRONIC BULLETIN BOARDS FOR TRANSMISSION OF MESSAGES AMONG COMPUTER USERS CONCERNING MEDIA, MUSIC, VIDEO, FILM, BOOK AND TELEVISION; STREAMING OF VIDEO CONTENT VIA A GLOBAL COMPUTER NETWORK; STREAMING OF AUDIO CONTENT VIA A GLOBAL COMPUTER NETWORK (U.S. CLS. 100, 101 AND 104).

CLASS 41—EDUCATION AND ENTERTAINMENT

FOR NIGHTCLUB SERVICES; DANCE CLUB SERVICES; PROVISION OF LIVE ENTERTAINMENT AND RECORDED ENTERTAINMENT, NAMELY, LIVE MUSICAL PERFORMANCES BY MUSICAL BANDS AND DJs; ENTERTAINMENT SERVICES, NAMELY, NON-DOWNLOADABLE RINGTONES, PRE-RECORDED MUSIC, VIDEO AND GRAPHICS PRESENTED TO MOBILE COMMUNICATIONS DEVICES VIA A GLOBAL COMPUTER NETWORK AND WIRELESS NETWORK; MUSIC STUDIOS, NAMELY, SOUND RECORDING STUDIOS; PUBLISHING SERVICES IN THE NATURE OF MUSIC PUBLISHING; MUSICAL ENTERTAINMENT IN THE NATURE OF LIVE VISUAL AND AUDIO PERFORMANCES BY MUSICAL GROUPS AND DJs; EXHIBITIONS, NAMELY, EXHIBITIONS CONCERNING MUSIC; PROVIDING ONLINE MUSIC SERVICES, NAMELY, PROVIDING NON-DOWNLOADABLE PRE-RECORDED MUSIC VIA GLOBAL COMPUTER NETWORK; ENTERTAINMENT SERVICES, NAMELY, PROVIDING A WEB SITE FEATURING MUSICAL PERFORMANCES, MUSICAL VIDEOS, RELATED FILM CLIPS, PHOTOGRAPHS, AND OTHER MULTIMEDIA ENTERTAINMENT MATERIALS, PROVIDING ON-LINE REVIEWS OF MUSIC PERFORMANCES, CONCERTS, MUSIC ALBUMS AND RECORDINGS AND MUSICAL ARTISTS, PROVIDING NONDOWNLOADABLE PRERECORDED MUSIC, INFORMATION IN THE FIELD OF MUSIC, AND COMMENTARY AND ARTICLES ABOUT MUSIC, ALL ON-LINE VIA A GLOBAL COMPUTER NETWORK; PROVIDING PODCASTS IN THE FIELD OF MUSIC, PROVIDING WEBCASTS IN THE FIELD OF MUSIC AND OTHER MULTIMEDIA ENTERTAINMENT MATERIALS (U.S. CLS. 100, 101 AND 107).

BENJAMIN OKEKE, EXAMINING ATTORNEY

SN 77-808,211, IDOYA LIMITED, LIMASSOL, CYPRUS, FILED 8-19-2009.

XXXBLACKBOOK.COM

THE MARK CONSISTS OF STANDARD CHARACTERS WITHOUT CLAIM TO ANY PARTICULAR FONT, STYLE, SIZE, OR COLOR.

CLASS 35—ADVERTISING AND BUSINESS

FOR PROVIDING AN ONLINE DIRECTORY INFORMATION SERVICE FEATURING INFORMATION, NAMELY, MEMBER PERSONAL INFORMATION, PROFILES, DIARIES, AND AUDIO AND VIDEO MATERIALS IN THE FIELD OF SOCIAL NETWORKING; ADVERTISING AND MARKETING SERVICES; NAMELY, PROMOTING THE GOODS AND SERVICES OF OTHERS BY PLACING ADVERTISEMENTS AND PROMOTIONAL DISPLAYS ON AN ELECTRONIC WEBSITE; DISSEMINATION OF ADVERTISING FOR OTHERS VIA WEBSITES AND ELECTRONIC MAIL; ELECTRONIC PUBLISHING SERVICES, NAMELY, PUBLICATION OF PUBLICITY TEXT, AUDIO, VIDEO AND GRAPHIC WORKS OF OTHERS ONLINE (U.S. CLS. 100, 101 AND 102).

FIRST USE 8-31-2007; IN COMMERCE 8-31-2007.

CLASS 38—COMMUNICATION

FOR CHAT ROOM SERVICES FOR SOCIAL NETWORKING; TELECOMMUNICATION SERVICES, NAMELY, TRANSMISSION OF WEBCASTS; PROVIDING ON-LINE CHAT ROOMS FOR TRANSMISSION OF MESSAGES AND PHOTOGRAPHS AMONG COMPUTER USERS INTERESTED IN MEETING OTHER PEOPLE CONCERNING PERSONAL RELATIONSHIP ISSUES; ELECTRONIC TRANSMISSION OF MESSAGES AND IMAGES RELATING TO DATING; PROVIDING EMAIL SERVICES, NAMELY, PROVIDING ACCESS TO EMAIL BOXES ON A DATING WEBSITE; ELECTRONIC TRANSMISSION OF MAIL AND USER-PROVIDED INFORMATION, PERSONAL PROFILES AND INFORMATION VIA THE INTERNET; INSTANT MESSAGING SERVICES VIA THE INTERNET; ELECTRONIC TRANSMISSION OF INFORMATION AND SOUND AND VIDEO CLIPS; PROVIDING ON-LINE FORUMS FOR TRANSMISSION OF MESSAGES AMONG COMPUTER USERS; CHAT ROOM SERVICES FOR SOCIAL NETWORKING; PROVIDING ON-LINE ELECTRONIC BULLETIN BOARDS FOR TRANSMISSION OF MESSAGES AMONG COMPUTER USERS CONCERNING PERSONAL RELATIONSHIP ISSUES (U.S. CLS. 100, 101 AND 104).

FIRST USE 8-31-2007; IN COMMERCE 8-31-2007.

CLASS 41—EDUCATION AND ENTERTAINMENT

FOR ENTERTAINMENT SERVICES, NAMELY, PROVIDING A WEB SITE FEATURING ADULT-THEMED VIDEOS; ELECTRONIC PUBLISHING SERVICES, NAMELY, PUBLICATION OF TEXT, AUDIO, VIDEO AND GRAPHIC WORKS OF OTHERS ONLINE FEATURING SEXUAL CONTENT; ENTERTAINMENT SERVICES, NAMELY, PROVIDING WEBCASTS IN THE FIELD OF SEXUAL RELATIONSHIPS (U.S. CLS. 100, 101 AND 107).

FIRST USE 8-31-2007; IN COMMERCE 8-31-2007.

CLASS 42—SCIENTIFIC AND COMPUTER SERVICES

FOR HOSTING ONLINE WEBSITES FOR OTHERS FOR ORGANIZING AND CONDUCTING ONLINE MEETINGS, GATHERINGS AND INTERACTIVE DISCUSSIONS (U.S. CLS. 100 AND 101).

FIRST USE 8-31-2007; IN COMMERCE 8-31-2007.

SN 77-795,144, SUMAJIN LTD., TANGLIN HALT IND EST, SINGAPORE, FILED 8-3-2009.

FLEX

THE MARK CONSISTS OF STANDARD CHARACTERS WITHOUT CLAIM TO ANY PARTICULAR FONT, STYLE, SIZE, OR COLOR.

CLASS 16—PAPER GOODS AND PRINTED MATTER

FOR COMICS (U.S. CLS. 2, 5, 22, 23, 29, 37, 38 AND 50). FIRST USE 6-1-2009; IN COMMERCE 6-1-2009.

CLASS 28—TOYS AND SPORTING GOODS

FOR ACTION FIGURES (U.S. CLS. 22, 23, 38 AND 50). FIRST USE 6-1-2009; IN COMMERCE 6-1-2009. GIANCARLO CASTRO, EXAMINING ATTORNEY

CLASS 45—PERSONAL AND LEGAL SERVICES

FOR ONLINE ADULT DATING; MATCHMAKING AND SOCIAL INTRODUCTION SERVICES PROVIDED OVER THE INTERNET (U.S. CLS. 100 AND 101).

FIRST USE 8-31-2007; IN COMMERCE 8-31-2007.
EVELYN BRADLEY, EXAMINING ATTORNEY

SN 77-815,373. RADLO FOODS, LLC., WATERTOWN, MA.
FILED 8-28-2009.

SN 77-810,081. KOLALOKA INDUSTRIES, LP, DALLAS, TX.
FILED 8-21-2009.

**DON'T THROW IT AWAY ...
FIX IT**

THE MARK CONSISTS OF STANDARD CHARACTERS WITHOUT CLAIM TO ANY PARTICULAR FONT, STYLE, SIZE, OR COLOR.

CLASS 1—CHEMICALS

FOR ADHESIVES FOR INDUSTRIAL USE; AND GLUES FOR USE IN THE AUTOMOTIVE INDUSTRY, AUTOMOTIVE REPAIR INDUSTRY, FOOTWEAR INDUSTRY, PLASTICS INDUSTRY, TOY INDUSTRY, AND FURNITURE INDUSTRY; PUTTY-LIKE EPOXY GLUE FOR USE IN THE AUTOMOTIVE INDUSTRY, AUTOMOTIVE REPAIR INDUSTRY, FOOTWEAR INDUSTRY, PLASTICS INDUSTRY, TOY INDUSTRY, FURNITURE INDUSTRY, CONSTRUCTION INDUSTRY, HOME APPLIANCE INDUSTRY, CERAMICS INDUSTRY, AND PORCELAIN INDUSTRY (U.S. CLS. 1, 5, 6, 10, 26 AND 46).

CLASS 3—COSMETICS AND CLEANING PREPARATIONS

FOR ADHESIVES AND GLUES FOR COSMETIC USE; ADHESIVES AND GLUES FOR USE ON ARTIFICIAL NAILS; ADHESIVES AND GLUES FOR ADHERING ARTIFICIAL NAILS TO NATURAL NAILS; NAIL GROOMING PRODUCTS, NAMELY, ADHESIVES AND GLUES FOR USE ON NATURAL NAILS AND ADHESIVES AND GLUES FOR REPAIRING NATURAL NAILS (U.S. CLS. 1, 4, 6, 50, 51 AND 52).

CLASS 16—PAPER GOODS AND PRINTED MATTER

FOR ADHESIVES AND GLUES FOR STATIONERY AND HOUSEHOLD PURPOSES, NAMELY, FOR USE WITH OTHER PAPER PRODUCTS; ADHESIVES AND GLUES FOR HOUSEHOLD USE (U.S. CLS. 2, 5, 22, 23, 29, 37, 38 AND 50).

CLASS 17—RUBBER GOODS

FOR EPOXY PUTTY GLUE FOR USE IN THE AUTOMOTIVE INDUSTRY, AUTOMOTIVE REPAIR INDUSTRY, FOOTWEAR INDUSTRY, PLASTICS INDUSTRY, TOY INDUSTRY, FURNITURE INDUSTRY, CONSTRUCTION INDUSTRY, HOME APPLIANCE INDUSTRY, CERAMICS INDUSTRY, AND PORCELAIN INDUSTRY (U.S. CLS. 1, 5, 12, 13, 35 AND 50).

BILL DAWE, EXAMINING ATTORNEY

BORN FREE

THE MARK CONSISTS OF STANDARD CHARACTERS WITHOUT CLAIM TO ANY PARTICULAR FONT, STYLE, SIZE, OR COLOR.

OWNER OF U.S. REG. NO. 2,741,175.

CLASS 29—MEATS AND PROCESSED FOODS

FOR MEAT; POULTRY; FROZEN FOODS, NAMELY, OMELETS; BREAKFAST PRODUCTS, NAMELY, OMELETS; EGG SUBSTITUTES; DAIRY PRODUCTS EXCLUDING ICE CREAM, ICE MILK AND FROZEN YOGURT (U.S. CL. 46).

CLASS 30—STAPLE FOODS

FOR DAIRY PRODUCTS, NAMELY, ICE CREAM, ICE MILK AND FROZEN YOGURT; FROZEN FOODS, NAMELY, SANDWICHES CONSISTING PRIMARILY OF EGG PRODUCT, TURKEY SAUSAGE, TURKEY BACON, CHEESE, VEGETABLES OR POTATOES; BREAKFAST PRODUCTS, NAMELY, SANDWICHES CONSISTING PRIMARILY OF EGG PRODUCT, TURKEY SAUSAGE, TURKEY BACON, CHEESE, VEGETABLES OR POTATOES (U.S. CL. 46).

CLASS 32—LIGHT BEVERAGES

FOR NON-ALCOHOLIC BEVERAGES, NAMELY, FRUIT JUICES AND FRUIT BEVERAGES; WATER (U.S. CLS. 45, 46 AND 48).

BRENDAN MCCAULEY, EXAMINING ATTORNEY

SN 77-815,393. RADLO FOODS, LLC., WATERTOWN, MA.
FILED 8-28-2009.



OWNER OF U.S. REG. NO. 2,741,175.

THE MARK CONSISTS OF THE WORDS "BORN FREE" BETWEEN TWO HORIZONTAL LINES; A FEATHER OVERLAPS THE TOP HORIZONTAL LINE ABOVE THE "N" IN THE WORD "BORN".

CLASS 29—MEATS AND PROCESSED FOODS

FOR MEAT; POULTRY; FROZEN FOODS, NAMELY, OMELETS; BREAKFAST PRODUCTS, NAMELY, OMELETS; EGG SUBSTITUTES; DAIRY PRODUCTS EXCLUDING ICE CREAM, ICE MILK AND FROZEN YOGURT (U.S. CL. 46).

CLASS 30—STAPLE FOODS

FOR DAIRY PRODUCTS, NAMELY, ICE CREAM, ICE MILK AND FROZEN YOGURT; BREAKFAST PRODUCTS, NAMELY, SANDWICHES CONSISTING PRIMARILY OF EGG PRODUCT, TURKEY SAUSAGE, TURKEY BACON, CHEESE, VEGETABLES OR POTATOES; FROZEN FOODS, NAMELY, SANDWICHES CONSISTING PRIMARILY OF EGG PRODUCT, TURKEY SAUSAGE, TURKEY BACON, CHEESE, VEGETABLES OR POTATOES (U.S. CL. 46).

SN 77-833,538. SAMSUNG ELECTRONICS CO., LTD., SUWON-SI, GYEONGGI-DO, REPUBLIC OF KOREA, FILED 9-23-2009.

ALLSHARE

THE MARK CONSISTS OF STANDARD CHARACTERS WITHOUT CLAIM TO ANY PARTICULAR FONT, STYLE, SIZE, OR COLOR.

PRIORITY CLAIMED UNDER SEC. 44(D) ON REPUBLIC OF KOREA APPLICATION NO. 2009-0046770, FILED 9-23-2009, REG. NO. 0841760, DATED 11-3-2010, EXPIRES 11-3-2020.

CLASS 32—LIGHT BEVERAGES

FOR NON-ALCOHOLIC BEVERAGES, NAMELY, FRUIT JUICES AND FRUIT BEVERAGES; WATER (U.S. CLS. 45, 46 AND 48).

BRENDAN MCCAULEY, EXAMINING ATTORNEY

CLASS 7—MACHINERY

FOR ELECTRIC WASHING MACHINES FOR CLOTHES; ELECTRIC VACUUM CLEANERS FOR HOUSEHOLD PURPOSES; ELECTRIC VACUUM CLEANERS; ELECTRIC MIXERS FOR HOUSEHOLD PURPOSES; AUTOMATIC DISHWASHERS; VACUUM CLEANER BAGS; ROBOTIC VACUUM CLEANERS; INDUSTRIAL ROBOTS (U.S. CLS. 13, 19, 21, 23, 31, 34 AND 35).

SN 77-829,419. THE GREENHORIZONS GROUP OF FARMS LTD., MOUNT HOPE, ONTARIO, CANADA, FILED 9-18-2009.

CLASS 9—ELECTRICAL AND SCIENTIFIC APPARATUS

FOR TELEVISION RECEIVERS; COMPUTERS; COMPUTER PRINTERS; ELECTRONIC PHOTOCOPIERS; FACSIMILE MACHINES; COMPUTER MONITORS; HARD DISC DRIVES; OPTICAL DISC DRIVES; COMPUTER MEMORY CARDS; NOTEBOOK COMPUTERS; PERSONAL DIGITAL ASSISTANTS; SEMICONDUCTORS; MOBILE PHONES; DVD PLAYERS; MP3 PLAYERS; CAMCORDERS; DIGITAL CAMERAS; COMPUTER MICE (U.S. CLS. 21, 23, 26, 36 AND 38).

BIGYELLOWBAG

CLASS 11—ENVIRONMENTAL CONTROL APPARATUS

FOR ELECTRIC REFRIGERATORS; WATER PURIFIERS FOR HOUSEHOLD PURPOSES; ICE-COOLING REFRIGERATORS FOR HOUSEHOLD PURPOSES; GAS RANGES; AIR CONDITIONERS; VENTILATORS FOR LIVING ROOM AIR CIRCULATION; HUMIDIFIERS; MICROWAVE OVENS; AIR PURIFIERS FOR HOUSEHOLD PURPOSES (U.S. CLS. 13, 21, 23, 31 AND 34).

ELLEN PERKINS, EXAMINING ATTORNEY

THE MARK CONSISTS OF STANDARD CHARACTERS WITHOUT CLAIM TO ANY PARTICULAR FONT, STYLE, SIZE, OR COLOR.

PRIORITY CLAIMED UNDER SEC. 44(D) ON CANADA APPLICATION NO. 1433326, FILED 4-2-2009, REG. NO. TMA785,701, DATED 12-21-2010, EXPIRES 12-21-2025.

CLASS 1—CHEMICALS

FOR LAWN AND GARDEN FERTILIZERS (U.S. CLS. 1, 5, 6, 10, 26 AND 46).

SN 77-838,537. JAKOB HATTELAND LOGISTICS AS, VATS, NORWAY, FILED 9-30-2009.

CLASS 31—NATURAL AGRICULTURAL PRODUCTS

FOR TOP SOIL; GRASS AND LAWN SEED; TURF GRASS SOD; MULCH (U.S. CLS. 1 AND 46).

OWNER OF NORWAY REG. NO. 207636, DATED 3-29-2001, EXPIRES 3-29-2021.

THE COLOR(S) BLUE, TEAL AND WHITE IS/ARE CLAIMED AS A FEATURE OF THE MARK.

THE MARK CONSISTS OF THE PHRASE "AUTOSTORE" AND A DESIGN OF 8 RECTANGLES. FOUR RECTANGLES ARE IN A ROW IN THE FOLLOWING ORDER: THE LETTER "A" IN WHITE IN A TEAL RECTANGLE, THE LETTER "U" IN WHITE IN A TEAL RECTANGLE, THE

CLASS 35—ADVERTISING AND BUSINESS

FOR RETAIL STORE SERVICES FEATURING LAWN AND GARDEN SUPPLIES (U.S. CLS. 100, 101 AND 102).

CLASS 44—MEDICAL, BEAUTY AND AGRICULTURAL SERVICES

FOR PROVIDING INFORMATION AND ADVICE IN THE FIELD OF LAWN AND GARDEN SUPPLIES (U.S. CLS. 100 AND 101).

DAWN HAN, EXAMINING ATTORNEY

LETTER "T" IN WHITE IN A TEAL RECTANGLE, THE LETTER "O" IN WHITE IN A RECTANGLE IN SHADES OF WHITE, BLUE AND TEAL, THE LETTER "S" IN WHITE IN A TEAL RECTANGLE IS BELOW THE "U". THE LETTER "T" IN WHITE IN A TEAL RECTANGLE IS BELOW THE "T". THE LETTER "O" IS SHARED BY BOTH WORDS "AUTO" AND "STORE". ON THE SAME LINE AS THE "S" AND "T" AND NEXT TO THE LETTER "O", IS A WHITE "R" IN A TEAL RECTANGLE, AND NEXT TO THE "R" IS A WHITE "E" IN A TEAL RECTANGLE.

CLASS 7—MACHINERY

FOR MACHINES FOR PACKAGING IN THE WAREHOUSING OF COMPUTERS, ELECTRONIC DEVICES, TELECOMMUNICATIONS DEVICES, FOOD AND CLOTHING; AUTOMATED CONVEYING MACHINES, NAMELY, CONVEYORS MACHINES, CONVEYOR BELTS AND ROLLER CONVEYORS FOR CONVEYING GOODS FOR STORAGE AND RETRIEVAL, FOR USE IN WAREHOUSING OF COMPUTERS, ELECTRONIC DEVICES, TELECOMMUNICATION DEVICES, FOODS AND CLOTHING; MOTORS AND ENGINES FOR MACHINES; ELECTRONICALLY CONTROLLED MACHINES, NAMELY, COMPUTER CONTROLLED AUTOMATED STORAGE AND RETRIEVAL MACHINES FOR USE IN THE MANAGEMENT AND OPERATION OF WAREHOUSING OF COMPUTERS, ELECTRONIC DEVICES, TELECOMMUNICATION DEVICES SUCH AS MOBILE PHONES AND TELEPHONES, FOODS AND CLOTHING (U.S. CLS. 13, 19, 21, 23, 31, 34 AND 35).

CLASS 9—ELECTRICAL AND SCIENTIFIC APPARATUS

FOR ELECTRONIC DEVICES, NAMELY, PORTABLE CD PLAYERS, CAMERAS, VIDEO CAMERAS; TELECOMMUNICATION DEVICES, NAMELY, MOBILE PHONES AND TELEPHONES; APPARATUS AND INSTRUMENTS, NAMELY, MULTIMETERS FOR INVENTORY MANAGEMENT AND WAREHOUSING SERVICES IN THE FIELDS OF COMPUTERS, ELECTRONIC DEVICES, TELECOMMUNICATION DEVICES, FOOD AND CLOTHING; COMPUTER FIRMWARE AND COMPUTER PERIPHERALS FOR INVENTORY MANAGEMENT AND WAREHOUSING SERVICES IN THE FIELDS OF COMPUTERS, ELECTRONIC DEVICES, TELECOMMUNICATION DEVICES, FOOD AND CLOTHING; COMPUTER FIRMWARE AND COMPUTER PERIPHERALS FOR INVENTORY MANAGEMENT AND WAREHOUSING MONITORING IN THE FIELDS OF COMPUTERS, ELECTRONIC DEVICES, TELECOMMUNICATION DEVICES, FOOD AND CLOTHING (U.S. CLS. 21, 23, 26, 36 AND 38).

CLASS 37—CONSTRUCTION AND REPAIR

FOR INSTALLATION, MAINTENANCE AND REPAIR OF AUTOMATED STORAGE AND RETRIEVAL MACHINES FOR USE IN THE WAREHOUSING OF COMPUTERS, ELECTRONIC DEVICES, TELECOMMUNICATION DEVICES, FOOD AND CLOTHING; INSTALLATION, MAINTENANCE AND REPAIR OF MACHINES FOR PACKAGING, TRANSPORT AND STORING OF COMPUTERS, ELECTRONIC DEVICES, TELECOMMUNICATION DEVICES, FOOD AND CLOTHING; INSTALLATION, MAINTENANCE AND REPAIR OF COMPUTER HARDWARE SYSTEMS FOR PACKAGING, TRANSPORT AND STORING OF COMPUTERS, ELECTRONIC DEVICES, TELECOMMUNICATION DEVICES, FOOD AND CLOTHING; MAINTENANCE OF COMPUTER HARDWARE SYSTEMS FOR INVENTORY CONTROL AND WAREHOUSE STORAGE (U.S. CLS. 100, 103 AND 106).

CLASS 42—SCIENTIFIC AND COMPUTER SERVICES

FOR DESIGNING AND UPDATING, FOR OTHERS, COMPUTER PROGRAMS AND SOFTWARE IN THE FIELD OF INVENTORY MANAGEMENT AND WAREHOUSING SERVICES IN THE FIELDS OF COMPUTERS, ELECTRONIC DEVICES, TELECOMMUNICATIONS DEVICES, FOOD AND CLOTHING; RENTAL OF COMPUTERS; RENTAL OF COMPUTER PROGRAMS AND SOFTWARE IN THE FIELD OF INVENTORY MANAGEMENT AND WAREHOUSING SERVICES IN THE FIELDS OF COMPUTERS, ELECTRONIC DEVICES, TELECOMMUNICATIONS DEVICES, FOOD AND CLOTHING; MAINTENANCE OF COMPUTER PROGRAMS AND SOFTWARE IN THE FIELD OF INVENTORY CONTROL AND WAREHOUSE STORAGE; INSTALLATION, MAINTENANCE AND REPAIR OF SOFTWARE FOR COMPUTER SYSTEMS FOR PACKAGING, TRANSPORT AND STORING OF COMPUTERS, ELECTRONIC DEVICES, TELECOMMUNICATION DEVICES, FOOD AND CLOTHING; MAINTENANCE OF SOFTWARE FOR COMPUTER SYSTEMS FOR INVENTORY CONTROL AND WAREHOUSE STORAGE (U.S. CLS. 100 AND 101).

KIM SAITO, EXAMINING ATTORNEY

SN 77-841,580. SONALYSTS, INC., WATERFORD, CT. FILED 10-5-2009.

SONALYSTS

THE MARK CONSISTS OF STANDARD CHARACTERS WITHOUT CLAIM TO ANY PARTICULAR FONT, STYLE, SIZE, OR COLOR.

OWNER OF U.S. REG. NOS. 1,731,744 AND 3,081,759.

CLASS 41—EDUCATION AND ENTERTAINMENT

FOR AUDIO RECORDING AND PRODUCTION, VIDEOTAPE FILM PRODUCTION, AND TRAINING IN USE AND OPERATION OF NAVAL SENSOR AND COMBAT CONTROL EQUIPMENT AND NUCLEAR POWER PLANT CONTROL EQUIPMENT (U.S. CLS. 100, 101 AND 107).

FIRST USE 11-30-1973; IN COMMERCE 11-30-1973.

CLASS 42—SCIENTIFIC AND COMPUTER SERVICES

FOR ENGINEERING SERVICES, COMPUTER SOFTWARE DESIGN AND DEVELOPMENT, AND TECHNOLOGICAL CONSULTATION AND RESEARCH IN THE FIELD OF ACOUSTICS AND ELECTRONICS FOR SCIENTIFIC PURPOSES ALL FOR NAVAL AND OTHER DEFENSE FORCES AND ASSOCIATED INDUSTRIES (U.S. CLS. 100 AND 101).

FIRST USE 11-30-1973; IN COMMERCE 11-30-1973.
STEVEN JACKSON, EXAMINING ATTORNEY

SN 77-842,555. BANGOURA, SAYDOU, BERLIN, FED REP GERMANY, AND MÜNCH, NINA, BERLIN, FED REP GERMANY, FILED 10-6-2009.

TRIBASPACE

THE MARK CONSISTS OF STANDARD CHARACTERS WITHOUT CLAIM TO ANY PARTICULAR FONT, STYLE, SIZE, OR COLOR.

PRIORITY CLAIMED UNDER SEC. 44(D) ON FED REP GERMANY APPLICATION NO. 302009022058, FILED 4-14-2009, REG. NO. 301009022058, DATED 7-13-2009, EXPIRES 4-30-2019.

CLASS 9—ELECTRICAL AND SCIENTIFIC APPARATUS

FOR SOFTWARE FOR THE ADMINISTRATION OF DATABASES IN THE FIELDS OF BUSINESS AND PRIVATE NETWORKS AS WELL AS ESTABLISHING AND ARRANGING BUSINESS AND PRIVATE CONTACTS; PROGRAMME-TECHNICAL INSTRUCTIONS, HARDWARE AND DOCUMENTATION IN ELECTRONIC FORMAT FOR PURPOSES OF BUSINESS AND PRIVATE NETWORKS, EXCEPT FOR SOFTWARE FOR FINANCIAL SERVICES, CUSTOMER RELATIONSHIP MANAGEMENT AND SUPPLY CHAIN MANAGEMENT, NAMELY, OPERATING AND USER INSTRUCTIONS FOR COMPUTERS AND COMPUTER SOFTWARE RECORDED ON COMPUTER MEDIA; SOFTWARE FOR UPLOADING, SENDING, DISPLAYING, MARKING, BLOGGING AND SHARING ELECTRONIC MEDIA OR INFORMATION VIA THE INTERNET OR OTHER COMMUNICATION NETWORKS; ELECTRONIC DATABASES IN THE FIELDS OF FASHION, FILM, MEDIA, MUSIC AND ART RECORDED ON COMPUTER MEDIA (U.S. CLS. 21, 23, 26, 36 AND 38).

CLASS 16—PAPER GOODS AND PRINTED MATTER

FOR PAPER, CARDBOARD AND GOODS MADE FROM THESE MATERIALS, NAMELY, ADVERTISING MATERIAL AS GOODS IN TRADE, NAMELY, ADVERTISING PAMPHLETS, ADVERTISING SIGNS OF PAPER OR CARDBOARD AND PRINTED ADVERTISING BOARDS OF PAPER OR CARDBOARD; PRINTED MATTER, NAMELY, MAGAZINES IN THE FIELDS OF FASHION, BEAUTY, STYLE, INTERIOR DESIGN, GRAPHIC DESIGN, SOCIAL MEDIA, SOCIAL NETWORKING, LIFESTYLE, ARTS AND CULTURE, AND INFORMATION TECHNOLOGY; PRINTED INSTRUCTIONAL AND TEACHING MATERIALS IN THE FIELDS OF FASHION, SOCIAL MEDIA, SOCIAL NETWORKING, BUSINESS TO BUSINESS PLATFORMS FEATURING ONLINE AND INTERACTIVE SHOPPING MALLS AND SHOWROOMS, AND INFORMATION TECHNOLOGY (U.S. CLS. 2, 5, 22, 23, 29, 37, 38 AND 50).

CLASS 35—ADVERTISING AND BUSINESS

FOR ADVERTISING, BUSINESS MANAGEMENT, BUSINESS ADMINISTRATION; PROVIDING OFFICE FUNCTIONS; PUBLIC RELATIONS; ORGANISING AND ARRANGING OF EXHIBITIONS AND TRADE FAIRS FOR COMMERCIAL OR ADVERTISING PURPOSES; ADVERTISING, PARTICULARLY INITIATING AND ARRANGING BUSINESS CONTACTS, NAMELY, BUSINESS NETWORKING; DISTRIBUTION AND DISSEMINATION OF ADVERTISING MATERIALS, NAMELY, PRESENTING AND DISTRIBUTING GOODS AND SAMPLES FOR ADVERTISING PURPOSES, ALSO ONLINE VIA THE INTERNET; CONDUCTING OF PUBLIC SALES AND AUCTIONS ON THE INTERNET; ONLINE ADVERTISING ON A COMPUTER NETWORK; SPONSORING, NAMELY, ADVERTISING SERVICES; PROVISION AND RENTAL OF ADVERTISING SPACE ON THE INTERNET; ADVERTISING ON THE INTER-

NET FOR THIRD PARTIES; ADVERTISING AND SALES PROMOTION THROUGH WORLDWIDE COMMUNICATION NETWORKS TO FACILITATE THE SALE OF GOODS AND SERVICES OF THIRD PARTIES; INFO-MEDIARY SERVICES, NAMELY, FACILITATING TRANSACTIONS BETWEEN BUYERS AND SELLERS THROUGH PROVIDING BUYERS WITH INFORMATION ABOUT SELLERS, GOODS AND/OR SERVICES AND PROVIDING EVALUATIVE FEEDBACK AND INFORMATION ON THE RELIABILITY OF PURCHASERS AND SELLERS, DELIVERY TIMES AND GENERAL TRADING SERVICES IN CONNECTION THEREWITH; ARRANGING ONLINE MARKETPLACES FOR SELLERS AND BUYERS OF GOODS AND SERVICES OF OTHER ONLINE PROVIDERS; ADVERTISING BY MEANS OF A SEARCHABLE ONLINE ADVERTISING GUIDE FEATURING THE GOODS AND SERVICES OF OTHER ONLINE VENDORS ON THE INTERNET; MEASURES WITHIN THE CONTEXT OF CUSTOMER LOYALTY AND SERVICES OF CUSTOMER CLUBS FOR BUSINESS, SALES PROMOTION AND ADVERTISING PURPOSES, NAMELY, PROVIDING ONLINE BUSINESS NEWS FOR CUSTOMERS; SALES PROMOTION FOR GOODS AND SERVICES OF THIRD PARTIES; PROVIDING AN ONLINE AND INTERACTIVE INFRASTRUCTURE FOR WHOLESALE AND RETAIL SERVICES, NAMELY, OPERATING ONLINE MARKETPLACES FOR SELLERS OF GOODS AND/OR SERVICES, PROMOTING THE GOODS AND SERVICES OF OTHERS BY MEANS OF OPERATING AN ON-LINE AND INTERACTIVE SHOPPING MALL AND SHOWROOMS WITH LINKS TO THE RETAIL WEB SITES OF OTHERS, ON-LINE WHOLESALE AND RETAIL STORE SERVICES IN THE FIELDS OF FASHION, BEAUTY, STYLE, INTERIOR DESIGN, GRAPHIC DESIGN, SOCIAL MEDIA, SOCIAL NETWORKING, LIFESTYLE, ARTS AND CULTURE, AND INFORMATION TECHNOLOGY FEATURING CLOTHING, BEAUTY CARE PRODUCTS, HOME FURNISHINGS, FABRICS, ART AND INFORMATION TECHNOLOGY PRODUCTS; TRADE SERVICES ON THE INTERNET, NAMELY, PROCURING OF CONTRACTS FOR THE PURCHASE AND SALE OF GOODS AND SERVICES ON THE INTERNET; ADVERTISING BY MEANS OF AN ONLINE DIRECTORY INFORMATION SERVICE FOR INFORMATION REGARDING COMPANIES, ORGANIZATIONS SPECIAL INTEREST GROUPS AND PROJECT GROUPS PARTICULARLY IN THE FIELD OF THE FASHION INDUSTRY; GENERAL BUSINESS MERCHANDISING SERVICES, NAMELY, MARKETING; SALES PROMOTION; PROVIDING AN ONLINE DIRECTORY INFORMATION SERVICE FEATURING INFORMATION REGARDING COMPANIES AND THEIR LOCATIONS; BUSINESS ORGANIZATION AND ADMINISTRATION CONSULTANCY IN THE FIELDS OF THE USE, APPLICATION AND MAINTENANCE OF SOFTWARE PROGRAMMES OR DATA PROCESSING INFORMATION TECHNOLOGIES; COMPILING OF INFORMATION INTO COMPUTER DATABASES; BUSINESS ADMINISTRATION CONSULTANCY ALSO VIA THE INTERNET; BUSINESS CONSULTING IN THE NATURE OF PROCURING CONTRACTS FOR THIRD PARTIES FOR THE PURCHASE AND SALE OF GOODS VIA THE INTERNET, PROVISION OF ONLINE CONSULTING IN THE FIELD OF BUSINESS VIA THE INTERNET; ARRANGING OF BUYING AND SELLING CONTRACTS FOR THIRD PARTIES OF APPLICATIONS IN THE FIELDS OF SOFTWARE PROGRAMS, DATA PROCESSING INFORMATION TECHNOLOGIES AND MAINTENANCE SERVICES FOR SOFTWARE PROGRAMS AND DATA PROCESSING INFORMATION TECHNOLOGIES; ON-LINE RETAIL STORE SERVICES FEATURING A WIDE VARIETY OF CONSUMER GOODS OF OTHERS; COMPILATION AND PROVISION OF TRADE AND BUSINESS PRICE AND STATISTICAL, QUANTITATIVE AND QUALITATIVE INFORMATION RELATING TO THE SALE AND RESALE OF GOODS VIA A GLOBAL COMPUTER NETWORK (U.S. CLS. 100, 101 AND 102).

CLASS 38—COMMUNICATION

FOR PROVIDING ON-LINE CHAT ROOMS AND ELECTRONIC BULLETIN BOARDS FOR THE TRANSMISSION OF MESSAGES AMONG USERS IN THE FIELDS OF FASHION, BEAUTY, STYLE, INTERIOR DESIGN, GRAPHIC DESIGN, SOCIAL MEDIA, SOCIAL NETWORKING, LIFESTYLE, ARTS AND CULTURE, AND INFORMATION TECHNOLOGY; PROVIDING AN INTERACTIVE ONLINE FORUM FOR TRANSMISSION OF NEWS BETWEEN COMPUTER USERS WITH RESPECT TO THE TRADE AND SALE OF GOODS AND SERVICES THROUGH A WORLDWIDE COMMUNICATION NETWORK; ELECTRONIC COMMUNICATION, NAMELY, TRANSMISSION OF NEWS, INFORMATION, IMAGES AND TEXTS OF ALL KINDS; PROVIDING ONLINE DISCUSSION FORUMS FOR THE TRANSMISSION OF MESSAGES AMONG REGISTERED COMPUTER USERS TO COMMUNICATE NEWS CONCERNING COMPANIES, ORGANISATIONS, SPECIAL INTEREST GROUPS AND PROJECT GROUPS IN THE FIELDS OF FASHION, BEAUTY, STYLE, INTERIOR DESIGN, GRAPHIC DESIGN, SOCIAL MEDIA, SOCIAL NETWORKING, LIFESTYLE, ARTS AND CULTURE, AND INFORMATION TECHNOLOGY; ELECTRONIC EXCHANGE OF NEWS AND INFORMATION DATA STORED IN DATABASES ACCESSIBLE VIA TELECOMMUNICATION NETWORKS IN THE FIELDS OF FASHION, BEAUTY, STYLE, INTERIOR DESIGN, GRAPHIC DESIGN, SOCIAL MEDIA, SOCIAL NETWORKING, LIFESTYLE, ARTS AND CULTURE, AND INFORMATION TECHNOLOGY (U.S. CLS. 100, 101 AND 104).

CLASS 39—TRANSPORTATION AND STORAGE

FOR PROVIDING ELECTRONIC STORAGE OF FILES, DOCUMENTS, INFORMATION, IMAGES AND DATA (U.S. CLS. 100 AND 105).

CLASS 41—EDUCATION AND ENTERTAINMENT

FOR EDUCATION SERVICES, NAMELY, PROVIDING CLASSES, SEMINARS AND WORKSHOPS IN THE FIELDS OF FASHION, SOCIAL MEDIA, SOCIAL NETWORKING, BUSINESS TO BUSINESS PLATFORMS FEATURING ONLINE AND INTERACTIVE SHOPPING MALLS AND SHOWROOMS, AND INFORMATION TECHNOLOGY; PROVIDING TRAINING SERVICES IN THE FIELDS OF FASHION, SOCIAL MEDIA, SOCIAL NETWORKING, BUSINESS TO BUSINESS PLATFORMS FEATURING ONLINE AND INTERACTIVE SHOPPING MALLS AND SHOWROOMS, AND INFORMATION TECHNOLOGY; ORGANIZING COMMUNITY SPORTING AND CULTURAL EVENTS; PROVIDING TEMPORARY USE OF NON-DOWNLOADABLE INTERACTIVE GAMES; PROVIDING ONLINE COMPUTER AND VIDEO GAMES; ONLINE PUBLICATION OF PRINTED INFORMATION AND REPORTS IN THE NATURE OF MAGAZINES AND REVIEWS ON PERSONS, COMPANIES AND THEIR LOCATIONS IN THE FIELDS OF FASHION, BEAUTY, STYLE, INTERIOR DESIGN, GRAPHIC DESIGN, SOCIAL MEDIA, SOCIAL NETWORKING, LIFESTYLE, ARTS AND CULTURE AND INFORMATION TECHNOLOGY; PUBLISHING SERVICES, NAMELY, PUBLISHING OF BOOKS, REVIEWS, MAGAZINES AND TREND REPORTS IN THE FIELDS OF FASHION, BEAUTY, STYLE, INTERIOR DESIGN, GRAPHIC DESIGN, SOCIAL MEDIA, SOCIAL NETWORKING, LIFESTYLE, ARTS AND CULTURE, AND INFORMATION TECHNOLOGY; PUBLISHING OF BOOKS AND MAGAZINES FOR CULTURAL OR ENTERTAINMENT PURPOSES; INFORMATION IN THE FIELDS OF POPULAR CULTURE AND ENTERTAINMENT; PUBLICATION OF ONLINE JOURNALS, NAMELY, BLOGS FEATURING FASHION, BEAUTY, STYLE, INTERIOR DESIGN, GRAPHIC DESIGN, SOCIAL MEDIA, SOCIAL NETWORKING, LIFESTYLE, ARTS AND CULTURE, AND INFORMATION TECHNOLOGY; WRITING OF TEXTS FOR AN ONLINE DIRECTORY INFORMATION SERVICE FEATURING INFORMATION CONCERNING ACADEMIC LIFE, POPULARLY INTERESTING TOPICS, ADS, VIRTUAL COMMUNITIES, SOCIAL NETWORKS, EXCHANGING OF PICTURES AND TRANSMISSION OF PICTURES; INDUSTRIAL ANALYSIS AND RESEARCH SERVICES, NAMELY, PROVIDING USER STATISTICS,

TRENDS STATISTICS AND TREND REPORTS IN THE FIELDS OF ARTS AND POPULAR CULTURE AND SOCIAL MEDIA IN THE NATURE OF ON-LINE JOURNALS IN THE NATURE OF BLOGS (U.S. CLS. 100, 101 AND 107).

CLASS 42—SCIENTIFIC AND COMPUTER SERVICES

FOR INDUSTRIAL ANALYSIS AND RESEARCH SERVICES, NAMELY, PROVIDING USER STATISTICS, TRENDS STATISTICS AND TREND REPORTS IN THE FIELDS OF INTERIOR DESIGN, GRAPHIC DESIGN AND INFORMATION TECHNOLOGY; DESIGNING AND DEVELOPMENT OF COMPUTER HARDWARE AND SOFTWARE; UPDATING INTERNET WEBSITES FOR OTHERS; CONSULTANCY REGARDING THE DESIGN OF HOMEPAGES AND INTERNET SITES; PROVIDING SEARCH ENGINES FOR OBTAINING DATA ON A GLOBAL COMPUTER NETWORK; DESIGNING AND DEVELOPING HOMEPAGES AND INTERNET SITES FOR THIRD PARTIES; COMPUTER SOFTWARE RENTAL AND DEVELOPMENT FOR THE INFORMATION TECHNOLOGY INDUSTRY, PARTICULARLY PROGRAMMES FOR DATA PROCESSING IN THE FIELDS OF BUSINESS AND PRIVATE NETWORKS AS WELL AS FOR ESTABLISHING AND ARRANGING BUSINESS AND PRIVATE CONTACTS; DEVELOPING OF COMPUTER SOFTWARE FOR THE INFORMATION TECHNOLOGY INDUSTRY; INSTALLATION AND MAINTENANCE OF DATA PROCESSING COMPUTER SOFTWARE IN THE FIELDS OF COMMERCIAL AND PRIVATE NETWORKS AS WELL AS FOR ESTABLISHING AND ARRANGING BUSINESS AND PRIVATE CONTACTS; TECHNICAL ADVICE AND TECHNICAL SUPPORT, NAMELY, TROUBLESHOOTING OF COMPUTER SOFTWARE PROBLEMS REGARDING THE USE, APPLICATION AND MAINTENANCE OF DATA PROCESSING SOFTWARE IN THE FIELDS OF COMMERCIAL AND PRIVATE NETWORKS AS WELL AS FOR ESTABLISHING AND ARRANGING BUSINESS AND PRIVATE CONTACTS; MAINTENANCE OF COMPUTER SOFTWARE FOR DATA PROCESSING IN THE FIELDS OF COMMERCIAL AND PRIVATE NETWORKS AS WELL AS FOR ESTABLISHING AND ARRANGING BUSINESS AND PRIVATE CONTACTS; PROVIDING TEMPORARY USE OF NON-DOWNLOADABLE COMPUTER SOFTWARE FOR SHIPMENT PROCESSING OVER COMPUTER NETWORKS, INTRANETS AND THE INTERNET; APPLICATION SERVICE PROVIDER FEATURING SOFTWARE FOR PROVIDING AN ON-LINE DATABASE IN THE FIELD OF TRANSACTION PROCESSING TO UPLOAD TRANSACTIONAL DATA, PROVIDE STATISTICAL ANALYSIS, AND PRODUCE NOTIFICATIONS AND REPORTS; CREATING AND MAINTAINING WEBLOGS FOR OTHERS (U.S. CLS. 100 AND 101).

CLASS 45—PERSONAL AND LEGAL SERVICES

FOR INITIATING ACQUAINTANCES AND SOCIAL NETWORKING THROUGH ARRANGING OF PRIVATE CONTACTS, NAMELY, ONLINE SOCIAL NETWORKING SERVICES; LICENSING OF INTELLECTUAL AND INDUSTRIAL PROPERTY RIGHTS; INITIATING AND ARRANGING PRIVATE CONTACTS, NAMELY, MATCHMAKING SERVICES; INVESTIGATIONS AND RESEARCH IN DATABASES ON PERSONS, NAMELY, PERSONAL BACKGROUND INVESTIGATIONS; LICENSING OF TECHNICAL SOLUTIONS, NAMELY, COMPUTER SOFTWARE FOR THE INFORMATION TECHNOLOGY INDUSTRY, PARTICULARLY PROGRAMMES FOR DATA PROCESSING IN THE FIELDS OF COMMERCIAL AND PRIVATE NETWORKS AND FOR ESTABLISHING AND ARRANGING BUSINESS AND PRIVATE CONTACTS; INDUSTRIAL ANALYSIS AND RESEARCH SERVICES, NAMELY, PROVIDING USER STATISTICS, TRENDS STATISTICS AND TREND REPORTS IN THE FIELDS OF FASHION, FASHION STYLE, SOCIAL NETWORKING, LIFESTYLE AND SOCIAL MEDIA IN THE NATURE OF ON-LINE SOCIAL NETWORKING (U.S. CLS. 100 AND 101).

KATHERINE CONNOLLY, EXAMINING ATTORNEY

SN 77-846,473. FOUR THIRTEEN VENTURES LLC, FRESNO, CA. FILED 10-12-2009.

GREEN IS GOOD

THE MARK CONSISTS OF STANDARD CHARACTERS WITHOUT CLAIM TO ANY PARTICULAR FONT, STYLE, SIZE, OR COLOR.

CLASS 25—CLOTHING

FOR CLOTHING, NAMELY, T-SHIRTS, SWEAT-SHIRTS, PANTS, SHORTS, HATS AND SOCKS (U.S. CLS. 22 AND 39).

CLASS 35—ADVERTISING AND BUSINESS

FOR PROVIDING A WEB SITE WHERE USERS CAN POST ITEMS FOR SALE THROUGH ON-LINE CLASSIFIED ADVERTISEMENTS (U.S. CLS. 100, 101 AND 102).
SUE LAWRENCE, EXAMINING ATTORNEY

CLASS 43—HOTEL AND RESTAURANT SERVICES

FOR BAR SERVICES; CAFE; CANTEEN SERVICES; CATERING OF FOOD AND DRINKS; HOTEL AND RESTAURANT RESERVATION SERVICES; HOTEL SERVICES; PROVIDING HOTEL ACCOMMODATION; PROVIDING TEMPORARY ACCOMMODATION; RESORT LODGING SERVICES; SNACK BARS; TEA ROOMS; TOURIST HOMES (U.S. CLS. 100 AND 101).
FIRST USE 10-19-2006; IN COMMERCE 10-19-2006.
JULIE VEPPUMTHARA, EXAMINING ATTORNEY

SN 77-848,764. OHARA CORPORATION, KANAGAWA 229-1186, JAPAN, FILED 10-14-2009.

SN 77-847,190. CHONGQING CITYSHINE REAL ESTATE CO. LTD, CHONGQING CITY, CHINA, FILED 10-13-2009.

Hillsun

THE MARK CONSISTS OF STYLIZED WORD "HILLSUN".

CLASS 36—INSURANCE AND FINANCIAL

FOR APARTMENT AND OFFICE RENTALS; APPRAISAL OF REAL ESTATE; BUSINESS BROKERAGE; FINANCIAL GUARANTEE AND SURETY; FINANCIAL MANAGEMENT; LEASING OF REAL ESTATE; MANAGEMENT OF APARTMENTS; REAL ESTATE AGENCIES; REAL ESTATE MANAGEMENT SERVICES; REAL ESTATE SERVICES, NAMELY, PROPERTY MANAGEMENT SERVICES FOR CONDOMINIUM ASSOCIATIONS, HOMEOWNER ASSOCIATIONS AND APARTMENT BUILDINGS (U.S. CLS. 100, 101 AND 102).
FIRST USE 3-17-2003; IN COMMERCE 3-17-2003.

PRIORITY CLAIMED UNDER SEC. 44(D) ON JAPAN APPLICATION NO. 2009029399, FILED 4-17-2009, REG. NO. 5350271, DATED 9-3-2010, EXPIRES 9-3-2020.

OWNER OF U.S. REG. NO. 1,613,599.
THE MARK CONSISTS OF THE WORDS "OHARA", WITH A STAR IN THE MIDDLE OF THE "O".

CLASS 9—ELECTRICAL AND SCIENTIFIC APPARATUS

FOR COMPONENT MATERIALS FOR BATTERIES AND PARTS FOR BATTERIES, NAMELY, GLASS CERAMICS FOR BATTERIES, GLASS CERAMICS FOR BATTERY ELECTROLYTES, GLASS CERAMIC FOR SOLID BATTERY ELECTROLYTES WITH ALL OF THE AFORESAID GOODS SOLD AS AN INTEGRAL PART OF BATTERIES; GLASS CERAMIC REFLECTIVE MATERIAL FOR TELESCOPES SOLD AS A COMPONENT PART OF TELESCOPES (U.S. CLS. 21, 23, 26, 36 AND 38).

CLASS 21—HOUSEWARES AND GLASS

FOR UNWORKED AND SEMI-WORKED GLASS-CERAMICS, NAMELY, LOW EXPANSION GLASS-CERAMICS USED IN FURTHER MANUFACTURE OF ELECTROCHEMICAL DEVICES; GLASS CERAMIC SUBSTRATES FOR MANUFACTURE OF OPTICAL FILTERS; GLASS-CERAMICS AND GLASS SUBSTRATES FOR MANUFACTURE OF HARD DISKS; GLASS DISKS FOR MANUFACTURE OF FLYING HEIGHT TESTERS; DECORATIVE AND ARTISTIC GLASS AND GLASS-CERAMICS FOR MANUFACTURE OF WORKS OF ART MADE OF GLASS; OPTICAL GLASS FOR FURTHER MANUFACTURE OF OPTICAL COMPONENTS, NAMELY, LENSES (U.S. CLS. 2, 13, 23, 29, 30, 33, 40 AND 50).
JACLYN KIDWELL WALKER, EXAMINING ATTORNEY

SN 77-851,636. URCOVEST, LLC, HOLLYWOOD, FL. FILED 10-19-2009.

KEYSTONE ECO

THE MARK CONSISTS OF STANDARD CHARACTERS WITHOUT CLAIM TO ANY PARTICULAR FONT, STYLE, SIZE, OR COLOR.

NO CLAIM IS MADE TO THE EXCLUSIVE RIGHT TO USE "ECO", APART FROM THE MARK AS SHOWN.

CLASS 9—ELECTRICAL AND SCIENTIFIC APPARATUS

FOR CARRYING CASES FOR COMPUTERS; SPECIALTY HOLSTERS FOR CARRYING PORTABLE MUSIC PLAYERS, NAMELY, MP3 PLAYERS, PERSONAL DIGITAL ASSISTANTS (PDA) AND CELLULAR PHONES; AND LIGHT EMITTING DIODE (LED) DISPLAYS (U.S. CLS. 21, 23, 26, 36 AND 38).

CLASS 11—ENVIRONMENTAL CONTROL APPARATUS

FOR LED FLASHLIGHTS FOR ILLUMINATION PURPOSES; AND LED (LIGHT EMITTING DIODE) LIGHTING FIXTURES (U.S. CLS. 13, 21, 23, 31 AND 34).

SUE LAWRENCE, EXAMINING ATTORNEY

SN 77-857,896. SORA HOLDINGS LLC, TOWSON, MD. FILED 10-27-2009.

LIFE-LONG LEARNING ACADEMIC VILLAGE

THE MARK CONSISTS OF STANDARD CHARACTERS WITHOUT CLAIM TO ANY PARTICULAR FONT, STYLE, SIZE, OR COLOR.

NO CLAIM IS MADE TO THE EXCLUSIVE RIGHT TO USE "ACADEMIC VILLAGE", APART FROM THE MARK AS SHOWN.

CLASS 35—ADVERTISING AND BUSINESS

FOR RETAIL STORE SERVICES, NAMELY, RETAIL BOOK STORE SERVICES, RETAIL DEPARTMENT STORES, GIFT AND SUNDRIES RETAIL STORE SERVICES LOCATED IN HOTELS, RETAIL GROCERY STORES, RETAIL DRUG STORES, RETAIL STORE SERVICES FEATURING CONVENIENCE STORE ITEMS AND GASOLINE (U.S. CLS. 100, 101 AND 102).

CLASS 36—INSURANCE AND FINANCIAL

FOR HOUSING AGENCIES; HOUSING SERVICES, NAMELY, RENTAL OF SENIOR RESIDENTIAL HOUSING AND STUDENT HOUSING; APARTMENT RENTALS AND RENTAL OF RESIDENTIAL HOUSING; REAL ESTATE LISTING AND RENTAL SERVICES FOR RESIDENTIAL HOUSING AND APARTMENTS; VACATION REAL ESTATE TIME SHARE EXCHANGE SERVICES; RENTAL OF COMMERCIAL REAL ESTATE; LEASING OF COMMERCIAL REAL ESTATE AND RESIDENTIAL REAL ESTATE; SHOPPING CENTER SERVICES, NAMELY, LEASING OF SHOPPING MALL SPACE; LEASING OF REAL ESTATE (U.S. CLS. 100, 101 AND 102).

CLASS 37—CONSTRUCTION AND REPAIR

FOR DEVELOPMENT AND CONSTRUCTION OF STUDENT HOUSING, SENIOR HOUSING HOSTELS, AND APARTMENTS, NAMELY, REAL ESTATE DEVELOPMENT AND CONSTRUCTION OF RESIDENTIAL PROPERTY (U.S. CLS. 100, 103 AND 106).

CLASS 43—HOTEL AND RESTAURANT SERVICES

FOR BAR SERVICES; RESTAURANT; TAKE OUT RESTAURANT SERVICES; CAFES AND CAFETERIAS; CATERING; ICE CREAM SHOP SERVICES IN THE NATURE OF A RESTAURANT; CARRY OUT RESTAURANTS; DELICATESSENS; RESTAURANTS FEATURING HOME DELIVERY; HOTELS; MOTELS; RESORT LODGING SERVICES; HOSTELS (U.S. CLS. 100 AND 101).

ROBERT STRUCK, EXAMINING ATTORNEY

SN 77-867,762. ALTA EQUIPMENT COMPANY, INC., WIXOM, MI. FILED 11-8-2009.

Alta Fleet Services

THE MARK CONSISTS OF STANDARD CHARACTERS WITHOUT CLAIM TO ANY PARTICULAR FONT, STYLE, SIZE, OR COLOR.

SUBJECT TO CONCURRENT USE PROCEEDING WITH REG. NO. 3662246. OWNER CLAIMS EXCLUSIVE RIGHT TO USE THE MARK IN THE AREA COMPRISING THE STATES OF ALABAMA, ARKANSAS, CONNECTICUT, DELAWARE, FLORIDA, GEORGIA, ILLINOIS, IOWA, KANSAS, KENTUCKY, LOUISIANA, MAINE, MARYLAND, MASSACHUSETTS, MICHIGAN, MINNESOTA, MISSISSIPPI, MISSOURI, NEBRASKA, NEW HAMPSHIRE, NEW JERSEY, NEW YORK, NORTH CAROLINA, NORTH DAKOTA, OHIO, OKLAHOMA, PENNSYLVANIA, RHODE ISLAND, SOUTH CAROLINA, SOUTH DAKOTA, TENNESSEE, VERMONT, VIRGINIA, WEST VIRGINIA AND WISCONSIN.

OWNER OF U.S. REG. NOS. 2,598,846 AND 2,705,077.

NO CLAIM IS MADE TO THE EXCLUSIVE RIGHT TO USE "FLEET SERVICES", APART FROM THE MARK AS SHOWN.

THE ENGLISH TRANSLATION OF "ALTA" IN THE MARK IS HIGH.

CLASS 35—ADVERTISING AND BUSINESS

FOR DISTRIBUTORSHIPS IN THE FIELD OF LIFT TRUCKS AND PARTS, AND IN THE FIELD OF MATERIALS HANDLING EQUIPMENT (U.S. CLS. 100, 101 AND 102).

FIRST USE 11-1-2010; IN COMMERCE 11-1-2010.

CLASS 37—CONSTRUCTION AND REPAIR

FOR REPAIR OR MAINTENANCE OF LOADING-UNLOADING MACHINES AND APPARATUS (U.S. CLS. 100, 103 AND 106).

FIRST USE 11-1-2010; IN COMMERCE 11-1-2010.

CLASS 39—TRANSPORTATION AND STORAGE

FOR LEASING OF TRUCKS (U.S. CLS. 100 AND 105). FIRST USE 11-1-2010; IN COMMERCE 11-1-2010. CHRISTOPHER BUONGIORNO, EXAMINING ATTORNEY

SN 77-888,139. SEKSES DISTRIBUTION LLC, LOS ANGELES, CA. FILED 12-7-2009.



OWNER OF U.S. REG. NOS. 3,732,374, 3,732,390 AND 3,740,825.

THE MARK CONSISTS OF AN ILLUSTRATION OF A BIRD WITH CROSS BONES APPEARING BELOW THE BIRD. THE LETTERS "SA" SEPARATED FROM THE LETTERS "DANISTA" BY A MIRRORED IMAGE OF THE LETTER "N" APPEAR BELOW THE CROSS BONES.

THE WORDING "SANDANISTA" HAS NO MEANING IN A FOREIGN LANGUAGE.

CLASS 14—JEWELRY

FOR JEWELRY; WATCHES (U.S. CLS. 2, 27, 28 AND 50).

FIRST USE 2-6-2009; IN COMMERCE 2-6-2009.

CLASS 25—CLOTHING

FOR CLOTHING, NAMELY, BELTS, BLAZERS, COATS, JACKETS, JEANS, JERSEYS, PULLOVERS, SHIRTS, SHORTS, PANTS, SPORT COATS, SWEAT-SHIRTS, T-SHIRTS, TANK TOPS, SOCKS; HEADGEAR, NAMELY, BASEBALL CAPS, FASHION CAPS, BEANIES, BANDANNAS AND HATS (U.S. CLS. 22 AND 39).

FIRST USE 2-6-2009; IN COMMERCE 2-6-2009.
GISELLE AGOSTO, EXAMINING ATTORNEY

SN 77-900,879. STRATA SOLAR, LLC, CHAPEL HILL, NC. FILED 12-24-2009.

STRATA SOLAR

THE MARK CONSISTS OF STANDARD CHARACTERS WITHOUT CLAIM TO ANY PARTICULAR FONT, STYLE, SIZE, OR COLOR.

NO CLAIM IS MADE TO THE EXCLUSIVE RIGHT TO USE "SOLAR", APART FROM THE MARK AS SHOWN.

CLASS 35—ADVERTISING AND BUSINESS

FOR DISTRIBUTORSHIPS IN THE FIELD OF SOLAR PANELS (U.S. CLS. 100, 101 AND 102).

FIRST USE 4-22-2010; IN COMMERCE 4-22-2010.

CLASS 37—CONSTRUCTION AND REPAIR

FOR INSTALLATION OF SOLAR PANELS (U.S. CLS. 100, 103 AND 106).

FIRST USE 4-22-2010; IN COMMERCE 4-22-2010.

SUE LAWRENCE, EXAMINING ATTORNEY

SN 77-901,516. SAMSUNG ELECTRONICS CO., LTD., SUWON-SI, GYEONGGI-DO, REPUBLIC OF KOREA, FILED 12-28-2009.



PRIORITY CLAIMED UNDER SEC. 44(D) ON REPUBLIC OF KOREA APPLICATION NO. 2009-0063803, FILED 12-24-2009, REG. NO. 0852744, DATED 2-10-2011, EXPIRES 2-10-2021.

THE COLOR(S) BLUE AND LIGHT BLUE IS/ARE CLAIMED AS A FEATURE OF THE MARK.

THE MARK CONSISTS OF THE WORDING "ALLSHARE" IN A STYLIZED FONT WITH A GRADIENT FROM BLUE AT THE TOP TO LIGHT BLUE AT THE BOTTOM, THE WORD "ALL" FORMS THE DESIGN OF A WIRELESS RECEIVER INDICATOR.

CLASS 7—MACHINERY

FOR ELECTRIC WASHING MACHINES FOR CLOTHING; ELECTRIC VACUUM CLEANERS FOR HOUSEHOLD PURPOSES; ELECTRIC MIXERS FOR HOUSEHOLD PURPOSES; AUTOMATIC DISHWASHERS; VACUUM CLEANER BAGS; ROBOTIC VACUUM CLEANERS; LAWNMOWERS; ELECTRIC LAWNMOWERS; WASTE DISPOSERS FOR FOOD; SEWING MACHINES FOR HOUSEHOLD PURPOSES; AIR COMPRESSORS; AUTOMATIC WASHING MACHINES FOR VEHICLES; DC GENERATORS (U.S. CLS. 13, 19, 21, 23, 31, 34 AND 35).

CLASS 9—ELECTRICAL AND SCIENTIFIC APPARATUS

FOR SEMICONDUCTORS; USB CARDS; COMPUTER NETWORK HUBS, SWITCHES AND ROUTERS; MODEMS; SMARTPHONES; MOBILE TELEPHONES; WIRELESS HEADSETS FOR MOBILE PHONES, MP3 PLAYERS AND TELEPHONES; ELECTRIC MOBILE PHONE BATTERY CHARGERS; COMPUTER SERVER; DIGITAL SET-TOP BOXES, NAMELY, DIGITAL MEDIA RECEIVERS AND DECODERS, CABLE TELEVISION CONVERTERS, ETHERNET STREAMING MEDIA CONVERTERS; HARD DISC DRIVES; OPTICAL DISC DRIVES; NOTEBOOK COMPUTERS; COMPUTERS; PRINTERS FOR COMPUTERS; MONITORS FOR COMPUTERS; PERSONAL DIGITAL ASSISTANT; TELEVISION RECEIVERS; FACSIMILE MACHINES; CASH REGISTERS; BATTERIES FOR USE WITH MOBILE PHONES; OPTICAL FIBER CABLES; ELECTRIC FLAT IRONS; AMUSEMENT APPARATUS ADAPTED FOR USE WITH TELEVISION RECEIVERS ONLY; VIDEO TELEPHONES; TELEPHONES; VIDEO TAPE RECORDERS; DVD PLAYERS; MP3 PLAYERS; PORTABLE MULTIMEDIA PLAYERS; AUDIO SPEAKERS FOR COMPUTERS; COMPACT DISC PLAYERS; CAMCORDERS; VIDEO CAMERAS; MOVIE PROJECTORS; GAME SOFTWARE, RECORDED; COMPUTER MICE; COMPUTER MOUSE PADS; VIDEO RECORDERS; VIDEO DISC PLAYERS; HOME THEATER SYSTEMS COMPRISING TELEVISION RECEIVERS, DVD PLAYERS, AUDIO AMPLIFIERS AND AUDIO SPEAKERS (U.S. CLS. 21, 23, 26, 36 AND 38).

CLASS 11—ENVIRONMENTAL CONTROL APPARATUS

FOR WATER PURIFIERS FOR HOUSEHOLD PURPOSES; DISPOSABLE STERILIZATION POUCHES FOR HOUSEHOLD PURPOSES; ICE-COOLING REFRIGERATORS, NON-ELECTRIC; GAS RANGES; BIDET; GAS STOVES; AIR CONDITIONERS; VENTILATORS FOR HOUSEHOLD PURPOSES, NAMELY, FOR AIR CONDITIONERS; GAS LAMPS; AIR HEATERS FOR SHIPS; AIR CONDITIONERS FOR AUTOMOBILES; AIR FILTERING INSTALLATIONS; AIR PURIFYING APPARATUS AND MACHINES; ICE MACHINES AND APPARATUS; ELECTRIC FANS; ELECTRIC REFRIGERATORS; HUMIDIFIERS; HAIR DRYERS; ELECTRIC RANGES; ELECTRIC LAUNDRY DRYERS; ELECTRIC TOASTERS; ELECTRICALLY HEATED CARPETS; MICROWAVE COOKING RANGES; INDUCTION RANGES; BAKING OVENS (U.S. CLS. 13, 21, 23, 31 AND 34).

SEAN CROWLEY, EXAMINING ATTORNEY

SN 77-905,809, EQUINOX HOLDINGS, INC., NEW YORK, NY. FILED 1-6-2010.

MY BODY. MY BIOGRAPHY.

THE MARK CONSISTS OF STANDARD CHARACTERS WITHOUT CLAIM TO ANY PARTICULAR FONT, STYLE, SIZE, OR COLOR.

CLASS 41—EDUCATION AND ENTERTAINMENT

FOR PROVIDING FITNESS AND EXERCISE FACILITIES (U.S. CLS. 100, 101 AND 107).
FIRST USE 1-1-2010; IN COMMERCE 1-1-2010.

CLASS 42—SCIENTIFIC AND COMPUTER SERVICES

FOR HOSTING AN ONLINE WEBSITE FEATURING FITNESS RELATED STORIES AND INFORMATION (U.S. CLS. 100 AND 101).

FIRST USE 1-1-2010; IN COMMERCE 1-1-2010.
LINDA M. KING, EXAMINING ATTORNEY

SN 77-908,129, USA SEVENS LLC, ORANGEBURG, NY. FILED 1-8-2010.

**USA SEVENS RUGBY
INVITATIONAL COLLEGIATE
CHAMPIONSHIP**

THE MARK CONSISTS OF STANDARD CHARACTERS WITHOUT CLAIM TO ANY PARTICULAR FONT, STYLE, SIZE, OR COLOR.

OWNER OF U.S. REG. NO. 3,648,877.

NO CLAIM IS MADE TO THE EXCLUSIVE RIGHT TO USE "SEVENS RUGBY" AND "INVITATIONAL COLLEGIATE CHAMPIONSHIP", APART FROM THE MARK AS SHOWN.

SEC. 2(F) AS TO "USA SEVENS RUGBY".

CLASS 16—PAPER GOODS AND PRINTED MATTER

FOR ADVERTISING SIGNS OF PAPER OR CARDBOARD; APPLIQUES IN THE FORM OF DECALS; AUTOGRAPH BOOKS; BOOK COVERS; BOOKS IN THE FIELD OF RUGBY; BUMPER STICKERS; CALENDARS; COLOR PRINTS; COLORING BOOKS; DECALS; GIFT CARDS; GREETING CARDS; ILLUSTRATED NOTE-PADS; NEWSLETTERS IN THE FIELD OF RUGBY; PAMPHLETS IN THE FIELD OF RUGBY; PAPER BANNERS; PAPER CONTAINERS; PAPER LABELS; PAPER RIBBONS; PAPER STATIONERY; PAPER TAGS; PAPER TAKE-OUT CARTONS FOR FOOD; PLACE MATS OF PAPER; POST CARDS; POSTERS; PRINTED PAPER SIGNS; SCORE CARDS; SPORTS TRADING CARDS; STATIONERY; WALL CALENDARS (U.S. CLS. 2, 5, 22, 23, 29, 37, 38 AND 50).

CLASS 25—CLOTHING

FOR BELTS; BLAZERS; BOTTOMS; CAPS; COATS; GOLF SHIRTS; HATS; HEADBANDS AGAINST SWEATING; HOODED SWEAT SHIRTS; HOODS; HOSIERY; JACKETS; JERSEYS; MUFFLERS; PANTS; RUGBY SHIRTS; RUGBY SHORTS; SHIRTS; SHORTS; SWEAT PANTS; SWEAT SHIRTS; SWEAT SHORTS; SWEAT SUITS; SWEATBANDS; SWEATERS; T-SHIRTS; TIES; TOPS; WALKING SHORTS; WRAPS (U.S. CLS. 22 AND 39).

CLASS 35—ADVERTISING AND BUSINESS

FOR ADVERTISING AND PROMOTIONAL SERVICES; ON-LINE RETAIL STORE SERVICES FEATURING CLOTHING AND SPORTS RELATED MERCHANDISE; PROMOTING SPORTS COMPETITIONS AND/OR EVENTS OF OTHERS; PROMOTING, SPONSORING AND ADMINISTERING AMATEUR ATHLETIC PROGRAMS AND ACTIVITIES; PROVIDING ON-LINE REGISTRATION SERVICES FOR SPORTS TOURNAMENTS (U.S. CLS. 100, 101 AND 102).

CLASS 41—EDUCATION AND ENTERTAINMENT

FOR EDUCATIONAL SERVICES, NAMELY, CONDUCTING ON-LINE EXHIBITIONS AND DISPLAYS AND INTERACTIVE EXHIBITS IN THE FIELD OF RUGBY; EDUCATIONAL SERVICES, NAMELY, CONDUCTING PROGRAMS IN THE FIELD OF RUGBY; EDUCATIONAL SERVICES, NAMELY, CONDUCTING CLASSES, SEMINARS, CONFERENCES, WORKSHOPS IN THE FIELD OF RUGBY; ENTERTAINMENT SERVICES, NAMELY, ARRANGING AND CONDUCTING OF COMPETITIONS FOR SPORTING EVENTS; ENTERTAINMENT SERVICES, NAMELY, CONDUCTING CONTESTS; ENTERTAINMENT, NAMELY, PRODUCTION OF RUGBY FOOTBALL GAMES AND TOURNAMENTS; ORGANISATION OF SPORTS COMPETITIONS (U.S. CLS. 100, 101 AND 107).

AISHA CLARKE, EXAMINING ATTORNEY

SN 77-916,808, QUICKVOX LIMITED, ASHFORD, KENT, UNITED KINGDOM, FILED 1-21-2010.

QUICKVOX

THE MARK CONSISTS OF STANDARD CHARACTERS WITHOUT CLAIM TO ANY PARTICULAR FONT, STYLE, SIZE, OR COLOR.

PRIORITY CLAIMED UNDER SEC. 44(D) ON UNITED KINGDOM APPLICATION NO. 2521627, FILED 7-22-2009, REG. NO. 2521627, DATED 1-8-2010, EXPIRES 7-22-2019.

PRIORITY CLAIMED UNDER SEC. 44(D) ON UNITED KINGDOM APPLICATION NO. 2526526, FILED 9-21-2009, REG. NO. 2526526, DATED 4-9-2010, EXPIRES 9-21-2019.

CLASS 35—ADVERTISING AND BUSINESS

FOR CONDUCTING OPINION POLLS; ADVERTISING SERVICES; ONLINE ADVERTISING ON COMPUTER NETWORKS; DISSEMINATION OF ADVERTISING MATTER; BUSINESS NETWORKING; DATA PROCESSING (U.S. CLS. 100, 101 AND 102).

CLASS 38—COMMUNICATION

FOR COMMUNICATION SERVICES, NAMELY, ELECTRONIC TRANSMISSION OF DATA, SOUND FILES, IMAGES AND DOCUMENTS AMONG USERS OF COMPUTERS; PROVIDING ACCESS TO ELECTRONIC DATABASES; ELECTRONIC EXCHANGE OF DATA STORED IN DATABASES ACCESSIBLE VIA TELECOMMUNICATION NETWORKS; CHAT ROOM SERVICES FOR BUSINESS NETWORKING; PROVIDING ON-LINE FORUMS FOR TRANSMISSION OF MESSAGES AMONG COMPUTER USERS (U.S. CLS. 100, 101 AND 104).

CLASS 45—PERSONAL AND LEGAL SERVICES

FOR ON-LINE SOCIAL NETWORKING SERVICES (U.S. CLS. 100 AND 101).

IRA J. GOODSAD, EXAMINING ATTORNEY

SN 77-919,925, AGGRESSIVE DEVELOPMENT INTERNATIONAL LIMITED, KOWLOON, HONG KONG, FILED 1-26-2010.



THE MARK CONSISTS OF A DOUBLE-HEADED, LONG-NECKED SERPENT WITH OPEN MOUTHS FACING ONE ANOTHER, POSSESSING SYMMETRICAL WINGS ON EACH SIDE OF ITS FEATHERED BODY, WITH LIGHTER-TONED WINGS DIRECTED UPWARDS, CENTER AND LOWER WINGS IN DARKER TONES AND THIN BOTTOM LEG-SHAPED WINGS FACING DOWNWARDS AND OUTWARD, ALONG WITH THE LARGE STYLIZED LETTERS "CHRISTINE" EMBLAZONED ACROSS THE SERPENT'S MID-BODY, WITH A DARK TRACING AROUND THE LETTERS, DOTS AND SPOTS ALSO APPEAR ON TOP OF THE SERPENT'S MID-BODY ABOVE AND BELOW THE WORD "CHRISTINE".

CLASS 9—ELECTRICAL AND SCIENTIFIC APPARATUS

FOR PROTECTIVE SPORTS HELMETS FOR SKATING, SKATE BOARDING, BICYCLING AND HOCKEY (U.S. CLS. 21, 23, 26, 36 AND 38).

CLASS 16—PAPER GOODS AND PRINTED MATTER

FOR PENS, PENCILS AND BOOKS CONTAINING RECREATIONAL ACTIVITIES FOR YOUNG ADULTS (U.S. CLS. 2, 5, 22, 23, 29, 37, 38 AND 50).

CLASS 25—CLOTHING

FOR CLOTHING, NAMELY, CAPS, HATS, BEANIES AND WRISTBANDS (U.S. CLS. 22 AND 39).

CLASS 28—TOYS AND SPORTING GOODS

FOR ICE SKATES; IN-LINE SKATES; ROLLER SKATES; QUAD SKATES; STREET SLIDERS, NAMELY, PAIRS OF WHEELS WHICH AFFIX TO FOOTWEAR FOR PLEASURE AND SPORTS USE; SKATE BOARDS; PROTECTIVE GEAR, NAMELY, KNEE GUARDS, ELBOW GUARDS, AND WRIST GUARDS FOR PROTECTION OF CHILDREN AT PLAY; HOCKEY GOALS; KITES (U.S. CLS. 22, 23, 38 AND 50).

COLLEEN DOMBROW, EXAMINING ATTORNEY

SN 77-928,024, RCN TELECOM SERVICES LLC., HERNDON, VA. FILED 2-4-2010.



OWNER OF U.S. REG. NOS. 2,471,719, 3,119,573 AND OTHERS.

THE COLOR(S) LIGHT BLUE, DARK BLUE, LIGHT GREEN AND DARK GREEN IS/ARE CLAIMED AS A FEATURE OF THE MARK.

THE MARK CONSISTS OF THE LETTERS "R", "C", "N" IN CONTRASTING COLORS OF LIGHT BLUE AND DARK BLUE, AND A STAR DESIGN IN CONTRASTING COLORS OF LIGHT GREEN AND DARK GREEN.

CLASS 38—COMMUNICATION

FOR LOCAL AND LONG DISTANCE TELEPHONE SERVICES; TRANSMISSION OF CABLE TELEVISION AND AUDIO; PROVIDING TELECOMMUNICATIONS CONNECTIONS TO THE INTERNET; VIDEO ON-DEMAND TRANSMISSION SERVICES; TELEPHONE CALL FORWARDING SERVICES; E-MAIL AND INSTANT MESSAGING SERVICES; CALLER IDENTIFICATION SERVICES; VOICE MAIL SERVICES; ONLINE TRANSMISSION OF STREAMED AND DOWNLOADABLE MUSIC FILES; LEASING OF FIBER IN A FIBER-OPTIC TELECOMMUNICATIONS NETWORK; LEASING OF TELECOMMUNICATIONS NETWORK INFRASTRUCTURE, NAMELY, WIRING AND CABLE, CONDUIT, DUCTS, INNERDUCTS, SWITCHES, NODES, DARK FIBER, CIRCUITS AND BACKBONES; STREAMING OF AUDIO AND VIDEO MATERIAL IN THE FIELDS OF NEWS, SPORTS AND ENTERTAINMENT ON THE INTERNET (U.S. CLS. 100, 101 AND 104).

CLASS 41—EDUCATION AND ENTERTAINMENT

FOR PROVIDING ONLINE INFORMATION IN THE FIELD OF CURRENT EVENT NEWS, SPORTS, AND ENTERTAINMENT; DIGITAL VIDEO RECORDING SERVICES; PROVIDING ONLINE COMPUTER GAMES AND INFORMATION IN THE FIELD OF COMPUTER GAMES (U.S. CLS. 100, 101 AND 107).

SHAILA SETTLES, EXAMINING ATTORNEY

SN 77-928,978. FIRST AMERICAN MUSIC AND ENTERTAINMENT, LLC, HOLLYWOOD, FL. FILED 2-5-2010.



NO CLAIM IS MADE TO THE EXCLUSIVE RIGHT TO USE "NATIVE MUSIC" AND "RECORDS" IN CLASSES 9, 16 AND 41, APART FROM THE MARK AS SHOWN.

THE MARK CONSISTS OF THE WORDS "NATIVE MUSIC ROCKS" OVER A DESIGN, WITH THE WORD "RECORDS" UNDERNEATH THE DESIGN.

CLASS 9—ELECTRICAL AND SCIENTIFIC APPARATUS

FOR MUSICAL SOUND RECORDINGS AND MUSICAL AUDIOVISUAL RECORDINGS; SOUND RECORDINGS AND AUDIOVIDEO RECORDINGS CONCERNING MUSICAL ARTISTS; DOWNLOADABLE MUSICAL SOUND RECORDINGS; DOWNLOADABLE SOUND RECORDINGS CONCERNING MUSICAL ARTISTS; DOWNLOADABLE VIDEO RECORDINGS FEATURING MUSIC; DOWNLOADABLE VIDEO RECORDINGS CONCERNING MUSICAL ARTISTS; DOWNLOADABLE ELECTRONIC PUBLICATIONS IN THE NATURE OF BOOKS, BOOKLETS, MAGAZINES, JOURNALS, MANUALS, BROCHURES, LEAFLETS, PAMPHLETS AND NEWSLETTERS, CONCERNING MUSICAL ARTISTS (U.S. CLS. 21, 23, 26, 36 AND 38).

CLASS 16—PAPER GOODS AND PRINTED MATTER

FOR PRINTED MATTER, NAMELY, POSTERS, SHEET MUSIC, TABLATURE BOOKS, SONG BOOKS, TOUR BOOKS RELATING TO A MUSIC ARTIST, MAGAZINES RELATING TO A MUSICAL ARTIST, STICKERS, BUMPER STICKERS, DECALS; PHOTOGRAPHS; AND LITHOGRAPHS (U.S. CLS. 2, 5, 22, 23, 29, 37, 38 AND 50).

CLASS 25—CLOTHING

FOR CLOTHING, NAMELY, SHIRTS, T-SHIRTS, TOPS, SWEAT SHIRTS, CAPS, HATS, WRIST BANDS AND UNDERWEAR (U.S. CLS. 22 AND 39).

CLASS 41—EDUCATION AND ENTERTAINMENT

FOR ENTERTAINMENT, NAMELY, LIVE MUSIC PERFORMANCES; PROVIDING ENTERTAINMENT INFORMATION VIA A COMPUTER COMMUNICATIONS NETWORK, NAMELY, INFORMATION ABOUT APPEARANCES, PERFORMANCES AND RECORDINGS OF MUSIC ARTISTS; INFORMATION SERVICES, NAMELY, PROVIDING A WEB SITE FEATURING MUSICAL PERFORMANCES, MUSICAL VIDEOS, RELATED FILM CLIPS, PHOTOGRAPHS AND OTHER MULTIMEDIA MATERIALS FEATURING MUSIC; FAN CLUB SERVICES; TELEVISION AND RADIO PROGRAM PRODUCTION SERVICES; PRODUCTION AND ORGANIZATION OF LIVE ENTERTAINMENT EVENTS, NAMELY, CONCERTS, CONCERT TOURS AND FESTIVALS IN THE MUSIC FIELD; AND PRODUCTION AND DISTRIBUTION OF MOTION PICTURES AND TELEVISION PROGRAMS, AND PRODUCTION OF SOUND RECORDINGS (U.S. CLS. 100, 101 AND 107).

JANICE L. MCMORROW, EXAMINING ATTORNEY

SN 77-930,663. PACIFIC COAST CONTAINER, INC., SAN LEANDRO, CA. FILED 2-8-2010.

PCC LOGISTICS

THE MARK CONSISTS OF STANDARD CHARACTERS WITHOUT CLAIM TO ANY PARTICULAR FONT, STYLE, SIZE, OR COLOR.

NO CLAIM IS MADE TO THE EXCLUSIVE RIGHT TO USE "LOGISTICS", APART FROM THE MARK AS SHOWN.

CLASS 35—ADVERTISING AND BUSINESS

FOR BUSINESS MANAGEMENT SERVICES, NAMELY, MANAGING SUPPLY CHAIN LOGISTICS AND REVERSE LOGISTICS; FREIGHT LOGISTICS MANAGEMENT (U.S. CLS. 100, 101 AND 102).

FIRST USE 9-30-2004; IN COMMERCE 9-30-2004.

CLASS 39—TRANSPORTATION AND STORAGE

FOR WAREHOUSING SERVICES (U.S. CLS. 100 AND 105).

FIRST USE 9-30-2004; IN COMMERCE 9-30-2004.

DOMINIC FATHY, EXAMINING ATTORNEY

SN 77-933,322. WESTENHORST GMBH & CO. KG, OELDE, FED REP GERMANY, FILED 2-11-2010.



PRIORITY CLAIMED UNDER SEC. 44(D) ON ERP N CMNTY TM OFC APPLICATION NO. 008485121, FILED 8-11-2009, REG. NO. 008485121, DATED 2-22-2010, EXPIRES 8-11-2019.

THE MARK CONSISTS OF A THREE-DIMENSIONAL CONFIGURATION OF A RAISED PYRAMID ARRAY DESIGN PATTERN ON THE BODY OF A BOTTLE, AND A RAISED DESIGN OF TWO CROSSED SWORDS APPEARING BETWEEN THE PYRAMID ARRAY DESIGN PATTERN AND THE NECK OF THE BOTTLE. THE OUTLINE OF THE BOTTLE AND THE BOTTLE CAP ARE SHOWN IN DOTTED LINES TO INDICATE THAT THE SHAPE OF THE BOTTLE AND THE BOTTLE CAP ARE NOT CLAIMED AS A FEATURE OF THE MARK, BUT ARE MERELY SHOWN IN THE DRAWING TO INDICATE THE PLACEMENT OF THE MARK IN RELATION TO THE BOTTLE AND THE BOTTLE CAP.

CLASS 32—LIGHT BEVERAGES

FOR BEERS (U.S. CLS. 45, 46 AND 48).

CLASS 33—WINES AND SPIRITS

FOR ALCOHOLIC BEVERAGES EXCEPT BEERS (U.S. CLS. 47 AND 49).

CLASS 43—HOTEL AND RESTAURANT SERVICES

FOR PROVIDING OF FOOD AND DRINK (U.S. CLS. 100 AND 101).

DAVID ELTON, EXAMINING ATTORNEY

SN 77-933,393. ALTA EQUIPMENT COMPANY, INC., WIXOM, MI. FILED 2-11-2010.

Alta Industrial Equipment

THE MARK CONSISTS OF STANDARD CHARACTERS WITHOUT CLAIM TO ANY PARTICULAR FONT, STYLE, SIZE, OR COLOR.

SUBJECT TO CONCURRENT USE PROCEEDING WITH REG. NO. 3662246. OWNER CLAIMS EXCLUSIVE RIGHT TO USE THE MARK IN THE AREA COMPRISING THE STATES OF ALABAMA, ARKANSAS, CONNECTICUT, DELAWARE, FLORIDA, GEORGIA, ILLINOIS, IOWA, KANSAS, KENTUCKY, LOUISIANA, MAINE, MARYLAND, MASSACHUSETTS, MICHIGAN, MINNESOTA, MISSISSIPPI, MISSOURI, NEBRASKA, NEW HAMPSHIRE, NEW JERSEY, NEW YORK, NORTH CAROLINA, NORTH DAKOTA, OHIO, OKLAHOMA, PENNSYLVANIA, RHODE ISLAND, SOUTH CAROLINA, SOUTH DAKOTA, TENNESSEE, VERMONT, VIRGINIA, WEST VIRGINIA AND WISCONSIN.

OWNER OF U.S. REG. NOS. 2,598,846 AND 2,705,077.

NO CLAIM IS MADE TO THE EXCLUSIVE RIGHT TO USE "INDUSTRIAL EQUIPMENT", APART FROM THE MARK AS SHOWN.

THE ENGLISH TRANSLATION OF "ALTA" IN THE MARK IS "HIGH".

CLASS 37—CONSTRUCTION AND REPAIR

FOR LEASING OF CONSTRUCTION EQUIPMENT (U.S. CLS. 100, 103 AND 106).

FIRST USE 11-1-2010; IN COMMERCE 11-1-2010.

CLASS 39—TRANSPORTATION AND STORAGE

FOR LEASING OF TRUCKS (U.S. CLS. 100 AND 105).

FIRST USE 11-1-2010; IN COMMERCE 11-1-2010.

CHRISTOPHER BUONGIORNO, EXAMINING ATTORNEY

SN 77-934,665. BLEETBOX LIMITED, SEVENOAKS, KENT, UNITED KINGDOM, FILED 2-12-2010.

BLEETBOX

THE MARK CONSISTS OF STANDARD CHARACTERS WITHOUT CLAIM TO ANY PARTICULAR FONT, STYLE, SIZE, OR COLOR.

PRIORITY CLAIMED UNDER SEC. 44(D) ON ERPNTY TM OFC APPLICATION NO. 008689929, FILED 11-16-2009, REG. NO. 008689929, DATED 6-15-2010, EXPIRES 11-16-2019.

CLASS 35—ADVERTISING AND BUSINESS

FOR ADVERTISING SERVICES; BUSINESS MANAGEMENT; BUSINESS ADMINISTRATION AND MANAGEMENT; BUSINESS OPERATION; BUSINESS ADMINISTRATION AND OFFICE FUNCTIONS; THE PROVISION OF ADVERTISING SPACE BY ELECTRONIC MEANS AND GLOBAL INFORMATION NETWORKS; PROMOTING THE GOODS AND SERVICES OF OTHERS BY MEANS OF DISTRIBUTING ADVERTISING ON THE INTERNET; DISSEMINATION OF ADVERTISEMENTS; ADVERTISING CONSULTATION AND ADVISORY SERVICES; PROVIDING ADVERTISING-RELATED INFORMATION VIA THE INTERNET, AND RENTAL OF ADVERTISING SPACE (U.S. CLS. 100, 101 AND 102).

CLASS 38—COMMUNICATION

FOR PROVIDING ONLINE CHAT ROOMS FOR SOCIAL NETWORKING; PROVIDING ACCESS TO ELECTRONIC SITES; PROVISION OF ACCESS TO THE INTERNET; PROVISION OF ACCESS TO A GLOBAL COMPUTER NETWORK; ELECTRONIC TRANSMISSION OF MAIL AND MESSAGES; TELECOMMUNICATIONS CONSULTATION; INFORMATION ABOUT TELECOMMUNICATIONS (U.S. CLS. 100, 101 AND 104).

CLASS 39—TRANSPORTATION AND STORAGE

FOR ELECTRONIC DOCUMENT AND EMAIL ARCHIVING SERVICES (U.S. CLS. 100 AND 105).

CLASS 41—EDUCATION AND ENTERTAINMENT

FOR ORGANIZING COMMUNITY SPORTING AND CULTURAL EVENTS; PROVISION OF INFORMATION ONLINE IN THE FIELD OF ENTERTAINMENT AND EDUCATION (U.S. CLS. 100, 101 AND 107).

MARC LEIPZIG, EXAMINING ATTORNEY

SN 77-936,581. LUMETRA HEALTHCARE SOLUTIONS, INC., SAN FRANCISCO, CA. FILED 2-16-2010.



THE COLOR(S) YELLOW, GREEN, BLUE, TURQUOISE AND WHITE IS/ARE CLAIMED AS A FEATURE OF THE MARK.

THE MARK CONSISTS OF THE FOLLOWING: THREE OVERLAPPING CIRCLES, ONE CIRCLE IN YELLOW, A SECOND CIRCLE IN BLUE, AND A THIRD CIRCLE IN GREEN; WHERE TWO CIRCLES INTERSECT THE COLOR IS TURQUOISE AND THE CENTER WHERE ALL THREE CIRCLES INTERSECT IS THE COLOR WHITE.

CLASS 35—ADVERTISING AND BUSINESS

FOR ASSOCIATION SERVICES, NAMELY, PROMOTING THE INTERESTS OF HEALTH CARE PATIENTS; BUSINESS CONSULTING SERVICES TO THE HEALTH CARE INDUSTRY, NAMELY, PROVIDING INDUSTRY EXPERTISE AND SUPPLIER PARTNERSHIPS TO IMPROVE THE SYSTEMS AND PROCESSES FOR HEALTH CARE DELIVERY; CONSULTING IN THE FIELD OF HEALTHCARE OPERATIONS MANAGEMENT TO IMPROVE THE SYSTEMS AND PROCESSES FOR HEALTH CARE DELIVERY; MANAGEMENT OF COMPUTER DATABASES CONTAINING INFORMATION IN THE FIELD OF HEALTH CARE; HEALTH CARE UTILIZATION AND REVIEW SERVICES, NAMELY, MEDICAL RECORD DATA ABSTRACTION AND DATA ANALYSES FOR HEALTH CARE PROVIDERS, PURCHASERS AND GROUPS INTERESTED IN HEALTH CARE, AND PROVIDING CASE REVIEW SERVICES FOR HEALTH CARE PURCHASERS AND HEALTH CARE BENEFITS PROGRAM BENEFICIARIES (U.S. CLS. 100, 101 AND 102).
FIRST USE 11-30-2009; IN COMMERCE 11-30-2009.

CLASS 42—SCIENTIFIC AND COMPUTER SERVICES

FOR MEDICAL RESEARCH, NAMELY, STATISTICAL AND DATA ANALYSES OF PERSONAL AND POPULATION BASED MEDICAL HISTORY RECORDS AND FILES; QUALITY CONTROL FOR OTHERS, NAMELY, HEALTHCARE PROVIDERS AND PAYERS; DESIGN OF COMPUTER DATABASES CONTAINING INFORMATION IN THE FIELD OF HEALTHCARE (U.S. CLS. 100 AND 101).
FIRST USE 11-30-2009; IN COMMERCE 11-30-2009.

CLASS 44—MEDICAL, BEAUTY AND AGRICULTURAL SERVICES

FOR PROVIDING INFORMATION VIA A GLOBAL COMPUTER NETWORK RELATING TO HEALTHCARE; CONSULTATION IN THE FIELD OF HEALTHCARE; ADVISING HEALTHCARE PROVIDERS AND PAYERS ON THE SUBJECT OF PROVIDING EFFECTIVE AND QUALITY HEALTHCARE; DESIGNING HEALTHCARE DELIVERY SYSTEMS AND PROCESSES RELATING TO HEALTHCARE DELIVERY (U.S. CLS. 100 AND 101).
FIRST USE 11-30-2009; IN COMMERCE 11-30-2009.
WON TEAK OH, EXAMINING ATTORNEY

CLASS 35—ADVERTISING AND BUSINESS

FOR ASSOCIATION SERVICES, NAMELY, PROMOTING THE INTERESTS OF HEALTH CARE PATIENTS; BUSINESS CONSULTING SERVICES TO THE HEALTH CARE INDUSTRY, NAMELY, PROVIDING INDUSTRY EXPERTISE AND SUPPLIER PARTNERSHIPS TO IMPROVE THE SYSTEMS AND PROCESSES FOR HEALTH CARE DELIVERY; CONSULTING IN THE FIELD OF HEALTHCARE OPERATIONS MANAGEMENT TO IMPROVE THE SYSTEMS AND PROCESSES FOR HEALTH CARE DELIVERY; MANAGEMENT OF COMPUTER DATABASES CONTAINING INFORMATION IN THE FIELD OF HEALTH CARE; HEALTH CARE UTILIZATION AND REVIEW SERVICES, NAMELY, MEDICAL RECORD DATA ABSTRACTION AND DATA ANALYSES FOR HEALTH CARE PROVIDERS, PURCHASERS AND GROUPS INTERESTED IN HEALTH CARE, AND PROVIDING CASE REVIEW SERVICES FOR HEALTH CARE PURCHASERS AND HEALTH CARE BENEFITS PROGRAM BENEFICIARIES (U.S. CLS. 100, 101 AND 102).
FIRST USE 11-30-2009; IN COMMERCE 11-30-2009.

CLASS 42—SCIENTIFIC AND COMPUTER SERVICES

FOR MEDICAL RESEARCH, NAMELY, STATISTICAL AND DATA ANALYSES OF PERSONAL AND POPULATION BASED MEDICAL HISTORY RECORDS AND FILES; QUALITY CONTROL FOR OTHERS, NAMELY, HEALTHCARE PROVIDERS AND PAYERS; DESIGN OF COMPUTER DATABASES CONTAINING INFORMATION IN THE FIELD OF HEALTHCARE (U.S. CLS. 100 AND 101).
FIRST USE 11-30-2009; IN COMMERCE 11-30-2009.

CLASS 44—MEDICAL, BEAUTY AND AGRICULTURAL SERVICES

FOR PROVIDING INFORMATION VIA A GLOBAL COMPUTER NETWORK RELATING TO HEALTHCARE; CONSULTATION IN THE FIELD OF HEALTHCARE; ADVISING HEALTHCARE PROVIDERS AND PAYERS ON THE SUBJECT OF PROVIDING EFFECTIVE AND QUALITY HEALTHCARE; DESIGNING HEALTHCARE DELIVERY SYSTEMS AND PROCESSES RELATING TO HEALTHCARE DELIVERY (U.S. CLS. 100 AND 101).
FIRST USE 11-30-2009; IN COMMERCE 11-30-2009.
WON TEAK OH, EXAMINING ATTORNEY

SN 77-936,583. LUMETRA HEALTHCARE SOLUTIONS, INC., SAN FRANCISCO, CA. FILED 2-16-2010.

LUMETRA HEALTHCARE SOLUTIONS

THE MARK CONSISTS OF STANDARD CHARACTERS WITHOUT CLAIM TO ANY PARTICULAR FONT, STYLE, SIZE, OR COLOR.
OWNER OF U.S. REG. NOS. 3,015,932 AND 3,635,664.
NO CLAIM IS MADE TO THE EXCLUSIVE RIGHT TO USE "HEALTHCARE SOLUTIONS", APART FROM THE MARK AS SHOWN.

SN 77-936,871. FITO PERU EXPORT IMPORT S.A.C., LIMA, PERU, FILED 2-16-2010.



OWNER OF U.S. REG. NO. 3,634,311.
NO CLAIM IS MADE TO THE EXCLUSIVE RIGHT TO USE "PERUVIANS", APART FROM THE MARK AS SHOWN.

THE MARK CONSISTS OF THE WORD "HANAN" IN STYLIZED LETTERING, WITH THE PHRASE "PERUVIANS SECRETS" DIRECTLY UNDERNEATH THE WORD "HANAN", WHEREIN A STYLIZED TEACUP ELEMENT IS DIRECTLY ABOVE THE WORD "HANAN", WHEREIN THREE CURVED ELEMENTS EXTEND DIAGONALLY UPWARD TO THE RIGHT FROM ABOVE THE TEACUP ELEMENT, WHEREIN THE THREE CURVED ELEMENTS ARE INTENDED TO REPRESENT WISPS OF STEAM EMANATING FROM THE TEACUP ELEMENT.

CLASS 16—PAPER GOODS AND PRINTED MATTER

FOR PAPER, CARDBOARD AND GOODS MADE FROM THESE MATERIALS, NAMELY, PACKAGING MATERIALS; OFFICE ARTICLES, NAMELY, ADHESIVE COATED PAPER FOR STATIONERY PURPOSES, ADHESIVE MATERIALS FOR STATIONERY PURPOSES, LETTERHEAD PAPER, ENVELOPES, BUSINESS CARDS, STICKERS, AND ADHESIVE TAPES FOR STATIONERY PURPOSES; AND PLASTIC MATERIALS FOR PACKAGING, NAMELY, BAGS AND BUBBLE PACKS (U.S. CLS. 2, 5, 22, 23, 29, 37, 38 AND 50).

CLASS 30—STAPLE FOODS

FOR TEAS AND AROMATIC HERBS, IN EITHER PACKAGED OR BULK FORM, EITHER SEPARATED OR MIXED (U.S. CL. 46).

DAVID HOFFMAN, EXAMINING ATTORNEY

CLASS 36—INSURANCE AND FINANCIAL

FOR FINANCIAL ASSET MANAGEMENT, NAMELY, MANAGEMENT OF ASSETS IN ALTERNATIVE INVESTMENTS SUCH AS PRIVATE EQUITY, PRIVATE DEBT, HEDGE FUNDS, REAL ESTATE AND INFRASTRUCTURE; INVESTMENTS SERVICES IN EQUITY FUNDS, LISTED PRIVATE EQUITY, DIRECT INVESTMENTS AND ALTERNATIVE BETA STRATEGIES; ASSESSMENT OF STRATEGIC ASSET ALLOCATION; FINANCIAL DUE DILIGENCE; INVESTMENT MONITORING AND INVESTMENT REPORTING; VENTURE CAPITAL FINANCING SERVICES, NAMELY, PROVIDING VENTURE CAPITAL, GROWTH CAPITAL AND CAPITAL FOR BUYOUTS AND TURNAROUNDS; VALUATION OF INVESTMENTS; MANAGEMENT OF INVESTMENT ACCOUNTS; FINANCIAL PORTFOLIO MANAGEMENT (U.S. CLS. 100, 101 AND 102).

DOMINIC FATHY, EXAMINING ATTORNEY

SN 77-938,310. OCP HOLDINGS, LLC, ELK GROVE VILLAGE, IL. FILED 2-17-2010.

SN 77-938,048. PARTNERS GROUP AG, 6431 BAAR, SWITZERLAND, FILED 2-17-2010.



PRIORITY CLAIMED UNDER SEC. 44(D) ON SWITZERLAND APPLICATION NO. 50783/2010, FILED 1-26-2010, REG. NO. 598917, DATED 1-26-2010, EXPIRES 1-26-2020. OWNER OF U.S. REG. NOS. 3,434,801 AND 3,602,689.

NO CLAIM IS MADE TO THE EXCLUSIVE RIGHT TO USE "GROUP" AND "PRIVATE MARKETS", APART FROM THE MARK AS SHOWN.

THE MARK CONSISTS OF A SPHERE SHAPED PUZZLE NEXT TO THE WORDS "PARTNERS GROUP PASSION FOR PRIVATE MARKETS".

SEC. 2(F) AS TO "PARTNERS".

CLASS 35—ADVERTISING AND BUSINESS

FOR ADVERTISING SERVICES; BUSINESS MANAGEMENT; BUSINESS ADMINISTRATION; PROVIDING OFFICE FUNCTIONS (U.S. CLS. 100, 101 AND 102).



NO CLAIM IS MADE TO THE EXCLUSIVE RIGHT TO USE "POLITICS", APART FROM THE MARK AS SHOWN.

THE COLOR(S) RED, BLUE AND BLACK IS/ARE CLAIMED AS A FEATURE OF THE MARK.

THE MARK CONSISTS OF COMPOUNDED WORD "ONECLICK" IN BLUE LETTERS FOLLOWED BY A FADING BLUE BOX WITH BLACK SHADOW AND RED ARROW FOLLOWED BY THE WORD "POLITICS" IN RED LETTERS.

CLASS 38—COMMUNICATION

FOR ONLINE WEBSITE SERVICES PROVIDING COMMUNICATIONS TO THIRD PARTIES, NAMELY, ELECTRONIC TRANSMISSION OF EMAIL AND TEXT MESSAGES TO ELECTED REPRESENTATIVES OR GOVERNMENT OFFICIALS; ONLINE WEBSITE SERVICES PROVIDING ELECTRONIC COMMUNICATIONS TO THIRD PARTIES, NAMELY, PROVIDING MESSAGING SERVICES VIA THE INTERNET (U.S. CLS. 100, 101 AND 104).

FIRST USE 6-4-2010; IN COMMERCE 6-4-2010.

CLASS 42—SCIENTIFIC AND COMPUTER SERVICES

FOR ONLINE WEBSITE SERVICES PROVIDING COMMUNICATIONS TO THIRD PARTIES, NAMELY, PROVIDING AN INTERACTIVE ONLINE USER INTERFACE WEB SITE THAT ALLOWS FOR THE TRANSMISSION OF ELECTRONIC AND EMAIL MESSAGES TO ELECTED REPRESENTATIVES OR GOVERNMENT OFFICIALS (U.S. CLS. 100 AND 101).

FIRST USE 6-4-2010; IN COMMERCE 6-4-2010.

JENNIFER MARTIN, EXAMINING ATTORNEY

SN 77-938,971. LLM MANAGEMENT CO., LLC, NEW YORK, NY. FILED 2-18-2010.

COMPLETELY LIZ

THE MARK CONSISTS OF STANDARD CHARACTERS WITHOUT CLAIM TO ANY PARTICULAR FONT, STYLE, SIZE, OR COLOR.

CLASS 3—COSMETICS AND CLEANING PREPARATIONS

FOR BABY LOTION; BABY OIL; BAR SOAP; BATH CREAM; BATH CRYSTALS; BATH FOAM; BATH GELS; BEAUTY CREAMS; BLUSH; BODY CREAM; BODY GLITTER; BODY SPLASH; COLOGNE; COSMETIC CREAMS; COSMETIC OILS; COSMETICS; EAU DE TOILETTE AND EAU DE COLOGNE; ESSENTIAL OILS; EXFOLIANT CREAMS; EYE MAKE-UP; FACE CREAMS; FRAGRANCES; HAIR CARE PREPARATIONS; HAIR GEL AND HAIR MOUSSE; HAIR SHAMPOOS AND CONDITIONERS; HAND CREAMS; HAND LOTIONS; LIP BALM; LIPSTICK; MAKE-UP; NAIL POLISH; PERFUME; POTPOURRI; SUN BLOCK; SUNSCREEN CREAM (U.S. CLS. 1, 4, 6, 50, 51 AND 52).

CLASS 9—ELECTRICAL AND SCIENTIFIC APPARATUS

FOR AUTOMATED PROCESS CONTROL SYSTEM, NAMELY, MICRO-PROCESSOR BASED HARDWARE AND SOFTWARE USED TO MONITOR THE STATUS OF INDUSTRIAL PROCESSES, NAMELY, POWER GENERATION, ELECTRICAL DISTRIBUTION AND OIL AND GAS PROCESSING; CAMERAS; CARRYING CASES FOR CELL PHONES; CD PLAYERS; CELLULAR PHONE ACCESSORY CHARMS; CELLULAR PHONES; DIGITAL AUDIO PLAYERS; DIGITAL CAMERAS; DIGITAL CELLULAR PHONES; DVD PLAYERS; LAPTOP CARRYING CASES; MP3 PLAYERS (U.S. CLS. 21, 23, 26, 36 AND 38).

CLASS 14—JEWELRY

FOR ALARM CLOCKS; ANKLE BRACELETS; BANGLES; BRACELETS; BROOCHES; CHARMS; CHOKERS; CLIP EARRINGS; CLOCKS AND WATCHES; COSTUME JEWELRY; CUFF LINKS; EAR CLIPS; EARRINGS; GEMSTONE JEWELRY; JEWELLERY; JEWELRY; JEWELRY BOXES; LOCKETS; RINGS; TIE CLIPS; TIMEPIECES; WATCHES (U.S. CLS. 2, 27, 28 AND 50).

CLASS 18—LEATHER GOODS

FOR ALL-PURPOSE ATHLETIC BAGS; ALL-PURPOSE CARRYING BAGS; ATTACHE CASES; BACKPACKS; BACKPACKS, BOOK BAGS, SPORTS BAGS, BUM BAGS, WALLETS AND HANDBAGS; BAGS FOR CARRYING BABIES' ACCESSORIES; BEACH BAGS; BOOK BAGS; BRIEFCASES; CARD WALLETS; CARRY-ALL BAGS; CLUTCH BAGS; COIN PURSES; COSMETIC BAGS SOLD EMPTY; DUFFEL BAGS; GYM BAGS; HANDBAGS; KEY WALLETS; LEATHER BAGS AND WALLETS; LEATHER CASES; LEATHER HANDBAGS; LEATHER PURSES; LUGGAGE; POCKET WALLETS; PURSES; SUITCASES; UMBRELLAS; WALLETS (U.S. CLS. 1, 2, 3, 22 AND 41).

CLASS 25—CLOTHING

FOR BEACHWEAR; BELTS; BLAZERS; BLOUSES; BOW TIES; COATS; DENIM JACKETS; DENIMS; DRESS SHIRTS; DRESSES; FOOTBALL SHOES; FOOTWEAR; HATS; HEADWEAR; HOSIERY; INFANT WEAR; INFANTWEAR; JACKETS; JEANS; JERSEYS; LADIES' UNDERWEAR; LEGGINGS; LINGERIE; LOUNGEWEAR; NECKWEAR; NIGHT GOWNS; NIGHTWEAR; OUTDOOR GLOVES; OUTER JACKETS; OVER COATS; OVER SHIRTS; PAJAMAS; PANTIES, SHORTS AND BRIEFS; POLO SHIRTS; PONCHOS; RAIN COATS; RAINCOATS; SCARVES; SHIRTS; SHOES; SHORTS; SKIRTS; SKIRTS AND DRESSES; SKORTS; SLACKS; SLEEPWEAR; SLIPOVERS; SLIPPERS; SOCKS; SPORT SHIRTS; SUITS; SWEAT PANTS; SWEAT SHIRTS; SWEATERS; SWIM WEAR; SWIMWEAR; T-SHIRTS; TANK TOPS; UNDERWEAR; VESTS (U.S. CLS. 22 AND 39).
COLLEEN DOMBROW, EXAMINING ATTORNEY

SN 77-951,373. DESTINY HEALTH, INC., CHICAGO, IL. FILED 3-5-2010.

VITALITY JACKPOT

THE MARK CONSISTS OF STANDARD CHARACTERS WITHOUT CLAIM TO ANY PARTICULAR FONT, STYLE, SIZE, OR COLOR.
OWNER OF U.S. REG. NOS. 2,800,989, 3,381,251 AND OTHERS.

CLASS 35—ADVERTISING AND BUSINESS

FOR PROVIDING ASSISTANCE, FITNESS EVALUATION AND CONSULTATION TO BUSINESSES TO HELP THEIR EMPLOYEES MAKE HEALTH, WELLNESS AND NUTRITIONAL CHANGES IN THEIR DAILY LIVING TO INCREASE PRODUCTIVITY AND LOWER HEALTH CARE COSTS (U.S. CLS. 100, 101 AND 102).

CLASS 42—SCIENTIFIC AND COMPUTER SERVICES

FOR APPLICATION SERVICE PROVIDER, NAMELY, PROVIDING, HOSTING, MANAGING, DEVELOPING, RESEARCHING, ANALYZING, REPORTING, AND MAINTAINING APPLICATIONS, SOFTWARE AND DATABASES FOR OTHERS IN THE FIELDS OF EMPLOYEE HEALTH INSURANCE AND WELLNESS PROGRAMS (U.S. CLS. 100 AND 101).
ALYSSA STEEL, EXAMINING ATTORNEY

SN 77-953,578. KIMA LABS, INC., SAN FRANCISCO, CA. FILED 3-8-2010.

KIMA

THE MARK CONSISTS OF STANDARD CHARACTERS WITHOUT CLAIM TO ANY PARTICULAR FONT, STYLE, SIZE, OR COLOR.

CLASS 9—ELECTRICAL AND SCIENTIFIC APPARATUS

FOR COMPUTER SOFTWARE, NAMELY, SOFTWARE FOR USE IN LOCATING, EVALUATING, OBTAINING AND PROVIDING INFORMATION ABOUT, AND PURCHASING THE PRODUCTS AND SERVICES OF OTHERS, FOR ENABLING INDIVIDUALS AND GROUPS TO COMMUNICATE WITH EACH OTHER REGARDING THE PRODUCTS AND SERVICES OF OTHERS, AND FOR ENHANCING A CONSUMERS SHOPPING EXPERIENCE BY RECORDING, TRACKING, REPORTING AND ANALYZING CONSUMERS SHOPPING HISTORY, PATTERNS, EXPERIENCES AND RESULTS (U.S. CLS. 21, 23, 26, 36 AND 38).

CLASS 35—ADVERTISING AND BUSINESS

FOR BUSINESS MANAGEMENT CONSULTING SERVICES, NAMELY, COLLECTING, EVALUATING AND PROVIDING FEEDBACK TO BUSINESSES AND MERCHANTS REGARDING THEIR STORES, MERCHANDISE, AND ALL ASPECTS OF THEIR OPERATIONS; ADVERTISING AND PROMOTIONAL SERVICES (U.S. CLS. 100, 101 AND 102).

CLASS 38—COMMUNICATION

FOR PROVIDING ACCESS TO TELECOMMUNICATION NETWORKS THAT ENABLE INDIVIDUALS AND GROUPS TO COMMUNICATE WITH EACH OTHER VIA HANDHELD COMMUNICATION DEVICES (U.S. CLS. 100, 101 AND 104).

CLASS 42—SCIENTIFIC AND COMPUTER SERVICES

FOR COMPUTER SERVICES, NAMELY, DESIGN AND DEVELOPMENT OF COMPUTER SOFTWARE FOR USE IN LOCATING, EVALUATING, OBTAINING AND PROVIDING INFORMATION ABOUT, AND PURCHASING THE PRODUCTS AND SERVICES OF OTHERS, FOR ENABLING INDIVIDUALS AND GROUPS TO COMMUNICATE WITH EACH OTHER REGARDING THE PRODUCTS AND SERVICES OF OTHERS, FOR ENHANCING A CONSUMERS SHOPPING EXPERIENCE AND FOR RECORDING, TRACKING, REPORTING AND ANALYZING CONSUMERS SHOPPING HISTORY, PATTERNS, EXPERIENCES AND RESULTS; PROVIDING TEMPORARY USE OF NON-DOWNLOADABLE SOFTWARE FOR USE WITH MOBILE COMMUNICATION DEVICES FOR USE IN LOCATING, EVALUATING, OBTAINING AND PROVIDING INFORMATION ABOUT, AND PURCHASING THE PRODUCTS AND SERVICES OF OTHERS, FOR ENABLING INDIVIDUALS AND GROUPS TO COMMUNICATE WITH EACH OTHER REGARDING THE PRODUCTS AND SERVICES OF OTHERS, FOR ENHANCING A CONSUMERS SHOPPING EXPERIENCE AND FOR RECORDING, TRACKING, ANALYZING AND REPORTING ON CONSUMERS SHOPPING HISTORY, PATTERNS, EXPERIENCES AND RESULTS (U.S. CLS. 100 AND 101).

CLASS 45—PERSONAL AND LEGAL SERVICES

FOR ONLINE SOCIAL NETWORKING SERVICES THAT MAY BE ACCESSED VIA COMPUTERS AND MOBILE DEVICES (U.S. CLS. 100 AND 101).
NICHOLAS ALTREE, EXAMINING ATTORNEY

SN 77-953,639. HANSEN BEVERAGE COMPANY, CORONA, CA. FILED 3-8-2010.

CARB COOL

THE MARK CONSISTS OF STANDARD CHARACTERS WITHOUT CLAIM TO ANY PARTICULAR FONT, STYLE, SIZE, OR COLOR.

NO CLAIM IS MADE TO THE EXCLUSIVE RIGHT TO USE "CARB", APART FROM THE MARK AS SHOWN.

CLASS 5—PHARMACEUTICALS

FOR NUTRITIONAL SUPPLEMENTS (U.S. CLS. 6, 18, 44, 46, 51 AND 52).

CLASS 32—LIGHT BEVERAGES

FOR NON-ALCOHOLIC BEVERAGES, NAMELY, CARBONATED AND NON-CARBONATED ENERGY DRINKS OR SPORTS DRINKS; SOFT DRINKS; CARBONATED SOFT DRINKS; FRUIT JUICE DRINKS; AND CARBONATED FRUIT JUICE DRINKS ALL ENHANCED WITH VITAMINS, MINERALS, NUTRIENTS, AMINO ACIDS, AND/OR HERBS (U.S. CLS. 45, 46 AND 48).

KELLEY WELLS, EXAMINING ATTORNEY

SN 77-958,673. HOLYOAKE INSTITUTE FOR ALCOHOL AND DRUG ADDICTION RESOLUTIONS, INC, VICTORIA PARK, WA, AUSTRALIA, FILED 3-15-2010.

DRUMBEAT

THE MARK CONSISTS OF STANDARD CHARACTERS WITHOUT CLAIM TO ANY PARTICULAR FONT, STYLE, SIZE, OR COLOR.

OWNER OF AUSTRALIA REG. NO. 1253205, DATED 7-23-2008, EXPIRES 7-23-2018.

CLASS 41—EDUCATION AND ENTERTAINMENT

FOR EDUCATIONAL SERVICES, NAMELY, CONDUCTING CLASSES, WORKSHOPS, SEMINARS AND CONFERENCE PRESENTATIONS FOR PERSONS SUFFERING FROM OR 'AT RISK' OF SUBSTANCE ABUSE AND FAMILIES OF PERSONS SUFFERING FROM SUBSTANCE ABUSE; EDUCATION SERVICES, NAMELY, PROVIDING CLASSES, WORKSHOPS, SEMINARS AND CONFERENCE PRESENTATIONS IN THE FIELDS OF PERSONAL AND SOCIAL DEVELOPMENT, RESILIENCE TRAINING AND RELATIONSHIP COUNSELING; PROVISION OF TRAINING IN THE FIELDS OF PERSONAL AND SOCIAL DEVELOPMENT, RESILIENCE TRAINING, RELATIONSHIP COUNSELING, RELAPSE PREVENTION TRAINING, AND ANGER MANAGEMENT (U.S. CLS. 100, 101 AND 107).

CLASS 44—MEDICAL, BEAUTY AND AGRICULTURAL SERVICES

FOR THERAPEUTIC REHABILITATION, THERAPEUTIC EARLY INTERVENTION AND MEDICAL SERVICES FOR PERSONS SUFFERING FROM SUBSTANCE ABUSE, NAMELY, PROGRAMS DIRECTED AT YOUNG PEOPLE AT RISK OF FUTURE PROBLEMATIC SUBSTANCE ABUSE, PEOPLE WITH A MENTAL HEALTH DIAGNOSIS, PEOPLE WITH CO-OCCURRING DRUG USE AND MENTAL HEALTH CONDITIONS, PEOPLE WITH HISTORIES OF OFFENDING, CHILDREN AND ADULTS SUFFERING FROM TRAUMA, PEOPLE WITH ONGOING RELATIONSHIP PROBLEMS (U.S. CLS. 100 AND 101).

CLASS 45—PERSONAL AND LEGAL SERVICES

FOR PERSONAL AND SOCIAL SERVICES, NAMELY, PROVIDING INFORMATION IN THE FIELDS OF COUNSELING AND GROUP SUPPORT FOR PEOPLE SUFFERING FROM SOCIAL ISOLATION DUE TO SUBSTANCE ABUSE, MENTAL HEALTH CONDITIONS, CRIMINALITY OR CULTURAL DISADVANTAGE; PROVISION OF SUPPORT SERVICES FOR PERSONS SUFFERING FROM SUBSTANCE ABUSE, NAMELY, GROUP SOCIAL SKILLS COUNSELING SESSIONS AND ONGOING CASE WORK SUPPORT, NAMELY, COORDINATION OF NECESSARY MEDICAL SERVICES, VOCATIONAL ISSUES AND EDUCATIONAL SERVICES FOR SOCIALLY ISOLATED INDIVIDUALS; PROVISION OF SUPPORT SERVICES FOR FAMILIES OF PERSONS SUFFERING FROM SUBSTANCE ABUSE, NAMELY, EMOTIONAL COUNSELING AND EMOTIONAL SUPPORT; PROVISION OF SUBSTANCE ABUSE EMOTIONAL SUPPORT AND RELATIONSHIP COUNSELING SERVICES, OTHER THAN MEDICAL OR PSYCHOLOGICAL COUNSELING (U.S. CLS. 100 AND 101).

JOSETTE BEVERLY, EXAMINING ATTORNEY

SN 77-960,142. INGAZZI LIMITED, POOLE, DORSET, UNITED KINGDOM, FILED 3-16-2010.

FIZZICALLY PERFECT

THE MARK CONSISTS OF STANDARD CHARACTERS WITHOUT CLAIM TO ANY PARTICULAR FONT, STYLE, SIZE, OR COLOR.

PRIORITY CLAIMED UNDER SEC. 44(D) ON ERPN CMNTY TM OFC APPLICATION NO. 008919201, FILED 3-1-2010, REG. NO. 008919201, DATED 9-2-2010, EXPIRES 3-1-2020.

CLASS 6—METAL GOODS

FOR METAL CONTAINERS SOLD EMPTY; METALLIC BOTTLES FOR PRESSURIZED GAS OR AIR SOLD EMPTY; BOTTLE CAPS OF METAL; METAL BOTTLE CAPS INCORPORATING VALVES; METAL BOTTLE LIDS; METAL BOTTLE LIDS INCORPORATING VALVES; METAL CYLINDERS FOR COMPRESSED GAS SOLD EMPTY; METAL CYLINDERS FOR COMPRESSED GAS SOLD EMPTY FOR USE WITH GAS GUNS; METAL CARBON DIOXIDE GAS CYLINDERS SOLD EMPTY; METAL CARBON DIOXIDE GAS CYLINDERS SOLD EMPTY FOR USE WITH GAS GUNS; METAL CONTAINERS IN THE NATURE OF CARBON DIOXIDE GAS CARTRIDGES SOLD EMPTY; METAL CONTAINERS IN THE NATURE OF CARBON DIOXIDE CARTRIDGES SOLD EMPTY FOR USE WITH GAS GUNS; REPLACEMENT PARTS AND FITTINGS FOR THE AFORESAID GOODS (U.S. CLS. 2, 12, 13, 14, 23, 25 AND 50).

CLASS 7—MACHINERY

FOR ELECTRIC APPLIANCES FOR MAKING AERATED AND CARBONATED BEVERAGES, NAMELY, MIXERS; MACHINES FOR MAKING AERATED AND CARBONATED BEVERAGES; ELECTRIC, HYDRAULIC AND PNEUMATIC AIR DELIVERY VALVE GUNS; ELECTRIC, HYDRAULIC AND PNEUMATIC GAS DELIVERY VALVE GUNS; ELECTRIC, HYDRAULIC AND PNEUMATIC CARBON DIOXIDE DELIVERY VALVE GUNS; ELECTRIC, HYDRAULIC AND PNEUMATIC VALVE GUNS FOR USE WITH ELECTRIC MACHINES FOR MAKING AERATED AND CARBONATED BEVERAGES; APPARATUS FOR FILLING GAS IN BOTTLES, NAMELY, FILLING MACHINES; HYDRAULIC AEROSOL ACTUATORS; AND REPLACEMENT PARTS AND FITTINGS FOR THE AFORESAID GOODS (U.S. CLS. 13, 19, 21, 23, 31, 34 AND 35).

CLASS 21—HOUSEWARES AND GLASS

FOR BOTTLES SOLD EMPTY; AEROSOL BOTTLES SOLD EMPTY; NON-METAL CAPS AND LIDS FOR BOTTLES; GLASS STOPPERS FOR BOTTLES; NON-METAL LIDS FOR BOTTLES DESIGNED TO MAINTAIN AERATION AND CARBONATION OF BEVERAGES; NON-ELECTRIC DOMESTIC AND KITCHEN APPLIANCES AND MACHINES FOR MAKING AERATED AND CARBONATED BEVERAGES, NAMELY, BEVERAGE WHISKS AND FROTHERS FOR HOUSEHOLD USE; REPLACEMENT PARTS AND FITTINGS FOR THE AFORESAID GOODS (U.S. CLS. 2, 13, 23, 29, 30, 33, 40 AND 50).

TRACY FLETCHER, EXAMINING ATTORNEY

SN 77-962,062. 4 THOUGHT ENERGY LLC, DEERFIELD, IL. FILED 3-18-2010.

4 THOUGHT ENERGY

THE MARK CONSISTS OF STANDARD CHARACTERS WITHOUT CLAIM TO ANY PARTICULAR FONT, STYLE, SIZE, OR COLOR.

NO CLAIM IS MADE TO THE EXCLUSIVE RIGHT TO USE "ENERGY", APART FROM THE MARK AS SHOWN.

CLASS 35—ADVERTISING AND BUSINESS

FOR OPERATION AND MANAGEMENT OF DISTRIBUTED ENERGY SYSTEMS FOR OTHERS; ENERGY BILL MANAGEMENT SERVICES, NAMELY, TRACKING, REPORTING, ANALYZING, AND DELIVERING ENERGY INFORMATION IN THE FORM OF ENERGY BILLS FOR DISTRIBUTED ENERGY SYSTEMS; ENERGY PROVIDER SERVICES, NAMELY, PROVIDING A SERVICE THAT ALLOWS CUSTOMERS TO PURCHASE ENERGY THROUGH A DISTRIBUTED ENERGY SYSTEM (U.S. CLS. 100, 101 AND 102).

CLASS 37—CONSTRUCTION AND REPAIR

FOR INSTALLATION, REPAIR, AND MAINTENANCE OF DISTRIBUTED ENERGY SYSTEMS FOR OTHERS (U.S. CLS. 100, 103 AND 106).

CLASS 39—TRANSPORTATION AND STORAGE

FOR DISTRIBUTION OF ENERGY FOR OTHERS BY USING DISTRIBUTED ENERGY SYSTEMS (U.S. CLS. 100 AND 105).

CLASS 40—MATERIAL TREATMENT

FOR CONSULTING SERVICES IN THE FIELD OF DISTRIBUTED ENERGY SYSTEMS, NAMELY, CONSULTING REGARDING THE PRODUCTION OF ENERGY BY DISTRIBUTED ENERGY SYSTEMS; PRODUCTION OF ENERGY BY DISTRIBUTED ENERGY SYSTEMS (U.S. CLS. 100, 103 AND 106).

FIRST USE 9-29-2009; IN COMMERCE 9-29-2009.

CLASS 42—SCIENTIFIC AND COMPUTER SERVICES

FOR DESIGN OF DISTRIBUTED ENERGY SYSTEMS FOR OTHERS; CONSULTING SERVICES IN THE FIELD OF DISTRIBUTED ENERGY SYSTEMS, NAMELY, CONSULTING REGARDING DESIGN OF DISTRIBUTED ENERGY SYSTEMS (U.S. CLS. 100 AND 101).

FIRST USE 9-29-2009; IN COMMERCE 9-29-2009.

EUGENIA MARTIN, EXAMINING ATTORNEY

CLASS 9—ELECTRICAL AND SCIENTIFIC APPARATUS

FOR LABORATORY CHEMICAL REACTORS; LABORATORY EQUIPMENT, NAMELY, LABORATORY STAINERS, VIALS, CASSETTES, COVERSLIPS, COVERSLIP ROLLS, FORMALIN CONTAINERS, AND FILTERS FOR ABSORPTION OF TOXIC CHEMICALS FROM GASEOUS MEDIUM, AND REMOVAL OF MATERIAL EMPLOYING MICRO-SCREENS; LABORATORY APPARATUS, NAMELY, EXTRACTIVE VAPORIZATION PROCESSORS FOR TISSUE PROCESSING, FOR HISTOLOGY, PATHOLOGY, MOLECULAR PATHOLOGY CYTOGENETIC AND SCIENTIFIC RESEARCH; ALDEHYDE CONTROL EQUIPMENT, NAMELY, CHEMICAL PROCESSING EQUIPMENT FOR THE DETOXIFICATION OF HAZARDOUS WASTE, REACTOR TANKS, AND ABSORPTION SYSTEMS; IMMERSION COOLERS, RECIRCULATING CHILLERS AND WATER PURIFIERS, ALL FOR LABORATORY USE; CENTRIFUGES FOR LABORATORY USE; SLIDE PREPARATION EQUIPMENT, NAMELY, APPLICATORS, COVER SLIPPING APPLICATORS, AND REAGENT DISPENSERS, FOR MANUFACTURING OF SPECIMEN SLIDES; AND EXTRACTIVE VAPORIZATION PROCESSORS FOR TISSUE PRESERVATION AND PROCESSING FOR HISTOLOGY, PATHOLOGY, MOLECULAR PATHOLOGY CYTOGENETIC, PHARMACEUTICAL DEVELOPMENT, AND SCIENTIFIC RESEARCH FOR LABORATORY USE (U.S. CLS. 21, 23, 26, 36 AND 38).

FIRST USE 1-0-2010; IN COMMERCE 1-0-2010.

CLASS 42—SCIENTIFIC AND COMPUTER SERVICES

FOR CHEMISTRY CONSULTATION; CONSULTING IN THE FIELD OF ENGINEERING; CONSULTING IN THE FIELD OF LABORATORY DIAGNOSTICS CONCERNING LABORATORY EQUIPMENT AND LABORATORY APPARATUS (U.S. CLS. 100 AND 101).

FIRST USE 1-0-1993; IN COMMERCE 1-0-1993.

CLASS 44—MEDICAL, BEAUTY AND AGRICULTURAL SERVICES

FOR CONSULTING SERVICES IN THE FIELD OF MEDICAL CARE CONCERNING MEDICAL EQUIPMENT AND MEDICAL APPARATUSES (U.S. CLS. 100 AND 101).

FIRST USE 1-0-1993; IN COMMERCE 1-0-1993.

MICHELE SWAIN, EXAMINING ATTORNEY

SN 77-962,133. SCI GEN, INC., GARDENA, CA. FILED 3-18-2010.



The logo for Scigen features the word "Scigen" in a stylized, cursive font. The letters are black with a slight shadow effect. Below the text is a thick, grey, swoosh-like arc that curves under the word, starting from the left and ending on the right.

THE MARK CONSISTS OF THE LITERAL ELEMENT OF THE MARK, IN STYLIZED LETTERING, WITH A SWOOSH-LIKE SYMBOL UNDERNEATH.

CLASS 1—CHEMICALS

FOR DIAGNOSTIC PREPARATIONS FOR CLINICAL OR MEDICAL LABORATORY USE; DIAGNOSTIC REAGENTS FOR CLINICAL OR MEDICAL LABORATORY USE; REAGENTS FOR SCIENTIFIC OR MEDICAL RESEARCH USE; CHEMICALS FOR TREATING HAZARDOUS WASTE (U.S. CLS. 1, 5, 6, 10, 26 AND 46).

FIRST USE 1-0-1993; IN COMMERCE 1-0-1993.

CLASS 5—PHARMACEUTICALS

FOR MEDICAL DIAGNOSTIC REAGENTS, NAMELY, HISTOLOGY REAGENTS AND PATHOLOGY REAGENTS (U.S. CLS. 6, 18, 44, 46, 51 AND 52).

FIRST USE 1-0-1993; IN COMMERCE 1-0-1993.

SN 77-966,186. BARRY WRIGHT CORP., HOPKINTON, MA. FILED 3-23-2010.



The logo for HI-DAMP consists of the words "HI-DAMP" in a bold, serif, all-caps font. The letters are black and have a slightly distressed or textured appearance.

THE MARK CONSISTS OF STANDARD CHARACTERS WITHOUT CLAIM TO ANY PARTICULAR FONT, STYLE, SIZE, OR COLOR.

CLASS 9—ELECTRICAL AND SCIENTIFIC APPARATUS

FOR MOUNTING DEVICES FOR SHIPBOARD ELECTRONICS TO BE USED IN MINIMIZING, ABSORBING AND ISOLATING VIBRATION, SHOCK, AND OR NOISE; MOUNTING DEVICES FOR RACKING SYSTEMS TO BE USED IN MINIMIZING, ABSORBING AND ISOLATING VIBRATION, SHOCK, AND OR NOISE; MOUNTING DEVICES FOR AIRCRAFT AND MOBILE APPLICATIONS TO BE USED IN MINIMIZING, ABSORBING AND ISOLATING VIBRATION, SHOCK, AND OR NOISE; MOUNTING DEVICES FOR RUGGEDIZED DISK DRIVES TO BE USED IN MINIMIZING, ABSORBING AND ISOLATING VIBRATION, SHOCK, AND OR NOISE; MOUNTING DEVICES FOR AVIONICS AND ELECTRONICS TO BE USED IN MINIMIZING, ABSORBING AND ISOLATING VIBRATION, SHOCK, AND OR NOISE; MOUNTING DEVICES FOR INSTRUMENT PANELS TO BE USED IN MINIMIZING, ABSORBING AND ISOLATING VIBRATION, SHOCK, AND OR NOISE; MOUNTING DEVICES FOR PUMPS USED IN CONNECTION WITH FLUID TRANSFER SYSTEMS FOR THE TRANSMISSION OF POTABLE AND NON-POTABLE WATER, CHEMICALS, COOLANTS, AND PETROLEUM-BASED FUELS, OILS AND LUBRICANTS, TO BE USED IN MINIMIZING, ABSORBING AND ISOLATING VIBRATION, SHOCK, AND OR NOISE; MOUNTING DEVICES FOR MISSILE ELECTRONICS TO BE USED IN MINIMIZING, ABSORBING AND ISOLATING VIBRATION, SHOCK, AND OR NOISE; MOUNTING DEVICES FOR MOTORS AND GENERATORS TO BE USED IN MINIMIZING, ABSORBING AND ISOLATING VIBRATION, SHOCK, AND OR NOISE; MOUNTING DEVICES FOR AIRBORNE ELECTRONICS AND RACKING TO BE USED IN MINIMIZING, ABSORBING AND ISOLATING VIBRATION, SHOCK, AND OR NOISE; MOUNTING DEVICES FOR SEVERE RANDOM VIBRATION ENVIRONMENTS TO BE USED IN MINIMIZING, ABSORBING AND ISOLATING VIBRATION, SHOCK, AND OR NOISE; MOUNTING DEVICES FOR OXYGEN CONCENTRATORS TO BE USED IN MINIMIZING, ABSORBING AND ISOLATING VIBRATION, SHOCK, AND OR NOISE; MOUNTING DEVICES FOR COMPRESSORS TO BE USED IN MINIMIZING, ABSORBING AND ISOLATING VIBRATION, SHOCK, AND OR NOISE; MOUNTING DEVICES FOR ELECTRONIC EQUIPMENT TO BE USED IN MINIMIZING, ABSORBING AND ISOLATING VIBRATION, SHOCK, AND OR NOISE; MOUNTING DEVICES FOR ELECTRONIC CHASSIS TO BE USED IN MINIMIZING, ABSORBING AND ISOLATING VIBRATION, SHOCK, AND OR NOISE; MOUNTING DEVICES FOR ELECTROMECHANICAL EQUIPMENT TO BE USED IN MINIMIZING, ABSORBING AND ISOLATING VIBRATION, SHOCK, AND OR NOISE; MOUNTING DEVICES FOR APPLIANCES TO BE USED IN MINIMIZING, ABSORBING AND ISOLATING VIBRATION, SHOCK, AND OR NOISE; MOUNTING DEVICES FOR OFFICE EQUIPMENT TO BE USED IN MINIMIZING, ABSORBING AND ISOLATING VIBRATION, SHOCK, AND OR NOISE; MOUNTING DEVICES FOR ELECTRONICS FOR ROTARY WING AND PROPELLER DRIVEN AIRCRAFT TO BE USED IN MINIMIZING, ABSORBING AND ISOLATING VIBRATION, SHOCK, AND OR NOISE; MOUNTING DEVICES FOR MOBILE GROUND EQUIPMENT TO BE USED IN MINIMIZING, ABSORBING AND ISOLATING VIBRATION, SHOCK, AND OR NOISE; MOUNTING DEVICES FOR SHIPPING CONTAINERS TO BE USED IN MINIMIZING, ABSORBING AND ISOLATING VIBRATION, SHOCK, AND OR NOISE; MOUNTING DEVICES FOR SHIPBOARD EQUIPMENT TO BE USED IN MINIMIZING, ABSORBING AND ISOLATING VIBRATION, SHOCK, AND OR NOISE; MOUNTING DEVICES FOR MOBILE MOUNTED EQUIPMENT TO BE USED IN MINIMIZING, ABSORBING AND ISOLATING VIBRATION, SHOCK, AND OR NOISE; MOUNTING DEVICES FOR ELECTRONIC EQUIPMENT IN HELICOPTER ENVIRONMENTS TO BE USED IN MINIMIZING, ABSORBING AND ISOLATING VIBRATION, SHOCK, AND OR NOISE (U.S. CLS. 21, 23, 26, 36 AND 38).

CLASS 10—MEDICAL APPARATUS

FOR MOUNTING DEVICES FOR MEDICAL EQUIPMENT TO BE USED IN MINIMIZING, ABSORBING AND ISOLATING VIBRATION, SHOCK, AND OR NOISE (U.S. CLS. 26, 39 AND 44).

CLASS 12—VEHICLES

FOR MOUNTING DEVICES FOR MOTORS AND GENERATORS TO BE USED IN MINIMIZING, ABSORBING AND ISOLATING VIBRATION, SHOCK, AND OR NOISE; MOUNTING DEVICES FOR GROUND TRANSPORTATION APPLICATIONS TO BE USED IN MINIMIZING, ABSORBING AND ISOLATING VIBRATION, SHOCK, AND OR NOISE; MOUNTING DEVICES FOR ELECTRIC MOTORS TO BE USED IN MINIMIZING, ABSORBING AND ISOLATING VIBRATION, SHOCK, AND OR NOISE (U.S. CLS. 19, 21, 23, 31, 35 AND 44).
ANNE E. GUSTASON, EXAMINING ATTORNEY

SN 77-966,346. SEALS UNLIMITED, INC., HILLSBORO, OR.
FILED 3-23-2010.



THE MARK CONSISTS OF A CARTOON DRAWING OF A SEAL (ANIMAL) HOLDING AN OCTAGONAL SEAL ON THE TIP OF ITS NOSE.

CLASS 17—RUBBER GOODS

FOR MOLDED RUBBER PRODUCTS, NAMELY, RUBBER GATE SEALS FOR USE IN WATER DAMS, WATER LOCKS, WATER WORKS, IRRIGATION, FISH MITIGATION, FLOOD PROTECTION, AND POWER GENERATION PROJECTS; EXTRUDED RUBBER PRODUCTS, NAMELY, RUBBER GATE SEALS FOR USE IN WATER DAM, WATER LOCKS, WATER WORKS, IRRIGATION, FISH MITIGATION, FLOOD PROTECTION AND POWER GENERATION PROJECTS; NON-METAL GASKETS, NAMELY, GASKETS MADE FROM SHEET RUBBER, PLASTIC, SPONGE, CORK AND FELT, FOR USE IN HYDRO, FISH MITIGATION, WASTE WATER, POWER GENERATION, FOOD AND BEVERAGE, TRUCKING, AGRICULTURE, MARINE, MANUFACTURING, AND PULP AND PAPER PROJECTS, OTHER THAN GASKETS FOR ENGINES (U.S. CLS. 1, 5, 12, 13, 35 AND 50).

FIRST USE 8-7-1987; IN COMMERCE 8-7-1987.

CLASS 37—CONSTRUCTION AND REPAIR

FOR RUBBER TO METAL BONDING, NAMELY, APPLYING METALS TO PORTIONS OF MOLDED AND EXTRUDED RUBBER PRODUCTS, FOR OTHERS; RUBBER TO TEFLON BONDING, NAMELY, APPLYING TEFLON TO PORTIONS OF MOLDED AND EXTRUDED RUBBER PRODUCTS, FOR OTHERS; VULCANIZING, NAMELY, HEAT AND PRESSURE TREATMENT OF MOLDED AND EXTRUDED RUBBER PRODUCTS AND JOINING MOLDED AND EXTRUDED RUBBER PRODUCTS TO OTHER MOLDED AND EXTRUDED RUBBER PRODUCTS THROUGH A HEAT AND PRESSURE PROCESS, FOR OTHERS; STRIPPING RUBBER MATERIALS FOR OTHERS (U.S. CLS. 100, 103 AND 106).

FIRST USE 8-7-1987; IN COMMERCE 8-7-1987.

CLASS 40—MATERIAL TREATMENT

FOR CUTTING AND SPLICING RUBBER MATERIALS FOR OTHERS (U.S. CLS. 100, 103 AND 106).
FIRST USE 8-7-1987; IN COMMERCE 8-7-1987.
LINDA M. KING, EXAMINING ATTORNEY

CLASS 20—FURNITURE AND ARTICLES NOT OTHERWISE CLASSIFIED

FOR STUFFED ANIMALS AND MIRRORS; CLEAR PLASTIC HOLDERS FOR BADGES; PLASTIC NAME BADGES (U.S. CLS. 2, 13, 22, 25, 32 AND 50).
FIRST USE 12-31-1994; IN COMMERCE 12-31-1994.

SN 77-966,652. CALIFORNIA TEACHERS ASSOCIATION,
BURLINGAME, CA. FILED 3-23-2010.

CTA

THE MARK CONSISTS OF STANDARD CHARACTERS WITHOUT CLAIM TO ANY PARTICULAR FONT, STYLE, SIZE, OR COLOR.

CLASS 6—METAL GOODS

FOR METAL KEY RINGS (U.S. CLS. 2, 12, 13, 14, 23, 25 AND 50).
FIRST USE 12-31-2009; IN COMMERCE 12-31-2009.

CLASS 9—ELECTRICAL AND SCIENTIFIC APPARATUS

FOR ELECTRONIC DIGITAL CALCULATORS, PRE-RECORDED DIGITAL MEDIA IN THE FIELD OF EDUCATIONAL INSTRUCTION, CREDIT CARDS WITH MAGNETIC STRIPS AND RULERS, NAMELY, GRADUATED RULERS AND TAPE RULERS, AND LAPTOP COMPUTER CARRYING CASES NOT MADE OF LEATHER (U.S. CLS. 21, 23, 26, 36 AND 38).
FIRST USE 12-31-1998; IN COMMERCE 12-31-1998.

CLASS 11—ENVIRONMENTAL CONTROL APPARATUS

FOR PEN LIGHTS (U.S. CLS. 13, 21, 23, 31 AND 34).
FIRST USE 12-31-1998; IN COMMERCE 12-31-1998.

CLASS 14—JEWELRY

FOR LAPEL PINS AND CLOCKS (U.S. CLS. 2, 27, 28 AND 50).
FIRST USE 12-31-1990; IN COMMERCE 12-31-1990.

CLASS 16—PAPER GOODS AND PRINTED MATTER

FOR PENS, PENCILS, BOOKMARKS, PAPERCLIP HOLDERS, STAPLERS, CALENDARS; BOOKS, NAMELY, APPOINTMENT BOOKS, EDUCATIONAL BOOKS IN THE FIELD OF EDUCATION, BOOKLETS AND MAGAZINES IN THE FIELD OF EDUCATION AND LOCAL TEACHER ORGANIZATION SUPPORT AND GOVERNANCE, NEWSPAPERS, PRINTED AWARDS, PRINTED CERTIFICATES, AND PAPER NAME BADGES (U.S. CLS. 2, 5, 22, 23, 29, 37, 38 AND 50).
FIRST USE 12-31-1957; IN COMMERCE 12-31-1957.

CLASS 18—LEATHER GOODS

FOR LUGGAGE AND BRIEFCASE TAGS AND DUFFLE AND TOTE BAGS NOT MADE OF LEATHER (U.S. CLS. 1, 2, 3, 22 AND 41).
FIRST USE 12-31-1989; IN COMMERCE 12-31-1989.

CLASS 21—HOUSEWARES AND GLASS

FOR BOTTLE OPENERS; MUGS, EMPTY PLASTIC WATER BOTTLES, AND INSULATED FOOD BAGS NOT MADE OF LEATHER FOR DOMESTIC USE (U.S. CLS. 2, 13, 23, 29, 30, 33, 40 AND 50).
FIRST USE 12-31-1989; IN COMMERCE 12-31-1989.

CLASS 22—CORDAGE AND FIBERS

FOR LANYARDS FOR HOLDING BADGES (U.S. CLS. 1, 2, 7, 19, 22, 42 AND 50).
FIRST USE 12-31-2009; IN COMMERCE 12-31-2009.

CLASS 25—CLOTHING

FOR T-SHIRTS, POLO SHIRTS AND SUN VISORS (U.S. CLS. 22 AND 39).
FIRST USE 12-31-1989; IN COMMERCE 12-31-1989.

CLASS 26—FANCY GOODS

FOR ORNAMENTAL NOVELTY BADGES (U.S. CLS. 37, 39, 40, 42 AND 50).
FIRST USE 12-31-2000; IN COMMERCE 12-31-2000.

CLASS 32—LIGHT BEVERAGES

FOR BOTTLED WATER (U.S. CLS. 45, 46 AND 48).
FIRST USE 12-31-2001; IN COMMERCE 12-31-2001.

CLASS 35—ADVERTISING AND BUSINESS

FOR ASSOCIATION SERVICES, NAMELY, PROMOTING THE INTERESTS OF CALIFORNIA TEACHERS; ADMINISTRATION OF A CONSUMER DISCOUNT LOYALTY PROGRAM ENABLING MEMBERS TO OBTAIN DISCOUNTS ON GOODS AND SERVICES, NAMELY, NEW AND USED VEHICLES, HOTEL AND MOTEL SERVICES, MOVIE THEATERS, MUSEUMS AND AMUSEMENT PARKS; ADMINISTERING DISCOUNT GROUP PURCHASING PROGRAMS, NAMELY, NEGOTIATING CONTRACTS WITH PROVIDERS OF INSURANCE SERVICES IN THE FIELD OF LIFE, DISABILITY, DEATH, DISMEMBERMENT, HOME, AND AUTOMOBILE LIABILITY, TO ENABLE PARTICIPANT MEMBERS OF A TEACHERS ASSOCIATION TO OBTAIN DISCOUNTS ON THE PURCHASE OF THE INSURANCE SERVICES OF OTHERS THROUGH THE USE OF ASSOCIATION MEMBERSHIP (U.S. CLS. 100, 101 AND 102).
FIRST USE 12-31-1907; IN COMMERCE 12-31-1907.

CLASS 36—INSURANCE AND FINANCIAL

FOR FINANCIAL SERVICES, NAMELY, CREDIT UNION SERVICES; PROVIDING EDUCATIONAL SCHOLARSHIPS (U.S. CLS. 100, 101 AND 102).
FIRST USE 12-31-1952; IN COMMERCE 12-31-1952.

CLASS 41—EDUCATION AND ENTERTAINMENT

FOR EDUCATIONAL SERVICES, NAMELY CONDUCTING SEMINARS AND CONFERENCES ON TOPICS OF INTEREST TO TEACHERS, NAMELY, DEVELOPING CURRICULUM FOR TEACHERS; PROVIDING RECOGNITION BY THE WAY OF AWARD CERTIFICATES TO DEMONSTRATE EXCELLENCE IN THE FIELDS OF TEACHING, DIVERSITY, COMMUNICATIONS AND ACTIVITIES SUPPORTING FOR LOCAL TEACHER ORGANIZATIONS; EDUCATIONAL SERVICES, NAMELY CONDUCTING TELEPHONIC EDUCATIONAL INSTRUCTION IN THE FIELDS OF HEALTH AND WELLNESS; OPERATING A WEBSITE ON THE WORLDWIDE WEB CONTAINING INFORMATION OF INTEREST TO TEACHERS, NAMELY, PROVISION OF INFORMATION RELATING TO EDUCATIONAL SERVICES AND INFORMATION ABOUT EDUCATION (U.S. CLS. 100, 101 AND 107).

FIRST USE 12-31-1941; IN COMMERCE 12-31-1941.
JANICE KIM, EXAMINING ATTORNEY

SN 77-967,738. UNISEN, INC., IRVINE, CA. FILED 3-24-2010.

STAR TRAC COACH

THE MARK CONSISTS OF STANDARD CHARACTERS WITHOUT CLAIM TO ANY PARTICULAR FONT, STYLE, SIZE, OR COLOR.

NO CLAIM IS MADE TO THE EXCLUSIVE RIGHT TO USE "COACH", APART FROM THE MARK AS SHOWN.

CLASS 9—ELECTRICAL AND SCIENTIFIC APPARATUS

FOR COMPUTER SOFTWARE, NAMELY, COMPUTER SOFTWARE FOR USE WITH EXERCISE MACHINES THAT PROVIDES A VIDEO WORKOUT (U.S. CLS. 21, 23, 26, 36 AND 38).

CLASS 28—TOYS AND SPORTING GOODS

FOR EXERCISE MACHINES AND EQUIPMENT, NAMELY, TREADMILLS, ELLIPTICALS, STEP MACHINES, BICYCLES, AND STRENGTH AND WEIGHTLIFTING EQUIPMENT (U.S. CLS. 22, 23, 38 AND 50).

ALICE BENMAMAN, EXAMINING ATTORNEY

SN 77-968,565. RSA 1 LIMITED PARTNERSHIP, EMERSON, IA. AND IOWA RSA 2 LIMITED PARTNERSHIP, EMERSON, IA. FILED 3-25-2010.



NO CLAIM IS MADE TO THE EXCLUSIVE RIGHT TO USE "CHAT MOBILITY", APART FROM THE MARK AS SHOWN.

THE COLOR(S) GREEN AND BLACK IS/ARE CLAIMED AS A FEATURE OF THE MARK.

THE MARK CONSISTS OF A GREEN SPHERE WITH A CARTOON OF THE UPPER TORSO AND HEAD OF TWO PEOPLE, ONE LARGER THAN THE OTHER, IN BLACK, WITH THE WORDS "CHAT MOBILITY." IN BLACK.

CLASS 9—ELECTRICAL AND SCIENTIFIC APPARATUS

FOR CELLULAR TELEPHONE APPARATUSES; CELLULAR TELEPHONES; DIGITAL TELEPHONES; MOBILE TELEPHONES; PORTABLE TELEPHONES; TELEPHONE APPARATUS; TELEPHONES; WIRELESS TELEPHONES (U.S. CLS. 21, 23, 26, 36 AND 38).

FIRST USE 3-24-2010; IN COMMERCE 3-24-2010.

CLASS 38—COMMUNICATION

FOR CELLULAR TELEPHONE COMMUNICATION; CELLULAR TELEPHONE SERVICES; COMMUNICATION BY MOBILE TELEPHONE; COMMUNICATIONS BY TELEPHONE; FIXED AND MOBILE TELEPHONE SERVICES; LOCAL AND LONG DISTANCE TELEPHONE SERVICES; MOBILE TELEPHONE COMMUNICATION; MOBILE TELEPHONE SERVICES; PROVIDING TELEPHONE CONFERENCING SERVICES; TELECOMMUNICATION SERVICES IN THE NATURE OF PROVIDING TELEPHONE FEATURES, NAMELY, CALL WAITING, CALL IDENTIFICATION, CALL FORWARDING, AND MESSAGE WAITING; TELEPHONE COMMUNICATIONS; TELEPHONE VOICE MESSAGING SERVICES; WIRELESS TELEPHONE TELECOMMUNICATIONS SERVICES, NAMELY, WIRELESS MOBILE TELEPHONE CALLING PLANS (U.S. CLS. 100, 101 AND 104).

FIRST USE 3-24-2010; IN COMMERCE 3-24-2010.

MORGAN WYNNE, EXAMINING ATTORNEY

SN 77-969,079. GILLESPIE JASON, CALGARY, ALBERTA, CANADA, FILED 3-26-2010.

FLU GOO

THE MARK CONSISTS OF STANDARD CHARACTERS WITHOUT CLAIM TO ANY PARTICULAR FONT, STYLE, SIZE, OR COLOR.

NO CLAIM IS MADE TO THE EXCLUSIVE RIGHT TO USE "FLU", APART FROM THE MARK AS SHOWN.

CLASS 1—CHEMICALS

FOR CHEMICAL AGENTS FOR THE USE IN THE MANUFACTURE OF HAND SANITIZING PREPARATIONS AND CHEMICAL AGENTS FOR THE USE IN THE MANUFACTURE OF COLORED HAND SANITIZING PREPARATIONS FOR PARENTS, CHILDREN, TEENAGERS, AND CONSUMERS OF ALL AGES (U.S. CLS. 1, 5, 6, 10, 26 AND 46).

CLASS 5—PHARMACEUTICALS

FOR PHARMACEUTICAL PRODUCTS, NAMELY, SANITIZING PREPARATIONS FOR HOUSEHOLD USE AND COLORED HAND SANITIZING PREPARATIONS FOR HOUSEHOLD USE FOR PARENTS, CHILDREN, TEENAGERS, AND CONSUMERS OF ALL AGES (U.S. CLS. 6, 18, 44, 46, 51 AND 52).

NAPOLÉON SHARMA, EXAMINING ATTORNEY

SN 77-969,547. MICRO CARE CORPORATION, NEW BRITAIN, CT. FILED 3-26-2010.

SN 77-969,810. DESTINY HEALTH, INC., CHICAGO, IL. FILED 3-26-2010.



THE MARK CONSISTS OF DESIGN MARK IN A CIRCULAR SWIRL PATTERN.

CLASS 1—CHEMICALS

FOR CHEMICAL PREPARATIONS, NAMELY, DEGREASING, CLEANING AND FLUX REMOVAL SOLVENTS FOR THE MEDICAL DEVICES, ELECTRONICS, OPTICS AND AEROSPACE INDUSTRIES (U.S. CLS. 1, 5, 6, 10, 26 AND 46).

FIRST USE 2-9-2010; IN COMMERCE 2-25-2010.

CLASS 4—LUBRICANTS AND FUELS

FOR LUBRICANTS BASED ON POLYTETRAFLUOROETHYLENE FOR USE ON MEDICAL DEVICES AND IN THE MANUFACTURE THEREOF (U.S. CLS. 1, 6 AND 15).

FIRST USE 2-9-2010; IN COMMERCE 2-25-2010.
BARBARA RUTLAND, EXAMINING ATTORNEY

SN 77-969,612. MICRO CARE CORPORATION, NEW BRITAIN, CT. FILED 3-26-2010.

MICROCARE MEDICAL

THE MARK CONSISTS OF STANDARD CHARACTERS WITHOUT CLAIM TO ANY PARTICULAR FONT, STYLE, SIZE, OR COLOR.

OWNER OF U.S. REG. NOS. 1,127,376, 1,706,094 AND 3,443,787.

NO CLAIM IS MADE TO THE EXCLUSIVE RIGHT TO USE "MEDICAL", APART FROM THE MARK AS SHOWN.

CLASS 1—CHEMICALS

FOR CHEMICAL PREPARATIONS, NAMELY, DEGREASING, CLEANING AND FLUX REMOVAL SOLVENTS FOR THE MEDICAL DEVICES, ELECTRONICS, OPTICS AND AEROSPACE INDUSTRIES (U.S. CLS. 1, 5, 6, 10, 26 AND 46).

FIRST USE 2-9-2010; IN COMMERCE 2-25-2010.

CLASS 4—LUBRICANTS AND FUELS

FOR LUBRICANTS BASED ON POLYTETRAFLUOROETHYLENE FOR USE ON MEDICAL DEVICES AND IN THE MANUFACTURE THEREOF (U.S. CLS. 1, 6 AND 15).

FIRST USE 2-9-2010; IN COMMERCE 2-25-2010.
BARBARA RUTLAND, EXAMINING ATTORNEY

VITALITY STATUS

THE MARK CONSISTS OF STANDARD CHARACTERS WITHOUT CLAIM TO ANY PARTICULAR FONT, STYLE, SIZE, OR COLOR.

OWNER OF U.S. REG. NOS. 2,800,989, 3,381,251 AND OTHERS.

CLASS 35—ADVERTISING AND BUSINESS

FOR PROVIDING ASSISTANCE, FITNESS EVALUATION AND CONSULTATION TO BUSINESSES TO HELP THEIR EMPLOYEES MAKE HEALTH, WELLNESS AND NUTRITIONAL CHANGES IN THEIR DAILY LIVING TO INCREASE PRODUCTIVITY AND LOWER HEALTH CARE COSTS (U.S. CLS. 100, 101 AND 102).

CLASS 42—SCIENTIFIC AND COMPUTER SERVICES

FOR APPLICATION SERVICE PROVIDER, NAMELY, PROVIDING, HOSTING, MANAGING, DEVELOPING, RESEARCHING, ANALYZING, REPORTING, AND MAINTAINING APPLICATIONS, SOFTWARE AND DATABASES FOR OTHERS IN THE FIELDS OF EMPLOYEE HEALTH INSURANCE AND WELLNESS PROGRAMS (U.S. CLS. 100 AND 101).

ALYSSA STEEL, EXAMINING ATTORNEY

SN 77-969,834. DESTINY HEALTH, INC., CHICAGO, IL. FILED 3-26-2010.

OWNER OF U.S. REG. NOS. 2,800,989, 3,381,251 AND OTHERS.

THE MARK CONSISTS OF THE WORD "VITALITY" IN STYLIZED FORM.

CLASS 35—ADVERTISING AND BUSINESS

FOR PROVIDING ASSISTANCE, FITNESS EVALUATION AND CONSULTATION TO BUSINESSES TO HELP THEIR EMPLOYEES MAKE HEALTH, WELLNESS AND NUTRITIONAL CHANGES IN THEIR DAILY LIVING TO INCREASE PRODUCTIVITY AND LOWER HEALTH CARE COSTS (U.S. CLS. 100, 101 AND 102).

CLASS 36—INSURANCE AND FINANCIAL

FOR INSURANCE SERVICES, NAMELY, ADMINISTRATION OF HEALTH INSURANCE (U.S. CLS. 100, 101 AND 102).

CLASS 42—SCIENTIFIC AND COMPUTER SERVICES

FOR APPLICATION SERVICES PROVIDER, NAMELY, PROVIDING, HOSTING, MANAGING, DEVELOPING, RESEARCHING, ANALYZING, REPORTING, AND MAINTAINING APPLICATIONS, SOFTWARE AND DATABASES FOR OTHERS IN THE FIELDS OF EMPLOYEE HEALTH INSURANCE AND WELLNESS PROGRAMS (U.S. CLS. 100 AND 101).

ALYSSA STEEL, EXAMINING ATTORNEY

CLASS 31—NATURAL AGRICULTURAL PRODUCTS

FOR NON-MEDICAL ADDITIVES TO FODDER; OIL CAKE FOR ANIMAL CONSUMPTION; CATTLE FOOD; FODDER; YEAST FOR ANIMAL CONSUMPTION, NOT FOR MEDICAL OR VETERINARY PURPOSES; MAIZE CAKE FOR CATTLE; FOOD FOR ANIMALS; PROTEIN FOR ANIMAL CONSUMPTION; CEREAL BY-PRODUCTS FOR ANIMAL CONSUMPTION; EDIBLE CHEWS FOR ANIMALS (U.S. CLS. 1 AND 46).

JOHN WILKE, EXAMINING ATTORNEY

SN 78-540,939. CHANGCHUN DACHENG INDUSTRY GROUP CO., LTD., CHANGCHUN CITY, CHINA, FILED 1-3-2005.



PRIORITY CLAIMED UNDER SEC. 44(D) ON CHINA APPLICATION NO. 4161482, FILED 7-9-2004, REG. NO. 4161482, DATED 10-21-2006, EXPIRES 10-20-2016.

PRIORITY CLAIMED UNDER SEC. 44(D) ON CHINA APPLICATION NO. 4161483, FILED 7-9-2004, REG. NO. 4161483, DATED 10-21-2006, EXPIRES 10-20-2016.

PRIORITY CLAIMED UNDER SEC. 44(D) ON CHINA APPLICATION NO. 4161481, FILED 7-9-2004, REG. NO. 4161481, DATED 5-7-2007, EXPIRES 5-6-2017.

OWNER OF CHINA REG. NO. 4161963, DATED 7-14-2007, EXPIRES 7-13-2017.

THE MARK CONSISTS OF THE CHINESE CHARACTER CHENG IN THE MIDDLE OF A STAR DESIGN.

THE NON-LATIN CHARACTER(S) IN THE MARK TRANSLITERATES INTO CHENG, AND THIS MEANS ESTABLISHMENT IN ENGLISH.

CLASS 1—CHEMICALS

FOR ETHYL ALCOHOL; GLYCOL; BUTANOL; PROPYLENE GLYCOL; SORBITOL; STARCH FOR INDUSTRIAL PURPOSES, NAMELY, THE MANUFACTURE OF ENZYMES, FOODS AND PHARMACEUTICALS (U.S. CLS. 1, 5, 6, 10, 26 AND 46).

CLASS 5—PHARMACEUTICALS

FOR LYSINE PREPARATIONS; LYSINE HYDROCHLORATE FOR USE AS A NUTRITIONAL SUPPLEMENT; STARCH FOR DIETETIC OR PHARMACEUTICAL PURPOSES; AMINO ACIDS FOR MEDICAL PURPOSES; NUTRITIONAL ADDITIVES FOR MEDICAL PURPOSES (U.S. CLS. 6, 18, 44, 46, 51 AND 52).

CLASS 30—STAPLE FOODS

FOR STARCH FOR FOOD; STARCH PRODUCTS FOR FOOD; SEASONINGS; MONOSODIUM GLUTAMATE (U.S. CL. 46).

SN 78-937,142. CONCERT PHARMACEUTICALS, INC., BURLINGTON, MA. FILED 7-25-2006.

CoNCERT
Pharmaceuticals Inc.

NO CLAIM IS MADE TO THE EXCLUSIVE RIGHT TO USE "PHARMACEUTICALS INC.", APART FROM THE MARK AS SHOWN.

THE MARK CONSISTS OF THE WORD "CONCERT" WITH THE "O" IN LOWER CASE FORM AND THE "N" LARGER THAN THE OTHER UPPER CASE CHARACTERS WITH THE WORDS "PHARMACEUTICALS INC." APPEARING IN TITLE CASE BELOW "CONCERT".

CLASS 5—PHARMACEUTICALS

FOR PRESCRIPTION PHARMACEUTICAL AND BIOPHARMACEUTICAL PREPARATIONS, NAMELY, PHARMACEUTICAL PREPARATIONS FOR USE IN TREATING INFLAMMATORY DISEASES, INFECTIOUS DISEASES, CANCER AND CARDIOVASCULAR DISEASE (U.S. CLS. 6, 18, 44, 46, 51 AND 52).

CLASS 42—SCIENTIFIC AND COMPUTER SERVICES

FOR PHARMACEUTICAL RESEARCH AND DEVELOPMENT SERVICES (U.S. CLS. 100 AND 101).

KHANH LE, EXAMINING ATTORNEY

SN 79-065,833. PROMOTEC S.P.A., ITALY, FILED 12-9-2008.

FUTURMOTIVE

THE MARK CONSISTS OF STANDARD CHARACTERS WITHOUT CLAIM TO ANY PARTICULAR FONT, STYLE, SIZE, OR COLOR.

PRIORITY DATE OF 12-5-2008 IS CLAIMED.

OWNER OF INTERNATIONAL REGISTRATION 0994787 DATED 12-9-2008, EXPIRES 12-9-2018.

CLASS 35—ADVERTISING AND BUSINESS

FOR ORGANIZATION OF EXHIBITIONS FOR COMMERCIAL OR ADVERTISING PURPOSES, BUSINESS MANAGEMENT AND ORGANIZATION CONSULTANCY; ADVERTISING, PUBLIC RELATIONS (U.S. CLS. 100, 101 AND 102).

CLASS 41—EDUCATION AND ENTERTAINMENT

FOR ORGANIZATION OF EXHIBITIONS FOR CULTURAL OR EDUCATIONAL PURPOSES (U.S. CLS. 100, 101 AND 107).

CHARISMA HAMPTON, EXAMINING ATTORNEY

SN 79-071,174. FINE WHITE LINE LIMITED, NORTHAMPSHIRE, UNITED KINGDOM, FILED 5-27-2009.

SIR EDMUND HILLARY

THE MARK CONSISTS OF STANDARD CHARACTERS WITHOUT CLAIM TO ANY PARTICULAR FONT, STYLE, SIZE, OR COLOR.

PRIORITY DATE OF 11-28-2008 IS CLAIMED.

OWNER OF INTERNATIONAL REGISTRATION 1008397 DATED 5-27-2009, EXPIRES 5-27-2019.

THE NAME "SIR EDMUND HILLARY" DOES NOT IDENTIFY A LIVING INDIVIDUAL.

CLASS 9—ELECTRICAL AND SCIENTIFIC APPARATUS

FOR SCIENTIFIC, NAUTICAL, SURVEYING, PHOTOGRAPHIC, CINEMATOGRAPHIC, OPTICAL, WEIGHING, MEASURING, SIGNALING, CHECKING, SUPERVISION, LIFE-SAVING AND TEACHING APPARATUS AND INSTRUMENTS, NAMELY, OPTICAL MIRRORS, MARKER BUOYS, PHOTOGRAPHIC CAMERAS, CINEMATOGRAPHIC CAMERAS, TELESCOPES, WEIGHING SCALES, INSTRUMENTS FOR MEASURING LENGTH, SIGNALING BUOYS, AND LIFE SAVING RAFTS; APPARATUS AND INSTRUMENTS FOR CONDUCTING, SWITCHING, TRANSFORMING, ACCUMULATING, REGULATING OR CONTROLLING ELECTRICITY, NAMELY, ELECTRICAL SWITCHES, ELECTRIC TRANSFORMERS, ELECTRIC ACCUMULATORS, VOLTAGE REGULATORS FOR ELECTRIC POWER, ELECTRICAL CONTROLLERS; APPARATUS FOR RECORDING, TRANSMISSION OR REPRODUCTION OF SOUND OR IMAGES; AUTOMATIC VENDING MACHINES AND MECHANISMS FOR COIN OPERATED APPARATUS; FIRE-EXTINGUISHING APPARATUS; SOLAR PANELS IN THE NATURE OF APPARATUS FOR CONVERTING ELECTROMAGNETIC RADIATION TO ELECTRICAL ENERGY, NAMELY, PHOTOVOLTAIC SOLAR MODULES; RADIOS; EYEWEAR; SKI GOGGLES; SUNGLASSES; CASES FOR SUNGLASSES; CHAINS AND STRAPS FOR SUNGLASSES; MONOCULARS AND BINOCULARS; CASES ADAPTED FOR MONOCULARS AND BINOCULARS; ADAPTER PLUGS, NAMELY, TRAVEL ADAPTERS FOR ELECTRIC PLUGS; EAR PLUGS NOT FOR MEDICAL PURPOSES; TRAVEL GUIDES IN THE FORM OF AUDIO OR VIDEO RECORDINGS; Pedometers; COMPASSES; COMPUTER DIGITAL MAPS, NAMELY, DOWNLOADABLE DIGITAL MAPS AND DIGITAL MAPS STORED ON CDS AND DVDS; DISTANCE MEASURING APPARATUS, NAMELY, MAP MEASURING INSTRUMENTS; SIGNAL WHISTLES; WALKIE TALKIES; GLOBAL POSITIONING SYSTEMS (GPS) CONSISTING OF COMPUTERS, COMPUTER SOFTWARE, TRANSMITTERS, RECEIVERS, AND NETWORK INTERFACE DEVICES; SATELLITE NAVIGATIONAL SYSTEMS, NAMELY, A GLOBAL POSITIONING SYSTEM (GPS) (U.S. CLS. 21, 23, 26, 36 AND 38).

CLASS 14—JEWELRY

FOR PRECIOUS METALS AND THEIR ALLOYS AND GOODS IN PRECIOUS METALS OR COATED THEREWITH, NOT INCLUDED IN OTHER CLASSES, NAMELY, JEWELLERY, WATCHES; JEWELLERY; PRECIOUS STONES; HOROLOGICAL AND CHRONOMETRIC INSTRUMENTS, NAMELY, CHRONOMETERS FOR USE AS WATCHES, TRAVEL CLOCKS; TRAVEL CLOCKS; WATCHES (U.S. CLS. 2, 27, 28 AND 50).

CLASS 18—LEATHER GOODS

FOR LEATHER AND IMITATIONS OF LEATHER; GOODS MADE OF LEATHER AND IMITATIONS OF LEATHER NOT INCLUDED IN OTHER CLASSES, NAMELY, LUGGAGE, BRIEFCASES; ANIMAL SKINS AND HIDES; TRUNKS AND TRAVELLING BAGS; UMBRELLAS, PARASOLS AND WALKING STICKS; WHIPS, HARNESSES AND SADDLERY; ALL PURPOSE SPORTING BAGS; BACKPACKS; RUCKSACKS; DUFFEL BAGS; SHOULDER BAGS; TRAVEL BAGS; SUITCASES; CAMPING BAGS, NAMELY, BACKPACKS, POUCHES AND BAGS SOLD EMPTY FOR ATTACHMENT TO BACKPACKS, PROTECTIVE FITTED LINERS FOR BACKPACKS; WASHING BAGS, NAMELY, SHAVING BAGS SOLD EMPTY; TOILETRY BAGS SOLD EMPTY; WAIST BAGS; WAIST PACKS; FANNY PACKS; WAIST POUCHES, NAMELY, POUCHES FOR HOLDING MAKE-UP, KEYS, AND OTHER PERSONAL ITEMS; HYDRATION PACKS, NAMELY, WAIST PACK HYDRATION SYSTEMS CONSISTING OF A WAIST PACK, A RESERVOIR, AND A MOUTHPIECE CONNECTED TO THE RESERVOIR BY TUBE; HIKING BAGS; HIKING RUCKSACKS; HARNESSES, NAMELY, SHOULDER HARNESSES; MOUNTAINEERING STICKS; HIKING POLES; HIKING STICKS; PURSES AND WALLETS; DOCUMENT CASES (U.S. CLS. 1, 2, 3, 22 AND 41).

CLASS 22—CORDAGE AND FIBERS

FOR ROPES; STRING; NETS, NAMELY, FISHING NETS, BUTTERFLY NETS, INSECT PROTECTION NETS; TENTS; AWNINGS; TARPAULINS; SAILS, SACKS AND BAGS, NAMELY, SACKS OR BAGS FOR THE TRANSPORTATION OR STORAGE OF MATERIALS IN BULK; PADDING AND STUFFING MATERIALS NOT OF RUBBER, PAPER, OR PLASTIC; RAW FIBROUS TEXTILE MATERIALS; TENTS FOR MOUNTAINEERING OR CAMPING; MOUNTAINEERING ROPES; ROPES FOR TENTS; AWNINGS FOR TENTS, NAMELY, AWNINGS NOT OF METAL; TENT STORAGE BAGS, NAMELY, POLY PROPYLENE BAGS USED FOR THE STORAGE OF TENTS, MESH BAGS FOR STORAGE OF TENTS; CLOTH BAGS FOR STORAGE, NAMELY, BAGS MADE OF TEXTILE FOR THE STORAGE OF TENTS; CLOTHESLINE OF ROPE AND CORD; HAMMOCKS; GROUND SHEETS, NAMELY, VINYL GROUND CLOTH (U.S. CLS. 1, 2, 7, 19, 22, 42 AND 50).

CLASS 25—CLOTHING

FOR CLOTHING, NAMELY, FOOTWEAR, JACKETS, COATS, FLEECE VESTS, FLEECE PULLOVERS, FLEECE SHORTS, PULLOVERS, TROUSERS, SHIRTS, VESTS, T-SHIRTS, SWEATSHIRTS, SHORTS, SOCKS, GLOVES, HAND-WARMERS, GAITERS, BANDANAS, EARMUFFS, VISORS, SCARVES; HEADGEAR, NAMELY, CAPS, HATS, BEANIES, BALACLAVAS; BELTS FOR WEAR; BEACHWEAR; SWIMWEAR; UNDERWEAR; THERMAL UNDERWEAR; BOOTS; SHOES; SANDALS; AQUA SHOES; ARTICLES OF CLOTHING FOR HIKING, NAMELY, HIKING SHOES, HIKING BOOTS; ARTICLES OF CLOTHING FOR SKIING OR SNOWBOARDING, NAMELY, SKI GAITERS, SKI HATS, SKI JACKETS, SKI PANTS, SKI SUITS, SKI TROUSERS; MOUNTAINEERING BOOTS; HIKING BOOTS; SKI BOOTS; WIND RESISTANT TOPS; WIND RESISTANT JACKETS (U.S. CLS. 22 AND 39).

CLASS 35—ADVERTISING AND BUSINESS

FOR ADVERTISING SERVICES; BUSINESS MANAGEMENT; BUSINESS ADMINISTRATION SERVICES, NAMELY, ADMINISTRATION OF BUSINESS PAYROLL FOR OTHERS AND ADMINISTRATION OF THE BUSINESS AFFAIRS OF RETAIL STORES AND FRANCHISES; PROVIDING OFFICE FUNCTIONS; RETAIL STORE SERVICES IN THE FIELD OF MOUNTAINEERING, HIKING, RAMBLING, CAMPING, SPORTING AND OUTDOOR RECREATIONAL ACTIVITIES (U.S. CLS. 100, 101 AND 102).

KEVIN CORWIN, EXAMINING ATTORNEY

SN 79-072,908. CLASSICBERRY LIMITED, UNITED KINGDOM, FILED 6-16-2009.



PRIORITY DATE OF 12-22-2008 IS CLAIMED.
OWNER OF INTERNATIONAL REGISTRATION 1013291 DATED 6-16-2009, EXPIRES 6-16-2019.
THE MARK IDENTIFIES JIMMY PAGE, A LIVING INDIVIDUAL, WHOSE CONSENT IS OF RECORD.

CLASS 15—MUSICAL INSTRUMENTS

FOR MUSICAL INSTRUMENTS; MUSICAL INSTRUMENT ACCESSORIES, NAMELY, CARRYING BAGS FOR MUSICAL INSTRUMENTS (U.S. CLS. 2, 21 AND 36).

CLASS 25—CLOTHING

FOR CLOTHING, NAMELY, T-SHIRTS, JACKETS, PANTS, UNDERWEAR, SWEATERS, SHIRTS, TIES, SKIRTS, SOCKS, SCARVES, SHORTS, DRESSES, BELTS; FOOTWEAR; HEADGEAR, NAMELY, HEADWEAR (U.S. CLS. 22 AND 39).

MARK SPARACINO, EXAMINING ATTORNEY

SN 79-074,701. BAKKAVOR GROUP HF, IS-108 REYKJAVIK, ICELAND, FILED 7-8-2009.



PRIORITY DATE OF 1-8-2009 IS CLAIMED.
OWNER OF INTERNATIONAL REGISTRATION 1018171 DATED 7-8-2009, EXPIRES 7-8-2019.
THE MARK CONSISTS OF A PARTIAL IMAGE OF TINES AND HANDLE OF A FORK ON A DARK BACKGROUND.

CLASS 29—MEATS AND PROCESSED FOODS

FOR MEAT, FISH, POULTRY AND GAME; PREPARED MEAT, FISH, POULTRY AND GAME; MEAT EXTRACTS; PRESERVED, FROZEN, DRIED AND COOKED FRUITS AND VEGETABLES; JELLIES, JAMS, COMPOTES; EGGS, MILK AND MILK PRODUCTS EXCLUDING ICE CREAM, ICE MILK AND FROZEN YOGURT; DAIRY-BASED BEVERAGES; EDIBLE OILS AND FATS (U.S. CL. 46).

CLASS 30—STAPLE FOODS

FOR COFFEE, TEA, COCOA, SUGAR, RICE; FLOUR, BREAD, PASTRY, EDIBLE ICES; MUSTARD; VINEGAR, SAUCES; SPICES; SALAD DRESSINGS (U.S. CL. 46).

CLASS 31—NATURAL AGRICULTURAL PRODUCTS

FOR AGRICULTURAL GRAINS FOR PLANTING AND BULBS FOR HORTICULTURAL PURPOSES; FRESH FRUITS AND VEGETABLES; SEEDS AND BULBS, NATURAL PLANTS AND FLOWERS (U.S. CLS. 1 AND 46).

CLASS 35—ADVERTISING AND BUSINESS

FOR BUSINESS MANAGEMENT, PLANNING AND CONSULTING SERVICES FOR SUBSIDIARIES AND AFFILIATED COMPANIES; PROMOTING INVESTMENT IN COMPANIES THROUGH THE ANALYSIS AND DISSEMINATION OF INVESTMENT-RELATED INFORMATION (U.S. CLS. 100, 101 AND 102).

CLASS 36—INSURANCE AND FINANCIAL

FOR INVESTMENT SERVICES, NAMELY, ASSET ACQUISITION, CONSULTATION, DEVELOPMENT AND MANAGEMENT SERVICES; FUND RAISING SERVICES, NAMELY, SOLICITING POTENTIAL INVESTORS IN COMPANIES (U.S. CLS. 100, 101 AND 102).

CLASS 40—MATERIAL TREATMENT

FOR MANUFACTURE OF FRESH AND FROZEN PREPARED FOOD PRODUCTS TO ORDER OR SPECIFICATION OF OTHERS (U.S. CLS. 100, 103 AND 106).
JESSICA FATHY, EXAMINING ATTORNEY

SN 79-075,626. TELESPAZIO S.P.A., ITALY, FILED 9-11-2009.



PRIORITY DATE OF 5-25-2009 IS CLAIMED.
OWNER OF INTERNATIONAL REGISTRATION 1020217 DATED 9-11-2009, EXPIRES 9-11-2019.
NO CLAIM IS MADE TO THE EXCLUSIVE RIGHT TO USE "COMPANY", APART FROM THE MARK AS SHOWN. THE COLOR(S) RED AND GREY IS/ARE CLAIMED AS A FEATURE OF THE MARK.

THE TRADEMARK CONSISTS OF THE WORD "E-GEOS" IN GREY LOWER CASE LETTERS, EXCEPT THE "DASH" AND THE LETTER "O" WHICH ARE RED. IN THE TOP LEFT HAND OF THE LETTER "O" OF "E-GEOS" THERE IS A RED TRIANGLE WHOSE VERTEX TOWARDS THE SAME LETTER OF LETTER "O". UNDER THE WORD "E-GEOS" THERE IS THE EXPRESSION "AN ASI/TELESPAZIO COMPANY" IN RED CAPITAL LETTERS AND OF LOWER SIZE COMPARED TO "E-GEOS".

CLASS 9—ELECTRICAL AND SCIENTIFIC APPARATUS

FOR RADAR AND ELECTRONIC APPARATUS IN THE NATURE OF SATELLITES, ANTENNAS, TRANSMITTERS, RECEIVERS, COMPUTER AND SOFTWARE FOR OPERATING THE AFORESAID ELECTRONIC APPARATUS FOR AIR AND SATELLITE SURVEILLANCE AND FOR ACQUISITION AND PROCESSING OF DATA AND IMAGES AND SURVEILLANCE OF THE EARTH'S SURFACE, SEA, OBJECTS AND PEOPLE FOR CIVIL AND MILITARY USE; HARDWARE AND SOFTWARE, FOR ELECTRONIC APPARATUS FOR AIR AND SATELLITE SURVEILLANCE AND FOR ACQUISITION AND PROCESSING OF DATA AND IMAGES AND SURVEILLANCE OF THE EARTH'S SURFACE, SEA, OBJECTS AND PEOPLE FOR CIVIL AND MILITARY USE, NAMELY, COMPUTER HARDWARE AND COMPUTER SOFTWARE FOR PROCESSING AND EDITING DIGITAL DATA AND IMAGES; ELECTRONIC PUBLICATIONS, NAMELY, WEB PAGES, BOOK, MAGAZINE, MANUAL, FEATURING EARTH'S SURFACE, SEA, OBJECTS, ROUTE AND PEOPLE RECORDED ON COMPUTER MEDIA AND WEB SITES DOWNLOADABLE VIA THE "INTERNET", AND IN COMPUTER MEDIA; READABLE AND DOWNLOADABLE ELECTRONIC GEOGRAPHIC MAPS; READABLE AND DOWNLOADABLE DIGITAL IMAGES OF THE EARTH'S SURFACE, SEA, OBJECTS AND PEOPLE TAKEN FROM THE ATMOSPHERE, FROM SPACE OR FROM THE GROUND FOR CIVIL AND MILITARY USE; ELECTRONIC APPARATUS IN THE NATURE OF SATELLITES, ANTENNAS, TRANSMITTERS, RECEIVERS, COMPUTER AND SOFTWARE FOR OPERATING THE AFORESAID ELECTRONIC APPARATUS FOR THE IDENTIFICATION AND SURVEILLANCE FROM THE ATMOSPHERE, FROM SPACE AND FROM GROUND, OF SHIPS AND BOATS, OF MARITIME TRAFFIC, OF OFFSHORE PLATFORMS, OF OIL LEAKS, OF ICEBERGS AND ICE BANKS OR OTHER OBJECTS IN THE SEA; ELECTRONIC APPARATUS IN THE NATURE OF SATELLITES, ANTENNAS, TRANSMITTERS, RECEIVERS, COMPUTER AND SOFTWARE FOR OPERATING THE AFORESAID ELECTRONIC APPARATUS FOR THE PREVENTION, IDENTIFICATION AND SURVEILLANCE FROM THE ATMOSPHERE, FROM SPACE AND FROM THE GROUND OF FALLS, LANDSLIDES, SUBSIDENCES, FIRES, FLOODS, EARTHQUAKES, VOLCANIC ERUPTIONS, OF ICE AND SNOW AND OF OTHER CLIMATIC OR ENVIRONMENTAL EVENTS; ELECTRONIC APPARATUS SATELLITES, ANTENNAS, TRANSMITTERS, RECEIVERS, COMPUTER AND SOFTWARE FOR OPERATING THE AFORESAID ELECTRONIC APPARATUS FOR THE CHECKING AND SURVEILLANCE OF TERRITORY FROM THE ATMOSPHERE OR FROM SPACE FOR THE MANAGING OF PEOPLE RESCUE, FOR THE PROTECTION OF PEOPLE AND TERRITORIES FROM UNLAWFUL ACTIVITIES AND FROM THREATS TO SECURITY; ELECTRONIC APPARATUS IN THE NATURE OF SATELLITES, ANTENNAS, TRANSMITTERS, RECEIVERS, COMPUTER AND SOFTWARE FOR OPERATING THE AFORESAID ELECTRONIC APPARATUS FOR MAPPING THE EARTH SURFACE AND FOR GEOLOGIC EXPLORATION FROM THE ATMOSPHERE, FROM SPACE AND FROM THE GROUND; ELECTRONIC APPARATUS, NAMELY, COMPUTER HARDWARE AND COMPUTER DATABASE MANAGEMENT SOFTWARE FOR MANAGING GEOGRAPHIC AND TERRITORIAL INFORMATION FOR USE IN MAPPING (U.S. CLS. 21, 23, 26, 36 AND 38).

CLASS 12—VEHICLES

FOR SPACE VEHICLES, SATELLITES, AIRCRAFT, LAND VEHICLES AND OTHER APPARATUS IN THE NATURE OF SHIPS FOR LAND OR SEA LOCOMOTION FOR ACQUISITION AND PROCESSING OF DATA AND IMAGES AND/OR THE SURVEILLANCE OF THE EARTH'S SURFACE, OF THE SEA, OBJECTS OR PEOPLE FOR CIVIL AND MILITARY USE (U.S. CLS. 19, 21, 23, 31, 35 AND 44).

CLASS 16—PAPER GOODS AND PRINTED MATTER

FOR PHOTOGRAPHS AND PRINTED MATTER IN THE NATURE OF PHOTOGRAPHIC PRINTS AND PRINTED MAPS RELATING TO IMAGES OF EARTH'S SURFACE, OF THE SEA, OBJECTS AND PEOPLE TAKEN FROM THE ATMOSPHERE OR FROM SPACE FOR CIVIL AND MILITARY USE; GEOGRAPHIC MAPS AND PLANS (U.S. CLS. 2, 5, 22, 23, 29, 37, 38 AND 50).

CLASS 38—COMMUNICATION

FOR TELECOMMUNICATIONS SERVICES, NAMELY, SATELLITE TELECOMMUNICATIONS, COMMUNICATION BETWEEN RECEIVERS AND TRANSMITTERS BASED IN SATELLITES AND TRANSMITTERS AND RECEIVERS BASED IN LAND VEHICLES, SHIPS, AIRCRAFTS AND ON GROUND; COMMUNICATIONS THROUGH COMPUTER NETWORKS, COMMUNICATIONS THROUGH THE COMPUTER NETWORK DENOMINATED "INTERNET", TRANSFER OF DATA BY TELECOMMUNICATIONS (U.S. CLS. 100, 101 AND 104).

CLASS 41—EDUCATION AND ENTERTAINMENT

FOR EDUCATIONAL SERVICES, NAMELY, PROVIDING CLASSES, SEMINARS, CONFERENCES, WORKSHOPS, AND TRAINING IN THE FIELDS OF AIR AND SATELLITE SURVEILLANCE, DATA AND IMAGES ACQUISITION AND PROCESSING AND SURVEILLANCE OF THE EARTH'S SURFACE, OF THE SEA, OBJECTS AND PEOPLE FOR CIVIL AND MILITARY USE (U.S. CLS. 100, 101 AND 107).

CLASS 42—SCIENTIFIC AND COMPUTER SERVICES

FOR AIR AND SATELLITE SURVEILLANCE, PROVIDING TEMPORARY USE OF NON-DOWNLOADABLE COMPUTER SOFTWARE FOR USE IN DATA AND IMAGES ACQUISITION AND PROCESSING AND/OR SURVEILLANCE OF THE EARTH'S SURFACE, OF THE SEA, OBJECTS AND PEOPLE; DESIGN AND DEVELOPMENT OF COMPUTER HARDWARE AND COMPUTER SOFTWARE RELATING TO THE ACQUISITION AND PROCESSING OF DATA AND IMAGES AND SURVEILLANCE OF THE EARTH'S SURFACE, OF THE SEA, OBJECTS AND PEOPLE FOR CIVIL AND MILITARY; PROVIDING TEMPORARY USE OF NON-DOWNLOADABLE COMPUTER SOFTWARE FOR USE IN ACQUISITION AND PROCESSING OF DATA AND IMAGES OF THE EARTH'S SURFACE, OF THE SEA, OBJECTS AND PEOPLE; PROVIDING TEMPORARY USE OF NON-DOWNLOADABLE COMPUTER SOFTWARE FOR USE IN ACQUISITION AND PROCESSING OF DATA AND IMAGES OF BUILDINGS AND OTHER REAL ESTATE FROM THE ATMOSPHERE, FROM SPACE AND FROM THE GROUND FOR USE IN PROVIDING REPORTS, SURVEYS, MAPS, SCHEMES, DRAWINGS, DESIGNS, MAPS, DATA AND IMAGES FOR URBAN PLANNING, FOR THE MANAGING OF TERRITORY OR LAND REGISTRY; MAPPING SERVICES OF THE EARTH'S SURFACE; GEOLOGIC EXPLORATION IN THE NATURE OF SURVEYS AND ESTIMATIONS FROM THE ATMOSPHERE AND FROM SPACE AND FROM THE GROUND (U.S. CLS. 100 AND 101).

CLASS 45—PERSONAL AND LEGAL SERVICES

SN 79-077,216. BUONGIORNO S.P.A., ITALY, FILED 11-4-2009.

FOR CIVIL AND MILITARY SERVICES RELATING TO AIR AND SATELLITE SURVEILLANCE FEATURING THE ACQUISITION AND PROCESSING OF DATA AND IMAGES FOR MONITORING AND DEFENDING THE TERRITORY AND THE ENVIRONMENT; AIR AND SATELLITE SURVEILLANCE FEATURING THE ACQUISITION AND PROCESSING OF DATA AND IMAGES FOR THE DETECTION AND MONITORING OF FALLS, LANDSLIDES, SUBSIDENCES, FIRES, FLOODS, EARTHQUAKES, VULCANIC ERUPTIONS, ICEBERGS OR ICE BANKS, OIL LEAKS IN THE SEA AND OTHER EMERGENCIES; AIR AND SATELLITE SURVEILLANCE FEATURING THE ACQUISITION AND PROCESSING OF DATA AND IMAGES FOR MONITORING OF TERRITORIAL BOUNDARIES, FOR MANAGING PEOPLE RESCUE, FOR PROTECTION OF PEOPLE AND TERRITORIES FROM UNLAWFUL ACTIVITIES AND FROM THREATS TO SECURITY (U.S. CLS. 100 AND 101).

ERNEST SHOSHO, EXAMINING ATTORNEY

BLINKO

SN 79-077,208. DE WILD BV, NETHERLANDS, FILED 11-24-2009.



The logo consists of the letters "GTM" in a large, bold, outlined font, with the word "PROFESSIONAL" in a smaller, solid, bold font directly below it.

OWNER OF INTERNATIONAL REGISTRATION 1024573 DATED 11-24-2009, EXPIRES 11-24-2019.

NO CLAIM IS MADE TO THE EXCLUSIVE RIGHT TO USE "PROFESSIONAL", APART FROM THE MARK AS SHOWN.

THE COLOR(S) BLACK AND SILVER IS/ARE CLAIMED AS A FEATURE OF THE MARK.

THE MARK CONSISTS OF TWO SILVER STRIPES OVER WHICH ARE THE LETTERS "GTM" OUTLINED IN BLACK; THE WORDING "PROFESSIONAL" BELOW IN BLACK; WHITE IS NOT CLAIMED AS A FEATURE OF THE MARK.

THE WORDING "GTM" HAS NO MEANING IN A FOREIGN LANGUAGE.

SEC. 2(F).

CLASS 7—MACHINERY

FOR MACHINES, NAMELY, LAWN MOWERS, RIDE-ON LAWN MOWERS, BRUSH CUTTERS, WATER PUMPS FOR AGRICULTURAL AND GARDENING USE, POWER OPERATED PLATE COMPACTORS, POWER-OPERATED WOOD CHIPPER AND SHREDDERS FOR AGRICULTURAL, GARDENING AND FORESTRY USE, POWER OPERATED LEAF BLOWERS, POWER OPERATED CHAINSAWS, POWER OPERATED HEDGE TRIMMERS, POWER OPERATED CHAIN GRINDERS FOR CHAIN SAWS, POWER OPERATED LAWN EDGERS, POWER OPERATED EARTH AUGERS, POWER OPERATED STUMP GRINDERS, POWER OPERATED TILLERS FOR AGRICULTURAL AND GARDENING USE, AND SPARE MACHINE PARTS THEREFOR (U.S. CLS. 13, 19, 21, 23, 31, 34 AND 35).

CLASS 8—HAND TOOLS

FOR HAND TOOLS, NAMELY, HANDSAWS IN THE NATURE OF POLE SAWS, FOLDING SAWS AND FIXED SAWS, PRUNING SHEARS, FLOWER SHEARS, PICKING SHEARS AND FRUIT PRUNERS, HARVEST SHEARS, LAWN EDGERS, HEDGE SHEARS, LOPPERS AND PRUNING SHEARS ON POLE (U.S. CLS. 23, 28 AND 44).

SUE LAWRENCE, EXAMINING ATTORNEY

THE MARK CONSISTS OF STANDARD CHARACTERS WITHOUT CLAIM TO ANY PARTICULAR FONT, STYLE, SIZE, OR COLOR.

OWNER OF INTERNATIONAL REGISTRATION 1024594 DATED 11-4-2009, EXPIRES 11-4-2019.

OWNER OF U.S. REG. NO. 3,187,585.

CLASS 9—ELECTRICAL AND SCIENTIFIC APPARATUS

FOR SCIENTIFIC, NAUTICAL, SURVEYING, PHOTOGRAPHIC, CINEMATOGRAPHIC, OPTICAL, WEIGHING, MEASURING, SIGNALLING, CHECKING, SUPERVISION, LIFE-SAVING AND TEACHING APPARATUS AND INSTRUMENTS, NAMELY, CAMERAS; APPARATUS AND INSTRUMENTS FOR CONDUCTING, SWITCHING, TRANSFORMING, ACCUMULATING, REGULATING OR CONTROLLING ELECTRICITY, NAMELY, TRANSFORMERS AND ELECTRICAL SWITCHES; APPARATUS FOR RECORDING, TRANSMISSION OR REPRODUCTION OF SOUND OR IMAGES, NAMELY, DIGITAL VIDEO RECORDERS; PRE-RECORDED AUDIO AND VIDEO TAPES AND CASSETTES FEATURING MUSIC; PRERECORDED COMPACT DISCS, CD-ROMS AND DVDS FEATURING GAMES AND MUSIC; MOBILE PHONES; BLANK MAGNETIC DATA CARRIERS; BLANK RECORD DISCS; PRE-RECORDED MAGNETIC DATA CARRIERS FEATURING MUSIC, DRAMA AND COMEDY; DOWNLOADABLE COMPUTER SOFTWARE FOR USE IN ENABLING INTERACTIVE PLAY OF SIMULATED COMPUTER GAMES AND COMPUTER SIMULATED SPORTING EVENTS, AND FOR USE IN DELIVERY OF WIRELESS AND VIDEO MULTIMEDIA CONTENT, DOWNLOADABLE RINGTONES, MUSIC, DOWNLOADABLE MP3 FILES, COMPUTER GRAPHICS, COMPUTER GAMES AND VIDEO IMAGES FOR WIRELESS MOBILE COMMUNICATION DEVICES; DOWNLOADABLE COMPUTER SCREEN SAVER SOFTWARE FOR MOBILE COMMUNICATION DEVICES; DOWNLOADABLE MUSIC AND ELECTRONIC GAMES VIA THE INTERNET AND WIRELESS DEVICES; DOWNLOADABLE VIDEO RECORDING FEATURING MUSIC; INTERACTIVE GAME PROGRAMS FOR COMPUTERS AND HOME ENTERTAINMENT SYSTEMS (U.S. CLS. 21, 23, 26, 36 AND 38).

CLASS 38—COMMUNICATION

FOR TELECOMMUNICATION SERVICES, NAMELY, ELECTRONIC, DIGITAL, WIRED AND WIRELESS TRANSMISSION OF SOUND RECORDINGS, VIDEOS, TEXT, PICTURES, DRAWINGS, VOICE, DATA, INFORMATION, SIGNALS AND MESSAGES BY MEANS OF TELEPHONE, TELEVISION AND GLOBAL COMMUNICATION NETWORKS; TELECOMMUNICATION ACCESS SERVICES; TELECOMMUNICATION SERVICES, NAMELY, PERSONAL COMMUNICATION SERVICES; MOBILE MEDIA SERVICES IN THE NATURE OF ELECTRONIC TRANSMISSION OF ENTERTAINMENT MEDIA CONTENT; ELECTRONIC EXCHANGE OF DATA STORED IN DATABASES ACCESSIBLE VIA TELECOMMUNICATION NETWORKS; PROVIDING ACCESS TO TELECOMMUNICATION NETWORKS; SIGNAL TRANSMISSION FOR ELECTRONIC COMMERCE VIA TELECOMMUNICATION SYSTEMS AND DATA COMMUNICATION SYSTEMS; LOCAL AND LONG DISTANCE TELEPHONE SERVICES BY MEANS OF ELECTRONIC, DIGITAL, CELLULAR, WIRED AND WIRELESS TELECOMMUNICATION; LOCAL AND LONG DISTANCE TRANSMISSION OF VOICE, DATA, GRAPHICS BY MEANS OF TELEPHONE AND SATELLITE TRANSMISSIONS; TELECOMMUNICATIONS GATEWAY SERVICES; TRANSFER OF DATA BY TELECOMMUNICATIONS; TRANSMISSION OF DATABASE INFORMATION VIA TELECOMMUNICATIONS NETWORKS (U.S. CLS. 100, 101 AND 104).

CLASS 41—EDUCATION AND ENTERTAINMENT

FOR EDUCATIONAL SERVICES, NAMELY, PROVIDING CLASSES, SEMINARS, CONFERENCES AND WORKSHOPS IN THE FIELD OF TELECOMMUNICATIONS, MARKETING, MUSIC ENTERTAINMENT, COMPUTER GAME ENTERTAINMENT, INTERNET TECHNOLOGY AND CREATION OF MULTIMEDIA ENTERTAINMENT CONTENT FOR WIRELESS DEVICES; PROVIDING TRAINING IN THE FIELD OF TELECOMMUNICATIONS, MARKETING, MUSIC ENTERTAINMENT AND CREATION OF MULTIMEDIA ENTERTAINMENT CONTENT FOR WIRELESS DEVICES; ENTERTAINMENT SERVICES, NAMELY, NON-DOWNLOADABLE RINGTONES, PRE-RECORDED MUSIC, AND GRAPHICS PRESENTED TO MOBILE COMMUNICATIONS DEVICES VIA A GLOBAL COMPUTER NETWORK AND WIRELESS NETWORKS; ENTERTAINMENT SERVICES, NAMELY, PROVIDING A WEBSITE FEATURING PHOTOGRAPHIC, AUDIO AND VIDEO PRESENTATIONS FEATURING MUSIC, PERFORMANCES BY MUSICIANS AND FASHION MODELS, AND SPORTS ENTERTAINMENT; ORGANIZING COMMUNITY SPORTING AND CULTURAL EVENTS (U.S. CLS. 100, 101 AND 107).

EVELYN BRADLEY, EXAMINING ATTORNEY

SN 79-079,329. TURCAN CONNELL (TRUSTEES) LIMITED, UNITED KINGDOM, FILED 12-14-2009.

THE VOLANT CHARITABLE TRUST

THE MARK CONSISTS OF STANDARD CHARACTERS WITHOUT CLAIM TO ANY PARTICULAR FONT, STYLE, SIZE, OR COLOR.

PRIORITY DATE OF 7-2-2009 IS CLAIMED.

OWNER OF INTERNATIONAL REGISTRATION 1029898 DATED 12-14-2009, EXPIRES 12-14-2019.

NO CLAIM IS MADE TO THE EXCLUSIVE RIGHT TO USE "CHARITABLE TRUST", APART FROM THE MARK AS SHOWN.

CLASS 16—PAPER GOODS AND PRINTED MATTER

FOR PERIODICAL PUBLICATIONS, NAMELY, NEWSPAPERS, MAGAZINES, AND NEWSLETTERS IN THE FIELDS OF MULTIPLE SCLEROSIS AND SOCIAL DEPRIVATION; LEAFLETS, PAMPHLETS, CIRCULARS, ADVERTISING MATERIAL, NAMELY, ADVERTISING PAMPHLETS, ADVERTISING SIGNS OF PAPER OR CARDBOARD, PRINTED BROCHURES REGARDING MULTIPLE SCLEROSIS AND SOCIAL DEPRIVATION, STATIONERY AND PRINTED INSTRUCTIONAL AND TEACHING MATERIALS ALL IN THE FIELDS OF MULTIPLE SCLEROSIS AND SOCIAL DEPRIVATION (U.S. CLS. 2, 5, 22, 23, 29, 37, 38 AND 50).

CLASS 36—INSURANCE AND FINANCIAL

FOR CHARITABLE FUNDRAISING; PROVISION OF GRANTS TO EDUCATIONAL INSTITUTIONS, RESEARCH ORGANIZATIONS AND CHARITIES WORKING IN THE FIELDS MULTIPLE SCLEROSIS AND SOCIAL DEPRIVATION; FINANCING OF PROJECTS FOR OTHERS; MANAGEMENT OF CHARITABLE FUNDS; ADVISORY, CONSULTANCY AND INFORMATION SERVICES IN RELATION TO ALL OF THE AFORESAID SERVICES IN THE FIELDS OF CHARITABLE FUNDRAISING, THE PROVISION OF GRANTS, MANAGING CHARITABLE FUNDS AND FINANCING PROJECTS FOR OTHERS (U.S. CLS. 100, 101 AND 102).

CLASS 42—SCIENTIFIC AND COMPUTER SERVICES

FOR SCIENTIFIC AND MEDICAL RESEARCH SERVICES IN THE FIELDS OF MULTIPLE SCLEROSIS AND SOCIAL DEPRIVATION AS IT RELATES TO NEUROCOGNITIVE DEFICITS IN THE BRAIN AND MENTAL ILLNESS; MEDICAL RESEARCH INTO THE CAUSES AND TREATMENT OF MULTIPLE SCLEROSIS; ADVISORY, CONSULTANCY AND INFORMATION SERVICES IN THE FIELD OF SCIENTIFIC AND MEDICAL RESEARCH RELATING TO MULTIPLE SCLEROSIS AND SOCIAL DEPRIVATION (U.S. CLS. 100 AND 101).

MYRIAH HABEEB, EXAMINING ATTORNEY

SN 79-081,137. EUROCOATING S.P.A., PERGINE VALSUGANA (TN), ITALY, FILED 12-23-2009.

TIPORE

THE MARK CONSISTS OF STANDARD CHARACTERS WITHOUT CLAIM TO ANY PARTICULAR FONT, STYLE, SIZE, OR COLOR.

PRIORITY DATE OF 11-9-2009 IS CLAIMED.

OWNER OF INTERNATIONAL REGISTRATION 1034855 DATED 12-23-2009, EXPIRES 12-23-2019.

THE WORDING "TIPORE" HAS NO MEANING IN A FOREIGN LANGUAGE.

CLASS 5—PHARMACEUTICALS

FOR TITANIUM OSTEOINTEGRATIVE COATINGS FOR MEDICAL PURPOSES, WHICH ENHANCE THE BONE TISSUE GROWTH ONTO IMPLANTABLE MEDICAL DEVICES AND PROSTHESES SURFACES (U.S. CLS. 6, 18, 44, 46, 51 AND 52).

CLASS 10—MEDICAL APPARATUS

FOR DENTAL IMPLANTS, ORTHOPEDIC PROSTHESES, NAMELY, DENTAL PROSTHESES, SHOULDER PROSTHESES, ELBOW PROSTHESES, HAND PROSTHESES, HIP PROSTHESES, KNEE PROSTHESES, JOINT PROSTHESES; PROSTHESES FOR VERTEBRAL COLUMNS, PROSTHESES FOR MAXILLOFACIAL RECONSTRUCTIONS OR NEUROSURGERY (U.S. CLS. 26, 39 AND 44).

CLASS 40—MATERIAL TREATMENT

FOR APPLYING TITANIUM COATINGS BY THERMAL SPRAY TO DENTAL IMPLANTS, ORTHOPEDIC PROSTHESES, PROSTHESES FOR VERTEBRAL COLUMNS, PROSTHESES FOR MAXILLOFACIAL RECONSTRUCTIONS OR NEUROSURGERY; PHYSICAL TREATMENT OF THE SURFACE OF MEDICAL DEVICE AND PROSTHESES BY PLASMA SPRAY, SINTERING, ACID ATTACK, SANDBLASTING, LASER DEPOSITION (U.S. CLS. 100, 103 AND 106).

MYRIAH HABEEB, EXAMINING ATTORNEY

SN 79-081,176. DECKEL MAHO PFRONTEN GMBH, FED REP GERMANY, FILED 3-22-2010.

DMG gearMILL

THE MARK CONSISTS OF STANDARD CHARACTERS WITHOUT CLAIM TO ANY PARTICULAR FONT, STYLE, SIZE, OR COLOR.

PRIORITY DATE OF 9-22-2009 IS CLAIMED.

OWNER OF INTERNATIONAL REGISTRATION 1034967 DATED 3-22-2010, EXPIRES 3-22-2020.

NO CLAIM IS MADE TO THE EXCLUSIVE RIGHT TO USE "GEAR MILL", APART FROM THE MARK AS SHOWN.

THE WORDING "DMG" HAS NO MEANING IN A FOREIGN LANGUAGE.

CLASS 7—MACHINERY

FOR MACHINE TOOL HOUSINGS, NAMELY, BEARING HOUSINGS BEING PARTS OF MACHINES, MACHINE TOOLS, NAMELY, MILLING CUTTERS, LATHES AND PARTS AND ACCESSORIES THEREFOR, NAMELY, MECHANICAL CLAMPING APPARATUS, NAMELY, CLAMPS FOR USE IN THE PRECISION CLAMPING OF WORK PIECES, MECHANICAL TOOLS, NAMELY, MECHANICAL SPREADERS, AND TOOL CHANGERS FOR MACHINE TOOLS, NAMELY, MACHINE PARTS FOR AUTOMATICALLY CHANGING THE BLADES ON CUTTING TOOLS, TOOL STORES FOR MACHINE TOOLS, NAMELY, MACHINE TOOL HOLDERS, MECHANICAL HANDLING APPARATUS, NAMELY, PALLETIZERS, CASE ELEVATORS, AUTOMATIC PALLET DISPENSING MACHINES AND AUTOMATIC SLIP SHEET DISPENSING MACHINES, WORK PIECE PALLETS, NAMELY, PALLETIZERS AS PARTS OF MACHINES, VICES FOR USE IN THE PRECISION CLAMPING OF WORK PIECES BEING MACHINE PARTS, MACHINE TOOLS IN THE NATURE OF MANUALLY AND NUMERICALLY CONTROLLED DIVIDING MECHANISMS, NAMELY, METAL DIVIDING MACHINES CONSISTING OF UNIT INSTALLATIONS, NAMELY, CIRCULAR DIVIDING APPARATUS, DIVIDING PLATES, DIVIDING ATTACHMENTS AND CIRCULAR TABLES; WORK BENCHES BEING PARTS OF MACHINE TOOLS; PARTS AND ACCESSORIES FOR MACHINE TOOLS, NAMELY, HYDRAULIC AND PNEUMATIC CONTROLS FOR MACHINES; MANUFACTURING SYSTEMS IN THE NATURE OF MACHINE TOOLS AND NUMERICALLY-CONTROLLED MACHINE TOOLS, NAMELY, LATHES, GEAR CUTTERS, CHASERS AND BROACHES, INDUSTRIAL ROBOTS WITH CONTROL DEVICES, AUTOMATIC HANDLING MACHINES, NAMELY, PALLETIZERS, CASE ELEVATORS, AUTOMATIC PALLET DISPENSING MACHINES AND AUTOMATIC SLIP SHEET DISPENSING MACHINES,

MECHANICAL CONVEYING APPARATUS, NAMELY, CONVEYORS BEING PARTS OF MACHINES (U.S. CLS. 13, 19, 21, 23, 31, 34 AND 35).

CLASS 9—ELECTRICAL AND SCIENTIFIC APPARATUS

FOR MEASURING AND TESTING MACHINES AND INSTRUMENTS, NAMELY, EQUIPMENT FOR USE IN MEASURING THE TEMPERATURE, PRESSURE, POSITION OR FORM OF WORK PIECES IN A MACHINE TOOL, AND FOR USE IN TESTING THE PERFORMANCE AND EFFICIENCY OF POWER PLANT EQUIPMENT (U.S. CLS. 21, 23, 26, 36 AND 38).

MYRIAH HABEEB, EXAMINING ATTORNEY

SN 79-081,249. WIDEX A/S, DENMARK, FILED 3-19-2010.

DEX

THE MARK CONSISTS OF STANDARD CHARACTERS WITHOUT CLAIM TO ANY PARTICULAR FONT, STYLE, SIZE, OR COLOR.

PRIORITY DATE OF 10-15-2009 IS CLAIMED.

OWNER OF INTERNATIONAL REGISTRATION 1035179 DATED 3-19-2010, EXPIRES 3-19-2020.

CLASS 9—ELECTRICAL AND SCIENTIFIC APPARATUS

FOR WIRELESS TRANSMITTER AND RECEIVER EQUIPMENT FOR USE IN CONNECTION WITH ELECTRO-ACOUSTIC APPARATUS FOR THE HARD OF HEARING, NAMELY, REMOTE CONTROLS FOR TRANSMISSION OF SOUND TO A HEARING AID FROM TELEVISIONS, MOBILE PHONES, TELECOILS AND FM SYSTEMS (U.S. CLS. 21, 23, 26, 36 AND 38).

CLASS 10—MEDICAL APPARATUS

FOR ASSISTIVE LISTENING DEVICES FOR THE HARD OF HEARING (U.S. CLS. 26, 39 AND 44).

KRISTIN CARLSON, EXAMINING ATTORNEY

SN 79-081,494. SIC LAZARO, S.L., E-31591 CORELLA (NAVARRA), SPAIN, FILED 10-15-2009.



OWNER OF INTERNATIONAL REGISTRATION 1035767 DATED 10-15-2009, EXPIRES 10-15-2019.

NO CLAIM IS MADE TO THE EXCLUSIVE RIGHT TO USE "INDUSTRIAL SYSTEMS OF COUNTERWEIGHTS", APART FROM THE MARK AS SHOWN.

THE NAME(S), PORTRAIT(S), AND/OR SIGNATURE(S) SHOWN IN THE MARK DOES NOT IDENTIFY A PARTICULAR LIVING INDIVIDUAL.

THE COLOR(S) DARK BLUE, LIGHT BLUE, WHITE, DARK GREY AND LIGHT GREY IS/ARE CLAIMED AS A FEATURE OF THE MARK.

THE MARK CONSISTS OF THE WORDING "SICLAZARO" ABOVE THE WORDING "INDUSTRIAL SYSTEMS OF COUNTERWEIGHTS", WITH THE LETTERS "SIC" IN DARK BLUE, THE LETTERS "LAZARO INDUSTRIAL SYSTEMS OF COUNTERWEIGHTS" IN DARK GREY, TO THE RIGHT OF A LIGHT GREY RECTANGLE IN WHICH A WHITE FIGURE HOLDS A LIGHT BLUE SPHERE WITH DARK BLUE AND WHITE SHADING.

CLASS 7—MACHINERY

FOR COMPONENT PARTS FOR ELEVATORS, NAMELY, COUNTERWEIGHTS; HOISTS; METAL PARTS AND FITTINGS FOR POWER-OPERATED LIFTING EQUIPMENT; COMPONENT PARTS OF MECHANICAL AND HYDRAULIC LIFTS, NAMELY, WEIGHTS, BALLAST AND COUNTERWEIGHTS; EARTHMOVING MACHINES, NAMELY, EXCAVATORS, FRONT LOADERS, BACKHOE LOADERS, WHEEL LOADERS, COMPACT TRUCK LOADERS, CRAWLER DOZERS, LANDSCAPE LOADERS, DRILLING MACHINES, MOTOR GRADERS, LIFTING PLATFORMS, SCISSORS LIFTS, FORKLIFTS, REACHSTACKERS, ROUGH TERRAIN CRANES, TRUCK CRANES, TELESCOPIC CRANES, CRAWLER CRANES, TOWER CRANES, MOBILE CRANES, LATTICE CRANES, PICK AND CARRY CRANES, OFFSHORE CRANES, FELLER BUNCHERS, SKIDDERS, KNUCKLEBOOM LOADERS, FORESTRY SWIM MACHINES, ENERGY WOOD HARVESTERS, HARVESTERS, FORWARDERS, GRAIN HARVESTING MACHINES, DRAGLINE EXCAVATORS, DRILLING MACHINES, SHOVELING MACHINES, EXCAVATORS, HIGHWALL MINERS, AND ROOM AND PILLAR MINING MACHINES; MACHINE TOOLS, NAMELY, CLAMPS AND ROTARY DIES FOR CUTTING; MOTORS AND ENGINES NOT FOR LAND VEHICLES; MACHINE COUPLING AND TRANSMISSION COMPONENTS NOT FOR LAND VEHICLES; MACHINE PARTS, NAMELY, ANTI-FRICTION BEARINGS AND BEARINGS; GENERATORS OF ELECTRICITY; ELECTRIC WELDING MACHINES; MACHINE WHEELS; HYDRAULIC AND PNEUMATIC CONTROLS FOR MACHINES, MOTORS AND ENGINES; CRANES; EXCAVATING MACHINES; LOADING BRIDGES, NAMELY, GANTRY CRANES; POWER OPERATED MECHANICAL SHOVELS; MACHINE PARTS, NAMELY, CHUCKS AND PULLEYS; ALTERNATORS; MACHINE PARTS, NAMELY, BLADES, ANTI-FRICTION PADS, REELS, CRANKS, SPRINGS AND VALVES; PISTONS FOR USE WITH CYLINDERS, MOTORS AND ENGINES; TRANSMISSION SHAFTS, BELTS AND MECHANISMS, OTHER THAN FOR LAND VEHICLES; TRANSMISSIONS FOR MACHINES; POWER OPERATED MECHANICAL HAND-HELD TOOLS, NAMELY, HAMMERS, DRILLS, STAPLE GUNS; PRESSURE REGULATORS SPECIALLY ADAPTED FOR USE WITH EARTHMOVING MACHINES; PNEUMATIC HAMMERS; AND COMPONENT PARTS FOR THE AFOREMENTIONED GOODS (U.S. CLS. 13, 19, 21, 23, 31, 34 AND 35).

CLASS 35—ADVERTISING AND BUSINESS

FOR BUSINESS CONSULTATION SERVICES CONCERNING THE OPERATION, MANAGEMENT AND ORGANIZATION OF COMPANIES; DEVELOPING PROMOTIONAL CAMPAIGNS FOR BUSINESS; BUSINESS MANAGEMENT ADVISORY SERVICES RELATING TO FRANCHISING; BUSINESS MANAGEMENT ADVISORY SERVICES CONCERNING COMMERCIAL FUNCTIONS OF INDUSTRIAL AND COMMERCIAL COMPANIES; ACCOUNTING; BUSINESS INFORMATION; PRODUCT DEMONSTRATION SERVICES; MARKETING STUDIES AND RESEARCH; ORGANIZATION OF EXHIBITIONS FOR COMMERCIAL OR ADVERTISING PURPOSES; PUBLIC RELATIONS; ADVERTISING; IMPORT-EXPORT AGENCY SERVICES; RETAIL STORE, WHOLESALE DISTRIBUTORSHIPS AND ONLINE RETAIL ORDERING SERVICES FEATURING ALL OF THE FOLLOWING: WEIGHTS AND BALLAST OF ANY MATERIAL FOR COUNTERWEIGHTED MACHINERY SYSTEMS AND VEHICLES, ACCESSORIES FOR LIFTS, MACHINERY AND VEHICLES, BUILDING MATERIALS, VEHICLE PARTS, COUNTERWEIGHTS, PARTS AND COMPONENTS FOR LIFTS AND HOISTS, CONCRETE AND METAL BLOCKS, AS WELL AS ALL KINDS OF ACCESSORIES, PARTS, COMPONENTS AND SPARE PARTS FOR LIFTS, VEHICLES AND

MACHINERY IN GENERAL, MESH AND LATTICE-WORK OF METAL, PERFORATED METAL FLOORS FOR STRUCTURES OF METAL, BUILDING MATERIALS OF METAL, METAL RAILINGS AND FENCES, COMMON METALS, UNWROUGHT OR SEMI-WROUGHT, AND THEIR ALLOYS, LAMINATED AND CAST BUILDING MATERIALS, IRONMONGERY AND CARPENTRY ARTICLES OF METAL, SMALL ITEMS OF METAL HARDWARE, TUBES OF METAL, BALLS OF STEEL, NAILS AND SCREWS, ORES, STEEL BUILDINGS, STEEL TUBES, VALVES FOR WATER PIPES, METAL SCAFFOLDING, WASHERS OF METAL, FRAMES FOR BUILDING, FRAMEWORKS OF METAL, TILES FOR BUILDING, GUTTERS OF METAL, FOUNDRY MOULDS OF METAL, POSTS OF METAL, RIVETS OF METAL, FLOORS AND PARTITIONS OF METAL, WIRE GAUZES AND GIRDERS OF METAL; ASSISTANCE IN FRANCHISED COMMERCIAL BUSINESS MANAGEMENT (U.S. CLS. 100, 101 AND 102).

TRACY FLETCHER, EXAMINING ATTORNEY

SN 79-081,866. SYNTEO HOLDING AB, SWEDEN, FILED 11-10-2009.



PRIORITY DATE OF 5-15-2009 IS CLAIMED.

OWNER OF INTERNATIONAL REGISTRATION 1036763 DATED 11-10-2009, EXPIRES 11-10-2019.

THE COLOR(S) BLUE 660, GREEN 584 IS/ARE CLAIMED AS A FEATURE OF THE MARK.

THE MARK CONSISTS OF THE WORDS "CREATING GROWTH SOLUTIONS FOR THE LOW CARBON ECONOMY" IN BLUE, WITH THE LETTER "O" IN THE WORD "GROWTH" AND THE LETTER "O" IN THE WORD "SOLUTIONS" IN GREEN.

CLASS 9—ELECTRICAL AND SCIENTIFIC APPARATUS

FOR ELECTRONIC PUBLICATIONS, NAMELY, BOOKS, MANUALS, REPORTS, PAPERS, MAGAZINES, JOURNALS, NEWS BULLETINS, PERIODICALS, CATALOGUES, BROCHURES AND AUDIO AND VIDEO RECORDINGS FEATURING INFORMATION, ANALYSIS AND COMMENTARY RELATED TO LOW-CARBON GROWTH AND SUSTAINABLE BUSINESS RECORDED ON COMPUTER MEDIA (U.S. CLS. 21, 23, 26, 36 AND 38).

CLASS 16—PAPER GOODS AND PRINTED MATTER

FOR BOOKS IN THE FIELD OF LOW-CARBON GROWTH AND SUSTAINABLE BUSINESS; PRINTED PUBLICATIONS, NAMELY, BOOKS, MANUALS, REPORTS, PAPERS, MAGAZINES, JOURNALS, NEWS BULLETINS, PERIODICALS, CATALOGUES, AND BROCHURES IN THE FIELD OF LOW-CARBON GROWTH AND SUSTAINABLE BUSINESS; PRINTED REPORTS FEATURING INFORMATION AND ANALYSIS RELATED TO LOW-CARBON GROWTH AND SUSTAINABLE BUSINESS; BROCHURES ABOUT LOW-CARBON GROWTH AND SUSTAINABLE BUSINESS; PRINTED PERIODICALS IN THE FIELD OF LOW-CARBON GROWTH AND SUSTAINABLE BUSINESS; PRINTED MATTER, NAMELY, BOOKS, MANUALS, REPORTS, PAPERS, MAGAZINES, JOURNALS, NEWS ITEMS, PERIODICALS, CATALOGUES, AND BROCHURES FEATURING INFORMATION, ANALYSIS AND COMMENTARY RELATED TO LOW-CARBON GROWTH AND SUSTAINABLE BUSINESS (U.S. CLS. 2, 5, 22, 23, 29, 37, 38 AND 50).

CLASS 35—ADVERTISING AND BUSINESS

FOR MARKET REPORTS AND STUDIES; MARKET RESEARCH SERVICES (U.S. CLS. 100, 101 AND 102).

CLASS 38—COMMUNICATION

FOR PROVIDING USER ACCESS TO A GLOBAL COMPUTER NETWORK AND THE INTERNET (U.S. CLS. 100, 101 AND 104).

CLASS 41—EDUCATION AND ENTERTAINMENT

FOR PUBLICATION OF BOOKS, MAGAZINES, JOURNALS, PERIODICALS, CATALOGUES, BROCHURES AND AUDIO AND VIDEO RECORDINGS; ELECTRONIC ON-LINE PUBLICATION OF PERIODICALS AND BOOKS; EDUCATIONAL SERVICES, NAMELY, ARRANGING AND CONDUCTING EDUCATIONAL CONFERENCES, CONGRESSES, SEMINARS AND WORKSHOPS IN THE FIELD OF LOW-CARBON GROWTH AND SUSTAINABLE BUSINESS; FILM AND VIDEO PRODUCTION; POST-PRODUCTION EDITING SERVICES IN THE FIELD OF MUSIC, VIDEOS AND FILM (U.S. CLS. 100, 101 AND 107).

EDWARD FENNESSY, EXAMINING ATTORNEY

CLASS 42—SCIENTIFIC AND COMPUTER SERVICES

FOR PLANNING AND BUILDING PLANNING CONSULTATION FOR BUILDING AND BUILDING CONSTRUCTIONS; SERVICES OF ENGINEERS; PREPARATION OF EXPERT REPORTS BY ENGINEERS OR LABORATORY TECHNICIANS, NAMELY, DRAWING UP OF EXPERT TECHNICAL OPINIONS IN CONNECTION WITH UNDERWATER DREDGING WORK; MATERIAL TESTING (U.S. CLS. 100 AND 101).

NAPOLEON SHARMA, EXAMINING ATTORNEY

SN 79-082,190. CACTUS CORPORATION, JAPAN, FILED 3-1-2010.



OWNER OF INTERNATIONAL REGISTRATION 1037636 DATED 3-1-2010, EXPIRES 3-1-2020.

OWNER OF U.S. REG. NO. 3,486,455.

THE NAME "G GARSON" DOES NOT IDENTIFY ANY LIVING INDIVIDUAL.

THE MARK CONSISTS OF THE STYLIZED WORDING "GARSON" ABOVE A CURVED WREATH DESIGN AND UNDER A BISECTED OVAL WITH THE LETTER "G" AND A HORIZONTAL LINE WITHIN.

SN 79-081,968. DAMEN DREDGING EQUIPEMENT B.V., NIJKERK, NETHERLANDS, FILED 2-15-2010.

DOP

THE MARK CONSISTS OF STANDARD CHARACTERS WITHOUT CLAIM TO ANY PARTICULAR FONT, STYLE, SIZE, OR COLOR.

OWNER OF INTERNATIONAL REGISTRATION 1037033 DATED 2-15-2010, EXPIRES 2-15-2020.

OWNER OF U.S. REG. NO. 2,897,265.

CLASS 7—MACHINERY

FOR MACHINES NOT INCLUDED IN OTHER CLASSES AND MACHINE TOOLS, PUMPS, NAMELY, SUBMERSIBLE DREDGE PUMPS, MINING PUMPS, PUMPS FOR MACHINES, AND PROCESSING PUMPS, NAMELY, PUMPS FOR USE IN PROCESSING SAND AND GRIT AND IN SOIL CLEANING INSTALLATIONS (U.S. CLS. 13, 19, 21, 23, 31, 34 AND 35).

CLASS 11—ENVIRONMENTAL CONTROL APPARATUS

FOR WATER PURIFICATION AND FILTRATION MACHINES FOR IRRIGATION AND DRAINAGE SYSTEMS (U.S. CLS. 13, 21, 23, 31 AND 34).

CLASS 37—CONSTRUCTION AND REPAIR

FOR CONSTRUCTION, MAINTENANCE AND REPAIR OF INDUSTRIAL AND ENGINEERING FACILITIES, NAMELY, BUILDINGS, SHIPS AND VESSELS IN THE NATURE OF PLATFORMS FOR DREDGING; BUILDING CONSTRUCTION IN THE NATURE OF LAYING CABLES AND PIPELINES FOR BUILDINGS; UNDERWATER DREDGING WORK CONSULTATION (U.S. CLS. 100, 103 AND 106).

CLASS 16—PAPER GOODS AND PRINTED MATTER

FOR INDUSTRIAL PACKAGING CONTAINERS OF PAPER; STATIONERY, CARDS FOR STATIONERY USE, POCKET MEMORANDUM BOOKS, PAPER IDENTIFICATION TAGS, DESK PADS, STICKERS FOR STATIONERY USE; DECORATIVE STICKERS; STICKERS, NAMELY, DECORATIVE STICKERS FOR AUTOMOBILES; DECORATIVE DECALS FOR VEHICLE WINDOWS; PICTURE POSTCARDS; CATALOGUES IN THE FIELD OF AUTOMOBILES, CLOTHING, BAGS, BELTS AND PERSONAL ORNAMENTS; CALENDARS; MAGAZINES IN THE FIELD OF AUTOMOBILES; PAMPHLETS IN THE FIELD OF AUTOMOBILES, CLOTHING, BAGS, BELTS AND PERSONAL ORNAMENTS; PHOTOGRAPH STANDS; CAR STICKERS (U.S. CLS. 2, 5, 22, 23, 29, 37, 38 AND 50).

CLASS 18—LEATHER GOODS

FOR FOLDING BRIEFCASES, SHOULDER BAGS, BRIEFCASES, SUITCASES, CARRY-ON BAGS, HANDBAGS, BOSTON BAGS, BACKPACKS; LEATHER SHOPPING BAGS, REUSABLE SHOPPING BAGS; KEY CASES; WALLETS NOT OF PRECIOUS METALS; BUSINESS CARD CASES; VANITY CASES, NOT FITTED (U.S. CLS. 1, 2, 3, 22 AND 41).

CLASS 35—ADVERTISING AND BUSINESS

FOR RETAIL STORE SERVICES AND WHOLESALE STORE SERVICES FEATURING AUTOMOBILES, CLOTHING, BAGS AND POUCHES, PERSONAL ARTICLES, TOBACCOS AND SMOKER'S ARTICLES; ADVERTISING; PROVIDING INFORMATION ON COMMERCIAL SALES BY TELEPHONE, FACSIMILE OR INTERNET (U.S. CLS. 100, 101 AND 102).

TASNEEM HUSSAIN, EXAMINING ATTORNEY

SN 79-082,247. INTERLAB. SAINT NOM LA BRETECHE, FRANCE, FILED 4-2-2010.

STOMA FILTER

THE MARK CONSISTS OF STANDARD CHARACTERS WITHOUT CLAIM TO ANY PARTICULAR FONT, STYLE, SIZE, OR COLOR.

OWNER OF INTERNATIONAL REGISTRATION 1037758 DATED 4-2-2010, EXPIRES 4-2-2020.

CLASS 9—ELECTRICAL AND SCIENTIFIC APPARATUS

FOR SCIENTIFIC, NAUTICAL, SURVEYING, ELECTRIC, PHOTOGRAPHIC, CINEMATOGRAPHIC, OPTICAL, WEIGHING, MEASURING, SIGNALING, CHECKING, EMERGENCY AND TEACHING APPARATUS AND INSTRUMENTS, NAMELY, ELECTRICAL GRIDING MACHINES AND MIXING MACHINES FOR USE AS LABORATORY EQUIPMENT, CAMERAS, FLAT PANEL DISPLAY SCREENS; LABORATORY APPARATUS, NAMELY, MICROBIOLOGICAL LAB SAMPLE BLENDER, SCALES, AUTOMATED DILUTERS FOR SOLID SAMPLES, AUTOMATED LABORATORY EQUIPMENT FOR PREPARING CULTURE MEDIA, NAMELY, BACTERIAL COLONY PICKING AND SEEDING MACHINES FOR INOCULATING A SUBSTRATE, MICROBIOLOGICAL LABORATORY SAMPLE BLENDERS, AUTOMATED FILLER FOR PIPETS OR AUTOMATIC DEVICES FOR PREPARING SAMPLE OR PETRI DISHES, PROGRAMMABLE PERISTALTIC PUMP; APPARATUS FOR RECORDING, TRANSMITTING AND REPRODUCING SOUND OR IMAGES, NAMELY, MAGNETICALLY ENCODED MICRO TAGS OF PLASTIC, METAL OR SILICATE FOR USE IN TRACING SAMPLES; AUTOMATIC VENDING MACHINES AND MECHANISMS FOR COIN-OPERATED APPARATUS; CASH REGISTERS; CALCULATING MACHINES AND DATA PROCESSING EQUIPMENT, NAMELY, TEMPERATURE MONITORS, MICROBIAL COLONY COUNTERS; FIRE EXTINGUISHERS (U.S. CLS. 21, 23, 26, 36 AND 38).

CLASS 10—MEDICAL APPARATUS

FOR SURGICAL, MEDICAL, DENTAL AND VETERINARY APPARATUS FOR USE IN GENERAL SURGERY, ARTIFICIAL LIMBS, EYES AND TEETH; ORTHOPEDIC ARTICLES, NAMELY, POST SURGERY ORTHOPEDIC SUPPORTS; SUTURE MATERIALS; MEDICAL BAGS DESIGNED TO HOLD MEDICAL SAMPLING OR SURGERY ELEMENTS FOR MIXERS AND FILTERS SOLD AS A UNIT (U.S. CLS. 26, 39 AND 44).

CHRISTINE MARTIN, EXAMINING ATTORNEY

SN 79-083,003. DALEBROOK SUPPLIES LTD, UNITED KINGDOM, FILED 3-30-2010.

Dalebrook

OWNER OF INTERNATIONAL REGISTRATION 1039938 DATED 3-30-2010, EXPIRES 3-30-2020.

THE WORDING "DALEBROOK" HAS NO MEANING IN A FOREIGN LANGUAGE.

CLASS 20—FURNITURE AND ARTICLES NOT OTHERWISE CLASSIFIED

FOR BARRELS, NOT OF METAL FOR FOOD FOR COMMERCIAL AND/OR INDUSTRIAL USE; BASKETS, NOT OF METAL; BINS, NOT OF METAL; BINS OF WOOD OR PLASTIC; CLOSURES, NOT OF METAL, FOR CONTAINERS; CONTAINERS, NON METAL CONTAINERS FOR STORAGE OR TRANSPORT; PACKAGING PLASTIC CONTAINERS; DECORATIONS OF PLASTIC FOR FOODSTUFFS; PACKAGING CONTAINERS OF PLASTIC; PEDESTALS FOR USE AS FLOWER POTS; PLACARDS OF WOOD OR PLASTICS; SCREWS, NOT OF METAL, TRAYS, NOT OF METAL (U.S. CLS. 2, 13, 22, 25, 32 AND 50).

CLASS 21—HOUSEWARES AND GLASS

FOR BASKETS, FOR DOMESTIC USE, OF PLASTIC OR WICKER; BASTING SPOONS, FOR KITCHEN USE; CANDY BOXES NOT OF PRECIOUS METAL; SOAP BOXES; BREAD BASKETS FOR DOMESTIC USE; BREAD BOARDS; CANDY BOXES, NOT OF PRECIOUS METAL; CERAMIC DINNERWARE, NAMELY, PLATES, BOWLS, CUPS AND SAUCERS; COASTERS, NOT OF PAPER AND OTHER THAN TABLE LINEN; COCKTAIL STIRRERS; CONTAINERS FOR HOUSEHOLD OR KITCHEN USE EXCEPT IN PRECIOUS METAL; COVERS FOR DISHES; CRUET STANDS FOR OIL AND VINEGAR, NOT OF PRECIOUS METAL; CRUETS, NOT OF PRECIOUS METAL; EGG CUPS; CUPS FOR FRUIT; CUPS, NOT OF PRECIOUS METAL; CUPS OF PAPER OR PLASTIC, CUTTING BOARDS FOR THE KITCHEN; DINNERWARE, NAMELY, PLATES, BEAKERS, NAMELY, WIDE-MOUTHED DRINKING CUPS FOR HOUSEHOLD USE, BOWLS CUPS AND SAUCERS; DISH COVERS; DISHES FOR SOAP, DISHES, NOT OF PRECIOUS METAL; EARTHENWARE BASINS; EARTHENWARE MUGS; EGG CUPS, NOT OF PRECIOUS METAL; FLOWER POTS; GOBLETS, NOT OF PRECIOUS METAL; COOKING UTENSILS, NAMELY, GRILLS, ICE BUCKETS, JUGS, NOT OF PRECIOUS METAL; KITCHEN CONTAINERS, NOT OF PRECIOUS METAL; KITCHEN MIXERS, NON-ELECTRIC; LAZY SUSANS; LUNCH BOXES; MENU CARD HOLDERS; MIXING CUPS; MIXING BOWLS; MANUAL COCKTAIL SHAKERS; MIXING SPOONS; MUGS, NOT OF PRECIOUS METAL; NAPKIN HOLDERS, NOT OF PRECIOUS METAL; NAPKIN RINGS, NOT OF PRECIOUS METAL; PEPPER POTS, NOT OF PRECIOUS METAL; LITTER BOXES AND TRAYS FOR PETS; PIE SERVERS; PITCHERS, NOT OF PRECIOUS METAL; PORCELAIN DINNERWARE, NAMELY, PLATES, BOWLS, MUGS, CUPS AND SAUCERS; POT LIDS, POTS, POTS, NOT OF PRECIOUS METAL; SALAD BOWLS, NOT OF PRECIOUS METAL; SALT CELLARS, NOT OF PRECIOUS METAL; SALT SHAKERS, NOT OF PRECIOUS METAL; SAUCERS, NOT OF PRECIOUS METAL; SCOOPS; SERVINGWARE FOR SERVING FOOD AND DRINKS; NOT OF PRECIOUS METAL; SALT SHAKERS; SOUP BOWLS, NOT OF PRECIOUS METAL; HOUSEHOLD UTENSILS, NAMELY, SPATULAS; SPOONS, FOR KITCHEN USE; STRAINERS FOR HOUSEHOLD PURPOSES, NOT OF PRECIOUS METAL; SUGAR BOWLS, NOT OF PRECIOUS METAL; TABLE PLATES, NOT OF PRECIOUS METAL; TABLE PLACE CARD HOLDERS NOT OF PRECIOUS METAL; TART SCOOPS; TEAPOTS, NOT OF PRECIOUS METAL; TRAYS FOR DOMESTIC PURPOSES, NOT OF PRECIOUS METAL; UTENSILS FOR HOUSEHOLD PURPOSES, NOT OF PRECIOUS METAL, NAMELY, TONGS, SPOONS AND LADLES; VASES, NOT OF PRECIOUS METAL; VEGETABLE SERVING DISHES (U.S. CLS. 2, 13, 23, 29, 30, 33, 40 AND 50).

GISELLE AGOSTO, EXAMINING ATTORNEY

SN 79-083,021. R.P.E. S.R.L., ITALY, FILED 4-1-2010.

SN 79-083,437. METAIO GMBH, FED REP GERMANY, FILED 3-15-2010.



PRIORITY DATE OF 10-22-2009 IS CLAIMED.

OWNER OF INTERNATIONAL REGISTRATION 1039983 DATED 4-1-2010, EXPIRES 4-1-2020.

THE COLOR(S) BLACK, SHADES OF ORANGE AND SHADES OF BLUE IS/ARE CLAIMED AS A FEATURE OF THE MARK.

THE MARK CONSISTS OF THE WORDING "RPE", WRITTEN IN PARTICULAR BLACK-COLOURED LOW-CASE LETTERS, WHICH IS PUT INSIDE A THIN AND BLACK-COLOURED FRAME, EVERYTHING UPON A PERSPECTIVE-LIKE BASIS, WHERE ITS LEFT SIDE IS BLUE-SHADED AND THE RIGHT SIDE IS ORANGE-SHADED; THESE TWO COLOURS GO FADING AWAY TOWARDS THE INNER PART OF THE BASIS.

CLASS 7—MACHINERY

FOR VALVES FOR USE WITH FLUIDS, NAMELY, ELECTRIC VALVES FOR PUMPS OR BEING PARTS OF MACHINES FOR CONTROLLING FLUID FLOW AND FOR OPENING AND CLOSING FLUID PASSAGE; VALVES FOR MEASURING FLUID FLOW, NAMELY, ELECTRIC VALVES AS MACHINE COMPONENTS FOR COUNTING QUANTITY OF FLUID (U.S. CLS. 13, 19, 21, 23, 31, 34 AND 35).

CLASS 9—ELECTRICAL AND SCIENTIFIC APPARATUS

FOR SOLENOID VALVES; DEVICES, NAMELY, CONTROL VALVES FOR REGULATING FLUID FLOW; FLOWMETERS; VALVES FOR CONTROLLING AND REGULATING FLOW OF LIQUIDS NOT BEING PARTS OF PLUMBING, HEATING, COOLING INSTALLATIONS OR MACHINES; FLOW REGULATORS FOR DOMESTIC, COMMERCIAL AND AGRICULTURAL USE (U.S. CLS. 21, 23, 26, 36 AND 38).

CLASS 11—ENVIRONMENTAL CONTROL APPARATUS

FOR PLUMBING AND IRRIGATION FITTINGS, NAMELY, WATER FLOW RATE REGULATORS AND WATER FLOW RESTRICTORS IN THE NATURE OF VALVES; STEAM VALVES, NAMELY, FLOW RATE REGULATORS AND FLOW RESTRICTORS; FLOW RATE REGULATORS AND FLOW RESTRICTORS FOR APPARATUS FOR HEATING, STEAM GENERATING, COOKING, REFRIGERATING, OR DRYING INSTALLATIONS, AND SANITARY APPARATUS AND INSTALLATIONS, HYDROMASSAGE TUBS, HYDROMASSAGE SHOWERS; VALVES, NAMELY, VALVES FOR DRIPPER IRRIGATION UNITS FOR USE WITH SPORTS GROUNDS, AGRICULTURAL AREAS, GARDENS, TERRACES, VERANDAS AND BALCONIES; PLUMBING FITTINGS, NAMELY, ELECTRIC VALVES FOR WATER AND SANITARY APPARATUS AND INSTALLATIONS, TAPS, HYDROMASSAGE TUBS, MULTI-FUNCTION HYDROMASSAGE SHOWERS, WATER AND DRINKS DISPENSERS, DRINK FILTRATORS, STEAM BOILERS, STEAM IRONS, ICE MACHINES, COFFEE MACHINES, APPARATUS FOR HEATING, STEAM GENERATING, COOKING, REFRIGERATING, DRYING; AGRICULTURAL IRRIGATION UNITS (U.S. CLS. 13, 21, 23, 31 AND 34).

GINA FINK, EXAMINING ATTORNEY

THE MARK CONSISTS OF STANDARD CHARACTERS WITHOUT CLAIM TO ANY PARTICULAR FONT, STYLE, SIZE, OR COLOR.

PRIORITY DATE OF 9-17-2009 IS CLAIMED.

OWNER OF INTERNATIONAL REGISTRATION 1041118 DATED 3-15-2010, EXPIRES 3-15-2020.

THE WORDING "JUNAIO" HAS NO MEANING IN A FOREIGN LANGUAGE.

CLASS 9—ELECTRICAL AND SCIENTIFIC APPARATUS

FOR COMPUTER SOFTWARE FOR PROVIDING AND PRESENTING LOCATION-BASED OR OBJECT-RELATED INFORMATION; COMPUTER SOFTWARE FOR PRODUCT VISUALIZATION FOR COMMERCIAL AND INDUSTRIAL USE; COMPUTER SOFTWARE FOR MAINTENANCE OF COMMERCIAL AND INDUSTRIAL PRODUCTS AND INSTALLATIONS; COMPUTER PROGRAMS, IN PARTICULAR, DATABASE PROGRAMS FOR USE IN INTEGRATING PRODUCT DATA AND SPECIFICATIONS FOR COMMERCIAL AND INDUSTRIAL USE; COMPUTER PROGRAMS, NAMELY, AUGMENTED REALITY PROGRAMS FOR COMMERCIAL AND INDUSTRIAL USE; COMPUTER PROGRAMS USED FOR AUTHORIZING PURPOSES FOR CREATING LOCATION BASED CONTENT AND AUGMENTED REALITY APPLICATIONS; COMPUTER PROGRAMS FOR DEVELOPING AND PROVIDING GEOGRAPHICAL INFORMATION SERVICES FOR INTERNET AND MOBILE DEVICES; COMPUTER PROGRAMS FOR DEVELOPING AND OPERATING NAVIGATION SYSTEMS FOR VEHICLES FOR COMMERCIAL, INDUSTRIAL, AND MILITARY USE; COMPUTER PROGRAMS FOR DEVELOPING AND OPERATING SIMULATION SYSTEMS FOR TRAINING; COMPUTER PROGRAMS, NAMELY, COMPUTER GAMES; RECORDED COMPUTER PROGRAMS FEATURING EDUCATIONAL PROGRAMS IN THE FIELD OF AUGMENTED REALITY, SCIENCE, CULTURE, HISTORY, GAMES, AND COMMISSIONING, MAINTENANCE AND TRAINING WITH RESPECT TO COMMERCIAL PRODUCTS OR INDUSTRIAL PRODUCTS AND PROCESSES; COMPUTER HARDWARE AND PARTS THEREOF; COMMUNICATION AND TELECOMMUNICATION APPARATUS AND INSTRUMENTS, NAMELY, PDAS, SMARTPHONES, TABLET PCS, HEAD-MOUNTED DISPLAYS, APPARATUS FOR TRANSMISSION OF COMMUNICATION AND MOBILE PHONES; SOFTWARE FOR UPLOADING, TRANSFERRING, PROCESSING AND ENLARGING MEDIA OBJECTS AND OTHER DIGITAL CONTENTS, INCLUDING TEXT, DOCUMENTS, PHOTOS, IMAGES, VIDEO AND SOUND, 3D MODELS AND 3D ANIMATIONS; COMPUTER SOFTWARE FOR TRANSFERRING SOUND AND IMAGES VIA COMMUNICATION NETWORKS; COMPUTER SOFTWARE FOR META DATA TAGGING AND WEBSITE TAGGING; APPARATUS FOR RECORDING, TRANSFERRING AND REPRODUCING SOUND AND IMAGES; DATA PROCESSING APPARATUS AND COMPUTERS, NAMELY, COMPUTERS AND COMPUTER SOFTWARE FOR TRANSFERRING AND SYNCHRONIZING DATA BETWEEN MOBILE COMMUNICATION APPARATUS; ELECTRONIC HAND APPARATUS, NAMELY, PDAS, SMARTPHONES, TABLET PCS, APPARATUS FOR TRANSMISSION OF COMMUNICATION, AND MOBILE PHONES FOR WIRELESS TRANSFER OF DATA AND/OR SPEECH SIGNALS; COMPUTER COMMUNICATION SOFTWARE FOR SYNCHRONIZING, TRANSFERRING AND COMMONLY USING DATA, INCLUDING DATA WITH RESPECT TO MAINTAINING AN ELECTRONIC CALENDAR, CONTENTS OF MESSAGES BETWEEN ONE OR MORE ELECTRONIC HAND

APPARATUS AND/OR DATA STORED IN A COMPUTER OR RELATED THERETO (U.S. CLS. 21, 23, 26, 36 AND 38).

CLASS 35—ADVERTISING AND BUSINESS

FOR ADVERTISING; PROVIDING INFORMATION IN TRADE AND BUSINESS MATTERS; CONSUMER ADVICE SERVICE, NAMELY, PROVIDING COMMERCIAL INFORMATION, ADVICE AND PRODUCT RECOMMENDATIONS FOR CONSUMERS; RENTAL OF ADVERTISING SPACE; DATA SEARCH IN COMPUTER FILES FOR THIRD PARTIES, NAMELY, SYSTEMIZATION OF DATA IN COMPUTER DATABASES DEPENDING ON CONTEXT INFORMATION AND PERSONAL RELEVANCE; DEMONSTRATING GOODS FOR ADVERTISING PURPOSES; PRICE COMPARISON SERVICES; COMPILATION OF INFORMATION IN COMPUTER DATABASES; DISTRIBUTION OF ADVERTISING MATERIAL; BUSINESS INFORMATION SERVICES; ONLINE ADVERTISING VIA A COMPUTER NETWORK; OPINION RESEARCH; PRODUCT PRESENTATION IN COMMUNICATION MEDIA FOR RETAIL PURPOSES; PUBLICATION OF ADVERTISING TEXTS; PUBLIC RELATIONS; UPDATING OF ADVERTISING MATERIAL; SALES PROMOTION FOR THIRD PARTIES; RENTAL OF ADVERTISING SPACE IN COMMUNICATION MEDIA (U.S. CLS. 100, 101 AND 102).

CLASS 38—COMMUNICATION

FOR TELECOMMUNICATIONS SERVICES, NAMELY, PROVIDING MULTIPLE USER ACCESS TO AN INTERNET PLATFORM FOR ELECTRONIC COMMERCE AND PROVIDING MULTIPLE USER ACCESS TO AN E-COMMERCE PLATFORM IN THE INTERNET; INTERNET SERVICES, NAMELY, PROVIDING MULTIPLE USER ACCESS TO INFORMATION ON THE INTERNET AND FOR TRANSFERRING INFORMATION, TEXTS, DRAWINGS AND IMAGES ON GOODS AND SERVICES IN THE INTERNET AND PROVIDING MULTIPLE USER ACCESS TO SEARCH ENGINES, NAMELY, SEARCH ENGINES PERMITTING A USER TO SEARCH FOR INFORMATION IN THE INTERNET OR IN ELECTRONIC DATABASES BY PROVIDING SEARCH CRITERIA IN THE FORM OF KEYWORDS, IMAGES OR LOCATIONS; TELEPHONE VOICE MESSAGING SERVICES, NAMELY, ACQUIRING, FORWARDING, PROCESSING OF TELEPHONE CALLS, TELEFAX MESSAGES, E-MAILS AND MESSAGES LEFT ON AN INTERNET HOMEPAGE; PROVIDING MULTIPLE USER ACCESS TO AN ONLINE TELECOMMUNICATIONS PLATFORM FOR ACCESSING AN INTERNET SHOPPING CHANNEL; PROVIDING MULTIPLE USER ACCESS TO THE INTERNET; PROVIDING ACCESS TO ELECTRONIC DATABASES IN COMPUTER NETWORKS; PROVIDING MULTIPLE USER ACCESS TO THE INTERNET FOR ACCESSING GPS NAVIGATION SERVICES IN THE INTERNET; EMAIL SERVICES; WIRELESS TELECOMMUNICATION SERVICES, IN PARTICULAR TELECOMMUNICATION SERVICES PERMITTING A USER TO TRANSMIT AND/OR RECEIVE MESSAGES VIA A WIRELESS DATA NETWORK; DATA TELECOMMUNICATION VIA THE INTERNET, NAMELY, TRANSFER OF DATA VIA TELECOMMUNICATIONS FOR UPLOADING, PUBLISHING, INDICATING, REPRODUCING, LABELING, BLOGGING, COMMONLY USING OR OTHER PROVIDING OF ELECTRONIC MEDIA OR INFORMATION; WEBCASTING; PROVIDING ONLINE DISCUSSION FORUMS AND ELECTRONIC COMMUNICATION PANELS IN THE NATURE OF CHAT ROOMS AND ELECTRONIC MESSAGE BOARDS AND INTERNET FORUMS ALL FOR THE TRANSMISSION OF MESSAGES IN THE FIELD OF TOPICS OF GENERAL INTEREST, AUGMENTED REALITY, PRODUCT INFORMATION, CULTURAL EVENTS, POINTS OF INTERESTS AND FOR TRANSFERRING MESSAGES, IMAGES, SOUND, GEOGRAPHIC INFORMATION, GEO TAGGING AND OTHER DATA BETWEEN COMPUTER USERS; PROVISION OF ACCESS TO DATA OR DOCUMENTS IN THE NATURE OF DIGITAL IMAGES STORED ELECTRONICALLY IN CENTRAL FILES FOR REMOTE CONSULTATION; WIRELESS TRANSFER OF DATA, NAMELY, SERVICES PERMITTING THE USER TO TRANSMIT AND/OR RECEIVE MESSAGES VIA A WIRELESS DATA NETWORK BY USING A PORTABLE ELECTRONIC POCKET DEVICE; TELECOMMUNICA-

TION SERVICES, NAMELY, TRANSMISSION AND RECEIVING OF SPEECH COMMUNICATION VIA A WIRELESS DATA NETWORK BY USING A PORTABLE ELECTRONIC POCKET DEVICE; BROADCASTING RADIO AND TELEVISION PROGRAMS; NEWS AGENCIES, NAMELY, TRANSMISSION OF NEWS ITEMS TO NEWS REPORTING ORGANIZATIONS; PROVIDING OF MOBILE AND STATIONARY TELECOMMUNICATION CHANNELS AND COMMUNICATION VIA MOBILE TELEPHONE; SPEECH COMMUNICATION SERVICES VIA MOBILE TELEPHONES OR OTHER MOBILE DEVICES; DATA TELECOMMUNICATION SERVICES, NAMELY, TRANSFER OF DATA BY RADIO, TELECOMMUNICATION AND SATELLITE; PROVIDING ACCESS TO A GLOBAL COMPUTER NETWORK FOR DOWNLOADING COMPUTER SOFTWARE, COMPUTER PROGRAMS AND INFORMATION; E-MAIL SERVICES; PROVIDING MULTIPLE USER ACCESS TO DATA IN THE INTERNET; PROVIDING MULTI-USER ACCESS TO A WORLDWIDE COMPUTER INFORMATION NETWORK; PROVIDING ACCESS TO INFORMATION STORED ELECTRONICALLY IN CENTRAL FILES FOR REMOTE CONSULTATION; PROVIDING INFORMATION AND ADVICE WITH RESPECT TO THE AFOREMENTIONED SERVICES VIA THE INTERNET AND OTHER ELECTRONIC NETWORKS; ELECTRONIC TRANSMISSION OF IMAGES IN THE NATURE OF PHOTOS; RENTAL OF ACCESS TIMES TO DATABASES AVAILABLE ON GLOBAL COMPUTER NETWORKS (U.S. CLS. 100, 101 AND 104).

CLASS 41—EDUCATION AND ENTERTAINMENT

FOR EDUCATION SERVICES, NAMELY, PROVIDING WORKSHOPS, SEMINARS, AND ELECTRONIC TUTORIALS IN THE FIELD OF AUGMENTED REALITY, VISUAL SEARCH, DEVELOPMENT OF MOBILE AUGMENTED REALITY APPLICATIONS FOR THE FIELDS OF ENTERTAINMENT, INDUSTRY, COMMERCE, GAMING AND EDUCATION, AND LOCATION-BASED PROVISION OF INFORMATION; EDUCATION SERVICES, NAMELY, PROVIDING TRAINING ON THE SUBJECT OF AUGMENTED REALITY, VISUAL SEARCH, DEVELOPMENT OF MOBILE AUGMENTED REALITY APPLICATIONS FOR THE FIELDS OF ENTERTAINMENT, INDUSTRY, COMMERCE, GAMING AND EDUCATION, AND LOCATION-BASED PROVISION OF INFORMATION; ENTERTAINMENT SERVICES, NAMELY, PROVIDING ONLINE COMPUTER GAMES IN MOBILE WIRELESS FORM AND PROVIDING ONLINE LOCATION-BASED COMPUTER GAMES, ARRANGING AND CONDUCTING LIVE INTERACTIVE SCAVENGER HUNT GAMING ADVENTURES; ENTERTAINMENT SERVICES, NAMELY, PROVIDING INFORMATION IN THE FIELDS OF EDUCATIONAL AND CULTURAL SPECIAL EVENTS AND FESTIVALS, LEISURE ACTIVITIES, HISTORY, EDUCATION AND BOOKING OF SEATS FOR PERFORMANCES; PROVISION OF NON-DOWNLOADABLE ELECTRONIC PUBLICATIONS IN THE NATURE OF ELECTRONIC BOOKS, MAGAZINE, JOURNALS, MANUALS, AND ARTICLES ON THE SUBJECT OF AUGMENTED REALITY, VISUAL SEARCH, DEVELOPMENT OF MOBILE AUGMENTED REALITY APPLICATIONS FOR THE FIELDS OF ENTERTAINMENT, INDUSTRY, COMMERCE, GAMING AND EDUCATION, AND LOCATION-BASED PROVISION OF INFORMATION FEATURING INFORMATION ON VIRTUAL COMMUNITIES, SOCIAL NETWORKS, LOCATIONS AND/OR BUSINESSES; PUBLISHING PRINT MEDIA IN THE NATURE OF PRINTED MATTER NOT FOR ADVERTISING PURPOSES ON THE SUBJECT OF AUGMENTED REALITY, VISUAL SEARCH, DEVELOPMENT OF MOBILE AUGMENTED REALITY APPLICATIONS FOR THE FIELDS OF ENTERTAINMENT, INDUSTRY, COMMERCE, GAMING AND EDUCATION, AND LOCATION-BASED PROVISION OF INFORMATION FEATURING INFORMATION ON VIRTUAL COMMUNITIES, SOCIAL NETWORKS, LOCATIONS AND/OR BUSINESSES; PHOTOGRAPHY SERVICES; ONLINE PUBLICATION OF PHOTOGRAPHS FOR THE SHARING OF PHOTOGRAPHS, NAMELY, ONLINE PUBLISHING OF DIGITAL PHOTOGRAPHS; ONLINE PUBLISHING OF PUBLICATIONS IN THE FORM OF ELECTRONIC BOOKS, MAGAZINES, NEWSPAPERS; ONLINE PROVIDING OF INTERACTIVE COMPUTER GAMES VIA COMPUTER NETWORKS AND WORLDWIDE COMMUNICATION NETWORKS; PROVIDING INFORMATION

IN THE FIELDS OF ENTERTAINMENT, MOTION PICTURES, MUSIC, SPORTS AND EDUCATION VIA COMPUTER NETWORKS AND GLOBAL COMMUNICATION NETWORKS; PROVIDING ENTERTAINMENT INFORMATION; PROVIDING EDUCATION INFORMATION; PROVIDING ALL AFOREMENTIONED SERVICES VIA THE INTERNET AND OTHER ELECTRONIC NETWORKS (U.S. CLS. 100, 101 AND 107).

CLASS 42—SCIENTIFIC AND COMPUTER SERVICES

FOR DESIGN AND DEVELOPMENT OF COMPUTERS AND COMPUTER PROGRAMS, IN PARTICULAR FOR MOBILE, COMPUTER-ASSISTED INFORMATION SYSTEMS; TECHNICAL SUPPORT AND CONSULTING SERVICES PERTAINING TO THE DEVELOPMENT OF DATA PROCESSING PROGRAMS, NAMELY, MAINTENANCE, ADJUSTING AND UPDATING OF COMPUTER PROGRAMS; RENTAL OF COMPUTER SOFTWARE FOR UTILIZATION VIA ELECTRONIC DATA NETWORKS, IN PARTICULAR THE INTERNET; TECHNICAL DEVELOPMENT AND ADVISORY SERVICES IN THE FIELD OF MECHANICAL ENGINEERING, AUTOMOTIVE ENGINEERING AND AERONAUTICAL ENGINEERING; TECHNOLOGY ADVICE PROVIDED TO INTERNET USERS, DATABASE USERS AND USERS OF NEW MEDIA BY MEANS OF A SUPPORT HOTLINE, USER HELPDESK, EMAIL OR AN ONLINE FORUM; PROVIDING ELECTRONIC VERIFICATION OF ONLINE ORDERS OF DIGITAL CONTENT AND GENERATING ELECTRONIC PERMISSION CODES WHICH THEN ALLOW USERS TO ACCESS SAID DIGITAL CONTENT IN THE NATURE OF PICTURES AND TO DISPLAY THE SAME ONLINE WITH TAGS; PROVIDING INFORMATION AND ADVICE WITH RESPECT TO THE AFOREMENTIONED SERVICES (U.S. CLS. 100 AND 101).

LINDA ESTRADA, EXAMINING ATTORNEY

CLASS 38—COMMUNICATION

FOR PROVIDING ACCESS TO ENTERTAINMENT, GAMES AND EDUCATIONAL APPLICATIONS, NAMELY, ONLINE MULTIPLAYER GAMES VIA THE INTERNET; PROVIDING ACCESS TO ELECTRONIC BULLETIN BOARDS AND CHAT ROOMS USED IN OR RELATED TO PLAYING ONLINE COMPUTER GAMES; ELECTRONIC TRANSMISSION AND BROADCASTING OF DATA OVER THE INTERNET AND MOBILE TELEPHONE NETWORKS; ELECTRONIC MAIL SERVICES; PROVIDING ELECTRONIC INTERNET CHAT ROOMS AND ELECTRONIC BULLETIN BOARD SERVICES USED IN OR RELATED TO PLAYING ONLINE COMPUTER GAMES; PROVISION OF ADVICE, CONSULTANCY AND INFORMATION REGARDING ALL OF THE AFORESAID SERVICES (U.S. CLS. 100, 101 AND 104).

CLASS 41—EDUCATION AND ENTERTAINMENT

FOR ENTERTAINMENT SERVICES, NAMELY, PROVIDING ONLINE MULTIPLAYER COMPUTER GAMES BY MEANS OF COMMUNICATIONS NETWORKS; ENTERTAINMENT SERVICES, NAMELY, PROVIDING ONLINE MULTIPLAYER ELECTRONIC COMPUTER GAMES (U.S. CLS. 100, 101 AND 107).

COLLEEN DOMBROW, EXAMINING ATTORNEY

SN 79-084,118. SOCIETY WITH LIMITED LIABILITY; "TRADING-PRODUCTION ASSOCIATION; "AMTEL", RU-141070 MOSCOW REGION, RUSSIAN FED., FILED 1-13-2010.

Русица

OWNER OF INTERNATIONAL REGISTRATION 1042936 DATED 1-13-2010, EXPIRES 1-13-2020.

THE MARK CONSISTS OF A FANTASY VERBAL DESIGNATION EXECUTED IN CYRILLIC.

THE NON-LATIN CHARACTERS IN THE MARK TRANSLITERATE TO "RUSITSA", THE TRANSLITERATED TERM HAS NO MEANING IN THE RUSSIAN LANGUAGE.

SN 79-083,731. JUNEHUD AB, SWEDEN, FILED 5-17-2010.

MILMO

THE MARK CONSISTS OF STANDARD CHARACTERS WITHOUT CLAIM TO ANY PARTICULAR FONT, STYLE, SIZE, OR COLOR.

PRIORITY DATE OF 11-17-2009 IS CLAIMED.

OWNER OF INTERNATIONAL REGISTRATION 1041976 DATED 5-17-2010, EXPIRES 5-17-2020.

CLASS 9—ELECTRICAL AND SCIENTIFIC APPARATUS

FOR DATA PROCESSING EQUIPMENT AND COMPUTERS FOR EXECUTING COMPUTER GAME SOFTWARE; COMPUTER GAME SOFTWARE; VIRTUAL REALITY GAME SOFTWARE; COMPUTER, VIDEO AND TELEVISION SOFTWARE GAMES; GAME SOFTWARE FOR COMMUNICATION DEVICES (U.S. CLS. 21, 23, 26, 36 AND 38).

CLASS 32—LIGHT BEVERAGES

FOR APERITIFS, NON-ALCOHOLIC; AERATED WATER, LITHIA WATER, MINERAL WATER AS A BEVERAGE, SELTZER WATER, SODA WATER, TABLE WATERS, KVASS; COCKTAILS, NON-ALCOHOLIC; LEMONADES; MILK OF PEANUTS FOR BEVERAGES; NON-ALCOHOLIC BEVERAGES, NAMELY, NON-ALCOHOLIC CIDER; ISOTONIC BEVERAGES; NON-ALCOHOLIC HONEY-BASED BEVERAGES; WHEY BEVERAGES; NON-ALCOHOLIC FRUIT JUICE BEVERAGES; MILK OF ALMONDS AS A BEVERAGE; FRUIT NECTARS, NON-ALCOHOLIC; ORGEAT SYRUP FOR USE AS A FLAVORING IN NON-ALCOHOLIC BEVERAGES; BEER, GINGER ALE, GINGER BEER, MALT BEER; POWDERS FOR EFFERVESCING BEVERAGES; SARSAPARILLA; SYRUPS FOR LEMONADE; SYRUPS FOR BEVERAGES; TOMATO JUICE AS A BEVERAGE; CIDER, NON-ALCOHOLIC; VEGETABLE JUICES AS BEVERAGES; FRUIT JUICES, FRUIT JUICE; PREPARATIONS FOR MAKING BEVERAGES, NAMELY, FRUIT DRINKS; UNFERMENTED MUST; GRAPE MUST, UNFERMENTED; BEER WORT; MALT WORT; PASTILLES FOR EFFERVESCING BEVERAGES; SHERBETS AS A BEVERAGE, SORBETS IN THE NATURE OF BEVERAGES; NON-ALCOHOLIC FRUIT EXTRACTS FOR MAKING BEVERAGES; EXTRACTS OF HOPS FOR MAKING BEER; ESSENCES FOR MAKING SOFT DRINKS NOT IN THE NATURE OF ESSENTIAL OILS (U.S. CLS. 45, 46 AND 48).

CLASS 33—WINES AND SPIRITS

FOR APERITIFS; ARAK; BRANDY; WINE; WINE, NAMELY, PIQUETTE; WHISKY; ANISETTE, KIRSCH, VODKA; GIN; LIQUEUR AND SPIRITS; COCKTAILS; ANISE LIQUEURS, CURACAO, LIQUEURS; ALCOHOLIC BEVERAGES EXCEPT BEER; ALCOHOLIC BEVERAGES CONTAINING FRUIT; SPIRITS AS BEVERAGES; DISTILLED SPIRITS; HYDROMEL AS MEAD; PEPPERMINT LIQUEURS; ALCOHOLIC BITTERS; RUM; SAKE; HARD CIDER, PERRY; DISTILLED SPIRITS OF RICE; ALCOHOLIC EXTRACTS; ALCOHOLIC FRUIT EXTRACTS; ALCOHOLIC ESSENCES (U.S. CLS. 47 AND 49).

ALLISON HOLTZ, EXAMINING ATTORNEY

SN 79-085,230. AGOLIN SA, BIÈRE, SWITZERLAND, FILED 6-29-2010.

AGOLIN

THE MARK CONSISTS OF STANDARD CHARACTERS WITHOUT CLAIM TO ANY PARTICULAR FONT, STYLE, SIZE, OR COLOR.

PRIORITY DATE OF 6-4-2010 IS CLAIMED.

OWNER OF INTERNATIONAL REGISTRATION 1045503 DATED 6-29-2010, EXPIRES 6-29-2020.

THE WORDING "AGOLIN" HAS NO MEANING IN A FOREIGN LANGUAGE.

CLASS 5—PHARMACEUTICALS

FOR VETERINARY PREPARATIONS FOR RUMINANTS AND MONOGASTRIC ANIMALS FOR ORAL TREATMENTS; DIETETIC SUBSTANCES ADAPTED FOR MEDICAL USE, NAMELY, DIETETIC FOODS ADAPTED FOR MEDICAL USE (U.S. CLS. 6, 18, 44, 46, 51 AND 52).

CLASS 31—NATURAL AGRICULTURAL PRODUCTS

FOR FOODSTUFFS FOR ANIMALS; FOODSTUFFS FOR ANIMALS, NAMELY, NON-MEDICATED FEED ADDITIVES AND PREMIXTURES (U.S. CLS. 1 AND 46).

CLASS 44—MEDICAL, BEAUTY AND AGRICULTURAL SERVICES

FOR VETERINARY SERVICES; HYGIENIC AND BEAUTY CARE FOR HUMAN BEINGS OR ANIMALS (U.S. CLS. 100 AND 101).

HELENE LIWINSKI, EXAMINING ATTORNEY

SN 79-085,477. URBOTICA, S.L., BARCELONA, SPAIN, FILED 4-13-2010.

URBOTICA The City Operating System

THE MARK CONSISTS OF STANDARD CHARACTERS WITHOUT CLAIM TO ANY PARTICULAR FONT, STYLE, SIZE, OR COLOR.

PRIORITY DATE OF 11-24-2009 IS CLAIMED.

OWNER OF INTERNATIONAL REGISTRATION 1046114 DATED 4-13-2010, EXPIRES 4-13-2020.

NO CLAIM IS MADE TO THE EXCLUSIVE RIGHT TO USE "CITY OPERATING SYSTEM", APART FROM THE MARK AS SHOWN.

CLASS 35—ADVERTISING AND BUSINESS

FOR PROCUREMENT SERVICES FOR THIRD PARTIES, SPECIFICALLY PROCUREMENT OF TECHNICAL EQUIPMENT AND SOFTWARE SYSTEMS FOR MONITORING AND MANAGING THE PHYSICAL AND ELECTRONIC DEMANDS AND USAGES OF URBAN CENTERS AND CITIES, INCLUDING HARDWARE AND COMMUNICATIONS SYSTEMS; IMPORT AND RETAIL STORE SERVICES AND ONLINE RETAIL STORES FEATURING HARDWARE, SOFTWARE, AND COMMUNICATIONS SYSTEMS WHICH MONITOR, TRACK, AND MANAGE PHYSICAL AND ELECTRONIC DEMANDS OF CITIES AND URBAN SPACES; RECORDING, TRANSCRIPTION, COMPOSITION, COMPILATION OR SYSTEMIZATION OF WRITTEN COMMUNICATIONS AND DATA; COMPILATION AND SYSTEMIZATION OF DATA IN A CENTRAL COMPUTER; COMPUTER FILE MANAGEMENT (U.S. CLS. 100, 101 AND 102).

CLASS 38—COMMUNICATION

FOR TELECOMMUNICATIONS SERVICES, SPECIFICALLY THE TRANSMISSION OF VOICE, DATA, GRAPHICS, IMAGES, AUDIO AND VIDEO VIA TELECOMMUNICATIONS NETWORKS, WIRELESS TELECOMMUNICATIONS NETWORKS AND THE INTERNET (U.S. CLS. 100, 101 AND 104).

CLASS 42—SCIENTIFIC AND COMPUTER SERVICES

FOR SCIENTIFIC AND TECHNOLOGICAL SERVICES AND RESEARCH AND DESIGN RELATING THERETO IN THE FIELD OF MONITORING AND MANAGEMENT OF COMMUNICATIONS SYSTEMS IN URBAN SPACES, NAMELY, MONITORING SENSORS, DATA COLLECTORS, AND ACTIVATORS TO MONITOR URBAN ACTIVITIES, NAMELY, ENERGY USAGE, AND SEWER SYSTEM, WATER AND UTILITY USAGE; INDUSTRIAL ANALYSIS AND RESEARCH SERVICES IN THE FIELD OF MONITORING AND MANAGING COMMUNICATIONS SYSTEMS IN URBAN SPACES; INDUSTRIAL RESEARCH IN THE NATURE OF TECHNICAL PROJECT STUDIES, PARTICULARLY FOR SYSTEMS FOR MONITORING ENERGY, WATER AND UTILITY USAGE, MANAGING ENERGY, WATER AND UTILITY USAGE, AND COMMUNICATION IN URBAN SPACES; CONSTRUCTION CONSULTANCY; CONSTRUCTION DRAFTING; COMPUTER HARDWARE AND SOFTWARE DESIGN AND DEVELOPMENT; COMPUTER SYSTEMS ANALYSIS FOR THE INSTALLATION OF COMPUTER SYSTEMS (U.S. CLS. 100 AND 101).

SARA BENJAMIN, EXAMINING ATTORNEY

SN 79-085,573. THE CROWN IN RIGHT OF THE STATE OF VICTORIA, REPRESENTED BY AND ACTING THROUGH THE DEPARTMENT, THE DEPARTMENT OF EDUCATION AND EARLY CHILDHOOD DEVELOPMENT, EAST MELBOURNE, AUSTRALIA, FILED 7-14-2010.



PRIORITY DATE OF 1-15-2010 IS CLAIMED.
OWNER OF INTERNATIONAL REGISTRATION 1046364 DATED 7-14-2010, EXPIRES 7-14-2020.
THE MARK CONSISTS OF A DESIGN OF A MAGNIFYING GLASS. TO THE RIGHT OF THE MAGNIFYING GLASS, A DESIGN OF A GEM STONE APPEARS, WITH THE TERM "E5" WITH THE NUMERAL "5" IN SUPERSCRIPT ON THE TOP OF THE GEM STONE.

CLASS 9—ELECTRICAL AND SCIENTIFIC APPARATUS

FOR DOWNLOADABLE PUBLICATIONS AND PRINTED MATERIAL PROVIDED OVER THE INTERNET, ONLINE OR THROUGH ANY COMPUTER OR COMMUNICATIONS NETWORK, NAMELY, BOOKS IN THE FIELD OF TEACHING ELEMENTARY EDUCATION; COMPUTERS AND COMPUTER SOFTWARE FOR CREATING TEACHER LESSON PLANS IN THE FIELD OF EDUCATION AND TRAINING, COMPACT DISCS AND CD-ROMS FEATURING SUBJECT MATTER IN THE FIELD OF TEACHING ELEMENTARY EDUCATION; AUDIO AND AUDIOVISUAL, INTERACTIVE AND MULTIMEDIA RECORDINGS AND MATERIALS, NAMELY, DVDS FEATURING MATTER IN THE FIELD OF TEACHING ELEMENTARY EDUCATION AND CREATING TEACHER LESSON PLANS; USER MANUALS AND GUIDES SOLD AS A UNIT THEREWITH; TEACHING APPARATUS AND INSTRUMENTS, NAMELY, EDUCATIONAL DVDS FEATURING TEACHING OF ELEMENTARY EDUCATION (U.S. CLS. 21, 23, 26, 36 AND 38).

CLASS 16—PAPER GOODS AND PRINTED MATTER

FOR PRINTED MATTER AND PUBLICATIONS, NAMELY, BOOKS, MANUALS, JOURNALS, NEWSLETTERS AND BOOKLETS IN THE FIELD OF TEACHING ELEMENTARY EDUCATION AND CREATING TEACHER LESSON PLANS, STATIONERY, STICKERS, POSTERS; PRINTED INSTRUCTIONAL AND TEACHING MATERIALS IN THE FIELD OF TEACHING ELEMENTARY EDUCATION AND CREATING TEACHER LESSON PLANS (U.S. CLS. 2, 5, 22, 23, 29, 37, 38 AND 50).

CLASS 41—EDUCATION AND ENTERTAINMENT

FOR EDUCATIONAL AND INSTRUCTIONAL SERVICES, NAMELY, SEMINARS AND COURSES IN THE FIELD OF TEACHING ELEMENTARY EDUCATION AND CREATING TEACHER LESSON PLANS; TRAINING SERVICES IN THIS CLASS, NAMELY, TEACHER TRAINING SERVICES; INFORMATION SERVICES RELATING TO EDUCATION; VOCATIONAL GUIDANCE SERVICES; EDUCATION CONSULTANCY SERVICES IN THE FIELD OF ELEMENTARY EDUCATION; ARRANGING AND CONDUCTING EDUCATIONAL COMPETITIONS, EXHIBITIONS, WORKSHOPS, SEMINARS AND CONFERENCES IN THE FIELD OF TEACHING ELEMENTARY EDUCATION; PUBLICATION OF EDUCATIONAL MATERIALS AND TEXTS IN THE NATURE OF NEWSLETTERS IN ELECTRONIC AND NON ELECTRONIC FORMAT, INCLUDING VIA AN ONLINE FACILITY AND ANY COMPUTER OR COMMUNICATIONS NETWORK IN THE FIELD OF TEACHING ELEMENTARY EDUCATION; PRODUCTION, PUBLICATION AND DISSEMINATION OF EDUCATIONAL AUDIOVISUAL PROGRAMS IN THE FIELD OF TEACHING ELEMENTARY EDUCATION (U.S. CLS. 100, 101 AND 107).

MARILYN IZZI, EXAMINING ATTORNEY

SN 79-085,679. SIX SWISS EXCHANGE AG, ZÜRICH, SWITZERLAND, FILED 11-12-2009.

SMI

THE MARK CONSISTS OF STANDARD CHARACTERS WITHOUT CLAIM TO ANY PARTICULAR FONT, STYLE, SIZE, OR COLOR.

OWNER OF INTERNATIONAL REGISTRATION 0863313 DATED 7-8-2005, EXPIRES 7-8-2015.

OWNER OF U.S. REG. NOS. 1,952,155, 2,608,847 AND 3,098,399.

CLASS 9—ELECTRICAL AND SCIENTIFIC APPARATUS

FOR DOWNLOADABLE DATA FILES, DATABASES, TEXT FILES AND ELECTRONIC PUBLICATIONS IN THE NATURE OF SPREADSHEETS, TEXT FILES AND FACT SHEETS, ALL THE FOREGOING FEATURING INFORMATION IN THE FIELD OF STOCKS, STOCK EXCHANGE, STOCK EXCHANGE INDICES AND FINANCIAL INSTRUMENTS (U.S. CLS. 21, 23, 26, 36 AND 38).

CLASS 35—ADVERTISING AND BUSINESS

FOR SERVICES COMPRISING THE INPUTTING, RECORDING, TRANSCRIPTION, COMPOSITION, COMPILATION AND SYSTEMIZATION OF DATA IN THE NATURE OF FINANCIAL INFORMATION, STOCK EXCHANGE AND BUSINESS INFORMATION; SERVICES COMPRISING THE RECORDING, COMPILATION, AND SYSTEMIZATION OF DATA IN THE NATURE OF STOCK EXCHANGE AND FINANCIAL INDICES AND OTHER ECONOMIC INDICES; PROVIDING INFORMATION ON COMMERCIAL MARKETS, NAMELY, ON STOCK EXCHANGE MARKETS FOR BUSINESS PURPOSES (U.S. CLS. 100, 101 AND 102).

CLASS 36—INSURANCE AND FINANCIAL

FOR FINANCIAL DETERMINATION AND CALCULATION OF INDICES PERTAINING TO STOCK EXCHANGE SECURITIES, AND FINANCIAL SECURITIES; PROVISION OF INFORMATION ON STOCK MARKETS; FINANCIAL SERVICES, NAMELY, FINANCIAL RESEARCH, DEVELOPMENT, CONSULTING AND TRACKING IN CONNECTION WITH STOCK EXCHANGE INDEXES; FINANCIAL SERVICES, NAMELY, CALCULATION AND MAINTENANCE OF SHARE INDICES; PROVISION OF INFORMATION AND DATA CONCERNING STOCK EXCHANGES; DEVELOPMENT OF STOCK EXCHANGE INDICES; CREATING, DEVELOPING AND ISSUING FINANCIAL INSTRUMENTS, NAMELY, SECURITIES, OPTIONS, BONDS, FUTURES, FORWARD CONTRACTS AND EXCHANGE TRADED FUNDS (U.S. CLS. 100, 101 AND 102).

CLASS 41—EDUCATION AND ENTERTAINMENT

FOR PUBLICATION OF SPREADSHEETS, TEXT FILES AND FACT SHEETS FEATURING STOCK EXCHANGE INDEX FIGURES, SECURITIES AND INFORMATION CONCERNING STOCK EXCHANGE INDICES, AND DATA, NAMELY, INDICES RELATED TO STOCK EXCHANGE MATTERS, SECURITIES, FINANCIAL INSTRUMENTS, COMPANIES, MARKETS AND UNDERLYING ECONOMIC REALITIES; PUBLICATION OF SPREADSHEETS, TEXT FILES AND FACT SHEETS FEATURING INDICES RELATED TO STOCK EXCHANGE MATTERS; PROVIDING ONLINE NON-DOWNLOADABLE ELECTRONIC PUBLICATIONS, NAMELY, SPREADSHEETS, GRAPHICS, TEXT FILES AND FACT SHEETS IN THE FIELD OF STOCK EXCHANGE (U.S. CLS. 100, 101 AND 107).

JEAN IM, EXAMINING ATTORNEY

CLASS 7—MACHINERY

FOR MACHINES AND INDUSTRIAL ROBOTS USED FOR PROCESSING OF WOOD, METAL, GLASS, PLASTICS AND MACHINE TOOLS; WORKING MACHINES AND ROBOTIC MECHANISMS, NAMELY, ROBOTIC ARMS AND INDUSTRIAL ROBOTS FOR PROCESSING OF WOOD, METAL, GLASS AND PLASTICS, AND MACHINE TOOLS; LIFTING, CARRYING AND TRANSFERRING MACHINES, ROBOTIC MECHANISMS, NAMELY, ROBOTIC ARMS AND INDUSTRIAL ROBOTS FOR LIFTING, CARRYING AND TRANSFERRING; ELEVATORS, MOVING STAIRS, WINCHES; MACHINES USED FOR AGRICULTURAL, NAMELY, CULTIVATORS, HARVESTERS, DISK HARROWS, SEEDERS AND MACHINES FOR THE PROCESSING OF CEREALS, FRUITS, VEGETABLES AND FOODS AND STOCK-BREEDING PURPOSES; ROBOTIC MECHANISMS, NAMELY, ROBOTIC ARMS AND INDUSTRIAL ROBOTS USED FOR AGRICULTURAL AND FOR THE PROCESSING OF CEREALS, FRUITS, VEGETABLES AND FOODS AND STOCKBREEDING PURPOSES; MOTORS AND MACHINES, NAMELY, ENGINES OTHER THAN THOSE FOR LAND VEHICLES, ELECTRICAL MOTORS AND PARTS THEREOF; BALL BEARINGS AND ROLLER BEARINGS FOR MACHINES; WHEEL REMOVING AND MOUNTING MACHINES; ALTERNATORS; GENERATORS, NAMELY, ELECTRICITY GENERATORS, AND GENERATORS DRIVEN BY SOLAR ENERGY; PAINTING MACHINES, AUTOMATIC PAINT INJECTION GUNS, ELECTRIC STAPLE MACHINES AND GUNS, ELECTRIC ADHESIVE GUNS, PRESSURED AIR OR LIQUID ATOMIZER GUNS FOR MACHINES; MANUAL ELECTRIC DRILLERS, MANUAL MOTOR SAWS, CUTTING MACHINES, SPIRAL MACHINES, PRESSURED AIR PRODUCERS, COMPRESSORS, NAMELY, GAS COMPRESSORS, AIR COMPRESSORS, AND ELECTRIC COMPRESSORS, VEHICLE WASHING MACHINE AND ROBOTIC MECHANISMS, NAMELY, ROBOTIC ARMS AND INDUSTRIAL ROBOTS FOR WASHING VEHICLES; ELECTRIC WELDING MACHINES AND ROBOTIC MECHANISMS, NAMELY, ROBOTIC ARMS AND INDUSTRIAL ROBOTS FOR WELDING; PRINTING MACHINES; PACKAGING MACHINES, FILLING, PLUGGING AND CLOSING MACHINES, LABELING MACHINES, CLASSIFICATION MACHINES AND ROBOTS AND ROBOTIC MECHANISMS, NAMELY, ROBOTIC ARMS, INDUSTRIAL ROBOTS FOR PACKAGING, FILLING, PLUGGING AND CLOSING, LABELING, AND CLASSIFICATION; TEXTILE MACHINES, NAMELY, TEXTILE WASHING MACHINES AND TEXTILE DYEING MACHINES, SWING MACHINES FOR HANDLING TEXTILES, AND INDUSTRIAL ROBOTS FOR MANUFACTURING AND HANDLING TEXTILES; PUMPS OTHER THAN MACHINE OR MOTOR PARTS, NAMELY, PNEUMATIC PUMPS AND HYDRAULIC PUMPS; ELECTRIC APPARATUS USED IN THE KITCHEN FOR CHOPPING, GRINDING, CRUSHING, MIXING AND CRUMBLING; WASHING MACHINES, NAMELY, LAUNDRY WASHING MACHINES, DISH WASHING MACHINES, DRY-CLEANING MACHINES; ELECTRICAL CLEANING MACHINES USED FOR FLOOR, CARPETS AND FLOOR COVERINGS, VACUUM CLEANERS AND THEIR PARTS (U.S. CLS. 13, 19, 21, 23, 31, 34 AND 35).

SN 79-085,810. DURFOM IZALASYON VE AMBALAJ SANAYI TICARET ANONIM SIRKETI, TURKEY, FILED 3-3-2010.

CLASS 16—PAPER GOODS AND PRINTED MATTER

FOR PAPER, CARDBOARD, PAPERBOARD AND PRODUCTS MADE OF THEM, EXCEPT USE FOR STATIONERY PURPOSES, NAMELY, BOXES OF PAPER OR CARDBOARD, CARDBOARD PACKAGING, AND PACKING PAPER; PACKAGING AND WRAPPING MATERIALS MADE OF PLASTIC MATERIALS, NAMELY, PLASTIC BAGS FOR PACKAGING, PLASTIC BUBBLE PACKS FOR WRAPPING OR PACKAGING; PRINTED MATTER, NAMELY, MAPS AND PRINTED GUIDE BOOKS FEATURING TRAVEL AND BOOKBINDING MATERIALS; PRINTED DOCUMENTS, NAMELY, MAPS AND PRINTED GUIDE BOOKS FEATURING TRAVEL;

OWNER OF INTERNATIONAL REGISTRATION 1047011 DATED 3-3-2010, EXPIRES 3-3-2020.

THE COLOR(S) RED IS/ARE CLAIMED AS A FEATURE OF THE MARK.

THE MARK CONSISTS OF THE WORDING "DURFOAM" IN LOWERCASE LETTERS AND IN RED.

PRINTED PUBLICATIONS, NAMELY, BOOKS AND MAGAZINES FEATURING COMPUTER INFORMATION; CALENDARS, POSTERS, PICTURES, NOTICES, NAMELY, ANNOUNCEMENT CARDS, CHARTS, STICKERS AND SEALING STAMPS; STATIONERY; OFFICE, EDUCATIONAL AND TEACHING MATERIALS EXCEPT FURNITURE AND APPARATUS, NAMELY, INSTRUCTION SHEETS AND MANUALS IN THE FIELD OF INSTRUCTIONAL MATH, TEACHING TILES, FRANKING MACHINES, ENVELOPE SEALING MACHINES, PUNCHES, AND STAPLERS; BRUSHES AND ROLLS FOR PAINTS (U.S. CLS. 2, 5, 22, 23, 29, 37, 38 AND 50).

CLASS 17—RUBBER GOODS

FOR RUBBER, GUTTA-PERCHA, GUM, ASBESTOS, MICA OR SEMI-MANUFACTURED SYNTHETIC PRODUCTS MADE OF RUBBER, GUTTA-PERCHA, GUM, ASBESTOS, MICA IN THE FORM OF POWDER, SHEET, STICK AND FOIL; PROCESSED AND SEMI-PROCESSED SYNTHETIC MATERIALS IN THE FORM OF PLATES, BARS, PIPES AND FLEXIBLE HOSES, AND GOODS IN THIS CLASS FOR ENERGY ISOLATION AND ABSORPTION PURPOSES, NAMELY, POLYURETHANE FOAM AND POLYETHYLENE FOAM; FLEXIBLE PIPES, FLEXIBLE HOSES, AND CONNECTING HOSES FOR VEHICLE RADIATORS AND FUEL INJECTORS HOSES, AND FLEXIBLE PIPES, ALL MADE OF GUM, PLASTIC OR RUBBER; TEXTILE HOSES FOR INDUSTRIAL APPLICATIONS AND HEAT AND SOUND INSULATION, FIRE HOSES, NONMETAL PIPE COVERS AND SLEEVES, INSULATING SLEEVES FOR HOSES, RADIATOR HOSES FOR VEHICLES MADE OF GUM, RUBBER AND PLASTIC (U.S. CLS. 1, 5, 12, 13, 35 AND 50).

RON FAIRBANKS, EXAMINING ATTORNEY

CLASS 9—ELECTRICAL AND SCIENTIFIC APPARATUS

FOR COMPUTER SOFTWARE FOR COMPUTER SYSTEM AND APPLICATION DEVELOPMENT, DEPLOYMENT AND MANAGEMENT; COMPUTER OPERATING SYSTEM SOFTWARE; COMPUTER UTILITY SOFTWARE; COMPUTER MIDDLEWARE BEING COMPUTER SOFTWARE FOR LINKING TOGETHER DISPARATE SOFTWARE SYSTEMS; COMPUTER APPLICATION SOFTWARE FOR MOBILE DEVICES INCLUDING MOBILE TELEPHONES, WIRELESS COMMUNICATION AND INFORMATION DEVICES, PERSONAL DIGITAL ASSISTANTS, PERSONAL ELECTRONIC ORGANIZERS, PORTABLE ELECTRONIC DEVICES, NET BOOKS, TABLETS, DIGITAL CAMERAS, PORTABLE NAVIGATION DEVICES AND SMARTPHONES, NAMELY, SOFTWARE FOR MAINTAINING, OPERATING AND MANAGING COMPUTER SYSTEMS; COMPUTER SOFTWARE FOR USE IN DEVELOPING, EXECUTING AND RUNNING OTHER SOFTWARE ON COMPUTERS, COMPUTER NETWORKS, GLOBAL COMMUNICATION NETWORKS, MOBILE COMPUTER NETWORKS AND MOBILE DEVICES INCLUDING MOBILE TELEPHONES, WIRELESS COMMUNICATION AND INFORMATION DEVICES, PERSONAL DIGITAL ASSISTANTS, PERSONAL ELECTRONIC ORGANIZERS, PORTABLE ELECTRONIC DEVICES, NETBOOKS, TABLETS, DIGITAL CAMERAS, PORTABLE NAVIGATION DEVICES AND SMARTPHONES; COMPUTER SOFTWARE DEVELOPMENT TOOLS; COMPUTER SOFTWARE FOR DATA TRANSMISSION, RECEPTION, MANAGEMENT, AND SYNCHRONIZATION OVER COMPUTER NETWORKS AND GLOBAL COMMUNICATION NETWORKS; COMPUTER SOFTWARE FOR COMMUNICATIONS MANAGEMENT, SYNCHRONIZATION AND EXCHANGE OF DATA BETWEEN MOBILE DEVICES AND DESKTOP COMPUTERS AND COMPUTER NETWORKS (U.S. CLS. 21, 23, 26, 36 AND 38).

CLASS 16—PAPER GOODS AND PRINTED MATTER

FOR PRINTED INSTRUCTION AND DEVELOPMENT MANUALS IN THE FIELD OF COMPUTER SOFTWARE; PRINTED DATA SHEETS IN THE FIELD OF COMPUTER SOFTWARE; BROCHURES IN THE FIELD OF COMPUTER SOFTWARE; BOOKS IN THE FIELD OF COMPUTER SOFTWARE; CARDBOARD PACKAGING; PLASTIC BAGS, ENVELOPES AND POUCHES FOR MERCHANDISE PACKAGING; PUBLICATIONS, NAMELY, MANUALS, BROCHURES, BOOKS, TEACHING MATERIALS, NEWSPAPERS, MAGAZINES, PRINTED PERIODICALS AND NEWSLETTERS IN THE FIELD OF COMPUTER SOFTWARE; PRINTED MATTER, NAMELY, MANUALS, BROCHURES, BOOKS, TEACHING MATERIALS, NEWSPAPERS, MAGAZINES, PRINTED PERIODICALS AND NEWSLETTERS ALL IN THE FIELD OF COMPUTER SOFTWARE FOR MOBILE DEVICES INCLUDING MOBILE TELEPHONES, WIRELESS COMMUNICATION AND INFORMATION DEVICES, PERSONAL DIGITAL ASSISTANTS, PERSONAL ELECTRONIC ORGANIZERS, PORTABLE ELECTRONIC DEVICES, NETBOOKS, TABLETS, DIGITAL CAMERAS, PORTABLE NAVIGATION DEVICES AND SMARTPHONES (U.S. CLS. 2, 5, 22, 23, 29, 37, 38 AND 50).

CLASS 41—EDUCATION AND ENTERTAINMENT

FOR TRAINING SERVICES, NAMELY, TRAINING IN THE USE OF COMPUTER HARDWARE AND COMPUTER SOFTWARE; EDUCATION SERVICES, NAMELY, PROVIDING TUTORIAL SESSIONS IN THE FIELD OF COMPUTER SOFTWARE, CLASSES, SEMINARS AND WORKSHOPS IN THE FIELD OF COMPUTER SOFTWARE AND LIVE AND ON-LINE CLASSES, SEMINARS AND WORKSHOPS ALL IN THE FIELD OF COMPUTER SOFTWARE; PROVISION OF INFORMATION ABOUT COMPUTER SOFTWARE TRAINING AND EDUCATION SPECIFICALLY IN THE FIELD OF COMPUTER SOFTWARE FOR USE ON MOBILE DEVICES INCLUDING MOBILE TELEPHONES, WIRELESS COMMUNICATION AND INFORMATION DEVICES, PERSONAL DIGITAL ASSISTANTS, PERSONAL ELECTRONIC ORGANIZERS, PORTABLE ELECTRONIC DEVICES, NETBOOKS, TA-

SN 79-085,859, LINARO LIMITED, UNITED KINGDOM, FILED 6-11-2010.

LINARO

THE MARK CONSISTS OF STANDARD CHARACTERS WITHOUT CLAIM TO ANY PARTICULAR FONT, STYLE, SIZE, OR COLOR.

PRIORITY DATE OF 5-20-2010 IS CLAIMED.

OWNER OF INTERNATIONAL REGISTRATION 1047055 DATED 6-11-2010, EXPIRES 6-11-2020.

THE WORDING "LINARO" HAS NO MEANING IN A FOREIGN LANGUAGE.

BLETS, DIGITAL CAMERAS, PORTABLE NAVIGATION DEVICES AND SMARTPHONES; ORGANIZING OF EDUCATIONAL CONFERENCES, EDUCATIONAL SYMPOSIUMS AND EDUCATIONAL MEETINGS IN THE FIELD OF COMPUTER SOFTWARE FOR USE ON MOBILE DEVICES INCLUDING MOBILE TELEPHONES, WIRELESS COMMUNICATION AND INFORMATION DEVICES, PERSONAL DIGITAL ASSISTANTS, PERSONAL ELECTRONIC ORGANIZERS, PORTABLE ELECTRONIC DEVICES, NETBOOKS, TABLETS, DIGITAL CAMERAS, PORTABLE NAVIGATION DEVICES AND SMARTPHONES (U.S. CLS. 100, 101 AND 107).

CLASS 42—SCIENTIFIC AND COMPUTER SERVICES

FOR RESEARCH, DEVELOPMENT, DESIGN CONSULTANCY, INSTALLATION AND MAINTENANCE RELATING TO COMPUTER SOFTWARE FOR A WIDE VARIETY OF MOBILE DEVICES INCLUDING MOBILE TELEPHONES, WIRELESS COMMUNICATION AND INFORMATION DEVICES, PERSONAL DIGITAL ASSISTANTS, PERSONAL ELECTRONIC ORGANIZERS, PORTABLE ELECTRONIC DEVICES, NETBOOKS, TABLETS, DIGITAL CAMERAS, PORTABLE NAVIGATION DEVICES AND SMARTPHONES; TECHNICAL SUPPORT SERVICES, NAMELY, TROUBLESHOOTING COMPUTER SOFTWARE PROBLEMS IN THE FIELDS OF COMPUTER SOFTWARE FOR MOBILE DEVICES INCLUDING MOBILE TELEPHONES, WIRELESS COMMUNICATION AND INFORMATION DEVICES, PERSONAL DIGITAL ASSISTANTS, PERSONAL ELECTRONIC ORGANIZERS, PORTABLE ELECTRONIC DEVICES, NETBOOKS, TABLETS, DIGITAL CAMERAS, PORTABLE NAVIGATION DEVICES AND SMARTPHONES; RESEARCH, DEVELOPMENT, DESIGN CONSULTANCY, INSTALLATION, MAINTENANCE AND TECHNICAL SUPPORT SERVICES FOR TROUBLESHOOTING COMPUTER SOFTWARE PROBLEMS IN THE FIELD OF COMPUTER SOFTWARE FOR THE DESIGN, DEVELOPMENT, MODELLING, SIMULATION, COMPILING, DEBUGGING, VERIFICATION, CONSTRUCTION AND INTERFACING OF ELECTRICAL AND ELECTRONIC EQUIPMENT (U.S. CLS. 100 AND 101).

MYRIAH HABEEB, EXAMINING ATTORNEY

SN 79-086,007. WÜNSCHE HANDELSGESELLSCHAFT INTERNATIONAL MBH & CO. KG, HAMBURG, FED REP GERMANY, FILED 5-27-2010.

LORADO

OWNER OF INTERNATIONAL REGISTRATION 0238500 DATED 12-15-1960, EXPIRES 12-15-2020.
OWNER OF U.S. REG. NO. 3,283,310.
THE WORDING "LORADO" HAS NO MEANING IN A FOREIGN LANGUAGE.

CLASS 29—MEATS AND PROCESSED FOODS

FOR CANNED OR BOTTLES VEGETABLES, NAMELY, OLIVES, BAMBOO SHOOTS, BEAN SPROUTS, MUSHROOMS, ASPARAGUS, RED CABBAGE, SAUERKRAUT, GHERKINS, CORNICHONS, MIXED PICKLES, MIXED VEGETABLES, GARLIC, CELERY, BEANS; CANNED OR BOTTLES TOMATOES, NAMELY, TOMATOES; PEELED, CHOPPED, MASHED, TOMATO PUREE; CANNED OR BOTTLES FRUITS, NAMELY, PEACHES, FRUIT COCKTAIL, MANDARIN-ORANGES, APRICOTS, PEARS, LYCHEES, MANGO, BANANAS, PAPAYA, GRAPEFRUIT, GUAVAS; TUNA, INCLUDING SUCH GOODS PACKAGED IN CONTAINERS, BOTTLES, OR PACKETS; DRIED, DEEP-FROZEN, CANNED OR PRESERVED FRUITS AND VEGETABLES; FRESH, DRIED, DEEP-FROZEN, CANNED OR PRESERVED FISH; FRESH, DRIED, DEEP-FROZEN, CANNED OR PRESERVED MEAT; FRESH, DRIED, DEEP-FROZEN, CANNED OR PRESERVED POULTRY; CONDENSED FRUIT AND VEGETABLE JUICES FOR COOKING; JUICE FOR COOKING, NAMELY, COCONUT MILK; SOUPS (U.S. CL. 46).

CLASS 30—STAPLE FOODS

FOR RICE, TEA, PASTA SAUCES, INCLUDING SUCH GOODS PACKAGED IN BOXES, BOTTLES, OR PACKETS; SOYA FLOUR FOR FOODSTUFFS (U.S. CL. 46).

CLASS 32—LIGHT BEVERAGES

FOR FRUIT JUICES, VEGETABLE JUICES (U.S. CLS. 45, 46 AND 48).

ANDREA HACK, EXAMINING ATTORNEY

SN 79-086,889. OCSLABO-ORALCARESCIENLABO S.A.G.L., CH-6900 LUGANO, SWITZERLAND, FILED 8-11-2010.

HEALTHY WHITE PRO

THE MARK CONSISTS OF STANDARD CHARACTERS WITHOUT CLAIM TO ANY PARTICULAR FONT, STYLE, SIZE, OR COLOR.

PRIORITY DATE OF 3-30-2010 IS CLAIMED.

OWNER OF INTERNATIONAL REGISTRATION 1049796 DATED 8-11-2010, EXPIRES 8-11-2020.

NO CLAIM IS MADE TO THE EXCLUSIVE RIGHT TO USE "WHITE" AS TO THE GOODS IN INTERNATIONAL CLASSES 3 AND 5, AND "HEALTHY" AS TO THE PHARMACEUTICAL PREPARATIONS IN INTERNATIONAL CLASS 5, APART FROM THE MARK AS SHOWN.

CLASS 3—COSMETICS AND CLEANING PREPARATIONS

FOR DENTRIFICES, NAMELY, TOOTHPASTE, TOOTH WHITENERS AND TOOTH BLEACHING PREPARATIONS (U.S. CLS. 1, 4, 6, 50, 51 AND 52).

CLASS 5—PHARMACEUTICALS

FOR PHARMACEUTICAL PREPARATIONS, NAMELY, MEDICATED TOOTHPASTE, MEDICATED TOOTH WHITENERS AND MEDICATED TOOTH BLEACHING PREPARATIONS (U.S. CLS. 6, 18, 44, 46, 51 AND 52).

JEFFERY COWARD, EXAMINING ATTORNEY

SN 79-086,935. ILOMBA IMAGES, F-75012 PARIS, FRANCE,
FILED 8-16-2010.

PAUL F. GAST, EXAMINING ATTORNEY



OWNER OF INTERNATIONAL REGISTRATION 1049953
DATED 8-16-2010, EXPIRES 8-16-2020.

NO CLAIM IS MADE TO THE EXCLUSIVE RIGHT TO
USE "CUISINE", APART FROM THE MARK AS SHOWN.

THE COLOR(S) PINK, ORANGE, WHITE AND RED IS/
ARE CLAIMED AS A FEATURE OF THE MARK.

THE MARK CONSISTS OF THE TERM "DANCING" IN
PINK AND "CUISINE" IN ORANGE WITH BOTH TERMS
HAVING A WHITE BORDER AND A DARK RED BORDER.

CLASS 16—PAPER GOODS AND PRINTED MATTER

FOR PAPER; CARDBOARD; SERIES OF BOOKS IN
THE FIELD OF COOKING RECIPES; BOOKBINDING
MATERIAL; PHOTOGRAPHS; STATIONERY; ADHES-
IVES FOR STATIONERY OR HOUSEHOLD PURPOSES;
PAINTBRUSHES; TYPEWRITERS; SERIES OF INSTRUC-
TIONAL OR TEACHING BOOKS IN THE FIELD OF
COOKING RECIPES; PRINTING TYPE; PRINTING
BLOCKS (U.S. CLS. 2, 5, 22, 23, 29, 37, 38 AND 50).

CLASS 21—HOUSEWARES AND GLASS

FOR BASTING BRUSH; BASTING SYRINGE; BROWN-
ING TRAY; BUTCHER BLOCK; CAULDRON; CHEESE
GRATER; CHOPPING BOARD; COLANDER; COCONUT
GRATER; COOKIE CUTTER; CHOP STICKS; CUTTING
BOARD; DOUBLE BOILER; NON ELECTRICAL DOUGH
BLENDER; DRUM SIEVE; NON ELECTRICAL EGG
BEATER; FRYING PAN; GARLIC PRESS; GRATER;
COOKING UTENSILS, NAMELY, GRILLS; SERVING
LADLE; LEMON REAMER; LEMON SQUEEZER; MAT-
ED COLANDER POT; MELON BALLER; MIXING
BOWL; MIXING SPOON; MUFFIN TIN; PASTRY BAG;
PASTRY BRUSH; PEPPER MILL; PIE PAN; PIZZA
PLATE; POTATO RICER; ROLLING PIN; SALT SHA-
KER; SCOOP; POT AND PAN SCRAPER; SIEVE; SKIM-
MER; SPATULA; COOKING STRAINER; SERVING
TONGS; NON ELECTRICAL WAFFLE IRON; COMBS
AND CLEANING SPONGES; FOOD BRUSHES; BROOM;
DUSTPAN; MOP; MOP BUCKET; STEEL WOOL; UN-
WORKED OR SEMI-WORKED GLASS NOT USED IN
BUILDINGS; BEVERAGE GLASSWARE; PORCELAIN
AND EARTHENWARE CUPS, POTS AND BOWLS (U.S.
CLS. 2, 13, 23, 29, 30, 33, 40 AND 50).

CLASS 38—COMMUNICATION

FOR ELECTRONIC BULLETIN BOARD SERVICES;
TELECOMMUNICATION SERVICES, NAMELY, ELEC-
TRONIC BULLETIN BOARD SERVICES; TELEVISION
BROADCASTING (U.S. CLS. 100, 101 AND 104).

CLASS 41—EDUCATION AND ENTERTAIN- MENT

FOR PROVIDING OF FOOD PREPARATION TRAIN-
ING; ENTERTAINMENT SHOWS IN THE FIELD OF
COOKING VIDEO SHOW BROADCASTED ON LINE, ON
TV OR ON ANY DEVICE ENABLING TO WATCH THE
SHOW, ORGANIZING AND CONDUCTING SPORTING
AND CULTURAL ACTIVITIES, NAMELY, DANCE
CLASSES AND FINE CUISINE CLASSES; VIDEOTAPE
FILM PRODUCTION, TELEVISION ENTERTAINMENT
SHOWS; VIDEOTAPING; FILM PRODUCTION; VIDEOTAPE
EDITING; PRODUCTION OF RADIO AND TELE-
VISION PROGRAMS; ORGANIZATION OF
COMPETITIONS GATHERING ABOUT FOOD MAKING
AND DANCE PERFORMANCE; FILM PRODUCTION
(U.S. CLS. 100, 101 AND 107).

SN 79-087,534. INES STEINHAEUER, FED REP GERMANY,
AND JURGEN ZIMMERMANN, FED REP GERMANY,
FILED 8-9-2010.

JIVALA

THE MARK CONSISTS OF STANDARD CHARACTERS
WITHOUT CLAIM TO ANY PARTICULAR FONT, STYLE,
SIZE, OR COLOR.

PRIORITY DATE OF 2-10-2010 IS CLAIMED.

OWNER OF INTERNATIONAL REGISTRATION 1051627
DATED 8-9-2010, EXPIRES 8-9-2020.

THE WORDING "JIVALA" HAS NO MEANING IN A
FOREIGN LANGUAGE.

CLASS 3—COSMETICS AND CLEANING PRE- PARATIONS

FOR ARTICLES FOR BODY AND BEAUTY CARE,
NAMELY, COSMETICS; BATH AND SHOWER OILS,
COSMETIC PREPARATIONS FOR BATHS, SCENTED
OILS, SKIN MOISTURIZER, MOISTURIZING LOTIONS
AND CREAMS, SKIN CLEANSING PREPARATIONS
AND MOISTURIZING PREPARATIONS FOR THE SKIN;
COSMETICS, IN PARTICULAR CREAMS, MILKS,
LOTIONS, GELS AND POWDERS FOR FACE, BODY AND
HANDS, NON-MEDICATED PREPARATIONS FOR USE
IN THE BATH, PREPARATIONS AND SUBSTANCES
FOR THE CARE AND APPEARANCE OF THE SKIN,
BODY, FACE, EYES, HAIR, TEETH AND NAILS; COS-
METIC PREPARATIONS FOR THE CARE, TREATMENT
AND CONDITIONING OF COSMETIC TISSUE (U.S. CLS.
1, 4, 6, 50, 51 AND 52).

CLASS 9—ELECTRICAL AND SCIENTIFIC APPARATUS

FOR MUSIC RECORDINGS, MUSIC VIDEO RECORD-
INGS; PRERECORDED DATA CARRIERS OF ALL KIND
CONTAINING MUSIC AND MUSIC VIDEO RECORD-
INGS; DOWNLOADABLE DIGITAL MUSIC VIDEO RE-
CORDINGS AND MUSIC RECORDINGS (U.S. CLS. 21,
23, 26, 36 AND 38).

CLASS 10—MEDICAL APPARATUS

FOR MEDICAL EQUIPMENT, MACHINES AND AP-
PARATUS FOR NON-INVASIVE HYGIENIC AND
BEAUTY CARE SKIN TREATMENT PROCEDURES, IN
PARTICULAR FOR ULTRASOUND TREATMENT,
LIGHT THERAPY, NAMELY, A BLACK-LIGHT BLUE
LAMP UNIT FOR USE IN IDENTIFICATION OF A
VARIETY OF SKIN CONDITIONS, LIGHT-PULSE COS-
METIC THERAPY, BODY CONTOURING WITH CAVI-
TATION, COLD LASER TREATMENT,
TRANSCUTANEOUS ELECTRIC NERVE STIMULA-
TION, BIOLOGICAL CYBERNETICS, SKIN TIGHTEN-
ING, FAT REDUCTION, PAIN THERAPY TREATMENT,
NAMELY, ELECTRICAL NERVE AND MUSCLE STIMU-
LATORS, MICRO-CURRENT TREATMENT, NAMELY,
ELECTRONIC STIMULATORS FOR DAMAGED TISSUE
AND CELLS (U.S. CLS. 26, 39 AND 44).

CLASS 20—FURNITURE AND ARTICLES NOT OTHERWISE CLASSIFIED

FOR FURNITURE; SHOP FURNITURE, IN PARTICU-
LAR FOR BEAUTY SALONS (U.S. CLS. 2, 13, 22, 25, 32
AND 50).

CLASS 44—MEDICAL, BEAUTY AND AGRICULTURAL SERVICES

FOR HYGIENIC AND BEAUTY CARE; NUTRITION CONSULTANCY; PROVIDING INFORMATION AND CONSULTANCY WITH REGARD TO HEALTH; SERVICES IN THE FIELD OF HYGIENIC CARE AND BEAUTY CARE, NAMELY, HYGIENIC AND BEAUTY CARE SERVICES; BEAUTY SALONS; DIETETIC CONSULTANCY; SKIN-CARE SALONS; COSMETIC CONSULTANCY, NAMELY, BEAUTY CONSULTATION SERVICES IN THE SELECTION AND USE OF COSMETICS, FRAGRANCES, BEAUTY AIDS, PERSONAL CARE PRODUCTS, AND BATH, BODY AND BEAUTY PRODUCTS; COSMETIC SERVICES, NAMELY, COSMETIC BODY CARE SERVICES IN THE NATURE OF BODY WRAPS; MEDICAL CONSULTANCY SERVICES; MEDICAL SERVICES; MEDICAL ASSISTANCE; BEAUTY CARE AND HAIR CARE SERVICES, NAMELY, HAIR STYLING; BEAUTY SALONS; RENTAL OF MACHINES AND APPARATUS FOR HYGIENIC AND BEAUTY CARE, NAMELY, FOR USE IN BEAUTY SALONS OR BARBERS' SHOPS; AROMATHERAPY SERVICES; SERVICES IN THE FIELD OF APPARATIVE COSMETICS, NAMELY, INTENSE PULSE LIGHT SKIN ENHANCEMENT PROCEDURES (U.S. CLS. 100 AND 101).

CLASS 45—PERSONAL AND LEGAL SERVICES

FOR LICENSING OF INDUSTRIAL PROPERTY RIGHTS, NAMELY, INTELLECTUAL PROPERTY (U.S. CLS. 100 AND 101).

PAM WILLIS, EXAMINING ATTORNEY

SN 79-087,717. SICPA HOLDING SA, CH-1008 PRILLY, SWITZERLAND, FILED 9-13-2010.

SICPADIGITALIS

THE MARK CONSISTS OF STANDARD CHARACTERS WITHOUT CLAIM TO ANY PARTICULAR FONT, STYLE, SIZE, OR COLOR.

PRIORITY DATE OF 6-10-2010 IS CLAIMED.

OWNER OF INTERNATIONAL REGISTRATION 1052142 DATED 9-13-2010, EXPIRES 9-13-2020.

OWNER OF U.S. REG. NOS. 1,565,337, 2,375,720 AND OTHERS.

CLASS 2—PAINTS

FOR SECURITY PRINTING INKS; PAINTS FOR ANY KIND OF GRAPHIC PRINTING; SICCATIVES FOR USE AS A DRYING AGENT FOR COATINGS AND INKS; MORDANTS FOR USE IN THE PRINTING INDUSTRY; PREPARATIONS OF SECURITY MARKINGS OR VISIBLE OR INVISIBLE MARKINGS AS WELL AS FACINGS AND COMPOSITIONS, ALL THE ABOVE MADE OF OR BASED ON PRINTING INKS, COPYING INKS, PRINTING PASTES, PAINTS, RAW NATURAL RESINS AND/OR METAL FOILS (U.S. CLS. 6, 11 AND 16).

CLASS 16—PAPER GOODS AND PRINTED MATTER

FOR PAPER, CARDBOARD; PRINTED MATTER, NAMELY, GOODS MADE OF PAPER AND CARDBOARD, NAMELY, BANK-NOTES, PRINTED TICKETS, ADHESIVE AND/OR PAPER LABELS, PENNANTS MADE OF PAPER, FINANCIAL, FIDUCIARY AND FISCAL DOCUMENTS, NAMELY, STOCK CERTIFICATES, MARKING STAMPS, IDENTIFICATION CARDS, SECURITY CARDS, CREDIT CARDS AND DEBIT CARDS WITHOUT MAGNETIC CODING, AND BUSINESS FORMS; PRINTING TYPE, PRINTING BLOCKS (U.S. CLS. 2, 5, 22, 23, 29, 37, 38 AND 50).

CLASS 40—MATERIAL TREATMENT

FOR TREATMENT OF MATERIALS, NAMELY, PRINTING, DIGITAL PHOTO PRINTING, DIGITAL ON-DEMAND PRINTING SERVICES OF MARKINGS, AFFIXING AND EMBEDDING PRODUCT AUTHENTICATION SECURITY DEVICES AND MATERIALS IN A WIDE VARIETY OF PRODUCTS AND DOCUMENTS TO PROTECT AGAINST COUNTERFEITING, TAMPERING, AND DIVERSION, AND TO ENSURE THE INTEGRITY OF GENUINE PRODUCTS AND DOCUMENTS; CONSULTATION SERVICES IN THE FIELD OF PRINTING (U.S. CLS. 100, 103 AND 106).

CLASS 45—PERSONAL AND LEGAL SERVICES

FOR SECURITY CONSULTANCY, INCLUDING PROFESSIONAL CONSULTING ON SECURITY ELEMENTS THAT PROVIDES AUTHENTICATION AND IDENTIFICATION OF BANK NOTES, SECURITY, FIDUCIARY AND LEGITIMATION DOCUMENTS; LICENSING OF INTELLECTUAL PROPERTY (U.S. CLS. 100 AND 101).

KATHERINE M. DUBRAY, EXAMINING ATTORNEY

SN 79-087,836. NISSHA PRINTING CO., LTD., JAPAN, FILED 3-29-2010.

N i s s h a I n - M e t a l

THE MARK CONSISTS OF STANDARD CHARACTERS WITHOUT CLAIM TO ANY PARTICULAR FONT, STYLE, SIZE, OR COLOR.

PRIORITY DATE OF 9-29-2009 IS CLAIMED.

OWNER OF INTERNATIONAL REGISTRATION 1052446 DATED 3-29-2010, EXPIRES 3-29-2020.

OWNER OF U.S. REG. NO. 2,791,631.

THE WORDING "NISSHA" HAS NO MEANING IN A FOREIGN LANGUAGE.

CLASS 7—MACHINERY

FOR TRANSFER MACHINES AND APPARATUS, NAMELY, MACHINES FOR USE IN TRANSFERRING PRE-PRINTED PATTERNS TO ARTICLE SURFACES; LAMINATING MACHINES FOR INDUSTRIAL USE, NAMELY, FILM LAMINATING MACHINES AND APPARATUS FOR USE IN METAL DECORATION; LAMINATING MACHINES FOR INDUSTRIAL USE, NAMELY, FILM LAMINATING MACHINES AND APPARATUS FOR USE IN METAL DECORATION BY OVERLAYING PLASTIC LAMINATION FILMS ONTO METAL SURFACES; LAMINATING MACHINES FOR INDUSTRIAL USE, NAMELY, FILM LAMINATING MACHINES AND APPARATUS FOR USE IN METAL DECORATION BY OVERLAYING TRANSFER LAYERS ONTO METAL SURFACES BY USE OF PLASTIC TRANSFER FILMS; CONVEYORS IN THE NATURE OF FILM FEEDING MACHINES AND APPARATUS FOR USE IN METAL DECORATION; CONVEYORS IN THE NATURE OF FILM FEEDING MACHINES AND APPARATUS FOR USE IN METAL DECORATION BY OVERLAYING PLASTIC LAMINATION FILMS ONTO METAL SURFACES; CONVEYORS IN THE NATURE OF FILM FEEDING MACHINES AND APPARATUS FOR USE IN METAL DECORATION BY OVERLAYING TRANSFER LAYERS ONTO METAL SURFACES BY USE OF PLASTIC TRANSFER FILMS; PLASTIC FILM LAMINATING MACHINES AND APPARATUS, NAMELY, PLASTIC FILM LAMINATING MACHINES FOR INDUSTRIAL USE; CONVEYORS IN THE NATURE OF PLASTIC FILM FEEDING MACHINES AND APPARATUS; INJECTION PLASTIC MOLDING MACHINES THAT INTEGRALLY MOLD PLASTIC AND METAL AND ALSO PERFORM TRANSFER PROCESS ON METAL SURFACES; INJECTION PLASTIC MOLDING MACHINES THAT INTEGRALLY MOLD PLASTIC AND METAL AND ALSO PERFORM LAMINATION PROCESS ON METAL SURFACES; MACHINE PARTS, NAMELY, MOLDS FOR USE IN THE MANUFACTURE OF PLASTICS; MECHANICAL PRESSES FOR METAL WORKING; PRESS DIES FOR METAL FORMING; MACHINE PARTS, NAMELY, MOLDS FOR USE IN THE MANUFACTURE OF METAL

DECORATION; MACHINE PARTS, NAMELY, MOLDS FOR USE IN THE MANUFACTURE OF METAL DECORATION BY OVERLAYING PLASTIC LAMINATION FILMS ONTO METAL SURFACES; MACHINE PARTS, NAMELY, MOLDS FOR USE IN THE MANUFACTURE OF METAL DECORATION BY OVERLAYING TRANSFER LAYERS ONTO METAL SURFACES BY USE OF PLASTIC TRANSFER FILMS (U.S. CLS. 13, 19, 21, 23, 31, 34 AND 35).

CLASS 17—RUBBER GOODS

FOR PLASTIC TRANSFER FILMS FOR COMMERCIAL AND INDUSTRIAL USE; PLASTIC FILMS FOR COMMERCIAL AND INDUSTRIAL USE, NAMELY, PLASTIC TRANSFER FILMS FOR USE IN METAL DECORATION; PLASTIC FILMS FOR COMMERCIAL AND INDUSTRIAL USE, NAMELY, PLASTIC TRANSFER FILMS FOR USE IN METAL DECORATION BY OVERLAYING TRANSFER LAYERS ONTO METAL SURFACES BY USE OF PLASTIC TRANSFER FILMS; PLASTIC FILMS FOR COMMERCIAL AND INDUSTRIAL USE, NAMELY, PLASTIC LAMINATION FILMS; PLASTIC FILMS FOR COMMERCIAL AND INDUSTRIAL USE, NAMELY, PLASTIC LAMINATION FILMS FOR USE IN METAL DECORATION; PLASTIC FILMS FOR COMMERCIAL AND INDUSTRIAL USE, NAMELY, PLASTIC LAMINATION FILMS FOR USE IN METAL DECORATION BY OVERLAYING PLASTIC LAMINATION FILMS ONTO METAL SURFACES (U.S. CLS. 1, 5, 12, 13, 35 AND 50).

JAY BESCH, EXAMINING ATTORNEY

SN 79-088,177. DAVID AVIV, ISRAEL, AND HELEN DUKAT, ISRAEL, FILED 10-5-2010.



OWNER OF INTERNATIONAL REGISTRATION 1053425 DATED 10-5-2010, EXPIRES 10-5-2020.

THE MARK CONSISTS OF A STYLIZED IMAGE OF A TREE.

CLASS 14—JEWELRY

FOR JEWELRY, NECKLACES, EARRINGS, BRACELETS, PINS BEING JEWELRY AND RINGS MADE OF SILVER, GOLD, OTHER METALS, PLATED METALS AND OTHER MATERIALS (U.S. CLS. 2, 27, 28 AND 50).

CLASS 25—CLOTHING

FOR TANK TOPS, T-SHIRTS, PANTS, JEANS, LINGERIE, HATS, COATS, SWEATERS, SHIRTS, DRESSES, SKIRTS, SHOES FOR WOMEN AND MEN, BOOTS, SANDALS, FLIP FLOPS (U.S. CLS. 22 AND 39).

COLLEEN DOMBROW, EXAMINING ATTORNEY

SN 79-088,439. SWISS CAPS RECHTE UND LIZENZEN AG, SWITZERLAND, FILED 9-14-2010.



OWNER OF INTERNATIONAL REGISTRATION 1054209 DATED 9-14-2010, EXPIRES 9-14-2020.

THE MARK CONSISTS OF THE WORDING "AENOVA" IN STYLIZED FONT WITH A CRESCENT SYMBOL TO THE LEFT OF THE WORDING.

THE WORDING "AENOVA" HAS NO MEANING IN A FOREIGN LANGUAGE.

CLASS 39—TRANSPORTATION AND STORAGE

FOR FILLING OF BLISTERS, SACHETS, JARS, BOTTLES AND TUBES WITH PHARMACEUTICAL PRODUCTS, DIETETIC PRODUCTS FOR MEDICAL USE, FOOD SUPPLEMENTS AND NUTRITIONAL SUPPLEMENTS, VITAMIN PREPARATIONS AND COSMETICS TO THE ORDER AND SPECIFICATION OF OTHERS; PACKAGING OF PHARMACEUTICAL PRODUCTS, DIETETIC PRODUCTS FOR MEDICAL USE, FOOD SUPPLEMENTS AND NUTRITIONAL SUPPLEMENTS, VITAMIN PREPARATIONS, COSMETICS TO THE ORDER AND SPECIFICATION OF OTHERS; PACKAGING OF MEDICAL PRODUCTS TO THE ORDER AND SPECIFICATION OF OTHERS (U.S. CLS. 100 AND 105).

CLASS 40—MATERIAL TREATMENT

FOR CUSTOM MANUFACTURE TO THE ORDER AND SPECIFICATION OF OTHERS OF MEDICINES, PHARMACEUTICAL PRODUCTS, DIETETIC PRODUCTS FOR MEDICAL USE, FOOD SUPPLEMENTS FOR MEDICAL USE, VITAMIN PREPARATIONS AND COSMETICS AND MEDICAL PRODUCTS (U.S. CLS. 100, 103 AND 106).

CLASS 42—SCIENTIFIC AND COMPUTER SERVICES

FOR RESEARCH AND DEVELOPMENT IN THE FIELD OF PHARMACEUTICAL PRODUCTS NUTRITIONAL SUPPLEMENTS AND ADDITIVES, VITAMIN PREPARATIONS, DIETETIC PRODUCTS FOR MEDICAL USE, COSMETICS, MEDICAL PRODUCTS; SCIENTIFIC AND TECHNOLOGICAL SERVICES, NAMELY, SCIENTIFIC RESEARCH, ANALYSIS, TESTING IN THE FIELD OF PHARMACEUTICAL PRODUCTS, NUTRITIONAL SUPPLEMENTS, VITAMIN PREPARATIONS, DIETETIC PRODUCTS FOR MEDICAL USE, COSMETICS AND MEDICAL PRODUCTS; QUALITY CONTROL FOR OTHERS AND CHEMICAL ANALYSIS OF PHARMACEUTICAL PRODUCTS, NUTRITIONAL SUPPLEMENTS AND ADDITIVES, VITAMIN PREPARATIONS, DIETETIC PRODUCTS FOR MEDICAL USE, COSMETICS, MEDICAL PRODUCTS, EXCEPT FOR THE ABOVE-MENTIONED SERVICES IN THE FIELDS OF GYNECOLOGY AND ARTIFICIAL INSEMINATION (U.S. CLS. 100 AND 101).

CLASS 45—PERSONAL AND LEGAL SERVICES

FOR LICENSING OF INTELLECTUAL PROPERTY RIGHTS IN THE FIELD OF PHARMACEUTICAL PRODUCTS, FOOD SUPPLEMENTS AND NUTRITIONAL SUPPLEMENTS, VITAMIN PREPARATIONS, DIETETIC PRODUCTS FOR MEDICAL USE, COSMETICS, MEDICAL PRODUCTS (U.S. CLS. 100 AND 101).

WILLIAM ROSSMAN, EXAMINING ATTORNEY

SN 79-088,621. THE CROWN IN RIGHT OF THE STATE OF VICTORIA, REPRESENTED BY AND ACTING THROUGH THE DEPARTMENT, THE DEPARTMENT OF EDUCATION AND EARLY CHILDHOOD DEVELOPMENT, AUSTRALIA, FILED 7-14-2010.



PRIORITY DATE OF 1-15-2010 IS CLAIMED.
OWNER OF INTERNATIONAL REGISTRATION 1054648
DATED 7-14-2010, EXPIRES 7-14-2020.

THE MARK CONSISTS OF A LOWER CASE "E" ADJACENT TO THE NUMBER "5" IN SUPERSCRIPIT FORMAT. ALL OF THE AFOREMENTIONED APPEARS ON A SHADED CIRCLE SURROUNDED BY A LARGER CIRCLE DIVIDED INTO THREE SECTIONS, WITH THE TOP TWO SECTIONS BEING EQUAL AND THE BOTTOM SECTION BEING SMALLER. THE DIVIDED CIRCLE FORMS THE TOP OF A STYLIZED ELECTRICAL PLUG WITH A CABLE EXTENDING FROM THE BOTTOM AND TO THE LEFT OF THE PLUG AND WITH THREE SMALL, SHADED RECTANGLES APPEARING TO THE RIGHT OF THE PLUG, FORMING A STYLIZED ELECTRICAL OUTLET.

CLASS 9—ELECTRICAL AND SCIENTIFIC APPARATUS

FOR DOWNLOADABLE PUBLICATIONS IN THE NATURE OF NEWSLETTERS IN THE FIELD OF TEACHING ELEMENTARY EDUCATION AND CREATING TEACHER LESSON PLANS, PROVIDED OVER THE INTERNET, ONLINE OR THROUGH ANY COMPUTER OR COMMUNICATIONS NETWORK; COMPUTERS AND COMPUTER SOFTWARE FOR EDUCATIONAL OR TRAINING PURPOSES, NAMELY, CREATING TEACHER LESSON PLANS AND FOR INSTRUCTION IN THE TEACHING OF ELEMENTARY EDUCATION; PRE-RECORDED COMPACT DISCS AND CD-ROMS FEATURING EDUCATIONAL CURRICULUM IN THE FIELD OF TEACHING ELEMENTARY EDUCATION AND CREATING TEACHER LESSON PLANS; OTHER AUDIO AND AUDIOVISUAL, INTERACTIVE AND MULTIMEDIA RECORDINGS IN THE NATURE OF DVDS FEATURING MATTER IN THE FIELD OF TEACHING ELEMENTARY EDUCATION AND CREATING TEACHER LESSON PLANS AND USER MANUALS AND GUIDES SOLD AS A UNIT THEREWITH; TEACHING APPARATUS AND INSTRUMENTS, NAMELY, EDUCATIONAL DVDS FEATURING TEACHING OF ELEMENTARY EDUCATION (U.S. CLS. 21, 23, 26, 36 AND 38).

CLASS 16—PAPER GOODS AND PRINTED MATTER

FOR PRINTED MATTER AND PUBLICATIONS, NAMELY, BOOKS, MANUALS, JOURNALS, NEWSLETTERS, AND BOOKLETS, ALL IN THE FIELD OF TEACHING ELEMENTARY EDUCATION; STATIONERY; STICKERS; POSTERS; INSTRUCTIONAL AND TEACHING MATERIALS IN THE FIELD OF TEACHING ELEMENTARY EDUCATION (U.S. CLS. 2, 5, 22, 23, 29, 37, 38 AND 50).

CLASS 41—EDUCATION AND ENTERTAINMENT

FOR EDUCATIONAL AND INSTRUCTIONAL SERVICES IN THE NATURE OF CLASSES, SEMINARS, COURSES AND WORKSHOPS IN THE FIELD OF TEACHING ELEMENTARY EDUCATION AND CREATING TEACHER LESSON PLANS; TRAINING SERVICES IN THIS CLASS, NAMELY, TEACHER TRAINING SERVICES IN THE FIELD OF TEACHING ELEMENTARY EDUCATION; INFORMATION SERVICES RELATING TO EDUCATIONAL SERVICES; VOCATIONAL GUIDANCE SERVICES; EDUCATION CONSULTANCY SERVICES IN THE FIELD OF TEACHING ELEMENTARY EDUCATION; ARRANGING AND CONDUCTING EDUCATIONAL COMPETITIONS, EXHIBITIONS, WORKSHOPS, SEMINARS AND CONFERENCES IN THE FIELD OF TEACHING ELEMENTARY EDUCATION; PUBLICATION OF EDUCATIONAL MATERIALS AND TEXTS IN ELECTRONIC AND NON-ELECTRONIC FORMAT ACCESSIBLE VIA AN ONLINE FACILITY AND ANY COMPUTER OR COMMUNICATIONS NETWORK; PRODUCTION, PUBLICATION AND DISSEMINATION OF EDUCATIONAL AUDIOVISUAL PROGRAMS IN THE FIELD OF TEACHING ELEMENTARY EDUCATION (U.S. CLS. 100, 101 AND 107).

KAREN SEVERSON, EXAMINING ATTORNEY

SN 79-088,622. THE CROWN IN RIGHT OF THE STATE OF VICTORIA, REPRESENTED BY AND ACTING THROUGH THE DEPARTMENT, THE DEPARTMENT OF EDUCATION AND EARLY CHILDHOOD DEVELOPMENT, AUSTRALIA, FILED 7-14-2010.



PRIORITY DATE OF 1-15-2010 IS CLAIMED.
OWNER OF INTERNATIONAL REGISTRATION 1054649
DATED 7-14-2010, EXPIRES 7-14-2020.

THE MARK CONSISTS OF A LOWER CASE "E" ADJACENT TO THE NUMBER "5" IN SUPERSCRIPIT FORMAT. ALL OF THE AFOREMENTIONED APPEARS ON A SHADED HOT AIR BALLOON WITH THE BASKET PORTION OF THE HOT AIR BALLOON FORMED BY TWO SQUARES CONNECTED AT AN ANGLE.

CLASS 9—ELECTRICAL AND SCIENTIFIC APPARATUS

FOR DOWNLOADABLE PUBLICATIONS IN THE NATURE OF NEWSLETTERS IN THE FIELD OF TEACHING ELEMENTARY EDUCATION AND CREATING TEACHER LESSON PLANS, PROVIDED OVER THE INTERNET, ONLINE OR THROUGH ANY COMPUTER OR COMMUNICATIONS NETWORK; COMPUTERS AND COMPUTER SOFTWARE FOR EDUCATIONAL OR TRAINING PURPOSES, NAMELY, CREATING TEACHER LESSONS PLANS AND FOR INSTRUCTION IN THE TEACHING OF ELEMENTARY EDUCATION; PRE-RECORDED COMPACT DISCS AND CD-ROMS FEATURING EDUCATIONAL CURRICULUM IN THE FIELD OF TEACHING ELEMENTARY EDUCATION AND CREATING TEACHER LESSON PLANS; OTHER AUDIO AND AUDIOVISUAL, INTERACTIVE AND MULTIMEDIA RECORDINGS IN THE NATURE OF DVDS FEATURING MATTER IN THE FIELD OF TEACHING ELEMENTARY EDUCATION AND CREATING TEACHER LESSON PLANS AND USER MANUALS AND GUIDES SOLD AS A UNIT THEREWITH; TEACHING APPARATUS AND INSTRUMENTS, NAMELY, EDUCATIONAL DVDS FEATURING TEACHING OF ELEMENTARY EDUCATION (U.S. CLS. 21, 23, 26, 36 AND 38).

CLASS 16—PAPER GOODS AND PRINTED MATTER

FOR PRINTED MATTER AND PUBLICATIONS, NAMELY, BOOKS, MANUALS, JOURNALS, NEWSLETTERS, AND BOOKLETS, ALL IN THE FIELD OF TEACHING ELEMENTARY EDUCATION; STATIONERY; STICKERS; POSTERS; INSTRUCTIONAL AND TEACHING MATERIALS IN THE FIELD OF TEACHING ELEMENTARY EDUCATION (U.S. CLS. 2, 5, 22, 23, 29, 37, 38 AND 50).

CLASS 41—EDUCATION AND ENTERTAINMENT

FOR EDUCATIONAL AND INSTRUCTIONAL SERVICES IN THE NATURE OF CLASSES, SEMINARS, COURSES AND WORKSHOPS IN THE FIELD OF TEACHING ELEMENTARY EDUCATION AND CREATING TEACHER LESSON PLANS; TRAINING SERVICES IN THIS CLASS, NAMELY, TEACHER TRAINING SERVICES IN THE FIELD OF TEACHING ELEMENTARY EDUCATION; INFORMATION SERVICES RELATING TO EDUCATIONAL SERVICES; VOCATIONAL GUIDANCE SERVICES; EDUCATION CONSULTANCY SERVICES IN THE FIELD OF TEACHING ELEMENTARY EDUCATION; ARRANGING AND CONDUCTING EDUCATIONAL COMPETITIONS, EXHIBITIONS, WORKSHOPS, SEMINARS AND CONFERENCES IN THE FIELD OF TEACHING ELEMENTARY EDUCATION; PUBLICATION OF EDUCATIONAL MATERIALS AND TEXTS IN ELECTRONIC AND NON-ELECTRONIC FORMAT ACCESSIBLE VIA AN ONLINE FACILITY AND ANY COMPUTER OR COMMUNICATIONS NETWORK; PRODUCTION, PUBLICATION AND DISSEMINATION OF EDUCATIONAL AUDIOVISUAL PROGRAMS IN THE FIELD OF TEACHING ELEMENTARY EDUCATION (U.S. CLS. 100, 101 AND 107).

KAREN SEVERSON, EXAMINING ATTORNEY

SN 79-088,763. MINISTERO DELLE POLITICHE AGRICOLE, ALIMENTARI E FORESTALI - DIPARTIMENTO DELLE POLITICHE COMPETITIVE DEL MONDO RURALE E DELLA QUALITA' - DIREZIONE GENERALE PER LO SVILUPPO AGROALIMENTARE, LA QUALITA' E LA TUTELA DEL CONSUMATORE, ITALY, FILED 4-16-2010.

FAGIOLO DI LAMON DELLA VALLATA BELLUNESE

THE MARK CONSISTS OF STANDARD CHARACTERS WITHOUT CLAIM TO ANY PARTICULAR FONT, STYLE, SIZE, OR COLOR.

PRIORITY DATE OF 2-8-2010 IS CLAIMED.

OWNER OF INTERNATIONAL REGISTRATION 1055039 DATED 4-16-2010, EXPIRES 4-16-2020.

NO CLAIM IS MADE TO THE EXCLUSIVE RIGHT TO USE "FAGIOLO", APART FROM THE MARK AS SHOWN.

THE ENGLISH TRANSLATION OF "FAGIOLO DI LAMON DELLA VALLATA BELLUNESE" IN THE MARK IS "BEAN FROM LAMON IN THE BELLUNO VALLEY".

THE CERTIFICATION MARK, AS INTENDED TO BE USED BY PERSONS AUTHORIZED BY THE CERTIFIER, IS INTENDED TO CERTIFY THAT THE GOODS PROVIDED ORIGINATE IN THE AREA INCLUDING THE FELTRINO, BELLUNESE AND VAL BELLUNA MOUNTAIN COMMUNITIES, ALL LOCATED IN THE PROVINCE OF BELLUNO IN ITALY, AND THAT THE PREPARATION, PRODUCTION, AND/OR PROCESSING OF THE GOODS TAKE PLACE IN THE AREA IDENTIFIED IN THE STANDARD OF RECORD.

CLASS 29—MEATS AND PROCESSED FOODS

FOR PRESERVED BEANS (U.S. CL. 46).

CLASS 31—NATURAL AGRICULTURAL PRODUCTS

FOR UNPROCESSED BEANS (U.S. CLS. 1 AND 46).
SUE LAWRENCE, EXAMINING ATTORNEY

SN 79-088,868. BULLARD GMBH, FED REP GERMANY, FILED 8-11-2010.



PRIORITY DATE OF 2-22-2010 IS CLAIMED.

OWNER OF INTERNATIONAL REGISTRATION 1055346 DATED 8-11-2010, EXPIRES 8-11-2020.

THE MARK CONSISTS OF THE STYLIZED WORDING "MAGMA" WITH AN OVER-ARCHING BAND DESIGN TO THE RIGHT OF THE WORDING.

CLASS 9—ELECTRICAL AND SCIENTIFIC APPARATUS

FOR PROTECTIVE CLOTHING ITEMS FOR ACCIDENT AND FIRE PROTECTION, NAMELY, SAFETY HELMETS, USED FOR FIRE-FIGHTING, SEARCH AND RESCUE, EMERGENCY RESPONSE, AND WORK SAFETY, PROTECTIVE VISORS AND MASKS FOR SAFETY HELMETS, AND ATTACHMENT MECHANISMS, NAMELY, RECEPTORS FOR CONNECTING ACCESSORIES TO SAFETY HELMETS (U.S. CLS. 21, 23, 26 AND 38).

CLASS 11—ENVIRONMENTAL CONTROL APPARATUS

FOR LIGHTING DEVICES, NAMELY, LAMPS FOR FIRE-FIGHTING SAFETY HELMETS AND WORK SAFETY HELMETS (U.S. CLS. 13, 21, 23, 31 AND 34).

TIMOTHY FINNEGAN, EXAMINING ATTORNEY

SN 79-089,082. VOCAM PTY LTD AS TRUSTEE FOR THE ROSE CLASS UNIT TRUST, CAMBERWELL, AUSTRALIA, FILED 5-14-2010.

SN 79-089,065. BENTA BERRY, FRANCE, FILED 9-16-2010.

BENTA BERRY

THE MARK CONSISTS OF STANDARD CHARACTERS WITHOUT CLAIM TO ANY PARTICULAR FONT, STYLE, SIZE, OR COLOR.

PRIORITY DATE OF 4-19-2010 IS CLAIMED.

OWNER OF INTERNATIONAL REGISTRATION 1055946 DATED 9-16-2010, EXPIRES 9-16-2020.

NO CLAIM IS MADE TO THE EXCLUSIVE RIGHT TO USE "BERRY", APART FROM THE MARK AS SHOWN.

THE ENGLISH TRANSLATION OF THE WORD "BENTA" IN THE MARK IS ALTITUDE FARM IN THE PYRENEES OFFERING A CATERING SERVICE.



OWNER OF INTERNATIONAL REGISTRATION 1055996 DATED 5-14-2010, EXPIRES 5-14-2020.

THE COLOR(S) BLUE, BLACK AND WHITE IS/ARE CLAIMED AS A FEATURE OF THE MARK.

THE MARK CONSISTS OF THE WORDING "SAFETY-TV" WITH THE "SAFETY" IN BLUE AND THE WORD "TV" IN WHITE SURROUNDED BY BLACK. THE HYPHEN IS BLUE ON THE LEFT HALF AND WHITE ON THE RIGHT HALF.

CLASS 3—COSMETICS AND CLEANING PREPARATIONS

FOR SOAPS, PERFUMERY, ESSENTIAL OILS, COSMETICS; PERFUMES, TOILET WATER, EAU-DE-COLOGNE, PERSONAL DEODORANTS; CLEANSING MILK FOR TOILET PURPOSES; COSMETIC PREPARATIONS; NON-MEDICATED SKIN CARE PREPARATIONS, NAMELY, CREAMS, GELS, MILKS, LOTIONS, MASKS, POMADES AND POWDERS; COSMETIC ANTI-WRINKLE PREPARATIONS; COSMETIC PREPARATIONS FOR LIP CARE; COSMETIC SUNSCREEN PREPARATIONS, COSMETIC SUN-TANNING PREPARATIONS, COSMETIC AFTERSUN PREPARATIONS; COSMETIC PREPARATIONS FOR SLIMMING PURPOSES; DEPILATORY PREPARATIONS; COSMETIC PREPARATIONS FOR BATHS; MAKE-UP AND MAKE-UP REMOVING PREPARATIONS; PLANT EXTRACTS FOR COSMETIC USE; NON-MEDICATED PREPARATIONS FOR HAIR AND SCALP CARE; PREPARATIONS FOR SHAVING AND AFTERSHAVE PREPARATIONS; MOIST TOWELETTES AND TISSUES IMPREGNATED WITH COSMETIC LOTIONS; COTTON WOOL FOR COSMETIC PURPOSES; COTTON STICKS FOR COSMETIC PURPOSES; MAKE-UP REMOVAL PADS; INCENSE; SCENTED WATER; ROOM FRAGRANCING PREPARATIONS; SACHETS FOR PERFUMING LINEN; SHOWER GELS, BATH SALTS NOT FOR MEDICAL USE; CREAMS, MILKS, LOTIONS, GELS AND POWDERS FOR THE FACE, BODY AND HANDS; SHAMPOOS; NON-MEDICATED GELS, MOUSSES, BALMS AND AEROSOLS FOR HAIRDRESSING AND HAIR CARE; HAIR SPRAY; HAIR DYES AND HAIR BLEACHING PREPARATIONS; HAIR WAVING AND SETTING PREPARATIONS; HAIR LOTIONS, PERFUMED MILKS AND BEAUTY CREAMS FOR BODY CARE; ESSENTIAL OILS FOR PERSONAL USE, SCENTED GELS, MILKS, LOTIONS, CREAMS, EMULSIONS FOR THE FACE AND BODY, DEODORANTS FOR PERSONAL USE (U.S. CLS. 1, 4, 6, 50, 51 AND 52).

CLASS 44—MEDICAL, BEAUTY AND AGRICULTURAL SERVICES

FOR HYGIENIC AND BEAUTY CARE; MESSAGES; BEAUTY SALONS; SAUNA SERVICES; SPA SERVICES FEATURING COSMETIC FACE AND BEAUTY CARE; HEALTH SPA SERVICES FOR HEALTH AND WELLNESS OF THE BODY AND SPIRIT, NAMELY, PROVIDING MASSAGE, FACIAL AND BODY TREATMENT SERVICES, COSMETIC BODY CARE SERVICES; BALNEOTHERAPY, PHYSIOTHERAPY AND AROMATHERAPY SERVICES; PROVIDING TURKISH BATH FACILITIES (U.S. CLS. 100 AND 101).

KATHY DE JONGE, EXAMINING ATTORNEY

CLASS 9—ELECTRICAL AND SCIENTIFIC APPARATUS

FOR APPARATUS FOR RECORDING, TRANSMISSION OR REPRODUCTION OF IMAGES OR SOUND, NAMELY, BLANK VIDEOTAPES, BLANK DVDS, BLANK CD-ROMS, BLANK COMPACT DISCS, BLANK MAGNETIC TAPES AND BLANK AUDIO CASSETTES; COMPUTER PROGRAMS FOR THE PURPOSE OF PROVIDING INSTRUCTIONS ON HEALTH AND SAFETY IN THE WORKPLACE; DATA, NAMELY, DATA RELATING TO THE FIELD OF HEALTH AND SAFETY IN THE WORKPLACE RECORDED ELECTRONICALLY FROM THE INTERNET ON CDS, DVDS, DOWNLOADABLE DATA FILES, COMPUTER MEDIA; DATA, NAMELY, DATA RELATING TO THE FIELD OF HEALTH AND SAFETY IN THE WORKPLACE RECORDED IN MACHINE-READABLE FORM FROM THE INTERNET ON CDS, DVDS, DOWNLOADABLE DATA FILES, COMPUTER MEDIA; DOWNLOADABLE DIGITAL MUSIC FROM THE INTERNET, DOWNLOADABLE DIGITAL MUSIC PROVIDED FROM MP3 WEBSITES ON THE INTERNET; WEEKLY PUBLICATIONS, NAMELY, NEWSLETTERS IN RELATION TO HEALTH AND SAFETY IN THE WORKPLACE DOWNLOADED IN ELECTRONIC FORMAT FROM THE INTERNET; DATA AND CONTENT DELIVERED AS DOWNLOADABLE ELECTRONIC PUBLICATIONS, NAMELY, NEWSLETTERS IN RELATION TO HEALTH AND SAFETY IN THE WORKPLACE OVER THE INTERNET AND LOCAL INTRANETS AND/OR LOCAL AREA NETWORK (LAN); COMPUTER SOFTWARE FOR EDUCATIONAL AND TRAINING PURPOSES FEATURING INSTRUCTION IN HEALTH AND SAFETY IN THE WORKPLACE; ONLINE IDENTITY VALIDATION SYSTEM COMPRISING COMPUTER HARDWARE AND SOFTWARE FOR AUTHENTICATION AND VALIDATION OF AN INDIVIDUAL'S CREDENTIALS (U.S. CLS. 21, 23, 26, 36 AND 38).

CLASS 41—EDUCATION AND ENTERTAINMENT

FOR EDUCATION SERVICES, NAMELY, PROVIDING CLASSES IN THE FIELDS OF HEALTH AND SAFETY IN THE WORKPLACE; PROVIDING TRAINING IN THE FIELDS OF HEALTH AND SAFETY IN THE WORKPLACE; EDUCATION SERVICES, NAMELY, CLASSES AND TRAINING SERVICES RELATING TO HEALTH AND SAFETY IN THE WORKPLACE; ARRANGING AND CONDUCTING SEMINARS AND COURSES IN THE FIELDS OF HEALTH AND SAFETY IN THE WORKPLACE; THE PROVISION OF EDUCATION CLASSES, TRAINING AND SEMINAR SERVICES IN THIS CLASS OVER THE INTERNET AND LOCAL INTRANET AND/OR LOCAL AREA NETWORK (LAN) IN THE FIELDS OF HEALTH AND SAFETY IN THE WORKPLACE; PROVISION OF NON-DOWNLOADABLE ELECTRONIC PUBLICATIONS, NAMELY, NEWSLETTERS IN RELATION TO HEALTH AND SAFETY IN THE WORKPLACE; ELECTRONIC PUBLISHING SERVICES, NAMELY, PUBLICATION OF TEXT AND GRAPHIC WORKS OF OTHERS ON CD, DVD AND ONLINE FEATURING HEALTH AND SAFETY IN THE WORKPLACE; EDUCATIONAL CLASSES AND TRAINING SERVICES IN THE FIELDS OF OCCUPATIONAL HEALTH AND SAFETY SERVICES; PRODUCTION OF ONLINE VIDEO SEGMENTS FOR STREAMING ON THE INTERNET (U.S. CLS. 100, 101 AND 107).

CLASS 42—SCIENTIFIC AND COMPUTER SERVICES

FOR INFORMATION SERVICES RELATING TO DESIGN OF SOFTWARE FOR OCCUPATIONAL HEALTH AND SAFETY; CONSULTATION IN THE FIELD OF ERGONOMICS, NAMELY, DESIGNING WORKPLACE FACILITIES AND EQUIPMENT TO OPTIMIZE OCCUPATIONAL HEALTH AND SAFETY; HOSTING OF WEBSITES AND WEBSITE DESIGN SERVICES FOR THE PROVISION OF INFORMATION ON OCCUPATIONAL HEALTH AND SAFETY (U.S. CLS. 100 AND 101).

CLASS 45—PERSONAL AND LEGAL SERVICES

FOR LEGAL ADVICE RELATING TO OCCUPATIONAL HEALTH AND SAFETY (U.S. CLS. 100 AND 101).
 RON FAIRBANKS, EXAMINING ATTORNEY

SN 79-089,198. SUOMEN JÄÄKIEKKOLIITTO - FINLANDS ISHOCKEYFÖRBUND RY, FI-00610 HELSINKI, FINLAND, FILED 9-16-2010.



OWNER OF INTERNATIONAL REGISTRATION 1056254 DATED 9-16-2010, EXPIRES 9-16-2020.
 THE COLOR(S) BLUE AND BLACK IS/ARE CLAIMED AS A FEATURE OF THE MARK.
 THE MARK CONSISTS OF A BLUE CURVED BANNER OUTLINED IN BLACK ON A BLUE CHEVRON OR "V" SHAPE OUTLINED IN BLACK.

CLASS 16—PAPER GOODS AND PRINTED MATTER

FOR PAPER, CARDBOARD, PAPER BAGS, BOND PAPER, PAPER GIFT WRAPPING PAPER, CARDBOARD BOXES, POSTERS, POSTCARDS, TRADING CARDS, TEMPORARY TATTOOS; PRINTED MATTER, NAMELY, BOOKS, MAGAZINES, NEWSPAPERS, INSTRUCTIONAL AND TEACHING MATERIAL, MANUALS, NEWSLETTERS AND NEWS SHEETS, ALL RELATED TO ICE HOCKEY AND ENTERTAINMENT; ALBUMS FOR PHOTOGRAPHS, COINS AND STAMPS, DIARIES, CALENDARS AND STICKERS; PHOTOGRAPHS; STATIONERY; ADHESIVES FOR STATIONERY OR HOUSEHOLD PURPOSES; ARTISTS' MATERIALS; PAINT BRUSHES; TYPEWRITERS AND OFFICE REQUISITES, NAMELY, STAPLERS, PAPER CLIPS, PUNCHES, WRITING AND DRAWING IMPLEMENTS, NAMELY, INK PENS, PENCILS AND MARKERS; INSTRUCTIONAL AND TEACHING MATERIAL IN THE FIELD OF HOCKEY, SPORTS AND SPORTS MANAGEMENT; PLASTIC MATERIALS FOR PACKAGING, NAMELY, PLASTIC BAGS FOR PACKAGING, PLASTIC BUBBLE PACKS FOR WRAPPING OR PACKAGING (U.S. CLS. 2, 5, 22, 23, 29, 37, 38 AND 50).

CLASS 25—CLOTHING

FOR CLOTHING, NAMELY, SHIRTS, T-SHIRTS, TROUSERS, SHORTS, JACKETS; TRAINING CLOTHES AND SPORTSWEAR, NAMELY, TRAINING JACKETS, TRAINING SHOES, TRACK JACKETS, SWEATSHIRTS, HOODED SWEATSHIRTS, TANK TOPS, T-SHIRTS, TROUSERS, SHORTS, SWEATPANTS, TRACKSUITS, WINDPANTS AND WIND JACKETS; SOCKS, GLOVES, SCARVES; FOOTWEAR; HEADGEAR, NAMELY, CAPS, FLAT CAPS, HATS, SWEAT BANDS (U.S. CLS. 22 AND 39).

CLASS 41—EDUCATION AND ENTERTAINMENT

FOR EDUCATION, NAMELY, PROVIDING CLASSES, SEMINARS, WORKSHOPS AND TRAINING CAMPS IN THE FIELD OF HOCKEY, SPORTS AND SPORT MANAGEMENT; PROVIDING OF TRAINING IN THE FIELD OF HOCKEY, SPORTS AND SPORTS MANAGEMENT; ENTERTAINMENT, NAMELY, ENTERTAINMENT IN THE NATURE OF VISUAL AND AUDIO PERFORMANCES, NAMELY, MUSICAL BAND, ROCK GROUP, SKATING AND ICE HOCKEY; SPORTING AND CULTURAL ACTIVITIES, NAMELY, ENTERTAINMENT IN THE NATURE OF ICE HOCKEY GAMES (U.S. CLS. 100, 101 AND 107).
 KATHY DE JONGE, EXAMINING ATTORNEY

SN 79-089,213. WE-EF LEUCHTEN GMBH & CO. KG, BISPINGEN, FED REP GERMANY, FILED 10-1-2010.

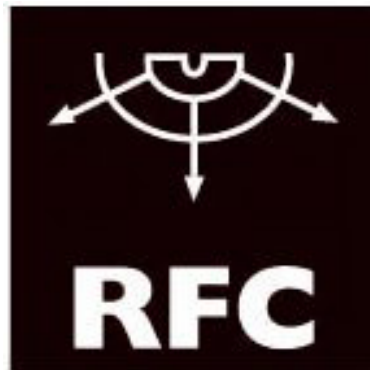

PRIORITY DATE OF 5-10-2010 IS CLAIMED.
 OWNER OF INTERNATIONAL REGISTRATION 1056301 DATED 10-1-2010, EXPIRES 10-1-2020.

THE MARK CONSISTS OF THE DESIGN OF A STYLIZED LIGHT SOURCE, A SPACED APART SEMICIRCLE BELOW THE STYLIZED LIGHT SOURCE, AND THREE STYLIZED LIGHT RAYS IN THE FORM OF ARROWS BEGINNING AT THE STYLIZED LIGHT SOURCE AND PASSING THROUGH THE SEMICIRCLE. THE LETTERS "RFC" APPEAR BELOW THE DESIGN.

CLASS 9—ELECTRICAL AND SCIENTIFIC APPARATUS

FOR LIGHT DIMMERS (U.S. CLS. 21, 23, 26, 36 AND 38).

CLASS 11—ENVIRONMENTAL CONTROL APPARATUS

FOR LAMPS, INCLUDING LEDS; LIGHTS; PARTS FOR LIGHTS, IN PARTICULAR TRANSPARENT LIGHT COVERS (U.S. CLS. 13, 21, 23, 31 AND 34).

CLASS 35—ADVERTISING AND BUSINESS

FOR PROFESSIONAL BUSINESS CONSULTANCY IN THE FIELD OF LIGHTING ENGINEERING, AND IN THE FIELD OF THE TECHNICAL AND DECORATIVE LIGHTING OF OBJECTS (U.S. CLS. 100, 101 AND 102).
CAROLYN CATALDO, EXAMINING ATTORNEY

CLASS 38—COMMUNICATION

FOR TELECOMMUNICATIONS, NAMELY, ELECTRONIC DATA TRANSMISSION; AUDIOVISUAL BROADCASTING; RADIO BROADCASTING, TELEVISION BROADCASTING AND RADIO BROADCASTING; ALL TYPES OF COMMUNICATION SERVICES, NAMELY, NEWS AGENCY SERVICES FOR ELECTRONIC TRANSMISSION, ELECTRONIC TRANSMISSION OF INFORMATION; COMMUNICATION BY RADIO, TELEPHONE, TELEGRAM AND COMPUTER; SENDING AND TRANSMISSION OF TELEGRAMS AND MESSAGES; ALL SERVICES INTENDED TO INFORM THE GENERAL PUBLIC AND MEDIA PROFESSIONAL, NAMELY, TRANSMISSION OF COMPILED DATA AND INFORMATION ON MEDIA ACTIVITY AND AUDIENCES VIA COMPUTER COMMUNICATION OR ANY OTHER MEANS (U.S. CLS. 100, 101 AND 104).

CLASS 42—SCIENTIFIC AND COMPUTER SERVICES

FOR COMPUTER PROGRAMMING SERVICES IN THE FIELD OF MEASURING MEDIA AUDIENCES (U.S. CLS. 100 AND 101).
DOMINIC FATHY, EXAMINING ATTORNEY

SN 79-089,301. MEDIAMETRIE, F-92300 LEVALLOIS PERRET, FRANCE, FILED 10-8-2010.

SN 79-089,303. ORIGINAL1 GMBH, FRANKFURT/MAIN, FED REP GERMANY, FILED 8-30-2010.

MyETV

THE MARK CONSISTS OF STANDARD CHARACTERS WITHOUT CLAIM TO ANY PARTICULAR FONT, STYLE, SIZE, OR COLOR.

PRIORITY DATE OF 4-13-2010 IS CLAIMED.
OWNER OF INTERNATIONAL REGISTRATION 1056551 DATED 10-8-2010, EXPIRES 10-8-2020.

CLASS 35—ADVERTISING AND BUSINESS

FOR PROVIDING STATISTICAL INFORMATION OR COMPILATION OF STATISTICS FOR BUSINESS OR COMMERCIAL PURPOSES; INFORMATION AND INQUIRY SERVICES IN THE FIELD OF BUSINESS, NAMELY, CARRYING OUT PUBLIC OPINION POLLS AND SURVEYS AMONG THE GENERAL PUBLIC ON AUDIO VISUAL AND OTHER MEDIA FORMS; ADVERTISING SERVICES; BUSINESS MANAGEMENT ASSISTANCE AND ADVICE FOR INDUSTRIAL OR COMMERCIAL COMPANIES; COMPILATION AND PROCESSING, PARTICULARLY COMPUTER-BASED, STATISTICAL WORK AND ANALYSES, PARTICULARLY RELATING TO MEDIA AUDIENCE AND OTHER DATA, NAMELY, GATHERING, COMPILATION AND SYSTEMIZATION OF DATA INTO DATABANKS; PUBLIC OPINION POLLS; STATISTICAL BUSINESS DATA ANALYSES, BUSINESS RESEARCH AND FEASIBILITY STUDIES FOR BUSINESS PURPOSES; MARKETING ANALYSIS, RESEARCH AND STUDIES; ARRANGING NEWSPAPER SUBSCRIPTIONS FOR OTHERS (U.S. CLS. 100, 101 AND 102).



OWNER OF INTERNATIONAL REGISTRATION 1056554 DATED 8-30-2010, EXPIRES 8-30-2020.

THE MARK CONSISTS OF A BLACK CIRCLE FORMED BY A THICK BLACK LINE WITH A BLACK DOT IN THE CENTER OF THE CIRCLE AND HAVING A DIAMETER OF BETWEEN ONE-THIRD AND ONE-HALF OF THE DIAMETER OF THE CIRCLE AND THE DOT BEING CONNECTED BY A SOLID TRAPEZOID AT THE SIX O'CLOCK POSITION (THE MARK RESEMBLES A KEY-HOLE).

CLASS 9—ELECTRICAL AND SCIENTIFIC APPARATUS

FOR ELECTRONIC COMPONENTS, NAMELY, RADIO FREQUENCY IDENTIFICATION DEVICES AND RELATED EQUIPMENT, NAMELY, READERS, MARKERS, MARKER ETCHERS AND PROXIMITY MARKS FOR TRACKING AND TRACING OF GOODS AND BRANDS AND FOR ACCESS SECURITY, IDENTIFICATION, AUTHENTICATION, INVENTORY OR PHYSICAL STATE CONTROL; COMPUTER SOFTWARE FOR USE IN TRACKING OBJECTS, AUTHENTICATION, MANAGING INVENTORIES, OPTIMIZING DELIVERY RUNS, FINANCIAL TRANSACTIONS AND PRODUCTION PROCESSES; DOWNLOADABLE DATABASES FEATURING INFORMATION FOR TRACKING OBJECTS, PRODUCT AUTHENTICATION, MANAGING INVENTORIES, OPTIMIZING DELIVERY RUNS, FINANCIAL TRANSACTIONS AND PRODUCTION PROCESSES; SOFTWARE FOR RFID READERS AND FOR WRITING PROGRAMS FOR SYSTEMS OF IDENTIFICATION AND AUTHENTICATION BY OPTICAL AND/OR RADIO FREQUENCY SYSTEMS; TRANSPONDERS FOR USE IN OPTICAL IDENTIFICATION AND AUTHENTICATION SYSTEMS; COMPUTER PROGRAMS FOR DECRYPTION AND ENCRYPTION; COMPUTER NETWORK INTERFACE DEVICES FOR SETTING UP NETWORKS OF INTERFACES BETWEEN READERS AND TRANSMISSION LINE DATA OR COMPUTERS; PRE-RECORDED MAGNETIC DATA CARRIERS, NAMELY, MAGNETIC TAPES, MAGNETIC DISKS, MAGNETIC WAFERS, MAGNETIC CARDS AND SMART CARDS CONTAINING PRODUCT AUTHENTICATION INFORMATION, TRACKING INFORMATION, SUPPLY CHAIN INFORMATION, PRODUCTION RUN INFORMATION, PRODUCTION PROCESS INFORMATION, DELIVERY RUN INFORMATION, AND INFORMATION RELATING TO FINANCIAL TRANSACTIONS (U.S. CLS. 21, 23, 26, 36 AND 38).

CLASS 16—PAPER GOODS AND PRINTED MATTER

FOR PRINTED MATERIALS, NAMELY, CATALOGS, MANUALS, USER GUIDES, AND OPERATING INSTRUCTION SHEETS, FEATURING INFORMATION ON SOFTWARE AND DATA PROCESSING PROGRAMS (U.S. CLS. 2, 5, 22, 23, 29, 37, 38 AND 50).

CLASS 35—ADVERTISING AND BUSINESS

FOR COMPILATION AND SYSTEMATIZATION OF INFORMATION RELATING TO THE TRACKING AND MANAGING INVENTORIES OF GOODS AND BRANDS AND PRODUCT AUTHENTICATION IN DATA BANKS ACCESSIBLE ON THE INTERNET; BUSINESS CONSULTATION SERVICES IN THE FIELDS OF SUPPLY CHAIN ANALYSIS AND COUNTERFEIT DETECTION; BUSINESS CONSULTING SERVICES IN THE FIELD OF TRACKING AND MANAGING INVENTORIES OF GOODS AND BRANDS OF OTHERS; PROVIDING ONLINE DATABASES IN THE FIELD OF TRACKING OBJECTS AND MANAGING INVENTORIES FOR COMMERCIAL PURPOSES; INTERNET SERVICES, NAMELY, PROVIDING DATA AND INFORMATION ON THE INTERNET REGARDING THE TRACKING AND MANAGING INVENTORIES OF GOODS AND BRANDS AND OUTSOURCING THE SALES AND MARKETING OF COMPUTER PROGRAMS AND SOFTWARE; TRACKING OF MANUFACTURED ARTICLES USING IDENTIFICATION DEVICES AND EQUIPMENT FOR COMMERCIAL PURPOSES; INFORMATION CONCERNING TRACKING OF MANUFACTURED ARTICLES USING IDENTIFICATION DEVICES AND EQUIPMENT FOR COMMERCIAL PURPOSES (U.S. CLS. 100, 101 AND 102).

CLASS 38—COMMUNICATION

FOR TELECOMMUNICATIONS, NAMELY, COMMUNICATIONS BY RADIO FREQUENCIES; ELECTRONIC TRANSMISSION OF INFORMATION TAKEN FROM DATA BANKS, COMPUTER-AIDED MESSAGE TRANSMISSION, AND COMMUNICATIONS BY COMPUTER TERMINALS; PROVISION OF INTERACTIVE TELEPHONE AND ELECTRONIC MAIL COMMUNICATIONS SERVICES PROVIDED ONLINE OR VIA THE INTERNET RELATING TO THE TRACKING, AUTHENTICATION, AND MANAGING INVENTORIES OF GOODS AND BRANDS, AND MAINTENANCE, RENTAL, UPDATING, DESIGN, AND OUTSOURCING OF COMPUTER PROGRAMS AND SOFTWARE; COMPUTER TRANSMISSION OF ONLINE BASED SERVICES ACCESSED VIA A NETWORK REFERENCE, NAMELY, A URI, VISUAL CODE, NAMELY, BARCODES, TAG, NAMELY, RFID, TERMINAL, NAMELY, PC OR MOBILE DEVICE, OR ANY COMBINATION THEREOF (U.S. CLS. 100, 101 AND 104).

CLASS 39—TRANSPORTATION AND STORAGE

FOR TRANSPORT, PACKAGING ARTICLES FOR TRANSPORTATION, AND STORAGE OF MANUFACTURED ARTICLES OF OTHERS USING IDENTIFICATION DEVICES AND EQUIPMENT; INFORMATION CONCERNING TRANSPORT, PACKAGING ARTICLES FOR TRANSPORTATION, DELIVERY, AND STORAGE OF MANUFACTURED ARTICLES OF OTHERS USING IDENTIFICATION DEVICES AND EQUIPMENT (U.S. CLS. 100 AND 105).

CLASS 40—MATERIAL TREATMENT

FOR CUSTOM MANUFACTURE OF DATA AND STANDARD BARCODE IDENTIFIERS FOR THE IDENTIFICATION OF GOODS, SERVICES AND PLACES (U.S. CLS. 100, 103 AND 106).

CLASS 42—SCIENTIFIC AND COMPUTER SERVICES

FOR DEVELOPMENT AND MAINTENANCE OF DATABASES; DEVELOPMENT, UPDATING AND MAINTENANCE OF COMPUTER SOFTWARE, ESPECIALLY FOR OBJECT IDENTIFICATION, AUTHENTICATION, TRACING, PROTECTION AND TRACKING, INVENTORY MANAGEMENT AND DELIVERY RUN OPTIMIZATION; PROVIDING COMPUTER SOFTWARE PROGRAMMING FOR DATABASES AND ALL SYSTEMS FOR OPTICAL AND/OR RADIO FREQUENCY IDENTIFICATION; HOSTING WEB SITES, IN PARTICULAR OF DATA AND INFORMATION IN COMPUTER DATA BASES ACCESSIBLE ON THE INTERNET, INCLUDING DATA AND INFORMATION RELATING TO THE TRACKING, AUTHENTICATION AND MANAGING INVENTORIES OF GOODS AND BRANDS, MAINTENANCE, RENTAL, UPDATING, DESIGN AND OUTSOURCING OF COMPUTER PROGRAMS AND SOFTWARE; ENGINEERING SERVICES IN THE NATURE OF PROVIDING TECHNICAL PROJECT STUDIES, STUDY AND EXPERTISE IN THE FIELD OF RADIO FREQUENCY IDENTIFICATION TECHNOLOGY; DESIGN OF COMPUTER SYSTEMS; ELECTRONIC DATABASE STORAGE SERVICES; DESIGN AND DEVELOPMENT OF NUMBERING STRUCTURES, OF DATA AND STANDARD BARCODE IDENTIFIERS FOR THE IDENTIFICATION OF GOODS, SERVICES AND PLACES; TECHNICAL CONSULTING SERVICES RELATED TO THE FOREGOING (U.S. CLS. 100 AND 101).

CLASS 45—PERSONAL AND LEGAL SERVICES

FOR DETECTION OF COUNTERFEITING, IN PARTICULAR GLOBAL SERVICES FOR BRAND NAMES IN THE NATURE OF CONSULTATION IN THE FIELDS OF PRODUCT AND DOCUMENT AUTHENTICATION AND TRACKING, AND BRAND MONITORING AND PROTECTION, TO PROTECT AGAINST COUNTERFEITING, TAMPERING, AND DIVERSION, AND TO ENSURE THE INTEGRITY OF GENUINE PRODUCTS AND DOCUMENTS; PROTECTION OF INDUSTRIAL PROPERTY RIGHTS, IN PARTICULAR GLOBAL SERVICES FOR TRADEMARKS IN THE NATURE OF LEGAL SERVICES, NAMELY, INTELLECTUAL PROPERTY CONSULTING SERVICES IN THE FIELD OF INVENTION, IDENTIFICATION, STRATEGY, ANALYTICS, AND INVENTION (U.S. CLS. 100 AND 101).

KIMBERLY PERRY, EXAMINING ATTORNEY

SN 79-089,455. PC LOCS PTY LTD, AUSTRALIA, FILED 6-17-2010.



PRIORITY DATE OF 3-22-2010 IS CLAIMED.
OWNER OF INTERNATIONAL REGISTRATION 1056897 DATED 6-17-2010, EXPIRES 6-17-2020.

THE MARK CONSISTS OF THE WORDING "LOCK N CHARGE" AND DESIGN. THE DESIGN CONSISTS OF A SQUARE WITH CURVED ANGLES. WITHIN THE SQUARE IS THE IMAGE OF A PADLOCK THAT IS FORMED BY A SERIES OF DOTS. TO THE RIGHT OF THE DESIGN IS THE WORDING "LOCK N CHARGE". A LIGHTNING BOLT APPEARS BETWEEN THE TERM "LOCK" AND THE LETTER "N" AND ANOTHER LIGHTNING BOLT APPEARS BETWEEN THE LETTER "N" AND THE TERM "CHARGE".

CLASS 9—ELECTRICAL AND SCIENTIFIC APPARATUS

FOR POWER BOARDS, ELECTRICAL TIMERS AND ELECTRIC SOCKETS FOR CHARGING COMPUTER RELATED EQUIPMENT INCLUDING LAPTOPS AND DESKTOP COMPUTERS, ELECTRICAL POWER BOARDS; ELECTRICAL AND VOLTAGE SURGE PROTECTORS; POWER ADAPTORS AND APPARATUS FOR PROTECTING COMPUTERS FROM POWER SUPPLY FAULTS AND RELATED APPARATUS; BATTERY CHARGERS FOR LAPTOP COMPUTERS AND PORTABLE ELECTRONIC DEVICES; ZIPPER LOCKABLE AND SEALED CARRY BAGS ADAPTED TO CARRY COMPUTER EQUIPMENT INCLUDING LAPTOPS AND PORTABLE ELECTRONIC DEVICES, NAMELY, LAPTOP COMPUTERS, NOTEBOOK COMPUTERS, TABLET COMPUTERS, PERSONAL DIGITAL ASSISTANTS, ELECTRONIC PERSONAL ORGANIZERS, HANDHELD COMPUTERS, PORTABLE MUSIC PLAYERS AND MP3 PLAYERS, MOBILE PHONES (U.S. CLS. 21, 23, 26, 36 AND 38).

CLASS 16—PAPER GOODS AND PRINTED MATTER

FOR ADVERTISING MATERIALS IN PAPER FORM, NAMELY, PRODUCT AND SERVICE CATALOGS AND GUIDES IN THE FIELD OF PORTABLE ELECTRONICS; PRINTED MATERIAL, NAMELY, ADVERTISING LEAFLETS AND BROCHURES FOR ADVERTISING PURPOSES; CARDBOARD PACKAGING, PAPER FOR WRAPPING AND PACKAGING, BOXES AND BAGS OF SYNTHETIC MATERIALS FOR WRAPPING AND PACKAGING, PLASTIC BAGS FOR PACKAGING (U.S. CLS. 2, 5, 22, 23, 29, 37, 38 AND 50).

CLASS 20—FURNITURE AND ARTICLES NOT OTHERWISE CLASSIFIED

FOR LOCKABLE FIXED AND PORTABLE STORAGE CABINET COMBINATIONS MADE OF METAL, TIMBER AND PLASTIC INCLUDING RESIN AND REPLACEMENT PARTS THEREOF FOR THE SECURE STORAGE OF COMPUTER HARDWARE AND PORTABLE ELECTRICAL DEVICES; REINFORCED AND LOCKABLE STORAGE CABINETS FOR STORAGE OF COMPUTER HARDWARE AND RELATED COMPUTER EQUIPMENT; LOCKABLE AND REINFORCED CARTS AND REPLACEMENT PARTS THEREOF FOR SECURE TRANSPORT OF COMPUTER HARDWARE AND RELATED COMPUTER EQUIPMENT (U.S. CLS. 2, 13, 22, 25, 32 AND 50).

CLASS 35—ADVERTISING AND BUSINESS

FOR WHOLESALE AND RETAIL STORE SERVICES; DIRECT MAIL ADVERTISING SERVICES AND ONLINE RETAILING SERVICES; ADVERTISING SERVICES; RETAIL AND ONLINE MARKETING AND SALES PROMOTIONS, NAMELY, SALES PROMOTIONS AT POINT OF SALE OR PURCHASE, SALES PROMOTIONS BY MEANS OF DISPLAY, PRESENTATION AND DEMONSTRATION ON COMMUNICATION MEDIA FOR RETAIL PURPOSES; DIRECT MAIL MARKETING (U.S. CLS. 100, 101 AND 102).

MARLENE BELL, EXAMINING ATTORNEY

SN 79-089,464. VOOZ CLUB CO., LTD., REPUBLIC OF KOREA, FILED 7-27-2010.

CANIMAL

OWNER OF INTERNATIONAL REGISTRATION 1056912 DATED 7-27-2010, EXPIRES 7-27-2020.

CLASS 16—PAPER GOODS AND PRINTED MATTER

FOR HEAT TRANSFER PAPER; TOILET PAPER; NOTE BOOKS; POCKET NOTE BOOKS; SKETCH BOOKS; BALLPOINT PENS; FELT MARKING PENS; PENCILS; CRAYONS; GLUE FOR STATIONERY USE; OFFICE REQUISITES IN THE NATURE OF CORRECTING FLUIDS FOR TYPE; PENCIL OR PEN BOXES; PICTURE POSTCARDS; BOOKS IN THE FIELD OF SELF-IMPROVEMENT, TRAVEL, HEALTH, HISTORY, CHILDREN'S BOOKS AND COMIC BOOKS; POSTCARDS; MAGAZINES IN THE FIELD OF SELF-IMPROVEMENT, TRAVEL, HEALTH, HISTORY, CHILDREN'S BOOKS AND COMIC BOOKS; STUDY BOOKS OR PAPERS IN THE FIELD OF SELF-IMPROVEMENT, TRAVEL, HEALTH, HISTORY, AND ART; PHOTOGRAPHS; MODELING CLAY; DRAWING INSTRUMENTS; BABIES' DIAPERS OF PAPER, DISPOSABLE NAPKINS AND WIPES NOT IMPREGNATED WITH CHEMICALS OR COMPOUNDS; PRINT ENGRAVING (U.S. CLS. 2, 5, 22, 23, 29, 37, 38 AND 50).

CLASS 18—LEATHER GOODS

FOR PORTABLE COSMETIC CASES SOLD EMPTY; ALL PURPOSE CARRYING BAGS; PURSES; BOXES MADE OF LEATHER; SACKS OF LEATHER FOR MERCHANDISE PACKAGING; LEATHER TRIMMINGS USED TO MAKE FURNITURE; COVERINGS OF LEATHER FOR BOOKS; LEATHER STRAPS FOR SKATES; UMBRELLAS; PARASOLS IN THE NATURE OF SUN UMBRELLAS; CANES; VALVES OF LEATHER, NAMELY, BELT BUCKLES; HORSE-RIDING EQUIPMENT, NAMELY, BRIDLES, REINS, LEADS, BITS, STIRRUP LEATHERS, HALTERS, LUNGE LINES (U.S. CLS. 1, 2, 3, 22 AND 41).

CLASS 25—CLOTHING

FOR MONEY BELTS IN THE NATURE OF CLOTHING; FOOTWEAR; SHORTS; HALF-LENGTH COATS; SUITS; SNOWBOARD SUITS; SKI WEAR; MEN'S SUITS; CHILDREN'S CLOTHING, NAMELY, SHIRTS AND PANTS; CEREMONIAL DRESSES; OVERCOATS; ONE PIECE SUITS FOR CHILDREN; WEDDING DRESSES; WORK CLOTHES, NAMELY, SHIRTS AND PANTS; JUMPERS; JACKETS AS CLOTHING; BLUE JEANS; COATS; TOP COATS; TWO PIECE SUITS; TRENCH COATS; PANTS; SPORTS WEAR FOR EXCLUSIVE USE FOR SPORTS, NAMELY, JERSEYS AND SOCCER SHORTS; KOREAN TRADITIONAL CLOTHES, NAMELY, CEREMONIAL DRESSES AND ROBES; SING-LETS; SHORT-SLEEVED SHIRTS; BLOUSES; SHIRTS; SWEATERS; SLEEPING GARMENTS; TRAINING WEAR, NAMELY, TRAINING SUITS; MORNING PAJAMAS; PANTIES; SCARVES; SOCKS; HEADWEAR, NAMELY, CAPS; MASKS FOR PROTECTION AGAINST THE COLD, NAMELY, SKI MASKS AND KNIT FACE MASKS; BELTS AS CLOTHING; LEATHER BELTS AS CLOTHING; SKI GLOVES (U.S. CLS. 22 AND 39).

CLASS 28—TOYS AND SPORTING GOODS

FOR TOY MASKS; REMOTE CONTROLLED TOYS FOR GAMES OTHER THAN THOSE ADAPTED FOR USE WITH TELEVISION RECEIVER, NAMELY, REMOTE CONTROL CAR, AIRPLANES, AND HELICOPTERS; CHILDREN'S MULTIPLE ACTIVITY TOYS MADE OF WOOD; WOODEN INFANT TOYS; TOY CONSTRUCTION AND MODEL TRAIN SETS; MODEL TOY VEHICLES FOR CHILDREN; ROCKING HORSES; TOY MUSICAL INSTRUMENTS, NAMELY, TOY PIANOS, TOY MODEL GUITARS; PAPER TOYS, NAMELY, PAPER DOLLS AND PAPER AIRPLANES; PLUSH TOYS; PLASTIC TOYS, NAMELY, BATH TOYS, CRIB TOYS, INFANT TOYS, RIDE-ON TOYS, SAND TOYS; METALLIC TOYS, NAMELY, TOY BANKS AND TOY MODEL CARS; REMOTE CONTROLLED TOYS OTHER THAN THOSE ADAPTED FOR USE WITH TELEVISION RECEIVER, NAMELY, REMOTE CONTROL TANKS; KALEIDOSCOPES; BOARD GAMES; BINGO CARDS; CONFETTI; BACKGAMMON GAMES; KITES; DICE; JIGSAW PUZZLES; PLAY BALLOONS; RACKETS; RUNNING MACHINES, NAMELY, EXERCISE TREADMILLS AND ELLIPTICAL EXERCISE MACHINES; ROWING MACHINES AS EXERCISING EQUIPMENT; ROLLER SKATES, WOODEN HORSES AS SPORTS ARTICLES, NAMELY, POMMEL HORSES; KNEE GUARDS FOR ATHLETIC AND SPORTS USE; SNOW SHOES; PLAYGROUND EQUIPMENT, NAMELY, SLIDES, BOWLING BAGS; BOWLING GLOVES; SURF BOARDS; BAGS ESPECIALLY DESIGNED FOR SURFING BOARDS; SURF SKIS; SKATEBOARDS; SQUASH RACKETS; SKIS; SLEIGHS AS SPORTS ARTICLES, NAMELY, BOB SLEIGHS; SPRING BOARDS AS SPORTS ARTICLES; ICE SKATES; SKIPPING ROPES; RODS FOR FISHING (U.S. CLS. 22, 23, 38 AND 50).

CLASS 38—COMMUNICATION

FOR DATA COMMUNICATION BY ELECTRONIC MAIL; WIRELESS BROADBAND COMMUNICATION SERVICES; VAN (VALUE ADDED NETWORK) COMMUNICATIONS, NAMELY, TRANSMISSION OF VOICE, DATA AND IMAGES BY MEANS OF TELECOMMUNICATIONS NETWORKS; REMOTE SCREEN COMMUNICATION, NAMELY, COMMUNICATIONS BY TELEVISION FOR MEETING; SATELLITE TRANSMISSION; INTERNET SERVICE PROVIDER SERVICES, NAMELY, PROVIDING USER ACCESS TO A GLOBAL COMPUTER NETWORK; RENTAL OF TELECOMMUNICATION EQUIPMENT; INFORMATION ABOUT TELECOMMUNICATION; ELECTRONIC MAIL; COMPUTER AIDED TRANSMISSION OF MESSAGES AND IMAGES; COMMUNICATIONS BY COMPUTER TERMINALS; TELEPRINTING SERVICES; TELECOMMUNICATIONS ROUTING AND JUNCTION SERVICES; INTERNET BROADCASTING; CELLULAR TELEPHONE COMMUNICATIONS; TELECOMMUNICATION SERVICES, NAMELY, ELECTRONIC BULLETIN BOARD SERVICES (U.S. CLS. 100, 101 AND 104).

MICHAEL LITZAU, EXAMINING ATTORNEY

SN 79-089,578. PIP STUDIO HOLDING B.V., NL-1087 HN AMSTERDAM, NETHERLANDS, FILED 8-6-2010.

PIP

THE MARK CONSISTS OF STANDARD CHARACTERS WITHOUT CLAIM TO ANY PARTICULAR FONT, STYLE, SIZE, OR COLOR.

PRIORITY DATE OF 7-15-2010 IS CLAIMED.
OWNER OF INTERNATIONAL REGISTRATION 1057185 DATED 8-6-2010, EXPIRES 8-6-2020.
THE WORD(S) "PIP" HAS NO MEANING IN A FOREIGN LANGUAGE.

CLASS 16—PAPER GOODS AND PRINTED MATTER

FOR PAPER, CARDBOARD AND ALL GOODS MADE FROM THESE MATERIALS, NOT INCLUDED IN OTHER CLASSES, NAMELY, PAPER BANNERS, PAPER BIBS, BOXES OF PAPER, CARDBOARD BOXES, CARDBOARD CARTONS AND CARDBOARD PACKAGING; PRINTED MATTER, NAMELY, MANUALS; COVERS FOR DIARIES AND ORGANIZERS, NAMELY, ORGANIZERS FOR STATIONERY USE AND PERSONAL ORGANIZERS; STATIONERY AND OFFICE REQUISITES, NAMELY, NOTEBOOKS; WRITING INSTRUMENTS, INCLUDING PENS, PENCILS AND FELT-TIP PENS; RING BINDERS, NAMELY, TWO, THREE AND MORE RING BINDERS; OFFICE REQUISITES, NAMELY, FOLDERS AND DOCUMENT FILES; ADHESIVE MATERIALS FOR HOUSEHOLD PURPOSES; LABELS NOT OF TEXTILE, NAMELY, PAPER LABELS, PRINTED PAPER LABELS, AND ADHESIVE LABELS; PENCIL CASES; PENCIL BOXES, PENCIL SHARPENERS, ERASERS; RULERS, NAMELY, DRAFTING RULERS, DRAWING RULERS, AND UNGRADUATED RULERS; PADS, NAMELY, DRAWING PADS, LEGAL PADS, NOTE PADS, AND SCRATCH PADS; OFFICE REQUISITES, NAMELY, MEMORANDUM BOARDS AND DESK PADS; CARDS, NAMELY, GREETING CARDS, NOTE CARDS; STICKERS; PICTURE POSTCARDS; ARTISTS' MATERIALS, NAMELY, PAINT BRUSHES (U.S. CLS. 2, 5, 22, 23, 29, 37, 38 AND 50).

CLASS 18—LEATHER GOODS

FOR LEATHER AND IMITATIONS OF LEATHER, AND GOODS MADE OF THESE MATERIALS AND NOT INCLUDED IN OTHER CLASSES, NAMELY, LEATHER BRIEFCASES, LEATHER CASES, LEATHER BAGS AND WALLETS, IMITATION LEATHER KEY CHAINS, AND IMITATION LEATHER SPORTS BAGS AND GENERAL PURPOSE TROLLEY BAGS; BAGS, NAMELY, SHOULDER BAGS, BEAUTY CASES, COSMETIC BAGS, HAND BAGS, ATHLETIC BAGS, BEACH BAGS, BOOK BAGS, DUFFEL BAGS AND RUCKSACKS; SUITCASES; PURSES, WALLETS, KEY CASES; UMBRELLAS; PARASOLS (U.S. CLS. 1, 2, 3, 22 AND 41).

CLASS 21—HOUSEWARES AND GLASS

FOR HOUSEHOLD OR KITCHEN CONTAINERS AND UTENSILS NOT OF PRECIOUS METAL OR COATED THEREWITH; COMBS AND SPONGES, NAMELY, BATH SPONGES, CLEANING SPONGES, SPONGE MASSAGERS; BRUSHES, NAMELY, DISHWASHING BRUSHES, CAKE BRUSHES, BRUSHES FOR PETS; GLASSWARE, PORCELAIN AND EARTHENWARE NOT INCLUDED IN OTHER CLASSES, NAMELY, BEVERAGE GLASSWARE, PORCELAIN DOORKNOBS, PORCELAIN EGGS, PORCELAIN MUGS, PORCELAIN PULLS, EARTHENWARE MUGS, PLATES, TEA POTS, JUGS, BOWLS (U.S. CLS. 2, 13, 23, 29, 30, 33, 40 AND 50).

CLASS 24—FABRICS

FOR TEXTILES AND TEXTILE GOODS, NAMELY, TEXTILE LABELS, TEXTILE PLACEMATS, TEXTILE SERVIETTES; HOUSEHOLD TEXTILES, NAMELY, TABLECLOTHS, TEXTILE WALL HANGINGS, AND TEXTILE NAPKINS, KITCHEN TOWELS, TEA TOWELS, DISH TOWELS, HAND TOWELS, POTHOLDERS; BED LINEN, INCLUDING DUVET COVERS, FITTED SHEETS, SHEETS AND PILLOWCASES; COVERS FOR CUSHIONS; BLANKETS, NAMELY, BED BLANKETS, LAP BLANKETS, PET BLANKETS, SILK BLANKETS, AND TRAVELLING BLANKETS AND BEDSPREADS; QUILTS; TRAVEL RUGS; TABLE CLOTH NOT OF PAPER, PLASTIC TABLE COVERS AND TABLE NAPKINS OF TEXTILE; BATH LINEN, INCLUDING TOWELS, BATH SHEETS AND WASHING MITTS; FURNITURE COVERS, NAMELY, THROWS; FURNISHING FABRICS, CURTAINS AND CURTAIN FABRICS, WALL COVERING, NAMELY, CLOTH POSTERS (U.S. CLS. 42 AND 50).

CLASS 25—CLOTHING

FOR CLOTHING, NAMELY, NIGHTWEAR, LINGERIE, APRONS, BATHING SUITS; FOOTWEAR, HEADWEAR (U.S. CLS. 22 AND 39).
WARREN L. OLANDRIA, EXAMINING ATTORNEY

THE MARK CONSISTS OF THE WORDING "WORK HAPPINESS" IN STYLIZED FONT.

CLASS 35—ADVERTISING AND BUSINESS

FOR BUSINESS MANAGEMENT ANALYSIS AND BUSINESS CONSULTANCY; PROVIDING INFORMATION ON BUSINESS MANAGEMENT, BUSINESS MANAGEMENT ANALYSIS AND BUSINESS CONSULTANCY; PROVIDING INFORMATION CONCERNING COMMERCIAL SALES OF GOODS AND PRESENTATION OF GOODS ON COMMUNICATION MEDIA, FOR RETAIL PURPOSES (U.S. CLS. 100, 101 AND 102).

CLASS 41—EDUCATION AND ENTERTAINMENT

FOR EDUCATIONAL SERVICES, NAMELY, PROVIDING CLASSES IN THE FIELD OF BUSINESS TRAINING AND CAREER COUNSELING; PHYSICAL EDUCATION; ARRANGING, CONDUCTING AND ORGANIZATION OF SEMINARS IN THE FIELD OF BUSINESS TRAINING; PUBLICATION OF BOOKS (U.S. CLS. 100, 101 AND 107).

WILLIAM BRECKENFELD, EXAMINING ATTORNEY

SN 79-089,647. ASTRUM SAS, FRANCE, FILED 10-8-2010.

ADELINE

THE MARK CONSISTS OF STANDARD CHARACTERS WITHOUT CLAIM TO ANY PARTICULAR FONT, STYLE, SIZE, OR COLOR.

PRIORITY DATE OF 4-28-2010 IS CLAIMED.

OWNER OF INTERNATIONAL REGISTRATION 1057365 DATED 10-8-2010, EXPIRES 10-8-2020.

THE WORDING "ADELINE" HAS NO MEANING IN A FOREIGN LANGUAGE.

CLASS 12—VEHICLES

FOR SEMI-REUSABLE SPACE VEHICLES (U.S. CLS. 19, 21, 23, 31, 35 AND 44).

CLASS 39—TRANSPORTATION AND STORAGE

FOR LAUNCHING OF AND PLACEMENT IN PRESCRIBED ORBIT OF SEMI-REUSABLE SATELLITES OR SPACE VEHICLES FOR OTHERS (U.S. CLS. 100 AND 105).

CLASS 42—SCIENTIFIC AND COMPUTER SERVICES

FOR ENGINEERING AND RESEARCH AND DEVELOPMENT SERVICES IN THE FIELD OF SEMI-REUSABLE SPACE VEHICLES (U.S. CLS. 100 AND 101).
CHARISMA HAMPTON, EXAMINING ATTORNEY

SN 79-089,750. MORIRIN CO., LTD., AICHI-KEN 491-8610, JAPAN, FILED 3-29-2010.

VIA NATURA

THE MARK CONSISTS OF STANDARD CHARACTERS WITHOUT CLAIM TO ANY PARTICULAR FONT, STYLE, SIZE, OR COLOR.

PRIORITY DATE OF 3-9-2010 IS CLAIMED.

OWNER OF INTERNATIONAL REGISTRATION 1057660 DATED 3-29-2010, EXPIRES 3-29-2020.

THE ENGLISH TRANSLATION OF "VIA NATURA" IN THE MARK IS "NATURAL WAY".

CLASS 23—YARNS AND THREADS

FOR THREADS AND YARNS FOR TEXTILE USE; COTTON THREADS AND YARNS; HEMP THREADS AND YARNS; SILK THREADS AND YARNS; SPUN WOOL; WORSTED THREAD; WOOLLEN THREAD AND YARN; CHEMICAL FIBER THREADS AND YARNS FOR TEXTILE USE; INORGANIC FIBER THREADS AND YARNS FOR TEXTILE USE; MIXED SPUN THREADS AND YARNS; TWISTED THREADS AND YARNS; SEWING THREAD AND YARN; RUBBER THREAD FOR TEXTILE USE; PAPER YARN FOR TEXTILE USE; GILT THREAD FOR TEXTILE USE; SILVER FOIL THREAD FOR TEXTILE USE; MISCELLANEOUS THREADS AND YARNS FOR TEXTILE USE; COVERED RUBBER THREAD AND YARN FOR TEXTILE USE; DEGREASED WASTE THREADS AND YARNS (U.S. CL. 43).

SN 79-089,731. S-POOL RESEARCH INSTITUTE, INC., TOKYO 105-0013, JAPAN, FILED 8-10-2010.

WORK HAPPINESS

OWNER OF INTERNATIONAL REGISTRATION 1057609 DATED 8-10-2010, EXPIRES 8-10-2020.

NO CLAIM IS MADE TO THE EXCLUSIVE RIGHT TO USE "WORK", APART FROM THE MARK AS SHOWN.

CLASS 24—FABRICS

FOR COTTON FABRICS; HEMP YARN FABRICS; SILK FABRICS; WOOL YARN FABRICS; CHEMICAL FIBER FABRICS; INORGANIC FIBER FABRICS; MIXED FIBER FABRICS; MIXED YARN FABRICS; NARROW WOVEN FABRICS; PAPER YARN FABRICS FOR TEXTILE USE; COVERED RUBBER YARN FABRICS FOR TEXTILE USE; KNITTED FABRICS; FELT AND NON-WOVEN TEXTILE FABRICS; TOWELS OF TEXTILE; HANDKERCHIEFS; BATH LINEN, EXCEPT CLOTHING; BEDSHEETS; FUTON QUILTS; QUILTS; FUTON AND QUILTS CASES IN THE NATURE OF DUVET COVERS; UNFITTED FUTON COVERS NOT OF PAPER; PILLOW-CASES; BED BLANKETS; TABLE NAPKINS OF TEXTILE; DISH CLOTHS FOR DRYING; UNFITTED SEAT COVERS OF TEXTILE; WALL HANGINGS OF TEXTILE; CURTAINS; TABLECLOTH NOT OF PAPER; DRAPERIES (U.S. CLS. 42 AND 50).

CLASS 25—CLOTHING

FOR NON-JAPANESE STYLE OUTER CLOTHING, NAMELY, COATS AND JACKETS; EVENING DRESSES; SCHOOL UNIFORMS; CHILDREN'S WEAR, NAMELY, PANTS, SKIRTS AND TOPS; WORKING CLOTHING, NAMELY, COVERALLS; JACKETS; JOGGING PANTS; SWEAT PANTS; SUITS; SKIRTS; SKI JACKETS; SKI PANTS; TROUSERS; SMOCKS; FORMAL WEAR, NAMELY, GOWNS AND TUXEDOS; OVERCOATS; TOPCOATS; MANTLES; RAINCOATS; CARDIGANS; SWEATERS; VESTS; SHIRTS; OPEN NECKED SHIRTS; CUFFS; COLLARS FOR CLOTHING; SPORT SHIRTS; BLOUSES; POLO SHIRTS; SHIRTS FOR SUITS; NIGHTWEAR; NIGHT GOWNS; NEGLIGEEES; BATH ROBES; UNDERWEAR; UNDERSHIRTS; CHEMISES; UNDERPANTS; PANTIES, SHORTS AND BRIEFS; BRASSIERES; PETTICOATS; BATHING SUITS; SWIMWEAR; SWIMMING CAPS; SLEEP MASKS; APRONS; SOCKS AND STOCKINGS; PUTTEES AND GAITERS; FUR STOLEES; SHAWLS; SCARFS; JAPANESE STYLE SOCKS, NAMELY, TABI; JAPANESE STYLE SOCKS COVERS, NAMELY, TABI COVERS; GLOVES AND MITTENS; BABIES' DIAPERS OF TEXTILE; NECKTIES; NECKERCHIEVES; BANDANAS; MUFFLERS; EAR MUFFS; HOODS; NIGHTCAPS; HEADGEAR FOR WEAR, NAMELY, HATS AND CAPS; WAISTBANDS; BELTS FOR CLOTHING; RAIN BOOTS; LACE BOOTS; TRAINING SHOES; OVERSHOES; WOODEN SHOES; WORK SHOES AND BOOTS; SANDALS; SHOES; JAPANESE SPLIT-TOED WORK FOOTWEAR, NAMELY, JIKATABI; ANGLERS' SHOES; BOOTS; HALF-BOOTS; WOMEN'S SHOES; WINTER BOOTS; CANVAS SHOES; INFANTS' SHOES AND BOOTS; INNER SOLES FOR SHOES AND BOOTS; HEELPIECES FOR SHOES AND BOOTS; INSOLES FOR SHOES AND BOOTS; WELTS FOR SHOES AND BOOTS; RUBBER SOLES FOR JIKATABI; FOOTWEAR UPPERS; TIPS FOR FOOTWEAR; SOLES FOR SHOES, OTHER THAN ORTHOPAEDIC; CLOTHES FOR SPORTS, NAMELY, SPORTS OVER UNIFORMS; ANORAKS; KARATE SUITS; SPORTS OVER UNIFORMS; KENDO OUTFITS; JUDO SUITS; SKI SUITS FOR COMPETITION; HEADBANDS; WIND-JACKETS; UNIFORMS AND STOCKINGS; WRISTBANDS (U.S. CLS. 22 AND 39).
FRED CARL, EXAMINING ATTORNEY

SN 79-089,774. BORREGAARD INDUSTRIES LIMITED, NORGE, NORWAY, FILED 6-25-2010.

SENSEFI

THE MARK CONSISTS OF STANDARD CHARACTERS WITHOUT CLAIM TO ANY PARTICULAR FONT, STYLE, SIZE, OR COLOR.

PRIORITY DATE OF 1-8-2010 IS CLAIMED.
OWNER OF INTERNATIONAL REGISTRATION 1057725 DATED 6-25-2010, EXPIRES 6-25-2020.

THE WORDING "SENSEFI" HAS NO MEANING IN A FOREIGN LANGUAGE.

CLASS 1—CHEMICALS

FOR CHEMICALS USED IN INDUSTRY, NAMELY, EXCIPIENTS FOR USE IN THE MANUFACTURE OF PHARMACEUTICAL PREPARATIONS AND VETERINARY PREPARATIONS; CHEMICALS USED IN INDUSTRY, EXCEPT SEMI-MANUFACTURED PRODUCTS FOR HAIR CARE; CHEMICALS USED IN SCIENCE AND PHOTOGRAPHY; CHEMICALS USED IN AGRICULTURE, HORTICULTURE AND FORESTRY EXCEPT FUNGICIDES, HERBICIDES, INSECTICIDES AND PARACITDIES; CHEMICAL SUBSTANCES FOR PRESERVING FOODSTUFFS; ADHESIVES USED IN INDUSTRY; ACETATE OF CELLULOSE UNPROCESSED; AGAR-AGAR; ALGINATES FOR USE IN THE MANUFACTURE OF FOOD, FEED, PERSONAL CARE PRODUCTS AND COSMETIC PRODUCTS; ADHESIVES USED IN INDUSTRY; BIOLOGICAL PREPARATIONS FOR USE IN CELL CULTURE OTHER THAN FOR MEDICAL OR VETERINARY PURPOSES; CELLULOSE; CELLULOSE DERIVATIVES, NAMELY, CARBOXYMETHYL CELLULOSE, METHYL CELLULOSE, HYDROXYPROPYMETHYL CELLULOSE AND MICROCRYSTALLINE CELLULOSE; CELLULOSE ESTERS FOR INDUSTRIAL PURPOSES; DEXTRIN; EMULSIFIERS AND EMULSIFICATION AGENTS USED IN THE MANUFACTURE OF FOOD, FEED, PERSONAL CARE PRODUCTS AND COSMETIC PRODUCTS; PRESERVATIVES FOR PHARMACEUTICALS (U.S. CLS. 1, 5, 6, 10, 26 AND 46).

CLASS 5—PHARMACEUTICALS

FOR SANITARY PREPARATIONS FOR MEDICAL PURPOSES; DIETETIC FOODS ADAPTED FOR MEDICAL USE, FOOD FOR BABIES; DIETETIC BEVERAGES FOR MEDICAL USE; DIETETIC SUGAR FOR MEDICAL USE; NUTRITIONAL ADDITIVES FOR ANIMAL FOOD; FOOD ADDITIVES FOR MEDICAL USE; NON-NUTRITIVE DIETARY FIBER AS AN ADDITIVE FOR FOOD PRODUCTS; NON-NUTRITIVE DIETARY PLANT FIBER AS AN ADDITIVE FOR FOOD PRODUCTS; PHARMACEUTICALS FOR WEIGHT LOSS (U.S. CLS. 6, 18, 44, 46, 51 AND 52).

CLASS 29—MEATS AND PROCESSED FOODS

FOR MEAT, FISH, POULTRY AND GAME; MEAT EXTRACTS; PRESERVED, FROZEN, DRIED AND COOKED FRUITS AND VEGETABLES; JELLIES, JAMS, COMPOTES; EGGS, MILK AND MILK PRODUCTS EXCLUDING ICE CREAM, ICE MILK AND FROZEN YOGURT; EDIBLE OILS AND FATS; UNFLAVORED AND UNSWEETENED GELATIN; CAVIAR; ALGINATES SOLD AS AN INGREDIENT FOR FOODS; FRUIT PECTIN FOR FOOD; BOUILLON, MILK-BASED BEVERAGES, BEVERAGES PRIMARILY CONTAINING MILK; MARGARINE; EDIBLE FATS; TINNED MEAT; SAUSAGES; BUTTER; SOYA MILK; SOUPS; YOGHURT (U.S. CL. 46).

CLASS 30—STAPLE FOODS

FOR COFFEE, TEA, COCOA, SUGAR, RICE, TAPIOCA, SAGO, ARTIFICIAL COFFEE; FLOUR; PREPARATIONS MADE FROM CEREALS, NAMELY, BREAD AND PASTRY; CONFECTIONERY, NAMELY, CANDY, EDIBLE ICES; HONEY, TREACLE; YEAST, BAKING POWDER; SALT, MUSTARD; VINEGAR, SAUCES; SPICES; ICE; STARCH-BASED AND CELLULOSE BASED BINDING AGENTS FOR SAUSAGES; STARCH-BASED BINDING AGENTS FOR ICE CREAM AND EDIBLE ICES; DRESSINGS FOR SALAD; COFFEE-BASED BEVERAGES, COCOA-BASED BEVERAGES; FROZEN YOGHURT; FOOD LEAVENING AGENTS FOR PASTRY AND CONFECTIONERY; ICE CREAM; KETCHUP; MEAT GRAVIES; MEAT PIES; SORBET MIXES; TOMATO SAUCE; CORN STARCH FOR USE AS A THICKENING AGENT FOR COOKING FOODSTUFFS; MAYONNAISE; MALT FOR HUMAN CONSUMPTION; LICORICE; CONFECTIONERY, NAMELY, PASTILLES; PUDDINGS; STARCH FOR FOOD (U.S. CL. 46).

CLASS 31—NATURAL AGRICULTURAL PRODUCTS

FOR FOODSTUFFS FOR ANIMALS; BEVERAGES FOR PETS; FODDER; NON-MEDICAL ADDITIVES FOR FODDER; FODDER CAKES; FOODSTUFFS FOR BIRDS, DOMESTIC ANIMALS AND PETS; LIVESTOCK; RAPE CAKES IN THE NATURE OF SEEDS COMPRESSED TOGETHER FOR USE AS BIRD FOOD (U.S. CLS. 1 AND 46).

FRED CARL, EXAMINING ATTORNEY

SN 79-089,821. GMS MANAGEMENT SOLUTIONS S.L., E-28020 MADRID, SPAIN, FILED 7-15-2010.



PRIORITY DATE OF 6-21-2010 IS CLAIMED.
OWNER OF INTERNATIONAL REGISTRATION 1057875 DATED 7-15-2010, EXPIRES 7-15-2020.

NO CLAIM IS MADE TO THE EXCLUSIVE RIGHT TO USE "MANAGEMENT SOLUTIONS", APART FROM THE MARK AS SHOWN.

THE COLOR(S) BLUE AND GOLD IS/ARE CLAIMED AS A FEATURE OF THE MARK.

THE MARK CONSISTS OF A CIRCLE AND DOT DESIGN IN BLUE AND GOLD COLORS. THE STYLIZED WORDINGS "MS", "SOLUTIONS", AND "MAKING THINGS HAPPEN" ARE IN BLUE AND "MANAGEMENT" IS IN GOLD COLOR.

CLASS 9—ELECTRICAL AND SCIENTIFIC APPARATUS

FOR RECORDED COMPUTER PROGRAMS FOR DATABASE MANAGEMENT, FOR DOCUMENT MANAGEMENT, AND FOR USE AS A SPREADSHEET, ALL FOR USE IN THE FIELD OF BUSINESS MANAGEMENT; DOWNLOADABLE SOFTWARE FOR USE IN DATABASE MANAGEMENT AND FOR USE AS A SPREADSHEET IN THE FIELD OF BUSINESS MANAGEMENT; BLANK OPTICAL DATA CARRIERS; BLANK MAGNETIC DATA CARRIERS (U.S. CLS. 21, 23, 26, 36 AND 38).

CLASS 16—PAPER GOODS AND PRINTED MATTER

FOR EDUCATIONAL PUBLICATIONS, NAMELY, FLASH CARDS FOR EDUCATIONAL PURPOSES; FLASH CARDS FOR EDUCATIONAL ASSISTANCE; ANNOUNCEMENT CARDS; WORKBOOKS, TEXT BOOKS, ACTIVITY BOOKS AND TEACHER GUIDES FOR TEACHERS, ALL IN THE FIELD OF BUSINESS MANAGEMENT; STORY BOOK; EDUCATIONAL HANDBOOKS, POSTERS AND PAMPHLETS IN THE FIELD OF BUSINESS MANAGEMENT; PRINTED TEACHING MATERIALS IN THE FIELD OF BUSINESS MANAGEMENT (U.S. CLS. 2, 5, 22, 23, 29, 37, 38 AND 50).

CLASS 35—ADVERTISING AND BUSINESS

FOR ASSISTANCE, ADVISORY SERVICES AND CONSULTING RELATING TO BUSINESS PLANNING, BUSINESS APPRAISALS, BUSINESS MANAGEMENT AND BUSINESS ORGANIZATION; CONSULTATION IN THE FIELD OF MARKET ASSESSMENT SERVICES AND CONSUMER SURVEY SERVICES; COMMERCIAL ASSISTANCE IN BUSINESS MANAGEMENT; INDUSTRIAL MANAGEMENT ASSISTANCE; ASSISTANCE IN MANAGEMENT OF BUSINESS ACTIVITIES, ADVISORY SERVICES AND CONSULTING, ALL RELATING TO THE PLACEMENT AND RECRUITMENT OF PERSONNEL IN THE FIELD OF BUSINESS MANAGEMENT; MARKET RESEARCH; BUSINESS MANAGEMENT AND ENTERPRISE ORGANIZATION CONSULTANCY; CONSULTING ON ACCOUNTING; PROVIDING INFORMATION AND NEWS IN THE FIELD OF BUSINESS, NAMELY, INFORMATION AND NEWS ON CURRENT AFFAIRS AND WITH REGARD TO ECONOMIC, LEGISLATIVE AND REGULATORY DEVELOPMENTS THAT MAY AFFECT BUSINESS; CONSULTING ON BUSINESS RISK MANAGEMENT; BUSINESS ACQUISITION AND MERGERS CONSULTATION; ARRANGING AND CONDUCTING BUSINESS CONFERENCES (U.S. CLS. 100, 101 AND 102).

CLASS 36—INSURANCE AND FINANCIAL

FOR FISCAL EVALUATIONS AND ASSESSMENTS; FINANCIAL CONSULTATION; INSURANCE CONSULTATION; REAL ESTATE CONSULTATION; FINANCIAL CLEARING HOUSES; BANKING CONSULTATION; FINANCIAL VALUATIONS, FINANCIAL FORECASTING, ANALYSIS, CONSULTING AND RESEARCH SERVICES RELATING TO BONDS AND OTHER FINANCIAL INVESTMENT PRODUCTS; FINANCIAL AND INVESTMENT SERVICES, NAMELY, MANAGEMENT IN THE FIELDS OF STOCKS, BONDS, OPTIONS, COMMODITIES, FUTURES AND OTHER SECURITIES, AND THE INVESTMENT OF FUNDS FOR OTHERS; LAND VALUATION AND MANAGEMENT OF REAL ESTATE; BUSINESS BROKERAGE SERVICES AND RELATED CONSULTING PERTAINING TO BUSINESS SALES, MERGERS AND ACQUISITIONS (U.S. CLS. 100, 101 AND 102).

CLASS 41—EDUCATION AND ENTERTAINMENT

FOR EDUCATIONAL SERVICES, NAMELY, DEVELOPING AND DISSEMINATION OF TEACHING MATERIALS OF OTHERS, ALL IN THE FIELD OF BUSINESS MANAGEMENT; PUBLICATION OF TEXT BOOKS, BOOKS AND MAGAZINES; VIDEO TAPE RECORDING FOR OTHERS FOR TEACHING PURPOSES IN THE FIELD OF BUSINESS MANAGEMENT; EDUCATION SERVICES, NAMELY, CONDUCTING DISTANCE LEARNING INSTRUCTION AT THE GRADUATE LEVELS IN THE FIELD OF BUSINESS MANAGEMENT (U.S. CLS. 100, 101 AND 107).

CLASS 42—SCIENTIFIC AND COMPUTER SERVICES

FOR COMPUTER PROGRAMMING SERVICES; CONSULTING SERVICES IN THE FIELD OF ENVIRONMENTAL PLANNING AND ASSESSMENT; COMPUTER HARDWARE AND SOFTWARE CONSULTING SERVICES; ENGINEERING SERVICES FEATURING PLANNING TECHNICAL PROJECTS IN THE FIELD OF BUSINESS MANAGEMENT SERVICES; QUALITY CONTROL FOR OTHERS; DESIGN, DEVELOPMENT, INSTALLATION AND MAINTENANCE OF COMPUTER SOFTWARE; BUSINESS TECHNOLOGY SOFTWARE CONSULTATION SERVICES (U.S. CLS. 100 AND 101).

CLASS 45—PERSONAL AND LEGAL SERVICES

FOR PROVIDING INFORMATION RELATING TO LEGAL AFFAIRS; CONSULTING SERVICES IN THE FIELD OF LISTING AND TRACKING OF DOMESTIC LOCAL GOVERNMENT REGULATORY REQUIREMENTS, FOR OBTAINING PERMITS AND TO ENSURE COMPLIANCE (U.S. CLS. 100 AND 101).

DAWN HAN, EXAMINING ATTORNEY

SN 79-089,849. OSHCHESTVO S OGRANICHENNOY OTVETSTVENNOSTYU "TSMD LABS.", RUSSIAN FED., FILED 9-16-2010.

ALEKSEY KOROLYOV

PRIORITY DATE OF 4-28-2010 IS CLAIMED.

OWNER OF INTERNATIONAL REGISTRATION 1057971 DATED 9-16-2010, EXPIRES 9-16-2020.

THE NAME(S), PORTRAIT(S), AND/OR SIGNATURE(S) SHOWN IN THE MARK IDENTIFIES "ALEKSEY KOROLYOV", WHOSE CONSENT(S) TO REGISTER IS MADE OF RECORD.

THE MARK CONSISTS OF THE WORDING "ALEKSEY KOROLYOV" IN STYLIZED FONT.

CLASS 35—ADVERTISING AND BUSINESS

FOR ADVERTISING; BUSINESS MANAGEMENT; BUSINESS ADMINISTRATION; OFFICE FUNCTIONS (U.S. CLS. 100, 101 AND 102).

CLASS 38—COMMUNICATION

FOR TELECOMMUNICATION SERVICES, NAMELY, TRANSMISSION OF VOICE, DATA, GRAPHICS, IMAGES, AUDIO AND VIDEO BY MEANS OF TELECOMMUNICATIONS NETWORKS, WIRELESS COMMUNICATION NETWORKS, AND THE INTERNET (U.S. CLS. 100, 101 AND 104).

CLASS 42—SCIENTIFIC AND COMPUTER SERVICES

FOR SCIENTIFIC RESEARCH AND DEVELOPMENT; DESIGN AND TESTING FOR NEW PRODUCT DEVELOPMENT; INDUSTRIAL RESEARCH IN THE FIELD OF SOFTWARE FOR TELECONFERENCING AND TELEPRESENCE CONFERENCING SERVICES; DESIGN AND DEVELOPMENT OF COMPUTER HARDWARE AND SOFTWARE (U.S. CLS. 100 AND 101).

STEVEN PEREZ, EXAMINING ATTORNEY

SN 79-089,876. OI OI PTY LTD, AUSTRALIA, FILED 8-25-2010.



THE MARK CONSISTS OF STANDARD CHARACTERS WITHOUT CLAIM TO ANY PARTICULAR FONT, STYLE, SIZE, OR COLOR.

PRIORITY DATE OF 7-23-2010 IS CLAIMED.

OWNER OF INTERNATIONAL REGISTRATION 1058043 DATED 8-25-2010, EXPIRES 8-25-2020.

OWNER OF U.S. REG. NOS. 2,827,743 AND 3,250,634.

CLASS 16—PAPER GOODS AND PRINTED MATTER

FOR PAPER, CARDBOARD AND GOODS MADE FROM THESE MATERIALS, NAMELY, DISPOSABLE BABIES' DIAPERS OF PAPER AND CELLULOSE; STATIONERY; PHOTO ALBUMS; GREETING CARDS, GIFT CARDS AND GIFT WRAPPING PAPER; PAPER BAGS AND PAPERBOARD BOXES FOR PACKAGING; BLACKBOARDS; BOOKS FOR INFANTS AND CHILDREN; BABY RECORD BOOKS; BOOKMARKERS; BOTTLE WRAPPERS OF CARDBOARD OR PAPER; PEN AND PENCIL CASES AND HOLDERS; CALENDARS; DOCUMENT FILES AND FOLDERS; WRITING INSTRUMENTS; PAPER LABELS; WRITING PADS AND STATIONERY; POSTERS; DRAWING RULERS; RUBBER ERASERS; SCHOOL SUPPLY KITS CONTAINING VARIOUS COMBINATIONS OF SELECTED SCHOOL SUPPLIES, NAMELY, WRITING INSTRUMENTS, PENS, PENCILS, MECHANICAL PENCILS, ERASERS, MARKERS, CRAYONS, HIGHLIGHTER PENS, FOLDERS, NOTEBOOKS, PAPER, PROTRACTORS, PAPER CLIPS, PENCIL SHARPENERS, WRITING GRIPS, GLUE AND BOOK MARKS; SCRAPBOOKS; TABLE CLOTHS, MATS AND NAPKINS OF PAPER; BABY PAPER BIBS (U.S. CLS. 2, 5, 22, 23, 29, 37, 38 AND 50).

CLASS 21—HOUSEWARES AND GLASS

FOR CONTAINERS FOR HOUSEHOLD USE; HOUSEHOLD UTENSILS, NAMELY, MIXING SPOONS, SPATULAS; CAKE MOLDS, CONFECTIONERS' MOLDS, COOKERY MOLDS, ICE CUBE MOLDS, CUPS, PLATES, BOWLS, STORAGE POTS AND GENERAL PURPOSE STORAGE BINS FOR HOUSEHOLD USE; BABY AND INFANT FEEDING AND NON-SPILL DRINKING CUPS; BOTTLES, SOLD EMPTY; INSULATING SLEEVE HOLDERS FOR BOTTLES; DRINKING GLASSES, NAMELY, TUMBLERS; GLASS JARS; GLASS CAPS, SPOUTS AND CLOSURES FOR CUPS, BABY AND INFANT FEEDING CUPS, FOR BOWLS, BOTTLES, BOTTLES FOR FEEDING BABIES AND INFANTS, AND JARS AND TUMBLERS; HAIR BRUSHES AND COMBS (U.S. CLS. 2, 13, 23, 29, 30, 33, 40 AND 50).

CLASS 24—FABRICS

FOR TEXTILES AND TEXTILE GOODS, NOT INCLUDED IN OTHER CLASSES, NAMELY, BATH LINEN, BED LINEN, TABLE LINEN; BABY BEDDING, NAMELY, BUNDLE BAGS, SWADDLING BLANKETS, CRIB BUMPERS, FITTED CRIB SHEETS, CRIB SKIRTS, CRIB BLANKETS, AND DIAPER CHANGING PAD COVERS NOT OF PAPER; BED AND PLASTIC TABLE COVERS; TABLE CLOTHS OF TEXTILE; FACE TOWELS, TEA TOWELS, HAND TOWELS, BATH TOWELS; FABRIC FLAGS; HANDKERCHIEFS; HOUSEHOLD AND TABLE LINEN; CURTAINS; TABLE MATS NOT MADE OF PAPER; CLOTH COASTERS (U.S. CLS. 42 AND 50).

CLASS 25—CLOTHING

FOR CLOTHING, NAMELY, BABIES' DIAPERS OF TEXTILE, BIBS NOT OF PAPER, BABY CLOTHING, BABY BODYSUITS, BABY BOTTOMS, BABY BUNTING, BABY TOPS, BABY LAYETTES, LEGGINGS, TIGHTS, SINGLETTS, PYJAMAS, DRESSING GOWNS, BATHING SUITS, DRESSES, SKIRTS, SHIRTS, TEE-SHIRTS, PANTS, COATS, SWEATERS; FOOTWEAR AND HEADWEAR (U.S. CLS. 22 AND 39).

CLASS 28—TOYS AND SPORTING GOODS

FOR GAMES AND PLAYTHINGS, NAMELY, BOARD GAMES, BUILDING GAMES, CARD GAMES; TOYS, NAMELY, BUILDING BLOCKS, MOBILES, SCOOTERS, BUBBLE MAKING WAND AND SOLUTION SETS, SPINNING TOPS; TOY MASKS, TOY PISTOLS, TOY VEHICLES; DOLLS; PLUSH TOYS; PUPPETS; TEDDY BEARS; BABY PLAYTHINGS, NAMELY, BABY MULTIPLE ACTIVITY TOYS, BABY RATTLES, BABY TEETHERS; BABY SWINGS; DECORATIONS FOR CHRISTMAS TREES (U.S. CLS. 22, 23, 38 AND 50).

LINDA M. KING, EXAMINING ATTORNEY

SN 79-089,892. KEMMAX GMBH, FED REP GERMANY,
FILED 9-24-2010.

CHEMTRADE AGLOBIS

THE MARK CONSISTS OF STANDARD CHARACTERS WITHOUT CLAIM TO ANY PARTICULAR FONT, STYLE, SIZE, OR COLOR.

PRIORITY DATE OF 7-5-2010 IS CLAIMED.

OWNER OF INTERNATIONAL REGISTRATION 1058087
DATED 9-24-2010, EXPIRES 9-24-2020.

THE WORD "AGLOBIS" HAS NO MEANING IN A FOREIGN LANGUAGE.

CLASS 1—CHEMICALS

FOR INDUSTRIAL CHEMICALS; SULPHUR; SULPHURIC ACID (U.S. CLS. 1, 5, 6, 10, 26 AND 46).

CLASS 39—TRANSPORTATION AND STORAGE

FOR TRANSPORT BROKERAGE; TRUCK HAULING; BOAT TRANSPORT (U.S. CLS. 100 AND 105).

CHRISTOPHER BUONGIORNO, EXAMINING ATTORNEY

CLASS 3—COSMETICS AND CLEANING PREPARATIONS

FOR BLEACHING PREPARATIONS AND OTHER SUBSTANCES FOR LAUNDRY USE, NAMELY, GENERAL PURPOSE DETERGENT, BLEACH, FABRIC SOFTENER, STAIN REMOVER, STARCH AND COLOR BRIGHTENING CHEMICALS; ALL-PURPOSE CLEANING PREPARATIONS; POLISHING, SCOURING AND ABRASIVE PREPARATIONS; SOAP, PERFUMERY; ESSENTIAL OILS; COSMETICS; HAIR LOTIONS; DENTIFICES; SHAVING PREPARATIONS; TOILET WATER; COTTON STICKS FOR COSMETIC PURPOSES; BEAUTY MASKS; COSMETIC SUN-TANNING PREPARATIONS; COSMETIC PREPARATIONS FOR SKIN CARE; HAIR COLOURING AND DYES; SHOE POLISH AND CREAMS; SHOE WAX; SHAMPOOS; COSMETIC KITS, NAMELY, MAKE UP KITS COMPRISED OF LIPSTICK, LIP GLOSS, EYE SHADOW, BLUSH, EYELINER, COSMETIC PENCILS, MAKE-UP FOUNDATION, MAKE-UP POWDER, FALSE EYELASHES, BEAUTY MASKS AND NAIL VARNISH; DEPILATORY PREPARATIONS; MAKE-UP REMOVING PREPARATIONS; DEODORANTS FOR PERSONAL USE; LIPSTICKS; COSMETIC PENCILS; HAIR AND NAIL LACQUERS; LACQUER-REMOVING PREPARATIONS; TISSUES IMPREGNATED WITH COSMETIC LOTIONS; AFTER-SHAVE LOTIONS; LOTIONS FOR COSMETIC PURPOSES; MAKE-UP PREPARATIONS; POMADES FOR COSMETIC PURPOSES; SACHETS FOR PERFUMING LINEN; NAIL CARE PREPARATIONS; COBBLERS' WAX; BOOT CREAMS IN THE NATURE OF BOOT POLISH; BLEACHING PREPARATIONS FOR COSMETIC PURPOSES; PERFUMED EXTRACTS OF FLOWERS FOR PERFUMES; INCENSE; SCENTED WOOD; DECORATIVE TRANSFERS FOR COSMETIC PURPOSES; FALSE NAILS AND EYELASHES; PUMICE STONES FOR PERSONAL USE; POTPOURRI; COSMETIC PREPARATIONS FOR SLIMMING PURPOSES; NON-MEDICATED COSMETIC PREPARATIONS FOR BATHS; HAIR WAVING PREPARATIONS; CLEANING AND WASHING PREPARATIONS; NON-MEDICATED TOILETRIES; COSMETIC PREPARATIONS FOR THE CARE OF MOUTH; BATH SALTS; HYGIENIC PRODUCTS FOR CLEANING PURPOSES, NAMELY, DISINFECTANT SOAPS, DISINFECTING PERFUMED SOAPS AND NAIL SANITIZING PREPARATIONS; OILS FOR TOILET PURPOSES, NAMELY, COSMETIC OILS AND AROMATHERAPY OILS; COSMETIC SUNSCREEN PREPARATIONS; EAU DE COLOGNE; DEODORANT SOAP; TALCUM POWDER FOR TOILETRY USE (U.S. CLS. 1, 4, 6, 50, 51 AND 52).

SN 79-089,915. INDUSTRIA DE DISEÑO TEXTIL, S.A.
(INDITEX, S.A.), SPAIN, FILED 9-2-2010.

ZARA FOR MUM

THE MARK CONSISTS OF STANDARD CHARACTERS WITHOUT CLAIM TO ANY PARTICULAR FONT, STYLE, SIZE, OR COLOR.

OWNER OF INTERNATIONAL REGISTRATION 1058099
DATED 9-2-2010, EXPIRES 9-2-2020.

OWNER OF U.S. REG. NOS. 1,629,592, 2,038,110 AND OTHERS.

THE ENGLISH TRANSLATION OF "ZARA" IN THE MARK IS MAIZE OR INDIAN CORN.

CLASS 18—LEATHER GOODS

FOR LEATHER AND IMITATION LEATHER; ANIMAL SKINS; TRUNKS AND TRAVELLING BAGS; UMBRELLAS, PARASOLS AND WALKING STICKS; WHIPS, HARNESSES AND SADDLERY; CLIMBING AND CAMPING BAGS IN THE NATURE OF BACKPACKS; BEACH BAGS; HANDBAG FRAMES; FRAMES FOR UMBRELLAS OR PARASOLS; ALPENSTOCKS; PURSES; BAGS, NAMELY, LEATHER AND IMITATION LEATHER BAGS; TRAVEL CASES; KEY CASES; ATTACHE CASES; COIN PURSES, NOT OF PRECIOUS METAL; SCHOOL SATCHELS; GARMENT BAGS FOR TRAVEL; HAT BOXES OF LEATHER; SLING BAGS FOR CARRYING INFANTS; WHEELED SHOPPING BAGS; LEATHER OR LEATHER-BOARD BOXES; BOXES OF VULCANIZED FIBER; SCHOOL BAGS; POCKET WALLETS; BRIEF-CASES; UNFITTED VANITY CASES; COLLARS FOR ANIMALS; LEATHER ANIMAL LEASHES; LEATHER ANIMAL LEADS; UMBRELLA COVERS; SADDLE CLOTHS FOR HORSES IN THE NATURE OF SADDLE COVERS; HAVERSACKS; HORSE BLANKETS; BACKPACKS; CASES FOR MUSICAL INSTRUMENTS; HORSE HALTERS; BAGS FOR PACKAGING OF LEATHER; RIDING SADDLES (U.S. CLS. 1, 2, 3, 22 AND 41).

CLASS 25—CLOTHING

FOR READY-TO-WEAR CLOTHING FOR MEN, WOMEN AND CHILDREN, NAMELY, OVERALLS, TOPS, VESTS, UNDERSHIRTS, UNDERPANTS, TROUSERS, SHIRTS, DRESSES, SUNDRESSES, SLACKS, PANTS, BLOUSES, SHIRTS, T-SHIRTS, SWEATERS, WAISTCOATS, PULLOVERS, CARDIGANS, JERSEYS, JACKETS, SUITS, TUXEDOS, OVERCOATS, COATS, HUNTING JACKETS, TRACK SUITS, ASCOTS, PONCHOS, SKIRTS, JEANS, SHORTS AND TRENCH COATS; FOOTWEAR; HEADGEAR, NAMELY, HATS, SCARVES, KERCHIEFS, EAR MUFFS, CAPS, HEADBANDS, CAP VISORS AND CAP PEAKS; CLOTHING FOR MOTORISTS AND CYCLISTS, NAMELY, JACKETS AND MOTORCYCLE GLOVES; BIBS, NOT OF PAPER; BATH ROBES; BATHING SUITS; BATHING CAPS AND SANDALS; BOAS; UNDERWEAR; BABY PANTS; SASHES FOR WEAR; SPORTS FOOTWEAR; BEACH SHOES; HOODS; SHAWLS; BELTS; MONEY BELTS; WETSUITS FOR WATER-SKIING; NECKTIES; CORSETS; MUFFLERS; FUR STOLEES; GIRDLES; GLOVES; WATERPROOF CLOTHING, NAMELY, RAINCOATS AND RAIN SUITS; UNDERWEAR, MANTILLAS; STOCKINGS; SOCKS; ASCOTS; INFANT CLOTH DIAPERS; POCKET SQUARES; FURS, NAMELY, FUR COATS AND JACKETS; PAJAMAS; SOLES FOR FOOTWEAR; HEELS; VEILS; BRACES FOR CLOTHING; PAPER CLOTHING, NAMELY, PAPER HATS, PAPER SHOES AND PAPER UNDERWEAR; GYMNAS TIC AND SPORTS OUTFITS, NAMELY, LEOTARDS; LAYETTES; SHOULDER WRAPS, SPORTS SHIRTS, MITTENS; EAR WARMERS; INNER SOLES; BOW TIES; PAREUS; WRISTBANDS; DRESS SHIELDS; MASQUERADE COSTUMES; BEACH CLOTHES, NAMELY, BEACH COVERUPS AND BEACH FOOTWEAR; VISORS (U.S. CLS. 22 AND 39).

CLASS 35—ADVERTISING AND BUSINESS

FOR ADVERTISING SERVICES; BUSINESS ADMINISTRATION AND MANAGEMENT; PROVIDING OFFICE FUNCTIONS; RETAIL STORE SERVICES IN THE FIELDS OF GAMES AND PLAYTHINGS, CLOTHING, CLOTHING ACCESSORIES, HAIR ORNAMENTS, PERSONAL CARE PRODUCTS, LEATHER GOODS, LUGGAGE AND BAGS, CANDLES AND CANDLE WICKS, UMBRELLAS, FOOTWEAR, HEADGEAR, JEWELRY, CLOCKS AND WATCHES, COSMETICS, FRAGRANCES, SUNGLASSES AND EYEGASSES, HOUSEWARES, CHRISTMAS TREE DECORATIONS, GYMNAS TIC EQUIPMENT, SPORTING EQUIPMENT AND PROTECTIVE HELMETS, HEADPHONES AND COMPACT DISCS; RETAIL STORE SERVICES PROVIDED VIA GLOBAL COMPUTER NETWORKS, CATALOGUE, MAIL ORDER, TELEPHONE, RADIO AND TELEVISION IN THE FIELDS OF GAMES AND PLAYTHINGS, CLOTHING, CLOTHING ACCESSORIES, HAIR ORNAMENTS, PERSONAL CARE PRODUCTS, LEATHER GOODS, LUGGAGE AND BAGS, CANDLES AND CANDLE WICKS, UMBRELLAS, FOOTWEAR, HEADGEAR, JEWELRY, CLOCKS AND WATCHES, COSMETICS, FRAGRANCES, SUNGLASSES AND EYEGASSES, HOUSEWARES, CHRISTMAS TREE DECORATIONS, GYMNAS TIC EQUIPMENT, SPORTING EQUIPMENT AND PROTECTIVE HELMETS, HEADPHONES AND COMPACT DISCS; BUSINESS MANAGEMENT CONSULTING; ORGANIZATION OF EXHIBITIONS FOR COMMERCIAL OR ADVERTISING PURPOSES; PROMOTING THE SALE OF GOODS AND SERVICES OF OTHERS BY MEANS OF THE ISSUANCE OF CUSTOMER LOYALTY CARDS; MODELING SERVICES FOR ADVERTISING AND SALES PROMOTION; PUBLISHING OF ADVERTISING TEXTS; SHOW WINDOW DISPLAY ARRANGEMENT SERVICES; ASSISTANCE IN BUSINESS MANAGEMENT AND PRODUCT COMMERCIALIZATION WITHIN THE FRAMEWORK OF A FRANCHISE CONTRACT; DEMONSTRATION OF GOODS, NAMELY, PRODUCT DEMONSTRATION; ORGANIZATION OF TRADE FAIRS FOR COMMERCIAL OR ADVERTISING PURPOSES; SALES PROMOTION SERVICES; AUCTIONEERING; PROMOTION SERVICES FOR COMMERCIAL CENTERS; BUSINESS MANAGEMENT OF COMMERCIAL CENTERS; IMPORT-EXPORT AGENCIES; ONLINE ADVERTISING ON A COMPUTER NETWORK; PROCUREMENT SERVICES, NAMELY, PURCHASING GAMES AND PLAYTHINGS, CLOTHING, CLOTHING ACCESSORIES, HAIR ORNAMENTS, PERSONAL CARE PRODUCTS,

LEATHER GOODS, LUGGAGE AND BAGS, CANDLES AND CANDLE WICKS, UMBRELLAS, FOOTWEAR, HEADGEAR, JEWELRY, CLOCKS AND WATCHES, COSMETICS, FRAGRANCES, SUNGLASSES AND EYEGASSES, HOUSEWARES, CHRISTMAS TREE DECORATIONS, GYMNAS TIC EQUIPMENT, SPORTING EQUIPMENT AND PROTECTIVE HELMETS, HEADPHONES AND COMPACT DISCS FOR OTHERS; ARRANGING NEWSPAPER SUBSCRIPTIONS FOR OTHERS (U.S. CLS. 100, 101 AND 102).

MATTHEW MCDOWELL, EXAMINING ATTORNEY

SN 79-089,921. CISSOID, SOCIÉTÉ ANONYME, BELGIUM, FILED 10-26-2010.

STROMBOLI

THE MARK CONSISTS OF STANDARD CHARACTERS WITHOUT CLAIM TO ANY PARTICULAR FONT, STYLE, SIZE, OR COLOR.

PRIORITY DATE OF 5-25-2010 IS CLAIMED.

OWNER OF INTERNATIONAL REGISTRATION 1058118 DATED 10-26-2010, EXPIRES 10-26-2020.

CLASS 9—ELECTRICAL AND SCIENTIFIC APPARATUS

FOR ANALOG AND DIGITAL INTEGRATED CIRCUITS; MICROELECTRONIC CIRCUITS; APPLICATION-SPECIFIC INTEGRATED CIRCUITS (ASIC); ELECTRIC CONVERTERS (U.S. CLS. 21, 23, 26, 36 AND 38).

CLASS 37—CONSTRUCTION AND REPAIR

FOR INSTALLATION, MAINTENANCE AND REPAIR OF INTEGRATED CIRCUITS AND ELECTRIC CONVERTERS AS WELL AS RELATED TECHNICAL SUPPORT SERVICES (U.S. CLS. 100, 103 AND 106).

CLASS 42—SCIENTIFIC AND COMPUTER SERVICES

FOR DESIGN AND DEVELOPMENT OF INTEGRATED CIRCUITS, APPLICATION-SPECIFIC INTEGRATED CIRCUITS (ASIC), ELECTRIC CONVERTERS; TECHNICAL INFORMATION, ADVICE AND CONSULTING RELATING TO THE AFORESAID SERVICES; SCIENTIFIC AND INDUSTRIAL RESEARCH IN ELECTRONICS AND MICROELECTRONICS (U.S. CLS. 100 AND 101).

DAVID HOFFMAN, EXAMINING ATTORNEY

SN 79-089,927. SIEMENS AKTIENGESELLSCHAFT, FED REP GERMANY, FILED 9-1-2010.

TAMS

THE MARK CONSISTS OF STANDARD CHARACTERS WITHOUT CLAIM TO ANY PARTICULAR FONT, STYLE, SIZE, OR COLOR.

PRIORITY DATE OF 3-4-2010 IS CLAIMED.

OWNER OF INTERNATIONAL REGISTRATION 1058124 DATED 9-1-2010, EXPIRES 9-1-2020.

CLASS 9—ELECTRICAL AND SCIENTIFIC APPARATUS

FOR COMPUTER HARDWARE, COMPUTER SOFTWARE AND COMPUTER PERIPHERALS FOR MANAGING AIRPORT OPERATIONS AND ANALYZING AND OPTIMIZING AIRPORT PROCESSES; COMMUNICATIONS COMPUTERS (U.S. CLS. 21, 23, 26, 36 AND 38).

CLASS 42—SCIENTIFIC AND COMPUTER SERVICES

FOR CREATION, DEVELOPMENT AND DESIGN OF COMPUTER PROGRAMS AND SOFTWARE FOR OTHERS; IMPLEMENTATION, LEASING, UPDATING AND MAINTENANCE OF COMPUTER PROGRAMS AND SOFTWARE; RESEARCH IN THE FIELDS OF COMPUTER PROGRAMS AND SOFTWARE; INTERNET SERVICES, NAMELY, CONVERSION OF DATA AND COMPUTER PROGRAMS EXCLUDING PHYSICAL CHANGES; CONVERSION OF DATA FROM PHYSICAL TO ELECTRONIC MEDIA, COMPRESSION OF DATA FOR ELECTRONIC STORAGE; ENCRYPTION OF DATA; SOFTWARE AND EDP (ELECTRONIC DATA PROCESSING) EDITING, NAMELY, EDITING, UPDATING, ADAPTING OF PROGRAMS FOR DATA PROCESSING; SERVICES OF AN ELECTRONIC DATA PROCESSING PROGRAMMER, NAMELY, COMPUTER PROGRAMMING SERVICES; STORAGE OF ELECTRONICALLY STORED DATA FOR THIRD PARTIES; ELECTRONIC ARCHIVING OF ELECTRONICALLY STORED DATA FOR BACK-UP PURPOSES; LEASING OF DATA PROCESSING SYSTEMS; TECHNICAL DESIGN OF TELECOMMUNICATION SYSTEMS AND DEVICES; TECHNICAL COMPUTER AND ELECTRONIC NETWORK PLANNING; CREATION OF INTERACTIVE, ELECTRONIC, USER-ORIENTED SOFTWARE; TECHNICAL CONSULTANCY SERVICES AND RENDERING OF EXPERT OPINIONS IN THE FIELD OF INFORMATION TECHNOLOGY, COMPUTER SYSTEMS, AND COMPUTER SOFTWARE SUITES FOR AIRPORT MANAGEMENT AND OPTIMIZATION OF AIRPORT PROCESSES; DESIGN OF COMPUTER SYSTEMS AND COMMUNICATION STRUCTURES IN THE NATURE OF TELECOMMUNICATION APPLIANCES, MACHINES AND DEVICES; STORAGE OF DATA IN COMPUTER DATABASES, NAMELY, REMOTE COMPUTER BACKUP SERVICES (U.S. CLS. 100 AND 101).

JACLYN KIDWELL WALKER, EXAMINING ATTORNEY

SN 79-090,003, UFI FILTERS S.P.A., I-46047 PORTO MANTOVANO (MANTOVA), ITALY, FILED 10-7-2010.

SOFIMA

THE MARK CONSISTS OF STANDARD CHARACTERS WITHOUT CLAIM TO ANY PARTICULAR FONT, STYLE, SIZE, OR COLOR.

PRIORITY DATE OF 9-1-2010 IS CLAIMED.
OWNER OF INTERNATIONAL REGISTRATION 1058327 DATED 10-7-2010, EXPIRES 10-7-2020.

CLASS 1—CHEMICALS

FOR CHEMICAL PREPARATIONS IN THE NATURE OF FILTERING MATERIALS TO BE USED IN THE AUTOMOTIVE INDUSTRY, BUS TRANSPORTATION INDUSTRY, TRANSPORTATION INDUSTRY, AERONAUTIC INDUSTRY, FOOD AND BEVERAGE INDUSTRY; UNPROCESSED PLASTICS IN THE NATURE OF FILTERING MATERIALS TO BE USED IN THE AUTOMOTIVE INDUSTRY, BUS TRANSPORTATION INDUSTRY, TRANSPORTATION INDUSTRY, AERONAUTIC INDUSTRY, FOOD AND BEVERAGE INDUSTRY; MINERAL SUBSTANCES IN THE NATURE OF FILTERING MATERIALS TO BE USED IN THE AUTOMOTIVE INDUSTRY, BUS TRANSPORTATION INDUSTRY, TRANSPORTATION INDUSTRY, AERONAUTIC INDUSTRY, FOOD AND BEVERAGE INDUSTRY; VEGETABLE SUBSTANCES IN THE NATURE OF FILTERING MATERIALS TO BE USED IN THE AUTOMOTIVE INDUSTRY, BUS TRANSPORTATION INDUSTRY, TRANSPORTATION INDUSTRY, AERONAUTIC INDUSTRY, FOOD AND BEVERAGE INDUSTRY (U.S. CLS. 1, 5, 6, 10, 26 AND 46).

CLASS 7—MACHINERY

FOR FILTERS FOR MACHINES, ENGINES AND MOTORS USED IN THE AUTOMOTIVE INDUSTRY, BUS TRANSPORTATION INDUSTRY, TRANSPORTATION INDUSTRY, AERONAUTIC INDUSTRY, FOOD AND BEVERAGE INDUSTRY; FUEL FILTERS; OIL FILTERS; AIR FILTERS FOR CLEANING COOLING AIR IN ENGINES OR MOTORS; AIR FILTERS FOR MOTORS OR ENGINES; FILTERS FOR MOTORS OR ENGINES; CARTRIDGES FOR FILTERING MACHINES (U.S. CLS. 13, 19, 21, 23, 31, 34 AND 35).

ELLEN PERKINS, EXAMINING ATTORNEY

SN 79-090,095, FUZHOU F&V PHOTOGRAPHIC EQUIPMENT CO., LTD., 350008 FUJIAN, CHINA, FILED 9-24-2010.

F&V

OWNER OF INTERNATIONAL REGISTRATION 1058631 DATED 9-24-2010, EXPIRES 9-24-2020.
THE MARK CONSISTS OF "F&V".

CLASS 9—ELECTRICAL AND SCIENTIFIC APPARATUS

FOR LUMINOUS SIGNS FOR ADVERTISING OR BULLETINS; TRANSMITTERS OF ELECTRONIC SIGNALS; FLASH BULBS FOR PHOTOGRAPHY; STANDS FOR PHOTOGRAPHIC APPARATUS; TRIPODS FOR CAMERAS; FLASHLIGHTS FOR PHOTOGRAPHY; BAGS ESPECIALLY ADAPTED FOR PHOTOGRAPHIC APPARATUS; OPTICAL CONDENSERS; REMOTE CONTROL APPARATUS FOR PHOTOGRAPHIC EQUIPMENT; BATTERIES (U.S. CLS. 21, 23, 26, 36 AND 38).

CLASS 11—ENVIRONMENTAL CONTROL APPARATUS

FOR LAMP SHADES; LIGHT DIFFUSERS; LIGHTING APPARATUS, NAMELY, LIGHTING INSTALLATIONS; PROJECTOR LAMPS; LUMINOUS TUBES FOR LIGHTING; ELECTRIC LIGHTS FOR CHRISTMAS TREES; DIVING LIGHTS; LIGHTING APPARATUS FOR THEATRICAL STAGE; REFLECTOR SPOTLIGHTS FOR USE IN PHOTOGRAPHY (U.S. CLS. 13, 21, 23, 31 AND 34).

CHRISTOPHER BUONGIORNO, EXAMINING ATTORNEY

SN 79-090,156. SAINT GENTLEMAN CO., LTD., JAPAN, FILED 8-24-2010.

GENTOS

THE MARK CONSISTS OF STANDARD CHARACTERS WITHOUT CLAIM TO ANY PARTICULAR FONT, STYLE, SIZE, OR COLOR.

PRIORITY DATE OF 7-8-2010 IS CLAIMED.

OWNER OF INTERNATIONAL REGISTRATION 1058785 DATED 8-24-2010, EXPIRES 8-24-2020.

THE WORDING "GENTOS" HAS NO MEANING IN A FOREIGN LANGUAGE.

CLASS 9—ELECTRICAL AND SCIENTIFIC APPARATUS

FOR ELECTRONIC DESK CALCULATORS, AND THE OTHER ELECTRONIC MACHINES AND APPARATUS, NAMELY, ELECTRONIC DESK CALCULATORS, PHOTO-SENSITIVE TUBES, RECTIFIER TUBES, DISCHARGE TUBES, DIODES, AND PARTS THEREFOR; BATTERIES AND CELLS, NAMELY, DRY CELLS, BATTERIES, AND PHOTOVOLTAIC CELLS; TELECOMMUNICATION DEVICES AND APPARATUS, NAMELY, RADIO RECEIVERS, COMPACT DISC PLAYERS, SOUND RECORDING MACHINES, VIDEO CAMERAS, VIDEODISC PLAYERS, NAVIGATION APPARATUS FOR VEHICLES, AND RADIO BEACON MACHINES (U.S. CLS. 21, 23, 26, 36 AND 38).

CLASS 11—ENVIRONMENTAL CONTROL APPARATUS

FOR ELECTRIC LAMPS AND OTHER LIGHTING APPARATUS, NAMELY, POCKET SEARCH LIGHTS, SPOTLIGHTS, DIVING LIGHTS, SEARCHLIGHTS, INCANDESCENT LAMPS AND THEIR FITTINGS, DISCHARGE LAMPS AND THEIR FITTINGS, MINIATURE LIGHT BULBS, LED BULBS, AND LED FLASHLIGHTS (U.S. CLS. 13, 21, 23, 31 AND 34).

CLASS 14—JEWELRY

FOR CLOCKS AND WATCHES; ORNAMENTS OF PRECIOUS METAL; JEWELLERY; TRINKETS OR FOBS, NAMELY, KEYRINGS OF PRECIOUS METAL (U.S. CLS. 2, 27, 28 AND 50).

BERNICE MIDDLETON, EXAMINING ATTORNEY

SN 79-090,184. LUIGI LAVAZZA S.P.A., TORINO, ITALY, FILED 10-13-2010.

ESPRESSO EXPERIENCE

THE MARK CONSISTS OF STANDARD CHARACTERS WITHOUT CLAIM TO ANY PARTICULAR FONT, STYLE, SIZE, OR COLOR.

PRIORITY DATE OF 5-14-2010 IS CLAIMED.

OWNER OF INTERNATIONAL REGISTRATION 1058877 DATED 10-13-2010, EXPIRES 10-13-2020.

NO CLAIM IS MADE TO THE EXCLUSIVE RIGHT TO USE "ESPRESSO", APART FROM THE MARK AS SHOWN.

CLASS 30—STAPLE FOODS

FOR COFFEE, COFFEE BLENDS, DECAFFEINATED COFFEE AND COFFEE EXTRACTS (U.S. CL. 46).

CLASS 41—EDUCATION AND ENTERTAINMENT

FOR ORGANIZATION OF CULTURAL, ARTISTIC AND ENTERTAINMENT EVENTS, IN THE FIELD OF PROMOTING COFFEE (U.S. CLS. 100, 101 AND 107).

MORGAN WYNNE, EXAMINING ATTORNEY

SN 79-090,220. LUIGI LAVAZZA S.P.A., TORINO, ITALY, FILED 10-13-2010.



PRIORITY DATE OF 5-25-2010 IS CLAIMED.

OWNER OF INTERNATIONAL REGISTRATION 1058966 DATED 10-13-2010, EXPIRES 10-13-2020.

NO CLAIM IS MADE TO THE EXCLUSIVE RIGHT TO USE "ITALIAN ESPRESSO", APART FROM THE MARK AS SHOWN.

THE MARK CONSISTS OF A STYLIZED WAVE WITH THE WORDING "THE ITALIAN ESPRESSO EXPERIENCE" AT THE TOP OF THE WAVE.

CLASS 30—STAPLE FOODS

FOR COFFEE, COFFEE BLENDS, DECAFFEINATED COFFEE AND COFFEE EXTRACTS (U.S. CL. 46).

CLASS 41—EDUCATION AND ENTERTAINMENT

FOR ORGANIZATION OF CULTURAL, ARTISTIC AND ENTERTAINMENT EVENTS, IN THE FIELD OF PROMOTING COFFEE (U.S. CLS. 100, 101 AND 107).

MORGAN WYNNE, EXAMINING ATTORNEY

SN 79-090,248. CRP HENRI TUDOR, LUXEMBOURG, FILED 10-4-2010.

TIPA

THE MARK CONSISTS OF STANDARD CHARACTERS WITHOUT CLAIM TO ANY PARTICULAR FONT, STYLE, SIZE, OR COLOR.

PRIORITY DATE OF 6-16-2010 IS CLAIMED.

OWNER OF INTERNATIONAL REGISTRATION 1059098 DATED 10-4-2010, EXPIRES 10-4-2020.

CLASS 9—ELECTRICAL AND SCIENTIFIC APPARATUS

FOR COMPUTER SOFTWARE AND COMPUTER PROGRAMS FOR INFORMATION TECHNOLOGY (IT) STANDARDS BASED PROCESS ASSESSMENT, FOR IT SERVICE MANAGEMENT PROCESS ASSESSMENT, FOR ASSESSMENT OF OPERATIONAL RISK MANAGEMENT FOR IT, AND FOR ASSESSMENT OF IT SECURITY AND GOVERNANCE PROCESSES; OPTICAL DATA MEDIA FEATURING CONTENT RELATED TO IT SERVICE MANAGEMENT AND STANDARDS BASED PROCESS ASSESSMENT; MAGNETIC DATA MEDIA FEATURING CONTENT RELATED TO IT SERVICE MANAGEMENT AND STANDARDS BASED PROCESS ASSESSMENT; DOWNLOADABLE USER MANUALS IN THE FIELD OF IT STANDARDS BASED PROCESS ASSESSMENT, IT SERVICE MANAGEMENT PROCESS ASSESSMENTS, ASSESSMENT OF OPERATIONAL RISK MANAGEMENT FOR IT, AND ASSESSMENT OF IT SECURITY AND GOVERNANCE PROCESSES (U.S. CLS. 21, 23, 26, 36 AND 38).

CLASS 35—ADVERTISING AND BUSINESS

FOR BUSINESS ADMINISTRATION AND MANAGEMENT; PROVIDING OFFICE FUNCTIONS; BUSINESS INFORMATION AND INQUIRIES; EFFICIENCY EXPERTS; COMPILATION AND SYSTEMIZATION OF INFORMATION INTO COMPUTER DATABASES; COMPUTERIZED FILE MANAGEMENT; BUSINESS ORGANIZATIONAL CONSULTING; ASSESSMENT OF AND ASSISTANCE WITH BUSINESS SERVICE PROCEDURES; BUSINESS MANAGEMENT ASSISTANCE; BUSINESS RESEARCH FOR ENHANCING QUALITY OF SERVICES; COMMERCIAL ADMINISTRATION OF THE LICENSING OF GOODS AND SERVICES OF OTHERS (U.S. CLS. 100, 101 AND 102).

CLASS 41—EDUCATION AND ENTERTAINMENT

FOR EDUCATION AND TRAINING, NAMELY, ORGANIZATION OF CONFERENCES, CONGRESSES, SEMINARS, SYMPOSIA, AND WORKSHOPS IN THE FIELD OF BUSINESS MANAGEMENT SERVICES, INCLUDING ASSESSMENT TECHNIQUES, ASSESSMENT OF PROCEDURES, QUALITY CONTROL, MODELS AND STANDARDS MANAGEMENT PROCEDURES, FACILITATIVE TOOLS AND METHODOLOGIES; PUBLICATION OF TEXTS, OTHER THAN ADVERTISING TEXTS; PUBLICATION OF BOOKS; ONLINE PUBLICATION OF ELECTRONIC BOOKS AND PERIODICALS (U.S. CLS. 100, 101 AND 107).

CLASS 42—SCIENTIFIC AND COMPUTER SERVICES

FOR SCIENTIFIC AND TECHNOLOGICAL SERVICES, NAMELY, RESEARCH AND DESIGN IN THE FIELD OF IT PROCESS ASSESSMENT, IT SERVICE ASSESSMENT AND IT GOVERNANCE, INDUSTRIAL RESEARCH SERVICES IN THE FIELD OF IT PROCESS ASSESSMENT, IT SERVICE MANAGEMENT, AND IT GOVERNANCE; DESIGN AND DEVELOPMENT OF COMPUTERS AND SOFTWARE; INSTALLATION, MAINTENANCE AND UPDATING OF COMPUTER SOFTWARE; RENTAL OF COMPUTER SOFTWARE; CONSULTING IN THE FIELD OF COMPUTER SOFTWARE; RESEARCH AND DEVELOPMENT IN THE SCIENTIFIC FIELD OF IT PROCESS ASSESSMENT, IT SERVICE MANAGEMENT AND IT GOVERNANCE (U.S. CLS. 100 AND 101).

JASON BLAIR, EXAMINING ATTORNEY

SN 79-090,272. TATEHANA NORITAKA, JAPAN, FILED 9-15-2010.

NORITAKA TATEHANA

PRIORITY DATE OF 9-10-2010 IS CLAIMED.

OWNER OF INTERNATIONAL REGISTRATION 1059183 DATED 9-15-2010, EXPIRES 9-15-2020.

THE NAME "NORITAKA TATEHANA" IDENTIFIES A LIVING INDIVIDUAL WHOSE CONSENT IS OF RECORD.

CLASS 18—LEATHER GOODS

FOR CARRY-ON BAGS; TRUNKS; HANDBAGS; BOSTON BAGS; CALLING CARD CASES, MEMBERSHIP CARD CASES AND CREDIT CARD CASES; WALLETS; TRANSPORTATION CARD CASES; BUSINESS CARD CASES (U.S. CLS. 1, 2, 3, 22 AND 41).

CLASS 25—CLOTHING

FOR EVENING DRESSES; JACKETS; SUITS; SKIRTS; TROUSERS; OVERCOATS; MANTLES; CARDIGANS; SWEATERS; VESTS AND WAISTCOATS; OPEN-NECKED SHIRTS; CUFFS; COLLARS FOR CLOTHING; BLOUSES; SHAWLS; SCARVES; GLOVES AND MITTENS; MUFFLERS; HATS AND CAPS; BELTS FOR CLOTHING; RAIN BOOTS; LACE BOOTS; SPORTS SHOES; SANDALS; WOMEN'S SHOES; CANVAS SHOES (U.S. CLS. 22 AND 39).

SUZANNE BLANE, EXAMINING ATTORNEY

SN 79-090,300. SEGA CORPORATION, JAPAN, FILED 7-14-2010.

SONIC THE HEDGEHOG

PRIORITY DATE OF 6-10-2010 IS CLAIMED.

OWNER OF INTERNATIONAL REGISTRATION 1059285 DATED 7-14-2010, EXPIRES 7-14-2020.

OWNER OF U.S. REG. NOS. 3,308,413, 3,891,288 AND OTHERS.

CLASS 14—JEWELRY

FOR PRECIOUS METALS; KEY RINGS OF PRECIOUS METALS; TROPHIES OF PRECIOUS METALS; COMMEMORATIVE SHIELDS OF PRECIOUS METALS; NONE-MONETARY COINS; PERSONAL ORNAMENTS OF PRECIOUS METALS; BADGES OF PRECIOUS METAL; ORNAMENTAL PINS; WRISTWATCHES; WATCHES; CLOCKS (U.S. CLS. 2, 27, 28 AND 50).

CLASS 16—PAPER GOODS AND PRINTED MATTER

FOR INDUSTRIAL PACKAGING CONTAINERS OF PAPER; PRINTED MATTER, NAMELY, BOOKS, MAGAZINES AND NEWSLETTERS FEATURING ANIMATION, VIDEO GAMES, COMPUTER GAMES, ARCADE GAMES, BOARD GAMES AND CARD GAMES; CALENDARS; POSTERS; COMIC BOOKS; PAPER AND CARDBOARD; STICKERSSTATIONARY; NOTE BOOKS; STATIONARY; PHOTOGRAPHS; PHOTOGRAPH STANDS; BANNERS OF PAPER; FLAGS OF PAPER; TOWELS OF PAPER; HANDKERCHIEFS OF PAPER (U.S. CLS. 2, 5, 22, 23, 29, 37, 38 AND 50).

CLASS 18—LEATHER GOODS

FOR BAGS AND THE LIKE, NAMELY, HANDBAGS, SCHOOL BAGS, BACKPACKS, TRAVELING BAGS, ATTACHÉ BAGS, BAGS OF LEATHER FOR PACKAGING, LUGGAGE OF LEATHER, SHOULDER BAGS, CARRY-ON BAGS, RUCKSACKS, COURIER BAGS, MESSENGER BAGS, TRAINER BAGS, SPORTS BAGS; POUCHES AND THE LIKE, NAMELY, VINYL AND CANVAS POUCHES, POUCHES OF LEATHER, POUCHES OF TEXTILE; CARD CASES, NAMELY, CREDIT CARD CASES, BUSINESS CARD CASES, NAME CARD CASES; KEY CASES; PURSES; WALLETS; UMBRELLAS; CLOTHING FOR PETS; UNFITTED VANITY CASES (U.S. CLS. 1, 2, 3, 22 AND 41).

CLASS 20—FURNITURE AND ARTICLES NOT OTHERWISE CLASSIFIED

FOR FURNITURE; BEDDING, EXCEPT LINEN, NAMELY, MATTRESSES AND BOX SPRINGS; CUSHIONS; PILLOWS; DRINKING STRAWS; NON-ELECTRIC FANS FOR PERSONAL USE; INDOOR WINDOW BLINDS; BEAD CURTAINS FOR DECORATION; BENCHES; PICTURE FRAMES (U.S. CLS. 2, 13, 22, 25, 32 AND 50).

CLASS 21—HOUSEWARES AND GLASS

FOR TABLEWARE OTHER THAN KNIVES FORKS AND SPOONS, NAMELY, PLATES, CUP AND SAUCERS; UTENSILS FOR HOUSEHOLD PURPOSE, NAMELY, POT AND PAN SCRAPERS, ROLLING PINS, SPATULAS, TURNERS, WHISKS, BOTTLES, SOLD EMPTY, BOWLS, LUNCH BOXES; PIGGY BANKS, NOT OF METAL; COSMETIC UTENSILS, NAMELY COSMETIC BRUSHES, TOOTH BRUSHES AND DENTAL FLOSS (U.S. CLS. 2, 13, 23, 29, 30, 33, 40 AND 50).

CLASS 24—FABRICS

FOR CURTAINS; TABLE CLOTHS OF TEXTILE; LINEN FOR HOUSEHOLD PURPOSES; TOWELS; HANDKERCHIEFS; QUILTS; QUILT COVERS; PILLOWCASES; BED BLANKETS; SERVIETTES OF TEXTILE; LABELS OF CLOTH (U.S. CLS. 42 AND 50).

CLASS 25—CLOTHING

FOR CLOTHING, NAMELY, T-SHIRTS, SHIRTS, PANTS, JEANS, JACKETS, COATS, DRESSES, SKIRTS, SOCKS, GLOVES AS CLOTHING, VESTS, UNDERWEAR, ANORAKS, RAIN WEAR, WIND RESISTANT JACKETS, SWEATSHIRTS, TANK TOPS, PULLOVERS, SWEATERS, KNIT SHIRTS, CARDIGANS, BELTS, PARKAS, MUFFLERS, FLEECE PULLOVERS, HEAD WEAR, PAJAMAS; CLOTHES FOR SPORTS, NAMELY, PANTS, SPORTS OVER UNIFORMS, JERSEYS, SHIRTS, COATS, JACKETS, SWIM WEARS, BATHING SUITS; SHOES; BOOTS; FOOTWEAR FOR SPORTS (U.S. CLS. 22 AND 39).

CLASS 28—TOYS AND SPORTING GOODS

FOR AMUSEMENT GAME MACHINES AND COIN-OPERATED AMUSEMENT MACHINES FOR USE IN AMUSEMENT PARKS; TOYS FOR DOMESTIC PETS; TOYS, NAMELY, ELECTRONIC ACTION TOYS, INFLATABLE TOYS, MECHANICAL ACTION TOYS AND PARTS THEREFORE, TOY MASKS, PUZZLES, TOY BUILDING BLOCKS, BOARD GAMES; ACTION FIGURES; ELECTRONIC ACTION TOYS; DOLLS; STUFFED TOYS; PLAYING CARDS; BILLIARD EQUIPMENT; DARTS; SPORTS EQUIPMENT, NAMELY, BASEBALL GLOVES, BASEBALLS, SOFTBALLS, RUBBER BASEBALLS, BATTING GLOVES, BASEBALL BACKSTOPS, BASEBALL BATS, BASEBALL BAT CASES, BASEBALL BASES, CATCHERS' MASKS, BASEBALL MITTS, CHEST PROTECTORS FOR BASEBALL, SKIPPING ROPES, YOGA MATS, HEAD COVERS FOR GOLF CLUBS, GOLF BAGS, EXERCISE BALLS, ROLLER SKATES, SKATEBOARDS, ROLLER BLADES, BALLS FOR GAMES, BASKETBALL HOOPS; BASKETBALL NETS; BASKETBALL BACKBOARDS; TENNIS RACKETS (U.S. CLS. 22, 23, 38 AND 50).

CLASS 30—STAPLE FOODS

FOR TEA; COFFEE AND COCOA; CONFECTIONERY MADE OF SUGAR; BREAD AND BUNS; PANCAKES; ICE CREAM; CHOCOLATE; COOKIES; POPCORN; SANDWICHES; SUSHI; HAMBURGERS SANDWICHES; PIZZAS; HOT DOGS; ICE CREAM MIXES; SHERBET MIXES; OAT FLAKES; OATMEAL; CORN FLAKES; SPAGHETTI; MACARONI; ALMOND PASTE (U.S. CL. 46).

CLASS 32—LIGHT BEVERAGES

FOR BEER; CARBONATED SOFT DRINKS; NON-ALCOHOLIC FRUIT JUICE BEVERAGES; WHEY BEVERAGES; VEGETABLE JUICES; NON-ALCOHOLIC BEVERAGES; NAMELY, FRUIT-FLAVORED SOFT DRINKS AND SODA WATER, COLA-FLAVORED SOFT DRINKS, AND LEMONADE (U.S. CLS. 45, 46 AND 48).

CURTIS FRENCH, EXAMINING ATTORNEY

SN 79-090,370. MCAIRLAID'S VLIESTOFFE GMBH & CO. KG, FED REP GERMANY, FILED 11-5-2010.

Curea

THE MARK CONSISTS OF STANDARD CHARACTERS WITHOUT CLAIM TO ANY PARTICULAR FONT, STYLE, SIZE, OR COLOR.

PRIORITY DATE OF 5-10-2010 IS CLAIMED.

OWNER OF INTERNATIONAL REGISTRATION 1059548 DATED 11-5-2010, EXPIRES 11-5-2020.

THE WORDING "CUREA" HAS NO MEANING IN A FOREIGN LANGUAGE.

CLASS 5—PHARMACEUTICALS

FOR SANITARY PREPARATIONS FOR MEDICAL USE; PLASTERS FOR MEDICAL PURPOSES, MATERIALS FOR WOUND DRESSINGS, PHARMACEUTICAL WOUND TREATMENT PREPARATIONS, NAMELY, ABSORBENT AND IMPLANTABLE HAEMOSTATIC AGENTS AND PREPARATIONS; MEDICATED SKIN CARE PREPARATIONS FOR MEDICAL USE; PREPARATIONS FOR REMOVING PLASTERS AND MATERIALS FOR DRESSINGS AND RESIDUES THEREFROM, NAMELY, RUBBING ALCOHOL (U.S. CLS. 6, 18, 44, 46, 51 AND 52).

CLASS 10—MEDICAL APPARATUS

FOR SURGICAL AND MEDICAL INSTRUMENTS FOR USE IN SURGERY; SUTURE MATERIALS; DRAW-SHEETS FOR SICKBEDS; INCONTINENCE SHEETS; PADS FOR ABSORBING BODILY FLUIDS, NAMELY, INCONTINENCE PADS FOR PLACEMENT ON BEDS, CHAIRS AND SEATING (U.S. CLS. 26, 39 AND 44).

CLASS 27—FLOOR COVERINGS

FOR RUGS (U.S. CLS. 19, 20, 37, 42 AND 50).
DAVID HOFFMAN, EXAMINING ATTORNEY

SN 79-090,384. CACCIAMANI CLAUDIO, ITALY, FILED 3-30-2010.

CAFFE' DELLA SPOSA

THE MARK CONSISTS OF STANDARD CHARACTERS WITHOUT CLAIM TO ANY PARTICULAR FONT, STYLE, SIZE, OR COLOR.

PRIORITY DATE OF 12-23-2009 IS CLAIMED.

OWNER OF INTERNATIONAL REGISTRATION 1059590 DATED 3-30-2010, EXPIRES 3-30-2020.

NO CLAIM IS MADE TO THE EXCLUSIVE RIGHT TO USE "CAFFE'", APART FROM THE MARK AS SHOWN.

THE ENGLISH TRANSLATION OF "CAFFE' DELLA SPOSA" IN THE MARK IS THE BRIDE'S CAFE.

CLASS 30—STAPLE FOODS

FOR COFFEE; DECAFFEINATED COFFEE; INSTANT COFFEE; UNROASTED COFFEE; COFFEE BEANS; COFFEE ESSENCE; COFFEE FLAVOURINGS; COFFEE-BASED BEVERAGES; TEA; COCOA; SUGAR; RICE; TAPIOCA; SAGO; COFFEE SUBSTITUTES; TEA BASED BEVERAGES; CHOCOLATE BASED BEVERAGES CONTAINING MILK; FLOUR; PREPARATIONS MADE FROM CEREALS, BREAD, PASTRY AND CONFECTIONERY, NAMELY PASTIES AND DESSERTS; ICES; HONEY, TREACLE; YEAST, BAKING-POWDER; SALT, MUSTARD; VINEGAR, SAUCES; SPICES; ICE (U.S. CL. 46).

CLASS 43—HOTEL AND RESTAURANT SERVICES

FOR PROVIDING OF FOOD AND DRINK; BAR AND CAFETERIA SERVICES; CAFE SERVICES; RESTAURANT SERVICES AND CATERING; CAFETERIA SERVICES; PROVIDING ADVICE TO TOURISTS ON HOTEL AND RESTAURANT DESTINATIONS; PROVIDING TEMPORARY ACCOMMODATION; PROVIDING HOTEL ACCOMMODATION SERVICES; BOARDING HOUSES; TRAVEL AGENCY SERVICES, NAMELY, MAKING RESERVATIONS AND BOOKING FOR TEMPORARY HOTEL ACCOMMODATION AND RESTAURANTS; RENTAL OF ROOMS AS TEMPORARY LIVING ACCOMMODATIONS (U.S. CLS. 100 AND 101).

JOHN KELLY, EXAMINING ATTORNEY

CLASS 18—LEATHER GOODS

FOR LEATHER AND IMITATIONS OF LEATHER; GOODS MADE OF LEATHER AND IMITATIONS OF LEATHER, NAMELY, BAGS AND WALLETS, SUITCASES, LUGGAGE, GARMENT BAGS FOR TRAVEL, BRIEFCASES, KEY CASES, CREDIT CARD CASES, HANDBAGS, PURSES, SHOULDER BAGS, SPORTS BAGS, BACKPACKS, BEACH BAGS, ATTACHÉ CASES AND TOTE BAGS; TRUNKS AND TRAVELLING BAGS, UMBRELLAS, PARASOLS AND WALKING STICKS, WHIPS, HARNESSES AND SADDLERY (U.S. CLS. 1, 2, 3, 22 AND 41).

CLASS 29—MEATS AND PROCESSED FOODS

FOR OLIVE OIL FOR FOOD, PROCESSED OLIVES, EDIBLE OILS AND FATS, PRESERVED, FROZEN, DRIED AND COOKED FRUITS AND VEGETABLES, PREPARED NUTS, POTATO CHIPS, SESAME OIL, PEANUT BUTTER, HAZELNUT SPREAD (U.S. CL. 46).

CLASS 30—STAPLE FOODS

FOR BEVERAGES WITH COFFEE, COCOA OR CHOCOLATE BASE; COFFEE, BISCUITS, BREAD, CAKE ICING; CAKES, CANDY FOR FOOD, CHEWING GUM, NOT FOR MEDICAL PURPOSES, CHOCOLATE, COOKIES, CRACKERS, HONEY, ICED TEA, KETCHUP, PASTRY, SPICES; PRALINES (U.S. CL. 46).

SN 79-090,388, TURK HAVA YOLLARI ANONIM ORTAKLIĞI, TURKEY, FILED 8-4-2010.



OWNER OF INTERNATIONAL REGISTRATION 1059606 DATED 8-4-2010, EXPIRES 8-4-2020.

NO CLAIM IS MADE TO THE EXCLUSIVE RIGHT TO USE "FROM TURKEY", APART FROM THE MARK AS SHOWN.

THE COLOR(S) BLACK AND BEIGE IS/ARE CLAIMED AS A FEATURE OF THE MARK.

THE MARK CONSISTS OF A BLACK RECTANGLE WITH AN INSET BEIGE SINGLE LINE BORDER AND THE WORDING "WE'R FROM TURKEY" IN BEIGE IN THE LOWER HALF OF THE RECTANGLE.

CLASS 3—COSMETICS AND CLEANING PREPARATIONS

FOR SOAPS, NAMELY, HAND SOAP, SKIN SOAP, FACE SOAP, PERFUMED SOAP AND DEODORANT SOAP; PERFUMERY, COSMETICS AND DEODORANTS FOR PERSONAL USE (U.S. CLS. 1, 4, 6, 50, 51 AND 52).

CLASS 33—WINES AND SPIRITS

FOR ALCOHOLIC BEVERAGES EXCEPT BEERS (U.S. CLS. 47 AND 49).

CLASS 35—ADVERTISING AND BUSINESS

FOR ADVERTISING; BUSINESS MANAGEMENT; BUSINESS OPERATION, BUSINESS ADMINISTRATION AND OFFICE FUNCTIONS; BUSINESS MANAGEMENT CONSULTING AND ADVISORY SERVICES, NAMELY, THE PROVISION OF ASSISTANCE IN THE WORKING OR MANAGEMENT OF A COMMERCIAL UNDERTAKING OR PROVISION OF ASSISTANCE IN THE MANAGEMENT OF BUSINESS AFFAIRS OR COMMERCIAL FUNCTIONS OF AN INDUSTRIAL OR COMMERCIAL ENTERPRISE; THE BRINGING TOGETHER, FOR THE BENEFIT OF OTHERS, OF A VARIETY OF GOODS, EXCLUDING THE TRANSPORT THEREOF, ENABLING CUSTOMERS TO CONVENIENTLY VIEW AND PURCHASE THOSE GOODS IN THE FIELD OF FOOD, CANDY, GUM, SNACKS, BEVERAGES, NEWSPAPERS, MAGAZINES, BOOKS, DVDS, CDS, TOYS, GAMES, ALCOHOLIC BEVERAGES, WINE, TOBACCO PRODUCTS, PERFUME, CLOTHING, HATS, TIES, BELTS, GLOVES, SCARVES, SHOES, FOOTWEAR, BEACH TOWELS, BLANKETS, NECK RESTS, PILLOWS, PERSONAL CARE PRODUCTS AND TOILETRIES, UMBRELLAS, PICTURE FRAMES, PENS, PENCILS, STATIONARY, JEWELRY, WATCHES, SEWING KITS, ORNAMENTAL PINS AND BUTTONS, COSMETICS, OVER-THE-COUNTER MEDICATIONS, ELECTRONICS, HAND-HELD ELECTRONICS, POWER ADAPTERS AND CONVERTERS FOR ELECTRONIC APPARATUS, HEADPHONES, ELECTRONIC APPARATUS CABLES AND CONNECTORS, SPORTING GOODS, LEATHER GOODS AND BAGS, LUGGAGE, CARRY-ON BAGS, TOTE BAGS, ATTACHÉ CASES, LUGGAGE CARTS, LUGGAGE TAGS, KEY CHAINS, SUNGLASSES IN RETAIL STORES, WHOLESALE OUTLETS, ON BOARD AN AIRCRAFT OR FROM AN INTERNET WEB SITE PARTICULARLY SPECIALIZING IN THE MARKETING OF THE SALE OF GOODS AND SERVICES OF OTHERS (U.S. CLS. 100, 101 AND 102).

CLASS 39—TRANSPORTATION AND STORAGE

FOR DOMESTIC AND INTERNATIONAL AIR TRANSPORTATION SERVICES FOR THE CARRIAGE OF PASSENGERS, MAIL, FREIGHT AND CARGO; LAND TRANSPORTATION SERVICES BY RAIL, TRUCK AND CAR FOR THE CARRIAGE OF PASSENGERS, MAIL, FREIGHT AND CARGO; TRANSPORTATION AND TRAVEL RESERVATION SERVICES, NAMELY, TRAVEL BOOKING; TRAVEL RESERVATION SERVICES, TRAVEL, CARGO AND TOUR TICKET RESERVATION SERVICES AND TRANSPORT BROKERAGE SERVICES; WAREHOUSING SERVICES AND AIRCRAFT AND VEHICLE RENTAL AND CHARTERING SERVICES (U.S. CLS. 100 AND 105).

CLASS 41—EDUCATION AND ENTERTAINMENT

FOR ORGANIZING COMMUNITY SPORTING AND CULTURAL EVENTS; ARRANGING AND CONDUCTING ATHLETIC COMPETITIONS, PHOTOGRAPHY SERVICES; PRODUCTION OF FILM, RADIO AND TELEVISION PROGRAMS; ENTERTAINMENT IN THE NATURE OF ARRANGING AND CONDUCTING LIVE STAGE PERFORMANCES IN THE NATURE OF CONCERTS, MUSICAL CONCERTS, COMEDY SHOWS, PLAYS, THEATER PRODUCTIONS, BALLET PERFORMANCES, OPERAS PERFORMANCES, SPOKEN WORD PERFORMANCES AND ART EXHIBITIONS TO THE PUBLIC FOR CULTURAL OR EDUCATIONAL PURPOSES; PUBLICATION OF BOOKS, CATALOG AND JOURNALS (U.S. CLS. 100, 101 AND 107).

DAVID ELTON, EXAMINING ATTORNEY

SN 79-090,624. GLOBALANCE BANK AG, SWITZERLAND, FILED 11-5-2010.

Globalance Bank

THE MARK CONSISTS OF STANDARD CHARACTERS WITHOUT CLAIM TO ANY PARTICULAR FONT, STYLE, SIZE, OR COLOR.

PRIORITY DATE OF 9-1-2010 IS CLAIMED.
OWNER OF INTERNATIONAL REGISTRATION 1060151 DATED 11-5-2010, EXPIRES 11-5-2020.
NO CLAIM IS MADE TO THE EXCLUSIVE RIGHT TO USE "BANK", APART FROM THE MARK AS SHOWN.

CLASS 16—PAPER GOODS AND PRINTED MATTER

FOR PRINTED MATTER, NAMELY, BLANK FORMS FOR USE IN BANKING, PRINTED PUBLICATIONS, NAMELY, BOOKS, MAGAZINES, NEWSPAPERS, PAMPHLETS, LEAFLETS, BOOKLETS, PRINTED FORMS, NEWSLETTERS, CATALOGUES, PROSPECTUSES, REPORTS AND PERIODICALS ALL IN THE FIELD OF FINANCIAL SERVICES (U.S. CLS. 2, 5, 22, 23, 29, 37, 38 AND 50).

CLASS 35—ADVERTISING AND BUSINESS

FOR ADVERTISING SERVICES; BUSINESS MANAGEMENT; BUSINESS ADMINISTRATION; PROVIDING OFFICE FUNCTIONS (U.S. CLS. 100, 101 AND 102).

CLASS 36—INSURANCE AND FINANCIAL

FOR CONSULTING AND SERVICES IN THE FIELDS OF BANKING, MONETARY AFFAIRS AND FINANCIAL AFFAIRS, NAMELY, CAPITAL INVESTMENTS, FUND INVESTMENTS, WEALTH MANAGEMENT; AND REAL ESTATE AFFAIRS, NAMELY, APPRAISALS AND VALUATION, CONSULTANCY, BROKERAGE, FINANCIAL SERVICES (U.S. CLS. 100, 101 AND 102).

DAVID HOFFMAN, EXAMINING ATTORNEY

SN 79-090,687. ARLIGHT GENEL HIZMET TASARIM ELEKTROMEKANİK İMALAT TAAHHÜT SANAYİ VE TİCARİET LİMİTED SİRKETİ, ANKARA, TURKEY, FILED 4-20-2010.

ARLIGHT 

OWNER OF INTERNATIONAL REGISTRATION 1060278 DATED 4-20-2010, EXPIRES 4-20-2020.

THE COLOR(S) RED AND BLACK IS/ARE CLAIMED AS A FEATURE OF THE MARK.

THE MARK CONSISTS OF THE WORDING "ARLIGHT" IN STYLIZED BLACK TEXT AND A RED SQUARE WITH ROUNDED CORNERS HAVING AN UPTURNED LOWER LEFT CORNER IN THE COLOR BLACK.

CLASS 6—METAL GOODS

FOR NON-PRECIOUS METAL ORES; COMMON METALS AND THEIR ALLOYS; AND SEMI-MANUFACTURED PRODUCTS, NAMELY, ALUMINUM AND LEAD INGOTS, GALVANIZED STEEL SHEETS AND METAL WELDING RODS; METAL MATERIALS USED FOR CONSTRUCTION, NAMELY, BRACES, SUPPORTS AND SHORES; METAL MATERIALS USED FOR SHELTERING, SAVING, PROTECTING, COVERING, WRAPPING, SURROUNDING, STORING AND ESTABLISHING PURPOSE, NAMELY, METAL LADDERS, STORAGE SHELTERS AND SHEDS, ROOFING TILES AND PANELS, SAFES, AND ALUMINUM FOIL; METAL MATERIALS USED FOR SIFTING, FILTERING AND SIMILAR PURPOSES, NAMELY, WIRE MESH; METAL DOORS AND WINDOWS; METAL SHUTTERS FOR WINDOWS AND BUILDING EXTERIORS; JALOUSIES OF METAL, CASES IN THE NATURE OF METAL FRAMES FOR JALOUSIES AND METAL HANDLES THEREOF, EXCLUDING LOCKS; METAL CABLES AND WIRES NOT FOR ELECTRICAL PURPOSES; IRONMONGERY, IRON GATES, PELLETIZED IRON AND WROUGHT IRON DECORATIVE ARTWORK; SMALL ITEMS OF METAL HARDWARE, NAMELY, SCREWS, NAILS, RIVETS, AND SPRINGS; AIR CONDITIONING DUCTS OF METAL; METAL PIPES; CHIMNEY HEADS FOR USE WITH VENTILATING, HEATING AND AIR CONDITIONING INSTALLATIONS, NAMELY, METAL CHIMNEY CAPS; NON-LUMINOUS AND NON-MECHANICAL METAL SIGNS FOR INDICATION AND ADVERTISING PURPOSES, NAMELY, SIGNBOARDS, PANELS, REGISTRATION PLATES; METAL PIPES FOR LIQUID AND GAS TRANSFER AND CONNECTING PARTS THEREOF, NAMELY, DRILLING PIPES; METAL MONEY SAFES; RAILWAY MATERIALS MADE OF METAL, NAMELY, RAILROAD TIES AND TRACKS; METAL CROWN POSTS AND FLOATS, NAMELY, METAL CROWN POSTS FOR BUILDING AND METAL FENCE POSTS; BUOYS OF METAL; ANCHORS FOR SEA VEHICLES; METAL MOULDS FOR CASTING EXCEPT FOR MACHINE PARTS; WORKS OF ART MADE OF COMMON METALS AND OF THEIR ALLOYS; METAL COVERS, NAMELY, MANHOLE COVERS AND METAL VENT COVERS FOR HVAC DUCTS; METAL BOTTLE CAPS; METAL POLES; METAL PALLETS FOR LIFTING, LOADING AND TRANSPORTING; METAL ROPES; METAL HOOKS CORDS, COLUMNS, BRACES, BANDS AND STRAPS FOR LIFTING AND TRANSPORTING OF LOADS AND CARGOS IN THE NATURE OF CONSTRUCTION ELEMENTS AND HARDWARE (U.S. CLS. 2, 12, 13, 14, 23, 25 AND 50).

CLASS 9—ELECTRICAL AND SCIENTIFIC APPARATUS

FOR APPARATUS AND INSTRUMENTS USED FOR MEASUREMENT AND ESTIMATION IN SCIENTIFIC LABORATORIES, NAMELY, MEASURING LASERS, CLINICAL LABORATORY ANALYZER FOR BLOOD AND OTHER BODILY FLUIDS, AND SPECTROSCOPES; APPARATUS FOR RECORDING, TRANSMISSION OR REPRODUCTION OF SOUND AND IMAGES, NAMELY, APPARATUS, HARDWARE, SOFTWARE AND PERIPHERALS FOR DATA PROCESSING, COMMUNICATION AND REPRODUCTION; RECORD CARRIERS IN THE FORM FOR MAGNETIC, OPTIC OR EXPOSED FILM, NAMELY, EXPOSED PHOTOGRAPHIC AND X-RAY FILM, PRE-RECORDED OPTICAL AND MAGNETIC DISCS FEATURING MUSIC, AND BLANK MAGNETIC DISCS; ANTENNAS; SATELLITE ANTENNAS; AMPLIFIERS AND PARTS THEREOF; AUTOMATIC VENDING MACHINES; AUTOMATIC TICKET DISPENSERS; CASH MACHINES, NAMELY, CASH REGISTERS AND AUTOMATED TELLER MACHINES; ELECTRONIC ELEMENTS USED IN ELECTRONIC APPARATUS, NAMELY, CIRCUITS AND POWER CABLES AND ADAPTORS; COUNTERS FOR MEASURING THE CONSUMPTION OF THE UNIT OF TIME, NAMELY, HOURGLASS, ELECTRONIC TIMER; TIMERS; PROTECTIVE CLOTHING, NAMELY, DISPOSABLE GARMENT FOR PROTECTION AGAINST SPONTANEOUS FLASH IN INDUSTRIAL AND MANUFACTURING ENVIRONMENTS, CLOTHING ESPECIALLY MADE FOR USE IN LABORATORIES, PADDED CLOTHING FOR PROTECTION AGAINST BODILY HARM AND BLUNT FORCE TRAUMA, CLOTHING FOR PROTECTION AGAINST FIRE, IRRADIATION AND ACCIDENTS; LIFE SAVING AND PROTECTING EQUIPMENT, NAMELY, LIFE JACKETS, FIRE RESISTANT GLOVES, BULLET-PROOF VESTS; GLASSES, NAMELY, EYEGLASSES AND OPTICAL GLASSES; SUN GLASSES; LENSES AND THEIR BOXES, CASES, PARTS AND ACCESSORIES, NAMELY, LENSES FOR CAMERAS, CASES AND BOXES SPECIALLY ADAPTED FOR CARRYING CAMERA LENS, AND ACCESSORIES AND PARTS FOR CAMERA LENSES IN THE NATURE OF LENS FILTERS AND HOODS; APPARATUS FOR TRANSMISSION, TRANSDUCTION, STORAGE AND CONTROL OF ELECTRIC ENERGY, NAMELY, CABLES AND POWER SUPPLY USED IN ELECTRIC AND ELECTRONICS; ALARM APPARATUS, EXCEPT VEHICLE ALARMS, NAMELY, BURGLAR ALARMS, PERSONAL SECURITY ALARMS, SOUND ALARMS, SMOKE ALARMS AND FIRE ALARMS; ELECTRICAL BELLS, NAMELY, ELECTRIC DOOR BELLS, CALL BELLS, ELECTRONIC WARNING BELLS AND SIGNAL BELLS; IRONS, NAMELY, ELECTRIC IRONS; ELECTRICAL AND STEAM IRONS; PRESS IRONS, NAMELY, ELECTRIC PRESS IRONS; SIGNALING APPARATUS, NAMELY, SIGNAL BELLS, SIGNAL WHISTLES, AND TRAFFIC LIGHTS; INDICATORS USED FOR TRAFFIC PURPOSES, NAMELY, TRAFFIC LIGHTS, REFLECTORS FOR TRAFFIC SIGNALS, VEHICLE TRAFFIC SIGNALS, AND SAFETY TRAFFIC CONES; FIRE ENGINES; FIRE-EXTINGUISHING APPARATUS AND DEVICES; ELECTRICAL WELDING APPARATUS, NAMELY, WELDING ELECTRODES; RADARS; SUBMARINE RADARS, NAMELY, SONAR; NIGHT VISION APPARATUS AND DEVICES, NAMELY, NIGHT VISION GOGGLES; ELECTRIC DEVICES FOR DESTROYING FLIES AND INSECTS; AUTOMATIC DOORS, NAMELY, ELECTRONIC DOOR OPENERS AND CLOSERS, ELECTRIC DOOR OPENERS AND CLOSERS, OR ELECTRONIC DOOR OPENING AND CLOSING SYSTEM; AUTOMATIC TURNSTILES; ELECTRIC, ELECTRONIC AND REMOTE CONTROL DOOR OPENING-CLOSING INSTALLATIONS FOR BUILDINGS; APPARATUS FOR ELECTROLYSIS AND GALVANIZATION FOR USE IN ELECTROPLATING; ANODES; CATHODES; MAGNETS; DECORATIVE MAGNETS (U.S. CLS. 21, 23, 26, 36 AND 38).

CLASS 10—MEDICAL APPARATUS

FOR SURGICAL, MEDICAL, DENTAL AND VETERINARY APPARATUS, NAMELY, SURGICAL BLADES AND RETRACTORS, MEDICAL INSTRUMENTS FOR PERFORMING BIOPSIES, DENTAL DRILLS AND MIRRORS, AND VETERINARY SURGICAL KNIVES AND EXAMINATION GLOVES; DEVICES AND FURNITURE ESPECIALLY MADE FOR MEDICAL PURPOSES, NAMELY, MEDICAL PATIENT TREATMENT CHAIRS, MEDICAL LASERS, AND OPERATING TABLES; ARTIFICIAL LIMBS AND ORGANS; MEDICAL ORTHOPEDIC MATERIALS, NAMELY, BRACES, SUPPORTS, BELTS, CUSHIONS, JOINT IMPLANTS, FOOTWEAR, SOLES, AND SPLINTS; CLOTHING FOR SURGERY ROOMS, NAMELY, GOWNS, CAPS, SURGICAL MASKS, AND SHOE COVERS; STERILE COVERS, NAMELY, SURGICAL DRAPES AND COVERINGS FOR MEDICAL EXAM TABLES; APPARATUS AND MATERIALS FOR SEXUAL PURPOSES, NAMELY, SEX DOLLS, VIBRATORS, AND CONDOMS; BIRTH CONTROL INSTRUMENTS, NAMELY, CONDOM; FEEDING BOTTLES; FEEDING BOTTLE NIPPLES; PACIFIERS; TEETHING RINGS (U.S. CLS. 26, 39 AND 44).

CLASS 11—ENVIRONMENTAL CONTROL APPARATUS

FOR LIGHTING APPARATUS, NAMELY, LAMPS, FLASHLIGHTS, LIGHTING INSTALLATIONS, VEHICLE HEADLIGHTS, TAIL LIGHTS, BACK UP LIGHTS, TURN SIGNAL LIGHT BULBS, AND LIGHT BULBS FOR THE INTERIOR OF VEHICLES; APPARATUS FOR HEATING AND STEAM PRODUCING INSTALLATIONS, NAMELY, SOLID, LIQUID OIL AND GAS FUEL AND ELECTRIC STOVES, ELECTRIC COOK STOVES; AIR-CONDITIONING DEVICES, AND CLIMATIZATION DEVICES, NAMELY, CLIMATE CONTROL DEFROSTERS, AIR CONDITIONERS, ELECTRIC HEATERS FOR COMMERCIAL USE, AND HEATERS FOR VEHICLES; COOLING APPARATUS, NAMELY, COOLING EVAPORATORS, REFRIGERATORS; FREEZERS; ELECTRIC AND GAS APPARATUS, NAMELY, ELECTRIC STOVES, GAS STOVES, ELECTRIC OVENS, GAS COOKING OVENS FOR HOUSEHOLD PURPOSES, AND COOKTOPS, GAS GRILLS AND RANGES; MACHINES AND DEVICES USED FOR COOKING, DRYING AND BOILING, EXCLUDING USE FOR PERSONAL PURPOSES, NAMELY, COMMERCIAL COOKING OVENS, INDUSTRIAL DRYERS FOR HEATING AND DEHUMIDIFYING, AND INDUSTRIAL BOILERS; SANITARY APPARATUS AND INSTALLATIONS, NAMELY, BATHTUBS, SHOWERS, SINKS, ELECTRIC HAND DRYING APPARATUS FOR WASHROOMS, AND TOILETS; WATER SOFTENING APPARATUS; WATER PURIFYING APPARATUS; WATER PURIFYING INSTALLATIONS; SEWAGE PURIFYING INSTALLATIONS; APPARATUS FOR BEAUTY SALON PURPOSES IN THIS CLASS, NAMELY, HAND DRYING MACHINES, NAIL DRYING MACHINES, HAIR DRYING MACHINES, AND HAIR STEAMER MACHINES; ELECTRICAL COVERLETS AND ELECTRICAL QUILTS NOT FOR MEDICAL PURPOSES; HEATING PILLOWS, NAMELY, ELECTRIC HEATED PILLOWS NOT FOR MEDICAL PURPOSES; ELECTRICAL FOOT HEATERS; HOT WATER BOTTLES; FILTERS AND FILTER-MOTOR COMBINATIONS FOR AQUARIUMS; PASTEURIZING AND STERILIZING MACHINES FOR USE IN THE FOOD AND BEVERAGE INDUSTRY; INDUSTRIAL TYPE COOKING, DRYING AND COOLING INSTALLATIONS, NAMELY, COOKING OVENS, CLOTHING DRYERS, AND WALK-IN COOLERS (U.S. CLS. 13, 21, 23, 31 AND 34).

CLASS 19—NON-METALLIC BUILDING MATERIALS

FOR STYLIZED BUILDING, CONSTRUCTION, AND ROAD CONSTRUCTION MATERIALS MADE OF CONCRETE, GYPSUM, EARTH, CLAY, SAND, NATURAL STONE, ARTIFICIAL STONE, WOODEN, PLASTIC OR SYNTHETIC MATERIALS, NAMELY, CONCRETE PAVING STONES, BLOCK AND TILES, GYPSUM TILES, EARTHENWARE PIPES, CLAY ROOFING TILES, SANDSTONE PIPES, NATURAL STONE SLABS AND TILES, ARTIFICIAL STONE TILES, WOOD MOLDINGS, POSTS AND TRIM, PLASTIC WALLBOARDS AND FLOORBOARDS, AND SYNTHETIC COUNTERTOPS FOR FURTHER INSTALLATION; BUILDING PARTS, NAMELY, WOOD BOARDS, CONCRETE BLOCKS AND SLABS, NON-METAL BUILDING FLASHING, AND GLASS PANELS FOR BUILDING CONSTRUCTION; BUILDINGS, NAMELY, NON-METAL STORAGE SHEDS, PREFABRICATED NON-METAL BUILDINGS; POLES, NAMELY, WOODEN UTILITY POLES, NON-METAL UTILITY POLES, AND NON-METAL FENCE POLES; BARRIERS, NAMELY, PORTABLE NON-METAL TRAFFIC BARRIERS, CRASH BARRIERS NOT OF METAL, NOISE BARRIERS MADE OF WOOD, PORTABLE NON-METAL FREE STANDING BARRIERS, NON-METAL BARRIERS FOR PEDESTRIAN TRAFFIC CONTROL, NON-METAL FENCING IN THE NATURE OF AN INDUSTRIAL SAFETY BARRIER, PLASTIC REINFORCED WALL PANELS FOR USE AS SOUND AND LIGHT BARRIERS; MONUMENTS OF STONE, CONCRETE AND MARBLE; STATUES MADE OF CONCRETE STONE AND MARBLE; NATURAL OR SYNTHETIC SURFACE COVERINGS IN FORM OF LAYERS OR BANDS, NAMELY, NON-METAL COVERINGS FOR CEILINGS, MULTIPLE LAYER DRYWALL; SYNTHETIC COATINGS MADE ADHERED THROUGH HEAT, NAMELY, BITUMINOUS ROOF COATINGS; PITCHY CARDBOARD FOR ROOFS, NAMELY, ROOFING UNDERLAYMENT; PITCHY COVERINGS, NAMELY, NON-METAL ROOFING TILES, NON-METAL FLOORING UNDERLAYMENTS; GLASS PRODUCTS FOR CONSTRUCTIONS, NAMELY, GLASS ROOFING TILES AND WINDOW GLASS; NON-METAL PREFABRICATED SWIMMING POOLS; AQUARIUM SANDS (U.S. CLS. 1, 12, 33 AND 50).

CLASS 35—ADVERTISING AND BUSINESS

FOR ADVERTISING, MARKETING AND PUBLIC RELATIONS SERVICES, AND ORGANIZATION OF EXHIBITIONS AND FAIRS FOR TRADE PURPOSES; OFFICE SERVICES, NAMELY, OFFICE SUPPORT STAFF SERVICES AND OFFICE ADMINISTRATION SERVICES; BUSINESS ADMINISTRATION, MANAGEMENT AND ACCOUNTING, AND CONSULTANCY IN THE FIELDS OF BUSINESS ADMINISTRATION, MANAGEMENT, AND ACCOUNTING, AND IMPORT-EXPORT AGENCY SERVICES; ARRANGING OF CONTRACTS FOR OTHERS FOR THE BUYING AND SELLING OF GOODS; ORGANIZATION AND ARRANGEMENT OF PUBLIC AUCTIONS; BRINGING TOGETHER FOR THE BENEFIT OF OTHERS, OF A VARIETY OF GOODS ENABLING CUSTOMERS TO CONVENIENTLY VIEW AND PURCHASE THOSE GOODS, NAMELY, RETAIL AND WHOLESALE STORE SERVICES, ONLINE RETAIL STORE SERVICES, AND ELECTRONIC AND MAIL ORDER CATALOG SERVICES ALL FEATURING BUILDING AND CONSTRUCTION MATERIALS, LIGHTING AND HEATING EQUIPMENT, AND AUTOMOTIVE ACCESSORIES (U.S. CLS. 100, 101 AND 102).
APRIL ROACH, EXAMINING ATTORNEY

SN 79-090,850. TURK HAVA YOLLARI ANONIM ORTAKLIĞI, TURKEY, FILED 8-4-2010.

THE MARK CONSISTS OF STANDARD CHARACTERS WITHOUT CLAIM TO ANY PARTICULAR FONT, STYLE, SIZE, OR COLOR.

OWNER OF INTERNATIONAL REGISTRATION 1060697 DATED 8-4-2010, EXPIRES 8-4-2020.

CLASS 3—COSMETICS AND CLEANING PREPARATIONS

FOR SOAPS, NAMELY, HAND SOAP, SKIN SOAP, FACE SOAP, PERFUMED SOAP AND DEODORANT SOAP; PERFUMERY, COSMETICS AND DEODORANTS FOR PERSONAL USE (U.S. CLS. 1, 4, 6, 50, 51 AND 52).

CLASS 18—LEATHER GOODS

FOR LEATHER AND IMITATIONS OF LEATHER; GOODS MADE OF LEATHER AND IMITATIONS OF LEATHER, NAMELY, BAGS AND WALLETS, SUITCASES, LUGGAGE, GARMENT BAGS, BRIEFCASES, KEY CASES, CREDIT CARD CASES, HANDBAGS, PURSES, SHOULDER BAGS, SPORTS BAGS, BACKPACKS, BEACH BAGS, ATTACHE CASES AND TOTE BAGS; TRUNKS AND TRAVELLING BAGS, UMBRELLAS, PARASOLS AND WALKING STICKS, WHIPS, HARNESSES AND SADDLERY (U.S. CLS. 1, 2, 3, 22 AND 41).

CLASS 29—MEATS AND PROCESSED FOODS

FOR OLIVE OIL FOR FOOD, PROCESSED OLIVES, EDIBLE OILS AND FATS, PRESERVED, FROZEN, DRIED AND COOKED FRUITS AND VEGETABLES, PREPARED NUTS, POTATO CHIPS, SESAME OIL, PEANUT BUTTER, HAZELNUT SPREAD (U.S. CL. 46).

CLASS 30—STAPLE FOODS

FOR BEVERAGES WITH COFFEE, COCOA OR CHOCOLATE BASE; COFFEE, BISCUITS, BREAD, CAKE ICING; CAKES, CANDY FOR FOOD, CHEWING GUM, NOT FOR MEDICAL PURPOSES, CHOCOLATE, COOKIES, CRACKERS, HONEY, ICED TEA, KETCHUP, PASTRY, SPICES; PRALINES (U.S. CL. 46).

CLASS 33—WINES AND SPIRITS

FOR ALCOHOLIC BEVERAGES EXCEPT BEERS (U.S. CLS. 47 AND 49).

CLASS 35—ADVERTISING AND BUSINESS

FOR ADVERTISING; BUSINESS MANAGEMENT; BUSINESS OPERATION, BUSINESS ADMINISTRATION AND OFFICE FUNCTIONS; BUSINESS MANAGEMENT CONSULTING AND ADVISORY SERVICES, NAMELY, THE PROVISION OF ASSISTANCE IN THE WORKING OR MANAGEMENT OF A COMMERCIAL UNDERTAKING OR PROVISION OF ASSISTANCE IN THE MANAGEMENT OF BUSINESS AFFAIRS OR COMMERCIAL FUNCTIONS OF AN INDUSTRIAL OR COMMERCIAL ENTERPRISE; THE BRINGING TOGETHER, FOR THE BENEFIT OF OTHERS, OF A VARIETY OF GOODS, EXCLUDING THE TRANSPORT THEREOF, ENABLING CUSTOMERS TO CONVENIENTLY VIEW AND PURCHASE THOSE GOODS IN THE FIELD OF FOOD, CANDY, GUM, SNACKS, BEVERAGES, NEWSPAPERS, MAGAZINES, BOOKS, DVDS, CDS, TOYS, GAMES, ALCOHOLIC BEVERAGES, WINE, TOBACCO PRODUCTS, PERFUME, CLOTHING, HATS, TIES, BELTS, GLOVES, SCARVES, SHOES, FOOTWEAR, BEACH TOWELS, BLANKETS, NECK RESTS, PILLOWS, PERSONAL CARE PRODUCTS AND TOILETRIES, UMBRELLAS, PICTURE FRAMES, PENS, PENCILS, STATIONARY, JEWELRY, WATCHES, SEWING KITS, ORNAMENTAL PINS AND BUTTONS, COSMETICS, OVER-THE-COUNTER MEDICATIONS, ELECTRONICS, HAND-HELD ELECTRONICS, POWER ADAPTERS AND CONVERTERS FOR ELECTRONIC APPARATUS, HEADPHONES, ELECTRONIC APPARATUS CABLES AND CONNECTORS, SPORTING GOODS, LEATHER GOODS AND BAGS, LUGGAGE, CARRY-ON BAGS, TOTE BAGS, ATTACHÉ CASES, LUGGAGE CARTS, LUGGAGE TAGS, KEY CHAINS, SUNGLASSES IN RETAIL STORES, WHOLESALE OUTLETS, ON BOARD AN AIRCRAFT OR FROM AN INTERNET WEB SITE PARTICULARLY SPECIALIZING IN THE MARKETING OF THE SALE OF GOODS AND SERVICES OF OTHERS (U.S. CLS. 100, 101 AND 102).

CLASS 39—TRANSPORTATION AND STORAGE

FOR DOMESTIC AND INTERNATIONAL AIR TRANSPORTATION SERVICES FOR THE CARRIAGE OF PASSENGERS, MAIL, FREIGHT AND CARGO; LAND TRANSPORTATION SERVICES BY RAIL, TRUCK AND CAR FOR THE CARRIAGE OF PASSENGERS, MAIL, FREIGHT AND CARGO; TRANSPORTATION AND TRAVEL RESERVATION SERVICES, NAMELY, TRAVEL BOOKING; TRAVEL RESERVATION SERVICES, TRAVEL, CARGO AND TOUR TICKET RESERVATION SERVICES AND TRANSPORT BROKERAGE SERVICES; WAREHOUSING SERVICES AND AIRCRAFT AND VEHICLE RENTAL AND CHARTERING SERVICES (U.S. CLS. 100 AND 105).

CLASS 41—EDUCATION AND ENTERTAINMENT

FOR ORGANIZING COMMUNITY SPORTING AND CULTURAL EVENTS; ARRANGING AND CONDUCTING ATHLETIC COMPETITIONS, PHOTOGRAPHY SERVICES; PRODUCTION OF FILM, RADIO AND TELEVISION PROGRAMS; ENTERTAINMENT IN THE NATURE OF ARRANGING AND CONDUCTING LIVE STAGE PERFORMANCES IN THE NATURE OF CONCERTS, MUSICAL CONCERTS, COMEDY SHOWS, PLAYS, THEATER PRODUCTIONS, BALLET PERFORMANCES, OPERAS PERFORMANCES, SPOKEN WORD PERFORMANCES AND ART EXHIBITIONS TO THE PUBLIC FOR CULTURAL OR EDUCATIONAL PURPOSES; PUBLICATION OF BOOKS, CATALOG AND JOURNALS (U.S. CLS. 100, 101 AND 107).

ELIZABETH KAJUBI, EXAMINING ATTORNEY

SN 79-090,880, YOUR BRELLATOPPER DESIGN GMBH, FED REP GERMANY, FILED 9-24-2010.

brellatopper

THE MARK CONSISTS OF STANDARD CHARACTERS WITHOUT CLAIM TO ANY PARTICULAR FONT, STYLE, SIZE, OR COLOR.

PRIORITY DATE OF 3-26-2010 IS CLAIMED.

OWNER OF INTERNATIONAL REGISTRATION 1060760 DATED 9-24-2010, EXPIRES 9-24-2020.

CLASS 18—LEATHER GOODS

FOR SHEATHS FOR STATIONARY SUNSHADES (U.S. CLS. 1, 2, 3, 22 AND 41).

CLASS 22—CORDAGE AND FIBERS

FOR TEXTILE POUCHES IN THE NATURE OF SLEEVES AND BAGS FOR PACKAGING (U.S. CLS. 1, 2, 7, 19, 22, 42 AND 50).

CLASS 24—FABRICS

FOR UNFITTED TEXTILE COVERINGS FOR STATIONARY SHADES AND FLAGPOLES (U.S. CLS. 42 AND 50).

PATRICIA EVANKO, EXAMINING ATTORNEY

SN 79-091,004, WATATAWA INVESTMENTS PTE. LTD., SINGAPORE 427817, SINGAPORE, FILED 11-8-2010.

WATATAWA

THE MARK CONSISTS OF STANDARD CHARACTERS WITHOUT CLAIM TO ANY PARTICULAR FONT, STYLE, SIZE, OR COLOR.

PRIORITY DATE OF 7-20-2010 IS CLAIMED.

OWNER OF INTERNATIONAL REGISTRATION 1061117 DATED 11-8-2010, EXPIRES 11-8-2020.

THE WORDING "WATATAWA" HAS NO MEANING IN A FOREIGN LANGUAGE.

CLASS 35—ADVERTISING AND BUSINESS

FOR ADVERTISING; BUSINESS MANAGEMENT; BUSINESS ADMINISTRATION; PROVIDING OFFICE FUNCTIONS; STRATEGIC BUSINESS PLANNING AND CONSULTANCY; CONDUCTING OF BUSINESS RESEARCH; MARKETING AND BUSINESS COMMUNICATIONS STRATEGY CONSULTING; BUSINESS ADVISORY SERVICES; BUSINESS ADVICE RELATING TO COMMUNICATIONS AND MARKETING; PLANNING OF MARKETING STRATEGIES; PROVISION OF BUSINESS ASSISTANCE RELATING TO THE ARRANGEMENT OF JOINT VENTURES; PROVISION OF BUSINESS INFORMATION RELATING TO JOINT VENTURES; BUSINESS MEETING PLANNING (U.S. CLS. 100, 101 AND 102).

CLASS 36—INSURANCE AND FINANCIAL

FOR INSURANCE BROKERAGE; FINANCIAL AFFAIRS AND MONETARY AFFAIRS, NAMELY, FINANCIAL INFORMATION, MANAGEMENT AND ANALYSIS SERVICES; REAL ESTATE BROKERAGE; BUSINESS INVESTMENT BANKING SERVICES; CONSULTANCY SERVICES RELATING TO FINANCIAL INVESTMENTS; FINANCIAL AND INVESTMENT MANAGEMENT SERVICES; VENTURE CAPITAL ADVISORY SERVICES, NAMELY, FINANCIAL SERVICES FOR THE FINDING OF VENTURE CAPITAL AND PRIVATE EQUITY; VENTURE CAPITAL FUND MANAGEMENT (U.S. CLS. 100, 101 AND 102).

KELLY TRUSILO, EXAMINING ATTORNEY

CLASS 25—CLOTHING

FOR CLOTHING ITEMS, NAMELY, SWEATERS, CARDIGANS, SLIPOVERS, SUITS, TROUSERS, SHORTS, JUMPERS, RAINCOATS, SUITS AND DRESSES MADE OF LEATHER, STOCKINGS AND SOCKS, GARTER BELTS, WIND RESISTANT JACKETS, SKI-TROUSERS, FUR COATS, OVERCOATS, JACKETS, SKIRTS, DRESSES, UNDERSHIRTS, T-SHIRTS, SPORT T-SHIRTS, BLOUSES, SHIRT-COLLARS, SHIRTS, FOULARDS, BEACHWEAR, SWIMSUITS, BIKINI, TRACKSUITS, UNDERWEAR, LINGERIE, BATHROBES, BRAS, BRASSIERE, CORSETS, FOUNDATION SLIPS, BRIEFS AND BIKINI BRIEFS, VESTS, NIGHTGOWNS, NEGLIGEEES, PYJAMAS, GLOVES, SHAWLS, SCARVES, NECKTIES, BOW TIES, BELTS USED AS CLOTHING, SUSPENDERS; HATS AND CAPS; SHOES, BOOTS, LACED BOOTS, LEATHER SHOES, RUBBER SHOES, RAIN SHOES, SPORT SHOES, SANDALS, SLIPPERS, SHOE SOLES, SHOES HEELS, MOULDED SOLES FOR SHOES (U.S. CLS. 22 AND 39).

APRIL ROACH, EXAMINING ATTORNEY

SN 79-091,098. ARNALDO CAPRAI GRUPPO TESSILE SPA, ITALY, FILED 8-4-2010.



Arnaldo Caprai

...orgogliosamente Made in Italy

OWNER OF INTERNATIONAL REGISTRATION 0947325 DATED 11-8-2007, EXPIRES 11-8-2017.

NO CLAIM IS MADE TO THE EXCLUSIVE RIGHT TO USE "MADE IN ITALY", APART FROM THE MARK AS SHOWN.

THE NAME(S), PORTRAIT(S), AND/OR SIGNATURE(S) SHOWN IN THE MARK IDENTIFIES "ARNALDO CAPRAI", WHOSE CONSENT(S) TO REGISTER IS MADE OF RECORD.

THE MARK CONSISTS OF "...ORGOGLIOSAMENTE MADE IN ITALY" UNDER THE NAME AND SURNAME "ARNALDO CAPRAI" COMBINED WITH THE MONOGRAM "AC" WHERE THE INITIALS ARE CHAINED TO EACH OTHER, DRAFTED ON A SQUARE BACKGROUND FEATURING A FLOWER-LIKE EMBROIDERY.

THE ENGLISH TRANSLATION OF "ORGAGLIOSAMENTE" IN THE MARK IS "PROUDLY".

CLASS 24—FABRICS

FOR FABRICS, NAMELY, FABRICS FOR TEXTILE USE, FABRICS FOR USE IN THE MANUFACTURE OF CLOTHING AND HOUSEHOLD LINEN, SILK FABRICS, CASHMERE FABRIC, CHENILLE FABRIC, CHIFFON FABRIC, COTTON FABRIC, LINEN FABRIC, POLYESTER FABRIC, WOOL YARN FABRIC, JEANS FABRIC, JERSEY FABRIC FOR CLOTHING, JUTE FABRICS; TABLE COVERS, NAMELY, TABLE CLOTHS OF TEXTILE, PLASTIC TABLE COVERS, TABLE MATS NOT OF PAPER, PLACE MATS OF TEXTILE MATERIAL, CLOTH COASTERS, CLOTH DOILIES, DECORATIVE CENTERPIECES MADE OF FABRIC BEING CLOTH BUNTING AND CLOTH TABLE TOPPERS; NAPKINS, NAMELY, TEXTILE NAPKINS; BED SHEETS; PILLOWCASES; BED LINENS IN THE NATURE OF BLANKETS, NAMELY, BEDSPREADS, QUILTS, BED BLANKETS, COTTON BLANKETS, POLYESTER BLANKETS, WOOLEN BLANKETS, SILK BLANKETS, CASHMERE BLANKETS, BLANKET TROWS; BED COVERS; TOWELS; BATH CLOTHS, NAMELY, BATH TOWELS AND WASH-CLOTHS (U.S. CLS. 42 AND 50).

SN 79-091,110. KITARO TEXTILHANDEL GMBH, FED REP GERMANY, FILED 8-26-2010.

ARQUEONAUTAS

OWNER OF INTERNATIONAL REGISTRATION 1018737 DATED 7-14-2009, EXPIRES 7-14-2019.

OWNER OF U.S. REG. NO. 3,658,260.

THE MARK CONSISTS OF THE WORD "ARQUEONAUTAS" IN STYLIZED FORM.

THE WORDING "ARQUEONAUTAS" HAS NO MEANING IN A FOREIGN LANGUAGE.

CLASS 9—ELECTRICAL AND SCIENTIFIC APPARATUS

FOR SPECTACLES; SUNGLASSES; SPECTACLE CASES; SPECTACLE FRAMES; SPECTACLE LENSES; DIVING SUITS; DIVING APPARATUS, NAMELY, DIVING HELMETS, DIVING GOGGLES AND REGULATORS FOR USE IN SCUBA DIVING; GLOVES FOR DIVERS; DIVING MASKS; BREATHING APPARATUS FOR DIVERS, NAMELY, REBREATHERS, COMPRESSED AIR BAILOUT UNITS, BUOYANCY BLADDERS AND SODA LIME CARTRIDGES; RECORDING AND PLAYING DEVICES FOR SOUND AND FILM IMAGE CARRIERS; BLANK RECORDABLE OPTICAL DISCS; PRE-RECORDED CDS AND DVDS FEATURING MUSIC AND MOTION PICTURE FILMS ABOUT SCUBA DIVING INSTRUCTION; COMPACT DISCS FEATURING SCUBA DIVING INSTRUCTIONS; BLANK CD-ROMS AND DVD-ROMS FOR SOUND OR VIDEO RECORDING; BLANK VIDEO TAPES AND VIDEO CASSETTES; PRE-RECORDED VIDEOTAPES AND VIDEO CASSETTES FEATURING MUSIC AND SCUBA DIVING INSTRUCTIONS; EXPOSED PHOTOGRAPHIC FILMS; BINOCULARS; TELESCOPES; WATER WING SWIM FLOATS FOR SAFETY PURPOSES; SWIMMING BELTS FOR USE AS SWIM FLOATS FOR SAFETY PURPOSES; SWIMMING LIFE JACKETS AND SWIMMING BUOYANCY COMPENSATOR JACKETS FOR USE IN SCUBA DIVING (U.S. CLS. 21, 23, 26, 36 AND 38).

CLASS 14—JEWELRY

FOR JEWELLERY; HOROLOGICAL AND CHRONOMETRIC INSTRUMENTS; WRIST WATCHES; STRAPS FOR WRIST WATCHES; NECKLACES; CUFF LINKS; TIE PINS; EARRINGS; RINGS; ORNAMENTAL PINS (U.S. CLS. 2, 27, 28 AND 50).

CLASS 18—LEATHER GOODS

FOR LEATHER AND IMITATION LEATHER AND GOODS MADE OF THESE MATERIALS AND NOT INCLUDED IN OTHER CLASSES, NAMELY, TRUNKS AND TRAVELLING BAGS, KEY CASES OF LEATHER, COLLARS FOR ANIMALS, HARNESS FOR ANIMALS, RIDING SADDLES AND BRIEFCASES; PLASTIC TRUNKS; CANVAS TRAVELING BAGS; VANITY CASES SOLD EMPTY; PURSES NOT OF PRECIOUS METAL; BEACH BAGS; BRIEFCASES; POCKET WALLETS; CAMPING BAGS, NAMELY, ALL-PURPOSE CARRYING BAGS, BUM BAGS AND BACKPACKS; HANDBAGS; CANVAS, LEATHER AND REUSABLE SHOPPING BAGS; UNFITTED VANITY CASES; BANDS OF LEATHER; RUCKSACKS; TRAVELLING BAGS; SCHOOL BAGS; SHOE BAGS FOR TRAVEL; HORSE BLANKETS; UMBRELLAS, PARASOLS AND WALKING STICKS (U.S. CLS. 1, 2, 3, 22 AND 41).

DAVID YONTEF, EXAMINING ATTORNEY

SN 79-091,132. KOMBIMATIC AS, NORWAY, FILED 10-6-2010.

KOMBIMATIC

THE MARK CONSISTS OF STANDARD CHARACTERS WITHOUT CLAIM TO ANY PARTICULAR FONT, STYLE, SIZE, OR COLOR.

OWNER OF INTERNATIONAL REGISTRATION 1061295 DATED 10-6-2010, EXPIRES 10-6-2020.

CLASS 7—MACHINERY

FOR MACHINES AND MACHINE TOOLS, NAMELY, BRAKE TESTERS FOR TESTING THE BRAKES ON HEAVY VEHICLES; MOTORS AND ENGINES EXPECT FOR LAND VEHICLES; MACHINE COUPLING AND TRANSMISSION COMPONENTS EXCEPT FOR LAND VEHICLES (U.S. CLS. 13, 19, 21, 23, 31, 34 AND 35).

CLASS 12—VEHICLES

FOR LAND VEHICLES (U.S. CLS. 19, 21, 23, 31, 35 AND 44).

ANDREA HACK, EXAMINING ATTORNEY

SN 79-091,392. CMS DENTAL APS, DENMARK, FILED 11-5-2010.

FOTOSAN

THE MARK CONSISTS OF STANDARD CHARACTERS WITHOUT CLAIM TO ANY PARTICULAR FONT, STYLE, SIZE, OR COLOR.

PRIORITY DATE OF 5-7-2010 IS CLAIMED.

OWNER OF INTERNATIONAL REGISTRATION 1062034 DATED 11-5-2010, EXPIRES 11-5-2020.

CLASS 5—PHARMACEUTICALS

FOR MATERIALS FOR DENTAL TREATMENT, NAMELY, PHOTOSENSITIVE PREPARATIONS FOR DECONTAMINATION, DISINFECTION AND MICROBIOLOGICAL TREATMENT (U.S. CLS. 6, 18, 44, 46, 51 AND 52).

CLASS 10—MEDICAL APPARATUS

FOR DENTAL APPARATUS AND INSTRUMENTS, NAMELY, LIGHT EMITTING DEVICES FOR DECONTAMINATION, DISINFECTION AND MICROBIOLOGICAL TREATMENT (U.S. CLS. 26, 39 AND 44).

APRIL ROACH, EXAMINING ATTORNEY

SN 79-091,404. BETA GIDA SANAYI VE TICARET ANONIM SIRKETI, TURKEY, FILED 7-15-2010.

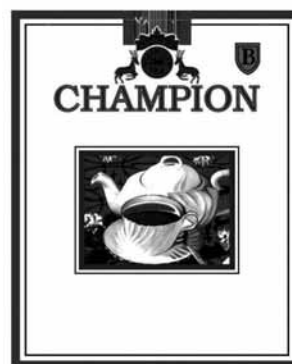

OWNER OF INTERNATIONAL REGISTRATION 1062068 DATED 7-15-2010, EXPIRES 7-15-2020.

NO CLAIM IS MADE TO THE EXCLUSIVE RIGHT TO USE "TEA", APART FROM THE MARK AS SHOWN.

THE MARK CONSISTS OF THE TERM "CHAMPION" AND THE WORDS "CHAMPION TEA" IN A CIRCLE. INSIDE THE CIRCLE IS AN ABSTRACT IMAGE OF A SQUIRREL. A DEER WITH ANTLERS APPEARS ON EACH SIDE OF THE CIRCLE. DIRECTLY ABOVE THE CIRCLE IS A BANNER-SHAPED DESIGN ADORNED WITH TEA LEAVES. DIRECTLY ABOVE THE LETTER "N" IN THE WORD "CHAMPION" IS A DRAWING OF A SHIELD CONTAINING THE LETTER "B". UNDERNEATH THE TERM "CHAMPION" INSIDE A DOUBLE LINED BOX IS THE IMAGE OF A TEA POT AND TEA CUP WHICH SITS ATOP A SAUCER AND HAS A SPOON TO THE SIDE. THE BACKGROUND OF THE BOX CONSISTS OF AN ABSTRACT DRAWING OF FOUR FLOWERS. THE ABOVE DESCRIBED WORDS AND DRAWINGS ARE ALL CONTAINED INSIDE A DOUBLE LINED RECTANGLE.

CLASS 29—MEATS AND PROCESSED FOODS

FOR MILK AND MILK PRODUCTS EXCLUDING ICE CREAM, ICE MILK AND FROZEN YOGURT; NUT-BASED MILK; CHOCOLATE MILK; MILK CURD; CREAM CHEESE; WHITE CHEESE; CHEESE; YOGURT; YOGURT DRINK; CLOTTED CREAM; WHIPPED CREAM; MILK POWDER; KEFIR; MILK BEVERAGES WITH HIGH MILK CONTENT; MILK DRINKS CONTAINING FRUIT; YOGURT WITH FRUITS; KOUMISS, NAMELY, MILK BEVERAGE AND DAIRY DESSERTS, NAMELY, MILK SHAKES (U.S. CL. 46).

CLASS 30—STAPLE FOODS

FOR COFFEE, COCOA, ARTIFICIAL COFFEE, CANDY CONTAINING MOCHA, COFFEE SUBSTITUTES, COFFEE OR COCOA-BASED BEVERAGES; TEA, ICED TEA (U.S. CL. 46).

GIANCARLO CASTRO, EXAMINING ATTORNEY

SN 79-091,469. CURTIS SYSTEMS GMBH, FED REP GERMANY, FILED 11-9-2010.



PRIORITY DATE OF 5-14-2010 IS CLAIMED.
OWNER OF INTERNATIONAL REGISTRATION 1062253 DATED 11-9-2010, EXPIRES 11-9-2020.
OWNER OF U.S. REG. NOS. 3,791,519, 3,791,520 AND 3,844,003.
THE COLOR(S) RED AND GREY IS/ARE CLAIMED AS A FEATURE OF THE MARK.
THE MARK CONSISTS OF THE STYLIZED REPRESENTATION OF THE LETTERS "CS".

CLASS 1—CHEMICALS

FOR INDUSTRIAL CHEMICALS, PARTICULARLY CHEMICAL AND PHYSICAL ACTING ADDITIVES FOR LUBRICANTS, LUBRICATING GREASES, INDUSTRIAL OILS AND FOR MOTOR OILS, GEAR OILS, COMPRESSOR OILS AND HYDRAULIC OILS, AS WELL AS ADDITIVES FOR FUELS, PARTICULARLY GASOLINE AND DIESEL OIL; ADDITIVES FOR LIQUIDS FOR COOLING ENGINES; CHEMICAL PREPARATIONS FOR MANUFACTURING OF COOLANTS, COOLING LUBRICANTS AND ANTI-CORROSIVE PREPARATIONS; WATER-MISCIBLE COOLANTS AND NON-WATER-MISCIBLE COOLANTS, AS WELL AS COOLING LUBRICANTS FOR GRINDING FOR METAL PROCESSING; CRYOGENIC PREPARATIONS IN SOLID, LIQUID, OR GAS STATE FOR USE IN CHILLING AND FREEZING (U.S. CLS. 1, 5, 6, 10, 26 AND 46).

CLASS 2—PAINTS

FOR ANTI-CORROSIVE PREPARATIONS IN THE NATURE OF COATINGS, OILS, LACQUERS, AND PAINTS; DUAL ANTI-CORROSIVE OILS; ANTI-CORROSIVE FLUIDS MADE WITH MINERAL OIL HYDROCARBONS FOR USE IN SURFACE PROTECTION; ANTI-RUST GREASES AND ANTI-RUST OILS, AS WELL AS ANTI-RUST PREPARATIONS FOR PRESERVATION, NAMELY, OILS, COATINGS, LACQUERS, AND PAINTS; PRESERVATIVES FOR VARNISHES; PROTECTIVE PREPARATIONS, NAMELY, COATINGS, OILS, LACQUERS, AND PAINTS FOR CHROMIUM FOR USE AS PROTECTIVE PREPARATIONS FOR METALS (U.S. CLS. 6, 11 AND 16).

CLASS 4—LUBRICANTS AND FUELS

FOR INDUSTRIAL GREASES AND INDUSTRIAL OILS, INCLUDING MOTOR, GEAR, COMPRESSOR OILS, AS WELL AS HYDRAULIC OILS; INDUSTRIAL OILS; ALL-PURPOSE LUBRICANTS; LUBRICATING OILS; CUTTING OILS; METAL FORMING OILS; DEEP HOLE CUTTING OILS; GRINDING OILS; PUNCHING OILS; NON-CHEMICAL ADDITIVES FOR TECHNICAL GREASES, TECHNICAL OILS; MOTOR OILS, GEAR OILS, COMPRESSOR OILS AND HYDRAULIC OILS, NON-CHEMICAL ADDITIVES FOR INDUSTRIAL OILS, AS WELL AS ADDITIVES, NON-CHEMICAL, TO MOTOR-FUEL, IN PARTICULAR TO GASOLINE AND DIESEL FUEL (U.S. CLS. 1, 6 AND 15).
VIVIAN MICZNIK FIRST, EXAMINING ATTORNEY

SN 79-091,659. NUCLEAR RESEARCH AND CONSULTANCY GROUP (NRG), V.O.F., NETHERLANDS, FILED 10-29-2010.

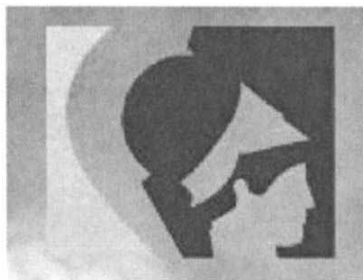

PRIORITY DATE OF 5-26-2010 IS CLAIMED.
OWNER OF INTERNATIONAL REGISTRATION 1062585 DATED 10-29-2010, EXPIRES 10-29-2020.
THE MARK CONSISTS OF THE SILHOUETTE OF A FACE IN THE LOWER RIGHT-HAND CORNER OF A RECTANGLE WITH VARIOUS UNDEFINED SHAPES FILLING IN THE REMAINING PART OF THE RECTANGLE.

CLASS 5—PHARMACEUTICALS

FOR ISOTOPES FOR MEDICAL USE (U.S. CLS. 6, 18, 44, 46, 51 AND 52).

CLASS 11—ENVIRONMENTAL CONTROL APPARATUS

FOR NUCLEAR REACTOR (U.S. CLS. 13, 21, 23, 31 AND 34).

CLASS 40—MATERIAL TREATMENT

FOR TREATMENT OF MATERIALS, NAMELY, THE RADIATION OF MATERIALS WITH AN IONIZING RADIATION (U.S. CLS. 100, 103 AND 106).

CLASS 42—SCIENTIFIC AND COMPUTER SERVICES

FOR DEVELOPMENT AND UPDATING OF SOFTWARE; ENGINEERING SERVICES; DEVELOPMENT OF PRODUCTS IN THE NUCLEAR FIELD; TECHNICAL RESEARCH IN THE FIELD OF NUCLEAR WASTE, NUCLEAR FUSION, NUCLEAR FUELS, MATERIALS AND REACTOR RELIABILITY (U.S. CLS. 100 AND 101).
SUE LAWRENCE, EXAMINING ATTORNEY

SN 79-091,783. BARRY CALLEBAUT AG, SWITZERLAND, FILED 11-30-2010.

Brillance Blanche

THE MARK CONSISTS OF STANDARD CHARACTERS WITHOUT CLAIM TO ANY PARTICULAR FONT, STYLE, SIZE, OR COLOR.

PRIORITY DATE OF 6-1-2010 IS CLAIMED.
OWNER OF INTERNATIONAL REGISTRATION 1062971 DATED 11-30-2010, EXPIRES 11-30-2020.
OWNER OF U.S. REG. NOS. 3,862,936 AND 3,862,938.
THE ENGLISH TRANSLATION OF "BRILLANCE BLANCHE" IN THE MARK IS WHITE BRILLIANCE.

CLASS 29—MEATS AND PROCESSED FOODS

FOR COCOA BUTTER FOR FOOD PURPOSES (U.S. CL. 46).

CLASS 30—STAPLE FOODS

FOR COCOA; COCOA POWDER; COCOA PRODUCTS, NAMELY, COCOA-BASED BEVERAGES, COCOA-BASED INGREDIENTS IN CONFECTIONERY PRODUCTS, AND NON-NUTRITIONAL FOOD ADDITIVES CONTAINING COCOA, NAMELY, COCOA MIXES AND NATURAL FOOD EXTRACTS DERIVED FROM COCOA; CHOCOLATE (U.S. CL. 46).

DAVID HOFFMAN, EXAMINING ATTORNEY

CLASS 16—PAPER GOODS AND PRINTED MATTER

FOR CARDBOARD BOXES FOR USE AS GIFT BOXES; PRINTED MATTER, DOCUMENTS AND PUBLICATIONS, NAMELY, PRINTED BROCHURES, PAMPHLETS, NEWSPAPERS, PERIODICALS, MAGAZINES, BOOKS, BOOKLETS, MANUALS, NEWSLETTERS, LEAFLET-CARDS, CATALOGS, AND LEAFLETS IN THE FIELD OF COSMETICS; CALENDARS; PHOTOGRAPH ALBUMS, POSTERS, STICKERS, POSTCARDS, ENVELOPES, NOTEPAPER; PRINTED VOUCHERS; PHOTOS; BANK GIFT CHECKS; NON-MAGNETICALLY ENCODED DEBIT AND CREDIT CARDS OF PLASTIC OR OF CARDBOARD, NON MAGNETICALLY ENCODED LOYALTY CARDS; DISCOUNT PRINTED VOUCHERS FOR THE PURCHASE OF GOODS AND/OR SERVICES; PROMOTIONAL AND/OR ADVERTISING PRINTED VOUCHERS INTENDED TO BE EXCHANGED FOR PRODUCTS AND/OR SERVICES (U.S. CLS. 2, 5, 22, 23, 29, 37, 38 AND 50).

SN 79-092,014. LABORATOIRE NUXE, FRANCE, FILED 3-24-2010.

NUXEBOX

THE MARK CONSISTS OF STANDARD CHARACTERS WITHOUT CLAIM TO ANY PARTICULAR FONT, STYLE, SIZE, OR COLOR.

PRIORITY DATE OF 9-24-2009 IS CLAIMED.
OWNER OF INTERNATIONAL REGISTRATION 1063597
DATED 3-24-2010, EXPIRES 3-24-2020.
OWNER OF U.S. REG. NO. 3,218,285.

CLASS 3—COSMETICS AND CLEANING PREPARATIONS

FOR PERFUMES, EAUX DE TOILETTE, EAU DE COLOGNE, PERSONAL DEODORANTS; ESSENTIAL OILS FOR PERSONAL USE; NON MEDICATED SOAPS, CLEANSING MILKS FOR TOILET PURPOSES; NON MEDICATED COSMETIC PREPARATIONS IN THE FORM OF CREAMS, GELS, MILKS, LOTIONS, BEAUTY MASKS, POMADES AND POWDERS; NON MEDICATED COSMETIC PREPARATIONS FOR SKIN CARE IN THE FORM OF CREAMS, GELS, MILKS, OILS AND LOTIONS; COSMETIC ANTI-WRINKLE PREPARATIONS NOT FOR MEDICAL USE IN THE FORM OF CREAMS, GELS, MILKS, OILS AND LOTIONS, BEAUTY MASKS AND POMADES; NON MEDICATED COSMETIC LIP-CARE PREPARATIONS IN THE FORM OF CREAMS, BALMS AND STICKS; COSMETIC SUNSCREEN PREPARATIONS IN THE FORM OF CREAMS, GELS, MILKS, OILS AND LOTIONS; COSMETIC SUNTAN PREPARATIONS IN THE FORM OF CREAMS, GELS, MILKS, OILS AND LOTIONS; COSMETIC AFTER-SUN PREPARATIONS IN THE FORM OF MILK, CREAMS, GELS, OILS AND LOTIONS; NON MEDICATED COSMETIC PREPARATIONS FOR SLIMMING PURPOSES; DEPILATORY PREPARATIONS IN THE FORM OF MOUSSES, CREAMS AND GELS; HAIR PRODUCTS, NAMELY, HAIR AND SCALP CARE PREPARATIONS, NAMELY, HAIR LOTIONS, SHAMPOOS, AFTER-SHAMPOOS, OILS AND MASKS FOR HAIR; NON MEDICATED COSMETIC BATH PREPARATIONS IN THE FORM OF CREAMS, GELS, MILKS, OILS, PEARLS AND SALTS; MAKE-UP AND MAKE-UP REMOVING PREPARATIONS, NAMELY, PRODUCTS IN THE FORM OF MOUSSES, GELS, MILKS, OILS AND LOTIONS (U.S. CLS. 1, 4, 6, 50, 51 AND 52).

CLASS 44—MEDICAL, BEAUTY AND AGRICULTURAL SERVICES

FOR BEAUTY CARE; MESSAGES; BEAUTY SALONS; CARE SERVICES, NAMELY, SAUNA SERVICES; BEAUTY SPA SERVICES, NAMELY, COSMETIC BODY CARE; BALNEOTHERAPY, PHYSIOTHERAPY, AND AROMATHERAPY SERVICES; HAMMAM SERVICES, NAMELY, TURKISH BATH SERVICES; HAIRDRESSING SALONS (U.S. CLS. 100 AND 101).

THEODORE MCBRIDE, EXAMINING ATTORNEY

SN 79-092,699. HOLLYS APS, DENMARK, FILED 1-5-2011.



PRIORITY DATE OF 7-15-2010 IS CLAIMED.
OWNER OF INTERNATIONAL REGISTRATION 1065527
DATED 1-5-2011, EXPIRES 1-5-2021.
THE MARK CONSISTS OF THE DESIGN OF A FOUR LEAF CLOVER.

CLASS 24—FABRICS

FOR BATH LINEN (U.S. CLS. 42 AND 50).

CLASS 25—CLOTHING

FOR CLOTHING, NAMELY, TROUSERS, BLOUSES, PANTS, JUMPSUITS, JUMP DRESSES, SHIRTS, T-SHIRTS, UNDERWEAR, BODY STOCKINGS, NIGHTWEAR, NAMELY, NIGHTDRESSES AND PYJAMAS (U.S. CLS. 22 AND 39).

DEBRA LEE, EXAMINING ATTORNEY

SN 79-093,460. NISSIN CHEMICAL INDUSTRY CO., LTD., JAPAN, FILED 1-27-2011.

FINESLICE

THE MARK CONSISTS OF STANDARD CHARACTERS WITHOUT CLAIM TO ANY PARTICULAR FONT, STYLE, SIZE, OR COLOR.

OWNER OF INTERNATIONAL REGISTRATION 1067260 DATED 1-27-2011, EXPIRES 1-27-2021.

CLASS 1—CHEMICALS

FOR AUXILIARY FLUIDS FOR USE WITH ABRASIVES FOR GENERAL INDUSTRIAL USE; INDUSTRIAL CHEMICALS (U.S. CLS. 1, 5, 6, 10, 26 AND 46).

CLASS 4—LUBRICANTS AND FUELS

FOR CUTTING FLUIDS (U.S. CLS. 1, 6 AND 15). MAYUR VAGHANI, EXAMINING ATTORNEY

SN 79-093,514. EURO SUISSE CORPORATION LIMITED C/O FORBES TAYLOR'S PIECE, ESSEX CM6 1DA, UNITED KINGDOM, FILED 11-12-2010.

KUG

OWNER OF INTERNATIONAL REGISTRATION 1067364 DATED 11-12-2010, EXPIRES 11-12-2020.

THE MARK CONSISTS OF THE WORDING "KUG" IN STYLIZED FONT.

CLASS 11—ENVIRONMENTAL CONTROL APPARATUS

FOR ELECTRIC APPARATUS FOR FILTERING AND BREWING COFFEE; AUTOMATIC MACHINES FOR MAKING COFFEE; BEVERAGE COOLING APPARATUS; ELECTRIC COFFEE MAKING APPARATUS; ELECTRIC COFFEE BEVERAGE MAKING APPARATUS; ELECTRIC COFFEE BREWERS; COFFEE FILTERS NOT OF PAPER BEING PART OF COFFEE MAKERS; ELECTRIC COFFEE MACHINES; ELECTRIC COFFEE MAKING MACHINES; ELECTRIC COFFEE POTS; ELECTRIC KETTLES; ELECTRIC TEA KETTLES; ELECTRICALLY-OPERATED APPARATUS FOR MAKING COFFEE; ELECTRIC MACHINES FOR MAKING COFFEE; WATER HEATERS; ELECTRIC HEATING FILAMENTS; OVENS FOR COOKING; APPARATUS FOR HEATING, NAMELY, ELECTRIC BOTTLE WARMERS, HOT PLATES (U.S. CLS. 13, 21, 23, 31 AND 34).

CLASS 21—HOUSEWARES AND GLASS

FOR BEER MUGS; BEVERAGE BOTTLES, SOLD EMPTY; PORTABLE BEVERAGE COOLERS; COFFEE CUPS; COFFEE MUGS; COFFEE SERVICES; CUPS; DRINKING FLASKS; DRINKING FLASKS FOR TRAVELERS; DRINKING VESSELS; HAND-OPERATED COFFEE GRINDERS; HEAT-INSULATED CONTAINERS FOR BEVERAGES; HEAT-INSULATED CONTAINERS; INSULATED VACUUM BOTTLES; INSULATING FLASKS; KITCHEN UTENSILS, NAMELY, TEA INFUSERS, TEA STRAINERS; MUGS; MUGS MADE OF PLASTIC; NON-ELECTRIC COFFEE MAKERS; NON-ELECTRIC COFFEE BREWERS; NON-ELECTRIC COFFEE POTS; COFFEE FILTERS NOT OF PAPER BEING PART OF NON-ELECTRIC COFFEE MAKERS; NON-ELECTRIC KETTLES; NON-ELECTRIC TEA KETTLES; PORTABLE COOLERS; POTS; TEA POTS; THERMALLY INSULATED CONTAINERS FOR BEVERAGES; THERMALLY INSULATED FLASKS FOR BEVERAGES; VACUUM FLASKS FOR HOLDING DRINKS; BEVERAGE GLASSWARE; HOUSEHOLD OR KITCHEN UTENSILS, NAMELY, SPOONS AND ICE TONGS; ICE PAIL COOLERS (U.S. CLS. 2, 13, 23, 29, 30, 33, 40 AND 50). DANIEL CAPSHAW, EXAMINING ATTORNEY

SN 79-093,783. APP-TECH S.R.L., ITALY, FILED 12-29-2010.

APP TECH

PRIORITY DATE OF 12-14-2010 IS CLAIMED. OWNER OF INTERNATIONAL REGISTRATION 1067721 DATED 12-29-2010, EXPIRES 12-29-2020.

NO CLAIM IS MADE TO THE EXCLUSIVE RIGHT TO USE "TECH", APART FROM THE MARK AS SHOWN.

THE TRADEMARK IS COMPOSED OF TWO WORDS "APP" AND "TECH" IN CAPITAL BLOCK LETTERS, DIVIDED BY A GRAPHIC SIGN.

CLASS 6—METAL GOODS

FOR METAL BOLTS, METAL NUTS, METAL SCREWS AND METAL RIVETS (U.S. CLS. 2, 12, 13, 14, 23, 25 AND 50).

CLASS 12—VEHICLES

FOR PARTS AND ACCESSORIES FOR VEHICLES, NAMELY, ALUMINUM AND STEEL WHEEL RIMS AND TIRE CHAINS (U.S. CLS. 19, 21, 23, 31, 35 AND 44).

CLASS 37—CONSTRUCTION AND REPAIR

FOR MAINTENANCE, REPAIR, AND INSTALLATION OF RIMS FOR VEHICLES; SUPPORT IN THE NATURE OF REPAIR ADVICE FOR RIMS FOR VEHICLES (U.S. CLS. 100, 103 AND 106).

CLASS 42—SCIENTIFIC AND COMPUTER SERVICES

FOR SERVICES OF ENGINEERING AND DEVELOPMENT OF RIMS FOR VEHICLES (U.S. CLS. 100 AND 101).

CHARLOTTE CORWIN, EXAMINING ATTORNEY

SN 79-093,869. WESTERN AUSTRALIAN TOURISM COMMISSION, PERTH, AUSTRALIA, FILED 12-21-2010.

SN 79-093,975. ART DEFENDER S.P.A., ITALY, FILED 10-7-2010.

EXPERIENCE
EXTRAORDINARY

OWNER OF INTERNATIONAL REGISTRATION 1067938
DATED 12-21-2010, EXPIRES 12-21-2020.

CLASS 35—ADVERTISING AND BUSINESS

FOR PROMOTION AND ADVERTISING SERVICES IN RELATION TO TOURISM, THE AUSTRALIAN TOURIST INDUSTRY, TRAVEL AND HOLIDAYS; BUSINESS MANAGEMENT AND BUSINESS ADMINISTRATION SERVICES INCLUDING CONSULTATION IN THE REALIZATION AND ORGANIZATION OF FAIRS, TRADE SHOWS AND EXHIBITIONS FOR BUSINESS AND ADVERTISING PURPOSES; MARKET RESEARCH AND MARKET ANALYSIS SERVICES; COORDINATING AND CONDUCTING TRADE SHOWS IN THE FIELD OF TOURISM, THE AUSTRALIAN TOURIST INDUSTRY, TRAVEL AND HOLIDAYS; INFORMATION AND CONSULTANCY SERVICES RELATING TO THE AFOREMENTIONED SERVICES; ALL THE AFOREMENTIONED SERVICES RELATED TO TOURISM (U.S. CLS. 100, 101 AND 102).

CLASS 39—TRANSPORTATION AND STORAGE

FOR TRAVEL ARRANGEMENT; TRAVEL BOOKING SERVICES, NAMELY, COMPUTERIZED TRANSPORTATION TICKETING SERVICES AND TRAVEL TICKET TICKETING SERVICES; TRAVEL AGENCY SERVICES, NAMELY, MAKING RESERVATIONS AND BOOKINGS FOR TRANSPORTATION; PROVISION OF TRAVEL INFORMATION; PROVISION OF NONDOWNLOADABLE INFORMATION ABOUT TRANSPORTATION, TRAVEL AS IT RELATES TO TOURISM, TRAVEL AS IT RELATES TO THE AUSTRALIAN TOURIST INDUSTRY AND TRAVEL DURING THE HOLIDAYS; INFORMATION AND CONSULTANCY SERVICES RELATING TO THE AFOREMENTIONED SERVICES; ALL THE AFOREMENTIONED SERVICES RELATING TO TOURISM (U.S. CLS. 100 AND 105).

CLASS 41—EDUCATION AND ENTERTAINMENT

FOR EDUCATION SERVICES, NAMELY, SEMINARS RELATING TO TOURISM, THE AUSTRALIAN TOURIST INDUSTRY, TRAVEL AND HOLIDAYS; ORGANIZING COMMUNITY SPORTING AND CULTURAL ACTIVITIES; ORGANIZING AND CONDUCTING SPORTS EVENTS; BOOKING AND TICKETING SERVICES FOR SPORTS, ENTERTAINMENT, CULTURAL AND EDUCATIONAL EVENTS; COORDINATING AND CONDUCTING FAIRS AND EXHIBITIONS FOR EDUCATIONAL AND ENTERTAINMENT PURPOSES, NAMELY, FAIRS AND EXHIBITIONS RELATING TO TOURISM, THE AUSTRALIAN TOURIST INDUSTRY, TRAVEL AND HOLIDAYS; PUBLISHING SERVICES, NAMELY, PUBLISHING OF MAGAZINES, BOOKS, MAPS, BROCHURES, PAMPHLETS, FLYERS, CATALOGS AND PROVISION OF NON-DOWNLOADABLE INFORMATION ABOUT SPORTING AND CULTURAL EVENTS, OVER A GLOBAL COMPUTER NETWORK; INFORMATION AND CONSULTANCY SERVICES RELATING TO THE AFOREMENTIONED SERVICES; ALL OF THE AFOREMENTIONED SERVICES RELATING TO TOURISM (U.S. CLS. 100, 101 AND 107).

MELISSA VALLILLO, EXAMINING ATTORNEY



PRIORITY DATE OF 6-11-2010 IS CLAIMED.

OWNER OF INTERNATIONAL REGISTRATION 1068177
DATED 10-7-2010, EXPIRES 10-7-2020.

NO CLAIM IS MADE TO THE EXCLUSIVE RIGHT TO USE "ART", APART FROM THE MARK AS SHOWN.

THE COLOR(S) YELLOW, BLACK, GREY, BLUE AND WHITE IS/ARE CLAIMED AS A FEATURE OF THE MARK. THE MARK CONSISTS OF THE IMAGE OF A TIGER HOLDING A BABY TIGER IN ITS MOUTH; THE TIGERS APPEAR IN THE COLORS BLACK, GRAY AND YELLOW ON A YELLOW RECTANGULAR BACKGROUND IN THE TOP TWO THIRDS OF THE MARK; THE LITERAL ELEMENTS "ART DEFENDER LO SPAZIO PER L'ARTE" APPEAR IN WHITE WITH A YELLOW MISCELLANEOUS DESIGN UNDER THE WORDS WHICH APPEAR IN THE BOTTOM THIRD OF THE MARK ON A BLUE BACKGROUND.

THE ENGLISH TRANSLATION OF THE FOREIGN WORD(S) IN THE MARK IS: "ART DEFENDER THE SPACE FOR ART".

CLASS 37—CONSTRUCTION AND REPAIR

FOR CONSERVATION AND PRESERVATION SERVICES FOR WORKS OF ART; RESTORATION OF WORKS OF ART (U.S. CLS. 100, 103 AND 106).

CLASS 39—TRANSPORTATION AND STORAGE

FOR TRANSPORT AND STORAGE OF GOODS (U.S. CLS. 100 AND 105).

CLASS 45—PERSONAL AND LEGAL SERVICES

FOR SECURITY GUARD SERVICES FOR PROTECTING WORKS OF ART; SURVEILLANCE SERVICES FOR PROTECTING WORKS OF ART (U.S. CLS. 100 AND 101).
CHRISIE B. KING, EXAMINING ATTORNEY

SN 79-094,044. GRUPO ANTOLIN-INGENIERIA, S.A., SPAIN, FILED 12-3-2010.

GRANPH

THE MARK CONSISTS OF STANDARD CHARACTERS WITHOUT CLAIM TO ANY PARTICULAR FONT, STYLE, SIZE, OR COLOR.

OWNER OF INTERNATIONAL REGISTRATION 1068321
DATED 12-3-2010, EXPIRES 12-3-2020.

THE WORDING "GRANPH" HAS NO MEANING IN A FOREIGN LANGUAGE.

CLASS 1—CHEMICALS

FOR ARTIFICIAL GRAPHITE, CARBON AND GRAPHENE, NAMELY, A SINGLE SHEET OF ARTIFICIAL GRAPHITE FOR INDUSTRIAL USE (U.S. CLS. 1, 5, 6, 10, 26 AND 46).

CLASS 9—ELECTRICAL AND SCIENTIFIC APPARATUS

FOR SEMI-CONDUCTORS, MICROPROCESSORS, COMPUTERS, BLANK HARD DRIVES FOR COMPUTERS, PHOTOVOLTAIC CELLS, APPARATUS AND INSTRUMENTS FOR CONDUCTING, SWITCHING, TRANSFORMING, ACCUMULATING, REGULATING OR CONTROLLING ELECTRICITY, NAMELY, ELECTRIC CONDUCTORS, ELECTRIC SWITCHES AND ELECTRIC TRANSFORMERS; APPARATUS FOR RECORDING, TRANSMITTING OR REPRODUCING SOUND OR IMAGES, ELECTRICAL CONDENSERS, OPTICAL CONDENSERS, COMPUTER MONITORS; CLOTHING, FOOTWEAR, MASKS, HELMETS AND FACE-PROTECTION SHIELDS ALL FOR PROTECTION AGAINST ACCIDENTS, BULLET-PROOF VESTS (U.S. CLS. 21, 23, 26, 36 AND 38).

CLASS 11—ENVIRONMENTAL CONTROL APPARATUS

FOR LIGHTS FOR VEHICLES, VEHICLE REFLECTORS (U.S. CLS. 13, 21, 23, 31 AND 34).

CLASS 12—VEHICLES

FOR VEHICLE WINDSCREENS, BALL-AND-SOCKET JOINTS AND ARMS FOR VEHICLE STEERING SYSTEMS; VEHICLE STEERING SYSTEMS COMPRISED OF STEERING UNITS FOR LAND VEHICLES AND PARTS THEREOF; VEHICLE SEATS; VEHICLE SEAT COVERS AND REINFORCING MATERIALS IN THE NATURE OF VEHICLE SEAT PROTECTORS; LAND VEHICLE ROOF PANELS; LAND VEHICLE DOOR PANELS; VEHICLE DOOR FITTINGS, NAMELY, ARTIFICIAL GRAPHITE, CARBON AND GRAPHENE PARTS FOR VEHICLES, NAMELY, AUTOMOTIVE EXTERIOR AND INTERIOR DECORATIVE AND PROTECTIVE TRIM; LOCKS AND LATCHES FOR BEING STRUCTURAL PARTS OF LAND VEHICLE HOODS AND TRUNKS; VEHICLE TRAYS IN THE NATURE OF VEHICLE ACCESSORIES, NAMELY, TAILGATE TRAYS; BALL-AND-SOCKET JOINTS BEING STRUCTURAL PARTS OF SUSPENSION SYSTEMS FOR AUTOMOBILES AND SUSPENSION SYSTEMS FOR AUTOMOBILES; VEHICLE DOOR LATCHES AND DOOR BRAKES BEING STRUCTURAL PARTS OF LAND VEHICLE DOORS; MANUAL, ELECTRICAL AND ELECTRONIC WINDOW CONTROL SYSTEMS FOR VEHICLES BEING STRUCTURAL PARTS OF LAND VEHICLES COMPRISED OF MANUAL, ELECTRICAL AND ELECTRONIC WINDOW LIFTS FOR VEHICLES; CRANKCASES FOR COMPONENTS FOR MOTOR CARS; VEHICLE MECHANISMS AND TRANSMISSION SYSTEMS, NAMELY, TRANSMISSIONS FOR LAND VEHICLES; VEHICLE FITTINGS, NAMELY, AUTOMOTIVE INTERIOR TRIMS; BODYWORKS FOR MOTOR VEHICLES; AUTOMOTIVE INTERIOR CEILING LINERS; DASHBOARDS AND AUTOMOTIVE INTERIOR TRIMS; AUTOMOTIVE INTERIOR PANELING, NAMELY, VIBRATION AND SHOCK ABSORBING LININGS FOR VEHICLE INTERIORS (U.S. CLS. 19, 21, 23, 31, 35 AND 44).

CLASS 17—RUBBER GOODS

FOR CONNECTING HOSES AND SLEEVES FOR VEHICLE RADIATORS; ARTIFICIAL AND SYNTHETIC RESINS, NAMELY, SYNTHETIC ELASTOMER RESIN BLENDED WITH ADDITIVES AND COLORANTS SOLD IN A PELLET FORM, SEMI-WORKED SYNTHETIC PLASTIC AND SYNTHETIC RESINS AS SEMI-FINISHED PRODUCTS IN FORM OF PELLETS, RODS, FOILS, FOAMS, FIBERS, FILMS AND SHEETS; INSULATORS AND INSULATING FABRICS, NAMELY, AUTOMOTIVE INTERIOR ELECTRIC, THERMAL AND ACOUSTIC INSULATORS FOR VEHICLES; CARBON FIBERS OTHER THAN FOR TEXTILE USE (U.S. CLS. 1, 5, 12, 13, 35 AND 50).

CLASS 22—CORDAGE AND FIBERS

FOR CARBON FIBERS FOR TEXTILE USE (U.S. CLS. 1, 2, 7, 19, 22, 42 AND 50).

CLASS 27—FLOOR COVERINGS

FOR FLOOR COVERINGS (U.S. CLS. 19, 20, 37, 42 AND 50).

KATHERINE E. HALMEN, EXAMINING ATTORNEY

SN 79-094,097. GEA BREWERY SYSTEMS GMBH, FED REP GERMANY, FILED 10-29-2010.

ECOPROP

THE MARK CONSISTS OF STANDARD CHARACTERS WITHOUT CLAIM TO ANY PARTICULAR FONT, STYLE, SIZE, OR COLOR.

PRIORITY DATE OF 6-2-2010 IS CLAIMED.

OWNER OF INTERNATIONAL REGISTRATION 1068496 DATED 10-29-2010, EXPIRES 10-29-2020.

CLASS 6—METAL GOODS

FOR SETTLING VATS OF METAL; CONTAINERS OF METAL USED AS VATS OR PRESSURE TANKS, ALSO FITTED WITH REGULATING MECHANISMS IN PARTICULAR FOR PRESSURE, TEMPERATURE OR FOR PUMPS TO PROMOTE THE FLOW OF THE CONTENTS OF THE CONTAINER; TANKS AND CONTAINERS OF METAL, IN PARTICULAR YEAST TANKS, YEAST STORAGE TANKS, FERMENTATION TANKS, PRESSURIZED FERMENTATION TANKS, BUFFER TANKS, CONTAINERS FOR MIXING PURPOSES AND SURGE TANKS; FERMENTING CELLARS MAINLY CONSISTING OF TANKS MADE OF METAL (U.S. CLS. 2, 12, 13, 14, 23, 25 AND 50).

CLASS 7—MACHINERY

FOR MACHINES AND MACHINERY INSTALLATIONS FOR THE MANUFACTURE, TREATING, PROCESSING AND REFINING OF FOODSTUFFS AND LUXURY FOODSTUFFS AND OF BEVERAGES AND FRUIT JUICES, IN PARTICULAR FOR MIXING, STORING AND PURIFYING; MACHINES AND MACHINERY INSTALLATIONS FOR THE FOOD, BREWING AND DRINKS INDUSTRIES, NAMELY, MACHINES FOR BREWING BEVERAGES AND FOR AUTOMATED WORT AND FERMENTING LINES FOR PRODUCING YEAST CULTURES MAINLY CONSISTING OF TANKS, PIPELINES, VALVES, PUMPS, NAMELY, YEAST PROPAGATION PUMPS; MACHINES FOR TREATMENT, PROCESSING AND FINISHING, NAMELY, FOR THE MIXING, STORAGE AND PURIFYING OF MILK AND MILK PRODUCTS; PUMPS AND JET PUMPS, NAMELY, ROTARY PUMPS, BOX PUMPS, PISTON PUMPS, LIQUID PUMPS, CIRCULATION PUMPS, FEED PUMPS, HAND-OPERATED AND/OR MECHANICALLY OPERATED VALVES BEING MACHINE PARTS; MACHINE-TYPE DEVICES FOR TREATING LIQUIDS AND FLUIDS, NAMELY, BEVERAGE PREPARATION MACHINES, ELECTROMECHANICAL AND FERMENTATION CELLARS; PROCESSING INSTALLATIONS FOR FOODSTUFFS AND DRINKS, NAMELY, TANK STORAGE SYSTEMS CONNECTED WITH PIPE SYSTEMS, MAINLY CONSISTING OF PIPELINES, VALVES, PUMPS AND MEASURING, CONTROL AND REGULATING DEVICES; MACHINE PARTS, NAMELY, VALVES AND TAPS AS PARTS OF APPARATUS AND MACHINES FOR THE MANUFACTURE OF DRINKS, NAMELY, HAND-OPERATED AND REMOTE-CONTROLLED DISPOSABLE AND MULTI-USE, SHUT-OFF, BY-PASS AND MIXING VALVES, SLIDE VALVES, NON-RETURN VALVES, AND TAPS FOR LIQUIDS OR GASES; MACHINES, APPARATUS AND MECHANICAL EQUIPMENT, NAMELY, WHIRLPOOLS AND WORTCOOLER FOR THE BREWING AND DRINKS INDUSTRY (U.S. CLS. 13, 19, 21, 23, 31, 34 AND 35).

CLASS 11—ENVIRONMENTAL CONTROL APPARATUS

FOR MECHANICAL EQUIPMENT, NAMELY, FOR HEAT TREATMENT, HEATING, SUPERHEATING, PASTEURIZATION, REFRIGERATION, FREEZING, AND INSTALLATIONS CONSISTING ENTIRELY OR MAINLY OF THE AFORESAID MACHINES, APPARATUS AND/OR EQUIPMENT FOR THE MANUFACTURE, TREATING, PROCESSING AND REFINING OF FOODSTUFFS AND LUXURY ITEMS FOODSTUFFS AND OF LIQUIDS, BEVERAGES AND FRUIT JUICES, REFRIGERATION INSTALLATIONS; HEAT EXCHANGERS, NAMELY, PLATE HEAT EXCHANGERS, TUBULAR HEAT EXCHANGERS, HEATING JACKETS, HEATING TUBE BUNDLES, HEATING COILS, TUBULAR EVAPORATORS, PLATE HEATERS, SPIRAL HEAT EXCHANGERS, PLATE EVAPORATORS; APPARATUS, MACHINES AND REQUISITES FOR THE ENTIRE FOOD AND DRINKS INDUSTRY, NAMELY, PASTEURIZATION MACHINES AND APPARATUS, NAMELY, PASTEURIZER CONSISTING OF PLATE HEAT EXCHANGERS, TUBULAR HEAT EXCHANGERS, HEATING JACKETS, HEATING TUBE BUNDLES, HEATING COILS, TUBULAR EVAPORATORS, PLATE HEATERS, SPIRAL HEAT EXCHANGERS AND/OR PLATE EVAPORATORS, STERILIZING APPARATUS AND MACHINES, NAMELY, STERILIZER INTER ALIA CONSISTING OF PLATE HEAT EXCHANGERS, TUBULAR HEAT EXCHANGERS, HEATING JACKETS, HEATING TUBE BUNDLES, HEATING COILS, TUBULAR EVAPORATORS, PLATE HEATERS, SPIRAL HEAT EXCHANGERS AND/OR PLATE EVAPORATORS, HEAT INSTALLATIONS FOR UTILIZING THE WASTE HEAT FROM COOLING OPERATIONS; HEAT PUMPS; PLATE HEAT EXCHANGERS (U.S. CLS. 13, 21, 23, 31 AND 34).
KAREN SEVERSON, EXAMINING ATTORNEY

SN 79-094,200. KARL STORZ GMBH & CO. KG, TUTTLINGEN, FED REP GERMANY, FILED 1-25-2011.

OR1 NEO

PRIORITY DATE OF 7-30-2010 IS CLAIMED.
OWNER OF INTERNATIONAL REGISTRATION 1068808 DATED 1-25-2011, EXPIRES 1-25-2021.
OWNER OF U.S. REG. NOS. 2,813,349 AND 3,532,358.
THE MARK CONSISTS OF THE TERM "OR1" IMMEDIATELY TO THE LEFT OF THE LETTERING "NEO". THE LETTERING "NEO" APPEARS IN A STYLIZATION EVOKING BRUSHSTROKES.

CLASS 9—ELECTRICAL AND SCIENTIFIC APPARATUS

FOR APPARATUS FOR RECORDING, TRANSMISSION OR REPRODUCTION OF SOUND OR IMAGES; DATA PROCESSING APPARATUS, NAMELY, DATA PROCESSORS AND COMPUTERS; COMPUTER PERIPHERALS, COMPUTER HARDWARE, COMPUTER PROGRAMS, BLANK MAGNETIC DATA CARRIERS, AND BLANK OPTICAL DATA READERS AND CARRIERS FOR DOCUMENTING THE RESULTS OF ENDOSCOPIC PROCEDURES; CAMERAS, MICROSCOPES; REMOTE CONTROLS FOR MEDICAL APPARATUS AND INSTRUMENTS; DOWNLOADABLE ELECTRONIC PUBLICATIONS IN THE NATURE OF INSTRUCTIONAL AND TEACHING BOOKS AND SHEETS IN THE FIELDS OF MEDICAL TECHNOLOGY (U.S. CLS. 21, 23, 26, 36 AND 38).

CLASS 10—MEDICAL APPARATUS

FOR SURGICAL AND MEDICAL APPARATUS FOR USE IN GENERAL AND ENDOSCOPIC SURGERY (U.S. CLS. 26, 39 AND 44).

CLASS 16—PAPER GOODS AND PRINTED MATTER

FOR PRINTED MATTER, NAMELY, CATALOGUES, MAGAZINES, JOURNALS, BROCHURES AND INFORMATIONAL FLYERS, LETTERS AND SHEETS IN THE FIELD OF MEDICAL TECHNOLOGY; PRINTED TEACHING AND INSTRUCTIONAL MANUALS IN THE FIELD OF MEDICAL TECHNOLOGY; PHOTOGRAPHS (U.S. CLS. 2, 5, 22, 23, 29, 37, 38 AND 50).
NAPOLÉON SHARMA, EXAMINING ATTORNEY

SN 79-094,252. FRANZ WÖLFER ELEKTROMASCHINEN-FABRIK OSNABRÜCK GMBH, OSNABRÜCK, FED REP GERMANY, FILED 12-23-2010.

Wölfer moves the world

OWNER OF INTERNATIONAL REGISTRATION 1068882 DATED 12-23-2010, EXPIRES 12-23-2020.
THE COLOR(S) RED IS/ARE CLAIMED AS A FEATURE OF THE MARK.
THE MARK CONSISTS OF THE FOLLOWING: THE WORDING "WÖLFER MOVES THE WORLD" IN THE COLOR RED.

CLASS 7—MACHINERY

FOR ELECTRIC MOTORS OTHER THAN FOR LAND VEHICLES (U.S. CLS. 13, 19, 21, 23, 31, 34 AND 35).

CLASS 9—ELECTRICAL AND SCIENTIFIC APPARATUS

FOR APPARATUS AND INSTRUMENTS FOR REGULATING AND CONTROLLING ELECTRIC CURRENT (U.S. CLS. 21, 23, 26, 36 AND 38).

CLASS 12—VEHICLES

FOR MOTORS, ELECTRIC, FOR LAND VEHICLES (U.S. CLS. 19, 21, 23, 31, 35 AND 44).
APRIL ROACH, EXAMINING ATTORNEY

SN 79-094,579. HITACHI KINZOKU KABUSHIKI KAISHA (HITACHI METALS, LTD.), JAPAN, FILED 9-22-2010.

NEOMAX

OWNER OF INTERNATIONAL REGISTRATION 1069707 DATED 9-22-2010, EXPIRES 9-22-2020.

OWNER OF U.S. REG. NOS. 3,078,643, 3,108,708 AND OTHERS.

THE MARK CONSISTS OF THE WORDING "NEOMAX" IN STYLIZED FONT.

CLASS 6—METAL GOODS

FOR CLAD METALS CONSISTING OF PRESSURE-WELDED STAINLESS STEELS, IRONS AND STEELS, AND NONFERROUS METALS AND THEIR ALLOYS; IRONS AND STEEL; CLAD METALS CONSISTING OF PRESSURE-WELDED NICKEL ALLOYS, COPPER ALLOYS, CHROME ALLOYS, TITANIUM ALLOYS, AND NONFERROUS METALS AND THEIR ALLOYS; BRAZING ALLOY FILLER METALS (U.S. CLS. 2, 12, 13, 14, 23, 25 AND 50).

CLASS 7—MACHINERY

FOR ELECTRIC GENERATORS FOR WIND TURBINES; DAMPING MACHINES USING PERMANENT MAGNETS FOR BRIDGE CABLES; DAMPING MACHINES FOR BRIDGE CABLES; PRINTING AND BOOK-BINDING MACHINES AND APPARATUS, NAMELY, TORQUE LIMITERS USING PERMANENT MAGNETS FOR PAPER FEED DEVICES IN PRINTING MACHINES; METALWORKING MACHINES AND MACHINE TOOLS, NAMELY, STAGES FOR METALWORKING MACHINES AND MACHINE TOOLS USING LINEAR MOTORS INCLUDING BUILT-IN PERMANENT MAGNETS; LOADING-UNLOADING MACHINES USING PERMANENT MAGNETS; LOADING-UNLOADING MACHINES; CONCRETE CONSTRUCTION MACHINES; LINEAR MOTORS USING PERMANENT MAGNETS FOR SEMICONDUCTOR MANUFACTURING MACHINES AND SYSTEMS; LINEAR MOTORS FOR SEMICONDUCTOR MANUFACTURING MACHINES AND SYSTEMS; ELECTROMAGNETIC ACTUATORS USING PERMANENT MAGNETS FOR SEMICONDUCTOR MANUFACTURING MACHINES AND SYSTEMS; ELECTROMAGNETIC ACTUATORS FOR SEMICONDUCTOR MANUFACTURING MACHINES AND SYSTEMS; MAGNETIC FIELD GENERATING DEVICES FOR SPUTTERING FOR MANUFACTURING OF SEMICONDUCTORS, LCDS AND SOLAR BATTERIES; SEMICONDUCTOR MANUFACTURING MACHINES AND SYSTEMS; STARTERS FOR MOTORS AND ENGINES; AC MOTORS AND DC MOTORS OTHER THAN FOR LAND VEHICLES; COMPONENTS FOR AC MOTORS AND DC MOTORS FOR LAND VEHICLES, NAMELY, STATORS AND ROTORS; WASTE SEPARATING MACHINES USING PERMANENT MAGNETS FOR SEPARATING ALUMINUM WASTE, MAGNETIC METALS AND NONMETALS; WASTE SEPARATING MACHINES; WASTE COMPACTING MACHINES; WASTE CRUSHING MACHINES; PARTS FOR NON-ELECTRIC MOTORS FOR LAND VEHICLES NAMELY, MAGNETS AND ROTORS FOR LINEAR MOTORS USING PERMANENT MAGNETS FOR RAILWAY ROLLING STOCKS, RO-

TORS FOR MOTORS USING PERMANENT MAGNETS FOR HYBRID ELECTRIC-POWERED BICYCLES, AND ROTORS FOR MOTORS USING PERMANENT MAGNETS FOR ELECTRIC AUTOMOBILES OR HYBRID ELECTRIC AUTOMOBILES; NON-ELECTRIC MOTORS, NOT FOR LAND VEHICLES, FOR PRINTING MACHINES, METALWORKING MACHINES, SEMI-CONDUCTOR MANUFACTURE MACHINES, WASTE SEPARATING MACHINES, TELECOMMUNICATION MACHINES FOR OPTICAL DISC DRIVES, METAL PROCESSING MACHINES AND PLASTIC PROCESSING MACHINES; PNEUMATIC AND HYDRAULIC MACHINES, NAMELY, PUMPS, VACUUM PUMPS, BLOWERS AND COMPRESSORS; TRANSMISSION COMPONENTS NAMELY, MAGNETIC COUPLINGS FOR NON-CONTACT TRANSMISSION OF ROTARY TORQUE FOR PUMPS, MANUFACTURING MACHINES AND COMPUTERS; MACHINE ELEMENTS NOT FOR LAND VEHICLES NAMELY, SHAFT COUPLINGS, POWER TRANSMISSIONS AND GEARINGS FOR MACHINES (U.S. CLS. 13, 19, 21, 23, 31, 34 AND 35).

CLASS 9—ELECTRICAL AND SCIENTIFIC APPARATUS

FOR BATTERIES AND CELLS, NAMELY, DRYCELLS, STORAGE BATTERIES AND SOLAR BATTERIES; ELECTRIC OR MAGNETIC METERS AND TESTERS, NAMELY, MAGNETOMETERS, WATT HOUR METERS, VOLTMETERS, AMMETERS AND WATTMETERS; ELECTRIC WIRES AND CABLES; PHOTOGRAPHIC INSTRUMENTS, APPARATUS AND THEIR PARTS, NAMELY, CAMERAS AND STRUCTURAL PARTS THEREOF; CINEMATOGRAPHIC INSTRUMENTS AND APPARATUS, NAMELY, MOTION PICTURE AND MOVIE CAMERAS AND PROJECTORS AND STRUCTURAL PARTS THEREOF; OPTICAL APPARATUS AND INSTRUMENTS, NAMELY, TELESCOPES AND MICROSCOPES; TELECOMMUNICATION MACHINES AND APPARATUS, NAMELY, VOICE COIL MOTORS USING PERMANENT MAGNETS FOR OPTICAL DISK DRIVES FOR REPRODUCTION OF MUSIC OR IMAGES; TORQUE LIMITERS USING PERMANENT MAGNETS FOR PAPER FEED DEVICES IN FACSIMILE MACHINES; MAGNETIC DAMPERS CONSISTING OF A COMBINATION OF PLURAL PERMANENT MAGNETS FOR OPENING INSERTION SITES OF DISC AND CASSETTE DEVICES; ELECTRONIC MACHINES AND APPARATUS, NAMELY, UNDULATORS FOR PRODUCING SYNCHROTRON RADIATION INCLUDING X-RAY USING PERMANENT MAGNETS; VOICE COIL MOTORS USING PERMANENT MAGNETS FOR POSITIONING ACTUATORS FOR MAGNETIC HEADS OF MAGNETIC DISCS; VOICE COIL MOTORS USING PERMANENT MAGNETS FOR OPTICAL DISK DRIVES IN COMPUTERS; ELECTRONIC SUBSTRATES FOR THIN FILM MAGNETIC HEADS OF MAGNETIC DISKS; TONER ABSORPTION EQUIPMENT USING PERMANENT MAGNETS IN ELECTROSTATIC COPYING MACHINES; TORQUE LIMITERS USING PERMANENT MAGNETS FOR PAPER FEED DEVICES IN PRINTERS FOR ELECTROSTATIC COPYING MACHINES OR COMPUTERS; SPACER RINGS OF CERAMICS USING PERMANENT MAGNETS FOR LAMINATED MAGNETIC DISKS; PERMANENT MAGNETS; MAGNETIC POWDER FOR PERMANENT MAGNETS; MAGNETIC CORES; RESISTANCE WIRES; ELECTRODES; ELECTRIC POWER DISTRIBUTION OR CONTROL MACHINES AND APPARATUS, NAMELY, SWITCHING POWER SUPPLY TRANSFORMERS; SWITCHING POWER SUPPLY CHOKE COILS; SWITCHING POWER SUPPLY INDUCTORS; DC/DC CONVERTERS; ROTARY CONVERTERS AND PHASE MODIFIERS (U.S. CLS. 21, 23, 26, 36 AND 38).

CLASS 10—MEDICAL APPARATUS

FOR MEDICAL MACHINES AND APPARATUS, NAMELY, MAGNETIC RESONANCE IMAGING DIAGNOSTIC APPARATUS USING PERMANENT MAGNETS; MRI DIAGNOSTIC APPARATUS, TOMOGRAPHY MACHINES, NAMELY, COMPUTED TOMOGRAPHY (CT) APPARATUS; MEDICAL ULTRASOUND APPARATUS, AND PROBES FOR MEDICAL PURPOSES (U.S. CLS. 26, 39 AND 44).

CLASS 12—VEHICLES

FOR NON-ELECTRIC MOTORS FOR RAILWAY ROLLING STOCKS; NON-ELECTRIC MOTORS FOR BICYCLES; NON-ELECTRIC MOTORS FOR ELECTRIC AUTOMOBILES; NON-ELECTRIC MOTORS FOR LAND VEHICLES; AC MOTORS AND DC MOTORS FOR LINEAR-MOTOR RAILWAY ROLLING STOCKS, LINEAR-MOTOR ELECTRIC AUTOMOBILES AND LINEAR-MOTOR HYBRID ELECTRIC AUTOMOBILES; AC MOTORS AND DC MOTORS FOR LAND VEHICLES; POWER STEERING UNITS USING PERMANENT MAGNETS FOR AUTOMOBILES; BRAKES USING PERMANENT MAGNETS FOR AUTOMOBILES; TRANSMISSION COMPONENTS, NAMELY, MAGNETIC COUPLINGS FOR NON-CONTACT TRANSMISSION OF ROTARY TORQUE FOR LAND VEHICLES; TRANSMISSION MECHANISMS FOR LAND VEHICLES (U.S. CLS. 19, 21, 23, 31, 35 AND 44).

CLASS 16—PAPER GOODS AND PRINTED MATTER

FOR FIGURINES AND STATUETTES MADE OF PAPER AND MAGNETS; PRINTED MATTER IN THE NATURE OF CALENDARS, CATALOGS, BOOKS AND PAMPHLETS IN THE FIELDS OF MAGNETIC MATERIALS AND EQUIPMENT, CERAMICS AND MATERIALS FOR ELECTRONIC EQUIPMENT (U.S. CLS. 2, 5, 22, 23, 29, 37, 38 AND 50).

STEVEN JACKSON, EXAMINING ATTORNEY

SN 79-094,610. HITACHI KINZOKU KABUSHIKI KAISHA (HITACHI METALS, LTD.), JAPAN, FILED 1-28-2011.

NEOMAX MATERIALS

THE MARK CONSISTS OF STANDARD CHARACTERS WITHOUT CLAIM TO ANY PARTICULAR FONT, STYLE, SIZE, OR COLOR.

PRIORITY DATE OF 12-13-2010 IS CLAIMED. OWNER OF INTERNATIONAL REGISTRATION 1069812 DATED 1-28-2011, EXPIRES 1-28-2021.

OWNER OF U.S. REG. NOS. 3,078,642, 3,094,983 AND OTHERS.

NO CLAIM IS MADE TO THE EXCLUSIVE RIGHT TO USE "MATERIALS", APART FROM THE MARK AS SHOWN.

CLASS 6—METAL GOODS

FOR CLAD METALS CONSISTING OF PRESSURE-WELDED STAINLESS STEELS, OTHER IRON AND STEELS, AND NONFERROUS METALS AND THEIR ALLOYS; IRONS AND STEELS; CLAD METALS CONSISTING OF PRESSURE-WELDED NICKEL ALLOYS, COPPER ALLOYS, CHROME ALLOYS, TITANIUM ALLOYS, AND OTHER NONFERROUS METALS AND THEIR ALLOYS; BRAZING FILLER METALS; BRAZING ALLOYS; SOLDER-COATED COPPER BALLS; NONFERROUS METALS AND THEIR ALLOYS; COMMON METALS, UNWROUGHT OR SEMI-WROUGHT; WIRE OF COMMON METAL; PIPES OF COMMON METAL; WIRE OF COMMON METAL ALLOYS, EXCEPT FUSE WIRE; PIPES OF COMMON METAL ALLOYS (U.S. CLS. 2, 12, 13, 14, 23, 25 AND 50).

CLASS 9—ELECTRICAL AND SCIENTIFIC APPARATUS

FOR MEASURING OR TESTING MACHINES, INSTRUMENTS AND THEIR PARTS, NAMELY, RESISTORS, BIMETALS FOR TEMPERATURE CONTROL; POWER DISTRIBUTION OR CONTROL MACHINES, APPARATUS AND THEIR PARTS, NAMELY, BIMETALS FOR CIRCUIT BREAKERS, LAMINATED IRON CORES FOR EARTH LEAKAGE BREAKERS; FUEL CELLS AND THEIR PARTS, NAMELY, INTER-CONNECTORS, SEPARATORS; PHOTOVOLTAIC CELLS AND MODULES AND THEIR PARTS, NAMELY, INTER-CONNECTORS, BUS BARS; BATTERIES, CELLS AND THEIR PARTS, NAMELY, INNER/OUTER LEADS, SEPARATORS, BUS BARS, TERMINALS; ELECTRIC WIRES AND CABLES; TELECOMMUNICATION MACHINES, APPARATUS AND THEIR PARTS, NAMELY, LIDS, SEAL RINGS AND LEAD PINS FOR PACKAGES FOR IC CHIPS, FREQUENCY FILTERS AND CRYSTAL OSCILLATORS; COLD CATHODE FLUORESCENT LAMPS AND THEIR PARTS, NAMELY, LEADS AND ELECTRODES; CATHODE FOR CATHODE-RAY TUBES; ANODE BUTTONS FOR CATHODE-RAY TUBES; STUD PINS FOR CATHODE-RAY TUBES; ELECTRONIC MACHINES, APPARATUS AND THEIR PARTS, NAMELY, TORQUE SENSORS AND CURRENT SENSORS; MAGNETIC CORES; RESISTANCE WIRES; ELECTRODES (U.S. CLS. 21, 23, 26, 36 AND 38).

CLASS 14—JEWELRY

FOR PRECIOUS METALS AND THEIR ALLOYS; CLOCKS, WATCHES AND WATCH PARTS (U.S. CLS. 2, 27, 28 AND 50).

CLASS 40—MATERIAL TREATMENT

FOR METAL TREATMENT (U.S. CLS. 100, 103 AND 106).

STEVEN JACKSON, EXAMINING ATTORNEY

SN 79-094,790. ZENTRUM MIKROELEKTRONIK DRESDEN AG, DRESDEN, FED REP GERMANY, FILED 12-14-2010.

Pink Puma

THE MARK CONSISTS OF STANDARD CHARACTERS WITHOUT CLAIM TO ANY PARTICULAR FONT, STYLE, SIZE, OR COLOR.

PRIORITY DATE OF 11-11-2010 IS CLAIMED. OWNER OF INTERNATIONAL REGISTRATION 1070246 DATED 12-14-2010, EXPIRES 12-14-2020.

CLASS 9—ELECTRICAL AND SCIENTIFIC APPARATUS

FOR INTEGRATED CIRCUITS, NAMELY, METAL-OXIDE-SEMICONDUCTOR (MOS) CIRCUITS; MULTI-CHIP INTEGRATED CIRCUIT MODULES; ELECTRIC AND/OR ELECTRONIC SENSORS FOR LIGHT INTENSITY, ACCELERATION, COMPRESSION, PRESSURE, AND DISTANCE; MICROSYSTEMS, NAMELY, APPLICATION-SPECIFIC INTEGRATED CIRCUITS (ASICS); INTEGRATED CIRCUITS IN THE NATURE OF APPLICATION-SPECIFIC STANDARD ELECTRONIC PRODUCTS (ASSPS); POWER ELECTRONICS INTEGRATED CIRCUITS; POWER CONTROL, POWER CONTROL MODULES, ELECTRIC CONTROLLING MODULES FOR MANAGING POWER SUPPLY, AND ELECTRIC POWER CONVERSION MODULES (U.S. CLS. 21, 23, 26, 36 AND 38).

CLASS 42—SCIENTIFIC AND COMPUTER SERVICES

FOR DESIGN AND DEVELOPMENT OF METAL-OXIDE-SEMICONDUCTOR (MOS) CIRCUITS, MULTI-CHIP INTEGRATED CIRCUIT MODULES, ELECTRIC AND/OR ELECTRONIC SENSORS FOR LIGHT INTENSITY, ACCELERATION, COMPRESSION, PRESSURE, AND DISTANCE; MICROSYSTEMS CONSISTING PRIMARILY OF MICRO-PROCESSORS AND MICRO-COMPUTERS, CUSTOMIZED INTEGRATED CIRCUITS IN THE NATURE OF APPLICATION-SPECIFIC INTEGRATED CIRCUITS (ASICS), INTEGRATED CIRCUITS IN THE NATURE OF APPLICATION-SPECIFIC STANDARD ELECTRONIC PRODUCTS (ASSPS), POWER ELECTRONICS INTEGRATED CIRCUITS, POWER CONTROL, POWER CONTROL MODULES, ELECTRIC CONTROLLING MODULES FOR MANAGING POWER SUPPLY, AND ELECTRIC POWER CONVERSION MODULES (U.S. CLS. 100 AND 101).

JEAN IM, EXAMINING ATTORNEY

SN 79-094,792. PEERLESS INDUSTRIAL SYSTEMS PTY LTD, HIGHETT, AUSTRALIA, FILED 11-1-2010.

EPIGEN

THE MARK CONSISTS OF STANDARD CHARACTERS WITHOUT CLAIM TO ANY PARTICULAR FONT, STYLE, SIZE, OR COLOR.

OWNER OF INTERNATIONAL REGISTRATION 1070250 DATED 11-1-2010, EXPIRES 11-1-2020.

CLASS 1—CHEMICALS

FOR EPOXY RESINS; ADHESIVES, NAMELY, ADHESIVES FOR INDUSTRIAL USE; INDUSTRIAL CHEMICALS; WATERPROOFING CHEMICALS; ELASTOMERIC AND POLYMER COMPOUNDS, NAMELY, UNPROCESSED ELASTOMERIC AND POLYMERIC RESINS FOR INDUSTRIAL USE; GROUTS BEING UNPROCESSED REACTIVE SYNTHETIC RESINS NOT FOR BUILDING PURPOSES; ALL OF THE AFORESAID GOODS EXCLUDING SURFACTANTS (U.S. CLS. 1, 5, 6, 10, 26 AND 46).

CLASS 2—PAINTS

FOR REPAIR COMPOUNDS, NAMELY, RESIN BASED COATINGS AND PROTECTIVE COATINGS AND PAINT ALL FOR PROTECTION FROM ABRASION, CHEMICAL, THERMAL AND ENVIRONMENTAL ATTACK; REPAIR COMPOUNDS, NAMELY, RESIN BASED COATINGS AND PROTECTIVE COATINGS AND PAINT ALL FOR STRUCTURES, PLANT AND EQUIPMENT, INCLUDING FLOORING, MACHINERY AND TANKS, BOTH LAND AND MARINE BASED (U.S. CLS. 6, 11 AND 16).

APRIL ROACH, EXAMINING ATTORNEY

SN 79-094,827. ZENTRUM MIKROELEKTRONIK DRESDEN AG, DRESDEN, FED REP GERMANY, FILED 12-14-2010.

Pink Power Designer

THE MARK CONSISTS OF STANDARD CHARACTERS WITHOUT CLAIM TO ANY PARTICULAR FONT, STYLE, SIZE, OR COLOR.

PRIORITY DATE OF 11-11-2010 IS CLAIMED.

OWNER OF INTERNATIONAL REGISTRATION 1070363 DATED 12-14-2010, EXPIRES 12-14-2020.

OWNER OF U.S. REG. NOS. 3,817,183 AND 3,889,360.

NO CLAIM IS MADE TO THE EXCLUSIVE RIGHT TO USE "POWER" AND "DESIGNER", APART FROM THE MARK AS SHOWN.

CLASS 9—ELECTRICAL AND SCIENTIFIC APPARATUS

FOR INTEGRATED CIRCUITS, NAMELY, METAL-OXIDE-SEMICONDUCTOR (MOS) CIRCUITS; MULTI-CHIP INTEGRATED CIRCUIT MODULES; ELECTRIC AND/OR ELECTRONIC SENSORS FOR LIGHT INTENSITY, ACCELERATION, COMPRESSION, PRESSURE, AND DISTANCE; MICROSYSTEMS, NAMELY, APPLICATION-SPECIFIC INTEGRATED CIRCUITS (ASICS); INTEGRATED CIRCUITS IN THE NATURE OF APPLICATION-SPECIFIC STANDARD ELECTRONIC PRODUCTS (ASSPS); POWER ELECTRONICS INTEGRATED CIRCUITS; POWER CONTROL, POWER CONTROL MODULES, ELECTRIC CONTROLLING MODULES FOR MANAGING POWER SUPPLY, AND ELECTRIC POWER CONVERSION MODULES (U.S. CLS. 21, 23, 26, 36 AND 38).

CLASS 42—SCIENTIFIC AND COMPUTER SERVICES

FOR DESIGN AND DEVELOPMENT OF METAL-OXIDE-SEMICONDUCTOR (MOS) CIRCUITS, MULTI-CHIP INTEGRATED CIRCUIT MODULES, ELECTRIC AND/OR ELECTRONIC SENSORS FOR LIGHT INTENSITY, ACCELERATION, COMPRESSION, PRESSURE, AND DISTANCE; MICROSYSTEMS CONSISTING PRIMARILY OF MICRO-PROCESSORS AND MICRO-COMPUTERS, CUSTOMIZED INTEGRATED CIRCUITS IN THE NATURE OF APPLICATION-SPECIFIC INTEGRATED CIRCUITS (ASICS), INTEGRATED CIRCUITS IN THE NATURE OF APPLICATION-SPECIFIC STANDARD ELECTRONIC PRODUCTS (ASSPS), POWER ELECTRONICS INTEGRATED CIRCUITS, POWER CONTROL, POWER CONTROL MODULES, ELECTRIC CONTROLLING MODULES FOR MANAGING POWER SUPPLY, AND ELECTRIC POWER CONVERSION MODULES (U.S. CLS. 100 AND 101).

JEAN IM, EXAMINING ATTORNEY

SN 79-094,997. CAROLINE FROMELL, VÄSTERÅS, SWEDEN, FILED 1-21-2011.



BABY ELEPHANT

PRIORITY DATE OF 7-28-2010 IS CLAIMED.

OWNER OF INTERNATIONAL REGISTRATION 1070797 DATED 1-21-2011, EXPIRES 1-21-2021.

NO CLAIM IS MADE TO THE EXCLUSIVE RIGHT TO USE "BABY", APART FROM THE MARK AS SHOWN.

THE MARK CONSISTS OF THE WORDING "BABY ELEPHANT" WITH A STYLIZED REPRESENTATION OF AN ELEPHANT'S HEAD.

CLASS 26—FANCY GOODS

FOR WALKING REINS AND WALKING HARNESS FOR CHILDREN (U.S. CLS. 37, 39, 40, 42 AND 50).

CLASS 35—ADVERTISING AND BUSINESS

FOR RETAIL STORE SERVICES, WHOLESALE STORE SERVICES, AND ONLINE RETAIL STORE SERVICES FEATURING WALKING REINS AND WALKING HARNESSES FOR CHILDREN (U.S. CLS. 100, 101 AND 102).

MICHELLE DUBOIS, EXAMINING ATTORNEY

SN 79-095,306. Q-MATIC AB, SWEDEN, FILED 2-15-2011.

QMATIC

PRIORITY DATE OF 10-5-2010 IS CLAIMED.
OWNER OF INTERNATIONAL REGISTRATION 1071785
DATED 2-15-2011, EXPIRES 2-15-2021.

OWNER OF U.S. REG. NOS. 1,591,766, 1,715,202 AND
3,440,880.

THE MARK CONSISTS OF THE WORDING "QMATIC" IN
A STYLIZED FONT.

CLASS 9—ELECTRICAL AND SCIENTIFIC APPARATUS

FOR COMPUTER SOFTWARE FOR QUEUE MAN-
AGEMENT AND CUSTOMER FLOW MANAGEMENT,
AND CONNECTED COMPUTERS, INCLUDING CON-
NECTED PARTS AND ACCESSORIES, NAMELY, PRIN-
TERS, TERMINALS, SCREENS AND CARD SENSORS
(U.S. CLS. 21, 23, 26, 36 AND 38).

CLASS 16—PAPER GOODS AND PRINTED MATTER

FOR QUEUE AND PRIORITY TICKETS MADE OF
PAPER, ALSO SUCH AS BANDS OR ROLLS (U.S. CLS. 2,
5, 22, 23, 29, 37, 38 AND 50).

ALLISON SCHRODY, EXAMINING ATTORNEY

SN 79-095,322. POWERWIND GMBH, FED REP GERMANY,
FILED 1-18-2011.

PowerWind

THE MARK CONSISTS OF STANDARD CHARACTERS
WITHOUT CLAIM TO ANY PARTICULAR FONT, STYLE,
SIZE, OR COLOR.

OWNER OF INTERNATIONAL REGISTRATION 1071824
DATED 1-18-2011, EXPIRES 1-18-2021.

CLASS 7—MACHINERY

FOR WIND POWERED ELECTRICITY GENERATION
SYSTEMS COMPRISED PRIMARILY OF WIND POW-
ERED ELECTRICITY GENERATORS, GEARBOXES,
GENERATORS, MOTORS, TURBINES, ROTORS AND
ROTOR BLADES, AND REPLACEMENT PARTS THERE-
FORE (U.S. CLS. 13, 19, 21, 23, 31, 34 AND 35).

CLASS 9—ELECTRICAL AND SCIENTIFIC APPARATUS

FOR ELECTRICAL AND ELECTRONIC APPARATUS
AND INSTRUMENTS FOR USE IN ENERGY GENERAT-
ING PLANTS, AS FAR AS INCLUDED IN THIS CLASS,
NAMELY, ELECTRIC SWITCHES, FREQUENCY CON-
VERTERS, MEASURING AND SIGNALING AND
CHECKING INSTRUMENTS, NAMELY, SCALES AND
SIGNAL WHISTLES; COMPUTERS AND COMPUTER
SOFTWARE FOR MONITORING AND CONTROLLING
WIND STATIONS AND WIND ENERGY PLANTS; SO-
LAR CELLS FOR ELECTRICITY GENERATION (U.S.
CLS. 21, 23, 26, 36 AND 38).

CLASS 37—CONSTRUCTION AND REPAIR

FOR INSTALLATION, MAINTENANCE AND REPAIR
OF WIND STATIONS AND WIND ENERGY PLANTS
(U.S. CLS. 100, 103 AND 106).

CLASS 42—SCIENTIFIC AND COMPUTER SERVICES

FOR DEVELOPMENT OF WIND STATIONS AND
WIND ENERGY PLANTS, WIND TURBINES, WIND-
OPERATED MACHINES AND THEIR COMPONENTS,
NAMELY, PROVIDING ENGINEERING SERVICES;
TECHNOLOGICAL CONSULTANCY FOR WIND STA-
TIONS, NAMELY, ENGINEERING SERVICES; ENGI-
NEERING AND SCIENTIFIC SURVEYS FOR THE
CONSTRUCTION AND OPERATING OF WIND EN-
ERGY PLANTS; RESEARCH, DEVELOPMENT, TECHNI-
CAL CONSULTANCY AND ENVIRONMENTAL
PROTECTION CONSULTANCY IN THE FIELD OF RE-
NEWABLE ENERGY PRODUCTIONS; DESIGN AND
DEVELOPMENT OF COMPUTER SOFTWARE FOR
CONTROLLING WIND ENERGY PLANTS AND FOR
NETWORK FEEDING (U.S. CLS. 100 AND 101).

SEAN CROWLEY, EXAMINING ATTORNEY

SN 79-095,465. GEA BREWERY SYSTEMS GMBH, FED REP
GERMANY, FILED 10-29-2010.

ECOPITCH

THE MARK CONSISTS OF STANDARD CHARACTERS
WITHOUT CLAIM TO ANY PARTICULAR FONT, STYLE,
SIZE, OR COLOR.

PRIORITY DATE OF 6-2-2010 IS CLAIMED.

OWNER OF INTERNATIONAL REGISTRATION 1072216
DATED 10-29-2010, EXPIRES 10-29-2020.

CLASS 6—METAL GOODS

FOR SETTLING VATS OF METAL; CONTAINERS OF
METAL USED AS VATS OR PRESSURE TANKS, ALSO
FITTED WITH REGULATING MECHANISMS IN PAR-
TICULAR FOR PRESSURE, TEMPERATURE OR FOR
PUMPS TO PROMOTE THE FLOW OF THE CONTENTS
OF THE CONTAINER; TANKS AND CONTAINERS OF
METAL, IN PARTICULAR YEAST TANKS, YEAST
STORAGE TANKS, FERMENTATION TANKS, PRES-
SURIZED FERMENTATION TANKS, BUFFER TANKS,
CONTAINERS FOR MIXING PURPOSES AND SURGE
TANKS; FERMENTING CELLARS MAINLY CONSIST-
ING OF TANKS MADE OF METAL (U.S. CLS. 2, 12, 13,
14, 23, 25 AND 50).

CLASS 7—MACHINERY

FOR MACHINES AND MACHINERY INSTALLATIONS FOR THE MANUFACTURE, TREATING, PROCESSING AND REFINING OF FOODSTUFFS AND LUXURY FOODSTUFFS AND OF BEVERAGES AND FRUIT JUICES, IN PARTICULAR FOR MIXING, STORING AND PURIFYING, MACHINES AND MACHINERY INSTALLATIONS FOR THE FOOD, BREWING AND DRINKS INDUSTRIES, NAMELY, MACHINES FOR BREWING BEVERAGES AND FOR AUTOMATED WORT AND FERMENTING LINES FOR PRODUCING YEAST CULTURES MAINLY CONSISTING OF TANKS, PIPELINES, VALVES, PUMPS, NAMELY, YEAST PROPAGATION PUMPS; MACHINES FOR TREATMENT, PROCESSING AND FINISHING, NAMELY, FOR THE MIXING, STORAGE AND PURIFYING OF MILK AND MILK PRODUCTS; PUMPS AND JET PUMPS, NAMELY, ROTARY PUMPS, BOX PUMPS, PISTON PUMPS, LIQUID PUMPS, CIRCULATION PUMPS, FEED PUMPS; HAND-OPERATED AND MECHANICALLY OPERATED VALVES BEING MACHINE PARTS; MACHINES FOR TREATING LIQUIDS AND FLUIDS, NAMELY, BEVERAGE PREPARATION MACHINES, ELECTROMECHANICAL AND FERMENTATION CELLARS; PROCESSING INSTALLATIONS FOR FOODSTUFFS AND DRINKS, NAMELY, TANK STORAGE SYSTEMS CONNECTED WITH PIPE SYSTEMS, MAINLY CONSISTING OF PIPELINES, VALVES, PUMPS AND MEASURING, CONTROL AND REGULATING DEVICES; MACHINE PARTS, NAMELY, VALVES AND TAPS AS PARTS OF APPARATUS AND MACHINES FOR THE MANUFACTURE OF DRINKS, NAMELY, HAND-OPERATED AND REMOTE-CONTROLLED DISPOSABLE AND MULTI-USE, SHUT-OFF, BY-PASS AND MIXING VALVES, SLIDE VALVES, NON-RETURN VALVES, AND TAPS FOR LIQUIDS OR GASES; MACHINES, APPARATUS AND MECHANICAL EQUIPMENT, NAMELY, WHIRLPOOLS AND WORT-COOLER FOR THE BREWING AND DRINKS INDUSTRY (U.S. CLS. 13, 19, 21, 23, 31, 34 AND 35).

CLASS 11—ENVIRONMENTAL CONTROL APPARATUS

FOR MACHINES, APPARATUS AND MECHANICAL EQUIPMENT FOR THE MANUFACTURE, TREATING, PROCESSING AND REFINING OF FOODSTUFFS AND LUXURY ITEMS, AND OF LIQUIDS, BEVERAGES AND FRUIT JUICES, NAMELY, FOR HEAT TREATMENT, HEATING, SUPERHEATING, PASTEURIZATION, REFRIGERATION, FREEZING, AND INSTALLATIONS CONSISTING ENTIRELY OR MAINLY OF THE AFORESAID MACHINES, APPARATUS AND EQUIPMENT; REFRIGERATION INSTALLATIONS; HEAT EXCHANGERS, NAMELY, PLATE HEAT EXCHANGERS, TUBULAR HEAT EXCHANGERS, HEATING JACKETS, HEATING TUBE BUNDLES, HEATING COILS, TUBULAR EVAPORATORS, PLATE HEATERS, SPIRAL HEAT EXCHANGERS, PLATE EVAPORATORS; APPARATUS AND MACHINES FOR THE ENTIRE FOOD AND DRINKS INDUSTRY, NAMELY, PASTEURIZATION MACHINES AND APPARATUS, STERILIZING APPARATUS AND MACHINES, HEAT RECOVERING EQUIPMENT IN THE NATURE OF HEAT ACCUMULATORS FOR UTILIZING THE WASTE HEAT FROM COOLING OPERATIONS; HEAT PUMPS; PLATE HEAT EXCHANGERS NOT BEING PARTS OF MACHINES; WATER FILTERING MACHINES AND INSTALLATIONS (U.S. CLS. 13, 21, 23, 31 AND 34).

KRISTINA MORRIS, EXAMINING ATTORNEY

SN 79-096,009. MOLLIFICIO APUANO S.R.L., ITALY, FILED 2-14-2011.



OWNER OF INTERNATIONAL REGISTRATION 1073580 DATED 2-14-2011, EXPIRES 2-14-2021.

NO CLAIM IS MADE TO THE EXCLUSIVE RIGHT TO USE "MOLLIFICIO" AND "SRL", APART FROM THE MARK AS SHOWN.

THE COLOR(S) GREEN AND RED IS/ARE CLAIMED AS A FEATURE OF THE MARK.

RED: BORDER LINE; GREEN: BACKGROUND.

THE MARK CONSISTS OF THE FOLLOWING: A RED-HEDGED RHOMB CONTAINING THE WORDING "MOLLIFICIO APUANO SRL" IN GREEN AND A GREEN RHOMB CONTAINING A TRANSPARENT SPRING INSIDE IT WITH THE COLOR WHITE REPRESENTING BACKGROUND AND TRANSPARENT AREAS AND IS NOT PART OF THE MARK.

THE ENGLISH TRANSLATION OF THE FOREIGN WORD(S) IN THE MARK IS: APUAN SPRING MANUFACTURER.

CLASS 6—METAL GOODS

FOR METAL SPRINGS; STEEL FOR SPRINGS (U.S. CLS. 2, 12, 13, 14, 23, 25 AND 50).

CLASS 8—HAND TOOLS

FOR SPRING TOOLS, NAMELY, MANUALLY OPERATED HAND TOOLS FOR PULLING, PUSHING, INSERTING OBJECTS (U.S. CLS. 23, 28 AND 44).

WON TEAK OH, EXAMINING ATTORNEY

SN 79-096,238. DANISCO A/S, DENMARK, FILED 3-10-2011.

Lr-32

THE MARK CONSISTS OF STANDARD CHARACTERS WITHOUT CLAIM TO ANY PARTICULAR FONT, STYLE, SIZE, OR COLOR.

OWNER OF INTERNATIONAL REGISTRATION 1074089 DATED 3-10-2011, EXPIRES 3-10-2021.

THE WORDING "LR-32" HAS NO MEANING IN A FOREIGN LANGUAGE.

CLASS 1—CHEMICALS

FOR INGREDIENTS FOR INDUSTRIAL MANUFACTURE OF FOODSTUFFS AND BEVERAGES FOR BOTH HUMAN AND ANIMAL CONSUMPTION, NAMELY, CULTURES OF MICROORGANISMS, NOT FOR MEDICAL OR VETERINARY PURPOSES (U.S. CLS. 1, 5, 6, 10, 26 AND 46).

CLASS 5—PHARMACEUTICALS

FOR CULTURES OF MICROORGANISMS FOR USE IN PHARMACEUTICAL AND VETERINARY PREPARATIONS, INFANT AND TODDLER FORMULAS; DIETARY SUPPLEMENTS FOR MEDICAL USE (U.S. CLS. 6, 18, 44, 46, 51 AND 52).

TAMARA FRAZIER, EXAMINING ATTORNEY

CLASS 1—CHEMICALS

FOR INGREDIENTS FOR INDUSTRIAL MANUFACTURE OF FOODSTUFFS AND BEVERAGES FOR BOTH HUMAN AND ANIMAL CONSUMPTION, NAMELY, CULTURES OF MICROORGANISMS, NOT FOR MEDICAL OR VETERINARY PURPOSES (U.S. CLS. 1, 5, 6, 10, 26 AND 46).

CLASS 5—PHARMACEUTICALS

FOR CULTURES OF MICROORGANISMS FOR USE IN PHARMACEUTICAL AND VETERINARY PREPARATIONS, INFANT AND TODDLER FORMULAS; DIETARY SUPPLEMENTS FOR MEDICAL USE (U.S. CLS. 6, 18, 44, 46, 51 AND 52).

TAMARA FRAZIER, EXAMINING ATTORNEY

SN 79-096,323. DANISCO A/S, DENMARK, FILED 3-10-2011.

Lp-115

THE MARK CONSISTS OF STANDARD CHARACTERS WITHOUT CLAIM TO ANY PARTICULAR FONT, STYLE, SIZE, OR COLOR.

OWNER OF INTERNATIONAL REGISTRATION 1074289 DATED 3-10-2011, EXPIRES 3-10-2021.

THE WORDING "LP-115" HAS NO MEANING IN A FOREIGN LANGUAGE.

CLASS 1—CHEMICALS

FOR INGREDIENTS FOR INDUSTRIAL MANUFACTURE OF FOODSTUFFS AND BEVERAGES FOR BOTH HUMAN AND ANIMAL CONSUMPTION, NAMELY, CULTURES OF MICROORGANISMS, NOT FOR MEDICAL OR VETERINARY PURPOSES (U.S. CLS. 1, 5, 6, 10, 26 AND 46).

CLASS 5—PHARMACEUTICALS

FOR CULTURES OF MICROORGANISMS FOR USE IN PHARMACEUTICAL AND VETERINARY PREPARATIONS, INFANT AND TODDLER FORMULAS; DIETARY SUPPLEMENTS FOR MEDICAL USE (U.S. CLS. 6, 18, 44, 46, 51 AND 52).

TAMARA FRAZIER, EXAMINING ATTORNEY

SN 79-096,376. DANISCO A/S, DENMARK, FILED 3-10-2011.

Lpc-37

THE MARK CONSISTS OF STANDARD CHARACTERS WITHOUT CLAIM TO ANY PARTICULAR FONT, STYLE, SIZE, OR COLOR.

OWNER OF INTERNATIONAL REGISTRATION 1074389 DATED 3-10-2011, EXPIRES 3-10-2021.

THE WORDING "LPC-37" HAS NO MEANING IN A FOREIGN LANGUAGE.

SN 79-096,377. DANISCO A/S, DENMARK, FILED 3-10-2011.

BI-04

THE MARK CONSISTS OF STANDARD CHARACTERS WITHOUT CLAIM TO ANY PARTICULAR FONT, STYLE, SIZE, OR COLOR.

OWNER OF INTERNATIONAL REGISTRATION 1074390 DATED 3-10-2011, EXPIRES 3-10-2021.

THE WORDING "BI-04" HAS NO MEANING IN A FOREIGN LANGUAGE.

CLASS 1—CHEMICALS

FOR INGREDIENTS FOR INDUSTRIAL MANUFACTURE OF FOODSTUFFS AND BEVERAGES FOR BOTH HUMAN AND ANIMAL CONSUMPTION, NAMELY, CULTURES OF MICROORGANISMS, NOT FOR MEDICAL OR VETERINARY PURPOSES (U.S. CLS. 1, 5, 6, 10, 26 AND 46).

CLASS 5—PHARMACEUTICALS

FOR CULTURES OF MICROORGANISMS FOR USE IN PHARMACEUTICAL AND VETERINARY PREPARATIONS, INFANT AND TODDLER FORMULAS; DIETARY SUPPLEMENTS FOR MEDICAL USE (U.S. CLS. 6, 18, 44, 46, 51 AND 52).

TAMARA FRAZIER, EXAMINING ATTORNEY

SN 79-096,556. DANISCO A/S, DENMARK, FILED 3-10-2011.

La-14

THE MARK CONSISTS OF STANDARD CHARACTERS WITHOUT CLAIM TO ANY PARTICULAR FONT, STYLE, SIZE, OR COLOR.

OWNER OF INTERNATIONAL REGISTRATION 1074856 DATED 3-10-2011, EXPIRES 3-10-2021.

THE WORDING "LA-14" HAS NO MEANING IN A FOREIGN LANGUAGE.

CLASS 1—CHEMICALS

FOR INGREDIENTS FOR INDUSTRIAL MANUFACTURE OF FOODSTUFFS AND BEVERAGES FOR BOTH HUMAN AND ANIMAL CONSUMPTION, NAMELY, CULTURES OF MICROORGANISMS, NOT FOR MEDICAL OR VETERINARY PURPOSES (U.S. CLS. 1, 5, 6, 10, 26 AND 46).

CLASS 5—PHARMACEUTICALS

FOR CULTURES OF MICROORGANISMS FOR USE IN PHARMACEUTICAL AND VETERINARY PREPARATIONS, INFANT AND TODDLER FORMULAS; DIETARY SUPPLEMENTS FOR MEDICAL USE (U.S. CLS. 6, 18, 44, 46, 51 AND 52).

TAMARA FRAZIER, EXAMINING ATTORNEY

CLASS 1—CHEMICALS

FOR INGREDIENTS FOR INDUSTRIAL MANUFACTURE OF FOODSTUFFS AND BEVERAGES FOR BOTH HUMAN AND ANIMAL CONSUMPTION, NAMELY, CULTURES OF MICROORGANISMS, NOT FOR MEDICAL OR VETERINARY PURPOSES (U.S. CLS. 1, 5, 6, 10, 26 AND 46).

CLASS 5—PHARMACEUTICALS

FOR CULTURES OF MICROORGANISMS FOR USE IN PHARMACEUTICAL AND VETERINARY PREPARATIONS, INFANT AND TODDLER FORMULAS; DIETARY SUPPLEMENTS FOR MEDICAL USE (U.S. CLS. 6, 18, 44, 46, 51 AND 52).

TAMARA FRAZIER, EXAMINING ATTORNEY

SN 79-096,557. DANISCO A/S, DENMARK, FILED 3-10-2011.

LS-33

THE MARK CONSISTS OF STANDARD CHARACTERS WITHOUT CLAIM TO ANY PARTICULAR FONT, STYLE, SIZE, OR COLOR.

OWNER OF INTERNATIONAL REGISTRATION 1074857 DATED 3-10-2011, EXPIRES 3-10-2021.

THE WORDING "LS-33" HAS NO MEANING IN A FOREIGN LANGUAGE.

CLASS 1—CHEMICALS

FOR INGREDIENTS FOR INDUSTRIAL MANUFACTURE OF FOODSTUFFS AND BEVERAGES FOR BOTH HUMAN AND ANIMAL CONSUMPTION, NAMELY, CULTURES OF MICROORGANISMS, NOT FOR MEDICAL OR VETERINARY PURPOSES (U.S. CLS. 1, 5, 6, 10, 26 AND 46).

CLASS 5—PHARMACEUTICALS

FOR CULTURES OF MICROORGANISMS FOR USE IN PHARMACEUTICAL AND VETERINARY PREPARATIONS, INFANT AND TODDLER FORMULAS; DIETARY SUPPLEMENTS FOR MEDICAL USE (U.S. CLS. 6, 18, 44, 46, 51 AND 52).

TAMARA FRAZIER, EXAMINING ATTORNEY

SN 79-096,988. DANISCO A/S, DENMARK, FILED 3-10-2011.

LC-11

THE MARK CONSISTS OF STANDARD CHARACTERS WITHOUT CLAIM TO ANY PARTICULAR FONT, STYLE, SIZE, OR COLOR.

OWNER OF INTERNATIONAL REGISTRATION 1076022 DATED 3-10-2011, EXPIRES 3-10-2021.

THE WORDING "LC-11" HAS NO MEANING IN A FOREIGN LANGUAGE.

CLASS 1—CHEMICALS

FOR INGREDIENTS FOR INDUSTRIAL MANUFACTURE OF FOODSTUFFS AND BEVERAGES FOR BOTH HUMAN AND ANIMAL CONSUMPTION, NAMELY, CULTURES OF MICROORGANISMS, NOT FOR MEDICAL OR VETERINARY PURPOSES (U.S. CLS. 1, 5, 6, 10, 26 AND 46).

CLASS 5—PHARMACEUTICALS

FOR CULTURES OF MICROORGANISMS FOR USE IN PHARMACEUTICAL AND VETERINARY PREPARATIONS, INFANT AND TODDLER FORMULAS; DIETARY SUPPLEMENTS FOR MEDICAL USE (U.S. CLS. 6, 18, 44, 46, 51 AND 52).

TAMARA FRAZIER, EXAMINING ATTORNEY

SN 79-096,558. DANISCO A/S, DENMARK, FILED 3-10-2011.

Bi-07

THE MARK CONSISTS OF STANDARD CHARACTERS WITHOUT CLAIM TO ANY PARTICULAR FONT, STYLE, SIZE, OR COLOR.

OWNER OF INTERNATIONAL REGISTRATION 1074858 DATED 3-10-2011, EXPIRES 3-10-2021.

THE WORDING "BI-07" HAS NO MEANING IN A FOREIGN LANGUAGE.

SN 79-098,237. KONINKLIJKE PHILIPS ELECTRONICS N.V., NETHERLANDS, FILED 5-30-2011.

RIGHTFIT

THE MARK CONSISTS OF STANDARD CHARACTERS WITHOUT CLAIM TO ANY PARTICULAR FONT, STYLE, SIZE, OR COLOR.

PRIORITY DATE OF 12-8-2010 IS CLAIMED.
OWNER OF INTERNATIONAL REGISTRATION 1079616 DATED 5-30-2011, EXPIRES 5-30-2021.

CLASS 10—MEDICAL APPARATUS

FOR MEDICAL IMAGING APPARATUS (U.S. CLS. 26, 39 AND 44).

CLASS 37—CONSTRUCTION AND REPAIR

FOR MAINTENANCE AND REPAIR OF MEDICAL IMAGING APPARATUS (U.S. CLS. 100, 103 AND 106).
JANICE L. MCMORROW, EXAMINING ATTORNEY

SN 79-098,511. LG ELECTRONICS INC., REPUBLIC OF KOREA, FILED 3-15-2011.

Multi X

PRIORITY DATE OF 2-14-2011 IS CLAIMED.
OWNER OF INTERNATIONAL REGISTRATION 1080241
DATED 3-15-2011, EXPIRES 10-11-2021.

CLASS 9—ELECTRICAL AND SCIENTIFIC APPARATUS

FOR POWER CONVERTERS USED IN NEW RENEWABLE ENERGY SYSTEM INCLUDING PHOTOVOLTAIC POWER GENERATION AND WIND POWER; INVERTERS USED IN NEW RENEWABLE ENERGY SYSTEM INCLUDING PHOTOVOLTAIC POWER GENERATION AND WIND POWER; SOLAR BATTERIES; CHARGERS USED IN NEW RENEWABLE ENERGY SYSTEM INCLUDING PHOTOVOLTAIC POWER GENERATION AND WIND POWER (U.S. CLS. 21, 23, 26, 36 AND 38).

CLASS 11—ENVIRONMENTAL CONTROL APPARATUS

FOR SOLAR COLLECTORS; SOLAR WATER HEATERS (U.S. CLS. 13, 21, 23, 31 AND 34).

CLASS 19—NON-METALLIC BUILDING MATERIALS

FOR ROOFING INCORPORATING SOLAR CELLS, NOT OF METAL (U.S. CLS. 1, 12, 33 AND 50).
DAVID HOFFMAN, EXAMINING ATTORNEY

SN 79-098,634. STATTI S.R.L., ITALY, FILED 3-21-2011.

BATASARRO

THE MARK CONSISTS OF STANDARD CHARACTERS WITHOUT CLAIM TO ANY PARTICULAR FONT, STYLE, SIZE, OR COLOR.

PRIORITY DATE OF 3-16-2011 IS CLAIMED.
OWNER OF INTERNATIONAL REGISTRATION 1080616
DATED 3-21-2011, EXPIRES 10-17-2021.

CLASS 29—MEATS AND PROCESSED FOODS

FOR MEAT, FISH, POULTRY AND GAME; MEAT EXTRACTS; PRESERVED, DRIED AND COOKED FRUITS AND VEGETABLES; JELLIES, JAMS; COM-POTES; EGGS; MILK; MILK PRODUCTS EXCLUDING ICE CREAM, ICE MILK AND FROZEN YOGURT; EDIBLE OILS AND FATS (U.S. CL. 46).

CLASS 33—WINES AND SPIRITS

FOR ALCOHOLIC BEVERAGES (EXCEPT BEERS); WINES (U.S. CLS. 47 AND 49).
KYLE PEETE, EXAMINING ATTORNEY

SN 79-099,131. UAB "PREWISE", LITHUANIA, FILED 2-18-2011.

EYLEAN

THE MARK CONSISTS OF STANDARD CHARACTERS WITHOUT CLAIM TO ANY PARTICULAR FONT, STYLE, SIZE, OR COLOR.

PRIORITY DATE OF 11-29-2010 IS CLAIMED.
OWNER OF INTERNATIONAL REGISTRATION 1082020
DATED 2-18-2011, EXPIRES 7-6-2021.

CLASS 9—ELECTRICAL AND SCIENTIFIC APPARATUS

FOR SOFTWARE FOR TASK MANAGEMENT, FOR PROCESS AND PROJECT MANAGEMENT, USED BY SOFTWARE DEVELOPERS, IT PROFESSIONALS, SALES, MARKETING, SUPPORT EMPLOYEES, PLANNING, FINANCE, MANUFACTURING DIVISIONS AND ANY OTHER CONSUMERS WHICH CAN BE USED ON COMPUTERS, HANDHELDS, TABLET COMPUTERS, SMART PHONES AND ANY OTHER ELECTRONIC DEVICES; SOFTWARE FOR ELECTRONIC INTERACTIVE WHITEBOARDS CONTROL; ELECTRONIC INTERACTIVE WHITEBOARDS (U.S. CLS. 21, 23, 26, 36 AND 38).

CLASS 42—SCIENTIFIC AND COMPUTER SERVICES

FOR PROVIDING ON-LINE NON-DOWNLOADABLE SOFTWARE FOR TASK MANAGEMENT, PROCESS AND PROJECT MANAGEMENT, USED BY SOFTWARE DEVELOPERS, IT PROFESSIONALS, SALES, MARKETING, SUPPORT EMPLOYEES, PLANNING, FINANCE, MANUFACTURING DIVISIONS AND ANY OTHER CONSUMERS; DATA STORAGE AND BACKUP, SECURITY ASSURANCE, USER SUPPORT, ONLINE CONSULTATION RELATED TO THE DESCRIBED SERVICES (U.S. CLS. 100 AND 101).

CAROLYN CATALDO, EXAMINING ATTORNEY

SN 85-001,090. MARKETING 3000 PLUS INC., SCARBOROUGH, ONTARIO, CANADA, FILED 3-29-2010.

GLACIAL TREASURE

THE MARK CONSISTS OF STANDARD CHARACTERS WITHOUT CLAIM TO ANY PARTICULAR FONT, STYLE, SIZE, OR COLOR.

PRIORITY CLAIMED UNDER SEC. 44(D) ON CANADA APPLICATION NO. 1474221, FILED 3-23-2010, REG. NO. TMA799,486, DATED 6-7-2011, EXPIRES 6-7-2026.

CLASS 29—MEATS AND PROCESSED FOODS

FOR FROZEN CHICKEN PRODUCTS; CHICKEN FINGERS; CHICKEN BREAST; CHICKEN WINGS; CHICKEN TENDERLOINS; WHOLE CHICKEN; PORK, BEEF, LAMB AND CHICKEN PRODUCTS, FRESH AND FROZEN, COOKED AND RAW, SEASONED AND UNSEASONED, SKEWERED AND NON-SKEWERED, PORTIONED AND NON-PORCIONED, AND BREADED AND NON-BREADED; PEPPERONI; SALAMI; BACON; STUFFED CHICKEN BREASTS (U.S. CL. 46).

CLASS 30—STAPLE FOODS

FOR PREPARED SANDWICHES; PREPARED SANDWICHES IN THE NATURE OF WRAPS (U.S. CL. 46).
ROBIN MITTLER, EXAMINING ATTORNEY

SN 85-004,090. GENERAL MOTORS LLC, DETROIT, MI.
FILED 4-1-2010.

ECOLOGIC

THE MARK CONSISTS OF STANDARD CHARACTERS WITHOUT CLAIM TO ANY PARTICULAR FONT, STYLE, SIZE, OR COLOR.

CLASS 7—MACHINERY

FOR AUTOMOTIVE PARTS AND COMPONENTS INCORPORATED INTO A MOTOR LAND VEHICLE DESIGNED TO REDUCE CO2 EMISSIONS AND INCREASE FUEL ECONOMY, NAMELY, AUTOMOBILE EXHAUST SYSTEM COMPONENTS AND PARTS, NAMELY, INTAKE MANIFOLDS, AIR SHUTTERS, AIR INTAKE BAFFLES AND AIR DAMS (U.S. CLS. 13, 19, 21, 23, 31, 34 AND 35).

CLASS 12—VEHICLES

FOR AUTOMOTIVE PARTS AND COMPONENTS INCORPORATED INTO A MOTOR LAND VEHICLE DESIGNED TO REDUCE CO2 EMISSIONS AND INCREASE FUEL ECONOMY, NAMELY, ENGINES, TRANSMISSIONS, SUSPENSION SYSTEMS, DRIVE SHAFT, BRAKES, TIRES, WHEELS, ROCKER ARMS, ELECTRONIC FUEL INJECTION MODULE, SPOILERS, AERODYNAMIC BODY PANELS, AUTOMOBILE GRILLS (U.S. CLS. 19, 21, 23, 31, 35 AND 44).
BARBARA A. GOLD, EXAMINING ATTORNEY

SN 85-006,561. DESTINY HEALTH, INC., CHICAGO, IL.
FILED 4-5-2010.

VEOT

THE MARK CONSISTS OF STANDARD CHARACTERS WITHOUT CLAIM TO ANY PARTICULAR FONT, STYLE, SIZE, OR COLOR.

OWNER OF U.S. REG. NOS. 2,800,989, 3,381,251 AND OTHERS.

CLASS 35—ADVERTISING AND BUSINESS

FOR PROVIDING ASSISTANCE, FITNESS EVALUATION AND CONSULTATION TO BUSINESSES TO HELP THEIR EMPLOYEES MAKE HEALTH, WELLNESS AND NUTRITIONAL CHANGES IN THEIR DAILY LIVING TO INCREASE PRODUCTIVITY AND LOWER HEALTH CARE COSTS (U.S. CLS. 100, 101 AND 102).

CLASS 42—SCIENTIFIC AND COMPUTER SERVICES

FOR APPLICATION SERVICE PROVIDER, NAMELY, PROVIDING, HOSTING, MANAGING, DEVELOPING, RESEARCHING, ANALYZING, REPORTING, AND MAINTAINING APPLICATIONS, SOFTWARE AND DATABASES FOR OTHERS IN THE FIELDS OF EMPLOYEE HEALTH INSURANCE AND WELLNESS PROGRAMS (U.S. CLS. 100 AND 101).

ALYSSA STEEL, EXAMINING ATTORNEY

SN 85-006,567. DESTINY HEALTH, INC., CHICAGO, IL.
FILED 4-5-2010.

VITALITY ENGAGEMENT OPTIMIZATION TOOL

THE MARK CONSISTS OF STANDARD CHARACTERS WITHOUT CLAIM TO ANY PARTICULAR FONT, STYLE, SIZE, OR COLOR.

OWNER OF U.S. REG. NOS. 2,800,989, 3,381,251 AND OTHERS.

NO CLAIM IS MADE TO THE EXCLUSIVE RIGHT TO USE "ENGAGEMENT OPTIMIZATION TOOL", APART FROM THE MARK AS SHOWN.

CLASS 35—ADVERTISING AND BUSINESS

FOR PROVIDING ASSISTANCE, FITNESS EVALUATION AND CONSULTATION TO BUSINESSES TO HELP THEIR EMPLOYEES MAKE HEALTH, WELLNESS AND NUTRITIONAL CHANGES IN THEIR DAILY LIVING TO INCREASE PRODUCTIVITY AND LOWER HEALTH CARE COSTS (U.S. CLS. 100, 101 AND 102).

CLASS 42—SCIENTIFIC AND COMPUTER SERVICES

FOR APPLICATION SERVICE PROVIDER, NAMELY, PROVIDING, HOSTING, MANAGING, DEVELOPING, RESEARCHING, ANALYZING, REPORTING, AND MAINTAINING APPLICATIONS, SOFTWARE AND DATABASES FOR OTHERS IN THE FIELDS OF EMPLOYEE HEALTH INSURANCE AND WELLNESS PROGRAMS (U.S. CLS. 100 AND 101).

ALYSSA STEEL, EXAMINING ATTORNEY

SN 85-006,577. DESTINY HEALTH, INC., CHICAGO, IL.
FILED 4-5-2010.

VITALITY WELLNESS DIAGNOSTIC

THE MARK CONSISTS OF STANDARD CHARACTERS WITHOUT CLAIM TO ANY PARTICULAR FONT, STYLE, SIZE, OR COLOR.

OWNER OF U.S. REG. NOS. 2,800,989, 3,381,251 AND OTHERS.

NO CLAIM IS MADE TO THE EXCLUSIVE RIGHT TO USE "WELLNESS DIAGNOSTIC", APART FROM THE MARK AS SHOWN.

CLASS 35—ADVERTISING AND BUSINESS

FOR PROVIDING ASSISTANCE, FITNESS EVALUATION AND CONSULTATION TO BUSINESSES TO HELP THEIR EMPLOYEES MAKE HEALTH, WELLNESS AND NUTRITIONAL CHANGES IN THEIR DAILY LIVING TO INCREASE PRODUCTIVITY AND LOWER HEALTH CARE COSTS (U.S. CLS. 100, 101 AND 102).

CLASS 42—SCIENTIFIC AND COMPUTER SERVICES

FOR APPLICATION SERVICE PROVIDER, NAMELY, PROVIDING, HOSTING, MANAGING, DEVELOPING, RESEARCHING, ANALYZING, REPORTING, AND MAINTAINING APPLICATIONS, SOFTWARE AND DATABASES FOR OTHERS IN THE FIELDS OF EMPLOYEE HEALTH INSURANCE AND WELLNESS PROGRAMS (U.S. CLS. 100 AND 101).

ALYSSA STEEL, EXAMINING ATTORNEY

SN 85-009,893. SYDROB, INC., BEVERLY HILLS, CA. FILED 4-8-2010.

DR. REY HEALTH

THE MARK CONSISTS OF STANDARD CHARACTERS WITHOUT CLAIM TO ANY PARTICULAR FONT, STYLE, SIZE, OR COLOR.

OWNER OF U.S. REG. NOS. 3,596,736, 3,666,303 AND OTHERS.

NO CLAIM IS MADE TO THE EXCLUSIVE RIGHT TO USE "HEALTH", APART FROM THE MARK AS SHOWN.

THE NAME(S), PORTRAIT(S), AND/OR SIGNATURE(S) SHOWN IN THE MARK IDENTIFIES ROBERT REY, WHOSE CONSENT(S) TO REGISTER IS MADE OF RECORD.

CLASS 3—COSMETICS AND CLEANING PREPARATIONS

FOR COSMETICS, NAMELY, BEAUTY CREAMS, BEAUTY GELS, BEAUTY LOTIONS, BEAUTY MASKS, BEAUTY SERUMS; COSMETIC PREPARATIONS FOR SKIN RENEWAL; COSMETIC CREAMS FOR SKIN CARE (U.S. CLS. 1, 4, 6, 50, 51 AND 52).

CLASS 5—PHARMACEUTICALS

FOR NUTRITIONAL OILS NOT FOR FOOD OR COSMETIC PURPOSES; INGESTIBLE MINERAL SUPPLEMENTS FOR HAIR, SKIN AND NAILS; INGESTIBLE VITAMIN SUPPLEMENTS FOR HAIR, SKIN AND NAILS; INGESTIBLE DIETARY SUPPLEMENTS FOR HAIR, SKIN AND NAILS; MEAL REPLACEMENT INGESTIBLES, NAMELY, DRINKS, DIETARY DRINK MIXES, NUTRITIONAL FOOD BARS, COOKIES, SNACKS, NUTRITIONAL DRINK MIX; DIETARY SUPPLEMENTS FOR HUMAN CONSUMPTION; NUTRITIONAL SUPPLEMENTS FOR HUMAN CONSUMPTION; NUTRACEUTICALS FOR USE AS A DIETARY SUPPLEMENT (U.S. CLS. 6, 18, 44, 46, 51 AND 52).

CLASS 29—MEATS AND PROCESSED FOODS

FOR NUTRITIONAL OILS FOR FOOD PURPOSES; PROCESSED INGESTIBLE WHOLE CHIA SEED FOR HUMAN CONSUMPTION; INGESTIBLE CHIA SEED POWDER FOR HUMAN CONSUMPTION; INGESTIBLE CHIA SEED OIL FOR HUMAN CONSUMPTION (U.S. CL. 46).

CLASS 32—LIGHT BEVERAGES

FOR BEVERAGES, NAMELY, FRUIT JUICES AND ENERGY DRINKS CONTAINING NUTRITIONAL SUPPLEMENTS (U.S. CLS. 45, 46 AND 48).

KIM SAITO, EXAMINING ATTORNEY

SN 85-012,068. ACE CORPORATE EVENTS, NEW YORK, NY. FILED 4-12-2010.



THE MARK CONSISTS OF A SERIES OF ASTERISKS ARRANGED TO FORM A UNIQUE SYMBOL, NAMELY, THE LETTER "G" WITH A PEACE SIGN RUNNING THROUGH IT.

CLASS 14—JEWELRY

FOR JEWELRY AND COSTUME JEWELRY (U.S. CLS. 2, 27, 28 AND 50).

CLASS 25—CLOTHING

FOR APPAREL, NAMELY, TOPS, BOTTOMS, SHIRTS, PANTS, HOODIES, AND SHORTS (U.S. CLS. 22 AND 39).

MARK SHINER, EXAMINING ATTORNEY

SN 85-012,446. FLIGHT FOCUS PTE. LTD., SINGAPORE, SINGAPORE, FILED 4-13-2010.



PRIORITY CLAIMED UNDER SEC. 44(D) ON SINGAPORE APPLICATION NO. T0911577H, FILED 10-13-2009, REG. NO. T0911577H, DATED 10-13-2009, EXPIRES 10-13-2019.

PRIORITY CLAIMED UNDER SEC. 44(D) ON SINGAPORE APPLICATION NO. T0911575A, FILED 10-13-2009, REG. NO. T0911575A, DATED 10-13-2009, EXPIRES 10-13-2019.

PRIORITY CLAIMED UNDER SEC. 44(D) ON SINGAPORE APPLICATION NO. T0911574C, FILED 10-13-2009, REG. NO. T0911574C, DATED 10-13-2009, EXPIRES 10-13-2019.

PRIORITY CLAIMED UNDER SEC. 44(D) ON SINGAPORE APPLICATION NO. T0911572G, FILED 10-13-2009, REG. NO. T0911572G, DATED 10-13-2009, EXPIRES 10-13-2019.

NO CLAIM IS MADE TO THE EXCLUSIVE RIGHT TO USE "FLIGHT", APART FROM THE MARK AS SHOWN.

THE COLOR(S) RED AND BLUE IS/ARE CLAIMED AS A FEATURE OF THE MARK.

THE MARK CONSISTS OF A RED TRIANGLE, A BLUE TRIANGLE, THE WORDS "FLIGHT FOCUS" IN BLUE WITH THE "I" STYLIZED IN COLORS BLUE AND RED.

CLASS 9—ELECTRICAL AND SCIENTIFIC APPARATUS

FOR COMPUTER KEYBOARDS; RECORDED COMPUTER OPERATING PROGRAMS; DOWNLOADABLE SOFTWARE FOR AIR-FLIGHT MANAGEMENT; COMPUTER PERIPHERAL DEVICES; COMPUTER PROGRAMS FOR FLIGHT MANAGEMENT; COMPUTERS; PRINTERS FOR USE WITH COMPUTERS; CONNECTIONS FOR ELECTRIC LINES, ELECTRIC CONNECTORS; ELECTRIC CONTROL PANELS; ELECTRIC CONVERTERS; ACOUSTIC COUPLERS, NAMELY, DATA PROCESSING EQUIPMENT; MAGNETIC AND OPTICAL DATA MEDIA FOR ELECTRONIC STORAGE, NAMELY, AIR FLIGHT RELATED DATA, NAMELY, METEOROLOGICAL, ROUTING, TRAFFIC AND NAVIGATION; ELECTRONIC DATA CARRIERS, NAMELY, USB-STICKS; DISK DRIVES FOR COMPUTERS; ELECTRIC INSTALLATIONS FOR AIRCRAFTS, NAMELY, WIRE BUNDLES AND CONNECTORS; MAGNETIC IDENTITY CARDS, RFID IDENTITY CARDS; INTER-COMMUNICATION APPARATUS, NAMELY, FIBER OPTIC CABLE; INTERFACES FOR COMPUTERS; LAPTOP COMPUTERS; MAGNETIC DATA MEDIA FEATURING AIR FLIGHT RELATED DATA, NAMELY, METEOROLOGICAL, ROUTING, TRAFFIC AND NAVIGATION; MAGNETIC ENCODERS; MAGNETIC TAPE UNITS FOR COMPUTERS; COMPUTER MONITORS; COMPUTER MOUSE; NAVIGATION APPARATUS FOR AIRCRAFTS, NAMELY, ON-BOARD COMPUTERS; NOTEBOOK COMPUTERS; ELECTRONIC NOTICE BOARDS; OPTICAL CHARACTER READERS; BLANK OPTICAL DATA CARRIERS; BLANK OPTICAL DISCS; RADIOS, TRANSCEIVERS, RADIO RELAYS, AND RADIO REPEATERS FOR COMPUTER COMMUNICATION PURPOSES; AIRCRAFT RADIOS AND TRANSCEIVERS; SATELLITE NAVIGATIONAL AND COMMUNICATION APPARATUS; SCANNERS, NAMELY, DATA PROCESSING EQUIPMENT; BLANK SMART CARDS AND BLANK INTEGRATED CIRCUIT CARDS (U.S. CLS. 21, 23, 26, 36 AND 38).

CLASS 35—ADVERTISING AND BUSINESS

FOR BUSINESS ORGANIZATION CONSULTANCY FOR THE COMMERCIAL FLIGHT TRANSPORTATION INDUSTRY; COMMERCIAL MANAGEMENT ASSISTANCE FOR THE COMMERCIAL FLIGHT TRANSPORTATION INDUSTRY; COMPILATION OF FLIGHT DATA INFORMATION INTO COMPUTER DATABASES; COMPILATION OF FLIGHT STATISTICS; PROFESSIONAL BUSINESS CONSULTANCY FOR THE COMMERCIAL FLIGHT TRANSPORTATION INDUSTRY; COST PRICE ANALYSIS; ECONOMIC FORECASTING FOR THE COMMERCIAL FLIGHT TRANSPORTATION INDUSTRY; BUSINESS EFFICIENCY ANALYSIS FOR THE COMMERCIAL FLIGHT TRANSPORTATION INDUSTRY; COMPUTERIZED FILE MANAGEMENT; PERSONNEL MANAGEMENT CONSULTANCY FOR THE COMMERCIAL FLIGHT TRANSPORTATION INDUSTRY; NEWS CLIPPING SERVICES; PRICE COMPARISON SERVICES FOR THE COMMERCIAL FLIGHT TRANSPORTATION INDUSTRY; PROCUREMENT SERVICES FOR OTHERS IN THE AREA OF COMMERCIAL FLIGHT TRANSPORTATION INDUSTRY, PURCHASING GOODS AND SERVICES FOR OTHER BUSINESSES IN THE AREA OF COMMERCIAL FLIGHT TRANSPORTATION INDUSTRY; ADMINISTRATIVE PROCESSING OF PURCHASE ORDERS IN THE AREA OF COMMERCIAL FLIGHT TRANSPORTATION INDUSTRY, NAMELY, FOR AIRCRAFT FUEL; DRAWING UP OF STATEMENTS OF ACCOUNTS; COMPILATION OF STATISTICS FOR THE COMMERCIAL FLIGHT TRANSPORTATION INDUSTRY; ARRANGING SUBSCRIPTIONS TO TELECOMMUNICATION SERVICES FOR OTHERS IN THE AREA OF COMMERCIAL FLIGHT TRANSPORTATION INDUSTRY; PROVIDING FUEL MANAGEMENT SERVICES IN THE FIELD OF AVIATION; TRACKING, LOCATING AND MONITORING AIRCRAFT FOR COMMERCIAL PURPOSES (U.S. CLS. 100, 101 AND 102).

CLASS 38—COMMUNICATION

FOR COMPUTER AIDED TRANSMISSION OF MESSAGES AND IMAGES; COMMUNICATIONS BY COMPUTER TERMINALS; ELECTRONIC BULLETIN BOARD SERVICES, NAMELY, TELECOMMUNICATIONS SERVICES FOR AIRCRAFTS; ELECTRONIC MAIL; PROVIDING ACCESS TO DATABASES; PROVIDING TELECOMMUNICATION CHANNELS FOR AIRCRAFT SERVICES; PROVIDING TELECOMMUNICATIONS CONNECTIONS TO A GLOBAL COMPUTER NETWORK; PROVIDING USER ACCESS TO A GLOBAL COMPUTER NETWORK SERVICE PROVIDERS; RENTAL OF ACCESS TIME TO GLOBAL COMPUTER NETWORKS; SATELLITE TRANSMISSION; PROVIDING TELECOMMUNICATION CHANNELS AIRCRAFT DISPATCHING AND NAVIGATION; TELECOMMUNICATIONS ROUTING AND JUNCTION SERVICES; COMPUTER AIDED TRANSMISSION OF MESSAGES AND IMAGES (U.S. CLS. 100, 101 AND 104).

CLASS 39—TRANSPORTATION AND STORAGE

FOR RENTAL OF ON-BOARD COMPUTER APPARATUS FOR AIRCRAFT, NAMELY, PROVIDING MAPING, FLIGHT AND ROUTING NAVIGATIONAL AID; AIR NAVIGATION PLANNING SERVICES FOR PILOTS (U.S. CLS. 100 AND 105).

CLASS 41—EDUCATION AND ENTERTAINMENT

FOR PUBLICATION OF BOOKS ON AIRCRAFT NAVIGATION AND OPERATIONAL DATA; PUBLISHING OF BOOK AIR FLIGHT PLANS, AIR NAVIGATION PLANS, FUEL CONSUMPTION ANALYSIS AND AIR FLIGHT TRACKING; DIGITAL IMAGING SERVICES; PROFESSIONAL TRAINING IN THE AREA OF NAVIGATING AND OPERATING AIRCRAFTS; PUBLICATION OF ELECTRONIC BOOKS AND JOURNALS ONLINE; ARRANGING AND CONDUCTING OF PROFESSIONAL TRAINING SEMINARS; PUBLICATION OF TEXTS AND TEXT BOOKS (U.S. CLS. 100, 101 AND 107).
EDWARD NELSON, EXAMINING ATTORNEY

SN 85-012,897. SIDE TRAIL CORPORATION N.V., CURA-CAO, NETHERLANDS ANTILLES, FILED 4-13-2010.

34 HERITAGE JEANS

THE MARK CONSISTS OF STANDARD CHARACTERS WITHOUT CLAIM TO ANY PARTICULAR FONT, STYLE, SIZE, OR COLOR.

NO CLAIM IS MADE TO THE EXCLUSIVE RIGHT TO USE "JEANS" IN CLASSES 25 AND 35, APART FROM THE MARK AS SHOWN.

CLASS 18—LEATHER GOODS

FOR GOODS MADE OF LEATHER, IMITATION LEATHER OR SYNTHETIC MATERIALS, NAMELY, TRAVEL BAGS, VALISES, WALLETS, LEATHER AND STOUT LEATHER BOXES FOR STORING GREETING CARDS, MAKE-UP CASES SOLD EMPTY, BOOK BAGS, CARRYING CASES FOR DOCUMENTS, BRIEFCASES, BACKPACKS, SCHOOL BAGS; UMBRELLAS, AND SUNSHADE PARASOLS (U.S. CLS. 1, 2, 3, 22 AND 41).

CLASS 25—CLOTHING

FOR CLOTHING, NAMELY, TROUSERS, JACKETS, OVERCOATS, COATS, SKIRTS, SUITS, JERSEYS, WAISTCOATS, SHIRTS, T-SHIRTS, SWEATSHIRTS, DRESSES, BERMUDA SHORTS, SHORTS, PAJAMAS, PULLOVERS, JEANS, TRACKSUITS, RAINWEAR, BEACHWEAR, BATHING SUITS, AND SWIMMING SUITS; SPORTSWEAR, NAMELY, SHORTS, SHIRTS; INFANT WEAR; UNDERCLOTHING, NAMELY, BOXER SHORTS, BRASSIERES, BRIEFS, PANTS, AND SOCKS; FOOTWEAR, NAMELY, SHOES EXCLUDING ORTHOPEDIC SHOES, SANDALS, WATERPROOF BOOTS, WALKING BOOTS, BOOTIES, SPORTING SHOES, AND SLIPPERS; HEADGEAR, NAMELY, CAPS, SKULL CAPS, SPORTS CAPS, HATS, AND BERETS; GLOVES AS CLOTHING, STOCKINGS, BELTS, LEATHER BELTS, CAMISOLES, SARONGS, SCARVES, NECK SCARVES, SHAWLS, COLLARS, NECKTIES, TIES, AND SUSPENDER BELTS (U.S. CLS. 22 AND 39).

CLASS 35—ADVERTISING AND BUSINESS

FOR WHOLESALE AND RETAIL STORE SERVICES AND ON-LINE RETAIL AND WHOLESALE STORE SERVICES FEATURING GOODS MADE OF LEATHER AND IMITATION LEATHER, CLOTHING, AND CLOTHING ACCESSORIES (U.S. CLS. 100, 101 AND 102).

JASON BLAIR, EXAMINING ATTORNEY

SN 85-013,168. OPGI MANAGEMENT GP INC./GESTION OPGI GP INC., AS GENERAL PARTNER FOR OPGI MANAGEMENT LIMITED PARTNERSHIP, TORONTO, ONTARIO, CANADA, FILED 4-13-2010.



PRIORITY CLAIMED UNDER SEC. 44(D) ON CANADA APPLICATION NO. 1467671, FILED 1-29-2010, REG. NO. TMA783817, DATED 12-1-2010, EXPIRES 12-1-2025.

THE MARK CONSISTS OF THE WORDING "INTELLIGENCE DURABLE" OVER WHICH FOUR VERTICAL LINES OF VARYING SIZES ARE SHOWN NEXT TO A CURVED LINE.

CLASS 9—ELECTRICAL AND SCIENTIFIC APPARATUS

FOR DOWNLOADABLE ELECTRONIC PUBLICATIONS, NAMELY, NEWSLETTERS AND MAGAZINES IN THE FIELD OF ENVIRONMENTAL AWARENESS AND CORPORATE SUSTAINABILITY PROGRAMS (U.S. CLS. 21, 23, 26, 36 AND 38).

CLASS 16—PAPER GOODS AND PRINTED MATTER

FOR PRINTED PUBLICATIONS, NAMELY, NEWSLETTERS AND MAGAZINES IN THE FIELD OF ENVIRONMENTAL AWARENESS AND CORPORATE SUSTAINABILITY PROGRAMS (U.S. CLS. 2, 5, 22, 23, 29, 37, 38 AND 50).

CLASS 35—ADVERTISING AND BUSINESS

FOR PROMOTING AWARENESS OF ENVIRONMENTAL ISSUES, CONSERVATION, SUSTAINABILITY, BEST ENVIRONMENTAL PRACTICES, AND EMERGING ENVIRONMENTAL TECHNOLOGIES TO EXISTING CLIENTS (U.S. CLS. 100, 101 AND 102).

JENNIFER MARTIN, EXAMINING ATTORNEY

SN 85-014,542. VIFOR SA, VILLARS-SUR-GLANE, SWITZERLAND, FILED 4-15-2010.

MOMOMEGA

THE MARK CONSISTS OF STANDARD CHARACTERS WITHOUT CLAIM TO ANY PARTICULAR FONT, STYLE, SIZE, OR COLOR.

CLASS 5—PHARMACEUTICALS

FOR NUTRITIONAL SUPPLEMENTS; NUTRITIONAL SUPPLEMENTS IN CAPSULE FORM CONTAINING FATTY ACIDS; NATURALLY-SOURCED NUTRITIONAL SUPPLEMENTS CONTAINING OMEGA-3 AND OMEGA-6 FATTY ACIDS; NUTRITIONAL SUPPLEMENTS CONTAINING FISH OILS; FLAVORED NUTRITIONAL SUPPLEMENTS FOR ADULTS AND CHILDREN; NUTRITIONAL SUPPLEMENTS CONTAINING FATTY ACIDS, VITAMINS AND MINERALS; NUTRITIONAL SUPPLEMENTS IN THE FORM OF SWEETENED, FLAVORED EMULSIONS, DRINKS AND CHEWABLE TABLETS; EDIBLE FISH OILS FOR MEDICAL PURPOSES; ALL OF THE FOREGOING CONTAINING OMEGA FATTY ACIDS (U.S. CLS. 6, 18, 44, 46, 51 AND 52).

CLASS 29—MEATS AND PROCESSED FOODS

FOR EDIBLE OILS AND FATS; EDIBLE FISH OILS NOT FOR MEDICAL PURPOSES; MEAT, PROCESSED VEGETABLES, AND DAIRY PRODUCTS, EXCLUDING ICE CREAM, ICE MILK, AND FROZEN YOGURT, SUPPLEMENTED WITH ESSENTIAL FATTY ACIDS (U.S. CL. 46).

CLASS 30—STAPLE FOODS

FOR BREADS, MUFFINS, ROLLS, PASTRIES, PASTAS, BAKERY GOODS, GRAIN-BASED SNACK FOODS AND BEVERAGES SUPPLEMENTED WITH ESSENTIAL FATTY ACIDS (U.S. CL. 46).

CLASS 32—LIGHT BEVERAGES

FOR FRUIT DRINKS AND FRUIT-BASED BEVERAGES SUPPLEMENTED WITH ESSENTIAL FATTY ACIDS (U.S. CLS. 45, 46 AND 48).

KARANENDRA S. CHHINA, EXAMINING ATTORNEY

SN 85-016,162. WHAM-O, INC., EMERYVILLE, CA. FILED 4-16-2010.

MOREY

THE MARK CONSISTS OF STANDARD CHARACTERS WITHOUT CLAIM TO ANY PARTICULAR FONT, STYLE, SIZE, OR COLOR.

OWNER OF U.S. REG. NOS. 1,278,158, 3,164,936 AND OTHERS.

CLASS 6—METAL GOODS

FOR METAL KEY CHAINS; METAL KEY RINGS (U.S. CLS. 2, 12, 13, 14, 23, 25 AND 50).

CLASS 9—ELECTRICAL AND SCIENTIFIC APPARATUS

FOR COMPUTER GAME SOFTWARE; EYEGLASS CASES; TELEPHONES; FASHION EYEGLASSES; SWIMMING GOGGLES; SNOW GOGGLES; DIVING GOGGLES; GOGGLES FOR SPORTS (U.S. CLS. 21, 23, 26, 36 AND 38).

CLASS 14—JEWELRY

FOR JEWELRY; COSTUME JEWELRY; EARRINGS; RINGS; MEDALLIONS; NON-MONETARY COINS OF PRECIOUS METAL; CLOCKS, WATCHES (U.S. CLS. 2, 27, 28 AND 50).

CLASS 21—HOUSEWARES AND GLASS

FOR DRINKING CUPS AND GLASSES (U.S. CLS. 2, 13, 23, 29, 30, 33, 40 AND 50).

CLASS 24—FABRICS

FOR TOWELS; BEACH TOWELS (U.S. CLS. 42 AND 50).

CLASS 25—CLOTHING

FOR BEACH SANDALS; PAJAMAS AND LOUNGEWEAR; SHORTS AND TOP SETS; PLAYSUITS; COVERALLS; COLLARLESS SHIRTS; SHORTS; SPORTS UNIFORMS; SWEATERS; JERSEYS; HEADWEAR; SCARVES; HEADBANDS; SHOES; NYLON SHELLS, NAMELY, NYLON JACKETS; HATS; CAPS; VISORS; SKI BIBS; WIND-RESISTANT JACKETS; T-SHIRTS; SWEATSHIRTS; SWEATPANTS; BASEBALL CAPS; COATS; PULLOVERS; SKI SUITS; GOLF SHIRTS AND HATS; LEGWARMERS; JEANS; LEOTARDS; WORKOUT AND SPORTS APPAREL, NAMELY, TANK TOPS, SPORTS BRAS; SKI MASKS (U.S. CLS. 22 AND 39).

CLASS 28—TOYS AND SPORTING GOODS

FOR BODY BOARDS; BAGS ESPECIALLY DESIGNED FOR SURFBOARDS; LEASHES USED IN CONJUNCTION WITH SURFING; SKIM BOARDS; SURF BOARDS; SWIM FINS; INFLATABLE FLOAT MATTRESSES OR PADS FOR RECREATIONAL USE; INFLATABLE INNER TUBES FOR AQUATIC RECREATIONAL USE; WATER SQUIRTING TOYS; SAND TOYS (U.S. CLS. 22, 23, 38 AND 50).

THEODORE MCBRIDE, EXAMINING ATTORNEY

SN 85-020,706. C.R. LAURENCE CO., INC., LOS ANGELES, CA. FILED 4-22-2010.

BLUMCRAFT

THE MARK CONSISTS OF STANDARD CHARACTERS WITHOUT CLAIM TO ANY PARTICULAR FONT, STYLE, SIZE, OR COLOR.

CLASS 6—METAL GOODS

FOR DOOR HARDWARE, NAMELY, METAL DOOR LOCKS, METAL DOOR HANDLES, METAL LATCHES, METAL BOLTS, METAL HINGES, METAL SIDE LIGHTS, METAL PANIC BARS, METAL DEADBOLTS, AND METAL GLAZING CHANNELS (U.S. CLS. 2, 12, 13, 14, 23, 25 AND 50).

FIRST USE 6-18-1956; IN COMMERCE 6-18-1956.

CLASS 19—NON-METALLIC BUILDING MATERIALS

FOR TEMPERED GLASS DOORS, GATES AND RAILINGS FOR ARCHITECTURAL BUILDINGS, AND COMPONENTS THEREFOR (U.S. CLS. 1, 12, 33 AND 50).

FIRST USE 12-31-1970; IN COMMERCE 12-31-1970.
LINDA E. BLOHM, EXAMINING ATTORNEY

SN 85-025,943. INTERTEK GROUP PLC, LONDON, UNITED KINGDOM, FILED 4-29-2010.



THE MARK CONSISTS OF THE LETTERS "ISI" BELOW THREE HORIZONTAL LINES OF DIFFERENT LENGTHS, ALL ENCLOSED IN A CIRCLE WITH THE BOTTOM LINE ENDING WITH A STAR.

CLASS 35—ADVERTISING AND BUSINESS

FOR COMPILING INFORMATION AND DATA RELATING TO PRODUCT ORIGIN, PRODUCT MANUFACTURER AND PRODUCT SAFETY; BUSINESS CONSULTATION, NAMELY, ANALYZING AND EVALUATING INFORMATION AND DATA RELATING TO PRODUCT ORIGIN AND PRODUCT MANUFACTURER; BUSINESS SERVICES, NAMELY, PROVIDING BENCHMARKING INFORMATION AND COMPARISON INFORMATION RELATING TO PRODUCT ORIGIN AND PRODUCT MANUFACTURER; BUSINESS CONSULTING SERVICES RELATING TO ASSESSMENT OF PRODUCT ORIGIN AND PRODUCT MANUFACTURER DATA; PREPARING AND GENERATING BUSINESS REPORTS RELATING TO PRODUCT ORIGIN AND PRODUCT MANUFACTURER; PROVIDING A DATABASE FOR TRACKING, MONITORING AND VIEWING BUSINESS REPORTS RELATING TO PRODUCT ORIGIN AND PRODUCT MANUFACTURER; ADVISORY AND CONSULTANCY SERVICES RELATING TO THE AFORESAID SERVICES; PROVISION OF CONSUMER INFORMATION, NAMELY, PRODUCT ORIGIN AND PRODUCT MANUFACTURER INFORMATION; BUSINESS ASSESSMENTS AND EVALUATIONS OF PRODUCT ORIGIN AND PRODUCT MANUFACTURER INFORMATION; ON-LINE COLLECTION, EVALUATION AND ASSESSMENT OF INFORMATION RELATING TO PRODUCT ORIGIN AND PRODUCT MANUFACTURER FOR THE PURPOSE OF MAKING INFORMED PURCHASING DECISIONS (U.S. CLS. 100, 101 AND 102).

CLASS 42—SCIENTIFIC AND COMPUTER SERVICES

FOR CONSULTING SERVICES RELATING TO ASSESSMENT OF PRODUCT SAFETY; ASSESSMENTS AND EVALUATIONS RELATING TO PRODUCT SAFETY; DEVELOPING VOLUNTARY STANDARDS FOR ASSESSING COMPLIANCE WITH PRODUCT SAFETY LAWS AND REGULATIONS; ADVISORY AND CONSULTANCY SERVICES RELATING TO ALL THE AFORESAID SERVICES (U.S. CLS. 100 AND 101).

CLASS 45—PERSONAL AND LEGAL SERVICES

FOR ASSESSMENT AND EVALUATION OF PRODUCT ORIGIN, PRODUCT MANUFACTURER, AND PRODUCT SAFETY INFORMATION TO DETERMINE COMPLIANCE WITH PRODUCT SAFETY LAWS AND REGULATIONS; PROVISION OF INFORMATION RELATING TO CONSUMER PRODUCT SAFETY; ANALYZING AND EVALUATING INFORMATION AND DATA RELATING TO PRODUCT SAFETY; PROVIDING BENCHMARKING INFORMATION AND COMPARISON INFORMATION RELATING TO PRODUCT SAFETY; ASSESSMENT OF PRODUCT SAFETY DATA; PREPARING AND GENERATING REPORTS RELATING TO PRODUCT SAFETY; PROVIDING A DATABASE FOR TRACKING, MONITORING AND VIEWING REPORTS RELATING TO PRODUCT SAFETY; CONSULTING SERVICES, NAMELY, ON-LINE COLLECTION, EVALUATION AND ASSESSMENT OF INFORMATION RELATING TO PRODUCT SAFETY; ON-LINE COLLECTION, EVALUATION AND ASSESSMENT OF INFORMATION RELATING TO PRODUCT ORIGIN AND PRODUCT MANUFACTURER FOR THE PURPOSE OF REGULATORY COMPLIANCE (U.S. CLS. 100 AND 101).

CAROLINE WOOD, EXAMINING ATTORNEY

SN 85-026,794. DATALOGIC MOBILE, INC., EUGENE, OR. FILED 4-29-2010.



OWNER OF U.S. REG. NO. 2,388,963.
THE MARK CONSISTS OF A DESIGN OF A FALCON IN PROFILE, WHICH INCLUDES THE WORD "FALCON", WHERE THE LETTERS "C" AND "O" ARE INCORPORATED INTO THE DESIGN OF THE EYE OF THE FALCON.

CLASS 9—ELECTRICAL AND SCIENTIFIC APPARATUS

FOR MICROPROCESSOR CONTROLLED PORTABLE HAND-HELD DATA TERMINAL AND SCANNING DEVICES FOR THE COLLECTION AND MANAGEMENT OF DATA, AND DOCKING STATIONS THEREFOR (U.S. CLS. 21, 23, 26, 36 AND 38).

CLASS 16—PAPER GOODS AND PRINTED MATTER

FOR INSTRUCTION, INSTALLATION AND MAINTENANCE MANUALS FOR DATA CAPTURE SYSTEMS, NAMELY, OPTICAL CODE READERS, BAR CODE SCANNERS, ELECTRONIC TAGS READERS AND WRITERS AND PORTABLE DATA TERMINALS; DOCUMENTATION AND PRINTED MATTER IN THE NATURE OF DATA SHEETS, REFERENCE GUIDES, AND USER MANUALS FOR CUSTOMER INFORMATION ON DATA CAPTURE SYSTEMS, NAMELY, OPTICAL CODE READERS, BAR CODE SCANNERS, ELECTRONIC TAGS READERS AND WRITERS AND PORTABLE DATA TERMINALS (U.S. CLS. 2, 5, 22, 23, 29, 37, 38 AND 50).

CLASS 37—CONSTRUCTION AND REPAIR

FOR INSTALLATION, REPAIR AND MAINTENANCE SERVICES FOR DATA CAPTURE SYSTEMS, NAMELY, OPTICAL CODE READERS, BAR CODE SCANNERS, ELECTRONIC TAGS READERS AND WRITERS AND PORTABLE DATA TERMINALS (U.S. CLS. 100, 103 AND 106).

YAT SYE, LEE, EXAMINING ATTORNEY

SN 85-031,154. SMARTHEALTH, INC., PHOENIX, AZ. FILED 5-5-2010.

SMARTPRACTICE

THE MARK CONSISTS OF STANDARD CHARACTERS WITHOUT CLAIM TO ANY PARTICULAR FONT, STYLE, SIZE, OR COLOR.

OWNER OF U.S. REG. NOS. 1,531,419, 2,454,568 AND OTHERS.

CLASS 5—PHARMACEUTICALS

FOR DENTAL AND MEDICAL PRODUCTS, NAMELY, ADHESIVES FOR DENTAL, MEDICAL AND VETERINARY USE; MEDICATED MOUTHWASHES, MOUTHWASHES FOR MEDICAL PURPOSES, DENTAL IMPRESSION MATERIALS, MATERIALS FOR STOPPING TEETH, DENTAL AMALGAMS, DENTAL AMALGAMS OF GOLD, PHARMACEUTICAL PREPARATIONS TO FACILITATE TEETHING, DENTAL MASTICS, DENTAL VARNISH AND SEALANTS FOR USE BY DENTISTS, ADHESIVE FOR DENTAL PROSTHESES, PORCELAIN FOR DENTAL PROSTHESES, ALLOYS OF PRECIOUS METALS FOR DENTAL PURPOSES; RUBBER FOR DENTAL PURPOSES, NAMELY, FOR USE AS DENTAL IMPRESSION MATERIALS; MOULDING WAX FOR DENTAL USE, DENTAL ABRASIVES; MEDICAL PRODUCTS, NAMELY, DIAGNOSTIC TEST PATCH WHICH IS APPLIED TO THE EXTERIOR SKIN IN ORDER TO DETECT ALLERGIC CONTACT DERMATITIS FOR USE IN DOCTORS OFFICES, HOSPITALS AND CLINICS; DISPOSABLE TOWELETTS IMPREGNATED WITH DISINFECTING CHEMICALS OR COMPOUNDS THEREFOR FOR USE IN HOSPITALS, DENTAL CLINICS, MEDICAL CLINICS AND MEDICAL OFFICES; VETERINARY SUPPLIES AND INSTRUMENTS, NAMELY, FLEA AND TICK PREVENTION POWDERS AND LIQUIDS (U.S. CLS. 6, 18, 44, 46, 51 AND 52).

CLASS 10—MEDICAL APPARATUS

FOR DENTAL PRODUCTS, NAMELY, CROWNS, DAMS, DRILLS, BITE TRAYS; MEDICAL PRODUCTS, NAMELY, DISPOSABLE MEDICAL GLOVES; MEDICAL SCRUBS, NAMELY, BOTTOMS, TOPS, UNDERSHIRTS AND CAPS; VETERINARY SUPPLIES AND INSTRUMENTS, NAMELY, DISPOSABLE MEDICAL GLOVES; MEDICAL WEARING APPAREL FOR VETERINARIANS, NAMELY, ROBES, SCRUBS AND FACE MASKS (U.S. CLS. 26, 39 AND 44).

CLASS 18—LEATHER GOODS

FOR VETERINARY SUPPLIES AND INSTRUMENTS, NAMELY, ANIMAL LEASHES, PAW COVERS, AND ANIMAL COLLARS (U.S. CLS. 1, 2, 3, 22 AND 41).

CLASS 21—HOUSEWARES AND GLASS

FOR VETERINARY PET GROOMING SUPPLIES AND INSTRUMENTS, NAMELY, COMBS, BRUSHES, TOOTHBRUSHES (U.S. CLS. 2, 13, 23, 29, 30, 33, 40 AND 50).

ALYSSA STEEL, EXAMINING ATTORNEY

SN 85-038,402. MS ENTERPRISES LIMITED, NT, HONG KONG, FILED 5-14-2010.

NELSON SNYDER, EXAMINING ATTORNEY

Bio Chef

THE MARK CONSISTS OF STANDARD CHARACTERS WITHOUT CLAIM TO ANY PARTICULAR FONT, STYLE, SIZE, OR COLOR.

PRIORITY CLAIMED UNDER SEC. 44(D) ON HONG KONG APPLICATION NO. 301600613, FILED 4-29-2010, REG. NO. 301600613, DATED 4-29-2010, EXPIRES 4-29-2020.

NO CLAIM IS MADE TO THE EXCLUSIVE RIGHT TO USE "CHEF", APART FROM THE MARK AS SHOWN.

CLASS 8—HAND TOOLS

FOR UTENSILS FOR HOUSEHOLD PURPOSES, NAMELY, NON-ELECTRIC FRUIT AND VEGETABLE PEELERS (SECTION 1(B) ONLY) (U.S. CLS. 23, 28 AND 44).

CLASS 9—ELECTRICAL AND SCIENTIFIC APPARATUS

FOR UTENSILS FOR HOUSEHOLD PURPOSES, NAMELY, MEASURING SPOONS (SECTION 1(B) ONLY) (U.S. CLS. 21, 23, 26, 36 AND 38).

CLASS 21—HOUSEWARES AND GLASS

FOR BASINS FOR USE AS BOWLS; BASINS FOR USE AS RECEPTACLES; BASTING SPOONS, FOR KITCHEN USE; DUST BINS; BOTTLE GOURDS; BOTTLE OPENERS; BOTTLES, SOLD EMPTY; BOWLS IN THE NATURE OF BASINS; BUCKETS; BUTTER DISHES; CAKE MOLDS; CHEESE-DISH COVERS; CHOPSTICKS; COASTERS, NOT OF PAPER AND OTHER THAN TABLE LINEN; CONTAINERS FOR HOUSEHOLD OR KITCHEN USE; COOKERY MOLDS; NON-ELECTRIC COOKING UTENSILS, NAMELY, GRILL COVERS AND WIRE BASKETS; CORKSCREWS; CUPS; EGG CUPS; CUPS FOR USE IN SERVING FRUIT; CUTTING BOARDS FOR THE KITCHEN; DISHES; BUTTER DISHES; DISHES FOR SOAP; DISHWASHING BRUSHES; DISPOSABLE TABLE PLATES; NON-ELECTRIC HAND-OPERATED FOOD GRINDERS FOR DOMESTIC USE; DRINKING GLASSES; DRINKING TROUGHS; DRINKING VESSELS; DRYING RACKS FOR WASHING, NAMELY, CLOTHES DRYING RACKS AND DISH DRYING RACKS; DUSTBINS; EGG CUPS; FEEDING TROUGHS; FEEDING TROUGHS FOR ANIMALS; FUNNELS; GARBAGE CANS; KITCHEN UTENSILS IN THE NATURE OF GARLIC PRESSES; HOUSEHOLD UTENSILS, NAMELY, GRATERS; TOILET PAPER HOLDERS; ICE BUCKETS; ICE CUBE MOLDS; ICE PAILS; KITCHEN CONTAINERS; NON-ELECTRIC KITCHEN MIXERS IN THE NATURE OF MIXING SPOONS; KITCHEN UTENSILS, NAMELY, SPLATTER SCREENS; LUNCH BOXES; MANUAL MIXERS, NAMELY, COCKTAIL SHAKERS; ICE CUBE MOLDS; COOKERY MOLDS; OIL CRUETS; PAILS; PASTRY CUTTERS; PITCHERS; POT LIDS; FLOWER POTS; REFUSE BINS; SALAD BOWLS; SALT CELLARS; SALT SHAKERS; TABLEWARE IN THE NATURE OF SCOOPS; FLOUR SIFTERS; SOUP BOWLS; HOUSEHOLD KITCHEN UTENSILS, NAMELY, SPATULAS; BASTING SPOONS FOR KITCHEN USE; STRAINERS FOR HOUSEHOLD PURPOSES; SUGAR BOWLS; TABLEWARE, OTHER THAN KNIVES, FORKS AND SPOONS, NAMELY, SERVING FORKS, LADLES AND SPOONS; TART SCOOPS; THERMALLY INSULATED CONTAINERS FOR FOOD; TRASH CANS; TRAYS FOR DOMESTIC PURPOSES; UTENSILS FOR HOUSEHOLD PURPOSES, NAMELY, TURNER, SLOTTED SERVING SPOON, PASTA SERVING FORK, MIXING BOWL, STRAINER BOWL; DISHES FOR USE IN SERVING VEGETABLES; WHISKS, NON-ELECTRIC, FOR HOUSEHOLD PURPOSES (SECTION 44(E) ONLY) (U.S. CLS. 2, 13, 23, 29, 30, 33, 40 AND 50).

SN 85-038,499. VOLT INFORMATION SCIENCES, INC., ORANGE, CA. FILED 5-14-2010.

PARTNER WITH US. COMPETE WITH ANYBODY

THE MARK CONSISTS OF STANDARD CHARACTERS WITHOUT CLAIM TO ANY PARTICULAR FONT, STYLE, SIZE, OR COLOR.

CLASS 35—ADVERTISING AND BUSINESS

FOR ASSISTANCE TO INDUSTRIAL OR COMMERCIAL ENTERPRISES IN THE RUNNING OF THEIR BUSINESS; ASSISTANCE, ADVISORY SERVICES AND CONSULTANCY WITH REGARD TO BUSINESS PLANNING, BUSINESS ANALYSIS, BUSINESS MANAGEMENT, AND BUSINESS ORGANIZATION; BUSINESS ASSISTANCE SERVICES IN BUSINESS ADMINISTRATION AND OFFICE WORK, NAMELY, PROCURING PERSONNEL TO COMPANIES TO ASSIST IN CLERICAL SERVICES, ARCHIVING, CLAIMS PROCESSING, COMPETITIVE PRICE SHOPPING, PROCESSING CUSTOMER RESPONSE, DATA ENTRY AND DATA PROCESSING; BUSINESS OFFICE WORK AND OFFICE FUNCTIONS, NAMELY, PREPARING E-MAIL RESPONSES, EXECUTIVE ASSISTANCE, FACT CHECKING, FORM FILING, MAILING LIST DEVELOPMENT, BUSINESS MEETING AND EVENT PLANNING, ONLINE ORDERING, ORDER ENTRY, ORDER PROCESSING AND WORD PROCESSING AND GENERAL AND ADMINISTRATIVE OFFICE WORK; BUSINESS ASSISTANCE SERVICES IN THE FIELD OF ON-LINE ORDERING SERVICE FEATURING VARIOUS GENERAL MERCHANDISE AND GENERAL CONSUMER GOODS, NAMELY, PROVIDING PERSONNEL TO COMPANIES TO PERFORM FUNCTIONS RELATING TO SALES AND MARKETING, NAMELY, PREPARING MAILING AND E-MAILING LISTS, E-MAIL CAMPAIGN MANAGEMENT, ONLINE MARKETING, TELEMARKETING AND TELESALLES; GENERAL BUSINESS ADMINISTRATION SERVICES, NAMELY, OPERATING THE ONLINE ORDERING BUSINESS OF OTHER, ORDER TAKING AND ORDER PROCESSING SERVICES; CUSTOMER SERVICE, NAMELY, PROCESSING TELEPHONE AND E-MAIL INQUIRIES REGARDING ADVERTISED GOODS; CUSTOMER SERVICE MANAGEMENT FOR OTHERS; BUSINESS CONSULTING SERVICES RELATING TO PRODUCT DISTRIBUTION, OPERATIONS MANAGEMENT SERVICES, LOGISTICS, REVERSE LOGISTICS, SUPPLY CHAIN, AND PRODUCTION SYSTEMS AND DISTRIBUTION SOLUTIONS; BUSINESS MANAGEMENT ASSISTANCE TO INDUSTRIAL OR COMMERCIAL COMPANIES; BUSINESS MANAGEMENT CONSULTATION IN THE FIELD OF EXECUTIVE AND LEADERSHIP DEVELOPMENT; BUSINESS MANAGEMENT CONSULTING AND ADVISORY SERVICES IN THE FIELD OF STAFFING AND BUSINESS PROCESS OUTSOURCING; PROVIDING BUSINESS OPERATION, BUSINESS ADMINISTRATION AND OFFICE FUNCTIONS; BUSINESS ORGANIZATION, OPERATION AND MANAGEMENT CONSULTANCY; BUSINESS PROCESS OUTSOURCING AND BUSINESS ASSISTANCE SERVICES IN THE FIELDS OF ACCOUNTING AND ACCOUNTANCY, NAMELY, PROVIDING PERSONNEL TO COMPANIES TO CONDUCT ACCOUNT/BUSINESS AUDITS, ACCOUNTS RECEIVABLES SERVICES, ACCOUNTS PAYABLES SERVICES, BANK RECONCILIATION, BOOKKEEPING SERVICES, BUDGETING AND FORECASTING, BUSINESS PAYROLL ADMINISTRATION, BUSINESS INVOICING, COMMISSIONS REPORTS, COST ANALYSIS AND REDUCTION, DUE DILIGENCE SUPPORT, FINANCIAL RECORDS MANAGEMENT, FINANCIAL STATEMENT PREPARATION AND ANALYSIS, RISK ANALYSIS, TAX PLANNING AND STRUCTURING AND PERFORM ALL OTHER FUNCTIONS RELATING TO ACCOUNTING

AND ACCOUNTANCY; BUSINESS PROCESS OUTSOURCING AND BUSINESS ASSISTANCE SERVICES IN THE FIELDS OF ADVERTISING, MARKETING, PROMOTION AND BUSINESS MANAGEMENT CONSULTANCY, NAMELY, PROVIDING PERSONNEL TO COMPANIES TO PROMOTE AND MARKET THE GOODS AND SERVICES OF OTHERS THROUGH ALL MEDIA AND PUBLIC COMMUNICATIONS MEANS AND PERFORM ALL FUNCTIONS RELATING TO ADVERTISING, MARKETING, PROMOTION AND BUSINESS MANAGEMENT; BUSINESS PROCESS OUTSOURCING AND BUSINESS ASSISTANCE SERVICES IN THE FIELDS OF BUSINESS DEVELOPMENT, NAMELY, PROVIDING PERSONNEL TO COMPANIES TO CONDUCT BUSINESS, MARKET AND CONSUMER RESEARCH SURVEYS AND PROVIDE BUSINESS DEVELOPMENT PLANS AND FEASIBILITY STUDIES AND PERFORM ALL FUNCTIONS RELATING TO BUSINESS DEVELOPMENT; BUSINESS PROCESS OUTSOURCING SERVICES IN THE FIELD OF STAFFING; BUSINESS PROCESS RE-ENGINEERING SERVICES; BUSINESS RECORDS MANAGEMENT FOR OTHERS; BUSINESS RESEARCH FOR OTHERS, NAMELY, PROVIDING ANALYSIS OF DATA ON VARIOUS BUSINESS MATTERS; BUSINESS SERVICES, NAMELY, PROCURING QUALIFIED PROFESSIONALS AND PERSONNEL, AND DOCUMENTATION AND INFORMATION ALL ON BEHALF OF OTHERS; BUSINESS SERVICES, NAMELY, REGISTERING, SCREENING, CREDENTIALING, AND ORGANIZING THIRD-PARTY VENDORS, SUPPLIERS, AND CONTRACTORS, AND DOCUMENTATION AND INFORMATION RELATED THERETO, ON BEHALF OF OTHERS; BUSINESS SERVICES, NAMELY, TRACKING, COMPARING AND MONITORING EMPLOYEE COST ITEMS FOR OTHERS; CANDIDATE SCHEDULING SERVICES, NAMELY, SETTING UP INTERVIEWING LOGISTICS FOR CLIENTS AND THEIR POTENTIAL HIRES, NAMELY, ARRANGING MEETING TIME, LOCATION AND RELATED DETAILS; CAREER PLACEMENT; CONDUCTING EMPLOYEE INCENTIVE AWARD PROGRAMS TO PROMOTE ON THE JOB SAFETY, QUALITY, PRODUCTIVITY AND ATTENDANCE; CONSULTANCY OF PERSONNEL RECRUITMENT; CONSULTING SERVICES IN THE AREA OF SUSTAINABLE BUSINESS SOLUTIONS; CONSULTING SERVICES IN THE FIELD OF HUMAN RESOURCES DEVELOPMENT FOR THE PROMOTION OF EMPLOYEE RETENTION, CAREER GROWTH, AND INCREASED PRODUCTIVITY FOR EMPLOYEES AND EMPLOYERS; CREATIVE MARKETING DESIGN SERVICES AND DESIGN OF ADVERTISING MATERIALS FOR OTHERS; DATA MANAGEMENT SERVICES FOR OTHERS, NAMELY, ELECTRONIC DATA COLLECTION AND ONLINE CLAIMS MANAGEMENT; DATA PROCESSING SERVICES AND DATABASE MANAGEMENT FOR OTHERS; ECONOMIC CONSULTING AND INFORMATION FOR THE INDUSTRIAL AND COMMERCIAL SECTORS FOR PLANNING, ORGANIZING, MONITORING AND CARRYING OUT UNIQUE AND COMPLEX PROJECTS IN DIFFERENT SECTORS OF ONE OR SEVERAL COMPANIES; ELECTRONIC COMMERCE SERVICES FOR OTHERS, NAMELY, PROVIDING INFORMATION ABOUT PRODUCTS AND SERVICES VIA TELECOMMUNICATION NETWORKS FOR ADVERTISING AND SALES PURPOSES AND ELECTRONIC PROCESSING OF ORDERS FOR OTHERS; EMPLOYEE LEASING; EMPLOYEE RELATIONS INFORMATION SERVICES; EMPLOYEE RELOCATION AND INFORMATION; EMPLOYMENT AGENCIES; EMPLOYMENT COUNSELING, HIRING, RECRUITING, PLACEMENT, STAFFING AND CAREER NETWORKING SERVICES; EMPLOYMENT OUTPLACEMENT AND OUTSOURCING SERVICES AND OTHER CONTINGENT STAFFING AND PERMANENT PLACEMENT SERVICES, NAMELY, EMPLOYMENT RECRUITING CONSULTATION, EMPLOYMENT VERIFICATION, EXECUTIVE SEARCH AND PLACEMENT SERVICES, HUMAN CAPITAL MANAGEMENT OUTSOURCING SERVICES; HUMAN RESOURCES ADMINISTRATION, MANAGEMENT AND CONSULTATION; HUMAN RESOURCES SERVICES, NAMELY, PERSONNEL SELECTION FOR OTHERS; INFORMATION, ADVISORY AND CONSULTANCY SERVICES RELATING TO BUSINESS AND MANAGEMENT OR BUSINESS ADMINISTRATION, NAMELY, PROVIDING SUCH SERVICES ONLINE OR VIA THE INTERNET; JOB AND PERSONNEL PLACEMENT; MANAGEMENT OF TELEPHONE CALL CENTERS FOR OTHERS; MANAGEMENT ON BEHALF OF INDUSTRIAL AND COMMERCIAL ENTERPRISES IN

TERMS OF SUPPLYING THEM WITH OFFICE REQUISITES; MANAGING TELECOMMUNICATIONS NETWORKS FOR OTHERS, NAMELY, MANAGING TELEPHONE SERVICE FOR OTHER CARRIERS; OFFER/HIRE SERVICES, NAMELY, DETERMINING SALARY BASED ON THE CLIENT'S INTERNAL PAY GRADE SCALES AND LOCATION, VERBALLY EXTENDING THE OFFER TO THE CANDIDATE, NEGOTIATING WITH THE HIRING MANAGER, AND MANAGING THE ENTIRE PROCESS THROUGH TO THE END OF SETTING THE START DATE FOR THE CANDIDATE; ON-LINE SERVICES FOR ORDERING AND INVENTORY MANAGEMENT FOR OTHERS IN THE FIELD OF GENERAL MERCHANDISE AND GENERAL CONSUMER GOODS; OPERATING ON-LINE MARKETPLACES FOR SELLERS OF GOODS AND/OR SERVICES FOR OTHERS IN THE FIELD OF GENERAL MERCHANDISE AND GENERAL CONSUMER GOODS; OPERATION OF A TELEPHONE SWITCHBOARD FOR OTHERS; OPERATION OF TELEPHONE CALL CENTERS FOR OTHERS; OPERATION OF TELEPHONE COMMUNICATION CENTERS FOR OTHERS; ORDER FULFILLMENT SERVICES FOR OTHERS; OUTSOURCING IN THE FIELD OF STAFFING; OUTSOURCING SERVICES, NAMELY, PROVIDING PROFESSIONAL AND CLERICAL SERVICES FOR OTHERS; BUSINESS CONSULTATION SERVICES IN THE FIELD OF TRACKING PERFORMANCE MANAGEMENT; PERSONNEL MANAGEMENT CONSULTATION; PERSONNEL PLACEMENT AND RECRUITMENT; PERSONNEL RELOCATION; PROJECT MANAGEMENT SERVICES FOR OTHERS IN THE FIELDS OF LANGUAGE TRANSLATION, CUSTOM WRITING, TEXT ADAPTATION, INTERPRETING AND PROOFREADING; PROVIDING ASSISTANCE, FITNESS EVALUATION AND CONSULTATION TO CORPORATE CLIENTS TO HELP THEIR EMPLOYEES MAKE HEALTH, WELLNESS AND NUTRITIONAL CHANGES IN THEIR DAILY LIVING TO INCREASE PRODUCTIVITY AND LOWER HEALTH CARE COSTS; PROVIDING BUSINESS INFORMATION, ALSO VIA INTERNET, THE CABLE NETWORK OR OTHER FORMS OF DATA TRANSFER; PROVIDING CAREER INFORMATION; PROVIDING CONSUMER INFORMATION IN THE FIELD OF STAFFING; PROVIDING INCENTIVE AWARD PROGRAMS FOR CUSTOMERS AND EMPLOYEES FOR THE PURPOSE OF PROMOTING AND REWARDING LOYALTY; PROVIDING OFFICE FUNCTIONS; PROVIDING OFFICE SUPPORT STAFF SERVICES; PSYCHOLOGICAL TESTING FOR THE SELECTION OF PERSONNEL; RESUME PREPARATION; SERVING AS A HUMAN RESOURCES DEPARTMENT FOR OTHERS; SOURCING, NAMELY, FINDING EMPLOYEE CANDIDATE TALENT BY USING A COMPANY'S INTERNAL AND/OR EXTERNAL DATABASE AND TOOLS; STAFFING REQUISITION PROCESSING AND MANAGEMENT, NAMELY, ESTABLISHING QUALIFICATION OF THE REQUISITION WITH THE CLIENT'S HIRING MANAGER, POSTING THE REQUISITION INTERNALLY AND EXTERNALLY, MANAGING THE REQUISITION THROUGH THE HIRING LIFECYCLE, DOWN SELECTING THE APPLICANT POOL, DISPOSITIONING THE APPLICANTS NOT SELECTED, NAMELY, ADVISING APPLICANTS OF THEIR STATUS; EMPLOYMENT COUNSELING SERVICES FEATURING ADVICE IN THE AREA OF INTERVIEW SKILLS; EMPLOYMENT AGENCY SERVICES WHEREBY QUALIFIED APPLICANTS ARE FORWARDED TO HIRING MANAGERS FOR REVIEW; TELEPHONE OPERATOR SERVICES FOR OTHERS; TELEPHONE ORDER-TAKING SERVICES FOR OTHERS; TEMPORARY EMPLOYMENT AGENCIES; TEMPORARY HELP AND EMPLOYMENT SERVICES, NAMELY, PROVIDING EMPLOYEES TO COMPANIES ON AN HOURLY, PER DIEM OR CONTRACT BASIS; TESTING TO DETERMINE EMPLOYMENT SKILLS, JOB AND PROFESSIONAL COMPETENCY; STAFFING SERVICES FOR OFFSHORE BUSINESSES; OUTSOURCING SERVICES, NAMELY, PROVIDING PROFESSIONAL AND CLERICAL SERVICES FOR OTHERS; STAFFING SERVICES; CONSULTING SERVICES IN THE FIELDS OF OUTSOURCING AND STAFFING; ACCOUNTING AND FINANCE SUPPORT SERVICES, NAMELY, BUSINESS AUDIT PREPARATION, BANK RECONCILIATION, BOOKKEEPING; ECONOMIC BUDGETING, FORECASTING, AND ANALYSIS; NEGOTIATION SERVICES, NAMELY, NEGOTIATION AND SETTLEMENT OF BUSINESS TRANSACTIONS FOR THIRD PARTIES; PREPARATION OF BUSINESS REPORTS, NAMELY,

COMMISSION REPORTS, COST ANALYSIS AND REDUCTION REPORTS; CREDIT CARD REGISTRATION; MONITORING CONSUMER CREDIT REPORTS; ACCOUNTING SERVICES IN THE FIELD OF EMPLOYEE EXPENSE REIMBURSEMENTS; FINANCIAL STATEMENT PREPARATION FOR BUSINESSES; FIXED ASSETS SERVICES, NAMELY, CONNECTING BUYERS AND SELLERS OF FIXED ASSETS; INVOICING SERVICES; BILLING; PAYROLL PROCESSING SERVICES; BUSINESS STRUCTURING, NAMELY, ADVISORY SERVICES AND CONSULTING WITH REGARD TO BUSINESS ORGANIZATION; VENDOR QUOTATIONS, NAMELY, OBTAINING AND DISSEMINATING PRICE QUOTATIONS ON GOODS/SERVICES; HUMAN RESOURCES MANAGEMENT AND ADMINISTRATION SERVICES; PRICE COMPARISON SERVICES, NAMELY, COMPETITIVE PRICE SHOPPING; CUSTOMER RESPONSE, NAMELY, RESPONDING TO CUSTOMER SERVICE INQUIRIES AND E-MAILED CUSTOMER SERVICE INQUIRIES FOR OTHERS; DATA PROCESSING SERVICES, NAMELY, DATA ENTRY, DATA PROCESSING; BUSINESS MEETING PLANNING; ONLINE ORDER PROCESSING SERVICES FOR OTHERS; MESSAGE TRANSCRIPTION SERVICES, NAMELY, TRANSCRIBING AUDIO FOR OTHERS; ORDER FULFILLMENT TRANSCRIPTION; APPOINTMENT SCHEDULING SERVICES; STRATEGIC PLANNING, NAMELY, PROVIDING BUSINESS MANAGEMENT INFORMATION IN CONNECTION WITH CONSULTING AND ADVISORY SERVICES IN THE FIELD OF STRATEGIC PLANNING; TELEPHONE OPERATOR/ATTENDANT SERVICES; WEB RESEARCH IN THE FIELDS OF MARKET RESEARCH AND CONSUMER RESEARCH; WORD PROCESSING; SALES PROMOTION AND BUSINESS MARKETING SERVICES; ADVERTISING SERVICES, NAMELY, CREATING BRAND IDENTITIES FOR OTHERS; BUSINESS DEVELOPMENT SERVICES, NAMELY, PROVIDING START-UP SUPPORT FOR BUSINESSES OF OTHERS; BUSINESS PLANNING; OPERATION OF CALL CENTER OPERATIONS FOR OTHERS; ACCOUNTING SERVICES, NAMELY, CALCULATION OF SALES COMMISSIONS AND ANALYSIS OF COMMISSION REPORTS; BUSINESS CONSULTANCY AND ANALYSIS SERVICES, NAMELY, ANALYSIS OF BUSINESS COMPETITORS; BUSINESS MANAGEMENT CONSULTANCY SERVICES; CONTENT WRITING, NAMELY, WRITING OF PUBLICITY TEXTS; CUSTOMER RELATIONSHIP MANAGEMENT; CONDUCTING CUSTOMER SURVEYS; DIRECT MARKETING SERVICES; BUSINESS RESEARCH USING FOCUS GROUPS; LEAD GENERATION, NAMELY, GENERATING BUSINESS LEADS FOR OTHERS; MAILING LIST PREPARATION; MARKET RESEARCH; MARKETING COMMUNICATION, NAMELY, PROMOTING AND MARKETING THE GOODS AND SERVICES OF OTHERS USING ALL PUBLIC COMMUNICATION MEANS; MARKETING PLAN DEVELOPMENT; ONLINE MARKETING SERVICES; PAY FOR RANKING, NAMELY, PROCURING INTERNET RANKINGS FOR OTHERS; PRODUCT MANAGEMENT, NAMELY, BUSINESS CONSULTING REGARDING MARKETING AND LAUNCHING OF NEW PRODUCTS; PUBLIC RELATIONS; ORGANIZATION AND CONDUCTION OF PRODUCT SALES PRESENTATIONS; TELEMARKETING; TELESALLES, NAMELY, PROVIDING ORDER TAKING FOR OTHERS; ARRANGING AND CONDUCTING TRADESHOWS FOR OTHERS IN THEIR RESPECTIVE SERVICE AREAS; WRITING BUSINESS PLAN AND PROPOSALS FOR OTHERS; PROVIDING ON-LINE CUSTOMER SERVICE, NAMELY, PROVIDING TECHNICAL SUPPORT IN THE NATURE OF MANAGING CALL CENTERS FOR OTHERS; PREPARING SPEECHES AND ORAL PRESENTATIONS FOR OTHERS FOR USE IN ADVERTISING; PROMOTION OF THE DEVELOPMENT, SYNTHESIS AND ADOPTION OF E-BUSINESS AND INFORMATION EXCHANGE STANDARDS FOR THE E-COMMERCE BUSINESSES THROUGH THE DISSEMINATION OF ADVERTISEMENTS, PRESS RELEASES, WHITE PAPERS, TRADE JOURNALS, MULTIMEDIA PRESENTATIONS AND WEB CONTENT ON GLOBAL COMPUTER NETWORKS; WEB MARKETING, NAMELY, PROVIDING MARKETING ON ON-LINE WEBSITES FOR OTHERS; BUSINESS RESEARCH; E-MAIL CAMPAIGN MANAGEMENT, NAMELY, MANAGING E-MAIL CAMPAIGNS FOR OTHERS; CUSTOMER SERVICE MANAGEMENT FOR OTHERS, NAMELY, MANAGING E-MAIL SUPPORT AND ESCALATED SUPPORT SERVICES FOR BUSINESSES' CUSTOMER SERVICE

TER; RETURNED MERCHANDISE MANAGEMENT, NAMELY, RETURN MERCHANDISE AUTHORIZATION (U.S. CLS. 100, 101 AND 102).

CLASS 36—INSURANCE AND FINANCIAL

FOR ADMINISTRATION OF EMPLOYEE INSURANCE AND FINANCE BENEFIT PLANS, EMPLOYEE PENSION PLANS, EMPLOYEE WELFARE BENEFIT PLANS FOR OTHERS; CREDIT CARD VERIFICATION; DEBT COLLECTION AGENCIES; FINANCIAL DUE DILIGENCE SUPPORT SERVICES; FOREIGN EXCHANGE TRANSACTIONS; ADVICE RELATING TO INVESTMENTS; ONLINE BANKING SERVICES; CLAIMS PROCESSING, NAMELY, INSURANCE CLAIMS PROCESSING; LOAN PROCESSING, NAMELY, PROCESSING LOAN APPLICATIONS; CREDIT CARD PAYMENT PROCESSING SERVICES; FINANCIAL DUE DILIGENCE SERVICES (U.S. CLS. 100, 101 AND 102).

CLASS 38—COMMUNICATION

FOR VOICE CHAT SERVICES (U.S. CLS. 100, 101 AND 104).

CLASS 41—EDUCATION AND ENTERTAINMENT

FOR SPECIAL EVENT PLANNING; TRAINING SERVICES, NAMELY, CORPORATE TRAINING IN THE FIELDS OF DIVERSITY TRAINING, LEADERSHIP DEVELOPMENT, MANAGEMENT TRAINING AND SALES TEAM BUILDING TRAINING; EDUCATION SERVICES, NAMELY, PROVIDING WEB-BASED TRAINING PROGRAMS IN THE FIELDS OF HUMAN CAPITAL MANAGEMENT, STAFFING AND EMPLOYMENT SERVICES; EDUCATIONAL SERVICES, NAMELY, PROVIDING TECHNICAL TRAINING IN THE FIELDS OF HUMAN CAPITAL MANAGEMENT, STAFFING, EMPLOYMENT SERVICES, COMPUTER SERVICES AND PROCUREMENT SERVICES; CUSTOM WRITING AND TRANSLATION SERVICES FOR OTHERS, NAMELY, CREATIVE WRITING AND WRITING OF NEWS ARTICLES FOR JOURNALS, ALL OTHER THAN FOR PUBLICITY OR ADVERTISING; WRITTEN TEXT EDITING AND PROOFREADING; DEVELOPING EDUCATIONAL MANUALS FOR OTHERS FOR OTHERS IN THE FIELDS OF HUMAN CAPITAL MANAGEMENT, STAFFING, EMPLOYMENT SERVICES, COMPUTER SERVICES AND PROCUREMENT SERVICES (U.S. CLS. 100, 101 AND 107).

CLASS 42—SCIENTIFIC AND COMPUTER SERVICES

FOR DATA CONVERSION, NAMELY, CONVERSION OF DATA FROM PHYSICAL TO ELECTRONIC MEDIA OR FROM ONE MEDIA TO ANOTHER; CONDUCTING OF FEASIBILITY STUDIES; TECHNICAL WRITING FOR OTHERS; GRAPHIC DESIGN SERVICES FOR OTHER, NAMELY, USING 3D GRAPHICS, ANIMATION, AUDIO AND VIDEO FOR BANNER ADS, BROCHURES, BUSINESS CARDS AND LETTERHEADS, CORPORATE IDENTITY DESIGNS, DESKTOP PUBLISHING, ICONS, ILLUSTRATIONS, LOGOS, GRAPHICS FOR USE WITH MUSIC, PACKAGE DESIGN, PAGE LAYOUT, PAINTING, PHOTO RETOUCHING, PHOTOGRAPHY, POSTER DESIGN, PRESENTATIONS, PRINT ADS, PRODUCT DESIGN, SIGNAGE AND STATIONERY; RESEARCH AND DEVELOPMENT IN THE FIELDS OF INFORMATION TECHNOLOGY AND COMPUTER SOFTWARE, NAMELY, OF ALPHA AND BETA PROGRAMS, APPLICATION DEVELOPMENT, APPLICATION PORTING, BUSINESS INTELLIGENCE, CLIENT/SERVER APPLICATIONS, CODE REVIEW, SOFTWARE CUSTOMIZATIONS, DATA CONVERSIONS, DATA PROCESSING, DATABASE DEVELOPMENT AND DESIGN, DOT NET APPLICATIONS, ENTERPRISE SYSTEMS, FEASIBILITY STUDIES, FUNCTIONAL SPECIFICATIONS, INTERNET/WEB APPLICATIONS, COMPUTER OPERATING SYSTEM DEVELOPMENT, MAINFRAMES, MAINTENANCE AND PATCHES, N-TIER APPLICATIONS, PERSONAL DIGITAL ASSISTANTS (PDA), COMPUTER PROGRAMMING AND PROTOTYPING; PROVIDING QUALITY ASSURANCE SERVICES IN THE FIELD OF

DATA CONVERSION AND COMPUTER SERVICES; DEVELOPMENT OF STRUCTURED QUERY LANGUAGE FOR OTHERS; DRAFTING TECHNICAL SPECIFICATIONS; PROVIDE PRODUCT TESTING SERVICES FOR OTHERS; COMPUTER PROGRAMMING; WEB DESIGN AND DEVELOPMENT SERVICES, NAMELY, E-COMMERCE WEBSITES; COMPUTERIZED ANIMATION DESIGN FOR OTHERS; SEARCH ENGINE OPTIMIZATION SERVICES, NAMELY, CARRYING OUT OPTIMIZATION SERVICES FOR OTHERS; WEB SITE DESIGN, DEVELOPMENT, HOSTING, PROGRAMMING, AND WEBSITE MAINTENANCE; CUSTOMER SERVICES AND TECHNICAL SUPPORT SERVICES FOR COMPUTER HARDWARE AND SOFTWARE, NAMELY, HELP DESK SERVICES; DATA CONVERSION OF COMPUTER PROGRAM DATA OR INFORMATION; COMPUTER SYSTEM ADMINISTRATION SERVICES FOR OTHERS, NAMELY, ACTIVITY MONITORING FOR PERFORMANCE IMPROVEMENT, SPAM FILTERING SERVICES TO PREVENT UNSOLICITED MESSAGES, VIRUS PROTECTION SERVICES, APPLICATION PERFORMANCE MONITORING, BACK-UP SERVICES FOR COMPUTER HARD DRIVE DATA, DATA MINING AND DATA WAREHOUSING; BANDWIDTH MANAGEMENT, NAMELY, MEASURING AND CONTROLLING THE COMMUNICATIONS IN THE NATURE OF TRAFFIC AND PACKETS ON A NETWORK LINK, TO AVOID FILLING THE LINK TO CAPACITY OR OVERFILLING THE LINK, WHICH WOULD RESULT IN NETWORK CONGESTION AND POOR PERFORMANCE; DATABASE ADMINISTRATION, NAMELY, MANAGING COMPUTER DATABASES FOR OTHERS; COMPUTER SOFTWARE AND HARDWARE SUPPORT SERVICES, NAMELY, HELP DESK SERVICES; DESIGNING NETWORK ARCHITECTURE; COMPUTER SOFTWARE SUPPORT SERVICES, COMPUTER SOFTWARE MAINTENANCE; COMPUTER TECHNOLOGY SUPPORT SERVICES, NAMELY, HELP DESK SERVICES; TECHNICAL SUPPORT SERVICES, NAMELY, TROUBLESHOOTING IN THE NATURE OF DIAGNOSING COMPUTER HARDWARE AND SOFTWARE ISSUES; COMPUTER HARDWARE MONITORING SERVICES WHICH TRACKS THE PERFORMANCE OF SERVER FARMS, CLUSTERS, AND GROUP CONFIGURATIONS (U.S. CLS. 100 AND 101).

SN 85-041,555, HEINEKEN BROUWERIJEN B.V., AMSTERDAM, NETHERLANDS, FILED 5-18-2010.

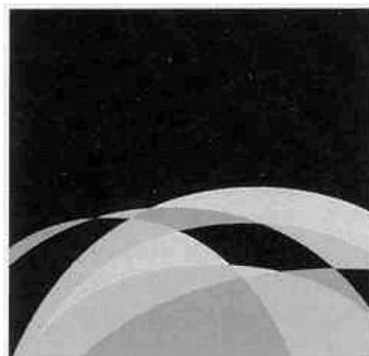

PRIORITY CLAIMED UNDER SEC. 44(D) ON ERPN CMNTY TM OFC APPLICATION NO. 008964587, FILED 3-18-2010, REG. NO. 008964587, DATED 9-2-2010, EXPIRES 3-18-2020.

THE MARK CONSISTS OF FANCIFUL ARCHES ON A SQUARE BACKGROUND.

CLASS 45—PERSONAL AND LEGAL SERVICES

FOR FRAUD DETECTION SERVICES IN THE FIELD OF CREDIT CARDS FOR ON-LINE PURCHASING AND IN THE FIELD OF HEALTH CARE INSURANCE; STATUTORY FILING, NAMELY, PREPARING AND FILING INCORPORATION PAPERS AND PUBLIC DOCUMENT FILING SERVICES FOR CORPORATIONS AND BUSINESSES; COMPUTER SOFTWARE LICENSING; LEGAL SUPPORT RELATED SERVICES, NAMELY, LITIGATION SUPPORT, PARALEGAL SUPPORT, AND CASE LAW RESEARCH IN THE FIELDS OF CONTRACTS AND AGREEMENTS, COPYRIGHTS, CUSTOMER AND VENDOR LEGAL CORRESPONDENCE, CUSTOMER AND VENDOR NEGOTIATIONS, EMPLOYMENT, ENVIRONMENTAL REGULATIONS, IMMIGRATION FORMS, INCORPORATION, PATENTS, POLICY ENFORCEMENT, REGULATORY COMPLIANCE, TAXATION AND TRADEMARK REGISTRATION; MONITORING OF COMPUTERS AND COMPUTER SYSTEMS FOR SECURITY PURPOSES; CONDUCTING COMPUTER POLICY ENFORCEMENT SERVICES, NAMELY, MONITORING AND REPORTING OF UNAUTHORIZED COMPUTER USE BY EMPLOYEES OF OTHERS (U.S. CLS. 100 AND 101).

MARTHA FROMM, EXAMINING ATTORNEY

CLASS 32—LIGHT BEVERAGES

FOR BEER; FRUIT BEER; ALE; BITTER BEER; LAGER; STOUT; PORTER; SHANDY; MINERAL WATER; FRUIT FLAVORED BEER; VEGETABLE FLAVORED BEER; APPLE BEER; AERATED WATER; FRUIT FLAVORED DRINKS; FRUIT JUICES; VEGETABLE FLAVORED DRINKS; VEGETABLE JUICES; CORDIALS; NON-ALCOHOLIC MIXTURES, NAMELY, BEER, FRUIT BEER, FRUIT FLAVORED BEER; PREPARATIONS FOR MAKING ANY OF THE AFORESAID (U.S. CLS. 45, 46 AND 48).

CLASS 33—WINES AND SPIRITS

FOR ALCOHOLIC BEVERAGES EXCEPT BEER; HARD CIDER; PERRY; WINES; SPIRITS; LIQUEURS; PREPARED ALCOHOLIC COCKTAILS; ALCOHOLIC EXTRACTS; ALCOHOLIC ESSENCES; ALCOHOLIC CARBONATE BEVERAGES EXCEPT BEER; ALCOHOLIC BEVERAGES CONTAINING FRUIT, FRUIT JUICE AND FRUIT ESSENCES; ALCOHOLIC BEVERAGES CONTAINING VEGETABLES, VEGETABLE JUICE AND VEGETABLE ESSENCE; ALCOHOLIC COCKTAIL MIXTURES CONTAINING ANY OF THE AFORESAID; ALCOHOLIC PREPARATIONS FOR MAKING ANY OF THE AFORESAID (U.S. CLS. 47 AND 49).

WILLIAM VERHOSEK, EXAMINING ATTORNEY

SN 85-041,558. HEINEKEN BROUWERIJEN B.V., AMSTERDAM, NETHERLANDS, FILED 5-18-2010.



THE MARK CONSISTS OF A DEPICTION OF A PERSON HOLDING A BOW ON A RECTANGLE BACKGROUND.

CLASS 32—LIGHT BEVERAGES

FOR BEER; FRUIT BEER; ALE; BITTER BEER; LAGER; STOUT; PORTER; SHANDY; MINERAL WATER; FRUIT FLAVORED BEER; VEGETABLE FLAVORED BEER; APPLE BEER; AERATED WATER; FRUIT FLAVORED DRINKS; FRUIT JUICES; VEGETABLE FLAVORED DRINKS; VEGETABLE JUICES; CORDIALS; NON-ALCOHOLIC MIXTURES, NAMELY, BEER, FRUIT BEER, FRUIT FLAVORED BEER; PREPARATIONS FOR MAKING ANY OF THE AFORESAID (U.S. CLS. 45, 46 AND 48).

CLASS 33—WINES AND SPIRITS

FOR ALCOHOLIC BEVERAGES EXCEPT BEER; HARD CIDER; PERRY; WINES; SPIRITS; LIQUEURS; PREPARED ALCOHOLIC COCKTAILS; ALCOHOLIC EXTRACTS; ALCOHOLIC ESSENCES; ALCOHOLIC CARBONATE BEVERAGES EXCEPT BEER; ALCOHOLIC BEVERAGES CONTAINING FRUIT, FRUIT JUICE AND FRUIT ESSENCES; ALCOHOLIC BEVERAGES CONTAINING VEGETABLES, VEGETABLE JUICE AND VEGETABLE ESSENCE; ALCOHOLIC COCKTAIL MIXTURES CONTAINING ANY OF THE AFORESAID; ALCOHOLIC PREPARATIONS FOR MAKING ANY OF THE AFORESAID (U.S. CLS. 47 AND 49).

WILLIAM VERHOSEK, EXAMINING ATTORNEY

SN 85-043,569. GRIPPLE LIMITED, SHEFFIELD, GREAT BRITAIN, FILED 5-20-2010.



OWNER OF ERPN CMNTY TM OFC REG. NO. 009097254, DATED 11-25-2010, EXPIRES 5-11-2020.
OWNER OF U.S. REG. NO. 3,329,193.
THE MARK CONSISTS OF A STYLIZED VERSION OF THE LETTER "G".

CLASS 6—METAL GOODS

FOR (BASED ON USE IN COMMERCE) CONNECTORS AND FASTENING DEVICES, NAMELY, SELF-LOCKING WIRE ROPE GRIPS FOR JOINING AND SECURING WIRES, ROPES AND CABLES, ALL BEING MADE WHOLLY OR PRINCIPALLY OF COMMON METAL; GOODS FOR SALE IN KIT FORM, FOR SUSPENSION OF EQUIPMENT AND FOR FORMING GUY ROPES AND STAYS FOR POSTS AND MASTS, COMPRISING WIRE ROPES AND WIRE ROPE CONNECTORS OF COMMON METAL; EYES, EXPANDABLE ANCHORS, TOGGLE FIXINGS AND GROUND-ENGAGING ANCHORING DEVICES, ALL OF COMMON METAL AND ALL FOR USE WITH AFORESAID KITS (U.S. CLS. 2, 12, 13, 14, 23, 25 AND 50).

FIRST USE 12-31-2002; IN COMMERCE 10-29-2009.

CLASS 8—HAND TOOLS

FOR (BASED ON 44(E)) HAND-HELD TENSIONING DEVICE IN THE NATURE OF A TOOL USED FOR TENSIONING AND RELEASING FENCE WIRES, GUY ROPES AND STAYS, AND FOR ADJUSTING THE POSITION OF EQUIPMENT SUSPENDED BY KITS COMPRISING WIRE ROPES AND WIRE ROPE CONNECTING DEVICES (U.S. CLS. 23, 28 AND 44).

DOMINICK J. SALEMI, EXAMINING ATTORNEY

SN 85-048,021. SNR DENTON US LLP, CHICAGO, IL. AND SNR DENTON UK LLP, LONDON, UNITED KINGDOM, FILED 5-26-2010.

SNR DENTON

THE MARK CONSISTS OF STANDARD CHARACTERS WITHOUT CLAIM TO ANY PARTICULAR FONT, STYLE, SIZE, OR COLOR.

PRIORITY CLAIMED UNDER SEC. 44(D) ON UNITED KINGDOM APPLICATION NO. 2549257, FILED 5-26-2010, REG. NO. 2549257, DATED 11-26-2010, EXPIRES 5-26-2020.

CLASS 16—PAPER GOODS AND PRINTED MATTER

FOR PRINTED MATTER, NAMELY, PRINTED PUBLICATIONS IN THE NATURE OF BROCHURES, MANUALS, BOOKS, BOOKLETS, NEWSLETTERS, REPORTS, AND PRINTED INSTRUCTIONAL AND TEACHING MATERIALS OTHER THAN APPARATUS AND STATIONERY, ALL OF THE AFORESAID GOODS RELATING TO LEGAL MATTERS, ISSUES, AFFAIRS AND SERVICES (U.S. CLS. 2, 5, 22, 23, 29, 37, 38 AND 50).

CLASS 41—EDUCATION AND ENTERTAINMENT

FOR ARRANGING AND CONDUCTING OF EDUCATIONAL SEMINARS AND CONFERENCES IN THE FIELD OF LEGAL MATTERS, ISSUES, AFFAIRS AND SERVICES; EDUCATION AND TRAINING SERVICES, NAMELY, CLASSES IN THE FIELD OF LEGAL MATTERS, ISSUES, AFFAIRS AND SERVICES; PREPARATION OF EDUCATIONAL REPORTS IN THE FIELD OF LEGAL MATTERS, ISSUES, AFFAIRS AND SERVICES; AND PROVIDING ADVISORY SERVICES ALL RELATING TO THE AFORESAID SERVICES (U.S. CLS. 100, 101 AND 107).

CLASS 45—PERSONAL AND LEGAL SERVICES

FOR LEGAL SERVICES; LEGAL RESEARCH SERVICES; PROVIDING INFORMATION RELATING TO LEGAL MATTERS; ISSUING OF LEGAL INFORMATION; PROVIDING LEGAL ADVICE; LEGAL CONSULTANCY SERVICES; LEGAL ENQUIRY SERVICES; LEGAL SERVICES RELATING TO BUSINESS; LEGAL SUPPORT SERVICES; PUBLIC RECORD INVESTIGATION SERVICES; PREPARATION OF LEGAL REPORTS; PATENT AND TRADEMARK AGENCY SERVICES; COMPANY FORMATION AND REGISTRATION SERVICES; PROVIDING EDUCATIONAL INFORMATION IN THE FIELD OF LEGAL MATTERS, ISSUES, AFFAIRS AND SERVICES AND PROVISION OF INFORMATION, CONSULTANCY AND ADVISORY SERVICES RELATING TO THE AFORESAID SERVICES (U.S. CLS. 100 AND 101).

MARILYN IZZI, EXAMINING ATTORNEY

SN 85-049,948. FELBER, SUZANNE S., DALLAS, TX. FILED 5-27-2010.

Lifestylist

THE MARK CONSISTS OF STANDARD CHARACTERS WITHOUT CLAIM TO ANY PARTICULAR FONT, STYLE, SIZE, OR COLOR.

OWNER OF U.S. REG. NO. 2,583,235.

CLASS 43—HOTEL AND RESTAURANT SERVICES

FOR PROVIDING AN ONLINE COMPUTER DATABASE TO CONSUMERS CONCERNING RECIPES, INGREDIENTS AND COOKING INFORMATION (U.S. CLS. 100 AND 101).

FIRST USE 12-15-1999; IN COMMERCE 8-15-2006.

CLASS 44—MEDICAL, BEAUTY AND AGRICULTURAL SERVICES

FOR PROVIDING NEWS AND INFORMATION IN THE FIELD OF PERSONAL BEAUTY (U.S. CLS. 100 AND 101).

MATTHEW KLINE, EXAMINING ATTORNEY

SN 85-051,187. MINDARK PE AB, GÖTEBORG, SWEDEN, FILED 5-31-2010.

PED

THE MARK CONSISTS OF STANDARD CHARACTERS WITHOUT CLAIM TO ANY PARTICULAR FONT, STYLE, SIZE, OR COLOR.

CLASS 9—ELECTRICAL AND SCIENTIFIC APPARATUS

FOR DOWNLOADABLE ELECTRONIC DATA FILES IN THE NATURE OF VIRTUAL CURRENCY FOR USE IN COMPUTER GAMES AND VIRTUAL ENVIRONMENTS; COMPUTER PROGRAMS IN THE FORM OF VIRTUAL CURRENCY, NAMELY, SOFTWARE FOR USE IN CREATION AND ADMINISTRATION OF VIRTUAL CURRENCY IN AN ONLINE GAMING ENVIRONMENT; COMPUTER PROGRAMS IN THE FORM OF ELECTRONIC MONEY, NAMELY, SOFTWARE FOR USE IN CREATION AND ADMINISTRATION OF ELECTRONIC MONEY IN AN ONLINE GAMING ENVIRONMENT; COMPUTER PROGRAMS IN THE FORM OF ELECTRONIC CURRENCY, NAMELY, SOFTWARE FOR USE IN CREATION AND ADMINISTRATION OF ELECTRONIC CURRENCY IN AN ONLINE GAMING ENVIRONMENT; COMPUTER PROGRAMS FOR ELECTRONIC WALLETS AND SIMILAR ELECTRONICALLY STORED VALUE SERVICES, NAMELY, SOFTWARE FOR USE IN CREATION AND ADMINISTRATION OF ELECTRONIC WALLETS AND STORED VALUE CARDS IN AN ONLINE GAMING ENVIRONMENT (U.S. CLS. 21, 23, 26, 36 AND 38).

CLASS 16—PAPER GOODS AND PRINTED MATTER

FOR PRINTED MATTER, NAMELY, SCRATCH CARDS, AND CARDS NOT MAGNETICALLY CODED FOR USE IN BUSINESS TRANSACTIONS; PRINTED GIFT VOUCHERS (U.S. CLS. 2, 5, 22, 23, 29, 37, 38 AND 50).

CLASS 35—ADVERTISING AND BUSINESS

FOR ACCOUNTING; ACCOUNTING SERVICES (U.S. CLS. 100, 101 AND 102).

CLASS 36—INSURANCE AND FINANCIAL

FOR SERVICES REGARDING ELECTRONIC WALLETS AND SIMILAR ELECTRONICALLY STORED VALUE SERVICES, NAMELY, PROVIDING ON-LINE STORED VALUE ACCOUNTS IN AN ELECTRONIC ENVIRONMENT AND STORED VALUE CARD SERVICES; PROVIDING ACCESS TO A MARKET FOR TRADING IN VIRTUAL CURRENCY AND ELECTRONIC MONEY, NAMELY, CURRENCY TRADING; BROKERAGE REGARDING VIRTUAL CURRENCY AND ELECTRONIC MONEY TRADING, NAMELY, CURRENCY BROKERAGE SERVICES AND CURRENCY TRADING SERVICES; DEBIT CARD SERVICES; ISSUANCE OF DEBIT CARDS; FINANCIAL CLEARING OF VIRTUAL MONEY AND ELECTRONIC MONEY; CREDIT CARD SERVICES; ISSUANCE OF CREDIT CARDS; ELECTRONIC FUNDS TRANSFER; ISSUING OF TOKENS OF VALUE AND GIFT VOUCHERS, NAMELY, REDEEMING SCRATCH CARDS AND VOUCHERS OF OTHERS FOR CONVERSION TO VIRTUAL CURRENCY FOR PAYMENT OF GOODS OR SERVICES; ISSUING OF CHEQUES, EXCHANGING MONEY; VERIFICATION OF CHEQUES, GIFT CREDIT VOUCHERS AND CREDIT TOKENS OF VALUE; FINANCIAL SERVICES, NAMELY, PROVIDING A VIRTUAL CURRENCY IN THE NATURE OF TOKENS FOR VALUE FOR USE BY MEMBERS OF AN ON-LINE COMMUNITY VIA A GLOBAL COMPUTER NETWORK; RESALE OF VIRTUAL CURRENCY AND ELECTRONIC MONEY ON A WEB-BASED MARKET/COMMERCIAL CENTRE, NAMELY, PROVIDING A VIRTUAL CURRENCY FOR USE BY MEMBERS OF AN ON-LINE COMMUNITY VIA A GLOBAL COMPUTER NETWORK (U.S. CLS. 100, 101 AND 102).

FIRST USE 12-4-2001; IN COMMERCE 12-4-2001.
JESSICA A. POWERS, EXAMINING ATTORNEY

SN 85-051,191. MINDARK PE AB, GÖTEBORG, SWEDEN,
FILED 5-31-2010.

PROJECT ENTROPIA DOLLAR

THE MARK CONSISTS OF STANDARD CHARACTERS WITHOUT CLAIM TO ANY PARTICULAR FONT, STYLE, SIZE, OR COLOR.

NO CLAIM IS MADE TO THE EXCLUSIVE RIGHT TO USE "DOLLAR", APART FROM THE MARK AS SHOWN.

CLASS 9—ELECTRICAL AND SCIENTIFIC APPARATUS

FOR DOWNLOADABLE ELECTRONIC DATA FILES IN THE NATURE OF VIRTUAL CURRENCY FOR USE IN COMPUTER GAMES AND VIRTUAL ENVIRONMENTS; COMPUTER PROGRAMS IN THE FORM OF VIRTUAL CURRENCY, NAMELY, SOFTWARE FOR USE IN CREATION AND ADMINISTRATION OF VIRTUAL CURRENCY IN AN ONLINE GAMING ENVIRONMENT; COMPUTER PROGRAMS IN THE FORM OF ELECTRONIC MONEY, NAMELY, SOFTWARE FOR USE IN CREATION AND ADMINISTRATION OF ELECTRONIC MONEY IN AN ONLINE GAMING ENVIRONMENT; COMPUTER PROGRAMS IN THE FORM OF ELECTRONIC CURRENCY, NAMELY, SOFTWARE FOR USE IN CREATION AND ADMINISTRATION OF ELECTRONIC CURRENCY IN AN ONLINE GAMING ENVIRONMENT; COMPUTER PROGRAMS FOR ELECTRONIC WALLETS AND SIMILAR ELECTRONICALLY STORED VALUE SERVICES, NAMELY, SOFTWARE FOR USE IN CREATION AND ADMINISTRATION OF ELECTRONIC WALLETS AND STORED VALUE CARDS IN AN ONLINE GAMING ENVIRONMENT (U.S. CLS. 21, 23, 26, 36 AND 38).

CLASS 16—PAPER GOODS AND PRINTED MATTER

FOR PRINTED MATTER, NAMELY, SCRATCH CARDS, AND CARDS NOT MAGNETICALLY CODED FOR USE IN BUSINESS TRANSACTIONS; PRINTED GIFT VOUCHERS (U.S. CLS. 2, 5, 22, 23, 29, 37, 38 AND 50).

CLASS 35—ADVERTISING AND BUSINESS

FOR ACCOUNTING; ACCOUNTING SERVICES (U.S. CLS. 100, 101 AND 102).

CLASS 36—INSURANCE AND FINANCIAL

FOR SERVICES REGARDING ELECTRONIC WALLETS AND SIMILAR ELECTRONICALLY STORED VALUE SERVICES, NAMELY, PROVIDING ON-LINE STORED VALUE ACCOUNTS IN AN ELECTRONIC ENVIRONMENT AND STORED VALUE CARD SERVICES; PROVIDING ACCESS TO A MARKET FOR TRADING IN VIRTUAL CURRENCY AND ELECTRONIC MONEY, NAMELY, CURRENCY TRADING; BROKERAGE REGARDING VIRTUAL CURRENCY AND ELECTRONIC MONEY TRADING, NAMELY, CURRENCY BROKERAGE SERVICES AND CURRENCY TRADING SERVICES; DEBIT CARD SERVICES; ISSUANCE OF DEBIT CARDS; FINANCIAL CLEARING OF VIRTUAL MONEY AND ELECTRONIC MONEY; CREDIT CARD SERVICES; ISSUANCE OF CREDIT CARDS; ELECTRONIC FUNDS TRANSFER; ISSUING OF TOKENS OF VALUE AND GIFT VOUCHERS, NAMELY, REDEEMING SCRATCH CARDS AND VOUCHERS OF OTHERS FOR CONVERSION TO VIRTUAL CURRENCY FOR PAYMENT OF GOODS OR SERVICES; ISSUING OF CHEQUES, EXCHANGING MONEY; VERIFICATION OF CHEQUES, GIFT CREDIT VOUCHERS AND CREDIT TOKENS OF VALUE; FINANCIAL SERVICES, NAMELY, PROVIDING A VIRTUAL CURRENCY IN THE NATURE OF TOKENS FOR VALUE FOR USE BY MEMBERS OF AN ON-LINE COMMUNITY VIA A GLOBAL COMPUTER NETWORK; REALE OF VIRTUAL CURRENCY AND ELECTRONIC MONEY ON A WEB-BASED MARKET/COMMERCIAL CENTRE, NAMELY, PROVIDING A VIRTUAL CURRENCY FOR USE BY MEMBERS OF AN ON-LINE COMMUNITY VIA A GLOBAL COMPUTER NETWORK (U.S. CLS. 100, 101 AND 102).

FIRST USE 12-4-2001; IN COMMERCE 12-4-2001.
JESSICA A. POWERS, EXAMINING ATTORNEY

SN 85-051,998. FERMACTIVE LLC, MANHATTAN BEACH,
CA. FILED 6-1-2010.

PRO-BEAUTY-OTIC

THE MARK CONSISTS OF STANDARD CHARACTERS WITHOUT CLAIM TO ANY PARTICULAR FONT, STYLE, SIZE, OR COLOR.

THE WORDING "PRO-BEAUTY-OTIC" HAS NO MEANING IN A FOREIGN LANGUAGE.

CLASS 3—COSMETICS AND CLEANING PREPARATIONS

FOR NON-MEDICATED SKIN LOTIONS, CLEANSER, TONERS, AND COSMETICS FOR TOPICAL USE CONTAINING PROBIOTIC BENEFICIAL BACTERIA COMPOSED OF FERMENTED COMPOSITIONS DERIVED FROM VEGETABLE, GREENS, GRAINS, FRUIT, HERBS, ALGAE AND PROTEINS (U.S. CLS. 1, 4, 6, 50, 51 AND 52).

CLASS 5—PHARMACEUTICALS

FOR PROBIOTIC NUTRITIONAL AND DIETARY SUPPLEMENTS IN THE FORM OF FUNCTIONAL DRINKS AND POWDERED DRINK MIX CONTAINING BENEFICIAL BACTERIA RESULTING FROM FERMENTED COMPOSITIONS SUCH AS GREENS, GRAINS, FRUITS, VEGETABLES, HERBS, ALGAE, AND PROTEINS (U.S. CLS. 6, 18, 44, 46, 51 AND 52).

ELISSA GARBER KON, EXAMINING ATTORNEY

SN 85-057,611. MASTER LOCK COMPANY LLC, OAK CREEK, WI. FILED 6-8-2010.

MASTER

THE MARK CONSISTS OF STANDARD CHARACTERS WITHOUT CLAIM TO ANY PARTICULAR FONT, STYLE, SIZE, OR COLOR.

OWNER OF U.S. REG. NOS. 230,311 AND 1,643,334.

CLASS 9—ELECTRICAL AND SCIENTIFIC APPARATUS

FOR ELECTRIC, ELECTRONIC AND ELECTRO-MECHANICAL SECURITY DEVICES FOR DOORS, NAMELY, DOOR OPENERS, DOOR CLOSERS, DOOR LOCKS, FIRE ALARM CONTROLS, INTELLIGENT ACCESS CONTROLS, LOCKING AND UNLOCKING CONTROLS; SOLENOID LOCKS; AUDIBLE SIGNAL SENSING DOOR LOCKS; AUDIBLE SIGNAL GENERATION KEYS AND KEY PARTS; ELECTRIC DOOR OPENERS AND DOOR CLOSERS AND REPLACEMENT AND COMPONENT PARTS THEREFOR; MECHANICALLY ACTIVATED OR ELECTRONICALLY CONTROLLED EMERGENCY DOOR LOCKS, NAMELY, PANIC/ANTI-PANIC DOOR LOCKS AND EMERGENCY EXIT LOCKS; EMERGENCY DOOR AND EXIT INSTALLATIONS, NAMELY, ELECTRIC, ELECTROMOTIVE OR MOTORIZED BOLTS, ELECTRONIC SWITCHES AND CONTROL CABINETS FOR REGULATING ELECTRIC, ELECTROMOTIVE OR MOTORIZED BOLTS AND ELECTRONIC SWITCHES; ELECTRONIC GLASS BREAK SENSORS, ELECTRONIC VIBRATION SENSORS, ELECTRONIC MOTION SENSITIVE SWITCHES; ACCESS CONTROL AND ALARM MONITORING SYSTEMS; ELECTRICALLY OPERATED AUDIO AND VISUAL PERSONAL SECURITY ALARMS; SAFETY EQUIPMENT, NAMELY, SMOKE SWITCHES FOR FIRE DOORS; ELECTRONIC AND ELECTRIC CODE LOCKS, NAMELY, CODE LOCKS WITH KEYPADS, ELECTRIC CODE LOCKS WITH MAGNETIC ENTRY CARDS OR KEY RINGS, ELECTRONIC CODE LOCK WITH CONTACT FREE READERS, ENCODED ELECTRONIC CHIP AND MAGNETIC IDENTITY CARDS; ELECTRIC LOCKS ACTUATED BY A TIMER OR WEB-BASED ACCESS CONTROL DEVICES; PUSH BUTTON ELECTRONIC CODED SWITCHES; ACCESS CONTROL AND PERSON IDENTIFICATION INSTALLATIONS, NAMELY, BAR CODE SCANNERS, SECURITY CARD READERS AND BIOMETRIC READERS AND COMPUTER HARDWARE ASSOCIATED THEREWITH, ACCESS KEY PADS AND COMPUTER HARDWARE ASSOCIATED THEREWITH AND INTERCOMMUNICATIONS SYSTEMS, COMPRISED OF INTERCOMS; TIME-RECORDING APPARATUS, INSTRUMENTS AND INSTALLATIONS FOR STAFF TIME-RECORDING, PERFORMANCE RECORDING, PROJECT PLANNING, CAPACITY PLANNING, PROJECT CONTROL, PERSONNEL PLANNING, SERVICE AND SHIFT PLANNING, NAMELY, COMPUTERS, EVENT RECORDERS, TIME CLOCKS; COMPUTER SOFTWARE FOR FACILITY ACCESS CONTROL, VIDEO IMAGING USED IN SECURITY CONTROL AND SECURITY ALARM MONITORING AND COMPUTER HARDWARE ASSOCIATED THEREWITH; ELECTRONIC KEYS, CARD READERS AND READER MODULES, CARD PRINTERS AND REMOTE CONTROLS ASSOCIATED THEREWITH; ALL OF THE ABOVE EXCLUDING GARAGE DOOR OPENERS, COMMERCIAL DOOR OPERATORS FOR OVERHEAD ROLLING DOORS OR GATE OPERATORS (U.S. CLS. 21, 23, 26, 36 AND 38).

CLASS 42—SCIENTIFIC AND COMPUTER SERVICES

FOR ON-LINE INTER-ACTIVE SECURITY SYSTEM MANAGEMENT SERVICES THAT ALLOW USERS TO REMOTELY VIEW, MONITOR, PROGRAM, OPERATE AND CONTROL LARGE AND SMALL APPLIANCES, ELECTRICAL SYSTEMS AND SECURITY SYSTEMS IN HOMES, OFFICES AND VEHICLES VIA A MOBILE DEVICE OR PDA AND THE INTERNET (U.S. CLS. 100 AND 101).

CLASS 45—PERSONAL AND LEGAL SERVICES

FOR CENTRAL STATION ELECTRIC PROTECTION SERVICE, NAMELY, FIRE ALARM MONITORING SERVICE, NIGHT WATCHMEN'S SUPERVISORY SERVICE, INTRUDER AND BURGLAR ALARM MONITORING SERVICE (U.S. CLS. 100 AND 101).

THEODORE MCBRIDE, EXAMINING ATTORNEY

SN 85-057,618. MASTER LOCK COMPANY LLC, OAK CREEK, WI. FILED 6-8-2010.

MASTER LOCK

THE MARK CONSISTS OF STANDARD CHARACTERS WITHOUT CLAIM TO ANY PARTICULAR FONT, STYLE, SIZE, OR COLOR.

OWNER OF U.S. REG. NOS. 230,311 AND 1,643,334.

NO CLAIM IS MADE TO THE EXCLUSIVE RIGHT TO USE "LOCK", APART FROM THE MARK AS SHOWN.

CLASS 9—ELECTRICAL AND SCIENTIFIC APPARATUS

FOR ELECTRIC, ELECTRONIC AND ELECTRO-MECHANICAL SECURITY DEVICES FOR DOORS, NAMELY, DOOR OPENERS, DOOR CLOSERS, DOOR LOCKS, FIRE ALARM CONTROLS, INTELLIGENT ACCESS CONTROLS, LOCKING AND UNLOCKING CONTROLS; SOLENOID LOCKS; AUDIBLE SIGNAL SENSING DOOR LOCKS; AUDIBLE SIGNAL GENERATION KEYS AND KEY PARTS; ELECTRIC DOOR OPENERS AND DOOR CLOSERS AND REPLACEMENT AND COMPONENT PARTS THEREFOR; MECHANICALLY ACTIVATED OR ELECTRONICALLY CONTROLLED EMERGENCY DOOR LOCKS, NAMELY, PANIC/ANTI-PANIC DOOR LOCKS AND EMERGENCY EXIT LOCKS; EMERGENCY DOOR AND EXIT INSTALLATIONS, NAMELY, ELECTRIC, ELECTROMOTIVE OR MOTORIZED BOLTS, ELECTRONIC SWITCHES AND CONTROL CABINETS FOR REGULATING ELECTRIC, ELECTROMOTIVE OR MOTORIZED BOLTS AND ELECTRONIC SWITCHES; ELECTRONIC GLASS BREAK SENSORS, ELECTRONIC VIBRATION SENSORS, ELECTRONIC MOTION SENSITIVE SWITCHES; ACCESS CONTROL AND ALARM MONITORING SYSTEMS; ELECTRICALLY OPERATED AUDIO AND VISUAL PERSONAL SECURITY ALARMS; SAFETY EQUIPMENT, NAMELY, SMOKE SWITCHES FOR FIRE DOORS; ELECTRONIC AND ELECTRIC CODE LOCKS, NAMELY, CODE LOCKS WITH KEYPADS, ELECTRIC CODE LOCKS WITH MAGNETIC ENTRY CARDS OR KEY RINGS, ELECTRONIC CODE LOCK WITH CONTACT FREE READERS, ENCODED ELECTRONIC CHIP AND MAGNETIC IDENTITY CARDS; ELECTRIC LOCKS ACTUATED BY A TIMER OR WEB-BASED ACCESS CONTROL DEVICES; PUSH BUTTON ELECTRONIC CODED SWITCHES; ACCESS CONTROL AND PERSON IDENTIFICATION INSTALLATIONS, NAMELY, BAR CODE SCANNERS, SECURITY CARD READERS AND BIOMETRIC READERS AND COMPUTER HARDWARE ASSOCIATED THEREWITH, ACCESS KEY PADS AND

COMPUTER HARDWARE ASSOCIATED THEREWITH AND INTERCOMMUNICATIONS SYSTEMS, COMPRISED OF INTERCOMS; TIME-RECORDING APPARATUS, INSTRUMENTS AND INSTALLATIONS FOR STAFF TIME-RECORDING, PERFORMANCE RECORDING, PROJECT PLANNING, CAPACITY PLANNING, PROJECT CONTROL, PERSONNEL PLANNING, SERVICE AND SHIFT PLANNING, NAMELY, COMPUTERS, EVENT RECORDERS, TIME CLOCKS; COMPUTER SOFTWARE FOR FACILITY ACCESS CONTROL, VIDEO IMAGING USED IN SECURITY CONTROL AND SECURITY ALARM MONITORING AND COMPUTER HARDWARE ASSOCIATED THEREWITH; ELECTRONIC KEYS, CARD READERS AND READER MODULES, CARD PRINTERS AND REMOTE CONTROLS ASSOCIATED THEREWITH; ALL OF THE ABOVE EXCLUDING GARAGE DOOR OPENERS, COMMERCIAL DOOR OPERATORS FOR OVERHEAD ROLLING DOORS OR GATE OPERATORS (U.S. CLS. 21, 23, 26, 36 AND 38).

CLASS 42—SCIENTIFIC AND COMPUTER SERVICES

FOR ON-LINE INTER-ACTIVE SECURITY SYSTEM MANAGEMENT SERVICES THAT ALLOW USERS TO REMOTELY VIEW, MONITOR, PROGRAM, OPERATE AND CONTROL LARGE AND SMALL APPLIANCES, ELECTRICAL SYSTEMS AND SECURITY SYSTEMS IN HOMES, OFFICES AND VEHICLES VIA A MOBILE DEVICE OR PDA AND THE INTERNET (U.S. CLS. 100 AND 101).

CLASS 45—PERSONAL AND LEGAL SERVICES

FOR CENTRAL STATION ELECTRIC PROTECTION SERVICE, NAMELY, FIRE ALARM MONITORING SERVICE, NIGHT WATCHMEN'S SUPERVISORY SERVICE, INTRUDER AND BURGLAR ALARM MONITORING SERVICE (U.S. CLS. 100 AND 101).

THEODORE MCBRIDE, EXAMINING ATTORNEY

SN 85-058,562. 3717291 CANADA INC., MONTREAL, QUEBEC, CANADA, FILED 6-9-2010.

KIDIWAY

THE MARK CONSISTS OF STANDARD CHARACTERS WITHOUT CLAIM TO ANY PARTICULAR FONT, STYLE, SIZE, OR COLOR.

PRIORITY CLAIMED UNDER SEC. 44(D) ON CANADA APPLICATION NO. 1465079, FILED 1-8-2010, REG. NO. TMA798,102, DATED 5-20-2011, EXPIRES 5-20-2026.

CLASS 3—COSMETICS AND CLEANING PREPARATIONS

FOR HEALTH AND BEAUTY PRODUCTS FOR BABIES AND CHILDREN, NAMELY, BABY SHAMPOO, BABY WIPES, BABY BUBBLE BATH, BABY HAND SOAP, BABY LOTION, BABY OIL, BABY POWDERS, BABY HAIR CONDITIONERS (U.S. CLS. 1, 4, 6, 50, 51 AND 52).

CLASS 6—METAL GOODS

FOR METAL SAFETY GATES FOR CHILDREN (U.S. CLS. 2, 12, 13, 14, 23, 25 AND 50).

CLASS 8—HAND TOOLS

FOR CUTLERY, NAMELY, KNIVES, FORKS AND SPOONS FOR BABIES AND CHILDREN (U.S. CLS. 23, 28 AND 44).

CLASS 9—ELECTRICAL AND SCIENTIFIC APPARATUS

FOR BABY MONITORS (U.S. CLS. 21, 23, 26, 36 AND 38).

CLASS 10—MEDICAL APPARATUS

FOR BABY BOTTLES, BABY NURSERS, BABY PACIFIERS, AND TEETHING RINGS (U.S. CLS. 26, 39 AND 44).

CLASS 11—ENVIRONMENTAL CONTROL APPARATUS

FOR LIGHTING, NAMELY, LIGHTING FIXTURES, TABLE LAMPS, ELECTRIC NIGHT LIGHTS, AND FLASHLIGHTS; BABY BOTTLE STERILIZERS, ELECTRIC BABY BOTTLE HEATERS (U.S. CLS. 13, 21, 23, 31 AND 34).

CLASS 12—VEHICLES

FOR BABY CARRIAGES, BABY STROLLERS; BOOSTER SEATS FOR USE IN VEHICLES (U.S. CLS. 19, 21, 23, 31, 35 AND 44).

CLASS 16—PAPER GOODS AND PRINTED MATTER

FOR BOOKS, NAMELY, BABY BOOKS, CHILDREN'S BOOKS, CHILDREN'S ACTIVITY BOOKS (U.S. CLS. 2, 5, 22, 23, 29, 37, 38 AND 50).

CLASS 18—LEATHER GOODS

FOR BABY UMBRELLAS, BABY BOUNCERS, BABY CARRYING BAGS, BABY BACKPACKS, AND BABY DIAPER BAGS (U.S. CLS. 1, 2, 3, 22 AND 41).

CLASS 20—FURNITURE AND ARTICLES NOT OTHERWISE CLASSIFIED

FOR BABY AND CHILDREN'S PRODUCTS, NAMELY, BABY FURNITURE, NAMELY, BEDROOM FURNITURE, BABY CRIBS, TABLES AND CHAIRS, NIGHTSTANDS, ARMOIRES, BEDS, DESKS, AND TOY CHESTS; WINDOW COVERINGS, NAMELY, INTERIOR WINDOW COVERINGS, NAMELY, VERTICAL AND HORIZONTAL LOUVERS; BABY BOOSTER SEATS; BABY CHANGING MATS, BABY CHANGING TABLES, BABY WALKERS, HIGH-CHAIRS; NON-METAL SAFETY GATES FOR BABIES AND CHILDREN; PLAYPENS (U.S. CLS. 2, 13, 22, 25, 32 AND 50).

CLASS 21—HOUSEWARES AND GLASS

FOR BABY BATH TUBS; TRAINING CUPS FOR BABIES AND CHILDREN; PLATES FOR BABIES AND CHILDREN (U.S. CLS. 2, 13, 23, 29, 30, 33, 40 AND 50).

CLASS 24—FABRICS

FOR TOWELS; BEDDING, NAMELY, BABY BEDDING, NAMELY, BUNDLE BAGS, SWADDLING BLANKETS, CRIB BUMPERS, FITTED CRIB SHEETS, CRIB SKIRTS, CRIB BLANKETS, AND DIAPER CHANGING PAD COVERS NOT OF PAPER; QUILTS; BED SHEETS; PILLOWCASES; BLANKETS; SHOWER CURTAINS; WINDOW COVERING, NAMELY, FABRIC WINDOW COVERINGS AND TREATMENTS, NAMELY, CURTAINS, DRAPERIES, SHEERS, SWAGS, WINDOW SHADES AND VALANCES (U.S. CLS. 42 AND 50).

CLASS 25—CLOTHING

FOR BABY AND CHILDREN'S CLOTHING, NAMELY, BABY LAYETTES FOR CLOTHING, BABY BUNTING, BABY BIBS NOT OF PAPER, HATS FOR INFANTS, BABIES' AND CHILDREN'S PANTS, SHIRTS, POLO SHIRTS T-SHIRTS, SWEATSHIRTS, DRESSES, SKIRTS, SHOES, BOOTS, SANDALS, SOCKS, SNOWSUITS, COATS, PAJAMAS, UNDERWEAR (U.S. CLS. 22 AND 39).

CLASS 27—FLOOR COVERINGS

FOR RUGS, BATH RUGS (U.S. CLS. 19, 20, 37, 42 AND 50).

CLASS 28—TOYS AND SPORTING GOODS

FOR TOYS, NAMELY, BABY MULTIPLE ACTIVITY TOYS, BATH TOYS, CONSTRUCTION TOYS, CRIB TOYS, EDUCATIONAL TOYS FOR TEACHING MATHEMATICS, LANGUAGE, COLORS AND SHAPES TO CHILDREN, NAMELY, MANIPULATIVE BLOCKS, FLASH CARDS, ILLUSTRATED WALL MAP, INTERACTIVE ELECTRONIC BOOKS; MECHANICAL TOYS, MUSICAL TOYS, PLUSH TOYS, RIDE-ON TOYS, AND SQUEEZABLE SQUEAKING TOYS; BABY SWINGS (U.S. CLS. 22, 23, 38 AND 50).

CLASS 35—ADVERTISING AND BUSINESS

FOR RETAIL STORE SERVICES AND WHOLESALE DISTRIBUTORSHIP SERVICES IN THE FIELD OF BABIES' AND CHILDREN'S HEALTH AND BEAUTY PRODUCTS, SAFETY PRODUCTS, PLATES AND CUTLERY, FURNITURE, DECORATIONS, BEDDING, CLOTHING, BOOKS AND TOYS; IMPORT AND EXPORT AGENCIES, ON-LINE RETAIL STORE SERVICES AND MAIL ORDER SERVICES IN THE FIELD OF BABIES' AND CHILDREN'S HEALTH AND BEAUTY PRODUCTS, SAFETY PRODUCTS, PLATES AND CUTLERY, FURNITURE, DECORATION, BEDDING, CLOTHING, BOOKS AND TOYS (U.S. CLS. 100, 101 AND 102).

INGRID C. EULIN, EXAMINING ATTORNEY

SN 85-060,451. JANCZ-URBAN, VELYA, WOODBURY, CT. FILED 6-11-2010.



THE MARK CONSISTS OF A BIRD WITH A FANCIFUL DESIGN ON A BRANCH OVER THE WORDS "CHICA PEEPS".

THE ENGLISH TRANSLATION OF "CHICA" IN THE MARK IS GIRL.

CLASS 4—LUBRICANTS AND FUELS

FOR CANDLES (U.S. CLS. 1, 6 AND 15).

CLASS 21—HOUSEWARES AND GLASS

FOR WINE GLASSES, MUGS (U.S. CLS. 2, 13, 23, 29, 30, 33, 40 AND 50).

KATHY DE JONGE, EXAMINING ATTORNEY

SN 85-062,957. AUTOMOTIVE TECHNOLOGIES, INC., MIDDLETOWN, CT. FILED 6-15-2010.

WIRELESS ZONE

THE MARK CONSISTS OF STANDARD CHARACTERS WITHOUT CLAIM TO ANY PARTICULAR FONT, STYLE, SIZE, OR COLOR.

OWNER OF U.S. REG. NOS. 2,881,706, 3,022,935 AND OTHERS.

CLASS 9—ELECTRICAL AND SCIENTIFIC APPARATUS

FOR DOWNLOADABLE ELECTRONIC PUBLICATIONS IN THE NATURE OF TRAINING MATERIALS, TRAINING MANUALS, AND TRAINING BOOKS IN THE FIELDS OF FRANCHISE START-UP, OPERATIONS, CUSTOMER SERVICE, AND MARKETING SUPPORT; ALL FOR FRANCHISEES (U.S. CLS. 21, 23, 26, 36 AND 38).

FIRST USE 6-29-2009; IN COMMERCE 6-29-2009.

CLASS 41—EDUCATION AND ENTERTAINMENT

FOR EDUCATIONAL SERVICES, NAMELY, PROVIDING TRAINING IN THE FIELDS OF FRANCHISE START-UP, OPERATIONS, CUSTOMER SERVICE, AND MARKETING SUPPORT; ALL FOR FRANCHISEES; NON-DOWNLOADABLE ELECTRONIC PUBLICATIONS IN THE NATURE OF TRAINING MATERIALS, TRAINING MANUALS, AND TRAINING BOOKS IN THE FIELDS OF FRANCHISE START-UP, OPERATIONS, CUSTOMER SERVICE, AND MARKETING SUPPORT; ALL FOR FRANCHISEES (U.S. CLS. 100, 101 AND 107).

FIRST USE 12-31-2004; IN COMMERCE 12-31-2004.

MICHAEL SOUDERS, EXAMINING ATTORNEY

SN 85-063,459. SIEMENS ENTERPRISE COMMUNICATIONS GMBH & CO. KG, MUNCHEN, FED REP GERMANY, FILED 6-15-2010.

MYCOR

THE MARK CONSISTS OF STANDARD CHARACTERS WITHOUT CLAIM TO ANY PARTICULAR FONT, STYLE, SIZE, OR COLOR.

PRIORITY CLAIMED UNDER SEC. 44(D) ON FED REP GERMANY APPLICATION NO. 302009074222, FILED 12-16-2009, REG. NO. 302009074222, DATED 8-23-2010, EXPIRES 12-31-2019.

CLASS 35—ADVERTISING AND BUSINESS

FOR COMMUNICATION SERVICES IN THE NATURE OF OPERATION OF COMMUNICATION SYSTEMS AND NETWORKS FOR OTHERS, NAMELY, OPERATING COMMUNICATION SYSTEMS AND NETWORKS OF CORPORATION AND TELECOMMUNICATION CARRIERS THAT ARE FOR USE IN ELECTRONIC TRANSMISSION OF VOICE, DATA, IMAGES, SOUND AND DOCUMENTS VIA COMPUTER TERMINALS, ELECTRONIC MAILING, FACSIMILE TRANSMISSION, TRANSMISSION OF SHORT MESSAGES (SMS), VOICE BOX SERVICES, AND SERVICES FOR FORWARDING TELEPHONE-CALLS AND CONFERENCE CALL SERVICES (U.S. CLS. 100, 101 AND 102).

CLASS 38—COMMUNICATION

FOR COMMUNICATION SERVICES, NAMELY, TRANSMISSION OF VOICE, DATA, IMAGES, SOUND AND DOCUMENTS BY MEANS OF TELECOMMUNICATION NETWORKS, PACKET-BASED COMMUNICATION NETWORKS OR CIRCUIT SWITCHED COMMUNICATION NETWORKS; ELECTRONIC MAIL SERVICES; FACSIMILE COMMUNICATION; PROVISION OF SHORT MESSAGE SERVICES; VOICE BOX SERVICES, NAMELY, AUTOMATED TELEPHONE VOICE MESSAGE SERVICES; CALL FORWARDING SERVICES; RENTAL OF EQUIPMENT FOR PACKET-BASED AND CIRCUIT SWITCHED TELECOMMUNICATIONS (U.S. CLS. 100, 101 AND 104).

ERIN FALK, EXAMINING ATTORNEY

SN 85-063,501. ALLIED DAIRY PRODUCTS, INC., MILBURN, NJ. FILED 6-15-2010.

THINKING OUTSIDE THE BARN

THE MARK CONSISTS OF STANDARD CHARACTERS WITHOUT CLAIM TO ANY PARTICULAR FONT, STYLE, SIZE, OR COLOR.

CLASS 36—INSURANCE AND FINANCIAL

FOR HEDGING SERVICES, NAMELY, PROVIDING COMMODITY HEDGING SERVICES IN THE FIELD OF DAIRY PRODUCTS, NAMELY, CHEESE, BUTTER, CASEIN AND CASEINATES, MILK POWDERS, WHEY, DAIRY PRODUCTS AND DAIRY BY-PRODUCTS (U.S. CLS. 100, 101 AND 102).

FIRST USE 6-15-2009; IN COMMERCE 6-15-2009.

CLASS 39—TRANSPORTATION AND STORAGE

FOR STORAGE OF INGREDIENTS OF CHEESE, BUTTER, CASEIN AND CASEINATES, MILK POWDERS, WHEY, DAIRY PRODUCTS AND DAIRY BY-PRODUCTS FOR OTHERS; WAREHOUSING SERVICES, NAMELY, STORAGE OF INGREDIENTS OF CHEESE, BUTTER, CASEIN AND CASEINATES, MILK POWDERS, WHEY, DAIRY PRODUCTS AND DAIRY BY-PRODUCTS FOR OTHERS (U.S. CLS. 100 AND 105).

FIRST USE 6-15-2009; IN COMMERCE 6-15-2009.

CLASS 40—MATERIAL TREATMENT

FOR FOOD PROCESSING SERVICES, NAMELY, CHEESE RIPENING; FOOD PROCESSING SERVICES, NAMELY, RECLAMATION, TRIMMING, AND CUTTING INGREDIENTS OF CHEESE, BUTTER, CASEIN AND CASEINATES, MILK POWDERS, WHEY, DAIRY PRODUCTS AND DAIRY BY-PRODUCTS FOR OTHERS; CUSTOM MANUFACTURE OF INGREDIENTS OF CHEESE, BUTTER, CASEIN AND CASEINATES, MILK POWDERS, WHEY, DAIRY PRODUCTS AND DAIRY BY-PRODUCTS FOR OTHERS (U.S. CLS. 100, 103 AND 106).

FIRST USE 6-15-2009; IN COMMERCE 6-15-2009.

CLASS 42—SCIENTIFIC AND COMPUTER SERVICES

FOR CHEESE GRADING SERVICES; FOOD INSPECTION SERVICES, NAMELY, INSPECTION OF CHEESE (U.S. CLS. 100 AND 101).

FIRST USE 6-15-2009; IN COMMERCE 6-15-2009.

SETH A. RAPPAPORT, EXAMINING ATTORNEY

SN 85-064,028. GRAMPYS CHARITIES, NEW LONDON, CT. FILED 6-16-2010.



THE COLOR(S) BROWN, WHITE, BEIGE, BLACK, YELLOW, GREEN, RED AND GRAY IS/ARE CLAIMED AS A FEATURE OF THE MARK.

THE MARK CONSISTS OF A GOLFER WITH BEIGE SKIN AND WHITE HAIR, WEARING A RED CAP, YELLOW SWEATER, GREEN PANTS WITH A BLACK PLAID STRIPE PATTERN, BROWN SHOES AND WHITE EYES WITH BLACK CIRCULAR PUPILS, SWINGING A BROWN AND WHITE GOLF CLUB LOOKING DOWNRANGE WITH BLACK AND GRAY SHADOWING BENEATH HIM. ALL OF THE ELEMENTS OF THE MARK ARE OUTLINED IN BLACK.

CLASS 18—LEATHER GOODS

FOR GYM BAGS; TOTE BAGS (U.S. CLS. 1, 2, 3, 22 AND 41).

FIRST USE 0-0-2006; IN COMMERCE 0-0-2006.

CLASS 21—HOUSEWARES AND GLASS

FOR MUGS; PLASTIC WATER BOTTLES SOLD EMPTY; THERMAL INSULATED CONTAINERS FOR FOOD OR BEVERAGES (U.S. CLS. 2, 13, 23, 29, 30, 33, 40 AND 50).

FIRST USE 0-0-2006; IN COMMERCE 0-0-2006.

CLASS 25—CLOTHING

FOR APRONS; BOXER SHORTS; GOLF SHIRTS; HEADGEAR, NAMELY, CAPS; HOODED SWEAT SHIRTS; SHORT-SLEEVED OR LONG-SLEEVED T-SHIRTS; SWEAT SHIRTS; WIND RESISTANT JACKETS (U.S. CLS. 22 AND 39).

FIRST USE 0-0-2006; IN COMMERCE 0-0-2006.
TINA BROWN, EXAMINING ATTORNEY

SN 85-064,564. BIOMED REALTY TRUST, INC., SAN DIEGO, CA. FILED 6-16-2010.

UNIVERSAL FLEX LABS

THE MARK CONSISTS OF STANDARD CHARACTERS WITHOUT CLAIM TO ANY PARTICULAR FONT, STYLE, SIZE, OR COLOR.

NO CLAIM IS MADE TO THE EXCLUSIVE RIGHT TO USE "FLEX LABS", APART FROM THE MARK AS SHOWN.

CLASS 36—INSURANCE AND FINANCIAL

FOR REAL ESTATE ACQUISITION, LEASING, AND MANAGEMENT SERVICES; REAL ESTATE INVESTMENT SERVICES; REAL ESTATE INVESTMENT TRUST SERVICES (U.S. CLS. 100, 101 AND 102).

CLASS 37—CONSTRUCTION AND REPAIR

FOR REAL ESTATE DEVELOPMENT (U.S. CLS. 100, 103 AND 106).
ANDREW RHIM, EXAMINING ATTORNEY

SN 85-069,385. MINDARK PE AB, GÖTEBORG, SWEDEN, FILED 6-23-2010.

ENTROPIA
UNIVERSE

THE MARK CONSISTS OF "ENTROPIA UNIVERSE" IN STYLIZED FORM WITH DESIGN, WITH THE WORDING "ENTROPIA" APPEARING IN A BOLD HIGHLY STYLIZED FONT IN THE TOP PORTION OF THE MARK, WITH THE WORDING "UNIVERSE" IN A LESS-STYLIZED FONT IN THE BOTTOM PORTION OF THE MARK, AND WITH BOLD HORIZONTAL LINES APPEARING TO THE LEFT AND RIGHT SIDES OF "UNIVERSE".

CLASS 9—ELECTRICAL AND SCIENTIFIC APPARATUS

FOR ENTERTAINMENT COMPUTER SOFTWARE, NAMELY, COMPUTER GAME SOFTWARE, COMPUTER SOFTWARE FOR USE IN CREATING, EDITING AND SHARING VIRTUAL WORLD CONTENT, AND COMPUTER SOFTWARE FOR VISUALIZATION OF AND INTERACTION WITH AN ONLINE VIRTUAL WORLD FEATURING COMMUNICATIONS AMONG COMPUTER USERS, CHAT ROOMS, ELECTRONIC BULLETIN BOARDS, COMPUTER GAMES, ROLE PLAYING GAMES, VIRTUAL ENVIRONMENTS, EDUCATIONAL ACTIVITIES, A VIRTUAL ECONOMY AND A VIRTUAL CURRENCY FOR TRANSACTION OF VIRTUAL COMMERCE, ELECTRONIC COMMERCE, AND DELIVERY OF AUDIO, VIDEO AND MULTIMEDIA CONTENT; COMPUTER GAME PROGRAMS; VIDEO GAME SOFTWARE; ROLE PLAYING GAME SOFTWARE AND HARDWARE, NAMELY, COMPUTER JOYSTICKS; VIRTUAL REALITY GAME SOFTWARE AND HARDWARE, NAMELY, COMPUTER JOYSTICKS; INTERACTIVE COMPUTER SOFTWARE THAT PROVIDES MULTI-USER ACCESS TO AN ONLINE 3D ENVIRONMENT; GAMES, NAMELY, COMPUTER AND VIDEO GAME DISCS; ELECTRONIC NOTICE BOARDS; SOFTWARE TO ENABLE UPLOADING, POSTING AND PROVIDING ACCESS TO ELECTRONICALLY TRANSMITTED CONTENT OVER COMPUTER NETWORKS; PRE-RECORDED ANIMATED FILMS ABOUT VIRTUAL REALITY GAMING; ELECTRONIC STORED PICTURES AND IMAGES, NAMELY, DOWNLOADABLE GRAPHICS FOR MOBILE PHONES; COMPUTER GRAPHICS SOFTWARE; COMPUTER GAME SOFTWARE THAT MAY BE DOWNLOADED FROM A GLOBAL COMPUTER NETWORK; COMPUTER SOFTWARE TO ENABLE ELECTRONIC BUSINESS TRANSACTIONS VIA GLOBAL COMPUTER NETWORKS; COMPUTER SOFTWARE ENABLING USERS TO ELECTRONICALLY TRANSMIT AND RECEIVE CONTENT AND INFORMATION TO AND FROM MOBILE PHONES; COMPUTER COMMUNICATIONS SOFTWARE FOR CONNECTING USERS OF GLOBAL NETWORK (U.S. CLS. 21, 23, 26, 36 AND 38).

CLASS 41—EDUCATION AND ENTERTAINMENT

FOR DIGITAL IMAGING SERVICES; ONLINE EDUCATIONAL SERVICES, NAMELY, CONDUCTING ONLINE EXHIBITIONS AND DISPLAYS AND INTERACTIVE EXHIBITS IN THE FIELDS OF EDUCATION, CULTURE, SPORTS AND ENTERTAINMENT FOR NON-BUSINESS AND NON-COMMERCIAL PURPOSES; ENTERTAINMENT SERVICES, NAMELY, AN ON-LINE INTERACTIVE 3D VIRTUAL ENVIRONMENT, NAMELY, ON-LINE COMPUTER GAMES FOR MULTI-USERS ACCESS VIA A GLOBAL COMPUTER NETWORK; MULTI-PLAYER GAME SERVICES, NAMELY, ENTERTAINMENT SERVICES, NAMELY, PROVIDING AN ON-LINE COMPUTER GAME ELECTRONICALLY VIA A GLOBAL COMPUTER NETWORK; ORGANIZATION OF COMPETITIONS AND ON-LINE EVENTS, NAMELY, ENTERTAINMENT AND EDUCATIONAL SERVICES IN THE NATURE OF ON-LINE COMPETITIONS IN THE FIELDS OF ENTERTAINMENT, EDUCATION, CULTURE, SPORTS, AND OTHER NON-BUSINESS AND NON-COMMERCIAL FIELDS; ORGANIZATION OF EXHIBITIONS FOR CULTURAL OR EDUCATIONAL PURPOSES ACCESSED FROM GLOBAL COMMUNICATIONS NETWORKS; SERVICE FOR PROVIDING NOT DOWNLOADABLE ON-LINE ELECTRONIC PUBLICATIONS, NAMELY, ONLINE ELECTRONIC PUBLISHING OF BOOKS AND PERIODICALS; ENTERTAINMENT INFORMATION SERVICE, NAMELY, PROVIDING INFORMATION ON-LINE RELATING TO COMPUTER GAMES IN RELATIONS TO ADMINISTERING, MANAGING, TRACKING AND RECORDING TRANSACTIONS WITH VIRTUAL CURRENCIES AND VIRTUAL OBJECTS FOR USE BY PARTICIPANTS OF AN ONLINE VIRTUAL ENVIRONMENT; PROVIDING ON-LINE INFORMATION IN THE FIELD OF COMPUTER GAMING ENTERTAINMENT AND ENHANCEMENT; MULTIMEDIA ENTERTAINMENT, NAMELY, MULTIMEDIA PRODUCTION SERVICES; ENTERTAINMENT SERVICES, NAMELY, ADMINISTERING, TRACKING AND RECORDING ELECTRONIC TRANSACTIONS WITH VIRTUAL ITEMS, NAMELY, PROVIDING AN ON-LINE VIRTUAL ENVIRONMENT FOR

TRADING VIRTUAL ITEMS; CONSULTING AND PROVIDING INFORMATION REGARDING ALL AFORESAID SERVICES (U.S. CLS. 100, 101 AND 107).

SN 85-080,499. ECMA INTERNATIONAL, GENÈVE, SWITZERLAND, FILED 7-8-2010.

CLASS 42—SCIENTIFIC AND COMPUTER SERVICES

FOR SOFTWARE DESIGN, DEVELOPMENT AND MAINTENANCE AND THE UPDATING OF MULTIMEDIA AND 3D VIRTUAL ENVIRONMENT SOFTWARE IN THE FIELD OF MULTIMEDIA ENTERTAINMENT PRODUCTION; GRAPHIC ARTS DESIGN, MAINLY FOR COMPUTER GAMES AND VIRTUAL ENVIRONMENTS; HOSTING WEBSITES, MAINLY WEBSITE FEATURING A WIDE VARIETY OF END-USER SERVICES AVAILABLE VIA MULTI-USER ONLINE 3D VIRTUAL ENVIRONMENTS; APPLICATION SERVICE PROVIDER (ASP) FEATURING SOFTWARE TO ENABLE USER PARTICIPATION IN A MULTI-USER ONLINE 3D VIRTUAL ENVIRONMENT; APPLICATION SERVICE PROVIDER (ASP) FEATURING SOFTWARE TO ENABLE UPLOADING, POSTING, DISPLAYING AND PROVIDING ACCESS TO ELECTRONIC MULTIMEDIA CONTENT OVER GLOBAL COMMUNICATION NETWORKS; RENTAL OF COMPUTER SOFTWARE, MAINLY SOFTWARE WHICH PROVIDES ACCESS TO A MULTI-USER ONLINE 3D VIRTUAL ENVIRONMENT; HOSTING ON-LINE WEB FACILITIES FOR OTHERS FOR ORGANIZING AND CONDUCTING ONLINE MEETINGS, GATHERINGS, AND INTERACTIVE DISCUSSIONS; PROVIDING A WEBSITE THAT ENABLES USERS TO SUBSCRIBE TO EDUCATIONAL SERVICES AND TO ENABLE USERS TO AUTHOR AND PUBLISH INSTRUCTIONAL CONTENT FOR OTHERS; CONSULTING, TECHNICAL ADVICE AND PROVIDING INFORMATION REGARDING ALL AFORESAID SERVICES (U.S. CLS. 100 AND 101).

JESSICA A. POWERS, EXAMINING ATTORNEY

ProxZzzy

THE MARK CONSISTS OF STANDARD CHARACTERS WITHOUT CLAIM TO ANY PARTICULAR FONT, STYLE, SIZE, OR COLOR.

PRIORITY CLAIMED UNDER SEC. 44(D) ON ERPNCMNTY TM OFC APPLICATION NO. 008849606, FILED 1-15-2010, REG. NO. 008849606, DATED 7-5-2010, EXPIRES 1-15-2020.

CLASS 9—ELECTRICAL AND SCIENTIFIC APPARATUS

FOR SCIENTIFIC, NAUTICAL, SURVEYING, PHOTOGRAPHIC, CINEMATOGRAPHIC, OPTICAL, WEIGHING, MEASURING, SIGNALING, CHECKING (SUPERVISION), LIFE-SAVING AND TEACHING APPARATUS AND INSTRUMENTS, NAMELY, NETWORK INTERFACES, NETWORK ROUTERS, NETWORK SWITCHES, WIRELESS CARDS, WIRELESS ROUTERS, WIRELESS SWITCHES, NETWORK DEVICES; APPARATUS AND INSTRUMENTS FOR CONDUCTING, SWITCHING, TRANSFORMING, ACCUMULATING, REGULATING OR CONTROLLING ELECTRICITY; APPARATUS FOR RECORDING, TRANSMISSION OR REPRODUCTION OF SOUND OR IMAGES, NAMELY, NETWORK INTERFACES, NETWORK ROUTERS, NETWORK SWITCHES, WIRELESS CARDS, WIRELESS ROUTERS, WIRELESS SWITCHES, NETWORK DEVICES; AUTOMATIC VENDING MACHINES AND MECHANISMS FOR COIN-OPERATED APPARATUS; CASH REGISTERS, CALCULATING MACHINES, DATA PROCESSING EQUIPMENT AND COMPUTERS; COMPUTER HARDWARE; COMPUTER PERIPHERALS; COMPUTER SOFTWARE IN THE FIELD OF INFORMATION TECHNOLOGY, CONSUMER ELECTRONICS, NETWORKED CONSUMER GOODS, NETWORKED INDUSTRIAL GOODS, NETWORKED SERVERS AND MOBILE NETWORKS; COMPUTER OPERATING SYSTEMS; HANDHELD COMPUTERS; MAINFRAME-CLASS COMPUTERS; COMPUTER WORKSTATIONS COMPRISING NETWORK INTERFACES, NETWORK ROUTERS, NETWORK SWITCHES, WIRELESS CARDS, WIRELESS ROUTERS, WIRELESS SWITCHES, NETWORK DEVICES; KEYBOARDS; COMPUTER SERVERS, AND NETWORKED COMPUTER STORAGE DEVICES, NAMELY, STORAGE AREA NETWORKS (SANS); INTEGRATED CIRCUITS; COMPUTER INTERFACE BOARDS, COMPUTER MODEMS AND MOUSE POINTING DEVICES, NAMELY, COMPUTER MOUSE; COMPUTER PERIPHERALS; PRINTERS AND PRINTER PERIPHERALS; PRINTED CIRCUIT BOARDS CONTAINING ELECTRICAL COMPONENTS AND SOCKETS; SEMI-CONDUCTOR ELEMENTS; SILICON WAFERS AND CHIPS; ELECTRONIC NOTICE BOARDS; COMPUTER CHIPS; COMPUTER DISK DRIVES; DATA PROCESSORS; DIGITAL CAMERAS; DIGITAL VIDEO RECORDERS; FACSIMILE MACHINES; INTERNET TELEVISION HARDWARE IN THE NATURE OF NETWORK INTERFACES, NETWORK ROUTERS, NETWORK SWITCHES, WIRELESS CARDS, WIRELESS ROUTERS, WIRELESS SWITCHES, NETWORK DEVICES; MICROPROCESSORS; MICROCOMPUTERS; MINICOMPUTERS; OPTICAL SCANNERS; PHOTOCOPYING MACHINES; PERSONAL DIGITAL ASSISTANTS; PHOTOGRAPHIC CAMERAS; PHOTOGRAPHIC PROJECTORS; SLIDE PROJECTORS; RADIO PAGERS; RADIOS; SCANNERS; TELEPHONES; TELEPHONE ANSWERING MACHINES; TELEVISION SETS; TELEVISION SET TOP BOXES; VIDEO CAMERAS; VIDEO MONITORS; VOICE MESSAGING SYSTEMS; WEB TELEPHONES; WIRELESS DATA COMMUNICATIONS HARDWARE, NAMELY, NETWORK INTERFACES, NETWORK ROUTERS, NETWORK SWITCHES, WIRELESS CARDS, WIRELESS ROUTERS, WIRELESS SWITCHES, NETWORK DEVICES; COMPUTER PROGRAMS FOR TESTING COMPATIBILITY OF COMPU-

SN 85-077,295. C.B. FLEET INVESTMENT CORPORATION, WILMINGTON, DE. FILED 7-2-2010.

THE V SPOT

THE MARK CONSISTS OF STANDARD CHARACTERS WITHOUT CLAIM TO ANY PARTICULAR FONT, STYLE, SIZE, OR COLOR.

CLASS 3—COSMETICS AND CLEANING PREPARATIONS

FOR NON-MEDICATED DOUCHE; FEMININE DEODORANT SPRAY; LIQUID CLEANSING SOLUTION, NAMELY, NON-MEDICATED FEMININE HYGIENE WASH FOR EXTERNAL FEMININE HYGIENE; NON-MEDICATED FOAMING CLEANSING BATH LIQUID FOR EXTERNAL FEMININE HYGIENE; NON-MEDICATED BATH POWDER FOR EXTERNAL COSMETIC USE; NON-MEDICATED BATH AND SHOWER GEL; FEMININE HYGIENE CLEANSING TOWELETTES; AFTER SHAVE CREAMS, GELS, LIQUIDS, LOTIONS; PRE-MOISTENED COSMETIC TOWELETTES; SHAVING GELS, CREAMS, MOUSSE; DEPILATORIES (U.S. CLS. 1, 4, 6, 50, 51 AND 52).

CLASS 5—PHARMACEUTICALS

FOR MEDICATED DOUCHE; MEDICATED SHAVING PREPARATIONS IN THE NATURE OF MEDICATED AFTER SHAVE CREAMS, GELS, LIQUIDS, LOTIONS AND MEDICATED PRE-MOISTENED TOWELETTES (U.S. CLS. 6, 18, 44, 46, 51 AND 52).

CHARISMA HAMPTON, EXAMINING ATTORNEY

TER PROGRAMS; COMPUTER PROGRAMS FOR USE IN COMPUTER NETWORKING; COMPUTER PROGRAMS FOR USE IN COMPUTER EMULATION; COMPUTER PROGRAMS FOR USE IN ELECTRONIC MAIL; COMPUTER PROGRAMS FOR CREATING GRAPHICAL INTERFACES; COMPUTER PROGRAMS FOR USE IN DATABASE MANAGEMENT; COMPUTER PROGRAMS FOR DOCUMENT PROCESSING; COMPUTER PROGRAMS FOR WORD PROCESSING; COMPUTER PROGRAMS FOR PREPARING SPREADSHEETS; COMPUTER PROGRAMS FOR USE IN COMPUTER SECURITY; COMPUTER PROGRAMS FOR USE IN THE DEVELOPMENT OF COMPUTER PROGRAMS, PROGRAMMING LANGUAGES, TOOL KITS AND COMPILERS; COMPUTER PROGRAMS FOR USE IN DEVELOPING, COMPILING AND EXECUTING OTHER COMPUTER PROGRAMS ON COMPUTERS, COMPUTER NETWORKS, AND GLOBAL COMMUNICATIONS NETWORKS; COMPUTER PROGRAMS FOR USE IN NAVIGATING, BROWSING, TRANSFERRING INFORMATION, AND DISTRIBUTING AND VIEWING OTHER COMPUTER PROGRAMS ON COMPUTERS, COMPUTER NETWORKS AND GLOBAL COMMUNICATIONS NETWORKS; COMPUTER PROGRAMS FOR RECORDING, PROCESSING, RECEIVING, REPRODUCING, TRANSMITTING, MODIFYING, COMPRESSING, DECOMPRESSING, BROADCASTING, MERGING, AND/OR ENHANCING SOUND, VIDEO, IMAGES, GRAPHICS, AND/OR DATA; COMPUTER OPERATING SYSTEM PROGRAMS; COMPUTER UTILITY PROGRAMS; COMPUTER PROGRAMS FOR USE WITH COMPUTER SERVERS; COMPUTER PROGRAMS FOR USE IN TELEPHONES; COMPUTER PROGRAMS USED IN ACCESSING DATABASES; COMPUTER GAME PROGRAMS; COMPUTER PROGRAMS DOWNLOADABLE FROM GLOBAL COMPUTER NETWORKS; AND INSTRUCTIONAL MANUALS IN ELECTRONIC FORMAT SOLD THEREWITH (U.S. CLS. 21, 23, 26, 36 AND 38).

CLASS 35—ADVERTISING AND BUSINESS

FOR DATA PROCESSING SERVICES (U.S. CLS. 100, 101 AND 102).

CLASS 42—SCIENTIFIC AND COMPUTER SERVICES

FOR SCIENTIFIC AND TECHNOLOGICAL SERVICES AND RESEARCH AND DESIGN RELATING THERETO, NAMELY, NETWORKING, NETWORK TESTING IN THE FIELD OF INFORMATION TECHNOLOGY, CONSUMER ELECTRONICS, NETWORKED CONSUMER GOODS, NETWORKED INDUSTRIAL GOODS, NETWORKED SERVERS AND MOBILE NETWORKS; INDUSTRIAL ANALYSIS AND RESEARCH SERVICES IN THE FIELD OF INFORMATION TECHNOLOGY, CONSUMER ELECTRONICS, NETWORKED CONSUMER GOODS, NETWORKED INDUSTRIAL GOODS, NETWORKED SERVERS AND MOBILE NETWORKS; DESIGN AND DEVELOPMENT OF COMPUTER HARDWARE AND SOFTWARE, DEVELOPMENT OF VOLUNTARY STANDARDS FOR MANUFACTURERS OF COMMUNICATIONS TECHNOLOGY, COMPUTER HARDWARE AND SOFTWARE, AND CONSUMER ELECTRONICS; COMPUTER SERVICES, NAMELY, PROVIDING CONSULTATION SERVICES AND ADVICE IN THE FIELDS OF COMPUTERS, COMPUTER HARDWARE, COMPUTER SOFTWARE, COMPUTER PERIPHERALS, COMPUTER SYSTEMS, COMPUTER NETWORKS, COMPUTER-RELATED EQUIPMENT, COMPUTER SECURITY, INFORMATION TECHNOLOGY, ELECTRONIC COMMERCE TECHNOLOGY AND GLOBAL COMPUTER NETWORK TECHNOLOGY; LEASING SERVICES (LONG-TIME RENTAL) IN THE FIELDS OF COMPUTERS, COMPUTER HARDWARE, COMPUTER SOFTWARE, COMPUTER PERIPHERALS, COMPUTER SYSTEMS, COMPUTER NETWORKS, AND COMPUTER-RELATED EQUIPMENT; DESIGN FOR OTHERS IN THE FIELDS OF COMPUTERS, COMPUTER HARDWARE, COMPUTER SOFTWARE, COMPUTER PERIPHERALS, COMPUTER SYSTEMS, COMPUTER NETWORKS, COMPUTER-RELATED EQUIPMENT, COMPUTER SECURITY, INFORMATION TECHNOLOGY, ELECTRONIC COMMERCE TECHNOLOGY AND GLOBAL COMPUTER NETWORK TECHNOLOGY; INSTALLATION, MAINTENANCE, AND REPAIR OF COMPUTER SOFTWARE; WEBSITE DESIGN; WEBSITE

HOSTING; COMPUTER PROGRAMMING; PROVIDING ONLINE INFORMATION AND NEWS IN THE FIELD OF COMPUTERS, COMPUTER HARDWARE, COMPUTER SOFTWARE, AND TECHNOLOGY; APPLICATION SERVICE PROVIDER, NAMELY, PROVIDING, HOSTING, MANAGING, DEVELOPING, AND MAINTAINING APPLICATIONS, SOFTWARE, WEBSITES, AND DATABASES IN THE FIELDS OF COMPUTERS, COMPUTER HARDWARE, COMPUTER SOFTWARE, COMPUTER PERIPHERALS, COMPUTER SYSTEMS, COMPUTER NETWORKS, COMPUTER-RELATED EQUIPMENT, COMPUTER SECURITY, INFORMATION TECHNOLOGY, ELECTRONIC COMMERCE TECHNOLOGY AND GLOBAL COMPUTER NETWORK TECHNOLOGY, WIRELESS COMMUNICATION, MOBILE INFORMATION ACCESS, AND REMOTE DATA MANAGEMENT (U.S. CLS. 100 AND 101).

MIDGE BUTLER, EXAMINING ATTORNEY

SN 85-081,626. HOOVER & STRONG, INC., RICHMOND, VA.
FILED 7-9-2010.



THE MARK CONSISTS OF A GLOBE ENCLOSED IN A HEART-SHAPED RING NEXT TO THE WORD "HARMONY" WITH THE "O" IN "HARMONY" APPEARING AS A HEART.

CLASS 14—JEWELRY

FOR JEWELRY OBTAINED FROM, AND MANUFACTURED WITH, ECOLOGICALLY FRIENDLY METHODS AND SOURCES; DIAMONDS OBTAINED FROM CONFLICT-FREE SOURCES; DIAMONDS AND GEMS OBTAINED IN AN ETHICAL MANNER; RECYCLED PRECIOUS METALS AND PRECIOUS METAL ALLOYS (U.S. CLS. 2, 27, 28 AND 50).

FIRST USE 5-0-2007; IN COMMERCE 5-0-2007.

CLASS 35—ADVERTISING AND BUSINESS

FOR DESIGN OF ADVERTISING MATERIALS FOR OTHERS (U.S. CLS. 100, 101 AND 102).

FIRST USE 5-0-2007; IN COMMERCE 5-0-2007.

CLASS 40—MATERIAL TREATMENT

FOR JEWELRY CASTING; DIE CASTING; METAL CASTING; CUSTOM MANUFACTURE OF JEWELRY FOR OTHERS; TREATMENT OF METAL; PROVIDING A WEBSITE FEATURING INFORMATION ABOUT ENVIRONMENTALLY FRIENDLY MANUFACTURING AND RECYCLING PRACTICES IN THE JEWELRY INDUSTRY (U.S. CLS. 100, 103 AND 106).

FIRST USE 5-0-2007; IN COMMERCE 5-0-2007.

CLASS 42—SCIENTIFIC AND COMPUTER SERVICES

FOR CUSTOM DESIGN OF JEWELRY FOR OTHERS (U.S. CLS. 100 AND 101).

FIRST USE 5-0-2007; IN COMMERCE 5-0-2007.
DANIEL CAPSHAW, EXAMINING ATTORNEY

SN 85-083,390. WILLIAM HILL ORGANIZATION LIMITED,
LONDON, UNITED KINGDOM, FILED 7-13-2010.

WILLIAM HILL

THE MARK CONSISTS OF STANDARD CHARACTERS WITHOUT CLAIM TO ANY PARTICULAR FONT, STYLE, SIZE, OR COLOR.

OWNER OF ERPN CMNTY TM OFC REG. NO. 3631471,
DATED 6-27-2005, EXPIRES 1-22-2014.

OWNER OF U.S. REG. NOS. 2,871,368 AND 3,102,564.
THE NAME "WILLIAM HILL" DOES NOT IDENTIFY A LIVING INDIVIDUAL.

CLASS 9—ELECTRICAL AND SCIENTIFIC APPARATUS

FOR COMPUTER SOFTWARE FOR GAMING, GAMBLING AND BETTING; COMPUTER SOFTWARE FOR PLAYING GAMES; COMPUTER SOFTWARE FOR USE ON COMPUTER NETWORKS, INCLUDING THE INTERNET FOR GAMING, GAMBLING AND BETTING; DOWNLOADABLE ELECTRONIC PUBLICATIONS IN THE NATURE OF BOOKS, NEWSPAPERS, NEWSLETTERS, MAGAZINES, BROCHURES, BOOKLETS, PAMPHLETS AND MANUALS FEATURING GAMING, GAMBLING AND BETTING; ELECTRONIC PUBLICATIONS, NAMELY, BOOKS, NEWSPAPERS, NEWSLETTERS, MAGAZINES, BROCHURES, BOOKLETS, PAMPHLETS AND MANUALS FEATURING GAMING, GAMBLING AND BETTING RECORDED ON COMPUTER MEDIA; INFORMATION REGARDING CASINOS, GAMING, GAMBLING AND BETTING RECORDED ON COMPUTER MEDIA; ELECTRONIC NUMBER GENERATORS FOR LOTTERY GAMES AND OTHER GAMES OF SKILL AND GAMES OF CHANCE; ELECTRONIC NUMBER TERMINALS FOR LOTTERY GAMES AND OTHER GAMES OF SKILL AND GAMES OF CHANCE; CALCULATORS; MAGNETICALLY ENCODED DEBIT, PREPAID AND LOYALTY SCHEME CARDS; COMPUTER AND ELECTRONIC GAMES SOFTWARE; SLOT MACHINES; COIN-OPERATED GAMBLING AND BETTING MACHINES (U.S. CLS. 21, 23, 26, 36 AND 38).

CLASS 36—INSURANCE AND FINANCIAL

FOR DEBIT AND CREDIT CARD SERVICES RELATING TO BETTING (U.S. CLS. 100, 101 AND 102).

CLASS 38—COMMUNICATION

FOR PROVIDING MULTIPLE USE ACCESS TO THE INTERNET FOR TV AND RADIO SPORTS COMMENTARY (U.S. CLS. 100, 101 AND 104).

CLASS 41—EDUCATION AND ENTERTAINMENT

FOR CONDUCTING LOTTERIES; PROVIDING CASINO AND GAMING SERVICES BY MEANS OF A WEBSITE AND A GLOBAL COMPUTER NETWORK; PROVIDING ON-LINE ENTERTAINMENT INFORMATION ABOUT CASINOS, GAMBLING AND ONLINE GENERAL ENTERTAINMENT NEWS ABOUT THE GAMING INDUSTRY; ENTERTAINMENT SERVICES IN THE NATURE OF ON-LINE GAMING AND GAMBLING; PROVIDING ON-LINE COMPUTER GAMES; PROVIDING INFORMATION REGARDING ON-LINE GAMES; PROVIDING INFORMATION ON-LINE FROM A COMPUTER DATABASE OR ELECTRONIC NETWORK, INCLUDING THE INTERNET, RELATING TO ENTERTAINMENT AND SPORTING EVENTS; BETTING SERVICES, ON-LINE BETTING SERVICES, ELECTRONIC BETTING AND TELEPHONE BETTING SERVICES, BETTING CONSULTATION SERVICES; NON-DOWNLOADABLE ELECTRONIC PUBLICATIONS, NAMELY, BOOKS, NEWSPAPERS, NEWSLETTERS, MAGAZINES, BROCHURES, BOOKLETS, PAMPHLETS AND MANUALS FEATURING GAMING, GAMBLING AND BETTING (U.S. CLS. 100, 101 AND 107).

KHANH LE, EXAMINING ATTORNEY

SN 85-083,664. JMEA CORPORATION, ROCKVILLE, MD.
FILED 7-13-2010.

ARISTOTLE

THE MARK CONSISTS OF STANDARD CHARACTERS WITHOUT CLAIM TO ANY PARTICULAR FONT, STYLE, SIZE, OR COLOR.

CLASS 5—PHARMACEUTICALS

FOR SURGICAL IMPLANTS CONTAINING BIOLOGICAL MATERIALS (U.S. CLS. 6, 18, 44, 46, 51 AND 52).

CLASS 10—MEDICAL APPARATUS

FOR MEDICAL APPARATUS AND INSTRUMENTS FOR USE IN ORTHOPEDIC SURGERY; SURGICAL APPARATUS AND INSTRUMENTS FOR USE IN ORTHOPEDIC SURGERY; SURGICAL DEVICES AND INSTRUMENTS; SURGICAL IMPLANTS COMPRISING ARTIFICIAL MATERIAL AND ASSOCIATED SURGICAL INSTRUMENT SETS; MEDICAL, SURGICAL AND ORTHOPEDIC IMPLANTS MADE OF ARTIFICIAL MATERIALS; IMPLANTS CONSISTING OF ARTIFICIAL MATERIALS; SURGICAL INSTRUMENTS AND APPARATUS; MEDICAL PRODUCT AND INSTRUMENT TRAYS FOR SURGERY (U.S. CLS. 26, 39 AND 44).

MICHELE SWAIN, EXAMINING ATTORNEY

SN 85-088,225. ASSOCIATED MATERIALS, LLC, CUYAHOGA FALLS, OH. FILED 7-20-2010.

FORECASTER

THE MARK CONSISTS OF STANDARD CHARACTERS WITHOUT CLAIM TO ANY PARTICULAR FONT, STYLE, SIZE, OR COLOR.

CLASS 6—METAL GOODS

FOR METAL WINDOWS, METAL STORM DOORS (U.S. CLS. 2, 12, 13, 14, 23, 25 AND 50).

CLASS 19—NON-METALLIC BUILDING MATERIALS

FOR NON-METAL WINDOWS, NON-METAL STORM DOORS (U.S. CLS. 1, 12, 33 AND 50).
COLLEEN KEARNEY, EXAMINING ATTORNEY

SN 85-088,379. ACCRUENT, LLC, FORMERLY ACCRUENT, INC., SANTA MONICA, CA. FILED 7-20-2010.

CLASS 42—SCIENTIFIC AND COMPUTER SERVICES

FOR DATABASE DEVELOPMENT SERVICES; PROVIDING FOR OTHERS TEMPORARY USE OF ON-LINE NON-DOWNLOADABLE SOFTWARE FOR DATABASE MANAGEMENT; APPLICATION SERVICE PROVIDER FEATURING SOFTWARE IN THE FIELD OF CREATING, ADMINISTERING, ABSTRACTING, AND MANAGING LEASES AND BUSINESS CONTRACTS AND FOR THE PURPOSES OF STREAMLINING AND AUTOMATING THE CONTRACT MANAGEMENT PROCESS, NAMELY, FOR AUTOMATED BENCHMARKING, FOR TRACKING CRITICAL DATES, SCHEDULED COSTS AND ON-GOING TERMS FOR CONTRACT MANAGEMENT, FOR ABSTRACTING CRITICAL TERMS AND DATES FROM CONTRACTS, FOR DOCUMENT AND WORKFLOW MANAGEMENT, FOR PRESENTING REPORTS AND SUMMARIES OF CONTRACT INFORMATION IN SIMPLIFIED FORMATS, FOR PROVIDING ACCESS TO INFORMATION AND ANALYSIS ON BUSINESS TOPICS, NAMELY, ON REAL ESTATE, EQUIPMENT LEASING, WARRANTIES, FINANCE, TAX AND ACCOUNTING, FOR EXPORTING INFORMATION TO ACCOUNTING AND FINANCIAL SYSTEMS, AND TO ENABLE ERP INTEGRATION (U.S. CLS. 100 AND 101).
FIRST USE 11-6-2001; IN COMMERCE 11-6-2001.
STEVEN JACKSON, EXAMINING ATTORNEY

SN 85-093,812. SALESFORCE.COM, INC., SAN FRANCISCO, CA. FILED 7-27-2010.

accruent

CHATTER

THE MARK CONSISTS OF STANDARD CHARACTERS WITHOUT CLAIM TO ANY PARTICULAR FONT, STYLE, SIZE, OR COLOR.

OWNER OF U.S. REG. NO. 3,487,960.

CLASS 35—ADVERTISING AND BUSINESS

FOR BUSINESS AND BUSINESS KNOWLEDGE MANAGEMENT SERVICES; OPERATING ON-LINE MARKETPLACE FOR BUYING AND SELLING, SHARING, AND OFFERING FOR FREE COMPUTER SOFTWARE AND ON-DEMAND APPLICATIONS OF OTHERS (U.S. CLS. 100, 101 AND 102).
FIRST USE 11-18-2009; IN COMMERCE 11-18-2009.

OWNER OF U.S. REG. NO. 2,788,076.
THE MARK CONSISTS OF THE WORDING "ACCRUENT" IN STYLIZED FONT

CLASS 9—ELECTRICAL AND SCIENTIFIC APPARATUS

FOR COMPUTER SOFTWARE FOR CREATING, ADMINISTERING, ABSTRACTING, AND MANAGING LEASES AND BUSINESS CONTRACTS AND FOR THE PURPOSES OF STREAMLINING AND AUTOMATING THE CONTRACT MANAGEMENT PROCESS, NAMELY, FOR AUTOMATED BENCHMARKING, FOR TRACKING CRITICAL DATES, SCHEDULED COSTS AND ON-GOING TERMS FOR CONTRACT MANAGEMENT, FOR ABSTRACTING CRITICAL TERMS AND DATES FROM CONTRACTS, FOR DOCUMENT AND WORKFLOW MANAGEMENT, FOR PRESENTING REPORTS AND SUMMARIES OF CONTRACT INFORMATION IN SIMPLIFIED FORMATS, FOR PROVIDING ACCESS TO INFORMATION AND ANALYSIS ON BUSINESS TOPICS, NAMELY, ON REAL ESTATE, EQUIPMENT LEASING, WARRANTIES, FINANCE, TAX AND ACCOUNTING, FOR EXPORTING INFORMATION TO ACCOUNTING AND FINANCIAL SYSTEMS, AND TO ENABLE ERP INTEGRATION (U.S. CLS. 21, 23, 26, 36 AND 38).
FIRST USE 11-6-2001; IN COMMERCE 11-6-2001.

CLASS 42—SCIENTIFIC AND COMPUTER SERVICES

FOR PROVIDING TEMPORARY USE OF ON-LINE NON-DOWNLOADABLE SOFTWARE TO FACILITATE COMMUNICATING AMONG PEER PROFESSIONALS IN THE ADVERTISING, MARKETING AND BUSINESS SERVICES FIELDS AND TO STORE, MANAGE, TRACK, ANALYZE, AND REPORT DATA ALL RELATING TO BUSINESS AND KNOWLEDGE MANAGEMENT SERVICES; PROVIDING TEMPORARY USE OF ON-LINE NON-DOWNLOADABLE COMPUTER SOFTWARE APPLICATION DEVELOPMENT TOOLS FOR USE IN DEVELOPING, ANALYZING, CODING, CHECKING, AND CONTROLLING OTHER COMPUTER SOFTWARE AND CUSTOMIZING COMPUTER APPLICATION USER INTERFACES; ONLINE HOSTED COMPUTER SERVICES, NAMELY, DESIGNING, DEVELOPING, AND MAINTAINING COMPUTER SOFTWARE APPLICATIONS FOR OTHERS AND CONSULTING SERVICES RELATED THERETO (U.S. CLS. 100 AND 101).
FIRST USE 12-1-2007; IN COMMERCE 12-1-2007.
WARREN L. OLANDRIA, EXAMINING ATTORNEY

SN 85-094,491. PROFESSIONAL LANDCARE NETWORK, HERNDON, VA. FILED 7-28-2010.



OWNER OF U.S. REG. NO. 3,122,983.

NO CLAIM IS MADE TO THE EXCLUSIVE RIGHT TO USE "PROFESSIONAL LANDCARE NETWORK" AND "GREEN INDUSTRY", APART FROM THE MARK AS SHOWN.

THE STIPPLING IS FOR SHADING PURPOSES ONLY.

THE COLOR(S) BLUE, GREEN, AND WHITE IS/ARE CLAIMED AS A FEATURE OF THE MARK.

THE MARK CONSISTS OF A CIRCLE COMPRISED OF A BLUE TOP AND GREEN LOWER PORTION WITH WHITE INTERSECTING LINES; TO THE RIGHT OF THAT IS THE WORDING "PLANET UNIVERSE PROFESSIONAL LANDCARE NETWORK"; THE WORD "PLANET" IS IN BLUE, THE REMAINING WORDING IS IN GREEN; THERE IS A BLUE ARC ABOVE THIS WORDING BEGINNING IN A LIGHT SHADE OF BLUE ON THE LEFT AND GETTING DARKER AS IT MOVES TO THE RIGHT; ALL THIS IS ENCLOSED IN A BLUE RECTANGLE WITH THE WORDING "THE VOICE OF THE GREEN INDUSTRY" IN GREEN ALONG THE BOTTOM; THE BACKGROUND IS WHITE.

CLASS 35—ADVERTISING AND BUSINESS

FOR PROVIDING A SEARCHABLE ONLINE ADVERTISING WEBSITE AND INFORMATIONAL GUIDE FEATURING THE GOODS AND SERVICES OF OTHER VENDORS VIA THE INTERNET IN THE FIELD OF GREEN INDUSTRY LANDSCAPING AND LAWN CARE; PROVIDING A SEARCHABLE WEBSITE FEATURING THE GOODS AND SERVICES OF OTHER VENDORS; PROVIDING AN INTERNET WEBSITE FEATURING NEWS AND INFORMATION IN THE FIELD OF NATURAL RESOURCE MANAGEMENT RELATING TO THE ENVIRONMENT AND PUBLIC LANDS (U.S. CLS. 100, 101 AND 102).

FIRST USE 10-1-2009; IN COMMERCE 10-1-2009.

CLASS 44—MEDICAL, BEAUTY AND AGRICULTURAL SERVICES

FOR PROVIDING AN ONLINE SEARCHABLE DATABASE FEATURING INFORMATION REGARDING GREEN INDUSTRY LANDSCAPING AND LAWN CARE SERVICES (U.S. CLS. 100 AND 101).

FIRST USE 10-1-2009; IN COMMERCE 10-1-2009.

SUE LAWRENCE, EXAMINING ATTORNEY

CLASS 1—CHEMICALS

FOR CHEMICAL ADDITIVES, NAMELY, MOLYBDENUM DISULPHIDE FOR ENHANCING THE PERFORMANCE OF LUBRICATING OILS, GREASES, FLUIDS, BONDED COATINGS, PLASTIC AND METAL COMPOSITES; MOLYBDENUM DISULPHIDE FOR USE AS A FILLER IN THE MANUFACTURE OF ALLOY STEELS, TOOL AND HIGH-SPEED STEELS, STAINLESS STEELS, SUPER ALLOYS, CAST IRONS AND CAST STEELS (U.S. CLS. 1, 5, 6, 10, 26 AND 46).

FIRST USE 12-19-1949; IN COMMERCE 12-19-1949.

CLASS 4—LUBRICANTS AND FUELS

FOR ALL PURPOSE LUBRICANTS, AUTOMOTIVE LUBRICANTS, DRILLING LUBRICANTS, INDUSTRIAL AND VEHICULAR LUBRICANTS, LUBRICANTS FOR INDUSTRIAL MACHINERY, LUBRICANTS FOR HOUSEHOLD ITEMS, GRINDING FLUIDS, MARINE LUBRICANTS, PREMIUM SPECIALTY LUBRICANTS AND SOLID FILM LUBRICANTS, ALL MADE FROM MOLYBDENUM DISULFIDE (U.S. CLS. 1, 6 AND 15).

FIRST USE 12-19-1949; IN COMMERCE 12-19-1949.

MARY ROSSMAN, EXAMINING ATTORNEY

SN 85-096,674. JX HOLDINGS, INC., TOKYO, JAPAN, FILED 7-30-2010.

JX Nippon Mining & Metals

SN 85-096,108. CYPRUS AMAX MINERALS COMPANY, PHOENIX, AZ. FILED 7-29-2010.

MOLYSULFIDE

THE MARK CONSISTS OF STANDARD CHARACTERS WITHOUT CLAIM TO ANY PARTICULAR FONT, STYLE, SIZE, OR COLOR.

OWNER OF U.S. REG. NO. 676,872.

THE MARK CONSISTS OF STANDARD CHARACTERS WITHOUT CLAIM TO ANY PARTICULAR FONT, STYLE, SIZE, OR COLOR.

OWNER OF JAPAN REG. NO. 5355583, DATED 9-24-2010, EXPIRES 9-24-2020.

NO CLAIM IS MADE TO THE EXCLUSIVE RIGHT TO USE "NIPPON MINING & METALS", APART FROM THE MARK AS SHOWN.

THE ENGLISH TRANSLATION OF "NIPPON" IN THE MARK IS "JAPAN".

CLASS 1—CHEMICALS

FOR CHEMICALS FOR INDUSTRIAL PURPOSES, NAMELY, SURFACE PREPARATION AGENTS FOR METALS, RESINS, CERAMICS OR RUBBERS IN THE NATURE OF SOLVENTS; CHEMICALS FOR INDUSTRIAL PURPOSES, NAMELY, HEAT ACCUMULATION AGENTS, NAMELY, HEAT TRANSFER FLUIDS; CLEANING AGENTS FOR USE IN MANUFACTURING PROCESSES, NAMELY, CHEMICAL PREPARATION IN THE NATURE OF DEGREASING AND CLEANING SOLVENTS; CHEMICALS FOR INDUSTRIAL USE, NAMELY, CLEANING SOLVENTS; CHEMICALS FOR INDUSTRIAL USE, NAMELY, SOLVENTS FOR CLEANING MACHINES AND APPARATUS AND MACHINE PARTS; CHEMICAL PREPARATIONS FOR INDUSTRIAL PURPOSES, NAMELY, CLEANING AGENTS FOR MACHINES AND APPARATUS AND MACHINE PARTS USED IN MANUFACTURING PROCESSES IN THE NATURE OF DEGREASING AND CLEANING SOLVENTS; CARBON FOR INDUSTRIAL PURPOSES, NAMELY, CARBON MATERIALS FOR CONDENSERS OR RECHARGEABLE BATTERIES OR OIL ABSORBENT, PLATING SOLUTIONS, METAL OXIDES FOR SPUTTERING TARGETS, HIGH PURITY COPPER SULFATE; CHEMICALS FOR USE IN INDUSTRY; ADHESIVES, OTHER THAN FOR STATIONERY OR HOUSEHOLD PURPOSES; PLANT GROWTH REGULATING PREPARATIONS; FERTILIZERS; CERAMIC GLAZINGS; PRIMING PUTTY, NAMELY, OIL CEMENT; HIGHER FATTY ACIDS FOR INDUSTRIAL USE; RARE-EARTH METALS; NON-METALLIC MINERALS, NAMELY, SULPHUR, FOUNDRY SAND, KAOLIN, TALC, ROCK SALT, DIATOMACEOUS EARTH, ACID CLAY, BARITES, SALTPETER, NATURAL GRAPHITE, DOLOMITE, CRYOLITE, BENTONITE, BAUXITE, FLUORITE, MAGNESITE, ALUNITE, ROCK PHOSPHATE; PHOTOGRAPHIC SUPPLIES, NAMELY, PHOTOGRAPHIC CHEMICALS, UNEXPOSED PHOTOGRAPHIC FILM, PHOTOGRAPHIC PAPER; CHEMICAL TEST PAPER; ARTIFICIAL SWEETENERS; FLOUR AND STARCH FOR INDUSTRIAL PURPOSES, NAMELY, WHEAT FLOUR, RICE FLOUR, CORN STARCH; UNPROCESSED PLASTICS; PULP, NAMELY, PAPER PULP, GROUNDWOOD PULP, CHEMICAL PULP; ANTIMONY; SELENIUM; THALLIUM; TELLURIUM; LITHIUM; SILICON FOR SOLAR BATTERIES, CELLS AND MODULES; SILICON FOR SEMICONDUCTORS, AROMATIC HYDROCARBONS CLEANING AGENTS IN THE NATURE OF AROMATIC SOLVENTS FOR INDUSTRIAL AND COMMERCIAL USE; CHEMICAL PREPARATIONS, NAMELY, SOLVENTS FOR CLEANING MACHINES AND APPARATUS AND MACHINE PARTS (U.S. CLS. 1, 5, 6, 10, 26 AND 46).

CLASS 6—METAL GOODS

FOR BLINDS OF METAL, NAMELY, METAL EXTERIOR BLINDS; IRONS AND STEELS; NONFERROUS METALS AND THEIR ALLOYS FOR SPUTTERING TARGETS; NONFERROUS METALS AND THEIR ALLOYS; ORES OF METAL, NAMELY, ZINC ORES, ANTIMONY ORES, URANIUM ORES, GOLD ORES, SILVER ORES, CHROME IRON ORES, COBALT ORES, MERCURY ORES, TIN ORES, BISMUTH ORES, TUNGSTEN ORES, IRON ORES, COPPER ORES, THORIUM ORES, LEAD ORES, NICKEL ORES, MANGANESE ORES, MOLYBDENUM ORES, IRON PYRITES; METAL MATERIALS FOR BUILDING OR CONSTRUCTION, NAMELY, CHIMNEY SHAFTS, STAIR TREADS, GUARDRAILS, WALL LININGS, PILINGS, GRATINGS, TUNNELING MATERIALS, FENCES, SHUTTERS, WATER-PIPES, TILES, STEEL FRAMES FOR BUILDING, SHELF BOARDS, HANDRAILS, GABIONS OF STEEL WIRE, CEILING BOARDS, CEILING DECORATIONS, ELECTRIC POLES, GUTTERS, DOORS, PILLARS, WAINSCOTINGS, BEAMS, GRILLES, WIRE FENCES, FIRE RETARDING DOORS, FLOOR PAVINGS, WINDOWS, WINDOW FRAMES, MANHOLE COVERS, GATES, BARBED WIRES, FLOOR BOARDS, LOUVER DOORS, ROCKSLIDE RETENTION WIRE NETS, LATHS; PREFABRICATED BUILDING ASSEMBLY KITS OF METAL; LOADING AND UNLOADING PALLETS OF METAL; METAL TURN-TABLES FOR LOAD HANDLING, NOT BEING PARTS OF MACHINES; METAL TRAVERSERS FOR LOAD HANDLING, NOT BEING PARTS OF MACHINES; ARTIFICIAL FISH REEFS OF METAL; POULTRY CAGES OF METAL; PAINT SPRAYING BOOTHS

OF METAL; METAL MOULDS FOR FORMING CEMENT PRODUCTS; METAL KEYS FOR LOCKS; RAILWAY POINTS; ROAD SIGNS OF METAL; NON-LUMINOUS BEACONS OF METAL IN THE NATURE OF METAL POLES, METAL BUOYS; LIQUID STORAGE TANKS OF METAL; RESERVOIRS OF METAL; INDUSTRIAL WATER STORAGE TANKS OF METAL; LIQUEFIED GAS STORAGE TANKS OF METAL, NOT FOR LAND VEHICLES; GAS STORAGE TANKS OF METAL, NOT FOR LAND VEHICLES; INTERNAL FLOATING LIDS OF ALUMINUM FOR USE WITH GAS OR LIQUEFIED GAS STORAGE TANKS; MOORING BOLLARDS OF METAL; CONTAINERS OF METAL FOR TRANSPORT; ANVILS; SWAGE BLOCKS; WIRE ROPES; WIRE NETS AND GAUZES; INDUSTRIAL PACKAGING CONTAINERS OF METAL; METAL STOPPERS, NAMELY, METAL BOTTLE STOPPERS; METAL LIDS AND CAPS FOR BOTTLES, TUBING ENDS; METAL NAMEPLATES AND DOOR NAMEPLATES; METAL CHAINS FOR DOGS; METAL STEPLADDERS AND LADDERS; LETTER BOXES OF METAL; HAT-HANGING HOOKS OF METAL; MONEY BOXES OF METAL; WATER TANKS OF METAL FOR HOUSEHOLD PURPOSES; TOOL BOXES OF METAL SOLD EMPTY; TOWEL DISPENSERS OF METAL; METAL SAFES; NON-LUMINOUS AND NON-MECHANICAL UPRIGHT SIGNBOARDS OF METAL; TRANSPORTABLE GREENHOUSES OF METAL FOR HOUSEHOLD USE; METAL TOMBS AND METAL TOMB PLAQUES; FERRULES OF METAL FOR CANES AND WALKING-STICKS; CRAMPONS; DIVING PLATFORMS OF METAL; SPURS; SCULPTURES OF METAL; METAL PIGGY BANKS; NON-FERROUS METALS, NAMELY, COPPER, INDIUM, TITANIUM, TUNGSTEN, COBALT AND CADMIUM (U.S. CLS. 2, 12, 13, 14, 23, 25 AND 50).

CLASS 9—ELECTRICAL AND SCIENTIFIC APPARATUS

FOR COMPUTER PERIPHERAL DEVICES; ELECTRIC CALCULATING MACHINES; BILLING MACHINES, NAMELY, AUTOMATIC BILLING MACHINES FOR PROCESSING ACCOUNTING INFORMATION; SLIDE-RULES; SEMICONDUCTOR WAFERS, NAMELY, SILICON WAFERS, STRUCTURED SEMICONDUCTOR WAFERS; SOLAR BATTERIES; FUEL CELLS; FUEL CELL GENERATORS, NAMELY, FUEL CELLS, RECHARGERS FOR FUEL CELLS; CARD READERS, NAMELY, CARD READERS FOR CREDIT CARDS, ELECTRONIC CARD READERS, SMART CARD READERS; FILMS FOR LIQUID CRYSTAL DISPLAYS TO EXPAND VIEWING FIELD IN THE NATURE OF PLASTIC POLARIZING FILMS; BATTERIES FOR AUTOMOBILES; EAR PLUGS NOT FOR MEDICAL PURPOSES; PROCESSED GLASS, NAMELY, BULLET-PROOF GLASS, ANTI-GLARE GLASSES; METAL CUTTING APPARATUS BY ARC, GAS OR PLASMA, NAMELY, ELECTRIC ARC WELDERS, WELDING TORCHES; ELECTRIC WELDING APPARATUS, ELECTRIC ARC WELDERS, WELDING TORCHES; OZONISERS; ELECTROLYSERS; EGG-CANDLERS; CASH REGISTERS; COIN COUNTING OR SORTING MACHINES; ELECTRIC SIGN BOARDS FOR DISPLAYING TARGET FIGURES AND CURRENT OUTPUTS; PHOTO-COPYING MACHINES; HAND-OPERATED CALCULATORS, NAMELY, ABACUSES; DRAWING OR DRAFTING INSTRUMENTS AND APPARATUS, NAMELY, COMPUTER HARDWARE AND COMPUTER SOFTWARE FOR DRAWING AND DRAFTING; TIME AND DATE STAMPING MACHINES; TIME CLOCKS; PUNCHED CARD OFFICE MACHINES, NAMELY, PUNCH CLOCKS; VOTING MACHINES; POSTAGE STAMP CHECKING APPARATUS, NAMELY, POSTAGE STAMP METERS; VENDING MACHINES; GASOLINE STATION EQUIPMENT, NAMELY, FUEL PUMPS FOR SERVICE STATIONS, PETROL PUMPS FOR SERVICE STATIONS, ELECTRONIC MEASURING APPARATUS FOR MACHINES, SELF-REGULATING FUEL PUMPS; COIN-OPERATED GATES FOR CAR PARKING FACILITIES; LIFE SAVING APPARATUS AND EQUIPMENT, NAMELY, LIFE SAVING RAFTS, LIFE NETS, LIFE BELTS, LIFE JACKETS, LIFE BUOYS; FIRE EXTINGUISHERS; FIRE HYDRANTS; FIRE HOSE NOZZLES; SPRINKLER SYSTEMS FOR FIRE PROTECTION; FIRE ALARMS; GAS ALARMS, NAMELY, ALARMS FOR THE DETECTION OF INFLAMMABLE GASES; ANTI-THEFT WARNING APPARATUS, NAMELY, BURGLAR ALARMS; PROTECTIVE HELMETS; RAILWAY SIGNAL APPARATUS, LUMINOUS OR MECHANICAL, NAMELY, RAILWAY SIGNALS;

VEHICLE BREAKDOWN WARNING TRIANGLES; LUMINOUS OR MECHANICAL ROAD SIGNS; DIVING MACHINES AND APPARATUS, NAMELY, REGULATORS FOR USE IN SCUBA DIVING; ARCADE GAME CONSOLES ADAPTED FOR USE WITH AN EXTERNAL DISPLAY SCREEN OR MONITOR; ELECTRIC DOOR OPENERS; SIMULATORS FOR THE STEERING AND CONTROL OF VEHICLES; LABORATORY APPARATUS AND INSTRUMENTS, NAMELY, PIPETTES, TEST TUBES, AIR-GAS PRODUCERS, CONSTANT TEMPERATURE INCUBATORS, CONSTANT HUMIDITY INCUBATORS; PHOTOGRAPHIC INSTRUMENTS AND APPARATUS, NAMELY, CAMERAS, DIGITAL CAMERAS, VIDEO CAMERAS; CINEMATOGRAPHIC INSTRUMENTS AND APPARATUS, NAMELY, CINEMATOGRAPHIC MACHINES AND APPARATUS; OPTICAL APPARATUS AND INSTRUMENTS, NAMELY, OPTICAL CHARACTER READERS, TELESCOPES, MICROSCOPES; MEASURING OR TESTING MACHINES AND INSTRUMENTS, NAMELY, TEMPERATURE INDICATORS, WATER MATERS; DERIVED-UNIT MEASURING MACHINES AND APPARATUS, PRECISION MEASURING MACHINES AND INSTRUMENTS, NAMELY, INTERFEROMETERS, SURFACE ROUGHNESS TESTING MACHINES AND INSTRUMENTS, FLATNESS TESTING MACHINES AND INSTRUMENTS; AUTOMATIC ADJUSTING OR REGULATING MACHINES AND INSTRUMENTS, NAMELY, AUTOMATIC PRESSURE CONTROL MACHINES AND INSTRUMENTS, AUTOMATIC LIQUID-FLOW CONTROL MACHINES AND INSTRUMENTS, AUTOMATIC FLUID-COMPOSITION CONTROL MACHINES AND INSTRUMENTS, AUTOMATIC TEMPERATURE CONTROL MACHINES AND INSTRUMENTS, AUTOMATIC COMBUSTION CONTROL MACHINES AND INSTRUMENTS, AUTOMATIC VACUUM CONTROL MACHINES AND INSTRUMENTS, AUTOMATIC CALORIE CONTROL MACHINES AND INSTRUMENTS, PROGRAM CONTROL MACHINES AND INSTRUMENTS; MATERIAL TESTING MACHINES AND INSTRUMENTS FOR TESTING THE STRENGTH OF METALLIC MATERIALS, RUBBER, CONCRETE, CEMENT, TEXTILE, PLASTIC, AND LUMBER; SURVEYING MACHINES AND INSTRUMENTS, ASTRONOMETRIC MEASURING MACHINES AND INSTRUMENTS, THERMOSENSITIVE TEMPERATURE INDICATOR STRIPS, TESTERS, NAMELY, STEEL TEST PIECES FOR TESTING RUST FORMATION; POWER DISTRIBUTION OR CONTROL MACHINES AND APPARATUS, NAMELY, ELECTRIC SWITCHES, ELECTRIC RELAYS, CIRCUIT BREAKERS, POWER CONTROLLERS, CURRENT RECTIFIERS, ELECTRIC CONNECTORS, ELECTRIC CIRCUIT CLOSERS, ELECTRIC CAPACITORS, ELECTRIC RESISTORS, LOCAL SWITCHES, POWER DISTRIBUTING BOXES, PLUGBOARDS IN THE NATURE OF CIRCUIT BOARDS, FUSES, LIGHTNING ARRESTERS, ELECTRIC TRANSFORMERS, INDUCTION VOLTAGE REGULATORS, ELECTRIC REACTORS; ROTARY CONVERTERS; PHASE MODIFIERS, NAMELY, OPTICAL PHASE SHIFTER; BATTERIES; CELLS, NAMELY, DRY CELLS, FUEL CELLS, ELECTRICAL CELLS, CELLS FOR ELECTRIC VEHICLES; ELECTRIC OR MAGNETIC METERS AND TESTERS, NAMELY, ELECTRIC METERS, ELECTRIC AND MAGNETIC CONTACTS; ELECTRIC WIRES AND CABLES; ELECTRIC FLAT IRONS; ELECTRIC HAIRCURLERS; ELECTRIC BUZZERS; TELECOMMUNICATION DEVICES AND APPARATUS, NAMELY, TELEPHONE APPARATUS, WIRE COMMUNICATION MACHINES AND APPARATUS, TRANSMISSION MACHINES AND APPARATUS, BROADCASTING MACHINES AND APPARATUS, RADIO COMMUNICATION MACHINES AND APPARATUS, RADIO APPLICATION MACHINES AND APPARATUS, REMOTE CONTROL TELEMETERING MACHINES AND INSTRUMENTS, AUDIO FREQUENCY MACHINES AND APPARATUS, VIDEO FREQUENCY MACHINES AND APPARATUS, ANTENNAS, CABINETS FOR TELECOMMUNICATIONS APPARATUS, COILS, MAGNETIC TAPE ERASERS, MAGNETIC TAPE CLEANERS, MAGNETIC HEAD ERASER, MAGNETIC HEAD CLEANERS, LOUD-SPEAKERS, CONNECTORS, STAND AND RACKS FOR TELECOMMUNICATION MACHINES AND APPARATUS, DIALS, ELECTRIC CAPACITORS, FUSES, ELECTRIC RESISTORS, BLANK MAGNETIC TAPES, CHANGE-OVER SWITCHES, PLUGBOARDS, PICKUPS, BLANK VIDEO TAPES, INDICATOR LIGHTS, ELECTRICAL PHONOMOTORS, HEADPHONES, ELECTRICAL TRANSFORMERS, PROTECTORS, MICROPHONES, CLEANING APPARATUS FOR PHONOGRAPH RE-

CORDS, BLANK RECORD DISCS, SPRAYS FOR PHONOGRAPH RECORDS; ELECTRONIC MACHINES, APPARATUS AND THEIR PARTS, NAMELY, DATA PROCESSING DEVICES, COMPUTERS, COMPUTER PERIPHERAL DEVICES, MAGNETIC DATA STORAGES OR CARRIES COMPUTER SOFTWARE FOR DATABASE MANAGEMENT; MAGNETIC CORES; RESISTANCE WIRES; ELECTRODES; FIRE BOATS; FIRE ENGINES; CIGAR LIGHTERS FOR AUTOMOBILES; GLOVES FOR PROTECTION AGAINST ACCIDENTS; DUST MASKS; GAS MASKS; WELDING MASKS; FIREPROOF GARMENTS; SPECTACLES; HOME VIDEO GAME CONSOLES ADAPTED FOR USE WITH AN EXTERNAL DISPLAY SCREEN OR MONITOR; ELECTRONIC CIRCUITS AND CD-ROMS RECORDED WITH PROGRAMS FOR HAND-HELD GAMES WITH LIQUID CRYSTAL DISPLAYS; WEIGHT BELTS; INFLATABLE SWIMMING FLOATS FOR SAFETY PURPOSES; PROTECTIVE HELMETS FOR SPORTS; AIR TANKS; SWIMMING FLUTTER BOARDS IN THE NATURE OF SWIMMING FLOATS FOR SAFETY PURPOSES; REGULATORS, NAMELY, OXYGEN REGULATORS, STATIC VOLTAGE REGULATORS; PHONOGRAPH RECORDS FEATURING MUSIC; METRONOMES; ELECTRONIC CIRCUITS AND CD-ROMS RECORDED WITH AUTOMATIC PERFORMANCE PROGRAMS FOR ELECTRONIC MUSICAL INSTRUMENTS; DOWNLOADABLE MUSIC FILES VIA THE INTERNET AND WIRELESS DEVICES; EXPOSED CINEMATOGRAPHIC FILMS; EXPOSED SLIDE FILMS; SLIDE FILM MOUNTS; DOWNLOADABLE IMAGE FILES VIA THE INTERNET AND WIRELESS DEVICES FEATURING DOWNLOADABLE IMAGES FOR MOBILE PHONES; DOWNLOADABLE ELECTRONIC PUBLICATIONS IN THE NATURE OF BOOKS AND MAGAZINES IN THE FIELD OF ENERGY, OIL, EARTH RESOURCES AND INDUSTRIAL MATERIALS; AUTOMATIC VALVES; ELECTRONIC SAFES (U.S. CLS. 21, 23, 26, 36 AND 38).

DANIEL BRODY, EXAMINING ATTORNEY

SN 85-098,007. PERNOD RICARD USA, LLC, PURCHASE, NY. FILED 8-2-2010.

MALIBOOM BOOM

THE MARK CONSISTS OF STANDARD CHARACTERS WITHOUT CLAIM TO ANY PARTICULAR FONT, STYLE, SIZE, OR COLOR.

CLASS 33—WINES AND SPIRITS

FOR ALCOHOLIC BEVERAGES EXCEPT BEERS (U.S. CLS. 47 AND 49).

CLASS 38—COMMUNICATION

FOR TELECOMMUNICATIONS, NAMELY, TRANSMISSION OF VOICE, DATA, GRAPHICS, IMAGES, AUDIO AND VIDEO BY MEANS OF TELECOMMUNICATIONS NETWORKS, WIRELESS COMMUNICATION NETWORKS, AND THE INTERNET; TELECOMMUNICATIONS SERVICES, NAMELY, BROADCASTING PROGRAMS ON A GLOBAL COMPUTER NETWORK; ELECTRONIC TRANSMISSION OF VOICE, MUSIC, DATA, MULTIMEDIA PROGRAMMING, AND MESSAGES ON COMPUTER TERMINALS ON GLOBAL COMPUTER NETWORKS; WEBCASTING AUDIO/VISUAL PROGRAMMING VIA A GLOBAL COMPUTER NETWORK; PROVIDING ONLINE CHAT ROOMS AND BULLETIN BOARDS FOR THE TRANSMISSION OF MESSAGES AMONG COMPUTER USERS CONCERNING ALCOHOL, MUSIC, ART, DESIGN, CULTURE, DRAMA, ACTION, HOBBIES, CURRENT EVENTS, COMEDY, AND ENTERTAINMENT; PROVIDING ONLINE TRANSMISSION OF MESSAGES AMONG COMPUTER USERS CONCERNING ALCOHOL, MUSIC, ART, DESIGN, CULTURE, DRAMA, ACTION, HOBBIES, CURRENT EVENTS, COMEDY, AND ENTERTAINMENT; AND TEXT AND NUMERIC WIRELESS DIGITAL MESSAGING SERVICES TO MOBILE COMMUNICATIONS DEVICES (U.S. CLS. 100, 101 AND 104).

SN 85-098,053. PERNOD RICARD USA, LLC, PURCHASE, NY. FILED 8-2-2010.



OWNER OF U.S. REG. NOS. 1,374,134, 3,816,881 AND OTHERS.

NO CLAIM IS MADE TO THE EXCLUSIVE RIGHT TO USE "RADIO" AND ".COM", APART FROM THE MARK AS SHOWN.

THE COLOR(S) BROWN, ORANGE, AND PURPLE IS/ARE CLAIMED AS A FEATURE OF THE MARK.

THE MARK CONSISTS OF ORANGE WORD "RADIO" IN WHICH THE LETTER "A" IS REPRESENTED BY AN ANTENNA, POSITIONED TO THE LEFT OF TWO BROWN AND WHITE COCONUT TREES IN FRONT OF AN ORANGE SUN, ALL OF WHICH IS ABOVE THE PURPLE WORDING "MALIBOOM BOOM .COM". THE COLOR WHITE REPRESENTS A TRANSPARENT AREA AND IS NOT PART OF THE MARK.

CLASS 41—EDUCATION AND ENTERTAINMENT

FOR EDUCATIONAL SERVICES AND PROVIDING OF TRAINING AND ENTERTAINMENT, NAMELY, ARRANGING AND CONDUCTING CLASSES, SEMINARS, CONFERENCES AND WORKSHOPS IN THE FIELD OF ALCOHOL, ALCOHOL AWARENESS AND MODERATION, AND ALCOHOL SALES, DISTRIBUTION AND MARKETING, AND DISTRIBUTION OF COURSE MATERIALS IN CONNECTION THEREWITH; ORGANIZING SPORTING AND CULTURAL ACTIVITIES, NAMELY, ORGANIZING COMMUNITY SPORTING AND CULTURAL EVENTS; ENTERTAINMENT SERVICES, NAMELY, PROVIDING INFORMATION IN THE FIELDS OF RECREATIONAL LEISURE ACTIVITIES, MUSIC, CULTURE, FASHION SHOWS AND MOVIES; ENTERTAINMENT IN THE NATURE OF ONGOING MULTIMEDIA INTERNET PROGRAMS AND ONGOING SERIES IN THE FIELDS OF MUSIC, ART, DESIGN, CULTURE, FASHION, DRAMA, ACTION, HOBBIES, CURRENT EVENTS, COMEDY AND LEISURE BROADCAST ON GLOBAL COMPUTER NETWORKS; PROVIDING NON-DOWNLOADABLE ONLINE MAGAZINES AND NEWSLETTERS IN THE FIELDS OF BEVERAGES, MUSIC, ART, DESIGN, CULTURE, FASHION, DRAMA, ACTION, HOBBIES, CURRENT EVENTS, COMEDY, AND ENTERTAINMENT; ENTERTAINMENT SERVICES IN THE NATURE OF A FAN CLUB; ENTERTAINMENT SERVICES, NAMELY, PROVIDING ONLINE COMPUTER GAMES; ARRANGING AND CONDUCTING ENTERTAINMENT EXHIBITIONS IN THE FIELDS OF ART, MUSIC, CULTURE AND MOVIES; AND ARRANGING OF CONTESTS (U.S. CLS. 100, 101 AND 107).

CAROLINE WOOD, EXAMINING ATTORNEY

CLASS 33—WINES AND SPIRITS

FOR ALCOHOLIC BEVERAGES EXCEPT BEERS (U.S. CLS. 47 AND 49).

CLASS 38—COMMUNICATION

FOR TELECOMMUNICATIONS, NAMELY, TRANSMISSION OF VOICE, DATA, GRAPHICS, IMAGES, AUDIO AND VIDEO BY MEANS OF TELECOMMUNICATIONS NETWORKS, WIRELESS COMMUNICATION NETWORKS, AND THE INTERNET; TELECOMMUNICATIONS SERVICES, NAMELY, BROADCASTING PROGRAMS ON A GLOBAL COMPUTER NETWORK; ELECTRONIC TRANSMISSION OF VOICE, MUSIC, DATA, MULTIMEDIA PROGRAMMING, AND MESSAGES ON COMPUTER TERMINALS ON GLOBAL COMPUTER NETWORKS; WEBCASTING AUDIO/VISUAL PROGRAMMING VIA A GLOBAL COMPUTER NETWORK; PROVIDING ONLINE CHAT ROOMS AND BULLETIN BOARDS FOR THE TRANSMISSION OF MESSAGES AMONG COMPUTER USERS CONCERNING ALCOHOL, MUSIC, ART, DESIGN, CULTURE, DRAMA, ACTION, HOBBIES, CURRENT EVENTS, COMEDY, AND ENTERTAINMENT; PROVIDING ONLINE TRANSMISSION OF MESSAGES AMONG COMPUTER USERS CONCERNING ALCOHOL, MUSIC, ART, DESIGN, CULTURE, DRAMA, ACTION, HOBBIES, CURRENT EVENTS, COMEDY, AND ENTERTAINMENT; AND TEXT AND NUMERIC WIRELESS DIGITAL MESSAGING SERVICES TO MOBILE COMMUNICATIONS DEVICES (U.S. CLS. 100, 101 AND 104).

CLASS 41—EDUCATION AND ENTERTAINMENT

FOR EDUCATIONAL SERVICES AND PROVIDING OF TRAINING AND ENTERTAINMENT, NAMELY, ARRANGING AND CONDUCTING CLASSES, SEMINARS, CONFERENCES AND WORKSHOPS IN THE FIELD OF ALCOHOL, ALCOHOL AWARENESS AND MODERATION, AND ALCOHOL SALES, DISTRIBUTION AND MARKETING, AND DISTRIBUTION OF COURSE MATERIALS IN CONNECTION THEREWITH; ORGANIZING SPORTING AND CULTURAL ACTIVITIES, NAMELY, ORGANIZING COMMUNITY SPORTING AND CULTURAL EVENTS; ENTERTAINMENT SERVICES, NAMELY, PROVIDING INFORMATION IN THE FIELDS OF RECREATIONAL LEISURE ACTIVITIES, MUSIC, CULTURE, FASHION SHOWS AND MOVIES; ENTERTAINMENT IN THE NATURE OF ONGOING MULTIMEDIA INTERNET PROGRAMS AND ONGOING SERIES IN THE FIELDS OF MUSIC, ART, DESIGN, CULTURE, FASHION, DRAMA, ACTION, HOBBIES, CURRENT EVENTS, COMEDY AND LEISURE BROADCAST ON GLOBAL COMPUTER NETWORKS; PROVIDING NON-DOWNLOADABLE ONLINE MAGAZINES AND NEWSLETTERS IN THE FIELDS OF BEVERAGES, MUSIC, ART, DESIGN, CULTURE, FASHION, DRAMA, ACTION, HOBBIES, CURRENT EVENTS, COMEDY, AND ENTERTAINMENT; ENTERTAINMENT SERVICES IN THE NATURE OF A FAN CLUB; ENTERTAINMENT SERVICES, NAMELY, PROVIDING ONLINE COMPUTER GAMES; ARRANGING AND CONDUCTING ENTERTAINMENT EXHIBITIONS IN THE FIELDS OF ART, MUSIC, CULTURE AND MOVIES; AND ARRANGING OF CONTESTS (U.S. CLS. 100, 101 AND 107).

CAROLINE WOOD, EXAMINING ATTORNEY

SN 85-098,820, FAMILY DOLLAR STORES OF MICHIGAN, INC., MATTHEWS, NC. FILED 8-3-2010.

MIX & CO.

THE MARK CONSISTS OF STANDARD CHARACTERS WITHOUT CLAIM TO ANY PARTICULAR FONT, STYLE, SIZE, OR COLOR.

NO CLAIM IS MADE TO THE EXCLUSIVE RIGHT TO USE "CO.", APART FROM THE MARK AS SHOWN.

CLASS 10—MEDICAL APPARATUS

FOR SURGICAL SCRUB SUITS (U.S. CLS. 26, 39 AND 44).

CLASS 14—JEWELRY

FOR JEWELRY, NAMELY, EARRINGS, BRACELETS, NECKLACES, PINS BEING JEWELRY, BROACHES, BODY JEWELRY, AND WATCHES (U.S. CLS. 2, 27, 28 AND 50).

CLASS 18—LEATHER GOODS

FOR BEACH BAGS, WALLETS, LUGGAGE, WAIST PACKS, KEY CASES, TOTE BAGS, PURSES, AND HANDBAGS (U.S. CLS. 1, 2, 3, 22 AND 41).

CLASS 21—HOUSEWARES AND GLASS

FOR DUSTERS (U.S. CLS. 2, 13, 23, 29, 30, 33, 40 AND 50).

CLASS 25—CLOTHING

FOR SLEEPWEAR, NAMELY, PAJAMAS, NIGHTGOWNS, SLEEP SHIRTS, SLEEP SETS, ROBES, CHEMISES, SLEEP PANTS, SLEEP SHORTS, CAMISOLES, UNDERWEAR, NAMELY, BRAS, PANTIES, SLIPS, SHAPWEAR, NAMELY, CONTROL BRIEF, CONTROL CAMISOLE, AND THIGH SLIMMER; THERMAL UNDERWEAR; FOOTWEAR, NAMELY, SHOES, SANDALS, SLIPPERS, SOCKS AND HOSIERY; CLOTHING, NAMELY, SWEATERS, TOPS, BOTTOMS, JEANS, PANTS, SHIRTS, SKIRTS, SHORTS, DRESSES, CAPRIS, BELTS, T-SHIRTS, BLOUSES, AND JUMPERS; OUTERWEAR, NAMELY, JACKETS, COATS AND GLOVES; ACTIVEWEAR, NAMELY, ATHLETIC SHIRTS, SHORTS AND PANTS; HEADGEAR, NAMELY, HATS, VISORS AND CAPS; SCRUBS NOT FOR MEDICAL PURPOSES; SCARVES; HEADBANDS; HEADSCARVES (U.S. CLS. 22 AND 39).

CLASS 26—FANCY GOODS

FOR HAIR ACCESSORIES, NAMELY, HAIR CLIPS, HAIR PINS, ELASTIC HAIR BANDS, HAIR TWISTERS (U.S. CLS. 37, 39, 40, 42 AND 50).

SANJEEV VOHRA, EXAMINING ATTORNEY

SN 85-099,193, ZIEBART INTERNATIONAL CORPORATION, TROY, MI. FILED 8-3-2010.



OWNER OF U.S. REG. NOS. 872,779, 1,125,370 AND OTHERS.

NO CLAIM IS MADE TO THE EXCLUSIVE RIGHT TO USE "EST. 1959", APART FROM THE MARK AS SHOWN.

THE MARK CONSISTS OF A SHIELD WITH "ZIEBART" WRITTEN DIAGONALLY ACROSS IT AND A HELMET PROFILE AT THE TOP OF THE SHIELD.

CLASS 1—CHEMICALS

FOR DEGREASING FLUID IN THE NATURE OF DEGREASING SOLVENTS; FABRIC PROTECTANT SPRAY COATING FOR VEHICLE UPHOLSTERY, CARPETS AND TRIM; SEALANTS FOR VEHICLE EXTERIORS (U.S. CLS. 1, 5, 6, 10, 26 AND 46).

FIRST USE 6-30-2010; IN COMMERCE 6-30-2010.

CLASS 2—PAINTS

FOR PAINTS; COATINGS IN THE NATURE OF AUTOMOBILE DETAILING AND FINISHING; ANTI-CORROSIVE COATINGS; RUST PREVENTATIVES IN THE NATURE OF A COATING; ANTI-RUST COMPOUNDS; ANTI-RUST SPRAY; VINYL TOP DRESSING IN THE NATURE OF CLEAR COATING PROTECTANTS FOR VEHICLES; PROTECTIVE COATINGS IN THE NATURE OF PIGMENTED AND NON-PIGMENTED PAINTS; PROTECTIVE COATINGS FOR USE ON VEHICLES TO PREVENT ROAD ABRASIONS, CORROSION AND FOR SOUND-DEADENING; SOUNDPROOFING COATINGS FOR USE ON VEHICLES; RUSTPROOFING MATERIALS IN THE NATURE OF A COATING; PRESERVATIVES AGAINST RUST IN THE NATURE OF A COATING; PIGMENTS; PROTECTIVE COATINGS FOR PLASTIC SURFACES; LEATHER AND VINYL SEALERS IN THE NATURE OF PERMANENT COLOR REFINISH FOR LEATHER AND VINYL; PAINT SEALANT FOR EXTERIOR SURFACES OF VEHICLES (U.S. CLS. 6, 11 AND 16).

FIRST USE 6-30-2010; IN COMMERCE 6-30-2010.

CLASS 3—COSMETICS AND CLEANING PREPARATIONS

FOR UPHOLSTERY CLEANERS; LEATHER AND VINYL CLEANING PREPARATIONS; SOAPS; SPOT REMOVER; CLEANING AND POLISHING PREPARATIONS; STAIN REMOVERS; POLISHING PREPARATIONS; POLISHING WAXES; POLISHING, SCOURING AND ABRASIVE PREPARATIONS; WAXES FOR CLEANING AND PRESERVING LEATHER; EXFOLIATING AGENTS FOR STRIPPING PAINTS; RUST REMOVING PREPARATIONS (U.S. CLS. 1, 4, 6, 50, 51 AND 52).

FIRST USE 6-30-2010; IN COMMERCE 6-30-2010.

CLASS 37—CONSTRUCTION AND REPAIR

FOR PAINTING OF VEHICLES; PRESERVATION IN THE NATURE OF ANTI-RUST TREATMENTS AND PROTECTIVE COATINGS AND SEALANTS; RECONDITIONING SERVICES IN THE NATURE OF POLISHING, WASHING, CLEANING, DETAILING AND CONDITIONING FOR VEHICLES; RUSTPROOFING SERVICES; VEHICLE REPAIR SERVICES; APPLICATION OF PROTECTIVE COATING FOR OUTSIDE SURFACES OF AUTOMOBILES; APPLICATION OF PROTECTIVE COATING FOR THE INSIDE OF AUTOMOBILES; AUTOMOTIVE PAINT REPAIR; INTERIOR VACUUMING OF VEHICLES; AUTOMOTIVE INTERIOR DETAILING; INTERIOR CLEANING OF SEATS, CARPETS, HEADLINERS, DOOR PANELS, DASHBOARDS, AND DECKS OF VEHICLES; EXTERIOR CLEANING AND POLISHING OF VEHICLES; ENGINE CLEANING; SOUNDPROOFING OF VEHICLES; APPLICATION OF PROTECTIVE COATINGS TO PREVENT ROAD ABRASIONS; APPLICATION OF PROTECTIVE COATINGS TO INTERIOR SURFACES; APPLICATION OF GRAPHICS TO VEHICLE BODY; AFTER MARKET INSTALLATION ON VEHICLES OF SPRAY-ON OR MOLDED TRUCK BED LINERS, SUNROOFS, SPLASH GUARDS, PROTECTIVE MOLDINGS, RUNNING BOARDS, TRUCK PASS-THROUGH WINDOWS, BUG DEFLECTORS, VAN RACKS, DECK/ROOF RACKS, CAB EXTENDERS, SPLASH GUARDS, GRILL GUARDS, TRAILER HITCHES, LUGGAGE RACKS, ELECTRIC DOOR LOCKS, POWER WINDOWS, BURGLAR ALARMS, AND WINDOW TINTING; INSTALLATION OF REMOTE CAR STARTERS; REPAIR AND REPLACEMENT OF AUTOMOTIVE GLASS; SCRATCH AND DENT REPAIR; CARPET RESTORATION; FABRIC PROTECTION SERVICES IN THE NATURE OF CLEANING AND APPLYING FABRIC PROTECTANT COATINGS; APPLICATION OF DISINFECTANT FOR VEHICLES; INSTALLATION ON VEHICLES OF COMPACT DISC PLAYERS AND OTHER AUDIO EQUIPMENT (U.S. CLS. 100, 103 AND 106).

FIRST USE 6-30-2010; IN COMMERCE 6-30-2010.
ANN E. SAPPENFIELD, EXAMINING ATTORNEY

SN 85-099,696. DOUBLE FINE PRODUCTIONS, INC., SAN FRANCISCO, CA. FILED 8-4-2010.

COSTUME QUEST

THE MARK CONSISTS OF STANDARD CHARACTERS WITHOUT CLAIM TO ANY PARTICULAR FONT, STYLE, SIZE, OR COLOR.

NO CLAIM IS MADE TO THE EXCLUSIVE RIGHT TO USE "COSTUME", APART FROM THE MARK AS SHOWN.

CLASS 9—ELECTRICAL AND SCIENTIFIC APPARATUS

FOR COMPUTER AND VIDEO GAME SOFTWARE; DOWNLOADABLE COMPUTER AND VIDEO GAME PROGRAMS (U.S. CLS. 21, 23, 26, 36 AND 38).

CLASS 28—TOYS AND SPORTING GOODS

FOR TOYS, GAMES AND PLAYTHINGS, NAMELY, PLAYSETS CONSISTING OF ANY OF TOY ACTION FIGURES, DOLLS, ANIMALS, TOY BUILDINGS WITH COORDINATED BACKGROUND PANORAMAS FEATURING HALLOWEEN MOTIFS AND ACCESSORIES THEREFOR; PLAYSETS CONSISTING OF HALLOWEEN TOY CHARACTERS, IN THE NATURE OF COLLECTIBLE FIGURES, DOLLS, ANIMALS, TOY BUILDINGS WITH BACKGROUND PANORAMAS FEATURING HALLOWEEN MOTIFS AND ACCESSORIES THEREFOR; SOFT SCULPTURE TOYS CONSISTING OF TOY ACTION FIGURES, DOLLS, AND ANIMALS, TOY BUILDINGS; ANIMATED SOFT SCULPTURE TOYS CONSISTING OF TOY ACTION FIGURES, DOLLS, TOY BUILDINGS; ANIMATED PLASTIC TOYS CONSISTING OF TOY ACTION FIGURES, DOLLS, TOY BUILDINGS; TOY JEWELRY AND TOY JEWELRY BOXES; SHAKING TOY FIGURES; POP-UP TOYS, NAMELY, TOY FIGURES, DOLLS, AND ANIMALS; HALLOWEEN TOY CHARACTERS IN THE NATURE OF COLLECTIBLE TOY PUPPET FIGURES; HALLOWEEN TOY CHARACTERS IN THE NATURE OF PUPPET SKELETONS, GHOSTS, GOBBLINS, AND GOULDS; HALLOWEEN TOY BATONS WITH AND WITHOUT SOUND ELECTRONICS; SLIDE PUZZLES, JIGSAW PUZZLES AND MANIPULATIVE PUZZLES; HALLOWEEN TOY SKULLS WITH AND WITHOUT ELECTRONICS; HALLOWEEN TOY PAILS MADE OF PLASTIC; YO-YOS; HALLOWEEN COSTUME ACCESSORIES IN THE NATURE OF TOY NOVELTY ITEMS, NAMELY, FAKE BROOMS, BOOT COVERS, SWORDS, EYE PATCHES, WEAPONS, PLASTIC CIGARETTE HOLDERS, PITCHFORKS, HEADPIECES, SICKLES, FANS, GLASSES, WINGS, DEVIL HORNS, TAILS, BALL AND CHAINS, GENIE LAMPS, SCYTHES, BADGES, PISTOLS, ANTENNAS, HANDCUFFS, HANDBAGS, FANGS, INFLATABLE FIRE EXTINGUISHERS, CROSSES, SAIS, SUNGLASSES, PIRATE HOOKS, GUNS, WANDS, AXES, HOLSTERS, CUTLASSES (U.S. CLS. 22, 23, 38 AND 50).

CLASS 41—EDUCATION AND ENTERTAINMENT

FOR ENTERTAINMENT SERVICES, NAMELY PROVIDING ON-LINE COMPUTER AND VIDEO GAMES (U.S. CLS. 100, 101 AND 107).

KATHRYN COWARD, EXAMINING ATTORNEY

SN 85-100,271. DISCOVERY COMMUNICATIONS, LLC,
SILVER SPRING, MD. FILED 8-4-2010.

SN 85-100,327. DISCOVERY COMMUNICATIONS, LLC,
SILVER SPRING, MD. FILED 8-4-2010.



NO CLAIM IS MADE TO THE EXCLUSIVE RIGHT TO USE "VBOOK", APART FROM THE MARK AS SHOWN.

THE COLOR(S) BLUE, GREEN, WHITE, BLACK AND GRAY IS/ARE CLAIMED AS A FEATURE OF THE MARK.

THE MARK CONSISTS OF THE STYLIZED BLACK LETTER "D", WITH A GLOBE DESIGN FEATURING THE COLORS BLUE, GREEN, WHITE AND GRAY INDICATING LAND, WATER AND CLOUDS SUPERIMPOSED OVER THE BOTTOM LEFT CORNER OF THE LETTER "D"; A BLUE LETTER "V" CONNECTED TO THE WORD "BOOK" IN BLACK.

CLASS 9—ELECTRICAL AND SCIENTIFIC APPARATUS

FOR DOWNLOADABLE MP3 FILES, MP3 RECORDINGS, VIDEO RECORDINGS, VIDEO BOOKS, ELECTRONIC BOOKS, WEBCASTS, WEBINARS AND PODCASTS, ALL FEATURING KINDERGARTEN THROUGH 12TH GRADE (K-12) EDUCATION AND UNIVERSITY-LEVEL SUBJECTS AND TOPICS OF GENERAL INTEREST, NAMELY, BUSINESS, ENGINEERING, FINE ARTS, HEALTH, NUTRITION, MEDICINE, HISTORY, HUMANITIES, LANGUAGE, LITERATURE, MATHEMATICS, SCIENCE, SOCIAL SCIENCE, SOCIETY AND CULTURE, AND TEACHING AND EDUCATIONAL AIDS ASSOCIATED THEREWITH; DOWNLOADABLE EDUCATIONAL MATERIALS, NAMELY, LECTURES, PRESENTATIONS AND COURSE MATERIALS ALL FEATURING KINDERGARTEN THROUGH 12TH GRADE (K-12) EDUCATION AND UNIVERSITY-LEVEL SUBJECTS AND TOPICS OF GENERAL INTEREST, NAMELY, IN THE FIELD OF BUSINESS, ENGINEERING, FINE ARTS, HEALTH, NUTRITION, MEDICINE, HISTORY, HUMANITIES, LANGUAGE, LITERATURE, MATHEMATICS, SCIENCE, SOCIAL SCIENCE, SOCIETY AND CULTURE (U.S. CLS. 21, 23, 26, 36 AND 38).

CLASS 41—EDUCATION AND ENTERTAINMENT

FOR EDUCATIONAL AND ENTERTAINMENT SERVICES, NAMELY, PROVIDING NONDOWNLOADABLE PRERECORDED AUDIO AND AUDIOVISUAL CONTENT, INFORMATION AND COMMENTARY RELATING TO ENTERTAINMENT AND EDUCATION IN THE NATURE OF CLASSES, LECTURES, PODCASTS AND ELECTRONIC PUBLICATIONS IN THE NATURE OF BOOKS, E-BOOKS, MAGAZINES, E-ZINES, VIDEO BOOKS, NEWSLETTERS, NEWSFEEDS, JOURNALS, AND MANUALS, ALL FEATURING KINDERGARTEN THROUGH 12TH GRADE (K-12) EDUCATION AND UNIVERSITY-LEVEL SUBJECTS AND TOPICS OF GENERAL INTEREST, NAMELY, BUSINESS, ENGINEERING, FINE ARTS, HEALTH, NUTRITION, MEDICINE, HISTORY, HUMANITIES, LANGUAGE, LITERATURE, MATHEMATICS, SCIENCE, SOCIAL SCIENCE, SOCIETY AND CULTURE, AND TEACHING AND EDUCATIONAL AIDS ASSOCIATED THEREWITH (U.S. CLS. 100, 101 AND 107).

BARBARA RUTLAND, EXAMINING ATTORNEY

NO CLAIM IS MADE TO THE EXCLUSIVE RIGHT TO USE "VBOOK", APART FROM THE MARK AS SHOWN.

THE COLOR(S) BLUE, GREEN, WHITE, BLACK AND GRAY IS/ARE CLAIMED AS A FEATURE OF THE MARK.

THE MARK CONSISTS OF THE STYLIZED BLUE WORD "MY", WITH A GLOBE DESIGN FEATURING THE COLORS BLUE, GREEN, WHITE AND GRAY INDICATING LAND, WATER AND CLOUDS SUPERIMPOSED OVER THE BOTTOM LEFT CORNER OF THE LETTER "D"; THE WORD "DISCOVERY" IN BLACK AND A BLUE LETTER "V" CONNECTED TO THE WORD "BOOK" IN BLACK.

CLASS 9—ELECTRICAL AND SCIENTIFIC APPARATUS

FOR DOWNLOADABLE MP3 FILES, MP3 RECORDINGS, VIDEO RECORDINGS, VIDEO BOOKS, ELECTRONIC BOOKS, WEBCASTS, WEBINARS AND PODCASTS, ALL FEATURING KINDERGARTEN THROUGH 12TH GRADE (K-12) EDUCATION AND UNIVERSITY-LEVEL SUBJECTS AND TOPICS OF GENERAL INTEREST, NAMELY, BUSINESS, ENGINEERING, FINE ARTS, HEALTH, NUTRITION, MEDICINE, HISTORY, HUMANITIES, LANGUAGE, LITERATURE, MATHEMATICS, SCIENCE, SOCIAL SCIENCE, SOCIETY AND CULTURE, AND TEACHING AND EDUCATIONAL AIDS ASSOCIATED THEREWITH; DOWNLOADABLE EDUCATIONAL MATERIALS, NAMELY, LECTURES, PRESENTATIONS AND COURSE MATERIALS ALL FEATURING KINDERGARTEN THROUGH 12TH GRADE (K-12) EDUCATION AND UNIVERSITY-LEVEL SUBJECTS AND TOPICS OF GENERAL INTEREST, NAMELY, IN THE FIELD OF BUSINESS, ENGINEERING, FINE ARTS, HEALTH, NUTRITION, MEDICINE, HISTORY, HUMANITIES, LANGUAGE, LITERATURE, MATHEMATICS, SCIENCE, SOCIAL SCIENCE, SOCIETY AND CULTURE (U.S. CLS. 21, 23, 26, 36 AND 38).

CLASS 41—EDUCATION AND ENTERTAINMENT

FOR EDUCATIONAL AND ENTERTAINMENT SERVICES, NAMELY, PROVIDING NONDOWNLOADABLE PRERECORDED AUDIO AND AUDIOVISUAL CONTENT, INFORMATION AND COMMENTARY RELATING TO ENTERTAINMENT AND EDUCATION IN THE NATURE OF CLASSES, LECTURES, PODCASTS AND ELECTRONIC PUBLICATIONS IN THE NATURE OF BOOKS, E-BOOKS, MAGAZINES, E-ZINES, VIDEO BOOKS, NEWSLETTERS, NEWSFEEDS, JOURNALS, AND MANUALS, ALL FEATURING KINDERGARTEN THROUGH 12TH GRADE (K-12) EDUCATION AND UNIVERSITY-LEVEL SUBJECTS AND TOPICS OF GENERAL INTEREST, NAMELY, BUSINESS, ENGINEERING, FINE ARTS, HEALTH, NUTRITION, MEDICINE, HISTORY, HUMANITIES, LANGUAGE, LITERATURE, MATHEMATICS, SCIENCE, SOCIAL SCIENCE, SOCIETY AND CULTURE, AND TEACHING AND EDUCATIONAL AIDS ASSOCIATED THEREWITH (U.S. CLS. 100, 101 AND 107).

BARBARA RUTLAND, EXAMINING ATTORNEY

SN 85-100,670. GENERAL DNA, INC., LAS VEGAS, NV.
FILED 8-5-2010.

WE REMAIN

THE MARK CONSISTS OF STANDARD CHARACTERS WITHOUT CLAIM TO ANY PARTICULAR FONT, STYLE, SIZE, OR COLOR.

CLASS 39—TRANSPORTATION AND STORAGE

FOR STORAGE, PROTECTION OF BIOLOGICAL MATERIALS, NAMELY, STORAGE OF HUMAN HAIR, NATURAL KERATIN FIBERS, TEETH AND BONE (U.S. CLS. 100 AND 105).

CLASS 44—MEDICAL, BEAUTY AND AGRICULTURAL SERVICES

FOR RECOVERY OF HUMAN DNA MATERIAL, NAMELY, COLLECTION OF HUMAN HAIR; PRESERVATION OF BIOLOGICAL MATERIALS, NAMELY, PRESERVATION OF HUMAN HAIR, NATURAL KERATIN FIBERS, TEETH AND BONE (U.S. CLS. 100 AND 101).

MICHELLE DUBOIS, EXAMINING ATTORNEY

SN 85-101,334. GLOBUS RELIEF, SALT LAKE CITY, UT.
FILED 8-5-2010.

GLOBUS RELIEF

THE MARK CONSISTS OF STANDARD CHARACTERS WITHOUT CLAIM TO ANY PARTICULAR FONT, STYLE, SIZE, OR COLOR.

OWNER OF U.S. REG. NO. 2,846,968.

NO CLAIM IS MADE TO THE EXCLUSIVE RIGHT TO USE "RELIEF", APART FROM THE MARK AS SHOWN.

CLASS 36—INSURANCE AND FINANCIAL

FOR PHILANTHROPIC AND CHARITABLE SERVICES IN THE AREAS OF FUNDRAISING, AND SOLICITATION, COLLECTION AND DONATION OF FUNDS; CHARITABLE FUNDRAISING SERVICES THROUGH THE SALE OF EQUIPMENT, SUPPLIES, SALVAGED ITEMS AND DONATED ITEMS; AND CHARITABLE FUNDRAISING SERVICES, NAMELY, SPONSORING, DEVELOPING AND ASSISTING IN PROGRAMS TO FINANCE PARTICIPATION IN CHARITABLE PROGRAMS AND ACTIVITIES INVOLVING FURNISHING MEDICAL EQUIPMENT AND SUPPLIES, CONSTRUCTION, REPAIR, RENOVATION, EDUCATION, TRAINING AND ASSISTANCE FOR THE POOR AND DISADVANTAGED; AND SPONSORING CHARITABLE FUNDRAISING ACTIVITIES CONDUCTED BY INDIVIDUALS WHO PARTICIPATE IN CHARITABLE PROGRAMS AND ACTIVITIES INVOLVING FURNISHING MEDICAL EQUIPMENT AND SUPPLIES, CONSTRUCTION, REPAIR, RENOVATION, EDUCATION, TRAINING AND ASSISTANCE FOR THE POOR AND DISADVANTAGED (U.S. CLS. 100, 101 AND 102).

FIRST USE 1-31-2004; IN COMMERCE 1-31-2004.

CLASS 44—MEDICAL, BEAUTY AND AGRICULTURAL SERVICES

FOR PHILANTHROPIC AND CHARITABLE SERVICES, NAMELY, SOLICITING THE DONATION OF, AND DONATING TO OTHER ORGANIZATIONS AND INDIVIDUALS FOR USE BY THE NEEDY OF, MEDICAL EQUIPMENT, MEDICAL DEVICES, MEDICAL SUPPLIES, MEDICAL SERVICES, PHARMACEUTICALS, DIETARY SUPPLEMENTS, NUTRITIONAL SUPPLEMENTS, AND VITAMINS (U.S. CLS. 100 AND 101).

FIRST USE 1-31-2004; IN COMMERCE 1-31-2004.

MICHAEL WIENER, EXAMINING ATTORNEY

SN 85-103,028. IRON SOLUTIONS, INC., FENTON, MO.
FILED 8-9-2010.

PRODUCERS' CHOICE AWARD

THE MARK CONSISTS OF STANDARD CHARACTERS WITHOUT CLAIM TO ANY PARTICULAR FONT, STYLE, SIZE, OR COLOR.

NO CLAIM IS MADE TO THE EXCLUSIVE RIGHT TO USE "AWARD", APART FROM THE MARK AS SHOWN.

CLASS 35—ADVERTISING AND BUSINESS

FOR CONDUCTING INCENTIVE AWARD PROGRAMS TO PROMOTE THE QUALITY AND PRODUCTIVITY OF TRACTORS AND OTHER FARM, CONSTRUCTION, AND OUTDOOR POWER EQUIPMENT; INCENTIVE AWARD PROGRAMS TO PROMOTE THE SALE OF PRODUCTS AND SERVICES OF OTHERS; PROMOTING THE SALE AND RETAINED MARKET VALUES OF FARM, CONSTRUCTION, AND OUTDOOR POWER EQUIPMENT THROUGH THE ADMINISTRATION OF INCENTIVE AWARD PROGRAMS (U.S. CLS. 100, 101 AND 102).

CLASS 41—EDUCATION AND ENTERTAINMENT

FOR PROVIDING RECOGNITION AND INCENTIVES BY WAY OF AWARDS TO DEMONSTRATE EXCELLENCE IN THE FIELD OF EQUIPMENT USAGE AND APPLICATION; PROVIDING RECOGNITION BY WAY OF AN AWARD PROGRAM TO RECOGNIZE QUALITY, POPULARITY, AND ACHIEVEMENT IN THE AGRICULTURAL INDUSTRY (U.S. CLS. 100, 101 AND 107).

STEVEN JACKSON, EXAMINING ATTORNEY

SN 85-104,099. THE PROCTER & GAMBLE COMPANY,
CINCINNATI, OH. FILED 8-10-2010.



OWNER OF U.S. REG. NOS. 3,012,299, 3,525,696 AND OTHERS.

NO CLAIM IS MADE TO THE EXCLUSIVE RIGHT TO USE "FLAVORS & FRAGRANCES", APART FROM THE MARK AS SHOWN.

THE COLOR(S) BLUE AND WHITE IS/ARE CLAIMED AS A FEATURE OF THE MARK.

THE MARK CONSISTS OF A CIRCLE WITH A BLUE BACKGROUND CONTAINING ONE HALF SLICE OF FRUIT IN WHITE AND ONE HALF OF A FLOWER IN WHITE, NEXT TO THE WORDS "P&G FLAVOR & FRAGRANCES" IN BLUE LETTERING.

CLASS 1—CHEMICALS

FOR NATURAL, ARTIFICIAL AND SYNTHETIC AND BACTERICIDAL AND PRESERVATIVE CHEMICALS SOLD IN BULK FORM FOR USE AS AN INGREDIENT IN THE MANUFACTURE OF SOAPS, DETERGENTS AND PERFUMES; ARTIFICIAL AND SYNTHETIC PERFUME COMPOSITIONS SOLD IN BULK FORM FOR USE AS AN INGREDIENT IN THE MANUFACTURE OF COSMETICS AND PERFUMES (U.S. CLS. 1, 5, 6, 10, 26 AND 46).

CLASS 3—COSMETICS AND CLEANING PREPARATIONS

FOR ESSENTIAL OILS FOR COSMETIC AND PERFUMERY PRODUCTS, AND NON-MEDICATED SKIN CARE PREPARATIONS, NAMELY, PERFUMES, EAU DE TOILETTE, EAU DE COLOGNE, COSMETIC PREPARATIONS FOR PROTECTING THE SKIN FROM THE SUN'S RAYS AND SUN TANNING LOTIONS, LIPSTICKS, MAKE-UPS, SHOWER GELS, BUBBLE BATH, BODY SCRUBS, EXFOLIANTS, BODY SPRAYS, LOTIONS, NON-MEDICATED SKIN CARE CREAMS FOR THE FACE, SKIN, AND BODY, TALCUM POWDERS, ANTI-PERSPIRANTS, PERSONAL DEODORANTS, SKIN CONDITIONERS; HAIR CARE TREATMENTS, NAMELY, COLORING SHAMPOOS IN THE NATURE OF HAIR COLOR, NATURAL SHAMPOOS FOR THE HAIR, HAIR CONDITIONERS, HAIR SHINE ENHANCERS, HAIR SPRAYS; NATURAL, ARTIFICIAL AND SYNTHETIC ESSENTIAL OILS FOR USE IN THE MANUFACTURE OF COSMETIC AND PERFUMERY PRODUCTS; SOAPS, NAMELY, DETERGENTS, TOILET SOAPS, SHAVE PREPARATIONS, LAUNDRY PREPARATIONS, LAUNDRY DETERGENTS AND FABRIC SOFTENERS (U.S. CLS. 1, 4, 6, 50, 51 AND 52).

CLASS 30—STAPLE FOODS

FOR FLAVORING ADDITIVES FOR NON-NUTRITIONAL PURPOSES FOR OVER-THE-COUNTER MEDICINES (U.S. CL. 46).
NAPOLÉON SHARMA, EXAMINING ATTORNEY

SN 85-104,240. SUMMER'S SKY, LLC, FORT WAYNE, IN. FILED 8-10-2010.

SUMMER'S SKY

THE MARK CONSISTS OF STANDARD CHARACTERS WITHOUT CLAIM TO ANY PARTICULAR FONT, STYLE, SIZE, OR COLOR.

CLASS 35—ADVERTISING AND BUSINESS

FOR PROVIDING CONSUMER INFORMATION SERVICES AND REFERRALS IN THE FIELD OF CARING FOR SPECIAL NEEDS PERSONS; AND, PUBLIC ADVOCACY TO PROMOTE AWARENESS OF THE CONTRIBUTIONS AND CONCERNS OF SPECIAL NEEDS PERSONS, CAREGIVERS, AND PROFESSIONALS (U.S. CLS. 100, 101 AND 102).

CLASS 45—PERSONAL AND LEGAL SERVICES

FOR PROVIDING PERSONAL SUPPORT SERVICES TO SPECIAL NEEDS PERSONS, CAREGIVERS, AND PROFESSIONALS, NAMELY, PATIENT ADVOCATE SERVICES FOR SPECIAL NEEDS PERSONS; AND, ORGANIZING AND CONDUCTING SUPPORT GROUPS IN THE FIELD OF SPECIAL NEEDS PERSONS, CAREGIVERS, AND PROFESSIONALS (U.S. CLS. 100 AND 101).

MICHAEL LITZAU, EXAMINING ATTORNEY

SN 85-104,602. GILMORE, KIM RAYMOND, DBA RENTMYFUN.COM, CHARLOTTE, NC. FILED 8-10-2010.

rentmyfun.com

THE MARK CONSISTS OF STANDARD CHARACTERS WITHOUT CLAIM TO ANY PARTICULAR FONT, STYLE, SIZE, OR COLOR.

CLASS 35—ADVERTISING AND BUSINESS

FOR PROVIDING A WEB SITE THAT FEATURES AN ON-LINE MARKET FOR USERS TO LIST OFFERED OR WANTED PERSONAL AND BUSINESS ASSETS AND SKILLS FOR HIRE, RENT, SALE OR AUCTION TRANSACTED ON THE BASIS OF PREDEFINED PERFORMANCE AND CLOSING TERMS AND CONDITIONS; PROVIDING A WEBSITE WHERE OWNERS CAN POST ITEMS AND SERVICES AVAILABLE FOR RENT BY OTHERS (U.S. CLS. 100, 101 AND 102).

CLASS 36—INSURANCE AND FINANCIAL

FOR RENT COLLECTION; RENT COLLECTION AGENCIES (U.S. CLS. 100, 101 AND 102).
KELLEY WELLS, EXAMINING ATTORNEY

SN 85-107,100. SBA TELECOMMUNICATIONS, INC., BOCA RATON, FL. FILED 8-13-2010.

COSTA PACÍFICO

PRIORITY CLAIMED UNDER SEC. 44(D) ON PANAMA APPLICATION NO. 191385, FILED 7-5-2010, REG. NO. 19138501, DATED 7-5-2010, EXPIRES 7-5-2020.

PRIORITY CLAIMED UNDER SEC. 44(D) ON PANAMA APPLICATION NO. 191382, FILED 7-5-2010, REG. NO. 19138201, DATED 7-5-2010, EXPIRES 7-5-2020.

PRIORITY CLAIMED UNDER SEC. 44(D) ON PANAMA APPLICATION NO. 191383, FILED 7-5-2010, REG. NO. 19138301, DATED 7-5-2010, EXPIRES 7-5-2020.

PRIORITY CLAIMED UNDER SEC. 44(D) ON PANAMA APPLICATION NO. 191386, FILED 7-5-2010, REG. NO. 19138601, DATED 7-5-2010, EXPIRES 7-5-2020.

PRIORITY CLAIMED UNDER SEC. 44(D) ON PANAMA APPLICATION NO. 191387, FILED 7-5-2010, REG. NO. 19138401, DATED 7-5-2010, EXPIRES 7-5-2020.

PRIORITY CLAIMED UNDER SEC. 44(D) ON PANAMA APPLICATION NO. 191388, FILED 7-5-2010, REG. NO. 19138801, DATED 7-5-2010, EXPIRES 7-5-2020.

THE MARK CONSISTS OF THE WORDS "COSTA PACIFICO", THE FIRST "I" IN "PACIFICO" HAVING AN ACCENT OVER IT AND WHEREIN THE BOTTOM HALF OF THE LETTERING INCLUDES DARKER SHADING, ALL DISPOSED BELOW THREE WAVES, WHEREIN (1) THE MIDDLE WAVE IS THE LARGEST -RUNNING FROM ABOVE THE "C" IN "COSTA" TO ABOVE THE SECOND "C" IN "PACIFICO" - AND INCLUDES DARKER SHADING AT THE RIGHTHAND END OF THE WAVE; (2) THE LOWER WAVE IS NARROWER AND SHORTER THAN THE MIDDLE WAVE - RUNNING FROM ABOVE THE "O" IN "COSTA" TO ABOVE THE FIRST "C" IN "PACIFICO" - AND INCLUDES DARKER SHADING AT THE RIGHTHAND END OF THE WAVE; AND (3) THE UPPER WAVE IS NARROWER AND SHORTER THAN BOTH OTHER WAVES - RUNNING FROM ABOVE THE "A" IN "PACIFICO" TO ABOVE THE SECOND "C" IN "PACIFICO" - AND INCLUDES DARKER SHADING AT THE RIGHTHAND END OF THE WAVE.

THE ENGLISH TRANSLATION OF "COSTA PACÍFICO" IS PACIFIC COAST.

SN 85-107,335. GREESON, AMY, HIGH POINT, NC. FILED 8-13-2010.

HEALING SEEKERS

CLASS 9—ELECTRICAL AND SCIENTIFIC APPARATUS

FOR TELECOMMUNICATIONS TOWERS (U.S. CLS. 21, 23, 26, 36 AND 38).

CLASS 25—CLOTHING

FOR CLOTHING, NAMELY, HATS AND SHIRTS (U.S. CLS. 22 AND 39).

CLASS 36—INSURANCE AND FINANCIAL

FOR TRANSMISSION SITE LAND ACQUISITION, NAMELY, REAL ESTATE BROKERAGE AND LEASING (U.S. CLS. 100, 101 AND 102).

CLASS 37—CONSTRUCTION AND REPAIR

FOR ANTENNA TOWER CONSTRUCTION; CONSTRUCTION OF TELECOMMUNICATION TOWERS AND BASE STATIONS; INSTALLATION OF ANTENNAS AND TELECOMMUNICATIONS EQUIPMENT; CONSULTING SERVICES IN THE FIELD OF INSTALLATION OF TELECOMMUNICATIONS INFRASTRUCTURE AND TELECOMMUNICATIONS CONSTRUCTION PROJECT MANAGEMENT (U.S. CLS. 100, 103 AND 106).

CLASS 38—COMMUNICATION

FOR PROVIDING THIRD PARTY USERS WITH ACCESS TO TELECOMMUNICATIONS INFRASTRUCTURE; LEASING OF TELECOMMUNICATIONS EQUIPMENT (U.S. CLS. 100, 101 AND 104).

CLASS 42—SCIENTIFIC AND COMPUTER SERVICES

FOR CONSULTING SERVICES IN THE FIELD OF TELECOMMUNICATIONS TECHNOLOGY; TELECOMMUNICATIONS SYSTEMS INTEGRATION SERVICES; ENGINEERING SERVICES IN THE FIELD OF TELECOMMUNICATIONS POWER PLANTS AND DISTRIBUTION SYSTEMS (U.S. CLS. 100 AND 101).

CYNTHIA SLOAN, EXAMINING ATTORNEY

THE MARK CONSISTS OF STANDARD CHARACTERS WITHOUT CLAIM TO ANY PARTICULAR FONT, STYLE, SIZE, OR COLOR.

NO CLAIM IS MADE TO THE EXCLUSIVE RIGHT TO USE "HEALING", APART FROM THE MARK AS SHOWN.

CLASS 41—EDUCATION AND ENTERTAINMENT

FOR ENTERTAINMENT IN THE NATURE OF ON-LINE NONDOWNLOADABLE WEBINARS AND BLOGS FEATURING TRADITIONAL MEDICINAL AND ALTERNATIVE THERAPIES, PLANTS AND ORGANISMS USED IN AND AS TRADITIONAL MEDICINAL AND ALTERNATIVE THERAPIES, CONSERVATION AND ENVIRONMENTAL ISSUES AS THEY RELATE TO TRADITIONAL MEDICINAL AND ALTERNATIVE THERAPIES, AND MEDICINAL PLANTS AND ENDANGERED SPECIES; PRODUCTION OF VIDEOS, WEBINARS AND AUDIO PROGRAMS FEATURING TRADITIONAL MEDICINAL AND ALTERNATIVE THERAPIES AND PLANTS AND ORGANISMS USED IN AND AS TRADITIONAL MEDICINAL AND ALTERNATIVE THERAPIES, CONSERVATION AND ENVIRONMENTAL ISSUES AS THEY RELATE TO TRADITIONAL MEDICINAL AND ALTERNATIVE THERAPIES, AND MEDICINAL PLANTS AND ENDANGERED SPECIES; EDUCATIONAL SERVICES, NAMELY, CONDUCTING WORKSHOPS, SEMINARS, WEBINARS AND TEACHING CLASSES IN THE SUBJECT OF TRADITIONAL MEDICINAL AND ALTERNATIVE THERAPIES, AND PLANTS AND ORGANISMS USED IN AND AS TRADITIONAL MEDICINAL AND ALTERNATIVE THERAPIES, AND CONSERVATION AND ENVIRONMENTAL ISSUES AS THEY RELATE TO TRADITIONAL MEDICINAL AND ALTERNATIVE THERAPIES, AND MEDICINAL PLANTS AND ENDANGERED SPECIES; EDUCATIONAL SERVICES, NAMELY, CONDUCTING WORKSHOPS, SEMINARS, WEBINARS AND TEACHING CLASSES IN THE SUBJECT OF TRADITIONAL MEDICINAL AND ALTERNATIVE THERAPIES, AND PLANTS AND ORGANISMS USED IN AND AS TRADITIONAL MEDICINAL AND ALTERNATIVE THERAPIES, AND CONSERVATION AND ENVIRONMENTAL ISSUES AS THEY RELATE TO TRADITIONAL MEDICINAL AND ALTERNATIVE THERAPIES, AND MEDICINAL PLANTS AND ENDANGERED SPECIES (U.S. CLS. 100, 101 AND 107).

FIRST USE 7-27-2006; IN COMMERCE 7-27-2006.

CLASS 42—SCIENTIFIC AND COMPUTER SERVICES

FOR RESEARCH IN THE FIELD OF TRADITIONAL MEDICINE, MEDICAL BOTANY, CHEMISTRY AND PHARMACOLOGY, HERBAL MEDICINE, INDIGENOUS HEALING THERAPIES, COMPLEMENTARY, INTEGRATIVE, AND ALTERNATIVE MEDICINE, NATURAL HEALTH PRODUCTS AND TREATMENTS; PROVIDING SCIENTIFIC INFORMATION IN THE FIELD OF ENVIRONMENTAL CONSERVATION AND SUSTAINABILITY PRACTICES AND ISSUES (U.S. CLS. 100 AND 101).

FIRST USE 7-27-2006; IN COMMERCE 7-27-2006.

CLASS 44—MEDICAL, BEAUTY AND AGRICULTURAL SERVICES

FOR MEDICAL AND HEALTH INFORMATION SERVICES FEATURING INFORMATION REGARDING TRADITIONAL MEDICINAL, INDIGENOUS HEALING THERAPIES, AND ALTERNATIVE THERAPIES, AND PLANTS AND ORGANISMS USED IN AND AS TRADITIONAL MEDICINAL AND ALTERNATIVE THERAPIES, AND MEDICINAL PLANTS AND ALL LIFE SPECIES; PROVIDING A WEBSITE FEATURING ONLINE NONDOWNLOADABLE VIDEOS IN THE FIELDS OF TRADITIONAL MEDICINAL AND ALTERNATIVE THERAPIES, PLANTS AND ORGANISMS USED IN AND AS TRADITIONAL MEDICINAL AND ALTERNATIVE THERAPIES AND CONSERVATION AND ENVIRONMENTAL ISSUES AS THEY RELATE TO TRADITIONAL MEDICINAL AND ALTERNATIVE THERAPIES AND MEDICINAL PLANTS AND ENDANGERED SPECIES (U.S. CLS. 100 AND 101).

FIRST USE 7-27-2006; IN COMMERCE 7-27-2006.
DOUGLAS LEE, EXAMINING ATTORNEY

SN 85-107,972. AMCO INTERNATIONAL LLC, COCONUT GROVE, FL. FILED 8-16-2010.

SENZZI

THE MARK CONSISTS OF STANDARD CHARACTERS WITHOUT CLAIM TO ANY PARTICULAR FONT, STYLE, SIZE, OR COLOR.

THE WORDING "SENZZI" HAS NO MEANING IN A FOREIGN LANGUAGE.

CLASS 8—HAND TOOLS

FOR PERSONAL CARE APPLIANCES, NAMELY, ELECTRIC HAIR TRIMMERS, ELECTRIC SHAVERS, AND ELECTROLYSIS APPARATUSES FOR HAIR REMOVAL (U.S. CLS. 23, 28 AND 44).

CLASS 9—ELECTRICAL AND SCIENTIFIC APPARATUS

FOR ELECTRIC CURLING IRONS (U.S. CLS. 21, 23, 26, 36 AND 38).

PAUL E. FAHRENKOPF, EXAMINING ATTORNEY

SN 85-107,985. AMCO INTERNATIONAL LLC, COCONUT GROVE, FL. FILED 8-16-2010.

EVOL

THE MARK CONSISTS OF STANDARD CHARACTERS WITHOUT CLAIM TO ANY PARTICULAR FONT, STYLE, SIZE, OR COLOR.

CLASS 7—MACHINERY

FOR POWER OPERATED TOOLS, NAMELY, DRILLS, GRINDERS, JIGSAWS, CIRCULAR SAWS, AND SANDERS (U.S. CLS. 13, 19, 21, 23, 31, 34 AND 35).

CLASS 8—HAND TOOLS

FOR HAND TOOLS, NAMELY, PLIERS, WIRE CUTTERS, AND SNIPS; PERSONAL CARE APPLIANCES, NAMELY, ELECTRIC HAIR TRIMMERS, ELECTRIC SHAVERS, AND ELECTROLYSIS APPARATUSES FOR HAIR REMOVAL (U.S. CLS. 23, 28 AND 44).

PAUL E. FAHRENKOPF, EXAMINING ATTORNEY

SN 85-109,385. OBRASCON HUARTE LAIN, S.A., MADRID, SPAIN, FILED 8-17-2010.



OWNER OF U.S. REG. NO. 3,833,400.

NO CLAIM IS MADE TO THE EXCLUSIVE RIGHT TO USE "TOWER" AND "GROUP", APART FROM THE MARK AS SHOWN.

THE COLOR(S) BLUE, YELLOW, RED, OCHRE, BEIGE, WHITE IS/ARE CLAIMED AS A FEATURE OF THE MARK.

THE MARK CONSISTS OF THE WORD "TOWER" WRITTEN IN STYLIZED BLUE LETTERS AND BELOW IT IS A BLUE HORIZONTAL LINE AND BELOW THIS LINE ARE THE WORDS "OHL GROUP" IN STYLIZED BLUE LETTERS OF SMALLER SIZE; TO THE LEFT OF THIS WORDING IS THE DESIGN OF A TOWER INSIDE A BEIGE AND WHITE RECTANGLE, UPPER LEFT SIDE OF THE TOWER IS IN RED AND THE REMAINDER OF THE TOWER IS IN OCHRE. THE ENTIRE MARK IS SET ON A YELLOW BACKGROUND RECTANGLE.

CLASS 36—INSURANCE AND FINANCIAL

FOR FINANCIAL AFFAIRS AND MONETARY AFFAIRS, NAMELY, FINANCIAL INFORMATION, MANAGEMENT AND ANALYSIS SERVICES; BANKING; REAL ESTATE AFFAIRS, NAMELY, REAL ESTATE LISTING SERVICES, REAL ESTATE MANAGEMENT SERVICES, REAL ESTATE CONSULTATION (U.S. CLS. 100, 101 AND 102).

CLASS 37—CONSTRUCTION AND REPAIR

FOR BUILDING CONSTRUCTIONS; BUILDING REPAIR; INSTALLATION OF BUILDING INSULATION (U.S. CLS. 100, 103 AND 106).

CLASS 42—SCIENTIFIC AND COMPUTER SERVICES

FOR SCIENTIFIC AND TECHNOLOGICAL SERVICES AND RESEARCH AND DESIGN RELATING THERETO, NAMELY, ARCHITECTURAL DESIGN, CONSULTING SERVICES IN THE FIELD OF ARCHITECTURAL DESIGN, CONSULTING IN THE FIELDS OF ENGINEERING AND ARCHITECTURE, CONSTRUCTION DRAFTING, GEOLOGICAL SURVEYS OR RESEARCH, TECHNOLOGY CONSULTATION AND RESEARCH IN THE FIELD OF ENGINEERING AND GEOLOGY, TECHNOLOGY CONSULTATION BY EXPERTS IN THE FIELD OF ARCHITECTURE, ENGINEERING AND GEOLOGY; DESIGN AND DEVELOPMENT OF COMPUTER HARDWARE AND SOFTWARE IN THE FIELD OF ARCHITECTURE, ENGINEERING, CONSTRUCTION AND GEOLOGY (U.S. CLS. 100 AND 101).

REBECCA GILBERT, EXAMINING ATTORNEY

SN 85-110,081. ASCENA RETAIL GROUP, INC., SUFFERN, NY. FILED 8-18-2010.

ASCENA

THE MARK CONSISTS OF STANDARD CHARACTERS WITHOUT CLAIM TO ANY PARTICULAR FONT, STYLE, SIZE, OR COLOR.

THE ENGLISH TRANSLATION OF "ASCENA" IN THE MARK IS UPWARDS.

CLASS 35—ADVERTISING AND BUSINESS

FOR CONDUCTING SHAREHOLDER AND INVESTOR RELATIONS, NAMELY, PROVIDING SHAREHOLDER RECORD KEEPING AND CORPORATE BUSINESS INFORMATION AND ANALYSES (U.S. CLS. 100, 101 AND 102).

CLASS 36—INSURANCE AND FINANCIAL

FOR ADMINISTRATION OF BENEFIT PLANS AND WELFARE BENEFIT PLANS CONCERNING INSURANCE AND FINANCE, PROVIDED TO EMPLOYEES AND EMPLOYEES OF AFFILIATES AND SUBSIDIARIES; FINANCIAL ADMINISTRATION OF RETIREMENT PLANS PROVIDED TO EMPLOYEES AND EMPLOYEES OF AFFILIATES AND SUBSIDIARIES, INCLUDING STOCK OPTION PLANS, RESTRICTED STOCK PLANS, 401K RETIREMENT PLAN, EMPLOYEE STOCK PURCHASE PLAN (U.S. CLS. 100, 101 AND 102).
KAREN SEVERSON, EXAMINING ATTORNEY

SN 85-110,093. ASCENA RETAIL GROUP, INC., SUFFERN, NY. FILED 8-18-2010.

ASCENA RETAIL GROUP

THE MARK CONSISTS OF STANDARD CHARACTERS WITHOUT CLAIM TO ANY PARTICULAR FONT, STYLE, SIZE, OR COLOR.

NO CLAIM IS MADE TO THE EXCLUSIVE RIGHT TO USE "RETAIL GROUP", APART FROM THE MARK AS SHOWN.

THE ENGLISH TRANSLATION OF "ASCENA" IN THE MARK IS UPWARDS.

CLASS 35—ADVERTISING AND BUSINESS

FOR CONDUCTING SHAREHOLDER AND INVESTOR RELATIONS, NAMELY, PROVIDING SHAREHOLDER RECORD KEEPING AND CORPORATE BUSINESS INFORMATION AND ANALYSES (U.S. CLS. 100, 101 AND 102).

CLASS 36—INSURANCE AND FINANCIAL

FOR ADMINISTRATION OF BENEFIT PLANS AND WELFARE BENEFIT PLANS CONCERNING INSURANCE AND FINANCE, PROVIDED TO EMPLOYEES AND EMPLOYEES OF AFFILIATES AND SUBSIDIARIES; FINANCIAL ADMINISTRATION OF RETIREMENT PLANS PROVIDED TO EMPLOYEES AND EMPLOYEES OF AFFILIATES AND SUBSIDIARIES, INCLUDING STOCK OPTION PLANS, RESTRICTED STOCK PLANS, 401K RETIREMENT PLAN, EMPLOYEE STOCK PURCHASE PLAN (U.S. CLS. 100, 101 AND 102).
KAREN SEVERSON, EXAMINING ATTORNEY

SN 85-110,878. RED CHIP COMPANY LTD., ROAD TOWN, TORTOLA, BR.VIRGIN ISLANDS, FILED 8-19-2010.



OWNER OF U.S. REG. NOS. 2,145,051 AND 3,128,660.

THE MARK CONSISTS OF A TRIANGLE WITH ROUND EDGES WITH A STYLIZED EAR COMPRISED OF TWO PARTIAL OVALS INSIDE, AND THE WORD "BEHRINGER" IN LOWER CASE LETTERS APPEARING UNDERNEATH.

CLASS 9—ELECTRICAL AND SCIENTIFIC APPARATUS

FOR APPARATUS FOR RECORDING, TRANSMISSION, PROCESSING, AND REPRODUCTION OF SOUND; APPARATUS FOR CREATING, RETRIEVAL, MANIPULATION OF SOUND, NAMELY, AUDIO MIXERS; FEEDBACK SUPPRESSORS; AUDIO ENHANCERS AND EXCITERS; MICROPHONES; MICROPHONE PRE-AMPLIFIERS; DIRECT INPUT BOXES; MIXING CONSOLES; DYNAMIC PROCESSORS; EFFECTS AND SIGNAL PROCESSORS; EQUALIZERS; CROSSOVERS; AUDIO CONTROLLERS; AUDIO INTERFACES; SIGNAL DISTRIBUTION DEVICES; SIGNAL CONVERTERS; HEADPHONE AMPLIFIERS; HEADPHONES; POWER AMPLIFIERS; LOUDSPEAKERS; LIGHTING CONTROLS; COMPUTER SOFTWARE FOR CREATING, RECORDING, TRANSMISSION, PROCESSING, RETRIEVAL, MANIPULATION AND REPRODUCTION OF SOUND; DOWNLOADABLE ELECTRONIC PUBLICATIONS, NAMELY, MANUALS IN THE FIELD OF MUSIC, E.G. MUSICAL INSTRUMENTS AND ACCESSORIES, AND ELECTRONIC SOUND EQUIPMENT RELATED THERETO (U.S. CLS. 21, 23, 26, 36 AND 38).

CLASS 15—MUSICAL INSTRUMENTS

FOR MUSICAL INSTRUMENTS; GUITARS; PIANOS; SYNTHESIZERS; MUSICAL INSTRUMENT ACCESSORIES, NAMELY, STRINGS, CARRYING BAGS, STORAGE BAGS; CASES AND FOOT PEDALS FOR MUSICAL INSTRUMENTS; TUNING APPARATUS FOR MUSICAL INSTRUMENTS; AND REPLACEMENT PARTS THEREFOR (U.S. CLS. 2, 21 AND 36).

JOHN SCHUYLER YARD, EXAMINING ATTORNEY

SN 85-111,614. MERCURY PAYMENT SYSTEMS, LLC,
DURANGO, CO. FILED 8-19-2010.

SN 85-111,790. GREENDISK, INC., ISSAQUAH, WA. FILED
8-19-2010.

MERCURYSHIELD

THE MARK CONSISTS OF STANDARD CHARACTERS WITHOUT CLAIM TO ANY PARTICULAR FONT, STYLE, SIZE, OR COLOR.

OWNER OF U.S. REG. NOS. 3,526,213, 3,623,390 AND 3,623,646.

CLASS 9—ELECTRICAL AND SCIENTIFIC APPARATUS

FOR COMPUTER PROGRAMS FOR USE IN PAYMENT PROCESSING AND PAYMENT PROCESSING FRAUD PREVENTION AND PROTECTION, INCLUDING FOR USE IN CREDIT CARD, DEBIT CARD AND GIFT CARD TRANSACTION PROCESSING AND PAYMENT, AND USED TO OPERATE DATA ENTRY PERIPHERALS SUCH AS PIN PADS, MAGNETIC STRIP READERS KEYBOARDS, AND TOUCH SCREENS, AND USED TO PROVIDE END-TO-END ENCRYPTION AND TOKENIZATION OF FINANCIAL AND PERSONAL DATA FOR SECURING AND PROCESSING CREDIT CARD, DEBIT CARD AND GIFT CARD TRANSACTIONS; ALL OF THE FOREGOING EXCLUDES FLORISTS (U.S. CLS. 21, 23, 26, 36 AND 38).

CLASS 35—ADVERTISING AND BUSINESS

FOR INTEGRATED PAYMENT PROCESSING, NAMELY, BILLING (U.S. CLS. 100, 101 AND 102).

CLASS 36—INSURANCE AND FINANCIAL

FOR INTEGRATED PAYMENT PROCESSING, NAMELY, ELECTRONIC BILL PAYMENT PROCESSING; INTEGRATED PAYMENT PROCESSING, NAMELY, ELECTRONIC PAYMENT OF CREDIT CARD, DEBIT CARD AND GIFT CARD TRANSACTIONS FOR USE WITH POINT-OF-SALE, ONLINE, AND ELECTRONIC CASH REGISTER SYSTEMS SERVICES; ALL OF THE FOREGOING EXCLUDES FLORISTS (U.S. CLS. 100, 101 AND 102).

CLASS 42—SCIENTIFIC AND COMPUTER SERVICES

FOR PROVIDING TEMPORARY USE OF ONLINE NONDOWNLOADABLE COMPUTER PROGRAMS FOR USE IN PAYMENT PROCESSING AND PAYMENT PROCESSING FRAUD PREVENTION AND PROTECTION, INCLUDING FOR USE IN CREDIT CARD, DEBIT CARD AND GIFT CARD TRANSACTION PROCESSING AND PAYMENT, AND USED TO OPERATE DATA ENTRY PERIPHERALS SUCH AS PIN PADS, MAGNETIC STRIP READERS KEYBOARDS, AND TOUCH SCREENS, AND USED TO PROVIDE END-TO-END ENCRYPTION AND TOKENIZATION OF FINANCIAL AND PERSONAL DATA FOR SECURING AND PROCESSING CREDIT CARD, DEBIT CARD AND GIFT CARD TRANSACTIONS; ALL OF THE FOREGOING EXCLUDES FLORISTS (U.S. CLS. 100 AND 101).

HEATHER BIDDULPH, EXAMINING ATTORNEY

GREENDISK

THE MARK CONSISTS OF STANDARD CHARACTERS WITHOUT CLAIM TO ANY PARTICULAR FONT, STYLE, SIZE, OR COLOR.

CLASS 16—PAPER GOODS AND PRINTED MATTER

FOR CARDBOARD BOXES, FOR USE AS COLLECTION POINTS FOR RECYCLABLE ELECTRONIC MATERIAL, NAMELY, ELECTRONIC MEDIA, COMPACT DISKS, DISKETTES, DVDS, VIDEOTAPE, PRINTER INK CARTRIDGES, CELL PHONES, PAGERS, PDAS, COMPUTERS AND LAPTOPS (U.S. CLS. 2, 5, 22, 23, 29, 37, 38 AND 50).

FIRST USE 12-15-1993; IN COMMERCE 12-15-1993.

CLASS 37—CONSTRUCTION AND REPAIR

FOR COLLECTION CENTERS FOR ELECTRONIC MEDIA, COMPACT DISKS, DISKETTES, DVDS, VIDEOTAPE, AUDIO TAPE, PRINTER INK AND TONER CARTRIDGES, CELL PHONES, PAGERS, PDAS, COMPUTERS, LAPTOPS, MONITORS, PERIPHERALS, CORDS, CABLES, MICE, PRINTED CIRCUIT BOARDS RELATED THERETO (U.S. CLS. 100, 103 AND 106).

FIRST USE 11-12-1992; IN COMMERCE 2-22-1993.

CLASS 40—MATERIAL TREATMENT

FOR RECYCLING SERVICES, NAMELY, COLLECTION AND MATERIAL TREATMENT, FOR ELECTRONIC MATERIALS INCLUDING ELECTRONIC MEDIA, COMPACT DISKS, DISKETTES, DVDS, VIDEOTAPE, AUDIO TAPE, PRINTER INK AND TONER CARTRIDGES, CELL PHONES, PAGERS, PDAS, COMPUTERS, LAPTOPS, MONITORS, PERIPHERALS, CORDS, CABLES, MICE, PRINTED CIRCUIT BOARDS RELATED THERETO; MATERIAL TREATMENT TO REMOVE STORED DATA FROM ELECTRONIC MATERIALS, NAMELY, ELECTRONIC MEDIA, COMPACT DISKS, DISKETTES, DVDS, VIDEOTAPE, AUDIO TAPE, PRINTER INK AND TONER CARTRIDGES, CELL PHONES, PAGERS, PDAS, COMPUTERS, LAPTOPS; AND MATERIAL TREATMENT AND RECYCLING SERVICES CONSISTING IN THE PREPARATION OF YIELD MATERIALS, NAMELY, RECYCLED PLASTICS AND OTHER MATERIALS, THAT ARE YIELDED FROM THE RECYCLING PROCESS FOR REUSE IN OR REMANUFACTURE INTO NEW MATERIALS (U.S. CLS. 100, 103 AND 106).

FIRST USE 11-12-1992; IN COMMERCE 2-22-1993.

GINA HAYES, EXAMINING ATTORNEY

SN 85-111,948. MITSUBISHI ELECTRIC EUROPE B.V. SUCURSAL EN ESPANA, SAN CUGAT DEL VALLES, SPAIN, FILED 8-20-2010.



THE COLOR(S) RED, YELLOW, BLUE AND BLACK IS/ ARE CLAIMED AS A FEATURE OF THE MARK.

THE MARK CONSISTS OF THE WORD "EASYGIFTS" IN CURSIVE WRITING WITH THE WORD "EASY" IN RED AND "GIFTS" IN BLACK. A DESIGN OF A WRAPPED BOX IN RED, YELLOW AND BLUE IS DISPLAYED TO THE RIGHT OF THE WORD JUST ABOVE THE LAST "S".

CLASS 9—ELECTRICAL AND SCIENTIFIC APPARATUS

FOR SCIENTIFIC, ELECTRIC, PHOTOGRAPHIC, CINEMATOGRAPHIC, OPTICAL, WEIGHING, MEASURING, SIGNALING AND TEACHING APPARATUS AND INSTRUMENTS, NAMELY, INTERACTIVE PHOTO KIOSKS FOR CAPTURING, PRINTING AND UPLOADING DIGITAL IMAGES FOR FUTURE USE; APPARATUS FOR RECORDING, FOR TRANSMISSION AND REPRODUCTION OF SOUND OR IMAGES; ELECTRONIC DIGITAL PHOTOGRAPHIC CAMERAS; VIDEO CAMERAS; BLANK MAGNETIC DATA CARRIERS, BLANK DISCS FOR COMPUTERS, BLANK MAGNETIC DISCS, BLANK OPTICAL DISCS, BLANK RECORDABLE CDS AND DVDS; EXPOSED CAMERA AND SLIDE FILMS; SPECIAL CASES FOR PHOTOGRAPHIC APPARATUS AND INSTRUMENTS; COMPACT DISC PLAYERS; COMPUTER OPERATING PROGRAMS; PRINTERS FOR USE WITH COMPUTERS; COMPUTER PERIPHERAL DEVICES; COMPUTERS; PHOTOCOPYING APPARATUS AND PHOTOCOPYING MACHINES; PROJECTION APPARATUS, NAMELY, PROJECTION SCREENS (U.S. CLS. 21, 23, 26, 36 AND 38).

CLASS 16—PAPER GOODS AND PRINTED MATTER

FOR PAPER; PRINTED MATTER, NAMELY, BLANK CARDS, PROSPECTUSES IN THE FIELD OF PHOTOGRAPHY AND AUDIO-VISUAL GOODS AND ACCESSORIES; POSTERS, PRINTED TICKETS, CALENDARS, NOTE BOOKS, PHOTOGRAPHS; STATIONERY; PHOTOALBUMS; PHOTOGRAPH STANDS (U.S. CLS. 2, 5, 22, 23, 29, 37, 38 AND 50).

CLASS 40—MATERIAL TREATMENT

FOR PHOTOGRAPHIC FILM DEVELOPMENT; PHOTOGRAPHIC PRINTING; PHOTOCOMPOSING SERVICES; PHOTOGRAVURE; PRINTING SERVICES (U.S. CLS. 100, 103 AND 106).

SUSAN RICHARDS, EXAMINING ATTORNEY

SN 85-112,168. ECOLICIOUS EQUESTRIAN INC., STE. ANNE, MANITOBA, CANADA, FILED 8-20-2010.

EcoLicious Equestrian

THE MARK CONSISTS OF STANDARD CHARACTERS WITHOUT CLAIM TO ANY PARTICULAR FONT, STYLE, SIZE, OR COLOR.

NO CLAIM IS MADE TO THE EXCLUSIVE RIGHT TO USE "EQUESTRIAN", APART FROM THE MARK AS SHOWN.

CLASS 3—COSMETICS AND CLEANING PREPARATIONS

FOR ECO-FRIENDLY HORSE GROOMING PREPARATIONS, NAMELY, NON-MEDICATED SHAMPOOS, NON-MEDICATED MANE AND TAIL DETANGLERS, NON-MEDICATED HOOF POLISHES, AND NON-MEDICATED COAT POLISHES (U.S. CLS. 1, 4, 6, 50, 51 AND 52).

CLASS 5—PHARMACEUTICALS

FOR ECO-FRIENDLY HORSE GROOMING PREPARATIONS, NAMELY, FLY REPELLANT SPRAYS (U.S. CLS. 6, 18, 44, 46, 51 AND 52).

APRIL ROACH, EXAMINING ATTORNEY

SN 85-113,453. NEW YORK CITY ICY COMPANY CORPORATION, DBA NYC ICY, BROOKLYN, NY. FILED 8-23-2010.

NYC ICY

THE MARK CONSISTS OF STANDARD CHARACTERS WITHOUT CLAIM TO ANY PARTICULAR FONT, STYLE, SIZE, OR COLOR.

NO CLAIM IS MADE TO THE EXCLUSIVE RIGHT TO USE "NYC", APART FROM THE MARK AS SHOWN. SEC. 2(F).

CLASS 30—STAPLE FOODS

FOR ICES AND ICE CREAMS (U.S. CL. 46).
FIRST USE 4-1-2002; IN COMMERCE 5-1-2002.

CLASS 35—ADVERTISING AND BUSINESS

FOR RETAIL ICE CREAM STORE SERVICES (U.S. CLS. 100, 101 AND 102).
FIRST USE 4-1-2002; IN COMMERCE 5-1-2002.
TRACY FLETCHER, EXAMINING ATTORNEY

SN 85-113,805. EDEN ENTERPRISE, INC., SKOKIE, IL. FILED 8-23-2010.

Eden

OWNER OF U.S. REG. NO. 3,646,306.

THE MARK CONSISTS OF THE TERM "EDEN" ADJACENT TO A FLYING BIRD HAVING A TREE BRANCH IN ITS BEAK.

CLASS 3—COSMETICS AND CLEANING PREPARATIONS

FOR EYE LINER; LIP LINER; MASCARA; EMERY BOARDS; FINGERNAIL RHINESTONES (U.S. CLS. 1, 4, 6, 50, 51 AND 52).

FIRST USE 8-1-1997; IN COMMERCE 8-1-1997.

CLASS 8—HAND TOOLS

FOR MANICURE AND PEDICURE IMPLEMENTS, NAMELY, NAIL FILES, NAIL CLIPPERS, NAIL SCISSORS AND CUTICLE SCISSORS; HAIRCARE IMPLEMENTS, NAMELY, TWEEZERS AND HAIR CUTTING SCISSORS (U.S. CLS. 23, 28 AND 44).

FIRST USE 8-1-1997; IN COMMERCE 8-1-1997.

CLASS 21—HOUSEWARES AND GLASS

FOR MANUAL COSMETIC CLEANERS, NAMELY, SPONGES AND BODY SCRUBBING PUFFS; HAIR COMBS; HAIR BRUSHES; MAKE-UP BRUSHES (U.S. CLS. 2, 13, 23, 29, 30, 33, 40 AND 50).

FIRST USE 8-1-1997; IN COMMERCE 8-1-1997.

CLASS 26—FANCY GOODS

FOR HAIR PINS; HAIR NETS; HAIR BANDS; PONY TAIL HAIR HOLDERS; HAIR BARRETTES; HAIR WEAVING KITS, CONSISTING OF THREADS AND NEEDLES; HAIR ORNAMENTS, NAMELY, DECORATIVE HAIR STONES (U.S. CLS. 37, 39, 40, 42 AND 50).

FIRST USE 8-1-1997; IN COMMERCE 8-1-1997.

SUSAN LESLIE DUBOIS, EXAMINING ATTORNEY

SN 85-114,172. BIOFILTER SYSTEMS, LLC, GAINESVILLE, FL. FILED 8-24-2010.



THE MARK CONSISTS OF STYLIZED LETTERS "B", "I" AND "O" CENTERED ABOVE THE DESIGN OF A SHADED LIQUID DROPLET WITH SHADED OVAL BASE AND SHADED BROKEN OVAL RIPPLES OR WAVES EMANATING THEREFROM WHERE THE LETTER "I" IS FORMED BY THE DROPLET.

CLASS 11—ENVIRONMENTAL CONTROL APPARATUS

FOR BIOREACTORS FOR USE IN THE TREATMENT OF WASTEWATER; ENVIRONMENTAL CONTROL APPARATUS, NAMELY, PARTICLE ACTIVATORS FOR USE IN SOIL REMEDIATION, DRINKING WATER TREATMENT, MUNICIPAL AND INDUSTRIAL WASTEWATER TREATMENT; FILTERS FOR FLUIDS, NAMELY, FOR WATER AND AREA-WATER SOLUTIONS; SUSTAINABLE ONSITE WATER RECYCLING AND WASTEWATER TREATMENT SYSTEMS; WATER FILTERS; WASTEWATER FILTERS; WASTEWATER FILTERS FOR USE IN THE FIELDS OF AQUACULTURE, AGRICULTURE AND INDUSTRY WASTEWATER; FILTERS FOR WASTEWATER CONTAINING ON-SITE HUMAN WASTE (U.S. CLS. 13, 21, 23, 31 AND 34).

CLASS 40—MATERIAL TREATMENT

FOR SUSTAINABLE ON-SITE WATER RECYCLING AND WASTEWATER TREATMENT SERVICES (U.S. CLS. 100, 103 AND 106).

KHANH LE, EXAMINING ATTORNEY

SN 85-114,198. KCD IP, LLC, HOFFMAN ESTATES, IL. FILED 8-24-2010.

DIEHARD

THE MARK CONSISTS OF STANDARD CHARACTERS WITHOUT CLAIM TO ANY PARTICULAR FONT, STYLE, SIZE, OR COLOR.

OWNER OF U.S. REG. NOS. 1,696,168, 3,096,741 AND OTHERS.

CLASS 9—ELECTRICAL AND SCIENTIFIC APPARATUS

FOR SUNGLASSES, GOGGLES FOR SPORTS, SAFETY GOGGLES, MOTORCYCLE GOGGLES, SKI GOGGLES, SNOW GOGGLES, SWIM GOGGLES, PROTECTIVE HELMETS, SPORTS HELMETS, SAFETY HELMETS, RIDING HELMETS, MOTORCYCLE HELMETS, BICYCLE HELMETS; COMPUTER BAGS (U.S. CLS. 21, 23, 26, 36 AND 38).

CLASS 14—JEWELRY

FOR WATCHES, JEWELRY (U.S. CLS. 2, 27, 28 AND 50).

CLASS 18—LEATHER GOODS

FOR WALLETS, BACKPACKS, DUFFLE BAGS, TOTE BAGS, MESSENGER BAGS, LUGGAGE, SUITCASES (U.S. CLS. 1, 2, 3, 22 AND 41).

CLASS 25—CLOTHING

FOR APPAREL, NAMELY, PANTS, JEANS, LEGGINGS, CAPRIS, SHORTS, SKORTS, SKIRTS, BOTTOMS, TOPS, SHIRTS, T-SHIRTS, TANK TOPS, VESTS, KNIT TOPS, SWEATERS, CARDIGANS, COATS, JACKETS, HEAD WEAR, HATS, HEADBANDS, EAR BANDS, EAR MUFFS, SCARVES, GLOVES, MITTENS, FLEECE TOPS, UNDERWEAR, THERMAL UNDERWEAR, BOXER BRIEFS, SOCKS, LOUNGEWEAR, PAJAMAS, SLEEP PANTS, SLEEP SHIRTS, ROBES, BOXER SHORTS, FLEECE BOTTOMS, HOODED SWEATSHIRTS, SWEATSHIRTS, SWEATPANTS, WIND PANTS, WIND JACKETS, YOGA PANTS, YOGA SHIRTS AND ATHLETIC WEAR, NAMELY, PANTS, CAPRIS, SHORTS, TANK TOPS, SHIRTS; FOOTWEAR (U.S. CLS. 22 AND 39).

JOHN GARTNER, EXAMINING ATTORNEY

SN 85-114,490. STRANDED FOODIE, LLC, RALEIGH, NC. FILED 8-24-2010.

STRANDED FOODIE

THE MARK CONSISTS OF STANDARD CHARACTERS WITHOUT CLAIM TO ANY PARTICULAR FONT, STYLE, SIZE, OR COLOR.

NO CLAIM IS MADE TO THE EXCLUSIVE RIGHT TO USE "FOODIE" FOR INTERNATIONAL CLASS 35, APART FROM THE MARK AS SHOWN.

CLASS 25—CLOTHING

FOR CLOTHING, NAMELY, APRONS, TOQUES, BASEBALL CAPS, VISORS; SHIRTS, NAMELY, POLO SHIRTS, T-SHIRTS, AND CHEF'S COATS (U.S. CLS. 22 AND 39).

SN 85-115,498. KOHR BROTHERS, INC., CHARLOTTESVILLE, VA. FILED 8-25-2010.

CLASS 35—ADVERTISING AND BUSINESS

FOR ONLINE RETAIL STORE SERVICES FEATURING FOOD, BOOKS, AND CLOTHING (U.S. CLS. 100, 101 AND 102).

MICHAEL LITZAU, EXAMINING ATTORNEY

FOUR BROTHERS

THE MARK CONSISTS OF STANDARD CHARACTERS WITHOUT CLAIM TO ANY PARTICULAR FONT, STYLE, SIZE, OR COLOR.

SN 85-114,842. DIAMOND DIAGNOSTICS INC., HOLLISTON, MA. FILED 8-24-2010.

DIAMOND DIAGNOSTICS**CLASS 30—STAPLE FOODS**

FOR FROZEN CUSTARD, FRUIT SORBET, ICE CREAM, ICE MILK AND FROZEN YOGURT, AND MILKSHAKES (U.S. CL. 46).

CLASS 43—HOTEL AND RESTAURANT SERVICES

FOR SERVING OF FOOD AND DRINK/BEVERAGES, NAMELY, SERVING OF FROZEN DESSERTS, ICE CREAM AND FROZEN CUSTARD, AND NOT INCLUDING RESTAURANT SERVICES (U.S. CLS. 100 AND 101).
JAY BESCH, EXAMINING ATTORNEY

THE MARK CONSISTS OF STANDARD CHARACTERS WITHOUT CLAIM TO ANY PARTICULAR FONT, STYLE, SIZE, OR COLOR.

NO CLAIM IS MADE TO THE EXCLUSIVE RIGHT TO USE "DIAGNOSTICS", APART FROM THE MARK AS SHOWN.

SN 85-115,557. APPROPRIATE SOLUTIONS, INC., PETERBOROUGH, NH. FILED 8-25-2010.

CLASS 1—CHEMICALS

FOR DIAGNOSTIC REAGENTS AND PREPARATIONS FOR CLINICAL USE (U.S. CLS. 1, 5, 6, 10, 26 AND 46).
FIRST USE 5-11-2001; IN COMMERCE 5-1-2001.

**PAYMENT PROCESSING
SIMPLIFIED****CLASS 9—ELECTRICAL AND SCIENTIFIC APPARATUS**

FOR CONSUMABLES FOR LABORATORY USE, NAMELY, REAGENTS AND ELECTRODES (U.S. CLS. 21, 23, 26, 36 AND 38).
FIRST USE 5-11-2001; IN COMMERCE 5-11-2001.

THE MARK CONSISTS OF STANDARD CHARACTERS WITHOUT CLAIM TO ANY PARTICULAR FONT, STYLE, SIZE, OR COLOR.

NO CLAIM IS MADE TO THE EXCLUSIVE RIGHT TO USE "PAYMENT PROCESSING", APART FROM THE MARK AS SHOWN.

CLASS 10—MEDICAL APPARATUS

FOR APPARATUS FOR CLINICAL DIAGNOSIS (U.S. CLS. 26, 39 AND 44).
FIRST USE 6-25-1997; IN COMMERCE 6-25-1997.

CLASS 9—ELECTRICAL AND SCIENTIFIC APPARATUS

FOR COMPUTER PROGRAMS FOR FINANCIAL TRANSACTIONS PROCESSING (U.S. CLS. 21, 23, 26, 36 AND 38).
FIRST USE 9-22-2007; IN COMMERCE 9-22-2007.

CLASS 37—CONSTRUCTION AND REPAIR

FOR REFURBISHMENT OF CLINICAL INSTRUMENTATION AND APPARATUS (U.S. CLS. 100, 103 AND 106).
FIRST USE 1-12-1999; IN COMMERCE 1-12-1999.

CLASS 42—SCIENTIFIC AND COMPUTER SERVICES**CLASS 42—SCIENTIFIC AND COMPUTER SERVICES**

FOR DEVELOPMENT OF CLINICAL INSTRUMENTATION AND APPARATUS (U.S. CLS. 100 AND 101).
FIRST USE 11-6-2006; IN COMMERCE 11-6-2006.
WILLIAM BRECKENFELD, EXAMINING ATTORNEY

FOR COMPUTER PROGRAMMING FOR OTHERS; TECHNICAL SUPPORT SERVICES, NAMELY, TROUBLESHOOTING OF COMPUTER SOFTWARE PROBLEMS; MAINTENANCE AND UPGRADING OF COMPUTER SOFTWARE (U.S. CLS. 100 AND 101).
FIRST USE 9-22-2007; IN COMMERCE 9-22-2007.
RENEE SERVANCE, EXAMINING ATTORNEY

SN 85-116,124. KOHR BROTHERS, INC., CHARLOTTESVILLE, VA. FILED 8-26-2010.

SN 85-117,462. ARRIS GROUP, INC., SUWANEE, GA. FILED 8-27-2010.

FOUR BROS

THE MARK CONSISTS OF STANDARD CHARACTERS WITHOUT CLAIM TO ANY PARTICULAR FONT, STYLE, SIZE, OR COLOR.

CLASS 30—STAPLE FOODS

FOR FROZEN DESSERTS, FROZEN CUSTARD, FRUIT SORBET, ICE CREAM, ICE MILK AND FROZEN YOGURT, AND MILKSHAKES (U.S. CL. 46).

CLASS 43—HOTEL AND RESTAURANT SERVICES

FOR SERVING OF FOOD AND DRINK/BEVERAGES, NAMELY, SERVING OF FROZEN DESSERTS, ICE CREAM AND FROZEN CUSTARD, AND NOT INCLUDING RESTAURANT SERVICES (U.S. CLS. 100 AND 101).
JAY BESCH, EXAMINING ATTORNEY

SN 85-116,487. BNP MEDIA II, LLC, TROY, MI. FILED 8-26-2010.

FOOD AUTOMATION & MANUFACTURING FA&M CONFERENCE AND EXPO

THE MARK CONSISTS OF STANDARD CHARACTERS WITHOUT CLAIM TO ANY PARTICULAR FONT, STYLE, SIZE, OR COLOR.

OWNER OF U.S. REG. NO. 2,365,473.

NO CLAIM IS MADE TO THE EXCLUSIVE RIGHT TO USE "FOOD AUTOMATION & MANUFACTURING" AND "CONFERENCE AND EXPO", APART FROM THE MARK AS SHOWN.

CLASS 35—ADVERTISING AND BUSINESS

FOR ARRANGING AND CONDUCTING BUSINESS CONFERENCES (U.S. CLS. 100, 101 AND 102).
FIRST USE 1-0-2003; IN COMMERCE 1-0-2003.

CLASS 41—EDUCATION AND ENTERTAINMENT

FOR ARRANGING AND CONDUCTING EDUCATIONAL CONFERENCES IN THE FIELDS OF FOOD AUTOMATION, MANUFACTURING, SUSTAINABILITY, AND SAFETY (U.S. CLS. 100, 101 AND 107).
FIRST USE 1-0-2003; IN COMMERCE 1-0-2003.
MICHELLE DUBOIS, EXAMINING ATTORNEY



OWNER OF U.S. REG. NOS. 2,841,375 AND 2,971,140.
THE MARK CONSISTS OF THE GRAPHIC SYMBOL OF AN AIRPLANE WITH THE NAME "ARRIS" UNDERNEATH THE IMAGE, WHICH IS THE LOGO OF THE ARRIS GROUP, INC.

CLASS 9—ELECTRICAL AND SCIENTIFIC APPARATUS

FOR COMMUNICATIONS SYSTEMS EQUIPMENT, NAMELY, OPTICAL TRANSMITTERS, OPTICAL RECEIVERS, OPTICAL NODES, OPTICAL AMPLIFIERS, RF AMPLIFIERS, OPTICAL COUPLERS, TAPS FOR USE IN OPTICAL FIBER OR HYBRID COAXIAL FIBER NETWORK COMMUNICATION, LINE PASSIVES FOR USE IN OPTICAL FIBER OR HYBRID COAXIAL FIBER NETWORK COMMUNICATION, SPLITTERS FOR USE IN OPTICAL FIBER OR HYBRID COAXIAL FIBER NETWORK COMMUNICATION, COUPLERS FOR USE IN OPTICAL FIBER OR HYBRID COAXIAL FIBER NETWORK COMMUNICATION, AND CONNECTORS FOR USE IN OPTICAL FIBER OR HYBRID COAXIAL FIBER NETWORK COMMUNICATION, FOR VOICE, DATA, AND VIDEO UTILIZED IN THE CABLE TELEVISION, TELEPHONE, AND POWER INDUSTRIES (U.S. CLS. 21, 23, 26, 36 AND 38).
FIRST USE 8-14-2003; IN COMMERCE 8-14-2003.

CLASS 42—SCIENTIFIC AND COMPUTER SERVICES

FOR COMPUTER SOFTWARE AND HARDWARE DESIGN, ENGINEERING, AND PRODUCT DEVELOPMENT IN THE FIELD OF TELEPHONY, CABLE TELEVISION, WIRELESS COMMUNICATION, BROADBAND AND OPTICAL FIBER NETWORKS; TECHNOLOGY CONSULTATION IN THE FIELD OF TELECOMMUNICATIONS (U.S. CLS. 100 AND 101).
FIRST USE 8-14-2003; IN COMMERCE 8-14-2003.
APRIL ROACH, EXAMINING ATTORNEY

SN 85-117,633. COHEN, CYNTHIA, AVENTURA, FL. FILED 8-27-2010.

THELUNCHGIRLS

THE MARK CONSISTS OF STANDARD CHARACTERS WITHOUT CLAIM TO ANY PARTICULAR FONT, STYLE, SIZE, OR COLOR.

CLASS 35—ADVERTISING AND BUSINESS

FOR ONLINE SERVICE FOR CONNECTING SOCIAL NETWORK USERS WITH RETAILERS FOR THE PURPOSE OF FACILITATING PURCHASES; PROMOTING THE GOODS AND SERVICES OF OTHERS BY PROVIDING A WEB SITE FEATURING LINKS TO THE RETAIL WEB SITES OF OTHERS, AND DISCOUNT INFORMATION (U.S. CLS. 100, 101 AND 102).

CLASS 38—COMMUNICATION

FOR PROVIDING ON-LINE CHAT ROOMS FOR SOCIAL NETWORKING; AND WEB CASTING SERVICES (U.S. CLS. 100, 101 AND 104).

CLASS 41—EDUCATION AND ENTERTAINMENT

FOR ENTERTAINMENT AND EDUCATIONAL SERVICES, NAMELY, ONGOING TELEVISION AND RADIO TALK SHOWS IN THE FIELD OF LIFESTYLE ISSUES (U.S. CLS. 100, 101 AND 107).

CLASS 42—SCIENTIFIC AND COMPUTER SERVICES

FOR HOSTING AN ON-LINE COMMUNITY WEB SITE FEATURING USER DISCUSSIONS, PEER FEEDBACK, VIRTUAL COMMUNITIES, AND SOCIAL NETWORKING FEATURING SOCIAL MEDIA AND TOPICS ON LIFESTYLE ISSUES (U.S. CLS. 100 AND 101).

KATHERINE STOIDES, EXAMINING ATTORNEY

SN 85-117,771. EVENTIS MEDIA LLC, ROYAL OAK, MI. FILED 8-27-2010.

EVENTIS

THE MARK CONSISTS OF STANDARD CHARACTERS WITHOUT CLAIM TO ANY PARTICULAR FONT, STYLE, SIZE, OR COLOR.

CLASS 9—ELECTRICAL AND SCIENTIFIC APPARATUS

FOR ELECTRONIC DEVICE FOR COPYING, DISPLAYING AND TRANSFERRING PHOTOGRAPHS AND VIDEOS FROM DIGITAL DEVICES, AND FOR UPLOADING PHOTOGRAPHS AND VIDEOS TO THE INTERNET FOR OTHERS; RENTAL OF COMPUTER HARDWARE TO COPY, DISPLAY AND TRANSFER PHOTOGRAPHS AND VIDEOS FROM DIGITAL DEVICES, AND UPLOAD PHOTOGRAPHS AND VIDEOS TO THE INTERNET (U.S. CLS. 21, 23, 26, 36 AND 38).

CLASS 42—SCIENTIFIC AND COMPUTER SERVICES

FOR DIGITAL TRANSFER SERVICES FOR COPYING, DISPLAYING AND TRANSFERRING PHOTOGRAPHS AND VIDEOS FROM DIGITAL DEVICES, AND UPLOADING PHOTOGRAPHS AND VIDEOS TO THE INTERNET FOR OTHERS; RENTAL OF COMPUTER HARDWARE TO COPY, DISPLAY AND TRANSFER PHOTOGRAPHS AND VIDEOS FROM DIGITAL DEVICES, AND UPLOAD PHOTOGRAPHS AND VIDEOS TO THE INTERNET (U.S. CLS. 100 AND 101).

JOSETTE BEVERLY, EXAMINING ATTORNEY

SN 85-117,942. BUBBLEDECK NORTH AMERICA, LLC, KIRKLAND, WA. FILED 8-27-2010.

BUBBLEDECK

THE MARK CONSISTS OF STANDARD CHARACTERS WITHOUT CLAIM TO ANY PARTICULAR FONT, STYLE, SIZE, OR COLOR.

CLASS 19—NON-METALLIC BUILDING MATERIALS

FOR CONCRETE SLABS; CONCRETE SLABS CONTAINING HOLLOW PLASTIC BALLS; BUILDING MATERIALS, NAMELY, COMPOSITE PANELS AND SLABS COMPOSED PRIMARILY OF NONMETAL MATERIALS (U.S. CLS. 1, 12, 33 AND 50).

CLASS 37—CONSTRUCTION AND REPAIR

FOR INSTALLATION AND CONSTRUCTION SUPERVISION OF INSTALLATION OF CONCRETE SLAB AND BUILDING MATERIALS (U.S. CLS. 100, 103 AND 106).

WARREN L. OLANDRIA, EXAMINING ATTORNEY

SN 85-117,974. BOB LAKE, LLC, SAINT PAUL, MN. FILED 8-27-2010.



NO CLAIM IS MADE TO THE EXCLUSIVE RIGHT TO USE "OIL" AS TO CLASS 03 AND "CONTROL", APART FROM THE MARK AS SHOWN.

THE STIPPLING IS FOR SHADING PURPOSES ONLY.

THE NAME "BOB LAKE" DOES NOT IDENTIFY A LIVING INDIVIDUAL.

THE MARK CONSISTS OF THE STYLIZED DEPICTION OF A WOMAN HOLDING THE STRAPS OF HER BIKINI WITH THE STYLIZED TERM "BOB" ON LEFT OF THE WOMAN'S HEAD, WHERE THE LETTER "O" IS REPRESENTED BY A FISHING BOBBER AND WITH THE STYLIZED TERM "LAKE" TO THE RIGHT OF THE WOMAN'S HEAD, WITH THE TERM "MILFOIL" TO THE RIGHT OF THE WOMAN UNDER THE TERM "LAKE", WHERE THE "MILF" PORTION APPEARS IN LARGE LETTERS AND THE "OIL" PORTION APPEARS IN SMALL LETTERS, ABOVE THE STYLIZED PHRASE "CONTROL IT!", WITH A SMALL CONICAL SHRUB TO THE LEFT OF THE WOMAN, PARTIALLY COVERING HER BOTTOM LEFT SIDE AND WITH A STYLIZED CURVED BAND REPRESENTING A RIPPLE IN A LAKE BENEATH THE WOMAN.

THE WORDING "MILFOIL" HAS NO MEANING IN A FOREIGN LANGUAGE.

CLASS 3—COSMETICS AND CLEANING PREPARATIONS

FOR BATH GELS; BEAUTY CREAMS; COSMETIC SUNTAN LOTIONS; LOTIONS FOR SKIN, FACE, AND BODY; MASSAGE OILS; SUN SCREEN (U.S. CLS. 1, 4, 6, 50, 51 AND 52).

FIRST USE 3-1-2010; IN COMMERCE 3-1-2010.

CLASS 25—CLOTHING

FOR CAPS; HATS; JACKETS; SHORTS; SWEAT SHIRTS; T-SHIRTS (U.S. CLS. 22 AND 39).

FIRST USE 3-1-2010; IN COMMERCE 3-1-2010.
MYRIAH HABEEB, EXAMINING ATTORNEY

SN 85-119,855. GAIAM AMERICAS, INC., LOUISVILLE, CO.
FILED 8-31-2010.



THE MARK CONSISTS OF A STYLIZED FIGURE OF A SIX-PETALED FLOWER INSIDE A CIRCLE.

SN 85-118,977. HENDRICKSON USA, LLC, ITASCA, IL.
FILED 8-30-2010.

AERO GUARD

THE MARK CONSISTS OF STANDARD CHARACTERS WITHOUT CLAIM TO ANY PARTICULAR FONT, STYLE, SIZE, OR COLOR.

CLASS 12—VEHICLES

FOR VEHICLE GRILL SURROUNDS, VEHICLE HEADLIGHT BEZELS, VEHICLE BUMPERS, VEHICLE FAIRINGS, VEHICLE FENDERS, VEHICLE DEFLECTORS, VEHICLE BUG SHIELDS, VEHICLE DASHBOARD BEZELS, VEHICLE INTERIOR TRIM COMPONENTS FOR USE WITH TRUCKS, TRACTORS, BUSES AND TRAILERS (U.S. CLS. 19, 21, 23, 31, 35 AND 44).

CLASS 40—MATERIAL TREATMENT

FOR PARTS MOLDING, NAMELY, THE CUSTOM MANUFACTURE OF THERMO-PLASTIC, INJECTION-MOLDED COMPONENTS WITH INTEGRAL STRUCTURES AND A CLASS A SURFACE FINISH FOR USE WITH TRUCKS, TRACTORS, BUSES AND TRAILERS (U.S. CLS. 100, 103 AND 106).

PRISCILLA MILTON, EXAMINING ATTORNEY

CLASS 9—ELECTRICAL AND SCIENTIFIC APPARATUS

FOR (BASED ON USE IN COMMERCE) DIGITAL MEDIA, NAMELY, PRE-RECORDED COMPACT DISCS, DVDS, HIGH DEFINITION DIGITAL DISCS, AND DOWNLOADABLE AUDIO AND AUDIO-VISUAL RECORDINGS, ALL IN THE FIELD OF EXERCISE, FITNESS, WELLNESS AND PERSONAL DEVELOPMENT; PEDOMETERS (U.S. CLS. 21, 23, 26, 36 AND 38).

FIRST USE 11-30-2001; IN COMMERCE 11-30-2001.

CLASS 18—LEATHER GOODS

FOR (BASED ON INTENT TO USE) GENERAL PURPOSE BAGS FOR CARRYING YOGA EQUIPMENT (U.S. CLS. 1, 2, 3, 22 AND 41).

CLASS 21—HOUSEWARES AND GLASS

FOR (BASED ON USE IN COMMERCE) ALUMINUM WATER BOTTLES SOLD EMPTY (U.S. CLS. 2, 13, 23, 29, 30, 33, 40 AND 50).

FIRST USE 4-1-2008; IN COMMERCE 4-1-2008.

CLASS 24—FABRICS

FOR (BASED ON USE IN COMMERCE) BATH LINENS AND BED LINENS; YOGA TOWELS (U.S. CLS. 42 AND 50).

FIRST USE 12-31-2002; IN COMMERCE 12-31-2002.

CLASS 25—CLOTHING

FOR (BASED ON USE IN COMMERCE) CLOTHING, NAMELY, DRESSES, SHIRTS, TANK TOPS, T-SHIRTS, SHORTS, PANTS, SWEATERS, SKIRTS, SWEATSHIRTS, PAJAMAS, UNDERWEAR, BRAS, SOCKS, ROBES AND HATS; YOGA SOCKS (U.S. CLS. 22 AND 39).

FIRST USE 12-31-2002; IN COMMERCE 12-31-2002.

CLASS 28—TOYS AND SPORTING GOODS

FOR (BASED ON USE IN COMMERCE) EXERCISE AND FITNESS EQUIPMENT, NAMELY, STABILITY BALLS, MEDICINE BALLS, BALANCE DISKS, RESISTANCE BANDS, RESISTANCE CORDS, YOGA STRAPS, YOGA BRICKS, YOGA MATS, YOGA BALLS, YOGA GLOVES, PILATES MATS, STEP PLATFORMS, FOAM ROLLERS, HAND WEIGHTS, KETTLE BELLS AND WEIGHTED BARS (U.S. CLS. 22, 23, 38 AND 50).

FIRST USE 12-31-2002; IN COMMERCE 12-31-2002.

CLASS 35—ADVERTISING AND BUSINESS

FOR (BASED ON USE IN COMMERCE) MAIL ORDER CATALOG SERVICES IN THE FIELDS OF ENVIRONMENTALLY SENSITIVE PRODUCTS, NAMELY, BIODEGRADABLE HOUSEHOLD CLEANERS, LAUNDRY POWDER, LAUNDRY LIQUID, FABRIC SOFTENER, DISH LIQUID, DISHWASHER DETERGENT, BATH TISSUE, PAPER TOWELS, PAPER NAPKINS, FACIAL TISSUES, BABY WIPES, PLASTIC TRASH BAGS, TOILET BOWL CLEANER, SHEETS, QUILTS, TOWELS, SHOWER CURTAINS, BATH MATS, TOWEL RACKS, SHOWER AND FAUCET FILTERS, PANTS, TOPS, T-SHIRTS, SHORTS, SWEATERS, AND SOCKS MADE OF ORGANIC COTTON, COMPOSTERS, COMPOSTING CROCKS, COMPOST BUCKETS, RECYCLING BAGS, SOLAR-POWERED COOKERS, ADDRESS LIGHTS, FOOD DEHYDRATORS, AND WEATHER STATIONS, ENERGY EFFICIENT AIR CONDITIONERS, HEATERS, AND WINDOW SHADES, SPIRITUAL, METAPHYSICAL AND PHILOSOPHICAL PRODUCTS, NAMELY, DVDS ON THE SUBJECT OF MEDITATION, RELIGIOUS EXPLORATION, AND KNOWLEDGE, SCIENTIFIC PRODUCTS, NAMELY, DVDS ON THE SUBJECT OF CHAOS THEORY, CREATION, PLANET ECOLOGY, QUANTUM THEORY, GLOBAL WARMING, MATHEMATIC THEORY AND BIOLOGY, AND SELF-HELP PRODUCTS, NAMELY, DVDS AND BOOKS ON THE SUBJECT OF FITNESS, PERSONAL DEVELOPMENT, MENTAL AND EMOTIONAL HEALTH ISSUES, AND PHYSICAL AILMENTS (U.S. CLS. 100, 101 AND 102).
FIRST USE 6-30-2000; IN COMMERCE 6-30-2000.

CLASS 38—COMMUNICATION

FOR (BASED ON USE IN COMMERCE) STREAMING OF PRE-RECORDED AUDIO AND AUDIO-VISUAL RECORDINGS VIA A GLOBAL COMPUTER NETWORK (U.S. CLS. 100, 101 AND 104).
FIRST USE 11-30-2006; IN COMMERCE 11-30-2006.
ASMAT KHAN, EXAMINING ATTORNEY

SN 85-120,125. ABUNDA FUNCTIONAL FOODS, INC., SANDY, UT. FILED 8-31-2010.

MOJOMILK

THE MARK CONSISTS OF STANDARD CHARACTERS WITHOUT CLAIM TO ANY PARTICULAR FONT, STYLE, SIZE, OR COLOR.

CLASS 29—MEATS AND PROCESSED FOODS

FOR FLAVORED MILK, MILK AND MILK BASED BEVERAGES AND CHOCOLATE MILK (U.S. CL. 46).

CLASS 30—STAPLE FOODS

FOR CHOCOLATE FLAVORINGS FOR USE IN MILK BASED BEVERAGES (U.S. CL. 46).
FIRST USE 5-17-2010; IN COMMERCE 8-10-2010.
NELSON SNYDER, EXAMINING ATTORNEY

SN 85-120,954. ACI GLASS PRODUCTS, LLC, MEMPHIS, TN. FILED 9-1-2010.

SOUND SAFE

THE MARK CONSISTS OF STANDARD CHARACTERS WITHOUT CLAIM TO ANY PARTICULAR FONT, STYLE, SIZE, OR COLOR.

CLASS 6—METAL GOODS

FOR BUILDING MATERIALS, NAMELY, METAL FRAMEWORKS FOR ARCHITECTURAL ALUMINUM ENTRANCES AND STOREFRONTS; FRAMEWORKS OF METAL; METAL CURTAIN WALLS (U.S. CLS. 2, 12, 13, 14, 23, 25 AND 50).

CLASS 19—NON-METALLIC BUILDING MATERIALS

FOR BUILDING MATERIALS AND ARCHITECTURAL PRODUCTS, NAMELY, COMMON SHEET GLASS, LAMINATED FLAT GLASS, WIRE GLASS, NAMELY, A SAFETY GLASS WITH REINFORCING METAL WIRE, INSULATED GLASS, HEAT-TREATED GLASS, NON-METAL SPANDREL, GLASS HANDRAILS AND GLASS DOORS (U.S. CLS. 1, 12, 33 AND 50).

CLASS 35—ADVERTISING AND BUSINESS

FOR DISTRIBUTORSHIP SERVICES IN THE FIELD OF GLASS, METAL AND NON-METAL GLASS-RELATED PRODUCTS AND METAL AND NON-METAL ARCHITECTURAL PRODUCTS (U.S. CLS. 100, 101 AND 102).

CLASS 37—CONSTRUCTION AND REPAIR

FOR INSTALLATION OF CUSTOM SKYLIGHT SYSTEMS, COMMERCIAL AND RESIDENTIAL GLASS PRODUCTS AND AUTO GLASS (U.S. CLS. 100, 103 AND 106).
KATHLEEN M. VANSTON, EXAMINING ATTORNEY

SN 85-121,062. BOARD OF TRUSTEES FOR THE NEBRASKA STATE COLLEGES, DBA WAYNE STATE COLLEGE, LINCOLN, NE. FILED 9-1-2010.



THE COLOR(S) BLACK, WHITE AND GOLD IS/ARE CLAIMED AS A FEATURE OF THE MARK.

THE MARK CONSISTS OF THE LITERAL ELEMENT OF "WSC", WHICH APPEARS IN WHITE AND IS UNDERLINED IN WHITE, AND BOTH THE LITERAL ELEMENT AND UNDERLINING ARE SUPERIMPOSED OVER A PAW OF A WILDCAT, WITH THE PADS OF THE PAW APPEARING IN BLACK, OUTLINED IN GOLD, AND THEN OUTLINED AGAIN IN BLACK.

SN 85-121,077. BOARD OF TRUSTEES FOR THE NEBRASKA STATE COLLEGES, DBA WAYNE STATE COLLEGE, LINCOLN, NE. FILED 9-1-2010.



CLASS 25—CLOTHING

FOR CLOTHING, NAMELY, ATHLETIC UNIFORMS, SHIRTS, T-SHIRTS, SWEATSHIRTS, SHORTS, PANTS, VESTS, JERSEYS, LOUNGEWEAR, SLEEPWEAR, AND INFANT AND TODDLER ONE-PIECE CLOTHING GARMENTS ALL PROMOTING WAYNE STATE COLLEGE; SOCKS PROMOTING WAYNE STATE COLLEGE; HATS PROMOTING WAYNE STATE COLLEGE; CAPS PROMOTING WAYNE STATE COLLEGE; APRONS PROMOTING WAYNE STATE COLLEGE; JACKETS PROMOTING WAYNE STATE COLLEGE; PARKAS PROMOTING WAYNE STATE COLLEGE; COATS PROMOTING WAYNE STATE COLLEGE (U.S. CLS. 22 AND 39).
FIRST USE 0-0-1998; IN COMMERCE 0-0-1998.

THE MARK CONSISTS OF AN UNDERLINED LITERAL ELEMENT OF "WSC" SUPERIMPOSED OVER A PAW OF A WILDCAT WITH THE PADS OF THE PAW APPEARING IN BLACK, OUTLINED IN WHITE AND THEN OUTLINED AGAIN IN BLACK.

CLASS 25—CLOTHING

FOR CLOTHING, NAMELY, ATHLETIC UNIFORMS, SHIRTS, T-SHIRTS, SWEATSHIRTS, SHORTS, PANTS, VESTS, JERSEYS, LOUNGEWEAR, SLEEPWEAR, AND INFANT AND TODDLER ONE-PIECE CLOTHING GARMENTS ALL PROMOTING WAYNE STATE COLLEGE; SOCKS PROMOTING WAYNE STATE COLLEGE; HATS PROMOTING WAYNE STATE COLLEGE; CAPS PROMOTING WAYNE STATE COLLEGE; APRONS PROMOTING WAYNE STATE COLLEGE; JACKETS PROMOTING WAYNE STATE COLLEGE; PARKAS PROMOTING WAYNE STATE COLLEGE; COATS PROMOTING WAYNE STATE COLLEGE (U.S. CLS. 22 AND 39).
FIRST USE 0-0-1998; IN COMMERCE 0-0-1998.

CLASS 41—EDUCATION AND ENTERTAINMENT

FOR EDUCATION AND ENTERTAINMENT SERVICES, NAMELY, PROVIDING COURSES OF INSTRUCTION AT THE COLLEGE LEVEL; RESEARCH IN THE FIELD OF EDUCATION AT THE COLLEGE LEVEL; ARRANGING AND CONDUCTING ATHLETIC EVENTS AND TOURNAMENTS AT THE COLLEGE LEVEL; COLLEGE EDUCATIONAL SERVICES, NAMELY, PROVIDING EXHIBITS IN THE FIELD OF PHYSICAL SCIENCES AND VISUAL ARTS; ARRANGING AND CONDUCTING COLLEGE EDUCATIONAL CONFERENCES; LIVE PERFORMANCES AND FESTIVALS IN CONNECTION WITH A COLLEGE, NAMELY, MUSICAL PERFORMANCES AND CONCERTS, THEATRICAL PRODUCTIONS, DANCE PRODUCTIONS, ACADEMIC COMPETITIONS, INTERNATIONAL CULTURAL DINERS FEATURING CUISINE AND ENTERTAINMENT FROM CULTURES OF CURRENT STUDENTS FROM OTHER COUNTRIES AND THE UNITED STATES, LECTURES IN THE FIELD OF ARTS AND HUMANITIES, BUSINESS AND TECHNOLOGY AND EDUCATION AND COUNSELING; ENTERTAINMENT IN THE NATURE OF SCIENCE FICTION AND FANTASY CONVENTIONS AND LANGUAGE ARTS FESTIVALS; ATHLETIC EVENTS IN THE NATURE OF BASEBALL, BASKETBALL, FOOTBALL, SOFTBALL AND VOLLEYBALL GAMES AND TRACK, CROSS COUNTRY AND GOLF MEETS, SOCCER AND RUGBY MATCHES; GOLF, SOFTBALL, BASKETBALL AND BASEBALL TOURNAMENTS; ENTERTAINMENT EXHIBITIONS IN THE NATURE OF HEALTH AND WELLNESS FAIRS AND EDUCATIONAL DEMONSTRATIONS IN THE FIELD OF PHYSICAL SCIENCES (U.S. CLS. 100, 101 AND 107).
FIRST USE 0-0-1998; IN COMMERCE 0-0-1998.
JOHN GARTNER, EXAMINING ATTORNEY

CLASS 41—EDUCATION AND ENTERTAINMENT

FOR EDUCATION AND ENTERTAINMENT SERVICES, NAMELY, PROVIDING COURSES OF INSTRUCTION AT THE COLLEGE LEVEL; RESEARCH IN THE FIELD OF EDUCATION AT THE COLLEGE LEVEL; ARRANGING AND CONDUCTING ATHLETIC EVENTS AND TOURNAMENTS AT THE COLLEGE LEVEL; COLLEGE EDUCATIONAL SERVICES, NAMELY, PROVIDING EXHIBITS IN THE FIELD OF PHYSICAL SCIENCES AND VISUAL ARTS; ARRANGING AND CONDUCTING COLLEGE EDUCATIONAL CONFERENCES; LIVE PERFORMANCES AND FESTIVALS IN CONNECTION WITH A COLLEGE, NAMELY, MUSICAL PERFORMANCES AND CONCERTS, THEATRICAL PRODUCTIONS, DANCE PRODUCTIONS, ACADEMIC COMPETITIONS, INTERNATIONAL CULTURAL DINERS FEATURING CUISINE AND ENTERTAINMENT FROM CULTURES OF CURRENT STUDENTS FROM OTHER COUNTRIES AND THE UNITED STATES, LECTURES IN THE FIELD OF ARTS AND HUMANITIES, BUSINESS AND TECHNOLOGY AND EDUCATION AND COUNSELING; ENTERTAINMENT IN THE NATURE OF SCIENCE FICTION AND FANTASY CONVENTIONS AND LANGUAGE ARTS FESTIVALS; ATHLETIC EVENTS IN THE NATURE OF BASEBALL, BASKETBALL, FOOTBALL, SOFTBALL AND VOLLEYBALL GAMES AND TRACK, CROSS COUNTRY AND GOLF MEETS, SOCCER AND RUGBY MATCHES; GOLF, SOFTBALL, BASKETBALL AND BASEBALL TOURNAMENTS; ENTERTAINMENT EXHIBITIONS IN THE NATURE OF HEALTH AND WELLNESS FAIRS AND EDUCATIONAL DEMONSTRATIONS IN THE FIELD OF PHYSICAL SCIENCES (U.S. CLS. 100, 101 AND 107).
FIRST USE 0-0-1998; IN COMMERCE 0-0-1998.
JOHN GARTNER, EXAMINING ATTORNEY

SN 85-121,151. SERVICE PROVIDER GROUP LLC, KNOXVILLE, TN. FILED 9-1-2010.



NO CLAIM IS MADE TO THE EXCLUSIVE RIGHT TO USE "SERVICE PROVIDER GROUP", APART FROM THE MARK AS SHOWN.

THE MARK CONSISTS OF THREE CONNECTED PUZZLE PIECES WITH A SEMI-DETACHED PUZZLE PIECE CONTAINING THE LETTERS "SPG" CENTERED ABOVE THE WORDS "SERVICE PROVIDER GROUP" IN A SPECIALIZED LARGER FONT; THE "S" "P" AND "G" ARE ALL CAPITALIZED WHILE THE REMAINDER OF THE WORDS ARE LOWER-CASE. BELOW "SERVICE PROVIDER GROUP" THE FOLLOWING IS WRITTEN IN A SMALLER FONT: "WHERE ALL THE PIECES OF YOUR BUSINESS COME TOGETHER".

CLASS 9—ELECTRICAL AND SCIENTIFIC APPARATUS

FOR COMPUTER SOFTWARE THAT PROVIDES REAL-TIME, INTEGRATED BUSINESS MANAGEMENT INTELLIGENCE BY COMBINING INFORMATION FROM VARIOUS DATABASES AND PRESENTING IT IN AN EASY-TO-UNDERSTAND USER INTERFACE; DOWNLOADABLE AUDIO FILES, MULTIMEDIA FILES, TEXT FILES, E-MAILS, WRITTEN DOCUMENTS, AUDIO MATERIAL, VIDEO MATERIAL AND GAMES FEATURING INFORMATION IN THE FORM OF DOWNLOADABLE SHORT EDUCATIONAL/TRAINING COMMUNICATIONS IN THE FIELD OF HUMAN RESOURCE DEVELOPMENT FOR THE PROMOTION OF EMPLOYEE RETENTION, CAREER GROWTH AND INCREASED PRODUCTIVITY FOR EMPLOYEES AND EMPLOYERS (U.S. CLS. 21, 23, 26, 36 AND 38).

CLASS 35—ADVERTISING AND BUSINESS

FOR ADMINISTRATION OF BUSINESS PAYROLL FOR OTHERS; BUSINESS MANAGEMENT CONSULTATION AND SERVICES, NAMELY, MANAGING AND ADMINISTERING NON-CORE FUNCTIONS, NAMELY, MAILING AND SHIPPING, RECORDS MANAGEMENT, INFORMATION SERVICES, ADMINISTRATION, PAYROLL AND ACCOUNTING, AND TELEMARKETING SERVICES; CONDUCTING EMPLOYEE SURVEYS FOR OTHERS FOR PURPOSES OF IMPROVING EMPLOYEE PERFORMANCE AND MORALE; CONSULTING SERVICES IN THE FIELD OF HUMAN RESOURCES DEVELOPMENT, NAMELY, FOR THE PROMOTION OF EMPLOYEE RETENTION, CAREER GROWTH, AND INCREASED PRODUCTIVITY FOR EMPLOYEES AND EMPLOYERS; CONSULTING SERVICES IN THE FIELD OF HUMAN RESOURCES DEVELOPMENT, NAMELY, UTILIZING TECHNOLOGY FOR THE PROMOTION OF EMPLOYEE RETENTION, CAREER GROWTH AND INCREASED PRODUCTIVITY FOR EMPLOYEES AND EMPLOYERS; CONSULTING SERVICES IN THE FIELDS OF BUSINESS MANAGEMENT, HUMAN RESOURCES, AND BUSINESS ORGANIZATIONAL DESIGN; DATA COMPILING AND ANALYZING IN THE FIELD OF INSURANCE; EMPLOYEE ADMINISTRATION SERVICES; EMPLOYEE LEASING; EMPLOYEE RELATIONS INFORMATION SERVICES; HUMAN RESOURCE ANALYSIS AND CONSULTING SERVICES; HUMAN RESOURCE SERVICES, NAMELY, COLLECTING, ANALYZING, REPORTING, AND PROVIDING FEEDBACK FROM INDIVIDUALS WHO SEPARATE FROM AN ORGANIZATION; HUMAN RESOURCE SERVICES, NAMELY, FACILITATING THE EMPLOYEE TERMINATION AND SEPARATION PROCESS BY EXECUTING THE REQUIRED ACTIVITY AND COMMUNICATION RELATED TO EMPLOYEE TERMINATION AND SEPARATION; HUMAN RESOURCES CONSULTANCY; HUMAN RESOURCES CONSULTATION; HUMAN RESOURCES MANAGEMENT; INSURANCE LEAD COL-

LECTION AND MATCHING SERVICES, NAMELY, MATCHING CONSUMER REQUESTS FOR INSURANCE POLICY QUOTES COLLECTED OVER THE INTERNET TO PRE-QUALIFIED INSURANCE BROKERS, AGENTS AND AGENCIES INTERESTED IN THOSE REQUESTS; INTERACTIVE RECORD-KEEPING SERVICES FOR USE IN RISK MANAGEMENT AND REGULATORY COMPLIANCE BY INSURERS AND PROFESSIONALS IN THE MEDICAL FIELD; MANAGING THE OPERATIONS OF INSURANCE AGENCIES AND BROKERS ON AN OUTSOURCING BASIS; PAYROLL ADMINISTRATION AND MANAGEMENT SERVICES; PAYROLL PREPARATION; PAYROLL PROCESSING SERVICES; PLACEMENT OF STAFF; PROFESSIONAL EMPLOYER ORGANIZATION SERVICES IN THE NATURE OF EMPLOYEE LEASING; PROMOTION OF FINANCIAL AND INSURANCE SERVICES, ON BEHALF OF THIRD PARTIES; PROVIDING A PRICING PROGRAM IN THE FIELD OF PROPERTY AND CASUALTY INSURANCE THROUGH WHICH MEMBERS OF DESIGNATED ASSOCIATIONS, ORGANIZATIONS, AND GROUPS MAY BE OFFERED OR GRANTED DOWNWARD ADJUSTMENTS IN THE PREMIUMS FOR SUCH INSURANCE; PROVIDING AN EMPLOYER WITH CANDIDATES OR POTENTIAL EMPLOYEES TO FILL TEMPORARY, CONTRACT AND PERMANENT POSITIONS; PROVIDING BUSINESS SUPPORT STAFF SERVICES; PROVIDING INSURANCE AGENT REFERRALS; PROVIDING SALES LEADS FOR THE AUTOMOTIVE FINANCE AND INSURANCE INDUSTRIES; PROVIDING STATISTICAL EVALUATION OF INSURANCE CLAIMS PERFORMANCE MEASURES FOR OTHERS; SERVING AS A HUMAN RESOURCES DEPARTMENT FOR OTHERS; TRACKING AND MONITORING INSURANCE COMPLIANCE; VALUE-ADDED RESELLER SERVICES, NAMELY, DISTRIBUTORSHIP SERVICES FEATURING COMPUTER SECURITY AND INFORMATION TECHNOLOGY PRODUCTS; WAGE PAYROLL PREPARATION (U.S. CLS. 100, 101 AND 102).

CLASS 36—INSURANCE AND FINANCIAL

FOR ACCIDENT INSURANCE UNDERWRITING; ADMINISTRATION OF EMPLOYEE BENEFIT PLANS CONCERNING INSURANCE AND FINANCE; ADMINISTRATION OF EMPLOYEE WELFARE BENEFIT PLANS CONCERNING INSURANCE AND FINANCE; ADVISORY SERVICES IN THE FIELD OF EMPLOYEE BENEFITS FOR GROUP HEALTHCARE AND BUSINESS INSURANCE OFFERED TO EMPLOYEES IN ADDITION TO STANDARD BENEFITS SUCH AS MEDICAL, DENTAL, LIFE INSURANCE INCLUDING SHORT TERM DISABILITY, LONG TERM DISABILITY, CANCER INSURANCE, ACCIDENTAL DEATH AND DISMEMBERMENT; APPRAISALS FOR INSURANCE CLAIMS OF PERSONAL PROPERTY; APPRAISALS FOR INSURANCE CLAIMS OF REAL ESTATE; BROKERAGE IN THE FIELD OF PROPERTY, CASUALTY, HEALTH, AND LIFE INSURANCE; CLAIMS ADMINISTRATION SERVICES IN THE FIELD OF HEALTH INSURANCE; CONSULTING AND INFORMATION CONCERNING INSURANCE; CONSULTING SERVICES IN THE FIELD OF STATE AND FEDERAL EMPLOYEE BENEFIT PLANS CONCERNING INSURANCE AND FINANCE; DENTAL HEALTH INSURANCE ADMINISTRATION; DENTAL HEALTH INSURANCE UNDERWRITING AND ADMINISTRATION; ELECTRONIC PROCESSING OF INSURANCE CLAIMS AND PAYMENT DATA; FINANCIAL CONSULTANCY AND INSURANCE CONSULTANCY; FINANCIAL EVALUATION FOR INSURANCE PURPOSES; INSURANCE ADMINISTRATION; INSURANCE ADMINISTRATION IN THE FIELD OF PROPERTY, CASUALTY, HEALTH AND LIFE; INSURANCE ADMINISTRATION SERVICES, NAMELY, ASSISTING OTHERS WITH ADJUSTING INSURANCE CLAIMS; INSURANCE ADMINISTRATION SERVICES, NAMELY, ASSISTING OTHERS WITH COLLECTING INSURANCE PREMIUMS; INSURANCE AGENCIES; INSURANCE AGENCIES IN THE FIELD OF PROPERTY, CASUALTY, HEALTH AND LIFE; INSURANCE AGENCY AND BROKERAGE; INSURANCE AND FINANCIAL INFORMATION AND CONSULTANCY SERVICES; INSURANCE BROKERAGE; INSURANCE BROKERAGE IN THE FIELD OF PROPERTY, CASUALTY, HEALTH AND LIFE; INSURANCE CLAIMS ADMINISTRATION; INSURANCE CLAIMS PROCESSING; INSURANCE CONSULTANCY; INSURANCE CONSULTANCY SERVICES, NAMELY, PROVIDING ADVICE IN THE FIELD OF PROPERTY AND

CASUALTY INSURANCE; INSURANCE CONSULTATION; INSURANCE INFORMATION; INSURANCE INFORMATION AND CONSULTANCY; INSURANCE PREMIUM RATE COMPUTING; INSURANCE SERVICES IN THE NATURE OF LOSS CONTROL MANAGEMENT FOR OTHERS; INSURANCE SERVICES, NAMELY, INSURANCE ELIGIBILITY REVIEW AND VERIFICATION AND CONSULTATION IN THE PROPERTY, CASUALTY, HEALTH AND LIFE INDUSTRY; INSURANCE SERVICES, NAMELY, PROVIDING INDEPENDENT SCORING SERVICE RELATED TO EXISTING MEDICAL SERVICES IN A SPECIFIC GEOGRAPHIC REGION FOR INSURANCE EVALUATION PURPOSES; INSURANCE SERVICES, NAMELY, WRITING PROPERTY AND CASUALTY INSURANCE; PAYROLL TAX DEBITING SERVICES; PROCESSING, ADMINISTERING AND MANAGING EMPLOYEE BENEFIT PLANS CONCERNING INSURANCE AND FINANCE; PROVIDING A DATABASE FOR TRACKING, MONITORING, AND GENERATING REPORTS ON INFORMATION AND STATISTICS ABOUT PATIENT REIMBURSEMENT AND INSURANCE COVERAGE FOR PHARMACEUTICALS AND MEDICAL DEVICES; PROVIDING INFORMATION IN INSURANCE MATTERS; PROVIDING INFORMATION REGARDING POLICY RATES FOR ALL TYPES OF INSURANCE AND ELECTRONIC PROCESSING OF INSURANCE CLAIMS AND PAYMENT DATA OVER A WEB BASED COMPUTER NETWORK; PROVIDING INFORMATION REGARDING WORKERS' COMPENSATION INSURANCE POLICY RATES; PROVIDING VEHICLE INSURANCE RATE QUOTES (U.S. CLS. 100, 101 AND 102).

CLASS 41—EDUCATION AND ENTERTAINMENT

FOR TEACHING AND TRAINING IN BUSINESS, INDUSTRY AND INFORMATION TECHNOLOGY (U.S. CLS. 100, 101 AND 107).

CLASS 42—SCIENTIFIC AND COMPUTER SERVICES

FOR COMPUTER SERVICES, NAMELY, ON-SITE MANAGEMENT OF THE INFORMATION TECHNOLOGY (IT) SYSTEMS; COMPUTER SERVICES, NAMELY, REMOTE AND ON-SITE MANAGEMENT OF THE INFORMATION TECHNOLOGY (IT) CLOUD COMPUTING SYSTEMS OF OTHERS; COMPUTER SERVICES, NAMELY, REMOTE AND ON-SITE MANAGEMENT OF THE INFORMATION TECHNOLOGY (IT) SYSTEMS OF OTHERS; COMPUTER SERVICES, NAMELY, REMOTE MANAGEMENT OF THE INFORMATION TECHNOLOGY (IT) SYSTEMS OF OTHERS; CONDUCTING WORKSITE SURVEYS TO DETERMINE IF WORKSITES MEET EMPLOYEE HEALTH CONDITION REQUIREMENTS AND STANDARDS; CONSULTING IN THE FIELD OF INFORMATION TECHNOLOGY; INFORMATION TECHNOLOGY CONSULTATION; PLANNING, DESIGN AND MANAGEMENT OF INFORMATION TECHNOLOGY SYSTEMS; PROVIDING A WEB SITE FEATURING TECHNOLOGY THAT ENABLES COMPANIES AND ORGANIZATIONS TO ADMINISTER AND MANAGE EMPLOYEE INCENTIVE AWARD PROGRAMS AND TO PROMOTE EMPLOYEE PRODUCTIVITY, PERFORMANCE, RECOGNITION AND MORALE (U.S. CLS. 100 AND 101).

CLASS 45—PERSONAL AND LEGAL SERVICES

FOR EMPLOYEE MISCONDUCT INVESTIGATION SERVICES; EMPLOYMENT BACKGROUND SCREENING, NAMELY, BACKGROUND SCREENING OF CURRENT EMPLOYEES OF OTHERS; LEGAL SERVICES, NAMELY, PROVIDING CUSTOMIZED INFORMATION, COUNSELING, ADVICE AND LITIGATION SERVICES IN ALL AREAS OF EMPLOYMENT AND LABOR LAW FOR BOTH EMPLOYEES AND EMPLOYERS (U.S. CLS. 100 AND 101).

ELLEN BURNS, EXAMINING ATTORNEY

SN 85-121,548. ARASH HAZER, DBA ORIGIN5, DUNN LORING, VA. FILED 9-2-2010.

Origin5

THE MARK CONSISTS OF STANDARD CHARACTERS WITHOUT CLAIM TO ANY PARTICULAR FONT, STYLE, SIZE, OR COLOR.

CLASS 35—ADVERTISING AND BUSINESS

FOR BUSINESS MANAGEMENT CONSULTANCY AND ADVISORY SERVICES (U.S. CLS. 100, 101 AND 102).

FIRST USE 7-6-2008; IN COMMERCE 1-4-2009.

CLASS 42—SCIENTIFIC AND COMPUTER SERVICES

FOR TECHNICAL SUPPORT SERVICES, NAMELY, TECHNICAL ADVICE RELATED TO THE INSTALLATION OF SOFTWARE (U.S. CLS. 100 AND 101).

FIRST USE 7-6-2008; IN COMMERCE 1-4-2009.

BRIAN NEVILLE, EXAMINING ATTORNEY

SN 85-121,611. UNITED POS SOLUTIONS, INC., DBA UP SOLUTION, HACKENSACK, NJ. FILED 9-2-2010.

UP SOLUTION

THE MARK CONSISTS OF STANDARD CHARACTERS WITHOUT CLAIM TO ANY PARTICULAR FONT, STYLE, SIZE, OR COLOR.

NO CLAIM IS MADE TO THE EXCLUSIVE RIGHT TO USE "SOLUTION", APART FROM THE MARK AS SHOWN.

CLASS 35—ADVERTISING AND BUSINESS

FOR WHOLESALE AND RETAIL STORE SERVICES IN THE FIELD OF ELECTRONIC PAYMENT PROCESSING HARDWARE AND SOFTWARE EQUIPMENT (U.S. CLS. 100, 101 AND 102).

FIRST USE 10-1-2008; IN COMMERCE 10-1-2008.

CLASS 37—CONSTRUCTION AND REPAIR

FOR REPAIR AND MAINTENANCE OF ELECTRONIC PAYMENT PROCESSING HARDWARE EQUIPMENT (U.S. CLS. 100, 103 AND 106).

FIRST USE 10-1-2008; IN COMMERCE 10-1-2008.

CLASS 42—SCIENTIFIC AND COMPUTER SERVICES

FOR REPAIR AND MAINTENANCE OF ELECTRONIC PAYMENT SOFTWARE EQUIPMENT; APPLICATION SERVICE PROVIDER, NAMELY, PROVIDING, HOSTING, MANAGING, DEVELOPING, AND MAINTAINING APPLICATIONS, SOFTWARE, WEB SITES AND DATABASES IN THE FIELD OF CUSTOMER INFORMATION (U.S. CLS. 100 AND 101).

FIRST USE 10-1-2008; IN COMMERCE 10-1-2008.

PAUL E. FAHRENKOPF, EXAMINING ATTORNEY

SN 85-121,860. SURGERY THEATER, INC., DBA SURGERY THEATER, LOS ANGELES, CA. FILED 9-2-2010.



NO CLAIM IS MADE TO THE EXCLUSIVE RIGHT TO USE "SURGERY THEATER", APART FROM THE MARK AS SHOWN.

THE MARK CONSISTS OF THE PHRASE "SURGERY THEATER" IN A STRAIGHT LINE. THE LETTER "Y" IN "SURGERY" LOOKS LIKE A LONG SCALPEL, WHICH EXTENDS ABOVE THE PHRASE. THE TOP PORTION OF THE SCALPEL HAS A DISK CIRCLING IT. ADJACENT TO THE TOP OF THE SCALPEL THERE ARE FIVE FIGURES THAT LOOK LIKE THEY ARE WATCHING A MOVIE.

CLASS 38—COMMUNICATION

FOR STREAMING OF VIDEO MATERIAL ON THE INTERNET; VIDEO BROADCASTING SERVICES OVER THE INTERNET OR OTHER COMMUNICATIONS NETWORK FEATURING THE UPLOADED, POSTED AND TAGGED VIDEOS OF OTHERS (U.S. CLS. 100, 101 AND 104).

FIRST USE 6-1-2010; IN COMMERCE 6-1-2010.

CLASS 42—SCIENTIFIC AND COMPUTER SERVICES

FOR APPLICATION SERVICE PROVIDER (ASP) FEATURING SOFTWARE FOR USE IN UPLOADING, POSTING, SHOWING, DISPLAYING, TAGGING, BLOGGING, AND SHARING INFORMATION, PICTURES, VIDEOS, DRAWINGS AND OTHER DATA REGARDING SURGICAL AND MEDICAL PROCEDURES OVER THE INTERNET; PROVIDING A WEBSITE FEATURING TECHNOLOGY THAT ENABLES USERS TO VIEW, UPLOAD, AND SHARE USER-GENERATED VIDEOS ON SURGICAL AND MEDICAL PROCEDURES (U.S. CLS. 100 AND 101).

FIRST USE 6-1-2010; IN COMMERCE 6-1-2010.
BARBARA A. GOLD, EXAMINING ATTORNEY

SN 85-121,881. SEBRANEK, INC., BURLINGTON, WI. FILED 9-2-2010.

THOUGHTFUL LEARNING

THE MARK CONSISTS OF STANDARD CHARACTERS WITHOUT CLAIM TO ANY PARTICULAR FONT, STYLE, SIZE, OR COLOR.

NO CLAIM IS MADE TO THE EXCLUSIVE RIGHT TO USE "LEARNING", APART FROM THE MARK AS SHOWN.

CLASS 9—ELECTRICAL AND SCIENTIFIC APPARATUS

FOR AUDIO BOOKS IN THE FIELD OF K-12 EDUCATION (U.S. CLS. 21, 23, 26, 36 AND 38).

CLASS 16—PAPER GOODS AND PRINTED MATTER

FOR EDUCATIONAL PUBLICATIONS, NAMELY, BOOKS, WORKBOOKS, HAND-OUTS AND TEACHER GUIDES IN THE FIELDS OF K-12 EDUCATION (U.S. CLS. 2, 5, 22, 23, 29, 37, 38 AND 50).

CLASS 41—EDUCATION AND ENTERTAINMENT

FOR PROVIDING AN EDUCATIONAL WEBSITE IN THE FIELD OF K-12 EDUCATION (U.S. CLS. 100, 101 AND 107).

TIMOTHY FINNEGAN, EXAMINING ATTORNEY

SN 85-122,115. PLAB NEWCO A, INC., BROOKFIELD, CT. FILED 9-2-2010.

TRIANJA TECHNOLOGIES

THE MARK CONSISTS OF STANDARD CHARACTERS WITHOUT CLAIM TO ANY PARTICULAR FONT, STYLE, SIZE, OR COLOR.

NO CLAIM IS MADE TO THE EXCLUSIVE RIGHT TO USE "TECHNOLOGIES", APART FROM THE MARK AS SHOWN.

THE ENGLISH TRANSLATION OF "TRIANJA" IN THE MARK IS "THREE-PRONGED SPEAR".

CLASS 21—HOUSEWARES AND GLASS

FOR ARTICLES MANUFACTURED FROM FUSED SILICA IN THE NATURE OF PATTERNED QUARTZ SUBSTRATES FOR FURTHER MANUFACTURING USE IN MEDICAL DEVICES, SEMI CONDUCTOR DEVICES, BIOTECHNOLOGY DEVICES AND FLUIDIC DEVICES (U.S. CLS. 2, 13, 23, 29, 30, 33, 40 AND 50).

CLASS 40—MATERIAL TREATMENT

FOR CUSTOM MANUFACTURE FOR OTHERS OF PATTERNED QUARTZ SUBSTRATES (U.S. CLS. 100, 103 AND 106).

CLASS 42—SCIENTIFIC AND COMPUTER SERVICES

FOR CUSTOM DESIGN AND DEVELOPMENT FOR OTHERS OF PATTERNED QUARTZ SUBSTRATES (U.S. CLS. 100 AND 101).

NELSON SNYDER, EXAMINING ATTORNEY

SN 85-122,149. PLAB NEWCO A, INC., BROOKFIELD, CT. FILED 9-2-2010.

TRIANJA FLUIDICS

THE MARK CONSISTS OF STANDARD CHARACTERS WITHOUT CLAIM TO ANY PARTICULAR FONT, STYLE, SIZE, OR COLOR.

NO CLAIM IS MADE TO THE EXCLUSIVE RIGHT TO USE "FLUIDICS", APART FROM THE MARK AS SHOWN. THE ENGLISH TRANSLATION OF "TRIANJA" IN THE MARK IS "THREE-PRONGED SPEAR".

CLASS 21—HOUSEWARES AND GLASS

FOR ARTICLES MANUFACTURED FROM FUSED SILICA IN THE NATURE OF PATTERNED QUARTZ SUBSTRATES FOR FURTHER MANUFACTURING USE IN MEDICAL DEVICES, SEMI CONDUCTOR DEVICES, BIOTECHNOLOGY DEVICES AND FLUIDIC DEVICES (U.S. CLS. 2, 13, 23, 29, 30, 33, 40 AND 50).

CLASS 40—MATERIAL TREATMENT

FOR CUSTOM MANUFACTURE FOR OTHERS OF PATTERNED QUARTZ SUBSTRATES (U.S. CLS. 100, 103 AND 106).

CLASS 42—SCIENTIFIC AND COMPUTER SERVICES

FOR CUSTOM DESIGN AND DEVELOPMENT FOR OTHERS OF PATTERNED QUARTZ SUBSTRATES (U.S. CLS. 100 AND 101).

NELSON SNYDER, EXAMINING ATTORNEY

PRIORITY CLAIMED UNDER SEC. 44(D) ON ERPNTY TM OFC APPLICATION NO. 009352121, FILED 9-3-2010, REG. NO. 009352121, DATED 2-11-2011, EXPIRES 9-3-2020.

OWNER OF U.S. REG. NO. 3,795,406.

NO CLAIM IS MADE TO THE EXCLUSIVE RIGHT TO USE "PROTEOMICS", APART FROM THE MARK AS SHOWN.

CLASS 1—CHEMICALS

FOR BIOMEDICAL COMPOUNDS, NAMELY, PEPTIDE SUBSTRATES USED IN ANALYZING AND DETECTING CERTAIN TOXINS FOR LABORATORY, RESEARCH, CLINICAL OR MEDICAL LABORATORY USE; PROTEIN ARRAYS AND NUCLEOTIDE ARRAYS FOR SCIENTIFIC AND MEDICAL RESEARCH; BIO-CHEMICALS, NAMELY, MONOCLONAL ANTIBODIES FOR IN VITRO SCIENTIFIC OR RESEARCH USE (U.S. CLS. 1, 5, 6, 10, 26 AND 46).

CLASS 5—PHARMACEUTICALS

FOR SYNTHETIC PEPTIDES FOR THE TESTING OF BODY FLUIDS; NUTRITIVE SUBSTANCES FOR MICRO-ORGANISMS FOR MEDICAL USE (U.S. CLS. 6, 18, 44, 46, 51 AND 52).

JOHN GARTNER, EXAMINING ATTORNEY

SN 85-122,535. VICTOR J. BIERMAN III, EASTLAKE, OH. FILED 9-3-2010.

SN 85-122,765. VONAGE MARKETING LLC, HOLMDEL, NJ. FILED 9-3-2010.

CATHOLICS VS. CONVICTS

THE MARK CONSISTS OF STANDARD CHARACTERS WITHOUT CLAIM TO ANY PARTICULAR FONT, STYLE, SIZE, OR COLOR.

CLASS 16—PAPER GOODS AND PRINTED MATTER

FOR BUMPER STICKERS, PRINTED PAPER SIGNS, PENS, PENCILS, PAPER PENNANTS (U.S. CLS. 2, 5, 22, 23, 29, 37, 38 AND 50).

CLASS 25—CLOTHING

FOR SHIRTS, SWEATSHIRTS, HATS, WRISTBANDS, JACKETS, BOXER SHORTS, EAR BANDS, HEADBANDS, RAIN JACKETS (U.S. CLS. 22 AND 39).

RAMONA ORTIGA, EXAMINING ATTORNEY

SN 85-122,577. BAC IP B.V., 1411 GP NAARDEN, NETHERLANDS, FILED 9-3-2010.

PROTEOMICS TOOLBOX

THE MARK CONSISTS OF STANDARD CHARACTERS WITHOUT CLAIM TO ANY PARTICULAR FONT, STYLE, SIZE, OR COLOR.

VONAGE IM

THE MARK CONSISTS OF STANDARD CHARACTERS WITHOUT CLAIM TO ANY PARTICULAR FONT, STYLE, SIZE, OR COLOR.

OWNER OF U.S. REG. NOS. 3,370,706, 3,756,191 AND OTHERS.

NO CLAIM IS MADE TO THE EXCLUSIVE RIGHT TO USE "IM", APART FROM THE MARK AS SHOWN.

CLASS 9—ELECTRICAL AND SCIENTIFIC APPARATUS

FOR COMPUTER TELEPHONY SOFTWARE, NAMELY, SOFTWARE APPLICATION FOR ESTABLISHING AND PERFORMING PHONE CALLS OVER A VARIETY OF NETWORKS IN THE NATURE OF THE INTERNET; DOWNLOADABLE SOFTWARE FOR USE WITH WIRELESS TELECOMMUNICATIONS DEVICES TO PROVIDE WIRELESS TRANSMISSION OF E-MAIL, TEXT, MUSIC, VIDEO, VOICE, STILL IMAGES, INFORMATION, DATA, AND OTHER CONTENT VIA THE INTERNET AND VIA WIRELESS LOCAL AREA NETWORK DEVICES; COMPUTER AND TELECOMMUNICATIONS NETWORK HUBS, SWITCHES AND ROUTERS; COMPUTER HARDWARE AND COMMUNICATIONS SOFTWARE FOR USE IN CONNECTING TELECOMMUNICATIONS EQUIPMENT, TELEPHONES, COMPUTERS, WIRED AND WIRELESS COMPUTER NETWORKS; COMPUTER SOFTWARE AND HARDWARE FOR PROVIDING TRANSMISSION AND EXCHANGE OF VOICE, VIDEO, DATA, IMAGES AND GRAPHICS IN THE FIELD OF TELECOMMUNICATIONS; HARDWARE FOR TELECOMMUNICATIONS FOR CONNECTING DEVICES VIA IN-HOME PHONE AND ELECTRICAL WIRING, NAMELY, COMPUTER NETWORK HUBS, COMPUTER SWITCHES AND COMPUTER ROUTERS DESIGNED TO PROVIDE IN-HOME VOICE OVER INTERNET PROTOCOL (VOIP) COMMUNICATIONS (U.S. CLS. 21, 23, 26, 36 AND 38).

CLASS 38—COMMUNICATION

FOR TELEPHONY COMMUNICATIONS SERVICES (U.S. CLS. 100, 101 AND 104).
LESLEY LAMOTHE, EXAMINING ATTORNEY

SN 85-123,165. GENETIC TECHNOLOGIES LIMITED, FITZROY, VICTORIA 3065, AUSTRALIA, FILED 9-3-2010.

PHENOGEN SCIENCES

THE MARK CONSISTS OF STANDARD CHARACTERS WITHOUT CLAIM TO ANY PARTICULAR FONT, STYLE, SIZE, OR COLOR.

NO CLAIM IS MADE TO THE EXCLUSIVE RIGHT TO USE "SCIENCES", APART FROM THE MARK AS SHOWN. THE WORDING "PHENOGEN" HAS NO MEANING IN A FOREIGN LANGUAGE.

SN 85-123,051. KABUSHIKI KAISHA PEACE DINING, AKA PEACE DINING CORPORATION, TOKYO, JAPAN, FILED 9-3-2010.



CITY ROLLS

NO CLAIM IS MADE TO THE EXCLUSIVE RIGHT TO USE "ROLLS", APART FROM THE MARK AS SHOWN.

THE COLOR(S) GREEN AND BLACK IS/ARE CLAIMED AS A FEATURE OF THE MARK.

THE MARK CONSISTS OF A CIRCLE IN THE COLOR BLACK ABOVE THE WORDING "CITY ROLLS" IN THE COLOR BLACK, THE SAID CIRCLE HAVING A CURVED LINE IN THE COLOR BLACK EMANATING FROM ITS LOWER RIGHT PORTION AND FLOWING INTO THE CENTER OF THE CIRCLE, WITH THE LINE DIVERGING INTO THREE ABSTRACT BRANCHES IN THE COLOR BLACK NEAR THE CENTER OF THE CIRCLE, AND THERE BEING A SMALL, SOLID GREEN CIRCLE POSITIONED OVER THE SAID ABSTRACT BRANCHES.

CLASS 29—MEATS AND PROCESSED FOODS

FOR FROZEN, PREPARED AND PACKAGED ENTREES CONSISTING PRIMARILY OF MEAT, FISH, POULTRY OR VEGETABLES; FROZEN, PREPARED AND PACKAGED ASIAN-INSPIRED MEALS CONSISTING PRIMARILY OF MEAT, FISH, POULTRY OR VEGETABLES (U.S. CL. 46).

CLASS 30—STAPLE FOODS

FOR RICE; SUSHI; FROZEN, PREPARED AND PACKAGED ENTREES CONSISTING PRIMARILY OF PASTA OR RICE (U.S. CL. 46).

CLASS 35—ADVERTISING AND BUSINESS

FOR RETAIL STORE SERVICES FEATURING PREPARED FOODS AND SUSHI; WHOLESALE DISTRIBUTORSHIPS FEATURING PREPARED FOODS AND SUSHI (U.S. CLS. 100, 101 AND 102).

CLASS 39—TRANSPORTATION AND STORAGE

FOR DELIVERY OF FOOD BY RESTAURANTS (U.S. CLS. 100 AND 105).

CLASS 43—HOTEL AND RESTAURANT SERVICES

FOR RESTAURANT AND CATERING SERVICES (U.S. CLS. 100 AND 101).
LAURIE KAUFMAN, EXAMINING ATTORNEY

CLASS 42—SCIENTIFIC AND COMPUTER SERVICES

FOR PROVIDING REAGENT SAMPLE TESTING AND DIAGNOSTIC SERVICES FOR OTHERS IN THE FIELDS OF SCIENTIFIC AND MEDICAL RESEARCH; BIOTECHNOLOGY RESEARCH AND DEVELOPMENT SERVICES FOR OTHERS, NAMELY, GENETIC ASSOCIATION STUDIES, GENOME MAPPING, GENOME ANALYSIS, AND GENOME SCANNING, ALL FOR SCIENTIFIC RESEARCH PURPOSES; BIOTECHNOLOGY RESEARCH AND DEVELOPMENT SERVICES FOR OTHERS, NAMELY, PHARMACEUTICAL DRUG DEVELOPMENT SERVICES, THERAPEUTICS DRUG DEVELOPMENT SERVICES, CONSUMER HEALTH PRODUCT DEVELOPMENT FOR OTHERS AND CONSULTATION IN THE FIELD OF GENOMICS AND PHARMACEUTICAL DRUG DEVELOPMENT (U.S. CLS. 100 AND 101).

CLASS 44—MEDICAL, BEAUTY AND AGRICULTURAL SERVICES

FOR PROVIDING REAGENT SAMPLE TESTING AND DIAGNOSTIC SERVICES FOR OTHERS IN THE FIELD OF MEDICINE FOR MEDICAL PURPOSES; GENETIC TESTING FOR MEDICAL PURPOSES, NAMELY, GENOME MAPPING, GENOME ANALYSIS, AND GENOME SCANNING, ALL FOR MEDICAL TREATMENT PURPOSES (U.S. CLS. 100 AND 101).

BILL DAWE, EXAMINING ATTORNEY

SN 85-123,401. WASHINGTON TRUST BANK, SPOKANE, WA, FILED 9-5-2010.

ECLICK REWARDS

THE MARK CONSISTS OF STANDARD CHARACTERS WITHOUT CLAIM TO ANY PARTICULAR FONT, STYLE, SIZE, OR COLOR.

NO CLAIM IS MADE TO THE EXCLUSIVE RIGHT TO USE "REWARDS", APART FROM THE MARK AS SHOWN.

CLASS 35—ADVERTISING AND BUSINESS

FOR PROMOTING BANKING SERVICES THROUGH THE ADMINISTRATION OF INCENTIVE AWARD PROGRAMS (U.S. CLS. 100, 101 AND 102).

CLASS 36—INSURANCE AND FINANCIAL

FOR BANKING SERVICES (U.S. CLS. 100, 101 AND 102).
JESSICA A. POWERS, EXAMINING ATTORNEY

SN 85-123,402. WASHINGTON TRUST BANK, SPOKANE, WA. FILED 9-5-2010.

SN 85-124,150. EXCELLINE FOOD PRODUCTS, LLC, CHATSWORTH, CA. FILED 9-7-2010.

WTB CREDIT TRACKER

THE MARK CONSISTS OF STANDARD CHARACTERS WITHOUT CLAIM TO ANY PARTICULAR FONT, STYLE, SIZE, OR COLOR.

OWNER OF U.S. REG. NOS. 3,394,548 AND 3,781,572.
NO CLAIM IS MADE TO THE EXCLUSIVE RIGHT TO USE "CREDIT TRACKER", APART FROM THE MARK AS SHOWN.

CLASS 35—ADVERTISING AND BUSINESS

FOR PROVIDING BANKING CUSTOMERS WITH SELF-MONITORING AND TRACKING CAPABILITIES FOR THEIR VARIOUS ACCOUNTS AND CREDIT CARDS, NAMELY, MONITORING CONSUMER CREDIT REPORTS, ACCOUNTS AND PROVIDING AN ALERT AS TO ANY CHANGES THEREIN (U.S. CLS. 100, 101 AND 102).

CLASS 36—INSURANCE AND FINANCIAL

FOR BANKING SERVICES (U.S. CLS. 100, 101 AND 102).

JESSICA A. POWERS, EXAMINING ATTORNEY

SN 85-123,723. ABRAMS LEARNING & INFORMATION SYSTEMS, INC., AKA ALIS, INC., ARLINGTON, VA. FILED 9-7-2010.

NexMAP

THE MARK CONSISTS OF STANDARD CHARACTERS WITHOUT CLAIM TO ANY PARTICULAR FONT, STYLE, SIZE, OR COLOR.

CLASS 9—ELECTRICAL AND SCIENTIFIC APPARATUS

FOR COMPUTER SOFTWARE THAT PROVIDES REAL-TIME, INTEGRATED EMERGENCY MANAGEMENT INTELLIGENCE BY COMBINING INFORMATION FROM VARIOUS DATABASES AND PRESENTING IT IN AN EASY-TO-UNDERSTAND COMMON OPERATIONAL PICTURE AND SYSTEM FOR LAW ENFORCEMENT AND EMERGENCY MANAGEMENT PERSONNEL (U.S. CLS. 21, 23, 26, 36 AND 38).

CLASS 45—PERSONAL AND LEGAL SERVICES

FOR CONSULTING SERVICES IN THE FIELD OF HOMELAND SECURITY (U.S. CLS. 100 AND 101).
CHARISMA HAMPTON, EXAMINING ATTORNEY



THE MARK CONSISTS OF THE WORDS "HERB & GRILLE" IN STYLIZED FORM WITH A FLAME DESIGN REPLACING THE DOT IN THE LETTER "I" IN THE WORD "GRILLE", A STYLIZED DESIGN OF HERBS PLACED VERTICALLY AT A SLIGHT ANGLE DIRECTLY THROUGH THE AMPERSAND SYMBOL, AND A CURVED LINE BELOW THE WORDS "HERB & GRILLE".

CLASS 29—MEATS AND PROCESSED FOODS

FOR MEAT BASED SNACK FOODS; VEGETABLE BASED SNACK FOODS; POTATO BASED SNACK FOODS; HAM AND CHEESE SOUFFLÉS; FROZEN ENTREES CONSISTING PRIMARILY OF MEAT, SEAFOOD, POULTRY, OR VEGETABLES; PACKAGED ENTREES CONSISTING PRIMARILY OF MEAT, SEAFOOD, POULTRY, OR VEGETABLES; FROZEN APPETIZERS CONSISTING PRIMARILY OF MEAT, SEAFOOD, POULTRY, OR VEGETABLES; PACKAGED APPETIZERS CONSISTING PRIMARILY OF MEAT, SEAFOOD, POULTRY, OR VEGETABLES; FROZEN ENTREES CONSISTING PRIMARILY OF MEAT, VEGETABLES, AND CHEESE; FROZEN ENTREES CONSISTING PRIMARILY OF MEAT, POULTRY, OR VEGETABLES; PACKAGED ENTREES CONSISTING PRIMARILY OF MEAT, POULTRY, OR VEGETABLES; FROZEN APPETIZERS CONSISTING PRIMARILY OF MEAT, POULTRY, OR VEGETABLES; PACKAGED APPETIZERS CONSISTING PRIMARILY OF MEAT, POULTRY, OR VEGETABLES (U.S. CL. 46).

CLASS 30—STAPLE FOODS

FOR FROZEN ENTREES, NAMELY, POT PIES; PREPARED ENTREES NAMELY, POT PIES; FROZEN ENTREES CONSISTING PRIMARILY OF RICE WITH VEGETABLES; PREPARED FOODS, NAMELY TAQUITOS, FLAUTAS, QUESADILLAS, CHIMICHANGAS, BURRITOS, TACOS, ENCHILADAS, CHURROS, AND TAMALES; FROZEN FOODS, NAMELY TAQUITOS, FLAUTAS, QUESADILLAS, CHIMICHANGAS, BURRITOS, TACOS, ENCHILADAS, CHURROS AND TAMALES; FROZEN QUICHE; PREPARED QUICHE; CORN BASED SNACK FOODS; GRAIN BASED SNACK FOODS; PREPARED WRAP SANDWICHES; FROZEN WRAP SANDWICHES; PREPARED SANDWICHES; FROZEN SANDWICHES (U.S. CL. 46).

JEAN IM, EXAMINING ATTORNEY

SN 85-124,324. WATERLEAF LIMITED, DOUGLAS, ISLE OF MAN, FILED 9-7-2010.

MYSTERY MADNESS

THE MARK CONSISTS OF STANDARD CHARACTERS WITHOUT CLAIM TO ANY PARTICULAR FONT, STYLE, SIZE, OR COLOR.

CLASS 9—ELECTRICAL AND SCIENTIFIC APPARATUS

FOR COMPUTER GAMING SOFTWARE, DOWNLOADABLE COMPUTER GAMING SOFTWARE; COMPUTER GAMING PROGRAMS, DOWNLOADABLE COMPUTER GAMING PROGRAMS; COMPUTER HARDWARE, NAMELY, VIDEO GAME MACHINES FOR USE WITH EXTERNAL DISPLAY SCREEN OR MONITOR CONTAINING SOFTWARE WHICH ENABLES GAMING MACHINES TO RUN; STAND ALONE VIDEO GAMING MACHINES INCLUDING SLOT MACHINES OR VIDEO LOTTERY TERMINALS (U.S. CLS. 21, 23, 26, 36 AND 38).

CLASS 28—TOYS AND SPORTING GOODS

FOR STAND ALONE VIDEO GAME MACHINES OTHER THAN THOSE ADAPTED FOR USE WITH TELEVISION RECEIVERS; STAND ALONE VIDEO OUTPUT GAME MACHINES OTHER THAN THOSE ADAPTED FOR USE WITH TELEVISION RECEIVERS; STAND ALONE ARCADE GAME MACHINES OTHER THAN THOSE ADAPTED FOR USE WITH TELEVISION RECEIVERS (U.S. CLS. 22, 23, 38 AND 50).

CLASS 41—EDUCATION AND ENTERTAINMENT

FOR ENTERTAINMENT SERVICES, NAMELY, CASINO GAMBLING; ENTERTAINMENT, NAMELY, PROVIDING ON-LINE COMPUTER GAMES; PROVIDING ON-LINE CARD GAMES; PROVIDING A WEB-BASED SYSTEM AND ON-LINE PORTAL FOR CUSTOMERS TO PARTICIPATE IN ON-LINE GAMING, OPERATION AND COORDINATION OF GAME TOURNAMENTS, LEAGUES AND TOURS (U.S. CLS. 100, 101 AND 107).
MICHAEL SOUDERS, EXAMINING ATTORNEY

SN 85-124,381. MISFIT PRODUCTIONS, LLC, SANTA MONICA, CA. FILED 9-7-2010.

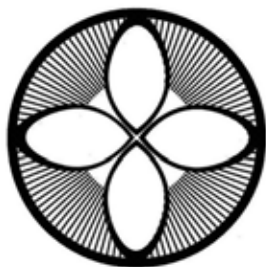

THE MARK CONSISTS OF A CIRCLE LOGO DESIGN WITH FOUR EQUALLY SPACED OVAL/TEAR SHAPED DESIGNS INSIDE THE CIRCLE ALONG WITH EQUALLY SPACED LINES ANGLED INWARD FROM THE CIRCLES BORDER.

CLASS 9—ELECTRICAL AND SCIENTIFIC APPARATUS

FOR PRE-RECORDED VIDEO TAPES AND DIGITAL VIDEO DISKS FEATURING FITNESS PROGRAMS, EDUCATIONAL AND INSTRUCTIONAL MATERIALS RELATING TO FITNESS, HEALTH, WEIGHT LOSS AND LIFESTYLE (U.S. CLS. 21, 23, 26, 36 AND 38).
FIRST USE 6-1-2009; IN COMMERCE 10-1-2009.

CLASS 25—CLOTHING

FOR MEN'S AND WOMEN'S EXERCISE APPAREL, NAMELY, T-SHIRTS, SHIRTS, TANK TOPS, LEOTARDS, JACKETS, VESTS, PANTS, TIGHTS, SWEATPANTS, SWEATSHIRTS, SHORTS, SPORTS BRAS, SOCKS AND ATHLETIC APPAREL ACCESSORIES, NAMELY, SWEAT BANDS, HEADBANDS AND WRISTBANDS (U.S. CLS. 22 AND 39).

FIRST USE 6-1-2009; IN COMMERCE 6-1-2009.

CLASS 28—TOYS AND SPORTING GOODS

FOR EXERCISE EQUIPMENT, NAMELY, MANUALLY-OPERATED EXERCISE EQUIPMENT AND KETTLEBELLS; EXERCISE EQUIPMENT, NAMELY, PERSONAL BODY-TRAINING APPARATUS, PERSONAL FITNESS EXERCISES MATS AND YOGA MATS (U.S. CLS. 22, 23, 38 AND 50).

FIRST USE 10-1-2009; IN COMMERCE 10-1-2009.

JULIE WATSON, EXAMINING ATTORNEY

SN 85-124,854. STATE STREET CORPORATION, BOSTON, MA. FILED 9-8-2010.

DC NOW

THE MARK CONSISTS OF STANDARD CHARACTERS WITHOUT CLAIM TO ANY PARTICULAR FONT, STYLE, SIZE, OR COLOR.

NO CLAIM IS MADE TO THE EXCLUSIVE RIGHT TO USE "DC", APART FROM THE MARK AS SHOWN.

CLASS 16—PAPER GOODS AND PRINTED MATTER

FOR FINANCIAL INFORMATION, NAMELY, PRINTED MATERIALS, NAMELY, WRITTEN ARTICLES AND WHITE PAPERS IN THE FIELD OF DEFINED CONTRIBUTION PLANS (U.S. CLS. 2, 5, 22, 23, 29, 37, 38 AND 50).

CLASS 36—INSURANCE AND FINANCIAL

FOR PROVIDING FINANCIAL INFORMATION IN THE FIELD OF DEFINED CONTRIBUTION PLANS (U.S. CLS. 100, 101 AND 102).

INGRID C. EULIN, EXAMINING ATTORNEY

SN 85-125,563. JOHNSON & JOHNSON, NEW BRUNSWICK, NJ. FILED 9-9-2010.

TOGETHER WE'RE MORE

THE MARK CONSISTS OF STANDARD CHARACTERS WITHOUT CLAIM TO ANY PARTICULAR FONT, STYLE, SIZE, OR COLOR.

CLASS 16—PAPER GOODS AND PRINTED MATTER

FOR PRINTED PUBLICATIONS IN THE FIELD OF BUSINESS, FOR USE BY OTHERS IN ENHANCING NEW PRODUCT, NEW SERVICE, AND NEW BUSINESS MODEL DEVELOPMENT EFFORTS, NAMELY, POSTERS, TEACHING MATERIALS AND ADVERTISING MATERIALS (U.S. CLS. 2, 5, 22, 23, 29, 37, 38 AND 50).

CLASS 35—ADVERTISING AND BUSINESS

FOR BUSINESS INFORMATION IN THE FIELD OF NEW PRODUCT, NEW SERVICE, AND NEW BUSINESS MODEL DEVELOPMENT PROCESSES FOR USE BY OTHERS, NAMELY, INDEPENDENT BUSINESS PARTNERS (U.S. CLS. 100, 101 AND 102).

ELLEN BURNS, EXAMINING ATTORNEY

SN 85-125,771. SHELTERBOX TRUST, HELSTON, CORNWALL, UNITED KINGDOM, FILED 9-9-2010.

SHELTERBOX

THE MARK CONSISTS OF STANDARD CHARACTERS WITHOUT CLAIM TO ANY PARTICULAR FONT, STYLE, SIZE, OR COLOR.

PRIORITY CLAIMED UNDER SEC. 44(D) ON UNITED KINGDOM APPLICATION NO. 2541240, FILED 3-9-2010, REG. NO. 2541240, DATED 7-16-2010, EXPIRES 3-9-2020.

CLASS 6—METAL GOODS

FOR SHELTERS AND BUILDING STRUCTURES OF METAL; MODULAR SHELTERS OF METAL; PORTABLE SHELTERS OF METAL (U.S. CLS. 2, 12, 13, 14, 23, 25 AND 50).

CLASS 9—ELECTRICAL AND SCIENTIFIC APPARATUS

FOR SURVIVAL KITS FOR USE BY VICTIMS OF DISASTERS, PROVIDED AS A UNIT, CONSISTING PRINCIPALLY OF ROPES, LAMPS, FLASHLIGHTS, A COOK STOVE AND COOKING EQUIPMENT, WATER FILTERING EQUIPMENT AND WATER STERILIZERS, PONCHOS, HOUSEHOLD AND KITCHEN UTENSILS, NAMELY, BOWLS, CROCKERY, DISHES, GLASSES, CUPS, FLASKS, BUCKETS, JUGS, JARS, AND PLATES, GLOVES, HATS, SCARVES, PRINTED MATTER, NAMELY, COLORING BOOKS, DRAWING PAPER, NOTEBOOKS, AND WRITING UTENSILS, NAMELY, PENCILS, PENCIL SHARPENERS, PENCIL ERASERS, COLORED PENCILS, PENS, CHALK, CHALK ERASERS, AND CRAYONS (U.S. CLS. 21, 23, 26, 36 AND 38).

CLASS 19—NON-METALLIC BUILDING MATERIALS

FOR NON-METALLIC SHELTERS; BUILDING STRUCTURES OF NON-METALLIC MATERIALS; NON-METALLIC PORTABLE SHELTERS (U.S. CLS. 1, 12, 33 AND 50).

CLASS 24—FABRICS

FOR THERMAL BLANKETS FOR OUTDOOR USE (U.S. CLS. 42 AND 50).

CLASS 25—CLOTHING

FOR CLOTHING, NAMELY, SHIRTS, SWEATERS, T-SHIRTS, POLO SHIRTS, JACKETS, VESTS, AND FLEECE PULLOVERS; HEADWEAR; FOOTWEAR (U.S. CLS. 22 AND 39).

CLASS 35—ADVERTISING AND BUSINESS

FOR CHARITABLE SERVICES, NAMELY, ORGANIZING AND CONDUCTING VOLUNTEER PROGRAMS AND COMMUNITY SERVICE PROJECTS; PROMOTING PUBLIC AWARENESS OF THE NEED FOR PARTICIPATING IN CHARITABLE SERVICES BY PROVIDING INFORMATION ABOUT VOLUNTEER PROGRAMS; PROVIDING INFORMATION RELATING TO CHARITABLE BUSINESSES (U.S. CLS. 100, 101 AND 102).

CLASS 36—INSURANCE AND FINANCIAL

FOR FUND RAISING FOR CHARITABLE PURPOSES; PROVIDING INFORMATION ABOUT CHARITABLE FUNDRAISING (U.S. CLS. 100, 101 AND 102).

SN 85-125,564. JOHNSON & JOHNSON, NEW BRUNSWICK, NJ. FILED 9-9-2010.



THE COLOR(S) GREEN, BLUE AND WHITE IS/ARE CLAIMED AS A FEATURE OF THE MARK.

THE MARK CONSISTS OF A GREEN ARROW AND BLUE ARROW POINTING AT EACH OTHER AGAINST BLUE AND WHITE CLOUDS WITH THE STYLIZED PHRASE "TOGETHER WE'RE MORE" IN WHITE DISPLAYED IN THE ARROWS. THE ARROWS INTERSECT AT THE CENTER FORMING A SHADED DIAMOND IN BLUE.

CLASS 16—PAPER GOODS AND PRINTED MATTER

FOR PRINTED PUBLICATIONS IN THE FIELD OF BUSINESS, FOR USE BY OTHERS IN ENHANCING NEW PRODUCT, NEW SERVICE, AND NEW BUSINESS MODEL DEVELOPMENT EFFORTS, NAMELY, POSTERS, TEACHING MATERIALS AND ADVERTISING MATERIALS (U.S. CLS. 2, 5, 22, 23, 29, 37, 38 AND 50).

CLASS 35—ADVERTISING AND BUSINESS

FOR BUSINESS INFORMATION IN THE FIELD OF NEW PRODUCT, NEW SERVICE, AND NEW BUSINESS MODEL DEVELOPMENT PROCESSES FOR USE BY OTHERS, NAMELY, INDEPENDENT BUSINESS PARTNERS (U.S. CLS. 100, 101 AND 102).

ELLEN BURNS, EXAMINING ATTORNEY

CLASS 37—CONSTRUCTION AND REPAIR

FOR CHARITABLE SERVICES, NAMELY, CONSTRUCTION OF TEMPORARY ACCOMMODATION AND TENTED VILLAGES (U.S. CLS. 100, 103 AND 106).

SN 85-125,961. SINCLAIR SRL, 36063 MAROSTICA (VI), ITALY, FILED 9-9-2010.

CLASS 39—TRANSPORTATION AND STORAGE

FOR CHARITABLE SERVICES, NAMELY, STORAGE, PACKING AND DISTRIBUTION OF GOODS INCLUDING TENTS, CONTAINERS AND CAMPING FURNITURE (U.S. CLS. 100 AND 105).

MARINI

THE MARK CONSISTS OF STANDARD CHARACTERS WITHOUT CLAIM TO ANY PARTICULAR FONT, STYLE, SIZE, OR COLOR.

OWNER OF U.S. REG. NO. 2,872,929.
SEC. 2(F).

CLASS 41—EDUCATION AND ENTERTAINMENT

FOR EDUCATIONAL TRAINING SERVICES RELATED TO DISASTER RELIEF AND ALLEVIATING SUFFERING IN ANY PART OF THE WORLD (U.S. CLS. 100, 101 AND 107).

CLASS 18—LEATHER GOODS

FOR BAGS, NAMELY, SHOULDER BAGS, TOTE BAGS AND PURSES (U.S. CLS. 1, 2, 3, 22 AND 41).
FIRST USE 1-0-1991; IN COMMERCE 0-0-2001.

CLASS 43—HOTEL AND RESTAURANT SERVICES

FOR CHARITABLE SERVICES, NAMELY, PROVIDING TEMPORARY ACCOMMODATION (U.S. CLS. 100 AND 101).

PAM WILLIS, EXAMINING ATTORNEY

CLASS 25—CLOTHING

FOR CLOTHING, NAMELY, COATS, LONG COATS, HALF COATS, JACKETS, BLAZERS, WAISTCOATS, TROUSERS, SHORTS, SKIRTS, DRESSES, VESTS, HATS, CAPS, GLOVES, SCARVES (U.S. CLS. 22 AND 39).
FIRST USE 1-0-1991; IN COMMERCE 0-0-2001.

KEVON CHISOLM, EXAMINING ATTORNEY

SN 85-125,870. AEOLUS DOWN, INC., CHINO, CA. FILED 9-9-2010.

SN 85-125,996. STANLEY LOGISTICS, L.L.C., NEW BRITAIN, CT. FILED 9-9-2010.

SLUMBER Rx



THE MARK CONSISTS OF STANDARD CHARACTERS WITHOUT CLAIM TO ANY PARTICULAR FONT, STYLE, SIZE, OR COLOR.

CLASS 20—FURNITURE AND ARTICLES NOT OTHERWISE CLASSIFIED

FOR BED PILLOWS; MATTRESS TOPPERS (U.S. CLS. 2, 13, 22, 25, 32 AND 50).

NO CLAIM IS MADE TO THE EXCLUSIVE RIGHT TO USE "CARBIDE", APART FROM THE MARK AS SHOWN.

THE MARK CONSISTS OF THE WORD "CARBIDE" IN FANCIFUL ITALICIZED BOLD BLOCK LETTERS WITH THE FRONT LINE OF THE LETTER "A" CURVED AND EXTENDED AND WITH THE LAST LINE OF THE LETTER "A" NOT EXTENDED PAST THE MIDDLE BAR OF THE LETTER "A".

CLASS 22—CORDAGE AND FIBERS

FOR DOWN FEATHERS (U.S. CLS. 1, 2, 7, 19, 22, 42 AND 50).

CLASS 7—MACHINERY

FOR CARBIDE BLADES FOR USE WITH POWER SAWS, NAMELY, RECIPROCATING SAWS (U.S. CLS. 13, 19, 21, 23, 31, 34 AND 35).

CLASS 24—FABRICS

FOR COMFORTERS; MATTRESS PADS (U.S. CLS. 42 AND 50).
EUGENIA MARTIN, EXAMINING ATTORNEY

CLASS 8—HAND TOOLS

FOR CARBIDE BLADES FOR USE WITH HAND TOOLS, NAMELY, UTILITY KNIVES AND HACKSAWS (U.S. CLS. 23, 28 AND 44).
DAVID ELTON, EXAMINING ATTORNEY

SN 85-126,173. PRADA S.A., LUXEMBOURG 1118, LUXEMBOURG, FILED 9-9-2010.

PRADA MILANO

THE MARK CONSISTS OF STANDARD CHARACTERS WITHOUT CLAIM TO ANY PARTICULAR FONT, STYLE, SIZE, OR COLOR.

OWNER OF U.S. REG. NOS. 1,400,409, 2,162,795 AND OTHERS.

NO CLAIM IS MADE TO THE EXCLUSIVE RIGHT TO USE "MILANO", APART FROM THE MARK AS SHOWN. THE ENGLISH TRANSLATION OF "MILANO" IN THE MARK IS "MILAN".

CLASS 9—ELECTRICAL AND SCIENTIFIC APPARATUS

FOR SUNGLASSES, EYEGLASS FRAMES, EYEGLASS CASES, CONTACT LENS CASES; BATTERY CHARGERS AND CASES FOR BATTERY CHARGERS; LAPTOP CARRYING CASES; DECORATIVE ORNAMENTS FOR CELLULAR TELEPHONES (U.S. CLS. 21, 23, 26, 36 AND 38).

FIRST USE 0-0-2001; IN COMMERCE 0-0-2001.

CLASS 14—JEWELRY

FOR JEWELRY; PERSONAL ORNAMENTS OF PRECIOUS METAL (U.S. CLS. 2, 27, 28 AND 50).

FIRST USE 0-0-2001; IN COMMERCE 0-0-2001.

CLASS 16—PAPER GOODS AND PRINTED MATTER

FOR PASSPORT CASES (U.S. CLS. 2, 5, 22, 23, 29, 37, 38 AND 50).

FIRST USE 0-0-2001; IN COMMERCE 0-0-2001.

CLASS 18—LEATHER GOODS

FOR HANDBAGS, WALLETS, CREDIT CARD CASES, LEATHER KEY CHAINS, LUGGAGE TAGS, LUGGAGE, TOTE BAGS, BRIEFCASES, DOCUMENT CASES, TOILETRY CASES SOLD EMPTY, COSMETIC BAGS SOLD EMPTY (U.S. CLS. 1, 2, 3, 22 AND 41).

FIRST USE 0-0-2001; IN COMMERCE 0-0-2001.

CLASS 25—CLOTHING

FOR SHIRTS, SKIRTS, DRESSES, PANTS, JACKETS, COATS, SUITS, LEGGINGS, SWEATERS, BELTS, SCARVES, GLOVES; FOOTWEAR (U.S. CLS. 22 AND 39).

FIRST USE 0-0-2001; IN COMMERCE 0-0-2001.

AMEEN IMAM, EXAMINING ATTORNEY

SN 85-126,461. NXT TECHNOLOGIES, LLC, HOUSTON, TX, FILED 9-9-2010.

DECXON

THE MARK CONSISTS OF STANDARD CHARACTERS WITHOUT CLAIM TO ANY PARTICULAR FONT, STYLE, SIZE, OR COLOR.

CLASS 2—PAINTS

FOR BUILDING AND ROOFING MATERIALS, NAMELY, ELASTOMERIC-BASED ROOF COATINGS, RESIN-BASED ROOF COATINGS, POLYMER AND/OR SILICONE ENHANCED ELASTOMERIC-BASED, RESIN BASED, AND WATER BASED ROOF COATING, AND WATER RESISTANT ROOF COATINGS (U.S. CLS. 6, 11 AND 16).

CLASS 19—NON-METALLIC BUILDING MATERIALS

FOR BUILDING AND ROOFING MATERIALS, NAMELY, ASPHALT BASED ROOF COATINGS, ASPHALT POLYMER AND/OR SILICONE ENHANCED ASPHALT ROOF COATING, ASPHALT ROOF COATING, AND WATER RESISTANT ASPHALT BASED ROOF COATINGS (U.S. CLS. 1, 12, 33 AND 50).

CAROLYN CATALDO, EXAMINING ATTORNEY

SN 85-126,666. BRAVEWELL COLLABORATIVE, MINNEAPOLIS, MN, FILED 9-10-2010.

THE BRAVEWELL COLLABORATIVE

THE MARK CONSISTS OF STANDARD CHARACTERS WITHOUT CLAIM TO ANY PARTICULAR FONT, STYLE, SIZE, OR COLOR.

NO CLAIM IS MADE TO THE EXCLUSIVE RIGHT TO USE "COLLABORATIVE", APART FROM THE MARK AS SHOWN.

CLASS 9—ELECTRICAL AND SCIENTIFIC APPARATUS

FOR PRE-RECORDED CDS AND DVDS IN THE FIELD OF INTEGRATIVE MEDICINE; DOWNLOADABLE ELECTRONIC PUBLICATIONS IN THE NATURE OF E-BOOKS, E-BOOKLETS AND E-NEWSLETTERS IN THE FIELD OF INTEGRATIVE MEDICINE; DOWNLOADABLE ONLINE ELECTRONIC PUBLICATIONS IN THE NATURE OF NEWSLETTERS, PAMPHLETS, BOOKS, PAPERS, REPORTS AND STUDIES IN THE FIELD OF INTEGRATIVE MEDICINE; DOWNLOADABLE ELECTRONIC PUBLICATIONS IN THE NATURE OF E-BOOKS, E-BOOKLETS AND E-NEWSLETTERS IN THE FIELD OF INTEGRATIVE MEDICINE WHICH MAY CONTAIN ACCOMPANYING ELECTRONIC SLIDE PRESENTATIONS (U.S. CLS. 21, 23, 26, 36 AND 38).

FIRST USE 4-0-2004; IN COMMERCE 4-0-2004.

CLASS 16—PAPER GOODS AND PRINTED MATTER

FOR WRITTEN MATERIALS IN THE FIELD OF INTEGRATIVE MEDICINE, NAMELY, PAMPHLETS, NEWSLETTERS, BOOKS, PAPERS, REPORTS AND STUDIES (U.S. CLS. 2, 5, 22, 23, 29, 37, 38 AND 50).

FIRST USE 4-0-2004; IN COMMERCE 4-0-2004.

CLASS 35—ADVERTISING AND BUSINESS

FOR PROMOTING PUBLIC AWARENESS OF HEALTH ISSUES; CHARITABLE SERVICES, NAMELY, PROVIDING SUPPORT IN THE NATURE OF ORGANIZING AND DEVELOPING PROJECTS THAT AIM TO PROMOTE NATIONAL AWARENESS FOR THE ADVANCEMENT OF INTEGRATIVE MEDICINE, MEDICAL EDUCATION AND RESEARCH; PHILANTHROPY SERVICES TO SUPPORT AND BENEFIT THE ADVANCEMENT OF INTEGRATIVE MEDICINE, NAMELY, CHARITABLE PROMOTION OF PROGRAMS THAT WILL ADVANCE INTEGRATIVE MEDICINE THROUGH MEDICAL EDUCATION, RESEARCH, COLLABORATION, DELIVERY OF HEALTHCARE AND PUBLIC RELATIONS; PHILANTHROPY SERVICES TO PROMOTE THE ADVANCEMENT OF INTEGRATIVE MEDICINE THROUGH HOSTING PROMOTIONAL CHARITY EVENTS; PHILANTHROPY SERVICES, NAMELY, CONVENING PARTNERS TO SUPPORT AND BENEFIT THE ADVANCEMENT OF INTEGRATIVE MEDICINE THROUGH HOSTING PROMOTIONAL CHARITY EVENTS (U.S. CLS. 100, 101 AND 102).

FIRST USE 4-0-2004; IN COMMERCE 4-0-2004.

CLASS 36—INSURANCE AND FINANCIAL

FOR CHARITABLE FOUNDATION SERVICES, NAMELY, PROVIDING FINANCIAL SUPPORT FOR THE ADVANCEMENT OF INTEGRATIVE MEDICINE, MEDICAL EDUCATION AND RESEARCH; CHARITABLE SERVICES BY MEANS OF ORGANIZING AND CONDUCTING SPECIAL EVENTS THAT CREATE STRATEGIC PARTNERSHIPS TO FACILITATE FINANCIAL SUPPORT OF THE ADVANCEMENT OF INTEGRATIVE MEDICINE; PHILANTHROPIC SERVICES CONCERNING MONETARY DONATIONS TO SUPPORT AND BENEFIT THE ADVANCEMENT OF INTEGRATIVE MEDICINE (U.S. CLS. 100, 101 AND 102).

FIRST USE 4-0-2004; IN COMMERCE 4-0-2004.

CLASS 41—EDUCATION AND ENTERTAINMENT

FOR NON-DOWNLOADABLE ELECTRONIC PUBLICATIONS IN THE NATURE OF E-BOOKS, E-BOOKLETS AND E-NEWSLETTERS IN THE FIELD OF INTEGRATIVE MEDICINE; NON-DOWNLOADABLE ONLINE ELECTRONIC PUBLICATIONS IN THE NATURE OF NEWSLETTERS, PAMPHLETS, BOOKS, PAPERS, REPORTS AND STUDIES IN THE FIELD OF INTEGRATIVE MEDICINE; CHARITABLE SERVICES IN THE NATURE OF ORGANIZING STRATEGIC PARTNERSHIPS TO AID, SUPPORT AND PROMOTE THE ADVANCEMENT OF INTEGRATIVE MEDICINE, NAMELY, DEVELOPING EDUCATIONAL MEETINGS AND WORKSHOPS TO HELP EDUCATE AND INFORM OTHERS ABOUT THE CLINICAL AND COST BENEFITS OF INTEGRATIVE MEDICINE; NON-DOWNLOADABLE ELECTRONIC PUBLICATIONS IN THE NATURE OF DOCUMENTS IN THE FIELD OF INTEGRATIVE MEDICINE (U.S. CLS. 100, 101 AND 107).

FIRST USE 4-0-2004; IN COMMERCE 4-0-2004.

CLASS 42—SCIENTIFIC AND COMPUTER SERVICES

FOR PROVIDING SCIENTIFIC RESEARCH SERVICES IN THE FIELD OF INTEGRATIVE MEDICINE; PROVIDING SCIENTIFIC AND MEDICAL RESEARCH TO INCREASE THE KNOWLEDGE AND EVIDENCE BASED PRACTICE OF INTEGRATIVE MEDICINE (U.S. CLS. 100 AND 101).

FIRST USE 4-0-2004; IN COMMERCE 4-0-2004.

CLASS 44—MEDICAL, BEAUTY AND AGRICULTURAL SERVICES

FOR PROVIDING INFORMATION IN THE FIELD OF INTEGRATIVE MEDICINE; INFORMATION SERVICES, NAMELY, PROVIDING A WEBSITE FEATURING INFORMATION ABOUT THE FIELD OF INTEGRATIVE MEDICINE; PROVIDING INFORMATION IN THE FIELD OF HEALTH AWARENESS (U.S. CLS. 100 AND 101).

FIRST USE 4-0-2004; IN COMMERCE 4-0-2004.

TINA BROWN, EXAMINING ATTORNEY

SN 85-126,668. RANDOLPH MORRIS, INC., MOUNTAIN-TOP, PA. FILED 9-10-2010.



THE MARK CONSISTS OF A STYLIZED OVERLAY OF THE LETTERS "R" AND "M".

CLASS 11—ENVIRONMENTAL CONTROL APPARATUS

FOR BATH TUBS; FAUCETS; SHOWER ENCLOSURES; SHOWER HEADS; PLUMBING FITTINGS, NAMELY, SPOUTS, SPIGOTS, DRAINS, VALVES AND TRAPS; PIPES BEING PARTS OF BATH, SHOWER, SINK AND TOILET INSTALLATIONS (U.S. CLS. 13, 21, 23, 31 AND 34).

FIRST USE 12-6-2007; IN COMMERCE 12-6-2007.

CLASS 20—FURNITURE AND ARTICLES NOT OTHERWISE CLASSIFIED

FOR SHOWER CURTAIN RINGS; SHOWER CURTAIN RODS; MIRRORS (U.S. CLS. 2, 13, 22, 25, 32 AND 50).

FIRST USE 12-6-2007; IN COMMERCE 12-6-2007.

CLASS 21—HOUSEWARES AND GLASS

FOR BATH SOAP DISHES (U.S. CLS. 2, 13, 23, 29, 30, 33, 40 AND 50).

FIRST USE 12-6-2007; IN COMMERCE 12-6-2007.

CLASS 24—FABRICS

FOR SHOWER CURTAINS; SHOWER CURTAIN LINERS (U.S. CLS. 42 AND 50).

FIRST USE 12-6-2007; IN COMMERCE 12-6-2007.

SANJEEV VOHRA, EXAMINING ATTORNEY

SN 85-126,677. RANDOLPH MORRIS, INC., MOUNTAIN-TOP, PA. FILED 9-10-2010.

RANDOLPH MORRIS

THE MARK CONSISTS OF STANDARD CHARACTERS WITHOUT CLAIM TO ANY PARTICULAR FONT, STYLE, SIZE, OR COLOR.

THE NAME(S), PORTRAIT(S), AND/OR SIGNATURE(S) SHOWN IN THE MARK DOES NOT IDENTIFY A PARTICULAR LIVING INDIVIDUAL.

CLASS 11—ENVIRONMENTAL CONTROL APPARATUS

FOR BATH TUBS; FAUCETS; SHOWER ENCLOSURES; SHOWER HEADS; PLUMBING FITTINGS, NAMELY, SPOUTS, SPIGOTS, DRAINS, VALVES AND TRAPS; PIPES BEING PARTS OF BATH, SHOWER, SINK AND TOILET INSTALLATIONS (U.S. CLS. 13, 21, 23, 31 AND 34).

FIRST USE 12-6-2007; IN COMMERCE 12-6-2007.

CLASS 20—FURNITURE AND ARTICLES NOT OTHERWISE CLASSIFIED

FOR SHOWER CURTAIN RINGS; SHOWER CURTAIN RODS; MIRRORS (U.S. CLS. 2, 13, 22, 25, 32 AND 50).

FIRST USE 12-6-2007; IN COMMERCE 12-6-2007.

CLASS 21—HOUSEWARES AND GLASS

FOR BATH SOAP DISHES (U.S. CLS. 2, 13, 23, 29, 30, 33, 40 AND 50).

FIRST USE 12-6-2007; IN COMMERCE 12-6-2007.

CLASS 24—FABRICS

FOR SHOWER CURTAINS; SHOWER CURTAIN LINERS (U.S. CLS. 42 AND 50).

FIRST USE 12-6-2007; IN COMMERCE 12-6-2007.

SANJEEV VOHRA, EXAMINING ATTORNEY

SN 85-126,688. BRAVEWELL COLLABORATIVE, MINNEAPOLIS, MN. FILED 9-10-2010.



THE MARK CONSISTS OF FOUR CURVED LINES EXTENDING OUTWARD FROM A SQUARE WHICH FORMS A SWIRL DESIGN WITH FOUR CIRCLES POSITIONED BENEATH THE CURVE OF EACH OF THE CURVED LINES.

CLASS 9—ELECTRICAL AND SCIENTIFIC APPARATUS

FOR PRE-RECORDED CDS AND DVDS IN THE FIELD OF INTEGRATIVE MEDICINE; DOWNLOADABLE ELECTRONIC PUBLICATIONS IN THE NATURE OF E-BOOKS, E-BOOKLETS AND E-NEWSLETTERS IN THE FIELD OF INTEGRATIVE MEDICINE; DOWNLOADABLE ONLINE ELECTRONIC PUBLICATIONS IN THE NATURE OF NEWSLETTERS, PAMPHLETS, BOOKS, PAPERS, REPORTS AND STUDIES IN THE FIELD OF INTEGRATIVE MEDICINE; DOWNLOADABLE ELECTRONIC PUBLICATIONS IN THE NATURE OF E-BOOKS, E-BOOKLETS AND E-NEWSLETTERS IN THE FIELD OF INTEGRATIVE MEDICINE WHICH MAY CONTAIN ACCOMPANYING ELECTRONIC SLIDE PRESENTATIONS (U.S. CLS. 21, 23, 26, 36 AND 38).

FIRST USE 4-0-2004; IN COMMERCE 4-0-2004.

CLASS 16—PAPER GOODS AND PRINTED MATTER

FOR WRITTEN MATERIALS IN THE FIELD OF INTEGRATIVE MEDICINE, NAMELY, PAMPHLETS, NEWSLETTERS, BOOKS, PAPERS, REPORTS AND STUDIES (U.S. CLS. 2, 5, 22, 23, 29, 37, 38 AND 50).

FIRST USE 4-0-2004; IN COMMERCE 4-0-2004.

CLASS 35—ADVERTISING AND BUSINESS

FOR PROMOTING PUBLIC AWARENESS OF HEALTH ISSUES; CHARITABLE SERVICES, NAMELY, PROVIDING SUPPORT IN THE NATURE OF ORGANIZING AND DEVELOPING PROJECTS THAT AIM TO PROMOTE NATIONAL AWARENESS FOR THE ADVANCEMENT OF INTEGRATIVE MEDICINE, MEDICAL EDUCATION AND RESEARCH; PHILANTHROPY SERVICES TO SUPPORT AND BENEFIT THE ADVANCEMENT OF INTEGRATIVE MEDICINE, NAMELY, CHARITABLE PROMOTION OF PROGRAMS THAT WILL ADVANCE INTEGRATIVE MEDICINE THROUGH MEDICAL EDUCATION, RESEARCH, COLLABORATION, DELIVERY OF HEALTHCARE AND PUBLIC RELATIONS; PHILANTHROPY SERVICES TO PROMOTE THE ADVANCEMENT OF INTEGRATIVE MEDICINE THROUGH HOSTING PROMOTIONAL CHARITY EVENTS; PHILANTHROPY SERVICES, NAMELY, CONVENING PARTNERS TO SUPPORT AND BENEFIT THE ADVANCEMENT OF INTEGRATIVE MEDICINE THROUGH HOSTING PROMOTIONAL CHARITY EVENTS (U.S. CLS. 100, 101 AND 102).

FIRST USE 4-0-2004; IN COMMERCE 4-0-2004.

CLASS 36—INSURANCE AND FINANCIAL

FOR CHARITABLE FOUNDATION SERVICES, NAMELY, PROVIDING FINANCIAL SUPPORT FOR THE ADVANCEMENT OF INTEGRATIVE MEDICINE, MEDICAL EDUCATION AND RESEARCH; CHARITABLE SERVICES BY MEANS OF ORGANIZING AND CONDUCTING SPECIAL EVENTS THAT CREATE STRATEGIC PARTNERSHIPS TO FACILITATE FINANCIAL SUPPORT OF THE ADVANCEMENT OF INTEGRATIVE MEDICINE; PHILANTHROPIC SERVICES CONCERNING MONETARY DONATIONS TO SUPPORT AND BENEFIT THE ADVANCEMENT OF INTEGRATIVE MEDICINE (U.S. CLS. 100, 101 AND 102).

FIRST USE 4-0-2004; IN COMMERCE 4-0-2004.

CLASS 41—EDUCATION AND ENTERTAINMENT

FOR NON-DOWNLOADABLE ELECTRONIC PUBLICATIONS IN THE NATURE OF E-BOOKS, E-BOOKLETS AND E-NEWSLETTERS IN THE FIELD OF INTEGRATIVE MEDICINE; NON-DOWNLOADABLE ONLINE ELECTRONIC PUBLICATIONS IN THE NATURE OF NEWSLETTERS, PAMPHLETS, BOOKS, PAPERS, REPORTS AND STUDIES IN THE FIELD OF INTEGRATIVE MEDICINE; CHARITABLE SERVICES IN THE NATURE OF ORGANIZING STRATEGIC PARTNERSHIPS TO AID, SUPPORT AND PROMOTE THE ADVANCEMENT OF INTEGRATIVE MEDICINE, NAMELY, DEVELOPING EDUCATIONAL MEETINGS AND WORKSHOPS TO HELP EDUCATE AND INFORM OTHERS ABOUT THE CLINICAL AND COST BENEFITS OF INTEGRATIVE MEDICINE; NON-DOWNLOADABLE ELECTRONIC PUBLICATIONS IN THE NATURE OF DOCUMENTS IN THE FIELD OF INTEGRATIVE MEDICINE (U.S. CLS. 100, 101 AND 107).

FIRST USE 4-0-2004; IN COMMERCE 4-0-2004.

CLASS 42—SCIENTIFIC AND COMPUTER SERVICES

FOR PROVIDING SCIENTIFIC RESEARCH SERVICES IN THE FIELD OF INTEGRATIVE MEDICINE; PROVIDING SCIENTIFIC AND MEDICAL RESEARCH TO INCREASE THE KNOWLEDGE AND EVIDENCE BASED PRACTICE OF INTEGRATIVE MEDICINE (U.S. CLS. 100 AND 101).

FIRST USE 4-0-2004; IN COMMERCE 4-0-2004.

CLASS 44—MEDICAL, BEAUTY AND AGRICULTURAL SERVICES

FOR PROVIDING INFORMATION IN THE FIELD OF INTEGRATIVE MEDICINE; INFORMATION SERVICES, NAMELY, PROVIDING A WEBSITE FEATURING INFORMATION ABOUT THE FIELD OF INTEGRATIVE MEDICINE; PROVIDING INFORMATION IN THE FIELD OF HEALTH AWARENESS (U.S. CLS. 100 AND 101).

FIRST USE 4-4-2004; IN COMMERCE 4-4-2004.
TINA BROWN, EXAMINING ATTORNEY

SN 85-128,049. REFLECTIONS OF GRACE FOUNDATION, INC., IRWIN, PA. FILED 9-13-2010.

Reflections Of Grace Foundation

THE MARK CONSISTS OF STANDARD CHARACTERS WITHOUT CLAIM TO ANY PARTICULAR FONT, STYLE, SIZE, OR COLOR.

NO CLAIM IS MADE TO THE EXCLUSIVE RIGHT TO USE "FOUNDATION", APART FROM THE MARK AS SHOWN.

CLASS 35—ADVERTISING AND BUSINESS

FOR CHARITABLE SERVICES, NAMELY, ORGANIZING AND CONDUCTING EVENTS TO RAISE PUBLIC AWARENESS OF ALL TYPES OF PEDIATRIC BRAIN CANCERS (U.S. CLS. 100, 101 AND 102).

FIRST USE 1-0-2009; IN COMMERCE 1-0-2009.

CLASS 36—INSURANCE AND FINANCIAL

FOR CHARITABLE SERVICES, NAMELY, PROVIDING FINANCIAL SUPPORT TO CHILDREN AND FAMILIES AFFECTED BY PEDIATRIC BRAIN CANCER; AND CHARITABLE SERVICES, NAMELY, PROVIDING FUNDRAISING ACTIVITIES TO SUPPORT MEDICAL RESEARCH TO FIND A CURE FOR PEDIATRIC BRAIN CANCERS (U.S. CLS. 100, 101 AND 102).

FIRST USE 1-0-2009; IN COMMERCE 1-0-2009.

ANTHONY RINKER, EXAMINING ATTORNEY

SN 85-128,634. CYTORI THERAPEUTICS, INC., SAN DIEGO, CA. FILED 9-13-2010.

RESTORING LIVES

THE MARK CONSISTS OF STANDARD CHARACTERS WITHOUT CLAIM TO ANY PARTICULAR FONT, STYLE, SIZE, OR COLOR.

CLASS 1—CHEMICALS

FOR CHEMICAL PREPARATIONS, NAMELY, BIOLOGICALLY COMPATIBLE CHEMICAL SUBSTANCES FOR SCIENTIFIC, LABORATORY, CLINICAL AND MEDICAL RESEARCH (U.S. CLS. 1, 5, 6, 10, 26 AND 46).

CLASS 5—PHARMACEUTICALS

FOR IMPLANTABLE, INJECTABLE AND OTHER BIOLOGICAL USE PREPARATIONS COMPRISING OR DERIVED FROM STEM CELLS OR PROGENITOR CELLS FOR MEDICAL PURPOSES, NAMELY, REAGENTS COMPRISING NON-SYNTHETIC CELLULAR COMPOSITIONS FOR MEDICAL PURPOSES IN THE NATURE OF ENZYMES, PHARMACEUTICAL PREPARATIONS AND REAGENTS FOR PLACEMENT INTO CONTACT WITH THE MAMMALIAN BODY FOR THE TREATMENT OF SKIN, ORGAN AND TISSUE DISORDERS, DISEASES AND INJURIES AND FOR COSMETIC AND RECONSTRUCTIVE SURGERY (U.S. CLS. 6, 18, 44, 46, 51 AND 52).

CLASS 10—MEDICAL APPARATUS

FOR MEDICAL APPARATUS, INSTRUMENTS AND ARTICLES, NAMELY, MEDICAL INSTRUMENTS FOR PROCESSING, CONCENTRATING, AND IMPLANTING CELLS AND CELLULAR COMPOSITIONS; MEDICAL INSTRUMENTS FOR TISSUE, CELL, CELLULAR COMPONENTS AND STEM CELL EXTRACTION, PROCESSING AND APPLICATION; TISSUE AND CELL SEPARATION AND PURIFICATION DEVICES, NAMELY, DEVICES USED FOR THE ISOLATION OF CELLS AND CELLULAR COMPONENTS WITHIN ADIPOSE TISSUE FOR MEDICAL USE; TISSUE AND CELL PROCESSING DEVICES, NAMELY, DEVICES USED FOR THE COLLECTION AND STORAGE OF ADIPOSE TISSUE AND ADIPOSE TISSUE DERIVED CELLS FOR MEDICAL USE (U.S. CLS. 26, 39 AND 44).

CLASS 39—TRANSPORTATION AND STORAGE

FOR TRANSPORT, PACKAGING FOR TRANSPORT, AND STORAGE OF GOODS FOR SCIENTIFIC AND MEDICAL PURPOSES; STORAGE OF TISSUE, CELLS AND CELLULAR COMPONENTS FOR SCIENTIFIC AND MEDICAL PURPOSES; STORAGE OF HUMAN TISSUE, CELLS AND CELLULAR COMPONENTS FOR USE IN CELL AND CELLULAR COMPONENT TRANSPLANTATIONS AND TREATMENTS; ELECTRONIC AND PHYSICAL STORAGE OF PATIENT DATA STORAGE FOR SCIENTIFIC, MEDICAL AND BUSINESS PURPOSES; ELECTRONIC STORAGE OF BIOLOGICAL DATA; PHYSICAL STORAGE OF BIOLOGICAL MATERIALS (U.S. CLS. 100 AND 105).

CLASS 44—MEDICAL, BEAUTY AND AGRICULTURAL SERVICES

FOR MEDICAL SERVICES, COSMETIC AND RECONSTRUCTIVE SURGERY SERVICES PROVIDED BY THE MEMBERS OF PROFESSIONS SUCH AS MEDICAL DOCTORS AND SURGEONS AND RELATED ENTITIES FOR THE ANALYSIS AND TREATMENT OF COSMETIC AND OTHER HUMAN CONDITIONS AND DISEASES; MEDICAL TREATMENT AND MEDICAL SERVICES USING TISSUE, CELLS, CELLULAR COMPONENTS AND STEM CELLS FOR COSMETIC PURPOSES AND THE TREATMENT OF DISORDERS, DISEASES AND INJURIES (U.S. CLS. 100 AND 101).

NICHOLAS COLEMAN, EXAMINING ATTORNEY

CLASS 35—ADVERTISING AND BUSINESS

FOR ADVERTISING SERVICES; PROMOTING THE GOODS AND SERVICES OF OTHERS BY DISTRIBUTING ADVERTISING MATERIALS; CINEMA ADVERTISING; DISSEMINATION OF ADVERTISING FOR OTHERS VIA PUBLIC AND PRIVATE WIRELESS NETWORKS FOR DISPLAY ON MOBILE DEVICES; ADVERTISING VIA ELECTRONIC MEDIA AND SPECIFICALLY THE INTERNET; PROMOTING THE GOODS AND SERVICES OF OTHERS BY PROVIDING A WEBSITE FEATURING FACTS AND INFORMATION ABOUT AND RELATED TO MOTION PICTURES, TELEVISION AND ENTERTAINMENT EVENTS; PROMOTING THE GOODS AND SERVICES OF OTHERS BY PROVIDING LINKS TO THE WEBSITES OF OTHERS (U.S. CLS. 100, 101 AND 102).

FIRST USE 4-13-2010; IN COMMERCE 9-7-2010.

CLASS 41—EDUCATION AND ENTERTAINMENT

FOR PROVIDING INFORMATION, NEWS AND COMMENTARY IN THE FIELD OF ENTERTAINMENT, NAMELY, MOVIES AND CELEBRITIES; ENTERTAINMENT SERVICES IN THE FIELD OF FILM, MOVIES AND ENTERTAINMENT, NAMELY, PRODUCTION, EDITING AND DISTRIBUTION OF FILM CLIPS, MOVIE TRAILERS, NEWS ARTICLES, PHOTOGRAPHS AND OTHER MULTIMEDIA MATERIALS; ENTERTAINMENT SERVICES IN THE NATURE OF DEVELOPMENT, CREATION, PRODUCTION AND POST-PRODUCTION SERVICES OF MULTIMEDIA ENTERTAINMENT CONTENT; PROVIDING WEBSITES AND MOBILE MEDIA CONTENT IN THE NATURE OF NON-DOWNLOADABLE PHOTOGRAPHIC, AUDIO AND VIDEO PRESENTATIONS AND NON-DOWNLOADABLE VIDEOS FEATURING ENTERTAINMENT INFORMATION; ENTERTAINMENT SERVICES, NAMELY, PROVIDING WEBSITES AND MOBILE MEDIA CONTENT IN THE NATURE OF NON-DOWNLOADABLE PHOTOGRAPHIC, AUDIO AND VIDEO PRESENTATIONS AND NON-DOWNLOADABLE VIDEOS FEATURING NON-DOWNLOADABLE FILM CLIPS, MOVIE TRAILERS, PHOTOGRAPHS, MUSIC AND MULTIMEDIA MATERIALS ALL IN THE FIELD OF ENTERTAINMENT; PROVIDING INTERNET WEBSITES IN THE FIELD OF MOVIES AND ENTERTAINMENT; PROVIDING WEBSITES FEATURING ENTERTAINMENT INFORMATION; ENTERTAINMENT SERVICES, NAMELY, PROVIDING ON-LINE REVIEWS, RATINGS AND RECOMMENDATIONS FOR MOVIES AND FILMS; PROVIDING ON-LINE INFORMATION IN THE FIELD ENTERTAINMENT VIA THE INTERNET AND MOBILE COMMUNICATION DEVICES; MOVIE THEATER AND MOVIE SCHEDULE AND LOCATION INFORMATION SERVICES; PROVIDING INFORMATION, NEWS AND COMMENTARY IN THE FIELD OF ENTERTAINMENT (U.S. CLS. 100, 101 AND 107).

FIRST USE 4-13-2010; IN COMMERCE 9-7-2010.

SN 85-128,958, NATIONAL CINEMEDIA, LLC, CENTENNIAL, CO. FILED 9-14-2010.

MOVIE NIGHT OUT

THE MARK CONSISTS OF STANDARD CHARACTERS WITHOUT CLAIM TO ANY PARTICULAR FONT, STYLE, SIZE, OR COLOR.

NO CLAIM IS MADE TO THE EXCLUSIVE RIGHT TO USE "MOVIE", APART FROM THE MARK AS SHOWN.

CLASS 9—ELECTRICAL AND SCIENTIFIC APPARATUS

FOR DOWNLOADABLE COMPUTER SOFTWARE APPLICATIONS ENABLING USERS TO POST, SHARE, STORE AND LINK CONTENT IN THE FIELD OF MOVIES, CELEBRITY AND ENTERTAINMENT NEWS; DOWNLOADABLE MEDIA, NAMELY, VIDEOS, AUDIO FILES, COMPUTER SOFTWARE APPLICATIONS ENABLING USERS TO POST, SHARE, STORE AND LINK CONTENT, AND WIDGETS IN THE NATURE OF SOFTWARE APPLICATIONS ENABLING USERS TO POST, SHARE, STORE AND LINK CONTENT, ALL FEATURING RICH MEDIA ENTERTAINMENT; MOBILE MEDIA CONTENT IN THE NATURE OF DOWNLOADABLE AUDIO AND VIDEO RECORDINGS FEATURING ENTERTAINMENT INFORMATION; DOWNLOADABLE MOBILE MEDIA CONTENT IN THE NATURE OF PHOTOGRAPHIC, AUDIO AND VIDEO PRESENTATIONS FEATURING DOWNLOADABLE FILM CLIPS, MOVIE TRAILERS, PHOTOGRAPHS, MUSIC AND MULTIMEDIA MATERIALS ALL IN THE FIELD OF ENTERTAINMENT (U.S. CLS. 21, 23, 26, 36 AND 38).

FIRST USE 4-13-2010; IN COMMERCE 9-7-2010.

CLASS 42—SCIENTIFIC AND COMPUTER SERVICES

FOR COMPUTER SERVICES, NAMELY, HOSTING ON-LINE INTERACTIVE WEBSITE FEATURING ENTERTAINMENT INFORMATION, ON-LINE INTERACTIVE PUBLIC CALENDARS, AND ELECTRONIC MAPS, THAT ALLOWS MULTIPLE PARTICIPANTS TO SHARE ENTERTAINMENT EVENT INFORMATION, EVENT SCHEDULES AND EVENT LOCATIONS; PROVIDING A WEBSITE FEATURING TEMPORARY USE OF NON-DOWNLOADABLE SOFTWARE ALLOWING USERS TO DYNAMICALLY SEARCH AND BROWSE THROUGH MOVIES TO VIEW INFORMATION IN THE FIELD OF MOVIES AND ENTERTAINMENT; COMPUTER SERVICES, NAMELY, CREATING AN ON-LINE COMMUNITY FOR REGISTERED USERS TO SHARE ENTERTAINMENT INFORMATION, PARTICIPATE IN DISCUSSIONS, GET FEEDBACK FROM THEIR PEERS, AND ENGAGE IN SOCIAL NETWORKING; PROVIDING A WEBSITE THROUGH WHICH USERS ARE ABLE TO SELECT, MANAGE AND DOWNLOAD DIGITAL MEDIA CONTENT FROM THE INTERNET DIRECTLY TO COMPUTERS, MEDIA PLAYERS AND MOBILE DEVICES (U.S. CLS. 100 AND 101).

FIRST USE 4-13-2010; IN COMMERCE 9-7-2010.

HEATHER THOMPSON, EXAMINING ATTORNEY

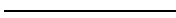

SN 85-129,148. JASON INCORPORATED, CLEVELAND, OH. FILED 9-14-2010.

XTRASEAL

THE MARK CONSISTS OF STANDARD CHARACTERS WITHOUT CLAIM TO ANY PARTICULAR FONT, STYLE, SIZE, OR COLOR.

CLASS 17—RUBBER GOODS

FOR PRIMARILY NONMETALLIC WEATHER STRIPPING BRUSHES FOR INSULATING, SEALING, PROVIDING BARRIERS, AND SHIELDING (U.S. CLS. 1, 5, 12, 13, 35 AND 50).
FIRST USE 2-14-2003; IN COMMERCE 2-14-2003.

CLASS 21—HOUSEWARES AND GLASS

FOR BRUSHES FOR CLEANING, SCRAPING, ABRADING AND WIPING (U.S. CLS. 2, 13, 23, 29, 30, 33, 40 AND 50).
FIRST USE 2-14-2003; IN COMMERCE 2-14-2003.
ADA HAN, EXAMINING ATTORNEY



SN 85-129,619. BRAVOD TECHNOLOGY CORPORATION, HSINCHU CITY, TAIWAN, FILED 9-14-2010.

braVod

THE MARK CONSISTS OF THE LETTERS "BRA" IN LOWERCASE, THE LETTER "V" IN UPPERCASE, FOLLOWED BY THE LETTERS "OD" IN LOWERCASE. THE WORDING "BRAVOD" HAS NO MEANING IN A FOREIGN LANGUAGE.

CLASS 9—ELECTRICAL AND SCIENTIFIC APPARATUS

FOR ELECTRICAL AND SCIENTIFIC APPARATUS, NAMELY, COMPUTER WHITEBOARDS; COMPUTER JOYSTICKS; PERSONAL COMPUTERS; DESKTOP COMPUTERS; HAND-HELD ELECTRONIC COMPUTERS; LAPTOP COMPUTERS; LIQUID CRYSTAL DISPLAYS (LCDS) FOR USE IN MONITORS; COMPUTER MOUSE DEVICES; LIGHT PENS; FINGERPRINT RECOGNITION DEVICES FOR USE IN COMPUTER SECURITY; PERSONAL DIGITAL ASSISTANTS; ELECTRONIC BOOKS FEATURING DIGITAL PAINTING AND DRAWING RECORDED ON COMPUTER MEDIA; HAND-HELD ELECTRONIC DICTIONARIES; TABLET COMPUTERS; DIGITAL PLOTTERS; COMPUTER TOUCH SENSITIVE INPUT DEVICES, NAMELY, TOUCH PADS; DIGITAL ELECTRONIC PENS (U.S. CLS. 21, 23, 26, 36 AND 38).

CLASS 16—PAPER GOODS AND PRINTED MATTER

FOR PAPER GOODS AND PRINTED MATTER, NAMELY, MANUALS IN THE FIELD OF TOUCH PAD AND TABLET COMPUTERS; OPERATION MANUALS IN THE FIELD OF TOUCH PAD AND TABLET COMPUTERS; INSTRUCTION MANUALS IN THE FIELD OF TOUCH PAD AND TABLET COMPUTERS; ADVERTISING MANUALS; WORKBOOKS DIRECTED TO TOUCH PAD AND TABLET COMPUTERS; SERVICE MANUALS IN THE FIELD OF TOUCH PAD AND TABLET COMPUTERS; TRAINING MANUALS IN THE FIELD OF TOUCH PAD AND TABLET COMPUTERS (U.S. CLS. 2, 5, 22, 23, 29, 37, 38 AND 50).

CLASS 35—ADVERTISING AND BUSINESS

FOR PLANNING, DESIGN, DEVELOPMENT, MAINTENANCE, TRACKING AND REPORTING OF ONLINE MARKETING ACTIVITIES AND DATABASE MANAGEMENT FOR THIRD PARTIES; MARKETING, ADVERTISING, AND PROMOTING THE RETAIL GOODS AND SERVICES OF OTHERS TO COMPUTER-RELATED ELECTRONIC DEVICES (U.S. CLS. 100, 101 AND 102).

CLASS 42—SCIENTIFIC AND COMPUTER SERVICES

FOR COMPUTER AND SCIENTIFIC SERVICES, NAMELY, DEVELOPMENT AND CREATION OF COMPUTER PROGRAMS FOR DATA PROCESSING AND DIGITAL IMAGE PROCESSING; NEW PRODUCT DESIGN SERVICES (U.S. CLS. 100 AND 101).
MICHAEL WEBSTER, EXAMINING ATTORNEY



SN 85-129,642. INTERSECTIONS INC., CHANTILLY, VA. FILED 9-14-2010.

iDcheckup

NO CLAIM IS MADE TO THE EXCLUSIVE RIGHT TO USE "ID", APART FROM THE MARK AS SHOWN. THE MARK CONSISTS OF THE LETTERS "ID" AND THE WORD "CHECKUP" WITH A CHECK MARK DESIGN SERVING TO FORM THE LETTER "U" IN "CHECKUP".

CLASS 9—ELECTRICAL AND SCIENTIFIC APPARATUS

FOR (BASED ON INTENT TO USE) COMPUTER SOFTWARE AND DOWNLOADABLE COMPUTER SOFTWARE FOR IDENTITY THEFT AND FRAUD PROTECTION (U.S. CLS. 21, 23, 26, 36 AND 38).

SN 85-129,834. TIPTAP, INC., CAMBRIDGE, MA. FILED 9-15-2010.

CLASS 35—ADVERTISING AND BUSINESS

FOR (BASED ON USE IN COMMERCE) MONITORING CONSUMER CREDIT REPORTS; CREDIT CARD REGISTRATION SERVICES; CREDIT CARD CANCELLATION SERVICES FOR LOST OR STOLEN CARDS; CREDIT CARD MONITORING SERVICES FOR LOST OR STOLEN CARDS (U.S. CLS. 100, 101 AND 102).

FIRST USE 1-29-2010; IN COMMERCE 1-29-2010.

TIPTAP

CLASS 36—INSURANCE AND FINANCIAL

FOR (BASED ON USE IN COMMERCE) PROVIDING IDENTITY THEFT INSURANCE UNDERWRITTEN BY OTHERS; PROVIDING CREDIT REPORTING DATA MAINTAINED BY OTHERS; OBTAINING CREDIT INFORMATION AND OTHER PUBLIC AND PERSONAL FINANCIAL INFORMATION FOR USE IN PROVIDING REPORTS ON CREDIT RISKS DUE TO IDENTITY THEFT; CREDIT MANAGEMENT SERVICES, NAMELY, ASSISTANCE WITH RESTORING CREDIT DAMAGED BY IDENTITY THEFT (U.S. CLS. 100, 101 AND 102).

FIRST USE 1-29-2010; IN COMMERCE 1-29-2010.

THE MARK CONSISTS OF STANDARD CHARACTERS WITHOUT CLAIM TO ANY PARTICULAR FONT, STYLE, SIZE, OR COLOR.

CLASS 35—ADVERTISING AND BUSINESS

FOR PROVIDING A WEB SITE WHERE USERS CAN POST RATINGS, REVIEWS AND RECOMMENDATIONS ON PRODUCTS AND SERVICES, AND BE PAID FOR THEIR CONTRIBUTIONS, FOR COMMERCIAL PURPOSES (U.S. CLS. 100, 101 AND 102).

FIRST USE 6-30-2010; IN COMMERCE 6-30-2010.

CLASS 39—TRANSPORTATION AND STORAGE

FOR (BASED ON USE IN COMMERCE) PROVIDING ONLINE SECURE ELECTRONIC STORAGE AND RETRIEVAL OF DIGITAL CONTENT, MEDIA AND IMAGES, NAMELY, PASSWORDS, PINS, ACCOUNT NUMBERS, MEDICAL RECORDS AND PRESCRIPTIONS, IMPORTANT DOCUMENTS, EMERGENCY CONTACT, DIGITAL PHOTOGRAPHS AND DIARIES FOR OTHERS (U.S. CLS. 100 AND 105).

FIRST USE 1-29-2010; IN COMMERCE 1-29-2010.

CLASS 38—COMMUNICATION

FOR PROVIDING AN ONLINE FORUM FOR GATHERING INFORMATION ON PRODUCTS AND SERVICES FROM OTHER PARTICIPANTS WHO CAN BE COMPENSATED FOR THEIR CONTRIBUTIONS (U.S. CLS. 100, 101 AND 104).

FIRST USE 6-30-2010; IN COMMERCE 6-30-2010.

HOWARD B. LEVINE, EXAMINING ATTORNEY

CLASS 45—PERSONAL AND LEGAL SERVICES

FOR (BASED ON USE IN COMMERCE) IDENTITY THEFT PROTECTION AND IDENTITY FRAUD PROTECTION SERVICES, NAMELY, PERSONAL INFORMATION AND FINANCIAL IDENTITY MONITORING; FRAUD RESOLUTION ASSISTANCE, NAMELY, PROVIDING ADVICE AND CONSULTATION IN THE FIELD OF IDENTITY THEFT AND DATA THEFT; IDENTITY THEFT AND FRAUD PROTECTION SERVICES, NAMELY, INTERNET SURVEILLANCE OF FINANCIAL AND PERSONAL INFORMATION; MONITORING THE INTERNET, PUBLIC RECORDS, PRIVATE AND PUBLIC ELECTRONIC DATABASES TO FACILITATE THE DETECTION AND PREVENTION OF IDENTITY THEFT AND FRAUD; PROVIDING ONLINE RESOURCES IN THE FIELD OF IDENTITY THEFT PROTECTION; PROVIDING A SECURE INTERACTIVE WEBSITE CONCERNING NOTIFICATIONS OF POTENTIAL FRAUD AND POTENTIAL IDENTITY THEFT; FRAUD DETECTION AND PREVENTION SERVICES IN THE NATURE OF ARRANGING SECURE AUTHENTICATION OF PERSONAL DATA IN REQUESTS TO OPEN BANKING, CREDIT, CREDIT CARD, INSURANCE, LOAN, AND OTHER FINANCIAL ACCOUNTS (U.S. CLS. 100 AND 101).

FIRST USE 1-29-2010; IN COMMERCE 1-29-2010.
EDWARD NELSON, EXAMINING ATTORNEY

SN 85-129,882. DC SAFETY SALES CO., INC., HAUPPAUGE, NY. FILED 9-15-2010.

THE MARK CONSISTS OF A CHECK MARK INSIDE A KIT NEXT TO THE STYLIZED WORDS "READY NOW".

CLASS 5—PHARMACEUTICALS

FOR FIRST AID KITS; EMERGENCY PREPAREDNESS KITS COMPRISING FIRST AID KITS AND FIRST AID SUPPLIES, NAMELY, ADHESIVE BANDAGES, GAUZE, MEDICAL ADHESIVE TAPE, MEDICATIONS, COTTON, HEMOSTATIC AGENTS, GLOVES, CPR AIDS, WOUND CLEANSERS, ANIMAL STING AND BITE RELIEF PREPARATIONS, SCISSORS, TWEEZERS, THERMOMETERS, COLD PACKS, OXYGEN SUPPLIES, AND SPLINTS, FOOD RATIONS, NAMELY, FOOD BARS, NUTRITION BARS, WATER, FRUIT DRINKS AND ELECTROLYTE REPLACEMENTS, EMERGENCY SHELTER SUPPLIES, NAMELY, PLASTIC SHEETING, ADHESIVE TAPE, ROPE, STORAGE CONTAINERS, ELECTRICITY GENERATOR, BATTERIES, AND EMERGENCY TOILETS, SURVIVAL SUPPLIES, NAMELY, WATER PURIFICATION UNITS, FIRE STARTERS, HAND TOOLS, EMERGENCY LIGHTS, RADIOS AND SIGNALING DEVICES; AUTO SAFETY KITS COMPRISING FIRST AID KITS, FIRST AID SUPPLIES, VEHICLE REPAIR TOOLS AND SUPPLIES, NAMELY, HAND OPERATED SCREWDRIVERS, WRENCHES, HOSE TAPE, JUMPER CABLES, FUSES, FLASHLIGHT, AIR COMPRESSORS, TIRE SEALANT, TIE STRAPS AND SAFETY SUPPLIES, NAMELY, REFLECTIVE VEST, WARNING FLAGS, LIGHT REFLECTORS, EMERGENCY WARNING DEVICES, EMERGENCY LIGHTS, FLARES; BICYCLE SAFETY KITS COMPRISING FIRST AID KITS, BICYCLE REPAIR TOOLS AND SUPPLIES, NAMELY, HAND OPERATED SCREWDRIVERS, WRENCHES, TIRE REPAIR TOOLS AND PATCHES; CHILDREN'S TRAVEL KITS COMPRISING FIRST AID KITS, SOAP, DISINFECTANTS, TOWELETTS, TOYS, GAMES, BOOKS, CRAYONS; PET TRAVEL KITS COMPRISING ANIMAL FIRST AID KITS, FIRST AID SUPPLIES, NAMELY, ADHESIVE BANDAGES, GAUZE, MEDICAL ADHESIVE TAPE, MEDICATIONS, HEMOSTATIC AGENTS, WOUND CLEANSERS, SPLINTS, CLEANING PREPARATIONS, SEAT COVER AND FLOOR MAT, LEASH, RESTRAINT FOR VEHICLE SEATS, VEST, COLLAR (U.S. CLS. 6, 18, 44, 46, 51 AND 52).

CLASS 8—HAND TOOLS

FOR ROADSIDE EMERGENCY KITS COMPRISING VEHICLE REPAIR TOOLS AND SUPPLIES, NAMELY, HAND OPERATED SCREWDRIVERS, HAND OPERATED WRENCHES, HOSE TAPE, JUMPER CABLES, FUSES, FLASHLIGHT, TIE STRAPS, AIR COMPRESSORS, TIRE SEALANT, AND SAFETY SUPPLIES, NAMELY, REFLECTIVE VEST, WARNING FLAGS, LIGHT REFLECTORS, EMERGENCY WARNING DEVICES, EMERGENCY LIGHTS, FLARES (U.S. CLS. 23, 28 AND 44).

KIM SAITO, EXAMINING ATTORNEY

SN 85-129,949. THOMASVILLE HOME FURNISHINGS, INC., THOMASVILLE, NC. FILED 9-15-2010.

THOMASVILLE

THE MARK CONSISTS OF STANDARD CHARACTERS WITHOUT CLAIM TO ANY PARTICULAR FONT, STYLE, SIZE, OR COLOR.

OWNER OF U.S. REG. NOS. 1,151,730, 3,141,739 AND OTHERS.
SEC. 2(F).

CLASS 2—PAINTS

FOR WOOD PRESERVING OILS AND/OR OILS FOR USE AS PROTECTIVE COATINGS FOR WOOD (U.S. CLS. 6, 11 AND 16).

CLASS 3—COSMETICS AND CLEANING PREPARATIONS

FOR WOOD CARE POLISHES, CREAMS, AND CLEANERS (U.S. CLS. 1, 4, 6, 50, 51 AND 52).

CLASS 6—METAL GOODS

FOR METAL SHUTTERS (U.S. CLS. 2, 12, 13, 14, 23, 25 AND 50).

CLASS 19—NON-METALLIC BUILDING MATERIALS

FOR NON-METAL SHUTTERS (U.S. CLS. 1, 12, 33 AND 50).

REGINA DRUMMOND, EXAMINING ATTORNEY

SN 85-129,968. THOMASVILLE HOME FURNISHINGS, INC., THOMASVILLE, NC. FILED 9-15-2010.

Thomasville

OWNER OF U.S. REG. NOS. 1,151,730, 3,141,739 AND OTHERS.

THE MARK CONSISTS OF THE WORD "THOMASVILLE" WRITTEN IN A STYLIZED FORMAT.
SEC. 2(F).

CLASS 2—PAINTS

FOR WOOD PRESERVING OILS AND/OR OILS FOR USE AS PROTECTIVE COATINGS FOR WOOD (U.S. CLS. 6, 11 AND 16).

CLASS 3—COSMETICS AND CLEANING PREPARATIONS

FOR WOOD CARE POLISHES, CREAMS, AND CLEANERS (U.S. CLS. 1, 4, 6, 50, 51 AND 52).

CLASS 6—METAL GOODS

FOR METAL SHUTTERS (U.S. CLS. 2, 12, 13, 14, 23, 25 AND 50).

CLASS 19—NON-METALLIC BUILDING MATERIALS

FOR NON-METAL SHUTTERS (U.S. CLS. 1, 12, 33 AND 50).

REGINA DRUMMOND, EXAMINING ATTORNEY

SN 85-131,000. MITCHELL COMMUNICATIONS GROUP, FAYETTEVILLE, AR. FILED 9-16-2010.

MITCHELL COMMUNICATIONS GROUP

THE MARK CONSISTS OF STANDARD CHARACTERS WITHOUT CLAIM TO ANY PARTICULAR FONT, STYLE, SIZE, OR COLOR.

NO CLAIM IS MADE TO THE EXCLUSIVE RIGHT TO USE "COMMUNICATIONS GROUP", APART FROM THE MARK AS SHOWN.

CLASS 35—ADVERTISING AND BUSINESS

FOR PUBLIC RELATIONS SERVICES; BUSINESS STRATEGIC PLANNING IN THE FIELD OF MEDIA RELATIONS; BUSINESS STRATEGIC PLANNING CONSULTATION SERVICES IN THE FIELD OF REPUTATION MANAGEMENT, CRISIS MANAGEMENT, CRISIS COMMUNICATIONS, CORPORATE COMMUNICATIONS, CORPORATE SOCIAL RESPONSIBILITY, AND EMPLOYEE COMMUNICATIONS; BUSINESS MARKETING CONSULTING IN THE FIELD OF CONSUMER RELATIONS, PRODUCT PROMOTION, BRAND DEVELOPMENT, POSITIONING AND MANAGEMENT, AND CONTENT CREATION (U.S. CLS. 100, 101 AND 102).

FIRST USE 1-30-2001, THE MARK WAS FIRST USED ANYWHERE IN A DIFFERENT FORM OTHER THAN THAT SOUGHT TO BE REGISTERED AT LEAST AS EARLY AS 00/00/1995. ; IN COMMERCE 1-30-2001, THE MARK WAS FIRST USED IN COMMERCE IN A DIFFERENT FORM OTHER THAN THAT SOUGHT TO BE REGISTERED AT LEAST AS EARLY AS 00/00/1995..

CLASS 42—SCIENTIFIC AND COMPUTER SERVICES

FOR GRAPHIC DESIGN SERVICES; WEBSITE DESIGN AND DEVELOPMENT FOR OTHERS; COMPUTER SERVICES, NAMELY, DESIGNING SOCIAL MEDIA PLATFORMS AND COMPUTER PROGRAMMING SERVICES, NAMELY, CONTENT CREATION FOR SOCIAL MEDIA NETWORKS AND VIRTUAL COMMUNITIES (U.S. CLS. 100 AND 101).

FIRST USE 1-30-2001; IN COMMERCE 1-30-2001. ASMAT KHAN, EXAMINING ATTORNEY

SN 85-131,201. VICEROY HOTELS, L.L.C., LOS ANGELES, CA. FILED 9-16-2010.

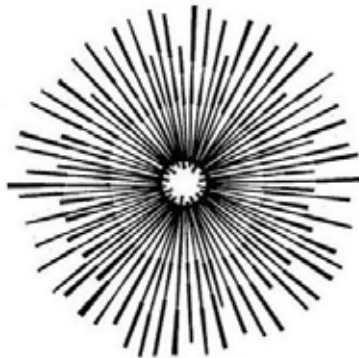

THE MARK CONSISTS OF SUNBURST.

CLASS 35—ADVERTISING AND BUSINESS

FOR HOTEL MANAGEMENT FOR OTHERS (U.S. CLS. 100, 101 AND 102). FIRST USE 4-0-2006; IN COMMERCE 4-0-2006.

CLASS 36—INSURANCE AND FINANCIAL

FOR REAL ESTATE AGENCY SERVICES; LEASING OF REAL ESTATE; REAL ESTATE MANAGEMENT; REAL ESTATE AND CONDOMINIUM LISTING AND BROKERAGE SERVICES (U.S. CLS. 100, 101 AND 102). FIRST USE 4-0-2006; IN COMMERCE 4-0-2006.

CLASS 43—HOTEL AND RESTAURANT SERVICES

FOR HOTEL AND RESORT LODGING SERVICES; PROVISION OF GENERAL PURPOSE FACILITIES FOR MEETINGS, CONFERENCES AND EXHIBITIONS; RESERVATION SERVICES FOR HOTEL ROOM ACCOMMODATIONS; RESTAURANT AND BAR SERVICES (U.S. CLS. 100 AND 101).

FIRST USE 4-0-2006; IN COMMERCE 4-0-2006. H. M. FISHER, EXAMINING ATTORNEY

SN 85-131,259. RICOS INTELLECTUAL PROPERTY, LTD., SAN ANTONIO, TX. FILED 9-16-2010.



THE MARK CONSISTS OF DESIGN OF ENLARGED BARCODE IN SHAPE OF ALAMO.

CLASS 29—MEATS AND PROCESSED FOODS

FOR MEATS AND PROCESSED FOODS, NAMELY, CHILI WITH BEANS, PROCESSED JALAPENO PEPPERS, PICKLES, CHEESE, NAMELY, PROCESSED CHEDDAR CHEESE; BUTTER, PROCESSED OILS FOR FOOD, FRIED MEAT, NAMELY, FRIED PORK RINDS, ROASTED PEANUTS (U.S. CL. 46).

CLASS 30—STAPLE FOODS

FOR STAPLE FOODS, NAMELY, TORTILLA CHIPS, NACHOS, POPCORN; FLAVOR-COATED POPPED POPCORN, CORN-BASED SNACK FOODS (U.S. CL. 46). RAMONA ORTIGA, EXAMINING ATTORNEY

SN 85-131,288. RAINBOW MAX FOR GIFTS, ACCESSORIES & WATCHES, HAWALLI 32020, KUWAIT, FILED 9-16-2010.



THE MARK CONSISTS OF A REPRESENTATION OF A CAT WITH A RIBBON ON ITS TAIL AND A LOCKET AROUND ITS NECK.

CLASS 16—PAPER GOODS AND PRINTED MATTER

FOR PAPER, CARDBOARD; STATIONERY; ERASERS; COPYBOOKS; NOTEBOOKS; DRAWING BOOKS, NAMELY, COLORING BOOKS; COLORING PENS; ADHESIVE MATERIALS USED FOR STATIONERY AND ARTIST'S MATERIALS; ARTISTS MATERIALS, NAMELY, PAINT BRUSHES; PLASTIC MATERIALS FOR PACKAGING, NAMELY, BAGS FOR MERCHANDISE; STAMPS, NAMELY, RUBBER STAMP, INK STAMP AND PRINT LETTERS; PENCIL CASES; BAGS FOR PENS AND PENCILS, NAMELY, PENCIL OR PEN BOXES (U.S. CLS. 2, 5, 22, 23, 29, 37, 38 AND 50).

CLASS 18—LEATHER GOODS

FOR LEATHER AND IMITATIONS OF LEATHER; ANIMAL SKINS AND HIDES; TRUNKS AND TRAVELING BAGS; UMBRELLAS; PARASOLS AND WALKING STICKS; WHIPS; HARNESS AND SADDLERY; ALL TYPES OF SCHOOL BAGS; TRAVEL BAGS; SPORTS BAGS WITH FABRIC AND LEATHER MATERIAL (U.S. CLS. 1, 2, 3, 22 AND 41).

NAKIA HENRY, EXAMINING ATTORNEY

SN 85-131,333. RAINBOW MAX FOR GIFTS, ACCESSORIES & WATCHES, HAWALLI 32020, KUWAIT, FILED 9-16-2010.



THE MARK CONSISTS OF THE WORDING "LULU CATY" AND A RIBBON TIED IN A BOW.

CLASS 16—PAPER GOODS AND PRINTED MATTER

FOR PAPER, CARDBOARD; STATIONERY; ERASERS; COPYBOOKS; NOTEBOOKS; DRAWING BOOKS, NAMELY, COLORING BOOKS; COLORING PENS; ADHESIVE MATERIALS USED FOR STATIONERY AND ARTIST'S MATERIALS; ARTISTS MATERIALS, NAMELY, PAINT BRUSHES; PLASTIC MATERIALS FOR PACKAGING, NAMELY, BAGS FOR MERCHANDISE; STAMPS, NAMELY, RUBBER STAMP, INK STAMP AND PRINT LETTERS; PENCIL CASES; BAGS FOR PENS AND PENCILS, NAMELY, PENCIL OR PEN BOXES (U.S. CLS. 2, 5, 22, 23, 29, 37, 38 AND 50).

CLASS 18—LEATHER GOODS

FOR LEATHER AND IMITATIONS OF LEATHER; ANIMAL SKINS AND HIDES; TRUNKS AND TRAVELING BAGS; UMBRELLAS; PARASOLS AND WALKING STICKS; WHIPS; HARNESS AND SADDLERY; ALL TYPES OF SCHOOL BAGS; TRAVEL BAGS; SPORTS BAGS WITH FABRIC AND LEATHER MATERIAL (U.S. CLS. 1, 2, 3, 22 AND 41).

NAKIA HENRY, EXAMINING ATTORNEY

SN 85-131,696. CULINARY ENTERTAINMENT, INC., GUAYNABO, PUERTO RICO, FILED 9-16-2010.



THE COLOR(S) SHOCKING PINK, GREEN, RED, BLUE, YELLOW AND BLACK IS/ARE CLAIMED AS A FEATURE OF THE MARK.

THE MARK CONSISTS OF THE LETTER "B" IN BLUE, FOLLOWED BY A YELLOW DOT, FOLLOWED BY THE WORD "PETIT" WITH EACH LETTER IN THE FOLLOWING COLORS: SHOCKING PINK, GREEN, BLUE, RED, AND YELLOW AND ALL WITH BLACK SHADING.

THE ENGLISH TRANSLATION OF "PETIT" IN THE MARK IS SMALL.

CLASS 35—ADVERTISING AND BUSINESS

FOR ADVERTISING AND DIRECTORY SERVICES, NAMELY, PROMOTING THE SERVICES OF OTHERS BY PROVIDING A WEB PAGE FEATURING LINKS TO THE WEBSITES OF OTHERS; PROVIDING A SEARCHABLE WEBSITE FEATURING THE GOODS AND SERVICES OF OTHER VENDORS; PROVIDING A WEBSITE USED TO PLACE ON-LINE COMMERCIAL ORDERS IN THE FIELD OF CHILDREN'S PRODUCTS, CHILDREN'S TOYS, CHILDREN'S CLOTHES, AND CHILDREN'S ACCESSORIES; PROVISION OF SPACE ON WEBSITES FOR ADVERTISING GOODS AND SERVICES (U.S. CLS. 100, 101 AND 102).

CLASS 41—EDUCATION AND ENTERTAINMENT

FOR ENTERTAINMENT SERVICES, NAMELY, PROVIDING A WEBSITE FEATURING GAMES AND PUZZLES; PROVIDING A WEBSITE FEATURING INFORMATION IN THE FIELDS OF EDUCATION AND ENTERTAINMENT FOR CHILDREN; PROVIDING A WEBSITE FEATURING RESOURCES, NAMELY, NON-DOWNLOADABLE PUBLICATIONS IN THE NATURE OF MAGAZINES AND NEWSLETTERS IN THE FIELD OF CHILDREN'S ENTERTAINMENT AND TOYS, CHILDREN'S WELL-BEING, AND THE ENVIRONMENT FOR CHILDREN (U.S. CLS. 100, 101 AND 107).

TASNEEM HUSSAIN, EXAMINING ATTORNEY

SN 85-132,279. SUMMER INFANT (USA), INC., WOONSOCKET, RI. FILED 9-17-2010.

SN 85-132,650. UFI FILTERS S.P.A., PORTO MANTOVANO, ITALY, FILED 9-17-2010.

Travel Pals

THE MARK CONSISTS OF STANDARD CHARACTERS WITHOUT CLAIM TO ANY PARTICULAR FONT, STYLE, SIZE, OR COLOR.

NO CLAIM IS MADE TO THE EXCLUSIVE RIGHT TO USE "TRAVEL", APART FROM THE MARK AS SHOWN.

CLASS 12—VEHICLES

FOR MIRRORS FOR VEHICLES, NAMELY, REAR-VIEW CHILD OBSERVATION MIRRORS (U.S. CLS. 19, 21, 23, 31, 35 AND 44).

CLASS 26—FANCY GOODS

FOR CHILD RESTRAINING DEVICES IN THE NATURE OF HARNESSSES; TETHERS FOR CHILD HARNESSSES; HARNESSSES FOR GUIDING CHILDREN (U.S. CLS. 37, 39, 40, 42 AND 50).

APRIL HESIK, EXAMINING ATTORNEY

SN 85-132,304. H. HUNTSMAN & SONS LIMITED, LONDON, UNITED KINGDOM, FILED 9-17-2010.

HUNTSMAN

THE MARK CONSISTS OF STANDARD CHARACTERS WITHOUT CLAIM TO ANY PARTICULAR FONT, STYLE, SIZE, OR COLOR.

OWNER OF U.S. REG. NO. 1,139,970.

CLASS 24—FABRICS

FOR TEXTILE FABRICS FOR THE MANUFACTURE OF CLOTHING (U.S. CLS. 42 AND 50).

CLASS 25—CLOTHING

FOR CLOTHING, NAMELY, SHIRTS, TIES, POCKET SQUARES, SCARVES, BRACES, BELTS, SUITS, JACKETS, AND PANTS; FOOTWEAR; HEADGEAR, NAMELY, HATS AND CAPS (U.S. CLS. 22 AND 39).

FIRST USE 10-0-1946; IN COMMERCE 12-0-1947.

CLASS 40—MATERIAL TREATMENT

FOR TAILORING (U.S. CLS. 100, 103 AND 106).
FIRST USE 0-0-1849; IN COMMERCE 12-0-1947.
DARRYL SPRUILL, EXAMINING ATTORNEY



PRIORITY CLAIMED UNDER SEC. 44(D) ON ITALY APPLICATION NO. RE2010C00032, FILED 9-1-2010, REG. NO. 1440049, DATED 3-29-2011, EXPIRES 9-1-2020.

THE MARK CONSISTS OF THE WORD "SOFIMA" IN A STYLIZED FONT IN A VERTICAL POSITION WITH THE DESIGN OF A RHINOCEROS TO THE RIGHT OF THE WORDING.

THE WORDING "SOFIMA" HAS NO MEANING IN A FOREIGN LANGUAGE.

CLASS 1—CHEMICALS

FOR CHEMICAL PREPARATIONS IN THE NATURE OF FILTERING MATERIALS TO BE USED IN THE AUTOMOTIVE INDUSTRY, BUS TRANSPORTATION INDUSTRY, TRANSPORTATION INDUSTRY, AERONAUTIC INDUSTRY, FOOD AND BEVERAGE INDUSTRY; UNPROCESSED PLASTICS IN THE NATURE OF FILTERING MATERIALS TO BE USED IN THE AUTOMOTIVE INDUSTRY, BUS TRANSPORTATION INDUSTRY, TRANSPORTATION INDUSTRY, AERONAUTIC INDUSTRY, FOOD AND BEVERAGE INDUSTRY; MINERAL SUBSTANCES IN THE NATURE OF FILTERING MATERIALS TO BE USED IN THE AUTOMOTIVE INDUSTRY, BUS TRANSPORTATION INDUSTRY, TRANSPORTATION INDUSTRY, AERONAUTIC INDUSTRY, FOOD AND BEVERAGE INDUSTRY; VEGETABLE SUBSTANCES IN THE NATURE OF FILTERING MATERIALS TO BE USED IN THE AUTOMOTIVE INDUSTRY, BUS TRANSPORTATION INDUSTRY, TRANSPORTATION INDUSTRY, AERONAUTIC INDUSTRY, FOOD AND BEVERAGE INDUSTRY (U.S. CLS. 1, 5, 6, 10, 26 AND 46).

CLASS 7—MACHINERY

FOR FILTERS FOR MACHINES, ENGINES AND MOTORS USED IN THE AUTOMOTIVE INDUSTRY, BUS TRANSPORTATION INDUSTRY, TRANSPORTATION INDUSTRY, AERONAUTIC INDUSTRY, FOOD AND BEVERAGE INDUSTRY; FUEL FILTERS; OIL FILTERS; AIR FILTERS FOR CLEANING COOLING AIR IN ENGINES OR MOTORS; AIR FILTERS FOR MOTORS OR ENGINES; FILTERS FOR MOTORS OR ENGINES; CARTRIDGES FOR FILTERING MACHINES (U.S. CLS. 13, 19, 21, 23, 31, 34 AND 35).

ELLEN PERKINS, EXAMINING ATTORNEY

SN 85-133,211. LEFTSNRIGHTS, INC., SALT LAKE CITY, UT. FILED 9-20-2010.

TINA L. SNAPP, EXAMINING ATTORNEY

MAKING SOMETHING FROM NOTHING

THE MARK CONSISTS OF STANDARD CHARACTERS WITHOUT CLAIM TO ANY PARTICULAR FONT, STYLE, SIZE, OR COLOR.

CLASS 35—ADVERTISING AND BUSINESS

FOR DISSEMINATION OF ADVERTISING FOR OTHERS VIA THE INTERNET; ON-LINE ADVERTISING AND MARKETING SERVICES; PROVIDING ADVERTISING SERVICES TO DISPLAY ADVERTISEMENTS AND PROMOTIONS ON THE INTERNET FOR OTHERS, NAMELY, IN WEBSITES; PROVIDING A DATABASE FEATURING ADVERTISEMENTS (U.S. CLS. 100, 101 AND 102).

CLASS 42—SCIENTIFIC AND COMPUTER SERVICES

FOR APPLICATION SERVICE PROVIDER, NAMELY, MANAGING, DEVELOPING AND MAINTAINING APPLICATIONS AND SOFTWARE, OF OTHERS IN THE FIELDS OF ADVERTISING AND MARKETING; PROVIDING ONLINE NONDOWNLOADABLE SOFTWARE AND APPLICATIONS FOR USE IN ADVERTISING AND MARKETING (U.S. CLS. 100 AND 101).

DAVID I, EXAMINING ATTORNEY

SN 85-133,331. PARACO GAS CORPORATION, RYE BROOK, NY. FILED 9-20-2010.



OWNER OF U.S. REG. NOS. 3,434,941 AND 3,466,381.

NO CLAIM IS MADE TO THE EXCLUSIVE RIGHT TO USE "PROPANE EXCHANGE", APART FROM THE MARK AS SHOWN.

THE MARK CONSISTS OF THE STYLIZED WORDS/LETTERS "PARACO" FOLLOWED BY "PROPANE X CHANGE". ABOVE THE TERM "PARACO" IS THE STYLIZED DESIGN OF A TORCH.

CLASS 35—ADVERTISING AND BUSINESS

FOR RETAIL AND WHOLESALE STORE SERVICES FEATURING PROPANE GAS TANKS (U.S. CLS. 100, 101 AND 102).

FIRST USE 0-0-2001; IN COMMERCE 0-0-2001.

CLASS 39—TRANSPORTATION AND STORAGE

FOR DISTRIBUTION SERVICES, NAMELY, THE DELIVERY OF BARBECUE PROPANE TANKS (U.S. CLS. 100 AND 105).

FIRST USE 0-0-2001; IN COMMERCE 0-0-2001.

SN 85-133,466. FISHER & PAYKEL HEALTHCARE LIMITED, AUCKLAND 2013, NEW ZEALAND, FILED 9-20-2010.

LABSMART

THE MARK CONSISTS OF STANDARD CHARACTERS WITHOUT CLAIM TO ANY PARTICULAR FONT, STYLE, SIZE, OR COLOR.

PRIORITY CLAIMED UNDER SEC. 44(D) ON NEW ZEALAND APPLICATION NO. 827716, FILED 7-22-2010, REG. NO. 827716, DATED 7-22-2010, EXPIRES 7-22-2020.

CLASS 9—ELECTRICAL AND SCIENTIFIC APPARATUS

FOR COMPUTER HARDWARE AND COMPUTER PERIPHERALS; COMPUTER SOFTWARE FOR USE IN POSITIVE PRESSURE THERAPY AND SLEEP THERAPY; COMPUTER SOFTWARE AND COMPUTER PROGRAMS, FOR USE WITH MEDICAL EQUIPMENT, FOR RECEIVING, ANALYZING, PROCESSING, TRANSMITTING AND DISPLAYING MEDICAL DATA; CONNECTION CABLES AND CABLE CONNECTORS FOR ALL THE AFORESAID GOODS; ELECTRONIC PUBLICATIONS, NAMELY, OPERATION TRAINING MANUALS IN THE FORM OF A COMPUTER PROGRAM FOR THE AFOREMENTIONED GOODS; PARTS AND FITTINGS FOR THE AFOREMENTIONED GOODS; INSTRUCTION MANUALS SOLD AS A UNIT WITH THE AFOREMENTIONED GOODS (U.S. CLS. 21, 23, 26, 36 AND 38).

CLASS 10—MEDICAL APPARATUS

FOR MEDICAL HUMIDIFICATION APPARATUS; MEDICAL APPARATUS FOR THE DIAGNOSIS AND TREATMENT OF OBSTRUCTIVE SLEEP APNEA; MEDICAL APPARATUS, NAMELY, INVASIVE AND NON-INVASIVE VENTILATION APPARATUS AND INSTRUMENTS; MEDICAL APPARATUS AND INSTRUMENTS FOR POSITIVE AIRWAY PRESSURE THERAPY; MEDICAL HUMIDIFIERS AND METERS FOR POSITIVE PRESSURE THERAPY; BREATHING MASKS FOR USE IN TREATING OBSTRUCTIVE SLEEP APNEA; FACIAL MASKS, ORAL MASKS, NASAL MASKS, NASAL CANNULA, MOUTHPIECES, HEADGEAR, ALL BEING FOR MEDICAL PURPOSES; PARTS AND FITTINGS FOR ALL THE AFOREMENTIONED GOODS (U.S. CLS. 26, 39 AND 44).

DAWN HAN, EXAMINING ATTORNEY

SN 85-133,503. SPORT SYNERGY, LLC, MENDHAM, NJ. FILED 9-20-2010.



THE MARK CONSISTS OF AN ARTISTIC RENDERING OF A SMALL HAND PRINT WITHIN THE PALM OF A LARGER HAND PRINT. THE TERM "SPORTSYNERGY" APPEARS BELOW THE HAND PRINTS.

CLASS 9—ELECTRICAL AND SCIENTIFIC APPARATUS

FOR COMPUTER SOFTWARE FOR ANALYZING AND EVALUATING THE SPORTS ABILITIES AND DEVELOPMENT OF CHILDREN AND YOUNG ADULTS; PRERECORDED DVDS AND CDS IN THE FIELD OF EVALUATION AND DEVELOPMENT OF SPORTS ABILITIES OF CHILDREN AND YOUNG ADULTS (U.S. CLS. 21, 23, 26, 36 AND 38).

CLASS 16—PAPER GOODS AND PRINTED MATTER

FOR PRINTED MATERIALS, NAMELY, BOOKS, MAGAZINES, NEWSLETTERS, AND SURVEYS IN THE FIELD OF EVALUATION AND DEVELOPMENT OF SPORTS ABILITIES OF CHILDREN AND YOUNG ADULTS (U.S. CLS. 2, 5, 22, 23, 29, 37, 38 AND 50).

CLASS 25—CLOTHING

FOR SHIRTS, HATS (U.S. CLS. 22 AND 39).

CLASS 35—ADVERTISING AND BUSINESS

FOR PROMOTING PUBLIC AWARENESS OF THE NEED FOR INVOLVEMENT OF CHILDREN AND YOUNG ADULTS IN SPORTS AND FOR POSITIVE DEVELOPMENT OF CHILDREN AND YOUNG ADULTS THROUGH SPORTS IN ORDER TO ESTABLISH AND FOSTER COOPERATIVE COMMUNITY INTERACTION AMONG ATHLETES, COACHES, PARENTS, OFFICIALS AND SPORTS ORGANIZATIONS (U.S. CLS. 100, 101 AND 102).

CLASS 41—EDUCATION AND ENTERTAINMENT

FOR SPORTS CONSULTATION SERVICES, NAMELY, EVALUATING THE DEVELOPMENT OF SPORTS ABILITIES OF CHILDREN AND YOUNG ADULTS AND PROVIDING SPORTS TRAINING ADVICE TO THOSE CHILDREN AND YOUNG ADULTS, PARENTS, COACHES AND OTHER INTERESTED PERSONS REGARDING THE SPORTS ABILITIES AND DEVELOPMENT OF SPORTS ABILITIES OF THE CHILDREN AND THE YOUNG ADULTS; CONDUCTING AND ANALYZING SURVEYS RELATING TO SPORTS ABILITIES AND DEVELOPMENT OF SPORTS ABILITIES OF CHILDREN AND YOUNG ADULTS (U.S. CLS. 100, 101 AND 107).

JULIE VEPPUMTHARA, EXAMINING ATTORNEY

SN 85-133,555. TOMTEC IMAGING SYSTEMS GMBH, UNTERSCHLEISSHEIM, FED REP GERMANY, FILED 9-20-2010.

Re-Com

THE MARK CONSISTS OF STANDARD CHARACTERS WITHOUT CLAIM TO ANY PARTICULAR FONT, STYLE, SIZE, OR COLOR.

PRIORITY CLAIMED UNDER SEC. 44(D) ON FED REP GERMANY APPLICATION NO. 302010054349, FILED 9-18-2010, REG. NO. 302010054349, DATED 2-22-2011, EXPIRES 9-30-2020.

CLASS 9—ELECTRICAL AND SCIENTIFIC APPARATUS

FOR COMPUTER HARDWARE AND COMPUTER SOFTWARE FOR THE COLLECTION, EDITING, ORGANIZING, MODIFYING, BOOK MARKING, PROCESSING, STORAGE AND SHARING OF DATA AND INFORMATION FOR USE IN RELATION TO DIGITAL ANIMATION AND SPECIAL EFFECTS OF MEDICAL IMAGES; COMPUTER SOFTWARE FOR ORGANIZING AND VIEWING DIGITAL IMAGES AND PHOTOGRAPHS; COMPUTER SOFTWARE FOR ULTRASOUND IMAGING DATA PROCESSING; COMPUTER DATABASE MANAGEMENT SOFTWARE FOR USE IN ORGANIZING MEDICAL DATA; COMPUTER GRAPHICS SOFTWARE; COMPUTER HARDWARE AND COMPUTER SOFTWARE PROGRAMS FOR THE INTEGRATION OF MEDICAL TEXT, AUDIO, GRAPHICS, STILL IMAGES AND MOVING PICTURES INTO AN INTERACTIVE DELIVERY FOR MULTIMEDIA APPLICATIONS (U.S. CLS. 21, 23, 26, 36 AND 38).

CLASS 10—MEDICAL APPARATUS

FOR MEDICAL DIAGNOSTIC APPARATUS, NAMELY, TWO, THREE, AND FOUR DIMENSIONAL ULTRASOUND SYSTEMS COMPRISED OF ULTRASOUND DIAGNOSTIC APPARATUS, COMPUTER HARDWARE, AND COMPUTER SOFTWARE FOR MAKING TWO, THREE, AND FOUR DIMENSIONAL RECONSTRUCTIONS; APPARATUS FOR CLINICAL DIAGNOSIS; MEDICAL INSTRUMENT FOR CARDIOVASCULAR DIAGNOSTICS (U.S. CLS. 26, 39 AND 44).

CLASS 42—SCIENTIFIC AND COMPUTER SERVICES

FOR COMPUTER PROGRAMMING FOR OTHERS IN THE MEDICAL FIELD; RENTAL OF APPLICATION SOFTWARE; RENTAL OF COMPUTERS; TECHNICAL CONSULTANCY REGARDING THE FIELD OF ULTRASOUND TECHNOLOGY; CONSULTING SERVICES IN THE FIELD OF COMPUTER-BASED INFORMATION SYSTEMS FOR MEDICAL BUSINESSES; DATA MINING; MEDICAL DATABASE DESIGN AND DEVELOPMENT; COMPILING DATA FOR RESEARCH PURPOSES IN THE FIELD OF MEDICAL SCIENCE AND MEDICAL CONSULTANCY (U.S. CLS. 100 AND 101).

JAY FLOWERS, EXAMINING ATTORNEY

SN 85-133,798. SHMIRSHKY UNIVERSAL, LLC, FORMERLY SHMIRSKHY BUSINESS, LLC, CORONADO, CA. FILED 9-20-2010.

THE PURSUIT OF HORMONE HAPPINESS

THE MARK CONSISTS OF STANDARD CHARACTERS WITHOUT CLAIM TO ANY PARTICULAR FONT, STYLE, SIZE, OR COLOR.

CLASS 5—PHARMACEUTICALS

FOR VITAMIN AND MINERAL SUPPLEMENTS; DIETARY AND NUTRITIONAL SUPPLEMENTS; PERSONAL LUBRICANTS (U.S. CLS. 6, 18, 44, 46, 51 AND 52).

CLASS 16—PAPER GOODS AND PRINTED MATTER

FOR PRINTED MATTER, NAMELY, BOOKS IN THE FIELD OF WOMEN'S HEALTH ISSUES, AND STATIONERY (U.S. CLS. 2, 5, 22, 23, 29, 37, 38 AND 50).

CLASS 25—CLOTHING

FOR CLOTHING, NAMELY, T-SHIRTS, SWEAT SHIRTS, BANDANAS; MEN'S AND WOMEN'S EXERCISE CLOTHES, NAMELY, SWEAT PANTS, SWEAT SHIRTS, SWEAT SUITS, BODY SUITS, FITNESS TOPS, HEADBANDS, KNITTED CAPS, NECK GAITERS, PANTS, SHIRTS, SHORTS, SOCKS, TENNIS DRESSES, TENNIS SKIRTS, TIGHTS, UNITARDS, VESTS AND WARM UP SUITS, WRISTBANDS, JACKETS, SWEATERS, LONG UNDERWEAR, MEN'S AND WOMEN'S UNDERWEAR, BRAS, SPORTS BRAS, BOXER SHORTS, BOXER BRIEFS; FOOTWEAR; HEADWEAR, NAMELY, HATS, VISORS, AND HEADBANDS (U.S. CLS. 22 AND 39).

CLASS 41—EDUCATION AND ENTERTAINMENT

FOR ENTERTAINMENT SERVICES, NAMELY, PROVIDING WORKSHOPS AND SEMINARS IN THE FIELD OF WOMEN'S ISSUES, PROVIDING PODCASTS IN THE FIELD OF WOMEN'S ISSUES, PROVIDING WEBCASTS IN THE FIELD OF WOMEN'S ISSUES, LECTURES AND SPEECHES IN THE FIELD OF WOMEN'S ISSUES, CONTINUING TALK SHOWS BROADCAST OVER TELEVISION, THE INTERNET AND SATELLITE RADIO, AND FILM PRODUCTION IN THE FIELD OF WOMEN'S ISSUES, ALL THE FOREGOING RELATING TO THE PERSONAL EXPERIENCES OR WRITINGS OF ELLEN SARVER DOLGEN (U.S. CLS. 100, 101 AND 107).

JASON TURNER, EXAMINING ATTORNEY

SN 85-134,111. COLE HAAN, YARMOUTH, ME. FILED 9-20-2010.

COLE HAAN WORKBENCH

THE MARK CONSISTS OF STANDARD CHARACTERS WITHOUT CLAIM TO ANY PARTICULAR FONT, STYLE, SIZE, OR COLOR.

OWNER OF U.S. REG. NOS. 1,607,846, 3,618,399 AND OTHERS.

THE NAME "COLE HAAN" DOES NOT IDENTIFY A LIVING INDIVIDUAL.

CLASS 18—LEATHER GOODS

FOR HAND BAGS, PURSES, SHOULDER BAGS, TOTE BAGS, WALLETS, LEATHER KEY CHAINS, IMITATION LEATHER KEY CHAINS, KEY CASES, WINE BAGS WITH HANDLES FOR CARRYING AND HANDLING WINE, COSMETIC CASES SOLD EMPTY, TOILETRY CASES SOLD EMPTY, SHAVING CASES SOLD EMPTY, LUGGAGE, NAME CARD CASES, CREDIT CARD CASES, BRIEFCASES, BRIEFCASE-TYPE PORTFOLIOS, MESSENGER BAGS, DUFFLE BAGS, WAIST PACKS (U.S. CLS. 1, 2, 3, 22 AND 41).

CLASS 25—CLOTHING

FOR FOOTWEAR, HOSIERY, COATS, BLAZERS, ANORAKS, SWEATERS, VESTS, SWEATSHIRTS, GLOVES, TIES, SOCKS, BELTS, JACKETS, SCARVES, WRAPS, PONCHOS, HEADWEAR, SHIRTS, T-SHIRTS, PANTS, SHORTS, DRESSES AND SKIRTS (U.S. CLS. 22 AND 39).

CLASS 35—ADVERTISING AND BUSINESS

FOR RETAIL STORE SERVICES AND ON-LINE RETAIL STORE SERVICES FEATURING APPAREL, APPAREL ACCESSORIES, BELTS, FOOTWEAR, FOOTWEAR ACCESSORIES, HEADWEAR, EYEWEAR AND EYEWEAR ACCESSORIES, HANDBAGS, BAGS OF ALL KINDS, BRIEFCASES, LUGGAGE, UMBRELLAS, ACCESSORIES MADE OF LEATHER AND IMITATION LEATHER, NAMELY, SMALL LEATHER AND IMITATION LEATHER CASES, WALLETS, KEY CHAINS, PROTECTIVE SLEEVES AND CASES FOR PORTABLE ELECTRONIC DEVICES, COMPUTERS, AND CELL PHONES (U.S. CLS. 100, 101 AND 102).

CLASS 40—MATERIAL TREATMENT

FOR CUSTOM IMPRINTING, ETCHING, AND EMBOSSED WORDS, DESIGNS, IMAGES, PATTERNS OR COLORS ON FOOTWEAR, APPAREL, BELTS, HEADWEAR, HAND BAGS, BAGS OF ALL KINDS, BRIEFCASES, LUGGAGE, SMALL LEATHER AND IMITATION LEATHER CASES, KEY CHAINS, WALLETS, AND PROTECTIVE CASES AND SLEEVES FOR PORTABLE ELECTRONIC DEVICES, COMPUTERS, AND CELL PHONES (U.S. CLS. 100, 103 AND 106).

CLASS 42—SCIENTIFIC AND COMPUTER SERVICES

FOR CUSTOM DESIGN OF FOOTWEAR, APPAREL, BELTS, HEADWEAR, HAND BAGS, BAGS OF ALL KINDS, BRIEFCASES, LUGGAGE, SMALL LEATHER AND IMITATION LEATHER CASES, KEY CHAINS, WALLETS, AND PROTECTIVE CASES AND SLEEVES FOR PORTABLE ELECTRONIC DEVICES, COMPUTERS, AND CELL PHONES BASED ON PERSONAL SELECTIONS BY THE CUSTOMER (U.S. CLS. 100 AND 101).

MARLENE BELL, EXAMINING ATTORNEY

SN 85-134,217. HUMAN MED AG, SCHWERN, FED REP GERMANY, FILED 9-21-2010.

J-AFT

THE MARK CONSISTS OF STANDARD CHARACTERS WITHOUT CLAIM TO ANY PARTICULAR FONT, STYLE, SIZE, OR COLOR.

PRIORITY CLAIMED UNDER SEC. 44(D) ON ERPNTY TM OFC APPLICATION NO. 009379272, FILED 9-16-2010, REG. NO. 009379272, DATED 2-10-2011, EXPIRES 9-16-2020.

CLASS 10—MEDICAL APPARATUS

FOR INSTRUMENTS AND APPARATUS FOR USE IN MEDICAL WATER JET CUTTING, EXCEPT FOR VETERINARY PURPOSES (U.S. CLS. 26, 39 AND 44).

CLASS 35—ADVERTISING AND BUSINESS

FOR ADVERTISING AND ADVERTISEMENT SERVICES, NAMELY, DEVELOPMENT OF ADVERTISING CAMPAIGNS AND DISSEMINATION OF ADVERTISEMENTS, FOR OTHERS IN THE FIELDS OF MEDICAL SERVICES FOR HUMANS, NAMELY, SURGERY (U.S. CLS. 100, 101 AND 102).

CLASS 44—MEDICAL, BEAUTY AND AGRICULTURAL SERVICES

FOR MEDICAL SERVICES FOR HUMANS, NAMELY, SURGERY; HEALTH AND BEAUTY CARE FOR HUMANS (U.S. CLS. 100 AND 101).
KATHY DE JONGE, EXAMINING ATTORNEY

CLASS 9—ELECTRICAL AND SCIENTIFIC APPARATUS

FOR RELAY EQUIPMENT FOR DEAF, HARD OF HEARING, AND HEARING IMPAIRED PERSONS, NAMELY, VIDEOPHONES, TEXT TELEPHONES, PDAS, WIRELESS ELECTRONIC COMMUNICATION DEVICES, COMPUTER HARDWARE (U.S. CLS. 21, 23, 26, 36 AND 38).

SN 85-134,572. NATIONAL AIR FILTRATION ASSOCIATION, VIRGINIA BEACH, VA. FILED 9-21-2010.



OWNER OF U.S. REG. NOS. 1,379,798, 3,701,093 AND 3,930,802.

THE MARK CONSISTS OF THREE AIR FILTERS WITH AIR FLOWING THROUGH THEM THEN THE WORDS "NAFA NATIONAL AIR FILTRATION ASSOCIATION". SEC. 2(F) AS TO "NATIONAL AIR FILTRATION ASSOCIATION".

CLASS 38—COMMUNICATION

FOR PROVIDING TRANSMISSION OF INFORMATION AND ELECTRONIC MESSAGES TO PERSONS WHO ARE DEAF, HARD OF HEARING, AND HEARING IMPAIRED VIA A GLOBAL COMPUTER NETWORK, TELEPHONE, AND WIRELESS DEVICES; TELECOMMUNICATIONS RELAY SERVICES FOR DEAF, HARD OF HEARING, AND HEARING IMPAIRED PERSONS; CAPTIONED TELEPHONE SERVICES FOR PERSONS WHO ARE DEAF, HARD OF HEARING, OR HEARING IMPAIRED (U.S. CLS. 100, 101 AND 104).
HELENE LIWINSKI, EXAMINING ATTORNEY

SN 85-134,771. NEW MAJORITY CALIFORNIA, COSTA MESA, CA. FILED 9-21-2010.

CLASS 35—ADVERTISING AND BUSINESS

FOR BUSINESS SERVICES, NAMELY, FORMULATION OF BEST PRACTICES IN THE FIELD OF AIR FILTRATION (U.S. CLS. 100, 101 AND 102).

NEW MAJORITY SANTA BARBARA

CLASS 41—EDUCATION AND ENTERTAINMENT

FOR EDUCATIONAL SERVICES, NAMELY, CONDUCTING CLASSES, SEMINARS, FORUMS AND WORKSHOPS ON TECHNICAL STANDARDS, PERFORMANCE STANDARDS, GOVERNMENT REGULATIONS, AND PRODUCTS IN THE FIELD OF AIR FILTRATION (U.S. CLS. 100, 101 AND 107).

THE MARK CONSISTS OF STANDARD CHARACTERS WITHOUT CLAIM TO ANY PARTICULAR FONT, STYLE, SIZE, OR COLOR.
OWNER OF U.S. REG. NOS. 3,479,711, 3,511,505 AND OTHERS.

NO CLAIM IS MADE TO THE EXCLUSIVE RIGHT TO USE "SANTA BARBARA", APART FROM THE MARK AS SHOWN.

CLASS 42—SCIENTIFIC AND COMPUTER SERVICES

FOR TESTING, ANALYSIS AND EVALUATION OF AIR FILTRATION PRODUCTS OF OTHERS FOR THE PURPOSE OF CERTIFICATION; ACCREDITATION SERVICES, NAMELY, DEVELOPING AND ADMINISTERING STANDARDS AND PROCEDURES FOR CERTIFYING PROFESSIONALS IN THE FIELD OF AIR FILTRATION; TESTING ANALYSIS AND EVALUATION OF THE LABORATORIES OF OTHERS IN THE FIELD OF AIR FILTRATION FOR THE PURPOSE OF CERTIFICATION (U.S. CLS. 100 AND 101).
RON FAIRBANKS, EXAMINING ATTORNEY

CLASS 35—ADVERTISING AND BUSINESS

FOR ASSOCIATION SERVICES, NAMELY, PROMOTING FISCALLY RESPONSIBLE GOVERNMENT POLICIES; ASSOCIATION SERVICES, NAMELY, PROMOTING THE INTERESTS OF INDIVIDUALS AND GROUPS WHO SUPPORT FISCALLY RESPONSIBLE GOVERNMENT POLICIES, SPECIFICALLY THROUGH SPONSORED POLITICAL ACTION COMMITTEES (U.S. CLS. 100, 101 AND 102).

SN 85-134,732. PURPLE COMMUNICATIONS, INC., ROCKLIN, CA. FILED 9-21-2010.

CLEARCAPTIONS

THE MARK CONSISTS OF STANDARD CHARACTERS WITHOUT CLAIM TO ANY PARTICULAR FONT, STYLE, SIZE, OR COLOR.

CLASS 41—EDUCATION AND ENTERTAINMENT

FOR EDUCATION SERVICES AND OUTREACH, NAMELY, PROVIDING FORUMS, SEMINARS AND SPEAKER WORKSHOPS REGARDING EXISTING AND PROPOSED GOVERNMENT POLICIES; EDUCATIONAL SERVICES, NAMELY, PROVIDING TRAINING TO CANDIDATES IN THE FIELDS OF POLITICAL AND GOVERNMENT POLICIES AND FUNCTIONS, PUBLIC COMMUNICATIONS AND FUNDRAISING; EDUCATION SERVICES AND OUTREACH, NAMELY, FORUMS AND SEMINARS TO PROMOTE FISCALLY RESPONSIBLE CANDIDATES AND IDEAS (U.S. CLS. 100, 101 AND 107).
SUZANNE BLANE, EXAMINING ATTORNEY

SN 85-134,983. REED OMARY, WILMETTE, IL. AND ANDREW LARSON, WILMETTE, IL. FILED 9-21-2010.

MagnetoSphere

THE MARK CONSISTS OF STANDARD CHARACTERS WITHOUT CLAIM TO ANY PARTICULAR FONT, STYLE, SIZE, OR COLOR.

CLASS 5—PHARMACEUTICALS

FOR DRUG DELIVERY AGENTS IN THE FORM OF A COATING FOR THERAPEUTIC AGENTS THAT FACILITATE THE DELIVERY OF A WIDE RANGE OF PHARMACEUTICALS; DRUG DELIVERY AGENTS IN THE FORM OF CAPSULES THAT PROVIDE CONTROLLED RELEASE OF THE ACTIVE INGREDIENTS FOR A WIDE VARIETY OF PHARMACEUTICALS; DRUG DELIVERY AGENTS IN THE FORM OF TABLETS THAT PROVIDE CONTROLLED RELEASE OF THE ACTIVE INGREDIENTS FOR A WIDE VARIETY OF PHARMACEUTICALS; PHARMACEUTICAL PREPARATIONS FOR THE PREVENTION OF CANCER; PHARMACEUTICAL PREPARATIONS FOR THE TREATMENT AND PREVENTION OF CANCER; PHARMACEUTICAL PREPARATIONS FOR CANCER; PHARMACEUTICAL PRODUCTS FOR THE PREVENTION AND TREATMENT OF CANCER; RADIOACTIVE PHARMACEUTICAL PREPARATIONS FOR USE IN VIVO DIAGNOSTIC OR THERAPEUTIC USE; THERAPEUTIC PHARMACEUTICAL FOR THE TREATMENT OF CANCER; TUMOR SUPPRESSING AGENTS (U.S. CLS. 6, 18, 44, 46, 51 AND 52).

CLASS 10—MEDICAL APPARATUS

FOR DRUG DELIVERY SYSTEMS; ELECTROMAGNETIC DRUG DELIVERY APPARATUS FOR MEDICAL USE; IMPLANTABLE RADIATION THERAPY DEVICES CONSISTING OF RADIOACTIVE SEEDS AND A BIOABSORBABLE CARRIER ASSEMBLY; MAGNETS FOR MEDICAL PURPOSES; MEDICAL APPARATUS AND UNITS FOR DOSAGE, MEASURING AND MONITORING, NAMELY, DRUG DELIVERY DEVICES AND SYSTEMS; MEDICAL APPARATUS FOR INTRODUCING PHARMACEUTICAL PREPARATIONS INTO THE HUMAN BODY; MEDICAL APPARATUS, NAMELY, INFUSION AND INJECTION DEVICES FOR ADMINISTERING DRUGS (U.S. CLS. 26, 39 AND 44).
NAPOLEON SHARMA, EXAMINING ATTORNEY

SN 85-135,005. REED OMARY, WILMETTE, IL. AND ANDREW LARSON, WILMETTE, IL. FILED 9-21-2010.

ElectroSphere

THE MARK CONSISTS OF STANDARD CHARACTERS WITHOUT CLAIM TO ANY PARTICULAR FONT, STYLE, SIZE, OR COLOR.

CLASS 5—PHARMACEUTICALS

FOR DRUG DELIVERY AGENTS IN THE FORM OF A COATING FOR THERAPEUTIC AGENTS THAT FACILITATE THE DELIVERY OF A WIDE RANGE OF PHARMACEUTICALS; DRUG DELIVERY AGENTS IN THE FORM OF CAPSULES THAT PROVIDE CONTROLLED RELEASE OF THE ACTIVE INGREDIENTS FOR A WIDE VARIETY OF PHARMACEUTICALS; DRUG DELIVERY AGENTS IN THE FORM OF TABLETS THAT PROVIDE CONTROLLED RELEASE OF THE ACTIVE INGREDIENTS FOR A WIDE VARIETY OF PHARMACEUTICALS; PHARMACEUTICAL PREPARATIONS FOR THE PREVENTION OF CANCER; PHARMACEUTICAL PREPARATIONS FOR THE TREATMENT AND PREVENTION OF CANCER; PHARMACEUTICAL PREPARATIONS FOR THE TREATMENT OF CANCER; PHARMACEUTICAL PREPARATIONS FOR USE IN CHEMOTHERAPY; PHARMACEUTICAL PREPARATIONS FOR CANCER; PHARMACEUTICAL PRODUCTS FOR THE PREVENTION AND TREATMENT OF CANCER; THERAPEUTIC PHARMACEUTICAL FOR THE TREATMENT OF CANCER; TUMOR SUPPRESSING AGENTS (U.S. CLS. 6, 18, 44, 46, 51 AND 52).

CLASS 10—MEDICAL APPARATUS

FOR DRUG DELIVERY SYSTEMS; ELECTROMAGNETIC DRUG DELIVERY APPARATUS FOR MEDICAL USE; LOW FREQUENCY ELECTRIC THERAPY APPARATUS; LOW FREQUENCY ELECTROMAGNETIC THERAPY APPARATUS; MEDICAL APPARATUS AND UNITS FOR DOSAGE, MEASURING AND MONITORING, NAMELY, DRUG DELIVERY DEVICES AND SYSTEMS; MEDICAL APPARATUS FOR INTRODUCING PHARMACEUTICAL PREPARATIONS INTO THE HUMAN BODY; MEDICAL APPARATUS, NAMELY, ELECTRIC HEATING DEVICES FOR CURATIVE TREATMENT; MEDICAL APPARATUS, NAMELY, INFUSION AND INJECTION DEVICES FOR ADMINISTERING DRUGS (U.S. CLS. 26, 39 AND 44).
NAPOLEON SHARMA, EXAMINING ATTORNEY

SN 85-135,360. CITY OF TEMPE, TEMPE, AZ. FILED 9-22-2010.

ERIC

THE MARK CONSISTS OF STANDARD CHARACTERS WITHOUT CLAIM TO ANY PARTICULAR FONT, STYLE, SIZE, OR COLOR.

CLASS 16—PAPER GOODS AND PRINTED MATTER

FOR PRINTED EDUCATIONAL MATERIALS IN THE FIELD OF RECYCLING AND CONSERVATION; PRINTED MATTER, NAMELY, NEWSPAPERS, PRINTED PERIODICALS, NEWSLETTERS, AND BROCHURES ALL IN THE FIELDS OF RECYCLING AND CONSERVATION (U.S. CLS. 2, 5, 22, 23, 29, 37, 38 AND 50).
FIRST USE 7-1-2009; IN COMMERCE 7-1-2009.

CLASS 41—EDUCATION AND ENTERTAINMENT

FOR EDUCATIONAL SERVICES, NAMELY, A LEARNING CENTER FEATURING PRACTICAL TRAINING, EXHIBITS, CLASSES, AND INTERACTIVE PLAY AREAS IN THE FIELD OF RECYCLING AND CONSERVATION; EDUCATIONAL SERVICES, NAMELY, PROVIDING SEMINARS AND WORKSHOPS IN THE FIELD OF RECYCLING AND CONSERVATION (U.S. CLS. 100, 101 AND 107).

FIRST USE 7-1-2009; IN COMMERCE 7-1-2009.
SAIMA MAKHDOOM, EXAMINING ATTORNEY

SN 85-135,687. CERNER INNOVATION, INC., OVERLAND PARK, KS. FILED 9-22-2010.

HEALTH+CARE

SN 85-135,644. OUTERCURVE FOUNDATION, WAKEFIELD, MA. FILED 9-22-2010.

OUTERCURVE

THE MARK CONSISTS OF STANDARD CHARACTERS WITHOUT CLAIM TO ANY PARTICULAR FONT, STYLE, SIZE, OR COLOR.

CLASS 9—ELECTRICAL AND SCIENTIFIC APPARATUS

FOR DOWNLOADABLE ELECTRONIC PUBLICATIONS IN THE NATURE OF INSTRUCTIONAL MATERIALS, PAMPHLETS, WHITE PAPERS, PRESENTATIONS, JOURNALS, AND MANUALS IN THE FIELDS OF COMPUTER SOFTWARE INDUSTRY TECHNICAL STANDARDS, SPECIFICATIONS, INFORMATION TECHNOLOGY, AND SOFTWARE AND PLATFORM DEVELOPMENT; DOWNLOADABLE ELECTRONIC PUBLICATIONS IN THE NATURE OF INSTRUCTIONAL MATERIALS, PAMPHLETS, WHITE PAPERS, PRESENTATIONS, AND MANUALS IN THE FIELD OF VOLUNTARY COMPUTER SOFTWARE STANDARDS (U.S. CLS. 21, 23, 26, 36 AND 38).

CLASS 35—ADVERTISING AND BUSINESS

FOR ASSOCIATION SERVICES, NAMELY, PROMOTING THE INTERESTS OF THE COMPUTER SOFTWARE DEVELOPMENT INDUSTRY AND PROMOTING BOTH THE COMPUTER SOFTWARE INDUSTRY'S AWARENESS AND PUBLIC AWARENESS OF THE NEED FOR COMPUTER SOFTWARE STANDARDS DEVELOPMENT ACTIVITY, INCLUDING COOPERATIVE RESEARCH ACTIVITIES AND JOINT DEVELOPMENT OF STANDARDS FOR COMPUTER SOFTWARE DEVELOPERS (U.S. CLS. 100, 101 AND 102).

CLASS 42—SCIENTIFIC AND COMPUTER SERVICES

FOR DEVELOPMENT OF VOLUNTARY STANDARDS FOR COMPLIANCE WITH OPEN SOURCE SOFTWARE (U.S. CLS. 100 AND 101).
GINA FINK, EXAMINING ATTORNEY

THE MARK CONSISTS OF STANDARD CHARACTERS WITHOUT CLAIM TO ANY PARTICULAR FONT, STYLE, SIZE, OR COLOR.

CLASS 9—ELECTRICAL AND SCIENTIFIC APPARATUS

FOR COMPUTER SOFTWARE FOR MANAGING, STORING, ANALYZING, MAINTAINING, PROCESSING, STRUCTURING, REVIEWING, BUILDING, EDITING, DISTRIBUTING, COMMUNICATING, ORGANIZING, SHARING, REFERENCING, MONITORING AND INTEGRATING HEALTHCARE INFORMATION IN SUPPORT OF A PATIENT-CENTERED MEDICAL HOME, VIRTUAL MEDICAL HOME, ACCOUNTABLE CARE ORGANIZATION, ACCOUNTABLE HEALTH ORGANIZATION AND COMMUNITY HEALTH ORGANIZATION; COMPUTER SOFTWARE FOR AUTOMATING CLINICAL, FINANCIAL AND ADMINISTRATIVE HEALTHCARE PROCESSES IN SUPPORT OF A PATIENT-CENTERED MEDICAL HOME, VIRTUAL MEDICAL HOME, ACCOUNTABLE CARE ORGANIZATION, ACCOUNTABLE HEALTH ORGANIZATION AND COMMUNITY HEALTH ORGANIZATION (U.S. CLS. 21, 23, 26, 36 AND 38).

CLASS 35—ADVERTISING AND BUSINESS

FOR BUSINESS DEVELOPMENT, MANAGEMENT AND ADMINISTRATION SERVICES, NAMELY, THE PROVISION OF ASSISTANCE TO PHYSICIANS, MEDICAL GROUPS AND OTHER HEALTHCARE PROVIDERS IN THE DEVELOPMENT, MANAGEMENT AND ADMINISTRATION OF A PATIENT-CENTERED MEDICAL HOME, VIRTUAL MEDICAL HOME, ACCOUNTABLE CARE ORGANIZATION, ACCOUNTABLE HEALTH ORGANIZATION AND COMMUNITY HEALTH ORGANIZATION; BUSINESS DATA ANALYSIS SERVICES, NAMELY, COLLECTION, AGGREGATION, ANALYSIS AND REPORTING OF COMPREHENSIVE, PATIENT-CENTERED HEALTH AND HEALTHCARE DATA FOR USE IN ASSESSING PRACTICE MANAGEMENT, CLINICAL PERFORMANCE, PRODUCT PERFORMANCE, HEALTH OUTCOMES, ECONOMICS AND QUALITY OF CARE (U.S. CLS. 100, 101 AND 102).

CLASS 42—SCIENTIFIC AND COMPUTER SERVICES

FOR COMPUTER SERVICES, NAMELY, DEVELOPING AND PROVIDING TEMPORARY USE OF NON-DOWNLOADABLE ELECTRONIC HEALTH RECORD AND PRACTICE MANAGEMENT SOFTWARE SOLUTIONS AND CLINICAL INFORMATICS INFORMATION SOFTWARE FOR USE BY HEALTHCARE PROVIDERS, PAYORS, HEALTH PLAN SPONSORS AND CONSUMERS IN SUPPORT OF A PATIENT-CENTERED MEDICAL HOME, VIRTUAL MEDICAL HOME, ACCOUNTABLE CARE ORGANIZATION, ACCOUNTABLE HEALTH ORGANIZATION AND COMMUNITY HEALTH ORGANIZATION (U.S. CLS. 100 AND 101).

CLASS 44—MEDICAL, BEAUTY AND AGRICULTURAL SERVICES

FOR PROVIDING HEALTH INFORMATION BETWEEN AND AMONG CONSUMERS AND PHYSICIANS, HOSPITALS, HEALTH MAINTENANCE ORGANIZATIONS, PHARMACIES AND OTHER HEALTHCARE PROVIDERS THROUGH HEALTH RISK APPRAISALS, PERSONAL HEALTH PROFILES, TEST RESULTS, AND HEALTH ASSESSMENTS TO ENABLE CONSUMERS, EMPLOYERS AND HEALTH PLAN SPONSORS TO MONITOR, MANAGE AND MAINTAIN THEIR PERSONAL HEALTH (U.S. CLS. 100 AND 101).
SANI KHOURI, EXAMINING ATTORNEY

SN 85-135,714. NEW YORK STATE DEPARTMENT OF PUBLIC SERVICE, ALBANY, NY. FILED 9-22-2010.

BEAMNY

THE MARK CONSISTS OF STANDARD CHARACTERS WITHOUT CLAIM TO ANY PARTICULAR FONT, STYLE, SIZE, OR COLOR.

CLASS 35—ADVERTISING AND BUSINESS

FOR CONSULTING SERVICES IN THE FIELD OF ENERGY EFFICIENCY AND ENERGY USAGE MANAGEMENT; PROMOTING PUBLIC AWARENESS OF THE NEED FOR HEIGHTENING ENERGY CONSERVATION AWARENESS; PROMOTING PUBLIC AWARENESS REGARDING CLEAN, RENEWABLE ENERGY, ENERGY CONSERVATION, AND LONG-TERM ENERGY EFFICIENCY; PROCESSING ENERGY UTILITY CUSTOMER REBATES FOR UTILITY COMPANIES; DEVELOPING ADVERTISING CAMPAIGNS FOR OTHERS GEARED TOWARD ENVIRONMENTAL ISSUES, NAMELY, REDUCING ENERGY USAGE AND PROMOTING ENERGY EFFICIENCY (U.S. CLS. 100, 101 AND 102).

CLASS 41—EDUCATION AND ENTERTAINMENT

FOR EDUCATION SERVICES, NAMELY, PROVIDING CLASSES, SEMINARS AND WORKSHOPS IN THE FIELDS OF ENERGY AWARENESS (U.S. CLS. 100, 101 AND 107).

CLASS 42—SCIENTIFIC AND COMPUTER SERVICES

FOR PROVIDING A WEBSITE FEATURING INFORMATION AND CONTENT IN THE FIELD OF ENVIRONMENTAL AWARENESS AND ENERGY AWARENESS CONSERVATION, NAMELY, CLIMATE CHANGE AND GLOBAL WARMING AND ASSOCIATED RELATED FIELDS INCLUDING GREEN BUILDING, PLANNING, RENEWABLE ENERGY, SUSTAINABLE COMMUNITIES, CONSERVATION, AND OTHER HUMAN ACTIVITIES AFFECTING CARBON USE AND ITS IMPACTS ON THE WORLD (U.S. CLS. 100 AND 101).
ROBERT C. CLARK JR., EXAMINING ATTORNEY

SN 85-135,803. MOUNTAIN STATES EMPLOYERS COUNCIL, INC., DENVER, CO. FILED 9-22-2010.



OWNER OF U.S. REG. NOS. 2,959,612 AND 2,963,262.
NO CLAIM IS MADE TO THE EXCLUSIVE RIGHT TO USE "EMPLOYERS COUNCIL, INC." AND "EMPLOYMENT LAW" AND "HR" AND "TRAINING" AND "SURVEYS", APART FROM THE MARK AS SHOWN.

THE MARK CONSISTS OF STYLIZED LETTER "M" WITH WORDS "MOUNTAIN STATES EMPLOYERS COUNCIL, INC." TO THE RIGHT AND A SWOOSH DESIGN AROUND THE WORDING BELOW THE WORDS AND DESIGN ARE THE WORDS "EMPLOYMENT LAW", "HR", "TRAINING" AND "SURVEYS" ALL SEPARATED BY A DOT.

CLASS 35—ADVERTISING AND BUSINESS

FOR BUSINESS CONSULTING AND ADVISORY SERVICES, HUMAN RESOURCES CONSULTING SERVICES (U.S. CLS. 100, 101 AND 102).
FIRST USE 10-0-2007; IN COMMERCE 10-0-2007.

CLASS 41—EDUCATION AND ENTERTAINMENT

FOR EDUCATIONAL SERVICES, NAMELY, PROVIDING SEMINARS, CLASSES, COURSES, AND WORKSHOPS IN THE FIELDS OF BUSINESS MANAGEMENT, MANAGEMENT OF HUMAN RESOURCES AND EMPLOYMENT LAW (U.S. CLS. 100, 101 AND 107).
FIRST USE 10-0-2007; IN COMMERCE 10-0-2007.

CLASS 45—PERSONAL AND LEGAL SERVICES

FOR LEGAL SERVICES IN THE FIELD OF EMPLOYMENT LAW (U.S. CLS. 100 AND 101).
FIRST USE 10-0-2007; IN COMMERCE 10-0-2007.
CHRISTINA SOBRAL, EXAMINING ATTORNEY

SN 85-136,190. KATHERINE TABERNER, VANCOUVER, BC, CANADA, AND KIRSTEN TABERNER SIGGINS, GLENDALE, CA. FILED 9-23-2010.

COACHING CULTURE

THE MARK CONSISTS OF STANDARD CHARACTERS WITHOUT CLAIM TO ANY PARTICULAR FONT, STYLE, SIZE, OR COLOR.
NO CLAIM IS MADE TO THE EXCLUSIVE RIGHT TO USE "COACHING", APART FROM THE MARK AS SHOWN.

CLASS 9—ELECTRICAL AND SCIENTIFIC APPARATUS

FOR VIDEO MEDIA, NAMELY, CD-ROMS AND PRE-RECORDED FLASH DRIVES CONTAINING EDUCATIONAL AND MOTIVATIONAL MATERIAL IN THE FIELD OF PERSONAL POTENTIAL; ELECTRONIC PUBLICATIONS IN THE NATURE OF TRAINING MANUALS AND BOOKS CONTAINING EDUCATION AND MOTIVATIONAL MATERIAL IN THE FIELD OF PERSONAL POTENTIAL RECORDED ON COMPUTER MEDIA; DOWNLOADABLE ELECTRONIC PUBLICATIONS IN THE NATURE OF TRAINING MANUALS AND BOOKS CONTAINING EDUCATIONAL AND MOTIVATIONAL MATERIAL IN THE FIELD OF PERSONAL POTENTIAL (U.S. CLS. 21, 23, 26, 36 AND 38).

CLASS 16—PAPER GOODS AND PRINTED MATTER

FOR PRINTED MATTER, NAMELY, TRAINING MANUALS AND BOOKS CONTAINING EDUCATIONAL AND MOTIVATIONAL MATERIAL IN THE FIELD OF PERSONAL POTENTIAL (U.S. CLS. 2, 5, 22, 23, 29, 37, 38 AND 50).

CLASS 41—EDUCATION AND ENTERTAINMENT

FOR PROFESSIONAL COACHING SERVICES IN THE FIELD OF PERSONAL IMPROVEMENT; FACILITATION SERVICES, NAMELY, PROVIDING A WEBSITE FEATURING BLOG CONTENT IN THE FIELD OF PERSONAL IMPROVEMENT (U.S. CLS. 100, 101 AND 107).

CLASS 45—PERSONAL AND LEGAL SERVICES

FOR CONSULTING SERVICES IN THE FIELD OF PERSONAL IMPROVEMENT (U.S. CLS. 100 AND 101).
PAM WILLIS, EXAMINING ATTORNEY

SN 85-136,633. WERECYCLE! LLC, MOUNT VERNON, NY.
FILED 9-23-2010.



NO CLAIM IS MADE TO THE EXCLUSIVE RIGHT TO USE "WE RECYCLE", APART FROM THE MARK AS SHOWN.

THE MARK CONSISTS OF INTERTWINED LETTERS "W" AND "R" WITHIN A CIRCLE CENTERED ABOVE THE TEXT "WERECYCLE!".

CLASS 37—CONSTRUCTION AND REPAIR

FOR RECYCLING SERVICES, NAMELY, COLLECTION, REMOVAL AND DISPOSAL OF ELECTRONIC EQUIPMENT, LIGHT BULBS, BATTERIES, BALLASTS, SWITCHES, THERMOSTATS, TONER CARTRIDGES AND MERCURY-CONTAINING EQUIPMENT; REFURBISHMENT OF ELECTRONIC EQUIPMENT AND COMPONENTS; CONSULTING SERVICES IN THE FIELD OF DISPOSAL OF OBSOLETE AND USED ELECTRONIC AND IT EQUIPMENT (U.S. CLS. 100, 103 AND 106).
FIRST USE 1-22-2003; IN COMMERCE 1-22-2003.

CLASS 40—MATERIAL TREATMENT

FOR RECYCLING SERVICES, NAMELY, RECYCLING OF ELECTRONIC AND IT EQUIPMENT, LIGHT BULBS, BATTERIES, BALLASTS, SWITCHES, THERMOSTATS, TONER CARTRIDGES AND MERCURY-CONTAINING EQUIPMENT; RECLAMATION OF ELECTRONIC AND IT EQUIPMENT AND RECYCLING OF WASTE; CONSULTING SERVICES IN THE FIELD OF RECYCLING OF OBSOLETE AND USED ELECTRONIC AND IT EQUIPMENT (U.S. CLS. 100, 103 AND 106).
FIRST USE 1-22-2003; IN COMMERCE 1-22-2003.

CLASS 42—SCIENTIFIC AND COMPUTER SERVICES

FOR TESTING OF ELECTRONIC EQUIPMENT AND COMPONENTS (U.S. CLS. 100 AND 101).
FIRST USE 1-22-2003; IN COMMERCE 1-22-2003.
TRACY CROSS, EXAMINING ATTORNEY

SN 85-136,865. MOXIEQMEDIA, INC., NEW YORK, NY.
FILED 9-23-2010.

A GAY FOR EVERY GIRL

THE MARK CONSISTS OF STANDARD CHARACTERS WITHOUT CLAIM TO ANY PARTICULAR FONT, STYLE, SIZE, OR COLOR.

CLASS 35—ADVERTISING AND BUSINESS

FOR OPERATING A SHOPPING SITE, AVAILABLE VIA THE INTERNET, MOBILE TELEPHONE OR OTHER WIRED OR WIRELESS DIGITAL NETWORKS, OFFERING A VARIETY OF GOODS OF INTEREST TO WOMEN (U.S. CLS. 100, 101 AND 102).

CLASS 41—EDUCATION AND ENTERTAINMENT

FOR PROVIDING INFORMATION, VIA THE INTERNET AND OTHER WIRED AND WIRELESS DIGITAL NETWORKS, IN THE FIELDS OF ENTERTAINMENT, RECREATION, CELEBRITY NEWS, AND THE ARTS (U.S. CLS. 100, 101 AND 107).
MARIA-VICTORIA SUAREZ, EXAMINING ATTORNEY

SN 85-136,914. WAYNETWORKS MARINE, LLC, AUGUSTA, GA. FILED 9-23-2010.

The Ultimate in LiveAboards

THE MARK CONSISTS OF STANDARD CHARACTERS WITHOUT CLAIM TO ANY PARTICULAR FONT, STYLE, SIZE, OR COLOR.

OWNER OF U.S. REG. NO. 1,615,184.
NO CLAIM IS MADE TO THE EXCLUSIVE RIGHT TO USE "LIVEABOARDS" FOR INTERNATIONAL CLASS 39, APART FROM THE MARK AS SHOWN.

CLASS 25—CLOTHING

FOR ATHLETIC APPAREL, NAMELY, SHIRTS, PANTS, JACKETS, FOOTWEAR, HATS AND CAPS, ATHLETIC UNIFORMS (U.S. CLS. 22 AND 39).
FIRST USE 1-1-1985; IN COMMERCE 1-1-1985.

CLASS 39—TRANSPORTATION AND STORAGE

FOR CONDUCTING DIVING CHARTERS (U.S. CLS. 100 AND 105).
FIRST USE 1-1-1985; IN COMMERCE 1-1-1985.
AISHA SALEM, EXAMINING ATTORNEY

CLASS 45—PERSONAL AND LEGAL SERVICES

FOR LICENSING APPLICATIONS TO CUSTOMERS AS A SERVICE ON DEMAND, IN CONNECTION WITH SOFTWARE AS A SERVICE (SAAS) SERVICES (U.S. CLS. 100 AND 101).
FIRST USE 7-0-2008; IN COMMERCE 7-0-2008.
HENRY S. ZAK, EXAMINING ATTORNEY

SN 85-137,403. FIBERCLOUD, INC., SEATTLE, WA. FILED 9-24-2010.

SN 85-137,437. FIBERCLOUD, INC., SEATTLE, WA. FILED 9-24-2010.

FIBERCLOUD

THE MARK CONSISTS OF STANDARD CHARACTERS WITHOUT CLAIM TO ANY PARTICULAR FONT, STYLE, SIZE, OR COLOR.

OWNER OF U.S. REG. NO. 2,655,464.

FIBERCLOUD MATRIX TECHNOLOGY

THE MARK CONSISTS OF STANDARD CHARACTERS WITHOUT CLAIM TO ANY PARTICULAR FONT, STYLE, SIZE, OR COLOR.

OWNER OF U.S. REG. NO. 2,655,464.

NO CLAIM IS MADE TO THE EXCLUSIVE RIGHT TO USE "MATRIX TECHNOLOGY", APART FROM THE MARK AS SHOWN.

CLASS 39—TRANSPORTATION AND STORAGE

FOR PROVIDING STORAGE SPACE FOR ARCHIVING ELECTRONIC DATA (U.S. CLS. 100 AND 105).
FIRST USE 7-0-2008; IN COMMERCE 7-0-2008.

CLASS 39—TRANSPORTATION AND STORAGE

FOR PROVIDING STORAGE SPACE FOR ARCHIVING ELECTRONIC DATA (U.S. CLS. 100 AND 105).
FIRST USE 7-0-2008; IN COMMERCE 7-0-2008.

CLASS 42—SCIENTIFIC AND COMPUTER SERVICES

FOR INTERNET TELECOMMUNICATIONS TECHNOLOGY SERVICES TO ALLOW INTERNET BANDWIDTH TO OTHERS, AND POINT-TO- POINT AND POINT-TO-MULTIPOINT CIRCUITS FOR USE BY OTHERS; CLOUD COMPUTING FEATURING SOFTWARE FOR USE IN HOSTED CLOUD COMPUTING SERVICES AND HOSTED THIRD PARTY PRODUCTS NAMELY SOFTWARE FOR USE IN DATA BACKUP, ENCRYPTED FILE TRANSFER, HOSTED EMAIL, DOCUMENT BACKUP, PRODUCING AND MANAGING DOCUMENTS; COMPUTER SERVICES, NAMELY, HOSTED MANAGEMENT OF CLOUD COMPUTING SYSTEMS AND APPLICATIONS FOR OTHERS; COMPUTER SERVICES, NAMELY, HOSTED MANAGEMENT OF THE INFORMATION TECHNOLOGY (IT) CLOUD COMPUTING SYSTEMS OF OTHERS; TECHNICAL SUPPORT SERVICES, NAMELY, PROVIDING OFF-SITE INFRASTRUCTURE MANAGEMENT SERVICES FOR MONITORING, ADMINISTRATION AND MANAGEMENT OF PUBLIC AND PRIVATE CLOUD COMPUTING INFORMATION TECHNOLOGY (IT) AND APPLICATION SYSTEMS; PROVIDING SECURE CUSTOMER ACCESS TO DATA CENTERS, NAMELY, PROVIDING PHYSICAL ACCESS AND A WEB BASED SERVICE ENABLING INDIVIDUALS TO ACCESS DATA CENTERS; APPLICATION SERVICE PROVIDER (ASP), NAMELY, HOSTING COMPUTER SOFTWARE APPLICATIONS OF OTHERS; HOSTING THE WEB SITES OF OTHERS; COMPUTER HARDWARE AND SOFTWARE CONSULTING SERVICES; CONSULTING SERVICES IN THE FIELD OF HOSTING COMPUTER SOFTWARE APPLICATIONS (U.S. CLS. 100 AND 101).

FIRST USE 7-0-2008; IN COMMERCE 7-0-2008.

CLASS 42—SCIENTIFIC AND COMPUTER SERVICES

FOR INTERNET TELECOMMUNICATIONS TECHNOLOGY SERVICES TO ALLOW INTERNET BANDWIDTH TO OTHERS, AND POINT-TO- POINT AND POINT-TO-MULTIPOINT CIRCUITS FOR USE BY OTHERS; CLOUD COMPUTING FEATURING SOFTWARE FOR USE IN HOSTED CLOUD COMPUTING SERVICES AND HOSTED THIRD PARTY PRODUCTS NAMELY SOFTWARE FOR USE IN DATA BACKUP, ENCRYPTED FILE TRANSFER, HOSTED EMAIL, DOCUMENT BACKUP, PRODUCING AND MANAGING DOCUMENTS; COMPUTER SERVICES, NAMELY, HOSTED MANAGEMENT OF CLOUD COMPUTING SYSTEMS AND APPLICATIONS FOR OTHERS; COMPUTER SERVICES, NAMELY, HOSTED MANAGEMENT OF THE INFORMATION TECHNOLOGY (IT) CLOUD COMPUTING SYSTEMS OF OTHERS; TECHNICAL SUPPORT SERVICES, NAMELY, PROVIDING OFF-SITE INFRASTRUCTURE MANAGEMENT SERVICES FOR MONITORING, ADMINISTRATION AND MANAGEMENT OF PUBLIC AND PRIVATE CLOUD COMPUTING INFORMATION TECHNOLOGY (IT) AND APPLICATION SYSTEMS; PROVIDING SECURE CUSTOMER ACCESS TO DATA CENTERS, NAMELY, PROVIDING PHYSICAL ACCESS AND A WEB BASED SERVICE ENABLING INDIVIDUALS TO ACCESS DATA CENTERS; APPLICATION SERVICE PROVIDER (ASP), NAMELY, HOSTING COMPUTER SOFTWARE APPLICATIONS OF OTHERS; HOSTING THE WEB SITES OF OTHERS; COMPUTER HARDWARE AND SOFTWARE CONSULTING SERVICES; CONSULTING SERVICES IN THE FIELD OF HOSTING COMPUTER SOFTWARE APPLICATIONS (U.S. CLS. 100 AND 101).

FIRST USE 7-0-2008; IN COMMERCE 7-0-2008.

CLASS 45—PERSONAL AND LEGAL SERVICES

FOR LICENSING APPLICATIONS TO CUSTOMERS AS A SERVICE ON DEMAND, IN CONNECTION WITH SOFTWARE AS A SERVICE (SAAS) SERVICES (U.S. CLS. 100 AND 101).

FIRST USE 7-0-2008; IN COMMERCE 7-0-2008.

HENRY S. ZAK, EXAMINING ATTORNEY

SN 85-137,670. COOPERATIVE REGIONS OF ORGANIC PRODUCER POOLS, LA FARGE, WI. FILED 9-24-2010.

FROG TV

THE MARK CONSISTS OF STANDARD CHARACTERS WITHOUT CLAIM TO ANY PARTICULAR FONT, STYLE, SIZE, OR COLOR.

NO CLAIM IS MADE TO THE EXCLUSIVE RIGHT TO USE "TV", APART FROM THE MARK AS SHOWN.

CLASS 41—EDUCATION AND ENTERTAINMENT

FOR ENTERTAINMENT SERVICES, NAMELY, PROVIDING ON-GOING WEBISODES FEATURING FOOD, HEALTH, AND THE ENVIRONMENT VIA A GLOBAL COMPUTER NETWORK (U.S. CLS. 100, 101 AND 107).

CLASS 44—MEDICAL, BEAUTY AND AGRICULTURAL SERVICES

FOR PROVIDING A WEB SITE FEATURING INFORMATION ABOUT FOOD, NAMELY, INFORMATION REGARDING NUTRITION AND DIET; PROVIDING A WEB SITE FEATURING INFORMATION ABOUT HEALTH (U.S. CLS. 100 AND 101).

MARK SHINER, EXAMINING ATTORNEY

SN 85-137,703. PRESTOLITE WIRE LLC, SOUTHFIELD, MI. FILED 9-24-2010.

PRESTOLITE

THE MARK CONSISTS OF STANDARD CHARACTERS WITHOUT CLAIM TO ANY PARTICULAR FONT, STYLE, SIZE, OR COLOR.

OWNER OF U.S. REG. NOS. 2,860,528, 2,970,990 AND OTHERS.

CLASS 7—MACHINERY

FOR MOTOR VEHICLE PRODUCTS, NAMELY, GASKETS FOR INTERNAL COMBUSTION ENGINES, ALTERNATORS, FANS, CRANKSHAFT AND CAM SHAFT KEYS, CAM BUTTONS, RADIATOR CAPS, RADIATOR TANKS, RADIATOR SHROUDS, OIL DIPSTICKS, HEADER BOLTS AND STUDS, COIL COVERS, AIR FILTERS, FLYWHEELS, LOOM SEPARATORS, SOLENOID VALVES FOR MOTOR VEHICLES, DISTRIBUTORS FOR VEHICLES, DISTRIBUTOR CAPS AND CLAMPS, IGNITION WIRE DIVIDERS AND MARKERS, ENGINE PRIMER RODS, ABRASIVE WHEELS AND ROLLS AND GRINDING STONES FOR POWER-OPERATED GRINDERS, CAM SHAFT DEGREE WHEEL PLATES, ENGINE VALVE COVERS, AIR INTAKE SCOOPS FOR MOTOR VEHICLE ENGINES, STARTERS FOR MOTORS AND ENGINES, STARTER MOTORS, DISTRIBUTOR ROTORS FOR INTERNAL COMBUSTION ENGINES, INTAKE MANIFOLDS, ENGINE PILOT BEARINGS, ENGINE MOTOR MOUNTS, CARBURETORS AND COMPONENTS THEREOF, FUEL PUMPS AND COMPONENTS THEREOF, PUMP IMPELLERS, WATER PUMP HOUSINGS AND COMPONENTS THEREOF, OIL FILTERS, INTERNAL ENGINE BEARINGS, ENGINE FASTENERS IN THE NATURE OF NUTS AND BOLTS SPECIALLY ADAPTED TO HOLD AND ASSEMBLE MOTOR VEHICLE ENGINES; ROCKER ARM ADJUSTERS IN THE NATURE OF NUTS, STUDS AND CLIPS SPECIALLY ADAPTED FOR USE WITH ROCKER ARMS; IGNITION CONVERSION KITS FOR POINT DISTRIBUTORS COMPRISED OF AN ELECTRONIC IGNITION MODULE, ADAPTER PLATE, SHUTTER WHEEL AND MOUNTING HARDWARE; PARTS FOR CARBURETORS, NAMELY, POWER VALVES FOR CARBURETORS, NEEDLES, FLOATS AND SEATS, O-RINGS, IDLE SCREWS AND FUEL BOWL WASHERS; MOTOR VEHICLE IGNITION PARTS FOR INTERNAL COMBUSTION ENGINES IN THE NATURE OF IGNITION COILS, IGNITION WIRES, RESISTORS, CONDENSERS, POINTS, IGNITION CONTACT SETS, IGNITION BOXES, CAPACITOR DISCHARGE IGNITIONS, POWER PACKS, SWITCHBOXES, ELECTRONIC IGNITIONS FOR VEHICLES AND IGNITION MAGNETOS FOR MOTOR VEHICLE ENGINES; PARTS OF FUEL INJECTION SYSTEMS, NAMELY, FUEL INJECTORS, FUEL FILTERS AND FUEL FITTINGS FOR CONNECTING FUEL LINES TO FUEL SYSTEM PARTS (U.S. CLS. 13, 19, 21, 23, 31, 34 AND 35).

CLASS 9—ELECTRICAL AND SCIENTIFIC APPARATUS

FOR WIRE, NAMELY, ELECTRIC WIRES; POWER CABLES AND ELECTRIC CABLES; BATTERIES; BATTERY CABLES; MOTOR VEHICLE FUEL PRESSURE GAUGES; SOFTWARE FOR TUNING FUEL INJECTION SYSTEMS FOR MOTOR VEHICLES; ELECTRONIC TUNERS FOR FUEL INJECTION SYSTEMS FOR MOTOR VEHICLES; ENGINE SPEED LIMITERS, NAMELY, ENGINE SPEED CONTROLLERS; ELECTRICAL COMPONENTS AND ELECTRICAL CONTROLS FOR MOTOR VEHICLES, NAMELY, VOLTAGE REGULATORS AND RECTIFIERS AND COMBUSTION LEAKAGE TESTERS (U.S. CLS. 21, 23, 26, 36 AND 38).

CLASS 12—VEHICLES

FOR MOTOR VEHICLE PARTS, NAMELY, METALLIC FUEL HOSES, DOOR LOCK KNOBS, HOOD PINS, FITTED REAR END COVERS, FUEL LINES, TRANSMISSION MOUNTS, THROTTLE PEDALS, CLUTCH LINKAGES, COIL SPRING BOOSTERS, RING GEAR SPACERS, STARTER SHIELDS, TRANSMISSION PAN COVERS, CLUTCHES FOR MOTOR VEHICLES AND PARTS THEREOF, CLUTCH DISKS, DRIVE SHAFT SAFETY LOOPS, MOTOR MOUNTS AND PARTS THEREOF, BRAKE ROTORS FOR LAND VEHICLES, COVERS FOR VEHICLE TRANSMISSION PARTS IN THE NATURE OF BELL HOUSINGS, VEHICLE SUSPENSION PARTS IN THE NATURE OF TRACTION BARS, LADDER BARS AND SHOCKS AND STRUTS; CLUTCH KITS COMPRISING THE FOLLOWING SOLD AS A UNIT, NAMELY, CLUTCH PARTS FOR MOTOR VEHICLES AND TOOLS AND INSTRUCTIONS FOR INSTALLING THE SAME; STRUCTURAL MOTOR VEHICLE PRODUCTS, NAMELY, SHIFTERS AND PARTS THEREOF; HOUSE MARK FOR MOTOR VEHICLE PARTS, NAMELY, SUSPENSION AND DRIVE TRAIN PARTS (U.S. CLS. 19, 21, 23, 31, 35 AND 44).

MARK SHINER, EXAMINING ATTORNEY

CLASS 37—CONSTRUCTION AND REPAIR

FOR PRESSURE GROUTING SERVICES, NAMELY, MUDJACKING AND SLABJACKING; INSTALLATION AND REPAIR OF DECORATIVE CONCRETE FOR COMMERCIAL AND RESIDENTIAL BUILDINGS; APPLICATION OF PROTECTIVE OR DECORATIVE COATINGS TO DECORATIVE CONCRETE ON COMMERCIAL AND RESIDENTIAL BUILDINGS; FOUNDATION CONTRACTOR SERVICES (U.S. CLS. 100, 103 AND 106).

CLASS 40—MATERIAL TREATMENT

FOR CONCRETE STAINING SERVICES (U.S. CLS. 100, 103 AND 106).

DAVID H. STINE, EXAMINING ATTORNEY

SN 85-137,790. PARROT STRUCTURAL SERVICES, LLC, CALERA, AL. FILED 9-24-2010.

SN 85-137,746. PARROT STRUCTURAL SERVICES, LLC, CALERA, AL. FILED 9-24-2010.

IF YOUR CONCRETE SINKS
DON'T HAVE A TRAUMA, JUST
PICK UP THE PHONE AND CALL
YA MAMA

THE MARK CONSISTS OF STANDARD CHARACTERS WITHOUT CLAIM TO ANY PARTICULAR FONT, STYLE, SIZE, OR COLOR.

CLASS 37—CONSTRUCTION AND REPAIR

FOR PRESSURE GROUTING SERVICES, NAMELY, MUDJACKING AND SLABJACKING; INSTALLATION AND REPAIR OF DECORATIVE CONCRETE FOR COMMERCIAL AND RESIDENTIAL BUILDINGS; APPLICATION OF PROTECTIVE COATINGS TO DECORATIVE CONCRETE ON COMMERCIAL AND RESIDENTIAL BUILDINGS; FOUNDATION CONTRACTOR SERVICES (U.S. CLS. 100, 103 AND 106).

CLASS 40—MATERIAL TREATMENT

FOR CONCRETE STAINING SERVICES (U.S. CLS. 100, 103 AND 106).

DAVID H. STINE, EXAMINING ATTORNEY

CLASS 37—CONSTRUCTION AND REPAIR

FOR PRESSURE GROUTING SERVICES, NAMELY, MUDJACKING AND SLABJACKING; INSTALLATION AND REPAIR OF DECORATIVE CONCRETE FOR COMMERCIAL AND RESIDENTIAL BUILDINGS; APPLICATION OF PROTECTIVE OR DECORATIVE COATINGS TO DECORATIVE CONCRETE ON COMMERCIAL AND RESIDENTIAL BUILDINGS; FOUNDATION CONTRACTOR SERVICES (U.S. CLS. 100, 103 AND 106).

CLASS 40—MATERIAL TREATMENT

FOR CONCRETE STAINING SERVICES (U.S. CLS. 100, 103 AND 106).

DAVID H. STINE, EXAMINING ATTORNEY

SN 85-139,056. UNILEVER N.V., ROTTERDAM 3013 AL, NETHERLANDS, FILED 9-27-2010.

SN 85-137,768. PARROT STRUCTURAL SERVICES, LLC, CALERA, AL. FILED 9-24-2010.

CALL YA MAMA

THE MARK CONSISTS OF STANDARD CHARACTERS WITHOUT CLAIM TO ANY PARTICULAR FONT, STYLE, SIZE, OR COLOR.

YA MAMA

THE MARK CONSISTS OF STANDARD CHARACTERS WITHOUT CLAIM TO ANY PARTICULAR FONT, STYLE, SIZE, OR COLOR.



OWNER OF U.S. REG. NOS. 3,107,051, 3,641,169 AND 3,647,941.

NO CLAIM IS MADE TO THE EXCLUSIVE RIGHT TO USE "FOOD", APART FROM THE MARK AS SHOWN.

THE MARK CONSISTS OF A STYLIZED LETTER "U" COMPRISED OF A STYLIZED BIRD, FISH, FLOWERS, SPOON AND OTHER FANCIFUL DESIGNS, NEXT TO THE VERTICALLY ARRANGED WORDS, "UNILEVER FOOD SOLUTIONS".

CLASS 29—MEATS AND PROCESSED FOODS

FOR MEAT, FISH, POULTRY AND GAME; MEAT EXTRACTS, PRESERVED, DRIED AND COOKED FRUITS AND VEGETABLES; JELLIES, MILK AND DAIRY PRODUCTS EXCLUDING ICE CREAM, ICE MILK AND FROZEN YOGURT; EDIBLE OILS AND FATS; SOUPS; MIXES FOR MAKING SOUPS; SOUP CONCENTRATES; BOUILLON; BROTH MIXES; PEANUT BUTTER; FRUIT OR VEGETABLE-BASED SPREADS; DIPS; DIP MIXES; FRUIT-BASED FILLING FOR CAKES AND PIES (U.S. CL. 46).

CLASS 30—STAPLE FOODS

FOR TEA; PASTRY; BAKING-POWDER; MUSTARD; SAUCES; MIXES FOR MAKING SAUCES; SPICES; MAYONNAISE; KETCHUP; SALAD DRESSINGS; SEASONINGS; GLAZES; BAKERY DESSERTS; PASTRY MIXES; MIXES FOR BAKERY GOODS; MOUSSE MIXES; FLAN MIXES; ICE CREAM MIXES; PUDDING MIXES; CHOCOLATE OR CUSTARD-BASED FILLINGS FOR CAKES AND PIES; SEASONING MIXES; GRAVIES; GRAVY MIXES; MARINADE MIXES (U.S. CL. 46).

CLASS 32—LIGHT BEVERAGES

FOR MINERAL AND AERATED WATERS; SOFT DRINKS; FRUIT DRINKS; FRUIT JUICES; SYRUPS AND SYRUP SUBSTITUTES FOR MAKING BEVERAGES; ESSENCES FOR MAKING NON-ALCOHOLIC BEVERAGES (U.S. CLS. 45, 46 AND 48).

CLASS 35—ADVERTISING AND BUSINESS

FOR PROVIDING CONSUMER INFORMATION IN THE FIELD OF FOOD PRODUCTS IN THE FOOD SERVICE INDUSTRY AND PROVIDING INFORMATION REGARDING CONSUMER TRENDS IN THE FOOD SERVICE INDUSTRY (U.S. CLS. 100, 101 AND 102).

CLASS 43—HOTEL AND RESTAURANT SERVICES

FOR PROVIDING OF FOOD AND DRINK; PROVIDING CONSULTING AND INFORMATION TO FOOD AND BEVERAGE PROVIDERS CONCERNING THE PREPARATION OF FOOD AND BEVERAGES; PROVIDING INFORMATION CONCERNING COOKING, RECIPES AND INGREDIENTS (U.S. CLS. 100 AND 101).

CLASS 44—MEDICAL, BEAUTY AND AGRICULTURAL SERVICES

FOR PROVIDING DIETARY AND NUTRITIONAL INFORMATION REGARDING FOOD PRODUCTS (U.S. CLS. 100 AND 101).

IRA J. GOODSaid, EXAMINING ATTORNEY

SN 85-140,576. GOOBER NETWORKS, INC., DOVER, DE. FILED 9-29-2010.

FaceTalk

THE MARK CONSISTS OF STANDARD CHARACTERS WITHOUT CLAIM TO ANY PARTICULAR FONT, STYLE, SIZE, OR COLOR.

CLASS 9—ELECTRICAL AND SCIENTIFIC APPARATUS

FOR CELLULAR TELEPHONES; COMPUTER SOFTWARE TO ENABLE THE TRANSMISSION OF PHOTOGRAPHS TO MOBILE TELEPHONES; COMPUTER TELEPHONY SOFTWARE; CONTINGENCY RESPONSE COMMUNICATION SYSTEM DESIGNED TO PROVIDE RADIO INTEROPERABILITY, STREAMING VIDEO, WIRELESS INTERNET, AND VOIP PHONE; INTEROPERABLE COMMUNICATION SYSTEM DESIGNED TO PROVIDE RADIO, STREAMING VIDEO, WIRELESS INTERNET, AND VOIP PHONE; TELEPHONE CALL ROUTER, FOR HOME AND OFFICE TOUCHTONE PHONES, FOR INTERNATIONAL AND LONG DISTANCE CALLS MADE FROM VARIOUS TELEPHONY PLATFORMS INCLUDING VOIP PLATFORM WITHOUT THE REQUIREMENT FOR INTERNET (U.S. CLS. 21, 23, 26, 36 AND 38).

CLASS 35—ADVERTISING AND BUSINESS

FOR ADVERTISING BUSINESS ESPECIALLY IN THE FIELD OF TELEMATIC AND TELEPHONE NETWORKS (U.S. CLS. 100, 101 AND 102).

CLASS 42—SCIENTIFIC AND COMPUTER SERVICES

FOR DESIGN OF UNIFIED COMMUNICATIONS SERVICES; TELEPHONE NUMBER MAPPING SERVICES FOR UNIFYING THE TELEPHONE NUMBER SYSTEM WITH INTERNET ADDRESSING AND IDENTIFICATION SYSTEMS (U.S. CLS. 100 AND 101).

BARBARA A. GOLD, EXAMINING ATTORNEY

SN 85-141,120. BRITTO CENTRAL, INC., MIAMI BEACH, FL. FILED 9-29-2010.



THE COLOR(S) BLACK, WHITE, RED, ORANGE, BLUE, YELLOW, PURPLE, PINK IS/ARE CLAIMED AS A FEATURE OF THE MARK.

THE MARK CONSISTS OF A STYLIZED WINGED HEART IN WHITE, RED, ORANGE, BLUE, YELLOW, PURPLE AND PINK AND OUTLINED IN BLACK.

CLASS 6—METAL GOODS

FOR SCULPTURES OF METAL (U.S. CLS. 2, 12, 13, 14, 23, 25 AND 50).

FIRST USE 0-0-1987; IN COMMERCE 0-0-1987.

CLASS 16—PAPER GOODS AND PRINTED MATTER

FOR PAINTINGS; POSTERS; AND ART PRINTS (U.S. CLS. 2, 5, 22, 23, 29, 37, 38 AND 50).

FIRST USE 0-0-1987; IN COMMERCE 0-0-1987.

CLASS 20—FURNITURE AND ARTICLES NOT OTHERWISE CLASSIFIED

FOR SCULPTURES OF WOOD; SCULPTURES OF RESIN (U.S. CLS. 2, 13, 22, 25, 32 AND 50).
FIRST USE 0-0-1987; IN COMMERCE 0-0-1987.

CLASS 42—SCIENTIFIC AND COMPUTER SERVICES

FOR COMMERCIAL ARTISTIC DESIGN SERVICES FOR OTHERS IN THE FIELD OF COMMISSIONED ARTWORKS (U.S. CLS. 100 AND 101).
FIRST USE 0-0-1987; IN COMMERCE 0-0-1987.
TRACY CROSS, EXAMINING ATTORNEY

SN 85-141,519. HEALTHDARE, LLC, CEDAR RAPIDS, IA.
FILED 9-29-2010.



THE STIPLING IS FOR SHADING PURPOSES ONLY.
THE MARK CONSISTS OF 5 ICONS BELOW THE WORD "HEALTHDARE": 1) SQUARE WITH RUNNER; 2) SQUARE WITH APPLE; 3) SQUARE WITH DROP OF WATER; 4) SQUARE WITH A BELL BAR WEIGHT; 5) SQUARE WITH A WEIGHT SCALE. UNDERNEATH THE 5 ICONS AND OFFSET TO THE RIGHT IS "HEALTHDARE.COM".

CLASS 42—SCIENTIFIC AND COMPUTER SERVICES

FOR PROVIDING A WEBSITE FEATURING AN ON-LINE TOOL IN THE NATURE OF NON-DOWNLOADABLE SOFTWARE THAT ALLOWS GROUPS OF PEOPLE TO PARTICIPATE IN A WELLNESS CHALLENGE, AND ALLOWS PARTICIPANTS TO MONITOR EACH OTHERS PROGRESS (U.S. CLS. 100 AND 101).

CLASS 45—PERSONAL AND LEGAL SERVICES

FOR ON-LINE SOCIAL NETWORKING SERVICES (U.S. CLS. 100 AND 101).
PRISCILLA MILTON, EXAMINING ATTORNEY

SN 85-141,644. BRINKER TECHNOLOGY LIMITED, ABERDEEN, UNITED KINGDOM, FILED 9-30-2010.

EXPERIENCE THE UPSIDE

THE MARK CONSISTS OF STANDARD CHARACTERS WITHOUT CLAIM TO ANY PARTICULAR FONT, STYLE, SIZE, OR COLOR.

OWNER OF UNITED KINGDOM REG. NO. 2543423, DATED 8-6-2010, EXPIRES 3-30-2020.

CLASS 6—METAL GOODS

FOR METAL SEALS FOR USE IN THE OIL AND GAS EXPLORATION, EXTRACTION, PRODUCTION, DISTRIBUTION AND EXPLOITATION INDUSTRIES, THE PHARMACEUTICAL INDUSTRY, THE CHEMICAL INDUSTRY, THE AUTOMOTIVE INDUSTRY AND THE PROCESSING PLANTS AND PLANT, AND INDUSTRIAL AND MANUFACTURING INDUSTRIES; METAL SEALS FOR PIPES, PIPELINES, PIPELINE SYSTEMS, RISERS, LINERS, CASINGS, TANKS, STORAGE TANKS, BALLAST TANKS, VALVES, VALVE ASSEMBLIES, MANIFOLDS, UMBILICALS, CLAMPS, WELLHEADS AND OTHER PRESSURISED SYSTEMS, AND COUPLINGS THEREFOR, USED IN THE OIL AND GAS EXPLORATION, EXTRACTION, PRODUCTION, DISTRIBUTION AND EXPLOITATION INDUSTRIES, THE PHARMACEUTICAL INDUSTRY, THE CHEMICAL INDUSTRY, THE AUTOMOTIVE INDUSTRY AND THE PROCESSING PLANTS AND PLANT, AND INDUSTRIAL AND MANUFACTURING INDUSTRIES; SEALS OF METAL FOR PREVENTING LEAKAGE OF FLUIDS FOR USE IN THE OIL AND GAS EXPLORATION, EXTRACTION, PRODUCTION, DISTRIBUTION AND EXPLOITATION INDUSTRIES, THE PHARMACEUTICAL INDUSTRY, THE CHEMICAL INDUSTRY, THE AUTOMOTIVE INDUSTRY AND THE PROCESSING PLANTS AND PLANT, AND INDUSTRIAL AND MANUFACTURING INDUSTRIES; DISCRETE SEALING ELEMENTS OF METAL, NAMELY, METAL BALLS, METAL TUBES, AND METAL CYLINDERS FOR USE IN THE OIL AND GAS EXPLORATION, EXTRACTION, PRODUCTION, DISTRIBUTION AND EXPLOITATION INDUSTRIES, THE PHARMACEUTICAL INDUSTRY, THE CHEMICAL INDUSTRY, THE AUTOMOTIVE INDUSTRY AND THE PROCESSING PLANTS AND PLANT, AND INDUSTRIAL AND MANUFACTURING INDUSTRIES; DISCRETE SEALING ELEMENTS OF METAL FOR STOPPING LEAKAGE FROM PIPES, PIPELINES, PIPELINE SYSTEMS, RISERS, LINERS, CASINGS, TANKS, STORAGE TANKS, BALLAST TANKS, VALVES, VALVE ASSEMBLIES, MANIFOLDS, UMBILICALS, CLAMPS, WELLHEADS AND OTHER PRESSURISED SYSTEMS, AND COUPLINGS THEREFOR, NAMELY, METAL BALLS, METAL TUBES, AND METAL CYLINDERS, USED IN THE OIL AND GAS EXPLORATION, EXTRACTION, PRODUCTION, DISTRIBUTION AND EXPLOITATION INDUSTRIES, THE PHARMACEUTICAL INDUSTRY, THE CHEMICAL INDUSTRY, THE AUTOMOTIVE INDUSTRY AND THE PROCESSING PLANTS AND PLANT, AND INDUSTRIAL AND MANUFACTURING INDUSTRIES; DISCRETE ELEMENTS FOR TEMPORARY BLOCKAGE OF PIPES, PIPELINES, PIPELINE SYSTEMS, RISERS, LINERS, CASINGS, TANKS, STORAGE TANKS, BALLAST TANKS, VALVES, VALVE ASSEMBLIES, MANIFOLDS, UMBILICALS, CLAMPS, WELLHEADS AND OTHER PRESSURISED SYSTEMS, AND COUPLINGS THEREFOR, NAMELY, METAL BALLS, METAL TUBES, AND METAL CYLINDERS, USED IN THE OIL AND GAS EXPLORATION, EXTRACTION, PRODUCTION, DISTRIBUTION AND EXPLOITATION INDUSTRIES, THE PHARMACEUTICAL INDUSTRY, THE CHEMICAL INDUSTRY, THE AUTOMOTIVE INDUSTRY AND THE PROCESSING PLANTS AND PLANT, AND INDUSTRIAL AND MANUFACTURING INDUSTRIES; DISCRETE ELEMENTS TO FACILITATE INVESTIGATION OF PIPES, PIPELINES, PIPELINE SYSTEMS, RISERS, LINERS, CASINGS, TANKS, STORAGE TANKS, BALLAST TANKS, VALVES, VALVE ASSEMBLIES, MANIFOLDS, UMBILICALS, CLAMPS, WELLHEADS AND OTHER PRESSURISED SYSTEMS, AND COUPLINGS THEREFOR, NAMELY, METAL BALLS, METAL TUBES, AND METAL CYLINDERS, USED IN THE OIL AND GAS EXPLORATION, EXTRACTION, PRODUCTION, DISTRIBUTION AND EXPLOITATION INDUSTRIES, THE PHARMACEUTICAL INDUSTRY, THE CHEMICAL INDUSTRY, THE AUTOMOTIVE INDUSTRY AND THE PROCESSING PLANTS AND PLANT, AND INDUSTRIAL AND MANUFACTURING INDUSTRIES; STRUCTURAL PARTS, FOR THE AFORESAID GOODS (U.S. CLS. 2, 12, 13, 14, 23, 25 AND 50).

COUPLINGS THEREFOR; DISCRETE SEALING ELEMENTS OF POLYMER MATERIAL FOR STOPPING LEAKAGE FROM PIPES, PIPELINES, PIPELINE SYSTEMS, RISERS, LINERS, CASINGS, TANKS, STORAGE TANKS, BALLAST TANKS, VALVES, VALVE ASSEMBLIES, MANIFOLDS, UMBILICALS, CLAMPS, WELLHEADS AND OTHER PRESSURISED SYSTEMS, AND COUPLINGS THEREFOR; DISCRETE SEALING ELEMENTS OF RUBBER MATERIAL FOR STOPPING LEAKAGE FROM PIPES, PIPELINES, PIPELINE SYSTEMS, RISERS, LINERS, CASINGS, TANKS, STORAGE TANKS, BALLAST TANKS, VALVES, VALVE ASSEMBLIES, MANIFOLDS, UMBILICALS, CLAMPS, WELLHEADS AND OTHER PRESSURISED SYSTEMS, AND COUPLINGS THEREFOR; DISCRETE ELEMENTS MANUFACTURED FROM POLYMER, RUBBER, PLASTIC AND OTHER NON METAL MATERIALS FOR TEMPORARY BLOCKAGE AND INVESTIGATION OF PIPES, PIPELINES, PIPELINE SYSTEMS, RISERS, LINERS, CASINGS, TANKS, STORAGE TANKS, BALLAST TANKS, VALVES, VALVE ASSEMBLIES, MANIFOLDS, UMBILICALS, CLAMPS, WELLHEADS AND OTHER PRESSURISED SYSTEMS, AND COUPLINGS THEREFOR; PLASTIC MATERIALS IN THE NATURE OF SEALS FOR USE AS SEALS IN CIVIL AND MECHANICAL ENGINEERING; POLYMERS IN THE NATURE OF SEALS FOR USE AS SEALS IN CIVIL AND MECHANICAL ENGINEERING; PLASTIC MATERIALS IN THE FORM OF SMALL PLASTIC SHEETS OR PIECES FOR INTRODUCTION INTO PIPES, PIPELINES, PIPELINE SYSTEMS, RISERS, LINERS, CASINGS, TANKS, STORAGE TANKS, BALLAST TANKS, VALVES, VALVE ASSEMBLIES, MANIFOLDS, UMBILICALS, CLAMPS, WELLHEADS AND OTHER PRESSURISED SYSTEMS, AND COUPLINGS THEREFOR TO INVESTIGATE FLUID FLOW THEREIN; PLASTIC MATERIALS FOR USE AS TEMPORARY BLOCKAGES IN CIVIL AND MECHANICAL ENGINEERING; STRUCTURAL PARTS, FOR THE AFORESAID GOODS (U.S. CLS. 1, 5, 12, 13, 35 AND 50).

CLASS 37—CONSTRUCTION AND REPAIR

FOR MAINTENANCE AND REPAIR OF PIPES, PIPELINES, PIPELINE SYSTEMS, RISERS, LINERS, CASINGS, TANKS, STORAGE TANKS, BALLAST TANKS, VALVES, VALVE ASSEMBLIES, MANIFOLDS, UMBILICALS, CLAMPS, WELLHEADS AND OTHER PRESSURISED SYSTEMS, AND COUPLINGS THEREFOR CONSULTING IN THE FIELD OF MAINTENANCE, REPAIR OF PIPES, PIPELINES, PIPELINE SYSTEMS, RISERS, LINERS, CASINGS, TANKS, STORAGE TANKS, BALLAST TANKS, VALVES, VALVE ASSEMBLIES, MANIFOLDS, UMBILICALS, CLAMPS, WELLHEADS AND OTHER PRESSURISED SYSTEMS, AND COUPLINGS THEREFOR (U.S. CLS. 100, 103 AND 106).

CLASS 42—SCIENTIFIC AND COMPUTER SERVICES

FOR SCIENTIFIC RESEARCH AND TECHNOLOGICAL DESIGN SERVICES IN THE FIELD OF TECHNOLOGY FOR THE INVESTIGATION OF PIPES, PIPELINES, PIPELINE SYSTEMS, RISERS, LINERS, CASINGS, TANKS, STORAGE TANKS, BALLAST TANKS, VALVES, VALVE ASSEMBLIES, MANIFOLDS, UMBILICALS, CLAMPS, WELLHEADS AND OTHER PRESSURIZED SYSTEMS, AND COUPLINGS THEREFOR, FOR DETECTING AND LOCATING HOLES OR LEAKS IN PIPES, PIPELINES, PIPELINE SYSTEMS, RISERS, LINERS, CASINGS, TANKS, STORAGE TANKS, BALLAST TANKS, VALVES, VALVE ASSEMBLIES, MANIFOLDS, UMBILICALS, CLAMPS, WELLHEADS AND OTHER PRESSURIZED SYSTEMS, AND COUPLINGS THEREFOR, AND FOR DETECTING OR MONITORING FLOW OR FLOW CHARACTERISTICS AND FLOW DYNAMICS IN PIPES, PIPELINES, PIPELINE SYSTEMS, RISERS, LINERS, CASINGS, TANKS, STORAGE TANKS, BALLAST TANKS, VALVES, VALVE ASSEMBLIES, MANIFOLDS, UMBILICALS, CLAMPS, WELLHEADS AND OTHER PRESSURIZED SYSTEMS, AND COUPLINGS THEREFOR; INDUSTRIAL AND TECHNICAL INSPECTION SERVICES IN THE FIELD OF THE OIL AND GAS EXPLORATION, EXTRACTION, PRODUCTION, DISTRIBUTION AND EXPLOITATION INDUSTRIES, THE PHARMACEUTICAL INDUSTRY, THE CHEMICAL INDUSTRY, THE AUTOMOTIVE INDUS-

TRY AND THE PROCESSING PLANTS AND PLANT, AND INDUSTRIAL AND MANUFACTURING INDUSTRIES; INSPECTION OF PIPES, PIPELINES, PIPELINE SYSTEMS, RISERS, LINERS, CASINGS, TANKS, STORAGE TANKS, BALLAST TANKS, VALVES, VALVE ASSEMBLIES, MANIFOLDS, UMBILICALS, CLAMPS, WELLHEADS AND OTHER PRESSURIZED SYSTEMS, AND COUPLINGS THEREFOR; ENGINEERING; COMPUTER MODELLING SERVICES, NAMELY, COMPUTER SIMULATION FROM COMPUTER PROGRAMS FOR OTHERS; ENGINEERING DESIGN, ENGINEERING CONSULTANCY AND ENGINEERING PROJECT MANAGEMENT SERVICES IN RELATION TO COMPUTATIONAL FLUID DYNAMICS; ENGINEERING SERVICES, NAMELY, FINITE ELEMENT ANALYSIS; ENGINEERING SERVICES, NAMELY, NUMERICAL MODELLING; COMPUTER MODELLING SERVICES, NAMELY, 1-, 2- AND 3-D MODELLING; ENGINEERING SERVICES, NAMELY, COMPUTATIONAL MECHANICS; MECHANICAL ENGINEERING; STRUCTURAL ENGINEERING, COMPUTER MODELLING, ENGINEERING DESIGN, ENGINEERING CONSULTANCY AND ENGINEERING PROJECT MANAGEMENT SERVICES ALL PROVIDED IN RELATION TO PROCESS OPTIMIZATION, FLOW ASSURANCE, HAZARD QUANTIFICATION, MARINE ENGINEERING, ENVIRONMENTAL PERFORMANCE, ADVANCED STRUCTURAL DESIGN, AND PIPELINE FLOW AND PRESSURE ANALYSIS IN THE OIL AND GAS EXPLORATION, EXTRACTION, PRODUCTION, DISTRIBUTION AND EXPLOITATION INDUSTRIES, THE PHARMACEUTICAL INDUSTRY, THE CHEMICAL INDUSTRY, THE AUTOMOTIVE INDUSTRY AND THE PROCESSING PLANTS AND PLANT, AND INDUSTRIAL AND MANUFACTURING INDUSTRIES; PROVISION OF INTEGRITY MANAGEMENT SERVICES IN THE OIL AND GAS EXPLORATION, EXTRACTION, PRODUCTION, DISTRIBUTION AND EXPLOITATION INDUSTRIES, THE PHARMACEUTICAL INDUSTRY, THE CHEMICAL INDUSTRY, THE AUTOMOTIVE INDUSTRY AND THE PROCESSING PLANTS AND PLANT, AND INDUSTRIAL AND MANUFACTURING INDUSTRIES; ENGINEERING SERVICES IN RELATION TO THE DETECTION, LOCATION, SIZING AND SEALING OF LEAKS IN PIPES, PIPELINES, PIPELINE SYSTEMS, RISERS, LINERS, CASINGS, TANKS, STORAGE TANKS, BALLAST TANKS, VALVES, VALVE ASSEMBLIES, MANIFOLDS, UMBILICALS, CLAMPS, WELLHEADS AND OTHER PRESSURIZED SYSTEMS, AND COUPLINGS THEREFOR (U.S. CLS. 100 AND 101).

CAROLYN CATALDO, EXAMINING ATTORNEY

SN 85-141,840. KABUSHIKI KAISHA NAKASHIMATO SHOTEN, TA NAKASHIMATO CO., LTD., SHIBUYA-KU, TOKYO, JAPAN, FILED 9-30-2010.



OWNER OF JAPAN REG. NO. 4367235, DATED 3-10-2000, EXPIRES 3-10-2020.

OWNER OF U.S. REG. NO. 1,940,200.

THE MARK CONSISTS OF JAPANESE CHARACTERS WHICH TRANSLITERATE INTO AOHATA.

THE ENGLISH TRANSLATION OF THE JAPANESE CHARACTERS IN THE MARK IS BLUE FLAG OR BLUE BANNER.

THE NON-LATIN CHARACTERS IN THE MARK TRANSLITERATE TO AOHATA AND THIS MEANS BLUE FLAG OR BLUE BANNER IN ENGLISH.

CLASS 29—MEATS AND PROCESSED FOODS

FOR JAMS; PEANUT BUTTER; CHOCOLATE SPREAD; BLACK SESAME SPREAD; TOASTED SOY-BEAN FLOUR SPREAD; CORN SOUP; ONION SOUP; MINISTRONE SOUP; SOUPS; CLAM CHOWDER; CANNED CORN; CANNED CREAMY CORN; CANNED PORK AND BEANS; LIVER PASTE; BEEF PASTE; MEAT PASTE; ANCHOVY FILLETS; FISH FILLETS (U.S. CL. 46).

CLASS 30—STAPLE FOODS

FOR RICE PORRIDGE (U.S. CL. 46).
GENE MACIOL, EXAMINING ATTORNEY

SN 85-142,071. BILLIONTON SYSTEMS INC., HSIN-CHU, TAIWAN, FILED 9-30-2010.



SN 85-141,949. ATTORNEYS' TITLE INSURANCE FUND, ORLANDO, FL. FILED 9-30-2010.

THE FUND

THE MARK CONSISTS OF STANDARD CHARACTERS WITHOUT CLAIM TO ANY PARTICULAR FONT, STYLE, SIZE, OR COLOR.

OWNER OF U.S. REG. NO. 1,613,190.

CLASS 36—INSURANCE AND FINANCIAL

FOR INSURANCE SERVICES, NAMELY, PROVIDING AN INTERNET WEBSITE, INTERNET WEBSITE PORTAL INFORMATION, ON-LINE COMPUTER DATABASES, AND DOWNLOADABLE AND NON-DOWNLOADABLE SOFTWARE IN THE FIELDS OF TITLE INSURANCE UNDERWRITING SERVICES, REAL ESTATE TRANSACTION SERVICES, AND REAL ESTATE CLOSING SERVICES; INSURANCE CONSULTANCY SERVICES, NAMELY, PROVIDING INFORMATION ON A VARIETY OF TOPICS IN THE FIELDS OF TITLE INSURANCE UNDERWRITING SERVICES, REAL ESTATE TRANSACTION SERVICES, AND REAL ESTATE CLOSING SERVICES; PROVIDING TITLE INSURANCE UNDERWRITING SERVICES (U.S. CLS. 100, 101 AND 102).

FIRST USE 0-0-1962; IN COMMERCE 0-0-1988.

CLASS 45—PERSONAL AND LEGAL SERVICES

FOR PROVIDING INFORMATION ON A VARIETY OF TOPICS IN THE FIELD OF REAL ESTATE LAW (U.S. CLS. 100 AND 101).

FIRST USE 0-0-1962; IN COMMERCE 0-0-1988.
MICHAEL ENGEL, EXAMINING ATTORNEY

THE MARK CONSISTS OF THE TERM "HOO E" IN STYLIZED LETTERS AND A LOGO ELEMENT TO THE LEFT OF THE LETTERS CONSISTING OF A CIRCLE AND THREE CURVILINEAR TRIANGLES RADIATING FROM THE CIRCLE, THE LAST OF WHICH SWEEPS ACROSS THE BOTTOM OF THE LETTER "H".

CLASS 9—ELECTRICAL AND SCIENTIFIC APPARATUS

FOR ELECTRONIC ADVERTISING MACHINES, NAMELY, ELECTRONIC ADVERTISEMENT AND MESSAGING DISPLAY UNITS WITH MULTI-NETWORKING (TCP/IP) CAPABILITIES AND REMOTE CONNECTIVITY; COMPUTER HARDWARE; INTERFACE CARDS FOR COMPUTERS, NAMELY, INTERFACE CARDS FOR DATA PROCESSING EQUIPMENT IN THE FORM OF PRINTED CIRCUITS; COMPUTER MEMORIES; BLANK HARD DISKS; DATA STORAGES, NAMELY, BLANK TAPES FOR STORAGE OF COMPUTER DATA; PERSONAL DIGITAL ASSISTANT DEVICES (PDA); BLANK MAGNETIC DATA CARRIERS; BLANK OPTICAL DATA CARRIERS; DIGITAL CAMERAS; DIGITAL MEDIA PLAYERS; DIGITAL PHOTO FRAMES FOR DISPLAYING DIGITAL PICTURES, VIDEO CLIPS AND MUSIC; LIGHT EMITTING DIODES; SIGNAL TRANSCEIVERS; INTERNET EQUIPMENT, NAMELY, LIQUID CRYSTAL DISPLAY (LCD) MONITORS, VIDEO PHONES AND VIDEO CAMERAS; NETWORK ROUTERS; USB CABLES; COMPUTER NETWORK ADAPTERS; COMPUTER STORAGE DEVICES, NAMELY, BLANK FLASH DRIVES; ELECTRIC CONNECTORS; SECURITY LIGHTS FOR OUTDOOR USE; MOTION SENSITIVE SECURITY LIGHTS (U.S. CLS. 21, 23, 26, 36 AND 38).

CLASS 11—ENVIRONMENTAL CONTROL APPARATUS

FOR LIGHTS FOR ILLUMINATING STAIRS, DOORS AND OTHER PORTIONS OF BUILDINGS; LIGHT BULBS, DESK LAMPS, RECESSED LAMPS, FLUORESCENT LAMPS, DECORATIVE LIGHTS, NAMELY, LIGHTED PARTY-THEMED DECORATIONS, ELECTRIC LIGHT DECORATIVE STRINGS; FLASHLIGHTS; ART LAMPS; ELECTRIC LIGHTS FOR CHRISTMAS TREES; STAGE LIGHTS FOR THEATRICAL USE; ELECTRIC NIGHT LIGHTS, PROJECTION LAMPS, LAMP SHADES, TABLE LAMPS, ELECTRIC LIGHTS, WALL LAMPS, LIGHT EMITTING DIODE (LED) LIGHTS, LIGHTING APPARATUS FOR VEHICLES, LIGHT EMITTING DIODE (LED) CAR LAMPS (U.S. CLS. 13, 21, 23, 31 AND 34).

REBECCA SMITH, EXAMINING ATTORNEY

SN 85-142,357. ATTORNEYS' TITLE INSURANCE FUND, ORLANDO, FL. FILED 9-30-2010.

SN 85-142,487. ANTEA USA, INC., SHOREVIEW, MN. FILED 9-30-2010.

FUNDNET

THE MARK CONSISTS OF STANDARD CHARACTERS WITHOUT CLAIM TO ANY PARTICULAR FONT, STYLE, SIZE, OR COLOR.

OWNER OF U.S. REG. NO. 1,613,190.

CLASS 36—INSURANCE AND FINANCIAL

FOR PROVIDING AN INTERNET WEBSITE CONTAINING INFORMATION AND ADVICE ON A VARIETY OF TOPICS IN THE FIELDS OF TITLE INSURANCE UNDERWRITING SERVICES, REAL ESTATE TRANSACTION SERVICES, AND REAL ESTATE CLOSING SERVICES (U.S. CLS. 100, 101 AND 102).

FIRST USE 4-0-2003; IN COMMERCE 4-0-2003.

CLASS 45—PERSONAL AND LEGAL SERVICES

FOR PROVIDING AN INTERNET WEBSITE CONTAINING INFORMATION AND ADVICE ON A VARIETY OF TOPICS IN THE FIELD OF REAL ESTATE LAW (U.S. CLS. 100 AND 101).

FIRST USE 4-0-2003; IN COMMERCE 4-0-2003.
MICHAEL ENGEL, EXAMINING ATTORNEY

SN 85-142,426. TRUVIEW RESEARCH, LLC, AUSTIN, TX. FILED 9-30-2010.

TruView Research

THE MARK CONSISTS OF STANDARD CHARACTERS WITHOUT CLAIM TO ANY PARTICULAR FONT, STYLE, SIZE, OR COLOR.

NO CLAIM IS MADE TO THE EXCLUSIVE RIGHT TO USE "RESEARCH", APART FROM THE MARK AS SHOWN.

CLASS 35—ADVERTISING AND BUSINESS

FOR BUSINESS SERVICES, NAMELY, OPERATING TELEPRESENCE ENVIRONMENTS OF OTHERS, NAMELY, MANAGING TELEPRESENCE ENVIRONMENTS FOR OTHERS; BUSINESS RESEARCH USING FOCUS GROUPS, NAMELY, PROVIDING FOCUS GROUP SUPPORT SERVICES TO MARKET RESEARCH COMPANIES, INCLUDING FOOD/BEVERAGES TO FOCUS GROUP PARTICIPANTS AND MAKING INCENTIVE PAYMENTS (U.S. CLS. 100, 101 AND 102).

FIRST USE 10-13-2010; IN COMMERCE 10-13-2010.

CLASS 38—COMMUNICATION

FOR PROVIDING VIDEO TELECONFERENCING FACILITIES TO MARKET RESEARCH COMPANIES; PROVIDING TELEPRESENCE CONFERENCING SERVICES (U.S. CLS. 100, 101 AND 104).

FIRST USE 10-13-2010; IN COMMERCE 10-13-2010.
BENJAMIN OKEKE, EXAMINING ATTORNEY

ANTEA

THE MARK CONSISTS OF STANDARD CHARACTERS WITHOUT CLAIM TO ANY PARTICULAR FONT, STYLE, SIZE, OR COLOR.

THE WORDING "ANTEA" HAS NO MEANING IN A FOREIGN LANGUAGE.

CLASS 35—ADVERTISING AND BUSINESS

FOR ADVERTISING AND BUSINESS MANAGEMENT CONSULTING; COMMERCIAL BUSINESS MANAGEMENT; BUSINESS ADMINISTRATION AND OFFICE FUNCTIONS; MARKET RESEARCH; MARKET ANALYSIS; BUSINESS CONSULTING IN THE FIELD OF ENVIRONMENTAL MANAGEMENT, NAMELY, ADVISING BUSINESSES ON ISSUES OF ENVIRONMENTAL IMPACT, CONSERVATION, PRESERVATION AND PROTECTION, AND ECONOMIC ANALYSIS FOR BUSINESS PURPOSES (U.S. CLS. 100, 101 AND 102).

CLASS 40—MATERIAL TREATMENT

FOR ENVIRONMENTAL REMEDIATION SERVICES, NAMELY, SOIL, WASTE AND/OR WATER TREATMENT SERVICES; HAZARDOUS WASTE MANAGEMENT; TREATMENT OF WASTE MATERIALS IN SOLID AND LIQUID FORMS; TREATMENT OF SOIL, SAND AND MATERIALS RESEMBLING SOIL; TREATMENT OF MATERIALS, NAMELY, EFFECTING SOIL INJECTIONS IN ORDER TO MAKE THE SOIL WATER RESISTANT OR TO HARDEN THE SOIL CONSTRUCTIVELY; ENVIRONMENTAL REMEDIATION SERVICES BY AN INJECTION COMPANY SPECIALIZED IN SOIL INJECTION TECHNIQUES, NAMELY, HORIZONTAL SOIL INJECTIONS, CONSTRUCTIVE SOIL INJECTIONS, GROUTED AND DAMMING INJECTIONS, INJECTIONS OF PROPERTY WITH DAMP LEAKAGES, BELOW GROUND LEVEL; TREATMENT OF MATERIALS FOR THE PURPOSE OF SOIL SANITATION AND SOIL DECONTAMINATION; ENVIRONMENTAL REMEDIATION CONSULTING SERVICES IN THE FIELD OF SOIL, AIR, WASTE AND WATER TREATMENT; SERVICES IN THE FIELD OF PROCESSING AND TREATMENT OF STEEL; PROCESSING, TREATMENT AND RECYCLING OF MINERAL AND ORGANIC SUBSTANCES, OF MATERIALS AND WASTE MATERIALS INTO SOLID OR LIQUID FERTILIZERS AND MIXTURES; OVERSIGHT MANAGEMENT OF HAZARDOUS AND NON-HAZARDOUS WASTES (U.S. CLS. 100, 103 AND 106).

CLASS 41—EDUCATION AND ENTERTAINMENT

FOR DEVELOPMENT OF HEALTH AND SAFETY TRAINING PROGRAMS FOR OTHERS (U.S. CLS. 100, 101 AND 107).

CLASS 42—SCIENTIFIC AND COMPUTER SERVICES

FOR CONSULTING SERVICES IN THE FIELD OF ENVIRONMENTAL ASSESSMENT AND PLANNING; ENGINEERING AND SURVEYOR SERVICES FOR BUILDING AND PROPERTY CONDITION ASSESSMENT; COMPUTER PROGRAMMING FOR ELECTRONIC DATA PROCESSING; DRAWING UP EXPERT REPORTS BY ENGINEERS AND LABORATORY TECHNICIANS; TECHNICAL CONSULTATION IN THE FIELD OF ENVIRONMENTAL ENGINEERING; SOIL ANALYSIS; PHOTOGRAMMETRY; PHOTOGRAMMETRICAL MAP PRODUCTION; CONDUCTING AERIAL SURVEYS; PROVIDING INFORMATION IN THE FIELD OF GEOGRAPHY, NAMELY, IDENTIFICATION, ANALYSIS,

AND INTERPRETATION OF THE DISTRIBUTION AND ARRANGEMENT OF LANDFORMS AND OTHER FEATURES OF THE EARTH'S SURFACE; SERVICES OF CHEMISTS, ENGINEERS, GEOGRAPHERS, NAMELY, MAPPING AND CARTOGRAPHY, ARCHITECTS AND LAND SURVEYORS; CONSULTING SERVICES RELATING TO HAZARDOUS MATERIALS MANAGEMENT; EVALUATION AND TESTING OF REAL ESTATE FOR THE PRESENCE OF HAZARDOUS MATERIAL; EVALUATING AND TESTING THE ENVIRONMENTAL QUALITIES AND IMPACT OF CONSUMER PRODUCTS FOR OTHERS; CONSULTING IN THE FIELD OF FACILITY WATER STEWARDSHIP, WATER MANAGEMENT AND IMPLEMENTATION OF WATER CONSERVATION PRACTICES; CONSULTING ON SOURCE WATER PROTECTION PROGRAMS; THIRD PARTY CERTIFICATION AUDITS, NAMELY, TESTING, ANALYSIS AND EVALUATION OF THIRD PARTY SERVICES FOR THE PURPOSE OF CERTIFICATION; ENVIRONMENTAL CONSULTING SERVICES, NAMELY, TECHNICAL CONSULTATION IN THE FIELD OF ENVIRONMENTAL ENGINEERING; ENVIRONMENTAL EVALUATION AND DUE DILIGENCE REVIEW FOR THE PRESENCE OF HAZARDOUS MATERIAL PRIOR TO PURCHASE AND SALE OF REAL ESTATE; DESIGN OF PETROLEUM HANDLING FACILITIES, AQUIFER RESTORATION SYSTEMS AND MINE DEWATERING SYSTEMS; DRAWING UP TECHNICAL EXPERT REPORTS IN THE FIELD OF SOIL SANITATION AND TREATMENT (U.S. CLS. 100 AND 101).

CLASS 45—PERSONAL AND LEGAL SERVICES

FOR LOCAL REGIONAL AND GLOBAL REGULATORY COMPLIANCE CONSULTING IN THE FIELD OF ENVIRONMENTAL, HEALTH AND SAFETY; CONDUCTING ENVIRONMENTAL, HEALTH AND SAFETY COMPLIANCE AUDITS; AUDITING OF OCCUPATIONAL HEALTH AND SAFETY PROGRAMS; TECHNICAL CONSULTATION IN THE FIELD OF OCCUPATIONAL HEALTH AND SAFETY; ENVIRONMENTAL REGULATION COMPLIANCE CONSULTING, NAMELY, REVIEWING STANDARDS AND PRACTICES TO ASSURE COMPLIANCE WITH ENVIRONMENTAL AND OSHA LAWS AND REGULATIONS; PERMITTING, NAMELY, OBTAINING ENVIRONMENTAL, DESIGN, ZONING AND OTHER GOVERNMENTAL PERMITS FOR DEVELOPMENT PROJECTS (U.S. CLS. 100 AND 101).

JAMES A. RAUEN, EXAMINING ATTORNEY

SN 85-143,372. XI, PATTY PING, DBA ORIGIN NUTRITION, INC., CORONA, CA. FILED 10-1-2010.

Sarah Tom

THE MARK CONSISTS OF STANDARD CHARACTERS WITHOUT CLAIM TO ANY PARTICULAR FONT, STYLE, SIZE, OR COLOR.

THE NAME IN THE MARK "SARAH TOM" DOES NOT IDENTIFY A LIVING INDIVIDUAL.

CLASS 18—LEATHER GOODS

FOR ALL-PURPOSE CARRYING BAGS; CARRY-ALL BAGS; DOG APPAREL; DOG CLOTHING; DOG COLLARS; NECKWEAR FOR DOGS; PET ACCESSORIES, NAMELY, SPECIALLY DESIGNED CANVAS, VINYL OR LEATHER BAGS ATTACHED TO ANIMAL LEASHES FOR HOLDING SMALL ITEMS SUCH AS KEYS, CREDIT CARDS, MONEY OR DISPOSABLE BAGS FOR DISPOSING OF PET WASTE (U.S. CLS. 1, 2, 3, 22 AND 41).

FIRST USE 6-1-2010; IN COMMERCE 9-1-2010.

CLASS 28—TOYS AND SPORTING GOODS

FOR CAT TOYS; DOG TOYS; PET TOYS; PET TOYS CONTAINING CATNIP; PLUSH TOYS; SQUEEZE TOYS; STUFFED TOY ANIMALS; STUFFED TOYS; TOY ANIMALS (U.S. CLS. 22, 23, 38 AND 50).

FIRST USE 6-1-2010; IN COMMERCE 9-1-2010.

JULIE GUTTADAURO, EXAMINING ATTORNEY

SN 85-143,531. MAD DOGG ATHLETICS, INC., VENICE, CA. FILED 10-1-2010.

SPINTECH

THE MARK CONSISTS OF STANDARD CHARACTERS WITHOUT CLAIM TO ANY PARTICULAR FONT, STYLE, SIZE, OR COLOR.

CLASS 3—COSMETICS AND CLEANING PREPARATIONS

FOR CLEANING PREPARATIONS FOR EXERCISE EQUIPMENT AND BICYCLES (U.S. CLS. 1, 4, 6, 50, 51 AND 52).

FIRST USE 2-1-2000; IN COMMERCE 2-1-2000.

CLASS 4—LUBRICANTS AND FUELS

FOR LUBRICANTS FOR EXERCISE EQUIPMENT AND BICYCLES (U.S. CLS. 1, 6 AND 15).

FIRST USE 2-1-2000; IN COMMERCE 2-1-2000.

ANDREA BUTLER, EXAMINING ATTORNEY

SN 85-143,563. MARLIN DARLIN OUTFITTERS, INC., PALM BEACH GARDENS, FL. FILED 10-1-2010.

MARLIN DARLIN OUTFITTERS

THE MARK CONSISTS OF STANDARD CHARACTERS WITHOUT CLAIM TO ANY PARTICULAR FONT, STYLE, SIZE, OR COLOR.

NO CLAIM IS MADE TO THE EXCLUSIVE RIGHT TO USE "OUTFITTERS", APART FROM THE MARK AS SHOWN.

CLASS 25—CLOTHING

FOR CLOTHING, NAMELY, PANTS, SHIRTS, BLOUSES, GLOVES, JEANS, OVERALLS, T-SHIRTS, LEGGINGS, UNDERWEAR, SWEATERS, JACKETS, SWEAT SHIRTS, SWEAT PANTS, FOUL WEATHER GEAR, BATHING SUITS, FOOTGEAR, NAMELY, FOOTWEAR, HEADGEAR, NAMELY, HATS AND CAPS, AND BELTS (U.S. CLS. 22 AND 39).

CLASS 35—ADVERTISING AND BUSINESS

FOR ON-LINE WHOLESALE AND RETAIL STORE SERVICES FEATURING CLOTHING, NAMELY, PANTS, SHIRTS, BLOUSES, GLOVES, JEANS, OVERALLS, T-SHIRTS, LEGGINGS, UNDERWEAR, SWEATERS, JACKETS, SWEAT SHIRTS, SWEAT PANTS, FOUL WEATHER GEAR, BATHING SUITS, FOOTGEAR, NAMELY, FOOTWEAR, HEADGEAR, NAMELY, HATS AND CAPS, AND BELTS (U.S. CLS. 100, 101 AND 102).
ERIN FALK, EXAMINING ATTORNEY

SN 85-143,713. V&V SUPREMO FOODS, INC., CHICAGO, IL. FILED 10-2-2010.

FIESTA MEXICANA

THE MARK CONSISTS OF STANDARD CHARACTERS WITHOUT CLAIM TO ANY PARTICULAR FONT, STYLE, SIZE, OR COLOR.

NO CLAIM IS MADE TO THE EXCLUSIVE RIGHT TO USE "MEXICANA", APART FROM THE MARK AS SHOWN. THE ENGLISH TRANSLATION OF "FIESTA MEXICANA" IN THE MARK IS "MEXICAN PARTY".

CLASS 29—MEATS AND PROCESSED FOODS

FOR CHEESE, SOUR CREAM, MEAT, PROCESSED BEANS AND REFRIED BEANS (U.S. CL. 46).

CLASS 30—STAPLE FOODS

FOR SOPES AND DESSERTS, NAMELY, FLAN, SWEETENED GELATINS, AND RICE PUDDING (U.S. CL. 46).
ADA HAN, EXAMINING ATTORNEY

SN 85-143,736. NORTHWESTERN CORPORATION, SIOUX FALLS, SD. FILED 10-2-2010.



OWNER OF U.S. REG. NOS. 2,513,688 AND 3,405,043.
NO CLAIM IS MADE TO THE EXCLUSIVE RIGHT TO USE "EFFICIENCY", APART FROM THE MARK AS SHOWN.
THE MARK CONSISTS OF THE STYLIZED LETTER AND SYMBOL "E+" WITH AN OVAL SWOOSH DESIGN IN THE BACKGROUND AND THE WORDING "EFFICIENCY PLUS".

CLASS 35—ADVERTISING AND BUSINESS

FOR PROMOTING PUBLIC AWARENESS OF ENERGY EFFICIENCY (U.S. CLS. 100, 101 AND 102).
FIRST USE 4-1-2010; IN COMMERCE 4-1-2010.

CLASS 39—TRANSPORTATION AND STORAGE

FOR PUBLIC UTILITY SERVICES (U.S. CLS. 100 AND 105).
FIRST USE 4-1-2010; IN COMMERCE 4-1-2010.
JACLYN KIDWELL WALKER, EXAMINING ATTORNEY

SN 85-143,837. HEALTH COMMUNICATIONS, INC., ARLINGTON, VA. FILED 10-3-2010.



THE MARK CONSISTS OF THE STYLIZED LETTERS "HC" CASTING A SHADOW IN THE FORM OF A TRIANGLE IN THE FOREGROUND.

CLASS 9—ELECTRICAL AND SCIENTIFIC APPARATUS

FOR PRERECORDED DOWNLOADABLE AUDIO, PHOTOGRAPHIC AND VIDEO RECORDINGS, AUDIO-TAPES, VIDEOTAPES, CDS, DVDS FEATURING CONTENT RELATED TO RESPONSIBLE SERVICE, SALE, AND CONSUMPTION OF ALCOHOL, BEVERAGES AND FOOD AND OPERATIONS OF FOOD AND BEVERAGE SERVICE ESTABLISHMENTS; AUDIO-VIDEO PHOTOGRAPH SLIDES; ELECTRONIC PUBLICATIONS FEATURING EDUCATIONAL, INSTRUCTIONAL, TRAINING, DEMONSTRATIVE AND TESTING CONTENT RELATED TO RESPONSIBLE SERVICE, SALE, AND CONSUMPTION OF ALCOHOL, BEVERAGES AND FOOD AND OPERATIONS OF FOOD AND BEVERAGE SERVICE ESTABLISHMENTS AND ELECTRONIC DOWNLOADABLE PUBLICATIONS OF EDUCATIONAL, INSTRUCTIONAL, TRAINING, DEMONSTRATIVE AND TESTING CONTENT RELATED TO RESPONSIBLE SERVICE, SALE, AND CONSUMPTION OF ALCOHOL, BEVERAGES AND FOOD AND OPERATIONS OF FOOD AND BEVERAGE SERVICE ESTABLISHMENTS; SOFTWARE FEATURING EDUCATION, INSTRUCTION, TRAINING, DEMONSTRATION AND TESTING CONTENT RELATED TO RESPONSIBLE SERVICE, SALE, AND CONSUMPTION OF ALCOHOL, BEVERAGES AND FOOD AND OPERATIONS OF FOOD AND BEVERAGE SERVICE ESTABLISHMENTS; ELECTRONIC PUBLICATIONS OF AUDIO, PHOTOGRAPHIC AND VIDEO RECORDINGS AND AUDIO-VIDEO PHOTOGRAPH SLIDES; SOFTWARE TO ENABLE OR FACILITATE THE UPLOADING, DOWNLOADING, STREAMING, POSTING, DISPLAYING, BLOGGING, LINKING, SHARING OR OTHERWISE PROVIDING ELECTRONIC MEDIA OR INFORMATION OVER COMMUNICATION NETWORKS; SOFTWARE PROVIDING INFORMATION FROM SEARCHABLE INDEXES AND DATABASES OF INFORMATION, INCLUDING TEXT, ELECTRONIC DOCUMENTS, DATABASES, GRAPHICS AND AUDIO VISUAL INFORMATION (U.S. CLS. 21, 23, 26, 36 AND 38).

FIRST USE 3-1-2002; IN COMMERCE 3-1-2002.

CLASS 16—PAPER GOODS AND PRINTED MATTER

FOR PRINTED MATTER, NAMELY, INSTRUCTIONAL TEACHING AND TRAINING MANUALS, NEWSLETTERS AND PERIODICALS, REFERENCE BOOKS, WORKBOOKS, TEXTBOOKS IN THE FIELD OF RESPONSIBLE SERVICE, SALE, AND CONSUMPTION OF ALCOHOL, BEVERAGES AND FOOD AND OPERATIONS OF FOOD AND BEVERAGE SERVICE ESTABLISHMENTS, CATALOGS, MANUSCRIPTS, CLASSROOM AND INDEPENDENT STUDY GUIDES, PAMPHLETS, LEAFLETS, DIRECTORIES, JOURNALS, CALENDARS, BROCHURES, CHARTS, FACT SHEETS, PRACTICE SHEETS, FOLIOS, NOTEBOOKS, APPOINTMENT BOOKS, APPOINTMENT CARDS, NOTE CARDS, POST CARDS, FOLDERS, STATIONARY, NOTE PADS, PENS, PENCILS, BINDERS, LOOSE-LEAF BINDERS, BUMPER STICKERS, DECALS, STICKERS (U.S. CLS. 2, 5, 22, 23, 29, 37, 38 AND 50).

FIRST USE 3-1-2002; IN COMMERCE 3-1-2002.

CLASS 35—ADVERTISING AND BUSINESS

FOR BUSINESS CONSULTATION SERVICES ON THE SUBJECTS OF BUSINESS REENGINEERING, E-COMMERCE AND ON-LINE COMMERCE; PROVIDING BUSINESS INFORMATION OVER GLOBAL, LOCAL AND INTERNAL COMPUTER NETWORKS ON THE SUBJECTS OF BUSINESS PLANNING, BUSINESS REENGINEERING, ON-LINE COMMERCE AND E-COMMERCE; PROVIDING BUSINESS INFORMATION VIA THE INTERNET ON THE SUBJECTS OF BUSINESS PLANNING, BUSINESS REENGINEERING, ON-LINE COMMERCE AND E-COMMERCE (U.S. CLS. 100, 101 AND 102).

FIRST USE 3-1-2002; IN COMMERCE 3-1-2002.

CLASS 41—EDUCATION AND ENTERTAINMENT

FOR PROVIDING EDUCATIONAL SERVICES, NAMELY, CONDUCTING SEMINARS, PROGRAMS AND WORKSHOPS IN THE FIELD OF RESPONSIBLE SERVICE, SALE, AND CONSUMPTION OF ALCOHOL, BEVERAGES AND FOOD AND OPERATIONS OF FOOD AND BEVERAGE SERVICE ESTABLISHMENTS; EDUCATIONAL SERVICES, NAMELY, THE TRAINING OF OTHERS THROUGH COURSES, SEMINARS, PROGRAMS AND WORKSHOPS IN THE FIELD OF RESPONSIBLE SERVICE, SALE, AND CONSUMPTION OF ALCOHOL, BEVERAGES AND FOOD AND OPERATIONS OF FOOD AND BEVERAGE SERVICE ESTABLISHMENTS; EDUCATIONAL SERVICES, NAMELY, PROVIDING COURSES OF INSTRUCTION AT THE SECONDARY, POST-SECONDARY AND COLLEGE LEVEL IN THE FIELD OF RESPONSIBLE SERVICE, SALE, AND CONSUMPTION OF ALCOHOL, BEVERAGES AND FOOD AND OPERATIONS OF FOOD AND BEVERAGE SERVICE ESTABLISHMENTS (U.S. CLS. 100, 101 AND 107).

FIRST USE 3-1-2002; IN COMMERCE 3-1-2002.

CLASS 42—SCIENTIFIC AND COMPUTER SERVICES

FOR CONSULTING SERVICES IN THE FIELD OF DESIGN, SELECTION, IMPLEMENTATION AND USE OF COMPUTER SYSTEMS FOR OTHERS; COMPUTER CONSULTING SERVICES FOR PLANNING, DESIGN AND ANALYSIS OF INFORMATION PROCESSES, SYSTEMS AND BUSINESS REENGINEERING; COMPUTER CONSULTING SERVICES, NAMELY, ANALYSIS AND DESIGN OF COMPUTER SYSTEMS AND INFORMATION SYSTEMS FOR OTHERS; DESIGN FOR OTHERS OF SOFTWARE APPLICATIONS; PROVIDING DESIGN AND DEVELOPMENT FOR OTHERS' COMPUTER NETWORKS; INFORMATION TECHNOLOGY CONSULTATION SERVICES; COMPUTER CONSULTING SERVICES, NAMELY, CONSULTATION ON THE COMPUTER-RELATED ASPECTS OF E-COMMERCE AND INFORMATION TECHNOLOGY; COMPUTER SERVICES, NAMELY, HOSTING ONLINE WEB FACILITIES FOR OTHERS FOR ORGANIZING AND CONDUCTING ONLINE MEETINGS, GATHERINGS, AND INTERACTIVE DISCUSSIONS; COMPUTER SERVICES IN THE NAT-

URE OF CUSTOMIZED WEB PAGES FEATURING USER-DEFINED INFORMATION, PERSONAL PROFILES AND INFORMATION; COMPUTER SERVICES, NAMELY, CREATING AN ON-LINE COMMUNITY FOR REGISTERED USERS TO PARTICIPATE IN DISCUSSION, GET FEEDBACK FROM THEIR PEERS, FORM VIRTUAL COMMUNITIES, AND ENGAGE IN SOCIAL NETWORKING; PEER-TO-BROWSER PHOTO SHARING SERVICES, NAMELY, PROVIDING A WEBSITE FEATURING TECHNOLOGY ENABLING USERS TO UPLOAD, VIEW AND DOWNLOAD DIGITAL PHOTOS AND CONTENT; PROVIDING TEMPORARY USE OF NON-DOWNLOADABLE SOFTWARE APPLICATIONS FOR TRANSMISSION OF PHOTOGRAPHIC IMAGES, AUDIO AND VIDEO; ELECTRONIC PUBLISHING SERVICES, NAMELY, PUBLISHING OF WORKS OF OTHERS ONLINE FEATURING USER-CREATED TEXT, AUDIO, VIDEO, AND GRAPHICS; PROVIDING ONLINE JOURNALS AND WEB LOGS FEATURING USER-CREATED CONTENT; COMPUTER SERVICES, NAMELY, CREATING VIRTUAL COMMUNITIES FOR REGISTERED USERS TO ORGANIZE GROUPS AND EVENTS, PARTICIPATE IN DISCUSSIONS, AND ENGAGE IN SOCIAL, BUSINESS AND COMMUNITY NETWORKING; COMPUTER SERVICES, NAMELY, HOSTING ELECTRONIC FACILITIES FOR OTHERS FOR ORGANIZING AND CONDUCTING MEETINGS, EVENTS AND INTERACTIVE DISCUSSIONS VIA COMMUNICATION NETWORKS; APPLICATION SERVICE PROVIDER (ASP) SERVICES, NAMELY, HOSTING COMPUTER SOFTWARE APPLICATIONS OF OTHERS; APPLICATION SERVICE PROVIDER (ASP) FEATURING SOFTWARE TO ENABLE OR FACILITATE THE UPLOADING, DOWNLOADING, STREAMING, POSTING, DISPLAYING, BLOGGING, LINKING, SHARING OR OTHERWISE PROVIDING ELECTRONIC MEDIA OR INFORMATION OVER COMMUNICATION NETWORKS; PROVIDING AN ONLINE NETWORK SERVICE THAT ENABLES USERS TO TRANSFER PERSONAL IDENTITY DATA TO AND SHARE PERSONAL IDENTITY DATA WITH AND AMONG MULTIPLE WEBSITES; PROVIDING A WEB SITE FEATURING TECHNOLOGY THAT ENABLES ONLINE USERS TO CREATE PERSONAL PROFILES FEATURING SOCIAL NETWORKING INFORMATION AND TO TRANSFER AND SHARE SUCH INFORMATION AMONG MULTIPLE WEBSITES; PROVIDING INFORMATION IN THE FIELD OF RESPONSIBLE SERVICE, SALE, AND CONSUMPTION OF ALCOHOL, BEVERAGES AND FOOD AND OPERATIONS OF FOOD AND BEVERAGE SERVICE ESTABLISHMENTS FROM SEARCHABLE INDEXES AND DATABASES OF INFORMATION, INCLUDING TEXT, ELECTRONIC DOCUMENTS, DATABASES, GRAPHICS AND AUDIO VISUAL INFORMATION, ON COMPUTER AND COMMUNICATION NETWORKS; PROVIDING TEMPORARY USE OF NON-DOWNLOADABLE SOFTWARE APPLICATIONS FOR SOCIAL NETWORKING, CREATING A VIRTUAL COMMUNITY, AND TRANSMISSION OF AUDIO, VIDEO, PHOTOGRAPHIC IMAGES, TEXT, GRAPHICS AND DATA; COMPUTER SERVICES IN THE NATURE OF CUSTOMIZED WEB PAGES FEATURING USER-DEFINED OR SPECIFIED INFORMATION, PERSONAL PROFILES, AUDIO, VIDEO, PHOTOGRAPHIC IMAGES, TEXT, GRAPHICS AND DATA (U.S. CLS. 100 AND 101).

FIRST USE 3-1-2002; IN COMMERCE 3-1-2002.

GINA HAYES, EXAMINING ATTORNEY

SN 85-143,843. HEALTH COMMUNICATIONS, INC., ARLINGTON, VA. FILED 10-3-2010.

HCI

THE MARK CONSISTS OF STANDARD CHARACTERS WITHOUT CLAIM TO ANY PARTICULAR FONT, STYLE, SIZE, OR COLOR.

CLASS 9—ELECTRICAL AND SCIENTIFIC APPARATUS

FOR PRERECORDED DOWNLOADABLE AUDIO, PHOTOGRAPHIC AND VIDEO RECORDINGS, AUDIOTAPES, VIDEOTAPES, CDS, DVDS FEATURING CONTENT RELATED TO RESPONSIBLE SERVICE, SALE, AND CONSUMPTION OF ALCOHOL, BEVERAGES AND FOOD AND OPERATIONS OF FOOD AND BEVERAGE SERVICE ESTABLISHMENTS; AUDIO-VIDEO PHOTOGRAPH SLIDES; ELECTRONIC PUBLICATIONS FEATURING EDUCATIONAL, INSTRUCTIONAL, TRAINING, DEMONSTRATIVE AND TESTING CONTENT RELATED TO RESPONSIBLE SERVICE, SALE, AND CONSUMPTION OF ALCOHOL, BEVERAGES AND FOOD AND OPERATIONS OF FOOD AND BEVERAGE SERVICE ESTABLISHMENTS AND ELECTRONIC DOWNLOADABLE PUBLICATIONS OF EDUCATIONAL, INSTRUCTIONAL, TRAINING, DEMONSTRATIVE AND TESTING CONTENT RELATED TO RESPONSIBLE SERVICE, SALE, AND CONSUMPTION OF ALCOHOL, BEVERAGES AND FOOD AND OPERATIONS OF FOOD AND BEVERAGE SERVICE ESTABLISHMENTS; SOFTWARE FEATURING EDUCATION, INSTRUCTION, TRAINING, DEMONSTRATION AND TESTING CONTENT RELATED TO RESPONSIBLE SERVICE, SALE, AND CONSUMPTION OF ALCOHOL, BEVERAGES AND FOOD AND OPERATIONS OF FOOD AND BEVERAGE SERVICE ESTABLISHMENTS; ELECTRONIC PUBLICATIONS OF AUDIO, PHOTOGRAPHIC AND VIDEO RECORDINGS AND AUDIO-VIDEO PHOTOGRAPH SLIDES; SOFTWARE TO ENABLE OR FACILITATE THE UPLOADING, DOWNLOADING, STREAMING, POSTING, DISPLAYING, BLOGGING, LINKING, SHARING OR OTHERWISE PROVIDING ELECTRONIC MEDIA OR INFORMATION OVER COMMUNICATION NETWORKS; SOFTWARE PROVIDING INFORMATION FROM SEARCHABLE INDEXES AND DATABASES OF INFORMATION, INCLUDING TEXT, ELECTRONIC DOCUMENTS, DATABASES, GRAPHICS AND AUDIO VISUAL INFORMATION (U.S. CLS. 21, 23, 26, 36 AND 38).

FIRST USE 6-3-1997; IN COMMERCE 6-3-1997.

CLASS 16—PAPER GOODS AND PRINTED MATTER

FOR PRINTED MATTER, NAMELY, INSTRUCTIONAL TEACHING AND TRAINING MANUALS, NEWSLETTERS AND PERIODICALS, REFERENCE BOOKS, WORKBOOKS, TEXTBOOKS IN THE FIELD OF RESPONSIBLE SERVICE, SALE, AND CONSUMPTION OF ALCOHOL, BEVERAGES AND FOOD AND OPERATIONS OF FOOD AND BEVERAGE SERVICE ESTABLISHMENTS, CATALOGS, MANUSCRIPTS, CLASSROOM AND INDEPENDENT STUDY GUIDES, PAMPHLETS, LEAFLETS, DIRECTORIES, JOURNALS, CALENDARS, BROCHURES, CHARTS, FACT SHEETS, PRACTICE SHEETS, FOLIOS, NOTEBOOKS, APPOINTMENT BOOKS, APPOINTMENT CARDS, NOTE CARDS, POST CARDS, FOLDERS, STATIONARY, NOTE PADS, PENS, PENCILS, BINDERS, LOOSE-LEAF BINDERS, BUMPER STICKERS, DECALS, STICKERS (U.S. CLS. 2, 5, 22, 23, 29, 37, 38 AND 50).

FIRST USE 6-3-1997; IN COMMERCE 6-3-1997.

CLASS 35—ADVERTISING AND BUSINESS

FOR BUSINESS CONSULTATION SERVICES ON THE SUBJECTS OF BUSINESS REENGINEERING, E-COMMERCE AND ON-LINE COMMERCE; PROVIDING BUSINESS INFORMATION OVER GLOBAL, LOCAL AND INTERNAL COMPUTER NETWORKS ON THE SUBJECTS OF BUSINESS PLANNING, BUSINESS REENGINEERING, ON-LINE COMMERCE AND E-COMMERCE; PROVIDING BUSINESS INFORMATION VIA THE INTERNET ON THE SUBJECTS OF BUSINESS PLANNING, BUSINESS REENGINEERING, ON-LINE COMMERCE AND E-COMMERCE (U.S. CLS. 100, 101 AND 102).

FIRST USE 6-3-1997; IN COMMERCE 6-3-1997.

CLASS 41—EDUCATION AND ENTERTAINMENT

FOR PROVIDING EDUCATIONAL SERVICES, NAMELY, CONDUCTING SEMINARS, PROGRAMS AND WORKSHOPS IN THE FIELD OF RESPONSIBLE SERVICE, SALE, AND CONSUMPTION OF ALCOHOL, BEVERAGES AND FOOD AND OPERATIONS OF FOOD AND BEVERAGE SERVICE ESTABLISHMENTS; EDUCATIONAL SERVICES, NAMELY, THE TRAINING OF OTHERS THROUGH COURSES, SEMINARS, PROGRAMS AND WORKSHOPS IN THE FIELD OF RESPONSIBLE SERVICE, SALE, AND CONSUMPTION OF ALCOHOL, BEVERAGES AND FOOD AND OPERATIONS OF FOOD AND BEVERAGE SERVICE ESTABLISHMENTS; EDUCATIONAL SERVICES, NAMELY, PROVIDING COURSES OF INSTRUCTION AT THE SECONDARY, POST-SECONDARY AND COLLEGE LEVEL IN THE FIELD OF RESPONSIBLE SERVICE, SALE, AND CONSUMPTION OF ALCOHOL, BEVERAGES AND FOOD AND OPERATIONS OF FOOD AND BEVERAGE SERVICE ESTABLISHMENTS (U.S. CLS. 100, 101 AND 107).

FIRST USE 6-3-1997; IN COMMERCE 6-3-1997.

CLASS 42—SCIENTIFIC AND COMPUTER SERVICES

FOR CONSULTING SERVICES IN THE FIELD OF DESIGN, SELECTION, IMPLEMENTATION AND USE OF COMPUTER SYSTEMS FOR OTHERS; COMPUTER CONSULTING SERVICES FOR PLANNING, DESIGN AND ANALYSIS OF INFORMATION PROCESSES, SYSTEMS AND BUSINESS REENGINEERING; COMPUTER CONSULTING SERVICES, NAMELY, ANALYSIS AND DESIGN OF COMPUTER SYSTEMS AND INFORMATION SYSTEMS FOR OTHERS; DESIGN FOR OTHERS OF SOFTWARE APPLICATIONS; PROVIDING DESIGN AND DEVELOPMENT FOR OTHERS' COMPUTER NETWORKS; INFORMATION TECHNOLOGY CONSULTATION SERVICES; COMPUTER CONSULTING SERVICES, NAMELY, CONSULTATION ON THE COMPUTER-RELATED ASPECTS OF E-COMMERCE AND INFORMATION TECHNOLOGY; COMPUTER SERVICES, NAMELY, HOSTING ONLINE WEB FACILITIES FOR OTHERS FOR ORGANIZING AND CONDUCTING ONLINE MEETINGS, GATHERINGS, AND INTERACTIVE DISCUSSIONS; COMPUTER SERVICES IN THE NATURE OF CUSTOMIZED WEB PAGES FEATURING USER-DEFINED INFORMATION, PERSONAL PROFILES AND INFORMATION; COMPUTER SERVICES, NAMELY, CREATING AN ON-LINE COMMUNITY FOR REGISTERED USERS TO PARTICIPATE IN DISCUSSION, GET FEEDBACK FROM THEIR PEERS, FORM VIRTUAL COMMUNITIES, AND ENGAGE IN SOCIAL NETWORKING; PEER-TO-BROWSER PHOTO SHARING SERVICES, NAMELY, PROVIDING A WEBSITE FEATURING TECHNOLOGY ENABLING USERS TO UPLOAD, VIEW AND DOWNLOAD DIGITAL PHOTOS AND CONTENT; PROVIDING TEMPORARY USE OF NON-DOWNLOADABLE SOFTWARE APPLICATIONS FOR TRANSMISSION OF PHOTOGRAPHIC IMAGES, AUDIO AND VIDEO; ELECTRONIC PUBLISHING SERVICES, NAMELY, PUBLISHING OF WORKS OF OTHERS ONLINE FEATURING USER-CREATED TEXT, AUDIO, VIDEO, AND GRAPHICS; PROVIDING ONLINE JOURNALS AND WEB LOGS FEATURING USER-CREATED CONTENT; COMPUTER SERVICES, NAMELY, CREATING VIRTUAL COMMUNITIES FOR REGISTERED USERS TO ORGANIZE GROUPS AND EVENTS, PARTICIPATE IN DISCUSSIONS, AND ENGAGE IN SOCIAL, BUSINESS AND COMMUNITY NETWORKING; COMPUTER SERVICES, NAMELY, HOSTING ELECTRONIC FACILITIES FOR OTHERS FOR ORGANIZING AND CONDUCTING MEETINGS, EVENTS AND INTERACTIVE DISCUSSIONS VIA COMMUNICATION NETWORKS; APPLICATION SERVICE PROVIDER (ASP) SERVICES, NAMELY, HOSTING COMPUTER SOFTWARE APPLICATIONS OF OTHERS; APPLICATION SERVICE PROVIDER (ASP) FEATURING SOFTWARE TO ENABLE OR FACILITATE THE UPLOADING, DOWNLOADING, STREAMING, POSTING, DISPLAYING, BLOGGING, LINKING, SHARING OR OTHERWISE PROVIDING ELECTRONIC MEDIA OR INFORMATION OVER COMMUNICATION NETWORKS; PROVIDING AN ONLINE NETWORK SERVICE THAT ENABLES USERS TO TRANSFER PERSONAL IDENTITY DATA TO AND SHARE PERSONAL IDENTI-

FY DATA WITH AND AMONG MULTIPLE WEBSITES; PROVIDING A WEB SITE FEATURING TECHNOLOGY THAT ENABLES ONLINE USERS TO CREATE PERSONAL PROFILES FEATURING SOCIAL NETWORKING INFORMATION AND TO TRANSFER AND SHARE SUCH INFORMATION AMONG MULTIPLE WEBSITES; PROVIDING INFORMATION IN THE FIELD OF RESPONSIBLE SERVICE, SALE, AND CONSUMPTION OF ALCOHOL, BEVERAGES AND FOOD AND OPERATIONS OF FOOD AND BEVERAGE SERVICE ESTABLISHMENTS FROM SEARCHABLE INDEXES AND DATABASES OF INFORMATION, INCLUDING TEXT, ELECTRONIC DOCUMENTS, DATABASES, GRAPHICS AND AUDIO VISUAL INFORMATION, ON COMPUTER AND COMMUNICATION NETWORKS; PROVIDING TEMPORARY USE OF NON-DOWNLOADABLE SOFTWARE APPLICATIONS FOR SOCIAL NETWORKING, CREATING A VIRTUAL COMMUNITY, AND TRANSMISSION OF AUDIO, VIDEO, PHOTOGRAPHIC IMAGES, TEXT, GRAPHICS AND DATA; COMPUTER SERVICES IN THE NATURE OF CUSTOMIZED WEB PAGES FEATURING USER-DEFINED OR SPECIFIED INFORMATION, PERSONAL PROFILES, AUDIO, VIDEO, PHOTOGRAPHIC IMAGES, TEXT, GRAPHICS AND DATA (U.S. CLS. 100 AND 101).

FIRST USE 6-3-1997; IN COMMERCE 6-3-1997.
GINA HAYES, EXAMINING ATTORNEY

SN 85-144,180. RESNICOW, JOEL, SAN FRANCISCO, CA.
FILED 10-4-2010.

REXLY

THE MARK CONSISTS OF STANDARD CHARACTERS WITHOUT CLAIM TO ANY PARTICULAR FONT, STYLE, SIZE, OR COLOR.

CLASS 35—ADVERTISING AND BUSINESS

FOR PROVIDING A WEBSITE FOR USERS WITH SPECIFIC INFORMED RECOMMENDATIONS OF SPECIFIC CONSUMER PRODUCTS AND SERVICES, SUCH AS MUSIC, BOOKS AND FILMS, VALIDATED BY THE USERS' PREFERENCES AND SOCIAL NETWORK; PROVIDING CONSUMER INFORMATION SERVICES AND MAKING REFERRALS IN THE FIELD OF ENTERTAINMENT SERVICES FOR PRODUCTS, SERVICES, EVENTS, ACTIVITIES, FACILITIES AND LOCATIONS; ADVERTISING SERVICES, NAMELY, PROMOTING THE GOODS AND SERVICES OF OTHERS (U.S. CLS. 100, 101 AND 102).

CLASS 45—PERSONAL AND LEGAL SERVICES

FOR INTERNET BASED SOCIAL NETWORKING SERVICES (U.S. CLS. 100 AND 101).
DOUGLAS LEE, EXAMINING ATTORNEY

SN 85-144,232. WORLDS APART LTD, CORNWALL, UNITED KINGDOM, FILED 10-4-2010.

GO GLOW

THE MARK CONSISTS OF STANDARD CHARACTERS WITHOUT CLAIM TO ANY PARTICULAR FONT, STYLE, SIZE, OR COLOR.

OWNER OF ERPN CMNTY TM OFC REG. NO. 4500229, DATED 6-13-2006, EXPIRES 7-18-2015.

NO CLAIM IS MADE TO THE EXCLUSIVE RIGHT TO USE "GLOW", APART FROM THE MARK AS SHOWN.

CLASS 11—ENVIRONMENTAL CONTROL APPARATUS

FOR LIGHTING APPARATUS, NAMELY, COMBINATION RECHARGEABLE FLASHLIGHT AND NIGHT LIGHT; LIGHTING APPARATUS, NAMELY, COMBINATION RECHARGEABLE FLASHLIGHT AND NIGHT LIGHT WITH IMAGE PROJECTOR AND CUSTOMIZABLE STICKERS; LIGHTING APPARATUS, NAMELY, COMBINATION NIGHT LIGHT AND HEAD CUSHION; FLASHLIGHTS; ELECTRIC TORCHES FOR LIGHTING; ELECTRIC NIGHT LIGHTS; PARTS AND FITTINGS FOR THE AFOREMENTIONED GOODS (U.S. CLS. 13, 21, 23, 31 AND 34).

CLASS 28—TOYS AND SPORTING GOODS

FOR GAMES, TOYS AND PLAYTHINGS, NAMELY, PLUSH TOYS WITH LIGHTS (U.S. CLS. 22, 23, 38 AND 50).

KATHRYN COWARD, EXAMINING ATTORNEY

SN 85-144,573. TAITTINGER COMPAGNIE COMMERCIALE ET VITICOLE CHAMPENOISE, REIMS, FRANCE, FILED 10-4-2010.

TAITTINGER COLLECTION

THE MARK CONSISTS OF STANDARD CHARACTERS WITHOUT CLAIM TO ANY PARTICULAR FONT, STYLE, SIZE, OR COLOR.

NO CLAIM IS MADE TO THE EXCLUSIVE RIGHT TO USE "COLLECTION", APART FROM THE MARK AS SHOWN.

CLASS 16—PAPER GOODS AND PRINTED MATTER

FOR ART BOOKS, POSTCARDS, PAPER LABELS, PHOTOGRAPHS, PAINTINGS AND PICTURES, FRAMED OR UNFRAMED (U.S. CLS. 2, 5, 22, 23, 29, 37, 38 AND 50).

CLASS 21—HOUSEWARES AND GLASS

FOR DECORATED BOTTLES SOLD EMPTY, INCLUDING SCREEN-PRINTED BOTTLES (U.S. CLS. 2, 13, 23, 29, 30, 33, 40 AND 50).

CLASS 41—EDUCATION AND ENTERTAINMENT

FOR ORGANIZATION OF EXHIBITIONS FOR CULTURAL OR EDUCATIONAL PURPOSES (U.S. CLS. 100, 101 AND 107).

LIEF MARTIN, EXAMINING ATTORNEY

SN 85-144,587. VALUEOPTIONS, INC., NORFOLK, VA. FILED 10-4-2010.

ValueOptions Health Alert

THE MARK CONSISTS OF STANDARD CHARACTERS WITHOUT CLAIM TO ANY PARTICULAR FONT, STYLE, SIZE, OR COLOR.

OWNER OF U.S. REG. NOS. 3,089,322, 3,623,914 AND OTHERS.

NO CLAIM IS MADE TO THE EXCLUSIVE RIGHT TO USE "HEALTH ALERT", APART FROM THE MARK AS SHOWN.

CLASS 35—ADVERTISING AND BUSINESS

FOR COLLECTION OF INFORMATION INTO COMPUTER DATABASES IN THE FIELD OF PERSONAL HEALTH AND MEDICAL INFORMATION (U.S. CLS. 100, 101 AND 102).

CLASS 38—COMMUNICATION

FOR TELECOMMUNICATION SERVICES, NAMELY, PROVIDING ELECTRONIC MESSAGE NOTIFICATION ALERTS IN THE FIELD OF PERSONAL HEALTH AND MEDICAL INFORMATION (U.S. CLS. 100, 101 AND 104).

CLASS 39—TRANSPORTATION AND STORAGE

FOR ELECTRONIC STORAGE OF PERSONAL HEALTH AND MEDICAL INFORMATION (U.S. CLS. 100 AND 105).

CLASS 44—MEDICAL, BEAUTY AND AGRICULTURAL SERVICES

FOR PROVIDING MEDICAL INFORMATION REGARDING MEDICAL APPOINTMENT TIMES, MEDICATION ADMINISTRATION TIMES AND MEDICATION REFILL TIMES VIA E-MAIL NOTIFICATION ALERTS (U.S. CLS. 100 AND 101).

DANIEL CAPSHAW, EXAMINING ATTORNEY

SN 85-144,970. BATS GLOBAL MARKETS, INC., LENEXA, KS. FILED 10-5-2010.

BATS Exchange

THE MARK CONSISTS OF STANDARD CHARACTERS WITHOUT CLAIM TO ANY PARTICULAR FONT, STYLE, SIZE, OR COLOR.

OWNER OF U.S. REG. NOS. 3,288,792, 3,818,024 AND OTHERS.

NO CLAIM IS MADE TO THE EXCLUSIVE RIGHT TO USE "EXCHANGE", APART FROM THE MARK AS SHOWN.

CLASS 35—ADVERTISING AND BUSINESS

FOR COMPILING FINANCIAL, SECURITIES, STOCK EXCHANGE, TRADE AND QUOTE, INDEX VALUE AND OTHER FINANCIAL MARKET INFORMATION FOR BUSINESS PURPOSES; PROVIDING FINANCIAL INDICES OF SELECT SECURITIES TO ENABLE CONSUMERS TO EVALUATE INVESTMENTS AND MARKET TRENDS IN THE SECURITIES MARKET (U.S. CLS. 100, 101 AND 102).

FIRST USE 11-1-2007; IN COMMERCE 10-1-2008.

CLASS 36—INSURANCE AND FINANCIAL

FOR FINANCIAL ADMINISTRATION OF STOCK EXCHANGE TRADING OF SHARES AND OTHER FINANCIAL SECURITIES IN FINANCIAL MARKETS; FINANCIAL SECURITIES EXCHANGE SERVICES; ORGANIZATION OF ONLINE STOCK EXCHANGES FOR THE BENEFIT OF THE TRADE OF STOCKS AND OTHER FINANCIAL SECURITIES; PROVIDING AN ON-LINE COMPUTER DATABASE IN THE FIELD OF STOCK/SECURITIES MARKET INFORMATION; SECURITIES TRADE EXECUTION SERVICES; SECURITIES TRADING SERVICES FOR OTHERS VIA THE INTERNET AND THE GLOBAL INFORMATION NETWORK (U.S. CLS. 100, 101 AND 102).

FIRST USE 11-1-2007; IN COMMERCE 10-1-2008.

CLASS 38—COMMUNICATION

FOR ELECTRONIC TRANSMISSION FOR OTHERS OF SECURITIES AND FINANCIAL INFORMATION VIA COMPUTER LINKING SERVICES, NAMELY, COMMUNICATING AND ROUTING TRADE INFORMATION INVOLVING ORDERS, ENTRY AND EXECUTION SERVICES, TO OTHERS VIA A GLOBAL COMPUTER NETWORK (U.S. CLS. 100, 101 AND 104).

FIRST USE 11-1-2007; IN COMMERCE 10-1-2008.

JULIE GUTTADAURO, EXAMINING ATTORNEY

SN 85-145,209. CRAZEWORTHY INC, WOODINVILLE, WA. FILED 10-5-2010.

NenlūTea

THE MARK CONSISTS OF STYLIZED LETTERS "NENLŪTEA".

THE ENGLISH TRANSLATION OF "NENLŪ" IN THE MARK IS FRESH GREEN.

CLASS 30—STAPLE FOODS

FOR COFFEE AND TEA; TEA-BASED BEVERAGES; ICED TEA; COFFEE BASED BEVERAGES; ESPRESSO; ESPRESSO-BASED BEVERAGES; CHOCOLATE AND VANILLA POWDER MIX FOR USE IN MAKING CHOCOLATE-BASED BEVERAGES AND VANILLA-BASED BEVERAGES; FLAVORING SYRUP; BAKERY GOODS, NAMELY, MUFFINS, SCONES, BISCUITS, COOKIES, PASTRIES AND BREADS; SANDWICHES (U.S. CL. 46).

FIRST USE 7-14-2008; IN COMMERCE 7-14-2008.

CLASS 32—LIGHT BEVERAGES

FOR NON-ALCOHOLIC FRUIT JUICE BEVERAGES; FRUIT DRINKS AND JUICES (U.S. CLS. 45, 46 AND 48).

FIRST USE 7-14-2008; IN COMMERCE 7-14-2008.

B. PARADEWELAI, EXAMINING ATTORNEY

SN 85-145,264. WEIGEL STORES, INC., POWELL, TN. FILED 10-5-2010.

SN 85-145,448. BWF TEXTIL GMBH & CO. KG, OFFINGEN, FED REP GERMANY, FILED 10-5-2010.

TENNESSEE TRAVELER

THE MARK CONSISTS OF STANDARD CHARACTERS WITHOUT CLAIM TO ANY PARTICULAR FONT, STYLE, SIZE, OR COLOR.

NO CLAIM IS MADE TO THE EXCLUSIVE RIGHT TO USE "TENNESSEE", APART FROM THE MARK AS SHOWN.

CLASS 30—STAPLE FOODS

FOR COFFEE-BASED BEVERAGES AND FROZEN COFFEE-BASED BEVERAGES WITH MOCHA AND FRENCH VANILLA FLAVORING FOR SALE IN APPLICANT'S STORES IN REFILLABLE CONTAINERS (U.S. CL. 46).

FIRST USE 4-1-1993; IN COMMERCE 4-1-1993.

CLASS 32—LIGHT BEVERAGES

FOR SOFT DRINKS AND FROZEN FRUIT DRINKS FOR SALE IN APPLICANT'S STORES IN REFILLABLE CONTAINERS (U.S. CLS. 45, 46 AND 48).

FIRST USE 4-1-1993; IN COMMERCE 4-1-1993.
SUE LAWRENCE, EXAMINING ATTORNEY

SN 85-145,397. JEFFREY J. KRAFT, PRESCOTT, WI. FILED 10-5-2010.

KALAHARI KRITTERS

THE MARK CONSISTS OF STANDARD CHARACTERS WITHOUT CLAIM TO ANY PARTICULAR FONT, STYLE, SIZE, OR COLOR.

NO CLAIM IS MADE TO THE EXCLUSIVE RIGHT TO USE "KRITTERS", APART FROM THE MARK AS SHOWN.

CLASS 25—CLOTHING

FOR CLOTHES, NAMELY, SHIRTS, SHORTS, JACKETS, SHOES AND HATS (U.S. CLS. 22 AND 39).

CLASS 28—TOYS AND SPORTING GOODS

FOR STUFFED TOYS (U.S. CLS. 22, 23, 38 AND 50).
ELISSA GARBER KON, EXAMINING ATTORNEY

BWF ENVIROTEC

THE MARK CONSISTS OF STANDARD CHARACTERS WITHOUT CLAIM TO ANY PARTICULAR FONT, STYLE, SIZE, OR COLOR.

CLASS 7—MACHINERY

FOR MACHINE PARTS, NAMELY, INDUSTRIAL DUST COLLECTION BAGS, DUST COLLECTOR BAG CAGES, LIQUID FILTER CLOTHS, BELTS AND DUST COLLECTOR BAG CARTRIDGES; AND REPLACEMENT PARTS AND FITTINGS FOR THE FOREGOING GOODS (U.S. CLS. 13, 19, 21, 23, 31, 34 AND 35).

CLASS 41—EDUCATION AND ENTERTAINMENT

FOR EDUCATIONAL SERVICES, NAMELY, PROVIDING HEALTH AND SAFETY TRAINING IN THE INSTALLATION, OPERATION AND TROUBLESHOOTING OF INDUSTRIAL DUST COLLECTION BAGS (U.S. CLS. 100, 101 AND 107).

CLASS 42—SCIENTIFIC AND COMPUTER SERVICES

FOR INSPECTION OF INDUSTRIAL DUST COLLECTION BAGS AND MACHINERY USED IN CONNECTION THEREWITH (U.S. CLS. 100 AND 101).

GRETTA YAO, EXAMINING ATTORNEY

SN 85-145,478. FOOD & FUN B.V., BEARS, NETHERLANDS, FILED 10-5-2010.



OWNER OF BENELUX REG. NO. 896658, DATED 3-9-2011, EXPIRES 2-15-2021.

THE COLOR(S) ORANGE, BLACK, WHITE, RED, GREEN, BLUE, YELLOW AND PURPLE IS/ARE CLAIMED AS A FEATURE OF THE MARK.

THE MARK CONSISTS OF AN OVAL ORANGE FRAME, OUTLINED IN BLACK AND WHITE, FEATURING THE WORDS "FOOD & FUN" IN WHITE, WITH A CHEF'S HAT PLACED ON TOP AND ABOVE IT, CONTAINING CIRCLES/DOTS IN THE COLORS ORANGE, RED, GREEN, BLUE, YELLOW AND PURPLE.

CLASS 11—ENVIRONMENTAL CONTROL APPARATUS

FOR PORTABLE ELECTRIC APPARATUS FOR HEATING AND COOKING, NAMELY, PORTABLE ELECTRIC TABLE OVENS, ELECTRIC TABLE GRILLS, ELECTRIC PANCAKE MAKERS; ELECTRIC COOKING APPLIANCES, NAMELY, PIZZA OVENS, ELECTRIC HOT PLATES; CHARCOAL GRILLS; NON-ELECTRIC COOKING EQUIPMENT, NAMELY, NON-ELECTRIC FONDUE POTS WITH A HEAT SOURCE, AS WELL AS FONDUE SETS COMPRISED OF NON-ELECTRIC FONDUE POTS, BURNERS, FORKS, BOWLS AND CANDLES SOLD AS A UNIT (U.S. CLS. 13, 21, 23, 31 AND 34).

CLASS 21—HOUSEWARES AND GLASS

FOR NON-ELECTRIC COOKING EQUIPMENT, NAMELY, NON-ELECTRIC FONDUE POTS WITHOUT A HEAT SOURCE, AS WELL AS FONDUE SETS COMPRISED OF NON-ELECTRIC FONDUE POTS WITHOUT A HEAT SOURCE, FORKS AND BOWLS SOLD AS A UNIT; NON-ELECTRIC GRILLS, NAMELY, CAMPING GRILLS; COOKING UTENSILS, NAMELY, GRILLS (U.S. CLS. 2, 13, 23, 29, 30, 33, 40 AND 50).
JAMES GRIFFIN, EXAMINING ATTORNEY

SN 85-146,285. EFAMOL LIMITED, SURREY, UNITED KINGDOM, FILED 10-6-2010.

EFANATAL

THE MARK CONSISTS OF STANDARD CHARACTERS WITHOUT CLAIM TO ANY PARTICULAR FONT, STYLE, SIZE, OR COLOR.

OWNER OF ERPN CMNTY TM OFC REG. NO. 003939543, DATED 11-21-2005, EXPIRES 7-20-2014.

CLASS 5—PHARMACEUTICALS

FOR FOOD FOR BABIES; VITAMINS; DIETETIC FOODS ADAPTED FOR MEDICAL USE; VITAMIN SUPPLEMENTS AND FOOD SUPPLEMENTS (U.S. CLS. 6, 18, 44, 46, 51 AND 52).

CLASS 29—MEATS AND PROCESSED FOODS

FOR EDIBLE OILS AND FATS, ALL CONTAINING GAMMA-LINOLENIC ACID (U.S. CL. 46).
KELLY TRUSILO, EXAMINING ATTORNEY

SN 85-146,463. EDISONLEARNING, INC., NEW YORK, NY. FILED 10-6-2010.

eSchoolware

THE MARK CONSISTS OF STANDARD CHARACTERS WITHOUT CLAIM TO ANY PARTICULAR FONT, STYLE, SIZE, OR COLOR.

CLASS 35—ADVERTISING AND BUSINESS

FOR BUSINESS MANAGEMENT AND OPERATION OF TUTORING PROGRAMS FOR OTHERS FOR ELEMENTARY, MIDDLE AND HIGH SCHOOL STUDENTS (U.S. CLS. 100, 101 AND 102).

CLASS 41—EDUCATION AND ENTERTAINMENT

FOR EDUCATION SERVICES, NAMELY, PROVIDING SEMINARS AND CLASSES FOR PUBLIC PRESCHOOL, KINDERGARTEN, ELEMENTARY, MIDDLE AND HIGH SCHOOL STUDENTS; EDUCATION SERVICES, NAMELY, PROVIDING AND CONDUCTING TUTORING PROGRAMS FOR ELEMENTARY, MIDDLE AND HIGH SCHOOL STUDENTS (U.S. CLS. 100, 101 AND 107).
GINA FINK, EXAMINING ATTORNEY

SN 85-146,808. RUSSELL-NEWMAN, INC., DENTON, TX. FILED 10-6-2010.

CYPRESS GREEN

THE MARK CONSISTS OF STANDARD CHARACTERS WITHOUT CLAIM TO ANY PARTICULAR FONT, STYLE, SIZE, OR COLOR.

OWNER OF U.S. REG. NO. 1,957,109.
NO CLAIM IS MADE TO THE EXCLUSIVE RIGHT TO USE "GREEN", APART FROM THE MARK AS SHOWN.

CLASS 24—FABRICS

FOR BED LINENS, NAMELY, BED SHEETS, BED BLANKETS, PILLOWCASES, PILLOW SHAMS, BED SKIRTS, BED SPREADS, DUVET COVERS, COMFORTERS, AND MATTRESS PADS; BATH LINENS, NAMELY, BATH TOWELS, BATH SHEETS, HAND TOWELS, WASH CLOTHS, FACE CLOTHS, TOWEL WRAPS (U.S. CLS. 42 AND 50).

CLASS 25—CLOTHING

FOR ROBES; SLIPPERS (U.S. CLS. 22 AND 39).
ALYSSA STEEL, EXAMINING ATTORNEY

SN 85-146,813. RUSSELL-NEWMAN, INC., DENTON, TX. FILED 10-6-2010.

CYPRESS LUXE

THE MARK CONSISTS OF STANDARD CHARACTERS WITHOUT CLAIM TO ANY PARTICULAR FONT, STYLE, SIZE, OR COLOR.

OWNER OF U.S. REG. NO. 1,957,109.
NO CLAIM IS MADE TO THE EXCLUSIVE RIGHT TO USE "LUXE", APART FROM THE MARK AS SHOWN.

CLASS 24—FABRICS

FOR BED LINENS, NAMELY, BED SHEETS, BED BLANKETS, PILLOWCASES, PILLOW SHAMS, BED SKIRTS, BED SPREADS, DUVET COVERS, COMFORTERS, AND MATTRESS PADS; BATH LINENS, NAMELY, BATH TOWELS, BATH SHEETS, HAND TOWELS, WASH CLOTHS, FACE CLOTHS, TOWEL WRAPS (U.S. CLS. 42 AND 50).

CLASS 25—CLOTHING

FOR ROBES; SLIPPERS (U.S. CLS. 22 AND 39).
ALYSSA STEEL, EXAMINING ATTORNEY

SN 85-146,858. BURLING LIMITED, ROAD TOWN, TORTOLA, BR. VIRGIN ISLANDS, FILED 10-6-2010.



THE COLOR(S) GREEN IS/ARE CLAIMED AS A FEATURE OF THE MARK.

THE MARK CONSISTS OF THE WORD "BOSSINI" AND, TO THE RIGHT OF THE WORDING, A DESIGN ELEMENT COMPRISING A STYLIZED LAMP, COMPRISING TWO CIRCLES INSIDE OF A RECTANGLE WITH ROUNDED EDGES ALL ENCLOSED IN A SHADED OVAL THAT BREAKS AT THE BOTTOM. THE ENTIRE MARK APPEARS IN THE COLOR GREEN. THE COLOR WHITE REPRESENTS BACKGROUND, OUTLINING, SHADING AND/OR TRANSPARENT AREAS AND IS NOT PART OF THE MARK.

CLASS 18—LEATHER GOODS

FOR LEATHER AND IMITATIONS OF LEATHER, LEATHER AND IMITATIONS OF LEATHER GOODS, NAMELY, CASES, BAGS, HANDBAGS, AND WALLETS; ANIMAL SKINS AND HIDES; TRUNKS AND TRAVELLING BAGS; UMBRELLAS, PARASOLS AND WALKING STICKS; WHIPS, HARNESS AND SADDLERY; CASES, NAMELY, LEATHER CASES, KEY CASES, VANITY AND COSMETIC CASES SOLD EMPTY, ATTACHE CASES, BRIEFCASES, CREDIT CARD CASES, BUSINESS CARD CASES, CARRYING CASES, CASES FOR KEYS, AND TRAVELLING CASES, BAGS, NAMELY, TRUNKS, TRAVELLING BAGS, HANDBAGS, AND ALL PURPOSE CARRYING BAGS; WALLETS; BELTS, NAMELY, SADDLE BELTS AND LEATHER SHOULDER BELTS (U.S. CLS. 1, 2, 3, 22 AND 41).

CLASS 25—CLOTHING

FOR CLOTHING, NAMELY, SUITS, SHIRTS, T-SHIRTS, POLO SHIRTS, TROUSERS, SHORTS, SKIRTS, SWEATERS, CARDIGANS, SUSPENDERS, TRACKSUITS, SCARVES, KERCHIEFS, COATS, JACKETS, SWEATSHIRTS, GLOVES, JEANS, BELTS, TIES, NIGHTWEAR, UNDERWEAR, SOCKS, SWIMSUITS, LEGGINGS, APRONS, VESTS, BOXERS, CAPS, BLAZERS, DRESSES, SLIPPERS, PANTS, CAMISOLES, AND CAPRIS; FOOTWEAR; HEADGEAR, NAMELY, HATS, CAPS, BERETS, HEADBANDS, BANDANAS, BATHING CAPS, BEANIES, SKULL CAPS, AND VISORS; BELTS (U.S. CLS. 22 AND 39).

CLASS 35—ADVERTISING AND BUSINESS

FOR ADVERTISING; BUSINESS MANAGEMENT; BUSINESS ADMINISTRATION; PROVIDING OFFICE FUNCTIONS; RETAIL STORE SERVICES AND RETAIL STORE SERVICES VIA THE INTERNET FEATURING EYEWEAR, SUNGLASSES, PRECIOUS METALS AND THEIR ALLOYS AND GOODS IN PRECIOUS METALS OR COATED THEREWITH, NAMELY, JEWELRY FINDINGS, CUTLERY, BOXES, CHARMS, CUFF LINKS, DECORATIVE BOXES, FIGURINES, KEY CHAINS, ORNAMENTS, BOOK MARKERS, LETTER OPENERS, AND BELT BUCKLES, JEWELRY, PRECIOUS STONES, HOROLOGICAL AND CHRONOMETRIC INSTRUMENTS, WATCHES, TIMEPIECES, LEATHER AND IMITATIONS OF LEATHER, AND GOODS MADE OF THESE MATERIALS, NAMELY, LEATHER HANDBAGS AND LEATHER KEY CHAINS, ANIMAL SKINS, HIDES, TRUNKS AND TRAVELLING BAGS, UMBRELLAS, PARASOLS AND WALKING STICKS, WHIPS, HARNESS AND SADDLERY, CASES, BAGS, WALLETS, BELTS, CLOTHING, FOOTWEAR, AND HEADGEAR (U.S. CLS. 100, 101 AND 102).

Laurie Kaufman, Examining Attorney

SN 85-147,957. IGENICA, INC., BURLINGAME, CA. FILED 10-7-2010.



THE MARK CONSISTS OF "IGENICA" WITH A CIRCLE AND TWO VERTICAL LINES NEXT TO THE MARK.

CLASS 42—SCIENTIFIC AND COMPUTER SERVICES

FOR DRUG DISCOVERY SERVICES IN THE FIELD OF CANCER (U.S. CLS. 100 AND 101).

CLASS 44—MEDICAL, BEAUTY AND AGRICULTURAL SERVICES

FOR MEDICAL DIAGNOSTIC TESTING FOR THE DETECTION OF ANTIGENS (U.S. CLS. 100 AND 101).
VERNA BETH RIRIE, EXAMINING ATTORNEY

SN 85-148,252. BRUNSWICK NEWS INC., ST JOHN, NEW BRUNSWICK, CANADA, FILED 10-8-2010.

BONSHAW

THE MARK CONSISTS OF STANDARD CHARACTERS WITHOUT CLAIM TO ANY PARTICULAR FONT, STYLE, SIZE, OR COLOR.

PRIORITY CLAIMED UNDER SEC. 44(D) ON CANADA APPLICATION NO. 1478293, FILED 4-23-2010.

CLASS 9—ELECTRICAL AND SCIENTIFIC APPARATUS

FOR DOWNLOADABLE ELECTRONIC NEWSPAPERS DISTRIBUTED VIA THE INTERNET AND ELECTRONIC MAIL (U.S. CLS. 21, 23, 26, 36 AND 38).

CLASS 16—PAPER GOODS AND PRINTED MATTER

FOR PRINTED NEWSPAPERS; PRINTED PUBLICATIONS, NAMELY, BOOKS, MAGAZINES, NEWSLETTERS, JOURNALS AND NEWSPAPERS IN THE FIELD OF GENERAL INTEREST (U.S. CLS. 2, 5, 22, 23, 29, 37, 38 AND 50).

CLASS 35—ADVERTISING AND BUSINESS

FOR ADVERTISING SERVICES, NAMELY, PROMOTING THE GOODS AND SERVICES OF OTHERS THROUGH PLACING ADVERTISING ON AN INTERACTIVE NEWS WEBSITE; ADVERTISING SERVICES, NAMELY, PROMOTING THE GOODS AND SERVICES OF OTHERS BY PLACING ADVERTISEMENTS IN NEWSPAPERS, NEWSPAPER INSERTS, SPECIAL ADVERTISING SUPPLEMENTS AND EDITIONS OF NEWSPAPERS; CONDUCTING PUBLIC RELATIONS CAMPAIGNS THROUGH PUBLIC SERVICE ANNOUNCEMENTS PUBLISHED VIA PLACING ADVERTISEMENTS IN NEWSPAPERS, NEWSPAPER INSERTS, SPECIAL ADVERTISING SUPPLEMENTS AND EDITIONS OF NEWSPAPERS; PROVIDING JOB AND CAREER INFORMATION BY WAY OF ADVERTISING CAREER, EMPLOYMENT AND JOB OPPORTUNITIES AND CAREER COUNSELING TOPICS VIA THE INTERNET; CAREER AND EMPLOYMENT RELATED ADVERTISING SERVICES OFFERED ON BEHALF OF EMPLOYERS AND CAREER SEEKERS BY WAY OF A WEBSITE ON THE INTERNET; DISSEMINATION OF INFORMATION BY WAY OF ELECTRONIC MAIL ON CAREER OPPORTUNITIES AND GENERAL CAREER-RELATED INFORMATION; ADVERTISING FLYER DISTRIBUTION; PROVIDING AN INTERACTIVE WEBSITE IN THE FIELD OF AUTOMOTIVE, REAL ESTATE AND CLASSIFIED ADVERTISEMENTS; ONLINE AUCTION SERVICES; ONLINE BUSINESS DIRECTORIES; POSTING OF TENDER NOTICES ONLINE; ADVERTISING THE WARES AND SERVICES OF OTHERS; RENTAL OF ADVERTISING SPACE; CAREER INFORMATION SERVICES (U.S. CLS. 100, 101 AND 102).

CLASS 38—COMMUNICATION

FOR INTERNET BROADCASTING OF NEWS AND ENTERTAINMENT PROGRAMS (U.S. CLS. 100, 101 AND 104).

CLASS 41—EDUCATION AND ENTERTAINMENT

FOR NEWSPAPER PUBLISHING; PROVIDING ONLINE NON-DOWNLOADABLE NEWSPAPERS; NEWS AGENCIES, NAMELY, THE GATHERING AND DISSEMINATION OF NEWS; EDUCATIONAL SERVICES, NAMELY, CONDUCTING CLASSES AND WORKSHOPS IN THE FIELD OF CAREER MANAGEMENT, CAREER PLANNING, RELOCATION PLANNING AND CAREER DEVELOPMENT VIA THE INTERNET (U.S. CLS. 100, 101 AND 107).

CLASS 42—SCIENTIFIC AND COMPUTER SERVICES

FOR PROVIDING OBITUARIES, MEMORIALS AND INFORMATION RELATED TO FUNERALS VIA THE INTERNET; PROVIDING AN INTERACTIVE WEBSITE FEATURING TECHNOLOGY THAT ALLOWS USERS TO ENTER TEXT, PHOTOS AND IMAGES TO CREATE MEMORIALS (U.S. CLS. 100 AND 101).

DAWN FELDMAN, EXAMINING ATTORNEY

SN 85-148,318. ONDINE BIOMEDICAL, INC., FORMERLY ONDINE BIOPHARMA CORP., VANCOUVER, BC V6E 4A6, CANADA, FILED 10-8-2010.

ONDINE BIOMEDICAL

THE MARK CONSISTS OF STANDARD CHARACTERS WITHOUT CLAIM TO ANY PARTICULAR FONT, STYLE, SIZE, OR COLOR.

OWNER OF U.S. REG. NO. 3,545,082.

NO CLAIM IS MADE TO THE EXCLUSIVE RIGHT TO USE "BIOMEDICAL", APART FROM THE MARK AS SHOWN.

CLASS 5—PHARMACEUTICALS

FOR PHOTOSENSITIZING COMPOSITIONS FOR MEDICAL APPLICATIONS FOR USE IN PHOTODYNAMIC THERAPY AND/OR PHOTODISINFECTION, NAMELY, PHARMACEUTICAL PREPARATIONS FOR THE TREATMENT OF INFECTIOUS DISEASES (U.S. CLS. 6, 18, 44, 46, 51 AND 52).

CLASS 10—MEDICAL APPARATUS

FOR LIGHT DELIVERY DEVICES, NAMELY, LASERS FOR MEDICAL USE AND STERILIZABLE LIGHT WANDS FOR MEDICAL USE, ALL FOR USE IN THE FIELDS OF PHOTODYNAMIC THERAPY AND PHOTODISINFECTION (U.S. CLS. 26, 39 AND 44).

SETH A. RAPPAPORT, EXAMINING ATTORNEY

SN 85-149,348. TRUVIEW RESEARCH, LLC, AUSTIN, TX, FILED 10-11-2010.



NO CLAIM IS MADE TO THE EXCLUSIVE RIGHT TO USE "RESEARCH", APART FROM THE MARK AS SHOWN.

THE MARK CONSISTS OF 3 FANCIFUL TV SCREENS POSITIONED SIDE BY SIDE TO FORM 1 SCREEN DISPLAYING 5 MALE SILHOUETTES STANDING SHOULDER TO SHOULDER IN DIFFERENT GRAYSCALE SHADINGS WITH THE TV SCREENS OVER THE WORDS "TRUVIEW RESEARCH AROUND THE WORLD. ACROSS THE TABLE".

CLASS 35—ADVERTISING AND BUSINESS

FOR BUSINESS SERVICES, NAMELY, OPERATING TELEPRESENCE ENVIRONMENTS OF OTHERS, NAMELY, MANAGING TELEPRESENCE ENVIRONMENTS FOR OTHERS; BUSINESS RESEARCH USING FOCUS GROUPS, NAMELY, PROVIDING FOCUS GROUP SUPPORT SERVICES TO MARKET RESEARCH COMPANIES, INCLUDING FOOD/BEVERAGES TO FOCUS GROUP PARTICIPANTS AND MAKING INCENTIVE PAYMENTS (U.S. CLS. 100, 101 AND 102).

FIRST USE 10-13-2010; IN COMMERCE 10-13-2010.

CLASS 38—COMMUNICATION

FOR PROVIDING VIDEO TELECONFERENCING FACILITIES TO MARKET RESEARCH COMPANIES; PROVIDING TELEPRESENCE CONFERENCING SERVICES (U.S. CLS. 100, 101 AND 104).

FIRST USE 10-13-2010; IN COMMERCE 10-13-2010.
BENJAMIN OKEKE, EXAMINING ATTORNEY

SN 85-149,367. TILE COUNCIL OF NORTH AMERICA, INC., DBA TCNA, ANDERSON, SC. FILED 10-11-2010.

GREEN SQUARED

THE MARK CONSISTS OF STANDARD CHARACTERS WITHOUT CLAIM TO ANY PARTICULAR FONT, STYLE, SIZE, OR COLOR.

NO CLAIM IS MADE TO THE EXCLUSIVE RIGHT TO USE "GREEN", APART FROM THE MARK AS SHOWN.

CLASS 19—NON-METALLIC BUILDING MATERIALS

FOR NON-METAL TILES PRODUCED USING ECOLOGICALLY SUSTAINABLE METHODS (U.S. CLS. 1, 12, 33 AND 50).

CLASS 41—EDUCATION AND ENTERTAINMENT

FOR EDUCATION SERVICES, NAMELY, PROVIDING WORKSHOPS, SEMINARS AND TRAINING IN THE FIELD OF ECOLOGICALLY SUSTAINABLE STANDARDS AND METHODS FOR TILE AND THE MANUFACTURING OF TILE (U.S. CLS. 100, 101 AND 107).

CLASS 42—SCIENTIFIC AND COMPUTER SERVICES

FOR ACCREDITATION SERVICES, NAMELY, SETTING AND PROVIDING STANDARDS FOR ECOLOGICALLY SUSTAINABLE TILE AND TILE MANUFACTURING FOR THE PURPOSE OF ACCREDITATION (U.S. CLS. 100 AND 101).

JOHN WILKE, EXAMINING ATTORNEY

SN 85-149,592. X-COM SYSTEMS, LLC, SOLON, OH. FILED 10-11-2010.

X-COM SYSTEMS

THE MARK CONSISTS OF STANDARD CHARACTERS WITHOUT CLAIM TO ANY PARTICULAR FONT, STYLE, SIZE, OR COLOR.

NO CLAIM IS MADE TO THE EXCLUSIVE RIGHT TO USE "SYSTEMS", APART FROM THE MARK AS SHOWN.

CLASS 9—ELECTRICAL AND SCIENTIFIC APPARATUS

FOR SOFTWARE ANALYSIS TOOLS FOR RADIO FREQUENCY (RF) DATA CAPTURE AND STORAGE; AND RADIO FREQUENCY (RF) ANALYSIS PRODUCTS, NAMELY, RF DATA RECORDERS AND RF SIGNAL GENERATORS (U.S. CLS. 21, 23, 26, 36 AND 38).

CLASS 40—MATERIAL TREATMENT

FOR MANUFACTURE OF CUSTOM RADIO FREQUENCY (RF) DATA CAPTURE, STORAGE, AND ANALYSIS PRODUCTS, NAMELY, RF DATA RECORDERS, RF SIGNAL GENERATORS, AND SOFTWARE ANALYSIS TOOLS TO ORDER AND/OR SPECIFICATION OF OTHERS (U.S. CLS. 100, 103 AND 106).

CLASS 42—SCIENTIFIC AND COMPUTER SERVICES

FOR DESIGN OF RADIO FREQUENCY (RF) DATA CAPTURE, STORAGE, AND ANALYSIS PRODUCTS, NAMELY, RF DATA RECORDERS, RF SIGNAL GENERATORS, AND SOFTWARE ANALYSIS TOOLS FOR OTHERS (U.S. CLS. 100 AND 101).

NAAKWAMA ANKRAH, EXAMINING ATTORNEY

SN 85-150,507. THE HANDEL GROUP, LLC, RIDGEFIELD, CT. FILED 10-12-2010.



HandelGroup

OWNER OF U.S. REG. NO. 3,878,963.

NO CLAIM IS MADE TO THE EXCLUSIVE RIGHT TO USE "GROUP", APART FROM THE MARK AS SHOWN.

THE MARK CONSISTS OF AN UPPER-CASE "H" PLACED ADJACENT TO A LOWER-CASE "G". BOTH LETTERS APPEAR IN THE UPPER-HALF OF A SHADED RECTANGLE, WITH A SHADOW BENEATH THE RECTANGLE. THE WORDING "HANDELGROUP" IS DIRECTLY BELOW THE RECTANGLE.

CLASS 41—EDUCATION AND ENTERTAINMENT

FOR BUSINESS EDUCATION AND TRAINING SERVICES, NAMELY, PROVIDING EXECUTIVE COACHING SERVICES; LIFE COACHING SERVICES IN THE FIELD OF LIFE, BUSINESS AND CAREER SKILLS; EDUCATIONAL SERVICES, NAMELY, PROVIDING WORKSHOPS, CLASSES AND SEMINARS IN THE FIELDS OF LEADERSHIP DEVELOPMENT, LIFE COACHING, AND EXECUTIVE COACHING; BUSINESS TRAINING CONSULTANCY SERVICES IN THE FIELDS OF EMPLOYEE DEVELOPMENT AND EXECUTIVE DEVELOPMENT (U.S. CLS. 100, 101 AND 107).

FIRST USE 12-31-2007; IN COMMERCE 12-31-2007.

CLASS 45—PERSONAL AND LEGAL SERVICES

FOR ALTERNATIVE DISPUTE RESOLUTION SERVICES (U.S. CLS. 100 AND 101).
FIRST USE 12-31-2007; IN COMMERCE 12-31-2007.
DAVID HOFFMAN, EXAMINING ATTORNEY

CLASS 42—SCIENTIFIC AND COMPUTER SERVICES

FOR RESEARCH, AND DESIGN AND DEVELOPMENT OF PRODUCTS FOR OTHERS IN THE FIELD OF AUDIO EQUIPMENT, APPARATUS, COMPONENTS AND ACCESSORIES USED FOR CAPTURING, EXTRACTING, TRANSMITTING AND REPRODUCING FREQUENCY, AMPLITUDE, AND PHASE INFORMATION TO MAKE SOUND, AND FOR GENERATING, PROCESSING, ENHANCING, CONTROLLING, PRODUCING, REPRODUCING, RECORDING, TRANSMITTING, AND PLAYING AUDIO SIGNALS, FILES, AND SOUNDS; TECHNICAL CONSULTATION IN THE FIELD OF ENGINEERING OF AUDIO EQUIPMENT, APPARATUS, COMPONENTS AND ACCESSORIES USED FOR CAPTURING, EXTRACTING, TRANSMITTING AND REPRODUCING FREQUENCY, AMPLITUDE, AND PHASE INFORMATION TO MAKE SOUND, AND FOR GENERATING, PROCESSING, ENHANCING, CONTROLLING, PRODUCING, REPRODUCING, RECORDING, TRANSMITTING, AND PLAYING AUDIO SIGNALS, FILES, AND SOUNDS (U.S. CLS. 100 AND 101).

SN 85-150,704. BSG TECHNOLOGIES, LLC, MARINA DEL REY, CA. FILED 10-12-2010.

CLASS 45—PERSONAL AND LEGAL SERVICES

FOR LICENSING OF INTELLECTUAL PROPERTY (U.S. CLS. 100 AND 101).
ANDREA HACK, EXAMINING ATTORNEY



THE COLOR(S) GRAY, BLUE, GREEN AND WHITE IS/ARE CLAIMED AS A FEATURE OF THE MARK.

THE MARK CONSISTS OF THE GRAY WORDING "IT'S EVERYTHING YOU'VE NEVER HEARD BEFORE" ABOVE A GRAY SEMI-CIRCLE FROM THE LEFT AND A GREEN SEMI-CIRCLE FROM THE RIGHT, SURROUNDING A WHITE AREA CONTAINING A BLUE OVAL. INSIDE THE OVAL IS THE WORDING "QØL" IN WHITE, WITH PARTS OF THE "Q" AND "L" MEETING UP WITH THE WHITE AREA BETWEEN THE OVAL AND THE SEMI-CIRCLES.

THE ENGLISH TRANSLATION OF "QØL" IN THE MARK IS UNIVERSE OR EVERYTHING.

SN 85-151,306. JACOB'S LADDER MUSIC LLC, MIAMI BEACH, FL. FILED 10-13-2010.

CLASS 9—ELECTRICAL AND SCIENTIFIC APPARATUS

FOR SOUND EQUIPMENT, NAMELY, ELECTRONIC AUDIO REPRODUCTION EQUIPMENT IN THE FORM OF MICROPHONES, SPEAKERS, CABLES, WIRES, INTERCONNECTS AND CONNECTORS USED TO CAPTURE, EXTRACT, TRANSMIT AND REPRODUCE FREQUENCY, AMPLITUDE, AND PHASE INFORMATION TO MAKE SOUND. COMPUTER PROGRAMS, COMPUTER SOFTWARE, COMPUTER HARDWARE AND COMPONENTS OF COMPUTERS AND OTHER DIGITAL DEVICES, NAMELY, MICROPHONES, SPEAKERS, ALGORITHMS, INTEGRATED CIRCUITS, CIRCUIT BOARDS, SOUND CARDS AND DRIVERS USED FOR CAPTURING, EXTRACTING, TRANSMITTING AND REPRODUCING FREQUENCY, AMPLITUDE, AND PHASE INFORMATION TO MAKE SOUND, AND FOR MEASURING, ANALYZING, CONTROLLING, TESTING, PRODUCING, REPRODUCING, RECORDING, TRANSMITTING, AND PLAYING, AUDIO SIGNALS, FILES, AND SOUNDS (U.S. CLS. 21, 23, 26, 36 AND 38).

JACOBS LADDER

THE MARK CONSISTS OF STANDARD CHARACTERS WITHOUT CLAIM TO ANY PARTICULAR FONT, STYLE, SIZE, OR COLOR.

CLASS 9—ELECTRICAL AND SCIENTIFIC APPARATUS

FOR COMPACT DISCS FEATURING MUSIC; COMPUTER SOFTWARE FEATURING MUSICAL SOUND RECORDINGS AND MUSICAL VIDEO RECORDINGS; DOWNLOADABLE MP3 FILES, MP3 RECORDINGS, ON-LINE DISCUSSION BOARDS, WEBCASTS, WEBINARS AND PODCASTS FEATURING MUSIC, AUDIO BOOKS IN THE FIELD OF LIVE AND RECORDED MUSIC, INTERVIEWS, NEWS, DISCUSSIONS AND SPOKEN-WORD PERFORMANCES, AND NEWS BROADCASTS; DOWNLOADABLE MUSICAL SOUND RECORDINGS; DOWNLOADABLE RINGTONES, VIDEO FILES, STILL IMAGE FILES, LIVE AND RECORDED MUSIC, INTERVIEWS, NEWS, DISCUSSIONS AND SPOKEN-WORD PERFORMANCES VIA THE INTERNET AND WIRELESS DEVICES; ELECTRONIC PUBLICATIONS, NAMELY, NEWSLETTERS, MAGAZINES, NEWSPAPERS, NEWS UPDATES, FEATURE UPDATES, INTERVIEWS, BOOKS, CALENDARS, SCHEDULING MATERIALS, IMAGE COLLECTIONS, VIDEO COLLECTIONS, WEBINARS AND FILES CONTAINING IMAGES, TEXT, SOUND AND VIDEO FEATURING LIVE AND RECORDED MUSIC, INTERVIEWS, NEWS, DISCUSSIONS AND SPOKEN-WORD PERFORMANCES RECORDED ON COMPUTER MEDIA; MUSIC HEADPHONES; MUSICAL SOUND RECORDINGS; MUSICAL VIDEO RECORDINGS; PRE-RECORDED ELECTRONIC AND DIGITAL MEDIA FEATURING LIVE AND RECORDED MUSIC, INTERVIEWS, NEWS, DISCUSSIONS AND SPOKEN-WORD PERFORMANCES; PRE-RECORDED FLASH DRIVES FEATURING LIVE AND RECORDED MUSIC, INTERVIEWS, NEWS, DISCUSSIONS AND SPOKEN-WORD PERFORMANCES; VINYL COVERS SPECIALLY ADAPTED FOR CELL PHONES, MP3 PLAYERS, LAPTOPS, COMPUTERS, PORTABLE SATELLITE RADIOS, PERSONAL DIGITAL ASSISTANTS, REMOTE CONTROLS, AND TELEVISION SATELLITE RECORDERS; VISUAL AND AUDIO RECORDINGS FEATURING LIVE AND RECORDED MUSIC, INTERVIEWS, NEWS, DISCUSSIONS AND SPOKEN-WORD PERFORMANCES (U.S. CLS. 21, 23, 26, 36 AND 38).

FIRST USE 6-1-2002; IN COMMERCE 6-1-2002.

CLASS 25—CLOTHING

FOR ATHLETIC APPAREL, NAMELY, SHIRTS, PANTS, JACKETS, FOOTWEAR, HATS AND CAPS, ATHLETIC UNIFORMS; CAMP SHIRTS; COLLARED SHIRTS; GLOVES AS CLOTHING; HATS; HOODED SWEAT SHIRTS; JACKETS; JERSEYS; LEATHER BELTS; NIGHT SHIRTS; OVER SHIRTS; PAPER HATS FOR USE AS CLOTHING ITEMS; SHIRTS; SHIRTS FOR INFANTS, BABIES, TODDLERS AND CHILDREN; SHOES; SOCKS; T-SHIRTS; TIES; TOPS; UNDERWEAR; WRAPS (U.S. CLS. 22 AND 39).

FIRST USE 6-1-2002; IN COMMERCE 6-1-2002.

CLASS 41—EDUCATION AND ENTERTAINMENT

FOR ENTERTAINMENT IN THE NATURE OF LIVE MUSICAL PERFORMANCES; ENTERTAINMENT SERVICES, NAMELY, PROVIDING A WEB SITE FEATURING NON-DOWNLOADABLE MUSICAL PERFORMANCES, MUSICAL VIDEOS, RELATED FILM CLIPS, PHOTOGRAPHS, AND OTHER MULTIMEDIA MATERIALS FEATURING MUSICAL PERFORMANCES; ENTERTAINMENT, NAMELY, LIVE PERFORMANCES BY A MUSICAL BAND; PROVISION OF INFORMATION RELATING TO LIVE PERFORMANCES, ROAD SHOWS, LIVE STAGE EVENTS, THEATRICAL PERFORMANCES, LIVE MUSIC CONCERTS AND AUDIENCE PARTICIPATION IN SUCH EVENTS (U.S. CLS. 100, 101 AND 107).

FIRST USE 7-1-2001; IN COMMERCE 10-20-2001.
DAVID H. STINE, EXAMINING ATTORNEY

SN 85-151,793. NATIONAL PARKINSON FOUNDATION, INC., MIAMI, FL. FILED 10-13-2010.



NO CLAIM IS MADE TO THE EXCLUSIVE RIGHT TO USE "PARKINSON FOUNDATION", APART FROM THE MARK AS SHOWN.

THE COLOR(S) BLUE AND GREY IS/ARE CLAIMED AS A FEATURE OF THE MARK.

THE MARK CONSISTS OF A STYLIZED LETTER "P" WITH THE WORDING "NATIONAL PARKINSON FOUNDATION" TO ITS LEFT WITHIN STYLIZED LETTERING. THE WORD "NATIONAL" IS PLACED IN A VERTICAL POSITION NEXT TO THE WORDING "PARKINSON FOUNDATION". THE STYLIZED "P" AND THE WORD "PARKINSON" ARE BLUE. THE WORDING "NATIONAL" AND "FOUNDATION" ARE GREY.

SEC. 2(F) AS TO "NATIONAL PARKINSON FOUNDATION".

CLASS 9—ELECTRICAL AND SCIENTIFIC APPARATUS

FOR ELECTRONIC DOWNLOADABLE PUBLICATIONS IN THE NATURE OF PAMPHLETS, BOOKS, NEWSLETTERS, BROCHURES AND INFORMATIONAL FLYERS IN THE FIELDS OF MEDICINE AND CARE GIVING IN THE FIELD OF PARKINSON'S DISEASE (U.S. CLS. 21, 23, 26, 36 AND 38).

CLASS 16—PAPER GOODS AND PRINTED MATTER

FOR PRINTED PAMPHLETS, BOOKS, NEWSLETTERS, BROCHURES AND INFORMATIONAL FLYERS IN THE FIELDS OF MEDICINE AND CAREGIVING IN THE FIELD OF PARKINSON'S DISEASE (U.S. CLS. 2, 5, 22, 23, 29, 37, 38 AND 50).

CLASS 35—ADVERTISING AND BUSINESS

FOR CHARITABLE SERVICES, NAMELY, PROMOTING AND SUPPORTING PUBLIC AWARENESS OF PARKINSON'S DISEASE THROUGH BASIC SCIENTIFIC RESEARCH ABOUT PARKINSON'S DISEASE AND THROUGH SUPPORT GROUPS AND THROUGH AN ON-LINE COMPUTER WEBSITE (U.S. CLS. 100, 101 AND 102).

CLASS 36—INSURANCE AND FINANCIAL

FOR CHARITABLE FUND RAISING FOR THE BENEFIT OF KNOWLEDGE ABOUT PARKINSON'S DISEASE (U.S. CLS. 100, 101 AND 102).

CLASS 41—EDUCATION AND ENTERTAINMENT

FOR WRITING OF SCHOLARLY ARTICLES, RESEARCH REPORTS AND PAPERS ABOUT PARKINSON'S DISEASE; PROVIDING EDUCATIONAL SEMINARS, WORKSHOPS, ON-LINE SEMINARS, CONFERENCES AND COURSES FOR GOVERNMENT MEDICAL RESEARCH DECISION MAKERS, PATIENTS, CARE GIVERS, AND THE PUBLIC IN THE FIELD OF PARKINSON'S DISEASE; CONDUCTING MEDICAL, NURSING, CARE-GIVER AND PATIENT PANEL DISCUSSIONS, CONGRESSES, SYMPOSIA, CLASSES, SEMINARS, CONFERENCES AND WORKSHOPS ABOUT PARKINSON'S DISEASE; PUBLISHING OF ELECTRONIC PUBLICATIONS AND PRINTED MATTER, NAMELY, PAMPHLETS, BOOKS, NEWSLETTERS AND BROCHURES ABOUT PARKINSON'S DISEASE; CONDUCTING CONFERENCES, WORKSHOPS AND ON-LINE SEMINARS FOR PARKINSON'S DISEASE PATIENTS AND THEIR CAREGIVERS (U.S. CLS. 100, 101 AND 107).

CLASS 44—MEDICAL, BEAUTY AND AGRICULTURAL SERVICES

FOR HEALTH CARE SERVICES, NAMELY, PROVIDING A DATABASE IN THE FIELD OF PARKINSON'S DISEASE INFORMATION AND FEATURING INPUTTING AND COLLECTION OF DATA AND INFORMATION ALL FOR TREATMENT AND DIAGNOSTIC PURPOSES (U.S. CLS. 100 AND 101).

KEVON CHISOLM, EXAMINING ATTORNEY

SN 85-151,923, UTILITY ASSOCIATES, INC., TUCKER, GA. FILED 10-13-2010.



NO CLAIM IS MADE TO THE EXCLUSIVE RIGHT TO USE "UTILITY", APART FROM THE MARK AS SHOWN.

THE MARK CONSISTS OF THE LETTER "U" WITH AN INVERTED LETTER "U" NESTED THEREWITH, AND THE WORD "UTILITY".

CLASS 9—ELECTRICAL AND SCIENTIFIC APPARATUS

FOR COMPUTER HARDWARE, NAMELY, WIRELESS ACCESS POINT (WAP) DEVICES (U.S. CLS. 21, 23, 26, 36 AND 38).

FIRST USE 10-5-2010; IN COMMERCE 10-5-2010.

CLASS 42—SCIENTIFIC AND COMPUTER SERVICES

FOR APPLICATION SERVICE PROVIDER (ASP) FEATURING SOFTWARE FOR USE WITH WIRELESS MOBILE DEVICES (U.S. CLS. 100 AND 101).

FIRST USE 10-5-2010; IN COMMERCE 10-5-2010.
LINDA ORNDORFF, EXAMINING ATTORNEY

SN 85-152,689, RSI HOME PRODUCTS MANAGEMENT, INC., ANAHEIM, CA. FILED 10-14-2010.

CONTINENTAL CABINETS

THE MARK CONSISTS OF STANDARD CHARACTERS WITHOUT CLAIM TO ANY PARTICULAR FONT, STYLE, SIZE, OR COLOR.

OWNER OF U.S. REG. NO. 1,664,930.

NO CLAIM IS MADE TO THE EXCLUSIVE RIGHT TO USE "CABINETS", APART FROM THE MARK AS SHOWN.

CLASS 6—METAL GOODS

FOR GENERAL PURPOSE METAL WIRE STORAGE BINS AND CONTAINERS; METAL STORAGE SHEDS (U.S. CLS. 2, 12, 13, 14, 23, 25 AND 50).

CLASS 11—ENVIRONMENTAL CONTROL APPARATUS

FOR SINKS; BATHROOM VANITY TOPS AND SINK BOWL UNITS (U.S. CLS. 13, 21, 23, 31 AND 34).

CLASS 19—NON-METALLIC BUILDING MATERIALS

FOR NON-METAL COUNTERTOPS FOR FURTHER INSTALLATION (U.S. CLS. 1, 12, 33 AND 50).

CLASS 20—FURNITURE AND ARTICLES NOT OTHERWISE CLASSIFIED

FOR CABINETS, INCLUDING KITCHEN CABINETS, CLOSET CABINETS, BATHROOM CABINETS, MEDICINE CABINETS, MIRRORED CABINETS, GARAGE CABINETS, AND STORAGE CABINETS; BATHROOM VANITIES; FURNITURE MIRRORS; FURNITURE PARTS; STORAGE AND ORGANIZATION SYSTEMS COMPRISING SHELVES, DRAWERS, CUPBOARDS, BASKETS AND CLOTHES RODS, SOLD AS A UNIT; STORAGE ACCESSORIES, NAMELY, NON-METAL FIXTURES COMPRISING SUPPORT ARMS FOR HANGING GENERAL HOUSEHOLD GOODS, NAMELY, BARS FOR HANGING CLOTHES, CLOTHES RODS, STORAGE RACKS AND SLIDING CLOTHES RAILS; CLOTHES HANGERS, STORAGE RACKS, SHOE RACKS, BELT RACKS AND TIE RACKS; GARAGE STORAGE RACKS FOR GENERAL USE AND GARAGE SHELVING; WORK BENCHES; WALL-MOUNTED TOOL RACKS (U.S. CLS. 2, 13, 22, 25, 32 AND 50).

CLASS 21—HOUSEWARES AND GLASS

FOR PLASTIC GARAGE STORAGE CONTAINERS FOR DOMESTIC USE; ALL PURPOSE CONTAINERS FOR HOUSEHOLD USE; LAZY SUSANS; PLASTIC STORAGE BINS AND CONTAINERS FOR DOMESTIC USE (U.S. CLS. 2, 13, 23, 29, 30, 33, 40 AND 50).

BENJAMIN OKEKE, EXAMINING ATTORNEY

SN 85-152,696. RSI HOME PRODUCTS MANAGEMENT, INC., ANAHEIM, CA. FILED 10-14-2010.

SN 85-152,805. DELAVE, LLC, BENSALEM, PA. FILED 10-14-2010.



OWNER OF U.S. REG. NO. 1,664,930.
NO CLAIM IS MADE TO THE EXCLUSIVE RIGHT TO USE "CABINETS", APART FROM THE MARK AS SHOWN.
THE MARK CONSISTS OF THE WORDS "CONTINENTAL CABINETS" AND WAVY LINES RESEMBLING A FLAG.

CLASS 6—METAL GOODS

FOR GENERAL PURPOSE METAL WIRE STORAGE BINS AND CONTAINERS; METAL STORAGE SHEDS (U.S. CLS. 2, 12, 13, 14, 23, 25 AND 50).

CLASS 11—ENVIRONMENTAL CONTROL APPARATUS

FOR SINKS; BATHROOM VANITY TOPS AND SINK BOWL UNITS (U.S. CLS. 13, 21, 23, 31 AND 34).

CLASS 19—NON-METALLIC BUILDING MATERIALS

FOR NON-METAL COUNTERTOPS FOR FURTHER INSTALLATION (U.S. CLS. 1, 12, 33 AND 50).

CLASS 20—FURNITURE AND ARTICLES NOT OTHERWISE CLASSIFIED

FOR CABINETS, INCLUDING KITCHEN CABINETS, CLOSET CABINETS, BATHROOM CABINETS, MEDICINE CABINETS, MIRRORED CABINETS, GARAGE CABINETS, AND STORAGE CABINETS; BATHROOM VANITIES; FURNITURE MIRRORS; FURNITURE PARTS; STORAGE AND ORGANIZATION SYSTEMS COMPRISING SHELVES, DRAWERS, CUPBOARDS, BASKETS AND CLOTHES RODS, SOLD AS A UNIT; STORAGE ACCESSORIES, NAMELY, NON-METAL FIXTURES COMPRISING SUPPORT ARMS FOR HANGING GENERAL HOUSEHOLD GOODS, NAMELY, BARS FOR HANGING CLOTHES, CLOTHES RODS, STORAGE RACKS AND SLIDING CLOTHES RAILS; CLOTHES HANGERS, STORAGE RACKS, SHOE RACKS, BELT RACKS AND TIE RACKS; GARAGE STORAGE RACKS FOR GENERAL USE AND GARAGE SHELVING; WORK BENCHES; WALL-MOUNTED TOOL RACKS (U.S. CLS. 2, 13, 22, 25, 32 AND 50).

CLASS 21—HOUSEWARES AND GLASS

FOR PLASTIC GARAGE STORAGE CONTAINERS FOR DOMESTIC USE; ALL PURPOSE CONTAINERS FOR HOUSEHOLD USE; LAZY SUSANS; PLASTIC STORAGE BINS AND CONTAINERS FOR DOMESTIC USE (U.S. CLS. 2, 13, 23, 29, 30, 33, 40 AND 50).
BENJAMIN OKEKE, EXAMINING ATTORNEY

TILT LUXURY

THE MARK CONSISTS OF STANDARD CHARACTERS WITHOUT CLAIM TO ANY PARTICULAR FONT, STYLE, SIZE, OR COLOR.

NO CLAIM IS MADE TO THE EXCLUSIVE RIGHT TO USE "LUXURY", APART FROM THE MARK AS SHOWN.

CLASS 25—CLOTHING

FOR CLOTHING, NAMELY, T SHIRTS, POLO SHIRTS, HATS, SWEATSHIRTS AND JACKETS (U.S. CLS. 22 AND 39).

CLASS 43—HOTEL AND RESTAURANT SERVICES

FOR RESTAURANT, BAR AND CATERING SERVICES (U.S. CLS. 100 AND 101).

KATHLEEN M. VANSTON, EXAMINING ATTORNEY

SN 85-153,070. SSE IP, LLC, NEW YORK, NY. FILED 10-14-2010.

SHAKE SHACK

THE MARK CONSISTS OF STANDARD CHARACTERS WITHOUT CLAIM TO ANY PARTICULAR FONT, STYLE, SIZE, OR COLOR.

OWNER OF U.S. REG. NOS. 3,186,610, 3,853,578 AND OTHERS.

NO CLAIM IS MADE TO THE EXCLUSIVE RIGHT TO USE "SHAKE", APART FROM THE MARK AS SHOWN.

CLASS 25—CLOTHING

FOR SHIRTS, TOPS, ONE-PIECE GARMENTS FOR INFANTS AND TODDLERS; HEADWEAR; FOOTWEAR (U.S. CLS. 22 AND 39).

FIRST USE 7-0-2004; IN COMMERCE 7-0-2004.

CLASS 30—STAPLE FOODS

FOR HAMBURGER SANDWICHES, HOT DOG SANDWICHES, MILK SHAKES AND FROZEN CUSTARD (U.S. CL. 46).

FIRST USE 6-0-2004; IN COMMERCE 6-0-2004.

SAIMA MAKHDOOM, EXAMINING ATTORNEY

SN 85-153,093. NEOWIZLAB CORP., SEOUL, REPUBLIC OF KOREA, FILED 10-14-2010.



PRIORITY CLAIMED UNDER SEC. 44(D) ON REPUBLIC OF KOREA APPLICATION NO. 452010000387, FILED 9-7-2010.

THE COLOR(S) PINK, AND WHITE IS/ARE CLAIMED AS A FEATURE OF THE MARK.

THE MARK CONSISTS OF LETTERS "PIN" IN WHITE COLOR ON THE FIRST LINE AND LETTERS "PIE" IN WHITE COLOR ON SECOND LINE, WHICH ARE LOCATED INSIDE OF PINK SPLOTCH-SHAPED HAVING WHITE FRINGE.

CLASS 9—ELECTRICAL AND SCIENTIFIC APPARATUS

FOR COMPUTER SOFTWARE FOR SOCIAL NETWORKING SERVICES; INSTANT MESSAGING COMPUTER SOFTWARE; DOWNLOADABLE COMPUTER PROGRAM FEATURING SOCIAL NETWORKING SERVICES (U.S. CLS. 21, 23, 26, 36 AND 38).

CLASS 38—COMMUNICATION

FOR PROVIDING INSTANT MESSENGER SERVICES VIA INTERNET AND WIRELESS NETWORKS; TRANSMISSION OF MESSAGES, IMAGES, VIDEOS, AND VOICES VIA INTERNET AND WIRELESS NETWORKS; WIRED AND WIRELESS INTERNET BROADCASTING; PROVIDING SOCIAL NETWORKING CHAT ROOM SERVICES VIA INTERNET AND WIRELESS NETWORKS; PROVIDING TELECOMMUNICATIONS CONNECTIONS TO GLOBAL COMPUTER NETWORKS; ELECTRONIC BULLETIN BOARD SERVICES (U.S. CLS. 100, 101 AND 104).

FONG HSU, EXAMINING ATTORNEY

SN 85-153,777. ORIZONIA DESTINATION MANAGEMENT, S.L., PALMA DE MALLORCA, SPAIN, FILED 10-15-2010.



OWNER OF SPAIN REG. NO. 2.841.104, DATED 2-6-2009, EXPIRES 8-14-2018.

OWNER OF SPAIN REG. NO. 2.841.103, DATED 2-6-2009, EXPIRES 8-14-2018.

OWNER OF SPAIN REG. NO. 2.841.102, DATED 2-6-2009, EXPIRES 8-14-2018.

NO CLAIM IS MADE TO THE EXCLUSIVE RIGHT TO USE "DESTINATION MANAGEMENT", APART FROM THE MARK AS SHOWN.

THE COLOR(S) DARK BLUE, ORANGE, GRAY, WHITE, RED, PINK, GREEN, LIGHT BLUE, AND YELLOW IS/ARE CLAIMED AS A FEATURE OF THE MARK.

THE MARK CONSISTS OF THE WORD "SMILO" IN DARK BLUE WITH AN ORANGE DOT OVER THE LETTER "I". THE LETTER "O" CONTAINS A FACE IN WHITE WITH GRAY EYES AND A GRAY MOUTH THAT EXTENDS TO THE RIGHT INTO A PINWHEEL WITH FIVE PRONGS, IN THE COLORS RED, PINK, GREEN, LIGHT BLUE, AND YELLOW. THE WORDS "DESTINATION MANAGEMENT" APPEAR IN GRAY COLOR BELOW "SMILO".

CLASS 16—PAPER GOODS AND PRINTED MATTER

FOR PRINTED PUBLICATIONS, NAMELY, TOURIST LEAFLETS AND BROCHURES (U.S. CLS. 2, 5, 22, 23, 29, 37, 38 AND 50).

CLASS 39—TRANSPORTATION AND STORAGE

FOR PROVIDING TRAVEL ARRANGEMENTS, GROUND TRANSPORT OF PASSENGERS, TICKET RESERVATION FOR THE AFORESAID MEANS OF TRANSPORT (U.S. CLS. 100 AND 105).

CLASS 43—HOTEL AND RESTAURANT SERVICES

FOR PROVIDING RESERVATION OF TEMPORARY ACCOMMODATIONS, SERVICES FOR PROVIDING FOOD, DRINK AND HOTEL TRADE SERVICES (U.S. CLS. 100 AND 101).

TEJBIR SINGH, EXAMINING ATTORNEY

SN 85-154,327. LEANDRA MEDINE, NEW YORK, NY, FILED 10-16-2010.

MAN REPELLER

THE MARK CONSISTS OF STANDARD CHARACTERS WITHOUT CLAIM TO ANY PARTICULAR FONT, STYLE, SIZE, OR COLOR.

CLASS 16—PAPER GOODS AND PRINTED MATTER

FOR PRINTED MATTER, NAMELY, A SERIES OF BOOKS AND ARTICLES IN THE FIELD OF FASHION AND STYLE NEWS, REVIEWS AND COMMENTARY (U.S. CLS. 2, 5, 22, 23, 29, 37, 38 AND 50).

CLASS 41—EDUCATION AND ENTERTAINMENT

FOR ON-LINE JOURNALS, NAMELY, BLOGS FEATURING FASHION AND STYLE NEWS, REVIEWS AND COMMENTARY (U.S. CLS. 100, 101 AND 107).

FIRST USE 4-25-2010; IN COMMERCE 4-25-2010.

CLASS 45—PERSONAL AND LEGAL SERVICES

FOR PROVIDING ON-LINE INFORMATION, NEWS AND COMMENTARY IN THE FIELD OF FASHION AND STYLE (U.S. CLS. 100 AND 101).

FIRST USE 4-25-2010; IN COMMERCE 4-25-2010.

ALYSSA STEEL, EXAMINING ATTORNEY

SN 85-155,093. COOPERATIVE REGIONS OF ORGANIC PRODUCER POOLS, LA FARGE, WI. FILED 10-18-2010.



NO CLAIM IS MADE TO THE EXCLUSIVE RIGHT TO USE "TV", APART FROM THE MARK AS SHOWN.

THE MARK CONSISTS OF THE TERM "FROG" FOLLOWED BY A FANCIFUL BULLS-EYE DESIGN FOLLOWED BY THE TERM "TV".

CLASS 41—EDUCATION AND ENTERTAINMENT

FOR ENTERTAINMENT SERVICES, NAMELY, PROVIDING ON-GOING WEBSITES FEATURING FOOD, HEALTH, AND THE ENVIRONMENT VIA A GLOBAL COMPUTER NETWORK (U.S. CLS. 100, 101 AND 107).

CLASS 44—MEDICAL, BEAUTY AND AGRICULTURAL SERVICES

FOR PROVIDING A WEB SITE FEATURING INFORMATION ABOUT FOOD, NAMELY, INFORMATION REGARDING NUTRITION AND DIET; PROVIDING A WEB SITE FEATURING INFORMATION ABOUT HEALTH (U.S. CLS. 100 AND 101).

MARK SHINER, EXAMINING ATTORNEY

SN 85-155,183. FLEET WHOLESALE SUPPLY CO., INC., APPLETON, WI. FILED 10-18-2010.



NO CLAIM IS MADE TO THE EXCLUSIVE RIGHT TO USE "HUNTER", APART FROM THE MARK AS SHOWN.

THE NAME IN OWNER'S MARK IDENTIFIES A PARTICULAR LIVING INDIVIDUAL, HENRY C. MILLS II (HANK), WHOSE CONSENT IS OF RECORD.

THE MARK CONSISTS OF THE SILHOUETTE OF A HUNTER HOLDING A GUN, A TARGET WITH CROSSHAIRS, AND THE WORDING "HUNTER HANK" IN A STYLIZED FORMAT.

CLASS 20—FURNITURE AND ARTICLES NOT OTHERWISE CLASSIFIED

FOR DIRECTOR'S CHAIRS; COLLAPSIBLE CHAIRS; SWIVEL STOOLS. CAMOUFLAGE STOOLS, AND HUNTING CHAIRS FOR USE IN HUNTING BLINDS AND STANDS (U.S. CLS. 2, 13, 22, 25, 32 AND 50).

FIRST USE 3-5-2010; IN COMMERCE 3-5-2010.

CLASS 28—TOYS AND SPORTING GOODS

FOR HUNTING EQUIPMENT, NAMELY, HUNTING BLINDS AND HUNTING BOW CASES (U.S. CLS. 22, 23, 38 AND 50).

FIRST USE 7-1-2010; IN COMMERCE 7-1-2010.
DAVID C. REHNER, EXAMINING ATTORNEY

SN 85-155,221. INDIANA GRANTMAKERS ALLIANCE FOUNDATION, INC., INDIANAPOLIS, IN. FILED 10-18-2010.



NO CLAIM IS MADE TO THE EXCLUSIVE RIGHT TO USE "GIVING CIRCLE", APART FROM THE MARK AS SHOWN.

THE MARK CONSISTS OF A DRAWING OF THE FACE OF A CHILD, WITH "WWW.YPIN.ORG" APPEARING BELOW THE DRAWING, ALL INSIDE OF TWO CONCENTRIC CIRCLES THAT ENCLOSE THE WORDS "PHIL'S GIVING CIRCLE TIME TALENT TREASURE" WHICH CIRCULARLY WRAP AROUND THE DRAWING.

CLASS 16—PAPER GOODS AND PRINTED MATTER

FOR ACTIVITY CARDS; PLEDGE CARDS; BOOKMARKS; STICKERS; BOOKLETS IN THE FIELD OF CHARITABLE GIVING AND PHILANTHROPY (U.S. CLS. 2, 5, 22, 23, 29, 37, 38 AND 50).

CLASS 35—ADVERTISING AND BUSINESS

FOR PROMOTING PUBLIC AWARENESS OF THE VALUE OF CHARITABLE GIVING AND PHILANTHROPY, AND THE VALUE OF DEVELOPING CHARITABLE GIVING AND PHILANTHROPY IN CHILDREN, INCLUDING VIA AN INTERNET WEBSITE (U.S. CLS. 100, 101 AND 102).

CLASS 41—EDUCATION AND ENTERTAINMENT

FOR PROVIDING TRAINING IN THE FIELD OF CHARITABLE GIVING AND PHILANTHROPY; EDUCATIONAL SERVICES, NAMELY, CONDUCTING SEMINARS AND WORKSHOPS IN THE FIELD OF CHARITABLE GIVING AND PHILANTHROPY AND DISTRIBUTION OF PRINTED MATERIALS IN CONNECTION THEREWITH IN HARD COPY OR ELECTRONIC FORMAT ON THE SAME TOPICS (U.S. CLS. 100, 101 AND 107).

MICHAEL SOUDERS, EXAMINING ATTORNEY

SN 85-155,543. DIVINE HEART CENTER LLC, DBA DIVINE HEART CENTER, WESTBOROUGH, MA. FILED 10-18-2010.

DIVINE HEART CENTER

THE MARK CONSISTS OF STANDARD CHARACTERS WITHOUT CLAIM TO ANY PARTICULAR FONT, STYLE, SIZE, OR COLOR.

NO CLAIM IS MADE TO THE EXCLUSIVE RIGHT TO USE "CENTER", APART FROM THE MARK AS SHOWN.

SN 85-157,464. UX INNOVATION LLC, SAN FRANCISCO, CA. FILED 10-20-2010.

CLASS 41—EDUCATION AND ENTERTAINMENT

FOR MEDITATION TRAINING (U.S. CLS. 100, 101 AND 107).
FIRST USE 6-3-2008; IN COMMERCE 10-1-2008.

CLASS 44—MEDICAL, BEAUTY AND AGRICULTURAL SERVICES

FOR ENERGY HEALING SERVICES, NAMELY, STRESS MANAGEMENT AND STRESS REDUCTION COUNSELING FOR INDIVIDUALS TO ENHANCE THEIR LIVES; ENERGY HEALING SERVICES, NAMELY, THERAPEUTIC TOUCH SERVICES; PROVIDING A WEBSITE FEATURING INFORMATION CONCERNING ALTERNATIVE HEALTH AND HEALING; PROVIDING BOTH IN-PERSON AND ON-LINE VIBRATIONAL ENERGY HEALING SERVICES; PROVIDING IN-PERSON ENERGY HEALING SERVICES; PROVIDING IN-PERSON VIBRATIONAL ENERGY HEALING SERVICES; PROVIDING LONG-DISTANCE ENERGY HEALING SERVICES (U.S. CLS. 100 AND 101).
FIRST USE 6-3-2008; IN COMMERCE 10-1-2008.
DAVID HOFFMAN, EXAMINING ATTORNEY

SN 85-157,346. MATHEW A. MCPHERSON, NORWALK, WI. FILED 10-20-2010.

LOST SURREAL CAMO

THE MARK CONSISTS OF STANDARD CHARACTERS WITHOUT CLAIM TO ANY PARTICULAR FONT, STYLE, SIZE, OR COLOR.

OWNER OF U.S. REG. NO. 3,828,655.

NO CLAIM IS MADE TO THE EXCLUSIVE RIGHT TO USE "CAMO", APART FROM THE MARK AS SHOWN.

CLASS 25—CLOTHING

FOR HUNTING CLOTHING, NAMELY, HATS, PANTS, SHIRTS, SWEATSHIRTS AND JACKETS (U.S. CLS. 22 AND 39).

CLASS 28—TOYS AND SPORTING GOODS

FOR ARCHERY EQUIPMENT, NAMELY, ARCHERY BOWS AND ACCESSORIES, NAMELY ARCHERY QUIVERS AND ARCHERY ARROW RESTS (U.S. CLS. 22, 23, 38 AND 50).
MELISSA VALLILLO, EXAMINING ATTORNEY

UX Innovation

THE MARK CONSISTS OF STANDARD CHARACTERS WITHOUT CLAIM TO ANY PARTICULAR FONT, STYLE, SIZE, OR COLOR.

NO CLAIM IS MADE TO THE EXCLUSIVE RIGHT TO USE "UX", APART FROM THE MARK AS SHOWN.

CLASS 35—ADVERTISING AND BUSINESS

FOR MARKET RESEARCH; MARKET SEGMENTATION CONSULTATION IN THE FIELD OF DESIGN AND DEVELOPMENT OF COMPUTER SOFTWARE AND HARDWARE (U.S. CLS. 100, 101 AND 102).
FIRST USE 11-4-2009; IN COMMERCE 11-4-2009.

CLASS 42—SCIENTIFIC AND COMPUTER SERVICES

FOR CONSULTING SERVICES FOR OTHERS IN THE FIELD OF DESIGN, PLANNING, AND IMPLEMENTATION PROJECT MANAGEMENT OF HIGH TECHNOLOGY PRODUCTS, NAMELY, COMPUTER SOFTWARE AND HARDWARE (U.S. CLS. 100 AND 101).
FIRST USE 11-4-2009; IN COMMERCE 11-4-2009.

ROBERT C. CLARK JR., EXAMINING ATTORNEY

SN 85-157,522. MASERGY COMMUNICATIONS, INC., PLANO, TX. FILED 10-20-2010.



OWNER OF U.S. REG. NOS. 2,735,575 AND 3,019,631.

THE MARK CONSISTS OF TWO QUADRILATERALS WITH ONE OR MORE CURVED SIDES NEXT TO THE WORDING "MASERGY".

CLASS 38—COMMUNICATION

FOR PROVIDING TELECOMMUNICATIONS NETWORK SERVICES, NAMELY, PROVIDING ACCESS TO AND ACROSS TELECOMMUNICATION NETWORKS; PROVIDING VIDEO, VOICE AND DATA TRANSMISSION SERVICES BY MEANS OF TELECOMMUNICATIONS NETWORKS, WIRELESS COMMUNICATION NETWORKS, AND THE INTERNET (U.S. CLS. 100, 101 AND 104).

FIRST USE 10-16-2010; IN COMMERCE 10-16-2010.

CLASS 42—SCIENTIFIC AND COMPUTER SERVICES

FOR COMPUTER MANAGEMENT SERVICES, NAMELY, THE MONITORING, REPORTING AND MANAGEMENT OF VIDEO, VOICE AND DATA TRAFFIC ACROSS THE TELECOMMUNICATIONS NETWORKS, WIRELESS COMMUNICATIONS NETWORKS, AND THE INTERNET; REMOTE AND ON-SITE MANAGEMENT OF THE INFORMATION TECHNOLOGY NETWORK SYSTEMS OF OTHERS; DESIGNING COMPUTER NETWORKS FOR OTHERS; COMPUTER CONSULTATION, NAMELY, ENHANCEMENT OF NETWORKS FOR OTHERS (U.S. CLS. 100 AND 101).
FIRST USE 10-16-2010; IN COMMERCE 10-16-2010.

REGINA DRUMMOND, EXAMINING ATTORNEY

SN 85-157,526. MASERGY COMMUNICATIONS, INC., PLANO, TX. FILED 10-20-2010.



THE MARK CONSISTS OF TWO QUADRILATERALS WITH ONE OR MORE CURVED SIDES.

CLASS 38—COMMUNICATION

FOR PROVIDING TELECOMMUNICATIONS NETWORK SERVICES, NAMELY, PROVIDING ACCESS TO AND ACROSS TELECOMMUNICATION NETWORKS; PROVIDING VIDEO, VOICE AND DATA TRANSMISSION SERVICES BY MEANS OF TELECOMMUNICATIONS NETWORKS, WIRELESS COMMUNICATION NETWORKS, AND THE INTERNET (U.S. CLS. 100, 101 AND 104).

FIRST USE 10-16-2010; IN COMMERCE 10-16-2010.

CLASS 42—SCIENTIFIC AND COMPUTER SERVICES

FOR COMPUTER MANAGEMENT SERVICES, NAMELY, THE MONITORING, REPORTING AND MANAGEMENT OF VIDEO, VOICE AND DATA TRAFFIC ACROSS THE TELECOMMUNICATIONS NETWORKS, WIRELESS COMMUNICATIONS NETWORKS, AND THE INTERNET; REMOTE AND ON-SITE MANAGEMENT OF THE INFORMATION TECHNOLOGY NETWORK SYSTEMS OF OTHERS; DESIGNING COMPUTER NETWORKS FOR OTHERS; COMPUTER CONSULTATION, NAMELY, ENHANCEMENT OF NETWORKS FOR OTHERS (U.S. CLS. 100 AND 101).

FIRST USE 10-16-2010; IN COMMERCE 10-16-2010.
REGINA DRUMMOND, EXAMINING ATTORNEY

SN 85-157,662. CANCERLINK ONTARIO INC., TORONTO, ONTARIO, CANADA, FILED 10-21-2010.



NO CLAIM IS MADE TO THE EXCLUSIVE RIGHT TO USE "ONCOLOGYEDUCATION.COM", APART FROM THE MARK AS SHOWN.

THE MARK CONSISTS OF THE WORDS "ONCOLOGYEDUCATION.COM IMPROVING PATIENT CARE THROUGH EDUCATION" UNDERNEATH A STYLIZED "O" AND "E".

CLASS 41—EDUCATION AND ENTERTAINMENT

FOR EDUCATIONAL SERVICES, NAMELY, PROVIDING CLASSES, SEMINARS AND WORKSHOPS IN THE FIELD OF THE PREVENTION AND TREATMENT OF CANCER; PROVIDING ON-LINE PUBLICATIONS IN THE NATURE OF ARTICLES, NEWSLETTERS AND GUIDELINES IN THE FIELD OF PREVENTION AND TREATMENT OF CANCER (U.S. CLS. 100, 101 AND 107).

CLASS 44—MEDICAL, BEAUTY AND AGRICULTURAL SERVICES

FOR OPERATING A WEBSITE PROVIDING ARTICLES, NEWSLETTERS, GUIDELINES AND INFORMATION IN THE AREA OF THE PREVENTION AND TREATMENT OF CANCER (U.S. CLS. 100 AND 101).

PRISCILLA MILTON, EXAMINING ATTORNEY

SN 85-159,078. S. V. B. ASSOCIATES, INC., DBA SECURITY SYSTEMS OF AMERICA, PITTSBURGH, PA. FILED 10-22-2010.

SSA

THE MARK CONSISTS OF STANDARD CHARACTERS WITHOUT CLAIM TO ANY PARTICULAR FONT, STYLE, SIZE, OR COLOR.

CLASS 37—CONSTRUCTION AND REPAIR

FOR INSTALLATION OF SECURITY, FIRE ALARM, CCTV, AND ACCESS SYSTEMS (U.S. CLS. 100, 103 AND 106).

FIRST USE 0-0-1995; IN COMMERCE 0-0-1995.

CLASS 45—PERSONAL AND LEGAL SERVICES

FOR EMERGENCY RESPONSE ALARM MONITORING SERVICES, NAMELY, MONITORING OF ALERT DEVICES BY A REMOTE MONITORING CENTER FOR THE DISPATCH OF EMERGENCY PUBLIC HEALTH AND SECURITY SERVICES AND NOTIFICATION TO THIRD PARTIES (U.S. CLS. 100 AND 101).

FIRST USE 0-0-1995; IN COMMERCE 0-0-1995.
LESLEY LAMOTHE, EXAMINING ATTORNEY

SN 85-160,112. CALZONI S.R.L., CALDERARA DI RENO (BO), ITALY, FILED 10-25-2010.



PRIORITY CLAIMED UNDER SEC. 44(D) ON ITALY APPLICATION NO. BO2010C00144, FILED 10-22-2010, REG. NO. 009467218, DATED 4-1-2011, EXPIRES 10-22-2020.

OWNER OF U.S. REG. NO. 2,956,925.

THE MARK CONSISTS OF THE LETTERS "E.UMM" TOGETHER WITH THE SILHOUETTE OF THE TOP OF A SUBMARINE BENEATH IT AND THE TOP MAST RUNNING THROUGH THE LETTER "U".

CLASS 7—MACHINERY

FOR MOTORS AND ENGINES, NAMELY, ELECTRIC AND HYDRAULIC MOTORS FOR MACHINES AND ENGINES NOT FOR LAND VEHICLES; MACHINE COUPLING AND TRANSMISSION COMPONENTS, NAMELY, COUPLINGS FOR MACHINES, SHAFT COUPLINGS FOR MACHINES, SHAFT COUPLINGS NOT FOR LAND VEHICLES, BEARINGS FOR TRANSMISSION SHAFTS BEING PARTS OF MACHINES, BELTS FOR TRANSMISSIONS OTHER THAN FOR LAND VEHICLES, POWER TRANSMISSION BELTS FOR MACHINES, AND TRANSMISSION GEARS FOR MACHINES (U.S. CLS. 13, 19, 21, 23, 31, 34 AND 35).

CLASS 12—VEHICLES

FOR APPARATUS FOR LOCOMOTION BY WATER, NAMELY, SUBMARINES AND SURFACE SHIPS; STRUCTURAL PARTS FOR SUBMARINES, NAMELY, HOISTING MASTS FOR USE WITH SENSORS AND SNORKEL EXHAUST SYSTEMS, HOISTING MASTS SOLD AS A UNIT WITH INTEGRATED SENSORS, AND HOISTING MASTS SOLD AS A UNIT WITH INTEGRATED SNORKEL EXHAUST SYSTEMS (U.S. CLS. 19, 21, 23, 31, 35 AND 44).

KIM MONINGHOFF, EXAMINING ATTORNEY

SN 85-160,316. SRIVIDYA TECH, INC., DBA MYCITYWAY, NEW YORK, NY. FILED 10-25-2010.

**CLASS 9—ELECTRICAL AND SCIENTIFIC APPARATUS**

FOR COMPUTER SOFTWARE, MOBILE DEVICE APPLICATIONS SOFTWARE, DOWNLOADABLE MOBILE DEVICE APPLICATIONS SOFTWARE, AND MOBILE DEVICE APPLICATIONS SOFTWARE DELIVERED OVER THE AIR FOR CONNECTED URBAN MOBILITY THAT ALLOW USERS TO DISCOVER, PLAN, CONNECT, EXPERIENCE AND SHARE INFORMATION ON MOBILE DEVICES ACROSS VARIOUS URBAN SETTINGS, INCLUDING DINING, SHOPPING, ENTERTAINMENT, NEWS, EVENTS, PUBLIC TRANSIT, INTERMODAL TRANSPORTATION, TRAFFIC, WEATHER, AND CIVIC DATA OR FUNCTIONALITY; SOFTWARE FOR DETECTING USERS' CURRENT LOCATION AND FILTERING SURROUNDINGS BY WEIGHING DISTANCE AGAINST RELEVANCE; SOFTWARE TO ENABLE UPLOADING, DISPLAYING, SHARING OR OTHERWISE PROVIDING ELECTRONIC MEDIA OR INFORMATION; SOFTWARE THAT ALLOWS ACTIONABILITY AFTER DISCOVERY, NAMELY, MAKING RESERVATIONS, PURCHASING EVENT TICKETS, BOOKING HOTELS; SOFTWARE TO ENABLE RECOMMENDATIONS BASED ON USER'S SOCIAL MEDIA ACTIVITY OR HISTORY, LOCATION-BASED SERVICES ACTIVITY, GENERAL INTERESTS, CURRENT LOCATION, TIMING, CURRENT SITUATION AND EXTERNAL FACTORS AND SITUATIONAL AWARENESS DURING TRAVEL; SOFTWARE FEATURING TRAVEL INFORMATION SYSTEMS FOR THE PROVISION OR RENDERING OF TRAVEL ADVICE AND INFORMATION REGARDING TRAVEL AND TRANSPORT; NAVIGATION SYSTEMS; SOFTWARE FEATURING USER GENERATED CONTENT, PLANNING, SCHEDULING, AND ALERTS FOR PERSONAL TRAVEL PLANNING; TELEPHONE-BASED INFORMATION RETRIEVAL SOFTWARE; SOFTWARE FOR ACCESS TO COMMUNICATIONS NETWORKS, NAMELY, THE INTERNET; MOBILE COMPUTING AND OPERATING PLATFORMS CONSISTING OF MOBILE APPLICATIONS FOR ALLOWING OTHERS TO PURCHASE A VARIETY OF GOODS OR SERVICES FROM THIRD PARTIES ELECTRONICALLY; ALL THE AFOREMENTIONED GOODS

FOR USE ON MOBILE DEVICES, THROUGH THE INTERNET OR THROUGH OTHER COMMUNICATIONS NETWORKS (U.S. CLS. 21, 23, 26, 36 AND 38).

FIRST USE 12-0-2009; IN COMMERCE 12-0-2009.

CLASS 35—ADVERTISING AND BUSINESS

FOR ONLINE RETAIL STORE SERVICES FEATURING MOBILE APPLICATIONS; ADVERTISING AND MARKETING SERVICES; SALES PROMOTION SERVICES FOR THIRD PARTIES; PROVIDING AN INTERNET WEBSITE PORTAL FEATURING PROMOTION AND ADVERTISING IN THE FIELDS OF SHOPPING, DINING AND RETAIL INFORMATION; PROMOTING THE GOODS AND SERVICES OF OTHERS BY PROVIDING A WEBSITE FEATURING SHOPPING, DINING AND RETAIL INFORMATION, AND PROVIDING CONSUMER INFORMATION SERVICES AND MAKING REFERRALS IN THE FIELD OF ENTERTAINMENT SERVICES FOR PRODUCTS, SERVICES, EVENTS, ACTIVITIES, FACILITIES AND LOCATIONS; ADVICE ON THE ANALYSIS OF CONSUMER BUYING HABITS AND NEEDS PROVIDED WITH THE HELP OF SENSORY, QUALITY AND QUANTITY-RELATED DATA; ALL OF THE AFOREMENTIONED SERVICES PROVIDED VIA COMMUNICATIONS NETWORKS, MOBILE TELEPHONES OR WIRELESS COMMUNICATION DEVICES (U.S. CLS. 100, 101 AND 102).

FIRST USE 12-0-2009; IN COMMERCE 12-0-2009.

CLASS 38—COMMUNICATION

FOR ELECTRONIC TRANSMISSION OF DATA AND DOCUMENTATION VIA THE INTERNET OR OTHER DATABASES; PROVISION OF TELECOMMUNICATIONS CONNECTIONS TO THE INTERNET OR COMPUTER DATABASES; PROVIDING ELECTRONIC TELECOMMUNICATIONS CONNECTIONS AND ACCESS TO ELECTRONIC COMMUNICATIONS NETWORKS, FOR TRANSMISSION OR RECEPTION OF URBAN INFORMATION; TRANSMISSION OF ELECTRONIC MEDIA, NAMELY, USER-GENERATED CONTENT; ALL OF THE AFOREMENTIONED SERVICES PROVIDED VIA COMMUNICATIONS NETWORKS, MOBILE TELEPHONES OR WIRELESS COMMUNICATION DEVICES (U.S. CLS. 100, 101 AND 104).

FIRST USE 12-0-2009; IN COMMERCE 12-0-2009.

CLASS 39—TRANSPORTATION AND STORAGE

FOR PROVIDING ENTERTAINMENT INFORMATION AND RECOMMENDATIONS BASED ON USER'S SOCIAL MEDIA ACTIVITY OR HISTORY, LOCATION-BASED SERVICES ACTIVITY, GENERAL INTERESTS, CURRENT LOCATION, TIMING, CURRENT SITUATION AND EXTERNAL FACTORS, AND PROVIDING SITUATIONAL AWARENESS DURING TRAVEL; ALL OF THE AFOREMENTIONED SERVICES PROVIDED VIA COMMUNICATIONS NETWORKS, MOBILE TELEPHONES OR WIRELESS COMMUNICATION DEVICES (U.S. CLS. 100 AND 105).

FIRST USE 12-0-2009; IN COMMERCE 12-0-2009.

CLASS 41—EDUCATION AND ENTERTAINMENT

FOR PROVIDING ENTERTAINMENT INFORMATION AND RECOMMENDATIONS BASED ON USER'S SOCIAL MEDIA ACTIVITY OR HISTORY, LOCATION-BASED SERVICES ACTIVITY, GENERAL INTERESTS, CURRENT LOCATION, TIMING, CURRENT SITUATION AND EXTERNAL FACTORS, AND PROVIDING SITUATIONAL AWARENESS DURING TRAVEL; ALL OF THE AFOREMENTIONED SERVICES PROVIDED VIA COMMUNICATIONS NETWORKS, MOBILE TELEPHONES OR WIRELESS COMMUNICATION DEVICES (U.S. CLS. 100, 101 AND 107).

FIRST USE 12-0-2009; IN COMMERCE 12-0-2009.

CLASS 42—SCIENTIFIC AND COMPUTER SERVICES

FOR COMPUTER SERVICES, NAMELY, CREATING INDEXES OF INFORMATION, SITES AND OTHER RESOURCES AVAILABLE ON GLOBAL COMPUTER NETWORKS FOR OTHERS; PROVIDING WEATHER INFORMATION; NON-DOWNLOADABLE SOFTWARE FOR DETECTING USERS' CURRENT LOCATION AND FILTERING SURROUNDINGS BY WEIGHING DISTANCE AGAINST RELEVANCE, AND ALLOWING USERS TO DISCOVER, PLAN, CONNECT, EXPERIENCE, SEARCH, SHARE, AND SORT LOCAL INFORMATION ON MOBILE DEVICES ACROSS VARIOUS URBAN SETTINGS; ALL OF THE AFOREMENTIONED SERVICES PROVIDED VIA COMMUNICATIONS NETWORKS, MOBILE TELEPHONES OR WIRELESS COMMUNICATION DEVICES (U.S. CLS. 100 AND 101).

FIRST USE 12-0-2009; IN COMMERCE 12-0-2009.
 NAAKWAMA ANKRAH, EXAMINING ATTORNEY

SN 85-160,353. SRIVIDYA TECH, INC., DBA MYCITYWAY,
 NEW YORK, NY. FILED 10-25-2010.

MYCITYWAY

THE MARK CONSISTS OF STANDARD CHARACTERS WITHOUT CLAIM TO ANY PARTICULAR FONT, STYLE, SIZE, OR COLOR.

CLASS 9—ELECTRICAL AND SCIENTIFIC APPARATUS

FOR COMPUTER SOFTWARE, MOBILE DEVICE APPLICATIONS SOFTWARE, DOWNLOADABLE MOBILE DEVICE APPLICATIONS SOFTWARE, AND MOBILE DEVICE APPLICATIONS SOFTWARE DELIVERED OVER THE AIR FOR CONNECTED URBAN MOBILITY THAT ALLOW USERS TO DISCOVER, PLAN, CONNECT, EXPERIENCE AND SHARE INFORMATION ON MOBILE DEVICES ACROSS VARIOUS URBAN SETTINGS, INCLUDING DINING, SHOPPING, ENTERTAINMENT, NEWS, EVENTS, PUBLIC TRANSIT, INTERMODAL TRANSPORTATION, TRAFFIC, WEATHER, AND CIVIC DATA OR FUNCTIONALITY; SOFTWARE FOR DETECTING USERS' CURRENT LOCATION AND FILTERING SURROUNDINGS BY WEIGHING DISTANCE AGAINST RELEVANCE; SOFTWARE TO ENABLE UPLOADING, DISPLAYING, SHARING OR OTHERWISE PROVIDING ELECTRONIC MEDIA OR INFORMATION; SOFTWARE THAT ALLOWS ACTIONABILITY AFTER DISCOVERY, NAMELY, MAKING RESERVATIONS, PURCHASING EVENT TICKETS, BOOKING HOTELS; SOFTWARE TO ENABLE RECOMMENDATIONS BASED ON USER'S SOCIAL MEDIA ACTIVITY OR HISTORY, LOCATION-BASED SERVICES ACTIVITY, GENERAL INTERESTS, CURRENT LOCATION, TIMING, CURRENT SITUATION AND EXTERNAL FACTORS AND SITUATIONAL AWARENESS DURING TRAVEL; SOFTWARE FEATURING TRAVEL INFORMATION SYSTEMS FOR THE PROVISION OR RENDERING OF TRAVEL ADVICE AND INFORMATION REGARDING TRAVEL AND TRANSPORT; NAVIGATION SYSTEMS; SOFTWARE FEATURING USER GENERATED CONTENT, PLANNING, SCHEDULING, AND ALERTS FOR PERSONAL TRAVEL PLANNING; TELEPHONE-BASED INFORMATION RETRIEVAL SOFTWARE; SOFTWARE FOR ACCESS TO COMMUNICATIONS NETWORKS, NAMELY, THE INTERNET; MOBILE COMPUTING AND OPERATING PLATFORMS CONSISTING OF MOBILE APPLICATIONS FOR ALLOWING OTHERS TO PURCHASE A VARIETY OF GOODS OR SERVICES FROM THIRD PARTIES ELECTRONICALLY; ALL THE AFOREMENTIONED GOODS

FOR USE ON MOBILE DEVICES, THROUGH THE INTERNET OR THROUGH OTHER COMMUNICATIONS NETWORKS (U.S. CLS. 21, 23, 26, 36 AND 38).

FIRST USE 12-0-2009; IN COMMERCE 12-0-2009.

CLASS 35—ADVERTISING AND BUSINESS

FOR ONLINE RETAIL STORE SERVICES FEATURING MOBILE APPLICATIONS; ADVERTISING AND MARKETING SERVICES; SALES PROMOTION SERVICES FOR THIRD PARTIES; PROVIDING AN INTERNET WEBSITE PORTAL FEATURING PROMOTION AND ADVERTISING IN THE FIELDS OF SHOPPING, DINING AND RETAIL INFORMATION; PROMOTING THE GOODS AND SERVICES OF OTHERS BY PROVIDING A WEBSITE FEATURING SHOPPING, DINING AND RETAIL INFORMATION, AND PROVIDING CONSUMER INFORMATION SERVICES AND MAKING REFERRALS IN THE FIELD OF ENTERTAINMENT SERVICES FOR PRODUCTS, SERVICES, EVENTS, ACTIVITIES, FACILITIES AND LOCATIONS; ADVICE ON THE ANALYSIS OF CONSUMER BUYING HABITS AND NEEDS PROVIDED WITH THE HELP OF SENSORY, QUALITY AND QUANTITY-RELATED DATA; ALL OF THE AFOREMENTIONED SERVICES PROVIDED VIA COMMUNICATIONS NETWORKS, MOBILE TELEPHONES OR WIRELESS COMMUNICATION DEVICES (U.S. CLS. 100, 101 AND 102).

FIRST USE 12-0-2009; IN COMMERCE 12-0-2009.

CLASS 38—COMMUNICATION

FOR ELECTRONIC TRANSMISSION OF DATA AND DOCUMENTATION VIA THE INTERNET OR OTHER DATABASES; PROVISION OF TELECOMMUNICATIONS CONNECTIONS TO THE INTERNET OR COMPUTER DATABASES; PROVIDING ELECTRONIC TELECOMMUNICATIONS CONNECTIONS AND ACCESS TO ELECTRONIC COMMUNICATIONS NETWORKS, FOR TRANSMISSION OR RECEPTION OF URBAN INFORMATION; TRANSMISSION OF ELECTRONIC MEDIA, NAMELY, USER-GENERATED CONTENT; ALL OF THE AFOREMENTIONED SERVICES PROVIDED VIA COMMUNICATIONS NETWORKS, MOBILE TELEPHONES OR WIRELESS COMMUNICATION DEVICES (U.S. CLS. 100, 101 AND 104).

FIRST USE 12-0-2009; IN COMMERCE 12-0-2009.

CLASS 39—TRANSPORTATION AND STORAGE

FOR TRAVEL GUIDES AND TRAVEL INFORMATION SERVICES; GPS NAVIGATION SERVICES; PUBLISHING OF TRAVEL GUIDE BOOKS AND TOUR BOOKS; TRAVEL INFORMATION SERVICES, NAMELY, PROVIDING A WEBSITE FEATURING TRAVEL, PUBLIC TRANSIT, INTERMODAL TRANSPORTATION, ROAD AND TRAFFIC INFORMATION; ALL OF THE AFOREMENTIONED SERVICES PROVIDED VIA COMMUNICATIONS NETWORKS, MOBILE TELEPHONES OR WIRELESS COMMUNICATION DEVICES (U.S. CLS. 100 AND 105).

FIRST USE 12-0-2009; IN COMMERCE 12-0-2009.

CLASS 41—EDUCATION AND ENTERTAINMENT

FOR PROVIDING ENTERTAINMENT INFORMATION AND RECOMMENDATIONS BASED ON USER'S SOCIAL MEDIA ACTIVITY OR HISTORY, LOCATION-BASED SERVICES ACTIVITY, GENERAL INTERESTS, CURRENT LOCATION, TIMING, CURRENT SITUATION AND EXTERNAL FACTORS, AND PROVIDING SITUATIONAL AWARENESS DURING TRAVEL; ALL OF THE AFOREMENTIONED SERVICES PROVIDED VIA COMMUNICATIONS NETWORKS, MOBILE TELEPHONES OR WIRELESS COMMUNICATION DEVICES (U.S. CLS. 100, 101 AND 107).

FIRST USE 12-0-2009; IN COMMERCE 12-0-2009.

CLASS 42—SCIENTIFIC AND COMPUTER SERVICES

FOR COMPUTER SERVICES, NAMELY, CREATING INDEXES OF INFORMATION, SITES AND OTHER RESOURCES AVAILABLE ON GLOBAL COMPUTER NETWORKS FOR OTHERS; PROVIDING WEATHER INFORMATION; NON-DOWNLOADABLE SOFTWARE FOR DETECTING USERS' CURRENT LOCATION AND FILTERING SURROUNDINGS BY WEIGHING DISTANCE AGAINST RELEVANCE, AND ALLOWING USERS TO DISCOVER, PLAN, CONNECT, EXPERIENCE, SEARCH, SHARE, AND SORT LOCAL INFORMATION ON MOBILE DEVICES ACROSS VARIOUS URBAN SETTINGS; ALL OF THE AFOREMENTIONED SERVICES PROVIDED VIA COMMUNICATIONS NETWORKS, MOBILE TELEPHONES OR WIRELESS COMMUNICATION DEVICES (U.S. CLS. 100 AND 101).

FIRST USE 12-0-2009; IN COMMERCE 12-0-2009.
 NAAKWAMA ANKRAH, EXAMINING ATTORNEY

SN 85-160,704. VICTORIA L. WESTRA, DBA ART FOR AUTISM, TAMPA, FL. FILED 10-25-2010.

Art for Autism

THE MARK CONSISTS OF STANDARD CHARACTERS WITHOUT CLAIM TO ANY PARTICULAR FONT, STYLE, SIZE, OR COLOR.

NO CLAIM IS MADE TO THE EXCLUSIVE RIGHT TO USE "AUTISM", APART FROM THE MARK AS SHOWN.

CLASS 43—HOTEL AND RESTAURANT SERVICES

FOR COFFEE AND TEA BARS; COFFEE SHOPS; COFFEE SUPPLY SERVICES FOR OFFICES; COFFEE-HOUSE AND SNACK-BAR SERVICES (U.S. CLS. 100 AND 101).

FIRST USE 7-1-2007; IN COMMERCE 7-1-2007.

CLASS 44—MEDICAL, BEAUTY AND AGRICULTURAL SERVICES

FOR COGNITIVE THERAPY SERVICES; PROVIDING AN INTERNET WEBSITE FEATURING NEWS AND INFORMATION RELATING TO DIAGNOSIS AND TREATMENT OF AUTISM (U.S. CLS. 100 AND 101).

FIRST USE 7-1-2007; IN COMMERCE 7-1-2007.
 IRA J. GOODSAD, EXAMINING ATTORNEY

SN 85-161,626. PATRICK J. NOONAN, CASTLETROY, LIMERICK, IRELAND, FILED 10-26-2010.

Fashion2Model

THE MARK CONSISTS OF STANDARD CHARACTERS WITHOUT CLAIM TO ANY PARTICULAR FONT, STYLE, SIZE, OR COLOR.

PRIORITY CLAIMED UNDER SEC. 44(D) ON ERPNCMNTY TM OFC APPLICATION NO. 009082322, FILED 5-5-2010, REG. NO. 009082322, DATED 12-6-2010, EXPIRES 5-5-2020.

CLASS 35—ADVERTISING AND BUSINESS

FOR ADVERTISING SERVICES; BUSINESS MANAGEMENT; BUSINESS ADMINISTRATION; PROVIDING OFFICE FUNCTIONS; COMPILATION OF INFORMATION INTO ONLINE COMPUTER DATABASES AND SEARCHABLE ONLINE COMPUTER DATABASES; COMPILATION OF INFORMATION INTO ONLINE COMPUTER DATABASES AND SEARCHABLE ONLINE COMPUTER DATABASES ALL FOR ALLOWING THE USER TO COMPARE VARIOUS GOODS AND SERVICES; ORGANIZATION OF BUSINESS COMPETITIONS, INCLUDING ONLINE BUSINESS COMPETITIONS (U.S. CLS. 100, 101 AND 102).

CLASS 38—COMMUNICATION

FOR PROVISION OF ACCESS TO ELECTRONIC SITES FEATURING BLOGS IN THE FIELD OF FASHION, BEAUTY, CLOTHING, AND FASHION AND BEAUTY ACCESSORIES; TELECOMMUNICATIONS SERVICES FOR PROVIDING ACCESS TO COMPUTER DATABASES; TELECOMMUNICATION SERVICES, NAMELY, THE PROVISION OF ONLINE FORUMS FOR THE TRANSMISSION OF MESSAGES AMONG COMPUTER USERS, THE PROVISION OF INTERNET CHAT ROOMS, AND THE PROVISION OF ONLINE CHAT ROOMS FOR SOCIAL NETWORKING; PROVISION OF ACCESS TO ONLINE COMPUTER DATABASES AND SEARCHABLE ONLINE COMPUTER DATABASES; TELECOMMUNICATIONS SERVICES FOR PROVIDING ACCESS TO SEARCHABLE COMPUTER DATABASES; PROVISION OF ACCESS TO ONLINE COMPUTER DATABASES AND SEARCHABLE ONLINE COMPUTER DATABASES; PROVISION OF TELEPHONE DIRECTORY SERVICES, NAMELY, TELEPHONE CALL COMPLETION SERVICES FOR DIRECTORY ASSISTANCE CUSTOMERS (U.S. CLS. 100, 101 AND 104).

CLASS 41—EDUCATION AND ENTERTAINMENT

FOR ENTERTAINMENT IN THE NATURE OF COMPETITIONS IN THE FIELD OF FASHION, BEAUTY, CLOTHING, AND FASHION AND BEAUTY ACCESSORIES, INCLUDING ONLINE COMPETITIONS; ORGANIZATION OF CONTESTS, INCLUDING ONLINE CONTESTS; ORGANIZATION OF LOTTERIES, INCLUDING ONLINE LOTTERIES; PRODUCTION OF A GAME SHOW, INCLUDING ONLINE GAME SHOWS; ENTERTAINMENT SERVICES, NAMELY, ENTERTAINMENT IN THE NATURE OF FASHION SHOWS FEATURING FASHION, BEAUTY, CLOTHING, AND FASHION AND BEAUTY ACCESSORIES; CULTURAL ACTIVITIES, NAMELY, ORGANIZATION OF SHOWS IN THE FIELD OF FASHION, BEAUTY, CLOTHING, AND FASHION AND BEAUTY ACCESSORIES (U.S. CLS. 100, 101 AND 107).

CLASS 45—PERSONAL AND LEGAL SERVICES

FOR PROVISION OF INFORMATION AND ONLINE INFORMATION AND DATABASES ALLOWING CUSTOMERS TO MAKE COMPARISONS AND TO CHOOSE BETWEEN DIFFERENT FASHIONS, CLOTHING STYLES, CLOTHING, FASHION ACCESSORIES; FASHION AND PERSONAL STYLING SERVICES, NAMELY, PROVIDING FASHION INFORMATION AND EVALUATING THE PHYSICAL ATTRIBUTES, LIFESTYLE, AND FASHION STYLES OF OTHERS AND RECOMMENDING CLOTHING AND ACCESSORIES TO ACHIEVE THE PERSONAL IMAGE DESIRED BY THE CLIENT; PROVISION OF CONSULTANCY SERVICES RELATING TO FASHION AND PERSONAL STYLING TO ACHIEVE A DESIRED PERSONAL IMAGE; PROVISION OF INFORMATION RELATING TO FASHION AND PERSONAL STYLING TO ACHIEVE A DESIRED PERSONAL IMAGE; PROVISION OF ONLINE INFORMATION AND DATABASES RELATING TO FASHION INFORMATION AND PERSONAL STYLING TO ACHIEVE A DESIRED PERSONAL IMAGE; PROVISION OF ONLINE SEARCHABLE DATABASES RELATING TO FASHION INFORMATION AND PERSONAL STYLING TO ACHIEVE A DESIRED PERSONAL IMAGE (U.S. CLS. 100 AND 101).

MARY CRAWFORD, EXAMINING ATTORNEY

SN 85-163,057. AUTO-GRAPHICS, INC., POMONA, CA.
FILED 10-27-2010.



AGent **VERSO**

SN 85-161,883. AVERY DENNISON CORPORATION, PASADENA, CA. FILED 10-26-2010.

SMARTFACE

THE MARK CONSISTS OF A STYLIZED LETTER "V" WITHIN A CIRCLE ADJACENT TO WORDS "AGENT VERSO" WHERE "AG" AND "VERSO" ARE CAPITALIZED. THE COLORS BLACK, WHITE AND/OR GRAY REPRESENT BACKGROUND, OUTLINING, SHADING AND/OR TRANSPARENT AREAS AND ARE NOT PART OF THE MARK.

CLASS 9—ELECTRICAL AND SCIENTIFIC APPARATUS

FOR DOWNLOADABLE LIBRARY MANAGEMENT SOFTWARE (U.S. CLS. 21, 23, 26, 36 AND 38).
FIRST USE 11-13-2009; IN COMMERCE 1-15-2010.

CLASS 42—SCIENTIFIC AND COMPUTER SERVICES

FOR NONDOWNLOADABLE LIBRARY MANAGEMENT SOFTWARE (U.S. CLS. 100 AND 101).
FIRST USE 1-15-2010; IN COMMERCE 1-15-2010.
MARILYN IZZI, EXAMINING ATTORNEY

THE MARK CONSISTS OF STANDARD CHARACTERS WITHOUT CLAIM TO ANY PARTICULAR FONT, STYLE, SIZE, OR COLOR.

CLASS 9—ELECTRICAL AND SCIENTIFIC APPARATUS

FOR ELECTRONIC TAGS AND DETECTORS FOR USE IN INVENTORY TRACKING AND CONTROL; RADIO FREQUENCY IDENTIFICATION (RFID) SENSORS FOR TRACKING AND CONTROL OF INVENTORY; ELECTRONICALLY ENCODED LABELS AND TAGS AND DETECTORS THAT ARE CHEMICALLY OR ELECTRONICALLY OR BIOLOGICALLY RESPONSIVE, THAT MEASURE THE FRESHNESS OF FOOD PRODUCTS; ELECTRONIC SECURITY LABELS, NAMELY, LABELS CARRYING ENCODED IDENTIFICATION INFORMATION; ELECTRONIC TAGS FOR USE IN INVENTORY TRACKING AND CONTROL; LABELS WITH BUILT-IN INDICATORS IN THE NATURE OF LABELS CARRYING MAGNETICALLY, OPTICALLY, OR ELECTRONICALLY RECORDED OR ENCODED INFORMATION; NON-MAGNETIC PAPER LABELS THAT ARE ELECTRONICALLY RESPONSIVE FOR TRACKING AND CONTROL OF INVENTORY; PAPER LABELS AND TAGS THAT ARE ELECTRONICALLY RESPONSIVE TO RADIO FREQUENCIES BY MEANS OF AN ANTENNA FOR USE IN THE TRACKING AND CONTROL OF INVENTORY; AND ANTI-COUNTERFEITING AND SECURITY LABELS CARRYING MAGNETICALLY, OPTICALLY, OR ELECTRONICALLY RECORDED OR ENCODED INFORMATION (U.S. CLS. 21, 23, 26, 36 AND 38).

CLASS 16—PAPER GOODS AND PRINTED MATTER

FOR PAPER LABELS AND TAGS THAT ARE CHEMICALLY OR ELECTRICALLY OR BIOLOGICALLY RESPONSIVE, THAT MEASURE THE FRESHNESS OF FOOD PRODUCTS; AND PAPER SECURITY LABELS, NAMELY, LABELS WHICH ENCODE IDENTIFICATION INFORMATION (U.S. CLS. 2, 5, 22, 23, 29, 37, 38 AND 50).
KRISTINA MORRIS, EXAMINING ATTORNEY

SN 85-163,076. AUTO-GRAPHICS, INC., POMONA, CA.
FILED 10-27-2010.



AGent **Iluminar**

THE MARK CONSISTS OF LOWER CASE "I" WITHIN A SHADED CIRCLE ADJACENT TO WORDS "AGENT ILUMINAR" WITH "AG" LETTERS CAPITALIZED. THE COLORS BLACK, WHITE AND/OR GRAY REPRESENT BACKGROUND, OUTLINING, SHADING AND/OR TRANSPARENT AREAS AND ARE NOT PART OF THE MARK.

CLASS 9—ELECTRICAL AND SCIENTIFIC APPARATUS

FOR NONDOWNLOADABLE SOFTWARE FOR CONNECTING WITH INTERNET BASED LIBRARY MANAGEMENT SOFTWARE (U.S. CLS. 21, 23, 26, 36 AND 38).
FIRST USE 11-13-2009; IN COMMERCE 1-15-2010.

CLASS 42—SCIENTIFIC AND COMPUTER SERVICES

FOR NONDOWNLOADABLE SOFTWARE FOR CONNECTING WITH INTERNET BASED LIBRARY MANAGEMENT SOFTWARE (U.S. CLS. 100 AND 101).
FIRST USE 1-15-2010; IN COMMERCE 1-15-2010.
MARILYN IZZI, EXAMINING ATTORNEY

SN 85-163,087. AUTO-GRAPHICS, INC., POMONA, CA.
FILED 10-27-2010.



NO CLAIM IS MADE TO THE EXCLUSIVE RIGHT TO USE "RESOURCE SHARING", APART FROM THE MARK AS SHOWN.

THE COLOR(S) BLACK, WHITE AND GRAY IS/ARE CLAIMED AS A FEATURE OF THE MARK.

THE MARK CONSISTS OF LOWER CASE "RS" WITHIN A SHADED CIRCLE ADJACENT TO WORDS "AGENT RESOURCE SHARING" WITH "AG" LETTERS CAPITALIZED. THE COLORS BLACK, WHITE AND/OR GRAY REPRESENT BACKGROUND, OUTLINING, SHADING AND/OR TRANSPARENT AREAS AND ARE NOT PART OF THE MARK.

CLASS 9—ELECTRICAL AND SCIENTIFIC APPARATUS

FOR DOWNLOADABLE LIBRARY MANAGEMENT SOFTWARE AND DOWNLOADABLE INTERLIBRARY LOAN SOFTWARE (U.S. CLS. 21, 23, 26, 36 AND 38).

FIRST USE 11-13-2009; IN COMMERCE 1-15-2010.

CLASS 42—SCIENTIFIC AND COMPUTER SERVICES

FOR NONDOWNLOADABLE LIBRARY MANAGEMENT SOFTWARE AND NONDOWNLOADABLE INTERLIBRARY LOAN SOFTWARE (U.S. CLS. 100 AND 101).

FIRST USE 1-15-2010; IN COMMERCE 1-15-2010.
MARILYN IZZI, EXAMINING ATTORNEY

SN 85-163,494. NATIONAL HUMAN SERVICES ASSEMBLY,
WASHINGTON, DC. FILED 10-28-2010.

NATIONAL COLLABORATION FOR
YOUTH

THE MARK CONSISTS OF STANDARD CHARACTERS WITHOUT CLAIM TO ANY PARTICULAR FONT, STYLE, SIZE, OR COLOR.
SEC. 2(F).

CLASS 16—PAPER GOODS AND PRINTED MATTER

FOR PRINTED PUBLICATIONS, NAMELY, BROCHURES AND STUDIES IN THE NATURE OF RESEARCH REPORTS PERTAINING TO HEALTH, HUMAN SERVICES, FAMILY, YOUTHS, YOUTH DEVELOPMENT, COMMUNITY, AND SOCIAL ISSUES (U.S. CLS. 2, 5, 22, 23, 29, 37, 38 AND 50).

FIRST USE 0-0-1970; IN COMMERCE 0-0-1970.

CLASS 35—ADVERTISING AND BUSINESS

FOR ASSOCIATION SERVICES, NAMELY, PROMOTING THE INTERESTS OF ORGANIZATIONS IN THE HEALTH, HUMAN, FAMILY, YOUTH, AND COMMUNITY DEVELOPMENT FIELDS; PROVIDING INFORMATION AND RESEARCH IN THE FIELD OF GOVERNMENT AFFAIRS AND POLITICAL ISSUES AS THEY RELATE TO HEALTH, HUMAN AND COMMUNITY DEVELOPMENT, HUMAN SERVICES, FAMILIES AND YOUTH; PUBLIC POLICY RESEARCH SERVICES; GOVERNMENT RELATIONS CONSULTANCY SERVICES; LOBBYING SERVICES, NAMELY, PROMOTING THE INTERESTS OF FAMILIES AND YOUTH IN THE FIELDS OF LEGISLATION AND REGULATION; PROMOTING PUBLIC AWARENESS OF FAMILY, YOUTH, AND SOCIAL ISSUES, INDIVIDUAL AND PROFESSIONAL DEVELOPMENT AND THE IMPORTANCE OF THE NONPROFIT HEALTH AND HUMAN SERVICES (U.S. CLS. 100, 101 AND 102).

FIRST USE 0-0-1970; IN COMMERCE 0-0-1970.
JOHN GARTNER, EXAMINING ATTORNEY

SN 85-163,777. GENECELL INTERNATIONAL LLC, MIAMI,
FL. FILED 10-28-2010.



NO CLAIM IS MADE TO THE EXCLUSIVE RIGHT TO USE "INTERNATIONAL", APART FROM THE MARK AS SHOWN.

THE MARK CONSISTS OF THE WORDS "GENECCELL INTERNATIONAL" WITH THE WORD "INTERNATIONAL" APPEARING UNDER THE WORD "GENECCELL" WITH ONE LINE APPEARING UNDER THE WORD "GENECCELL" AND ANOTHER LINE APPEARING UNDER THE WORD "INTERNATIONAL". TO THE LEFT OF THE LETTER "G" IN THE WORD "GENECCELL" IS A CIRCLE COMPOSED OF FIFTEEN SMALLER CIRCLES IN THREE GROUPS OF FIVE CIRCLES OF DECREASING SIZE.

CLASS 40—MATERIAL TREATMENT

FOR CORD BLOOD PROCESSING, NAMELY, UMBILICAL CORD BLOOD PROCESSING FOR TRANSPLANT, STEM CELL CRYOPRESERVATION SERVICES; CORD BLOOD CRYOPRESERVATION SERVICES; AND TISSUE CRYOPRESERVATION SERVICES (U.S. CLS. 100, 103 AND 106).

FIRST USE 7-26-2010; IN COMMERCE 8-1-2010.

CLASS 42—SCIENTIFIC AND COMPUTER SERVICES

FOR SCIENTIFIC CELLULAR RESEARCH (U.S. CLS. 100 AND 101).

FIRST USE 7-26-2010; IN COMMERCE 8-1-2010.

CLASS 44—MEDICAL, BEAUTY AND AGRICULTURAL SERVICES

FOR ISOLATION, COLLECTION, AND BANKING OF UMBILICAL CORD TISSUE PERIVASCULAR STEM CELLS (U.S. CLS. 100 AND 101).

FIRST USE 7-26-2010; IN COMMERCE 8-1-2010.
DOMINIC FATHY, EXAMINING ATTORNEY

SN 85-164,282. EDELWISE INTERNATIONAL LLC, PISCATAWAY, NJ. FILED 10-28-2010.



NO CLAIM IS MADE TO THE EXCLUSIVE RIGHT TO USE "COOKING", APART FROM THE MARK AS SHOWN.

THE MARK CONSISTS OF THE WORDING "ECO COOKING". A DESIGN OF LEAVES IS ATTACHED TO THE LETTERS "E" AND "N" RESPECTIVELY. BELOW APPEARS A MIRROR IMAGE OF THE WORDING AND THE DESIGNS THAT FADES AS IT GETS CLOSER TO THE BOTTOM.

CLASS 8—HAND TOOLS

FOR FLATWARE, NAMELY, FORKS, KNIVES, AND SPOONS; MEAT TENDERIZER, NAMELY, A KITCHEN Mallet (U.S. CLS. 23, 28 AND 44).

FIRST USE 0-0-2008; IN COMMERCE 0-0-2009.

CLASS 21—HOUSEWARES AND GLASS

FOR CHOPPING BOARDS FOR KITCHEN USE; CHOPSTICKS; COASTERS NOT OF PAPER AND NOT BEING TABLE LINEN; COOKING SKEWERS; HOUSEHOLD UTENSILS, NAMELY, KITCHEN TONGS; NAPKIN RINGS NOT OF PRECIOUS METALS; SALT AND PEPPER SHAKERS; TOOTHPICKS; TRIVETS (U.S. CLS. 2, 13, 23, 29, 30, 33, 40 AND 50).

FIRST USE 0-0-2008; IN COMMERCE 0-0-2009.

COURTNEY ALVAREZ, EXAMINING ATTORNEY

SN 85-164,467. GRABOWSKI, SZYMON, GDYNIA, POLAND, FILED 10-29-2010.

CLICKMEETING

THE MARK CONSISTS OF STANDARD CHARACTERS WITHOUT CLAIM TO ANY PARTICULAR FONT, STYLE, SIZE, OR COLOR.

CLASS 38—COMMUNICATION

FOR TELECOMMUNICATION SERVICES, NAMELY, BROADCASTING A WIDE VARIETY OF PROGRAMS, MEETINGS, EVENTS AND REAL TIME INFORMATION OVER GLOBAL COMPUTER COMMUNICATIONS NETWORKS; AUDIO AND VIDEO TELECONFERENCING SERVICES; PROVIDING INTERNET CHAT ROOMS; STREAMING OF AUDIO, VISUAL AND AUDIOVISUAL MATERIAL VIA GLOBAL COMPUTER NETWORK (U.S. CLS. 100, 101 AND 104).

CLASS 42—SCIENTIFIC AND COMPUTER SERVICES

FOR COMPUTER SERVICES, NAMELY, HOSTING ONLINE WEB FACILITIES FOR OTHERS FOR CONDUCTING ONLINE CONFERENCES, MEETINGS, DEMONSTRATIONS, VIRTUAL TOURS, PRESENTATIONS AND INTERACTIVE DISCUSSIONS (U.S. CLS. 100 AND 101).

DAWN FELDMAN, EXAMINING ATTORNEY

SN 85-164,733. THE MCGRAW-HILL COMPANIES, INC., NEW YORK, NY. FILED 10-29-2010.

5 STEPS TO A 5

THE MARK CONSISTS OF STANDARD CHARACTERS WITHOUT CLAIM TO ANY PARTICULAR FONT, STYLE, SIZE, OR COLOR.

SEC. 2(F).

CLASS 9—ELECTRICAL AND SCIENTIFIC APPARATUS

FOR MP3 FILES RECORDED ON DISK, CD-ROMS, DOWNLOADABLE E-BOOKS, AND COMPUTER SOFTWARE CONTAINING EDUCATIONAL MATERIALS IN THE FIELDS OF BIOLOGY, CALCULUS, CHEMISTRY, FOREIGN LANGUAGES, ENGLISH, ENVIRONMENTAL SCIENCE, ECONOMICS, MICROECONOMICS, MACROECONOMICS, GEOGRAPHY, HISTORY, MATH, POLITICS, PHYSICS, PSYCHOLOGY, SCIENCE, AND STATISTICS (U.S. CLS. 21, 23, 26, 36 AND 38).

FIRST USE 0-0-2001; IN COMMERCE 0-0-2001.

CLASS 16—PAPER GOODS AND PRINTED MATTER

FOR (BASED ON USE IN COMMERCE) SERIES OF TEXTBOOKS IN THE AREAS OF SCIENCE, BIOLOGY, ENGLISH, PSYCHOLOGY, AND HISTORY; (BASED ON INTENT TO USE) SERIES OF TEXTBOOKS IN THE AREAS OF MATH, CALCULUS, ENVIRONMENTAL SCIENCE, GEOGRAPHY, ECONOMICS, MICROECONOMICS, MACROECONOMICS, PHYSICS, STATISTICS, AND POLITICS (U.S. CLS. 2, 5, 22, 23, 29, 37, 38 AND 50).

FIRST USE 0-0-2001; IN COMMERCE 0-0-2001.

KIMBERLY FRYE, EXAMINING ATTORNEY

SN 85-164,750. ABM WIRELESS, INC., DBA MOBILEISTIC, HAUPPAUGE, NY. FILED 10-29-2010.



OWNER OF U.S. REG. NOS. 2,752,217 AND 3,804,632.

THE MARK CONSISTS OF THE STYLIZED WORDING "MOBILEISTIC" IN LOWER CAPS WITH THE LETTER "M" SUBSTANTIALLY CONTAINED WITHIN A DARKER CIRCLE AND PARTIALLY FORMING THE RIGHT BORDER OF THE CIRCLE.

CLASS 9—ELECTRICAL AND SCIENTIFIC APPARATUS

FOR TELECOMMUNICATION PRODUCTS AND CELLULAR PHONE ACCESSORIES, NAMELY, WIRELESS EQUIPMENT IN THE NATURE OF CELLULAR PHONES, PORTABLE MEDIA PLAYERS, CELL PHONE BATTERY CHARGERS, BATTERIES, MEMORY CARDS, HEADSETS FOR CELL PHONES, DATA ELECTRONIC CABLES, ANTENNAS, CARRYING CASES FOR CELL PHONES, GPS NAVIGATION DEVICES, CLIPS, HOLDERS, ADAPTORS AND ACCESSORIES FOR PORTABLE MUSIC PLAYERS IN THE NATURE OF CARRYING CASES, MEDIA STORAGE DEVICES IN THE NATURE OF MEMORY CARDS AND FLASH DRIVES, HANDS FREE DEVICES AND HOLDERS THERETO, HEADSETS, EARPHONES AND DATA ELECTRONIC CABLES (U.S. CLS. 21, 23, 26, 36 AND 38).

FIRST USE 1-1-2006; IN COMMERCE 1-1-2006.

CLASS 35—ADVERTISING AND BUSINESS

FOR DISTRIBUTORSHIP SERVICES AND RETAIL STORE SERVICES IN THE FIELD OF TELEPHONE HANDSETS AND TELECOMMUNICATION PRODUCTS, CELLULAR PHONES AND CELLULAR PHONE ACCESSORIES, NAMELY, WIRELESS EQUIPMENT, CHARGERS, BATTERIES, MEMORY CARDS, HEADSETS, DATA CABLES, ANTENNAS, CASES, NAVIGATION EQUIPMENT, ADAPTORS, ACCESSORIES FOR PORTABLE MUSIC PLAYERS; RETAIL STORE SERVICES FEATURING TELECOMMUNICATIONS SERVICE PLANS AND TELECOMMUNICATIONS SERVICE ACTIVATION (U.S. CLS. 100, 101 AND 102).

FIRST USE 1-1-2006; IN COMMERCE 1-1-2006.
WILLIAM VERHOSEK, EXAMINING ATTORNEY

SN 85-164,948. GRABOWSKI, SZYMON, GDYNIA, POLAND,
FILED 10-29-2010.

CLICKWEBINAR

THE MARK CONSISTS OF STANDARD CHARACTERS WITHOUT CLAIM TO ANY PARTICULAR FONT, STYLE, SIZE, OR COLOR.

CLASS 38—COMMUNICATION

FOR STREAMING OF AUDIO, VISUAL AND AUDIO-VISUAL MATERIAL VIA A GLOBAL COMPUTER NETWORK; TELECOMMUNICATION SERVICES, NAMELY, BROADCASTING A WIDE VARIETY OF PROGRAMS, MEETINGS, EVENTS AND REAL TIME INFORMATION OVER GLOBAL COMPUTER COMMUNICATIONS NETWORKS; AUDIO AND VIDEO TELECONFERENCING SERVICES; PROVIDING INTERNET CHAT ROOMS (U.S. CLS. 100, 101 AND 104).

CLASS 42—SCIENTIFIC AND COMPUTER SERVICES

FOR COMPUTER SERVICES, NAMELY, HOSTING ONLINE WEB FACILITIES FOR OTHERS FOR CONDUCTING ONLINE CONFERENCES, MEETINGS, DEMONSTRATIONS, VIRTUAL TOURS, PRESENTATIONS AND INTERACTIVE DISCUSSIONS (U.S. CLS. 100 AND 101).

DAWN FELDMAN, EXAMINING ATTORNEY

SN 85-165,567. IGIVERECEIVE, LLC, BROOKLYN, NY.
FILED 10-30-2010.

IGiveReceive

THE MARK CONSISTS OF STANDARD CHARACTERS WITHOUT CLAIM TO ANY PARTICULAR FONT, STYLE, SIZE, OR COLOR.

CLASS 9—ELECTRICAL AND SCIENTIFIC APPARATUS

FOR DOWNLOADABLE SOFTWARE PROGRAM THAT UTILIZES ONLINE CONNECTIVITY AND SOCIAL NETWORKING FEATURES TO FACILITATE REGISTERED USERS IN GIVING MONEY TO ONE ANOTHER (U.S. CLS. 21, 23, 26, 36 AND 38).

CLASS 42—SCIENTIFIC AND COMPUTER SERVICES

FOR COMPUTER SERVICES, NAMELY, CREATING AN ONLINE COMMUNITY FOR REGISTERED USERS TO UPLOAD AND SHARE TEXTUAL, PHOTOGRAPHIC, AUDIO AND VIDEO CONTENT REGARDING THEIR FINANCIAL NEEDS, VOTE FOR WORTHY RECIPIENTS OF FINANCIAL DONATIONS AND ENGAGE IN SOCIAL NETWORKING; PROVIDING TEMPORARY USE OF A NON-DOWNLOADABLE SOFTWARE PROGRAM THAT UTILIZES ONLINE CONNECTIVITY AND SOCIAL NETWORKING FEATURES TO FACILITATE REGISTERED USERS IN GIVING MONEY TO ONE ANOTHER (U.S. CLS. 100 AND 101).

CLASS 45—PERSONAL AND LEGAL SERVICES

FOR ONLINE, INTERACTIVE SOCIAL NETWORKING IN THE FIELD OF FINANCIAL DONATIONS (U.S. CLS. 100 AND 101).

JULIE VEPPUMTHARA, EXAMINING ATTORNEY

SN 85-166,416. SIGNATURE DNA, LLC, LEE'S SUMMIT, MO.
FILED 11-1-2010.

SIGNATURE DNA

THE MARK CONSISTS OF STANDARD CHARACTERS WITHOUT CLAIM TO ANY PARTICULAR FONT, STYLE, SIZE, OR COLOR.

NO CLAIM IS MADE TO THE EXCLUSIVE RIGHT TO USE "DNA", APART FROM THE MARK AS SHOWN.

CLASS 40—MATERIAL TREATMENT

FOR CREATION OF CUSTOM ARTWORK CONTAINING GENETIC INFORMATION (U.S. CLS. 100, 103 AND 106).

CLASS 42—SCIENTIFIC AND COMPUTER SERVICES

FOR DESIGN OF CUSTOM ARTWORK CONTAINING GENETIC INFORMATION (U.S. CLS. 100 AND 101).

ROBERT STRUCK, EXAMINING ATTORNEY

SN 85-166,917. ZURICH INSURANCE COMPANY LTD,
ZURICH, SWITZERLAND, FILED 11-2-2010.

ZURICH SHIELD

SN 85-166,610. AEGIS SCIENCES CORPORATION, NASH-
VILLE, TN. FILED 11-1-2010.

THE MARK CONSISTS OF STANDARD CHARACTERS WITHOUT CLAIM TO ANY PARTICULAR FONT, STYLE, SIZE, OR COLOR.

OWNER OF U.S. REG. NOS. 1,213,689, 1,941,954 AND OTHERS.
SEC. 2(F) AS TO "ZURICH".

CLASS 3—COSMETICS AND CLEANING PREPARATIONS

FOR POLYMER SEALANT FOR AUTOMOBILE WINDSHIELDS (U.S. CLS. 1, 4, 6, 50, 51 AND 52).

CLASS 37—CONSTRUCTION AND REPAIR

FOR REPAIR OF AUTOMOBILES, NAMELY, AUTOMOBILE BODY REPAIR (U.S. CLS. 100, 103 AND 106).
KELLY BOULTON, EXAMINING ATTORNEY

THE COLOR(S) GOLD, DARK BROWN, SILVER AND BLUE IS/ARE CLAIMED AS A FEATURE OF THE MARK.

THE MARK CONSISTS OF A CIRCULAR GOLD SHIELD THAT HAS A BLUE OUTLINE. THE INTERIOR BORDER OF THE SHIELD CONTAINS A GREEK KEY DESIGN IN DARK BROWN. THE TERM "AEGIS" APPEARS IN GOLD STYLIZED LETTERING ACROSS THE MIDDLE OF THE SHIELD WITH THE CROSS STROKE OF THE "A" ARCING UP OVER THE REST OF THE TERM. GREEK LETTERING APPEARS IN SILVER IN AN ARC IN THE UPPER AND LOWER PORTION OF THE SHIELD. A BLUE AND DARK BROWN REFLECTION APPEARS ACROSS THE CENTER OF THE SHIELD.

THE NON-LATIN CHARACTERS IN THE MARK TRANSLITERATE TO EPISTEME ASPIDA AMUNA DIKAIOSUNE AND THIS MEANS SCIENCE SHIELD PROTECTION JUSTICE IN ENGLISH.

CLASS 44—MEDICAL, BEAUTY AND AGRICULTURAL SERVICES

FOR PROVIDING HEALTH AND MEDICAL INFORMATION IN THE FIELDS OF DRUGS, STEROIDS, AND THE PRESENCE OF DRUGS AND STEROIDS IN DIETARY, FOOD AND NUTRITIONAL PRODUCTS; CONSULTING SERVICES IN THE FIELD OF SPORTS DOPING AND SUBSTANCE ABUSE PREVENTION AND TESTING PROGRAMS (U.S. CLS. 100 AND 101).

CLASS 45—PERSONAL AND LEGAL SERVICES

FOR PROVIDING INFORMATION IN THE FIELD OF COMPLIANCE WITH STATE AND FEDERAL SPORTS ANTI-DOPING LAWS AND REGULATIONS; PROVIDING INFORMATION IN THE FIELD OF COMPLIANCE WITH SPORTS GOVERNING BODIES' AND SPORTS TEAMS' ANTI-DOPING RULES (U.S. CLS. 100 AND 101).
JULIE VEPPUMTHARA, EXAMINING ATTORNEY

SN 85-168,346. OUT OF THE WOODS CUSTOM CABINETRY, INC., LAYTON, UT. FILED 11-3-2010.



NO CLAIM IS MADE TO THE EXCLUSIVE RIGHT TO USE "CUSTOM CABINETRY & WOODWORKING", APART FROM THE MARK AS SHOWN.

THE MARK CONSISTS OF FOUR CONIFEROUS TREES OF VARIOUS SIZES BELOW WHICH APPEARS THE WORDING "OUT OF THE" ABOVE THE WORDING "WOODS" WITH THIS WORDING OUTLINED. BELOW THIS WORDING APPEARS THE STYLIZED WORDING "CUSTOM CABINETRY & WOODWORKING" IN SOLID CAPITAL LETTERS.

CLASS 19—NON-METALLIC BUILDING MATERIALS

FOR (BASED ON INTENT TO USE) CONSTRUCTION MATERIALS, NAMELY, COMPOSITE PANELS CONSISTING OF A RIGID EXPANDED POLYSTYRENE CORE BONDED TO AN OUTER SKIN OF MDF (MEDIUM-DENSITY FIBERBOARD) WOOD SHEET; CONSTRUCTION MATERIALS, NAMELY, NON-METAL FLOORING MATERIALS; CONSTRUCTION MATERIALS, NAMELY, NON-METAL MATERIALS FOR CONSTRUCTING FLOORS; CONSTRUCTION TIMBER; ENGINEERED HARDWOOD FLOORING; FIREPLACE MANTELS; FLOOR BOARDS; HARD WOOD FLOORING; HARDWOOD FLOORING; MILLWORK, EXCLUSIVE OF CABINETS; PARQUET FLOORING MADE OF WOOD; WOOD DOOR FRAMES; WOOD MOLDINGS; WOOD PANNELLING; WOOD POSTS; WOOD TRIM; WOOD VENEER; WOODEN DOORS; WOODEN FLOORING (U.S. CLS. 1, 12, 33 AND 50).

CLASS 20—FURNITURE AND ARTICLES NOT OTHERWISE CLASSIFIED

FOR (BASED ON INTENT TO USE) CABINET DOORS FOR FURNITURE CABINETS; CABINET DRAWERS FOR FURNITURE CABINETS; CABINETS; CABINETWORK; KITCHEN CABINETS (U.S. CLS. 2, 13, 22, 25, 32 AND 50).

CLASS 37—CONSTRUCTION AND REPAIR

FOR (BASED ON USE IN COMMERCE) HARDWOOD FLOOR COATING SERVICES; INSTALLATION OF KITCHEN CABINETS; INSTALLING WOOD FLOORING (U.S. CLS. 100, 103 AND 106).

FIRST USE 4-1-2004; IN COMMERCE 4-1-2004.

CLASS 40—MATERIAL TREATMENT

FOR (BASED ON USE IN COMMERCE) CABINET MAKING; CUSTOM FABRICATION AND PRODUCTION OF CABINETS; WOODWORKING (U.S. CLS. 100, 103 AND 106).

FIRST USE 4-1-2004; IN COMMERCE 4-1-2004.

ANDREA HACK, EXAMINING ATTORNEY

SN 85-168,432. BOLLA OIL CORP., GARDEN CITY, NY.
FILED 11-3-2010.

BOLLA

THE MARK CONSISTS OF STANDARD CHARACTERS WITHOUT CLAIM TO ANY PARTICULAR FONT, STYLE, SIZE, OR COLOR.

CLASS 35—ADVERTISING AND BUSINESS

FOR RETAIL CONVENIENCE STORE SERVICES (U.S. CLS. 100, 101 AND 102).

FIRST USE 12-31-2003; IN COMMERCE 12-31-2003.

CLASS 37—CONSTRUCTION AND REPAIR

FOR AUTOMOBILE WASHING SERVICES; REPAIR AND MAINTENANCE OF AUTOMOBILES (U.S. CLS. 100, 103 AND 106).

FIRST USE 12-31-2003; IN COMMERCE 12-31-2003.

CLASS 43—HOTEL AND RESTAURANT SERVICES

FOR PROVIDING OF FOOD AND BEVERAGES FOR CONSUMPTION ON AND OFF THE PREMISES (U.S. CLS. 100 AND 101).

FIRST USE 12-31-2003; IN COMMERCE 12-31-2003.

JESSICA FATHY, EXAMINING ATTORNEY

SN 85-168,460. BOLLA OIL CORP., GARDEN CITY, NY.
FILED 11-3-2010.



THE MARK CONSISTS OF THE PROFILE OF A ROARING LION'S HEAD, WITHIN A CIRCLE, WITH A THIN BAND AROUND THE OUTER EDGE OF THE CIRCLE, WITHIN A SQUARE. APPEARING BELOW THE LION'S HEAD, CIRCLE AND SQUARE IS THE STYLIZED WORD "BOLLA", ALL WITHIN A LARGE RECTANGLE.

CLASS 35—ADVERTISING AND BUSINESS

FOR RETAIL CONVENIENCE STORE SERVICES (U.S. CLS. 100, 101 AND 102).

FIRST USE 12-31-2007; IN COMMERCE 12-31-2007.

CLASS 37—CONSTRUCTION AND REPAIR

FOR AUTOMOBILE WASHING SERVICES; REPAIR AND MAINTENANCE OF AUTOMOBILES (U.S. CLS. 100, 103 AND 106).

FIRST USE 12-31-2007; IN COMMERCE 12-31-2007.

CLASS 43—HOTEL AND RESTAURANT SERVICES

FOR PROVIDING OF FOOD AND BEVERAGES FOR CONSUMPTION ON AND OFF THE PREMISES (U.S. CLS. 100 AND 101).

FIRST USE 12-31-2007; IN COMMERCE 12-31-2007.

JESSICA FATHY, EXAMINING ATTORNEY

SN 85-169,897. WANG, PO-CHUNG, ZHUBEI CITY, HSINCHU C, TAIWAN, FILED 11-5-2010.

Ledionopto

THE MARK CONSISTS OF STANDARD CHARACTERS WITHOUT CLAIM TO ANY PARTICULAR FONT, STYLE, SIZE, OR COLOR.

CLASS 9—ELECTRICAL AND SCIENTIFIC APPARATUS

FOR ILLUMINATED EXIT SIGNS (U.S. CLS. 21, 23, 26, 36 AND 38).

CLASS 11—ENVIRONMENTAL CONTROL APPARATUS

FOR LIGHTING FIXTURES FOR OUTDOOR AND INDOOR LIGHTING APPLICATIONS, LED LIGHT FIXTURES, ENERGY SAVING LIGHT BULBS; LIGHT EMITTING DIODE LIGHTING FIXTURES; PENDENT LAMPS; DESK LAMPS; DOWN LIGHTS; WALL LIGHTS; DECORATIVE LIGHTS, NAMELY, CHANDELIERS, DECORATIVE WALL LIGHTS, DECORATIVE CEILING LIGHTS, ELECTRIC HOLIDAY LIGHTS, LED LANDSCAPE LIGHTS, ELECTRIC LIGHTS FOR CHRISTMAS TREES; THEATRICAL STAGE LIGHTING APPARATUS; FLOOR LAMPS; PROJECT LIGHTS, NAMELY, STREET-LIGHTS, LIGHTS FOR ILLUMINATING OUTDOOR SQUARES, PARKS, LAWNS AND GARDENS, PLAY-GROUNDS, TENNIS COURTS, GOLF COURSES, BASKETBALL COURTS AND SOCCER FIELDS; LIGHTS FOR USE IN ILLUMINATING SIGNS AND DISPLAYS; WALL LIGHTS AND TRACK LIGHTS FOR ILLUMINATING WORKS OF ART, AIRPORTS, RAILWAY STATIONS, WORKSHOP FACTORIES AND SHOPPING MALLS; PROJECT LIGHTS, NAMELY, LED LIGHTS FOR USE BY DJ'S AND IN BARS, NIGHTCLUBS, PUBS AND PARTY VENUES; PROJECT LIGHTS, NAMELY, FLOODLIGHTS, PROJECTOR LAMPS ; LIGHT BULBS; PICTURE LIGHTS; TABLE LAMPS; ELECTRIC LAMPS; BURNERS FOR LAMPS; SOCKETS FOR ELECTRIC LIGHTS; HALOGEN LIGHTS; LIGHTING APPARATUS FOR USE IN AUTOMOBILES; LIGHTING APPARATUS FOR VEHICLES; SENSOR LIGHTS FOR USE IN SHOPS, WINDOWS, MALLS, HOTELS, EXHIBITION HALLS, ROOMS AND COUNTERS; YARD LAMPS; CEILING LIGHTS; DOOR LIGHTS; GUIDE LIGHTS; GLOW LAMPS; PENDENT LAMP HOLDERS; SPOTLIGHTS; EMERGENCY LIGHTS; DIRECTION INDICATOR LIGHTS; SEARCHLIGHTS; LIGHT DIFFUSERS; CAST LIGHTS, NAMELY, LIGHTS FOR CASTING TARGETED AND WIDE LIGHT FOR USE IN TENNIS COURTS, PARKING LOTS, STADIUMS, PIERS, PARKS, TREES, LANDSCAPES, INDOOR AREAS AND SCULPTURES (U.S. CLS. 13, 21, 23, 31 AND 34).

LINDA E. BLOHM, EXAMINING ATTORNEY

SN 85-171,103. MARCIA BATES CONSULTING LLC, BERKELEY, CA. FILED 11-8-2010.

REALITY PARTY

THE MARK CONSISTS OF STANDARD CHARACTERS WITHOUT CLAIM TO ANY PARTICULAR FONT, STYLE, SIZE, OR COLOR.

CLASS 16—PAPER GOODS AND PRINTED MATTER

FOR PAPER AND GOODS MADE FROM PAPER, NAMELY, BUMPER STICKERS, POSTERS, NOTEPADS, BOOKS IN THE FIELD OF POLITICAL, ECONOMIC, AND SOCIAL THEORIES (U.S. CLS. 2, 5, 22, 23, 29, 37, 38 AND 50).

CLASS 25—CLOTHING

FOR CLOTHING, NAMELY, T-SHIRTS (U.S. CLS. 22 AND 39).
HEATHER THOMPSON, EXAMINING ATTORNEY

SN 85-171,327. AVATAR PROPERTIES INC., CORAL GABLES, FL. FILED 11-8-2010.

JOSEPH CARL HOMES

THE MARK CONSISTS OF STANDARD CHARACTERS WITHOUT CLAIM TO ANY PARTICULAR FONT, STYLE, SIZE, OR COLOR.

NO CLAIM IS MADE TO THE EXCLUSIVE RIGHT TO USE "HOMES" IN INTERNATIONAL CLASSES 36 AND 37, APART FROM THE MARK AS SHOWN.

THE NAME SHOWN IN THE MARK IDENTIFIES "JOSEPH CARL" MULAC III AND "JOSEPH CARL" MULAC IV, WHOSE CONSENTS TO REGISTER ARE MADE OF RECORD.

CLASS 36—INSURANCE AND FINANCIAL

FOR REAL ESTATE AGENCY SERVICES AND REAL ESTATE BROKERAGE (U.S. CLS. 100, 101 AND 102).

CLASS 37—CONSTRUCTION AND REPAIR

FOR REAL ESTATE DEVELOPMENT SERVICES; LAND DEVELOPMENT SERVICES, NAMELY, PLANNING AND LAYING OUT OF RESIDENTIAL COMMUNITIES, RECREATIONAL FACILITIES, SOCIAL AND COMMUNITY FACILITIES, OFFICE COMPLEXES, SHOPPING CENTERS AND MEETING AND CONVENTION CENTERS; CONSTRUCTION SERVICES, NAMELY, PLANNING, LAYING OUT, AND CONSTRUCTION OF RESIDENCES, RECREATIONAL FACILITIES, SOCIAL AND COMMUNITY FACILITIES AND COMMERCIAL BUILDINGS (U.S. CLS. 100, 103 AND 106).

CLASS 41—EDUCATION AND ENTERTAINMENT

FOR PROVIDING RECREATIONAL FACILITIES, NAMELY, TENNIS COURTS, SWIMMING FACILITIES AND FITNESS AND EXERCISE FACILITIES (U.S. CLS. 100, 101 AND 107).

ANDREW LEASER, EXAMINING ATTORNEY

SN 85-171,354. AVATAR PROPERTIES INC., CORAL GABLES, FL. FILED 11-8-2010.

JCH

THE MARK CONSISTS OF STANDARD CHARACTERS WITHOUT CLAIM TO ANY PARTICULAR FONT, STYLE, SIZE, OR COLOR.

CLASS 36—INSURANCE AND FINANCIAL

FOR REAL ESTATE AGENCY SERVICES AND REAL ESTATE BROKERAGE (U.S. CLS. 100, 101 AND 102).

CLASS 37—CONSTRUCTION AND REPAIR

FOR REAL ESTATE DEVELOPMENT SERVICES; LAND DEVELOPMENT SERVICES, NAMELY, PLANNING AND LAYING OUT OF RESIDENTIAL COMMUNITIES, RECREATIONAL FACILITIES, SOCIAL AND COMMUNITY FACILITIES, OFFICE COMPLEXES, SHOPPING CENTERS AND MEETING AND CONVENTION CENTERS; CONSTRUCTION SERVICES, NAMELY, PLANNING, LAYOUT OUT, AND CONSTRUCTION OF RESIDENCES, RECREATIONAL FACILITIES, SOCIAL AND COMMUNITY FACILITIES AND COMMERCIAL BUILDINGS (U.S. CLS. 100, 103 AND 106).

CLASS 41—EDUCATION AND ENTERTAINMENT

FOR PROVIDING RECREATIONAL FACILITIES, NAMELY, TENNIS COURTS, SWIMMING FACILITIES AND FITNESS AND EXERCISE FACILITIES (U.S. CLS. 100, 101 AND 107).

ANDREW LEASER, EXAMINING ATTORNEY

SN 85-174,091. SENSIENT FLAVORS LLC, INDIANAPOLIS, IN. FILED 11-10-2010.

SENSASALT

THE MARK CONSISTS OF STANDARD CHARACTERS WITHOUT CLAIM TO ANY PARTICULAR FONT, STYLE, SIZE, OR COLOR.

CLASS 29—MEATS AND PROCESSED FOODS

FOR HYDROLYZED VEGETABLE PROTEINS TO REDUCE THE SODIUM IN FOOD (U.S. CL. 46).

CLASS 30—STAPLE FOODS

FOR YEAST EXTRACTS (U.S. CL. 46).
TIMOTHY FINNEGAN, EXAMINING ATTORNEY

SN 85-171,742. SHANDA N. BRUMBY, AKA LA SHANDA N. BRUMBY, HENDERSON, NV. AND JANA E. S. BRUMBY, HENDERSON, NV. FILED 11-8-2010.



THE COLOR(S) BROWN, YELLOW, BLACK, WHITE AND GREEN IS/ARE CLAIMED AS A FEATURE OF THE MARK. THE MARK CONSISTS OF THE WORDING "HONEY CHILD'S". BETWEEN THE TWO WORDS IS A DESIGN OF A BEEHIVE WITH A BRANCH HOLDING THE BEEHIVE. BOTH THE BRANCHES, BEEHIVE, HONEY STICKS, AND THE LETTERS "H" AND "I" ARE OUTLINED IN BROWN. THE LETTERS "H" AND "I" ARE REPLACED WITH THE SHAPE OF HONEY STICKS. EXCEPT FOR THE LETTERS "H" AND "I", BLACK OUTLINES ALL OF THE WORDING. THERE ARE THREE THICK BLACK LINES ACROSS THE BEES BODIES AND HONEY STICKS. THE BEES ANTENNAS AND STINGERS ARE ALSO BLACK. THERE ARE GREEN LEAVES ON THE BRANCHES. THE LETTERS "O", "N", "E", "Y", "C", "H", "L", "D", AND "S" ARE YELLOW AND SO ARE THE BEES. THE OPENING OF THE HIVE IS WHITE, AS ARE THE BACKGROUND AND BEE WINGS. THE APOSTROPHE BETWEEN THE LETTERS "D" AND "S" IN THE WORD "CHILD'S" HAS BEEN REPLACED WITH THE DESIGN OF A BEE SLIGHTLY ARCHED TO RESEMBLE AN APOSTROPHE. YELLOW HONEY DRIPS IN TWO AREAS ON RIGHT-SIDE OF BEEHIVE AND DRIPS IN ONE AREA ON LEFT SIDE OF BEEHIVE. BROWN LINES UNDERLINE THE WORDING "HONEY CHILD'S".

CLASS 4—LUBRICANTS AND FUELS

FOR CANDLES (U.S. CLS. 1, 6 AND 15).

CLASS 30—STAPLE FOODS

FOR COFFEE; TEA; HONEY; CANDY; PASTRIES (U.S. CL. 46).
WILLIAM BRECKENFELD, EXAMINING ATTORNEY

SN 85-174,403. JESSICA CHING PING YANG, BEL-AIR POK FU LAM, HONG KONG, FILED 11-11-2010.

JUST GLAM

THE MARK CONSISTS OF STANDARD CHARACTERS WITHOUT CLAIM TO ANY PARTICULAR FONT, STYLE, SIZE, OR COLOR.

CLASS 25—CLOTHING

FOR CLOTHING, NAMELY, SHIRTS, SWEATSHIRTS, TEE SHIRTS, TANK TOPS, PANTS, SHORTS, SKIRTS, SOCKS, UNDERWEAR, HATS, SCARVES, AND GLOVES (U.S. CLS. 22 AND 39).

CLASS 35—ADVERTISING AND BUSINESS

FOR RETAIL STORE SERVICES FEATURING CLOTHING; ONLINE RETAIL STORE SERVICES FEATURING CLOTHING (U.S. CLS. 100, 101 AND 102).
MARGERY A. TIERNEY, EXAMINING ATTORNEY

SN 85-174,534. INTERNATIONAL GOLDEN FOODS, INC., BENSENVILLE, IL. FILED 11-11-2010.

Sahara Gold

THE MARK CONSISTS OF STANDARD CHARACTERS WITHOUT CLAIM TO ANY PARTICULAR FONT, STYLE, SIZE, OR COLOR.

NO CLAIM IS MADE TO THE EXCLUSIVE RIGHT TO USE "SAHARA", APART FROM THE MARK AS SHOWN.

CLASS 29—MEATS AND PROCESSED FOODS

FOR PROCESSED DATES AND DRIED DATES (U.S. CL. 46).
FIRST USE 8-20-2009; IN COMMERCE 8-20-2009.

CLASS 31—NATURAL AGRICULTURAL PRODUCTS

FOR FRESH DATES; UNPROCESSED DATES AND RAW DATES (U.S. CLS. 1 AND 46).
FIRST USE 8-20-2009; IN COMMERCE 8-20-2009.
PAULA MAHONEY, EXAMINING ATTORNEY

SN 85-174,682. PRECISION DERMATOLOGY, INC., CUMBERLAND, RI. FILED 11-11-2010.

PRECISION DERMATOLOGY

THE MARK CONSISTS OF STANDARD CHARACTERS WITHOUT CLAIM TO ANY PARTICULAR FONT, STYLE, SIZE, OR COLOR.

NO CLAIM IS MADE TO THE EXCLUSIVE RIGHT TO USE "DERMATOLOGY", APART FROM THE MARK AS SHOWN.

CLASS 3—COSMETICS AND CLEANING PREPARATIONS

FOR NON-MEDICATED SKIN CARE PREPARATIONS (U.S. CLS. 1, 4, 6, 50, 51 AND 52).

CLASS 5—PHARMACEUTICALS

FOR PHARMACOLOGICAL PREPARATIONS FOR DERMATOLOGICAL USE (U.S. CLS. 6, 18, 44, 46, 51 AND 52).

JESSICA A. POWERS, EXAMINING ATTORNEY

SN 85-175,079. ARCHBURY LANE HOLDINGS, INC., BOULDER, CO. FILED 11-11-2010.

Archbury Press

THE MARK CONSISTS OF STANDARD CHARACTERS WITHOUT CLAIM TO ANY PARTICULAR FONT, STYLE, SIZE, OR COLOR.

NO CLAIM IS MADE TO THE EXCLUSIVE RIGHT TO USE "PRESS", APART FROM THE MARK AS SHOWN.

CLASS 16—PAPER GOODS AND PRINTED MATTER

FOR BOOKS, NAMELY, NONFICTION BOOKS ON A NUMBER OF TOPICS RELATED TO COOKING AND BAKING PROCESSES AND RECIPES (U.S. CLS. 2, 5, 22, 23, 29, 37, 38 AND 50).

CLASS 41—EDUCATION AND ENTERTAINMENT

FOR PUBLICATION SERVICES, NAMELY, BOOKS AND PRINTED MATERIALS RELATING TO COOKING AND BAKING PROCESSES AND RECIPES (U.S. CLS. 100, 101 AND 107).

BRIAN NEVILLE, EXAMINING ATTORNEY

SN 85-175,210. FELICE BRUNELLO RUSSO, LONDON, UNITED KINGDOM, FILED 11-12-2010.



PRIORITY CLAIMED UNDER SEC. 44(D) ON ERPN CMNTY TM OFC APPLICATION NO. 009121179, FILED 5-20-2010, REG. NO. 9121179, DATED 11-2-2010, EXPIRES 5-20-2020.

THE COLOR(S) RED, BLACK AND GREY IS/ARE CLAIMED AS A FEATURE OF THE MARK.

THE MARK CONSISTS OF THE WORDS "THE LANGUAGE OF EMOTIONS" APPEARING IN BLACK AROUND A CIRCULAR DESIGN, WHERE THE TOP PORTION OF THE CIRCULAR DESIGN APPEARS IN BLACK AND THE LOWER PORTION APPEARS IN RED; THE LETTERING "LE" AND ITS MIRROR IMAGE APPEARS IN LOWER-CASE SCRIPT WITHIN THE CIRCULAR DESIGN, WITH THE UPPER PORTION OF THE "L" APPEARING IN RED, AND THE LOWER PORTION OF THE "L" AND "E" APPEARING IN BLACK; THE LOWER PORTION OF THE MIRROR IMAGE OF THE "LE" APPEARS GREY.

CLASS 3—COSMETICS AND CLEANING PREPARATIONS

FOR NON-MEDICATED PREPARATIONS FOR APPLICATION TO THE SKIN AND SCALP; SOAPS; PERFUMERY; LIPSTICK AND LIP GLOSS; DENTIFRICES; ESSENTIAL OILS; COSMETICS, HAIR LOTIONS; ANTIPERSPIRANTS; DEODORANTS FOR BODY CARE; BATH OILS, SCENTED OILS; NON-MEDICATED TOILETRIES (U.S. CLS. 1, 4, 6, 50, 51 AND 52).

CLASS 16—PAPER GOODS AND PRINTED MATTER

FOR PRINTED MATTER, NAMELY, GIFT CARDS, GREETING CARDS, AND INVITATION CARDS; WRAPPING PAPER AND PACKAGING MATERIALS MADE FROM PAPER AND TISSUE PAPER; PAPER GIFT TAGS, GIFT BAGS MADE OF CARDBOARD OR PAPER; BOXES MADE OF CARDBOARD OR OF PAPER; BINDERS; WRITING IMPLEMENTS (U.S. CLS. 2, 5, 22, 23, 29, 37, 38 AND 50).

CLASS 25—CLOTHING

FOR ARTICLES OF CLOTHING, NAMELY, SHIRTS, BLOUSES, PANTS, SHORTS, DRESSES, COATS, JACKETS, SKIRTS, SWEATERS, SWEATSHIRTS; UNDERCLOTHES; LINGERIE, STOCKINGS, TIGHTS AND LEOTARDS (U.S. CLS. 22 AND 39).

CLASS 30—STAPLE FOODS

FOR NON-MEDICATED CONFECTIONERY, NAMELY, PASTRIES; CHOCOLATE AND CHOCOLATE CONFECTIONERY (U.S. CL. 46).

CLASS 31—NATURAL AGRICULTURAL PRODUCTS

FOR FLOWERS; DRIED FLOWERS; CUT FLOWERS; LIVE PLANTS (U.S. CLS. 1 AND 46).

CLASS 35—ADVERTISING AND BUSINESS

FOR THE BRINGING TOGETHER FOR THE BENEFIT OF OTHERS OF A VARIETY OF GOODS ENABLING CUSTOMERS TO CONVENIENTLY VIEW AND PURCHASE THOSE GOODS BY MEANS OF A MAIL ORDER CATALOG, MAIL ORDER SERVICES AND VIA AN INTERNET WEBSITE, ALL IN RELATION TO NON-MEDICATED PREPARATIONS FOR APPLICATION TO THE SKIN AND SCALP, SOAPS, PERFUMERY, LIPSTICK AND LIP GLOSS, DENTIFRICES, ESSENTIAL OILS, COSMETICS, HAIR LOTIONS, ANTIPERSPIRANTS, DEODORANTS FOR BODY CARE, BATH OILS, SCENTED OILS, NON-MEDICATED TOILETRIES, GIFT CARDS, GREETING CARDS, INVITATION CARDS, WRAPPING PAPER AND PACKAGING MATERIALS MADE FROM PAPER AND TISSUE PAPER, PAPER GIFT TAGS, GIFT BAGS MADE OF CARDBOARD OR PAPER, BOXES MADE OF CARDBOARD OR OF PAPER, BINDERS, WRITING IMPLEMENTS, ARTICLES OF CLOTHING, NAMELY, SHIRTS, BLOUSES, PANTS, SHORTS, DRESSES, COATS, JACKETS, SKIRTS, SWEATERS, SWEATSHIRTS, UNDERCLOTHES, LINGERIE, STOCKINGS, TIGHTS AND LEOTARDS, NON-MEDICATED CONFECTIONERY, NAMELY, PASTRIES, CHOCOLATE AND CHOCOLATE CONFECTIONERY, FLOWERS, DRIED FLOWERS, CUT FLOWERS, LIVE PLANTS (U.S. CLS. 100, 101 AND 102).

CLASS 39—TRANSPORTATION AND STORAGE

FOR DELIVERY OF GIFTS AND GOODS; FLOWER AND PLANT DELIVERY; MESSAGE DELIVERY AND ADVISORY AND CONSULTANCY SERVICES IN CONNECTION WITH THE AFORESAID SERVICES (U.S. CLS. 100 AND 105).

MARC LEIPZIG, EXAMINING ATTORNEY

SN 85-175,955. UNITEDHEALTH GROUP INCORPORATED, MINNETONKA, MN. FILED 11-12-2010.

YOURCARE CONNECTED

THE MARK CONSISTS OF STANDARD CHARACTERS WITHOUT CLAIM TO ANY PARTICULAR FONT, STYLE, SIZE, OR COLOR.

CLASS 16—PAPER GOODS AND PRINTED MATTER

FOR PRINTED MATERIALS, NAMELY, PRINTED GUIDES, PAMPHLETS, BROCHURES, BOOKLETS, BOOKS, MAGAZINES, NEWSLETTERS, AND TEACHING MATERIALS IN THE FIELD OF HEALTHCARE INFORMATION AND EDUCATION (U.S. CLS. 2, 5, 22, 23, 29, 37, 38 AND 50).

CLASS 41—EDUCATION AND ENTERTAINMENT

FOR EDUCATION SERVICES, NAMELY, PROVIDING SEMINARS IN THE FIELDS OF HEALTH AND HEALTHCARE (U.S. CLS. 100, 101 AND 107).

CLASS 42—SCIENTIFIC AND COMPUTER SERVICES

FOR PROVIDING A WEBSITE FEATURING ON-LINE NON-DOWNLOADABLE SOFTWARE TOOLS IN THE FIELDS OF HEALTH CARE AND HEALTH CARE EDUCATION FOR PATIENTS AND HEALTHCARE PROFESSIONALS; COMPUTER SERVICES, NAMELY, PROVIDING A WEB-BASED SYSTEM AND ONLINE PORTAL FEATURING ON-LINE NON-DOWNLOADABLE SOFTWARE THAT ENABLES USERS TO ACCESS TRAINING AND EDUCATION MATERIALS IN THE FIELDS OF HEALTH AND HEALTHCARE (U.S. CLS. 100 AND 101).

CLASS 44—MEDICAL, BEAUTY AND AGRICULTURAL SERVICES

FOR PROVIDING AN INTERACTIVE WEBSITE FEATURING INFORMATION AND LINKS RELATING TO HEALTHCARE, HEALTH OUTREACH AND INTERVENTION; PROVIDING HEALTH INFORMATION; PROVIDING HEALTH CARE INFORMATION BY TELEPHONE AND THE INTERNET (U.S. CLS. 100 AND 101).

REGINA DRUMMOND, EXAMINING ATTORNEY

SN 85-176,453. POKOY-KURTULUS, JOYCE, MONTCLAIR, NJ. FILED 11-15-2010.

KookiLolli

THE MARK CONSISTS OF STANDARD CHARACTERS WITHOUT CLAIM TO ANY PARTICULAR FONT, STYLE, SIZE, OR COLOR.

CLASS 14—JEWELRY

FOR COSTUME JEWELRY (U.S. CLS. 2, 27, 28 AND 50).

CLASS 16—PAPER GOODS AND PRINTED MATTER

FOR STATIONERY ITEMS, NAMELY, PENS, PENCILS, GREETING CARDS, NOTE CARDS, NOTEBOOKS, NOTEBOOK COVERS, NOTE PADS, PENCIL CASES, ERASERS, STICKERS, BOOKMARKS, DIARIES, HOLDERS FOR DESK ACCESSORIES, AND CALENDARS (U.S. CLS. 2, 5, 22, 23, 29, 37, 38 AND 50).

CLASS 26—FANCY GOODS

FOR HAIR ACCESSORIES, NAMELY, HAIR BANDS; PONYTAIL HOLDERS, NAMELY, HAIR TIES; BARRIETTES, HAIR CLIPS, HAIR BOWS, AND BOBBY PINS (U.S. CLS. 37, 39, 40, 42 AND 50).

CARYN GLASSER, EXAMINING ATTORNEY

SN 85-178,106. DAYSPRING CARDS, INC., SILOAM SPRINGS, AR. FILED 11-16-2010.

YOUR HEART. GOD'S LOVE.

THE MARK CONSISTS OF STANDARD CHARACTERS WITHOUT CLAIM TO ANY PARTICULAR FONT, STYLE, SIZE, OR COLOR.

CLASS 16—PAPER GOODS AND PRINTED MATTER

FOR PLUSH COVERING FOR BOOKS, PLUSH COVERING FOR PHOTO ALBUMS (U.S. CLS. 2, 5, 22, 23, 29, 37, 38 AND 50).

CLASS 28—TOYS AND SPORTING GOODS

FOR PLUSH TOYS (U.S. CLS. 22, 23, 38 AND 50).
DANNEAN HETZEL, EXAMINING ATTORNEY

SN 85-178,405. ZE FRANK GAMES, INC., LOS ANGELES, CA. FILED 11-16-2010.

STAR.ME

THE MARK CONSISTS OF STANDARD CHARACTERS WITHOUT CLAIM TO ANY PARTICULAR FONT, STYLE, SIZE, OR COLOR.

CLASS 9—ELECTRICAL AND SCIENTIFIC APPARATUS

FOR COMPUTER SOFTWARE PLATFORMS FOR GAMING; COMPUTER SOFTWARE PLATFORMS FOR GAME DEVELOPMENT AND CUSTOMIZATION; COMPUTER GAME SOFTWARE; COMPUTER GAME PROGRAMS DOWNLOADABLE VIA THE INTERNET; COMPUTER GAME SOFTWARE FOR USE ON MOBILE AND CELLULAR PHONES; ELECTRONIC GAME SOFTWARE FOR HANDHELD ELECTRONIC DEVICES (U.S. CLS. 21, 23, 26, 36 AND 38).

CLASS 41—EDUCATION AND ENTERTAINMENT

FOR PROVIDING A WEB-BASED SYSTEM AND ON-LINE PORTAL FOR CUSTOMERS TO PARTICIPATE IN ON-LINE GAMING, OPERATION AND COORDINATION OF GAME TOURNAMENTS AND LEAGUES; ENTERTAINMENT SERVICES, NAMELY, PROVIDING ON-LINE COMPUTER GAMES; ENTERTAINMENT SERVICES, NAMELY, PROVIDING TEMPORARY USE OF NON-DOWNLOADABLE INTERACTIVE GAMES; ENTERTAINMENT SERVICES, NAMELY, PROVIDING GAMES ON-LINE AND IN MOBILE WIRELESS FORM; ENTERTAINMENT SERVICES, NAMELY, PROVIDING TEMPORARY USE OF NON-DOWNLOADABLE COMPUTER GAMES; AND (U.S. CLS. 100, 101 AND 107).

CLASS 42—SCIENTIFIC AND COMPUTER SERVICES

FOR COMPUTER SERVICES, NAMELY, CREATING AN ON-LINE COMMUNITY FOR REGISTERED USERS TO PARTICIPATE IN COMPETITIONS, SHOWCASE THEIR SKILLS, GET FEEDBACK FROM THEIR PEERS, FORM VIRTUAL COMMUNITIES, ENGAGE IN SOCIAL NETWORKING AND IMPROVE THEIR TALENT; HOSTING AN ON-LINE COMMUNITY WEB SITE FEATURING COMPUTER GAMES (U.S. CLS. 100 AND 101).
PAULA MAHONEY, EXAMINING ATTORNEY

SN 85-179,078. CENTRO STORICO S.R.L., FIRENZE, ITALY, FILED 11-17-2010.

ACQUA AL 2

THE MARK CONSISTS OF STANDARD CHARACTERS WITHOUT CLAIM TO ANY PARTICULAR FONT, STYLE, SIZE, OR COLOR.

OWNER OF U.S. REG. NO. 2,149,928.
THE ENGLISH TRANSLATION OF "ACQUA" IN THE MARK IS "WATER" AND "AL" MEANS "AT".

CLASS 29—MEATS AND PROCESSED FOODS

FOR PRESERVED, DRIED AND COOKED FRUITS AND VEGETABLES; JELLIES, JAMS, COMPOTES; MILK, CHEESE AND YOGURT, EDIBLE OILS, VINEGAR, TOMATO PUREE, CANNED TOMATO, PICKLES, NAMELY, CUCUMBERS, VEGETABLES PRESERVED IN OIL, NAMELY, OLIVES, MUSHROOMS AND TOMATOES (U.S. CL. 46).

CLASS 30—STAPLE FOODS

FOR BREAD, COOKIES, ICE-CREAMS; HONEY, MUSTARD, VINEGAR, SAUCES, TOMATO SAUCES, COOKING SAUCES, HOT SAUCES, SALAD DRESSINGS, CHEESE SAUCES, BARBECUE SAUCES, PIZZA SAUCES, SOYA SAUCES, PASTA; SPICES; MAYONNAISE (U.S. CL. 46).

LINDA MICKLEBURGH, EXAMINING ATTORNEY

SN 85-179,788. ANTEA USA, INC., SHOREVIEW, MN. FILED 11-18-2010.



THE COLOR(S) SHADES OF TEAL (BLUE-GREEN) IS/ ARE CLAIMED AS A FEATURE OF THE MARK.

THE MARK CONSISTS OF THREE CIRCULAR SHAPES EACH IN DIFFERENT SIZES AND DIFFERENT SHADES OF TEAL ONE IS SOLID THE OTHER TWO ARE RINGS.

CLASS 35—ADVERTISING AND BUSINESS

FOR ADVERTISING AND BUSINESS MANAGEMENT CONSULTING; COMMERCIAL BUSINESS MANAGEMENT; BUSINESS ADMINISTRATION AND OFFICE FUNCTIONS; MARKET RESEARCH; MARKET ANALYSIS; BUSINESS CONSULTING IN THE FIELD OF ENVIRONMENTAL MANAGEMENT, NAMELY, ADVISING BUSINESSES ON ISSUES OF ENVIRONMENTAL IMPACT, CONSERVATION, PRESERVATION AND PROTECTION, AND ECONOMIC ANALYSIS FOR BUSINESS PURPOSES (U.S. CLS. 100, 101 AND 102).

CLASS 40—MATERIAL TREATMENT

FOR ENVIRONMENTAL REMEDIATION SERVICES, NAMELY, SOIL, WASTE AND/OR WATER TREATMENT SERVICES; HAZARDOUS WASTE MANAGEMENT; TREATMENT OF WASTE MATERIALS IN SOLID AND LIQUID FORMS; TREATMENT OF SOIL, SAND AND MATERIALS RESEMBLING SOIL; TREATMENT OF MATERIALS, NAMELY, EFFECTING SOIL INJECTIONS IN ORDER TO MAKE THE SOIL WATER RESISTANT OR TO HARDEN THE SOIL CONSTRUCTIVELY; ENVIRONMENTAL REMEDIATION SERVICES BY AN INJECTION COMPANY SPECIALIZED IN SOIL INJECTION TECHNIQUES, NAMELY, HORIZONTAL SOIL INJECTIONS, CONSTRUCTIVE SOIL INJECTIONS, GROUTED AND DAMMING INJECTIONS, INJECTIONS OF PROPERTY WITH DAMP LEAKAGES, BELOW GROUND LEVEL; TREATMENT OF MATERIALS FOR THE PURPOSE OF SOIL SANITATION AND SOIL DECONTAMINATION; ENVIRONMENTAL REMEDIATION CONSULTING SERVICES IN THE FIELD OF SOIL, AIR, WASTE AND WATER TREATMENT; SERVICES IN THE FIELD OF PROCESSING AND TREATMENT OF STEEL; PROCESSING, TREATMENT AND RECYCLING OF MINERAL AND ORGANIC SUBSTANCES, OF MATERIALS AND WASTE MATERIALS INTO SOLID OR LIQUID FERTILIZERS AND MIXTURES; OVERSIGHT MANAGEMENT OF HAZARDOUS AND NON-HAZARDOUS WASTES (U.S. CLS. 100, 103 AND 106).

CLASS 41—EDUCATION AND ENTERTAINMENT

FOR DEVELOPMENT OF HEALTH AND SAFETY TRAINING PROGRAMS FOR OTHERS (U.S. CLS. 100, 101 AND 107).

CLASS 42—SCIENTIFIC AND COMPUTER SERVICES

FOR CONSULTING SERVICES IN THE FIELD OF ENVIRONMENTAL ASSESSMENT AND PLANNING; ENGINEERING AND SURVEYOR SERVICES FOR BUILDING AND PROPERTY CONDITION ASSESSMENT; COMPUTER PROGRAMMING FOR ELECTRONIC DATA PROCESSING; DRAWING UP EXPERT REPORTS BY ENGINEERS AND LABORATORY TECHNICIANS; TECHNICAL CONSULTATION IN THE FIELD OF ENVIRONMENTAL ENGINEERING; SOIL ANALYSIS; PHOTOGRAMMETRY; PHOTOGRAMMETRIC MAP PRODUCTION; CONDUCTING AERIAL SURVEYS; PROVIDING INFORMATION IN THE FIELD OF GEOGRAPHY, NAMELY, IDENTIFICATION, ANALYSIS, AND INTERPRETATION OF THE DISTRIBUTION AND ARRANGEMENT OF LANDFORMS AND OTHER FEATURES OF THE EARTH'S SURFACE; SERVICES OF CHEMISTS, ENGINEERS, GEOGRAPHERS, NAMELY, MAPPING AND CARTOGRAPHY, ARCHITECTS AND LAND SURVEYORS; CONSULTING SERVICES RELATING TO HAZARDOUS MATERIALS MANAGEMENT; EVALUATION AND TESTING OF REAL ESTATE FOR THE PRESENCE OF HAZARDOUS MATERIAL; EVALUATING AND TESTING THE ENVIRONMENTAL QUALITIES AND IMPACT OF CONSUMER PRODUCTS FOR OTHERS; CONSULTING IN THE FIELD OF FACILITY WATER STEWARDSHIP, WATER MANAGEMENT AND IMPLEMENTATION OF WATER CONSERVATION PRACTICES; CONSULTING ON SOURCE WATER PROTECTION PROGRAMS; THIRD PARTY CERTIFICATION AUDITS, NAMELY, TESTING, ANALYSIS AND EVALUATION OF THIRD PARTY SERVICES FOR THE

PURPOSE OF CERTIFICATION; ENVIRONMENTAL CONSULTING SERVICES, NAMELY, TECHNICAL CONSULTATION IN THE FIELD OF ENVIRONMENTAL ENGINEERING; ENVIRONMENTAL EVALUATION AND DUE DILIGENCE REVIEW FOR THE PRESENCE OF HAZARDOUS MATERIAL PRIOR TO PURCHASE AND SALE OF REAL ESTATE; DESIGN OF PETROLEUM HANDLING FACILITIES, AQUIFER RESTORATION SYSTEMS AND MINE DEWATERING SYSTEMS; DRAWING UP TECHNICAL EXPERT REPORTS IN THE FIELD OF SOIL SANITATION AND TREATMENT (U.S. CLS. 100 AND 101).

CLASS 45—PERSONAL AND LEGAL SERVICES

FOR LOCAL REGIONAL AND GLOBAL REGULATORY COMPLIANCE CONSULTING IN THE FIELD OF ENVIRONMENTAL, HEALTH AND SAFETY; CONDUCTING ENVIRONMENTAL, HEALTH AND SAFETY COMPLIANCE AUDITS; AUDITING OF OCCUPATIONAL HEALTH AND SAFETY PROGRAMS; TECHNICAL CONSULTATION IN THE FIELD OF OCCUPATIONAL HEALTH AND SAFETY; ENVIRONMENTAL REGULATION COMPLIANCE CONSULTING, NAMELY, REVIEWING STANDARDS AND PRACTICES TO ASSURE COMPLIANCE WITH ENVIRONMENTAL AND OSHA LAWS AND REGULATIONS; PERMITTING, NAMELY, OBTAINING ENVIRONMENTAL, DESIGN, ZONING AND OTHER GOVERNMENTAL PERMITS FOR DEVELOPMENT PROJECTS (U.S. CLS. 100 AND 101).

JAMES A. RAUEN, EXAMINING ATTORNEY

SN 85-180,647. I & O INVESTMENTS INC, MIAMI BEACH, FL. FILED 11-19-2010.

ADD ON FASHION

THE MARK CONSISTS OF STANDARD CHARACTERS WITHOUT CLAIM TO ANY PARTICULAR FONT, STYLE, SIZE, OR COLOR.

NO CLAIM IS MADE TO THE EXCLUSIVE RIGHT TO USE "FASHION", APART FROM THE MARK AS SHOWN.

CLASS 14—JEWELRY

FOR PRECIOUS METALS, THEIR ALLOYS AND GOODS IN PRECIOUS METALS OR COATED THEREWITH, NAMELY, PENDANTS, NECKLACES, WATCHES, EARRINGS, RINGS, BRACELETS, CUFF LINKS, BROOCHES, AND JEWELRY BOXES, NAMELY, RING BOXES (U.S. CLS. 2, 27, 28 AND 50).

CLASS 18—LEATHER GOODS

FOR GOODS MADE OF LEATHER AND IMITATION LEATHER, NAMELY, WALLETS, FASHION BAGS, NAMELY, HANDBAGS AND ALL-PURPOSE CARRYING BAGS, TRAVEL BAGS AND LUGGAGE (U.S. CLS. 1, 2, 3, 22 AND 41).

CLASS 25—CLOTHING

FOR CLOTHING, NAMELY, BELTS, FOOTWEAR, HATS, SWIMWEAR, TIES, SCARVES, TOPS, SKIRTS, SHIRTS, BLOUSES, PANTS, DRESSES, SWEATERS, BLAZERS, JACKETS, COATS, SOCKS, TIGHTS, LEGGINGS; GOODS IN PRECIOUS METALS OR COATED THEREWITH, NAMELY, BELTS; GOODS MADE OF LEATHER AND IMITATION LEATHER, NAMELY, FOOTWEAR AND GLOVES (U.S. CLS. 22 AND 39).

BRIAN CALLAGHAN, EXAMINING ATTORNEY

SN 85-180,852. AMERICAN TELECONFERENCING SERVICES, LTD., ATLANTA, GA. FILED 11-19-2010.

GLOBALMEET

THE MARK CONSISTS OF STANDARD CHARACTERS WITHOUT CLAIM TO ANY PARTICULAR FONT, STYLE, SIZE, OR COLOR.

OWNER OF U.S. REG. NO. 3,076,139.

CLASS 9—ELECTRICAL AND SCIENTIFIC APPARATUS

FOR SOFTWARE FOR COMMUNICATIONS AND CONFERENCING SERVICES, NAMELY, SOFTWARE FOR USE IN PROVIDING ACCESS TO TELEPHONE, VIDEO AND INTERNET CONFERENCES; SOFTWARE FOR PROCESSING, TRANSMITTING, RECEIVING, RECORDING, REPRODUCING, AND MANAGING SOUND, IMAGES, AND DATA IN ONLINE AND MOBILE MEETINGS AND CONFERENCES; COMMUNICATIONS SOFTWARE FOR USE IN CONNECTING USERS OF COMPUTER NETWORKS, WIRELESS ELECTRONIC COMMUNICATIONS DEVICES, COMMUNICATIONS NETWORKS, INFORMATION SERVICES NETWORKS, DATA NETWORKS, LOCAL COMPUTER NETWORKS, GLOBAL COMPUTER NETWORKS, AND THE INTERNET; SOFTWARE FOR USE IN PROCESSING, TRANSMITTING, RECEIVING, RECORDING, REPRODUCING, AND MANAGING VOICE, MESSAGES, DATA, DOCUMENTS, SIGNALS, IMAGES, VIDEO, DIGITAL MEDIA CONTENT, AND AUDIO, VISUAL, AND AUDIOVISUAL MATERIALS VIA COMPUTERS, ELECTRONIC DEVICES, COMMUNICATIONS NETWORKS, INFORMATION SERVICES NETWORKS, DATA NETWORKS, LOCAL COMPUTER NETWORKS, GLOBAL COMPUTER NETWORKS, AND THE INTERNET; SOFTWARE PLATFORMS FOR SCHEDULING, HOSTING, JOINING, MANAGING, AND STREAMING AUDIO CONFERENCES, NETWORK CONFERENCES, TELECONFERENCES, TELEPHONE CONFERENCES, VIDEO CONFERENCES, VIDEO TELECONFERENCES, VOICE OVER INTERNET PROTOCOL (VOIP) CONFERENCES, WEB CONFERENCES, AND INSTANT MESSAGING VIA THE INTERNET; SOFTWARE THAT PROVIDES WEB-BASED ACCESS TO APPLICATIONS AND SERVICES THROUGH A WEB OPERATING SYSTEM OR PORTAL INTERFACE; SOFTWARE, NAMELY, SOFTWARE DEVELOPMENT TOOLS FOR THE CREATION OF ONLINE AND MOBILE APPLICATIONS AND CLIENT INTERFACES (U.S. CLS. 21, 23, 26, 36 AND 38).

CLASS 38—COMMUNICATION

FOR COMMUNICATIONS AND CONFERENCING SERVICES, NAMELY, PROVIDING TELEPHONE, VIDEO AND INTERNET COMMUNICATIONS SERVICES AND EQUIPMENT FOR TELEPHONE, VIDEO AND INTERNET CONFERENCING; COMMUNICATION SERVICES, NAMELY, TRANSMITTING AND STREAMING VOICE, MESSAGES, DATA, DOCUMENTS, SIGNALS, IMAGES, VIDEO, DIGITAL MEDIA CONTENT, AND AUDIO, VISUAL, AND AUDIOVISUAL MATERIALS VIA COMPUTERS, ELECTRONIC DEVICES, COMMUNICATIONS NETWORKS, INFORMATION SERVICES NETWORKS, DATA NETWORKS, LOCAL COMPUTER NETWORKS, GLOBAL COMPUTER NETWORKS, AND THE INTERNET; PROVIDING ACCESS AND COMMUNICATIONS CONNECTIONS TO MULTINATIONAL TELECOMMUNICATION NETWORKS; INSTANT MESSAGING SERVICES; INTERACTIVE DELIVERY OF VIDEO OVER DIGITAL NETWORKS; PROVIDING ACCESS AND COMMUNICATIONS CONNECTIONS TO COMMUNICATIONS VIA TELECOMMUNICATION NETWORKS; PROVIDING ACCESS AND COMMUNICATIONS CONNECTIONS TO LOCAL COMPUTER NETWORKS, GLOBAL COMPUTER NETWORKS, AND THE INTERNET; PROVIDING VOICE COMMUNICATION SERVICES VIA THE INTERNET; TRANSMISSION OF

DIGITAL MEDIA CONTENT, AUDIO, VISUAL, AND AUDIOVISUAL MATERIALS FROM WEB CAMS, VIDEO CAMERAS, OR MOBILE PHONES, ALL FEATURING LIVE OR RECORDED MATERIALS; VOICE OVER INTERNET PROTOCOL (VOIP) SERVICES; AUDIO CONFERENCING SERVICES; NETWORK CONFERENCING SERVICES; TELECONFERENCING SERVICES; TELEPHONE CONFERENCING SERVICES; VIDEO CONFERENCING SERVICES; VIDEO TELECONFERENCING SERVICES; VOICE OVER INTERNET PROTOCOL (VOIP) CONFERENCING SERVICES; WEB CONFERENCING SERVICES (U.S. CLS. 100, 101 AND 104).

CLASS 42—SCIENTIFIC AND COMPUTER SERVICES

FOR COMPUTER SERVICES, NAMELY, DESIGN AND DEVELOPMENT OF COMPUTER SOFTWARE; APPLICATION SERVICE PROVIDER FEATURING APPLICATION PROGRAMMING INTERFACE (API) SOFTWARE FOR USE IN CONNECTION WITH ACCESS, RETRIEVAL, UPLOAD, AND MANAGEMENT OF VOICE, MESSAGES, DATA, DOCUMENTS, SIGNALS, IMAGES, VIDEO, DIGITAL MEDIA CONTENT, AND AUDIO, VISUAL, AND AUDIOVISUAL MATERIALS; COMPUTER SERVICES IN THE NATURE OF CUSTOMIZED WEB PAGES FEATURING USER-DEFINED INFORMATION, PERSONAL PROFILES, AND INFORMATION; COMPUTER SERVICES, NAMELY, DESIGN, CREATION, HOSTING, AND MAINTENANCE OF ONLINE AND MOBILE APPLICATIONS FOR OTHERS FOR ORGANIZING AND CONDUCTING ONLINE MEETINGS, GATHERINGS, CONFERENCES AND INTERACTIVE DISCUSSIONS; COMPUTER SERVICES, NAMELY, DESIGN AND DEVELOPMENT OF COMPUTER SOFTWARE FOR USE IN CONNECTION WITH MOBILE APPLICATIONS, ONLINE APPLICATIONS, TELECOMMUNICATIONS APPLICATIONS, VOICE OVER INTERNET PROTOCOL (VOIP) APPLICATIONS, AND TRANSMISSION OF VOICE, MESSAGES, DATA, DOCUMENTS, SIGNALS, IMAGES, VIDEO, DIGITAL MEDIA CONTENT, AND AUDIO, VISUAL, AND AUDIOVISUAL MATERIALS; DESIGN, CREATION, HOSTING, AND MAINTENANCE OF WEBSITES FOR OTHERS FOR USE IN CONNECTION WITH COMMUNICATIONS, NAMELY, THE TRANSMISSION OF VOICE, MESSAGES, DATA, DOCUMENTS, SIGNALS, IMAGES, VIDEO, DIGITAL MEDIA CONTENT, AND AUDIO, VISUAL, AND AUDIOVISUAL MATERIALS VIA COMPUTERS, ELECTRONIC DEVICES, COMMUNICATIONS NETWORKS, INFORMATION SERVICES NETWORKS, DATA NETWORKS, LOCAL COMPUTER NETWORKS, GLOBAL COMPUTER NETWORKS, AND THE INTERNET, AND CONFERENCING, NAMELY AUDIO CONFERENCING, NETWORK CONFERENCING, TELECONFERENCING, TELEPHONE CONFERENCING, VIDEO CONFERENCING, VIDEO TELECONFERENCING, VOICE OVER INTERNET PROTOCOL (VOIP) CONFERENCING, WEB CONFERENCING; PROVIDING INFORMATION RELATING TO ONLINE NON-DOWNLOADABLE SOFTWARE TO FACILITATE ELECTRONIC COMMUNICATIONS BETWEEN INDIVIDUALS PROVIDED VIA THE INTERNET AND MOBILE DEVICES; SOFTWARE AS A SERVICE (SAAS) SERVICES FEATURING SOFTWARE FOR USE IN APPLICATION PROGRAMMING IN THE FIELD OF COMMUNICATIONS AND CONFERENCING (U.S. CLS. 100 AND 101).

MELISSA VALLILLO, EXAMINING ATTORNEY

SN 85-181,028. HAJN, LLC, FORT PIERCE, FL. FILED 11-19-2010.

My Favorite Color's Camo

THE MARK CONSISTS OF STANDARD CHARACTERS WITHOUT CLAIM TO ANY PARTICULAR FONT, STYLE, SIZE, OR COLOR.

NO CLAIM IS MADE TO THE EXCLUSIVE RIGHT TO USE "CAMO", APART FROM THE MARK AS SHOWN.

SN 85-181,626. ONBOARD SYSTEMS, INC., VANCOUVER, WA. FILED 11-19-2010.

CLASS 16—PAPER GOODS AND PRINTED MATTER

FOR BUMPER STICKERS; DECALS; DECORATIVE DECALS FOR VEHICLE WINDOWS; MAGNETIC BUMPER STICKERS; STICKERS; STICKERS AND DECALCOMANIAS (U.S. CLS. 2, 5, 22, 23, 29, 37, 38 AND 50).
FIRST USE 1-3-2011; IN COMMERCE 1-3-2011.

CLASS 25—CLOTHING

FOR A-SHIRTS; ATHLETIC APPAREL, NAMELY, SHIRTS, PANTS, JACKETS, FOOTWEAR, HATS AND CAPS, ATHLETIC UNIFORMS; BODY SHIRTS; CAMOUFLAGE JACKETS; CAMOUFLAGE PANTS; CAMOUFLAGE SHIRTS; CAMOUFLAGE VESTS; CAMP SHIRTS; CAPS; CAPS WITH VISORS; GYM PANTS; HUNTING PANTS; PANTS; SPORTS PANTS; SWEAT PANTS; SWEAT SHIRTS; SWEAT SHORTS; T-SHIRTS; TEE SHIRTS (U.S. CLS. 22 AND 39).
FIRST USE 1-3-2011; IN COMMERCE 1-3-2011.

MIDGE BUTLER, EXAMINING ATTORNEY

SN 85-181,467. STROUD CONSULTING LIMITED, BERKSHIRE SL6 6PT, UNITED KINGDOM, FILED 11-19-2010.



UNLEASHING POTENTIAL

PRIORITY CLAIMED UNDER SEC. 44(D) ON ERPNTY TM OFC APPLICATION NO. 009133521, FILED 5-26-2010, REG. NO. 009133521, DATED 11-8-2010, EXPIRES 5-26-2020.

THE MARK CONSISTS OF "STROUD" IN LIGHT, BOLD LETTERS TO THE RIGHT OF A LIGHTER BROKEN, STYLIZED BOX WITH A DARK CENTER. ALL SUPERIMPOSED ON A DARK RECTANGLE WITH A LIGHT BORDER AND THEN A DARK BORDER, WHICH IS ALL ABOVE THE WORDS "UNLEASHING POTENTIAL".

CLASS 16—PAPER GOODS AND PRINTED MATTER

FOR PRINTED NEWSLETTERS AND REPORTS IN THE FIELDS OF BUSINESS MANAGEMENT AND BUSINESS INFORMATION (U.S. CLS. 2, 5, 22, 23, 29, 37, 38 AND 50).

CLASS 35—ADVERTISING AND BUSINESS

FOR BUSINESS MANAGEMENT ASSISTANCE, INFORMATION AND CONSULTATION SERVICES (U.S. CLS. 100, 101 AND 102).

CHARLES L. JENKINS, EXAMINING ATTORNEY

LIFT WITH CONFIDENCE

THE MARK CONSISTS OF STANDARD CHARACTERS WITHOUT CLAIM TO ANY PARTICULAR FONT, STYLE, SIZE, OR COLOR.

CLASS 6—METAL GOODS

FOR METAL HOOKS HAVING POLYMER FITTINGS, PROTECTIVE METAL CAGES, AND POLYMER-COATED METAL CABLES FOR USE IN HELICOPTER CARGO LIFTING, AND OWNER'S MANUALS AND SERVICE MANUALS SOLD AS A UNIT THEREWITH, AND REPLACEMENT PARTS THEREFORE (U.S. CLS. 2, 12, 13, 14, 23, 25 AND 50).
FIRST USE 12-31-2005; IN COMMERCE 12-31-2005.

CLASS 9—ELECTRICAL AND SCIENTIFIC APPARATUS

FOR APPARATUS AND INSTRUMENTS FOR MEASURING FLOW, NAMELY, FLOW METERS FOR AERIAL MEASUREMENT OF AGRICULTURAL CHEMICALS, AND OWNER'S MANUALS AND SERVICE MANUALS SOLD AS A UNIT THEREWITH, AND REPLACEMENT PARTS THEREFOR; APPARATUS AND INSTRUMENTS FOR MEASURING WEIGHT, AND OWNER'S MANUALS AND SERVICE MANUALS SOLD AS A UNIT THEREWITH; AND DATA CARDS, NAMELY, BLANK DIGITAL MEMORY CARDS, DATA CARD READERS, NAMELY, DIGITAL MEMORY CARD READERS, AND PRINTERS (U.S. CLS. 21, 23, 26, 36 AND 38).

FIRST USE 12-31-2005; IN COMMERCE 12-31-2005.
PATRICIA EVANKO, EXAMINING ATTORNEY

SN 85-181,630. ONBOARD SYSTEMS, INC., VANCOUVER, WA. FILED 11-19-2010.



NO CLAIM IS MADE TO THE EXCLUSIVE RIGHT TO USE "SYSTEMS", APART FROM THE MARK AS SHOWN.

THE MARK CONSISTS OF A CIRCULAR DESIGN ABOVE THE WORDS "ONBOARD SYSTEMS".

SEC. 2(F) AS TO "ONBOARD SYSTEMS".

CLASS 6—METAL GOODS

FOR METAL HOOKS HAVING POLYMER FITTINGS, PROTECTIVE METAL CAGES, AND POLYMER-COATED METAL CABLES FOR USE IN HELICOPTER CARGO LIFTING, AND OWNER'S MANUALS AND SERVICE MANUALS SOLD AS A UNIT THEREWITH, AND REPLACEMENT PARTS THEREFORE (U.S. CLS. 2, 12, 13, 14, 23, 25 AND 50).

FIRST USE 12-31-1996; IN COMMERCE 12-31-1996.

CLASS 9—ELECTRICAL AND SCIENTIFIC APPARATUS

FOR APPARATUS AND INSTRUMENTS FOR MEASURING FLOW, NAMELY, FLOW METERS FOR AERIAL MEASUREMENT OF AGRICULTURAL CHEMICALS, AND OWNER'S MANUALS AND SERVICE MANUALS SOLD AS A UNIT THEREWITH, AND REPLACEMENT PARTS THEREFOR; APPARATUS AND INSTRUMENTS FOR MEASURING WEIGHT, AND OWNER'S MANUALS AND SERVICE MANUALS SOLD AS A UNIT THEREWITH; AND DATA CARDS, NAMELY, BLANK DIGITAL MEMORY CARDS, DATA CARD READERS, NAMELY, DIGITAL MEMORY CARD READERS, AND PRINTERS (U.S. CLS. 21, 23, 26, 36 AND 38).

FIRST USE 12-31-1996; IN COMMERCE 12-31-1996.
PATRICIA EVANKO, EXAMINING ATTORNEY

SN 85-181,725. SPICY SENSE INC, AKA SPICY SENSE INC, LOS ANGELES, CA. FILED 11-19-2010.



THE COLOR(S) BROWN AND BLUE IS/ARE CLAIMED AS A FEATURE OF THE MARK.

THE MARK CONSISTS OF THE BLUE WORDS "MR. CHEF" WITH A BLUE CHEF'S HAT EMERGING FROM THE LETTER "C", WITH A BROWN LINE THROUGH THE MIDDLE AND EMERGING FROM THE SIDES OF THE HAT.

CLASS 29—MEATS AND PROCESSED FOODS

FOR CANNED FOOD, NAMELY, CANNED FRUITS, CANNED VEGETABLES, CANNED CORN, PROCESSED CANNED COCOANUT, CANNED FISH, CANNED TUNA FISH, CANNED SALMON, CANNED SOUP, CANNED BEANS, TINNED OLIVES, PICKLES, JAM, PEANUT BUTTER, FRUIT PRESERVES, MARMALADE; CUT OR CANNED FRUIT SPECIFICALLY PEACHES, MANGO, PINEAPPLE, APPLE AND TROPICAL FRUIT (U.S. CL. 46).

CLASS 30—STAPLE FOODS

FOR RICE, JASMINE RICE, SUSHI RICE, BROWN RICE; CANNED SPAGHETTI; NOODLES; SPAGHETTI; MACARONI; EDIBLE SPICES (U.S. CL. 46).

KIMBERLY PERRY, EXAMINING ATTORNEY

SN 85-182,590. SALT LIFE HOLDINGS, LLC, JACKSONVILLE, FL. FILED 11-22-2010.

SALT LIFE

THE MARK CONSISTS OF STANDARD CHARACTERS WITHOUT CLAIM TO ANY PARTICULAR FONT, STYLE, SIZE, OR COLOR.

OWNER OF U.S. REG. NOS. 3,001,343, 3,843,123 AND OTHERS.

CLASS 9—ELECTRICAL AND SCIENTIFIC APPARATUS

FOR COMPUTER GAME DISCS; COMPUTER GAME SOFTWARE FOR PERSONAL COMPUTERS AND HOME VIDEO GAME CONSOLES; DOWNLOADABLE COMPUTER GAME PROGRAMS (U.S. CLS. 21, 23, 26, 36 AND 38).

CLASS 28—TOYS AND SPORTING GOODS

FOR CHILDREN'S, INFANT'S AND TODDLER'S TOYS, GAMES AND PLAYTHINGS, NAMELY, PLUSH TOYS, DOLLS, ACTION FIGURE TOYS, MINIATURE VEHICLES, AND MANIPULATIVE GAMES; WATER-PROOF BAGS ESPECIALLY ADAPTED FOR SPORTS EQUIPMENT; DIVE BAGS ESPECIALLY ADAPTED FOR SPORTS EQUIPMENT; DIVING EQUIPMENT BAGS ESPECIALLY ADAPTED FOR SPORTS EQUIPMENT; FISHING EQUIPMENT BAGS ESPECIALLY ADAPTED FOR SPORTS EQUIPMENT; FISHING EQUIPMENT, NAMELY, INSULATED FISH STORAGE BAGS; POLE SPEARS FOR USE IN FISHING; SPEAR GUNS FOR USE IN FISHING; SCUBA FINS; DIVE FINS; SWIM FINS (U.S. CLS. 22, 23, 38 AND 50).

APRIL HESIK, EXAMINING ATTORNEY

SN 85-183,133. THE HARTZ MOUNTAIN CORPORATION, SECAUCUS, NJ. FILED 11-23-2010.

REVO

THE MARK CONSISTS OF STANDARD CHARACTERS WITHOUT CLAIM TO ANY PARTICULAR FONT, STYLE, SIZE, OR COLOR.

CLASS 3—COSMETICS AND CLEANING PREPARATIONS

FOR NON-MEDICATED PET SHAMPOOS AND CONDITIONERS; DEODORANT SPRAYS FOR PETS (U.S. CLS. 1, 4, 6, 50, 51 AND 52).

CLASS 5—PHARMACEUTICALS

FOR FLEA AND TICK ERADICATION PREPARATIONS FOR ANIMALS; NAMELY, DROPS, SPRAYS, SHAMPOOS AND COLLARS (U.S. CLS. 6, 18, 44, 46, 51 AND 52).

CLASS 8—HAND TOOLS

FOR GROOMING TOOLS FOR PETS, NAMELY, NAIL TRIMMERS AND NAIL FILES (U.S. CLS. 23, 28 AND 44).

CLASS 18—LEATHER GOODS

FOR RAWHIDE CHEWS FOR DOGS; PET ACCESSORIES, NAMELY, DOG LEASHES AND PET COLLARS (U.S. CLS. 1, 2, 3, 22 AND 41).

CLASS 21—HOUSEWARES AND GLASS

FOR GROOMING TOOLS FOR PETS, NAMELY, BRUSHES, COMBS AND PET COMBING RAKE UTENSILS (U.S. CLS. 2, 13, 23, 29, 30, 33, 40 AND 50).

CLASS 28—TOYS AND SPORTING GOODS

FOR PET TOYS (U.S. CLS. 22, 23, 38 AND 50).

CLASS 31—NATURAL AGRICULTURAL PRODUCTS

FOR PET TREATS, BIRD FOOD, SMALL ANIMAL FOOD, FOOD FOR FISH (U.S. CLS. 1 AND 46).
JOHN DWYER, EXAMINING ATTORNEY

SN 85-185,867. KELLY SLATER WAVE COMPANY, LLC,
LOS ANGELES, CA. FILED 11-29-2010.

Kelly Slater Surf Park

THE MARK CONSISTS OF STANDARD CHARACTERS WITHOUT CLAIM TO ANY PARTICULAR FONT, STYLE, SIZE, OR COLOR.

OWNER OF U.S. REG. NO. 2,767,708.

NO CLAIM IS MADE TO THE EXCLUSIVE RIGHT TO USE "SURF PARK", APART FROM THE MARK AS SHOWN.

THE NAME "KELLY SLATER" IDENTIFIES A LIVING INDIVIDUAL WHOSE CONSENT IS OF RECORD.

CLASS 25—CLOTHING

FOR APPAREL, NAMELY, POLO-SHIRTS, BUTTON-DOWN SHIRTS, JERSEYS, T-SHIRTS, SHORTS, PANTS; HEADGEAR, NAMELY, HATS AND CAPS; FOOTWEAR, NAMELY, SANDALS, THONGS, CASUAL SHOES, ATHLETIC SHOES; OUTERWEAR, NAMELY, VESTS, JACKETS, WIND COATS, HOODED SWEAT SHIRTS, SWEAT SHIRTS; WETSUITS; SWIM TRUNKS (U.S. CLS. 22 AND 39).

CLASS 41—EDUCATION AND ENTERTAINMENT

FOR AMUSEMENT PARKS; ENTERTAINMENT SERVICES IN THE NATURE OF A WATER PARK AND AMUSEMENT CENTER; ENTERTAINMENT SERVICES IN THE NATURE OF AN AMUSEMENT RIDE FOR SURFING, BODY BOARDING, INTER-TUBING, KAYAKING, BODY SURFING AND WAKE BOARDING; ENTERTAINMENT IN THE NATURE OF SURFING, BODY SURFING, BODY BOARDING, AND SWIMMING SPORTING COMPETITIONS AND EXHIBITIONS, ORGANIZATION OF WATERSPORTS AND SPORT COMPETITIONS (U.S. CLS. 100, 101 AND 107).

TRACY FLETCHER, EXAMINING ATTORNEY

SN 85-186,277. DR. GREGORY BEROZA, NEW YORK, NY.
FILED 11-29-2010.

TALKING HORSES

THE MARK CONSISTS OF STANDARD CHARACTERS WITHOUT CLAIM TO ANY PARTICULAR FONT, STYLE, SIZE, OR COLOR.

OWNER OF U.S. REG. NO. 3,820,024.

NO CLAIM IS MADE TO THE EXCLUSIVE RIGHT TO USE "HORSES", APART FROM THE MARK AS SHOWN.

CLASS 16—PAPER GOODS AND PRINTED MATTER

FOR MAGAZINES RELATING TO EQUESTRIAN AND VETERINARY TOPICS (U.S. CLS. 2, 5, 22, 23, 29, 37, 38 AND 50).

CLASS 35—ADVERTISING AND BUSINESS

FOR PROVIDING MEDIA AND MARKETING CONSULTING SERVICES CONCERNING EQUESTRIAN AND VETERINARY PRODUCTS (U.S. CLS. 100, 101 AND 102).

CLASS 38—COMMUNICATION

FOR STREAMING OF AUDIO, VISUAL AND AUDIO-VISUAL MATERIAL ON THE INTERNET CONCERNING EQUESTRIAN AND/OR VETERINARY RELATED TOPICS (U.S. CLS. 100, 101 AND 104).

CLASS 41—EDUCATION AND ENTERTAINMENT

FOR ENTERTAINMENT SERVICES IN THE NATURE OF AN ON-GOING SPECIAL VARIETY, NEWS, MUSIC OR COMEDY SHOW FEATURING EQUESTRIAN AND/OR VETERINARY TOPICS BROADCAST OVER TELEVISION, SATELLITE, AUDIO, OR VIDEO MEDIA; ENTERTAINMENT SERVICES, NAMELY, PRODUCTION, PRESENTATION AND DISTRIBUTION OF CINEMA, TELEVISION OR RADIO PROGRAMS FEATURING EQUESTRIAN AND VETERINARY RELATED TOPICS; PROVIDING A COLUMN DISTRIBUTED OVER THE INTERNET CONCERNING EQUESTRIAN AND VETERINARY TOPICS (U.S. CLS. 100, 101 AND 107).

CLASS 44—MEDICAL, BEAUTY AND AGRICULTURAL SERVICES

FOR PROVIDING INFORMATION CONCERNING VETERINARY TOPICS OVER THE INTERNET (U.S. CLS. 100 AND 101).

JOHN WILKE, EXAMINING ATTORNEY

SN 85-186,569. STUDENT/SPONSOR PARTNERSHIP, INC.,
NEW YORK, NY. FILED 11-29-2010.

SSP

THE MARK CONSISTS OF STANDARD CHARACTERS WITHOUT CLAIM TO ANY PARTICULAR FONT, STYLE, SIZE, OR COLOR.

CLASS 36—INSURANCE AND FINANCIAL

FOR PROVIDING EDUCATIONAL SCHOLARSHIPS TO HIGH SCHOOL YOUTHS (U.S. CLS. 100, 101 AND 102).

FIRST USE 0-0-2001; IN COMMERCE 0-0-2001.

CLASS 41—EDUCATION AND ENTERTAINMENT

FOR PROVIDING PERSONAL GUIDANCE TO HIGH SCHOOL YOUTHS, NAMELY, EDUCATIONAL MENTORING IN THE FIELDS OF ACADEMICS AND COLLEGE ADMISSION (U.S. CLS. 100, 101 AND 107).

FIRST USE 0-0-2001; IN COMMERCE 0-0-2001.

WENDY GOODMAN, EXAMINING ATTORNEY

SN 85-186,910. THE MCGRAW-HILL COMPANIES, INC.,
NEW YORK, NY. FILED 11-30-2010.



NO CLAIM IS MADE TO THE EXCLUSIVE RIGHT TO USE "SCIENCE", APART FROM THE MARK AS SHOWN.

THE MARK CONSISTS OF THE TERM "INSTANT" ABOVE THE TERM "SCIENCE" WITH UPPERCASE LETTERS IN BOTH TERMS EXCEPT FOR THE LETTER "I" IN "SCIENCE". A STYLIZED DRAWING OF ATOMIC PARTICLES IN ORBIT IS POSITIONED TO THE RIGHT OF THE TERM "INSTANT" AND IS ABOVE THE TERM "SCIENCE".

CLASS 9—ELECTRICAL AND SCIENTIFIC APPARATUS

FOR DOWNLOADABLE COMPUTER SOFTWARE, E-BOOKS RECORDED ON COMPUTER MEDIA, AND MP3 FILES CONTAINING EDUCATIONAL MATERIALS IN THE FIELD OF SCIENCE FOR GRADES K - 6 (U.S. CLS. 21, 23, 26, 36 AND 38).

CLASS 16—PAPER GOODS AND PRINTED MATTER

FOR STUDENT WORKBOOKS IN THE FIELD OF SCIENCE FOR GRADES 2 - 6 (U.S. CLS. 2, 5, 22, 23, 29, 37, 38 AND 50).

CLASS 41—EDUCATION AND ENTERTAINMENT

FOR EDUCATIONAL SERVICES, NAMELY, PROVIDING NON-DOWNLOADABLE EDUCATIONAL COMPUTER GAMES, VIDEOS, SONGS, ANIMATIONS, FLASH PRESENTATIONS, TEXT, TESTS, AND ASSESSMENTS IN THE FIELD OF SCIENCE FOR GRADES K - 6 (U.S. CLS. 100, 101 AND 107).

CLASS 42—SCIENTIFIC AND COMPUTER SERVICES

FOR PROVIDING TEMPORARY USE OF ON-LINE NON-DOWNLOADABLE EDUCATIONAL SOFTWARE FOR TEACHING SCIENCE FOR GRADES K - 6 (U.S. CLS. 100 AND 101).

SOPHIA S. KIM, EXAMINING ATTORNEY

SN 85-187,465. WORLD TRIATHLON CORPORATION, TAMPA, FL. FILED 11-30-2010.

IRONMAN

THE MARK CONSISTS OF STANDARD CHARACTERS WITHOUT CLAIM TO ANY PARTICULAR FONT, STYLE, SIZE, OR COLOR.

OWNER OF U.S. REG. NOS. 2,022,721, 2,911,298 AND OTHERS.

CLASS 20—FURNITURE AND ARTICLES NOT OTHERWISE CLASSIFIED

FOR SLEEP PRODUCTS, NAMELY, MATTRESSES, MATTRESS FOUNDATIONS AND PILLOWS (U.S. CLS. 2, 13, 22, 25, 32 AND 50).

FIRST USE 4-17-2007; IN COMMERCE 8-1-2007.

CLASS 24—FABRICS

FOR MATTRESS COVERS AND PADS, BED SHEETS, FITTED BED SHEET COVERS, BED FLAT SHEETS AND PILLOW CASES (U.S. CLS. 42 AND 50).

FIRST USE 4-17-2007; IN COMMERCE 8-1-2007.

RONALD DELGIZZI, EXAMINING ATTORNEY

SN 85-189,452. CISCO COMPANIES, THE, INDIANAPOLIS, IN. FILED 12-2-2010.



THE COLOR(S) BLUE IS/ARE CLAIMED AS A FEATURE OF THE MARK.

THE MARK CONSISTS OF THE WORD "POND" AND A SUBSCRIPT "2" AND THE LETTER "O" WHICH IS STYLIZED SO THAT IT HAS THE APPEARANCE OF A CIRCLE SURROUNDING A WATER DROPLET. ALL LETTERS AND NUMERALS ARE IN THE COLOR BLUE. THE COLOR WHITE ONLY APPEARS AS BACKGROUND SHADING AND IS NOT PART OF THE MARK.

CLASS 2—PAINTS

FOR DYES FOR COMMERCIAL AND RESIDENTIAL RETENTION PONDS AND FARM PONDS (U.S. CLS. 6, 11 AND 16).

CLASS 3—COSMETICS AND CLEANING PREPARATIONS

FOR CHEMICAL CLEANERS FOR USE IN COMMERCIAL AND RESIDENTIAL RETENTION PONDS AND FARM PONDS (U.S. CLS. 1, 4, 6, 50, 51 AND 52).

JAY FLOWERS, EXAMINING ATTORNEY

SN 85-192,075. PREDOC, INC., PHOENIXVILLE, PA. FILED 12-7-2010.



THE COLOR(S) BLUE, GOLD, WHITE AND BLACK IS/ARE CLAIMED AS A FEATURE OF THE MARK.

THE MARK CONSISTS OF THE FOLLOWING: A BLUE CYLINDER EDGED WITH BLACK LINING WITH THE WORDS "PREDOC" IN GOLD INSIDE THE CYLINDER WITH WHITE SHADOWING BEHIND THE WORDING "PREDOC".

CLASS 37—CONSTRUCTION AND REPAIR

FOR INSTALLATION AND MAINTENANCE OF SEPTIC FIELDS AND SYSTEMS (U.S. CLS. 100, 103 AND 106).

FIRST USE 12-7-2001; IN COMMERCE 12-7-2001.

CLASS 41—EDUCATION AND ENTERTAINMENT

FOR TRAINING SERVICES IN THE FIELD OF SEPTIC SYSTEM MAINTENANCE AND MANAGEMENT (U.S. CLS. 100, 101 AND 107).

FIRST USE 12-7-2001; IN COMMERCE 12-7-2001.

KATINA MISTER, EXAMINING ATTORNEY

SN 85-192,541. PINNACLE FOODS GROUP LLC, MOUNTAIN LAKES, NJ. FILED 12-7-2010.

FARMER'S GARDEN

THE MARK CONSISTS OF STANDARD CHARACTERS WITHOUT CLAIM TO ANY PARTICULAR FONT, STYLE, SIZE, OR COLOR.

CLASS 29—MEATS AND PROCESSED FOODS

FOR PICKLES; PROCESSED PEPPERS; SAUERKRAUT; PICKLED VEGETABLES; PICKLED FRUIT; PROCESSED VEGETABLES; PROCESSED FRUIT (U.S. CL. 46).

CLASS 30—STAPLE FOODS

FOR RELISH (U.S. CL. 46).

SEAN CROWLEY, EXAMINING ATTORNEY

SN 85-193,612. PINNACLE FOODS GROUP LLC, MOUNTAIN LAKES, NJ. FILED 12-8-2010.

THE FARMER'S GARDEN

THE MARK CONSISTS OF STANDARD CHARACTERS WITHOUT CLAIM TO ANY PARTICULAR FONT, STYLE, SIZE, OR COLOR.

CLASS 29—MEATS AND PROCESSED FOODS

FOR PICKLES; PROCESSED PEPPERS; SAUERKRAUT; PICKLED VEGETABLES; PICKLED FRUIT; PROCESSED VEGETABLES; PROCESSED FRUIT (U.S. CL. 46).

CLASS 30—STAPLE FOODS

FOR RELISH (U.S. CL. 46).

SEAN CROWLEY, EXAMINING ATTORNEY

SN 85-193,642. ARES TRADING S.A., AUBONNE CH-1170, SWITZERLAND, FILED 12-8-2010.



OWNER OF U.S. REG. NO. 2,191,565.

THE MARK CONSISTS OF THE WORDS "CONNECTIONS FOR GROWTH" SUPERIMPOSED ON THREE HUMAN FIGURES IN SILHOUETTE WITH AN ARROW UNDERNEATH ARCING FROM LEFT TO RIGHT.

CLASS 16—PAPER GOODS AND PRINTED MATTER

FOR PRINTED PUBLICATIONS, NAMELY, NEWSLETTERS, LEAFLETS AND BROCHURES IN THE FIELD OF ENDOCRINOLOGY; PHOTOGRAPHS; PRINTED INSTRUCTIONAL AND TEACHING MATERIALS IN THE FIELD OF ENDOCRINOLOGY (U.S. CLS. 2, 5, 22, 23, 29, 37, 38 AND 50).

CLASS 41—EDUCATION AND ENTERTAINMENT

FOR EDUCATION SERVICES, NAMELY, EDUCATION IN THE FIELD OF ENDOCRINOLOGY PROVIDED ON A GLOBAL COMPUTER NETWORK PROVIDED THROUGH ONLINE SEMINARS, WORKSHOPS, CLASSES, EDUCATION IN THE FIELD OF ENDOCRINOLOGY PROVIDED THROUGH A CALL CENTER ONE ON ONE, EDUCATION IN THE FIELD OF ENDOCRINOLOGY PROVIDED THROUGH HOME VISITS BY HEALTHCARE PROFESSIONALS ONE ON ONE; PROVIDING TRAINING IN THE FIELD OF ENDOCRINOLOGY (U.S. CLS. 100, 101 AND 107).

CLASS 44—MEDICAL, BEAUTY AND AGRICULTURAL SERVICES

FOR MEDICAL SERVICES (U.S. CLS. 100 AND 101).

MATTHEW KLINE, EXAMINING ATTORNEY

SN 85-195,684. ITEMIZE LLC, AMANGASETT, NY. FILED 12-10-2010.

ITEMIZE HOME

THE MARK CONSISTS OF STANDARD CHARACTERS WITHOUT CLAIM TO ANY PARTICULAR FONT, STYLE, SIZE, OR COLOR.

CLASS 35—ADVERTISING AND BUSINESS

FOR PROVIDING ONLINE INFORMATION ABOUT PERSONAL ORGANIZING SERVICES; PROVIDING ORGANIZING SERVICES FOR INDIVIDUALS AT HOME THAT HELPS WITH TIME AND CATEGORIZATION MANAGEMENT OF DOCUMENTS USED IN PERSONAL AND HOUSEHOLD BUDGETING, SPENDING MANAGEMENT AND TAX PREPARATION; PROVIDING SUPPORT SERVICES IN THE NATURE OF TRACKING PURCHASES MADE BY THE CONSUMER AND PROVIDING INFORMATION ON GOODS AND SERVICES OF INTEREST TO THE CONSUMER BASED ON THEIR PURCHASING PROFILE; PROVIDING ONLINE INFORMATION IN THE FIELD OF PURCHASING MANAGEMENT SERVICES, NAMELY, PROVIDING DETAILED INFORMATION REGARDING THE PURCHASE AND SPENDING PATTERNS OF A CONSUMER (U.S. CLS. 100, 101 AND 102).

CLASS 36—INSURANCE AND FINANCIAL

FOR PROVIDING ONLINE INFORMATION ABOUT BUDGET PLANNING (U.S. CLS. 100, 101 AND 102).
KAREN BRACEY, EXAMINING ATTORNEY

SN 85-195,773. ARGANIA LLC, DBA SKIN QR ORGANICS, JUPITER, FL. FILED 12-10-2010.



NO CLAIM IS MADE TO THE EXCLUSIVE RIGHT TO USE "SKIN" OR "ORGANICS", APART FROM THE MARK AS SHOWN.

THE COLOR(S) GRAY/DARK GRAY AND GREEN IS/ARE CLAIMED AS A FEATURE OF THE MARK.

THE MARK CONSISTS OF GRAY/DARK GRAY WORDS "SKIN QR ORGANICS". GREEN LEAF IS A PART OF THE LETTER "Q" AS A DECORATION.

CLASS 3—COSMETICS AND CLEANING PREPARATIONS

FOR AROMATIC BODY CARE PRODUCTS, NAMELY, BODY LOTION, SHOWER GEL, CUTICLE CREAM, SHAMPOO, CONDITIONER, NON-MEDICATED LIP BALM, SOAP, BODY POLISH, BODY AND FOOT SCRUB AND NON-MEDICATED FOOT CREAM; BEAUTY CREAMS FOR BODY CARE; COSMETIC CREAMS FOR SKIN CARE; COSMETIC PREPARATIONS FOR BODY CARE; COSMETIC PREPARATIONS FOR PROTECTING THE SKIN FROM THE SUN'S RAYS; COSMETIC PREPARATIONS FOR SKIN CARE; COSMETIC PREPARATIONS FOR SKIN RENEWAL; EXFOLIANTS FOR BODY; FRAGRANCED BODY CARE PREPARATIONS, NAMELY, SKIN CREAMS, BODY BUTTERS, BODY LOTIONS; FRAGRANCED FACE CARE PREPARATIONS, NAMELY, SKIN MOISTURIZERS, SKIN LOTIONS, BODY SERUMS; LOTIONS FOR FACE AND BODY CARE; MOISTURIZING PREPARATIONS FOR THE SKIN, ALL THE AFORESAID MADE IN WHOLE OR SUBSTANTIAL PART OF ORGANIC INGREDIENTS (U.S. CLS. 1, 4, 6, 50, 51 AND 52).
FIRST USE 12-1-2009; IN COMMERCE 12-1-2009.

CLASS 10—MEDICAL APPARATUS

FOR MASSAGE APPARATUS; MASSAGING APPARATUS FOR PERSONAL USE (U.S. CLS. 26, 39 AND 44).
FIRST USE 1-1-2010; IN COMMERCE 1-1-2010.
JASON TURNER, EXAMINING ATTORNEY

SN 85-196,374. DATAPIPE, INC., JERSEY CITY, NJ. FILED 12-13-2010.

WE ARE THE ONE

THE MARK CONSISTS OF STANDARD CHARACTERS WITHOUT CLAIM TO ANY PARTICULAR FONT, STYLE, SIZE, OR COLOR.

CLASS 39—TRANSPORTATION AND STORAGE

FOR ELECTRONIC DATA STORAGE SERVICES, NAMELY, STORING ELECTRONIC DATA AT DATA CENTERS; COMPUTER SERVICES IN THE NATURE OF PROVIDING AN INTEGRATED SUITE OF DATA AND COMPUTER RELATED SERVICES, NAMELY, ELECTRONIC DATA STORAGE (U.S. CLS. 100 AND 105).

CLASS 42—SCIENTIFIC AND COMPUTER SERVICES

FOR COMPUTER SERVICES IN THE NATURE OF PROVIDING AN INTEGRATED SUITE OF DATA AND COMPUTER RELATED SERVICES, NAMELY, PROVIDING COMPUTER SECURITY CONSULTING IN THE AREA OF DATA STORAGE, ONLINE SECURITY AND INFORMATION SECURITY VULNERABILITY; PROVIDING A SECURE AND SAFE ENVIRONMENT FOR THE INFORMATION TECHNOLOGY SYSTEMS OF OTHERS, NAMELY, PROVIDING COMPUTER CO-LOCATION SERVICES IN THE NATURE OF PROVIDING FACILITIES FOR THE LOCATION OF COMPUTER SERVERS AND EQUIPMENT OF OTHERS; COMPUTER SERVICES IN THE NATURE OF MONITORING AND MANAGING COMPUTER NETWORK SYSTEMS; NETWORK SECURITY SERVICES IN THE NATURE OF COMPUTER NETWORK SECURITY SERVICES, NAMELY, RESTRICTING ACCESS TO AND BY COMPUTER NETWORKS TO AND OF UNDESIRED WEB SITES, MEDIA AND INDIVIDUALS AND FACILITIES; SECURITY MANAGEMENT SERVICES, NAMELY, COMPUTER CONSULTATION IN THE FIELD OF COMPUTER SECURITY; DISASTER RECOVERY SERVICES, NAMELY, COMPUTER DISASTER RECOVERY PLANNING AND RECOVERY OF COMPUTER DATA; SERVER MANAGEMENT SERVICES, NAMELY, HOSTING THE WEB SITES OF OTHERS ON A COMPUTER SERVER FOR A GLOBAL COMPUTER NETWORK; DATA BACKUP SERVICES, NAMELY, BACK-UP SERVICES FOR COMPUTER HARD DRIVE DATA; WEB SITE HOSTING SERVICES; COMPUTER SERVICES, NAMELY, REMOTE AND ON-SITE MANAGEMENT OF THE INFORMATION TECHNOLOGY CLOUD COMPUTING SYSTEMS OF OTHERS; TECHNICAL SUPPORT SERVICES, NAMELY, REMOTE AND ON-SITE INFRASTRUCTURE MANAGEMENT SERVICES FOR MONITORING, ADMINISTRATION AND MANAGEMENT OF PUBLIC AND PRIVATE CLOUD COMPUTING AND APPLICATION SYSTEMS; CONSULTING SERVICES IN THE FIELD OF CLOUD COMPUTING, NAMELY, CONSULTING IN CONNECTION WITH CLOUD COMPUTING APPLICATIONS AND NETWORKS; TECHNICAL CONSULTING SERVICES IN THE FIELDS OF PUBLIC AND PRIVATE CLOUD COMPUTING, NAMELY, CONSULTING SERVICES IN THE FIELD OF DESIGN, SELECTION, IMPLEMENTATION AND USE OF COMPUTER HARDWARE AND SOFTWARE SYSTEMS FOR OTHERS; TECHNICAL SUPPORT SERVICES, NAMELY,

MONITORING OF NETWORK SYSTEMS, SERVERS AND WEB AND DATABASE APPLICATIONS AND NOTIFICATION OF RELATED EVENTS AND ALERTS; PROVIDING ON-DEMAND RESOURCE ALLOCATION FOR COMPUTER SYSTEMS INCLUDING ACCESS TO VIRTUAL SERVERS AND VIRTUAL MACHINES; HOSTING THE SOFTWARE AND OTHER COMPUTER APPLICATIONS OF OTHERS ON A VIRTUAL PRIVATE AND PUBLIC SERVER; TECHNICAL SUPPORT SERVICES FOR HARDWARE, SOFTWARE AND OPERATING SYSTEMS IN THE NATURE OF MONITORING, DIAGNOSING AND PROBLEM RESOLUTION RELATED TO SOFTWARE APPLICATIONS; COMPUTER SERVICES, NAMELY, REMOTE AND ON-SITE MANAGEMENT OF ELECTRONIC MESSAGING SYSTEMS OF OTHERS INCLUDING TROUBLESHOOTING, OPTIMIZING, PATCHING, HARDENING, STORAGE MANAGEMENT, MAILBOX MOVEMENT, INSTALLATION AND CONFIGURATION AND MIGRATION OF ELECTRONIC MESSAGES AND MESSAGE SYSTEMS, SUCH AS E-MAIL (U.S. CLS. 100 AND 101).

ELIZABETH KAJUBI, EXAMINING ATTORNEY

CLASS 24—FABRICS

FOR FLAME RETARDANT FABRICS FOR USE IN THE MANUFACTURE OF GARMENTS, BAGS, JACKETS, GLOVES, UNIFORMS, BEDDING AND APPAREL; HEAT-STABLE TEXTILE FABRICS FOR USE IN THE MANUFACTURE OF GARMENTS, BAGS, JACKETS, GLOVES, UNIFORMS, BEDDING AND APPAREL; RAYON FABRIC; COTTON FABRICS; BROCADES; FABRICS FOR TEXTILE USE; TEXTILE FABRICS FOR USE IN THE MANUFACTURE OF GARMENTS, BAGS, JACKETS, GLOVES, UNIFORMS, BEDDING AND APPAREL; SEMI-SYNTHETIC FIBER FABRICS; REGENERATED FIBER YARN FABRICS; SYNTHETIC FIBER FABRICS; COTTON BASE MIXED FABRICS; MIXED FIBER FABRICS; CHEMICAL FIBER BASE MIXED FIBER FABRICS; CHEMICAL FIBER FABRICS (U.S. CLS. 42 AND 50).

ANDREA K. NADELMAN, EXAMINING ATTORNEY

SN 85-198,785. OLCOTT, CARTER, MORRISTOWN, NJ. FILED 12-15-2010.

SN 85-197,025. SAMIL SPINNING CO., LTD., KYOUNGSAN-SI KYOUNGBUK, REPUBLIC OF KOREA, FILED 12-14-2010.



THE MARK CONSISTS OF A WORD "NEVURN" AND A FLAG-SHAPED DIAMOND WITH A LETTER "N" INSIDE THE DIAMOND.

THE WORD(S) "NEVURN" HAS NO MEANING IN A FOREIGN LANGUAGE.

CLASS 23—YARNS AND THREADS

FOR FIRE-RETARDANT THREAD; HEAT-STABLE YARNS AND THREADS; RAYON THREAD AND YARN; COTTON THREAD AND YARN; SPUN THREAD AND YARN; SEMI-SYNTHETIC FIBER THREAD AND YARN FOR TEXTILE USE; REGENERATED FIBER THREAD AND YARN FOR TEXTILE USE; SYNTHETIC FIBER THREAD AND YARN FOR TEXTILE USE; CHEMICAL-FIBER THREADS AND YARNS FOR TEXTILE USE; SYNTHETIC FIBER THREAD AND YARN; COTTON BASE MIXED THREAD AND YARN; WOOL BASE MIXED THREAD AND YARN; MIXED SPUN THREAD AND YARN; CHEMICAL FIBER BASE MIXED THREAD AND YARN (U.S. CL. 43).

9394

THE MARK CONSISTS OF STANDARD CHARACTERS WITHOUT CLAIM TO ANY PARTICULAR FONT, STYLE, SIZE, OR COLOR.

CLASS 25—CLOTHING

FOR APPAREL, NAMELY, ATHLETIC WEAR IN THE NATURE OF SHIRTS AND HOODED SWEATSHIRTS; BELTS; CLOTHING ACCESSORIES, NAMELY, HATS AND BANDANAS (U.S. CLS. 22 AND 39).

CLASS 26—FANCY GOODS

FOR BELT BUCKLES (U.S. CLS. 37, 39, 40, 42 AND 50). AMY KERTGATE, EXAMINING ATTORNEY

SN 85-198,923. CHU, SAMMY, IRVINE, CA. FILED 12-15-2010.

Where Visibility Matters

THE MARK CONSISTS OF STANDARD CHARACTERS WITHOUT CLAIM TO ANY PARTICULAR FONT, STYLE, SIZE, OR COLOR.

CLASS 9—ELECTRICAL AND SCIENTIFIC APPARATUS

FOR AUTOMOTIVE, INDUSTRIAL, CONSTRUCTION, LOCOMOTIVE, AVIATION, NAVIGATION AND MARINE SAFETY-WARNING LIGHTS NAMELY STROBES, ROTATING LIGHTS AND BAR LIGHTS; FLASHING AND STEADY SAFETY LIGHTS; LED AND HID LIGHT CONTROLS (U.S. CLS. 21, 23, 26, 36 AND 38).

CLASS 11—ENVIRONMENTAL CONTROL APPARATUS

SN 85-200,671. RBR, LLC, VERNON, CA. FILED 12-17-2010.

FOR BACKUP LIGHTS FOR LAND VEHICLES; HIGH INTENSITY SEARCH LIGHTS; LED (LIGHT EMITTING DIODE) LIGHTING FIXTURES; LED (LIGHT EMITTING DIODES) LIGHTING FIXTURES FOR USE IN DISPLAY, COMMERCIAL, INDUSTRIAL, RESIDENTIAL, AND ARCHITECTURAL ACCENT LIGHTING APPLICATIONS; LED AND HID LIGHT FIXTURES; LED LANDSCAPE LIGHTS; LED LIGHT ASSEMBLIES FOR STREET LIGHTS, SIGNS, COMMERCIAL LIGHTING, AUTOMOBILES, BUILDINGS, AND OTHER ARCHITECTURAL USES; LIGHT BARS FOR VEHICLES, NAMELY, OFFROAD VEHICLES; LIGHT PANELS FOR VEHICLES, NAMELY, OFFROAD VEHICLES; LIGHTS FOR ILLUMINATING STAIRS, DOORS AND OTHER PORTIONS OF BUILDINGS; LIGHTS FOR USE IN ILLUMINATING SIGNS AND DISPLAYS; LIGHTS FOR VEHICLES; LUMINAIRES, USING LIGHT EMITTING DIODES (LEDS) AS A LIGHT SOURCE, FOR STREET OR ROADWAY LIGHTING; MINIATURE ACCENT LIGHTS FOR ATTACHMENT TO THE BODY AND/OR SPORTS EQUIPMENT TO PROVIDE ACCENT LIGHTING TO PARTS OF THE BODY AND/OR THE SPORTS EQUIPMENT TO WHICH IT IS ATTACHED; MOBILE LIGHT TOWERS; OPTICAL LENS COVERS THAT IMPROVES LIGHT OUTPUT AND UNIFORMITY, AND PROTECTS THE LED SOLD AS A FEATURE OF AN LED LIGHTING SYSTEM; PORTABLE UTILITY LIGHTS; REAR LIGHTS FOR VEHICLES; RUNNING LIGHTS FOR LAND VEHICLES; SPOT LIGHTS; WALL LIGHTS (U.S. CLS. 13, 21, 23, 31 AND 34).

FLORENTINA BLANDU, EXAMINING ATTORNEY



SN 85-199,685. 100 BLACK MEN OF NEW JERSEY, INC., FREEHOLD, NJ. FILED 12-16-2010.

100 LEGACY ACADEMY CHARTER
SCHOOL

OWNER OF U.S. REG. NOS. 2,885,584, 3,339,292 AND 3,640,831.

THE MARK CONSISTS OF THE WORD "JOIE" IN STYLIZED WRITING.

THE ENGLISH TRANSLATION OF "JOIE" IN THE MARK IS "JOY".

THE MARK CONSISTS OF STANDARD CHARACTERS WITHOUT CLAIM TO ANY PARTICULAR FONT, STYLE, SIZE, OR COLOR.

NO CLAIM IS MADE TO THE EXCLUSIVE RIGHT TO USE "ACADEMY CHARTER SCHOOL", APART FROM THE MARK AS SHOWN.

CLASS 25—CLOTHING

FOR CLOTHING, NAMELY, SHIRTS, T-SHIRTS, SWEATSHIRTS, CAPS, HATS, SHORTS, PANTS, AND JACKETS (U.S. CLS. 22 AND 39).

CLASS 41—EDUCATION AND ENTERTAINMENT

FOR EDUCATIONAL SERVICES IN THE NATURE OF CHARTER SCHOOLS PROVIDING SECONDARY SCHOOL EDUCATION (U.S. CLS. 100, 101 AND 107).

BRIAN NEVILLE, EXAMINING ATTORNEY

CLASS 9—ELECTRICAL AND SCIENTIFIC APPARATUS

FOR SUNGLASSES AND CASES THEREFOR; MOBILE PHONES AND CASES THEREFOR (U.S. CLS. 21, 23, 26, 36 AND 38).

CLASS 25—CLOTHING

FOR CLOTHES, NAMELY, JEANS, PANTS, CAPRI PANTS, SHIRTS, JACKETS, T-SHIRTS, DRESSES, JUMPERS, SWEATERS, CARDIGANS, SKIRTS, SWEATSHIRTS, SWEATPANTS, BLOUSES, TUNICS, GOWNS, SHIRT-DRESSES, SHORTS, SLACKS, JUMPSUITS, BLAZERS, COATS AND VESTS; FOOTWEAR, NAMELY, BOOTS, SANDALS, PUMPS, WEDGES AND FLATS; SKORTS; ROMPERS; SCARVES; HEADWEAR, NAMELY, HATS AND BONNETS; UNDERWEAR AND SLEEPWEAR, NAMELY, BRAS, PAJAMAS, BODYSUITS, LEOTARDS, CAMISOLES, SLIPS, ROBES AND CORSETS; SOCKS; NECKTIES; SWIMWEAR, NAMELY, SWIMSUITS, SWIMSUIT COVER-UPS AND WRAPS; BELTS; SHAWLS; GLOVES; FOOTWEAR, NAMELY, PLATFORMS, STILETTOS, FLIP-FLOPS AND SLIPPERS (U.S. CLS. 22 AND 39).

FIRST USE 8-0-2001; IN COMMERCE 8-0-2001.

MATTHEW MCDOWELL, EXAMINING ATTORNEY

SN 85-200,760. OLCOTT, CARTER, MORRISTOWN, NJ.
FILED 12-17-2010.

SN 85-200,954. TRAVELCLICK, INC., SCHAUMBURG, IL.
FILED 12-17-2010.



THE MARK CONSISTS OF A STYLIZED SKULL OUTLINE WITH THE NUMBER "9394" APPEARING IN PLACE OF THE SKULL'S MOUTH.

CLASS 25—CLOTHING

FOR APPAREL, NAMELY, ATHLETIC WEAR IN THE NATURE OF SHIRTS AND HOODED SWEATSHIRTS; BELTS; CLOTHING ACCESSORIES, NAMELY, HATS AND BANDANAS (U.S. CLS. 22 AND 39).

CLASS 26—FANCY GOODS

FOR BELT BUCKLES (U.S. CLS. 37, 39, 40, 42 AND 50).
AMY KERTGATE, EXAMINING ATTORNEY

SN 85-200,799. B.S.J.Z., LLC, NEW YORK, NY. FILED 12-17-2010.

OFF THE WALL

THE MARK CONSISTS OF STANDARD CHARACTERS WITHOUT CLAIM TO ANY PARTICULAR FONT, STYLE, SIZE, OR COLOR.

CLASS 30—STAPLE FOODS

FOR FROZEN YOGURT AND FROZEN DESSERTS CONSISTING OF CAKES FORMED FROM FROZEN YOGURTS WITH TOPPINGS AND YOGURT FREEZER POPS (U.S. CL. 46).

CLASS 35—ADVERTISING AND BUSINESS

FOR RETAIL STORE SERVICES FEATURING FROZEN YOGURT AND OTHER FROZEN CONFECTIONS, FOR CONSUMPTION ON AND OFF THE PREMISES (U.S. CLS. 100, 101 AND 102).
ANTHONY RINKER, EXAMINING ATTORNEY

GUESTVIEW360

THE MARK CONSISTS OF STANDARD CHARACTERS WITHOUT CLAIM TO ANY PARTICULAR FONT, STYLE, SIZE, OR COLOR.

CLASS 35—ADVERTISING AND BUSINESS

FOR PROVIDING BUSINESS AND MARKETING INFORMATION ABOUT CUSTOMERS AND PROSPECTIVE CUSTOMERS IN THE FIELDS OF HOTELS AND TRAVEL VIA A GLOBAL COMPUTER NETWORK; COLLECTION, PREPARATION, COMPOSITION, ACQUISITION AND PROVISION OF CUSTOMER AND PROSPECTIVE CUSTOMER INFORMATION, DATA, STATISTICS AND INDICES IN CONNECTION WITH HOTELS AND THE HOTEL AND TRAVEL INDUSTRIES (U.S. CLS. 100, 101 AND 102).

CLASS 39—TRANSPORTATION AND STORAGE

FOR ELECTRONIC STORAGE OF INFORMATION AND DATA IN CONNECTION WITH HOTELS AND THE HOTEL AND TRAVEL INDUSTRIES (U.S. CLS. 100 AND 105).

WENDY JUN, EXAMINING ATTORNEY

SN 85-201,379. BRIGHTMESH INC., TORONTO, ONTARIO, CANADA, FILED 12-19-2010.

THE KNOWLEDGE NETWORK

THE MARK CONSISTS OF STANDARD CHARACTERS WITHOUT CLAIM TO ANY PARTICULAR FONT, STYLE, SIZE, OR COLOR.

NO CLAIM IS MADE TO THE EXCLUSIVE RIGHT TO USE "NETWORK", APART FROM THE MARK AS SHOWN.

CLASS 35—ADVERTISING AND BUSINESS

FOR ONLINE EMPLOYMENT AND RECRUITING SERVICES, NAMELY, ONLINE DATABASES FEATURING INFORMATION RELATING TO EMPLOYERS AND EMPLOYEES AND PLACES OF EMPLOYMENT; NETWORKING SERVICES PROVIDED VIA THE INTERNET, NAMELY, ONLINE CAREER NETWORKING SERVICES (U.S. CLS. 100, 101 AND 102).

CLASS 45—PERSONAL AND LEGAL SERVICES

FOR ONLINE SOCIAL NETWORKING SERVICES (U.S. CLS. 100 AND 101).
FLORENTINA BLANDU, EXAMINING ATTORNEY

SN 85-204,041. ANGELS GATE WINERY LIMITED, BEAMSVILLE, ONTARIO, CANADA, FILED 12-22-2010.

ANGELS GATE

THE MARK CONSISTS OF STANDARD CHARACTERS WITHOUT CLAIM TO ANY PARTICULAR FONT, STYLE, SIZE, OR COLOR.

OWNER OF CANADA REG. NO. TMA642428, DATED 6-17-2005, EXPIRES 6-17-2015.

CLASS 33—WINES AND SPIRITS

FOR WINE (U.S. CLS. 47 AND 49).

CLASS 35—ADVERTISING AND BUSINESS

FOR WINERY RELATED SERVICES, NAMELY, WHOLESALE DISTRIBUTORSHIPS AND RETAIL STORE SERVICES FEATURING WINE (U.S. CLS. 100, 101 AND 102).

CLASS 41—EDUCATION AND ENTERTAINMENT

FOR CONDUCTING GUIDED TOURS OF WINERIES; ENTERTAINMENT SERVICES, NAMELY, WINE TASTINGS (U.S. CLS. 100, 101 AND 107).

CLASS 43—HOTEL AND RESTAURANT SERVICES

FOR RESTAURANT SERVICES, PROVIDING BANQUET AND SOCIAL FUNCTION FACILITIES FOR SPECIAL OCCASIONS (U.S. CLS. 100 AND 101).

CLASS 44—MEDICAL, BEAUTY AND AGRICULTURAL SERVICES

FOR VITICULTURE SERVICES, NAMELY, GRAPE GROWING AND CULTIVATION OF GRAPES FOR OTHERS; VITICULTURE CONSULTATION SERVICES IN THE FIELDS OF GRAPE GROWING AND THE CULTIVATION OF GRAPES (U.S. CLS. 100 AND 101).

RONALD AIKENS, EXAMINING ATTORNEY

SN 85-204,145. ALTERNATIVES UNLIMITED INC., CALGARY, ALBERTA, CANADA, FILED 12-22-2010.

TELESCOUT

THE MARK CONSISTS OF STANDARD CHARACTERS WITHOUT CLAIM TO ANY PARTICULAR FONT, STYLE, SIZE, OR COLOR.

OWNER OF CANADA REG. NO. 768086, DATED 5-28-2010, EXPIRES 5-28-2025.

CLASS 16—PAPER GOODS AND PRINTED MATTER

FOR MANUALS FOR USE IN TEACHING TELEPHONE PROSPECTING OF POTENTIAL CUSTOMERS (U.S. CLS. 2, 5, 22, 23, 29, 37, 38 AND 50).

CLASS 35—ADVERTISING AND BUSINESS

FOR SURVEYS OF BUSINESSES RELATING TO GOODS AND SERVICES THEIR BUSINESSES REQUIRE, BUSINESS-TO-BUSINESS SALES PROSPECTING, LEAD GENERATION AND RELATIONSHIP NURTURING; TELEPHONE PROSPECTING FOR PROSPECTIVE CUSTOMERS OF GOODS AND SERVICES RELEVANT TO BUSINESSES; TELEPHONE PROSPECTING FOR CUSTOMERS OF CONSUMER GOODS; SURVEYS OF INDIVIDUALS RELATING TO GOODS AND SERVICES RELEVANT TO THEIR PERSONAL USE (U.S. CLS. 100, 101 AND 102).

ANNE MADDEN, EXAMINING ATTORNEY

SN 85-205,227. THE DOUGLAS FOUNDATION, BEVERLY HILLS, CA. FILED 12-23-2010.



OWNER OF U.S. REG. NO. 2,535,572.

THE NAME(S), PORTRAIT(S), AND/OR SIGNATURE(S) SHOWN IN THE MARK IDENTIFIES "KIRK DOUGLAS", WHOSE CONSENT(S) TO REGISTER IS MADE OF RECORD.

THE MARK CONSISTS OF THE WORDS "KIRK DOUGLAS".

CLASS 35—ADVERTISING AND BUSINESS

FOR ONLINE RETAIL STORE SERVICES FEATURING BOOKS, VIDEOS, DVDS, RECORDED MOTION PICTURES AND RECORDED TELEVISION PROGRAMMING; COMMERCIAL ADMINISTRATION OF THE LICENSING TO OTHERS THE RIGHT TO USE THE NAME AND LIKENESS OF THE ACTOR KIRK DOUGLAS (U.S. CLS. 100, 101 AND 102).

FIRST USE 12-0-2009; IN COMMERCE 12-0-2009.

CLASS 41—EDUCATION AND ENTERTAINMENT

FOR ENTERTAINMENT SERVICES, NAMELY, PROVIDING A WEBSITE FEATURING NON-DOWNLOADABLE FILM CLIPS, PHOTOGRAPHS, BIOGRAPHY INFORMATION AND OTHER MULTI-MEDIA MATERIALS RELATED TO THE ACTOR KIRK DOUGLAS AND HIS CAREER; ENTERTAINMENT SERVICES, NAMELY, PROVIDING INFORMATION, NON-DOWNLOADABLE ARTICLES AND COMMENTARY ONLINE IN THE FIELD OF ACTING AND RELATED INFORMATION (U.S. CLS. 100, 101 AND 107).

FIRST USE 12-0-2009; IN COMMERCE 12-0-2009.

CLASS 45—PERSONAL AND LEGAL SERVICES

FOR LICENSING TO OTHERS THE RIGHT TO USE THE NAME AND LIKENESS OF THE ACTOR KIRK DOUGLAS (U.S. CLS. 100 AND 101).

FIRST USE 12-0-2009; IN COMMERCE 12-0-2009.

AMY HELLA, EXAMINING ATTORNEY

SN 85-205,297. YOAKUM NATIONAL BANK, YOAKUM, TX. FILED 12-23-2010.

SN 85-206,500. YOAKUM NATIONAL BANK, YOAKUM, TX. FILED 12-28-2010.

Money Mouse

THE MARK CONSISTS OF STANDARD CHARACTERS WITHOUT CLAIM TO ANY PARTICULAR FONT, STYLE, SIZE, OR COLOR.

NO CLAIM IS MADE TO THE EXCLUSIVE RIGHT TO USE "MONEY", APART FROM THE MARK AS SHOWN.

CLASS 16—PAPER GOODS AND PRINTED MATTER

FOR PRINTED POST CARDS, GIFT CARDS, COLORING BOOKS, AND QUARTERLY NEWSLETTERS IN THE FIELD OF FINANCIAL LITERACY FOR CHILDREN (U.S. CLS. 2, 5, 22, 23, 29, 37, 38 AND 50).

FIRST USE 11-1-2007; IN COMMERCE 11-1-2007.

CLASS 36—INSURANCE AND FINANCIAL

FOR BANKING AND FINANCIAL SERVICES, NAMELY, ADMINISTRATION OF CHECKING ACCOUNTS AND SAVINGS ACCOUNTS FOR THE BENEFIT OF MINORS; FINANCIAL SERVICES, NAMELY, BANKING SERVICES (U.S. CLS. 100, 101 AND 102).

FIRST USE 11-1-2007; IN COMMERCE 11-1-2007.
ROBIN CHOSID, EXAMINING ATTORNEY

SN 85-205,765. TOLUNA USA, INC., WILTON, CT. FILED 12-27-2010.

SAFEVIEW

THE MARK CONSISTS OF STANDARD CHARACTERS WITHOUT CLAIM TO ANY PARTICULAR FONT, STYLE, SIZE, OR COLOR.

CLASS 9—ELECTRICAL AND SCIENTIFIC APPARATUS

FOR DOWNLOADABLE COMPUTER SOFTWARE PROGRAM THAT PROHIBITS ONLINE MARKETING RESEARCH SURVEY RESPONDENTS FROM SAVING IMAGES, VIDEO AND AUDIO FILES LOCALLY, OR FORWARDING THEM TO THIRD PARTIES (U.S. CLS. 21, 23, 26, 36 AND 38).

CLASS 35—ADVERTISING AND BUSINESS

FOR MARKETING RESEARCH SERVICES, NAMELY, CONDUCTING ON-LINE CONSUMER MARKETING AND OPINION POLLING RESEARCH THAT ALLOWS CLIENT USERS THE ABILITY TO ENSURE SECURITY OF SENSITIVE VISUAL MEDIA, IMAGES, AUDIO AND VIDEO BY UTILIZING TECHNOLOGY THAT PROHIBITS ONLINE MARKETING RESEARCH SURVEY RESPONDENTS FROM SAVING IMAGES, VIDEO AND AUDIO FILES LOCALLY, OR FORWARDING THEM TO THIRD PARTIES (U.S. CLS. 100, 101 AND 102).

H. M. FISHER, EXAMINING ATTORNEY



NO CLAIM IS MADE TO THE EXCLUSIVE RIGHT TO USE "MONEY", APART FROM THE MARK AS SHOWN.

THE MARK CONSISTS OF THE STYLIZED WORDS, "MONEY MOUSE".

CLASS 16—PAPER GOODS AND PRINTED MATTER

FOR PRINTED POST CARDS, GIFT CARDS, COLORING BOOKS, AND QUARTERLY NEWSLETTERS IN THE FIELD OF FINANCIAL LITERACY FOR CHILDREN (U.S. CLS. 2, 5, 22, 23, 29, 37, 38 AND 50).

FIRST USE 11-1-2007; IN COMMERCE 11-1-2007.

CLASS 36—INSURANCE AND FINANCIAL

FOR BANKING AND FINANCIAL SERVICES, NAMELY, ADMINISTRATION OF CHECKING ACCOUNTS AND SAVINGS ACCOUNTS FOR THE BENEFIT OF MINORS; FINANCIAL SERVICES, NAMELY, BANKING SERVICES (U.S. CLS. 100, 101 AND 102).

FIRST USE 11-1-2007; IN COMMERCE 11-1-2007.
ROBIN CHOSID, EXAMINING ATTORNEY

SN 85-206,535. YOAKUM NATIONAL BANK, YOAKUM, TX. FILED 12-28-2010.



NO CLAIM IS MADE TO THE EXCLUSIVE RIGHT TO USE "MONEY", APART FROM THE MARK AS SHOWN.

THE MARK CONSISTS OF A DRAWING OF A MOUSE WEARING A SHORT-SLEEVED T-SHIRT WITH SEVERAL DOLLAR SIGNS AND SHORTS WITH THE WORDS "MONEY MOUSE".

CLASS 16—PAPER GOODS AND PRINTED MATTER

FOR PRINTED POST CARDS, GIFT CARDS, COLORING BOOKS, AND QUARTERLY NEWSLETTERS IN THE FIELD OF FINANCIAL LITERACY FOR CHILDREN (U.S. CLS. 2, 5, 22, 23, 29, 37, 38 AND 50).
FIRST USE 11-1-2007; IN COMMERCE 11-1-2007.

CLASS 36—INSURANCE AND FINANCIAL

FOR BANKING AND FINANCIAL SERVICES, NAMELY, ADMINISTRATION OF CHECKING ACCOUNTS AND SAVINGS ACCOUNTS FOR THE BENEFIT OF MINORS; FINANCIAL SERVICES, NAMELY, BANKING SERVICES (U.S. CLS. 100, 101 AND 102).
FIRST USE 11-1-2007; IN COMMERCE 11-1-2007.
ROBIN CHOSID, EXAMINING ATTORNEY

SN 85-206,773. COPY CAT COOK LLC, NORTH MIAMI, FL. FILED 12-28-2010.

COPY CAT COOK

THE MARK CONSISTS OF STANDARD CHARACTERS WITHOUT CLAIM TO ANY PARTICULAR FONT, STYLE, SIZE, OR COLOR.

NO CLAIM IS MADE TO THE EXCLUSIVE RIGHT TO USE "COOK", APART FROM THE MARK AS SHOWN.

CLASS 41—EDUCATION AND ENTERTAINMENT

FOR ENTERTAINMENT IN THE NATURE OF ONGOING TELEVISION PROGRAMS IN THE FIELD OF COOKING (U.S. CLS. 100, 101 AND 107).

CLASS 43—HOTEL AND RESTAURANT SERVICES

FOR PROVIDING A WEBSITE FEATURING INFORMATION ABOUT COOKING (U.S. CLS. 100 AND 101).
NATALIE POLZER, EXAMINING ATTORNEY

SN 85-207,715. TIME TO KNOW LIMITED, ST. PETER PORT, GUERNSEY, FILED 12-30-2010.

THE BLOOPS



THE MARK CONSISTS OF "THE BLOOPS" APPEARING ABOVE THREE FIGURES. THE FIGURE TO THE LEFT HAS A CIRCLE ON ITS STOMACH AND AN "I" WITHIN THE CIRCLE. THE SECOND FIGURE APPEARS WITH A JACKET, MUSTACHE, HAT, GLOVES, BELT, AND MAGNIFYING GLASS. THE THIRD FIGURE APPEARS IN DARK AND LIGHT SHADES WITH HEAD AND HANDS.

CLASS 9—ELECTRICAL AND SCIENTIFIC APPARATUS

FOR COMPUTERS; COMPUTER HARDWARE; COMPUTER SOFTWARE IN THE FIELD OF EDUCATIONAL SOFTWARE; COMPUTER PROGRAMS AND SOFTWARE FOR CREATING, PRODUCTION, EDITING AND TRANSMISSION OF VIDEOS, ALL FOR CHILDREN'S AND ADULTS' EDUCATION; COMPUTER GAME SOFTWARE, INTERACTIVE MULTIMEDIA COMPUTER GAME SOFTWARE, ALL FOR CHILDREN'S AND ADULTS' EDUCATION (U.S. CLS. 21, 23, 26, 36 AND 38).

CLASS 41—EDUCATION AND ENTERTAINMENT

FOR MULTIMEDIA ENTERTAINMENT SOFTWARE PRODUCTION SERVICES; EDUCATIONAL SOFTWARE PRODUCTION SERVICES; EDUCATION SERVICES IN THE NATURE OF CLASSES, COURSES, SEMINARS, WORKSHOPS, CONFERENCES, ONLINE CLASSES AND ONLINE COURSES, AT THE KINDERGARTEN, PRESCHOOL, ELEMENTARY, JUNIOR HIGH SCHOOL, HIGH SCHOOL, AND COLLEGE LEVELS, IN AND OUT OF A CLASSROOM; TRAINING SERVICES IN THE FIELD OF EDUCATIONAL INSTRUCTION, NAMELY, TRAINING EDUCATIONAL INSTRUCTORS ON THE USE OF MULTIMEDIA TOOLS AND EDUCATIONAL SOFTWARE (U.S. CLS. 100, 101 AND 107).
JILL PRATER, EXAMINING ATTORNEY

SN 85-207,716. TIME TO KNOW LIMITED, ST. PETER PORT, GUERNSEY, FILED 12-30-2010.

THE BLOOPSTERS



THE MARK CONSISTS OF THE TERMS "THE BLOOPSTERS" APPEARING ABOVE NINE FIGURES. THE FIGURE TO THE FARTHEST LEFT APPEARS WITH A VEST, SHIRT, PANTS AND BOWTIE, AND SPECTACLES. THE NEXT FIGURE APPEARS WITH A DRESS, ROSE AND TIGHTS, SHOES AND HEADBAND. THE NEXT FIGURE APPEARS WITH A DRESS WITH COLLAR, BOW AND SHOES. THE NEXT FIGURE APPEARS WITH A STRIPED SHIRT WITH A JACKET. THE NEXT FIGURE APPEARS WITH A SHIRT, TIE, PANTS AND GLASSES. THE NEXT FIGURE APPEARS WITH A SHIRT, JACKET AND PANTS. THE NEXT FIGURE APPEARS WITH GLASSES, SHIRT, SHOES AND PANTS. THE NEXT FIGURE APPEARS WITH BLUE VEST, SHIRT, PANTS AND CANE AND SPECTACLES. THE FINAL FIGURE ON THE RIGHT APPEARS IN LONG PAJAMAS.

CLASS 9—ELECTRICAL AND SCIENTIFIC APPARATUS

FOR COMPUTERS; COMPUTER HARDWARE; COMPUTER SOFTWARE IN THE FIELD OF EDUCATIONAL SOFTWARE; COMPUTER PROGRAMS AND SOFTWARE FOR CREATING, PRODUCTION, EDITING AND TRANSMISSION OF VIDEOS, ALL FOR CHILDREN'S AND ADULTS' EDUCATION; COMPUTER GAME SOFTWARE, INTERACTIVE MULTIMEDIA COMPUTER GAME SOFTWARE, ALL FOR CHILDREN'S AND ADULTS' EDUCATION (U.S. CLS. 21, 23, 26, 36 AND 38).

CLASS 41—EDUCATION AND ENTERTAINMENT

FOR MULTIMEDIA ENTERTAINMENT SOFTWARE PRODUCTION SERVICES; EDUCATIONAL SOFTWARE PRODUCTION SERVICES; EDUCATION SERVICES IN THE NATURE OF CLASSES, COURSES, SEMINARS, WORKSHOPS, CONFERENCES, ONLINE CLASSES AND ONLINE COURSES, AT THE KINDERGARTEN, PRESCHOOL, ELEMENTARY, JUNIOR HIGH SCHOOL, HIGH SCHOOL, AND COLLEGE LEVELS, IN AND OUT OF A CLASSROOM; TRAINING SERVICES IN THE FIELD OF EDUCATIONAL INSTRUCTION, NAMELY, TRAINING EDUCATIONAL INSTRUCTORS ON THE USE OF MULTIMEDIA TOOLS AND EDUCATIONAL SOFTWARE (U.S. CLS. 100, 101 AND 107).

JILL PRATER, EXAMINING ATTORNEY

SN 85-208,159. WARRIORS GROUP, LLC, FREDERICKSBURG, VA. FILED 12-30-2010.



NO CLAIM IS MADE TO THE EXCLUSIVE RIGHT TO USE "GROUP" AND "LLC", APART FROM THE MARK AS SHOWN.

THE COLOR(S) RED AND BLACK IS/ARE CLAIMED AS A FEATURE OF THE MARK.

THE MARK CONSISTS OF THE WORDS "WARRIORS GROUP LLC" IN BLACK BELOW A SQUARE FIELD GEOMETRIC DESIGN COMPOSED OF RED SPHERES

SN 85-207,887. NXSYSTEMS, INC., FORMERLY VIRTUAL AUTOMATED TECHNOLOGIES, INC., PORTLAND, OR. FILED 12-30-2010.

Pay Any Card

THE MARK CONSISTS OF STANDARD CHARACTERS WITHOUT CLAIM TO ANY PARTICULAR FONT, STYLE, SIZE, OR COLOR.

CLASS 9—ELECTRICAL AND SCIENTIFIC APPARATUS

FOR COMPUTER SOFTWARE FOR FINANCIAL TRANSACTIONS, NAMELY, ELECTRONIC FINANCIAL PLATFORM THAT FACILITATES TRANSFER OF MONEY FROM A FUNDING SOURCE TO A CREDIT CARD (U.S. CLS. 21, 23, 26, 36 AND 38).

CLASS 35—ADVERTISING AND BUSINESS

FOR PROVIDING AN ON-LINE COMPUTER WEBSITE THAT PROVIDES COMMERCIAL FINANCIAL TRANSACTION DATA, ACCOUNT MANAGEMENT, FINANCIAL REPORTING, AND ACCOUNTING FEATURES (U.S. CLS. 100, 101 AND 102).

CLASS 36—INSURANCE AND FINANCIAL

FOR ELECTRONIC CREDIT CARD TRANSACTIONS; ELECTRONIC BANKING VIA A GLOBAL COMPUTER NETWORK; ELECTRONIC CASH TRANSACTIONS; ELECTRONIC FUNDS TRANSFERS; FINANCIAL SERVICES, NAMELY, ELECTRONICALLY TRANSFERRING MONEY FROM A FUNDING SOURCE TO A CREDIT CARD ACCOUNT; PROVIDING ELECTRONIC PROCESSING OF CREDIT CARD TRANSACTIONS AND ELECTRONIC PAYMENTS VIA A GLOBAL COMPUTER NETWORK; PROVIDING AN ON-LINE COMPUTER WEBSITE THAT PROVIDES FINANCIAL TRANSACTION DATA AND FINANCIAL REPORTING FEATURES; AND PROVIDING ELECTRONIC PROCESSING OF ELECTRONIC FUNDS TRANSFER (U.S. CLS. 100, 101 AND 102).

DAVID ELTON, EXAMINING ATTORNEY

CLASS 16—PAPER GOODS AND PRINTED MATTER

FOR BOOKS, NAMELY BOOKS RELATED TO LEADERSHIP DEVELOPMENT IN THE FIELD OF BUSINESS MANAGEMENT (U.S. CLS. 2, 5, 22, 23, 29, 37, 38 AND 50).

CLASS 35—ADVERTISING AND BUSINESS

FOR CONSULTING SERVICES, NAMELY CONSULTING IN THE FIELD OF BUSINESS DEVELOPMENT AND MANAGEMENT (U.S. CLS. 100, 101 AND 102).

HENRY S. ZAK, EXAMINING ATTORNEY

SN 85-208,168. WARRIORS GROUP, LLC, FREDERICKSBURG, VA. FILED 12-30-2010.



NO CLAIM IS MADE TO THE EXCLUSIVE RIGHT TO USE "MANAGEMENT", APART FROM THE MARK AS SHOWN.

THE COLOR(S) RED AND BLACK IS/ARE CLAIMED AS A FEATURE OF THE MARK.

THE MARK CONSISTS OF THE WORDS "MANEUVER MANAGEMENT" IN BLACK, APPEARING TO THE RIGHT OF A PAINTED RED CIRCLE CONTAINING A CENTRAL RED PAINTED DOT.

CLASS 16—PAPER GOODS AND PRINTED MATTER

FOR BOOKS, NAMELY BOOKS RELATED TO LEADERSHIP DEVELOPMENT IN THE FIELD OF BUSINESS MANAGEMENT (U.S. CLS. 2, 5, 22, 23, 29, 37, 38 AND 50).

CLASS 35—ADVERTISING AND BUSINESS

FOR CONSULTING SERVICES, NAMELY CONSULTING IN THE FIELD OF BUSINESS DEVELOPMENT AND MANAGEMENT (U.S. CLS. 100, 101 AND 102).

HENRY S. ZAK, EXAMINING ATTORNEY

SN 85-208,629. PURE WILLIE LLC, COSTA MESA, CA. FILED 12-31-2010.

PURE WILLIE

THE MARK CONSISTS OF STANDARD CHARACTERS WITHOUT CLAIM TO ANY PARTICULAR FONT, STYLE, SIZE, OR COLOR.

CLASS 20—FURNITURE AND ARTICLES NOT OTHERWISE CLASSIFIED

FOR PACKAGING CONTAINERS OF PLASTIC (U.S. CLS. 2, 13, 22, 25, 32 AND 50).

CLASS 25—CLOTHING

FOR CLOTHING, NAMELY, T-SHIRTS, JACKETS, HOODED SWEATSHIRTS, HATS, BANDANAS, SHORTS, PANTS (U.S. CLS. 22 AND 39).
LIEF MARTIN, EXAMINING ATTORNEY

SN 85-209,195. LAUREN, IMPARATO, DBA I.AM.YOU. STUDIO, NEW YORK, NY. FILED 1-3-2011.



NO CLAIM IS MADE TO THE EXCLUSIVE RIGHT TO USE "STUDIO", APART FROM THE MARK AS SHOWN. THE MARK CONSISTS OF THE WORDING "I.AM.YOU STUDIO DETOX TO RETOX", STYLIZED.

CLASS 41—EDUCATION AND ENTERTAINMENT

FOR YOGA INSTRUCTION (U.S. CLS. 100, 101 AND 107).

CLASS 44—MEDICAL, BEAUTY AND AGRICULTURAL SERVICES

FOR COUNSELING SERVICES IN THE FIELDS OF HEALTH, NUTRITION AND LIFESTYLE WELLNESS; DIETARY AND NUTRITIONAL GUIDANCE; FOOD NUTRITION CONSULTATION; NUTRITION COUNSELING; NUTRITIONAL THERAPY SERVICES; PROVIDING A WEB SITE FEATURING INFORMATION ON HEALTH AND NUTRITION; PROVIDING A WEB SITE THAT FEATURES INFORMATION ON CHILDREN'S NUTRITION; PROVIDING A WEBSITE FEATURING INFORMATION ABOUT HEALTH, WELLNESS AND NUTRITION; PROVIDING AN ON-LINE COMPUTER DATABASE FEATURING INFORMATION REGARDING HEALTH AND NUTRITION; PROVIDING ASSISTANCE, FITNESS EVALUATION AND CONSULTATION TO CORPORATE CLIENTS TO HELP THEIR EMPLOYEES MAKE HEALTH, WELLNESS AND NUTRITIONAL CHANGES IN THEIR DAILY LIVING TO IMPROVE HEALTH; PROVIDING ASSISTANCE, FITNESS EVALUATION AND CONSULTATION TO INDIVIDUALS TO HELP THEM MAKE HEALTH, WELLNESS AND NUTRITIONAL CHANGES IN THEIR DAILY LIVING TO IMPROVE HEALTH; PROVIDING HEALTHY LIFESTYLE AND NUTRITION SERVICES, NAMELY, PERSONAL ASSESSMENTS, PERSONALIZED ROUTINES, MAINTENANCE SCHEDULES, AND COUNSELING; PROVIDING INFORMATION ABOUT DIETARY SUPPLEMENTS AND NUTRITION; PROVIDING INFORMATION, NEWS AND COMMENTARY IN THE FIELD OF NUTRITION, HEALTH AND WELLNESS (U.S. CLS. 100 AND 101).

BARNEY CHARLON, EXAMINING ATTORNEY

SN 85-209,199. ONMOBILE GLOBAL LIMITED, BANGALORE, INDIA, FILED 1-3-2011.



OWNER OF U.S. REG. NO. 2,777,362.
THE MARK CONSISTS OF THE TERM "ONMOBILE", WITH AN ARC APPEARING FROM THE BOTTOM-LEFT CORNER TO THE DOT OF THE "I".
SEC. 2(F).

CLASS 38—COMMUNICATION

FOR TELECOMMUNICATION SERVICES, NAMELY, PROVIDING ADVANCED CALLING FEATURES; ELECTRONIC DATA TRANSMISSION, NAMELY, DELIVERY OF MUSIC, SPORTS SCORES AND UPDATES, JOKES, AND INFORMATION IN THE FIELD OF ENTERTAINMENT VIA MOBILE TELEPHONES TO USERS VIA VOICE, TEXT MESSAGING AND WIRELESS DEVICES (U.S. CLS. 100, 101 AND 104).

FIRST USE 8-0-2001; IN COMMERCE 8-0-2001.

CLASS 41—EDUCATION AND ENTERTAINMENT

FOR ENTERTAINMENT SERVICES, NAMELY, MULTIMEDIA PROGRAMS FEATURING MUSIC, SPORTS, COMEDY, AND ENTERTAINMENT, PROVIDED VIA MOBILE TELEPHONE TO USERS VIA VOICE, TEXT MESSAGING AND WIRELESS DEVICES (U.S. CLS. 100, 101 AND 107).

FIRST USE 8-0-2001; IN COMMERCE 8-0-2001.

CLASS 42—SCIENTIFIC AND COMPUTER SERVICES

FOR APPLICATION SERVICE PROVIDER (ASP) FEATURING SOFTWARE FOR USE IN DELIVERING CONTENT TO PHONES AND MOBILE DEVICES; APPLICATION SERVICE PROVIDER (ASP) FEATURING SOFTWARE, NAMELY, ADDRESS BOOKS, E-MAIL MANAGERS, INTERNET BOOKMARK MANAGERS, ANTI-THEFT PROTECTION, AND BACKUP UTILITIES FOR USE ON PHONES AND MOBILE DEVICES; COMPUTER TECHNICAL SUPPORT SERVICES, NAMELY, TROUBLESHOOTING OF COMPUTER SOFTWARE PROBLEMS, HELP DESK SERVICES FOR IT INFRASTRUCTURE, AND MONITORING OF NETWORK SYSTEMS; SOFTWARE DEVELOPMENT AND DESIGN; RENTAL OF COMPUTER HARDWARE; RENTAL OF COMPUTER SOFTWARE (U.S. CLS. 100 AND 101).

FIRST USE 8-0-2001; IN COMMERCE 8-0-2001.
JANET LEE, EXAMINING ATTORNEY

SN 85-209,203. SANDRA K., INC., WOODBURY, NY. FILED 1-3-2011.

PETS EN VOGUE

THE MARK CONSISTS OF STANDARD CHARACTERS WITHOUT CLAIM TO ANY PARTICULAR FONT, STYLE, SIZE, OR COLOR.

NO CLAIM IS MADE TO THE EXCLUSIVE RIGHT TO USE "PETS", APART FROM THE MARK AS SHOWN.

CLASS 18—LEATHER GOODS

FOR PET CLOTHING (U.S. CLS. 1, 2, 3, 22 AND 41).

CLASS 21—HOUSEWARES AND GLASS

FOR PET FEEDING AND DRINKING BOWLS (U.S. CLS. 2, 13, 23, 29, 30, 33, 40 AND 50).

JANET LEE, EXAMINING ATTORNEY

SN 85-211,606. VALUEOPTIONS, INC., NORFOLK, VA. FILED 1-6-2011.

PROVIDER PULSE

THE MARK CONSISTS OF STANDARD CHARACTERS WITHOUT CLAIM TO ANY PARTICULAR FONT, STYLE, SIZE, OR COLOR.

NO CLAIM IS MADE TO THE EXCLUSIVE RIGHT TO USE "PROVIDER", APART FROM THE MARK AS SHOWN.

CLASS 35—ADVERTISING AND BUSINESS

FOR COLLECTION OF INFORMATION INTO COMPUTER DATABASES, NAMELY, CREDENTIALING AND OTHER BUSINESS INFORMATION FOR HEALTH CARE PROVIDERS (U.S. CLS. 100, 101 AND 102).

CLASS 38—COMMUNICATION

FOR TELECOMMUNICATION SERVICES, NAMELY, PROVIDING ELECTRONIC MESSAGE NOTIFICATION ALERTS TO HEALTH CARE PROVIDERS OF CREDENTIALING AND OTHER BUSINESS INFORMATION (U.S. CLS. 100, 101 AND 104).

CLASS 39—TRANSPORTATION AND STORAGE

FOR ELECTRONIC STORAGE OF CREDENTIALING AND OTHER BUSINESS INFORMATION FOR HEALTH CARE PROVIDERS (U.S. CLS. 100 AND 105).

CLASS 41—EDUCATION AND ENTERTAINMENT

FOR PROVIDING HEALTH CARE EDUCATION INFORMATION ADVISING HEALTH CARE PROVIDERS OF UPCOMING EDUCATIONAL AND TRAINING EVENTS AND TRAINING OPPORTUNITIES VIA E-MAIL NOTIFICATION ALERTS (U.S. CLS. 100, 101 AND 107).

CLASS 42—SCIENTIFIC AND COMPUTER SERVICES

FOR PROVIDING HEALTH CARE CREDENTIALING INFORMATION, NAMELY, ACCREDITATION INFORMATION VIA E-MAIL NOTIFICATION ALERTS (U.S. CLS. 100 AND 101).

DANIEL CAPSHAW, EXAMINING ATTORNEY

SN 85-214,072. DAUM, DEBRA, SENECA, SC. FILED 1-10-2011.

The Paul Revere Promise

THE MARK CONSISTS OF STANDARD CHARACTERS WITHOUT CLAIM TO ANY PARTICULAR FONT, STYLE, SIZE, OR COLOR.

THE NAME(S), PORTRAIT(S), AND/OR SIGNATURE(S) SHOWN IN THE MARK DOES NOT IDENTIFY A PARTICULAR LIVING INDIVIDUAL.

CLASS 25—CLOTHING

FOR CAPS; HATS; T-SHIRTS (U.S. CLS. 22 AND 39).

CLASS 35—ADVERTISING AND BUSINESS

FOR MOBILE RETAIL STORE SERVICES FEATURING BUTTONS, LANTERNS, PENS, MUGS, TOTE BAGS, POSTERS, SIGNS, CLOTHING; ON-LINE RETAIL STORE SERVICES FEATURING BUTTONS, LANTERNS, PENS, MUGS, TOTE BAGS, POSTERS, SIGNS; POLITICAL PARTY SERVICES, NAMELY, PROMOTING THE INTERESTS OF A POLITICAL ORGANIZATION (U.S. CLS. 100, 101 AND 102).

MAUREEN DALL, EXAMINING ATTORNEY

SN 85-215,449. HUMBLE EARTH PRODUCTIONS, INC., BEN LOMOND, CA. FILED 1-11-2011.

SN 85-221,382. TOM.COM ENTERPRISES LIMITED, TORTOLA, BR.VIRGIN ISLANDS, FILED 1-19-2011.

HUMBLE EARTH

THE MARK CONSISTS OF STANDARD CHARACTERS WITHOUT CLAIM TO ANY PARTICULAR FONT, STYLE, SIZE, OR COLOR.

CLASS 9—ELECTRICAL AND SCIENTIFIC APPARATUS

FOR ELECTRONIC PUBLICATIONS, NAMELY, CHILDREN'S EDUCATIONAL PICTURE BOOKS RECORDED ON COMPUTER MEDIA (U.S. CLS. 21, 23, 26, 36 AND 38).

CLASS 11—ENVIRONMENTAL CONTROL APPARATUS

FOR LIGHTING FIXTURES, NAMELY, LIGHT EMITTING DIODE DECORATION SPECIALLY DESIGNED TO MIMIC THE EFFECT OF FIREFLIES; LIGHTING FIXTURES, NAMELY, ELECTRONIC LIGHT EMITTING DEVICES SPECIALLY DESIGNED LIGHT EMITTING DEVICES THAT MIMIC THE EFFECT OF FIREFLIES (U.S. CLS. 13, 21, 23, 31 AND 34).

CLASS 41—EDUCATION AND ENTERTAINMENT

FOR ELECTRONIC DESKTOP PUBLISHING OF BOOKS FOR OTHERS (U.S. CLS. 100, 101 AND 107).
ALYSSA STEEL, EXAMINING ATTORNEY

SN 85-217,910. OCI MELAMINE B.V., 6167 AC GELEEN, NETHERLANDS, FILED 1-14-2011.

PROLIGNEA

THE MARK CONSISTS OF STANDARD CHARACTERS WITHOUT CLAIM TO ANY PARTICULAR FONT, STYLE, SIZE, OR COLOR.

PRIORITY CLAIMED UNDER SEC. 44(D) ON BENELUX APPLICATION NO. 1206653, FILED 7-16-2010, REG. NO. 0884723, DATED 7-19-2010, EXPIRES 7-16-2020.

CLASS 1—CHEMICALS

FOR CHEMICAL PRODUCTS FOR INDUSTRIAL PURPOSES, ARTIFICIAL RESINS AS RAW MATERIALS, ADHESIVES FOR INDUSTRIAL PURPOSES, MELAMINE FOR INDUSTRIAL USE (U.S. CLS. 1, 5, 6, 10, 26 AND 46).

CLASS 45—PERSONAL AND LEGAL SERVICES

FOR LICENSING OF INTELLECTUAL PROPERTY (U.S. CLS. 100 AND 101).
IRA J. GOODSАID, EXAMINING ATTORNEY



tom

OWNER OF HONG KONG REG. NO. 2002B11347, DATED 12-15-1999, EXPIRES 12-15-2020.

OWNER OF HONG KONG REG. NO. 2002B11346, DATED 12-15-1999, EXPIRES 12-15-2020.

OWNER OF HONG KONG REG. NO. 2002B11345, DATED 12-15-1999, EXPIRES 12-15-2020.

OWNER OF HONG KONG REG. NO. 2002B11344, DATED 12-15-1999, EXPIRES 12-15-2020.

OWNER OF HONG KONG REG. NO. 2002B09503, DATED 12-15-1999, EXPIRES 12-15-2020.

OWNER OF HONG KONG REG. NO. 2002B11343, DATED 12-15-1999, EXPIRES 12-15-2020.

OWNER OF HONG KONG REG. NO. 2002B11342, DATED 12-15-1999, EXPIRES 12-15-2020.

OWNER OF U.S. REG. NOS. 2,900,971, 3,047,193 AND OTHERS.

THE MARK CONSISTS OF THE WORD "TOM" IN STYLIZED LETTERS WITH A FLOWER DESIGN WITHIN A CIRCLE.

CLASS 9—ELECTRICAL AND SCIENTIFIC APPARATUS

FOR ELECTRIC, ELECTRONIC, FACSIMILE, TELETYPEWRITER, TELEPHONE, TELEGRAM, RADIO PAGING, TELECOMMUNICATIONS, DATA COMMUNICATIONS AND DATA ACQUISITION INSTALLATIONS, APPARATUS AND INSTRUMENTS, NAMELY, INTERNET PROTOCOL VOICE TELEPHONES, MOBILE TELEPHONES, ELECTRICAL AND ELECTRONIC SIGNBOARDS (U.S. CLS. 21, 23, 26, 36 AND 38).

CLASS 35—ADVERTISING AND BUSINESS

FOR ADVERTISING AGENCIES; PROMOTING THE GOODS AND SERVICES OF OTHERS THROUGH DISTRIBUTION OF ADVERTISING VIA A GLOBAL COMPUTER NETWORK AND CONSUMER PRODUCT INFORMATION RELATED THERETO; PREPARING AND PLACING ADVERTISEMENTS ON WEB SITES FOR OTHERS; PROVIDING AN ONLINE COMPUTER DATABASE IN THE FIELD OF ONLINE ADVERTISEMENT DISTRIBUTION, DIRECT MARKETING AND TARGETED MARKETING; OPERATING AN ONLINE MARKETPLACE FOR BUYERS AND SELLERS OF PRODUCTS AND SERVICES (U.S. CLS. 100, 101 AND 102).

CLASS 36—INSURANCE AND FINANCIAL

FOR PROVIDING AN ONLINE COMPUTER DATABASE FEATURING FINANCIAL AND INSURANCE INFORMATION (U.S. CLS. 100, 101 AND 102).

CLASS 37—CONSTRUCTION AND REPAIR

FOR ONLINE INFORMATION SERVICES RELATING TO REPAIR AND INSTALLATION OF TELECOMMUNICATIONS AND COMMUNICATIONS APPARATUS, COMPUTERS AND COMPUTER PERIPHERALS, ELECTRONIC EQUIPMENT, ANTENNAE, HARDWARE USED TO SUPPORT THIRD-PARTY WEB HOSTING, AND IT PRODUCTS INCLUDING CELL PHONES AND HANDHELD PRODUCTS; REPAIR AND INSTALLATION OF TELECOMMUNICATIONS AND COMMUNICATIONS APPARATUS, COMPUTERS AND COMPUTER PERIPHERALS, ELECTRONIC EQUIPMENT, ANTENNAS, HARDWARE USED TO SUPPORT THIRD-PARTY WEB HOSTING, IT PRODUCTS INCLUDING CELL PHONES AND HANDHELD PRODUCTS (U.S. CLS. 100, 103 AND 106).

CLASS 38—COMMUNICATION

FOR TELECOMMUNICATIONS SERVICES, NAMELY, FACSIMILE, TELETYPEWRITER, TELEPHONE, TELEGRAM, MESSAGE COLLECTION AND TRANSMISSION SERVICES VIA ELECTRONIC MEANS, INTERNET PROTOCOL VOICE PHONE, ELECTRONIC MESSAGING, ELECTRICAL AND ELECTRONIC SIGNBOARDS, UNIFY MESSAGING AND VOICE BROWSING; ELECTRONIC TRANSMISSION OF DATA AND INFORMATION VIA COMPUTER TERMINALS, COMPUTER NETWORKS, CABLE AND RADIO; RENTAL OF MOBILE COMMUNICATIONS DEVICES, NAMELY, TELEPHONES AND TELECOMMUNICATIONS EQUIPMENT (U.S. CLS. 100, 101 AND 104).

CLASS 41—EDUCATION AND ENTERTAINMENT

FOR PROVIDING ONLINE INFORMATION VIA A GLOBAL COMPUTER NETWORK ABOUT EDUCATION; PROVIDING ONLINE INFORMATION VIA A GLOBAL COMPUTER NETWORK IN THE FIELDS OF ENTERTAINMENT, SPORTS AND LEISURE; ENTERTAINMENT SERVICES, NAMELY, ELECTRONIC GAMES PROVIDED VIA A GLOBAL COMPUTER NETWORK; RENTAL OF AUDIO/VISUAL EQUIPMENT, NAMELY, CAMERAS, CAMCORDERS, DVD PLAYERS, CD PLAYERS, TV RECEIVERS, TV PROJECTORS, VIDEO CASSETTE RECORDERS, VIDEO CASSETTE PLAYERS, AND VIDEO MONITORS (U.S. CLS. 100, 101 AND 107).

CLASS 42—SCIENTIFIC AND COMPUTER SERVICES

FOR TESTING SERVICES, NAMELY, TESTING OF COMPUTING, TELECOMMUNICATIONS, ELECTRICAL AND ELECTRONIC APPARATUS AND INSTRUMENTS FOR WORKING EFFICIENCY; MOBILE INTERNET PLATFORM DEVELOPMENT; BROADBAND INTERNET PLATFORM DEVELOPMENT (U.S. CLS. 100 AND 101).
ERIN FALK, EXAMINING ATTORNEY

SN 85-221,783, TRAKLOK CORPORATION, KNOXVILLE, TN, FILED 1-20-2011.

GEOCASE

THE MARK CONSISTS OF STANDARD CHARACTERS WITHOUT CLAIM TO ANY PARTICULAR FONT, STYLE, SIZE, OR COLOR.

CLASS 6—METAL GOODS

FOR METAL MAN-PORTABLE SHIPPING CONTAINERS, EACH FEATURING AN ELECTRONIC LOCK AND AN ELECTROMAGNETIC TRANSMITTER FOR TRACKING SUCH CONTAINERS (U.S. CLS. 2, 12, 13, 14, 23, 25 AND 50).

CLASS 11—ENVIRONMENTAL CONTROL APPARATUS

FOR REFRIGERATED MAN-PORTABLE SHIPPING CONTAINERS, EACH FEATURING AN ELECTRONIC LOCK AND AN ELECTROMAGNETIC TRANSMITTER FOR TRACKING SUCH CONTAINERS (U.S. CLS. 13, 21, 23, 31 AND 34).

CLASS 20—FURNITURE AND ARTICLES NOT OTHERWISE CLASSIFIED

FOR NON-METAL MAN-PORTABLE SHIPPING CONTAINERS, EACH FEATURING AN ELECTRONIC LOCK AND AN ELECTROMAGNETIC TRANSMITTER FOR TRACKING SUCH CONTAINERS (U.S. CLS. 2, 13, 22, 25, 32 AND 50).

ALICE BENMAMAN, EXAMINING ATTORNEY

SN 85-223,502, NOODLE TIME, INC., MIAMI, FL. FILED 1-21-2011.



OWNER OF U.S. REG. NOS. 937,781, 1,426,792 AND 2,030,592.

THE MARK CONSISTS OF A BOLD RECTANGULAR OUTLINE WITH ROUNDED EDGES ENCOMPASSING THE DESIGN OF A FLOWER WITH STEM AND LEAVES. WITHIN THE PETALS OF THE FLOWER APPEAR NINE DOTS.

CLASS 8—HAND TOOLS

FOR CHEF KNIVES; FLATWARE AND CUTLERY NAMELY, FORKS, KNIVES AND SPOONS (U.S. CLS. 23, 28 AND 44).

CLASS 21—HOUSEWARES AND GLASS

FOR SERVING DISHES, SERVING BOWLS, SERVING FORKS, SERVING SPOONS, SERVING TONGS, SERVING TRAYS, SERVING LADLES, AND SERVING PLATTERS NOT OF PRECIOUS METAL; BOWLS; JAPANESE RICE BOWLS NOT OF PRECIOUS METAL; CHOPSTICKS, CHOPSTICK RESTS, AND CHOPSTICK CASES; SALT AND PEPPER SHAKERS; TEA SETS; SAKE CUPS AND SERVING BOTTLES NOT OF PRECIOUS METAL (U.S. CLS. 2, 13, 23, 29, 30, 33, 40 AND 50).

CLASS 29—MEATS AND PROCESSED FOODS

FOR FROZEN APPETIZERS AND MEALS CONSISTING PRIMARILY OF MEAT, SEAFOOD, POULTRY, OR VEGETABLES, WITH AND WITHOUT SEASONINGS AND SAUCES; PRE-PACKAGED APPETIZERS AND MEALS CONSISTING PRIMARILY OF MEAT, SEAFOOD, POULTRY, OR VEGETABLES, WITH AND WITHOUT SEASONINGS AND SAUCES; PREPARATIONS FOR MAKING SOUPS; MARINATED OR SEASONED MEAT, SEAFOOD, POULTRY, OR VEGETABLES; FROZEN MEAT, SEAFOOD, POULTRY, OR VEGETABLES (U.S. CL. 46).

CLASS 30—STAPLE FOODS

FOR FROZEN AND PRE-PACKAGED APPETIZERS AND MEALS CONSISTING PRIMARILY OF PASTA, NOODLES, OR RICE WITH AND WITHOUT SEASONINGS AND SAUCES; PRE-PACKAGED APPETIZERS AND MEALS CONSISTING PRIMARILY OF PASTA, NOODLES, OR RICE WITH AND WITHOUT SEASONINGS AND SAUCES; SALAD DRESSINGS; COOKING SAUCES; SOY SAUCE; TERIYAKI SAUCE; NOODLES; NOODLES OR RICE WITH SAUCE AND SEASONING TOPPINGS COMBINED IN UNITARY PACKAGES; SEASONING MIXES; FOOD SEASONINGS; RICE; ASIAN NOODLES (U.S. CL. 46).

SUZANNE BLANE, EXAMINING ATTORNEY

CLASS 41—EDUCATION AND ENTERTAINMENT

FOR PROVIDING NEWS AND INFORMATION IN THE FIELD OF THEATRICAL EVENTS, ENTERTAINMENT, AND OTHER THEATER RELATED SUBJECTS, NAMELY, THEATER PRODUCTIONS AND LIVE CONCERT PRODUCTIONS VIA GLOBAL AND LOCAL COMMUNICATIONS NETWORKS; ENTERTAINMENT SERVICES, NAMELY, PROVIDING A WEBSITE FEATURING NON-DOWNLOADABLE THEATRICAL PERFORMANCES BY INDIVIDUALS OR GROUPS; PROVIDING A WEBSITE FEATURING NON-DOWNLOADABLE AUDIO AND VIDEO PRERECORDED MUSICAL PERFORMANCES AND THEATER PRODUCTIONS BY AN INDIVIDUAL OR A GROUP; ENTERTAINMENT, NAMELY, PERSONAL APPEARANCES BY A CELEBRITY OR CELEBRITIES IN THE FIELD OF THEATER; PROVIDING THEATER LISTINGS; ENTERTAINMENT SERVICES, NAMELY, PROVIDING A WEBSITE FEATURING NON-DOWNLOADABLE AUDIO, VIDEO AND MULTIMEDIA THEATER PERFORMANCES; ARRANGING FOR TICKET RESERVATIONS FOR SHOWS AND OTHER ENTERTAINMENT EVENTS; ELECTRONIC PUBLISHING SERVICES, NAMELY, PUBLICATION OF TEXT, GRAPHIC, AUDIO-VIDEO AND MULTIMEDIA WORKS OF OTHERS ONLINE IN THE FIELD OF THEATER PERFORMANCES AND PRODUCTIONS; ARRANGING AND CONDUCTING THEATER RELATED COMPETITIONS AND SWEEPSTAKES; TICKET RESERVATIONS AND BOOKINGS SERVICES FOR THEATER PERFORMANCES AND EVENTS; THEATRICAL TICKET AGENCIES; PROVIDING ON-LINE MAGAZINES AND NEWSLETTERS IN THE FIELD OF THEATER PERFORMANCES AND PRODUCTIONS (U.S. CLS. 100, 101 AND 107).

EVELYN BRADLEY, EXAMINING ATTORNEY

SN 85-225,468. PLAYBILL INCORPORATED, WOODSIDE, NY. FILED 1-25-2011.

SN 85-225,987. HUNT COMPANIES, INC., EL PASO, TX. FILED 1-25-2011.

PLAYBILL SMARTSTORE

THE MARK CONSISTS OF STANDARD CHARACTERS WITHOUT CLAIM TO ANY PARTICULAR FONT, STYLE, SIZE, OR COLOR.

OWNER OF U.S. REG. NOS. 1,109,328, 3,776,531 AND OTHERS.

CLASS 35—ADVERTISING AND BUSINESS

FOR PROVIDING AN ON-LINE DIRECTORY INFORMATION SERVICE FEATURING SEARCHABLE INFORMATION AND LISTINGS FEATURING THEATER RELATED SUBJECTS; PROVIDING ON-LINE RETAIL STORE SERVICES FEATURING THEATER RELATED BOOKS, ARTWORK, APPAREL, POSTERS, RECORDINGS AND OTHER THEATER RELATED MERCHANDISE; BUYING CLUB SERVICES (U.S. CLS. 100, 101 AND 102).

CLASS 38—COMMUNICATION

FOR PROVIDING ON-LINE CHAT ROOMS AND ELECTRONIC BULLETIN BOARDS FOR TRANSMISSION OF MESSAGES AMONG COMPUTER USERS CONCERNING THEATER RELATED TOPICS; STREAMING OF ENTERTAINMENT IN THE NATURE OF AUDIO AND VISUAL THEATRICAL PERFORMANCES OF INDIVIDUALS OR GROUPS VIA A GLOBAL COMPUTER NETWORK (U.S. CLS. 100, 101 AND 104).

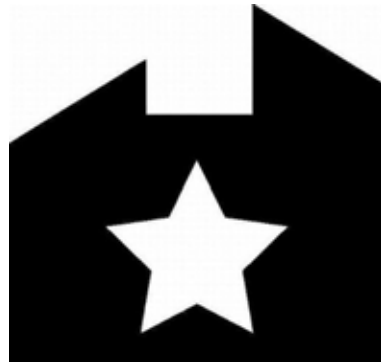

THE MARK CONSISTS OF THE OUTLINE OF A BLACK HOUSE ON A WHITE BACKGROUND WITH A WHITE STAR IN THE MIDDLE OF THE HOUSE.

CLASS 36—INSURANCE AND FINANCIAL

FOR SERVICES PROVIDED IN CONNECTION WITH THE PROVISION OF MILITARY HOUSING ON OR ASSOCIATED WITH U.S. MILITARY BASES AND POSTS, NAMELY, REAL ESTATE MANAGEMENT AND REAL ESTATE OPERATION SERVICES, NAMELY, REAL ESTATE PROPERTY MANAGEMENT SERVICES (U.S. CLS. 100, 101 AND 102).

FIRST USE 12-18-2008; IN COMMERCE 12-18-2008.

CLASS 37—CONSTRUCTION AND REPAIR

FOR SERVICES PROVIDED IN CONNECTION WITH THE PROVISION OF MILITARY HOUSING ON OR ASSOCIATED WITH U.S. MILITARY BASES AND POSTS, NAMELY, REAL ESTATE DEVELOPMENT AND CONSTRUCTION OF HOUSES AND BUILDINGS (U.S. CLS. 100, 103 AND 106).

FIRST USE 12-18-2008; IN COMMERCE 12-18-2008.
MATTHEW EINSTEIN, EXAMINING ATTORNEY

CLASS 16—PAPER GOODS AND PRINTED MATTER

FOR PRINTED EDUCATIONAL INSTRUCTION AND TRAINING MATERIALS, NAMELY, PRINTED PRESENTATION IN THE NATURE OF EDUCATIONAL BOOKS AND PAMPHLETS, PRINTS OF POWERPOINT SLIDES, AND TRAINING MATERIALS WITH INFORMATION ON PRESERVING, SUSTAINING, AND RESTORING ENVIRONMENTAL RESOURCES (U.S. CLS. 2, 5, 22, 23, 29, 37, 38 AND 50).

CLASS 41—EDUCATION AND ENTERTAINMENT

FOR EDUCATIONAL SERVICES, NAMELY, TRAINING, TUTORING, SEMINARS, NON-DOWNLOADABLE WEBINARS, TELECONFERENCES, CLASSES AND EDUCATIONAL TESTING ALL IN THE FIELD OF PRESERVING, SUSTAINING, AND RESTORING ENVIRONMENTAL RESOURCES (U.S. CLS. 100, 101 AND 107).

JESSICA A. POWERS, EXAMINING ATTORNEY

SN 85-226,444. HOME MARKET FOODS, INC., NORWOOD, MA. FILED 1-26-2011.

BOLDER

THE MARK CONSISTS OF STANDARD CHARACTERS WITHOUT CLAIM TO ANY PARTICULAR FONT, STYLE, SIZE, OR COLOR.

CLASS 29—MEATS AND PROCESSED FOODS

FOR FROZEN MEALS AND SNACKS CONSISTING PRIMARILY OF MEAT (U.S. CL. 46).

CLASS 30—STAPLE FOODS

FOR SANDWICHES (U.S. CL. 46).
CHRISTINE COOPER, EXAMINING ATTORNEY

SN 85-226,757. YINGKOU BRIGHT TECHNOLOGY CO., LTD., YINGKOU CITY, CHINA, FILED 1-26-2011.



SN 85-226,687. TRAINING IN ENVIRONMENTAL RESOURCES, FIRTH, NE. FILED 1-26-2011.

TIER

THE MARK CONSISTS OF STANDARD CHARACTERS WITHOUT CLAIM TO ANY PARTICULAR FONT, STYLE, SIZE, OR COLOR.

CLASS 9—ELECTRICAL AND SCIENTIFIC APPARATUS

FOR ELECTRONIC EDUCATIONAL INSTRUCTION AND TRAINING MATERIALS, NAMELY, ELECTRONIC PRESENTATIONS, WEBINARS AND TELECONFERENCING PROVIDED ON CDS, DVDS, VIDEO STORAGE DEVICES, NAMELY, PRE-RECORDED FLASH DRIVES, PRE-RECORDED USB-CONNECTED DRIVES, MP3S, AND WEBSITES AND EMBEDDED TRAINING WITHIN WEBSITES STORED ON COMPUTER AND HARD DRIVES, WITH INFORMATION ON PRESERVING, SUSTAINING, AND RESTORING ENVIRONMENTAL RESOURCES (U.S. CLS. 21, 23, 26, 36 AND 38).

THE MARK CONSISTS OF THE TERM "BRIGHT" IN A STYLIZED FORMAT WITH AN IMAGE OF A WHEEL RINGED WITH FIRE DOTTING THE "I" AND THE IMAGE OF A FLYING BIRD OVER A STYLIZED LETTER "G" TO THE LEFT WITH A CIRCLE THAT HAS AN EAGLE INSIDE ABOVE THE LETTER "B".

CLASS 7—MACHINERY

FOR POWERED TIRE CHANGER MACHINES FOR LAND VEHICLES; ELEVATORS (U.S. CLS. 13, 19, 21, 23, 31, 34 AND 35).

FIRST USE 1-20-2009; IN COMMERCE 1-20-2009.

CLASS 9—ELECTRICAL AND SCIENTIFIC APPARATUS

FOR TIRE BALANCING MACHINES FOR LAND VEHICLES (U.S. CLS. 21, 23, 26, 36 AND 38).

FIRST USE 1-20-2009; IN COMMERCE 1-20-2009.
RAMONA ORTIGA, EXAMINING ATTORNEY

SN 85-229,005. METALSA, S.A. DE C.V., APODACA, NUEVO LEON, MEXICO, FILED 1-28-2011.

Quality as a way of life

THE MARK CONSISTS OF STANDARD CHARACTERS WITHOUT CLAIM TO ANY PARTICULAR FONT, STYLE, SIZE, OR COLOR.

CLASS 12—VEHICLES

FOR CHASSIS FOR MOTOR VEHICLES; FRAME ASSEMBLIES FOR MOTOR VEHICLES; CRADLES FOR MOTOR VEHICLES; LAND VEHICLE SUSPENSION PARTS, NAMELY, TORSION/SWAY BARS, AXLES AND CONTROL ARMS; MOTOR VEHICLE BODY STRUCTURES; SIDE RAILS AND CROSS MEMBERS FOR COMMERCIAL VEHICLES; STEEL FUEL TANKS FOR MOTOR VEHICLES; STORAGE BOXES FOR MOTOR VEHICLES (U.S. CLS. 19, 21, 23, 31, 35 AND 44).

FIRST USE 1-27-2011; IN COMMERCE 1-27-2011.

CLASS 40—MATERIAL TREATMENT

FOR MANUFACTURING SERVICES FOR OTHERS IN THE FIELD OF VEHICLE COMPONENTS; BLANKING, HYDROFORMING CELLS; ROLL FORMING; LASER, PLASMA AND MECHANICAL CUTTING; ROBOT PIERCING; WELDING; PROTOTYPE FABRICATION OF NEW PRODUCTS FOR OTHERS; PROVIDING TECHNICAL INFORMATION IN THE FIELD OF VEHICLE STRUCTURES MANUFACTURING (U.S. CLS. 100, 103 AND 106).

FIRST USE 0-0-2000; IN COMMERCE 0-0-2000.

CLASS 42—SCIENTIFIC AND COMPUTER SERVICES

FOR TESTING, DESIGN, AND ENGINEERING SERVICES IN THE FIELD OF STRUCTURAL VEHICLE COMPONENTS (U.S. CLS. 100 AND 101).

FIRST USE 0-0-2000; IN COMMERCE 0-0-2000.
KEVON CHISOLM, EXAMINING ATTORNEY

SN 85-229,754. ANGEL BUSTER D.B.A. INDRA'S NET, 2042 GP ZANDVOORT, NETHERLANDS, FILED 1-31-2011.

HAAPPi

THE MARK CONSISTS OF STANDARD CHARACTERS WITHOUT CLAIM TO ANY PARTICULAR FONT, STYLE, SIZE, OR COLOR.

CLASS 9—ELECTRICAL AND SCIENTIFIC APPARATUS

FOR COMPUTER SOFTWARE FOR USE IN CONNECTION WITH A PERSONAL DEVELOPMENT PLAN AND A PERSONAL COACHING PACKAGE; PRE-RECORDED COMPACT DISCS AND DVD'S FEATURING CONTENT IN THE FIELD OF YOGA AND NUTRITION (U.S. CLS. 21, 23, 26, 36 AND 38).

CLASS 16—PAPER GOODS AND PRINTED MATTER

FOR PRINTED INSTRUCTIONAL MATERIAL, BOOKS, PERIODICALS, MANUALS, MAGAZINES AND HANDBOOKS IN THE FIELD OF YOGA, NUTRITION, PERSONAL DEVELOPMENT AND PERSONAL COACHING; CALENDARS (U.S. CLS. 2, 5, 22, 23, 29, 37, 38 AND 50).

CLASS 41—EDUCATION AND ENTERTAINMENT

FOR EDUCATIONAL SERVICES, NAMELY, PROVIDING CLASSES, WORKSHOPS AND SEMINARS IN THE FIELD OF YOGA, NUTRITION, PERSONAL DEVELOPMENT AND PERSONAL COACHING; BUSINESS EDUCATION AND TRAINING SERVICES, NAMELY, DEVELOPING AND FACILITATING CUSTOMIZED LEADERSHIP AND EXECUTIVE DEVELOPMENT PROGRAMS, PROVIDING EXECUTIVE AND EMPLOYEE COACHING SERVICES; PUBLICATION OF BOOKS (U.S. CLS. 100, 101 AND 107).

CLASS 45—PERSONAL AND LEGAL SERVICES

FOR PERSONAL COACHING SERVICES IN THE FIELD OF PERSONAL DEVELOPMENT, NAMELY, SELF-IMPROVEMENT, SELF-FULFILLMENT AND HOLISTIC HEALTH (U.S. CLS. 100 AND 101).

NAPOLEON SHARMA, EXAMINING ATTORNEY

SN 85-230,133. THINK SIMPLE S.P.A., PORDENONE, ITALY, FILED 1-31-2011.

THINK  SIM

THE MARK CONSISTS OF AN OVAL DESIGN BETWEEN THE WORDS "THINK" AND "SIMPLE".

CLASS 9—ELECTRICAL AND SCIENTIFIC APPARATUS

FOR SCIENTIFIC, NAUTICAL, SURVEYING, PHOTOGRAPHIC, CINEMATOGRAPHIC, OPTICAL, WEIGHING, MEASURING, SIGNALING, CHECKING, LIFE-SAVING AND TEACHING APPARATUS AND INSTRUMENTS, NAMELY, REMOTE CONTROLS FOR BUILDING LIGHTING, FOR HVAC EQUIPMENT AND APPLICATIONS, FOR POWER OPERATED WINDOW CURTAINS AND FOR AUDIO AND VIDEO EQUIPMENT; APPARATUS AND INSTRUMENTS FOR CONDUCTING, SWITCHING, TRANSFORMING, ACCUMULATING, REGULATING OR CONTROLLING ELECTRICITY, NAMELY, WIRELESS TRANSMITTERS AND RECEIVERS, NETWORK ROUTERS, HOME AND OFFICE AUTOMATION SYSTEMS COMPRISING WIRELESS AND WIRED CONTROLLERS, CONTROLLED DEVICES, AND SOFTWARE FOR LIGHTING, HVAC, SECURITY AND SAFETY APPLICATIONS; APPARATUS FOR RECORDING, TRANSMISSION OR REPRODUCTION OF SOUND OR IMAGES; MAGNETIC DATA CARRIERS, RECORDING DISCS; AUTOMATIC VENDING MACHINES AND MECHANISMS FOR COIN-OPERATED APPARATUS; CASH REGISTERS, CALCULATING MACHINES, DATA PROCESSING EQUIPMENT AND COMPUTERS; FIRE-EXTINGUISHING APPARATUS (U.S. CLS. 21, 23, 26, 36 AND 38).

CLASS 11—ENVIRONMENTAL CONTROL APPARATUS

FOR APPARATUS FOR LIGHTING, HEATING, STEAM GENERATING, COOKING, REFRIGERATING, DRYING, VENTILATING, WATER SUPPLY AND SANITARY PURPOSES, NAMELY, HVAC UNITS, LIGHTING FIXTURES, AND AIR-CONDITIONING, AIR COOLING AND VENTILATION APPARATUS AND INSTRUMENTS (U.S. CLS. 13, 21, 23, 31 AND 34).

MEGHAN REINHART, EXAMINING ATTORNEY

SN 85-230,461. STEWBERG, INC., DBA THE NOVA CAFE, BOZEMAN, MT. FILED 1-31-2011.

The Nova Cafe

THE MARK CONSISTS OF STANDARD CHARACTERS WITHOUT CLAIM TO ANY PARTICULAR FONT, STYLE, SIZE, OR COLOR.

NO CLAIM IS MADE TO THE EXCLUSIVE RIGHT TO USE "CAFE" AS TO CLASS 043, APART FROM THE MARK AS SHOWN.

CLASS 21—HOUSEWARES AND GLASS

FOR COFFEE CUPS, TEA CUPS AND MUGS (U.S. CLS. 2, 13, 23, 29, 30, 33, 40 AND 50).

FIRST USE 10-15-2005; IN COMMERCE 10-15-2005.

CLASS 25—CLOTHING

FOR T-SHIRT (U.S. CLS. 22 AND 39).

FIRST USE 10-15-2005; IN COMMERCE 10-15-2005.

CLASS 43—HOTEL AND RESTAURANT SERVICES

FOR RESTAURANT (U.S. CLS. 100 AND 101).
FIRST USE 10-15-2005; IN COMMERCE 10-15-2005.
DEBRA LEE, EXAMINING ATTORNEY

SN 85-230,476. MARK-STYLER CO., LTD., TOKYO, JAPAN, FILED 1-31-2011.

jouetie®

THE MARK CONSISTS OF THE STYLIZED WORD "JOUETIE", FOLLOWED BY THE LOWER-CASE LETTER "A" WITHIN A CIRCLE.

THE WORDING "JOUETIE" HAS NO MEANING IN A FOREIGN LANGUAGE.

CLASS 3—COSMETICS AND CLEANING PREPARATIONS

FOR COSMETIC SOAPS; HAIR SHAMPOOS AND CONDITIONERS; DETERGENTS FOR HOUSEHOLD USE; DENTIFRICE; COSMETICS; HAIR CARE PREPARATIONS; PERFUMERY AND INCENSE (U.S. CLS. 1, 4, 6, 50, 51 AND 52).

CLASS 9—ELECTRICAL AND SCIENTIFIC APPARATUS

FOR SUNGLASSES; EYEGLASSES; EYEGLASS CHAINS AND CORDS; CASES FOR EYEGLASSES AND SUNGLASSES; EYEGLASS FRAMES; MOBILE PHONE STRAPS (U.S. CLS. 21, 23, 26, 36 AND 38).

CLASS 14—JEWELRY

FOR KEYRINGS OF PRECIOUS METALS; PERSONAL ORNAMENTS OF PRECIOUS METAL; CLOCKS AND WATCHES; EARRINGS, TIE CLIPS, TIE PINS, NECKLACES, BRACELETS, PENDANTS, JEWELLERY, BROOCHES, MEDALS, RINGS, MEDALLIONS, BANGLES, CUFFLINKS OF PRECIOUS METAL (U.S. CLS. 2, 27, 28 AND 50).

CLASS 18—LEATHER GOODS

FOR HANDBAG FRAMES; PURSE FRAMES; SHOULDER BAGS; HANDBAGS; SUITCASES; CARRY-ON BAGS; TRAVELLING TRUNKS; BOSTON BAGS; BACKPACKS; CHARM BAGS; BUSINESS CARD CASES; CREDIT CARD CASES; LEATHER AND TEXTILE SHOPPING BAGS; KEY CASES; PURSES AND WALLETS; VANITY CASES SOLD EMPTY; UMBRELLAS AND THEIR PADS; PET CLOTHING; COLLARS FOR PETS (U.S. CLS. 1, 2, 3, 22 AND 41).

CLASS 25—CLOTHING

FOR CLOTHING, NAMELY, JACKETS; BLOUSONS; SUITS; SKIRTS; ONE-PIECE DRESS FOR WOMEN; TROUSERS; PANTS; SHORTS; JEANS; COATS; SWEATERS; CARDIGANS; VESTS; PARKAS; PULLOVERS; SHIRTS; SPORT SHIRTS; BLOUSES; T-SHIRTS; CAMISOLES; TANK TOPS; NIGHTWEAR; UNDERWEAR; SWIMWEAR; SWIM CAPS; APRONS; SOCKS AND STOCKINGS; SHAWLS AND STOLEES; SCARVES; GLOVES AND MITTENS; NECKTIES; BANDANAS; MUFFLERS; EAR MUFFS; NIGHTCAPS; HEADWEAR; GARTERS; SOCK SUSPENDERS; SUSPENDERS; WAISTBANDS; BELTS FOR CLOTHING; FOOTWEAR; SPORTS PANTS; SPORTS JERSEYS; SPORTS JACKETS; SPORTS OVER UNIFORMS (U.S. CLS. 22 AND 39).

CLASS 26—FANCY GOODS

FOR HAIR BANDS; HAIR SLIDES; HAIR GRIPS; HAIR CLIPS; HAIR NETS; HAIR RIBBONS; HAIR SCRUNCHIES; HAIR ELASTICS; HAIR CHOPSTICKS; WIGS; HAIR EXTENSIONS; HAIR PINS (U.S. CLS. 37, 39, 40, 42 AND 50).

CLASS 35—ADVERTISING AND BUSINESS

FOR RETAIL AND WHOLESALE STORE SERVICES AND ON-LINE RETAIL AND WHOLESALE STORE SERVICES FEATURING COSMETICS, PERFUMERY, FRAGRANCES AND INCENSES, TOILETRIES, DENTIFRICES, SOAPS AND DETERGENTS; RETAIL AND WHOLESALE STORE SERVICES AND ON-LINE RETAIL AND WHOLESALE STORE SERVICES FEATURING CELLULAR PHONE STRAPS, SUNGLASSES, EYEGLASSES AND THEIR PARTS AND ACCESSORIES; RETAIL AND WHOLESALE STORE SERVICES AND ON-LINE RETAIL AND WHOLESALE STORE SERVICES FEATURING CLOCKS AND WATCHES, PERSONAL ORNAMENTS OF PRECIOUS METAL, KEYRINGS, JEWELRY CASES, TABLEWARE OF PRECIOUS METAL AND POWDER COMPACTS OF PRECIOUS METAL; RETAIL AND WHOLESALE STORE SERVICES AND ON-LINE RETAIL AND WHOLESALE STORE SERVICES FEATURING BAGS, POUCHES, HANDBAG FRAMES, PURSE FRAMES, UNFITTED VANITY CASES, PURSES, WALLETS AND UMBRELLAS; RETAIL AND WHOLESALE STORE SERVICES AND ON-LINE RETAIL AND WHOLESALE STORE SERVICES FEATURING CLOTHING, FOOTWEAR AND HEADWEAR; RETAIL AND

WHOLESALE STORE SERVICES AND ON-LINE RETAIL AND WHOLESALE STORE SERVICES FEATURING HAIR ACCESSORIES, WIGS AND HAIR PINS; RETAIL AND WHOLESALE STORE SERVICES AND ON-LINE RETAIL AND WHOLESALE STORE SERVICES FEATURING LIVINGWARE, NAMELY, DINNERWARE, COOKWARE, BEVERAGWARE; CONSULTATION AND ADVISING SERVICES OF BUSINESS MANAGEMENT RELATING TO THE FOREGOING RETAIL OR WHOLESALE SERVICES; PROVIDING INFORMATION RELATING TO THE FOREGOING RETAIL OR WHOLESALE SERVICES (U.S. CLS. 100, 101 AND 102).
COURTNEY ALVAREZ, EXAMINING ATTORNEY

SN 85-231,444. CASELLA WASTE SYSTEMS, INC., RUTLAND, VT. FILED 2-1-2011.



OWNER OF U.S. REG. NOS. 3,655,680 AND 3,655,681.
THE MARK CONSISTS OF AN INCOMPLETE CIRCLE ABOVE THE STYLIZED WORDING "ZERO-SORT HOW RECYCLING GETS DONE".

CLASS 37—CONSTRUCTION AND REPAIR

FOR TRASH WASTE COLLECTION AND WASTE DISPOSAL SERVICES FOR OTHERS (U.S. CLS. 100, 103 AND 106).

CLASS 39—TRANSPORTATION AND STORAGE

FOR GARBAGE WASTE COLLECTION; TRANSPORTATION OF GARBAGE AND TRASH WASTE (U.S. CLS. 100 AND 105).
BRIDGETT SMITH, EXAMINING ATTORNEY

SN 85-232,676. WEISS, WILLIAM, COSTA MESA, CA. FILED 2-2-2011.

L8 APEARL

THE MARK CONSISTS OF STANDARD CHARACTERS WITHOUT CLAIM TO ANY PARTICULAR FONT, STYLE, SIZE, OR COLOR.

CLASS 25—CLOTHING

FOR CLOTHING, NAMELY, TOPS, BOTTOMS, T-SHIRTS, SHORTS, PANTS, JEANS, SHIRTS, SWEATSHIRTS, JACKETS, SWEATERS, VESTS, AND HOODED SWEATSHIRTS; HATS; CAPS; BEANIES; BOXER BRIEFS AND BOXER SHORTS; UNDERWEAR; SOCKS; BELTS; AND FOOTWEAR (U.S. CLS. 22 AND 39).

CLASS 28—TOYS AND SPORTING GOODS

FOR SKATEBOARDS AND STRUCTURAL PARTS THEREFOR, NAMELY, SKATEBOARD DECKS, SKATEBOARD TRUCKS, SKATEBOARD WHEELS, BEARINGS FOR SKATEBOARDS, MOUNTING HARDWARE FOR SKATEBOARDS, GRIP TAPE FOR SKATEBOARDS, AND BUSHINGS FOR SKATEBOARDS (U.S. CLS. 22, 23, 38 AND 50).

NAPOLEON SHARMA, EXAMINING ATTORNEY

SN 85-233,445. CITIGROUP INC., NEW YORK, NY. FILED 2-3-2011.

BANKING ON FINANCIAL INCLUSION

THE MARK CONSISTS OF STANDARD CHARACTERS WITHOUT CLAIM TO ANY PARTICULAR FONT, STYLE, SIZE, OR COLOR.

CLASS 35—ADVERTISING AND BUSINESS

FOR COMMUNITY RELATIONS SERVICES AND COMMUNITY DEVELOPMENT SERVICES, NAMELY, ORGANIZING AND CONDUCTING VOLUNTEER PROGRAMS AND COMMUNITY SERVICE PROJECTS RELATING TO PROMOTING ACCESS TO BANKING AND OTHER FINANCIAL SERVICES IN TRADITIONALLY UNDER-SERVED COMMUNITIES, ORGANIZING PROMOTIONAL AND PUBLIC AWARENESS CAMPAIGNS TO RAISE AWARENESS OF ISSUES AFFECTING ACCESS TO BANKING AND OTHER FINANCIAL SERVICES IN TRADITIONALLY UNDER-SERVED COMMUNITIES, AND ARRANGING COMMERCIAL PARTNERSHIPS AND SPONSORSHIPS TO PROMOTE ACCESS TO BANKING AND OTHER FINANCIAL SERVICES IN TRADITIONALLY UNDER-SERVED COMMUNITIES; ADVERTISING SERVICES; BUSINESS MANAGEMENT AND BUSINESS MANAGEMENT CONSULTING SERVICES; PROMOTING ECONOMIC DEVELOPMENT IN LOW-INCOME COMMUNITIES THROUGHOUT THE UNITED STATES (U.S. CLS. 100, 101 AND 102).

CLASS 36—INSURANCE AND FINANCIAL

FOR FINANCIAL SERVICES, NAMELY, PROVIDING MICROFINANCE LENDING SERVICES TO LOW-INCOME INDIVIDUALS AND SMALL-TO-MEDIUM-SIZED BUSINESSES; BANKING SERVICES; MOBILE BANKING, NAMELY, BANKING SERVICES PROVIDED VIA MOBILE TELECOMMUNICATION DEVICES; CREDIT CARD, DEBIT CARD, AND STORED VALUE PREPAID CARD SERVICES; COMMERCIAL AND CONSUMER LENDING AND FINANCING; REAL ESTATE AND MORTGAGE BROKERAGE; ESTATE TRUST PLANNING AND CONSULTING IN CONNECTION THEREWITH; FIDUCIARY REPRESENTATIVE SERVICES; SECURITIES AND FUND INVESTMENT SERVICES AND FUND INVESTMENT ADVISORY AND CONSULTING SERVICES; SECURITIES BROKERAGE AND TRADING SERVICES FOR OTHERS; FACILITATING SECURE FINANCIAL TRANSACTIONS, NAMELY, ELECTRONIC FUNDS TRANSFERS, ELECTRONIC CASH TRANSACTIONS, ELECTRONIC CREDIT CARD TRANSACTIONS AND ELECTRONIC DEBIT TRANSACTIONS; ELECTRONIC BILL PAYMENT SERVICES, NAMELY, ELECTRONIC PROCESSING AND TRANSMISSION OF BILL PAYMENT DATA; INSURANCE SERVICES, NAMELY, UNDERWRITING, AND BROKERAGE OF PROPERTY, CASUALTY AND LIFE INSURANCE POLICIES AND ANNUITY CONTRACTS; PROVIDING ONLINE INTERACTIVE NEWS AND INFORMATION IN THE BANKING AND FINANCIAL INDUSTRIES PROVIDED VIA A GLOBAL COMPUTER NETWORK (U.S. CLS. 100, 101 AND 102).

RUSS HERMAN, EXAMINING ATTORNEY

SN 85-233,610. ROCKIN' JUMP INC., DBA ROCKIN' JUMP, DUBLIN, CA. FILED 2-3-2011.



THE MARK CONSISTS OF THE WORD "ROCKIN'" IN DISTRESSED BLOCK LETTERING WITH THE WORD "JUMP" UNDERNEATH IT IN SLIGHTLY LARGER SOLID BLOCK LETTERING. TO THE LEFT OF THE WORDS "ROCKIN' JUMP" IS A STYLIZED FROG WITH ITS LIMBS SPREAD OUT AND WITH ITS RIGHT HIND LEG DANGLING OFF OF THE HOOK OF THE LETTER "J" IN THE WORD "JUMP". THE STYLIZED FROG ALSO HAS A PROMINENT HOLLOW EYEBALL THAT STANDS OUT ON THE SOLID COLORED FROG.

CLASS 25—CLOTHING

FOR ATHLETIC APPAREL, NAMELY, SHIRTS, PANTS, JACKETS, FOOTWEAR, HATS AND CAPS, ATHLETIC UNIFORMS (U.S. CLS. 22 AND 39).

CLASS 41—EDUCATION AND ENTERTAINMENT

FOR CHILDREN'S ENTERTAINMENT AND AMUSEMENT CENTERS, NAMELY, INTERACTIVE PLAY AREAS (U.S. CLS. 100, 101 AND 107).

IRA J. GOODSID, EXAMINING ATTORNEY

SN 85-233,785. CLIMATE CYCLE, CHICAGO, IL. FILED 2-3-2011.

Climate Cycle

THE MARK CONSISTS OF STANDARD CHARACTERS WITHOUT CLAIM TO ANY PARTICULAR FONT, STYLE, SIZE, OR COLOR.

CLASS 25—CLOTHING

FOR CLOTHING, NAMELY, T-SHIRTS (U.S. CLS. 22 AND 39).
FIRST USE 3-0-2009; IN COMMERCE 3-0-2009.

CLASS 36—INSURANCE AND FINANCIAL

FOR CHARITABLE FUNDRAISING SERVICES (U.S. CLS. 100, 101 AND 102).
FIRST USE 12-0-2007; IN COMMERCE 12-0-2007.

CLASS 41—EDUCATION AND ENTERTAINMENT

FOR EDUCATION SERVICES, NAMELY, PROVIDING CLASSES, SEMINARS, WORKSHOPS ON ENVIRONMENTAL ISSUES, GLOBAL WARMING, RENEWABLE ENERGY, AND HEALTH; ORGANIZING, ARRANGING, AND CONDUCTING CYCLING EVENTS; ORGANIZING AND CONDUCTING BICYCLE RIDE EVENT THE PROCEEDS OF WHICH ARE DONATED TO FUND ENVIRONMENTAL EDUCATIONAL PROGRAMS AND INSTALLATION OF RENEWABLE ENERGY AND ENERGY EFFICIENCY PROJECTS IN SCHOOLS; SOCIAL CLUB SERVICES, NAMELY, ARRANGING, ORGANIZING, AND HOSTING SOCIAL EVENTS FOR CYCLE CLUB AND ASSOCIATION MEMBERS; EDUCATIONAL SERVICES, NAMELY, CONDUCTING OUTDOOR FIELD TRIPS IN THE FIELD OF RENEWABLE ENERGY, ENERGY EFFICIENCY, URBAN AGRICULTURE, AND ENVIRONMENTAL PROTECTION (U.S. CLS. 100, 101 AND 107).

FIRST USE 4-0-2007; IN COMMERCE 5-0-2007.

B. PARADEWELAI, EXAMINING ATTORNEY

SN 85-234,521. THE E GROUP, INC., RESTON, VA. FILED 2-4-2011.

RECOGNITION. MADE SIMPLE.

THE MARK CONSISTS OF STANDARD CHARACTERS WITHOUT CLAIM TO ANY PARTICULAR FONT, STYLE, SIZE, OR COLOR.

NO CLAIM IS MADE TO THE EXCLUSIVE RIGHT TO USE "RECOGNITION", APART FROM THE MARK AS SHOWN.

CLASS 35—ADVERTISING AND BUSINESS

FOR CONDUCTING EMPLOYEE INCENTIVE AWARD PROGRAMS TO PROMOTE PROFESSIONAL GROWTH AND DEVELOPMENT THROUGH RECOGNITION OF EMPLOYEE ACHIEVEMENTS IN ORDER TO ENGAGE WORKFORCES TO MAXIMIZE PERFORMANCE; PROVIDING RECOGNITION AND REWARD PROGRAMS IN THE NATURE OF EMPLOYEE INCENTIVE AWARD PROGRAMS TO PROMOTE EMPLOYEE RETENTION AND EMPLOYEE QUALITY AND PRODUCTIVITY PERFORMANCE; CONSULTING SERVICES IN THE FIELD OF HUMAN RESOURCES DEVELOPMENT FOR THE PROMOTION OF EMPLOYEE RETENTION AND INCREASED PRODUCTIVITY FOR EMPLOYEES AND EMPLOYERS, NAMELY, DESIGNING PROGRAMS TO ENHANCE A COMPANY'S CORPORATE CULTURE (U.S. CLS. 100, 101 AND 102).

CLASS 41—EDUCATION AND ENTERTAINMENT

FOR PROVIDING RECOGNITION AND INCENTIVES BY WAY OF AWARDS TO DEMONSTRATE EXCELLENCE IN THE FIELDS OF EMPLOYEE SERVICE AND EMPLOYEE PRODUCTIVITY (U.S. CLS. 100, 101 AND 107).

TARA PATE, EXAMINING ATTORNEY

SN 85-234,525. GROBET FILE COMPANY OF AMERICA, INC., CARLSTADT, NJ. FILED 2-4-2011.

BEADCRAFT

THE MARK CONSISTS OF STANDARD CHARACTERS WITHOUT CLAIM TO ANY PARTICULAR FONT, STYLE, SIZE, OR COLOR.

CLASS 6—METAL GOODS

FOR JEWELER'S BEADING TOOLS AND STRINGING SUPPLIES, NAMELY, WIRE (U.S. CLS. 2, 12, 13, 14, 23, 25 AND 50).

FIRST USE 2-14-2011; IN COMMERCE 2-14-2011.

CLASS 8—HAND TOOLS

FOR JEWELER'S BEADING TOOLS AND STRINGING SUPPLIES, NAMELY, PLIERS, WIRE CUTTERS AND TWEEZERS (U.S. CLS. 23, 28 AND 44).

CLASS 22—CORDAGE AND FIBERS

FOR JEWELER'S BEADING TOOLS AND STRINGING SUPPLIES, NAMELY, CABLE CORDS (U.S. CLS. 1, 2, 7, 19, 22, 42 AND 50).

CLASS 23—YARNS AND THREADS

FOR JEWELER'S BEADING TOOLS AND STRINGING SUPPLIES, NAMELY, THREADS (U.S. CL. 43).

FIRST USE 2-14-2011; IN COMMERCE 2-14-2011.

CLASS 26—FANCY GOODS

FOR JEWELER'S BEADING TOOLS AND STRINGING SUPPLIES, NAMELY, NEEDLES (U.S. CLS. 37, 39, 40, 42 AND 50).

FIRST USE 2-14-2011; IN COMMERCE 2-14-2011.
CAROLINE WOOD, EXAMINING ATTORNEY

SN 85-234,665. THE E GROUP, INC., RESTON, VA. FILED 2-4-2011.

LOGO PRODUCTS. MADE SIMPLE.

THE MARK CONSISTS OF STANDARD CHARACTERS WITHOUT CLAIM TO ANY PARTICULAR FONT, STYLE, SIZE, OR COLOR.

NO CLAIM IS MADE TO THE EXCLUSIVE RIGHT TO USE "LOGO PRODUCTS", APART FROM THE MARK AS SHOWN.

CLASS 35—ADVERTISING AND BUSINESS

FOR CONDUCTING EMPLOYEE INCENTIVE AWARD PROGRAMS TO PROMOTE PROFESSIONAL GROWTH AND DEVELOPMENT THROUGH RECOGNITION OF EMPLOYEE ACHIEVEMENTS IN ORDER TO ENGAGE WORKFORCES TO MAXIMIZE PERFORMANCE; PROVIDING RECOGNITION AND REWARD PROGRAMS IN THE NATURE OF EMPLOYEE INCENTIVE AWARD PROGRAMS TO PROMOTE EMPLOYEE RETENTION AND EMPLOYEE QUALITY AND PRODUCTIVITY PERFORMANCE; CONSULTING SERVICES IN THE FIELD OF HUMAN RESOURCES DEVELOPMENT FOR THE PROMOTION OF EMPLOYEE RETENTION AND INCREASED PRODUCTIVITY FOR EMPLOYEES AND EMPLOYERS, NAMELY, DESIGNING PROGRAMS TO ENHANCE A COMPANY'S CORPORATE CULTURE; BRAND POSITIONING SERVICES; MARKETING AND BRANDING SERVICES, NAMELY, PERFORMING BRAND STRATEGY OF COMPANY LOGOS (U.S. CLS. 100, 101 AND 102).

CLASS 41—EDUCATION AND ENTERTAINMENT

FOR PROVIDING RECOGNITION AND INCENTIVES BY WAY OF AWARDS TO DEMONSTRATE EXCELLENCE IN THE FIELDS OF EMPLOYEE SERVICE AND EMPLOYEE PRODUCTIVITY (U.S. CLS. 100, 101 AND 107).

TARA PATE, EXAMINING ATTORNEY

SN 85-235,877. SHEDRAIN CORPORATION, PORTLAND, OR. FILED 2-7-2011.

GELLAS

THE MARK CONSISTS OF STANDARD CHARACTERS WITHOUT CLAIM TO ANY PARTICULAR FONT, STYLE, SIZE, OR COLOR.

OWNER OF U.S. REG. NOS. 2,930,900 AND 3,951,471.

CLASS 8—HAND TOOLS

FOR PLIABLE HANDLES FOR HAND TOOLS, NAMELY, AWLS, DRILLS, FILES, HAMMERS, PLIERS, SAWS, SCREWDRIVERS, SOCKET SETS, WRENCHES (U.S. CLS. 23, 28 AND 44).

CLASS 16—PAPER GOODS AND PRINTED MATTER

FOR PLIABLE HANDLES FOR PAINT BRUSHES (U.S. CLS. 2, 5, 22, 23, 29, 37, 38 AND 50).

CLASS 21—HOUSEWARES AND GLASS

FOR PLIABLE HANDLES FOR BARBEQUE TOOLS, NAMELY, FORKS, TONGS, TURNERS, BASTING BRUSHES, BRUSHES FOR CLEANING GRILLS (U.S. CLS. 2, 13, 23, 29, 30, 33, 40 AND 50).

DAVID I, EXAMINING ATTORNEY

SN 85-239,109. MARK FRIEL, CALGARY, ALBERTA, CANADA, FILED 2-10-2011.

SN 85-240,114. THE INTERNATIONAL ASSOCIATION OF CLAN MACINNES, INC., SHARON, MA. FILED 2-11-2011.

SPACEMATS

THE MARK CONSISTS OF STANDARD CHARACTERS WITHOUT CLAIM TO ANY PARTICULAR FONT, STYLE, SIZE, OR COLOR.

CLASS 16—PAPER GOODS AND PRINTED MATTER

FOR MAT BOARDS; PAPER FLOOR MATS; PAPER MATS; PAPER PLACE MATS (U.S. CLS. 2, 5, 22, 23, 29, 37, 38 AND 50).

CLASS 24—FABRICS

FOR PLACE MATS OF TEXTILE MATERIAL; PLACE MATS, NOT OF PAPER; PLASTIC PLACE MATS; TEXTILE PLACE MATS; VINYL PLACE MATS (U.S. CLS. 42 AND 50).

ERIN FALK, EXAMINING ATTORNEY



THE COLOR(S) GREEN, YELLOW, RED, BLUE, BLACK, WHITE, GOLD, SILVER AND BROWN IS/ARE CLAIMED AS A FEATURE OF THE MARK.

THE MARK CONSISTS OF A DESIGN OF A HERALDIC COAT OF ARMS AND BANNER WITH WORDING. THE MARK IS A SHIELD DIVIDED INTO QUADRANTS BY A GREEN CROSS. FOUR STYLIZED CROSSLETS APPEAR WITHIN THE GREEN CROSS. A YELLOW CASTLE, WITH RED WINDOWS AND A RED DOOR APPEARS IN THE SHIELD'S UPPER LEFT QUADRANT. THE BACKGROUND OF UPPER LEFT SHIELD QUADRANT IS COLORED BLUE. A BLACK, WILD BOAR WITH WHITE TUSKS AND A RED TONGUE APPEARS IN THE LOWER LEFT QUADRANT OF THE SHIELD. THE BACKGROUND OF THE LOWER LEFT SHIELD QUADRANT IS COLORED GOLD. A GOLD SALMON APPEARS IN THE LOWER RIGHT QUADRANT OF THE SHIELD. THE BACKGROUND OF THE LOWER RIGHT SHIELD QUADRANT IS COLORED BLUE. A GREEN GALLEY SHIP WITH RED OARS, AND RED AND WHITE PENNANTS APPEARS IN THE UPPER RIGHT QUADRANT OF THE SHIELD. THE BACKGROUND OF THE UPPER RIGHT SHIELD QUADRANT IS GOLD. ABOVE THE SHIELD APPEARS A SILVER KNIGHT'S HELMET WITH A RED INTERIOR. ABOVE THE KNIGHT'S HELMET APPEARS A BLUE AND GOLD WREATH. TO BOTH SIDES OF THE HELMET APPEAR STYLIZED LEAVES COLORED BLUE AND GOLD. ARISING FROM THE WREATH IS AN ARM AND FIST. THE ARM IS CLOTHED IN A GREEN, BLUE AND RED SLEEVE OF A TARTAN DESIGN. THE FIST IS CLENCHED OVER A BROWN BOW. A WHITE SCROLL WITH A BLACK BORDER APPEARS ABOVE THE BOW. IN THE SCROLL WITH BLACK LETTER APPEARS THE WORDING "MACAONGHAIS A-RITHIS". THE COLOR RED APPEARS ON THE BACK SIDE OF THE SCROLL.

THE ENGLISH TRANSLATION OF "MACAONGHAIS A-RITHIST" IN THE MARK IS "AGAIN MACINNES".

CLASS 14—JEWELRY

FOR BROOCHES; COSTUME JEWELRY; JEWELRY; JEWELRY BROOCHES; JEWELRY FOR ATTACHMENT TO CLOTHING; JEWELRY PINS FOR USE ON HATS; LAPEL PINS; ORNAMENTAL LAPEL PINS; ORNAMENTAL PINS; PINS BEING JEWELRY; TIE PINS (U.S. CLS. 2, 27, 28 AND 50).

FIRST USE 5-2-2005; IN COMMERCE 6-3-2005.

SN 85-239,740. SST FOAM, LLC, ATLANTA, GA. FILED 2-11-2011.

TREADRITE

THE MARK CONSISTS OF STANDARD CHARACTERS WITHOUT CLAIM TO ANY PARTICULAR FONT, STYLE, SIZE, OR COLOR.

CLASS 1—CHEMICALS

FOR POLYMER COMPOSITION USED IN THE MANUFACTURE OF COMMERCIAL AND INDUSTRIAL GOODS, NAMELY, BACKING FOR RUGS AND MATS (U.S. CLS. 1, 5, 6, 10, 26 AND 46).

CLASS 27—FLOOR COVERINGS

FOR BACKING FOR RUGS AND FLOOR MATS (U.S. CLS. 19, 20, 37, 42 AND 50).

TARA PATE, EXAMINING ATTORNEY

CLASS 16—PAPER GOODS AND PRINTED MATTER

FOR BALL POINT PENS; BALL-POINT PENS; BALL-POINT PENS; COLOURED PENS; ENVELOPE PAPER; ENVELOPE PAPERS; ENVELOPES; ENVELOPES FOR STATIONERY USE; FABRIC GIFT BAGS; INK PENS; MARKING PENS; NOTE CARDS; NOTE PAPER; NOTE PAPERS; OFFICE STATIONERY; PAPER STATIONERY; PENS; PRINTED MATTER, NAMELY, PAPER SIGNS, BOOKS, MANUALS, CURRICULUM, NEWSLETTERS, INFORMATIONAL CARDS AND BROCHURES IN THE FIELD OF MACINNES FAMILY HISTORY; SOCIAL NOTE CARDS; STATIONERY; STATIONERY WRITING PAPER AND ENVELOPES (U.S. CLS. 2, 5, 22, 23, 29, 37, 38 AND 50).

FIRST USE 5-2-2005; IN COMMERCE 6-3-2005.

CLASS 25—CLOTHING

FOR ATHLETIC APPAREL, NAMELY, SHIRTS, PANTS, JACKETS, FOOTWEAR, HATS AND CAPS, ATHLETIC UNIFORMS; BASEBALL CAPS; BASEBALL CAPS AND HATS; BELTS; BODY SHIRTS; CAPS WITH VISORS; COLLARED SHIRTS; GOLF CAPS; HATS; JACKETS; JERSEYS; LONG-SLEEVED SHIRTS; OPEN-NECKED SHIRTS; OUTER JACKETS; OVER SHIRTS; POLO SHIRTS; RAIN JACKETS; RAINPROOF JACKETS; SHELL JACKETS; SHIRTS; SHIRTS AND SHORT-SLEEVED SHIRTS; SHORT-SLEEVED OR LONG-SLEEVED T-SHIRTS; SHORT-SLEEVED SHIRTS; SPORT SHIRTS; SPORTS JACKETS; SWEAT JACKETS; SWEAT SHIRTS; T-SHIRTS; TEE SHIRTS; WEARABLE GARMENTS AND CLOTHING, NAMELY, SHIRTS; WIND RESISTANT JACKETS; WIND-JACKETS (U.S. CLS. 22 AND 39).

FIRST USE 5-2-2005; IN COMMERCE 6-3-2005.
KATHERINE CONNOLLY, EXAMINING ATTORNEY

CLASS 35—ADVERTISING AND BUSINESS

FOR BUSINESS CONSULTING SERVICES IN THE FIELD OF ENERGY EFFICIENCY; CONSULTING SERVICES IN THE FIELDS OF ENERGY USAGE MANAGEMENT AND ENERGY EFFICIENCY; CONSULTING SERVICES IN THE FIELD OF ENERGY EFFICIENCY, NAMELY, CONSULTING REGARDING ENERGY CONSUMPTION, ENERGY BENCHMARKING, AND RESOURCES CONSERVATION TO IMPROVE ENERGY EFFICIENCY AND ENERGY USAGE MANAGEMENT; CONSULTING IN THE FIELD OF ENERGY EFFICIENCY AND ENERGY USAGE MANAGEMENT, NAMELY, CONSULTING REGARDING THE USE OF ENERGY TECHNOLOGY, CLEAN TECHNOLOGY, ALTERNATIVE ENERGY AND ENERGY INFRASTRUCTURE TO IMPROVE ENERGY EFFICIENCY AND REDUCE ENERGY CONSUMPTION; DESIGNING AND IMPLEMENTING ENERGY EFFICIENCY PROGRAMS FOR BUSINESSES, TO REDUCE ENERGY CONSUMPTION; ANALYSIS OF ENERGY USAGE FOR BUSINESSES FOR THE PURPOSES OF DETERMINING ENERGY EFFICIENCY AND ENERGY USAGE MANAGEMENT; CONSULTING SERVICES IN THE FIELD OF ENERGY USAGE MANAGEMENT AND IMPROVEMENT OF ENERGY EFFICIENCY; CONSULTING SERVICES PROVIDED TO GOVERNMENTS, UTILITIES AND ENERGY USERS IN THE FIELD OF ENERGY EFFICIENCY AND ENERGY RESOURCE MANAGEMENT; CONSULTING SERVICES IN THE FIELDS OF ENERGY AND ENVIRONMENTAL POLICIES DESIGNED TO INCREASE ENERGY EFFICIENCY AND MANAGE ENERGY USAGE; ASSESSMENT OF ENERGY SYSTEMS AND ENERGY USE FOR THE PURPOSE OF DETERMINING ENERGY EFFICIENCY AND MANAGING ENERGY USAGE (U.S. CLS. 100, 101 AND 102).

FIRST USE 4-1-1995; IN COMMERCE 5-1-1995.

CLASS 37—CONSTRUCTION AND REPAIR

FOR ENERGY ASSESSMENT AND ANALYSIS SERVICES FOR THE PURPOSE OF DETERMINING CONSTRUCTION IMPROVEMENTS NEEDED TO IMPROVE ENERGY EFFICIENCY (U.S. CLS. 100, 103 AND 106).

FIRST USE 4-0-1996; IN COMMERCE 5-0-1996.

CLASS 40—MATERIAL TREATMENT

FOR CONSULTING SERVICES IN THE FIELDS OF RENEWABLE ENERGY GENERATION EQUIPMENT AND OF ALTERNATIVE, RENEWABLE, AND CLEAN ENERGY GENERATION AND PRODUCTION (U.S. CLS. 100, 103 AND 106).

FIRST USE 4-0-1996; IN COMMERCE 5-0-1996.

CLASS 42—SCIENTIFIC AND COMPUTER SERVICES

FOR ENGINEERING SERVICES IN THE FIELD OF ENERGY EFFICIENCY; DESIGN FOR OTHERS IN THE FIELD OF ENERGY EFFICIENCY IMPROVEMENTS FOR BUILDINGS IN THE NATURE OF LIGHTING, HEATING, COOLING, ENVIRONMENTAL CONTROL SYSTEMS, AND INDUSTRIAL PROCESSES AND EQUIPMENT; CONSULTING SERVICES RELATED TO THE DESIGN OF ENERGY EFFICIENT AND SUSTAINABLE BUILDINGS; TECHNOLOGICAL CONSULTING SERVICES IN THE FIELDS OF RENEWABLE ENERGY; ENERGY MEASUREMENT SERVICES TO IMPROVE ENERGY EFFICIENCY; CONSULTING SERVICES FOR GOVERNMENTS AND UTILITIES IN THE FIELD OF DEVELOPMENT OF RENEWABLE ENERGY RESOURCES; MONITORING THE FUNCTIONING AND USE OF ENERGY-USING EQUIPMENT IN THE NATURE OF LIGHTING, HEATING, COOLING, AND ENVIRONMENTAL CONTROL SYSTEMS, FOR THE PURPOSE OF MEASURING ENERGY USE; CONSULTING IN THE FIELD OF INFRASTRUCTURE DEVELOPMENT AS IT RELATES TO ENERGY USE (U.S. CLS. 100 AND 101).

FIRST USE 4-1-1995; IN COMMERCE 5-1-1995.
LAURA KOVALSKY, EXAMINING ATTORNEY

SN 85-240,469. ENERGY AND RESOURCE SOLUTIONS, INC, NORTH ANDOVER, MA. FILED 2-11-2011.

ENERGY & RESOURCE SOLUTIONS

THE MARK CONSISTS OF STANDARD CHARACTERS WITHOUT CLAIM TO ANY PARTICULAR FONT, STYLE, SIZE, OR COLOR.

NO CLAIM IS MADE TO THE EXCLUSIVE RIGHT TO USE "ENERGY", APART FROM THE MARK AS SHOWN. SEC. 2(F).

SN 85-240,540. MONSTER MOUSE GRILLHOUSE, LLC,
WALLINGFORD, CT. FILED 2-11-2011.



THE COLOR(S) RED, BURGUNDY, ORANGE, GREY, BLUE, WHITE, BLACK, YELLOW, BEIGE, PINK AND BROWN IS/ARE CLAIMED AS A FEATURE OF THE MARK.

THE MARK CONSISTS OF THE WORDS "MONSTER MOUSE" AND "GIVE CHEEZE A CHANCE" ARE IN A CIRCLE IN YELLOW OUTLINED IN RED WITH A WHITE BACKGROUND. THE CIRCLES OUTER RIM IS RED WITH A GREY SHADING AND AN INNER CIRCLES RIM IS BLUE. IN THE CENTER OF A RED AND BURGUNDY BACKGROUND WITH ORANGE FLAMES OUTLINED IN BLUE IS A MOUSE WITH A GREY HEAD WITH INNER PINK EARS, A BEIGE AND BROWN BODY WITH A BLACK TIPPED NOSE. HE IS DRESSED IN A WHITE T-SHIRT AND A BLACK VEST WITH A YELLOW "MM" BELT BUCKLE. HE HAS A TATTOO THAT SAYS "I IN BLACK (RED HEART MEANING LOVE) CHEESE IN BLACK". IN HIS RIGHT HAND HE HAS A GREY SPATULA FLIPPING A GRILLED CHEESE SANDWICH AND IN THE LEFT HAND HE HAS A GREY PITCH FORK WITH A WEDGE OF CHEESE IN IT. HE HAS A RED BANDANA WITH WHITE SKULLS. HE HAS WILD BLUE EYES AND BRIGHT WHITE TEETH. THE OUTLINE OF THE ENTIRE MOUSE IS BLACK

CLASS 16—PAPER GOODS AND PRINTED MATTER

FOR CARDBOARD CARRIERS FOR FOOD AND BEVERAGES (U.S. CLS. 2, 5, 22, 23, 29, 37, 38 AND 50).

CLASS 25—CLOTHING

FOR TOPS (U.S. CLS. 22 AND 39).

CLASS 35—ADVERTISING AND BUSINESS

FOR STREET VENDOR SERVICES FEATURING FOOD (U.S. CLS. 100, 101 AND 102).
ALICE BENMAMAN, EXAMINING ATTORNEY

SN 85-240,677. PG TRUST, MONA VALE, AUSTRALIA,
FILED 2-11-2011.

THE HEALTH & HAPPINESS DIGEST

THE MARK CONSISTS OF STANDARD CHARACTERS WITHOUT CLAIM TO ANY PARTICULAR FONT, STYLE, SIZE, OR COLOR.

NO CLAIM IS MADE TO THE EXCLUSIVE RIGHT TO USE "HEALTH" AND "DIGEST", APART FROM THE MARK AS SHOWN.

CLASS 9—ELECTRICAL AND SCIENTIFIC APPARATUS

FOR DOWNLOADABLE ELECTRONIC NEWSLETTERS DELIVERED BY E-MAIL IN THE FIELD OF HEALTH; DOWNLOADABLE ELECTRONIC NEWSLETTERS IN THE FIELD OF HEALTH (U.S. CLS. 21, 23, 26, 36 AND 38).

CLASS 41—EDUCATION AND ENTERTAINMENT

FOR PROVIDING ON-LINE NEWSLETTERS IN THE FIELD OF HEALTH (U.S. CLS. 100, 101 AND 107).
MICHELE SWAIN, EXAMINING ATTORNEY

SN 85-240,862. CATALYST REPOSITORY SYSTEMS, INC.,
DENVER, CO. FILED 2-12-2011.



OWNER OF U.S. REG. NOS. 3,191,695, 3,260,092 AND 3,285,592.

THE COLOR(S) BLUE AND ORANGE IS/ARE CLAIMED AS A FEATURE OF THE MARK.

THE MARK CONSISTS OF THE WORD "CATALYST" IN BLUE AND THE WORD "INSIGHT" IN ORANGE WITH AN ORANGE LIGHTNING BOLT ABOVE THE SECOND "I".

CLASS 35—ADVERTISING AND BUSINESS

FOR DATA PROCESSING SERVICES; PREPARING CUSTOM BUSINESS REPORTS (U.S. CLS. 100, 101 AND 102).

CLASS 42—SCIENTIFIC AND COMPUTER SERVICES

FOR APPLICATION SERVICE PROVIDER (ASP) AND SOFTWARE AS A SERVICE (SAAS) PROVIDER SERVICES FEATURING SOFTWARE FOR PROVIDING ON-LINE DOCUMENT PROCESSING, ANALYTICS, SEARCH, REVIEW AND PRODUCTION BY ELECTRONIC MEANS FOR USE IN THE FIELDS OF ELECTRONIC DISCOVERY, LITIGATION SUPPORT, REGULATORY AND INTERNAL INVESTIGATIONS AND FINANCIAL AND MERGER AND ACQUISITION DUE DILIGENCE; COMPUTER PROJECT MANAGEMENT SERVICES; COMPUTER PROJECT MANAGEMENT SERVICES, NAMELY, DESIGNING WORKFLOWS, DATA LOADING, PREPARING AND PRESENTING CUSTOM REPORTS REGARDING THE PERFORMANCE OF AND RESULTS PRODUCED BY THE SOFTWARE APPLICATION AND REPORTS REGARDING THE PROGRESS OF THE COMPUTER PROJECT MANAGEMENT, CUSTOMIZATION OF SOFTWARE, AND QUALITY CONTROL FOR OTHERS RELATED TO ELECTRONIC DOCUMENT PROCESSING, ANALYTICS, SEARCH, REVIEW AND PRODUCTION FOR USE IN THE FIELDS OF ELECTRONIC DISCOVERY, LITIGATION SUPPORT, REGULATORY AND INTERNAL INVESTIGATIONS AND FINANCIAL AND MERGER AND ACQUISITION DUE DILIGENCE; SEARCHING, RETRIEVING, AND ORGANIZING INFORMATION, SITES, AND OTHER RESOURCES AVAILABLE ON COMPUTER NETWORKS FOR OTHERS FOR USE IN THE FIELDS OF ELECTRONIC DISCOVERY, LITIGATION SUPPORT, REGULATORY INVESTIGATIONS AND FINANCIAL AND MERGER AND ACQUISITION DUE DILIGENCE (U.S. CLS. 100 AND 101).
MICHAEL SOUDERS, EXAMINING ATTORNEY

SN 85-240,863. CATALYST REPOSITORY SYSTEMS, INC., DENVER, CO. FILED 2-12-2011.

CATALYST INSIGHT

THE MARK CONSISTS OF STANDARD CHARACTERS WITHOUT CLAIM TO ANY PARTICULAR FONT, STYLE, SIZE, OR COLOR.

OWNER OF U.S. REG. NOS. 3,191,695, 3,260,092 AND 3,285,592.

CLASS 35—ADVERTISING AND BUSINESS

FOR DATA PROCESSING SERVICES; PREPARING CUSTOM BUSINESS REPORTS (U.S. CLS. 100, 101 AND 102).

CLASS 42—SCIENTIFIC AND COMPUTER SERVICES

FOR APPLICATION SERVICE PROVIDER (ASP) AND SOFTWARE AS A SERVICE (SAAS) PROVIDER SERVICES FEATURING SOFTWARE FOR PROVIDING ONLINE DOCUMENT PROCESSING, ANALYTICS, SEARCH, REVIEW AND PRODUCTION BY ELECTRONIC MEANS FOR USE IN THE FIELDS OF ELECTRONIC DISCOVERY, LITIGATION SUPPORT, REGULATORY AND INTERNAL INVESTIGATIONS AND FINANCIAL AND MERGER AND ACQUISITION DUE DILIGENCE; COMPUTER PROJECT MANAGEMENT SERVICES; COMPUTER PROJECT MANAGEMENT SERVICES, NAMELY, DESIGNING WORKFLOWS, DATA LOADING, PREPARING AND PRESENTING CUSTOM REPORTS REGARDING THE PERFORMANCE OF AND RESULTS PRODUCED BY THE SOFTWARE APPLICATION AND REPORTS REGARDING THE PROGRESS OF THE COMPUTER PROJECT MANAGEMENT, CUSTOMIZATION OF SOFTWARE, AND QUALITY CONTROL FOR OTHERS RELATED TO ELECTRONIC DOCUMENT PROCESSING, ANALYTICS, SEARCH, REVIEW AND PRODUCTION FOR USE IN THE FIELDS OF ELECTRONIC DISCOVERY, LITIGATION SUPPORT, REGULATORY AND INTERNAL INVESTIGATIONS AND FINANCIAL AND MERGER AND ACQUISITION DUE DILIGENCE; SEARCHING, RETRIEVING, AND ORGANIZING INFORMATION, SITES, AND OTHER RESOURCES AVAILABLE ON COMPUTER NETWORKS FOR OTHERS FOR USE IN THE FIELDS OF ELECTRONIC DISCOVERY, LITIGATION SUPPORT, REGULATORY INVESTIGATIONS AND FINANCIAL AND MERGER AND ACQUISITION DUE DILIGENCE (U.S. CLS. 100 AND 101).

MICHAEL SOUDERS, EXAMINING ATTORNEY

SN 85-241,741. MOLKEREI ALOIS MÜLLER GMBH & CO. KG, ARETSRIED, FED REP GERMANY, FILED 2-14-2011.



THE COLOR(S) RED, BLACK AND WHITE IS/ARE CLAIMED AS A FEATURE OF THE MARK.

THE MARK CONSISTS OF THE LITERAL ELEMENT "MÜLLER" SHOWN IN WHITE STYLIZED LOWER CASE LETTERS OUTLINED IN BLACK, REVERSED OUT OF A RED BACKGROUND INCLUDED IN A GENERALLY RECTANGULAR GEOMETRIC SHAPE WITH BEVELED EDGES.

CLASS 29—MEATS AND PROCESSED FOODS

FOR MILK, BUTTERMILK, SOUR MILK AND MILK PRODUCTS, NAMELY, BUTTER, CHEESE, CREAM, YOGURT, KEFIR MADE FROM MILK WITH SPECIFIC KEFIR CULTURES CONSISTING OF KEFIR BULBS, BUTTERMILK, POWDERED MILK, DAIRY-BASED FOOD BEVERAGES; PROCESSED BEAN CURD (U.S. CL. 46).

CLASS 30—STAPLE FOODS

FOR MILKSHAKES, FROZEN YOGURT, FROZEN CONFECTIONS CONTAINING YOGURT, BEAN CURD AND CREAM; ICE CREAM (U.S. CL. 46).

CLASS 32—LIGHT BEVERAGES

FOR MINERAL WATER, CARBONIZED DRINKING WATER, SOFT DRINKS, FRUIT DRINKS AND FRUIT JUICES (U.S. CLS. 45, 46 AND 48).

ARETHA SOMERVILLE, EXAMINING ATTORNEY

SN 85-242,036. MARSO, MICHAEL R., DOUGLAS, WY. FILED 2-14-2011.



NO CLAIM IS MADE TO THE EXCLUSIVE RIGHT TO USE "WY", APART FROM THE MARK AS SHOWN.

THE COLOR(S) BROWN AND GOLD IS/ARE CLAIMED AS A FEATURE OF THE MARK.

THE MARK CONSISTS OF A BROWN LETTER "I" FOLLOWED BY A GOLD HEART WITH A BROWN "W" AND "Y" DIRECTLY UNDERNEATH THE "I" AND THE HEART, RESPECTIVELY. THE LITERAL PORTION OF THE MARK IS IN STYLIZED FONT.

CLASS 16—PAPER GOODS AND PRINTED MATTER

FOR BUMPER STICKERS (U.S. CLS. 2, 5, 22, 23, 29, 37, 38 AND 50).

CLASS 25—CLOTHING

FOR ATHLETIC APPAREL, NAMELY, SHIRTS, PANTS, JACKETS, FOOTWEAR, HATS AND CAPS, ATHLETIC UNIFORMS (U.S. CLS. 22 AND 39).

KAREN SEVERSON, EXAMINING ATTORNEY

SN 85-242,868. ROSWELL PARK CANCER INSTITUTE CORPORATION, BUFFALO, NY. FILED 2-15-2011.



OWNER OF U.S. REG. NOS. 2,286,574, 3,775,222 AND OTHERS.

NO CLAIM IS MADE TO THE EXCLUSIVE RIGHT TO USE "CANCER SURVIVORS PROGRAM", APART FROM THE MARK AS SHOWN.

THE MARK CONSISTS OF THE WORDS "SUPPORT FOR LIFE" WITH THE WORDS "SUPPORT FOR" ABOVE A LINE AND THE LINE RUNNING INTO THE WORD "LIFE" AND UNDERNEATH ARE THE WORDS "THE CANCER SURVIVORS PROGRAM OF ROSWELL PARK".

CLASS 35—ADVERTISING AND BUSINESS

FOR PROMOTING PUBLIC AWARENESS AS TO THE CAUSES, TREATMENT AND PREVENTION OF ADULT AND PEDIATRIC CANCER (U.S. CLS. 100, 101 AND 102).

CLASS 36—INSURANCE AND FINANCIAL

FOR CHARITABLE FUNDRAISING SERVICES (U.S. CLS. 100, 101 AND 102).

CLASS 41—EDUCATION AND ENTERTAINMENT

FOR EDUCATIONAL SERVICES, NAMELY, WORKSHOPS AND SEMINARS ABOUT THE CAUSES AND TREATMENTS OF ADULT AND PEDIATRIC CANCER, PSYCHOSOCIAL ASPECTS OF THE EFFECTS OF ADULT AND PEDIATRIC CANCER IN SELF OR LOVED ONES AND DISTRIBUTION OF EDUCATIONAL AND COURSE MATERIALS IN CONNECTION THEREWITH (U.S. CLS. 100, 101 AND 107).

WILLIAM VERHOSEK, EXAMINING ATTORNEY

SN 85-243,602. MESSIAH HOME, DBA MESSIAH VILLAGE, MECHANICSBURG, PA. FILED 2-16-2011.

Messiah LifeWays

THE MARK CONSISTS OF STANDARD CHARACTERS WITHOUT CLAIM TO ANY PARTICULAR FONT, STYLE, SIZE, OR COLOR.

CLASS 41—EDUCATION AND ENTERTAINMENT

FOR EDUCATION SERVICES, NAMELY, PROVIDING SEMINARS AND CLASSES FOR SENIOR ADULTS IN THE FIELD OF MENTAL, CULTURAL, AND SPIRITUAL STUDY FOR PROMOTING THEIR OVERALL WELLNESS, EXCLUDING SEMINARS, CLASSES AND CONCERTS AT WHICH THE PATRONS OR ATTENDEES PARTICIPATE BY SINGING, AND ALSO EXCLUDING CONFERENCES, SEMINARS AND CLASSES IN THE FIELD OF RELIGION; CONDUCTING SOCIAL ENTERTAINMENT EVENTS FOR SENIOR ADULTS WITH OPPORTUNITIES TO ENGAGE IN MENTAL, CULTURAL, SPIRITUAL ACTIVITIES PROMOTING THEIR OVERALL WELLNESS, EXCLUDING SOCIAL ENTERTAINMENT EVENTS AT WHICH THE PATRONS OR ATTENDEES PARTICIPATE BY SINGING, AND ALSO EXCLUDING SOCIAL ENTERTAINMENT EVENTS IN THE FIELD OF RELIGION; PROVIDING FITNESS CLASSES FOR ADULT SENIORS; PROVIDING FITNESS AND EXERCISE FACILITIES IN THE NATURE OF A FITNESS CENTER FOR SENIOR ADULTS (U.S. CLS. 100, 101 AND 107).

CLASS 43—HOTEL AND RESTAURANT SERVICES

FOR RETIREMENT COMMUNITY FOR SENIOR ADULTS IN THE NATURE OF A RETIREMENT HOME; PROVIDING ELDER CARE IN THE NATURE OF DAY CARE CENTERS FOR SENIOR ADULTS (U.S. CLS. 100 AND 101).

CLASS 44—MEDICAL, BEAUTY AND AGRICULTURAL SERVICES

FOR CONTINUING CARE RETIREMENT COMMUNITY PROVIDING NURSING CARE FOR SENIOR ADULTS IN THE NATURE OF A NURSING HOME; PROVIDING HOME HEALTH CARE AND HOME-VISIT NURSING CARE SERVICES; PROVIDING HEALTH CARE SERVICES IN THE NATURE OF WELLNESS PROGRAMS AT A WELLNESS CENTER FOR SENIOR ADULTS; PROVIDING OUTPATIENT PHYSICAL REHABILITATION AND PHYSICAL, OCCUPATIONAL AND SPEECH THERAPY SERVICES (U.S. CLS. 100 AND 101).

CLASS 45—PERSONAL AND LEGAL SERVICES

FOR PROVIDING PERSONAL CARE ASSISTANCE WITH ACTIVITIES OF DAILY LIVING, SUCH AS BATHING, GROOMING AND PERSONAL MOBILITY, ALL FOR SENIOR ADULTS IN A RETIREMENT COMMUNITY; PROVIDING HOME CARE IN THE NATURE OF IN-HOME SUPPORT SERVICES TO SENIOR PERSONS, NAMELY, GERIATRIC CARE MANAGEMENT SERVICES IN THE NATURE OF THE COORDINATION OF NECESSARY SERVICES AND PERSONAL CARE FOR OLDER INDIVIDUALS (U.S. CLS. 100 AND 101).

NELSON SNYDER, EXAMINING ATTORNEY

SN 85-243,795. PSPROUTS, LLC, LOS ALTOS, CA. FILED 2-16-2011.



NO CLAIM IS MADE TO THE EXCLUSIVE RIGHT TO USE "COLLECTION", APART FROM THE MARK AS SHOWN.

THE STIPPLING IS A FEATURE OF THE MARK AND DOES NOT INDICATE COLOR.

THE MARK CONSISTS OF AN UPPER BORDER CONSISTING OF AN OVAL LABEL CONTAINING THE WORDS "THE BABYMIO COLLECTION" SUPERIMPOSED OVER A FIELD OF VERTICAL STRIPES, BENEATH WHICH A TIGER, COW, GIRAFFE, MOOSE, AND CHEETAH SIT OR STAND IN FRONT OF TWO TREES, FROM ONE OF WHICH A MONKEY HANGS BY ONE HAND, AND A FOREGROUND CONSISTING OF GRASSES AND OTHER PLANTS.

THE ENGLISH TRANSLATION OF "MIO" IN THE MARK IS "MY". THE WORDING "BABYMIO" HAS NO MEANING IN A FOREIGN LANGUAGE.

CLASS 24—FABRICS

FOR BABY BLANKETS; CHILDREN'S BLANKETS; LAP BLANKETS; RECEIVING BLANKETS (U.S. CLS. 42 AND 50).

FIRST USE 11-1-2010; IN COMMERCE 11-1-2010.

CLASS 28—TOYS AND SPORTING GOODS

FOR PLUSH TOYS; STUFFED AND PLUSH TOYS; STUFFED TOY ANIMALS (U.S. CLS. 22, 23, 38 AND 50).

FIRST USE 1-1-2011; IN COMMERCE 1-1-2011.

MARC LEIPZIG, EXAMINING ATTORNEY

SN 85-243,812. PSPROUTS, LLC, LOS ALTOS, CA. FILED 2-16-2011.

THE BABYMIO COLLECTION

THE MARK CONSISTS OF STANDARD CHARACTERS WITHOUT CLAIM TO ANY PARTICULAR FONT, STYLE, SIZE, OR COLOR.

NO CLAIM IS MADE TO THE EXCLUSIVE RIGHT TO USE "COLLECTION", APART FROM THE MARK AS SHOWN.

THE ENGLISH TRANSLATION OF "MIO" IN THE MARK IS "MY". THE WORDING "BABYMIO" HAS NO MEANING IN A FOREIGN LANGUAGE.

CLASS 24—FABRICS

FOR BABY BLANKETS; CHILDREN'S BLANKETS; LAP BLANKETS; RECEIVING BLANKETS (U.S. CLS. 42 AND 50).

FIRST USE 11-1-2010; IN COMMERCE 11-1-2010.

CLASS 28—TOYS AND SPORTING GOODS

FOR PLUSH TOYS; STUFFED AND PLUSH TOYS; STUFFED TOY ANIMALS (U.S. CLS. 22, 23, 38 AND 50).

FIRST USE 1-1-2011; IN COMMERCE 1-1-2011.

MARC LEIPZIG, EXAMINING ATTORNEY

SN 85-244,333. MICHAEL HESS INC, DBA HESS BREWING CO., SAN DIEGO, CA. FILED 2-16-2011.

Great Beer. No Exceptions. No Excuses.

THE MARK CONSISTS OF STANDARD CHARACTERS WITHOUT CLAIM TO ANY PARTICULAR FONT, STYLE, SIZE, OR COLOR.

NO CLAIM IS MADE TO THE EXCLUSIVE RIGHT TO USE "GREAT BEER" FOR INTERNATIONAL CLASS 32, APART FROM THE MARK AS SHOWN.

CLASS 21—HOUSEWARES AND GLASS

FOR DRINKING GLASSES (U.S. CLS. 2, 13, 23, 29, 30, 33, 40 AND 50).

FIRST USE 10-4-2009; IN COMMERCE 7-7-2010.

CLASS 25—CLOTHING

FOR SHIRTS (U.S. CLS. 22 AND 39).

FIRST USE 10-4-2009; IN COMMERCE 7-7-2010.

CLASS 32—LIGHT BEVERAGES

FOR BEER (U.S. CLS. 45, 46 AND 48).

FIRST USE 10-4-2009; IN COMMERCE 7-7-2010.

JENNY PARK, EXAMINING ATTORNEY

SN 85-244,826. NORA CONSTANCE MARINO, GREAT NECK, NY. FILED 2-17-2011.

VEGAN COUGAR

THE MARK CONSISTS OF STANDARD CHARACTERS WITHOUT CLAIM TO ANY PARTICULAR FONT, STYLE, SIZE, OR COLOR.

NO CLAIM IS MADE TO THE EXCLUSIVE RIGHT TO USE "VEGAN", APART FROM THE MARK AS SHOWN.

CLASS 3—COSMETICS AND CLEANING PREPARATIONS

FOR BODY AND BEAUTY CARE COSMETICS; BATH AND SHOWER PRODUCTS, NAMELY, BATH GELS, BATH OILS, BODY WASH, BODY SCRUBS, BODY SKIN MOISTURIZERS, BODY BUTTER, BUBBLE BATH, CONDITIONERS, SHAMPOO, SHOWER GELS, SOAPS; BODY AND FOOT CARE PRODUCTS, NAMELY, COSMETIC PREPARATIONS FOR BODY CARE AND NON-MEDICATED FOOT CREAM; COLOGNES, PERFUMES AND FRAGRANCES; COLORING PREPARATIONS FOR COSMETIC PURPOSES; CONCEALERS; COSMETIC CREAMS FOR SKIN CARE; COSMETIC HAIR DRESSING PREPARATIONS; COSMETIC PENCILS; COSMETIC PREPARATIONS; COSMETIC PREPARATIONS FOR EYE LASHES; COSMETIC PREPARATIONS FOR SKIN RENEWAL; COSMETIC PREPARATIONS FOR SLIMMING PURPOSES; COSMETIC PREPARATIONS FOR THE CARE OF MOUTH AND TEETH; COSMETIC PREPARATIONS FOR THE HAIR AND SCALP; COSMETIC PREPARATIONS, NAMELY, FIRMING CREAMS; COSMETIC PREPARATIONS, NAMELY, FIRMING LOTIONS AND MOISTURIZING SERUMS; COSMETIC PREPARATIONS, NAMELY, SKIN BALSAMS; COSMETIC ROUGES; COSMETIC SOAPS; COSMETIC SUN-PROTECTING PREPARATIONS; COSMETIC SUNTAN LOTIONS; COSMETICS AND MAKE-UP; COSMETICS IN THE FORM OF LOTIONS AND EMULSIONS; COSMETICS, NAMELY, COMPACTS; COSMETICS, NAMELY, LIP PRIMER; COSMETICS, NAMELY, LIP REPAIRERS; COTTON PUFFS FOR COSMETIC PURPOSES; COTTON SWABS FOR COSMETIC PURPOSES; DEODORANTS FOR PERSONAL USE; EYE COMPRESSES FOR COSMETIC PURPOSES; EYEBROW COSMETICS; FACE CREAMS AND CLEANSERS FOR CLEANSING PURPOSES, MOISTURIZING PURPOSES AND COSMETIC USE; FOAMS CONTAINING COSMETICS AND SUNSCREENS; GIFT BASKETS CONTAINING NON-MEDICATED BATH PREPARATIONS AND COSMETIC PREPARATIONS; HAIR COLOR AND HAIR DYE; NAIL POLISH, NAIL POLISH REMOVER; NAIL VARNISH FOR COSMETIC PURPOSES; PARAFIN WAX FOR COSMETIC PURPOSES; PERFUME OILS FOR THE MANUFACTURE OF COSMETIC PREPARATIONS; PLANT AND HERB EXTRACTS SOLD AS COMPONENTS OF COSMETICS; PRE-MOISTENED COSMETIC TISSUES; PRE-MOISTENED COSMETIC TOWELTETS; PRE-MOISTENED COSMETIC WIPES; RETINOL CREAM FOR COSMETIC PURPOSES; SKIN AND BODY TOPICAL LOTIONS, CREAMS AND OILS FOR COSMETIC USE; SKIN CONDITIONING CREAMS FOR COSMETIC PURPOSES; SOAPS; SOLID POWDER FOR COMPACTS; TANNING GELS; TANNING OILS; TEETH WHITENING STRIPS IMPREGNATED WITH TEETH WHITENING PREPARATIONS; TISSUES IMPREGNATED WITH COSMETIC LOTIONS; TONERS; TOPICAL SKIN SPRAYS FOR COSMETIC PURPOSES; WRINKLE-MINIMIZING COSMETIC PREPARATIONS FOR TOPICAL FACIAL USE, ALL OF THE FOREGOING GOODS MADE WITHOUT ANIMAL PRODUCTS (U.S. CLS. 1, 4, 6, 50, 51 AND 52).

CLASS 25—CLOTHING

FOR CLOTHING FOR WOMEN, MEN AND CHILDREN, NAMELY, SHIRTS, T-SHIRTS, SWEATSHIRTS, BLOUSES, PULLOVERS, TANK TOPS, JACKETS, COATS, SWEATERS, VESTS, PANTS, SWEATPANTS, SHORTS, BOTTOMS, SKIRTS, AND DRESSES; FASHION ACCESSORIES, NAMELY, HATS, CAPS, VISORS, HEADBANDS, WRISTBANDS, HOODS, SCARVES, BANDANAS, NECKTIES, MUFFLERS, GLOVES, MITTENS AND BELTS; UNDERWEAR, NAMELY, BOXER SHORTS, UNDERSHORTS, UNDERPANTS, BRAS, SOCKS, AND HOSIERY; SWIM WEAR, BEACHWEAR, AND LOUNGEWEAR, NAMELY, PAJAMAS AND ROBES, ALL OF THE FOREGOING GOODS MADE WITHOUT ANIMAL PRODUCTS (U.S. CLS. 22 AND 39).

CLASS 41—EDUCATION AND ENTERTAINMENT

FOR ENTERTAINMENT SERVICES, NAMELY, LIVE PERFORMANCES AND PERSONAL APPEARANCES BY A REALITY SHOW AND TALK SHOW PERSONALITY; ENTERTAINMENT SERVICES, NAMELY, LIVE, TELEVISED AND MOVIE APPEARANCES BY A PROFESSIONAL ENTERTAINER; ENTERTAINMENT SERVICES, NAMELY, PERSONAL APPEARANCES BY A MEDIA CELEBRITY, MODEL AND ACTRESS; EDUCATIONAL AND ENTERTAINMENT SERVICES, NAMELY, PROVIDING MOTIVATIONAL SPEAKING SERVICES IN THE FIELD OF VEGANISM (U.S. CLS. 100, 101 AND 107).

CLASS 43—HOTEL AND RESTAURANT SERVICES

FOR PROVIDING INFORMATION ABOUT VEGAN COOKING (U.S. CLS. 100 AND 101).

CLASS 44—MEDICAL, BEAUTY AND AGRICULTURAL SERVICES

FOR PROVIDING INFORMATION ABOUT VEGAN DIETS, DIET PLANNING AND LIFESTYLE WELLNESS (U.S. CLS. 100 AND 101).

NELSON SNYDER, EXAMINING ATTORNEY

SN 85-245,556. OLIVE INTERNATIONAL LIMITED, APIA, SAMOA, FILED 2-17-2011.



THE MARK CONSISTS OF FOUR CURVED LINES FORMING THE TOP HALF OF A CONCENTRIC-CIRCLE DESIGN. BELOW THE PARTIAL CONCENTRIC-CIRCLE DESIGN IS THE TERM "OORANA" IN STYLIZED FORM. A STRING OF DOTS APPEAR BETWEEN THE OUTERMOST CURVED LINE AND THE CURVED LINE BELOW IT. ANOTHER STRING OF DOTS IN SMALLER SIZE APPEAR BETWEEN THE SECOND OUTERMOST CURVED LINE AND THE CURVED LINE BELOW IT.

CLASS 18—LEATHER GOODS

FOR HANDBAGS; ANIMAL SKINS AND HIDES (U.S. CLS. 1, 2, 3, 22 AND 41).
FIRST USE 1-1-2010; IN COMMERCE 1-1-2010.

CLASS 25—CLOTHING

FOR FOOTWEAR (U.S. CLS. 22 AND 39).
FIRST USE 1-1-2010; IN COMMERCE 1-1-2010.
MICHAEL TANNER, EXAMINING ATTORNEY

SN 85-246,178. ONE TO WON LIMITED, LONDON, UNITED KINGDOM, FILED 2-18-2011.

SN 85-247,530. QUORUM GROUP, LLC, DBA TAKEFORM ARCHITECTURAL GRAPHICS, MEDINA, NY. FILED 2-21-2011.

ONE TO WON

THE MARK CONSISTS OF STANDARD CHARACTERS WITHOUT CLAIM TO ANY PARTICULAR FONT, STYLE, SIZE, OR COLOR.

CLASS 9—ELECTRICAL AND SCIENTIFIC APPARATUS

FOR DOWNLOADABLE ELECTRONIC PUBLICATIONS AND ELECTRONIC PUBLICATIONS RECORDED ON ELECTRONIC MEDIA IN THE NATURE OF A SERIES OF BULLETINS AND NEWSLETTERS IN THE FIELDS OF SOCIAL INTERACTION, NETWORKING AND CHANGE RELATING TO HEALTHCARE, ECONOMICS, CHILD REARING, EDUCATION, AS WELL AS OTHER TOPICS OF GENERAL INTEREST AND INCLUDING THOSE RELATING TO THE FIELD OF CONSULTING SERVICES FOR NON-PROFIT ORGANIZATIONS (U.S. CLS. 21, 23, 26, 36 AND 38).

CLASS 16—PAPER GOODS AND PRINTED MATTER

FOR PRINTED PUBLICATIONS IN THE NATURE OF A SERIES OF BOOKS, BULLETINS AND NEWSLETTERS IN THE FIELDS OF SOCIAL INTERACTION, NETWORKING AND CHANGE RELATING TO HEALTHCARE, ECONOMICS, CHILD REARING, EDUCATION, AS WELL AS OTHER TOPICS OF GENERAL INTEREST AND INCLUDING THOSE RELATING TO THE FIELD OF CONSULTING SERVICES FOR NON-PROFIT ORGANIZATIONS (U.S. CLS. 2, 5, 22, 23, 29, 37, 38 AND 50).

CLASS 35—ADVERTISING AND BUSINESS

FOR BUSINESS CONSULTATION SERVICES PROVIDED TO ORGANIZATIONS IN THE FIELDS OF SOCIAL INTERACTION, NETWORKING AND CHANGE RELATING TO HEALTHCARE, ECONOMICS, CHILD REARING, AND EDUCATION AS WELL AS OTHER TOPICS (U.S. CLS. 100, 101 AND 102).

CLASS 36—INSURANCE AND FINANCIAL

FOR PROVIDING GRANTS TO INDIVIDUALS TO FUND PROJECTS TO HELP OTHERS (U.S. CLS. 100, 101 AND 102).

CLASS 42—SCIENTIFIC AND COMPUTER SERVICES

FOR COMPUTER SERVICES, NAMELY, CREATING AN ON-LINE COMMUNITY FOR REGISTERED USERS TO PARTICIPATE IN DISCUSSIONS, GET FEEDBACK FROM THEIR PEERS, FORM VIRTUAL COMMUNITIES, AND ENGAGE IN SOCIAL NETWORKING FEATURING SOCIAL MEDIA AND TOPICS ON SOCIAL CHANGE RELATING TO HEALTHCARE, ECONOMICS, CHILD REARING, EDUCATION, AND OTHER TOPICS OF GENERAL INTEREST AND INCLUDING THOSE RELATING TO THE FIELD OF CONSULTING SERVICES FOR NON-PROFIT ORGANIZATIONS (U.S. CLS. 100 AND 101).

CHRIS WELLS, EXAMINING ATTORNEY

takeform

THE MARK CONSISTS OF STANDARD CHARACTERS WITHOUT CLAIM TO ANY PARTICULAR FONT, STYLE, SIZE, OR COLOR.

CLASS 19—NON-METALLIC BUILDING MATERIALS

FOR INTERIOR AND EXTERIOR ARCHITECTURAL SIGNAGE FOR RESIDENTIAL, CORPORATE, HOSPITALITY, HEALTH CARE, AND INSTITUTIONAL ENVIRONMENTS, NAMELY, NON-LUMINOUS, NON-MECHANICAL SIGNS NOT OF METAL FOR USE AS BUILDING AND ROOM IDENTIFICATIONS, DIRECTIONAL SIGNAGE, DIRECTORIES, AND FIRE AND EVACUATION SIGNAGE (U.S. CLS. 1, 12, 33 AND 50).

FIRST USE 8-31-2003; IN COMMERCE 8-31-2003.

CLASS 42—SCIENTIFIC AND COMPUTER SERVICES

FOR DESIGNING INTERIOR AND EXTERIOR ARCHITECTURAL SIGNAGE FOR RESIDENTIAL, CORPORATE, HOSPITALITY, HEALTH CARE, AND INSTITUTIONAL ENVIRONMENTS, NAMELY, DESIGNING AND GRAPHIC ARTS DESIGNING OF NON-LUMINOUS, NON-MECHANICAL SIGNS NOT OF METAL FOR USE AS BUILDING AND ROOM IDENTIFICATIONS, DIRECTIONAL SIGNAGE, DIRECTORIES, AND FIRE AND EVACUATION SIGNAGE (U.S. CLS. 100 AND 101).

FIRST USE 8-31-2003; IN COMMERCE 8-31-2003.

BERYL GARDNER, EXAMINING ATTORNEY

SN 85-249,147. VITAS HOSPICE SERVICES, L.L.C., MIAMI, FL. FILED 2-23-2011.

TIKVAH HOSPICE

THE MARK CONSISTS OF STANDARD CHARACTERS WITHOUT CLAIM TO ANY PARTICULAR FONT, STYLE, SIZE, OR COLOR.

NO CLAIM IS MADE TO THE EXCLUSIVE RIGHT TO USE "HOSPICE", APART FROM THE MARK AS SHOWN.

CLASS 44—MEDICAL, BEAUTY AND AGRICULTURAL SERVICES

FOR MEDICAL AND COUNSELING SERVICES FOR TERMINALLY ILL PATIENTS AND THEIR FAMILIES, SUCH AS PAIN AND SYMPTOM CONTROL AND PSYCHO-SOCIAL AND SPIRITUAL SUPPORT (U.S. CLS. 100 AND 101).

CLASS 45—PERSONAL AND LEGAL SERVICES

FOR BEREAVEMENT COUNSELING FOR FAMILIES OF DECEASED PATIENTS (U.S. CLS. 100 AND 101).

INGA ERVIN, EXAMINING ATTORNEY

SN 85-249,457. THE SUNRIDER CORPORATION, DBA SUNRIDER INTERNATIONAL, TORRANCE, CA. FILED 2-23-2011.

SUNLIVING

THE MARK CONSISTS OF STANDARD CHARACTERS WITHOUT CLAIM TO ANY PARTICULAR FONT, STYLE, SIZE, OR COLOR.

CLASS 11—ENVIRONMENTAL CONTROL APPARATUS

FOR AIR FILTERS, NAMELY, AIR FILTERS FOR DOMESTIC PURPOSES; AIR PURIFICATION UNITS; AIR CLEANSING UNITS; WATER FILTERING UNITS; WATER IONIZERS; WATER PURIFICATION UNITS; WATER TREATMENT EQUIPMENT, NAMELY, WATER FILTRATION UNITS (U.S. CLS. 13, 21, 23, 31 AND 34).

CLASS 32—LIGHT BEVERAGES

FOR MINERAL AND AERATED WATERS AND OTHER NONALCOHOLIC DRINKS, NAMELY, PUNCHES, CARBONATED BEVERAGES, SMOOTHIES, NON-ALCOHOLIC BEVERAGES WITH TEA FLAVOR, AND NON-ALCOHOLIC BEVERAGES WITH COFFEE FLAVOR; FRUIT DRINKS AND VEGETABLE JUICES; HERBAL JUICES; SYRUPS AND CONCENTRATES USED IN THE PREPARATION OF NON-ALCOHOLIC BEVERAGES WITH THE EXCEPTION OF EFFERVESCENT TABLETS FOR DRINKS, POWDERS AND INSTANT PREPARATIONS FOR MAKING BEVERAGES (U.S. CLS. 45, 46 AND 48).

ALLISON SCHRODY, EXAMINING ATTORNEY

SN 85-251,747. GENESIS CASKET COMPANY, LLC, TROY, MI. FILED 2-25-2011.

GENESIS

THE MARK CONSISTS OF STANDARD CHARACTERS WITHOUT CLAIM TO ANY PARTICULAR FONT, STYLE, SIZE, OR COLOR.

CLASS 6—METAL GOODS

FOR BURIAL VAULTS OF METAL; FREE-STANDING METAL PANEL UNITS FOR DISPLAYS ALONGSIDE FUNERARY CASKETS, URNS AND VAULTS (U.S. CLS. 2, 12, 13, 14, 23, 25 AND 50).

CLASS 19—NON-METALLIC BUILDING MATERIALS

FOR BURIAL VAULTS NOT OF METAL (U.S. CLS. 1, 12, 33 AND 50).

CLASS 20—FURNITURE AND ARTICLES NOT OTHERWISE CLASSIFIED

FOR CASKETS; FUNERARY URNS; DISPLAY HEAD PANELS FOR CASKETS FOR DISPLAYING PICTURES AND INFORMATION ABOUT DECEASED; AND FREE-STANDING NON-METAL PANEL UNITS FOR DISPLAYS ALONGSIDE FUNERARY CASKETS; URNS AND VAULTS (U.S. CLS. 2, 13, 22, 25, 32 AND 50).
ALEXANDER L. POWERS, EXAMINING ATTORNEY

SN 85-251,776. GENESIS CASKET COMPANY, LLC, TROY, MI. FILED 2-25-2011.

GENESIS CASKET COMPANY

THE MARK CONSISTS OF STANDARD CHARACTERS WITHOUT CLAIM TO ANY PARTICULAR FONT, STYLE, SIZE, OR COLOR.

NO CLAIM IS MADE TO THE EXCLUSIVE RIGHT TO USE "CASKET COMPANY", APART FROM THE MARK AS SHOWN.

CLASS 6—METAL GOODS

FOR BURIAL VAULTS OF METAL; FREE-STANDING METAL PANEL UNITS FOR DISPLAYS ALONGSIDE FUNERARY CASKETS, URNS AND VAULTS (U.S. CLS. 2, 12, 13, 14, 23, 25 AND 50).

CLASS 19—NON-METALLIC BUILDING MATERIALS

FOR BURIAL VAULTS NOT OF METAL (U.S. CLS. 1, 12, 33 AND 50).

CLASS 20—FURNITURE AND ARTICLES NOT OTHERWISE CLASSIFIED

FOR CASKETS; FUNERARY URNS; DISPLAY HEAD PANELS FOR CASKETS FOR DISPLAYING PICTURES AND INFORMATION ABOUT DECEASED; AND FREE-STANDING NON-METAL PANEL UNITS FOR DISPLAYS ALONGSIDE FUNERARY CASKETS, URNS AND VAULTS (U.S. CLS. 2, 13, 22, 25, 32 AND 50).
ALEXANDER L. POWERS, EXAMINING ATTORNEY

SN 85-252,943. SOCIAL OUTBREAK, CORP, LASVEGAS, NV. FILED 2-28-2011.

SOCIAL OUTBREAK

THE MARK CONSISTS OF STANDARD CHARACTERS WITHOUT CLAIM TO ANY PARTICULAR FONT, STYLE, SIZE, OR COLOR.

NO CLAIM IS MADE TO THE EXCLUSIVE RIGHT TO USE "SOCIAL", APART FROM THE MARK AS SHOWN.

CLASS 35—ADVERTISING AND BUSINESS

FOR ADVERTISING AND MARKETING SERVICES PROVIDED BY MEANS OF INDIRECT METHODS OF MARKETING COMMUNICATIONS, NAMELY, SOCIAL MEDIA, SEARCH ENGINE MARKETING, AND INTERNET MARKETING (U.S. CLS. 100, 101 AND 102).

CLASS 42—SCIENTIFIC AND COMPUTER SERVICES

FOR COMPUTER SERVICES, NAMELY, DESIGNING AND IMPLEMENTING WEB SITES FOR OTHERS; DESIGN OF HOME PAGES, COMPUTER SOFTWARE AND WEB SITES (U.S. CLS. 100 AND 101).

PATRICIA EVANKO, EXAMINING ATTORNEY

SN 85-253,489. DOWN RIGHT LTD., BROOKLYN, NY. FILED 2-28-2011.



OWNER OF U.S. REG. NOS. 1,854,679 AND 3,153,988. NO CLAIM IS MADE TO THE EXCLUSIVE RIGHT TO USE "ESTABLISHED 1975", APART FROM THE MARK AS SHOWN.

THE MARK CONSISTS OF A DESIGN PORTION OF LEAVES WITH THE WORD "DOWNRIGHT" BELOW THE DESIGN AND THE WORDING "ESTABLISHED 1975" BELOW THE WORD "DOWNRIGHT".

CLASS 20—FURNITURE AND ARTICLES NOT OTHERWISE CLASSIFIED

FOR DOWN PILLOWS (U.S. CLS. 2, 13, 22, 25, 32 AND 50).

FIRST USE 2-23-2011; IN COMMERCE 2-23-2011.

CLASS 24—FABRICS

FOR DOWN BED BLANKETS; DOWN COMFORTERS; DOWN QUILTS (U.S. CLS. 42 AND 50).

FIRST USE 2-23-2011; IN COMMERCE 2-23-2011.

LINDA M. KING, EXAMINING ATTORNEY

SN 85-254,207. RETAIL ROYALTY COMPANY, LAS VEGAS, NV. FILED 3-1-2011.

quick♥fixes

OWNER OF U.S. REG. NO. 3,703,194. THE MARK CONSISTS OF THE WORDS "QUICK FIXES" WITH A HEART SYMBOL BETWEEN THE WORDS.

CLASS 25—CLOTHING

FOR LINGERIE ACCESSORIES, NAMELY, REMOVABLE BREAST ENHANCER PADS USED IN A BRA; SELF-ADHESIVE NIPPLE COVERS FOR BREASTS; SELF-ADHESIVE BRA CUPS (U.S. CLS. 22 AND 39).

CLASS 26—FANCY GOODS

FOR BODY AND CLOTHING TAPE, NAMELY, ADHESIVE TAPE TO KEEP CLOTHING IN PLACE; BRA STRAP POSITIONING DEVICE, NAMELY, BRA STRAP POSITIONING CLIP (U.S. CLS. 37, 39, 40, 42 AND 50).

FONG HSU, EXAMINING ATTORNEY

SN 85-254,252. WILDLIFE IN CRISIS, INC., WESTON, CT. FILED 3-1-2011.

THE WILDLIFE CARE CENTER

THE MARK CONSISTS OF STANDARD CHARACTERS WITHOUT CLAIM TO ANY PARTICULAR FONT, STYLE, SIZE, OR COLOR.

SEC. 2(F).

CLASS 36—INSURANCE AND FINANCIAL

FOR CHARITABLE SERVICES, NAMELY, RAISING MONEY FOR WILDLIFE PRESERVATION AND LAND CONSERVATION (U.S. CLS. 100, 101 AND 102).

FIRST USE 11-8-1989; IN COMMERCE 11-8-1989.

CLASS 44—MEDICAL, BEAUTY AND AGRICULTURAL SERVICES

FOR WILDLIFE PRESERVATION, NAMELY, VETERINARY SERVICES AND REHABILITATION PATIENT CARE SERVICES FOR WILD ANIMALS (U.S. CLS. 100 AND 101).

FIRST USE 11-8-1989; IN COMMERCE 11-8-1989.

KATHY DE JONGE, EXAMINING ATTORNEY

SN 85-254,449. FABASOFT AG, LINZ, AUSTRIA, FILED 3-1-2011.

WATTMAP

THE MARK CONSISTS OF STANDARD CHARACTERS WITHOUT CLAIM TO ANY PARTICULAR FONT, STYLE, SIZE, OR COLOR.

OWNER OF ERPN CMNTY TM OFC REG. NO. 009216052, DATED 1-20-2011, EXPIRES 1-20-2021.

CLASS 9—ELECTRICAL AND SCIENTIFIC APPARATUS

FOR DATA PROCESSORS; BLANK MAGNETIC DATA CARRIERS; COMPACT DISCS FEATURING DATA PROCESSOR FUNCTIONS; COMPUTER OPERATING PROGRAMS; COMPUTERS; COMPUTER HARDWARE (U.S. CLS. 21, 23, 26, 36 AND 38).

CLASS 35—ADVERTISING AND BUSINESS

FOR BUSINESS ORGANIZATION CONSULTANCY IN THE FIELD OF ELECTRONIC DATA PROCESSING (U.S. CLS. 100, 101 AND 102).

CLASS 37—CONSTRUCTION AND REPAIR

FOR MAINTENANCE AND REPAIR OF DATA PROCESSING EQUIPMENT AND COMPUTERS (U.S. CLS. 100, 103 AND 106).

CLASS 41—EDUCATION AND ENTERTAINMENT

FOR TRAINING SERVICES, INSTRUCTION AND CONDUCTING SEMINARS IN THE FIELD OF ELECTRONICALLY ASSISTED DATA PROCESSING (U.S. CLS. 100, 101 AND 107).

CLASS 42—SCIENTIFIC AND COMPUTER SERVICES

FOR TECHNICAL CONSULTANCY IN THE FIELD OF INFORMATION TECHNOLOGY AND COMPUTER SOFTWARE (U.S. CLS. 100 AND 101).

IRA J. GOODSAD, EXAMINING ATTORNEY

CLASS 37—CONSTRUCTION AND REPAIR

FOR REPAIR AND MAINTENANCE OF GAS AND ELECTRICAL APPLIANCES, NAMELY, AIR CONDITIONERS, HEATERS, DISHWASHERS, REFRIGERATORS, JETTED BATHS AND SPAS, MICROWAVE OVENS, BARBECUES, WINE COOLERS, VENT HOODS, GARBAGE DISPOSALS, TRASH COMPACTORS, GAS AND ELECTRIC RANGES, WASHING MACHINES AND DRYING MACHINES FOR CLOTHES FOR HOUSEHOLD PURPOSES AND FIREPLACES; RENTAL OF GAS AND ELECTRICAL CLEANING EQUIPMENT, NAMELY, DISHWASHERS; RENTAL OF GAS AND ELECTRICAL LAUNDRY APPLIANCES, NAMELY, RENTAL OF WASHING MACHINES AND DRYING MACHINES FOR CLOTHES FOR HOUSEHOLD PURPOSES; RENTAL OF LAUNDRY EQUIPMENT, NAMELY, LAUNDRY CARTS, HAMPERS, RACKS, BASKETS AND SHELVING FOR THE LAUNDRY, HEALTHCARE, MEDICAL, HOSPITALITY AND ENTERTAINMENT INDUSTRIES (U.S. CLS. 100, 103 AND 106).

FIRST USE 0-0-1955; IN COMMERCE 6-22-2005.

KALIE KUNG, EXAMINING ATTORNEY

SN 85-255,089. BARDEN, MICHAEL, SAN FRANCISCO, CA. FILED 3-1-2011.

SN 85-254,625. ANGEL TV & APPLIANCE SERVICE, NORTH HILLS, CA. FILED 3-1-2011.

ANGEL APPLIANCES

Spank You Notes

THE MARK CONSISTS OF STANDARD CHARACTERS WITHOUT CLAIM TO ANY PARTICULAR FONT, STYLE, SIZE, OR COLOR.

NO CLAIM IS MADE TO THE EXCLUSIVE RIGHT TO USE "APPLIANCES", APART FROM THE MARK AS SHOWN.

CLASS 35—ADVERTISING AND BUSINESS

FOR RETAIL STORE SERVICES FEATURING GAS AND ELECTRICAL APPLIANCES, NAMELY, AIR CONDITIONERS, HEATERS, DISHWASHERS, REFRIGERATORS, JETTED BATHS AND SPAS, MICROWAVE OVENS, BARBECUES, WINE COOLERS, VENT HOODS, GARBAGE DISPOSALS, TRASH COMPACTORS, GAS AND ELECTRIC RANGES, WASHING MACHINES AND DRYING MACHINES FOR CLOTHES FOR HOUSEHOLD PURPOSES, FIREPLACES, AND PARTS AND SUPPLIES FOR SUCH GOODS; RETAIL STORE SERVICES FEATURING LAUNDRY CARTS, HAMPERS, RACKS, BASKETS AND SHELVING FOR THE LAUNDRY, HEALTHCARE, MEDICAL, HOSPITALITY AND ENTERTAINMENT INDUSTRIES (U.S. CLS. 100, 101 AND 102).

FIRST USE 0-0-1955; IN COMMERCE 6-22-2005.

THE MARK CONSISTS OF STANDARD CHARACTERS WITHOUT CLAIM TO ANY PARTICULAR FONT, STYLE, SIZE, OR COLOR.

NO CLAIM IS MADE TO THE EXCLUSIVE RIGHT TO USE "NOTES", APART FROM THE MARK AS SHOWN.

CLASS 38—COMMUNICATION

FOR DELIVERY OF PERSONALIZED GREETING CARDS TO OTHERS VIA ELECTRONIC MAIL (U.S. CLS. 100, 101 AND 104).

CLASS 45—PERSONAL AND LEGAL SERVICES

FOR PROVIDING A SELECTION OF ON-LINE ELECTRONIC GREETING CARDS (U.S. CLS. 100 AND 101).

MICHAEL TANNER, EXAMINING ATTORNEY

SN 85-256,796. KOEN KLINGELE, GENT-MARIAKERKE, BELGIUM, FILED 3-3-2011.

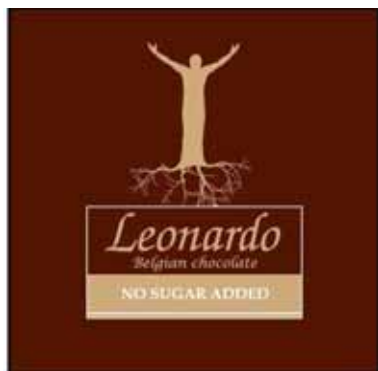

NO CLAIM IS MADE TO THE EXCLUSIVE RIGHT TO USE "BELGIAN CHOCOLATE" OR "NO SUGAR ADDED", APART FROM THE MARK AS SHOWN.

THE COLOR(S) BROWN, GOLD AND WHITE IS/ARE CLAIMED AS A FEATURE OF THE MARK.

THE MARK CONSISTS OF THE WORDS "LEONARDO BELGIAN CHOCOLATE NO SUGAR ADDED" WITHIN A RECTANGULAR BOX WHICH IS OUTLINED IN WHITE. THE UPPER TWO-THIRDS OF THE BOX HAS A BROWN BACKGROUND AND THE LOWER THIRD HAS A GOLD BACKGROUND. THE WORD "LEONARDO" IS SET FORTH IN LARGE GOLD LETTERS IN THE UPPER PORTION OF THE BOX AND THE WORDS "BELGIAN CHOCOLATE" ARE SET FORTH IN SMALLER GOLD LETTERS BENEATH IT. THE WORDS "NO SUGAR ADDED" ARE SET FORTH IN WHITE LETTERS IN THE LOWER THIRD OF THE BOX. ABOVE THE RECTANGULAR BOX IS A FANCIFUL DESIGN IN GOLD COMPRISING THE UPPER BODY OF A MAN WITH HIS ARMS OUTSTRETCHED; THE LOWER PORTION OF WHICH IS THE TRUNK OF A TREE WITH ITS ROOTS SHOWING AT THE BOTTOM. THE ENTIRE FOREGOING DESIGN IS SET FORTH WITHIN A BROWN SQUARE BACKGROUND.

CLASS 29—MEATS AND PROCESSED FOODS

FOR SUGAR FREE JELLIES AND JAMS; SUGAR FREE BELGIAN CHOCOLATE NUT BUTTER (U.S. CL. 46).

CLASS 30—STAPLE FOODS

FOR SUGAR FREE CHOCOLATES, NAMELY, BELGIAN CHOCOLATE BARS, BELGIAN CHOCOLATE CONFECTIONS, BELGIAN CHOCOLATE PRALINES, BELGIAN CHOCOLATE CANDIES; BELGIAN CHOCOLATE TRUFFLES; BELGIAN CHOCOLATE PASTES; COOKIES CONTAINING BELGIAN CHOCOLATE; WAFFLES CONTAINING BELGIAN CHOCOLATE (U.S. CL. 46).

MATTHEW EINSTEIN, EXAMINING ATTORNEY

SN 85-257,488. JOHANN SITTER, FRIENDSWOOD, TX, FILED 3-3-2011.

Bratwurst King

THE MARK CONSISTS OF STANDARD CHARACTERS WITHOUT CLAIM TO ANY PARTICULAR FONT, STYLE, SIZE, OR COLOR.

NO CLAIM IS MADE TO THE EXCLUSIVE RIGHT TO USE "BRATWURST", APART FROM THE MARK AS SHOWN.

CLASS 30—STAPLE FOODS

FOR SANDWICHES, NAMELY, SAUSAGE (U.S. CL. 46).

CLASS 43—HOTEL AND RESTAURANT SERVICES

FOR RESTAURANT SERVICES FEATURING SANDWICHES (U.S. CLS. 100 AND 101).
WANDA KAY PRICE, EXAMINING ATTORNEY

SN 85-257,853. CPS PRODUCTS, INC., HIALEAH, FL. FILED S.R. 3-4-2011; AM. P.R. 6-15-2011.

BLACKMAX

THE MARK CONSISTS OF STANDARD CHARACTERS WITHOUT CLAIM TO ANY PARTICULAR FONT, STYLE, SIZE, OR COLOR.

CLASS 9—ELECTRICAL AND SCIENTIFIC APPARATUS

FOR PRESSURE AND TEMPERATURE GAUGES, AND REFRIGERANT SCALES, FOR USE WITH AIR CONDITIONING AND REFRIGERATION SYSTEMS (U.S. CLS. 21, 23, 26, 36 AND 38).

FIRST USE 5-15-2002; IN COMMERCE 5-15-2002.

CLASS 11—ENVIRONMENTAL CONTROL APPARATUS

FOR PARTS FOR AIR CONDITIONING AND REFRIGERATION SYSTEMS, NAMELY, MANIFOLDS AND VALVES (U.S. CLS. 13, 21, 23, 31 AND 34).

FIRST USE 5-15-2002; IN COMMERCE 5-15-2002.

MARIA-VICTORIA SUAREZ, EXAMINING ATTORNEY

SN 85-258,008. RAYMOND LONG, DBA BANDHA YOGA, BALDWINVILLE, NY. FILED 3-4-2011.

MAT COMPANION

THE MARK CONSISTS OF STANDARD CHARACTERS WITHOUT CLAIM TO ANY PARTICULAR FONT, STYLE, SIZE, OR COLOR.

NO CLAIM IS MADE TO THE EXCLUSIVE RIGHT TO USE "MAT", APART FROM THE MARK AS SHOWN.

CLASS 18—LEATHER GOODS

FOR ALL PURPOSE SPORT BAGS; ATHLETIC BAGS; GYM BAGS; SPORT BAGS (U.S. CLS. 1, 2, 3, 22 AND 41).

CLASS 25—CLOTHING

FOR YOGA PANTS; YOGA SHIRTS (U.S. CLS. 22 AND 39).

CLASS 28—TOYS AND SPORTING GOODS

FOR YOGA ACCESSORIES, NAMELY, YOGA MAT CARRYING APPARATUS COMPRISING A CENTRAL WINDING CORE AFFIXED TO REMOVABLE END CAPS; YOGA BLOCKS; YOGA MATS; YOGA STRAPS (U.S. CLS. 22, 23, 38 AND 50).

HEATHER SAPP, EXAMINING ATTORNEY

SN 85-258,162. TRACTOR SUPPLY CO. OF TEXAS, LP, BRENTWOOD, TN. FILED 3-4-2011.

COUNTYLINE

THE MARK CONSISTS OF STANDARD CHARACTERS WITHOUT CLAIM TO ANY PARTICULAR FONT, STYLE, SIZE, OR COLOR.

OWNER OF U.S. REG. NOS. 3,475,488 AND 3,806,658.

CLASS 7—MACHINERY

FOR THREE POINT SNOW BLADES; MACHINE PARTS FOR FARM AND AGRICULTURAL EQUIPMENT, NAMELY, PULLEYS, CHAIN SPROCKETS, HUBS FOR SPROCKET AND PULLEY ASSEMBLIES, BEARINGS, BALER TEETH, BELTS, ROUND BALER BELTS, BEARINGS AND SEALS, CLUTCHES, CUTTING SECTIONS FOR HAY MOWING EQUIPMENT, DISK MOWER BLADES, DRIVELINES, FEEDER PLUNGER BEARINGS, FILTERS, KNIVES, BELT LACERS, BELT LACING AND BELT PINS, MOISTURE TESTERS FOR HAY, FORAGE AND GRAIN, ENGINE MUFFLERS, HAY RAKE TEETH, ROCK GUARDS, ROLLER CHAINS, SKID PLATES, WEAR PLATES, AND WINDROWER TEETH; SEATS FOR BACKHOES, SKID LOADERS AND RIDING LAWN MOWERS (U.S. CLS. 13, 19, 21, 23, 31, 34 AND 35).

CLASS 12—VEHICLES

FOR SEATS FOR TRACTORS, LAWN AND GARDEN TRACTORS AND FORK LIFT TRUCKS (U.S. CLS. 19, 21, 23, 31, 35 AND 44).

KATHLEEN LORENZO, EXAMINING ATTORNEY

SN 85-258,653. AVIATION, POWER & MARINE, INC., BOYNTON BEACH, FL. FILED 3-4-2011.

AP&M

THE MARK CONSISTS OF STANDARD CHARACTERS WITHOUT CLAIM TO ANY PARTICULAR FONT, STYLE, SIZE, OR COLOR.

CLASS 35—ADVERTISING AND BUSINESS

FOR RETAIL STORE SERVICES IN THE FIELD OF AIRCRAFT, INDUSTRIAL AND MARINE GAS TURBINE ENGINE PARTS; WHOLESALE STORE SERVICES IN THE FIELD OF AIRCRAFT, INDUSTRIAL AND MARINE GAS TURBINE ENGINE PARTS; DISTRIBUTORSHIPS IN THE FIELD OF AIRCRAFT, INDUSTRIAL AND MARINE GAS TURBINE ENGINE PARTS; BUSINESS CONSULTATION SERVICES IN THE FIELD OF AIRCRAFT, INDUSTRIAL AND MARINE GAS TURBINE ENGINE PARTS AND MAINTENANCE; AND RETAIL CONSIGNMENT STORE SERVICES IN THE FIELD OF AIRCRAFT, INDUSTRIAL AND MARINE GAS TURBINE ENGINE PARTS (U.S. CLS. 100, 101 AND 102).

FIRST USE 6-15-1995; IN COMMERCE 6-15-1995.

CLASS 37—CONSTRUCTION AND REPAIR

FOR REPAIRS AND INSTALLATION SERVICES OF AIRCRAFT, INDUSTRIAL AND MARINE GAS TURBINE ENGINE COMPONENTS, ACCESSORIES AND ASSEMBLIES; TECHNICAL CONSULTATION IN THE FIELD OF AIRCRAFT, INDUSTRIAL AND MARINE GAS TURBINE ENGINE PARTS MAINTENANCE (U.S. CLS. 100, 103 AND 106).

FIRST USE 6-15-1995; IN COMMERCE 6-15-1995.

CIMMERIAN COLEMAN, EXAMINING ATTORNEY

SN 85-259,662. DESIGN WITHIN REACH, INC., STAMFORD, CT. FILED 3-7-2011.



OWNER OF U.S. REG. NOS. 2,493,177, 3,009,987 AND 3,279,622.

THE COLOR(S) RED AND WHITE IS/ARE CLAIMED AS A FEATURE OF THE MARK.

THE MARK CONSISTS OF A RED RECTANGLE, WITHIN THIS RECTANGLE APPEARS A THIN WHITE LINE, WHICH ALSO FORMS A RECTANGLE, AND IS SUPERIMPOSED OVER THE RED RECTANGLE. THE WORDING "DESIGN WITHIN REACH" APPEARS IN WHITE STYLED FONT WITHIN THE INNER RECTANGLE FORMED BY THE THIN WHITE LINE. "DESIGN" IS STACKED ABOVE "WITHIN", "WITHIN" IS STACKED ABOVE "REACH". THE MARK IN ITS ENTIRETY APPEARS ON A TRANSPARENT BACKGROUND.

CLASS 16—PAPER GOODS AND PRINTED MATTER

FOR CATALOGS AND PERIODICALS, IN THE FIELDS OF FURNITURE, HOUSEWARES AND RELATED PRODUCTS (U.S. CLS. 2, 5, 22, 23, 29, 37, 38 AND 50).

FIRST USE 7-1-1999; IN COMMERCE 7-1-1999.

CLASS 35—ADVERTISING AND BUSINESS

FOR ONLINE AND CATALOG MAIL ORDER AND RETAIL STORE SERVICES IN THE FIELDS OF FURNITURE, HOUSEWARES AND RELATED PRODUCTS, AND CONSULTING RELATED THERETO (U.S. CLS. 100, 101 AND 102).

FIRST USE 4-1-1999; IN COMMERCE 7-1-1999.

CLASS 41—EDUCATION AND ENTERTAINMENT

FOR ONLINE NEWSLETTERS IN THE FIELDS OF FURNITURE, HOUSEWARES AND RELATED PRODUCTS (U.S. CLS. 100, 101 AND 107).

FIRST USE 11-18-1999; IN COMMERCE 11-18-1999.
GRETCHEN ULRICH, EXAMINING ATTORNEY

SN 85-261,870. WHAT A PIX, INC., HOUSTON, TX. FILED 3-9-2011.



THE MARK CONSISTS OF THE STYLIZED WORD "WHATAPIX" WHEREIN THE TERM "PIX" IS LOCATED INSIDE A SKEWED SQUARE AND THE LETTER "I" IN THE TERM "PIX" IS SHOWN AS AN EXCLAMATION POINT LOCATED BETWEEN THE LETTERS "P" AND THE "X".

SN 85-261,720. INDOOR BIOTECHNOLOGIES, INC., CHARLOTTESVILLE, VA. FILED 3-9-2011.

MARIA

THE MARK CONSISTS OF STANDARD CHARACTERS WITHOUT CLAIM TO ANY PARTICULAR FONT, STYLE, SIZE, OR COLOR.

CLASS 1—CHEMICALS

FOR MULTIPLEX KITS COMPRISED OF ASSAYS FOR TESTING FOR ALLERGENS FOR RESEARCH PURPOSES (U.S. CLS. 1, 5, 6, 10, 26 AND 46).

FIRST USE 4-3-2008; IN COMMERCE 4-3-2008.

CLASS 5—PHARMACEUTICALS

FOR MULTIPLEX KITS COMPRISED OF ASSAYS FOR TESTING FOR ALLERGENS FOR MEDICAL PURPOSES (U.S. CLS. 6, 18, 44, 46, 51 AND 52).

FIRST USE 4-3-2008; IN COMMERCE 4-3-2008.
KAREN SEVERSON, EXAMINING ATTORNEY

CLASS 9—ELECTRICAL AND SCIENTIFIC APPARATUS

FOR DOWNLOADABLE SOFTWARE FOR USE IN CREATING PERSONALIZED PHOTO BOOKS, CALENDARS, CARDS, AND POSTERS (U.S. CLS. 21, 23, 26, 36 AND 38).

CLASS 40—MATERIAL TREATMENT

FOR DIGITAL ON DEMAND PRINTING SERVICES OF PERSONALIZED PHOTO BOOKS, CALENDARS, CARDS, AND POSTERS (U.S. CLS. 100, 103 AND 106).

MICHAEL TANNER, EXAMINING ATTORNEY

SN 85-261,851. WHAT A PIX, INC., HOUSTON, TX. FILED 3-9-2011.

WHATAPIX

THE MARK CONSISTS OF STANDARD CHARACTERS WITHOUT CLAIM TO ANY PARTICULAR FONT, STYLE, SIZE, OR COLOR.

CLASS 9—ELECTRICAL AND SCIENTIFIC APPARATUS

FOR DOWNLOADABLE SOFTWARE FOR USE IN CREATING PERSONALIZED PHOTO BOOKS, CALENDARS, CARDS, AND POSTERS (U.S. CLS. 21, 23, 26, 36 AND 38).

CLASS 40—MATERIAL TREATMENT

FOR DIGITAL ON DEMAND PRINTING SERVICES OF PERSONALIZED PHOTO BOOKS, CALENDARS, CARDS, AND POSTERS (U.S. CLS. 100, 103 AND 106).

MICHAEL TANNER, EXAMINING ATTORNEY

SN 85-262,149. AVIATION, POWER & MARINE, INC., BOYTON BEACH, FL. FILED 3-9-2011.



THE MARK CONSISTS OF THREE STYLIZED ARC SEGMENTS AND THE WORDING "AP+M" IN LOWER-CASE.

CLASS 35—ADVERTISING AND BUSINESS

FOR RETAIL STORE SERVICES IN THE FIELD OF AIRCRAFT, INDUSTRIAL AND MARINE GAS TURBINE ENGINE PARTS; WHOLESALE STORE SERVICES IN THE FIELD OF AIRCRAFT, INDUSTRIAL AND MARINE GAS TURBINE ENGINE PARTS; DISTRIBUTORSHIPS IN THE FIELD OF AIRCRAFT, INDUSTRIAL AND MARINE GAS TURBINE ENGINE PARTS; BUSINESS CONSULTATION SERVICES IN THE FIELD OF AIRCRAFT, INDUSTRIAL AND MARINE GAS TURBINE ENGINE PARTS AND MAINTENANCE; AND RETAIL CONSIGNMENT STORE SERVICES IN THE FIELD OF AIRCRAFT, INDUSTRIAL AND MARINE GAS TURBINE ENGINE PARTS (U.S. CLS. 100, 101 AND 102).

CLASS 37—CONSTRUCTION AND REPAIR

FOR REPAIRS AND INSTALLATION SERVICES OF AIRCRAFT, INDUSTRIAL AND MARINE GAS TURBINE ENGINE COMPONENTS, ACCESSORIES AND ASSEMBLIES; TECHNICAL CONSULTATION IN THE FIELD OF AIRCRAFT, INDUSTRIAL AND MARINE GAS TURBINE ENGINE PARTS MAINTENANCE (U.S. CLS. 100, 103 AND 106).

CIMMERIAN COLEMAN, EXAMINING ATTORNEY

SN 85-262,694. UNITED STATES DEPARTMENT OF ENERGY, WASHINGTON, DC. FILED 3-9-2011.

Clean Cities

THE MARK CONSISTS OF STANDARD CHARACTERS WITHOUT CLAIM TO ANY PARTICULAR FONT, STYLE, SIZE, OR COLOR.

CLASS 16—PAPER GOODS AND PRINTED MATTER

FOR PRINTED PUBLICATIONS, NAMELY, NEWSLETTERS, INFORMATIONAL MANUALS, AND LEAFLETS, ALL FEATURING INFORMATION REGARDING ALTERNATIVE FUEL VEHICLES (U.S. CLS. 2, 5, 22, 23, 29, 37, 38 AND 50).

FIRST USE 4-0-1993; IN COMMERCE 8-0-1994.

CLASS 35—ADVERTISING AND BUSINESS

FOR PROMOTING PUBLIC AWARENESS OF THE NEED FOR ALTERNATIVE FUEL VEHICLES, VIA A GLOBAL COMPUTER NETWORK (U.S. CLS. 100, 101 AND 102).

FIRST USE 4-0-1993; IN COMMERCE 6-0-1994.

CLASS 41—EDUCATION AND ENTERTAINMENT

FOR EDUCATIONAL SERVICES, NAMELY, CONDUCTING WORKSHOPS IN THE FIELD OF PROMOTING THE USE AND VIABILITY OF ALTERNATIVE FUEL VEHICLES; PROVIDING ON-LINE NEWSLETTERS, INFORMATIONAL MANUALS, AND LEAFLETS, ALL FEATURING INFORMATION REGARDING ALTERNATIVE FUEL VEHICLES (U.S. CLS. 100, 101 AND 107).

FIRST USE 4-0-1993; IN COMMERCE 9-0-1995.

GINA FINK, EXAMINING ATTORNEY

SN 85-262,783. SUPREME SURFACE, INC, INDIANAPOLIS, IN. FILED 3-9-2011.

SUPREME SURFACE

THE MARK CONSISTS OF STANDARD CHARACTERS WITHOUT CLAIM TO ANY PARTICULAR FONT, STYLE, SIZE, OR COLOR.

NO CLAIM IS MADE TO THE EXCLUSIVE RIGHT TO USE "SURFACE", APART FROM THE MARK AS SHOWN.

CLASS 3—COSMETICS AND CLEANING PREPARATIONS

FOR CLEANER FOR USE ON BATHROOM FIXTURES, KITCHEN FIXTURES, FLOORING, WALLS AND OTHER HARD ITEMS (U.S. CLS. 1, 4, 6, 50, 51 AND 52).

FIRST USE 12-25-2010; IN COMMERCE 12-25-2010.

CLASS 35—ADVERTISING AND BUSINESS

FOR RETAIL STORE AND ON-LINE RETAIL STORE SERVICES FEATURING KITCHEN FIXTURES, BATHROOM FIXTURES, FLOORING AND DECORATIVE PRODUCTS (U.S. CLS. 100, 101 AND 102).

FIRST USE 10-1-1996; IN COMMERCE 10-1-1996.

JULIE GUTTADAURO, EXAMINING ATTORNEY

SN 85-262,952. NOVA/TCB USA INC., POWELL, TN. FILED 3-10-2011.



NO CLAIM IS MADE TO THE EXCLUSIVE RIGHT TO USE "USA INC.", APART FROM THE MARK AS SHOWN.

THE COLOR(S) RED AND BLACK IS/ARE CLAIMED AS A FEATURE OF THE MARK.

THE MARK CONSISTS OF THE WORDS "NOVA/TCB" IN BLACK WITH A GRAPHIC OF A ROUND, RED AND BLACK BEARING REPLACING THE LETTER "O" IN "NOVA" AND THE WORDS "USA INC." IN BLACK.

CLASS 6—METAL GOODS

FOR STEEL PIPES AND TUBES (U.S. CLS. 2, 12, 13, 14, 23, 25 AND 50).

FIRST USE 1-1-2005; IN COMMERCE 1-1-2005.

CLASS 7—MACHINERY

FOR BEARINGS FOR TRANSMISSION SHAFTS, BEING PARTS OF MACHINES; BEARINGS, AS PARTS OF MACHINES; GEARS FOR MACHINES; ROLLER BEARINGS FOR MACHINES (U.S. CLS. 13, 19, 21, 23, 31, 34 AND 35).

FIRST USE 1-1-2005; IN COMMERCE 1-1-2005.

JACQUELINE A. LAVINE, EXAMINING ATTORNEY

SN 85-262,998. OPEL SOLAR INC., SHELTON, CT. FILED 3-10-2011.

OPEL Solar

THE MARK CONSISTS OF STANDARD CHARACTERS WITHOUT CLAIM TO ANY PARTICULAR FONT, STYLE, SIZE, OR COLOR.

OWNER OF U.S. REG. NO. 3,946,702.

NO CLAIM IS MADE TO THE EXCLUSIVE RIGHT TO USE "SOLAR", APART FROM THE MARK AS SHOWN.

SEC. 2(F).

CLASS 6—METAL GOODS

FOR METAL STRUCTURES FOR MOUNTING SOLAR PANELS; SOLAR PANEL MOUNTS MADE OF METAL; SUBSTRATES PRIMARILY OF METAL FOR SUPPORTING SOLAR CELLS, PHOTOVOLTAIC CELLS AND SOLAR COLLECTORS (U.S. CLS. 2, 12, 13, 14, 23, 25 AND 50).

FIRST USE 1-1-2010; IN COMMERCE 1-1-2010.

CLASS 7—MACHINERY

FOR MOTORS, GEARS AND DRIVES FOR ORIENTATING SOLAR PANELS (U.S. CLS. 13, 19, 21, 23, 31, 34 AND 35).

FIRST USE 1-1-2010; IN COMMERCE 1-1-2010.

CLASS 9—ELECTRICAL AND SCIENTIFIC APPARATUS

FOR APPARATUS FOR CONVERTING SOLAR RADIATION TO ELECTRICAL ENERGY, NAMELY, PHOTOVOLTAIC SOLAR MODULES, PHOTOVOLTAIC SOLAR HYBRID MODULES, PHOTOVOLTAIC THERMAL MODULE, PVT MODULE AND SOLAR CONCENTRATING PANELS; APPARATUS FOR CONVERTING ELECTRONIC RADIATION TO ELECTRICAL ENERGY, NAMELY, PHOTOVOLTAIC SOLAR MODULES AND PHOTOVOLTAIC ROOFING MEMBERS; HEAT SINKS FOR TRIPLE JUNCTION PHOTOVOLTAIC CELLS; HEAT SINKS FOR USE IN PHOTOVOLTAIC CELLS AND ELECTRONIC COMPONENTS CONCENTRATORS; MAGNIFYING LENSES AND OPTICAL LENSES; PHOTOVOLTAIC CELLS AND MODULES; SILCON SOLAR CELL MATERIAL FOR ELECTRICITY GENERATION INCORPORATED INTO PAVEMENT MATERIALS; AND SOLAR CELLS (U.S. CLS. 21, 23, 26, 36 AND 38).

FIRST USE 1-1-2010; IN COMMERCE 1-1-2010.

CLASS 11—ENVIRONMENTAL CONTROL APPARATUS

FOR HEAT SINKS FOR USE IN HEATING, COOLING AND VENTILATING APPARATUS; PHOTOVOLTAIC-BASED POWER PLANTS; HEAT SINKS FOR USE IN HEATING, COOLING AND VENTILATING APPARATUS, NAMELY, SOLAR CONCENTRATORS AND COLLECTORS (U.S. CLS. 13, 21, 23, 31 AND 34).

FIRST USE 1-1-2010; IN COMMERCE 1-1-2010.

CLASS 17—RUBBER GOODS

FOR SUBSTRATES PRIMARILY OF CERAMIC SILICON AND NON-METALS FOR ELECTRICAL OR THERMAL INSULATION OF SOLAR CELLS, PHOTOVOLTAIC CELLS, AND SOLAR COLLECTORS (U.S. CLS. 1, 5, 12, 13, 35 AND 50).

FIRST USE 1-1-2010; IN COMMERCE 1-1-2010.

CLASS 19—NON-METALLIC BUILDING MATERIALS

FOR NON-METAL STRUCTURES FOR MOUNTING SOLAR PANELS (U.S. CLS. 1, 12, 33 AND 50).

FIRST USE 1-1-2010; IN COMMERCE 1-1-2010.

CLASS 37—CONSTRUCTION AND REPAIR

FOR INSTALLATION AND MAINTENANCE OF PHOTOVOLTAIC INSTALLATIONS (U.S. CLS. 100, 103 AND 106).

FIRST USE 1-1-2010; IN COMMERCE 1-1-2010.

CLASS 42—SCIENTIFIC AND COMPUTER SERVICES

FOR DESIGN OF SOLAR PHOTOVOLTAIC SYSTEMS; DRAFTING AND DEVELOPMENT OF PHOTOVOLTAIC SYSTEMS; TECHNICAL PLANNING OF PHOTOVOLTAIC INSTALLATIONS (U.S. CLS. 100 AND 101).

FIRST USE 1-1-2010; IN COMMERCE 1-1-2010.
FRANK LATTUCA, EXAMINING ATTORNEY

SN 85-263,364. WILLIAM GARAFFA, SNOWMASS VILLAGE, CO. FILED 3-10-2011.



THE MARK CONSISTS OF A GEOMETRIC DESIGN WHICH CONSISTS OF AN UPPER CASE LETTER "G" CONNECTED TO AN UPPER CASE BACKWARD LETTER "G". THE TWO UPPER CASE LETTER "G'S" ARE ATTACHED TO AN UPSIDE DOWN UPPER CASE LETTER "T".

CLASS 18—LEATHER GOODS

FOR HANDBAGS (U.S. CLS. 1, 2, 3, 22 AND 41).

CLASS 25—CLOTHING

FOR CLOTHING, NAMELY, TOPS, BOTTOMS, DRESSES, AND JACKETS; CLOTHING ACCESSORIES, NAMELY, BELTS (U.S. CLS. 22 AND 39).

KHANH LE, EXAMINING ATTORNEY

SN 85-263,705. WALKER, JEAN ERICKSON, DBA JEAN ERICKSON WALKER, LAKE OSWEGO, OR. FILED 3-10-2011.



THE COLOR(S) RED, MAROON, ORANGE, YELLOW, GRAY AND WHITE IS/ARE CLAIMED AS A FEATURE OF THE MARK.

THE MARK CONSISTS OF A DESIGN OF A GRAY AND WHITE TORCH WITH RED, ORANGE AND YELLOW FLAMES. A WAVY HORIZONTAL BAND IN MAROON AND RED BISECTS THE BOTTOM HALF OF THE TORCH HANDLE.

CLASS 35—ADVERTISING AND BUSINESS

FOR BUSINESS CONSULTATION IN THE FIELD OF BUSINESS LEADERSHIP DEVELOPMENT; BUSINESS MANAGEMENT CONSULTATION IN THE FIELD OF EXECUTIVE AND LEADERSHIP DEVELOPMENT; PROVIDING EMPLOYMENT COUNSELING INFORMATION ON HOW TO SUCCESSFULLY TRANSITION JOBS; PROVIDING EMPLOYMENT COUNSELING INFORMATION ON HOW TO SUCCESSFULLY TRANSITION JOBS FOR MATURE WORKERS (U.S. CLS. 100, 101 AND 102).

FIRST USE 2-23-2011; IN COMMERCE 2-23-2011.

CLASS 41—EDUCATION AND ENTERTAINMENT

FOR PROFESSIONAL COACHING SERVICES IN THE FIELD OF CAREER COUNSELING, EXECUTIVE COACHING, LEADERSHIP DEVELOPMENT AND BUSINESS MANAGEMENT (U.S. CLS. 100, 101 AND 107).

FIRST USE 2-23-2011; IN COMMERCE 2-23-2011.

HAI-LY LAM, EXAMINING ATTORNEY

SN 85-264,652. AUTOMATCHERS, LLC, GREENWICH, CT. FILED 3-11-2011.

automotive soul mate

THE MARK CONSISTS OF STANDARD CHARACTERS WITHOUT CLAIM TO ANY PARTICULAR FONT, STYLE, SIZE, OR COLOR.

NO CLAIM IS MADE TO THE EXCLUSIVE RIGHT TO USE "AUTOMOTIVE", APART FROM THE MARK AS SHOWN.

SN 85-264,512. POWERDYNE, INC., NEWPORT BEACH, CA. FILED 3-11-2011.

POWERDYNE

THE MARK CONSISTS OF STANDARD CHARACTERS WITHOUT CLAIM TO ANY PARTICULAR FONT, STYLE, SIZE, OR COLOR.

CLASS 10—MEDICAL APPARATUS

FOR CONTAINERS FOR MEDICAL WASTE (U.S. CLS. 26, 39 AND 44).

CLASS 11—ENVIRONMENTAL CONTROL APPARATUS

FOR COAL POWER PLANTS; SOLAR POWER PLANTS (U.S. CLS. 13, 21, 23, 31 AND 34).

CLASS 35—ADVERTISING AND BUSINESS

FOR COMMERCIAL ADMINISTRATION OF THE LICENSING OF CLEAN COAL AND SOLAR POWER TECHNOLOGY OF OTHERS (U.S. CLS. 100, 101 AND 102).

CLASS 37—CONSTRUCTION AND REPAIR

FOR MEDICAL WASTE DISPOSAL; SOLID WASTE LANDFILL SERVICES (U.S. CLS. 100, 103 AND 106).

CLASS 40—MATERIAL TREATMENT

FOR MEDICAL WASTE TREATMENT INCLUDING RECYCLING OF WASTE; MEDICAL WASTE DECONTAMINATION SERVICES; RECYCLING, NAMELY, PROCESSING AND TREATMENT OF MUNICIPAL SOLID WASTE; RECYCLING, NAMELY, CONVERTING SOLID WASTE INTO FUEL; MATERIAL PROCESSING, NAMELY, CONVERSION OF CARBONACEOUS MATERIAL SUCH AS WASTE AND COAL INTO VARIOUS PRODUCTS SUCH AS CHEMICAL FEED STOCK (U.S. CLS. 100, 103 AND 106).

CLASS 42—SCIENTIFIC AND COMPUTER SERVICES

FOR RESEARCH AND DEVELOPMENT IN THE FIELD OF CONVERTING COAL COMBUSTION TO STEAM FOR ALTERNATIVE ENERGY (U.S. CLS. 100 AND 101).

CLASS 45—PERSONAL AND LEGAL SERVICES

FOR LICENSING OF CLEAN COAL AND SOLAR POWER TECHNOLOGY (U.S. CLS. 100 AND 101).
WILLIAM BRECKENFELD, EXAMINING ATTORNEY

CLASS 35—ADVERTISING AND BUSINESS

FOR ADVERTISING AND DIRECTORY SERVICES, NAMELY, PROMOTING THE SERVICES OF OTHERS BY PROVIDING A WEB PAGE FEATURING LINKS TO THE WEBSITES OF OTHERS; PROMOTION, ADVERTISING AND MARKETING OF ON-LINE WEBSITES; PROVIDING A SEARCHABLE ON-LINE ADVERTISING WEBSITE AND GUIDE FEATURING THE GOODS AND SERVICES OF OTHER VENDORS VIA THE INTERNET; PROVIDING A SEARCHABLE ONLINE ADVERTISING WEBSITE AND INFORMATIONAL GUIDE FEATURING THE GOODS AND SERVICES OF OTHER VENDORS VIA THE INTERNET IN THE FIELD OF CARS AND TRUCKS; PROVIDING A SEARCHABLE WEBSITE FEATURING THE GOODS AND SERVICES OF OTHER VENDORS; PROVIDING ADVERTISING SERVICE TO DISTRIBUTE ADVERTISEMENTS FOR DISPLAY ON INTERNET, NAMELY, IN WEBSITES, SOCIAL CONVERSATIONS OVER THE INTERNET, E-MAILS, MICROBLOGS, BLOGS, ELECTRONIC MESSAGES, INSTANT MESSAGES, TEXT MESSAGES, MULTIMEDIA MESSAGES, SOCIAL NETWORKS, STATUS UPDATES, FORUMS, ELECTRONIC BULLETIN BOARDS (U.S. CLS. 100, 101 AND 102).

CLASS 42—SCIENTIFIC AND COMPUTER SERVICES

FOR PROVIDING A MEMBERS-ONLY WEBSITE FEATURING TECHNOLOGY WHICH PROVIDES MEMBERS WITH THE ABILITY TO ACCESS MULTIPLE DATABASES AND AUTOMOBILE INDUSTRY SERVICES FOR THE PURPOSE OF CONDUCTING AUTOMOBILE PURCHASE AND SALE TRANSACTIONS (U.S. CLS. 100 AND 101).

HAI-LY LAM, EXAMINING ATTORNEY

SN 85-264,755. KRAFT FOODS SCHWEIZ HOLDING GMBH, 6301 ZUG, SWITZERLAND, FILED 3-11-2011.



OWNER OF U.S. REG. NOS. 3,030,372, 3,168,052 AND OTHERS.

NO CLAIM IS MADE TO THE EXCLUSIVE RIGHT TO USE "INTELLIGENT SYSTEM", APART FROM THE MARK AS SHOWN.

THE MARK CONSISTS OF A BLACK TEARDROP SHAPED IMAGE WITH THE POINT IN THE LOWER LEFT CORNER. THERE IS A LIGHTER COLORED OUTLINE SURROUNDING THE BLACK IMAGE. IN THE LOWER LEFT CORNER ARE THE WORDS "TASSIMO INTELLIGENT SYSTEM". IN THE ROUNDED PORTION OF THE IMAGE WHICH IS IN THE UPPER RIGHT CORNER ARE ELEVEN RECTANGLES PRINTED SIDE BY SIDE WITH THE ONE ON THE LEFT BEING THE DARKEST COLOR AND THE REMAINING RECTANGLES GETTING PROGRESSIVELY LIGHTER IN COLOR.

CLASS 11—ENVIRONMENTAL CONTROL APPARATUS

FOR ELECTRIC COFFEE MAKERS (U.S. CLS. 13, 21, 23, 31 AND 34).

CLASS 30—STAPLE FOODS

FOR COFFEE; HOT CHOCOLATE; TEA (U.S. CL. 46).
MATTHEW EINSTEIN, EXAMINING ATTORNEY

SN 85-264,826. SOLUCION LLC, HUNTERSVILLE, NC. FILED 3-11-2011.



THE MARK CONSISTS OF THE WORD "SOLUCION" WITH AN ACCENT SIGN OVER THE SECOND "O" AND A CONGRUENCE SYMBOL IN FRONT OF THE LETTER "S". THE ENGLISH TRANSLATION OF "SOLUCIÓN" IN THE MARK IS "SOLUTION".

CLASS 35—ADVERTISING AND BUSINESS

FOR BUSINESS MANAGEMENT SERVICES (U.S. CLS. 100, 101 AND 102).

CLASS 40—MATERIAL TREATMENT

FOR ASSEMBLY OF PRODUCTS FOR OTHERS (U.S. CLS. 100, 103 AND 106).
HAI-LY LAM, EXAMINING ATTORNEY

SN 85-265,060. SECUREFORCE, LLC, STERLING, VA. FILED 3-11-2011.



THE MARK CONSISTS OF STANDARD CHARACTERS WITHOUT CLAIM TO ANY PARTICULAR FONT, STYLE, SIZE, OR COLOR.

CLASS 41—EDUCATION AND ENTERTAINMENT

FOR TRAINING IN THE FIELD OF SECURITY AWARENESS FOR COMPUTER NETWORKS, HARDWARE AND SOFTWARE (U.S. CLS. 100, 101 AND 107).
FIRST USE 12-0-2003; IN COMMERCE 12-0-2003.

CLASS 42—SCIENTIFIC AND COMPUTER SERVICES

FOR CONSULTATION SERVICES RELATED TO COMPUTER NETWORK SECURITY, DATA ASSET MANAGEMENT, SYSTEMS INTEGRATION AND REGULATORY COMPLIANCE; CONSULTATION SERVICES RELATED TO THE DESIGN, DEVELOPMENT, PROCUREMENT, IMPLEMENTATION, OPERATION, TESTING AND MAINTENANCE OF ELECTRONIC COMMUNICATIONS NETWORKS, ELECTRONIC INFORMATION SYSTEMS AND COMPUTER SOFTWARE; DESIGN, DEVELOPMENT AND IMPLEMENTATION OF COMPUTER SOFTWARE; DESIGN, DEVELOPMENT AND CONFIGURATION OF COMPUTER HARDWARE; TECHNICAL ANALYSIS OF COMPUTER NETWORKS AND ELECTRONIC INFORMATION SYSTEMS; APPLICATION SERVICE PROVIDER FEATURING SOFTWARE FOR USE IN UPLOADING, ANALYZING AND REPORTING NETWORK SECURITY DATA AND INFORMATION (U.S. CLS. 100 AND 101).

FIRST USE 12-0-2003; IN COMMERCE 12-0-2003.
HEATHER THOMPSON, EXAMINING ATTORNEY

SN 85-265,309. TOP GUN CUSTOMZ, INC., ALCOA, TN. FILED 3-12-2011.



THE MARK CONSISTS OF STANDARD CHARACTERS WITHOUT CLAIM TO ANY PARTICULAR FONT, STYLE, SIZE, OR COLOR.

NO CLAIM IS MADE TO THE EXCLUSIVE RIGHT TO USE "CUSTOMS", APART FROM THE MARK AS SHOWN.

CLASS 12—VEHICLES

FOR AUTOMOTIVE CONVERSION KITS COMPRISED OF SUSPENSION MECHANISMS TO MAKE STRUCTURAL CHANGES TO AN AUTOMOBILE; SHOCK ABSORBERS FOR AUTOMOBILES; STRUCTURAL PARTS FOR AUTOMOBILES; STRUCTURAL PARTS FOR TRUCKS (U.S. CLS. 19, 21, 23, 31, 35 AND 44).

FIRST USE 12-25-2003; IN COMMERCE 2-26-2007.

CLASS 35—ADVERTISING AND BUSINESS

FOR DISTRIBUTORSHIP SERVICES IN THE FIELD OF AFTERMARKET AUTOMOTIVE PARTS; RESELLER SERVICES, NAMELY, DISTRIBUTORSHIP SERVICES IN THE FIELD OF AFTERMARKET AUTOMOTIVE PARTS (U.S. CLS. 100, 101 AND 102).

FIRST USE 12-25-2003; IN COMMERCE 2-26-2007.

CLASS 37—CONSTRUCTION AND REPAIR

FOR AUTOMOBILE CUSTOMIZATION SERVICES; AUTOMOTIVE CONVERSION SERVICES, NAMELY, INSTALLING SPECIALTY AUTOMOTIVE EQUIPMENT; INSTALLATION OF AFTERMARKET AUTOMOTIVE PARTS (U.S. CLS. 100, 103 AND 106).

FIRST USE 12-25-2003; IN COMMERCE 2-26-2007.
NAAKWAMA ANKRAH, EXAMINING ATTORNEY

SN 85-265,475. MPS MULTIMEDIA, INC., DBA SELECTSOFT PUBLISHING, SAN MATEO, CA. FILED 3-12-2011.

PLAYVATAR

THE MARK CONSISTS OF STANDARD CHARACTERS WITHOUT CLAIM TO ANY PARTICULAR FONT, STYLE, SIZE, OR COLOR.

CLASS 9—ELECTRICAL AND SCIENTIFIC APPARATUS

FOR ELECTRONIC GAME PROGRAMS; SOFTWARE FOR CELLULAR PHONES AND FOR TABLET COMPUTERS FOR CREATING CUSTOMIZABLE CHARACTERS FOR ELECTRONIC GAMES; SOFTWARE FOR CELLULAR PHONES AND FOR TABLET COMPUTERS FOR CREATING CUSTOMIZABLE CLOTHING FOR CHARACTERS IN ELECTRONIC GAMES (U.S. CLS. 21, 23, 26, 36 AND 38).

CLASS 41—EDUCATION AND ENTERTAINMENT

FOR ENTERTAINMENT SERVICES, NAMELY, PROVIDING ONLINE ELECTRONIC GAMES; PROVIDING ONLINE MULTIPLAYER GAMES; PROVIDING ONLINE GAMES FOR CELLULAR PHONES AND TABLET COMPUTERS IN WHICH USERS CAN INTERACT SOCIALLY (U.S. CLS. 100, 101 AND 107).

KIM SAITO, EXAMINING ATTORNEY

SN 85-265,794. BRAIN CANDY, SARL, MONTREUIL, FRANCE, FILED 3-14-2011.

FRAY

THE MARK CONSISTS OF STANDARD CHARACTERS WITHOUT CLAIM TO ANY PARTICULAR FONT, STYLE, SIZE, OR COLOR.

PRIORITY CLAIMED UNDER SEC. 44(D) ON FRANCE APPLICATION NO. 103765956, FILED 9-13-2010, REG. NO. 103765956, DATED 1-28-2011, EXPIRES 9-13-2020.

CLASS 9—ELECTRICAL AND SCIENTIFIC APPARATUS

FOR VIDEO GAME SOFTWARE FOR, AND DELIVERED DIGITALLY TO, PERSONAL COMPUTERS, VIDEO GAME CONSOLES, TABLET COMPUTERS, MOBILE PHONES, AND HANDHELD ELECTRONIC DEVICES, IN THE FIELD OF A SCIENCE-FICTION MULTI-PLAYER STRATEGY GAMES, NOT FOR SLOT MACHINES, CASINO GAMING MACHINES, WAGER GAMING MACHINES, OR MACHINES FOR PLAYING GAMES OF CHANCE (U.S. CLS. 21, 23, 26, 36 AND 38).

CLASS 41—EDUCATION AND ENTERTAINMENT

FOR ENTERTAINMENT SERVICES, NAMELY, PROVIDING ONLINE VIDEO GAMES IN THE FIELD OF A SCIENCE-FICTION MULTI-PLAYER STRATEGY GAMES, NOT IN THE NATURE OF ONLINE SLOT MACHINES, CASINO GAMING MACHINES, WAGER GAMING MACHINES, OR MACHINES FOR PLAYING GAMES OF CHANCE (U.S. CLS. 100, 101 AND 107).

NICHOLAS COLEMAN, EXAMINING ATTORNEY

SN 85-266,016. DEVAULX DE CHAMBORD XAVIER, EDGEWATER, NJ. FILED 3-14-2011.



THE MARK CONSISTS OF A CIRCLE WITH "MB MONEY BUILDERS" IN THE CENTER. A MIRROR IMAGE OF A CIRCLE WITH "MB" APPEARS UNDERNEATH.

CLASS 9—ELECTRICAL AND SCIENTIFIC APPARATUS

FOR COMPUTER SOFTWARE, NAMELY, AN APPLICATION ALLOWING SALES AND FIELD SERVICE EMPLOYEES TO UPDATE AND RECEIVE DATA STORED IN AN ENTERPRISE'S COMPUTER DATABASES IN REAL TIME, USING A MOBILE DEVICE, WITH FULL TELEPHONY INTEGRATION WITH THE TELEPHONE AND/OR SOFTWARE FEATURES OF THE MOBILE DEVICE (U.S. CLS. 21, 23, 26, 36 AND 38).

CLASS 35—ADVERTISING AND BUSINESS

FOR NEGOTIATION AND RENEGOTIATION FOR OTHERS OF LEASES AND SUBLEASES AND REAL ESTATE PURCHASE AGREEMENTS (U.S. CLS. 100, 101 AND 102).

TAMARA FRAZIER, EXAMINING ATTORNEY

SN 85-266,633. LLOYDS ASSET MANAGEMENT, WEST PALM BEACH, FL. FILED 3-14-2011.



NO CLAIM IS MADE TO THE EXCLUSIVE RIGHT TO USE "ASSET MANAGEMENT", APART FROM THE MARK AS SHOWN.

THE MARK CONSISTS OF THE STYLIZED TEXT "LAM LLOYDS ASSET MANAGEMENT".

SN 85-267,237. LUXURESSE, INC., WEST PALM BEACH, FL. FILED 3-15-2011.

CLASS 14—JEWELRY

FOR PRECIOUS METALS (U.S. CLS. 2, 27, 28 AND 50). FIRST USE 3-28-2007; IN COMMERCE 3-28-2007.

CLASS 36—INSURANCE AND FINANCIAL

FOR FINANCIAL SERVICES, NAMELY, BROKERAGE SERVICES IN THE FIELD OF GOLD, PLATINUM, SILVER, PALLADIUM AND OTHER PRECIOUS METALS (U.S. CLS. 100, 101 AND 102).

FIRST USE 3-28-2007; IN COMMERCE 3-28-2007. CHERYL CLAYTON, EXAMINING ATTORNEY

UNSUN

THE MARK CONSISTS OF STANDARD CHARACTERS WITHOUT CLAIM TO ANY PARTICULAR FONT, STYLE, SIZE, OR COLOR.

OWNER OF U.S. REG. NO. 3,660,822.

CLASS 18—LEATHER GOODS

FOR BEACH BAGS, UMBRELLAS (U.S. CLS. 1, 2, 3, 22 AND 41).

FIRST USE 9-30-2008; IN COMMERCE 11-17-2008.

CLASS 25—CLOTHING

FOR CLOTHING, NAMELY, SHIRTS, PANTS, JACKETS, FOOTWEAR, HEADWEAR, HATS, COVER-UPS, COATS, DRESSES, DRESS SHIRTS, SWIMSUITS, SWIM SHIRTS, SKIRTS, SWEATSHIRTS, SARONGS, SCARVES, SWEATERS (U.S. CLS. 22 AND 39).

FIRST USE 9-30-2008; IN COMMERCE 11-17-2008.

CIMMERIAN COLEMAN, EXAMINING ATTORNEY

SN 85-266,734. BARNES, GAVIN, NEW YORK, NY. FILED 3-14-2011.



Galimier

THE STIPLING IS FOR SHADING PURPOSES ONLY. THE MARK CONSISTS OF THE STYLIZED LETTER "Z" APPEARING INSIDE A CIRCLE BOTH OF WHICH ARE LOCATED ABOVE THE STYLIZED TERM "GALIMIER". IN THE MIDDLE OF THE DIAGONAL LINE IN THE LETTER "Z" ARE TWO VERTICAL BANDS.

THE WORDING "GALIMIER" HAS NO MEANING IN A FOREIGN LANGUAGE.

CLASS 3—COSMETICS AND CLEANING PREPARATIONS

FOR COLOGNE; COSMETICS; FRAGRANCES; MAKE-UP; PERFUME (U.S. CLS. 1, 4, 6, 50, 51 AND 52).

CLASS 25—CLOTHING

FOR COATS; FOOTWEAR; JACKETS; PANTS; SANDALS; SHIRTS; SHOES; SWEATERS (U.S. CLS. 22 AND 39).

CLASS 35—ADVERTISING AND BUSINESS

FOR RETAIL STORE SERVICES FEATURING CLOTHING JACKETS, COATS, PANTS, SHIRTS, SWEATER, PERFUME, COLOGNE, FRAGRANCES, MAKE UP AND COSMETICS, FOOTWEAR, SHOES, AND SANDALS (U.S. CLS. 100, 101 AND 102).

MICHAEL TANNER, EXAMINING ATTORNEY

SN 85-267,238. PREMIUM BALLOON ACCESSORIES, INC., SHARON CENTER, OH. FILED 3-15-2011.

PREMIUM BALLOON ACCESSORIES

THE MARK CONSISTS OF STANDARD CHARACTERS WITHOUT CLAIM TO ANY PARTICULAR FONT, STYLE, SIZE, OR COLOR.

OWNER OF U.S. REG. NOS. 2,078,746, 2,495,160 AND 3,321,163.

NO CLAIM IS MADE TO THE EXCLUSIVE RIGHT TO USE "BALLOON ACCESSORIES", APART FROM THE MARK AS SHOWN.

SEC. 2(F).

CLASS 7—MACHINERY

FOR BALLOON INFLATORS FOR LATEX AND FOIL BALLOONS (U.S. CLS. 13, 19, 21, 23, 31, 34 AND 35).

FIRST USE 1-1-1990; IN COMMERCE 1-1-1990.

CLASS 9—ELECTRICAL AND SCIENTIFIC APPARATUS

FOR HEAT SEALING MACHINES FOR SEALING FOIL BALLOONS (U.S. CLS. 21, 23, 26, 36 AND 38).

FIRST USE 1-1-1990; IN COMMERCE 1-1-1990.

CLASS 28—TOYS AND SPORTING GOODS

FOR WEIGHTS TO RESTRAIN LIGHTER-THAN-AIR BALLOONS, BALLOON HOLDERS IN THE FORM OF PLASTIC STICKS AND CUPS, AND BALLOON SEALS IN THE FORM OF PLASTIC SEALS SECURED AT THE NECK OF AN INFLATED BALLOON (U.S. CLS. 22, 23, 38 AND 50).

FIRST USE 1-1-1990; IN COMMERCE 1-1-1990.

LESLIE RICHARDS, EXAMINING ATTORNEY

SN 85-267,495. ZELTIQ AESTHETICS, INC., PLEASANTON, CA. FILED 3-15-2011.

SN 85-267,569. THE CHRISTIAN AND MISSIONARY ALLIANCE FOUNDATION, INC., FT. MYERS, FL. FILED 3-15-2011.

COOLBODY

THE MARK CONSISTS OF STANDARD CHARACTERS WITHOUT CLAIM TO ANY PARTICULAR FONT, STYLE, SIZE, OR COLOR.

OWNER OF U.S. REG. NOS. 3,921,045 AND 3,957,850.

CLASS 10—MEDICAL APPARATUS

FOR MEDICAL DEVICES, NAMELY, APPARATUS FOR TISSUE COOLING, CONTOURING AND CELLULITE IMPROVEMENT; MEDICAL DEVICES USED TO DESTROY FAT CELLS (U.S. CLS. 26, 39 AND 44).

CLASS 44—MEDICAL, BEAUTY AND AGRICULTURAL SERVICES

FOR MEDICAL SERVICES, NAMELY, PROCEDURES AND SERVICES IN THE NATURE OF TISSUE COOLING, CONTOURING AND CELLULITE IMPROVEMENT (U.S. CLS. 100 AND 101).

MARIA-VICTORIA SUAREZ, EXAMINING ATTORNEY

SN 85-267,526. THE CHRISTIAN AND MISSIONARY ALLIANCE FOUNDATION, INC., FT. MYERS, FL. FILED 3-15-2011.

SHELL POINT

THE MARK CONSISTS OF STANDARD CHARACTERS WITHOUT CLAIM TO ANY PARTICULAR FONT, STYLE, SIZE, OR COLOR.

CLASS 43—HOTEL AND RESTAURANT SERVICES

FOR RETIREMENT HOMES; PROVIDING INDEPENDENT LIVING RESIDENCES AND LIVING FACILITIES; PROVIDING ASSISTED LIVING FACILITIES; PROVIDING OF FOOD AND DRINK TO RESIDENTS AND GUESTS (U.S. CLS. 100 AND 101).

FIRST USE 1-1-2005; IN COMMERCE 1-1-2005.

CLASS 44—MEDICAL, BEAUTY AND AGRICULTURAL SERVICES

FOR HEALTH CARE SERVICES, NAMELY, PROVIDING SENIORS WITH NURSING CARE, MEMORY LOSS CARE, MEDICAL SERVICES, PHYSICAL REHABILITATION AND PHYSICAL THERAPY SERVICES, OCCUPATIONAL THERAPY SERVICES, AND HOSPICE CARE (U.S. CLS. 100 AND 101).

FIRST USE 1-1-2005; IN COMMERCE 1-1-2005.

BARBARA GAYNOR, EXAMINING ATTORNEY

SHELL POINT RETIREMENT COMMUNITY

THE MARK CONSISTS OF STANDARD CHARACTERS WITHOUT CLAIM TO ANY PARTICULAR FONT, STYLE, SIZE, OR COLOR.

NO CLAIM IS MADE TO THE EXCLUSIVE RIGHT TO USE "RETIREMENT COMMUNITY", APART FROM THE MARK AS SHOWN.

CLASS 43—HOTEL AND RESTAURANT SERVICES

FOR RETIREMENT HOMES; PROVIDING INDEPENDENT LIVING RESIDENCES AND LIVING FACILITIES; PROVIDING ASSISTED LIVING FACILITIES; PROVIDING OF FOOD AND DRINK TO RESIDENTS AND GUESTS (U.S. CLS. 100 AND 101).

FIRST USE 1-1-2005; IN COMMERCE 1-1-2005.

CLASS 44—MEDICAL, BEAUTY AND AGRICULTURAL SERVICES

FOR HEALTH CARE SERVICES, NAMELY, PROVIDING SENIORS WITH NURSING CARE, MEMORY LOSS CARE, MEDICAL SERVICES, PHYSICAL REHABILITATION AND PHYSICAL THERAPY SERVICES, OCCUPATIONAL THERAPY SERVICES, AND HOSPICE CARE (U.S. CLS. 100 AND 101).

FIRST USE 1-1-2005; IN COMMERCE 1-1-2005.

BARBARA GAYNOR, EXAMINING ATTORNEY

SN 85-267,738. VRINGO, INC., NEW YORK, NY. FILED 3-15-2011.

FACETONES

THE MARK CONSISTS OF STANDARD CHARACTERS WITHOUT CLAIM TO ANY PARTICULAR FONT, STYLE, SIZE, OR COLOR.

CLASS 9—ELECTRICAL AND SCIENTIFIC APPARATUS

FOR COMPUTER APPLICATION SOFTWARE FOR MOBILE DEVICES, NAMELY, SOFTWARE FOR IMPORTING A USER'S DIGITAL IMAGES FROM SOCIAL NETWORKING AND OTHER SITES, AUTOMATICALLY CREATING A SLIDESHOW, AND USING THE SLIDE SHOW AS A VIDEO RINGTONE (U.S. CLS. 21, 23, 26, 36 AND 38).

CLASS 38—COMMUNICATION

FOR TELECOMMUNICATION SERVICES, NAMELY, TRANSMISSION OF VOICE, DATA, GRAPHICS, IMAGES, AUDIO AND VIDEO BY MEANS OF TELECOMMUNICATIONS NETWORKS, WIRELESS COMMUNICATION NETWORKS, AND THE INTERNET (U.S. CLS. 100, 101 AND 104).

SUNG IN, EXAMINING ATTORNEY

SN 85-267,821. CARLA MARINA INC., FORT LEE, NJ. FILED 3-15-2011.

SN 85-268,061. GETBEEZY, LLC, WILSON, NC. FILED 3-16-2011.



THE NAME "CARLA MARINA" IDENTIFIES A LIVING INDIVIDUAL WHOSE CONSENT IS OF RECORD.

THE MARK CONSISTS OF THE SIGNATURE OF THE NAME "CARLA MARINA".

CLASS 14—JEWELRY

FOR JEWELRY (U.S. CLS. 2, 27, 28 AND 50).

CLASS 42—SCIENTIFIC AND COMPUTER SERVICES

FOR CONSULTING SERVICES IN THE FIELD OF THE DESIGN OF JEWELRY AND FASHION ACCESSORIES (U.S. CLS. 100 AND 101).

SUSAN LESLIE DUBOIS, EXAMINING ATTORNEY

SN 85-267,963. WEIDER HEALTH AND FITNESS, WOODLAND HILLS, CA. FILED 3-15-2011.

OLYMPIA WEEKEND

THE MARK CONSISTS OF STANDARD CHARACTERS WITHOUT CLAIM TO ANY PARTICULAR FONT, STYLE, SIZE, OR COLOR.

OWNER OF U.S. REG. NOS. 3,951,271, 3,951,273 AND OTHERS.

NO CLAIM IS MADE TO THE EXCLUSIVE RIGHT TO USE "WEEKEND", APART FROM THE MARK AS SHOWN.

CLASS 35—ADVERTISING AND BUSINESS

FOR ORGANIZING EXHIBITIONS FEATURING PRODUCTS AND SERVICES RELATING TO BODYBUILDING, EXERCISE, HEALTH, FITNESS AND NUTRITION FOR BUSINESS AND COMMERCIAL PURPOSES (U.S. CLS. 100, 101 AND 102).

FIRST USE 9-0-1999; IN COMMERCE 9-0-1999.

CLASS 41—EDUCATION AND ENTERTAINMENT

FOR ENTERTAINMENT SERVICES, NAMELY, ORGANIZING AND CONDUCTING BODYBUILDING CONTESTS AND COMPETITIONS, MODELING CONTESTS AND COMPETITIONS AND SHOWS FEATURING BODYBUILDING AND AWARDS CEREMONIES; EDUCATIONAL SERVICES, NAMELY, ORGANIZING AND CONDUCTING CONFERENCES AND WORKSHOPS IN THE FIELD OF BODYBUILDING, EXERCISE, HEALTH, FITNESS, NUTRITION AND COMBATING DRUG ABUSE (U.S. CLS. 100, 101 AND 107).

FIRST USE 9-0-1999; IN COMMERCE 9-0-1999.
APRIL ROACH, EXAMINING ATTORNEY

PATHCROSSER

THE MARK CONSISTS OF STANDARD CHARACTERS WITHOUT CLAIM TO ANY PARTICULAR FONT, STYLE, SIZE, OR COLOR.

CLASS 25—CLOTHING

FOR CLOTHING, NAMELY, SHIRTS, T-SHIRTS, SPORT SHIRTS, POLO SHIRTS, RUGBY SHIRTS, JERSEYS, TANK TOPS, BLOUSES, SWEATSHIRTS, SWEATERS, CARDIGANS, TURTLENECK SHIRTS, JACKETS, COATS, VESTS, SHORTS, DRESSES, PANTS, SLACKS, SWEAT PANTS, JEANS, SOCKS, NECKTIES, HEADWEAR, HATS, CAPS, KNIT CAPS, VISORS, HEADBANDS, WRIST BANDS, BELTS, SCARVES, PAJAMAS, BATHROBES, UNDERWEAR, BODY SUITS, LINGERIE, HOSIERY, STOCKINGS, GARTERS, GLOVES, MITTENS, EAR MUFFS, SUSPENDERS, BIKINIS, SWIMWEAR, SKIWEAR, RAINWEAR; ATHLETIC SUITS, NAMELY, SKI SUITS, SNOWBOARDING SUITS, TRACK SUITS, WET SUITS; APRONS; BABYWEAR, NAMELY, BABY BOTTOMS AND TOPS; TIGHTS, FOOTWEAR, SHOES, BOOTS, SLIPPERS, UNIFORMS, OVERALLS (U.S. CLS. 22 AND 39).

CLASS 42—SCIENTIFIC AND COMPUTER SERVICES

FOR COMPUTER SERVICES, NAMELY, HOSTING ON-LINE WEB FACILITIES FOR OTHERS FOR ORGANIZING AND CONDUCTING ONLINE MEETINGS, GATHERINGS, EVENTS, AND INTERACTIVE DISCUSSIONS; PROVIDING A WEBSITE THAT GIVES USERS THE ABILITY TO CREATE CUSTOMIZED WEB PAGES FEATURING USER-DEFINED INFORMATION AND USER-DEFINED PROFILES; PROVIDING CUSTOMIZED ON-LINE WEB PAGES FEATURING USER-DEFINED INFORMATION, WHICH INCLUDES SEARCH ENGINES AND ON-LINE WEB LINKS TO OTHER WEB SITES; COMPUTER SERVICES, NAMELY, HOSTING ON-LINE INTERACTIVE PUBLIC CALENDARS THAT ALLOW MULTIPLE PARTICIPANTS TO SHARE EVENT SCHEDULES, FACILITY RESERVATIONS, AND TRANSPORTATION REQUESTS (U.S. CLS. 100 AND 101).

MICHAEL TANNER, EXAMINING ATTORNEY

SN 85-268,104. TIGER BUSINESS GROUP, LLC, MECHANICSBURG, PA. FILED 3-16-2011.

I Need Solar

THE MARK CONSISTS OF STANDARD CHARACTERS WITHOUT CLAIM TO ANY PARTICULAR FONT, STYLE, SIZE, OR COLOR.

CLASS 37—CONSTRUCTION AND REPAIR

FOR INSTALLATION, REPAIR AND MAINTENANCE OF SOLAR ENERGY SYSTEMS FOR RESIDENTIAL AND COMMERCIAL USE (U.S. CLS. 100, 103 AND 106).

FIRST USE 2-18-2008; IN COMMERCE 6-1-2009.

CLASS 42—SCIENTIFIC AND COMPUTER SERVICES

FOR DESIGN OF SOLAR PHOTOVOLTAIC SYSTEMS (U.S. CLS. 100 AND 101).
FIRST USE 2-18-2008; IN COMMERCE 6-1-2009.
DAVID H. STINE, EXAMINING ATTORNEY

CHRIS WELLS, EXAMINING ATTORNEY

SN 85-268,407. S.J.HURST INC., BROOKLYN, NY. FILED 3-16-2011.



THE MARK CONSISTS OF THE STYLIZED WORDING "DOGG TAGG" WITH A STAR BETWEEN THE WORDS, APPEARING ABOVE THE TERM "21" WITHIN A CIRCLE DESIGN, AND ALL WITHIN A STYLIZED TRIANGLE DESIGN.

CLASS 18—LEATHER GOODS

FOR ATHLETIC BAGS; BACKPACKS; DOG COLLARS; DOG LEASHES; PET ACCESSORIES, NAMELY, CANVAS, VINYL AND LEATHER POUCHES FOR HOLDING DISPOSABLE BAGS TO PLACE PET WASTE IN; PET CLOTHING; SCHOOL BAGS (U.S. CLS. 1, 2, 3, 22 AND 41).

CLASS 20—FURNITURE AND ARTICLES NOT OTHERWISE CLASSIFIED

FOR CAT SCRATCHING POSTS; DOG BEDS; DOG KENNELS (U.S. CLS. 2, 13, 22, 25, 32 AND 50).
KAREN K. BUSH, EXAMINING ATTORNEY

SN 85-268,855. MEDICIS PHARMACEUTICAL CORPORATION, SCOTTSDALE, AZ. FILED 3-16-2011.

PASSION TO HEAL

THE MARK CONSISTS OF STANDARD CHARACTERS WITHOUT CLAIM TO ANY PARTICULAR FONT, STYLE, SIZE, OR COLOR.

CLASS 36—INSURANCE AND FINANCIAL

FOR CHARITABLE ACTIVITIES FOR THE PURPOSE OF FACILITATING FOREIGN AND DOMESTIC CHARITABLE MEDICAL OUTREACH, SCHOLARSHIPS AND FINANCIAL ASSISTANCE FOR THE PROGRAMS AND SERVICES OF OTHERS (U.S. CLS. 100, 101 AND 102).

CLASS 44—MEDICAL, BEAUTY AND AGRICULTURAL SERVICES

FOR CHARITABLE SERVICES, NAMELY, PROVIDING DRUGS AND MEDICAL SUPPLIES FOR THE PURPOSES OF FOREIGN AND DOMESTIC MEDICAL OUTREACH (U.S. CLS. 100 AND 101).

SN 85-268,966. LEIGH GREGORY, BURBANK, CA. FILED 3-16-2011.

TRAINEVISION

THE MARK CONSISTS OF STANDARD CHARACTERS WITHOUT CLAIM TO ANY PARTICULAR FONT, STYLE, SIZE, OR COLOR.

CLASS 9—ELECTRICAL AND SCIENTIFIC APPARATUS

FOR PRE-RECORDED VIDEOTAPES, MOTION PICTURE FILMS, PHOTOGRAPHIC SLIDE FRAMES AND AUDIO-VISUAL PROGRAMS OFFERED ON DISC AND VIA COMPUTER THROUGH DOWNLOADING FEATURING INSTRUCTION IN THE AREAS OF BUSINESS MANAGEMENT, EMPLOYEE RELATIONS, EMPLOYEE DEVELOPMENT, QUALITY CUSTOMER CARE, SALES, BUSINESS LEADERSHIP AND MARKETING (U.S. CLS. 21, 23, 26, 36 AND 38).

CLASS 16—PAPER GOODS AND PRINTED MATTER

FOR TRAINING, TEACHING, INSTRUCTIONAL AND EDUCATIONAL MATERIAL, NAMELY, BOOKS, BOOKLETS, MANUALS AND HAND-OUTS FOR EDUCATION AND BUSINESS TRAINING IN THE AREAS OF MANAGEMENT, EMPLOYEE RELATIONS, STAFF DEVELOPMENT, QUALITY, CUSTOMER CARE, SALES, LEADERSHIP AND MARKETING; PRINTED VISUALS IN THE NATURE OF INFORMATION GRAPHICS (U.S. CLS. 2, 5, 22, 23, 29, 37, 38 AND 50).
NICHOLAS COLEMAN, EXAMINING ATTORNEY

SN 85-269,284. RDPR LIMITED, BRIGHTON, EAST SUSSEX, UNITED KINGDOM, FILED 3-17-2011.

UNSPOKEN

THE MARK CONSISTS OF STANDARD CHARACTERS WITHOUT CLAIM TO ANY PARTICULAR FONT, STYLE, SIZE, OR COLOR.

CLASS 3—COSMETICS AND CLEANING PREPARATIONS

FOR SOAPS; PERFUMERY, ESSENTIAL OILS, COSMETICS, HAIR LOTIONS; DENTIFRICES; PERFUMES; PERFUMERY PRODUCTS, NAMELY, COLOGNE, AFTERSHAVE AND FRAGRANCES; AROMATIC SUBSTANCES, NAMELY, AROMATIC OILS AND AROMATIC ESSENTIAL OILS FOR USE IN THE MANUFACTURE OF PERFUMES; FINE FRAGRANCES; PERFUMED BATH FOAM PREPARATIONS, NAMELY, PERFUMED BATH FOAM AND FOAM CLEANSERS FOR PERSONAL USE; PERFUMED BATH SALTS; PERFUMED BEAUTY MILKS, BATH MILKS AND CLEANSING MILKS; PERFUMED SKIN AND BODY LOTIONS; PERFUMED BODY SPRAYS; PERFUMED SKIN AND BODY CREAMS; PERFUMED SOAPS (U.S. CLS. 1, 4, 6, 50, 51 AND 52).

CLASS 4—LUBRICANTS AND FUELS

FOR CANDLES; FRAGRANCED CANDLES; PERFUMED CANDLES (U.S. CLS. 1, 6 AND 15).
JUSTINE D. PARKER, EXAMINING ATTORNEY

CLASS 9—ELECTRICAL AND SCIENTIFIC APPARATUS

FOR ELECTRIC CONTROL DEVICES FOR HEATING AND ENERGY MANAGEMENT; ELECTRICAL ENERGY UTILIZATION METERING DEVICES COMPLETE WITH RELATED SOFTWARE; ELECTRICITY ROUTER FOR MANAGING AND OPTIMIZING ENERGY LOADS WITHIN A BUILDING; ELECTRONIC DEVICES, NAMELY, ENERGY METERS FOR TRACKING AND MONITORING ENERGY USAGE; ELECTRONIC DEVICES, NAMELY, HANDHELDS FOR EXCHANGING DATA IN ENERGY METERS OR SUBMETERS; ELECTRONIC DEVICES, NAMELY, RADIO FREQUENCY REPEATERS USED IN LONG RANGE COMMUNICATION FOR TRACKING AND MONITORING ENERGY USAGE (U.S. CLS. 21, 23, 26, 36 AND 38).

SN 85-269,321. CLICKSHARE SERVICE CORPORATION, AMHERST, MA. FILED 3-17-2011.

DIGITAL CALLING CARD

THE MARK CONSISTS OF STANDARD CHARACTERS WITHOUT CLAIM TO ANY PARTICULAR FONT, STYLE, SIZE, OR COLOR.

NO CLAIM IS MADE TO THE EXCLUSIVE RIGHT TO USE "DIGITAL", APART FROM THE MARK AS SHOWN.

CLASS 35—ADVERTISING AND BUSINESS

FOR PROVIDING REGISTERED INTERNET USER INFORMATION TO VENDORS AND CONTENT BEARING WEBSITES; TRACKING AND BILLING INTERNET TRANSACTIONS FOR PROCESSING (U.S. CLS. 100, 101 AND 102).

FIRST USE 10-13-1998; IN COMMERCE 10-13-1998.

CLASS 36—INSURANCE AND FINANCIAL

FOR VALIDATING AND AGGREGATING FINANCIAL INTERNET TRANSACTIONS FOR PROCESSING (U.S. CLS. 100, 101 AND 102).

FIRST USE 10-13-1998; IN COMMERCE 10-13-1998.

INGA ERVIN, EXAMINING ATTORNEY

SN 85-269,584. TENDRIL NETWORKS, INC, BOULDER, CA. FILED 3-17-2011.

TENDRIL
The Power is Yours

OWNER OF U.S. REG. NOS. 3,647,155 AND 3,647,156.

CLASS 35—ADVERTISING AND BUSINESS

FOR ASSISTANCE AND CONSULTANCY SERVICES IN THE FIELD OF BUSINESS MANAGEMENT OF COMPANIES IN THE ENERGY SECTOR; ASSISTANCE, ADVISORY SERVICES AND CONSULTANCY WITH REGARD TO BUSINESS PLANNING, BUSINESS ANALYSIS, BUSINESS MANAGEMENT, AND BUSINESS ORGANIZATION RELATING TO MICRO CREDITS, MICRO FINANCE AND ENERGY PRODUCTS; BUSINESS CONSULTING SERVICES FOR THE ELECTRIC ENERGY INDUSTRY; BUSINESS CONSULTING AND ADVISORY SERVICES IN THE FIELD OF ENERGY EFFICIENCY; BUSINESS SERVICES, NAMELY, A NETWORK OF SOLAR CONTRACTORS RECEIVING LEADS AND BIDDING OPPORTUNITIES BY MEANS OF AN ONLINE MARKETPLACE FOR THE PURPOSE OF DEVELOPING INFORMATION TO EVALUATE THE INVESTMENT VALUE OF SOLAR ENERGY FOR A WEB-BASED CONSUMER; BUSINESS VENTURE DEVELOPMENT AND FORMATION CONSULTING SERVICES FOR THE RENEWABLE ENERGY INDUSTRY; CONDUCTING ENERGY AUDITS OF COMMERCIAL AND INSTITUTIONAL FACILITIES FOR THE PURPOSE OF IMPROVING ENERGY EFFICIENCY; CONSULTATION IN THE FIELD OF ENERGY EFFICIENCY; CONSULTING SERVICES IN THE FIELD OF ENERGY USAGE MANAGEMENT AND ENERGY EFFICIENCY; CONSULTING SERVICES IN THE FIELDS OF ENERGY CONSUMPTION AND USAGE CONSERVATION TO IMPROVE ENERGY EFFICIENCY; CONSULTING SERVICES IN THE FIELD OF ENERGY EFFICIENCY FOR COMMERCIAL AND INSTITUTIONAL FACILITIES; ENERGY AUDITING; ENERGY MANAGEMENT SERVICES, NAMELY, PROVIDING A SERVICE THAT ALLOWS CUSTOMERS TO PURCHASE ENERGY, NAMELY, ELECTRICITY, NATURAL GAS AND RENEWABLE ENERGY, AT A FIXED PRICE; ENERGY MANAGEMENT SERVICES, NAMELY, PROVIDING A SERVICE THAT ALLOWS CUSTOMERS TO PURCHASE ENERGY FROM VARIOUS ENERGY PROVIDERS; ENERGY PRICE COMPARISON SERVICES; ENERGY USAGE MANAGEMENT (U.S. CLS. 100, 101 AND 102).

FIRST USE 2-20-2010; IN COMMERCE 3-23-2010.

JIM RINGLE, EXAMINING ATTORNEY

SN 85-269,688. FAIRWAY GROUP ACQUISITION COMPANY, NEW YORK, NY. FILED 3-17-2011.



OWNER OF U.S. REG. NOS. 3,545,835, 3,641,831 AND OTHERS.

NO CLAIM IS MADE TO THE EXCLUSIVE RIGHT TO USE "WINES & SPIRITS", APART FROM THE MARK AS SHOWN.

THE MARK CONSISTS OF THE REPRESENTATION OF A CORKSCREW, WITH THE WORD "FAIRWAY" UNDERLINED BY A THICK CURVED BAND, ALL INSIDE THE CORKSCREW; UNDERNEATH THE CORKSCREW ARE THE WORDS "WINES & SPIRITS" WITH THE SCREW FROM THE CORKSCREW FORMING THE "I" IN THE WORD "WINES" AND THE FIRST "I" IN THE WORD "SPIRITS", ALL ENCASED IN A SQUARE.

CLASS 35—ADVERTISING AND BUSINESS

FOR ONLINE RETAIL STORE SERVICES FEATURING WINES AND SPIRITS (U.S. CLS. 100, 101 AND 102). FIRST USE 12-15-2010; IN COMMERCE 12-15-2010.

CLASS 43—HOTEL AND RESTAURANT SERVICES

FOR CATERING SERVICES (U.S. CLS. 100 AND 101). FIRST USE 3-2-2011; IN COMMERCE 3-2-2011. CARYN GLASSER, EXAMINING ATTORNEY

SN 85-269,975. KANG, PAUL H., DBA ISLAND VINTAGE COFFEE, HONOLULU, HI. FILED 3-17-2011.

ISLAND VINTAGE COFFEE

THE MARK CONSISTS OF STANDARD CHARACTERS WITHOUT CLAIM TO ANY PARTICULAR FONT, STYLE, SIZE, OR COLOR.

NO CLAIM IS MADE TO THE EXCLUSIVE RIGHT TO USE "COFFEE", APART FROM THE MARK AS SHOWN.

CLASS 30—STAPLE FOODS

FOR COFFEE; COFFEE; COFFEE AND ARTIFICIAL COFFEE; COFFEE AND COFFEE SUBSTITUTES; COFFEE AND TEA; COFFEE BASED BEVERAGES; COFFEE BEANS; COFFEE BEVERAGES WITH MILK; COFFEE ESSENCES; COFFEE EXTRACTS; COFFEE FLAVORED SYRUP USED IN MAKING FOOD BEVERAGES; COFFEE-BASED BEVERAGE CONTAINING MILK; COFFEE-BASED BEVERAGES; GROUND COFFEE BEANS; ICED COFFEE; INSTANT COFFEE; PREPARED COFFEE AND COFFEE-BASED BEVERAGES; ROASTED COFFEE BEANS; UNROASTED COFFEE (U.S. CL. 46).

FIRST USE 6-30-2000; IN COMMERCE 6-30-2000.

CLASS 43—HOTEL AND RESTAURANT SERVICES

FOR COFFEE AND JUICE BAR SERVICES; COFFEE BARS; COFFEE SHOPS; COFFEE SUPPLY SERVICES FOR OFFICES; COFFEE-HOUSE AND SNACK-BAR SERVICES; OFFICE COFFEE SUPPLY SERVICES (U.S. CLS. 100 AND 101).

FIRST USE 3-1-2008; IN COMMERCE 3-1-2008. GIANCARLO CASTRO, EXAMINING ATTORNEY

SN 85-270,311. HEYLEN, JAN, CLEARWATER, FL. FILED 3-18-2011.

HEYLEN VIM SPORTS NUTRITION

THE MARK CONSISTS OF STANDARD CHARACTERS WITHOUT CLAIM TO ANY PARTICULAR FONT, STYLE, SIZE, OR COLOR.

NO CLAIM IS MADE TO THE EXCLUSIVE RIGHT TO USE "SPORTS NUTRITION", APART FROM THE MARK AS SHOWN.

CLASS 5—PHARMACEUTICALS

FOR PROTEIN SUPPLEMENTS; NUTRITIONAL SUPPLEMENTS; DIETARY SUPPLEMENTS; VITAMINS; LIQUID AMINO ACIDS FOR NUTRITIONAL PURPOSES; ENERGY SHAKE MIXES FOR USE AS A MEAL SUBSTITUTE; FOOD SUPPLEMENTS; MEAL REPLACEMENT BARS; MEAL REPLACEMENT POWDERS; MEAL REPLACEMENT SHAKES; MEAL REPLACEMENT DRINKS; POWDERED NUTRITIONAL SUPPLEMENT DRINK MIX AND CONCENTRATE; NUTRITIONAL ENERGY BARS FOR USE AS A MEAL SUBSTITUTE (U.S. CLS. 6, 18, 44, 46, 51 AND 52).

CLASS 32—LIGHT BEVERAGES

FOR CONCENTRATES AND POWDERS USED IN THE PREPARATION OF ENERGY DRINKS; ENERGY DRINKS; SPORT DRINKS (U.S. CLS. 45, 46 AND 48). GILBERT SWIFT, EXAMINING ATTORNEY

SN 85-270,313. HEYLEN, JAN, CLEARWATER, FL. FILED 3-18-2011.



NO CLAIM IS MADE TO THE EXCLUSIVE RIGHT TO USE "SPORTS NUTRITION", APART FROM THE MARK AS SHOWN.

THE COLOR(S) BLACK AND BLUE IS/ARE CLAIMED AS A FEATURE OF THE MARK.

THE MARK CONSISTS OF THE LITERAL ELEMENTS "VIM HEYLEN SPORTS NUTRITION" WHEREIN THE WORD "VIM" IS IN BLUE AND BLACK COLOR WITH THE DOT OF THE LETTER "I" DEPICTING A POWER BUTTON ICON. THE WORDS "HEYLEN SPORTS NUTRITION" ARE PLACED BELOW THE WORD "VIM" WHEREIN THE WORDS "HEYLEN NUTRITION" ARE IN BLACK COLOR AND "SPORTS" IS IN BLUE COLOR AS SHOWN IN THE MARK.

CLASS 5—PHARMACEUTICALS

FOR PROTEIN SUPPLEMENTS; NUTRITIONAL SUPPLEMENTS; DIETARY SUPPLEMENTS; VITAMINS; LIQUID AMINO ACIDS FOR NUTRITIONAL PURPOSES; ENERGY SHAKE MIXES FOR USE AS A MEAL SUBSTITUTE; FOOD SUPPLEMENTS; MEAL REPLACEMENT BARS; MEAL REPLACEMENT POWDERS; MEAL REPLACEMENT SHAKES; MEAL REPLACEMENT DRINKS; POWDERED NUTRITIONAL SUPPLEMENT DRINK MIX AND CONCENTRATE; NUTRITIONAL ENERGY BARS FOR USE AS A MEAL SUBSTITUTE (U.S. CLS. 6, 18, 44, 46, 51 AND 52).

CLASS 32—LIGHT BEVERAGES

FOR CONCENTRATES AND POWDERS USED IN THE PREPARATION OF ENERGY DRINKS; ENERGY DRINKS; SPORT DRINKS (U.S. CLS. 45, 46 AND 48).
GILBERT SWIFT, EXAMINING ATTORNEY

SN 85-270,393, KANG, PAUL H., DBA ISLAND VINTAGE COFFEE, HONOLULU, HI. FILED 3-18-2011.



NO CLAIM IS MADE TO THE EXCLUSIVE RIGHT TO USE "COFFEE", APART FROM THE MARK AS SHOWN.

THE COLOR(S) BROWN, GRAY, WHITE, BLACK IS/ARE CLAIMED AS A FEATURE OF THE MARK.

THE MARK CONSISTS OF A GRAY CIRCLE WITH THE WORDS "ISLAND VINTAGE COFFEE" IN WHITE AND BLACK WRITTEN WITHIN THE CIRCLE. THE CIRCLE IS OUTLINED WITH GRAY LEAVES. IN THE CENTER OF THE CIRCLE IS A WHITE MAN WITH A BROWN AND BLACK ARMOR HAT AND BROWN AND BLACK TOP. THE TRIM OF THE HAT IS BROWN AND BLACK. THE MAN IS HOLDING A WHITE AND BROWN CUP OF COFFEE WITH BROWN STEAM.

CLASS 30—STAPLE FOODS

FOR COFFEE; COFFEE; COFFEE AND ARTIFICIAL COFFEE; COFFEE AND COFFEE SUBSTITUTES; COFFEE AND TEA; COFFEE BASED BEVERAGES; COFFEE BEANS; COFFEE BEVERAGES WITH MILK; COFFEE ESSENCES; COFFEE EXTRACTS; COFFEE FLAVORED SYRUP USED IN MAKING FOOD BEVERAGES; COFFEE-BASED BEVERAGE CONTAINING MILK; COFFEE-BASED BEVERAGES; GROUND COFFEE BEANS; ICED COFFEE; INSTANT COFFEE; PREPARED COFFEE AND COFFEE-BASED BEVERAGES; ROASTED COFFEE BEANS; UNROASTED COFFEE (U.S. CL. 46).
FIRST USE 3-1-2008; IN COMMERCE 3-1-2008.

CLASS 43—HOTEL AND RESTAURANT SERVICES

FOR COFFEE AND JUICE BAR SERVICES; COFFEE BARS; COFFEE SHOPS; COFFEE SUPPLY SERVICES FOR OFFICES; COFFEE-HOUSE AND SNACK-BAR SERVICES; OFFICE COFFEE SUPPLY SERVICES (U.S. CLS. 100 AND 101).

FIRST USE 3-1-2008; IN COMMERCE 3-1-2008.
GIANCARLO CASTRO, EXAMINING ATTORNEY

SN 85-270,409, VICKY VINCH, TA DIRTY HIPPIE DESIGNS, LOUISVILLE, KY. FILED 3-18-2011.

Dirty Hippie Designs

THE MARK CONSISTS OF STANDARD CHARACTERS WITHOUT CLAIM TO ANY PARTICULAR FONT, STYLE, SIZE, OR COLOR.

NO CLAIM IS MADE TO THE EXCLUSIVE RIGHT TO USE "DESIGNS", APART FROM THE MARK AS SHOWN.

CLASS 18—LEATHER GOODS

FOR T-SHIRTS FOR DOGS AND CATS (U.S. CLS. 1, 2, 3, 22 AND 41).

CLASS 25—CLOTHING

FOR SHORT-SLEEVED OR LONG-SLEEVED T-SHIRTS; T-SHIRTS; T-SHIRTS FOR BABIES, ADULTS, CHILDREN, WOMEN, MEN, AND TEENS (U.S. CLS. 22 AND 39).

JOHN KELLY, EXAMINING ATTORNEY

SN 85-270,565, IDEA NUOVA, INC., NEW YORK, NY. FILED 3-18-2011.

FLOOR PETS

THE MARK CONSISTS OF STANDARD CHARACTERS WITHOUT CLAIM TO ANY PARTICULAR FONT, STYLE, SIZE, OR COLOR.

NO CLAIM IS MADE TO THE EXCLUSIVE RIGHT TO USE "PETS" FOR INTERNATIONAL CLASS 28, APART FROM THE MARK AS SHOWN.

CLASS 11—ENVIRONMENTAL CONTROL APPARATUS

FOR ELECTRIC LAMPS; ELECTRIC NIGHT LIGHTS; LAMPS (U.S. CLS. 13, 21, 23, 31 AND 34).

CLASS 20—FURNITURE AND ARTICLES NOT OTHERWISE CLASSIFIED

FOR PILLOWS (U.S. CLS. 2, 13, 22, 25, 32 AND 50).

CLASS 24—FABRICS

FOR BED BLANKETS; BED CANOPIES; BED COVERS; BED LINEN; BED SHEETS; BED SKIRTS; BED SPREADS; BED THROWS; CURTAINS (U.S. CLS. 42 AND 50).

CLASS 28—TOYS AND SPORTING GOODS

FOR PLUSH TOYS; STUFFED TOYS (U.S. CLS. 22, 23, 38 AND 50).
DAVID ELTON, EXAMINING ATTORNEY

SN 85-271,244. HOTELS.COM, L.P., DALLAS, TX. FILED 3-18-2011.

SN 85-271,594. AMIN CORPORATION, WEST BLOOMFIELD, MI. AND BUYCROWD, INC., WEST BLOOMFIELD, MI. FILED 3-19-2011.

ZipDeals

THE MARK CONSISTS OF STANDARD CHARACTERS WITHOUT CLAIM TO ANY PARTICULAR FONT, STYLE, SIZE, OR COLOR.

CLASS 35—ADVERTISING AND BUSINESS

FOR CONDUCTING INCENTIVE AWARD PROGRAMS TO PROMOTE THE SALE OF ACCOMMODATIONS, HOTEL AND MOTEL ROOMS OF OTHERS; CONSUMER LOYALTY SERVICES FOR COMMERCIAL, PROMOTIONAL, AND ADVERTISING PURPOSES, NAMELY, ADMINISTRATION OF FREQUENT TRAVELER PROGRAM; CUSTOMER LOYALTY SERVICES AND CUSTOMER CLUB SERVICES, FOR COMMERCIAL, PROMOTIONAL AND/OR ADVERTISING PURPOSES; PROMOTING THE GOODS AND SERVICES OF OTHERS VIA EMAIL (U.S. CLS. 100, 101 AND 102).

CLASS 39—TRANSPORTATION AND STORAGE

FOR TRAVEL AGENCY SERVICES, NAMELY, MAKING RESERVATIONS AND BOOKINGS FOR TRANSPORTATION AND PROVIDING INFORMATION CONCERNING TRAVEL AND PROVIDING TRAVEL INFORMATION OVER COMPUTER NETWORKS, GLOBAL COMMUNICATION NETWORKS AND MOBILE NETWORKS; CUSTOMER SERVICES, NAMELY, PROVIDING CONFIRMATIONS OF BOOKINGS FOR TRANSPORTATION VIA EMAIL (U.S. CLS. 100 AND 105).

CLASS 41—EDUCATION AND ENTERTAINMENT

FOR PROVIDING NEWSLETTERS IN THE FIELD OF TRAVEL VIA E-MAIL (U.S. CLS. 100, 101 AND 107).

CLASS 43—HOTEL AND RESTAURANT SERVICES

FOR TRAVEL AGENCY SERVICES, NAMELY, MAKING RESERVATIONS AND BOOKINGS FOR TEMPORARY ACCOMMODATIONS; PROVIDING TEMPORARY ACCOMMODATION INFORMATION SERVICES; MAKING RESERVATIONS AND BOOKINGS FOR TEMPORARY ACCOMMODATIONS AND PROVIDING ACCOMMODATION INFORMATION OVER COMPUTER NETWORKS, GLOBAL COMPUTER COMMUNICATION NETWORKS AND MOBILE NETWORKS; CUSTOMER SERVICES, NAMELY, PROVIDING CONFIRMATIONS OF BOOKINGS OF TEMPORARY ACCOMMODATIONS VIA EMAIL (U.S. CLS. 100 AND 101).

CYNTHIA SLOAN, EXAMINING ATTORNEY

ViZiB

THE MARK CONSISTS OF STANDARD CHARACTERS WITHOUT CLAIM TO ANY PARTICULAR FONT, STYLE, SIZE, OR COLOR.

CLASS 35—ADVERTISING AND BUSINESS

FOR PROVIDING A SEARCHABLE ONLINE ADVERTISING WEBSITE AND INFORMATIONAL GUIDE FEATURING THE GOODS AND SERVICES OF OTHER VENDORS VIA THE INTERNET IN THE FIELD OF INTERNET AUDIO, INTERNET RADIO, STREAMING VIDEO, INTERNET TV, BROADBAND COMMUNICATIONS DEVICES AND SERVICES, WEB HOSTING SERVICES, WEB DESIGN SERVICES, ECOMMERCE SERVICES, MEDIA SHARING AND STREAMING (U.S. CLS. 100, 101 AND 102).

FIRST USE 1-26-2007; IN COMMERCE 1-26-2007.

CLASS 42—SCIENTIFIC AND COMPUTER SERVICES

FOR PROVIDING A WEBSITE FEATURING TECHNOLOGY THAT ENABLES USERS TO UPLOAD AND SHARE USER-GENERATED MEDIA ON A WIDE VARIETY OF TOPICS AND SUBJECTS (U.S. CLS. 100 AND 101).

EDWARD FENNESSY, EXAMINING ATTORNEY

SN 85-271,651. ENERGYGUARD ATLANTIC, DBA ENERCO, NEW YORK, NY. FILED 3-20-2011.

ener.co

THE MARK CONSISTS OF STANDARD CHARACTERS WITHOUT CLAIM TO ANY PARTICULAR FONT, STYLE, SIZE, OR COLOR.

CLASS 1—CHEMICALS

FOR CHEMICAL SOLUTIONS IN THE NATURE OF MULTIMETAL CORROSION AND SCALE INHIBITOR TREATMENTS FOR HYDRONIC HEATING AND COOLING SYSTEMS (U.S. CLS. 1, 5, 6, 10, 26 AND 46).

CLASS 2—PAINTS

FOR COATING COMPOSITIONS IN THE NATURE OF PAINT FOR INDUSTRIAL APPLICATIONS; COATINGS IN THE NATURE OF THERMALLY CONDUCTIVE NANO-COMPOSITE DESIGNED TO ENHANCE COOLING PERFORMANCE AND CORROSION PROTECTION OF HEAT EXCHANGE EQUIPMENT (U.S. CLS. 6, 11 AND 16).

CLASS 5—PHARMACEUTICALS

FOR ANTIMICROBIAL COATINGS TO TREAT THE GROWTH OF MOLD, MILDEW, BACTERIA AND FUNGUS ON VARIOUS SURFACES (U.S. CLS. 6, 18, 44, 46, 51 AND 52).

CLASS 37—CONSTRUCTION AND REPAIR

FOR APPLICATION OF COATINGS FOR OTHERS, NAMELY, APPLYING ANTI-CORROSIVE COATINGS FOR THE PROTECTION OF HEAT EXCHANGE EQUIPMENT; APPLICATION OF PROTECTIVE COATINGS; TECHNICAL SUPPORT SERVICES, NAMELY, TECHNICAL CONSULTATION IN THE FIELD OF APPLICATION OF SPRAY-ON INSULATION AND PROTECTIVE COATINGS (U.S. CLS. 100, 103 AND 106).

KAREN SEVERSON, EXAMINING ATTORNEY

SN 85-271,710. THE JON DAVIS COMPANIES INC., DALLAS, TX. FILED 3-20-2011.

The Petraeus Strategy

THE MARK CONSISTS OF STANDARD CHARACTERS WITHOUT CLAIM TO ANY PARTICULAR FONT, STYLE, SIZE, OR COLOR.

NO CLAIM IS MADE TO THE EXCLUSIVE RIGHT TO USE "STRATEGY", APART FROM THE MARK AS SHOWN.

CLASS 35—ADVERTISING AND BUSINESS

FOR BUSINESS MANAGEMENT CONSULTING WITH RELATION TO STRATEGY, FINANCING, MARKET-ING, PRODUCTION, PERSONNEL AND SALES MATTERS FOR THE HVAC INDUSTRY. PROFESSIONAL STAFFING AND RECRUITING SERVICES FOR THE HVAC INDUSTRY (U.S. CLS. 100, 101 AND 102).

FIRST USE 11-1-2010; IN COMMERCE 11-1-2010.

CLASS 41—EDUCATION AND ENTERTAINMENT

FOR EDUCATIONAL SERVICES, NAMELY, CONDUCTING SEMINARS, CONFERENCES, WORKSHOPS AND WEBINARS IN THE FIELD OF HVAC SALES AND SERVICES AND DISTRIBUTION OF TRAINING MATERIAL IN CONNECTION THEREWITH (U.S. CLS. 100, 101 AND 107).

FIRST USE 11-1-2010; IN COMMERCE 11-1-2010.

LINDA POWELL, EXAMINING ATTORNEY

SN 85-271,957. KASSIM, KHALID R, TAMPA, FL. FILED 3-21-2011.



THE MARK CONSISTS OF "TIPNTAG" ALL IN LOWER-CASE LETTERS. A LEMUR WITH A RAISED TAIL SITTING ON THE LETTER "G" AND AN APOSTROPHE BETWEEN THE LETTER "N" AND THE LETTER "T" IN THE WORD "TAG".

CLASS 35—ADVERTISING AND BUSINESS

FOR PROVIDING A CONSUMER WEBSITE WHERE USERS CAN POST CONSUMER INFORMATION IN THE NATURE OF REVIEWS AND RECOMMENDATIONS ON A WIDE VARIETY OF PRODUCTS, SERVICES AND ACTIVITIES (U.S. CLS. 100, 101 AND 102).

CLASS 39—TRANSPORTATION AND STORAGE

FOR PROVIDING A QUESTION AND ANSWER WEBSITE WHERE USERS CAN POST GEOGRAPHIC INFORMATION (U.S. CLS. 100 AND 105).

CAROLYN CATALDO, EXAMINING ATTORNEY

SN 85-272,404. SPEEDWAY MOTORS, INC., LINCOLN, NE. FILED 3-21-2011.

BLUE DIAMOND CLASSICS

THE MARK CONSISTS OF STANDARD CHARACTERS WITHOUT CLAIM TO ANY PARTICULAR FONT, STYLE, SIZE, OR COLOR.

OWNER OF U.S. REG. NOS. 2,542,408 AND 2,542,437.

NO CLAIM IS MADE TO THE EXCLUSIVE RIGHT TO USE "CLASSICS", APART FROM THE MARK AS SHOWN.

CLASS 28—TOYS AND SPORTING GOODS

FOR TOY VEHICLES, NAMELY, REPRODUCTION PEDAL CARS AND PARTS (U.S. CLS. 22, 23, 38 AND 50).

FIRST USE 7-0-1985; IN COMMERCE 7-0-1985.

CLASS 35—ADVERTISING AND BUSINESS

FOR MAIL ORDER CATALOG SERVICES FOR REPLACEMENT AND REPRODUCTION PARTS, GRAPHICS AND ACCESSORIES FOR PEDAL CARS (U.S. CLS. 100, 101 AND 102).

FIRST USE 7-0-1985; IN COMMERCE 7-0-1985.

ANGELA M. MICHELI, EXAMINING ATTORNEY

SN 85-272,482. WARREN, JAMES L., HAYS, KS. FILED 3-21-2011.

TURBBIT

THE MARK CONSISTS OF STANDARD CHARACTERS WITHOUT CLAIM TO ANY PARTICULAR FONT, STYLE, SIZE, OR COLOR.

CLASS 16—PAPER GOODS AND PRINTED MATTER

FOR SERIES OF BOOKS FOR CHILDREN; DECALS, STICKERS, STICKER ALBUMS, POSTERS, COLORING BOOKS, CHILDREN'S ACTIVITY BOOKS, BOOK-MARKS, AND GREETING CARDS (U.S. CLS. 2, 5, 22, 23, 29, 37, 38 AND 50).

CLASS 25—CLOTHING

FOR CLOTHING, NAMELY, SWEAT SHIRTS, T-SHIRTS, SHIRTS, SLEEPWEAR (U.S. CLS. 22 AND 39).

CLASS 28—TOYS AND SPORTING GOODS

FOR PLUSH TOYS, STUFFED TOY ANIMALS, FABRIC TOYS, BOARD GAMES, TOY FIGURES; TOY ACTION FIGURES AND ACCESSORIES THEREFOR; SOFT SCULPTURE TOYS, AND STUFFED TOYS; TOY JEWELRY (U.S. CLS. 22, 23, 38 AND 50).

EUGENIA MARTIN, EXAMINING ATTORNEY

SN 85-272,507. WOODRUFF-SAWYER & CO., SAN FRANCISCO, CA. FILED 3-21-2011.

CLASS 35—ADVERTISING AND BUSINESS

FOR PROVIDING INFORMATION ABOUT HUMAN RESOURCES AND EMPLOYMENT POLICIES (U.S. CLS. 100, 101 AND 102).

FIRST USE 4-20-2010; IN COMMERCE 4-20-2010.

CLASS 36—INSURANCE AND FINANCIAL

FOR ADMINISTRATION OF EMPLOYEE BENEFIT PLANS CONCERNING INSURANCE AND FINANCE; PROVIDING INFORMATION ABOUT EMPLOYEE BENEFITS PLANS CONCERNING INSURANCE AND FINANCE IN GENERAL AS WELL AS EMPLOYEES' OWN SPECIFIC BENEFITS WITH THEIR COMPANY (U.S. CLS. 100, 101 AND 102).

FIRST USE 4-20-2010; IN COMMERCE 4-20-2010.

KARANENDRA S. CHHINA, EXAMINING ATTORNEY



SN 85-272,547. CROSS MEDIAPRODUCTIONS, LLC, NEW YORK, NY. FILED 3-21-2011.

NO CLAIM IS MADE TO THE EXCLUSIVE RIGHT TO USE "CO.", APART FROM THE MARK AS SHOWN.

THE MARK CONSISTS OF THE WORD "BENEFIT-STREAM" PLUS WAVY LINES WITH "BY WOODRUFF-SAWYER & CO." AT THE BOTTOM RIGHT OF THE MARK

CLASS 35—ADVERTISING AND BUSINESS

FOR PROVIDING INFORMATION ABOUT HUMAN RESOURCES AND EMPLOYMENT POLICIES (U.S. CLS. 100, 101 AND 102).

FIRST USE 4-20-2010; IN COMMERCE 4-20-2010.

CLASS 36—INSURANCE AND FINANCIAL

FOR ADMINISTRATION OF EMPLOYEE BENEFIT PLANS CONCERNING INSURANCE AND FINANCE; PROVIDING INFORMATION ABOUT EMPLOYEE BENEFITS PLANS CONCERNING INSURANCE AND FINANCE IN GENERAL AS WELL AS EMPLOYEES' OWN SPECIFIC BENEFITS WITH THEIR COMPANY (U.S. CLS. 100, 101 AND 102).

FIRST USE 4-20-2010; IN COMMERCE 4-20-2010.

KARANENDRA S. CHHINA, EXAMINING ATTORNEY

SN 85-272,513. WOODRUFF-SAWYER & CO., SAN FRANCISCO, CA. FILED 3-21-2011.

BENEFITSTREAM

THE MARK CONSISTS OF STANDARD CHARACTERS WITHOUT CLAIM TO ANY PARTICULAR FONT, STYLE, SIZE, OR COLOR.

THE INDIE SCENE

THE MARK CONSISTS OF STANDARD CHARACTERS WITHOUT CLAIM TO ANY PARTICULAR FONT, STYLE, SIZE, OR COLOR.

OWNER OF U.S. REG. NO. 3,959,564.

CLASS 35—ADVERTISING AND BUSINESS

FOR PROVIDING HOME SHOPPING SERVICES IN THE FIELD OF GENERAL MERCHANDISE BY MEANS OF TELEVISION AND THE INTERNET; RETAIL STORE SERVICES AVAILABLE THROUGH INTERACTIVE TELEVISION FEATURING GENERAL MERCHANDISE; RETAIL SHOPPING SERVICES IN THE FIELD OF GENERAL MERCHANDISE BY MEANS OF INTERNET, MOBILE PHONE AND PORTABLE AND HAND-HELD DIGITAL AND ELECTRONIC DEVICES; ON-LINE RETAIL STORE SERVICES FEATURING GENERAL MERCHANDISE (U.S. CLS. 100, 101 AND 102).

CLASS 41—EDUCATION AND ENTERTAINMENT

FOR ENTERTAINMENT IN THE NATURE OF ONGOING PROGRAMS IN THE FIELDS OF FASHION, CLOTHING, FASHION ACCESSORIES, FILM, MUSIC AND THE ARTS, ACCESSIBLE BY TELEVISION, THE INTERNET, AND DIGITAL AND WIRELESS NETWORKS, AND PROVIDING AN ENTERTAINMENT INTERNET WEBSITE RELATED TO ONGOING PROGRAMS; ENTERTAINMENT SERVICES, NAMELY, PRODUCING AND DISTRIBUTING PROGRAMS FOR BROADCAST VIA TELEVISION, THE INTERNET AND DIGITAL AND WIRELESS NETWORKS (U.S. CLS. 100, 101 AND 107).

TINA MAI, EXAMINING ATTORNEY

SN 85-272,626. MENTOR WORLDWIDE LLC, SANTA BARBARA, CA. FILED 3-21-2011.

SN 85-272,699. FUNTANK LLC, NEW YORK, NY. FILED 3-21-2011.



THE MARK CONSISTS OF THE STYLIZED WORDING "LEAD" ON TOP OF THE SMALLER PHRASE "LEADERSHIP, EXPERIENCE AND DEVELOPMENT IN BREAST AUGMENTATION" ALL CONTAINED IN A RECTANGLE.

CLASS 41—EDUCATION AND ENTERTAINMENT

FOR EDUCATION, NAMELY, CONDUCTING EDUCATIONAL PROGRAMS IN THE FIELD OF BREAST AUGMENTATION AND BREAST RECONSTRUCTION (U.S. CLS. 100, 101 AND 107).

CLASS 44—MEDICAL, BEAUTY AND AGRICULTURAL SERVICES

FOR CONSULTING IN THE FIELD OF BREAST AUGMENTATION AND BREAST RECONSTRUCTION (U.S. CLS. 100 AND 101).

JOHN SCHUYLER YARD, EXAMINING ATTORNEY

SN 85-272,651. COMPONENT HARDWARE GROUP, INC., LAKEWOOD, NJ. FILED 3-21-2011.



NO CLAIM IS MADE TO THE EXCLUSIVE RIGHT TO USE "HARDWARE", APART FROM THE MARK AS SHOWN.

THE COLOR(S) BLUE, YELLOW AND GRAY IS/ARE CLAIMED AS A FEATURE OF THE MARK.

THE MARK CONSISTS OF THE WORDS "COMPONENT HARDWARE" AND AN EXPLODED PERSPECTIVE VIEW OF A BOX AND LID. THE COLOR BLUE FOR THE ELEMENT "COMPONENT" AND THE PICTORIAL ILLUSTRATION OF A LID, YELLOW FOR THE PICTORIAL ILLUSTRATION OF THE INTERIOR OF A BOX AND GRAY FOR THE ELEMENT "HARDWARE" AND THE PICTORIAL ILLUSTRATION OF THE EXTERIOR OF THE BOX IS CLAIMED AS A FEATURE OF THE MARK.

CLASS 3—COSMETICS AND CLEANING PREPARATIONS

FOR PREPARATIONS FOR CLEANING AND PROTECTING STAINLESS STEEL SURFACES (U.S. CLS. 1, 4, 6, 50, 51 AND 52).

FIRST USE 2-10-2011; IN COMMERCE 2-10-2011.

CLASS 17—RUBBER GOODS

FOR SILICONE SEALANT (U.S. CLS. 1, 5, 12, 13, 35 AND 50).

FIRST USE 2-2-2011; IN COMMERCE 2-2-2011.
KHANH LE, EXAMINING ATTORNEY

electric-box

THE MARK CONSISTS OF THE WORDING "ELECTRIC BOX" WITH A CIRCLE AND HORIZONTAL BAND PLACED INSIDE THE LETTERS "C" AND "B" AND A CIRCLE PLACED INSIDE THE LETTER "O".

CLASS 9—ELECTRICAL AND SCIENTIFIC APPARATUS

FOR COMPUTER GAME PROGRAMS; COMPUTER GAME SOFTWARE; COMPUTER GAME SOFTWARE DOWNLOADABLE FROM A GLOBAL COMPUTER NETWORK; COMPUTER GAME SOFTWARE FOR USE ON MOBILE AND CELLULAR PHONES AND MOBILE DEVICES; COMPUTER PROGRAMS FOR VIDEO AND COMPUTER GAMES (U.S. CLS. 21, 23, 26, 36 AND 38).

FIRST USE 1-19-2009; IN COMMERCE 1-19-2009.

CLASS 41—EDUCATION AND ENTERTAINMENT

FOR ONLINE COMPUTER GAMES (U.S. CLS. 100, 101 AND 107).

FIRST USE 1-19-2009; IN COMMERCE 1-19-2009.
LESLIE RICHARDS, EXAMINING ATTORNEY

SN 85-273,014. CRYO-CELL INTERNATIONAL, INC., OLDSMAR, FL. FILED 3-22-2011.

INNOVATIVE STEM CELL SOLUTIONS

THE MARK CONSISTS OF STANDARD CHARACTERS WITHOUT CLAIM TO ANY PARTICULAR FONT, STYLE, SIZE, OR COLOR.

NO CLAIM IS MADE TO THE EXCLUSIVE RIGHT TO USE "STEM CELL SOLUTIONS", APART FROM THE MARK AS SHOWN.

CLASS 39—TRANSPORTATION AND STORAGE

FOR STORAGE OF HUMAN CELLS, BLOOD, AND TISSUE FOR THERAPEUTIC, BIOTECHNOLOGICAL, COSMETIC, PHARMACEUTICAL AND MEDICAL USE (U.S. CLS. 100 AND 105).

CLASS 44—MEDICAL, BEAUTY AND AGRICULTURAL SERVICES

FOR HUMAN BLOOD, CELL, AND TISSUE BANKING SERVICES; COLLECTION AND PRESERVATION OF HUMAN BLOOD, CELLS AND TISSUE (U.S. CLS. 100 AND 101).

JAMES GRIFFIN, EXAMINING ATTORNEY

SN 85-273,023. BASE VELOCITY LLC, NORMAN, OK. FILED 3-22-2011.

SN 85-273,051. CRYO-CELL INTERNATIONAL, INC., OLD-SMAR, FL. FILED 3-22-2011.

RADARSCOPE

BANKING ON MIRACLES

THE MARK CONSISTS OF STANDARD CHARACTERS WITHOUT CLAIM TO ANY PARTICULAR FONT, STYLE, SIZE, OR COLOR.

THE MARK CONSISTS OF STANDARD CHARACTERS WITHOUT CLAIM TO ANY PARTICULAR FONT, STYLE, SIZE, OR COLOR.

CLASS 9—ELECTRICAL AND SCIENTIFIC APPARATUS

CLASS 39—TRANSPORTATION AND STORAGE

FOR DOWNLOADABLE SOFTWARE FOR DISPLAYING WEATHER INFORMATION VIA THE INTERNET AND MOBILE DEVICES (U.S. CLS. 21, 23, 26, 36 AND 38). FIRST USE 8-31-2008; IN COMMERCE 8-31-2008.

FOR STORAGE OF HUMAN CELLS, BLOOD, AND TISSUE FOR THERAPEUTIC, BIOTECHNOLOGICAL, COSMETIC, PHARMACEUTICAL AND MEDICAL USE (U.S. CLS. 100 AND 105).

CLASS 42—SCIENTIFIC AND COMPUTER SERVICES

CLASS 44—MEDICAL, BEAUTY AND AGRICULTURAL SERVICES

FOR PROVIDING INFORMATION ABOUT WEATHER VIA THE INTERNET AND MOBILE DEVICES (U.S. CLS. 100 AND 101). FIRST USE 8-31-2008; IN COMMERCE 8-31-2008. ELIZABETH HUGHITT, EXAMINING ATTORNEY

FOR HUMAN BLOOD, CELL, AND TISSUE BANKING SERVICES; COLLECTION AND PRESERVATION OF HUMAN BLOOD, CELLS AND TISSUE (U.S. CLS. 100 AND 101). JAMES GRIFFIN, EXAMINING ATTORNEY

SN 85-273,034. CRYO-CELL INTERNATIONAL, INC., OLD-SMAR, FL. FILED 3-22-2011.

SN 85-273,078. CRYO-CELL INTERNATIONAL, INC., OLD-SMAR, FL. FILED 3-22-2011.

ALMACENANDO MILAGROS

MIRACLES IN THE MAKING

THE MARK CONSISTS OF STANDARD CHARACTERS WITHOUT CLAIM TO ANY PARTICULAR FONT, STYLE, SIZE, OR COLOR.

THE MARK CONSISTS OF STANDARD CHARACTERS WITHOUT CLAIM TO ANY PARTICULAR FONT, STYLE, SIZE, OR COLOR.

CLASS 39—TRANSPORTATION AND STORAGE

CLASS 39—TRANSPORTATION AND STORAGE

FOR STORAGE OF HUMAN CELLS, BLOOD, AND TISSUE FOR THERAPEUTIC, BIOTECHNOLOGICAL, COSMETIC, PHARMACEUTICAL AND MEDICAL USE (U.S. CLS. 100 AND 105).

FOR STORAGE OF HUMAN CELLS, BLOOD, AND TISSUE FOR THERAPEUTIC, BIOTECHNOLOGICAL, COSMETIC, PHARMACEUTICAL AND MEDICAL USE (U.S. CLS. 100 AND 105).

CLASS 44—MEDICAL, BEAUTY AND AGRICULTURAL SERVICES

CLASS 44—MEDICAL, BEAUTY AND AGRICULTURAL SERVICES

FOR HUMAN BLOOD, CELL, AND TISSUE BANKING SERVICES; COLLECTION AND PRESERVATION OF HUMAN BLOOD, CELLS AND TISSUE (U.S. CLS. 100 AND 101). JAMES GRIFFIN, EXAMINING ATTORNEY

FOR HUMAN BLOOD, CELL, AND TISSUE BANKING SERVICES; COLLECTION AND PRESERVATION OF HUMAN BLOOD, CELLS AND TISSUE (U.S. CLS. 100 AND 101). JAMES GRIFFIN, EXAMINING ATTORNEY

SN 85-273,139. CRYO-CELL INTERNATIONAL, INC., OLD-SMAR, FL. FILED 3-22-2011.

SN 85-273,158. CRYO-CELL INTERNATIONAL, INC., OLD-SMAR, FL. FILED 3-22-2011.

**PROTECT BABY, PROTECT MOM,
PROTECT FAMILY**

THE MARK CONSISTS OF STANDARD CHARACTERS WITHOUT CLAIM TO ANY PARTICULAR FONT, STYLE, SIZE, OR COLOR.

CLASS 39—TRANSPORTATION AND STORAGE

FOR STORAGE OF HUMAN CELLS, BLOOD, AND TISSUE FOR THERAPEUTIC, BIOTECHNOLOGICAL, COSMETIC, PHARMACEUTICAL AND MEDICAL USE (U.S. CLS. 100 AND 105).

CLASS 44—MEDICAL, BEAUTY AND AGRICULTURAL SERVICES

FOR HUMAN BLOOD, CELL, AND TISSUE BANKING SERVICES; COLLECTION AND PRESERVATION OF HUMAN BLOOD, CELLS AND TISSUE (U.S. CLS. 100 AND 101).

JAMES GRIFFIN, EXAMINING ATTORNEY

SN 85-273,157. THE SPORTSMAN CHANNEL, INC., NEW BERLIN, WI. FILED 3-22-2011.

SPORTSMAN CHANNEL

THE MARK CONSISTS OF STANDARD CHARACTERS WITHOUT CLAIM TO ANY PARTICULAR FONT, STYLE, SIZE, OR COLOR.

NO CLAIM IS MADE TO THE EXCLUSIVE RIGHT TO USE "CHANNEL", APART FROM THE MARK AS SHOWN.

CLASS 9—ELECTRICAL AND SCIENTIFIC APPARATUS

FOR PRE-RECORDED VIDEO RECORDINGS FEATURING HUNTING, SHOOTING, FISHING, FIREARMS AND OUTDOOR ACTIVITIES (U.S. CLS. 21, 23, 26, 36 AND 38).

FIRST USE 4-7-2003; IN COMMERCE 4-7-2003.

CLASS 41—EDUCATION AND ENTERTAINMENT

FOR PRODUCTION AND DISTRIBUTION OF VIDEO RECORDINGS AND TELEVISION PROGRAMS FEATURING HUNTING, SHOOTING, FISHING, FIREARMS AND OUTDOOR ACTIVITIES; ENTERTAINMENT IN THE NATURE OF ON-GOING TELEVISION PROGRAMS IN THE FIELDS OF HUNTING, SHOOTING, FISHING, FIREARMS AND OUTDOOR ACTIVITIES; ENTERTAINMENT SERVICES, NAMELY, PROVIDING ON-GOING VIDEO PROGRAMS AND INFORMATION IN THE FIELDS OF HUNTING, SHOOTING, FISHING, FIREARMS AND OUTDOOR ACTIVITIES VIA A GLOBAL COMPUTER NETWORK (U.S. CLS. 100, 101 AND 107).

FIRST USE 4-7-2003; IN COMMERCE 4-7-2003.
MORGAN WYNNE, EXAMINING ATTORNEY

**FAMILY HEALTHCARE
PROTECTION PORTFOLIO**

THE MARK CONSISTS OF STANDARD CHARACTERS WITHOUT CLAIM TO ANY PARTICULAR FONT, STYLE, SIZE, OR COLOR.

NO CLAIM IS MADE TO THE EXCLUSIVE RIGHT TO USE "FAMILY HEALTHCARE", APART FROM THE MARK AS SHOWN.

CLASS 39—TRANSPORTATION AND STORAGE

FOR STORAGE OF HUMAN CELLS, BLOOD, AND TISSUE FOR THERAPEUTIC, BIOTECHNOLOGICAL, COSMETIC, PHARMACEUTICAL AND MEDICAL USE (U.S. CLS. 100 AND 105).

CLASS 44—MEDICAL, BEAUTY AND AGRICULTURAL SERVICES

FOR HUMAN BLOOD, CELL, AND TISSUE BANKING SERVICES; COLLECTION AND PRESERVATION OF HUMAN BLOOD, CELLS AND TISSUE (U.S. CLS. 100 AND 101).

JAMES GRIFFIN, EXAMINING ATTORNEY

SN 85-273,195. MACIVER, SANDRA LEE, AKA SANDY MACIVER, ABINGDON, MD. FILED 3-22-2011.



THE MARK CONSISTS OF A STYLIZED KNOTTED BANDANA HEAD CHARACTER WITH DOTS FOR EYES AND WHICH SHOWS LINES ABOVE THE BANDANNA TO CONVEY THAT THE CHARACTER IS SWEATING; THE BANDANNA INCLUDES RANDOM SPLOTCHES INTENDED TO CONVEY SPLATTERED MUD.

CLASS 14—JEWELRY

FOR JEWELRY STICKPINS; JEWELRY, NAMELY, BRACELETS, WRISTBANDS AND NECKLACES THAT ALSO PROVIDES NOTIFICATION TO THE WEARER OF A PENDING MEDICAL RELATED TASK; LAPEL PINS; PET JEWELRY; PLASTIC BRACELETS IN THE NATURE OF JEWELRY; WOMEN'S JEWELRY (U.S. CLS. 2, 27, 28 AND 50).

CLASS 21—HOUSEWARES AND GLASS

FOR EMPTY WATER BOTTLES FOR BICYCLES (U.S. CLS. 2, 13, 23, 29, 30, 33, 40 AND 50).

CLASS 25—CLOTHING

FOR APPAREL FOR DANCERS, NAMELY, TEE SHIRTS, SWEATSHIRTS, PANTS, LEGGINGS, SHORTS AND JACKETS; ATHLETIC APPAREL, NAMELY, SHIRTS, PANTS, JACKETS, FOOTWEAR, HATS AND CAPS, ATHLETIC UNIFORMS; CHILDREN'S AND INFANT'S APPAREL, NAMELY, JUMPERS, OVERALL SLEEPWEAR, PAJAMAS, ROMPERS AND ONE-PIECE GARMENTS; GLOVES FOR APPAREL (U.S. CLS. 22 AND 39).

HEATHER THOMPSON, EXAMINING ATTORNEY

SN 85-273,198. THE SPORTSMAN CHANNEL, INC., NEW BERLIN, WI. FILED 3-22-2011.



NO CLAIM IS MADE TO THE EXCLUSIVE RIGHT TO USE "CHANNEL", APART FROM THE MARK AS SHOWN. THE MARK CONSISTS OF THE WORDS "SPORTSMAN CHANNEL" AND 3 CIRCLES TO THE LEFT OF "HD". EACH CIRCLE CONTAINS A SECOND INTERIOR CIRCLE AND A DESIGN ELEMENT. THE FIRST IS THE OUTLINE OF AN ANTLER, THE SECOND A STYLIZED TARGET AND THE THIRD A SWIMMING FISH.

CLASS 9—ELECTRICAL AND SCIENTIFIC APPARATUS

FOR PRE-RECORDED VIDEO RECORDINGS FEATURING HUNTING, SHOOTING, FISHING, FIREARMS AND OUTDOOR ACTIVITIES (U.S. CLS. 21, 23, 26, 36 AND 38).

FIRST USE 9-15-2009; IN COMMERCE 9-15-2009.

CLASS 41—EDUCATION AND ENTERTAINMENT

FOR PRODUCTION AND DISTRIBUTION OF VIDEO RECORDINGS AND TELEVISION PROGRAMS FEATURING HUNTING, SHOOTING, FISHING, FIREARMS AND OUTDOOR ACTIVITIES; ENTERTAINMENT IN THE NATURE OF ON-GOING TELEVISION PROGRAMS IN THE FIELDS OF HUNTING, SHOOTING, FISHING, FIREARMS AND OUTDOOR ACTIVITIES; ENTERTAINMENT SERVICES, NAMELY, PROVIDING ON-GOING VIDEO PROGRAMS AND INFORMATION IN THE FIELDS OF HUNTING, SHOOTING, FISHING, FIREARMS AND OUTDOOR ACTIVITIES VIA A GLOBAL COMPUTER NETWORK (U.S. CLS. 100, 101 AND 107).

FIRST USE 6-29-2009; IN COMMERCE 6-29-2009.
MORGAN WYNNE, EXAMINING ATTORNEY

SN 85-273,237. MOGGLE, INC., PHILADELPHIA, PA. FILED 3-22-2011.



NO CLAIM IS MADE TO THE EXCLUSIVE RIGHT TO USE "VIRTUAL", APART FROM THE MARK AS SHOWN.

THE MARK CONSISTS OF A DESIGN OF A PIG OVER THE LITERAL ELEMENT "VIRTUAL PIGGY".

CLASS 9—ELECTRICAL AND SCIENTIFIC APPARATUS

FOR INTERNET MONITORING AND SURVEILLANCE SOFTWARE, NAMELY, COMPUTER SOFTWARE FOR LIMITING ACCESS TO AND ACTIVITIES ON WEB SITES ON THE INTERNET, RECORDING AND TRACKING AND PROVIDING A RECORD OF A PERSON'S ACTIVITIES ON THE INTERNET, NAMELY, WEB SITES VISITED, E-MAIL CONTENT, CHAT/INSTANT MESSAGES CONTENT, KEYSTROKES AND SCREEN SHOTS, GENERATING COMPUTER USAGE REPORTS, AND SENDING E-MAIL ALERTS AND EVENT LOGS TO A PREDEFINED E-MAIL ADDRESS AND PASSWORD PROTECTED ONLINE PORTAL (U.S. CLS. 21, 23, 26, 36 AND 38).

CLASS 36—INSURANCE AND FINANCIAL

FOR ELECTRONIC COMMERCE PAYMENT SERVICES, NAMELY, ESTABLISHING AND ADMINISTERING ONLINE SPENDING PROFILES THAT ARE LINKED TO FUNDED ACCOUNTS OR CREDIT, DEBIT OR OTHER PAYMENT CARDS THAT CONTROL, FACILITATE AND ADMINISTER APPROVED PAYMENTS USED TO PURCHASE GOODS AND SERVICES ON THE INTERNET; PROVIDING ON-LINE PAYMENT PROCESSING AND MANAGEMENT OF CREDIT, DEBIT OR OTHER PAYMENT CARD TRANSACTIONS; DEBIT CARD SERVICES (U.S. CLS. 100, 101 AND 102).

CLASS 42—SCIENTIFIC AND COMPUTER SERVICES

FOR COMPUTER SERVICES, NAMELY, PROVIDING A WEB BASED SYSTEM AND ONLINE PORTAL FEATURING ONLINE NON-DOWNLOADABLE SOFTWARE THAT ENABLES CUSTOMERS, NAMELY, PARENTS AND GUARDIANS, TO LIMIT CHILDREN'S ACCESS TO OR ACTIVITIES AND SPENDING ON CERTAIN TYPES OF WEBSITES, APPLICATIONS AND INTERNET CONTENT, RECORD AND TRACK A CHILD'S ACTIVITIES ON THE INTERNET, NAMELY, WEB SITES VISITED, E-MAIL CONTENT, CHAT/INSTANT MESSAGES CONTENT, KEYSTROKES AND SCREEN SHOTS, GENERATE COMPUTER USAGE REPORTS, AND SEND ALERTS AND EVENT LOGS TO A PREDEFINED E-MAIL ADDRESS AND PASSWORD PROTECTED ONLINE PORTAL (U.S. CLS. 100 AND 101).

HOWARD SMIGA, EXAMINING ATTORNEY

SN 85-273,239. MOGGLE, INC., PHILADELPHIA, PA. FILED 3-22-2011.



NO CLAIM IS MADE TO THE EXCLUSIVE RIGHT TO USE "VIRTUAL", APART FROM THE MARK AS SHOWN. THE MARK CONSISTS OF A DESIGN OF A PIG NEXT TO THE LITERAL ELEMENT "VIRTUAL PIGGY".

CLASS 9—ELECTRICAL AND SCIENTIFIC APPARATUS

FOR INTERNET MONITORING AND SURVEILLANCE SOFTWARE, NAMELY, COMPUTER SOFTWARE FOR LIMITING ACCESS TO AND ACTIVITIES ON WEB SITES ON THE INTERNET, RECORDING AND TRACKING AND PROVIDING A RECORD OF A PERSON'S ACTIVITIES ON THE INTERNET, NAMELY, WEB SITES VISITED, E-MAIL CONTENT, CHAT/INSTANT MESSAGES CONTENT, KEYSTROKES AND SCREEN SHOTS, GENERATING COMPUTER USAGE REPORTS, AND SENDING E-MAIL ALERTS AND EVENT LOGS TO A PREDEFINED E-MAIL ADDRESS AND PASSWORD PROTECTED ONLINE PORTAL (U.S. CLS. 21, 23, 26, 36 AND 38).

CLASS 36—INSURANCE AND FINANCIAL

FOR ELECTRONIC COMMERCE PAYMENT SERVICES, NAMELY, ESTABLISHING AND ADMINISTERING ONLINE SPENDING PROFILES THAT ARE LINKED TO FUNDED ACCOUNTS OR CREDIT, DEBIT OR OTHER PAYMENT CARDS THAT CONTROL, FACILITATE AND ADMINISTER APPROVED PAYMENTS USED TO PURCHASE GOODS AND SERVICES ON THE INTERNET; PROVIDING ON-LINE PAYMENT PROCESSING AND MANAGEMENT OF CREDIT, DEBIT OR OTHER PAYMENT CARD TRANSACTIONS; DEBIT CARD SERVICES (U.S. CLS. 100, 101 AND 102).

CLASS 42—SCIENTIFIC AND COMPUTER SERVICES

FOR COMPUTER SERVICES, NAMELY, PROVIDING A WEB BASED SYSTEM AND ONLINE PORTAL FEATURING ONLINE NON-DOWNLOADABLE SOFTWARE THAT ENABLES CUSTOMERS, NAMELY, PARENTS AND GUARDIANS, TO LIMIT CHILDREN'S ACCESS TO OR ACTIVITIES AND SPENDING ON CERTAIN TYPES OF WEBSITES, APPLICATIONS AND INTERNET CONTENT, RECORD AND TRACK A CHILD'S ACTIVITIES ON THE INTERNET, NAMELY, WEB SITES VISITED, E-MAIL CONTENT, CHAT/INSTANT MESSAGES CONTENT, KEYSTROKES AND SCREEN SHOTS, GENERATE COMPUTER USAGE REPORTS, AND SEND ALERTS AND EVENT LOGS TO A PREDEFINED E-MAIL ADDRESS AND PASSWORD PROTECTED ONLINE PORTAL (U.S. CLS. 100 AND 101).

HOWARD SMIGA, EXAMINING ATTORNEY

SN 85-273,267. CRYO-CELL INTERNATIONAL, INC., OLDSMAR, FL. FILED 3-22-2011.



OWNER OF U.S. REG. NO. 3,496,023.
NO CLAIM IS MADE TO THE EXCLUSIVE RIGHT TO USE "INTERNATIONAL", APART FROM THE MARK AS SHOWN.

THE COLOR(S) BLUE, ORANGE AND BLACK IS/ARE CLAIMED AS A FEATURE OF THE MARK.

THE MARK CONSISTS OF THE STYLIZED WORDING "CRYOCELL INTERNATIONAL". "CRYOCELL" IS IN BLUE AND "INTERNATIONAL" IS BELOW IT IN SMALLER LETTERS IN BLACK. AN ORANGE SPHERE DESIGN CONNECTS THE LETTERS "O" AND "C" IN THE WORD "CRYOCELL".

CLASS 39—TRANSPORTATION AND STORAGE

FOR STORAGE OF HUMAN CELLS, BLOOD, AND TISSUE FOR THERAPEUTIC, BIOTECHNOLOGICAL, COSMETIC, PHARMACEUTICAL AND MEDICAL USE (U.S. CLS. 100 AND 105).

CLASS 44—MEDICAL, BEAUTY AND AGRICULTURAL SERVICES

FOR HUMAN BLOOD, CELL, AND TISSUE BANKING SERVICES; COLLECTION AND PRESERVATION OF HUMAN BLOOD, CELLS AND TISSUE (U.S. CLS. 100 AND 101).

JAMES GRIFFIN, EXAMINING ATTORNEY

SN 85-273,318. THE OUTER SPACE MEN HOLDING COMPANY, LLC, NEW YORK, NY. FILED 3-22-2011.

myfanpipe.com

THE MARK CONSISTS OF STANDARD CHARACTERS WITHOUT CLAIM TO ANY PARTICULAR FONT, STYLE, SIZE, OR COLOR.

CLASS 42—SCIENTIFIC AND COMPUTER SERVICES

FOR COMPUTER SERVICES, NAMELY, HOSTING ON-LINE WEB FACILITIES FOR OTHERS TO SHOW-CASE SONGWRITING AND MUSICAL TALENTS AND FOR FACILITATING AND CONDUCTING ONLINE CONNECTIONS, COLLABORATIONS, AND INTERACTIVE DISCUSSIONS ABOUT SONGWRITING AND MUSIC; COMPUTER SERVICES, NAMELY, UPLOADING MUSIC TO THE INTERNET FOR OTHERS; PROVIDING A WEBSITE ALLOWING USERS TO UPLOAD AND DOWNLOAD MUSIC; PROVIDING A WEBSITE THAT GIVES USERS THE ABILITY TO VOTE FOR THEIR FAVORITE MUSICAL ARTISTS (U.S. CLS. 100 AND 101).

CLASS 45—PERSONAL AND LEGAL SERVICES

FOR ONLINE SOCIAL NETWORKING SERVICES IN THE FIELD OF MUSIC, COMIC BOOKS, MOVIE AND TELEVISION SCRIPTS TO A FAN BASE OF SUBSCRIBING USERS (U.S. CLS. 100 AND 101).

JACQUELINE A. LAVINE, EXAMINING ATTORNEY

SN 85-273,356. THE OUTER SPACE MEN HOLDING COMPANY, LLC, NEW YORK, NY. FILED 3-22-2011.

PIPELINE.COM

THE MARK CONSISTS OF STANDARD CHARACTERS WITHOUT CLAIM TO ANY PARTICULAR FONT, STYLE, SIZE, OR COLOR.

CLASS 42—SCIENTIFIC AND COMPUTER SERVICES

FOR COMPUTER SERVICES, NAMELY, CREATING AN ON-LINE COMMUNITY FOR REGISTERED USERS TO PARTICIPATE IN DISCUSSIONS, GET FEEDBACK FROM THEIR PEERS, FORM VIRTUAL COMMUNITIES, AND ENGAGE IN SOCIAL NETWORKING FEATURING ORIGINAL MUSIC, COMIC BOOKS, MOVIE AND TELEVISION SCRIPTS TO A FAN BASE OF SUBSCRIBING USERS.; COMPUTER SERVICES, NAMELY, HOSTING ON-LINE WEB FACILITIES FOR OTHERS TO SHOW-CASE SONGWRITING AND MUSICAL TALENTS AND FOR FACILITATING AND CONDUCTING ONLINE CONNECTIONS, COLLABORATIONS, AND INTERACTIVE DISCUSSIONS ABOUT SONGWRITING AND MUSIC; COMPUTER SERVICES, NAMELY, UPLOADING MUSIC TO THE INTERNET FOR OTHERS; PROVIDING A WEBSITE ALLOWING USERS TO UPLOAD AND DOWNLOAD MUSIC; PROVIDING A WEBSITE THAT GIVES USERS THE ABILITY TO VOTE FOR THEIR FAVORITE MUSICAL ARTISTS (U.S. CLS. 100 AND 101).

CLASS 45—PERSONAL AND LEGAL SERVICES

FOR ONLINE SOCIAL NETWORKING SERVICES IN THE FIELD OF MUSIC, COMIC BOOKS, MOVIE AND TELEVISION SCRIPTS TO A FAN BASE OF SUBSCRIBING USERS (U.S. CLS. 100 AND 101).
JACQUELINE A. LAVINE, EXAMINING ATTORNEY

SN 85-273,378. ALL AMERICAN SPECIALTY VEHICLES, LLC, MIDDLEBURY, IN. FILED 3-22-2011.

WAVE-FUSION

THE MARK CONSISTS OF STANDARD CHARACTERS WITHOUT CLAIM TO ANY PARTICULAR FONT, STYLE, SIZE, OR COLOR.

CLASS 40—MATERIAL TREATMENT

FOR MANUFACTURING OF CUSTOM FURNITURE AND FURNITURE PARTS AND COMPONENTS FOR OTHERS (U.S. CLS. 100, 103 AND 106).

CLASS 42—SCIENTIFIC AND COMPUTER SERVICES

FOR CUSTOM DESIGN AND ENGINEERING OF FURNITURE AND FURNITURE PARTS AND COMPONENTS FOR OTHERS (U.S. CLS. 100 AND 101).
KATHY DE JONGE, EXAMINING ATTORNEY

SN 85-273,389. WATERMAN, JOHN D., WISCONSIN DELLS, WI. FILED 3-22-2011.

**BIGGEST LITTLE WATERPARK
IN WISCONSIN**

THE MARK CONSISTS OF STANDARD CHARACTERS WITHOUT CLAIM TO ANY PARTICULAR FONT, STYLE, SIZE, OR COLOR.

NO CLAIM IS MADE TO THE EXCLUSIVE RIGHT TO USE "WATERPARK IN WISCONSIN", APART FROM THE MARK AS SHOWN.

CLASS 41—EDUCATION AND ENTERTAINMENT

FOR ENTERTAINMENT AND RECREATIONAL SERVICES, NAMELY, OUTDOOR AND INDOOR WATER-PARK SERVICES; ARCADE SERVICES FEATURING COIN-OPERATED AMUSEMENT DEVICES (U.S. CLS. 100, 101 AND 107).

CLASS 43—HOTEL AND RESTAURANT SERVICES

FOR HOTEL, RESORT LODGING, CONFERENCE FACILITIES AND RELATED HOSPITALITY SERVICES, NAMELY, SERVING OF FOOD AND DRINK, SNACK BAR AND RESTAURANT SERVICES (U.S. CLS. 100 AND 101).

PATRICIA EVANKO, EXAMINING ATTORNEY

SN 85-273,511. SUMMIT INDUSTRIES, INC., MARIETTA, GA. FILED 3-22-2011.

LANOGUARD

THE MARK CONSISTS OF STANDARD CHARACTERS WITHOUT CLAIM TO ANY PARTICULAR FONT, STYLE, SIZE, OR COLOR.

CLASS 3—COSMETICS AND CLEANING PREPARATIONS

FOR TOPICAL PRODUCTS, NAMELY, TOPICAL COSMETIC PREPARATIONS, FOR THE SKIN (U.S. CLS. 1, 4, 6, 50, 51 AND 52).

CLASS 5—PHARMACEUTICALS

FOR TOPICAL PRODUCTS, NAMELY, TOPICAL PHARMACEUTICAL PREPARATIONS, FOR MEDICAL AND THERAPEUTIC TREATMENT OF SKIN (U.S. CLS. 6, 18, 44, 46, 51 AND 52).

JAMES MACFARLANE, EXAMINING ATTORNEY

SN 85-273,516. CRYO-CELL INTERNATIONAL, INC., OLD-SMAR, FL. FILED 3-22-2011.

**SOLUCIONES INNOVADORAS EN
CÉLULAS MADRE**

THE MARK CONSISTS OF STANDARD CHARACTERS WITHOUT CLAIM TO ANY PARTICULAR FONT, STYLE, SIZE, OR COLOR.

NO CLAIM IS MADE TO THE EXCLUSIVE RIGHT TO USE "SOLUCIONES EN CÉLULAS MADRE", APART FROM THE MARK AS SHOWN.

THE ENGLISH TRANSLATIONS OF "SOLUCIONES INNOVADORAS EN CÉLULAS MADRE" IS "INNOVATIVE STEM CELL SOLUTIONS".

SN 85-273,566. AYNA, LLC, SAN ANTONIO, TX. FILED 3-22-2011.

CLASS 39—TRANSPORTATION AND STORAGE

FOR STORAGE OF HUMAN CELLS, BLOOD, AND TISSUE FOR THERAPEUTIC, BIOTECHNOLOGICAL, COSMETIC, PHARMACEUTICAL AND MEDICAL USE (U.S. CLS. 100 AND 105).

Alone, Yet Not Alone

CLASS 44—MEDICAL, BEAUTY AND AGRICULTURAL SERVICES

FOR HUMAN BLOOD, CELL, AND TISSUE BANKING SERVICES; COLLECTION AND PRESERVATION OF HUMAN BLOOD, CELLS AND TISSUE (U.S. CLS. 100 AND 101).

JAMES GRIFFIN, EXAMINING ATTORNEY

THE MARK CONSISTS OF STANDARD CHARACTERS WITHOUT CLAIM TO ANY PARTICULAR FONT, STYLE, SIZE, OR COLOR.

CLASS 9—ELECTRICAL AND SCIENTIFIC APPARATUS

FOR MOTION PICTURE FILMS ABOUT HISTORY AND PERSONAL ACHIEVEMENT (U.S. CLS. 21, 23, 26, 36 AND 38).

CLASS 16—PAPER GOODS AND PRINTED MATTER

FOR SERIES OF NON-FICTION BOOKS IN THE FIELD OF HISTORY AND PERSONAL ACHIEVEMENT (U.S. CLS. 2, 5, 22, 23, 29, 37, 38 AND 50).

HANNO RITTNER, EXAMINING ATTORNEY

SN 85-273,547. INTEGRATED SOLUTIONS HEALTH NETWORK, LLC, JOHNSON CITY, TN. FILED 3-22-2011.

SN 85-273,604. J. KAHN CORPORATION, WEST BLOOMFIELD, MI. FILED 3-22-2011.



THE COLOR(S) BLUE AND YELLOW IS/ARE CLAIMED AS A FEATURE OF THE MARK.

THE MARK CONSISTS OF THE WORDS "CRESTPOINT" IN BLUE WITH A MOUNTAIN CREST ABOVE THE WORDS, WHICH CREST IS COMPRISED OF EIGHT RAYS, WITH TWO BLUE RAYS ON EACH SIDE OF THE CREST AND FOUR YELLOW RAYS IN THE MIDDLE OF THE CREST AS WELL AS A YELLOW HORIZON LINE AT THE BOTTOM OF THE MOUNTAIN CREST.

THE MARK CONSISTS OF STANDARD CHARACTERS WITHOUT CLAIM TO ANY PARTICULAR FONT, STYLE, SIZE, OR COLOR.

INTERPREVENTIONAL

CLASS 36—INSURANCE AND FINANCIAL

FOR ADMINISTRATION AND MANAGEMENT OF PREPAID HEALTH CARE PLANS OF HEALTH MAINTENANCE ORGANIZATIONS AND PREFERRED PROVIDER ORGANIZATIONS; MEDICAL INSURANCE UNDERWRITING SERVICES (U.S. CLS. 100, 101 AND 102).

CLASS 41—EDUCATION AND ENTERTAINMENT

FOR EDUCATION SERVICES, NAMELY, CLASSES, SEMINARS, WORKSHOPS, ONLINE INSTRUCTION, MENTORING, MOTIVATIONAL SPEAKERS AND PROVIDING ONLINE NON-DOWNLOADABLE VIDEOS IN THE FIELD OF HEALTH, NUTRITION AND HEALTHY LIVING (U.S. CLS. 100, 101 AND 107).

CLASS 44—MEDICAL, BEAUTY AND AGRICULTURAL SERVICES

FOR HEALTH CARE SERVICES IN THE NATURE OF HEALTH MAINTENANCE ORGANIZATIONS AND PREFERRED PROVIDER ORGANIZATIONS (U.S. CLS. 100 AND 101).

BRIAN CALLAGHAN, EXAMINING ATTORNEY

CLASS 44—MEDICAL, BEAUTY AND AGRICULTURAL SERVICES

FOR MEDICAL SERVICES; MEDICAL INFORMATION; PROVIDING A WEBSITE FEATURING INFORMATION ABOUT HEALTH, WELLNESS AND NUTRITION (U.S. CLS. 100 AND 101).

MARK PILARO, EXAMINING ATTORNEY

SN 85-273,606. WORLD VISION, INC., FEDERAL WAY, WA. FILED 3-22-2011.

KIDREACH

THE MARK CONSISTS OF STANDARD CHARACTERS WITHOUT CLAIM TO ANY PARTICULAR FONT, STYLE, SIZE, OR COLOR.

CLASS 35—ADVERTISING AND BUSINESS

FOR CHARITABLE SERVICES, NAMELY, ORGANIZING AND DEVELOPING PROJECTS THAT AIM TO IMPROVE THE LIVES OF UNDERPRIVILEGED CHILDREN THROUGH AFTER-SCHOOL PROGRAMS, MENTORING, AND TUTORING CONDUCTED BY OTHERS IN THE ACADEMICS AND EDUCATIONAL LEARNING FIELDS; CHARITABLE SERVICES, NAMELY, ORGANIZING AND CONDUCTING VOLUNTEER PROGRAMS IN THE ACADEMICS AND EDUCATIONAL LEARNING FIELDS AIMED AT TRAINING OTHERS TO PROVIDE ACADEMIC TUTORING AND MENTORING TO AT-RISK CHILDREN (U.S. CLS. 100, 101 AND 102).
FIRST USE 12-31-1995; IN COMMERCE 12-31-1995.

CLASS 36—INSURANCE AND FINANCIAL

FOR CHARITABLE FUNDRAISING TO FUND PROJECTS AND VOLUNTEER PROGRAMS IN THE ACADEMIC AND EDUCATIONAL LEARNING FIELDS FOR AT-RISK AND UNDERPRIVILEGED CHILDREN (U.S. CLS. 100, 101 AND 102).
FIRST USE 12-31-1995; IN COMMERCE 12-31-1995.

CLASS 41—EDUCATION AND ENTERTAINMENT

FOR EDUCATION SERVICES, NAMELY, PROVIDING TRAINING FOR PROGRAMS THAT RUN ACADEMIC MENTORING PROGRAMS TO AT-RISK, SCHOOL-AGE CHILDREN; CHARITABLE SERVICES, NAMELY, TRAINING VOLUNTEERS TO MENTOR AT-RISK, SCHOOL-AGE CHILDREN THROUGH AFTER-SCHOOL PROGRAMS, MENTORING, AND TUTORING IN THE ACADEMICS AND EDUCATIONAL LEARNING FIELDS (U.S. CLS. 100, 101 AND 107).
FIRST USE 12-31-1995; IN COMMERCE 12-31-1995.
JUDITH HELFMAN, EXAMINING ATTORNEY

SN 85-273,635. J. KAHN CORPORATION, WEST BLOOMFIELD, MI. FILED 3-22-2011.

PREVENT NOT STENT

THE MARK CONSISTS OF STANDARD CHARACTERS WITHOUT CLAIM TO ANY PARTICULAR FONT, STYLE, SIZE, OR COLOR.

CLASS 41—EDUCATION AND ENTERTAINMENT

FOR EDUCATION SERVICES, NAMELY, CLASSES, SEMINARS, WORKSHOPS, ONLINE INSTRUCTION, MENTORING, MOTIVATIONAL SPEAKERS AND PROVIDING ONLINE NON-DOWNLOADABLE VIDEOS IN THE FIELD OF HEALTH, NUTRITION AND HEALTHY LIVING (U.S. CLS. 100, 101 AND 107).

CLASS 44—MEDICAL, BEAUTY AND AGRICULTURAL SERVICES

FOR MEDICAL SERVICES; MEDICAL INFORMATION; PROVIDING A WEBSITE FEATURING INFORMATION ABOUT HEALTH, WELLNESS AND NUTRITION (U.S. CLS. 100 AND 101).
MARK PILARO, EXAMINING ATTORNEY

SN 85-273,796. VUCUREVICH SIMONS ADVISORY GROUP, LLC, KENSINGTON, MD. FILED 3-22-2011.

LADDER THEORY

THE MARK CONSISTS OF STANDARD CHARACTERS WITHOUT CLAIM TO ANY PARTICULAR FONT, STYLE, SIZE, OR COLOR.

CLASS 35—ADVERTISING AND BUSINESS

FOR PROVIDING TECHNICAL ASSISTANCE DURING THE INITIAL ESTABLISHMENT AND OPERATION OF RESTAURANTS, NAMELY, OFFERING BUSINESS MANAGEMENT ASSISTANCE IN THE ESTABLISHMENT AND/OR OPERATION OF RESTAURANTS (U.S. CLS. 100, 101 AND 102).
FIRST USE 9-0-2010; IN COMMERCE 9-0-2010.

CLASS 43—HOTEL AND RESTAURANT SERVICES

FOR PROVIDING TECHNICAL ASSISTANCE DURING THE INITIAL ESTABLISHMENT AND OPERATION OF RESTAURANTS, NAMELY, CONSULTING SERVICES IN THE FIELD OF CULINARY ARTS FOR RESTAURANTS; RESTAURANT CONSULTING SERVICES, NAMELY, CONSULTING IN RELATION TO RESTAURANT MENU ANALYSIS AND DEVELOPMENT (U.S. CLS. 100 AND 101).
FIRST USE 9-0-2010; IN COMMERCE 9-0-2010.
MELISSA VALLILLO, EXAMINING ATTORNEY

SN 85-274,158. CASTBOOK LLC, FT. LAUDERDALE, FL. FILED 3-23-2011.

CASTBOOK

THE MARK CONSISTS OF STANDARD CHARACTERS WITHOUT CLAIM TO ANY PARTICULAR FONT, STYLE, SIZE, OR COLOR.

CLASS 35—ADVERTISING AND BUSINESS

FOR PROFESSIONAL STAFFING AND RECRUITING SERVICES, NAMELY, EMPLOYMENT SERVICES IN THE NATURE OF TALENT CASTING IN THE FIELD(S) OF ENTERTAINMENT INDUSTRY; PROMOTING THE SERVICES OF OTHERS, NAMELY, PROVIDING A WEBSITE AT WHICH ARTISTS AND PERFORMERS CAN SHOWCASE THEIR TALENTS VIA AN ONLINE PORTFOLIO; EMPLOYMENT AGENCY SERVICES, NAMELY, PROVIDING A WEB SITE WITH ONLINE VIDEO, AUDIO AND TEXTUAL INTERVIEWING APPLICATIONS TO SUPPORT RECRUITING AND GENERAL CANDIDATE SCREENING PROCESSES FOR THE ENTERTAINMENT INDUSTRY; PROVIDING AN ONLINE SEARCHABLE DATABASE FOR USE BY ENTERTAINERS, ARTISTS AND PERFORMERS FEATURING EMPLOYMENT OPPORTUNITIES AND CONTENT ABOUT EMPLOYMENT IN THE ENTERTAINMENT INDUSTRY; PROVIDING AN ON-LINE SEARCHABLE DATABASE FOR USE BY BOOKING AGENTS AND CASTING AGENTS FEATURING BUSINESS EMPLOYMENT INFORMATION ABOUT ENTERTAINERS, ARTISTS AND PERFORMERS SEEKING EMPLOYMENT IN THE ENTERTAINMENT INDUSTRY; PROVIDING ON-LINE EMPLOYMENT PLACEMENT SERVICES, NAMELY, MATCHING RESUMES AND POTENTIAL EMPLOYERS VIA A GLOBAL COMPUTER NETWORK; EMPLOYMENT SERVICES IN THE NATURE OF TALENT CASTING IN THE FIELDS OF MUSIC, VIDEO, AND FILMS (U.S. CLS. 100, 101 AND 102).

CLASS 41—EDUCATION AND ENTERTAINMENT

FOR PROVIDING AN ON-LINE SEARCHABLE DATABASE FOR USE BY BOOKING AGENTS AND CASTING AGENTS FEATURING ENTERTAINMENT INFORMATION ABOUT ENTERTAINERS, ARTISTS AND PERFORMERS SEEKING EMPLOYMENT IN THE ENTERTAINMENT INDUSTRY (U.S. CLS. 100, 101 AND 107).

TRACY WHITTAKER-BROWN, EXAMINING ATTORNEY

SN 85-274,175. CUSTOMIZED TECHNOLOGY SERVICES, INC., CARY, NC. FILED 3-23-2011.

EMUNIKAY

THE MARK CONSISTS OF STANDARD CHARACTERS WITHOUT CLAIM TO ANY PARTICULAR FONT, STYLE, SIZE, OR COLOR.

CLASS 9—ELECTRICAL AND SCIENTIFIC APPARATUS

FOR COMPUTER SOFTWARE FOR DELIVERING ELECTRONIC COMMUNICATIONS AND DATA FILES AMONG USERS OF COMPUTERS, MOBILE PHONES, PERSONAL DIGITAL ASSISTANTS, AND OTHER ELECTRONIC DEVICES (U.S. CLS. 21, 23, 26, 36 AND 38).

CLASS 38—COMMUNICATION

FOR COMMUNICATION SERVICES, NAMELY, ELECTRONIC TRANSMISSION OF VOICE, AUDIO, VISUAL IMAGES AND DATA BY TELECOMMUNICATIONS NETWORKS, WIRELESS COMMUNICATION NETWORKS, THE INTERNET, INFORMATION SERVICES NETWORKS AND DATA NETWORKS AMONG USERS OF COMPUTERS, MOBILE PHONES, PERSONAL DIGITAL ASSISTANTS, AND OTHER ELECTRONIC DEVICES (U.S. CLS. 100, 101 AND 104).

ROBIN CHOSID, EXAMINING ATTORNEY

SN 85-274,232. CULLEN, INC., NEW YORK, NY. FILED 3-23-2011.



NO CLAIM IS MADE TO THE EXCLUSIVE RIGHT TO USE "CAMO", APART FROM THE MARK AS SHOWN.

THE MARK CONSISTS OF TWO LETTER "U'S FACING AWAY FROM EACH OTHER AT A 45 DEGREE ANGLE, BETWEEN WHICH IS A SQUARE WITH A ROUNDED CORNER AND WITH A STAR INSIDE. UNDERNEATH THE FOREGOING ARE THE WORDS "URBAN CAMO" IN STYLIZED LETTERS, UNDERNEATH OF WHICH IS THE WORD "BRIGADE" IN STYLIZED LETTERS.

CLASS 18—LEATHER GOODS

FOR BACKPACKS (U.S. CLS. 1, 2, 3, 22 AND 41).

CLASS 25—CLOTHING

FOR CLOTHING, NAMELY, SWEATERS, HATS, CAPS, WOVEN SHIRTS, JEANS, KNIT T-SHIRTS, KNIT POLO SHIRTS, KNIT JACKETS, KNIT TOPS, OUTERWEAR COATS AND JACKETS (U.S. CLS. 22 AND 39).

JILL PRATER, EXAMINING ATTORNEY

SN 85-274,235. CULLEN, INC., NEW YORK, NY. FILED 3-23-2011.

URBAN CAMO BRIGADE

THE MARK CONSISTS OF STANDARD CHARACTERS WITHOUT CLAIM TO ANY PARTICULAR FONT, STYLE, SIZE, OR COLOR.

NO CLAIM IS MADE TO THE EXCLUSIVE RIGHT TO USE "CAMO", APART FROM THE MARK AS SHOWN.

CLASS 18—LEATHER GOODS

FOR BACKPACKS (U.S. CLS. 1, 2, 3, 22 AND 41).

CLASS 25—CLOTHING

FOR CLOTHING, NAMELY, SWEATERS, HATS, CAPS, WOVEN SHIRTS, JEANS, KNIT T-SHIRTS, KNIT POLO SHIRTS, KNIT JACKETS, KNIT TOPS, OUTERWEAR COATS AND JACKETS (U.S. CLS. 22 AND 39).

JILL PRATER, EXAMINING ATTORNEY

SN 85-274,249. CHOU, DENNIS, SECAUCUS, NJ. FILED 3-23-2011.

BODYPOST

THE MARK CONSISTS OF STANDARD CHARACTERS WITHOUT CLAIM TO ANY PARTICULAR FONT, STYLE, SIZE, OR COLOR.

CLASS 25—CLOTHING

FOR ATHLETIC APPAREL, NAMELY, SHIRTS, PANTS, JACKETS, FOOTWEAR, HATS AND CAPS, ATHLETIC UNIFORMS; SHOES; SLEEPWEAR; T-SHIRTS; UNDERWEAR (U.S. CLS. 22 AND 39).

CLASS 28—TOYS AND SPORTING GOODS

FOR BALLS FOR GAMES; BASEBALL MITTS; BASKETBALLS; BODY PROTECTORS FOR FOOTBALL, HOCKEY, BASEBALL, BOXING, AND MARTIAL ARTS; FIELD HOCKEY BALLS; FIELD HOCKEY GLOVES; FIELD HOCKEY GOALIE PADS; FIELD HOCKEY STICK BAGS; FIELD HOCKEY STICKS; FOOTBALLS; HOCKEY GLOVES; HOCKEY GOALS; HOCKEY PUCKS; ICE HOCKEY GOALIE PADS; SOFTBALL MITTS; SPORTS EQUIPMENT FOR BOXING AND MARTIAL ARTS, NAMELY, BOXING GLOVES, BOXING BAGS, PUNCHING MITTS, BELLY PROTECTORS, GROIN PROTECTORS AND SHIN GUARDS; TENNIS RACQUETS, BASEBALL BATS, CRICKET BATS, GOLF CLUBS AND HOCKEY STICKS (U.S. CLS. 22, 23, 38 AND 50).

TRACY WHITTAKER-BROWN, EXAMINING ATTORNEY

SN 85-274,380. PEAC, DBA PARROT EDUCATION & ADOPTION CENTER, SAN DIEGO, CA. FILED 3-23-2011.



THE COLOR(S) GREEN, YELLOW, BLUE, RED, WHITE, GREY, ORANGE, TAN, BLACK, WHITE, LIGHT GREY AND DARK GREY IS/ARE CLAIMED AS A FEATURE OF THE MARK.

THE MARK CONSISTS OF LETTER "P" COMPRISED OF 1 UPRIGHT FEATHER OF GREEN, YELLOW, AND BLUE AND 2 HORIZONTAL FEATHERS OF BLUE, BLACK, AND YELLOW COLORS WITH WHITE BIRD SITTING ON TOP; LETTER "O" COMPRISED OF 1 VERTICAL FEATHER OF BLUE, BLACK AND TAN, 2 HORIZONTAL FEATHERS OF GREEN AND BLUE AND 1 HORIZONTAL FEATHER OF YELLOW, WITH BIRD SITTING ON TOP WITH YELLOW HEAD AND CHEST, GREEN SIDES WITH RED ON EDGE OF WING; LETTER "A" COMPRISED OF 2 VERTICAL FEATHERS OF YELLOW, GREEN, AND RED, AND ONE HORIZONTAL FEATHER OF GREY AND WHITE WITH BIRD SITTING ON TOP WITH BLUE BREAST, GREY AND WHITE HEAD AND BLUE WITH BLACK WINGS; AND LETTER "C" COMPRISED OF ONE ORANGE FEATHER WITH BIRD SITTING ON TOP WITH LIGHT GREY HEAD AND BREAST, DARK GREY WINGS AND RED AND BLACK TAIL.

CLASS 41—EDUCATION AND ENTERTAINMENT

FOR EDUCATION SERVICES, NAMELY, CLASSES AND LECTURES ON THE SUBJECT OF PARROTS AND PARROT CARE; TRAINING SERVICES IN THE FIELD OF PARROT CARE (U.S. CLS. 100, 101 AND 107). FIRST USE 1-1-1996; IN COMMERCE 1-1-1996.

CLASS 45—PERSONAL AND LEGAL SERVICES

FOR ADOPTION SERVICES FOR DOMESTIC ANIMALS, NAMELY, ADOPTION SERVICES FOR PARROTS (U.S. CLS. 100 AND 101).

FIRST USE 1-1-1996; IN COMMERCE 1-1-1996.

KATHERINE E. HALMEN, EXAMINING ATTORNEY

SN 85-274,677. ROBBINS-GIOIA, LLC, ALEXANDRIA, VA. FILED 3-23-2011.

ROBBINS-GIOIA

THE MARK CONSISTS OF STANDARD CHARACTERS WITHOUT CLAIM TO ANY PARTICULAR FONT, STYLE, SIZE, OR COLOR.

OWNER OF U.S. REG. NOS. 3,127,472, 3,313,010 AND 3,920,309.

THE ENGLISH TRANSLATION OF THE WORD "GIOIA" IN THE MARK IS "GLEE" OR "JOY".

CLASS 16—PAPER GOODS AND PRINTED MATTER

FOR PUBLICATIONS, NAMELY, WHITE PAPERS, RESEARCH REPORTS, JOURNALS, GUIDES, AND PERIODICALS IN THE FIELDS OF PROJECT, PROGRAM, AND PORTFOLIO MANAGEMENT (U.S. CLS. 2, 5, 22, 23, 29, 37, 38 AND 50).

FIRST USE 0-0-1999; IN COMMERCE 0-0-1999.

CLASS 35—ADVERTISING AND BUSINESS

FOR BUSINESS CONSULTATION, NAMELY, PROGRAM AND PROJECT MANAGEMENT CONSULTATION FOR OTHERS (U.S. CLS. 100, 101 AND 102).

FIRST USE 0-0-1980; IN COMMERCE 0-0-1980.

CLASS 41—EDUCATION AND ENTERTAINMENT

FOR EDUCATIONAL SERVICES, NAMELY, PROVIDING COURSES IN THE FIELD OF PROJECT MANAGEMENT; TRAINING SERVICES IN THE FIELD OF PROJECT MANAGEMENT AND DISTRIBUTION OF TRAINING MATERIALS IN CONNECTION THEREWITH (U.S. CLS. 100, 101 AND 107).

FIRST USE 0-0-1980; IN COMMERCE 0-0-1980.

CLASS 42—SCIENTIFIC AND COMPUTER SERVICES

FOR PROVIDING COMPUTER PROJECT MANAGEMENT SERVICES (U.S. CLS. 100 AND 101).

FIRST USE 0-0-1980; IN COMMERCE 0-0-1980.

HEATHER THOMPSON, EXAMINING ATTORNEY

SN 85-274,700. ROBBINS-GIOIA, LLC, ALEXANDRIA, VA.
FILED 3-23-2011.

SN 85-274,744. STEVE EBY, ATLANTA, GA. FILED 3-23-2011.

ROBBINS GIOIA

THE MARK CONSISTS OF STANDARD CHARACTERS WITHOUT CLAIM TO ANY PARTICULAR FONT, STYLE, SIZE, OR COLOR.

OWNER OF U.S. REG. NOS. 3,127,472, 3,313,010 AND 3,920,309.

THE ENGLISH TRANSLATION OF THE WORD "GIOIA" IN THE MARK IS "GLEE" OR "JOY".

CLASS 9—ELECTRICAL AND SCIENTIFIC APPARATUS

FOR COMPUTER SOFTWARE FOR USE IN PROJECT MANAGEMENT SUPPORT COMPRISING TRACKING, REPORTING, MODELING, PLANNING, SCHEDULING, AND CHARTING; ELECTRONIC PUBLICATIONS, NAMELY, WHITE PAPERS, REPORTS, JOURNALS, GUIDES, AND PERIODICALS IN THE FIELD OF PROGRAM AND PROJECT MANAGEMENT RECORDED ON COMPUTER MEDIA (U.S. CLS. 21, 23, 26, 36 AND 38).
FIRST USE 0-0-2003; IN COMMERCE 0-0-2003.

CLASS 16—PAPER GOODS AND PRINTED MATTER

FOR PUBLICATIONS, NAMELY, WHITE PAPERS, RESEARCH REPORTS, JOURNALS, GUIDES, AND PERIODICALS IN THE FIELDS OF PROJECT, PROGRAM, AND PORTFOLIO MANAGEMENT (U.S. CLS. 2, 5, 22, 23, 29, 37, 38 AND 50).
FIRST USE 0-0-2003; IN COMMERCE 0-0-2003.

CLASS 35—ADVERTISING AND BUSINESS

FOR BUSINESS CONSULTATION, NAMELY, PROGRAM AND PROJECT MANAGEMENT CONSULTATION FOR OTHERS (U.S. CLS. 100, 101 AND 102).
FIRST USE 0-0-1980; IN COMMERCE 0-0-1980.

CLASS 41—EDUCATION AND ENTERTAINMENT

FOR EDUCATIONAL SERVICES, NAMELY, PROVIDING COURSES IN THE FIELD OF PROJECT MANAGEMENT; TRAINING SERVICES IN THE FIELD OF PROJECT MANAGEMENT AND DISTRIBUTION OF TRAINING MATERIALS IN CONNECTION THEREWITH (U.S. CLS. 100, 101 AND 107).
FIRST USE 0-0-1980; IN COMMERCE 0-0-1980.

CLASS 42—SCIENTIFIC AND COMPUTER SERVICES

FOR PROVIDING COMPUTER PROJECT MANAGEMENT SERVICES (U.S. CLS. 100 AND 101).
FIRST USE 0-0-1980; IN COMMERCE 0-0-1980.
HEATHER THOMPSON, EXAMINING ATTORNEY



NO CLAIM IS MADE TO THE EXCLUSIVE RIGHT TO USE "COFFEE", APART FROM THE MARK AS SHOWN.

THE MARK CONSISTS OF A "LADY" WEARING A DRESS LEAPING IN THE AIR WITH BOTH ARMS UPRIGHT ATOP A "SUN" WITH "WAVY" HORIZON AT ITS BASE. BELOW THERE IS THE STYLIZED TEXT "FREEBORN COFFEE".

CLASS 30—STAPLE FOODS

FOR COFFEE (U.S. CL. 46).

CLASS 43—HOTEL AND RESTAURANT SERVICES

FOR COFFEE SHOPS (U.S. CLS. 100 AND 101).
ASMAT KHAN, EXAMINING ATTORNEY

SN 85-274,899. SPARTAN TERMINALS LP, THE WOODLANDS, TX. FILED 3-23-2011.

Spartan Energy

THE MARK CONSISTS OF STANDARD CHARACTERS WITHOUT CLAIM TO ANY PARTICULAR FONT, STYLE, SIZE, OR COLOR.

NO CLAIM IS MADE TO THE EXCLUSIVE RIGHT TO USE "ENERGY", APART FROM THE MARK AS SHOWN.

CLASS 39—TRANSPORTATION AND STORAGE

FOR TRANSPORTATION AND STORAGE OF NATURAL GAS AND CRUDE OIL FOR OTHERS BY PIPELINE (U.S. CLS. 100 AND 105).

CLASS 40—MATERIAL TREATMENT

FOR PROCESSING AND TREATING OF NATURAL GAS, HYDROCARBON CONDENSATES, AND OIL (U.S. CLS. 100, 103 AND 106).
ANTHONY RINKER, EXAMINING ATTORNEY

SN 85-274,920. QOOQOO, LLC, IRVINE, CA. FILED 3-23-2011.



THE MARK CONSISTS OF THE WORD "QOOQOO" WITH CIRCLES INSIDE THE FIRST SET OF "OO"'S AND CIRCLES INSIDE THE SECOND SET OF "OO"'S.

CLASS 35—ADVERTISING AND BUSINESS

FOR ADVERTISING SERVICES, NAMELY, CREATING CORPORATE AND BRAND IDENTITY FOR OTHERS; BRAND CONCEPT AND BRAND DEVELOPMENT SERVICES FOR CORPORATE AND INDIVIDUAL CLIENTS; BRANDING SERVICES, NAMELY, CONSULTING, DEVELOPMENT, MANAGEMENT AND MARKETING OF BRANDS FOR BUSINESSES; CREATIVE MARKETING DESIGN SERVICES; DESIGN OF ADVERTISING MATERIALS FOR OTHERS; BUSINESS ADVISE AND ANALYSIS OF MARKETS. BUSINESS CONSULTATION AND MANAGEMENT REGARDING MARKETING ACTIVITIES AND LAUNCHING OF NEW PRODUCTS; BUSINESS CONSULTATION SERVICES; BUSINESS MONITORING AND CONSULTING SERVICES, NAMELY, TRACKING WEB SITES AND APPLICATIONS OF OTHERS TO PROVIDE STRATEGY, INSIGHT, MARKETING, SALES, OPERATION, AND PRODUCT DESIGN; MEDIA BUYING ADVICE, NAMELY, ADVISING THE CLIENT HOW MUCH MEDIA TIME, AND AT WHAT TIMES THE CLIENT SHOULD BE PURCHASING ADVERTISING; MEDIA PLANNING, NAMELY, ADVISING THE CLIENT ON THE CORRECT TIMES AND STATIONS TO ADVERTISE BASED ON MEDIA ANALYSIS OF THE MARKET FOR THAT MEDIA; SOCIAL MEDIA STRATEGY AND MARKETING CONSULTANCY FOCUSING ON HELPING CLIENTS CREATE AND EXTEND THEIR PRODUCT AND BRAND STRATEGIES (U.S. CLS. 100, 101 AND 102).

FIRST USE 3-21-2011; IN COMMERCE 3-21-2011.

CLASS 38—COMMUNICATION

FOR COMPUTER SERVICES, NAMELY, MESSAGE SENDING, RECEIVING AND FORWARDING (U.S. CLS. 100, 101 AND 104).

FIRST USE 3-21-2011; IN COMMERCE 3-21-2011.

CLASS 42—SCIENTIFIC AND COMPUTER SERVICES

FOR COMPUTER SERVICES, NAMELY, DESIGNING AND IMPLEMENTING NETWORK WEB PAGES FOR OTHERS; COMPUTER SERVICES, NAMELY, DESIGNING AND IMPLEMENTING WEB SITES FOR OTHERS; COMPUTER SERVICES, NAMELY, MANAGING WEB SITES FOR OTHERS; COMPUTER SERVICES, NAMELY, MONITORING AND REPORTING ON THE PERFORMANCE, AVAILABILITY, AND ERRORS OF WEB SITES OF OTHERS; COMPUTER SERVICES, NAMELY, MONITORING THE WEB SITES OF OTHERS TO IMPROVE SCALABILITY AND PERFORMANCE OF WEB SITES OF OTHERS; COMPUTER SERVICES, NAMELY, MONITORING, TESTING, ANALYZING, AND REPORTING ON THE INTERNET TRAFFIC CONTROL AND CONTENT CONTROL OF THE WEB SITES OF OTHERS; COMPUTER SERVICES, NAMELY, SEARCH ENGINE OPTIMIZATION; COMPUTER SOFTWARE DEVELOPMENT IN THE FIELD OF MOBILE APPLICATIONS; CONSULTATION SERVICES IN THE FIELD OF SEARCH ENGINE OPTIMIZATION; CREATING AND DESIGNING WEB PAGES FOR OTHERS; CREATING AND MAINTAINING BLOGS FOR OTHERS; CREATING OR MAINTAINING WEB SITES FOR OTHERS; CREATING, DESIGNING AND MAINTAINING WEB SITES; CREATION AND MAINTENANCE OF WEB SITES FOR OTHERS; COMPUTER AIDED DESIGN FOR OTHERS; COMPUTER AIDED GRAPHIC DESIGN; CREATION, DESIGN, DEVELOPMENT AND MAINTENANCE OF WEB SITES FOR THIRD PARTIES; GRAPHIC DESIGN SERVICES; PROVIDING GRAPHIC AND MULTIMEDIA DESIGN SERVICES FOR THE PURPOSE OF PROMOTING THE GOODS AND SERVICES OF OTHERS (U.S. CLS. 100 AND 101).

FIRST USE 3-21-2011; IN COMMERCE 3-21-2011.
CYNTHIA SLOAN, EXAMINING ATTORNEY

SN 85-275,047. SAN DIEGO ALUMINUM PRODUCTS, INC., CHULA VISTA, CA. FILED 3-23-2011.



NO CLAIM IS MADE TO THE EXCLUSIVE RIGHT TO USE "ALUMINUM", APART FROM THE MARK AS SHOWN.

THE MARK CONSISTS OF THREE STRIPES ON THE UPPER LEFT CORNER, THE LETTERS "A" AND "B" STACKED ON TOP OF THE LETTER "C", AND THE WORDS "ALUMINUM SOLUTIONS" EXTENDING RIGHT FROM THE LETTER "C".

CLASS 35—ADVERTISING AND BUSINESS

FOR TRANSPORTATION LOGISTICS SERVICES, NAMELY, ARRANGING THE TRANSPORTING OF ALUMINUM EXTRUSIONS MANUFACTURED IN A FOREIGN COUNTRY; IMPORT AGENCY SERVICES IN THE FIELD OF ALUMINUM EXTRUSIONS MANUFACTURED IN A FOREIGN COUNTRY (U.S. CLS. 100, 101 AND 102).

FIRST USE 1-1-2010; IN COMMERCE 1-1-2010.

CLASS 39—TRANSPORTATION AND STORAGE

FOR TRANSPORTATION SERVICES, NAMELY, TRANSPORTING ALUMINUM EXTRUSIONS MANUFACTURED IN A FOREIGN COUNTRY (U.S. CLS. 100 AND 105).

FIRST USE 1-1-2010; IN COMMERCE 1-1-2010.
FONG HSU, EXAMINING ATTORNEY

WILLIAM VERHOSEK, EXAMINING ATTORNEY

SN 85-275,248. DWADA, LLC, WILMINGTON, DE. FILED 3-24-2011.

SN 85-275,054. FTEN, INC., LAKEWOOD, CO. FILED 3-23-2011.

VX PROXY

THE MARK CONSISTS OF STANDARD CHARACTERS WITHOUT CLAIM TO ANY PARTICULAR FONT, STYLE, SIZE, OR COLOR.

NO CLAIM IS MADE TO THE EXCLUSIVE RIGHT TO USE "PROXY", APART FROM THE MARK AS SHOWN.

CLASS 36—INSURANCE AND FINANCIAL

FOR FINANCIAL RISK MANAGEMENT (U.S. CLS. 100, 101 AND 102).

FIRST USE 11-1-2010; IN COMMERCE 2-8-2011.

CLASS 42—SCIENTIFIC AND COMPUTER SERVICES

FOR SOFTWARE AS A SERVICE (SAAS) SERVICES FEATURING SOFTWARE FOR USE IN FINANCIAL RISK MANAGEMENT, NAMELY, FOR HIGH SPEED, LOW LATENCY FINANCIAL SECURITIES TRADING (U.S. CLS. 100 AND 101).

FIRST USE 11-1-2010; IN COMMERCE 2-8-2011.
MATTHEW MCDOWELL, EXAMINING ATTORNEY

DWADA

THE MARK CONSISTS OF STANDARD CHARACTERS WITHOUT CLAIM TO ANY PARTICULAR FONT, STYLE, SIZE, OR COLOR.

THE WORDING "DWADA" HAS NO MEANING IN A FOREIGN LANGUAGE.

CLASS 41—EDUCATION AND ENTERTAINMENT

FOR ENTERTAINMENT SERVICES, NAMELY PROVIDING ONLINE ELECTRONIC GAMES; ONLINE JOURNALS, NAMELY BLOGS FEATURING FICTITIOUS AND REAL STORIES OF PERSONAL EVENTS (U.S. CLS. 100, 101 AND 107).

CLASS 42—SCIENTIFIC AND COMPUTER SERVICES

FOR COMPUTER SERVICES, NAMELY, CREATING AN ONLINE COMMUNITY FOR USERS TO SHARE, COMMENT ON AND JUDGE FICTITIOUS AND REAL STORIES OF PERSONAL EVENTS (U.S. CLS. 100 AND 101).

CLASS 45—PERSONAL AND LEGAL SERVICES

FOR ONLINE SOCIAL NETWORKING SERVICES (U.S. CLS. 100 AND 101).

KATHY DE JONGE, EXAMINING ATTORNEY

SN 85-275,126. BARN STORM PICTURES, LLC, ENGLEWOOD, CO. FILED 3-23-2011.

PARANOID PARENTS

THE MARK CONSISTS OF STANDARD CHARACTERS WITHOUT CLAIM TO ANY PARTICULAR FONT, STYLE, SIZE, OR COLOR.

NO CLAIM IS MADE TO THE EXCLUSIVE RIGHT TO USE "PARENTS", APART FROM THE MARK AS SHOWN.

CLASS 35—ADVERTISING AND BUSINESS

FOR ENDORSEMENT SERVICES, NAMELY, PROMOTING THE GOODS AND SERVICES OF OTHERS (U.S. CLS. 100, 101 AND 102).

FIRST USE 1-0-2008; IN COMMERCE 1-0-2008.

SN 85-275,331. GREENLIGHT BIOFUELS HOLDINGS, LLC, DBA GREENLIGHT BIOFUELS, CHARLOTTESVILLE, VA. FILED 3-24-2011.

Clean. Green. Reliable.

THE MARK CONSISTS OF STANDARD CHARACTERS WITHOUT CLAIM TO ANY PARTICULAR FONT, STYLE, SIZE, OR COLOR.

NO CLAIM IS MADE TO THE EXCLUSIVE RIGHT TO USE "CLEAN" OR "GREEN", APART FROM THE MARK AS SHOWN.

CLASS 43—HOTEL AND RESTAURANT SERVICES

FOR CONSULTATION SERVICES IN THE FIELD OF CHILD CARE (U.S. CLS. 100 AND 101).

FIRST USE 1-8-2008; IN COMMERCE 1-8-2008.

CLASS 37—CONSTRUCTION AND REPAIR

FOR RECYCLING SERVICES, NAMELY, COLLECTING USED FAT OR VEGETABLE OIL OR COOKING OIL FOR PURPOSES OF CONVERTING IT TO BIOFUEL OR BLENDING IT WITH PETROLEUM DIESEL TO CREATE BIODIESEL FUEL (U.S. CLS. 100, 103 AND 106).

FIRST USE 10-15-2007; IN COMMERCE 11-1-2007.

CLASS 40—MATERIAL TREATMENT

FOR PRODUCTION, TREATMENT AND REFINEMENT OF FUEL, DIESEL FUEL, BIOFUEL AND BIO-DIESEL FUEL FOR OTHERS (U.S. CLS. 100, 103 AND 106).

FIRST USE 10-15-2007; IN COMMERCE 11-1-2007.
GRETCHEN ULRICH, EXAMINING ATTORNEY

SN 85-275,584. THE JIM HENSON COMPANY, INC., LOS ANGELES, CA. FILED 3-24-2011.



SN 85-275,445. R360 ENVIRONMENTAL SOLUTIONS, INC., HOUSTON, TX. FILED 3-24-2011.

R360 Environmental Solutions

THE MARK CONSISTS OF STANDARD CHARACTERS WITHOUT CLAIM TO ANY PARTICULAR FONT, STYLE, SIZE, OR COLOR.

NO CLAIM IS MADE TO THE EXCLUSIVE RIGHT TO USE "ENVIRONMENTAL SOLUTIONS", APART FROM THE MARK AS SHOWN.

CLASS 37—CONSTRUCTION AND REPAIR

FOR WASTE OIL COLLECTION FOR RECYCLING (U.S. CLS. 100, 103 AND 106).

FIRST USE 0-0-2010; IN COMMERCE 0-0-2010.

CLASS 39—TRANSPORTATION AND STORAGE

FOR RECYCLED WATER DISTRIBUTION SERVICES FOR OTHERS (U.S. CLS. 100 AND 105).

FIRST USE 0-0-2010; IN COMMERCE 0-0-2010.

CLASS 40—MATERIAL TREATMENT

FOR ENVIRONMENTAL REMEDIATION SERVICES, NAMELY, WASTE AND WATER TREATMENT SERVICES; PROVISION OF INFORMATION, ADVICE AND CONSULTANCY IN RELATION TO THE PRODUCTION OF ENERGY, AND THE TREATMENT, MANAGEMENT, RECYCLING, TRANSFORMATION AND INCINERATION OF WASTE; RECYCLING; RECYCLING OF WASTE; SUSTAINABLE ON-SITE WATER RECYCLING AND WASTEWATER TREATMENT SERVICES; TREATMENT OF WASTE WATER; WASTE WATER REPROCESSING; WASTE WATER TREATMENT SERVICES; WASTE WATER TREATMENT SERVICES FOR INDUSTRIAL PURPOSES; WATER RECYCLING AND DESALINATION SERVICES (U.S. CLS. 100, 103 AND 106).

FIRST USE 0-0-2010; IN COMMERCE 0-0-2010.

DEIRDRE ROBERTSON, EXAMINING ATTORNEY

OWNER OF U.S. REG. NOS. 1,113,706, 3,962,098 AND OTHERS.

THE NAME "JIM HENSON" DOES NOT IDENTIFY A LIVING INDIVIDUAL.

CLASS 9—ELECTRICAL AND SCIENTIFIC APPARATUS

FOR AUDIOVISUAL RECORDINGS FEATURING CHILDREN'S TELEVISION SHOWS; DVDS FEATURING CHILDREN'S TELEVISION SHOWS; SOUND RECORDINGS FEATURING CHILDREN'S TELEVISION SHOWS; DOWNLOADABLE SOUND RECORDINGS FEATURING CHILDREN'S TELEVISION SHOWS; DOWNLOADABLE AUDIOVISUAL RECORDINGS FEATURING CHILDREN'S TELEVISION SHOWS (U.S. CLS. 21, 23, 26, 36 AND 38).

FIRST USE 0-0-2009; IN COMMERCE 0-0-2009.

CLASS 16—PAPER GOODS AND PRINTED MATTER

FOR PRINTED MATERIALS, NAMELY, CHILDREN'S STORYBOOKS; POSTERS, STICKERS AND GREETING CARDS; PAPER PARTY SUPPLIES, NAMELY, METALLIC PAPER PARTY DECORATIONS, PAPER PARTY BAGS, PAPER PARTY DECORATIONS (U.S. CLS. 2, 5, 22, 23, 29, 37, 38 AND 50).

FIRST USE 0-0-2010; IN COMMERCE 0-0-2010.

CLASS 25—CLOTHING

FOR CLOTHING, NAMELY, SHIRTS, SLEEPWEAR (U.S. CLS. 22 AND 39).

FIRST USE 0-0-2010; IN COMMERCE 0-0-2010.

CLASS 28—TOYS AND SPORTING GOODS

FOR TOYS, NAMELY, PRESCHOOL LEARNING AND DEVELOPMENT TOYS, HOBBY CRAFT KITS FOR SCIENCE PROJECTS AND EXPERIMENTS, PLUSH TOYS AND PLUSH DOLLS; SCIENCE AND NATURE TOYS, PLAYTHINGS AND ACTIVITY KITS, NAMELY, TOY MICROSCOPES, CHILD-ACTIVITY INSECT VIEWERS, OUTDOOR EXPLORATION TOYS, SCIENCE-THEMED ACTIVITY AND PLAY SETS, CHILD-ACTIVITY PLANT GROWING KITS, CHILD-ACTIVITY BIOLOGY SETS, CHILD-ACTIVITY EARTH SCIENCE SETS, CHILD-ACTIVITY PHYSICS SETS; GAMES, NAMELY, PUZZLES (U.S. CLS. 22, 23, 38 AND 50).

FIRST USE 0-0-2009; IN COMMERCE 0-0-2009.

CLASS 41—EDUCATION AND ENTERTAINMENT

FOR ENTERTAINMENT SERVICES, NAMELY, SERIES OF TELEVISION PROGRAMS IN THE FIELDS OF CHILDREN'S ENTERTAINMENT AND MUSIC AND ANIMATED TELEVISION PROGRAMS IN THE FIELDS OF CHILDREN'S ENTERTAINMENT AND MUSIC; A SERIES OF CHILDREN'S TELEVISION PROGRAMS; ENTERTAINMENT SERVICES, NAMELY, PROVIDING NON-DOWNLOADABLE AUDIOVISUAL RECORDINGS, PRERECORDED TELEVISION SHOW EPISODES, AND VIDEO CLIPS, ALL FEATURING CHILDREN'S ENTERTAINMENT AND MUSIC AND ALL ONLINE VIA A GLOBAL COMPUTER NETWORK (U.S. CLS. 100, 101 AND 107).

FIRST USE 0-0-2008; IN COMMERCE 0-0-2008.
JUDITH HELFMAN, EXAMINING ATTORNEY

SN 85-275,608. PLAYGROUND PROFESSIONALS, LLC, ASHTON, ID. FILED 3-24-2011.

PGP

THE MARK CONSISTS OF STANDARD CHARACTERS WITHOUT CLAIM TO ANY PARTICULAR FONT, STYLE, SIZE, OR COLOR.

CLASS 35—ADVERTISING AND BUSINESS

FOR PROVIDING AN ONLINE DIRECTORY INFORMATION SERVICE FEATURING INFORMATION REGARDING PLAYGROUND PROFESSIONALS; PROVIDING CONSUMER INFORMATION ONLINE RELATING TO PLAYING, PLAYGROUND, AND PLAYGROUND EQUIPMENT TERMS (U.S. CLS. 100, 101 AND 102).

FIRST USE 3-1-2011; IN COMMERCE 3-1-2011.

CLASS 41—EDUCATION AND ENTERTAINMENT

FOR PROVIDING ENCYCLOPEDIA AND EDUCATIONAL INFORMATION ONLINE RELATING TO PLAYING, PLAYGROUND, AND PLAYGROUND EQUIPMENT TERMS (U.S. CLS. 100, 101 AND 107).

FIRST USE 11-20-2010; IN COMMERCE 11-20-2010.
HANNO RITNER, EXAMINING ATTORNEY

SN 85-275,609. DASS, BRIAN, SECAUCUS, NJ. FILED 3-24-2011.

StyleHotels

THE MARK CONSISTS OF STANDARD CHARACTERS WITHOUT CLAIM TO ANY PARTICULAR FONT, STYLE, SIZE, OR COLOR.

CLASS 35—ADVERTISING AND BUSINESS

FOR ADVERTISING AND MARKETING SERVICES PROVIDED BY MEANS OF INDIRECT METHODS OF MARKETING COMMUNICATIONS, NAMELY, SOCIAL MEDIA, SEARCH ENGINE MARKETING, INQUIRY MARKETING, INTERNET MARKETING, MOBILE MARKETING, BLOGGING AND OTHER FORMS OF PASSIVE, SHARABLE OR VIRAL COMMUNICATIONS CHANNELS (U.S. CLS. 100, 101 AND 102).

FIRST USE 6-4-2004; IN COMMERCE 6-4-2004.

CLASS 43—HOTEL AND RESTAURANT SERVICES

FOR CONSULTING SERVICES IN THE FIELD OF HOSPITALITY; TRAVEL AGENCY SERVICES, NAMELY, MAKING RESERVATIONS AND BOOKING FOR TEMPORARY LODGING FOR OTHER TRAVEL AGENCIES, TRAVEL SUPPLIERS, AND CORPORATIONS, VIA ON-LINE COMPUTER NETWORKS (U.S. CLS. 100 AND 101).

FIRST USE 6-4-2004; IN COMMERCE 6-4-2004.
PAM WILLIS, EXAMINING ATTORNEY

SN 85-275,623. SHEPARD, DAVID, BONSALE, CA. FILED 3-24-2011.



THE MARK CONSISTS OF TWO STYLIZED FACES WEARING SUNGLASSES ABOVE THE STYLIZED TEXT "GO BRO".

CLASS 16—PAPER GOODS AND PRINTED MATTER

FOR DECALS (U.S. CLS. 2, 5, 22, 23, 29, 37, 38 AND 50).

CLASS 25—CLOTHING

FOR HATS; SHIRTS (U.S. CLS. 22 AND 39).
ALYSSA STEEL, EXAMINING ATTORNEY

SN 85-275,700. WELLO, LLC, DALLAS, TX. FILED 3-24-2011.

WELLO

THE MARK CONSISTS OF STANDARD CHARACTERS WITHOUT CLAIM TO ANY PARTICULAR FONT, STYLE, SIZE, OR COLOR.

CLASS 5—PHARMACEUTICALS

FOR ANTI-BACTERIAL LIQUID COMPOSITIONS IN THE NATURE OF HAND SANITIZING PREPARATIONS (U.S. CLS. 6, 18, 44, 46, 51 AND 52).

CLASS 9—ELECTRICAL AND SCIENTIFIC APPARATUS

FOR TEMPERATURE SENSORS (U.S. CLS. 21, 23, 26, 36 AND 38).
WILLIAM ROSSMAN, EXAMINING ATTORNEY

SN 85-275,739. PREFERRED OFFICE PROPERTIES, LLC, DBA CARR WORKPLACES, WASHINGTON, DC. FILED 3-24-2011.

OWNER OF U.S. REG. NOS. 3,844,307 AND 3,890,189.
NO CLAIM IS MADE TO THE EXCLUSIVE RIGHT TO USE "WORKPLACES", APART FROM THE MARK AS SHOWN.

THE MARK CONSISTS OF THE WORDS "CARR WORKPLACES" WITH A STYLIZED LETTER "P" ABOVE A GRAPHIC OF AN ARC THAT IS CURVING UPWARDS.

CLASS 35—ADVERTISING AND BUSINESS

FOR OFFICE ADMINISTRATION SERVICES (U.S. CLS. 100, 101 AND 102).
FIRST USE 3-1-2011; IN COMMERCE 3-1-2011.

CLASS 36—INSURANCE AND FINANCIAL

FOR REAL ESTATE LISTING; REAL ESTATE MANAGEMENT SERVICES; RENTAL OF OFFICE SPACE (U.S. CLS. 100, 101 AND 102).

FIRST USE 3-1-2011; IN COMMERCE 3-1-2011.
CHARLES L. JENKINS, EXAMINING ATTORNEY

SN 85-275,765. MARK A. MITCHELL, SAN CLEMENTE, CA. FILED 3-24-2011.

1 LESS THAN 2

THE MARK CONSISTS OF STANDARD CHARACTERS WITHOUT CLAIM TO ANY PARTICULAR FONT, STYLE, SIZE, OR COLOR.

CLASS 18—LEATHER GOODS

FOR BACKPACKS; KNAPSACKS; FANNY PACKS; GYM BAGS; DUFFLE BAGS; PURSES (U.S. CLS. 1, 2, 3, 22 AND 41).

CLASS 21—HOUSEWARES AND GLASS

FOR PLASTIC WATER BOTTLES SOLD EMPTY; PERSONAL FLUID HYDRATION PACK SYSTEMS COMPRISING A FLUID RESERVOIR, A DELIVERY TUBE, A MOUTHPIECE AND A CARRYING PACK (U.S. CLS. 2, 13, 23, 29, 30, 33, 40 AND 50).

DAVID YONTEF, EXAMINING ATTORNEY

SN 85-275,830. HOLLANDER HOME FASHIONS, LLC, BOCA RATON, FL. FILED 3-24-2011.

TYOT

THE MARK CONSISTS OF STANDARD CHARACTERS WITHOUT CLAIM TO ANY PARTICULAR FONT, STYLE, SIZE, OR COLOR.

CLASS 20—FURNITURE AND ARTICLES NOT OTHERWISE CLASSIFIED

FOR PILLOWS; MATTRESS TOPPERS; FEATHER BEDS (U.S. CLS. 2, 13, 22, 25, 32 AND 50).

CLASS 24—FABRICS

FOR MATTRESS PADS; COMFORTERS; BED BLANKETS (U.S. CLS. 42 AND 50).
KELLY BOULTON, EXAMINING ATTORNEY

SN 85-275,854. HOLLANDER HOME FASHIONS, LLC, BOCA RATON, FL. FILED 3-24-2011.

THE YOUTH OF TODAY

THE MARK CONSISTS OF STANDARD CHARACTERS WITHOUT CLAIM TO ANY PARTICULAR FONT, STYLE, SIZE, OR COLOR.

CLASS 20—FURNITURE AND ARTICLES NOT OTHERWISE CLASSIFIED

FOR PILLOWS; MATTRESS TOPPERS; FEATHER BEDS (U.S. CLS. 2, 13, 22, 25, 32 AND 50).

CLASS 24—FABRICS

FOR MATTRESS PADS; COMFORTERS; BED BLANKETS (U.S. CLS. 42 AND 50).
KELLY BOULTON, EXAMINING ATTORNEY

SN 85-275,859. PT'S COFFEE ROASTING CO., INC., TOPEKA, KS. FILED 3-24-2011.

SN 85-276,230. KAGAN, ANITA S., RANDOLPH, MA. FILED 3-24-2011.

PT's Coffee Roasting Co.

THE MARK CONSISTS OF STANDARD CHARACTERS WITHOUT CLAIM TO ANY PARTICULAR FONT, STYLE, SIZE, OR COLOR.

NO CLAIM IS MADE TO THE EXCLUSIVE RIGHT TO USE "COFFEE ROASTING CO.", APART FROM THE MARK AS SHOWN.

CLASS 30—STAPLE FOODS

FOR COFFEE; COFFEE BEANS; COFFEE-BASED BEVERAGES (U.S. CL. 46).
FIRST USE 1-1-1993; IN COMMERCE 1-1-1993.

CLASS 40—MATERIAL TREATMENT

FOR COFFEE ROASTING AND PROCESSING (U.S. CLS. 100, 103 AND 106).
FIRST USE 1-1-1997; IN COMMERCE 1-1-1997.

CLASS 43—HOTEL AND RESTAURANT SERVICES

FOR COFFEE BARS (U.S. CLS. 100 AND 101).
FIRST USE 1-1-1993; IN COMMERCE 1-1-1993.
H. M. FISHER, EXAMINING ATTORNEY

SN 85-275,871. BAD GIRL VENTURES, LLC, CINCINNATI, OH. FILED 3-24-2011.

BAD GIRL VENTURES

THE MARK CONSISTS OF STANDARD CHARACTERS WITHOUT CLAIM TO ANY PARTICULAR FONT, STYLE, SIZE, OR COLOR.

NO CLAIM IS MADE TO THE EXCLUSIVE RIGHT TO USE "VENTURES", APART FROM THE MARK AS SHOWN.

CLASS 35—ADVERTISING AND BUSINESS

FOR MATCHING BORROWERS WITH POTENTIAL LENDERS IN THE FIELD OF BUSINESS START-UPS AND EMERGING BUSINESSES; BUSINESS DEVELOPMENT SERVICES, NAMELY, PROVIDING START-UP SUPPORT FOR THE BUSINESSES OF OTHERS (U.S. CLS. 100, 101 AND 102).
FIRST USE 6-30-2010; IN COMMERCE 6-30-2010.

CLASS 36—INSURANCE AND FINANCIAL

FOR VENTURE-CAPITAL SERVICES, NAMELY, PROVIDING FINANCING TO EMERGING AND START-UP COMPANIES; COMMERCIAL LENDING SERVICES; LENDING CONSULTANT SERVICES (U.S. CLS. 100, 101 AND 102).

FIRST USE 6-30-2010; IN COMMERCE 6-30-2010.
SAMUEL E. SHARPER JR., EXAMINING ATTORNEY

Living on The Next

THE MARK CONSISTS OF STANDARD CHARACTERS WITHOUT CLAIM TO ANY PARTICULAR FONT, STYLE, SIZE, OR COLOR.

CLASS 35—ADVERTISING AND BUSINESS

FOR DEVELOPMENT OF MARKETING STRATEGIES AND CONCEPTS (U.S. CLS. 100, 101 AND 102).

CLASS 41—EDUCATION AND ENTERTAINMENT

FOR ON-LINE JOURNALS, NAMELY, BLOGS IN THE FIELD OF DEVELOPMENT OF MARKETING STRATEGIES AND CONCEPTS, LIFESTYLE, DATING, RELATIONSHIPS, SOCIAL COMMENTARY, GENERAL TOPICAL ISSUES AND NEWS OF CURRENT EVENTS (U.S. CLS. 100, 101 AND 107).

JOHN WILKE, EXAMINING ATTORNEY

SN 85-276,274. SUN-RYPE PRODUCTS LTD., KELOWNA, BC, CANADA, FILED 3-24-2011.



OWNER OF U.S. REG. NOS. 3,571,726, 3,909,677 AND OTHERS.

NO CLAIM IS MADE TO THE EXCLUSIVE RIGHT TO USE 100% REAL FRUIT, APART FROM THE MARK AS SHOWN.

THE MARK CONSISTS OF A FANCIFUL SUNBURST DESIGN ABOVE THE WORDING "SUNRYPE", WHICH IS ALL ABOVE THE WORDING "100% REAL FRUIT GOODNESS".

CLASS 29—MEATS AND PROCESSED FOODS

FOR FOOD PRODUCTS, NAMELY, FRUIT SNACKS, GRANOLA-BASED SNACK BARS, FRUIT-BASED SNACK BARS, GRANOLA AND FRUIT-BASED SNACK BARS WITH GRAINS, AND FRUIT-BASED SNACK BARS WITH SEEDS; AND APPLE SAUCE (U.S. CL. 46).

CLASS 32—LIGHT BEVERAGES

FOR FOOD PRODUCTS, NAMELY, PURE FRUIT JUICES, FRUIT JUICE BEVERAGES, FRUIT JUICES FORTIFIED WITH MULTI-VITAMINS, NON-ALCOHOLIC FRUIT JUICE COMBOS, NON-ALCOHOLIC FRUIT BEVERAGES, NON-ALCOHOLIC FRUIT JUICE BLENDS, FRUIT AND VEGETABLE JUICES, FRUIT-FLAVORED BEVERAGES AND 100 PERCENT FRUIT JUICES; FRUIT SMOOTHIES (U.S. CLS. 45, 46 AND 48).

HEATHER SAPP, EXAMINING ATTORNEY

SN 85-276,313. PALOMA'S NEST, LLC, AUSTIN, TX. FILED 3-24-2011.

SN 85-276,356. GRIP-TECH, LLC, ALAMO, CA. FILED 3-24-2011.

PALOMA'S NEST

THE MARK CONSISTS OF STANDARD CHARACTERS WITHOUT CLAIM TO ANY PARTICULAR FONT, STYLE, SIZE, OR COLOR.

OWNER OF U.S. REG. NO. 3,744,593.
THE ENGLISH TRANSLATION OF "PALOMA" IN THE MARK IS "DOVE".

CLASS 16—PAPER GOODS AND PRINTED MATTER

FOR (BASED ON USE IN COMMERCE) PACKAGING BAGS OF TEXTILE MATERIAL, NAMELY, FABRIC GIFT BAGS FOR PACKAGING AND HOLDING GIFTS (U.S. CLS. 2, 5, 22, 23, 29, 37, 38 AND 50).

FIRST USE 2-1-2008; IN COMMERCE 2-1-2008.

CLASS 20—FURNITURE AND ARTICLES NOT OTHERWISE CLASSIFIED

FOR (BASED ON USE IN COMMERCE) BEDROOM FURNITURE; CUSTOM FURNITURE; DECORATIVE BOXES MADE OF WOOD; FIGURES OF WOOD; FIGURINES OF WOOD; FURNITURE FOR HOUSE, OFFICE AND GARDEN; FURNITURE MADE FROM WOOD OR SUBSTITUTES FOR WOOD; LETTER BOXES OF WOOD; LIVING ROOM FURNITURE; METAL FURNITURE; ORNAMENTS OF WOOD; PICTURE FRAMES; WALL PLAQUES MADE OF WOOD; WOOD CARVINGS; WORKS OF ART OF WOOD, WAX, PLASTER AND PLASTIC (U.S. CLS. 2, 13, 22, 25, 32 AND 50).

FIRST USE 1-1-2008; IN COMMERCE 1-1-2008.

CLASS 24—FABRICS

FOR (BASED ON INTENT TO USE) BATH LINEN; BED AND TABLE LINEN, WALL HANGINGS OF TEXTILE; FABRIC WINDOW COVERINGS AND TREATMENTS, NAMELY, CURTAINS, DRAPERIES, SHEERS, SWAGS AND VALANCES; FABRIC WINDOW COVERINGS AND TREATMENTS, NAMELY, CURTAINS, DRAPERIES, SHEERS, SWAGS AND VALANCES; FURNISHING AND UPHOLSTERY FABRICS; HOUSEHOLD LINEN; INTERIOR DECORATION FABRICS (U.S. CLS. 42 AND 50).

CLASS 26—FANCY GOODS

FOR (BASED ON USE IN COMMERCE) ORNAMENTAL RIBBONS MADE OF TEXTILES; RIBBONS; RIBBONS OF TEXTILE FOR PACKAGING AND FOR WRAPPING (U.S. CLS. 37, 39, 40, 42 AND 50).

FIRST USE 2-1-2008; IN COMMERCE 2-1-2008.

CLASS 28—TOYS AND SPORTING GOODS

FOR (BASED ON USE IN COMMERCE) CHRISTMAS STOCKINGS; CHRISTMAS TREE ORNAMENTS AND DECORATIONS; CHRISTMAS TREE SKIRTS; COLLECTIBLE TOY FIGURES; INFANT TOYS; PULL TOYS; TOY ANIMALS; TOY FIGURES; TOY TRAINS AND PARTS AND ACCESSORIES THEREFOR; TOY VEHICLES (U.S. CLS. 22, 23, 38 AND 50).

FIRST USE 1-1-2008; IN COMMERCE 1-1-2008.
MICHAEL TANNER, EXAMINING ATTORNEY



OWNER OF U.S. REG. NOS. 3,841,293 AND 3,856,111.
THE COLOR(S) ORANGE, LIGHT GREY AND DARK GREY IS/ARE CLAIMED AS A FEATURE OF THE MARK.
THE MARK CONSISTS OF THE TERM "TEGS" IN DARK GREY, AND A DESIGN OF THREE ROWS OF THREE CIRCLES WITH THE FIVE CIRCLES IN THE TOP AND MIDDLE VERTICAL ROWS BEING ORANGE TO FORM THE LETTER "T" AND THE REMAINING FOUR CIRCLES LIGHT GREY.

CLASS 9—ELECTRICAL AND SCIENTIFIC APPARATUS

FOR PROTECTIVE GLOVES FOR MILITARY, LAW ENFORCEMENT, FIRST RESPONDERS AND FIRE FIGHTERS (U.S. CLS. 21, 23, 26, 36 AND 38).

CLASS 13—FIREARMS

FOR FIREARM CASES AND SLINGS (U.S. CLS. 2 AND 9).
JOHN DWYER, EXAMINING ATTORNEY

SN 85-276,363. SHINN, ROBERT, GRAYSLAKE, IL. AND ROBERT, DANA, GRAYSLAKE, IL. FILED 3-24-2011.

Intelligent IT. Business Evolved.

THE MARK CONSISTS OF STANDARD CHARACTERS WITHOUT CLAIM TO ANY PARTICULAR FONT, STYLE, SIZE, OR COLOR.

NO CLAIM IS MADE TO THE EXCLUSIVE RIGHT TO USE "IT", APART FROM THE MARK AS SHOWN.

CLASS 35—ADVERTISING AND BUSINESS

FOR BUSINESS MANAGEMENT CONSULTING; MARKETING CONSULTING (U.S. CLS. 100, 101 AND 102).

FIRST USE 12-1-2008; IN COMMERCE 12-1-2009.

CLASS 42—SCIENTIFIC AND COMPUTER SERVICES

FOR CONSULTING IN THE FIELD OF IT PROJECT MANAGEMENT; IT CONSULTING SERVICES; TESTING, ANALYSIS, AND EVALUATION OF THE KNOWLEDGE, SKILLS AND ABILITIES OF OTHERS FOR THE PURPOSE OF CERTIFICATION AND RE-CERTIFICATION IN THE FIELD OF CLOUD COMPUTING (U.S. CLS. 100 AND 101).

FIRST USE 12-1-2008; IN COMMERCE 12-1-2009.
LEIGH CAROLINE CASE, EXAMINING ATTORNEY

SN 85-276,415. YOTZERET PUBLISHING, INCORPORATED, SAINT PAUL, MN. FILED 3-24-2011.

Yotzeret

THE MARK CONSISTS OF STANDARD CHARACTERS WITHOUT CLAIM TO ANY PARTICULAR FONT, STYLE, SIZE, OR COLOR.

THE ENGLISH TRANSLATION OF "YOTZERET" IN THE MARK IS "SHE CREATES".

CLASS 9—ELECTRICAL AND SCIENTIFIC APPARATUS

FOR AUDIO BOOKS IN THE FIELD OF JUDAISM; AUDIO BOOKS IN THE NATURE OF NOVELS; DOWNLOADABLE MP3 FILES, MP3 RECORDINGS, ON-LINE DISCUSSION BOARDS, WEBCASTS, WEBINARS AND PODCASTS FEATURING MUSIC, AUDIO BOOKS IN THE FIELD OF JUDAISM, AND NEWS BROADCASTS; ELECTRONIC PUBLICATIONS, NAMELY, BOOKS FEATURING JEWISH THEMES, CHARACTERS, INFORMATION, LANGUAGE, OR VALUES RECORDED ON COMPUTER MEDIA; NON-FICTION AUDIO BOOKS ON A VARIETY OF TOPICS (U.S. CLS. 21, 23, 26, 36 AND 38).

CLASS 16—PAPER GOODS AND PRINTED MATTER

FOR A SERIES OF BOOKS AND WRITTEN ARTICLES IN THE FIELD OF JUDAISM; A SERIES OF BOOKS, WRITTEN ARTICLES, HANDOUTS AND WORKSHEETS IN THE FIELD OF JUDAISM; BOOKS IN THE FIELD OF JUDAISM; CHILDREN'S ACTIVITY BOOKS; CHILDREN'S BOOKS; CHILDREN'S INTERACTIVE EDUCATIONAL BOOKS; COFFEE TABLE BOOKS FEATURING JEWISH THEMES, INFORMATION, LANGUAGE, OR VALUES; COLORING BOOKS; COMIC BOOKS; COMMEMORATIVE BOOKS FEATURING JEWISH THEMES, CHARACTERS, INFORMATION, LANGUAGE, OR VALUES; COMPOSITION BOOKS; COOK BOOKS; COPY BOOKS; EDUCATIONAL BOOKS FEATURING JEWISH THEMES, CHARACTERS, INFORMATION, LANGUAGE, OR VALUES; EDUCATIONAL KITS SOLD AS A UNIT IN THE FIELD OF JUDAISM CONSISTING PRIMARILY OF EDUCATIONAL BOOKS AND ALSO INCLUDING DVDS AND T-SHIRTS; EDUCATIONAL KITS SOLD AS A UNIT IN THE FIELD OF JUDAISM CONSISTING PRIMARILY OF EDUCATIONAL BOOKS, FLASH CARDS AND WORKSHEETS, AND ALSO INCLUDING AN EDUCATIONAL DVD; EDUCATIONAL KITS SOLD AS A UNIT IN THE FIELD OF JUDAISM CONSISTING PRIMARILY OF BOOKS AND ALSO INCLUDING DVDS; EDUCATIONAL PUBLICATIONS, NAMELY, EDUCATIONAL LEARNING CARDS, FLASH CARDS, ACTIVITY CARDS, WORKBOOKS, TEXTBOOKS, ACTIVITY BOOKS, STORY BOOKS, PUZZLE BOOKS, PRINTED PUZZLES, TEACHER GUIDES, MANUALS, POSTERS AND EDUCATIONAL BOOKLETS IN THE FIELD OF JUDAISM; EDUCATIONAL PUBLICATIONS, NAMELY, BOOKS IN THE FIELDS OF JUDAISM; FLIP BOOKS; GIFT BOOKS FEATURING JEWISH THEMES, CHARACTERS, INFORMATION, LANGUAGE, OR VALUES; NON-FICTION BOOKS ON A VARIETY OF TOPICS; NON-FICTION BOOKS ON A VARIETY OF TOPICS; PICTURE BOOKS; PRAYER BOOKS; PRINTED MATTER, NAMELY, PAPER SIGNS, BOOKS, MANUALS, CURRICULUM, NEWSLETTERS, INFORMATIONAL CARDS AND BROCHURES IN THE FIELD OF JUDAISM; PRINTED MUSIC BOOKS; PRINTED PAMPHLETS, BROCHURES, MANUALS, BOOKS, BOOKLETS, LEAFLETS, FLYERS, INFORMATIONAL SHEETS AND NEWSLETTERS, ADHESIVE BACKED STICKERS, AND KITS COMPRISING ONE OR MORE OF THE FOREGOING MATERIALS IN THE FIELD OF JUDAISM; PUBLICATIONS, NAMELY, BOOKS IN THE FIELDS OF JUDAISM AND HEBREW; RECIPE BOOKS; REFERENCE BOOKS IN THE FIELD OF JUDAISM; RELIGIOUS BOOKS; RESOURCE BOOKS

IN THE FIELD OF JUDAISM; SCHOLARLY BOOKS ON VARIOUS TOPICS, NAMELY, JEWISH THEMES, CHARACTERS, INFORMATION, LANGUAGE, OR VALUES; SERIES OF FICTION AND NON-FICTION BOOKS ON A VARIETY OF TOPICS; SERIES OF FICTION AND NON-FICTION BOOKS ON A VARIETY OF TOPICS; SERIES OF FICTION BOOKS; SERIES OF FICTION WORKS, NAMELY, NOVELS AND BOOKS; SERIES OF NON-FICTION BOOKS IN THE FIELD OF JUDAISM; SONG BOOKS; STORY BOOKS; TALKING CHILDREN'S BOOKS; TRAVEL BOOKS; WIREBOUND BOOKS (U.S. CLS. 2, 5, 22, 23, 29, 37, 38 AND 50).

CLASS 41—EDUCATION AND ENTERTAINMENT

FOR BOOK AND REVIEW PUBLISHING; BOOK LOANING; BOOK PUBLISHING; BOOK RENTAL; CHARITABLE SERVICES, NAMELY, PROVIDING BOOKS TO PEOPLE; CHARITABLE SERVICES, NAMELY, PROVIDING BOOKS TO ADULTS AND CHILDREN IN NEED; LENDING OF BOOKS AND OTHER PUBLICATIONS; LENDING OF BOOKS AND PERIODICALS; MULTIMEDIA PUBLISHING OF BOOKS, MAGAZINES, JOURNALS, SOFTWARE, GAMES, MUSIC, AND ELECTRONIC PUBLICATIONS; ONLINE ELECTRONIC PUBLISHING OF BOOKS AND PERIODICALS; PROVIDING A WEBSITE FEATURING NON-DOWNLOADABLE PUBLICATIONS IN THE NATURE OF BOOKS IN THE FIELD OF JUDAISM; PROVIDING A WEBSITE FEATURING RESOURCES, NAMELY, NON-DOWNLOADABLE PUBLICATIONS IN THE NATURE OF BOOKS IN THE FIELD OF JUDAISM; PROVIDING ON-LINE PUBLICATIONS IN THE NATURE OF AN E-BOOK IN THE FIELD OF JUDAISM; PUBLICATION OF BOOKS; PUBLICATION OF BOOKS, MAGAZINES, ALMANACS AND JOURNALS; PUBLICATION OF BOOKS, OF MAGAZINES, OF JOURNALS, OF NEWSPAPERS, OF PERIODICALS, OF CATALOGS, OF BROCHURES; PUBLICATION OF BOOKS, REVIEWS; PUBLICATION OF TEXT BOOKS; PUBLICATION OF TEXTS, BOOKS, JOURNALS; PUBLICATION OF TEXTS, BOOKS, MAGAZINES AND OTHER PRINTED MATTER; PUBLICATION OF BOOKS; PUBLISHING OF BOOKS AND REVIEWS; PUBLISHING OF BOOKS, E-BOOKS, AUDIO BOOKS, MUSIC AND ILLUSTRATIONS; PUBLISHING OF BOOKS, MAGAZINES (U.S. CLS. 100, 101 AND 107).

GENE MACIOL, EXAMINING ATTORNEY

SN 85-276,576. AMERICANS FOR PROSPERITY, ARLINGTON, VA. FILED 3-25-2011.

KEEP 'EM HONEST

THE MARK CONSISTS OF STANDARD CHARACTERS WITHOUT CLAIM TO ANY PARTICULAR FONT, STYLE, SIZE, OR COLOR.

CLASS 35—ADVERTISING AND BUSINESS

FOR ASSOCIATION SERVICES, NAMELY, PROMOTING THE ECONOMIC INTERESTS OF U.S. CITIZENS, PROMOTING INTEREST IN PUBLIC AWARENESS OF ECONOMIC ISSUES, AND PROMOTING INTEREST IN AND PUBLIC AWARENESS OF THE NEED FOR MORE EFFICIENT GOVERNMENT (U.S. CLS. 100, 101 AND 102).

FIRST USE 10-22-2010; IN COMMERCE 10-22-2010.

CLASS 36—INSURANCE AND FINANCIAL

FOR FUNDRAISING SERVICES, NAMELY, RAISING FUNDS TO PROMOTE THE ECONOMIC INTERESTS OF U.S. CITIZENS, TO PROMOTE PUBLIC AWARENESS OF ECONOMIC ISSUES, AND TO PROMOTE THE NEED FOR MORE EFFICIENT GOVERNMENT (U.S. CLS. 100, 101 AND 102).

FIRST USE 10-22-2010; IN COMMERCE 10-22-2010.
PAUL F. GAST, EXAMINING ATTORNEY

SN 85-276,770. WELLS, DUGALD, DBA CUBA CRUISE, WATERDOWN, ONTARIO, CANADA, FILED 3-25-2011.



NO CLAIM IS MADE TO THE EXCLUSIVE RIGHT TO USE "CUBA CRUISE", APART FROM THE MARK AS SHOWN.

THE COLOR(S) BLUE, ORANGE, YELLOW IS/ARE CLAIMED AS A FEATURE OF THE MARK.

THE MARK CONSISTS OF A STYLIZED ORANGE AND YELLOW DANCING SUN-SHAPED FLOWER OUTLINED IN BLUE THAT SITS CENTERED ABOVE THE WORDING "CUBA CRUISE". THE WORDS "CUBA CRUISE" APPEAR IN A BLEND OF LIGHT BLUE TO DARK BLUE REPRESENTING A HORIZON AND OCEAN AND ARE A SPECIFIC UNIQUE DESIGNED FONT.

LA PADRONA

THE MARK CONSISTS OF STANDARD CHARACTERS WITHOUT CLAIM TO ANY PARTICULAR FONT, STYLE, SIZE, OR COLOR.

THE ENGLISH TRANSLATION OF "LA PADRONA" IN THE MARK IS "THE OWNER" OR "THE LANDLADY".

CLASS 31—NATURAL AGRICULTURAL PRODUCTS

FOR FRESH GRAPES FOR WINEMAKING; FRESH WINE GRAPES (U.S. CLS. 1 AND 46).

CLASS 33—WINES AND SPIRITS

FOR WINES (U.S. CLS. 47 AND 49).
MATTHEW MCDOWELL, EXAMINING ATTORNEY

CLASS 39—TRANSPORTATION AND STORAGE

FOR BOAT CRUISES; CONDUCTING SIGHTSEEING TOURS BY BOAT; COORDINATING TRAVEL ARRANGEMENTS FOR INDIVIDUALS AND FOR GROUPS; CRUISE SHIP SERVICES; ESCORTING OF TRAVELLERS; ORGANISATION OF SIGHTSEEING TOURS; ORGANIZATION OF EXCURSIONS, SIGHTSEEING TOURS, HOLIDAYS, TOURS AND TRAVEL; ORGANIZATION OF TRAVEL AND BOAT TRIPS; ORGANIZATION, BOOKING AND ARRANGEMENT OF EXCURSIONS, DAY TRIPS AND SIGHTSEEING TOURS; PASSENGER SHIP TRANSPORT; PLEASURE BOAT CRUISES; TRANSPORT OF TRAVELLERS (U.S. CLS. 100 AND 105).

CLASS 41—EDUCATION AND ENTERTAINMENT

FOR ARRANGING AND CONDUCTING CANOPY TOURS AND ZIP LINE EVENTS FOR ENTERTAINMENT PURPOSES; GUIDED TOURS OF HISTORICAL, NATURAL, AND CULTURAL SITES (U.S. CLS. 100, 101 AND 107).

ROBIN CHOSID, EXAMINING ATTORNEY

SN 85-276,673. THE TRUSTEES OF LPRP LEGACY TRUST, OAKLAND, CA. FILED 3-25-2011.

CAB'S CAB

THE MARK CONSISTS OF STANDARD CHARACTERS WITHOUT CLAIM TO ANY PARTICULAR FONT, STYLE, SIZE, OR COLOR.

NO CLAIM IS MADE TO THE EXCLUSIVE RIGHT TO USE "CAB", APART FROM THE MARK AS SHOWN.

CLASS 31—NATURAL AGRICULTURAL PRODUCTS

FOR FRESH GRAPES FOR WINEMAKING; FRESH WINE GRAPES (U.S. CLS. 1 AND 46).

CLASS 33—WINES AND SPIRITS

FOR WINES (U.S. CLS. 47 AND 49).
MATTHEW MCDOWELL, EXAMINING ATTORNEY

SN 85-276,811. WELLS, DUGALD, DBA CUBA CRUISE, WATERDOWN, ONTARIO, CANADA, FILED 3-25-2011.

Find Your Cuba

THE MARK CONSISTS OF STANDARD CHARACTERS WITHOUT CLAIM TO ANY PARTICULAR FONT, STYLE, SIZE, OR COLOR.

NO CLAIM IS MADE TO THE EXCLUSIVE RIGHT TO USE "CUBA", APART FROM THE MARK AS SHOWN.

CLASS 39—TRANSPORTATION AND STORAGE

FOR ARRANGING OF CRUISES; BOAT CRUISES; CONDUCTING SIGHTSEEING TOURS BY BOAT; CONDUCTING SIGHTSEEING TOURS FOR OTHERS; COORDINATING TRAVEL ARRANGEMENTS FOR INDIVIDUALS AND FOR GROUPS; CRUISE SHIP SERVICES; ESCORTING TRAVELLERS; ORGANISATION OF SIGHTSEEING TOURS; ORGANISATION OF TRAVEL; ORGANIZATION OF EXCURSIONS, SIGHTSEEING TOURS, HOLIDAYS, TOURS AND TRAVEL; ORGANIZATION OF TRAVEL AND BOAT TRIPS; PASSENGER SHIP TRANSPORT; PLEASURE BOAT CRUISES; RIVER TRANSPORT BY SHIP; TOUR CONDUCTING; TOUR OPERATING; TOUR OPERATING AND ORGANISING; TRANSPORT OF TRAVELLERS (U.S. CLS. 100 AND 105).

CLASS 41—EDUCATION AND ENTERTAINMENT

FOR GUIDED TOURS OF HISTORICAL, NATURAL, AND CULTURAL SITES (U.S. CLS. 100, 101 AND 107).
ROBIN CHOSID, EXAMINING ATTORNEY

SN 85-276,833. LEGAL SEA FOODS, LLC, BOSTON, MA. FILED 3-25-2011.



If it isn't fresh, it isn't Legal!

OWNER OF U.S. REG. NOS. 2,298,231 AND 2,713,727.
NO CLAIM IS MADE TO THE EXCLUSIVE RIGHT TO USE "SEA FOODS", "MARKET" AND "ESTABLISHED 1950", APART FROM THE MARK AS SHOWN.

THE MARK CONSISTS OF AN OVAL SURROUNDING A FISH DESIGN WITH WORDS, "ESTABLISHED 1950", BENEATH THE FISH. A CONTRASTING OVAL WITH WORDS, "LEGAL SEA FOODS", ON THE TOP AND THE WORD, " MARKET", ON THE BOTTOM. UNDERNEATH THE OVAL ARE THE WORDS, "IF IT ISN'T FRESH, IT ISN'T LEGAL!"

CLASS 29—MEATS AND PROCESSED FOODS

FOR FRESH AND FROZEN SEAFOOD, PREPARED TO SERVE SEAFOOD MEALS, SMOKED SEAFOOD, BISQUES, CHOWDERS, CRAB CAKES, QUICHE, HOR D'OEUVRES CONSISTING PRIMARILY OF SEAFOOD, FRUIT AND VEGETABLE SALADS, AND FLAVORED BUTTER (U.S. CL. 46).

CLASS 30—STAPLE FOODS

FOR PASTA SALADS, SAUCES, MARINADES, SANDWICHES, SUSHI AND MAKI ROLLS, BAKERY GOODS, BAGELS, MUFFINS, SCONES, DONUTS, BROWNIES, COOKIES, PIES, COFFEE AND TEA (U.S. CL. 46).

CLASS 32—LIGHT BEVERAGES

FOR FRUIT JUICES (U.S. CLS. 45, 46 AND 48).
HELENE LIWINSKI, EXAMINING ATTORNEY

SN 85-276,969. INCYTE CORPORATION, WILMINGTON, DE. FILED 3-25-2011.



THE MARK CONSISTS OF TWO INTERSECTING SEMI-CIRCLES WITH THE WORD "INCYTE" CONTAINED WITHIN.

CLASS 5—PHARMACEUTICALS

FOR PHARMACEUTICAL PREPARATIONS FOR THE TREATMENT OF VIRAL, HEMATOLOGICAL, ONCOLOGICAL, AUTO-IMMUNE, INFLAMMATORY, METABOLIC, AND DERMATOLOGICAL DISORDERS (U.S. CLS. 6, 18, 44, 46, 51 AND 52).

FIRST USE 7-15-2004; IN COMMERCE 7-15-2004.

CLASS 16—PAPER GOODS AND PRINTED MATTER

FOR PRINTED MEDICAL PUBLICATIONS NAMELY REPORTS, MANUALS, BROCHURES, NEWSLETTERS, LEAFLETS (U.S. CLS. 2, 5, 22, 23, 29, 37, 38 AND 50).

FIRST USE 4-30-2004; IN COMMERCE 4-30-2004.

CLASS 42—SCIENTIFIC AND COMPUTER SERVICES

FOR SCIENTIFIC AND MEDICAL RESEARCH RELATING TO VIRAL, HEMATOLOGICAL, ONCOLOGICAL, AUTO-IMMUNE, INFLAMMATORY, METABOLIC, AND DERMATOLOGICAL DISORDERS (U.S. CLS. 100 AND 101).

FIRST USE 4-30-2004; IN COMMERCE 4-30-2004.

CLASS 44—MEDICAL, BEAUTY AND AGRICULTURAL SERVICES

FOR PROVIDING A WEB SITE FEATURING INFORMATION RELATING TO VIRAL, HEMATOLOGICAL, ONTOLOGICAL, AUTO-IMMUNE, INFLAMMATORY, METABOLIC AND DERMATOLOGICAL DISORDERS (U.S. CLS. 100 AND 101).

FIRST USE 7-16-2004; IN COMMERCE 7-16-2004.

KARANENDRA S. CHHINA, EXAMINING ATTORNEY

SN 85-277,007. JKS BUSINESS SOLUTIONS, INC., CORAL SPRINGS, FL. FILED 3-25-2011.

JKS Business Solutions

THE MARK CONSISTS OF STANDARD CHARACTERS WITHOUT CLAIM TO ANY PARTICULAR FONT, STYLE, SIZE, OR COLOR.

NO CLAIM IS MADE TO THE EXCLUSIVE RIGHT TO USE "BUSINESS SOLUTIONS", APART FROM THE MARK AS SHOWN.

CLASS 35—ADVERTISING AND BUSINESS

FOR ACCOUNTANCY SERVICES; ACCOUNTING CONSULTATION; ACCOUNTING FOR THIRD PARTIES; ACCOUNTING SERVICES; ACCOUNTS RECEIVABLE SERVICES; ADMINISTRATION OF BUSINESS PAYROLL FOR OTHERS; ADMINISTRATION, BILLING AND RECONCILIATION OF ACCOUNTS ON BEHALF OF OTHERS; ADMINISTRATIVE ACCOUNTING; BUSINESS INFORMATION AND ACCOUNTING ADVISORY SERVICES; BUSINESS INVOICING SERVICES; BUSINESS SERVICES, NAMELY, TIMEKEEPING SERVICES FOR OTHERS; CONSULTING AND INFORMATION CONCERNING ACCOUNTING; COST ACCOUNTING; COST ANALYSES; COST ASSESSMENT SERVICES; INVOICING; INVOICING SERVICES; OUTSOURCING IN THE FIELD OF FINANCIAL MANAGEMENT, NAMELY BOOKKEEPING, FINANCIAL REPORTING, COST CONTROL, PAYROLL SERVICES, BILL PAYMENT, COLLECTIONS, AND RECONCILIATION; PAYROLL ADMINISTRATION AND MANAGEMENT SERVICES; PAYROLL PREPARATION; PAYROLL PROCESSING SERVICES; PREPARATION OF BUSINESS REPORTS; PREPARATION OF REPORTS RELATING TO FINANCE AND INVESTMENTS; PREPARING BUSINESS REPORTS; PREPARING FINANCIAL REPORTS FOR OTHERS; WAGE PAYROLL PREPARATION (U.S. CLS. 100, 101 AND 102).

FIRST USE 6-21-2001; IN COMMERCE 6-21-2001.

CLASS 41—EDUCATION AND ENTERTAINMENT

FOR BUSINESS TRAINING; BUSINESS TRAINING CONSULTANCY SERVICES; COMPUTER EDUCATION TRAINING; COMPUTER EDUCATION TRAINING SERVICES; EDUCATIONAL SERVICES, NAMELY, CONDUCTING CLASSES, SEMINARS, WORKSHOPS AND CONFERENCES IN THE FIELD OF ACCOUNTING, BOOKKEEPING, FINANCIAL MANAGEMENT AND FINANCIAL SOFTWARE AND DISTRIBUTION OF EDUCATIONAL MATERIALS IN CONNECTION THEREWITH (U.S. CLS. 100, 101 AND 107).

FIRST USE 6-21-2001; IN COMMERCE 6-21-2001.
KARANENDRA S. CHHINA, EXAMINING ATTORNEY

SN 85-277,095. AVISTA RENTALS, LLC, NORTH MYRTLE BEACH, SC. FILED 3-25-2011.

AVISTA RESORT

THE MARK CONSISTS OF STANDARD CHARACTERS WITHOUT CLAIM TO ANY PARTICULAR FONT, STYLE, SIZE, OR COLOR.

NO CLAIM IS MADE TO THE EXCLUSIVE RIGHT TO USE "RESORT", APART FROM THE MARK AS SHOWN.

CLASS 36—INSURANCE AND FINANCIAL

FOR REAL ESTATE SERVICES, NAMELY, BROKERAGE, LISTING AND RENTAL OF CONDOMINIUMS (U.S. CLS. 100, 101 AND 102).

FIRST USE 2-28-2005; IN COMMERCE 2-28-2005.

CLASS 43—HOTEL AND RESTAURANT SERVICES

FOR HOTEL AND RESORT HOTEL SERVICES (U.S. CLS. 100 AND 101).

FIRST USE 2-28-2005; IN COMMERCE 2-28-2005.
NICHOLAS ALTREE, EXAMINING ATTORNEY

SN 85-277,103. ARCADIS N.V., AMSTERDAM, NETHERLANDS, FILED 3-25-2011.



OWNER OF U.S. REG. NOS. 2,236,634, 3,662,375 AND OTHERS.

NO CLAIM IS MADE TO THE EXCLUSIVE RIGHT TO USE "THE WATER DIVISION OF", APART FROM THE MARK AS SHOWN.

THE NAME "MALCOLM PIRNIE" DOES NOT IDENTIFY A LIVING INDIVIDUAL.

THE MARK CONSISTS OF A STYLIZED REPRESENTATION OF THE PHRASE "MALCOLM PIRNIE" FRAMED IN A RECTANGULAR BOX TO THE LEFT OF A STYLIZED REPRESENTATION OF A SALAMANDER FOLLOWED BY THE WORD "ARCADIS"; ALL OF WHICH SITS ATOP THE PHRASE "THE WATER DIVISION OF ARCADIS". THE "MALCOLM PIRNIE" PORTION OF THE MARK IS SEPARATED FROM THE SALAMANDER DESIGN BY A THIN VERTICAL LINE.

CLASS 35—ADVERTISING AND BUSINESS

FOR BUSINESS MANAGEMENT CONSULTATION; ECONOMIC FORECASTING AND ANALYSIS FOR BUSINESS (U.S. CLS. 100, 101 AND 102).

FIRST USE 1-1-2011; IN COMMERCE 3-15-2011.

CLASS 36—INSURANCE AND FINANCIAL

FOR FINANCIAL MANAGEMENT SERVICES AND ONGOING FINANCIAL ASSISTANCE SERVICES IN THE NATURE OF ECONOMIC ANALYSIS AND ESTABLISHMENT OF RATES AND CHARGES FOR INDUSTRIES, MUNICIPALITIES, STATE GOVERNMENTS, AND PUBLICLY-OWNED TREATMENT WORKS (U.S. CLS. 100, 101 AND 102).

FIRST USE 1-1-2011; IN COMMERCE 3-15-2011.

CLASS 37—CONSTRUCTION AND REPAIR

FOR CONSULTING SERVICES FOR THE CONSTRUCTION OF WATER TREATMENT AND PURIFICATION PLANTS, SOLID WASTE TREATMENT PLANTS AND OTHER MUNICIPAL INFRASTRUCTURE FACILITIES (U.S. CLS. 100, 103 AND 106).

FIRST USE 1-1-2011; IN COMMERCE 3-15-2011.

CLASS 42—SCIENTIFIC AND COMPUTER SERVICES

FOR ENGINEERING SERVICES FOR THE CONSTRUCTION OF WATER TREATMENT AND PURIFICATION PLANTS, SOLID WASTE TREATMENT PLANTS AND OTHER MUNICIPAL INFRASTRUCTURE FACILITIES; AIR POLLUTION CONTROL SERVICES, NAMELY, CUSTOM DESIGN OF AIR POLLUTION CONTROL SYSTEMS AND EQUIPMENT FOR OTHERS (U.S. CLS. 100 AND 101).

FIRST USE 1-1-2011; IN COMMERCE 3-15-2011.
JAMES LOVELACE, EXAMINING ATTORNEY

SN 85-277,296. TOPCU CORPORATION, DULUTH, GA.
FILED 3-25-2011.

TOPCU TILE & STONE

THE MARK CONSISTS OF STANDARD CHARACTERS WITHOUT CLAIM TO ANY PARTICULAR FONT, STYLE, SIZE, OR COLOR.

NO CLAIM IS MADE TO THE EXCLUSIVE RIGHT TO USE "TILE & STONE", APART FROM THE MARK AS SHOWN.

CLASS 19—NON-METALLIC BUILDING MATERIALS

FOR NATURAL STONE, PAVERS, CERAMIC TILES, STONE TILES, GLASS TILES, MOSAIC TILES MADE OF STONE (U.S. CLS. 1, 12, 33 AND 50).

FIRST USE 6-13-2003; IN COMMERCE 6-13-2003.

CLASS 21—HOUSEWARES AND GLASS

FOR GLASS, CERAMIC AND PORCELAIN MOSAIC TILES (U.S. CLS. 2, 13, 23, 29, 30, 33, 40 AND 50).

FIRST USE 6-13-2003; IN COMMERCE 6-13-2003.

CLASS 35—ADVERTISING AND BUSINESS

FOR WHOLESALE AND RETAIL STORE SERVICES AND ON-LINE RETAIL AND WHOLESALE STORE SERVICES FEATURING NATURAL STONE, PAVERS, CERAMIC TILES, STONE TILES, GLASS TILES, MOSAIC TILES (U.S. CLS. 100, 101 AND 102).

FIRST USE 6-13-2003; IN COMMERCE 6-13-2003.

RUDY R. SINGLETON, EXAMINING ATTORNEY

SN 85-277,356. AMERICAN UNIVERSITY, WASHINGTON, DC. FILED 3-25-2011.



NO CLAIM IS MADE TO THE EXCLUSIVE RIGHT TO USE "88.5", APART FROM THE MARK AS SHOWN.

THE MARK CONSISTS OF A STYLIZED RENDERING OF THE LETTERS "W", "A", "M", AND "U". THE LETTERS ARE FORMED BY HALF OVAL SHAPES THAT INTERSECT. THE LETTERS "W", "A", "M", "U" AND NUMBER "88.5" APPEAR IN THE CENTER OF THE SHAPES.

SEC. 2(F) AS TO "WAMU".

CLASS 38—COMMUNICATION

FOR RADIO BROADCASTING SERVICES AND ON-LINE INTERNET RADIO BROADCASTING SERVICES (U.S. CLS. 100, 101 AND 104).

FIRST USE 2-16-2011; IN COMMERCE 2-16-2011.

CLASS 41—EDUCATION AND ENTERTAINMENT

FOR ENTERTAINMENT IN THE NATURE OF ONGOING RADIO PROGRAMS IN THE FIELD OF MUSIC, TALK RADIO, CULTURAL NEWS, PUBLIC AFFAIRS NEWS AND TECHNOLOGY NEWS (U.S. CLS. 100, 101 AND 107).

FIRST USE 2-16-2011; IN COMMERCE 2-16-2011.

THEODORE MCBRIDE, EXAMINING ATTORNEY

SN 85-277,383. THE WILLIAMS COMPANIES, INC., TULSA, OK. FILED 3-25-2011.

WPX ENERGY

THE MARK CONSISTS OF STANDARD CHARACTERS WITHOUT CLAIM TO ANY PARTICULAR FONT, STYLE, SIZE, OR COLOR.

NO CLAIM IS MADE TO THE EXCLUSIVE RIGHT TO USE "ENERGY", APART FROM THE MARK AS SHOWN.

CLASS 40—MATERIAL TREATMENT

FOR GAS PRODUCTION SERVICES; OIL PRODUCTION SERVICES (U.S. CLS. 100, 103 AND 106).

CLASS 42—SCIENTIFIC AND COMPUTER SERVICES

FOR EXPLORATION AND SEARCHING OF OIL AND GAS (U.S. CLS. 100 AND 101).

THEODORE MCBRIDE, EXAMINING ATTORNEY

SN 85-277,387. CYNERGY SYSTEMS, INC., WASHINGTON, DC. FILED 3-25-2011.

MOTIVATIONAL DESIGN

THE MARK CONSISTS OF STANDARD CHARACTERS WITHOUT CLAIM TO ANY PARTICULAR FONT, STYLE, SIZE, OR COLOR.

NO CLAIM IS MADE TO THE EXCLUSIVE RIGHT TO USE "DESIGN" IN CLASSES 41 AND 42, APART FROM THE MARK AS SHOWN.

CLASS 35—ADVERTISING AND BUSINESS

FOR ASSISTANCE IN MANAGEMENT OF BUSINESS ACTIVITIES; ASSISTANCE WITH BUSINESS MANAGEMENT AND PLANNING; BUSINESS MANAGEMENT CONSULTANCY SERVICES; BUSINESS MANAGEMENT CONSULTANCY, ALSO VIA THE INTERNET; CONSULTING SERVICES IN BUSINESS ORGANIZATION AND MANAGEMENT; MANAGEMENT AND BUSINESS CONSULTING SERVICES IN THE FIELD OF INTERACTIVE INTERNET SOFTWARE AND GRAPHICS (U.S. CLS. 100, 101 AND 102).

FIRST USE 1-15-2010; IN COMMERCE 7-11-2010.

CLASS 38—COMMUNICATION

FOR COMPUTER AIDED TRANSMISSION OF INFORMATION AND IMAGES; COMPUTER TRANSMISSION OF INFORMATION ACCESSED VIA A CODE OR A TERMINAL; COMPUTER-AIDED TRANSMISSION OF MESSAGES; COMPUTER-AIDED TRANSMISSION OF MESSAGES AND IMAGES; ELECTRONIC MESSAGE TRANSMISSION; ELECTRONIC TRANSMISSION OF DATA AND DOCUMENTS VIA COMPUTER TERMINALS; ELECTRONIC TRANSMISSION OF DATA AND DOCUMENTS VIA COMPUTER TERMINALS AND ELECTRONIC DEVICES; ELECTRONIC TRANSMISSION OF MESSAGES AND DATA; TRANSMISSION OF INFORMATION THROUGH VIDEO COMMUNICATION SYSTEMS; TRANSMISSION OF SOUND, VIDEO AND INFORMATION; VIDEO BROADCASTING; VIDEO NARROWCASTING SERVICES; VIDEO TELECONFERENCING; WIRELESS COMMUNICATIONS SERVICES, NAMELY, TRANSMISSION OF GRAPHICS TO MOBILE TELEPHONES; WIRELESS ELECTRONIC TRANSMISSION OF VOICE SIGNALS, DATA, FACSIMILES, IMAGES AND INFORMATIONS (U.S. CLS. 100, 101 AND 104).

FIRST USE 1-15-2010; IN COMMERCE 7-11-2010.

CLASS 41—EDUCATION AND ENTERTAINMENT

FOR AUDIO AND VIDEO RECORDING SERVICES; COMPUTER EDUCATION TRAINING; COMPUTER EDUCATION TRAINING SERVICES; DIGITAL VIDEO, AUDIO, AND MULTIMEDIA PUBLISHING SERVICES; MULTIMEDIA ENTERTAINMENT SERVICES IN THE NATURE OF RECORDING, PRODUCTION AND POST-PRODUCTION SERVICES IN THE FIELDS OF MUSIC, VIDEO, AND FILMS; MULTIMEDIA ENTERTAINMENT SOFTWARE PRODUCTION SERVICES; TRAINING IN THE FIELD OF DESIGN, ADVERTISING AND COMMUNICATION TECHNOLOGIES; TRAINING IN THE USE OF INTERNET INTERACTIVE SOFTWARE AND GRAPHICS (U.S. CLS. 100, 101 AND 107).

FIRST USE 1-15-2010; IN COMMERCE 7-11-2010.

CLASS 42—SCIENTIFIC AND COMPUTER SERVICES

FOR COMPUTER CONSULTATION; COMPUTER HARDWARE AND SOFTWARE CONSULTING SERVICES; COMPUTER NETWORK DESIGN AND COMPUTER SOFTWARE DESIGN FOR THE INTERACTIVE INTERNET MARKETING INDUSTRY; COMPUTER PROGRAMMING; COMPUTER PROGRAMMING AND MAINTENANCE OF COMPUTER PROGRAMS; COMPUTER PROGRAMMING AND SOFTWARE DESIGN; COMPUTER PROGRAMMING FOR OTHERS; COMPUTER PROGRAMMING IN THE MEDICAL FIELD; COMPUTER PROJECT MANAGEMENT SERVICES; COMPUTER SOFTWARE CONSULTANCY; COMPUTER SOFTWARE CONSULTATION; COMPUTER SOFTWARE CONSULTING; COMPUTER SOFTWARE DESIGN; COMPUTER SOFTWARE DESIGN AND UPDATING; COMPUTER SOFTWARE DESIGN FOR OTHERS; COMPUTER SOFTWARE DESIGN, COMPUTER PROGRAMMING, OR MAINTENANCE OF COMPUTER SOFTWARE; COMPUTER SOFTWARE DEVELOPMENT; COMPUTER SOFTWARE DEVELOPMENT AND COMPUTER PROGRAMMING DEVELOPMENT FOR OTHERS; COMPUTER SOFTWARE DEVELOPMENT IN THE FIELD OF INTERNET INTERACTIVE SOFTWARE AND GRAPHICS; COMPUTER SOFTWARE DEVELOPMENT, COMPUTER PROGRAMMING AND MAINTENANCE OF COMPUTER SOFTWARE FOR INTERACTIVE INTERNET MARKETING INDUSTRY; CONSULTING IN THE FIELD OF SOFTWARE AND PRODUCT DEVELOPMENT IN THE FIELD OF INTERNET INTERACTIVE SOFTWARE AND GRAPHICS; CONSULTING IN THE FIELD OF SOFTWARE DEVELOPMENT AND PRODUCT DEVELOPMENT IN THE FIELD OF INTERNET INTERACTIVE SOFTWARE AND GRAPHICS; CONSULTING IN THE FIELD OF SOFTWARE DEVELOPMENT IN THE FIELD OF INTERNET INTERACTIVE SOFTWARE AND GRAPHICS; CONSULTING SERVICES IN THE FIELD OF THE DESIGN OF INTERNET INTERACTIVE SOFTWARE AND GRAPHICS; DESIGN, DEPLOYMENT AND MANAGEMENT OF WIRELESS NETWORKS FOR OTHERS; DESIGN, DEVELOPMENT AND CONSULT-

ING SERVICES IN THE FIELD OF SOFTWARE FOR CONTENT MANAGEMENT; DESIGN, DEVELOPMENT AND IMPLEMENTATION OF SOFTWARE; DESIGN, DEVELOPMENT, AND CONSULTING SERVICES IN THE FIELD OF HOME AND WORKPLACE AUTOMATION HARDWARE AND SOFTWARE; DESIGN, DEVELOPMENT, INSTALLATION AND MAINTENANCE OF COMPUTER SOFTWARE; DESIGN, MAINTENANCE, DEVELOPMENT AND UPDATING OF COMPUTER SOFTWARE; DESIGN, UPDATING AND RENTAL OF COMPUTER SOFTWARE; DEVELOPING AND UPDATING COMPUTER SOFTWARE; DEVELOPMENT, MAINTENANCE AND UPDATING OF A TELECOMMUNICATION NETWORK SEARCH ENGINE; DEVELOPMENT, UPDATING AND MAINTENANCE OF SOFTWARE AND DATA BASES; TECHNICAL CONSULTING AND ASSISTANCE WITH COMPUTER-BASED INFORMATION SYSTEMS AND COMPONENTS; TECHNICAL SUPPORT SERVICES, NAMELY, TROUBLESHOOTING OF COMPUTER SOFTWARE PROBLEMS (U.S. CLS. 100 AND 101).

FIRST USE 1-10-2010; IN COMMERCE 7-11-2010.

KAREN K. BUSH, EXAMINING ATTORNEY

SN 85-277,440. MARK PETRIE-DIEVE, FAIRFAX, CA. AND STACY WEINBERG DIEVE, FAIRFAX, CA. FILED 3-25-2011.

Rooted Health

THE MARK CONSISTS OF STANDARD CHARACTERS WITHOUT CLAIM TO ANY PARTICULAR FONT, STYLE, SIZE, OR COLOR.

NO CLAIM IS MADE TO THE EXCLUSIVE RIGHT TO USE "HEALTH", APART FROM THE MARK AS SHOWN.

CLASS 41—EDUCATION AND ENTERTAINMENT

FOR HERBALISM AND ENVIRONMENTAL HEALTH EDUCATIONAL SERVICES, NAMELY, PROVIDING LIVE AND ON-LINE CLASSES, SEMINARS, WORKSHOPS, CONFERENCES, LECTURES, PANEL DISCUSSIONS AND COURSES OF INSTRUCTION IN THE FIELD OF HOLISTIC AND ENVIRONMENTAL HEALTH, HERBALISM AND WELLNESS (U.S. CLS. 100, 101 AND 107).

FIRST USE 7-13-2010; IN COMMERCE 9-1-2010.

CLASS 44—MEDICAL, BEAUTY AND AGRICULTURAL SERVICES

FOR PROVIDING INFORMATION AND CONSULTATION SERVICES IN THE FIELD OF HOLISTIC HEALTH SERVICES, NAMELY, HOLISTIC AND ENVIRONMENTAL HEALTH, HERBALISM AND WELLNESS (U.S. CLS. 100 AND 101).

FIRST USE 7-13-2010; IN COMMERCE 9-1-2010.

MARIA-VICTORIA SUAREZ, EXAMINING ATTORNEY

SN 85-277,654. GRACE TO YOU, VALENCIA, CA. FILED 3-25-2011.

**DESATANDO LA VERDAD DE
DIOS UN VERSICULO A LA VEZ**

THE MARK CONSISTS OF STANDARD CHARACTERS WITHOUT CLAIM TO ANY PARTICULAR FONT, STYLE, SIZE, OR COLOR.

OWNER OF U.S. REG. NOS. 2,216,086 AND 2,261,534.

THE ENGLISH TRANSLATION OF "DESATANDO LA VERDAD DE DIOS UN VERSICULO A LA VEZ" IN THE MARK IS "UNLEASHING GOD'S TRUTH ONE VERSE AT A TIME".

CLASS 16—PAPER GOODS AND PRINTED MATTER

FOR PRINTED MATTER, NAMELY, RELIGIOUS NEWSLETTERS, BROCHURES, CATALOGS AND PAMPHLETS; AND PRINTED INSTRUCTIONAL AND TEACHING MATERIALS, NAMELY BOOKS AND BOOKLETS IN THE FIELD OF RELIGION (U.S. CLS. 2, 5, 22, 23, 29, 37, 38 AND 50).

CLASS 41—EDUCATION AND ENTERTAINMENT

FOR RADIO PROGRAMS WITH RELIGIOUS SUBJECT MATTER (U.S. CLS. 100, 101 AND 107).

CLASS 45—PERSONAL AND LEGAL SERVICES

FOR PROVIDING INFORMATION OF A RELIGIOUS NATURE VIA A GLOBAL COMPUTER NETWORK (U.S. CLS. 100 AND 101).

ELIZABETH HUGHITT, EXAMINING ATTORNEY

SN 85-277,761. GLOVEABLES, INC., DBA LINDY-LOUS, LOS ANGELES, CA. FILED 3-26-2011.

Gloveables

THE MARK CONSISTS OF STANDARD CHARACTERS WITHOUT CLAIM TO ANY PARTICULAR FONT, STYLE, SIZE, OR COLOR.

OWNER OF U.S. REG. NOS. 2,702,157 AND 3,575,373.

CLASS 3—COSMETICS AND CLEANING PREPARATIONS

FOR 3-IN-1 ORGANIC SOAP BARS FOR USE AS SOAP, SHAMPOO AND CONDITIONER; ALL PURPOSE CLEANING PREPARATION WITH DEODORIZING PROPERTIES; ALL PURPOSE CLEANING PREPARATIONS; ALMOND SOAPS; AMMONIA FOR CLEANING PURPOSES; ANTI-BACTERIAL SOAP; ANTIBACTERIAL SOAP; BAR SOAP; BATH SOAPS; BATH SOAPS IN LIQUID, SOLID OR GEL FORM; CAKES OF TOILET SOAP; CLEANING PREPARATIONS FOR CLEANING SURFACES; CLEANING SWABS FOR HOUSEHOLD PURPOSES; CLEANING, POLISHING AND SCOURING PREPARATIONS; CLEANING, SCOURING AND POLISHING PREPARATIONS AND SUBSTANCES; CLEANING, WASHING AND POLISHING PREPARATIONS; CLOTHS IMPREGNATED WITH A DETERGENT FOR CLEANING; COMPRESSED AIR IN CANS FOR CLEANING AND DUSTING; COSMETIC SOAPS; CREAM SOAPS; DEODORANT SOAP; DETERGENT SOAP; DISINFECTANT SOAPS; DISPOSABLE WIPES IMPREGNATED WITH CLEANING CHEMICALS OR COMPOUNDS FOR INDUSTRIAL AND COMMERCIAL USE; FABRIC SOFTENERS FOR LAUNDRY USE (U.S. CLS. 1, 4, 6, 50, 51 AND 52).

CLASS 21—HOUSEWARES AND GLASS

FOR CLEANING AND POLISHING CLOTHS; CLEANING MITTS OF FABRIC; CLEANING RAGS; CLEANING SPONGES; CLEANING SWABS FOR COMMERCIAL USES; DISHWASHING BRUSHES; DISPENSERS FOR CLEANING AND DISINFECTING SOLUTIONS; FEATHER BROOMS; FLOOR BRUSHES; HARD BROOMS; MOPS; SCRUB SPONGES; TOILET BRUSH HOLDERS; TOILET BRUSHES (U.S. CLS. 2, 13, 23, 29, 30, 33, 40 AND 50).

IRA J. GOODSaid, EXAMINING ATTORNEY

SN 85-277,924. MERIDIUM, INC., ROANOKE, VA. FILED 3-26-2011.

INDUSTRY ANSWERS

THE MARK CONSISTS OF STANDARD CHARACTERS WITHOUT CLAIM TO ANY PARTICULAR FONT, STYLE, SIZE, OR COLOR.

NO CLAIM IS MADE TO THE EXCLUSIVE RIGHT TO USE "INDUSTRY", APART FROM THE MARK AS SHOWN.

CLASS 9—ELECTRICAL AND SCIENTIFIC APPARATUS

FOR COMPUTER PROGRAMS FOR STORING, MANAGING, TRACKING, EXTRACTING, ANALYZING, AND REPORTING DATA AND METRICS IN THE FIELD OF ASSET RELIABILITY AND MAINTENANCE MANAGEMENT (U.S. CLS. 21, 23, 26, 36 AND 38).

CLASS 42—SCIENTIFIC AND COMPUTER SERVICES

FOR PROVIDING TEMPORARY USE OF ON-LINE NON-DOWNLOADABLE SOFTWARE FOR STORING, MANAGING, TRACKING, EXTRACTING, ANALYZING, AND REPORTING DATA AND METRICS IN THE FIELD OF ASSET RELIABILITY AND MAINTENANCE MANAGEMENT (U.S. CLS. 100 AND 101).

Laurie Kaufman, EXAMINING ATTORNEY

SN 85-278,170. LAURENT, LAVIGNE, LOS ANGELES, CA.
FILED 3-28-2011.

elephantopia

THE MARK CONSISTS OF STANDARD CHARACTERS WITHOUT CLAIM TO ANY PARTICULAR FONT, STYLE, SIZE, OR COLOR.

CLASS 9—ELECTRICAL AND SCIENTIFIC APPARATUS

FOR VIDEO GAME SOFTWARE FOR MOBILE PHONE, TABLET COMPUTER, INTERNET BROWSER, PERSONAL COMPUTER AND CONSOLE (U.S. CLS. 21, 23, 26, 36 AND 38).

FIRST USE 10-14-2010; IN COMMERCE 1-1-2011.

CLASS 28—TOYS AND SPORTING GOODS

FOR PLUSH TOYS, BOARD GAMES, PLASTIC TOY CHARACTERS, PLASTIC TOY BUILDINGS, PLASTIC TOY CARS, AND PLASTIC TOY MACHINES (U.S. CLS. 22, 23, 38 AND 50).

DORITT L. CARROLL, EXAMINING ATTORNEY

SN 85-278,418. ONE CELEBRATIONS LLC, OVERLAND PARK, KS. FILED 3-28-2011.

CELEBRATIONS THAT GIVE BACK

THE MARK CONSISTS OF STANDARD CHARACTERS WITHOUT CLAIM TO ANY PARTICULAR FONT, STYLE, SIZE, OR COLOR.

CLASS 9—ELECTRICAL AND SCIENTIFIC APPARATUS

FOR DIGITAL MATERIALS AND ELECTRONIC PUBLICATIONS, NAMELY, EBOOKS CDS, DVDS, DOWNLOADABLE AUDIO FILES, PODCASTS, NEWSLETTERS, ONLINE DISCUSSION BOARDS, WEBCASTS, AUDIO FILES AND MP3 FILES, ALL THE FOREGOING IN DOWNLOADABLE FORMAT, IN THE FIELDS OF HUMANITARIAN EFFORTS, SOCIAL RESPONSIBILITY, SOCIAL JUSTICE, ENVIRONMENTAL CONSCIOUSNESS, SUSTAINABILITY AND CHARITABLE GIVING (U.S. CLS. 21, 23, 26, 36 AND 38).

CLASS 16—PAPER GOODS AND PRINTED MATTER

FOR A SERIES OF BOOKS, WRITTEN ARTICLES, HANDOUTS AND WORKSHEETS IN THE FIELDS OF HUMANITARIAN EFFORTS, SOCIAL RESPONSIBILITY, SOCIAL JUSTICE, ENVIRONMENTAL CONSCIOUSNESS, SUSTAINABILITY AND CHARITABLE GIVING (U.S. CLS. 2, 5, 22, 23, 29, 37, 38 AND 50).

CLASS 35—ADVERTISING AND BUSINESS

FOR PROMOTING THE GOODS AND SERVICES OF OTHERS BY PROVIDING A WEB SITE THAT FEATURES PRODUCT AND SERVICES REVIEWS, PRODUCT RECOMMENDATIONS, PRODUCT ENDORSEMENTS, PRODUCT RATINGS OF THE CONSUMER GOODS OF OTHERS, PURCHASE SOURCE INFORMATION, NAMELY, PRODUCT LINKS TO THE WEBSITES OF OTHERS, AND THE PROVISION OF ADVICE TO CONSUMERS REGARDING THE SELECTION OF PRODUCTS AND ITEMS TO BE PURCHASED, ALL IN THE FIELDS OF HUMANITARIAN EFFORTS, SOCIAL RESPONSIBILITY, SOCIAL JUSTICE, ENVIRONMENTAL CONSCIOUSNESS, SUSTAINABILITY AND CHARITABLE GIVING (U.S. CLS. 100, 101 AND 102).

CLASS 38—COMMUNICATION

FOR PROVIDING ON-LINE CHAT ROOMS AND ELECTRONIC BULLETIN BOARDS FOR TRANSMISSION OF MESSAGES AMONG USERS IN THE FIELDS OF HUMANITARIAN EFFORTS, SOCIAL RESPONSIBILITY, SOCIAL JUSTICE, ENVIRONMENTAL CONSCIOUSNESS, SUSTAINABILITY AND CHARITABLE GIVING (U.S. CLS. 100, 101 AND 104).

CLASS 41—EDUCATION AND ENTERTAINMENT

FOR PROVIDING A WEBSITE FEATURING BLOGS, ONLINE JOURNALS AND NON-DOWNLOADABLE PUBLICATIONS IN THE NATURE OF ARTICLES AND PRODUCT REVIEWS IN THE FIELDS OF HUMANITARIAN EFFORTS, SOCIAL RESPONSIBILITY, SOCIAL JUSTICE, ENVIRONMENTAL CONSCIOUSNESS, SUSTAINABILITY AND CHARITABLE GIVING; EDUCATION SERVICES, NAMELY, PROVIDING LIVE AND ON-LINE CLASSES, SEMINARS, WORKSHOPS IN THE FIELDS OF HUMANITARIAN EFFORTS, SOCIAL RESPONSIBILITY, SOCIAL JUSTICE, ENVIRONMENTAL CONSCIOUSNESS, SUSTAINABILITY AND CHARITABLE GIVING (U.S. CLS. 100, 101 AND 107).

JANET LEE, EXAMINING ATTORNEY

SN 85-278,428. ONE CELEBRATIONS LLC, OVERLAND PARK, KS. FILED 3-28-2011.

SPACES THAT GIVE BACK

THE MARK CONSISTS OF STANDARD CHARACTERS WITHOUT CLAIM TO ANY PARTICULAR FONT, STYLE, SIZE, OR COLOR.

CLASS 9—ELECTRICAL AND SCIENTIFIC APPARATUS

FOR DIGITAL MATERIALS AND ELECTRONIC PUBLICATIONS, NAMELY, EBOOKS CDS, DVDS, DOWNLOADABLE AUDIO FILES, PODCASTS, NEWSLETTERS, ONLINE DISCUSSION BOARDS, WEBCASTS, AUDIO FILES AND MP3 FILES, ALL THE FOREGOING IN DOWNLOADABLE FORMAT, IN THE FIELDS OF HUMANITARIAN EFFORTS, SOCIAL RESPONSIBILITY, SOCIAL JUSTICE, ENVIRONMENTAL CONSCIOUSNESS, SUSTAINABILITY AND CHARITABLE GIVING (U.S. CLS. 21, 23, 26, 36 AND 38).

CLASS 16—PAPER GOODS AND PRINTED MATTER

FOR A SERIES OF BOOKS, WRITTEN ARTICLES, HANDOUTS AND WORKSHEETS IN THE FIELDS OF HUMANITARIAN EFFORTS, SOCIAL RESPONSIBILITY, SOCIAL JUSTICE, ENVIRONMENTAL CONSCIOUSNESS, SUSTAINABILITY AND CHARITABLE GIVING (U.S. CLS. 2, 5, 22, 23, 29, 37, 38 AND 50).

CLASS 35—ADVERTISING AND BUSINESS

FOR PROMOTING THE GOODS AND SERVICES OF OTHERS BY PROVIDING A WEB SITE THAT FEATURES PRODUCT AND SERVICES REVIEWS, PRODUCT RECOMMENDATIONS, PRODUCT ENDORSEMENTS, PRODUCT RATINGS OF THE CONSUMER GOODS OF OTHERS, PURCHASE SOURCE INFORMATION, NAMELY, PRODUCT LINKS TO THE WEBSITES OF OTHERS, AND THE PROVISION OF ADVICE TO CONSUMERS REGARDING THE SELECTION OF PRODUCTS AND ITEMS TO BE PURCHASED, ALL IN THE FIELDS OF HUMANITARIAN EFFORTS, SOCIAL RESPONSIBILITY, SOCIAL JUSTICE, ENVIRONMENTAL CONSCIOUSNESS, SUSTAINABILITY AND CHARITABLE GIVING (U.S. CLS. 100, 101 AND 102).

CLASS 38—COMMUNICATION

FOR PROVIDING ON-LINE CHAT ROOMS AND ELECTRONIC BULLETIN BOARDS FOR TRANSMISSION OF MESSAGES AMONG USERS IN THE FIELDS OF HUMANITARIAN EFFORTS, SOCIAL RESPONSIBILITY, SOCIAL JUSTICE, ENVIRONMENTAL CONSCIOUSNESS, SUSTAINABILITY AND CHARITABLE GIVING (U.S. CLS. 100, 101 AND 104).

CLASS 41—EDUCATION AND ENTERTAINMENT

FOR PROVIDING A WEBSITE FEATURING BLOGS, ONLINE JOURNALS AND NON-DOWNLOADABLE PUBLICATIONS IN THE NATURE OF ARTICLES AND PRODUCT REVIEWS IN THE FIELDS OF HUMANITARIAN EFFORTS, SOCIAL RESPONSIBILITY, SOCIAL JUSTICE, ENVIRONMENTAL CONSCIOUSNESS, SUSTAINABILITY AND CHARITABLE GIVING; EDUCATION SERVICES, NAMELY, PROVIDING LIVE AND ON-LINE CLASSES, SEMINARS, WORKSHOPS IN THE FIELDS OF HUMANITARIAN EFFORTS, SOCIAL RESPONSIBILITY, SOCIAL JUSTICE, ENVIRONMENTAL CONSCIOUSNESS, SUSTAINABILITY AND CHARITABLE GIVING (U.S. CLS. 100, 101 AND 107).

JANET LEE, EXAMINING ATTORNEY

SN 85-278,447. ONE CELEBRATIONS LLC, OVERLAND PARK, KS. FILED 3-28-2011.

DIARY OF A GOOD GIRL

THE MARK CONSISTS OF STANDARD CHARACTERS WITHOUT CLAIM TO ANY PARTICULAR FONT, STYLE, SIZE, OR COLOR.

CLASS 9—ELECTRICAL AND SCIENTIFIC APPARATUS

FOR DIGITAL MATERIALS AND ELECTRONIC PUBLICATIONS, NAMELY, EBOOKS CDS, DVDS, DOWNLOADABLE AUDIO FILES, PODCASTS, NEWSLETTERS, ONLINE DISCUSSION BOARDS, WEBCASTS, AUDIO FILES AND MP3 FILES, ALL THE FOREGOING IN DOWNLOADABLE FORMAT, IN THE FIELDS OF HUMANITARIAN EFFORTS, SOCIAL RESPONSIBILITY, SOCIAL JUSTICE, ENVIRONMENTAL CONSCIOUSNESS, SUSTAINABILITY AND CHARITABLE GIVING (U.S. CLS. 21, 23, 26, 36 AND 38).

CLASS 16—PAPER GOODS AND PRINTED MATTER

FOR A SERIES OF BOOKS, WRITTEN ARTICLES, HANDOUTS AND WORKSHEETS IN THE FIELDS OF HUMANITARIAN EFFORTS, SOCIAL RESPONSIBILITY, SOCIAL JUSTICE, ENVIRONMENTAL CONSCIOUSNESS, SUSTAINABILITY AND CHARITABLE GIVING (U.S. CLS. 2, 5, 22, 23, 29, 37, 38 AND 50).

CLASS 35—ADVERTISING AND BUSINESS

FOR PROMOTING THE GOODS AND SERVICES OF OTHERS BY PROVIDING A WEB SITE THAT FEATURES PRODUCT AND SERVICES REVIEWS, PRODUCT RECOMMENDATIONS, PRODUCT ENDORSEMENTS, PRODUCT RATINGS OF THE CONSUMER GOODS OF OTHERS, PURCHASE SOURCE INFORMATION, NAMELY, PRODUCT LINKS TO THE WEBSITES OF OTHERS, AND THE PROVISION OF ADVICE TO CONSUMERS REGARDING THE SELECTION OF PRODUCTS AND ITEMS TO BE PURCHASED, ALL IN THE FIELDS OF HUMANITARIAN EFFORTS, SOCIAL RESPONSIBILITY, SOCIAL JUSTICE, ENVIRONMENTAL CONSCIOUSNESS, SUSTAINABILITY AND CHARITABLE GIVING (U.S. CLS. 100, 101 AND 102).

CLASS 38—COMMUNICATION

FOR PROVIDING ON-LINE CHAT ROOMS AND ELECTRONIC BULLETIN BOARDS FOR TRANSMISSION OF MESSAGES AMONG USERS IN THE FIELDS OF HUMANITARIAN EFFORTS, SOCIAL RESPONSIBILITY, SOCIAL JUSTICE, ENVIRONMENTAL CONSCIOUSNESS, SUSTAINABILITY AND CHARITABLE GIVING (U.S. CLS. 100, 101 AND 104).

CLASS 41—EDUCATION AND ENTERTAINMENT

FOR PROVIDING A WEBSITE FEATURING BLOGS, ONLINE JOURNALS AND NON-DOWNLOADABLE PUBLICATIONS IN THE NATURE OF ARTICLES AND PRODUCT REVIEWS IN THE FIELDS OF HUMANITARIAN EFFORTS, SOCIAL RESPONSIBILITY, SOCIAL JUSTICE, ENVIRONMENTAL CONSCIOUSNESS, SUSTAINABILITY AND CHARITABLE GIVING; EDUCATION SERVICES, NAMELY, PROVIDING LIVE AND ON-LINE CLASSES, SEMINARS, WORKSHOPS IN THE FIELDS OF HUMANITARIAN EFFORTS, SOCIAL RESPONSIBILITY, SOCIAL JUSTICE, ENVIRONMENTAL CONSCIOUSNESS, SUSTAINABILITY AND CHARITABLE GIVING (U.S. CLS. 100, 101 AND 107).

JANET LEE, EXAMINING ATTORNEY

SN 85-278,584. PINNACLE PEAK HOLDING CORPORATION, DBA SETCOM CORPORATION, AUSTIN, TX. FILED 3-28-2011.

Setcom

THE MARK CONSISTS OF STANDARD CHARACTERS WITHOUT CLAIM TO ANY PARTICULAR FONT, STYLE, SIZE, OR COLOR.

CLASS 9—ELECTRICAL AND SCIENTIFIC APPARATUS

FOR COMMUNICATIONS HEADSETS FOR USE WITH COMMUNICATION RADIOS, INTERCOM SYSTEMS, AND OTHER COMMUNICATIONS NETWORK TRANSCEIVERS; COMMUNICATIONS HEADSETS WHICH PROVIDE HEARING PROTECTION AND ARE FOR USE WITH COMMUNICATION RADIOS, INTERCOM SYSTEMS, AND OTHER COMMUNICATIONS NETWORK TRANSCEIVERS; COMMUNICATIONS HEADSETS FOR USE WITH COMMUNICATION RADIOS, INTERCOM SYSTEMS, AND OTHER COMMUNICATIONS NETWORK TRANSCEIVERS; DEVICES FOR WIRELESS RADIO TRANSMISSION; INTERCOMS; SPEAKER-MICROPHONES FOR USE WITH COMMUNICATION RADIOS, INTERCOM SYSTEMS, AND OTHER COMMUNICATIONS NETWORK TRANSCEIVERS; DEVICES FOR CONTROLLING COMMUNICATION RADIOS AND INTERCOM SYSTEMS; PORTABLE RADIO ADAPTER CABLES; PUBLIC ADDRESS SYSTEM INTERFACE CABLES; TWO-WAY RADIO ADAPTER CABLES; MOBILE RADIO ADAPTER CABLES (U.S. CLS. 21, 23, 26, 36 AND 38).
FIRST USE 2-24-1972; IN COMMERCE 12-31-1972.

CLASS 37—CONSTRUCTION AND REPAIR

FOR REPAIR, MAINTENANCE, AND MODIFICATION TO ELECTRONIC EQUIPMENT, NAMELY, HEADSETS AND ACCESSORIES FOR RADIO COMMUNICATIONS AND INTERCOMS (U.S. CLS. 100, 103 AND 106).
FIRST USE 12-31-1972; IN COMMERCE 12-31-1972.
SHARON MEIER, EXAMINING ATTORNEY

SN 85-278,750. PARASOL LLC, NEW YORK, NY. FILED 3-28-2011.



THE MARK CONSISTS OF AN IMAGE OF THE TOP OF A SUN UMBRELLA COMPRISED OF THREE ALTERNATING BLACK AND WHITE CONCENTRIC OCTAGONS.

CLASS 3—COSMETICS AND CLEANING PREPARATIONS

FOR SUNSCREEN, SUNBLOCK, SUNTAN LOTIONS, AFTER SUN LOTIONS, COSMETIC PREPARATIONS FOR PROTECTING THE SKIN FROM THE SUN'S RAYS, NON-MEDICATED COSMETICS (U.S. CLS. 1, 4, 6, 50, 51 AND 52).

CLASS 9—ELECTRICAL AND SCIENTIFIC APPARATUS

FOR SUNGLASSES (U.S. CLS. 21, 23, 26, 36 AND 38).

CLASS 18—LEATHER GOODS

FOR BEACH BAGS, BEACH TOTE BAGS (U.S. CLS. 1, 2, 3, 22 AND 41).

CLASS 24—FABRICS

FOR BEACH TOWELS (U.S. CLS. 42 AND 50).

CLASS 35—ADVERTISING AND BUSINESS

FOR PROVIDING CONSUMER INFORMATION IN THE FIELD OF SUN PROTECTION PRODUCTS (U.S. CLS. 100, 101 AND 102).
TASNEEM HUSSAIN, EXAMINING ATTORNEY

SN 85-278,783. BRENTHAM, BRENT, TEMPLE, TX. FILED 3-28-2011.



THE MARK CONSISTS OF THE LITERAL ELEMENTS "360" WITH THREE ARC DESIGNS ABOVE THE "360".

CLASS 10—MEDICAL APPARATUS

FOR PHYSICAL EXERCISE APPARATUS, FOR MEDICAL PURPOSES (U.S. CLS. 26, 39 AND 44).
FIRST USE 8-15-2010; IN COMMERCE 8-15-2010.

CLASS 28—TOYS AND SPORTING GOODS

FOR MANUALLY-OPERATED EXERCISE EQUIPMENT FOR PHYSICAL FITNESS PURPOSES (U.S. CLS. 22, 23, 38 AND 50).
FIRST USE 8-15-2010; IN COMMERCE 8-15-2010.
JENNIFER MARTIN, EXAMINING ATTORNEY

SN 85-279,021. AZTEC SHOPS, LTD., SAN DIEGO, CA.
FILED 3-28-2011.

AZTEC SHOPS

THE MARK CONSISTS OF STANDARD CHARACTERS WITHOUT CLAIM TO ANY PARTICULAR FONT, STYLE, SIZE, OR COLOR.

OWNER OF U.S. REG. NOS. 2,436,672 AND 3,630,919.
NO CLAIM IS MADE TO THE EXCLUSIVE RIGHT TO USE "SHOPS", APART FROM THE MARK AS SHOWN.

CLASS 35—ADVERTISING AND BUSINESS

FOR RETAIL STORE AND ON-LINE RETAIL STORE SERVICES FEATURING SPORT TEAM, UNIVERSITY, AND FRATERNITY AND SORORITY CLOTHING, SOUVENIRS, GIFTS, AND TEXTBOOKS (U.S. CLS. 100, 101 AND 102).

FIRST USE 1-1-1974; IN COMMERCE 1-1-1974.

CLASS 43—HOTEL AND RESTAURANT SERVICES

FOR PROVIDING TEMPORARY HOUSING ACCOMMODATIONS; RESTAURANT AND CATERING SERVICES (U.S. CLS. 100 AND 101).

FIRST USE 1-1-1974; IN COMMERCE 1-1-1974.

JEAN IM, EXAMINING ATTORNEY

SN 85-279,075. CREAGRI, INC., HAYWARD, CA. FILED 3-28-2011.

OLEAVIA

THE MARK CONSISTS OF STANDARD CHARACTERS WITHOUT CLAIM TO ANY PARTICULAR FONT, STYLE, SIZE, OR COLOR.

THE WORDING "OLEAVIA" HAS NO MEANING IN A FOREIGN LANGUAGE.

CLASS 3—COSMETICS AND CLEANING PREPARATIONS

FOR AFTER-SUN LOTIONS; AGE RETARDANT LOTION; ANTIBACTERIAL SKIN SOAPS; BODY LOTION; COSMETIC CREAMS FOR SKIN CARE; COSMETIC PREPARATIONS FOR PROTECTING THE SKIN FROM THE SUN'S RAYS; COSMETIC PREPARATIONS FOR SKIN CARE; COSMETIC PREPARATIONS FOR SKIN RENEWAL; COSMETIC SUNTAN LOTIONS; FACE AND BODY LOTIONS; HAIR CARE LOTIONS; HAND LOTIONS; MOISTURIZING PREPARATIONS FOR THE SKIN; WRINKLE REMOVING SKIN CARE PREPARATIONS (U.S. CLS. 1, 4, 6, 50, 51 AND 52).

CLASS 5—PHARMACEUTICALS

FOR MEDICATED LOTIONS FOR TREATING DERMATOLOGICAL CONDITIONS; MEDICATED SKIN CARE PREPARATIONS; MEDICATED SKIN CARE PREPARATIONS, NAMELY, CREAMS, LOTIONS, GELS, TONERS, CLEANERS AND PEELS; MEDICATED SUNBURN LOTIONS; MEDICINAL CREAMS FOR SKIN CARE; PHARMACEUTICAL PREPARATIONS FOR SKIN CARE; PHARMACEUTICAL SKIN LOTIONS (U.S. CLS. 6, 18, 44, 46, 51 AND 52).

KATHERINE E. HALMEN, EXAMINING ATTORNEY

SN 85-279,089. FRIAL INC, PALO ALTO, CA. FILED 3-28-2011.

decadent bites

THE MARK CONSISTS OF STANDARD CHARACTERS WITHOUT CLAIM TO ANY PARTICULAR FONT, STYLE, SIZE, OR COLOR.

NO CLAIM IS MADE TO THE EXCLUSIVE RIGHT TO USE "BITES", APART FROM THE MARK AS SHOWN.

CLASS 29—MEATS AND PROCESSED FOODS

FOR FROZEN PRE-PACKAGED ENTREES CONSISTING PRIMARILY OF SEAFOOD; FROZEN ENTREES CONSISTING PRIMARILY OF MEAT, FISH, POULTRY OR VEGETABLES; FROZEN VEGETABLE-BASED ENTREES (U.S. CL. 46).

FIRST USE 9-21-2010; IN COMMERCE 9-21-2010.

CLASS 30—STAPLE FOODS

FOR FROZEN ENTREES CONSISTING PRIMARILY OF PASTA OR RICE (U.S. CL. 46).

JAMES LOVELACE, EXAMINING ATTORNEY

SN 85-280,280. R360 ENVIRONMENTAL SOLUTIONS, INC., HOUSTON, TX. FILED 3-29-2011.



NO CLAIM IS MADE TO THE EXCLUSIVE RIGHT TO USE "ENVIRONMENTAL SOLUTIONS", APART FROM THE MARK AS SHOWN.

THE MARK CONSISTS OF "R360" WITH A SLANTED CIRCLE THAT HAS AN ARROW ON ONE END AND THE CIRCLE IS HALF SOLID AND THE OTHER HALF IS PARTIALLY SHADED; THE CIRCLE/ARROW GOES THROUGH THE "0" AND AROUND THE BACK OF THE "6", WITH THE ARROW ALMOST CONNECTING WITH OTHER END OF THE CIRCLE IN FRONT OF AND SLIGHTLY BELOW THE "0"; UNDERNEATH THE "R" AND THE "3" ARE THE WORDS "ENVIRONMENTAL SOLUTIONS", WITH THE WORD "SOLUTIONS" UNDERNEATH THE WORD "ENVIRONMENTAL".

CLASS 37—CONSTRUCTION AND REPAIR

FOR WASTE OIL COLLECTION FOR RECYCLING (U.S. CLS. 100, 103 AND 106).
FIRST USE 0-0-2010; IN COMMERCE 0-0-2010.

CLASS 39—TRANSPORTATION AND STORAGE

FOR RECYCLED WATER DISTRIBUTION SERVICES FOR OTHERS (U.S. CLS. 100 AND 105).
FIRST USE 0-0-2010; IN COMMERCE 0-0-2010.

CLASS 40—MATERIAL TREATMENT

FOR ENVIRONMENTAL REMEDIATION SERVICES, NAMELY, WASTE AND WATER TREATMENT SERVICES; PROVISION OF INFORMATION, ADVICE AND CONSULTANCY IN RELATION TO THE PRODUCTION OF ENERGY, AND THE TREATMENT, MANAGEMENT, RECYCLING, TRANSFORMATION AND INCINERATION OF WASTE; RECYCLING; RECYCLING OF WASTE; SUSTAINABLE ON-SITE WATER RECYCLING AND WASTEWATER TREATMENT SERVICES; TREATMENT OF WASTE WATER; WASTE WATER REPROCESSING; WASTE WATER TREATMENT SERVICES; WASTE WATER TREATMENT SERVICES FOR INDUSTRIAL PURPOSES; WATER RECYCLING AND DESALINATION SERVICES (U.S. CLS. 100, 103 AND 106).
FIRST USE 0-0-2010; IN COMMERCE 0-0-2010.

DEIRDRE ROBERTSON, EXAMINING ATTORNEY

SN 85-280,423. KOG-LU USA, INC., DBA KILL3RCOMBO, LAKE FOREST, CA. FILED 3-29-2011.



THE COLOR(S) MUSTARD YELLOW, ORANGE, DARK ORANGE, BLUE, BLUE-PURPLE, PURPLE AND BLACK IS/ ARE CLAIMED AS A FEATURE OF THE MARK.

THE MARK CONSISTS OF BRUSH STROKES OF THE CAPITAL LETTERS "KILL" WITH THE COLOR MUSTARD YELLOW AND EACH LETTER OUTLINED IN BLACK; THE FIRST LETTER "L" SITS IMMEDIATELY BELOW THE SECOND LETTER "L"; ADJACENT TO THE SECOND LETTER "L" IS THE BRUSH STROKE NUMBER "3" IN ORANGE AND OUTLINED IN BLACK, ADJACENT TO THE NUMBER "3" IS THE BRUSH STROKE CAPITAL LETTER "R" IN DARK ORANGE OUTLINED IN BLACK. BELOW "KILL3R" IS THE WORD "COMBO" IN BRUSH STROKES, WITH THE CAPITAL LETTER "C" OVERLAPPING PART OF THE LETTER "K". BOTTOM HALF OF THE LETTER "C" IS IN BLUE, OUTLINED IN BLACK, AND THE COLOR BLUE GRADUALLY CHANGING TO BLUE-PURPLE. ADJACENT TO THE LETTER "C" IS THE LETTER "O" IN BLUE AND OUTLINED IN BLACK. ADJACENT TO THE LETTER "O" IS THE LETTER "M", WITH THE BOTTOM HALF OF THE LETTER "M" IN BLUE AND THE COLOR GRADUALLY TURNING FROM BLUE-PURPLE TO PURPLE. ADJACENT TO THE LETTER "M" IS THE CAPITAL LETTER "B", WITH THE BOTTOM ONE-THIRD OF THE LETTER IN BLUE AND THE COLOR GRADUALLY CHANGING FROM BLUE-PURPLE AND PURPLE AT THE TOP; ADJACENT TO THE LETTER "B" IS THE CAPITAL LETTER "O", WITH THE BOTTOM HALF OF THE LETTER IN BLUE AND GRADUALLY CHANGING FROM BLUE-PURPLE TO PURPLE. BLACK DOTS RESEMBLING PAINT SPLATTER ARE LOCATED RANDOMLY ALONG THE PERIPHERY OF AND BEHIND SOME OF THE LETTERING.

CLASS 38—COMMUNICATION

FOR PROVIDING AN ON-LINE FORUM FOR TRANSMISSION OF MESSAGES AMONG ONLINE COMPUTER GAME PLAYERS CONCERNING COMPUTER GAMES, TIPS, TECHNIQUES, SKILLS, AND EVENTS (U.S. CLS. 100, 101 AND 104).
FIRST USE 7-1-2010; IN COMMERCE 11-1-2010.

CLASS 41—EDUCATION AND ENTERTAINMENT

FOR ENTERTAINMENT SERVICES, NAMELY, ARRANGING AND CONDUCTING OF COMPETITIONS FOR ONLINE COMPUTER GAMES; ENTERTAINMENT SERVICES, NAMELY, PROVIDING ONLINE VIDEO GAMES (U.S. CLS. 100, 101 AND 107).
FIRST USE 7-1-2010; IN COMMERCE 11-1-2010.

GRETCHEN ULRICH, EXAMINING ATTORNEY

SN 85-281,578. ROBBINS-GIOIA, LLC, ALEXANDRIA, VA. FILED 3-30-2011.



OWNER OF U.S. REG. NOS. 3,127,472 AND 3,313,010.
THE MARK CONSISTS OF A TRIANGLE WITH THREE SMALLER TRIANGLES FORMING ANOTHER TRIANGLE INSIDE OF IT.

CLASS 9—ELECTRICAL AND SCIENTIFIC APPARATUS

FOR COMPUTER SOFTWARE FOR USE IN PROJECT MANAGEMENT SUPPORT COMPRISING TRACKING, REPORTING, MODELING, PLANNING, SCHEDULING, AND CHARTING; ELECTRONIC PUBLICATIONS, NAMELY, WHITE PAPERS, REPORTS, JOURNALS, GUIDES, AND PERIODICALS IN THE FIELD OF PROGRAM AND PROJECT MANAGEMENT RECORDED ON COMPUTER MEDIA (U.S. CLS. 21, 23, 26, 36 AND 38).
FIRST USE 1-0-2002; IN COMMERCE 1-0-2002.

CLASS 16—PAPER GOODS AND PRINTED MATTER

FOR PUBLICATIONS, NAMELY, WHITE PAPERS, RESEARCH REPORTS, JOURNALS, GUIDES, AND PERIODICALS IN THE FIELDS OF PROJECT, PROGRAM, AND PORTFOLIO MANAGEMENT (U.S. CLS. 2, 5, 22, 23, 29, 37, 38 AND 50).
FIRST USE 11-0-2002; IN COMMERCE 11-0-2002.

CLASS 35—ADVERTISING AND BUSINESS

FOR BUSINESS CONSULTATION, NAMELY, PROGRAM AND PROJECT MANAGEMENT CONSULTATION FOR OTHERS (U.S. CLS. 100, 101 AND 102).
FIRST USE 1-0-2002; IN COMMERCE 1-0-2002.

CLASS 41—EDUCATION AND ENTERTAINMENT

FOR EDUCATIONAL SERVICES, NAMELY, PROVIDING COURSES IN THE FIELD OF PROJECT MANAGEMENT; TRAINING SERVICES IN THE FIELD OF PROJECT MANAGEMENT AND DISTRIBUTION OF TRAINING MATERIALS IN CONNECTION THEREWITH (U.S. CLS. 100, 101 AND 107).

FIRST USE 9-0-2001; IN COMMERCE 9-0-2001.

CLASS 42—SCIENTIFIC AND COMPUTER SERVICES

FOR PROVIDING COMPUTER PROJECT MANAGEMENT SERVICES (U.S. CLS. 100 AND 101).

FIRST USE 1-0-2002; IN COMMERCE 1-0-2002.

HEATHER THOMPSON, EXAMINING ATTORNEY

SN 85-281,596. LUCIANO SABER, INC., VAN NUYS, CA. FILED 3-30-2011.

Aspiring Hollywood

THE MARK CONSISTS OF STANDARD CHARACTERS WITHOUT CLAIM TO ANY PARTICULAR FONT, STYLE, SIZE, OR COLOR.

NO CLAIM IS MADE TO THE EXCLUSIVE RIGHT TO USE "HOLLYWOOD", APART FROM THE MARK AS SHOWN.

CLASS 9—ELECTRICAL AND SCIENTIFIC APPARATUS

FOR DOWNLOADABLE PODCASTS AND WEBINARS IN THE FIELD OF THE TELEVISION AND FILM INDUSTRY (U.S. CLS. 21, 23, 26, 36 AND 38).

FIRST USE 5-3-2009; IN COMMERCE 5-3-2009.

CLASS 41—EDUCATION AND ENTERTAINMENT

FOR ENTERTAINMENT AND EDUCATIONAL SERVICES, NAMELY, THE PRESENTATION OF SEMINARS, WORKSHOPS, AND PANEL DISCUSSIONS, IN THE FIELD OF THE TELEVISION AND FILM INDUSTRY (U.S. CLS. 100, 101 AND 107).

FIRST USE 5-3-2009; IN COMMERCE 5-3-2009.

NICHOLAS ALTREE, EXAMINING ATTORNEY

SN 85-281,639. FRAGRANCE INTERNATIONAL, INC., YOUNGSTOWN, OH. FILED 3-30-2011.

KISS & TELL

THE MARK CONSISTS OF STANDARD CHARACTERS WITHOUT CLAIM TO ANY PARTICULAR FONT, STYLE, SIZE, OR COLOR.

OWNER OF U.S. REG. NOS. 2,942,310 AND 3,362,516.

CLASS 18—LEATHER GOODS

FOR ATHLETIC BAGS, ALL PURPOSE ATHLETIC BAGS, BACKPACKS, BARREL BAGS, BOOK BAGS, CLUTCH BAGS, DUFFEL BAGS, GYM BAGS, MESH SHOPPING BAGS, OVERNIGHT BAGS, SCHOOL BOOK BAGS, SCHOOL BAGS, TRAVELING BAGS, GARMENT BAGS FOR TRAVEL, SHOE BAGS FOR TRAVEL, BUSINESS CARD CASES, CALLING CARD CASES, CREDIT CARD CASES, COSMETIC CASES SOLD EMPTY, TOILETRY CASES SOLD EMPTY, CLUTCH PURSES, PURSES, DOG COLLARS, DOG LEASHES, HANDBAGS, KEY CASES, KNAPSACKS, LEASHES FOR ANIMALS, LUGGAGE, LUGGAGE TAGS, OVERNIGHT CASES, BRIEFCASE-TYPE PORTFOLIOS, TEXTILE SHOPPING BAGS, UMBRELLA COVERS, UMBRELLAS, BEACH UMBRELLAS, VANITY CASES SOLD EMPTY, AND WALLETS (U.S. CLS. 1, 2, 3, 22 AND 41).

CLASS 25—CLOTHING

FOR CLOTHING, NAMELY, ANKLETS, ATHLETIC SHOES, BANDANNAS, HEAD BANDS, NECK BANDS, SWEAT BANDS, WRIST BANDS, BATHING SUITS, BATHROBES, BEACH COVER-UPS, BEACHWEAR, BELTS, BIKINIS, BLAZERS, BLOUSES, BODY SHAPERS, BODY SUITS, BOXER SHORTS, BRAS, BRASSIERES, BRIEFS, CAFTANS, CARDIGANS, COATS, SPORT COATS, CORSELETS, CORSETS, ATHLETIC FOOTWEAR, FOUNDATION GARMENTS, GARTER BELTS, GLOVES, NIGHT GOWNS, GYM SHORTS, HALTER TOPS, HOSIERY, JEANS, JERSEYS, KERCHIEFS, KIMONOS, KNIT SHIRTS, LEOTARDS, LINGERIE, LOUNGEWEAR, MINISKIRTS, MITTENS, NEGLIGEEES, NIGHT SHIRTS, PAJAMAS, PANTIES, SWEAT PANTS, PARKAS, POLO SHIRTS, PONCHOS, ROBES, SCARVES, SHIRTS, SPORT SHIRTS, SWEAT SHIRTS, UNDERSHIRTS, SHORTS, SWEAT SHORTS, SLACKS, SLEEPWEAR, SOCKS, GYM SUITS, JOGGING SUITS, SWEAT SUITS, WARM-UP SUITS, SUN VISORS, SUSPENDERS, SWEATERS, TURTLENECK SWEATERS, V-NECK SWEATERS, SWIM TRUNKS, SWIM WEAR, SWIMSUITS, TANK TOPS, TEDDIES, TENNIS WEAR, TIGHTS, TOPS, TRACK SUITS, BATHING TRUNKS, TURTLENECKS, TUXEDOS, UNDERCLOTHES, UNDER GARMENTS, UNDERPANTS, UNDERWEAR, VISORS, AND WIND RESISTANT JACKETS (U.S. CLS. 22 AND 39).

MAUREEN DALL, EXAMINING ATTORNEY

SN 85-281,761. MORNING SONG GARDENS, LLC, AKA MORNING SONG GARDENS, CHAGRIN FALLS, OH. FILED 3-30-2011.



THE MARK CONSISTS OF A BEEHIVE SITTING ON A BENCH IN A FIELD WITH OUTLINING, WITH SUNFLOWERS ON EITHER SIDE, WITH A SKY ABOVE CLOUDS IN THE BACKGROUND, AND BEES FLYING AROUND THE TOP OF THE BEEHIVE, WITH THE MARK OUTLINED WITH AN INNER BORDER AND AN OUTER BORDER, AND WITH THE TERM "MORNING SONG GARDENS" IN A CURVED MANNER ABOVE THE DESIGN.

CLASS 3—COSMETICS AND CLEANING PREPARATIONS

FOR ALMOND SOAPS; AROMATIC BODY CARE PRODUCTS, NAMELY, BODY LOTION, SHOWER GEL, CUTICLE CREAM, SHAMPOO, CONDITIONER, NON-MEDICATED LIP BALM, SOAP, BODY POLISH, BODY AND FOOT SCRUB AND NON-MEDICATED FOOT CREAM; BABY HAND SOAP; BABY LOTION; BAR SOAP; BATH LOTION; BATH SOAPS; BATH SOAPS IN LIQUID, SOLID OR GEL FORM; BATHING LOTIONS; BEAUTY LOTIONS; BODY CREAM SOAP; BODY LOTION; BODY LOTIONS; CREAM SOAPS; FACE AND BODY LOTIONS; FACE MILK AND LOTIONS; FACIAL LOTION; HAIR CARE LOTIONS; HAIR LOTION; HAIR LOTIONS; HAND LOTIONS; HAND SOAPS; LIP BALM; LIQUID SOAPS; LIQUID SOAPS FOR HANDS AND FACE; LIQUID SOAPS FOR HANDS, FACE AND BODY; LOTIONS FOR FACE AND BODY CARE; MOISTURIZING CREAMS; MOISTURIZING MILKS; MOISTURIZING PREPARATIONS FOR THE SKIN; MOISTURIZING SOLUTIONS FOR THE SKIN; NON-MEDICATED HERBAL BODY CARE PRODUCTS, NAMELY, BODY OILS, SALVES, AND LIP BALMS; NON-MEDICATED SKIN CARE CREAMS AND LOTIONS; PERFUMED SOAP; PERFUMED SOAPS; SCENTED AND UNSCENTED BODY LOTIONS AND CREAMS; SHAVING BALM; SHAVING LOTION; SKIN CARE PREPARATIONS, NAMELY, BODY BALM; SKIN CLEANSING LOTION; SKIN LOTION; SKIN LOTIONS; SKIN MOISTURIZER; SKIN MOISTURIZER MASKS; SKIN SOAP; SOAPS FOR BODY CARE; SOAPS FOR PERSONAL USE (U.S. CLS. 1, 4, 6, 50, 51 AND 52).

FIRST USE 6-1-2008; IN COMMERCE 6-1-2008.

CLASS 4—LUBRICANTS AND FUELS

FOR CANDLES; CANDLES MADE OF BEES WAX; BEESWAX BARS (U.S. CLS. 1, 6 AND 15).

FIRST USE 6-1-2008; IN COMMERCE 6-1-2008.

MARY BOAGNI, EXAMINING ATTORNEY

SN 85-282,326. MAE VENTURES, INC., CHICAGO, IL. FILED 3-31-2011.

The Gob Shop

THE MARK CONSISTS OF STANDARD CHARACTERS WITHOUT CLAIM TO ANY PARTICULAR FONT, STYLE, SIZE, OR COLOR.

NO CLAIM IS MADE TO THE EXCLUSIVE RIGHT TO USE "SHOP", APART FROM THE MARK AS SHOWN.

CLASS 25—CLOTHING

FOR CLOTHING, NAMELY, APRONS, BANDANAS, BLOUSES, BOXER SHORTS, CAPS, HATS, HEAD WEAR, JERSEYS, KERCHIEFS, POLO SHIRTS, PULLOVERS, SCARVES, SUN VISORS, SWEAT PANTS, SWEAT SHIRTS, SWEAT SUITS, T-SHIRTS, TANK TOPS (U.S. CLS. 22 AND 39).

CLASS 30—STAPLE FOODS

FOR BREAD, ROLLS, BISCUITS, PIES, COOKIES, CAKES, PASTRY AND OTHER BAKERY GOODS, NAMELY, WHOOPIE PIES (U.S. CL. 46).

TIMOTHY FINNEGAN, EXAMINING ATTORNEY

SN 85-282,607. WISH UPON A HERO, LLC, VOORHEES, NJ. FILED 3-31-2011.

Charity Builder

THE MARK CONSISTS OF STANDARD CHARACTERS WITHOUT CLAIM TO ANY PARTICULAR FONT, STYLE, SIZE, OR COLOR.

NO CLAIM IS MADE TO THE EXCLUSIVE RIGHT TO USE "CHARITY", APART FROM THE MARK AS SHOWN.

CLASS 42—SCIENTIFIC AND COMPUTER SERVICES

FOR CHARITABLE SERVICES, NAMELY, PROVIDING A WEBSITE THAT FEATURES TECHNOLOGY THAT ENABLES FAMILIES, SCHOOLS, AND ORGANIZATIONS TO RAISE AND COLLECT MONEY BY CONNECTING THEM TO A SOCIAL HELPING WEBSITE (U.S. CLS. 100 AND 101).

FIRST USE 3-14-2011; IN COMMERCE 3-14-2011.

CLASS 45—PERSONAL AND LEGAL SERVICES

FOR CHARITABLE SERVICES, NAMELY, GRANTING WISHES OF FAMILIES IN NEED, SCHOOLS IN NEED OF FUNDS, NAMELY, FOR ART SUPPLIES, ATHLETIC EQUIPMENT, AND EDUCATIONAL RESOURCES TO ENHANCE A STUDENT'S LEARNING POTENTIAL, AND NON-PROFIT ORGANIZATIONS (U.S. CLS. 100 AND 101).

FIRST USE 3-14-2011; IN COMMERCE 3-14-2011.

WILLIAM VERHOSEK, EXAMINING ATTORNEY

SN 85-282,999. MIRAGE RESORTS INCORPORATED, LAS VEGAS, NV. FILED 3-31-2011.

STINGRAY COVE AT THE MIRAGE

THE MARK CONSISTS OF STANDARD CHARACTERS WITHOUT CLAIM TO ANY PARTICULAR FONT, STYLE, SIZE, OR COLOR.

OWNER OF U.S. REG. NOS. 1,870,054, 3,173,048 AND OTHERS.

NO CLAIM IS MADE TO THE EXCLUSIVE RIGHT TO USE "STINGRAY", APART FROM THE MARK AS SHOWN.

CLASS 35—ADVERTISING AND BUSINESS

FOR PROMOTING PUBLIC AWARENESS OF THE IMPORTANCE OF SEA LIFE CONSERVATION (U.S. CLS. 100, 101 AND 102).

CLASS 41—EDUCATION AND ENTERTAINMENT

FOR ANIMAL EXHIBITIONS (U.S. CLS. 100, 101 AND 107).

HAI-LY LAM, EXAMINING ATTORNEY

SN 85-283,003. MIRAGE RESORTS INCORPORATED, LAS VEGAS, NV. FILED 3-31-2011.

SN 85-284,174. PAPERLINX NORTH AMERICA, INC., SANTA FE SPRINGS, CA. FILED 4-1-2011.

STINGRAY COVE

THE MARK CONSISTS OF STANDARD CHARACTERS WITHOUT CLAIM TO ANY PARTICULAR FONT, STYLE, SIZE, OR COLOR.

NO CLAIM IS MADE TO THE EXCLUSIVE RIGHT TO USE "STINGRAY", APART FROM THE MARK AS SHOWN.

CLASS 35—ADVERTISING AND BUSINESS

FOR PROMOTING PUBLIC AWARENESS OF THE IMPORTANCE OF SEA LIFE CONSERVATION (U.S. CLS. 100, 101 AND 102).

CLASS 41—EDUCATION AND ENTERTAINMENT

FOR ANIMAL EXHIBITIONS (U.S. CLS. 100, 101 AND 107).

HAI-LY LAM, EXAMINING ATTORNEY

SN 85-283,026. MIRAGE RESORTS INCORPORATED, LAS VEGAS, NV. FILED 3-31-2011.



OWNER OF U.S. REG. NOS. 1,870,054, 3,173,048 AND OTHERS.

NO CLAIM IS MADE TO THE EXCLUSIVE RIGHT TO USE "STINGRAY", APART FROM THE MARK AS SHOWN.

THE MARK CONSISTS OF THE WORDING "STINGRAY COVE" WITH A DEPICTION OF A STINGRAY SWIMMING BETWEEN THE WORDING AND WITH THE STINGRAY'S TAIL OVERLAPPING WITH THE LETTER "Y" IN "STINGRAY" AND THE LETTER "C" IN "COVE". UNDERNEATH OF THE FOREGOING APPEARS THE WORDING "AT THE MIRAGE".

CLASS 35—ADVERTISING AND BUSINESS

FOR PROMOTING PUBLIC AWARENESS OF THE IMPORTANCE OF SEA LIFE CONSERVATION (U.S. CLS. 100, 101 AND 102).

CLASS 41—EDUCATION AND ENTERTAINMENT

FOR ANIMAL EXHIBITIONS (U.S. CLS. 100, 101 AND 107).

HAI-LY LAM, EXAMINING ATTORNEY



THE MARK CONSISTS OF THE TERM "ECOMOJO". THE LETTERS "E" AND "M" ARE CAPITALIZED. TWO LEAVES SPROUT FROM THE TOP OF THE LETTER "J".

CLASS 16—PAPER GOODS AND PRINTED MATTER

FOR PAPER, BOARD AND PAPER PRODUCTS, NAMELY, COMMERCIAL PRINTING PAPERS AND PAPERBOARD (U.S. CLS. 2, 5, 22, 23, 29, 37, 38 AND 50).

CLASS 35—ADVERTISING AND BUSINESS

FOR PROVIDING CONSUMER INFORMATION IN THE FIELD OF PAPER PRODUCTS AND SUSTAINABLE PAPER PRODUCTS (U.S. CLS. 100, 101 AND 102).

CLASS 40—MATERIAL TREATMENT

FOR PROVIDING ELECTRONIC INFORMATION IN THE FIELD OF PAPER TREATMENT, PAPER RECYCLING (U.S. CLS. 100, 103 AND 106).

CLASS 41—EDUCATION AND ENTERTAINMENT

FOR PROVIDING ON-LINE NEWSLETTERS IN THE FIELDS OF PAPER PRODUCTS, ENVIRONMENTAL ISSUES AND SUSTAINABILITY IN CONNECTION WITH THE PAPER INDUSTRY; PROVIDING ONLINE PUBLICATIONS IN THE NATURE OF BLOGS, NEWSLETTERS AND ARTICLES IN THE FIELDS OF PAPER PRODUCTS, ENVIRONMENTAL ISSUES AND SUSTAINABILITY IN CONNECTION WITH THE PAPER INDUSTRY; ON-LINE BLOGS FEATURING PAPER PRODUCTS, ENVIRONMENTAL ISSUES AND SUSTAINABILITY IN CONNECTION WITH THE PAPER INDUSTRY (U.S. CLS. 100, 101 AND 107).

CLASS 42—SCIENTIFIC AND COMPUTER SERVICES

FOR PROVIDING A WEB SITE FEATURING INFORMATION ABOUT GLOBAL WARMING AND ITS EFFECT ON NATURE AND THE ENVIRONMENT; PROVIDING TECHNOLOGICAL INFORMATION ABOUT ENVIRONMENTALLY-CONSCIOUS AND GREEN INNOVATIONS (U.S. CLS. 100 AND 101).

MATTHEW EINSTEIN, EXAMINING ATTORNEY

SN 85-284,604. VISION SOURCE L.P., KINGWOOD, TX. FILED 4-2-2011.

OWNER OF U.S. REG. NOS. 1,738,869 AND 3,302,317.

NO CLAIM IS MADE TO THE EXCLUSIVE RIGHT TO USE "VISION", APART FROM THE MARK AS SHOWN.
THE MARK CONSISTS OF THE WORDS "VISION SOURCE" APPEARING IN A STYLIZED FONT.

CLASS 35—ADVERTISING AND BUSINESS

FOR RETAIL STORE SERVICES FEATURING OPTICAL PRODUCTS, INCLUDING EYEGLASSES, EYEGLASS FRAMES, EYEGLASS LENSES, CONTACT LENSES, AND ACCESSORIES (U.S. CLS. 100, 101 AND 102).

CLASS 44—MEDICAL, BEAUTY AND AGRICULTURAL SERVICES

FOR OPTICIAN AND OPTOMETRY SERVICES (U.S. CLS. 100 AND 101).
KATHERINE STOIDES, EXAMINING ATTORNEY

SN 85-285,004. LONG MOTOR CORPORATION, LENEXA, KS. FILED 4-4-2011.

RESTORE... MAINTAIN... CUSTOMIZE

THE MARK CONSISTS OF STANDARD CHARACTERS WITHOUT CLAIM TO ANY PARTICULAR FONT, STYLE, SIZE, OR COLOR.

CLASS 16—PAPER GOODS AND PRINTED MATTER

FOR PRINTED CATALOGS IN THE FIELD OF AUTOMOBILE, TRUCK, AND VAN PARTS AND ACCESSORIES (U.S. CLS. 2, 5, 22, 23, 29, 37, 38 AND 50).
FIRST USE 2-0-2010; IN COMMERCE 2-0-2010.

CLASS 35—ADVERTISING AND BUSINESS

FOR MAIL ORDER AND ELECTRONIC CATALOG SERVICES IN THE FIELD OF AUTOMOBILE, TRUCK, AND VAN PARTS AND ACCESSORIES (U.S. CLS. 100, 101 AND 102).
FIRST USE 2-0-2010; IN COMMERCE 2-0-2010.
DARRYL SPRUILL, EXAMINING ATTORNEY

SN 85-285,180. WEATHERFORD/LAMB, INC., HOUSTON, TX. FILED 4-4-2011.

THE NEW GENERATION SERVICE COMPANY

THE MARK CONSISTS OF STANDARD CHARACTERS WITHOUT CLAIM TO ANY PARTICULAR FONT, STYLE, SIZE, OR COLOR.
NO CLAIM IS MADE TO THE EXCLUSIVE RIGHT TO USE "SERVICE COMPANY", APART FROM THE MARK AS SHOWN.

CLASS 37—CONSTRUCTION AND REPAIR

FOR CLEANING OF EQUIPMENT AT OIL AND GAS REFINERIES, OIL AND GAS PRODUCTION FACILITIES, CHEMICAL PRODUCTION PLANTS AND OIL AND GAS COMPRESSOR STATIONS, NAMELY, CLEANING OF VESSELS, SEPARATORS, PLATFORM JACKETS, SURFACES FOR PREPARATION AND TUBULARS USED IN THE OIL AND GAS INDUSTRY; OIL AND GAS INDUSTRIAL MACHINE CLEANING SERVICES; PIPELINE CONSTRUCTION AND MAINTENANCE; PIPELINE INSTALLATION AND REPAIR; PRESSURE WASHING SERVICES; RENTAL OF GAS OR AIR COMPRESSORS; REPAIR OR MAINTENANCE OF STORAGE TANKS; REPAIR OR MAINTENANCE OF VESSELS; TECHNICAL CONSULTING RELATED TO THE INSTALLATION OF OIL AND GAS EQUIPMENT, CONTROL SYSTEMS, AND MACHINERY (U.S. CLS. 100, 103 AND 106).
FIRST USE 12-31-2003; IN COMMERCE 12-31-2003.

CLASS 40—MATERIAL TREATMENT

FOR OIL PRODUCTION SERVICES; RENTAL OF WATER TREATMENT EQUIPMENT (U.S. CLS. 100, 103 AND 106).
FIRST USE 12-31-2003; IN COMMERCE 12-31-2003.

CLASS 42—SCIENTIFIC AND COMPUTER SERVICES

FOR DESIGN/PLANNING AND ENGINEERING OF COMPRESSED-AIR STATIONS; ENGINEERING; OIL WELL TESTING; PIPELINE INSPECTION SERVICES; TESTING, ANALYSIS AND EVALUATION OF THE GOODS AND SERVICES OF OTHERS FOR THE PURPOSE OF CERTIFICATION (U.S. CLS. 100 AND 101).
FIRST USE 12-31-2003; IN COMMERCE 12-31-2003.
MATTHEW MCDOWELL, EXAMINING ATTORNEY

SN 85-285,401. BATH & BODY WORKS BRAND MANAGEMENT, INC., REYNOLDSBURG, OH. FILED 4-4-2011.

SCENTPORTABLE GRIP

THE MARK CONSISTS OF STANDARD CHARACTERS WITHOUT CLAIM TO ANY PARTICULAR FONT, STYLE, SIZE, OR COLOR.
OWNER OF U.S. REG. NO. 3,541,672.
NO CLAIM IS MADE TO THE EXCLUSIVE RIGHT TO USE "GRIP", APART FROM THE MARK AS SHOWN.

CLASS 3—COSMETICS AND CLEANING PREPARATIONS

FOR FRAGRANCE REFILLS FOR NON-ELECTRIC ROOM AND CAR FRAGRANCE DISPENSERS, ROOM FRAGRANCE GELS, CAR FRAGRANCE GELS (U.S. CLS. 1, 4, 6, 50, 51 AND 52).

CLASS 5—PHARMACEUTICALS

FOR CAR DEODORIZER, ROOM FRESHENERS (U.S. CLS. 6, 18, 44, 46, 51 AND 52).
BARBARA RUTLAND, EXAMINING ATTORNEY

SN 85-286,034. MOON MEN DJS, LLC, IRONDALE, AL.
FILED 4-5-2011.



THE COLOR(S) BLACK AND GREEN IS/ARE CLAIMED AS A FEATURE OF THE MARK.

THE MARK CONSISTS OF THE LETTERS "UVEE" IN BLACK WITH GREEN INSIDE THE TWO OPENINGS OF "EE" AND A BLACK AND GREEN UNDERLINE OF "VEE". EACH "E" ALSO HAS FOUR BLACK EYELASHES ON TOP OF THEM. THE LETTERS "TV" ARE BLACK AND INSIDE A GREEN RECTANGULAR BOX THAT IS OUTLINED IN BLACK AND HAS TWO BLACK ANTENNAS ON TOP OF IT. THE ".COM" IS WRITTEN VERTICALLY IN BLACK WITH GREEN IN THE OPENING OF THE "O".

CLASS 9—ELECTRICAL AND SCIENTIFIC APPARATUS

FOR AUDIO AND VIDEO RECORDINGS FEATURING MUSIC AND ARTISTIC PERFORMANCES; AUDIO AND VIDEO RECORDINGS FEATURING SHOPS, INDIVIDUALS, RESTAURANTS, BUSINESSES, SERVICES, SELF-PROMOTION, FASHION AND INSTRUCTION; DIGITAL MEDIA, NAMELY, PRE-RECORDED DVDS, DOWNLOADABLE AUDIO AND VIDEO RECORDINGS, AND CDS FEATURING AND PROMOTING SHOPS, INDIVIDUALS, RESTAURANTS, BUSINESSES, SERVICES, SELF-PROMOTION, FASHION AND INSTRUCTION; DIGITAL MEDIA, NAMELY, PRE-RECORDED VIDEO CASSETTES, DIGITAL VIDEO DISCS, DIGITAL VERSATILE DISCS, DOWNLOADABLE AUDIO AND VIDEO RECORDINGS, DVDS, AND HIGH DEFINITION DIGITAL DISCS FEATURING SHOPS, INDIVIDUALS, RESTAURANTS, BUSINESSES, SERVICES, SELF-PROMOTION, FASHION AND INSTRUCTION; DOWNLOADABLE VIDEO RECORDINGS FEATURING SHOPS, INDIVIDUALS, RESTAURANTS, BUSINESSES, SERVICES, SELF-PROMOTION, FASHION AND INSTRUCTION; VIDEO RECORDINGS FEATURING SHOPS, INDIVIDUALS, RESTAURANTS, BUSINESSES, SERVICES, SELF-PROMOTION, FASHION AND INSTRUCTION (U.S. CLS. 21, 23, 26, 36 AND 38).

FIRST USE 3-30-2011; IN COMMERCE 3-30-2011.

CLASS 41—EDUCATION AND ENTERTAINMENT

FOR AUDIO AND VIDEO RECORDING SERVICES; PRODUCTION OF SOUND AND MUSIC VIDEO RECORDINGS; VIDEO RECORDING SERVICES (U.S. CLS. 100, 101 AND 107).

FIRST USE 3-30-2011; IN COMMERCE 3-30-2011.
KATINA MISTER, EXAMINING ATTORNEY

SN 85-286,124. HERSHEY CHOCOLATE & CONFECTIONERY CORPORATION, WHEAT RIDGE, CO. FILED 4-5-2011.

MINTENSITY

THE MARK CONSISTS OF STANDARD CHARACTERS WITHOUT CLAIM TO ANY PARTICULAR FONT, STYLE, SIZE, OR COLOR.

OWNER OF U.S. REG. NO. 3,360,337.

CLASS 3—COSMETICS AND CLEANING PREPARATIONS

FOR BREATH FRESHENING CONFECTIONARY, NAMELY, BREATH MINTS AND CANDY (U.S. CLS. 1, 4, 6, 50, 51 AND 52).

CLASS 30—STAPLE FOODS

FOR CANDY MINTS (U.S. CL. 46).
JACQUELINE A. LAVINE, EXAMINING ATTORNEY

SN 85-286,283. COVANTA ENERGY CORPORATION, MORRISTOWN, NJ. FILED 4-5-2011.

REF FUEL

THE MARK CONSISTS OF STANDARD CHARACTERS WITHOUT CLAIM TO ANY PARTICULAR FONT, STYLE, SIZE, OR COLOR.

OWNER OF U.S. REG. NO. 1,602,911.
NO CLAIM IS MADE TO THE EXCLUSIVE RIGHT TO USE "FUEL", APART FROM THE MARK AS SHOWN.

CLASS 4—LUBRICANTS AND FUELS

FOR BIOFUELS, DIESEL FUEL (U.S. CLS. 1, 6 AND 15).

CLASS 11—ENVIRONMENTAL CONTROL APPARATUS

FOR WASTE TREATMENT EQUIPMENT FOR THE CONVERSION OF WASTE TO FUEL (U.S. CLS. 13, 21, 23, 31 AND 34).

REBECCA SMITH, EXAMINING ATTORNEY

SN 85-286,400. SOUND KITCHEN AND BATH L L C, MUKILTEO, WA. FILED S.R. 4-5-2011; AM. P.R. 7-20-2011.

SOUND KITCHEN AND BATH

THE MARK CONSISTS OF STANDARD CHARACTERS WITHOUT CLAIM TO ANY PARTICULAR FONT, STYLE, SIZE, OR COLOR.

NO CLAIM IS MADE TO THE EXCLUSIVE RIGHT TO USE "KITCHEN AND BATH", APART FROM THE MARK AS SHOWN.

CLASS 19—NON-METALLIC BUILDING MATERIALS

FOR NONSTRUCTURAL BUILDING MATERIALS, NAMELY, GRANITE USED IN DECORATIVE SURFACE APPLICATIONS FOR COUNTERTOPS AND VANITY TOPS (U.S. CLS. 1, 12, 33 AND 50).

FIRST USE 8-1-2009; IN COMMERCE 10-19-2009.

CLASS 20—FURNITURE AND ARTICLES NOT OTHERWISE CLASSIFIED

FOR BATHROOM VANITIES; KITCHEN CABINETS (U.S. CLS. 2, 13, 22, 25, 32 AND 50).
FIRST USE 8-1-2009; IN COMMERCE 10-19-2009.
KIMBERLY PERRY, EXAMINING ATTORNEY

SN 85-286,916. HALLMARK LICENSING, INC., KANSAS CITY, MO. FILED 4-5-2011.

CHRISTOPHER

THE MARK CONSISTS OF STANDARD CHARACTERS WITHOUT CLAIM TO ANY PARTICULAR FONT, STYLE, SIZE, OR COLOR.

THE NAME(S), PORTRAIT(S), AND/OR SIGNATURE(S) SHOWN IN THE MARK DOES NOT IDENTIFY A PARTICULAR LIVING INDIVIDUAL.

SN 85-286,843. CELANESE INTERNATIONAL CORPORATION, DALLAS, TX. FILED 4-5-2011.

TCX**CLASS 16—PAPER GOODS AND PRINTED MATTER**

FOR CHILDREN'S BOOKS, CHILDREN'S ACTIVITY BOOKS (U.S. CLS. 2, 5, 22, 23, 29, 37, 38 AND 50).

CLASS 28—TOYS AND SPORTING GOODS

FOR PLUSH TOYS AND ACCESSORIES THEREFOR, DOLLS AND ACCESSORIES THEREFOR (U.S. CLS. 22, 23, 38 AND 50).

BERYL GARDNER, EXAMINING ATTORNEY

THE MARK CONSISTS OF STANDARD CHARACTERS WITHOUT CLAIM TO ANY PARTICULAR FONT, STYLE, SIZE, OR COLOR.

CLASS 1—CHEMICALS

FOR CHEMICALS, NAMELY, ALCOHOL AND ETHANOL FOR INDUSTRIAL PURPOSES (U.S. CLS. 1, 5, 6, 10, 26 AND 46).

SN 85-287,077. LUCENT GROUP INCORPORATED, TAMPA, FL. FILED 4-5-2011.

LUCENT GROUP**CLASS 4—LUBRICANTS AND FUELS**

FOR ETHANOL CONTAINING FUELS, ALCOHOL, AND MIXED ALCOHOL FUELS; BIO FUELS; NATURAL GAS DERIVED FUEL; COAL DERIVED FUEL; PETROLEUM; COKE DERIVED FUEL; ALTERNATIVE FUEL PRODUCTS, NAMELY, RENEWABLE FUELS, BIO-DIESEL, AND BIO-ALCOHOL (U.S. CLS. 1, 6 AND 15).

THE MARK CONSISTS OF STANDARD CHARACTERS WITHOUT CLAIM TO ANY PARTICULAR FONT, STYLE, SIZE, OR COLOR.

NO CLAIM IS MADE TO THE EXCLUSIVE RIGHT TO USE "GROUP", APART FROM THE MARK AS SHOWN.

CLASS 40—MATERIAL TREATMENT

FOR CHEMICAL PROCESSING AND PRODUCTION, NAMELY, PRODUCTION, TREATMENT AND REFINEMENT OF ALCOHOL, ETHANOL, FUELS, NATURAL GAS, AND BIO-FUELS FOR OTHERS; ALCOHOL, ETHANOL, AND BIOMASS FERMENTATION AND GASIFICATION SERVICES; WASTE TREATMENT AND RECYCLING SERVICES; NATURAL GAS LIQUEFACTION SERVICES; FUEL AND OIL REFINING (U.S. CLS. 100, 103 AND 106).

CLASS 39—TRANSPORTATION AND STORAGE

FOR MANAGEMENT OF VEHICULAR TRAFFIC FLOW THROUGH ADVANCED COMMUNICATIONS NETWORK AND TECHNOLOGY; PROVIDING ROAD AND TRAFFIC INFORMATION; TRAFFIC INFORMATION SERVICES; TRANSPORTATION CONSULTING SERVICES; TRANSPORTATION INFORMATION (U.S. CLS. 100 AND 105).

FIRST USE 7-19-2005; IN COMMERCE 7-19-2005.

CLASS 42—SCIENTIFIC AND COMPUTER SERVICES

FOR RESEARCH AND DEVELOPMENT IN THE FIELD OF CHEMICALS, NAMELY, ALCOHOL, ETHANOL, BIOFUELS; SCIENTIFIC AND TECHNOLOGICAL CONSULTING AND RESEARCH SERVICES IN THE FIELD OF ALCOHOL, ETHANOL, BIOFUEL, NATURAL GAS, WASTE, AND PETROLEUM COKE RESEARCH AND DESIGN; RESEARCH DEVELOPMENT AND DESIGN RELATED TO CHEMICAL PLANTS; ENGINEERING SERVICES IN THE FIELD OF FUEL BLENDING, WASTE HANDLING, AND CHEMICAL DISTRIBUTION (U.S. CLS. 100 AND 101).

H. M. FISHER, EXAMINING ATTORNEY

CLASS 42—SCIENTIFIC AND COMPUTER SERVICES

FOR COMPUTER SERVICES, NAMELY, MONITORING THE PERFORMANCE OF PARTICIPANTS AT SPORTING EVENTS BY TRACKING A COMPUTER CHIP WORN BY A SPORTING PARTICIPANT; CUSTOMIZED SOFTWARE DEVELOPMENT IN THE FIELD OF TRAFFIC AND TRANSPORTATION; TRAFFIC PLANNING SERVICES; TRANSPORTATION AND TRAFFIC PLANNING SERVICES; UPDATING OF COMPUTER SOFTWARE RELATING TO COMPUTER SECURITY AND PREVENTION OF COMPUTER RISKS (U.S. CLS. 100 AND 101).

FIRST USE 7-19-2005; IN COMMERCE 7-19-2005.
KIM SAITO, EXAMINING ATTORNEY

SN 85-287,086. MIRAGE RESORTS INCORPORATED, LAS VEGAS, NV. FILED 4-5-2011.



NO CLAIM IS MADE TO THE EXCLUSIVE RIGHT TO USE "STINGRAY", APART FROM THE MARK AS SHOWN.

THE MARK CONSISTS OF THE WORDING "STINGRAY COVE" WITH A DEPICTION OF A STINGRAY SWIMMING BETWEEN THE WORDING AND WITH THE STINGRAY'S TAIL OVERLAPPING WITH THE LETTER "Y" IN "STINGRAY" AND THE LETTER "C" IN "COVE".

CLASS 35—ADVERTISING AND BUSINESS

FOR PROMOTING PUBLIC AWARENESS OF THE IMPORTANCE OF SEA LIFE CONSERVATION (U.S. CLS. 100, 101 AND 102).

CLASS 41—EDUCATION AND ENTERTAINMENT

FOR ANIMAL EXHIBITIONS (U.S. CLS. 100, 101 AND 107).

HAI-LY LAM, EXAMINING ATTORNEY

SN 85-288,776. UNITED STATES TENNIS ASSOCIATION INCORPORATED, WHITE PLAINS, NY. FILED 4-7-2011.

ADVANCE YOUR GAME

THE MARK CONSISTS OF THE WORDS "ADVANCE YOUR GAME" IN STYLIZED LETTERS.

CLASS 25—CLOTHING

FOR CLOTHING, NAMELY, DRESS SHIRTS, SKIRTS, DRESSES, COLLARED SHIRTS, SPORTS SHIRTS, T-SHIRTS, TANK TOPS, PANTS, SHORTS, WARM-UP SUITS, SWEAT SHIRTS, SWEAT PANTS, SWEATERS, VESTS, FLEECE TOPS, FLEECE BOTTOMS, JACKETS, TIES, HATS, CAPS, VISORS, HEADBANDS, WRISTBANDS AND SOCKS (U.S. CLS. 22 AND 39).

CLASS 35—ADVERTISING AND BUSINESS

FOR PROMOTING PUBLIC INTEREST IN THE SPORT OF TENNIS AMONG YOUNG ADULTS (U.S. CLS. 100, 101 AND 102).

CLASS 41—EDUCATION AND ENTERTAINMENT

FOR TEACHING YOUNG ADULTS THE SPORT OF TENNIS AND CONDUCTING TENNIS TOURNAMENTS, CONTESTS, CLINICS AND WORKSHOPS AMONG YOUNG ADULTS (U.S. CLS. 100, 101 AND 107).

CHARLES L. JENKINS, EXAMINING ATTORNEY

SN 85-288,829. UNITED STATES TENNIS ASSOCIATION INCORPORATED, WHITE PLAINS, NY. FILED 4-7-2011.

ADVANCE YOUR GAME

THE COLOR(S) BLUE IS/ARE CLAIMED AS A FEATURE OF THE MARK.

THE MARK CONSISTS OF THE WORDS "ADVANCE YOUR GAME" IN STYLIZED BLUE LETTERS.

CLASS 25—CLOTHING

FOR CLOTHING, NAMELY, DRESS SHIRTS, SKIRTS, DRESSES, COLLARED SHIRTS, SPORTS SHIRTS, T-SHIRTS, TANK TOPS, PANTS, SHORTS, WARM-UP SUITS, SWEAT SHIRTS, SWEAT PANTS, SWEATERS, VESTS, FLEECE TOPS, FLEECE BOTTOMS, JACKETS, TIES, HATS, CAPS, VISORS, HEADBANDS, WRISTBANDS AND SOCKS (U.S. CLS. 22 AND 39).

CLASS 35—ADVERTISING AND BUSINESS

FOR PROMOTING PUBLIC INTEREST IN THE SPORT OF TENNIS AMONG YOUNG ADULTS (U.S. CLS. 100, 101 AND 102).

CLASS 41—EDUCATION AND ENTERTAINMENT

FOR TEACHING YOUNG ADULTS THE SPORT OF TENNIS AND CONDUCTING TENNIS TOURNAMENTS, CONTESTS, CLINICS AND WORKSHOPS AMONG YOUNG ADULTS (U.S. CLS. 100, 101 AND 107).

CHARLES L. JENKINS, EXAMINING ATTORNEY

SN 85-289,086. GMJ DESIGN, LLC, WEST PALM BEACH, FL. FILED 4-7-2011.

TotalPonics

THE MARK CONSISTS OF STANDARD CHARACTERS WITHOUT CLAIM TO ANY PARTICULAR FONT, STYLE, SIZE, OR COLOR.

CLASS 7—MACHINERY

FOR ELECTRIC PUMPS (U.S. CLS. 13, 19, 21, 23, 31, 34 AND 35).

CLASS 21—HOUSEWARES AND GLASS

FOR HYDROPONIC GARDEN KIT FOR HOME USE COMPRISING GROWING CONTAINERS AND ALSO INCLUDING HYDROPONIC FERTILIZERS, SEEDS, SUBSTRATE, DRAIN COMPONENTS, A BOOK AND STARTING CLASS OF DVD AND CD INSTRUCTIONAL MATERIALS (U.S. CLS. 2, 13, 23, 29, 30, 33, 40 AND 50).

SHAUNIA CARLYLE, EXAMINING ATTORNEY

SN 85-289,513. HOME HEALTH HOLDINGS, INC., DALLAS, TX. FILED 4-7-2011.

ASPIRE HOME CARE

THE MARK CONSISTS OF STANDARD CHARACTERS WITHOUT CLAIM TO ANY PARTICULAR FONT, STYLE, SIZE, OR COLOR.

NO CLAIM IS MADE TO THE EXCLUSIVE RIGHT TO USE "HOME CARE", APART FROM THE MARK AS SHOWN.

CLASS 44—MEDICAL, BEAUTY AND AGRICULTURAL SERVICES

FOR HOME HEALTH CARE SERVICES; SKILLED NURSING SERVICES; HOSPICE CARE SERVICES; PALLIATIVE CARE SERVICES (U.S. CLS. 100 AND 101).

FIRST USE 2-1-2006; IN COMMERCE 8-28-2006.

CLASS 45—PERSONAL AND LEGAL SERVICES

FOR SOCIAL SERVICES, NAMELY, COMPANIONSHIP SERVICES FOR THE ELDERLY AND DISABLED; PROVIDING NON-MEDICAL PERSONAL ASSISTANT SERVICES FOR OTHERS IN THE NATURE OF PLANNING, ORGANIZING, COORDINATING, ARRANGING AND ASSISTING INDIVIDUALS TO PERFORM DAILY TASKS; PERSONAL CARE ASSISTANCE OF ACTIVITIES OF DAILY LIVING, SUCH AS BATHING, GROOMING AND PERSONAL MOBILITY FOR OTHERS; RUNNING ERRANDS FOR OTHERS (U.S. CLS. 100 AND 101).

FIRST USE 2-1-2006; IN COMMERCE 8-28-2006.

ALEXANDER L. POWERS, EXAMINING ATTORNEY

SN 85-289,528. HOME HEALTH HOLDINGS, INC., DALLAS, TX. FILED 4-7-2011.

ASPIRE HOSPICE

THE MARK CONSISTS OF STANDARD CHARACTERS WITHOUT CLAIM TO ANY PARTICULAR FONT, STYLE, SIZE, OR COLOR.

NO CLAIM IS MADE TO THE EXCLUSIVE RIGHT TO USE "HOSPICE", APART FROM THE MARK AS SHOWN.

CLASS 44—MEDICAL, BEAUTY AND AGRICULTURAL SERVICES

FOR HOME HEALTH CARE SERVICES; SKILLED NURSING SERVICES; HOSPICE CARE SERVICES; PALLIATIVE CARE SERVICES (U.S. CLS. 100 AND 101).

CLASS 45—PERSONAL AND LEGAL SERVICES

FOR SOCIAL SERVICES, NAMELY, COMPANIONSHIP SERVICES FOR THE ELDERLY AND DISABLED; PROVIDING NON-MEDICAL PERSONAL ASSISTANT SERVICES FOR OTHERS IN THE NATURE OF PLANNING, ORGANIZING, COORDINATING, ARRANGING AND ASSISTING INDIVIDUALS TO PERFORM DAILY TASKS; PERSONAL CARE ASSISTANCE OF ACTIVITIES OF DAILY LIVING, SUCH AS BATHING, GROOMING AND PERSONAL MOBILITY FOR OTHERS; RUNNING ERRANDS FOR OTHERS (U.S. CLS. 100 AND 101).

ALEXANDER L. POWERS, EXAMINING ATTORNEY

SN 85-289,799. SENZEYE INDUSTRIES, LLC, EAST GREENWICH, CT. FILED 4-8-2011.



THE MARK CONSISTS OF AN OVAL; TWO FOOTPRINTS LOCATED WITHIN THE OVAL; A "SPROUTABOUT" TERM LOCATED WITHIN THE OVAL AND ABOVE THE FOOTPRINTS; AND A SPROUT LOCATED MOSTLY WITHIN THE OVAL, BUT PARTIALLY ABOVE IT.

CLASS 9—ELECTRICAL AND SCIENTIFIC APPARATUS

FOR BABY MONITORS; COMPUTER HARDWARE AND SOFTWARE SYSTEM FOR TRACKING PEOPLE, OBJECTS AND PETS USING GPS DATA ON A DEVICE ON THE TRACKED PEOPLE, OBJECTS AND PETS; VIDEO MONITORS (U.S. CLS. 21, 23, 26, 36 AND 38).

CLASS 10—MEDICAL APPARATUS

FOR NASAL ASPIRATORS; THERMOMETERS FOR MEDICAL PURPOSES (U.S. CLS. 26, 39 AND 44).

CLASS 20—FURNITURE AND ARTICLES NOT OTHERWISE CLASSIFIED

FOR BABY WALKERS; FURNITURE; INFANT WALKERS (U.S. CLS. 2, 13, 22, 25, 32 AND 50).

CLASS 21—HOUSEWARES AND GLASS

FOR COMBS; CUPS; HAIR BRUSHES (U.S. CLS. 2, 13, 23, 29, 30, 33, 40 AND 50).

CLASS 25—CLOTHING

FOR BABY BIBS NOT OF PAPER; BIBS NOT OF PAPER (U.S. CLS. 22 AND 39).

GENE MACIOL, EXAMINING ATTORNEY

SN 85-289,827. GAMORET, LLC, WESTLAKE VILLAGE, CA.
FILED 4-8-2011.

LA MORET

THE MARK CONSISTS OF STANDARD CHARACTERS WITHOUT CLAIM TO ANY PARTICULAR FONT, STYLE, SIZE, OR COLOR.

CLASS 30—STAPLE FOODS

FOR CAKES; CHOCOLATE AND CHOCOLATES; PASTRIES; SANDWICHES (U.S. CL. 46).

CLASS 43—HOTEL AND RESTAURANT SERVICES

FOR RESTAURANT AND BAR SERVICES (U.S. CLS. 100 AND 101).
GENE MACIOL, EXAMINING ATTORNEY

SN 85-289,900. COMMERCIAL METALS COMPANY, IRVING, TX. FILED 4-8-2011.

COMMERCIAL METALS COMPANY

THE MARK CONSISTS OF STANDARD CHARACTERS WITHOUT CLAIM TO ANY PARTICULAR FONT, STYLE, SIZE, OR COLOR.

NO CLAIM IS MADE TO THE EXCLUSIVE RIGHT TO USE "COMPANY", APART FROM THE MARK AS SHOWN. SEC. 2(F).

CLASS 6—METAL GOODS

FOR FULL LINE OF METALS IN SHEET, ROD, BAR, ANGLE, ROUND, BEAM, CASTELLATED BEAM, CELLULAR BEAM, FLAT BEAM, JOIST, STRIP, TUBE, PLATE, BILLET, SQUARE, AND WIRE FORM; METAL ALLOYS FOR USE IN INDUSTRY; METAL SCRAPS FOR USE IN INDUSTRY; METALLIC FENCE POSTS AND SIGN POSTS; METAL KEYSTOCK; METAL COIN BLANKS; METAL POWDERS USED IN MANUFACTURING; REFRACTORY CONSTRUCTION MATERIALS OF METAL (U.S. CLS. 2, 12, 13, 14, 23, 25 AND 50).
FIRST USE 0-0-1960; IN COMMERCE 0-0-1960.

CLASS 35—ADVERTISING AND BUSINESS

FOR RETAIL STORE SERVICES AND DISTRIBUTORSHIPS FEATURING METALS, SCRAP METAL, CHEMICALS, USED AUTOMOBILE PARTS, CONSTRUCTION PRODUCTS, AND ACCESSORIES; PROVIDING BUSINESS CONSULTATION SERVICES IN BUSINESS SOLUTIONS, BUSINESS MARKETING, PROCESSING, SIZING, LOGISTICS, CHARTERING, DISTRIBUTION, INTERNATIONAL DOCUMENTATION, AND CREATIVE SOLUTIONS ADVICE TO BUYERS AND SELLERS IN THE FIELD OF COMMODITY EXCHANGE (U.S. CLS. 100, 101 AND 102).
FIRST USE 0-0-1960; IN COMMERCE 0-0-1960.

CLASS 40—MATERIAL TREATMENT

FOR RECYCLING; MILL WORKING; METAL FABRICATION SERVICES; METAL HEAT TREATING SERVICES BY MEANS OF QUENCH AND TEMPER, NORMALIZING AND ANNEALING TO PRODUCE STEELS FOR USE IN ARCTIC SERVICE, OFF-SHORE RIGS, TRUCKING, HEAVY CRANES AND MINING EQUIPMENT (U.S. CLS. 100, 103 AND 106).
FIRST USE 0-0-1960; IN COMMERCE 0-0-1960.
GRETTA YAO, EXAMINING ATTORNEY

SN 85-289,904. COMMERCIAL METALS COMPANY, IRVING, TX. FILED 4-8-2011.



THE MARK CONSISTS OF A STYLIZED GLOBE WITH A BANNER CONTAINING THE LETTERS "CMC".

CLASS 6—METAL GOODS

FOR FULL LINE OF METALS IN SHEET, ROD, BAR, ANGLE, ROUND, BEAM, CASTELLATED BEAM, CELLULAR BEAM, FLAT BEAM, JOIST, STRIP, TUBE, PLATE, BILLET, SQUARE, AND WIRE FORM; METAL ALLOYS FOR USE IN INDUSTRY; METAL SCRAPS FOR USE IN INDUSTRY; METALLIC FENCE POSTS AND SIGN POSTS; METAL KEYSTOCK; METAL COIN BLANKS; METAL POWDERS USED IN MANUFACTURING; REFRACTORY CONSTRUCTION MATERIALS OF METAL (U.S. CLS. 2, 12, 13, 14, 23, 25 AND 50).
FIRST USE 0-0-1967; IN COMMERCE 0-0-1967.

CLASS 35—ADVERTISING AND BUSINESS

FOR RETAIL STORE SERVICES AND DISTRIBUTORSHIPS FEATURING METALS, SCRAP METAL, CHEMICALS, USED AUTOMOBILE PARTS, CONSTRUCTION PRODUCTS, AND ACCESSORIES; PROVIDING BUSINESS CONSULTATION SERVICES IN BUSINESS SOLUTIONS, BUSINESS MARKETING, PROCESSING, SIZING, LOGISTICS, CHARTERING, DISTRIBUTION, INTERNATIONAL DOCUMENTATION, AND CREATIVE SOLUTIONS ADVICE TO BUYERS AND SELLERS IN THE FIELD OF COMMODITY EXCHANGE (U.S. CLS. 100, 101 AND 102).
FIRST USE 0-0-1967; IN COMMERCE 0-0-1967.

CLASS 40—MATERIAL TREATMENT

FOR RECYCLING; MILL WORKING; METAL FABRICATION SERVICES; METAL HEAT TREATING SERVICES BY MEANS OF QUENCH AND TEMPER, NORMALIZING AND ANNEALING TO PRODUCE STEELS FOR USE IN ARCTIC SERVICE, OFF-SHORE RIGS, TRUCKING, HEAVY CRANES AND MINING EQUIPMENT (U.S. CLS. 100, 103 AND 106).
FIRST USE 0-0-1967; IN COMMERCE 0-0-1967.
GRETTA YAO, EXAMINING ATTORNEY

SN 85-289,908. COMMERCIAL METALS COMPANY, IRVING, TX. FILED 4-8-2011.

CMC

THE MARK CONSISTS OF STANDARD CHARACTERS WITHOUT CLAIM TO ANY PARTICULAR FONT, STYLE, SIZE, OR COLOR.

CLASS 6—METAL GOODS

FOR FULL LINE OF METALS IN SHEET, ROD, BAR, ANGLE, ROUND, BEAM, CASTELLATED BEAM, CELLULAR BEAM, FLAT BEAM, JOIST, STRIP, TUBE, PLATE, BILLET, SQUARE, AND WIRE FORM; METAL ALLOYS FOR USE IN INDUSTRY; METAL SCRAPS FOR USE IN INDUSTRY; METALLIC FENCE POSTS AND SIGN POSTS; METAL KEYSTOCK; METAL COIN BLANKS; METAL POWDERS USED IN MANUFACTURING; REFRACTORY CONSTRUCTION MATERIALS OF METAL (U.S. CLS. 2, 12, 13, 14, 23, 25 AND 50).
FIRST USE 0-0-1960; IN COMMERCE 0-0-1960.

CLASS 35—ADVERTISING AND BUSINESS

FOR RETAIL STORE SERVICES AND DISTRIBUTORSHIPS FEATURING METALS, SCRAP METAL, CHEMICALS, USED AUTOMOBILE PARTS, CONSTRUCTION PRODUCTS, AND ACCESSORIES; PROVIDING BUSINESS CONSULTATION SERVICES IN BUSINESS SOLUTIONS, BUSINESS MARKETING, PROCESSING, SIZING, LOGISTICS, CHARTERING, DISTRIBUTION, INTERNATIONAL DOCUMENTATION, AND CREATIVE SOLUTIONS ADVICE TO BUYERS AND SELLERS IN THE FIELD OF COMMODITY EXCHANGE (U.S. CLS. 100, 101 AND 102).
FIRST USE 0-0-1960; IN COMMERCE 0-0-1960.

CLASS 40—MATERIAL TREATMENT

FOR RECYCLING; MILL WORKING; METAL FABRICATION SERVICES; METAL HEAT TREATING SERVICES BY MEANS OF QUENCH AND TEMPER, NORMALIZING AND ANNEALING TO PRODUCE STEELS FOR USE IN ARCTIC SERVICE, OFF-SHORE RIGS, TRUCKING, HEAVY CRANES AND MINING EQUIPMENT (U.S. CLS. 100, 103 AND 106).
FIRST USE 0-0-1960; IN COMMERCE 0-0-1960.
GRETTA YAO, EXAMINING ATTORNEY

SN 85-290,051. EAST MEADOW CORP., DBA UNCLE GIUSEPPE'S MARKETPLACE, EAST MEADOW, NY. FILED 4-8-2011.



OWNER OF U.S. REG. NO. 2,970,582.
NO CLAIM IS MADE TO THE EXCLUSIVE RIGHT TO USE "MARKETPLACE", APART FROM THE MARK AS SHOWN.

THE COLOR(S) BLACK, RED, LIGHT GREEN, DARK GREEN, GREY, PEACH, GOLD, AND BROWN IS/ARE CLAIMED AS A FEATURE OF THE MARK.

THE MARK CONSISTS OF THE LETTERING "UNCLE GIUSEPPE'S" WRITTEN IN BLACK, WITH THE "G" IN

"GIUSEPPE'S" IN A LARGER STYLIZED RED FONT, POSITIONED OVER THE WORD "MARKETPLACE" IN BLACK, ALONG WITH A PICTURE OF A MAN WITH PEACH COLOR SKIN AND HANDS, WITH GREY HAIR AND A MUSTACHE WEARING A RED SHIRT WITH GREEN SUSPENDERS AND GOLD BUCKLES AND A GREEN HAT, HOLDING A BROWN LOAF OF BREAD IN ONE HAND AND HOLDING ONE FINGER UP ON THE OTHER HAND, THE IMAGE OF THE MAN BEING POSITIONED ABOVE THE WORD "UNCLE".

CLASS 35—ADVERTISING AND BUSINESS

FOR RETAIL GROCERY STORE SERVICES (U.S. CLS. 100, 101 AND 102).
FIRST USE 11-1-2007; IN COMMERCE 11-1-2007.

CLASS 43—HOTEL AND RESTAURANT SERVICES

FOR CATERING SERVICES (U.S. CLS. 100 AND 101).
FIRST USE 11-1-2007; IN COMMERCE 11-1-2007.
DAWN HAN, EXAMINING ATTORNEY

SN 85-290,150. BODYFLASHWORLD, LLC, MIAMI, FL. FILED 4-8-2011.

BODYFLASHWORLD

THE MARK CONSISTS OF STANDARD CHARACTERS WITHOUT CLAIM TO ANY PARTICULAR FONT, STYLE, SIZE, OR COLOR.

CLASS 38—COMMUNICATION

FOR COMMUNICATIONS SERVICES, NAMELY, TRANSMITTING STREAMED SOUND AND AUDIOVISUAL RECORDINGS VIA THE INTERNET; STREAMING OF VIDEO MATERIAL ON THE INTERNET; VIDEO BROADCASTING SERVICES OVER THE INTERNET OR OTHER COMMUNICATIONS NETWORK FEATURING THE UPLOADED, POSTED AND TAGGED VIDEOS OF OTHERS (U.S. CLS. 100, 101 AND 104).

CLASS 41—EDUCATION AND ENTERTAINMENT

FOR ENTERTAINMENT SERVICES, NAMELY, PROVIDING A WEB SITE FEATURING NON-DOWNLOADABLE ADULT-THEMED PHOTOGRAPHS AND VIDEOS; ENTERTAINMENT SERVICES, NAMELY, PROVIDING VIRTUAL ENVIRONMENTS IN WHICH USERS CAN INTERACT FOR RECREATIONAL, LEISURE OR ENTERTAINMENT PURPOSES (U.S. CLS. 100, 101 AND 107).

CLASS 45—PERSONAL AND LEGAL SERVICES

FOR PROVIDING A SOCIAL NETWORKING WEBSITE FOR ENTERTAINMENT PURPOSES (U.S. CLS. 100 AND 101).
BRENDAN REGAN, EXAMINING ATTORNEY

SN 85-290,208. SUMITOMO CHEMICAL CO., LTD, TOKYO, JAPAN, FILED 4-8-2011.

KAMUY

THE MARK CONSISTS OF STANDARD CHARACTERS WITHOUT CLAIM TO ANY PARTICULAR FONT, STYLE, SIZE, OR COLOR.

CLASS 1—CHEMICALS

FOR CHEMICALS FOR USE IN THE MANUFACTURE OF FUNGICIDES, INSECTICIDES AND HERBICIDES (U.S. CLS. 1, 5, 6, 10, 26 AND 46).

CLASS 5—PHARMACEUTICALS

FOR FUNGICIDES, INSECTICIDES, HERBICIDES AND PREPARATIONS FOR KILLING WEEDS AND DESTROYING VERMIN (U.S. CLS. 6, 18, 44, 46, 51 AND 52).

JACQUELINE A. LAVINE, EXAMINING ATTORNEY

SN 85-290,213. CREAGRI, INC., HAYWARD, CA. FILED S.R. 4-8-2011; AM. P.R. 6-24-2011.

OLIVENOL *plus*⁺

THE MARK CONSISTS OF THE WORD "OLIVENOL" IN DARK, LARGE CAPITALIZED LETTERS. BELOW AND TO THE RIGHT SIDE OF THE WORD "OLIVENOL", THE WORD "PLUS" APPEARS IN LOWER CASE ITALICIZED FONT. JUST AFTER THE "S" IN "PLUS", AN ADDITION SYMBOL APPEARS IN SUPERSCRIPIT.

THE WORDING "OLIVENOL" PLUS HAS NO MEANING IN A FOREIGN LANGUAGE.

CLASS 1—CHEMICALS

FOR ANTIOXIDANTS AND PROTEINS USED IN THE MANUFACTURE OF COSMETICS, BEVERAGES, FOOD PRODUCTS AND FOOD SUPPLEMENTS (U.S. CLS. 1, 5, 6, 10, 26 AND 46).

FIRST USE 3-11-2011; IN COMMERCE 3-11-2011.

CLASS 5—PHARMACEUTICALS

FOR ANIMAL FEED SUPPLEMENTS; DIETARY AND NUTRITIONAL SUPPLEMENTS; DIETARY AND NUTRITIONAL SUPPLEMENTS CONTAINING OLIVE POLYPHENOLS; DIETARY AND NUTRITIONAL SUPPLEMENTS FOR ENDURANCE SPORTS; DIETARY BEVERAGE SUPPLEMENTS FOR HUMAN CONSUMPTION IN LIQUID AND DRY MIX FORM FOR THERAPEUTIC PURPOSES; DIETARY FOOD SUPPLEMENTS; DIETARY PET SUPPLEMENTS IN THE FORM OF PET TREATS; DIETARY SUPPLEMENT BEVERAGE FOR HUMANS; DIETARY SUPPLEMENTAL DRINKS; DIETARY SUPPLEMENTS; DIETARY SUPPLEMENTS FOR ANIMALS; DIETARY SUPPLEMENTS FOR CONTROLLING CHOLESTEROL; DIETARY SUPPLEMENTS FOR HUMAN CONSUMPTION; DIETARY SUPPLEMENTS FOR PETS; DIETARY SUPPLEMENTS FOR HUMANS; FOOD SUPPLEMENTS; FOOD SUPPLEMENTS, NAMELY, ANTI-OXIDANTS; LIQUID NUTRITIONAL SUPPLEMENT (U.S. CLS. 6, 18, 44, 46, 51 AND 52).

FIRST USE 3-11-2011; IN COMMERCE 3-11-2011.

KATHERINE E. HALMEN, EXAMINING ATTORNEY

SN 85-290,232. BAYER OY, 20210 TURKU, FINLAND, FILED 4-8-2011.

SOPHIQUE

THE MARK CONSISTS OF STANDARD CHARACTERS WITHOUT CLAIM TO ANY PARTICULAR FONT, STYLE, SIZE, OR COLOR.

CLASS 5—PHARMACEUTICALS

FOR PHARMACEUTICAL PREPARATIONS, NAMELY, HORMONAL PREPARATIONS FOR MEDICAL USE (U.S. CLS. 6, 18, 44, 46, 51 AND 52).

CLASS 10—MEDICAL APPARATUS

FOR MEDICAL DEVICE, NAMELY, AN INTRAUTERINE DEVICE FOR CONTRACEPTION (U.S. CLS. 26, 39 AND 44).

LINDA ESTRADA, EXAMINING ATTORNEY

SN 85-290,313. EAST MEADOW CORP., DBA UNCLE GIUSEPPE'S MARKETPLACE, EAST MEADOW, NY. FILED 4-8-2011.

UNCLE GIUSEPPE'S MARKETPLACE

THE MARK CONSISTS OF STANDARD CHARACTERS WITHOUT CLAIM TO ANY PARTICULAR FONT, STYLE, SIZE, OR COLOR.

OWNER OF U.S. REG. NO. 2,970,582.

NO CLAIM IS MADE TO THE EXCLUSIVE RIGHT TO USE "MARKETPLACE", APART FROM THE MARK AS SHOWN.

CLASS 35—ADVERTISING AND BUSINESS

FOR RETAIL GROCERY STORE SERVICES (U.S. CLS. 100, 101 AND 102).
FIRST USE 11-1-2007; IN COMMERCE 11-1-2007.

CLASS 43—HOTEL AND RESTAURANT SERVICES

FOR CATERING SERVICES (U.S. CLS. 100 AND 101).
FIRST USE 11-1-2007; IN COMMERCE 11-1-2007.
DAWN HAN, EXAMINING ATTORNEY

SN 85-290,424. GOLDSTEIN, STEVEN, WESTPORT, CT.
FILED 4-8-2011.

DAILYMEATLOAF

THE MARK CONSISTS OF STANDARD CHARACTERS WITHOUT CLAIM TO ANY PARTICULAR FONT, STYLE, SIZE, OR COLOR.

CLASS 35—ADVERTISING AND BUSINESS

FOR PROVIDING INFORMATION OVER THE INTERNET CONCERNING MEN'S ISSUES IN THE FIELDS OF BUSINESS MATTERS, CONSUMER PRODUCTS AND POLITICS (U.S. CLS. 100, 101 AND 102).

CLASS 41—EDUCATION AND ENTERTAINMENT

FOR PROVIDING INFORMATION OVER THE INTERNET CONCERNING MEN'S ISSUES IN THE FIELDS OF ENTERTAINMENT, POPULAR CULTURE, SPORTS, AND CURRENT EVENT REPORTING (U.S. CLS. 100, 101 AND 107).
LAKEISHA LEWIS, EXAMINING ATTORNEY

SN 85-290,453. THOMAS NELSON, INC., NASHVILLE, TN.
FILED 4-8-2011.

THE RULE OF 7

THE MARK CONSISTS OF STANDARD CHARACTERS WITHOUT CLAIM TO ANY PARTICULAR FONT, STYLE, SIZE, OR COLOR.

CLASS 9—ELECTRICAL AND SCIENTIFIC APPARATUS

FOR PRERECORDED AUDIO AND VIDEO DISCS AND CASSETTES FEATURING BOOKS AND RECORDED BOOKS ON COMPUTER MEDIA ALL FEATURING SERIES OF FICTION BOOKS AND SERIES OF NONFICTION BOOKS IN THE FIELDS OF RELIGION, BIOGRAPHIES, HISTORY, SPORTS, QUILTING, HUMOR, CHILDREN, POLITICAL, SELF-HELP REFERENCE AND COMMENTARY, BIBLES, COOKBOOKS; RECORDED BOOKS ON COMPUTER MEDIA FEATURING INSPIRATIONAL BOOKS AND HOW-TO BOOKS IN THE FIELDS OF RELIGION, BIOGRAPHIES, HISTORY, SPORTS, QUILTING, HUMOR, CHILDREN, POLITICAL, SELF-HELP REFERENCE AND COMMENTARY, BIBLES, COOKBOOKS; MOUSE PADS; ELECTRONIC PUBLICATIONS, NAMELY, BOOKS FEATURING BOOKS AND RECORDED BOOKS ON COMPUTER MEDIA FEATURING SERIES OF FICTION BOOKS AND SERIES OF NONFICTION BOOKS IN THE FIELDS OF RELIGION, BIOGRAPHIES, HISTORY, SPORTS, QUILTING, HUMOR, CHILDREN, POLITICAL, SELF-HELP REFERENCE AND COMMENTARY, BIBLES, COOKBOOKS; DOWNLOADABLE ELECTRONIC PUBLICATIONS, NAMELY, BOOKS FEATURING BOOKS AND RECORDED BOOKS ON COMPUTER MEDIA ALL FEATURING SERIES OF FICTION BOOKS AND SERIES OF NONFICTION BOOKS IN THE FIELDS OF RELIGION, BIOGRAPHIES, HISTORY, SPORTS, QUILTING, HUMOR, CHILDREN, POLITICAL, SELF-HELP REFERENCE AND COMMENTARY, BIBLES, COOKBOOKS (U.S. CLS. 21, 23, 26, 36 AND 38).

CLASS 16—PAPER GOODS AND PRINTED MATTER

FOR BOOKS FEATURING RELIGION, INSPIRATIONAL, RELIGIOUS, CHILDREN, HUMOR, POLITICAL, BIOGRAPHY, FICTION, NON-FICTION, SELF-HELP REFERENCE AND COMMENTARY; AND BIBLES (U.S. CLS. 2, 5, 22, 23, 29, 37, 38 AND 50).

CLASS 21—HOUSEWARES AND GLASS

FOR COFFEE MUGS (U.S. CLS. 2, 13, 23, 29, 30, 33, 40 AND 50).
ZACHARY BELLO, EXAMINING ATTORNEY

SN 85-290,606. BIKES BELONG COALITION, LTD., BOULDER, CO. FILED 4-8-2011.

BIKES BELONG

THE MARK CONSISTS OF STANDARD CHARACTERS WITHOUT CLAIM TO ANY PARTICULAR FONT, STYLE, SIZE, OR COLOR.

NO CLAIM IS MADE TO THE EXCLUSIVE RIGHT TO USE "BIKES", APART FROM THE MARK AS SHOWN.

CLASS 35—ADVERTISING AND BUSINESS

FOR PROMOTIONAL SPONSORSHIP OF BICYCLING EVENTS; POLITICAL ACTION COMMITTEE SERVICES, NAMELY, PROMOTING THE INTERESTS OF THE BICYCLE INDUSTRY AND PEOPLE AND ORGANIZATIONS INVOLVED AND CONCERNED WITH BICYCLING IN THE FIELD OF POLITICS AND LEGISLATION; LOBBYING SERVICES, NAMELY, PROMOTING THE INTERESTS OF THE BICYCLING INDUSTRY AND PEOPLE AND ORGANIZATIONS INVOLVED AND CONCERNED WITH BICYCLING IN THE FIELDS OF POLITICS, LEGISLATION, AND REGULATION; PROMOTING PUBLIC AWARENESS OF BICYCLING; PUBLIC ADVOCACY TO PROMOTE AND ENCOURAGE BICYCLE SAFETY, BICYCLING AND BICYCLE AWARENESS; PROVIDING INFORMATION ABOUT BICYCLING, BICYCLE USE, BICYCLE SAFETY AND BICYCLE ADVOCACY VIA THE INTERNET; RESEARCH, DATA GATHERING AND ANALYSIS OF BICYCLE SALES, BICYCLE USE AND THE HEALTH, ECONOMIC AND ENVIRONMENTAL BENEFITS OF BICYCLING (U.S. CLS. 100, 101 AND 102).

FIRST USE 11-30-1998; IN COMMERCE 11-30-1998.

CLASS 36—INSURANCE AND FINANCIAL

FOR PROVIDING GRANTS FOR BICYCLE ADVOCACY, BICYCLE AWARENESS, BICYCLE INFRASTRUCTURE AND BICYCLE RELATED PROJECTS; CHARITABLE FOUNDATION SERVICES, NAMELY, PROVIDING FINANCIAL ASSISTANCE FOR THE PROMOTION OF BICYCLE SAFETY, BICYCLING, BICYCLE ADVOCACY, BICYCLE AWARENESS AND BICYCLE INFRASTRUCTURE, AND BICYCLE RELATED PROJECTS; CHARITABLE FUNDRAISING TO SUPPORT BICYCLE SAFETY, BICYCLING, BICYCLE ADVOCACY, BICYCLE AWARENESS AND BICYCLE INFRASTRUCTURE, AND BICYCLE RELATED PROJECTS (U.S. CLS. 100, 101 AND 102).

FIRST USE 11-30-1998; IN COMMERCE 11-30-1998.
JEFF DEFORD, EXAMINING ATTORNEY

SN 85-290,702. DH SERVICES, LLC, NEW YORK, NY. FILED 4-8-2011.

MISTER

THE MARK CONSISTS OF STANDARD CHARACTERS WITHOUT CLAIM TO ANY PARTICULAR FONT, STYLE, SIZE, OR COLOR.

CLASS 9—ELECTRICAL AND SCIENTIFIC APPARATUS

FOR COMMUNICATIONS SOFTWARE FOR CONNECTING PEOPLE INTERESTED IN SOCIAL NETWORKING AND ONLINE DATING; COMPUTER APPLICATION SOFTWARE FOR MOBILE PHONES, NAMELY, SOFTWARE FOR SOCIAL NETWORKING AND ONLINE DATING; COMPUTER APPLICATION SOFTWARE FOR MOBILE PHONES AND HANDHELD COMPUTERS, NAMELY, SOFTWARE FOR SOCIAL NETWORKING AND ONLINE DATING (U.S. CLS. 21, 23, 26, 36 AND 38).

CLASS 42—SCIENTIFIC AND COMPUTER SERVICES

FOR APPLICATION SERVICE PROVIDER (ASP) FEATURING SOFTWARE FOR USE IN SOCIAL NETWORKING AND ONLINE DATING; COMPUTER SERVICE, NAMELY, ACTING AS AN APPLICATION SERVICE PROVIDER IN THE FIELD OF INFORMATION MANAGEMENT TO HOST COMPUTER APPLICATION SOFTWARE FOR THE PURPOSE OF SOCIAL NETWORKING AND ONLINE DATING; PROVIDING A WEBSITE FEATURING NON-DOWNLOADABLE SOFTWARE FOR SOCIAL NETWORKING AND ONLINE DATING (U.S. CLS. 100 AND 101).

CLASS 45—PERSONAL AND LEGAL SERVICES

FOR DATING SERVICES; DATING SERVICES, NAMELY, PROVIDING AN ON-LINE COMPUTER DATABASE FEATURING SINGLE PEOPLE INTERESTED IN MEETING OTHER SINGLE PEOPLE; INTERNET-BASED DATING, SOCIAL INTRODUCTION AND SOCIAL NETWORKING SERVICES; PROVIDING A SOCIAL NETWORKING WEBSITE FOR ENTERTAINMENT PURPOSES (U.S. CLS. 100 AND 101).
MICHELLE DUBOIS, EXAMINING ATTORNEY

SN 85-290,772. BARBARA MCVICKER, LLC, WORTHINGTON, OH. FILED 4-8-2011.

STUCK IN THE MIDDLE

THE MARK CONSISTS OF STANDARD CHARACTERS WITHOUT CLAIM TO ANY PARTICULAR FONT, STYLE, SIZE, OR COLOR.

CLASS 9—ELECTRICAL AND SCIENTIFIC APPARATUS

FOR (BASED ON INTENT TO USE) DVDS, CDS, DOWNLOADABLE MP3 FILES, DOWNLOADABLE MP3 RECORDINGS, DOWNLOADABLE WEBINARS, AND DOWNLOADABLE PODCASTS, ALL IN THE FIELD OF ELDER CARE (U.S. CLS. 21, 23, 26, 36 AND 38).

CLASS 16—PAPER GOODS AND PRINTED MATTER

FOR (BASED ON USE IN COMMERCE) PRINTED MATERIALS, NAMELY, BOOKS, WORKBOOKS, NOTEPADS, JOURNALS, AND CALENDARS, ALL FEATURING ELDER CARE TOPICS (U.S. CLS. 2, 5, 22, 23, 29, 37, 38 AND 50).

FIRST USE 9-12-2005; IN COMMERCE 2-0-2008.

CLASS 41—EDUCATION AND ENTERTAINMENT

FOR (BASED ON INTENT TO USE) CONDUCTING WORKSHOPS, SEMINARS, CLASSES, AND PRESENTATIONS IN THE FIELDS OF ELDER CARE; NON-FICTION TELEVISION PROGRAMMING IN THE FIELD OF ELDER CARE; THE PROVISION OF ON-LINE PUBLICATIONS IN THE NATURE OF E-BOOKS IN THE FIELD OF ELDER CARE (U.S. CLS. 100, 101 AND 107).

CLASS 43—HOTEL AND RESTAURANT SERVICES

FOR (BASED ON INTENT TO USE) PROVISION OF INTERNET WEBSITES FEATURING INFORMATION ABOUT ELDER CARE (U.S. CLS. 100 AND 101).

JANICE L. MCMORROW, EXAMINING ATTORNEY

SN 85-291,051. BENNETT, BRIAN, SAVANNAH, GA. FILED 4-9-2011.



SN 85-290,947. DH SERVICES, LLC, NEW YORK, NY. FILED 4-9-2011.

MR.

THE MARK CONSISTS OF STANDARD CHARACTERS WITHOUT CLAIM TO ANY PARTICULAR FONT, STYLE, SIZE, OR COLOR.

CLASS 9—ELECTRICAL AND SCIENTIFIC APPARATUS

FOR COMMUNICATIONS SOFTWARE FOR CONNECTING PEOPLE INTERESTED IN SOCIAL NETWORKING AND ONLINE DATING; COMPUTER APPLICATION SOFTWARE FOR MOBILE PHONES, NAMELY, SOFTWARE FOR SOCIAL NETWORKING AND ONLINE DATING; COMPUTER APPLICATION SOFTWARE FOR MOBILE PHONES AND HANDHELD COMPUTERS, NAMELY, SOFTWARE FOR SOCIAL NETWORKING AND ONLINE DATING (U.S. CLS. 21, 23, 26, 36 AND 38).

CLASS 42—SCIENTIFIC AND COMPUTER SERVICES

FOR APPLICATION SERVICE PROVIDER (ASP) FEATURING SOFTWARE FOR USE IN SOCIAL NETWORKING AND ONLINE DATING; COMPUTER SERVICE, NAMELY, ACTING AS AN APPLICATION SERVICE PROVIDER IN THE FIELD OF INFORMATION MANAGEMENT TO HOST COMPUTER APPLICATION SOFTWARE FOR THE PURPOSE OF SOCIAL NETWORKING AND ONLINE DATING; PROVIDING A WEBSITE FEATURING NON-DOWNLOADABLE SOFTWARE FOR SOCIAL NETWORKING AND ONLINE DATING (U.S. CLS. 100 AND 101).

CLASS 45—PERSONAL AND LEGAL SERVICES

FOR DATING SERVICES; DATING SERVICES, NAMELY, PROVIDING AN ON-LINE COMPUTER DATABASE FEATURING SINGLE PEOPLE INTERESTED IN MEETING OTHER SINGLE PEOPLE; INTERNET-BASED DATING, SOCIAL INTRODUCTION AND SOCIAL NETWORKING SERVICES; PROVIDING A SOCIAL NETWORKING WEBSITE FOR ENTERTAINMENT PURPOSES (U.S. CLS. 100 AND 101).

MICHELLE DUBOIS, EXAMINING ATTORNEY

NO CLAIM IS MADE TO THE EXCLUSIVE RIGHT TO USE "DESIGN", APART FROM THE MARK AS SHOWN.

THE MARK CONSISTS OF THE TEXT "VX ONE DESIGN" IN STYLIZED FONT.

CLASS 12—VEHICLES

FOR SAILBOATS (U.S. CLS. 19, 21, 23, 31, 35 AND 44).

CLASS 41—EDUCATION AND ENTERTAINMENT

FOR ENTERTAINMENT IN THE NATURE OF BOAT RACES (U.S. CLS. 100, 101 AND 107).

DAVID H. STINE, EXAMINING ATTORNEY

SN 85-291,102. I'M NOT OLD, LLC, CROFTON, MD. FILED 4-9-2011.

I'M NOT OLD!

THE MARK CONSISTS OF STANDARD CHARACTERS WITHOUT CLAIM TO ANY PARTICULAR FONT, STYLE, SIZE, OR COLOR.

CLASS 25—CLOTHING

FOR SHIRTS; T-SHIRTS (U.S. CLS. 22 AND 39).

CLASS 42—SCIENTIFIC AND COMPUTER SERVICES

FOR COMPUTER SERVICES, NAMELY, CREATING AN ON-LINE COMMUNITY FOR REGISTERED USERS TO PARTICIPATE IN DISCUSSIONS, GET FEEDBACK FROM THEIR PEERS, FORM VIRTUAL COMMUNITIES, AND ENGAGE IN SOCIAL NETWORKING FOCUSING AROUND ACTIVITIES AND INTERESTS OF ACTIVE ADULTS (U.S. CLS. 100 AND 101).

DAVID C. REIHNER, EXAMINING ATTORNEY

SN 85-291,120. CAROL ANDERSON LICENSING, LLC,
RANCHO DOMINGUEZ, CA. FILED 4-10-2011.

SN 85-291,326. THE AMERICAN SOCIETY FOR THE PRE-
VENTION OF CRUELTY TO ANIMALS, NEW YORK, NY.
FILED 4-11-2011.

IN CAHOOTS

THE MARK CONSISTS OF STANDARD CHARACTERS
WITHOUT CLAIM TO ANY PARTICULAR FONT, STYLE,
SIZE, OR COLOR.

CLASS 25—CLOTHING

FOR CLOTHING AND CLOTHING ACCESSORIES,
NAMELY, JEANS, PANTS, SHORTS, DRESSES, SKIRTS,
SKORTS, SHIRTS, T-SHIRTS, BLOUSES, SWEATERS,
VESTS, JACKETS, COATS, PONCHOS, FOOTWEAR,
TIES, HATS, SCARVES, BELTS AND GLOVES (U.S.
CLS. 22 AND 39).

CLASS 35—ADVERTISING AND BUSINESS

FOR RETAIL SERVICES BY DIRECT SOLICITATION
BY SALES AGENTS IN THE FIELD OF CLOTHING (U.S.
CLS. 100, 101 AND 102).
MEGHAN REINHART, EXAMINING ATTORNEY

SN 85-291,121. CAROL ANDERSON LICENSING, LLC,
RANCHO DOMINGUEZ, CA. FILED 4-10-2011.

CAHOOTS

THE MARK CONSISTS OF STANDARD CHARACTERS
WITHOUT CLAIM TO ANY PARTICULAR FONT, STYLE,
SIZE, OR COLOR.

CLASS 25—CLOTHING

FOR CLOTHING AND CLOTHING ACCESSORIES,
NAMELY, JEANS, PANTS, SHORTS, DRESSES, SKIRTS,
SKORTS, SHIRTS, T-SHIRTS, BLOUSES, SWEATERS,
VESTS, JACKETS, COATS, PONCHOS, FOOTWEAR,
TIES, HATS, SCARVES, BELTS AND GLOVES (U.S.
CLS. 22 AND 39).

CLASS 35—ADVERTISING AND BUSINESS

FOR RETAIL SERVICES BY DIRECT SOLICITATION
BY SALES AGENTS IN THE FIELD OF CLOTHING (U.S.
CLS. 100, 101 AND 102).
MEGHAN REINHART, EXAMINING ATTORNEY

SAFER

THE MARK CONSISTS OF STANDARD CHARACTERS
WITHOUT CLAIM TO ANY PARTICULAR FONT, STYLE,
SIZE, OR COLOR.

CLASS 16—PAPER GOODS AND PRINTED MATTER

FOR EDUCATIONAL KITS SOLD AS A UNIT IN THE
FIELD OF CANINE AGGRESSION AND BEHAVIOR
ASSESSMENT CONSISTING PRIMARILY OF PRINTED
INSTRUCTIONAL MATERIALS IN THE NATURE OF A
COURSE MANUAL, TRAINING GUIDE, WORKSHEETS
AND INCLUDING A VIDEO DVD (U.S. CLS. 2, 5, 22, 23,
29, 37, 38 AND 50).
FIRST USE 12-1-2000; IN COMMERCE 12-1-2000.

CLASS 41—EDUCATION AND ENTERTAIN- MENT

FOR EDUCATIONAL SERVICES, NAMELY, CON-
DUCTING TRAINING COURSES, WORKSHOPS, SEMI-
NARS AND CLASSES IN THE FIELD OF CANINE
AGGRESSION AND BEHAVIOR ASSESSMENT AND
THE DISTRIBUTION OF TRAINING MATERIALS IN
CONNECTION THEREWITH (U.S. CLS. 100, 101 AND
107).
FIRST USE 12-1-2010; IN COMMERCE 12-1-2010.
DAWN FELDMAN, EXAMINING ATTORNEY

SN 85-291,357. PENTON MEDIA, INC., NEW YORK, NY.
FILED S.R. 4-11-2011; AM. P.R. 5-2-2011.

Future of Wellness

THE MARK CONSISTS OF STANDARD CHARACTERS
WITHOUT CLAIM TO ANY PARTICULAR FONT, STYLE,
SIZE, OR COLOR.

CLASS 16—PAPER GOODS AND PRINTED MATTER

FOR MAGAZINE SECTIONS IN THE FIELD OF
HEALTHY LIVING AND THE NATURAL, ORGANIC
AND HEALTHY-LIFESTYLE PRODUCTS INDUSTRY;
PRINTED MATERIALS, NAMELY, JOURNALS FEAT-
URING NEWS AND INFORMATION IN THE FIELD
OF HEALTHY LIVING AND THE NATURAL, ORGANIC
AND HEALTHY-LIFESTYLE PRODUCTS INDUSTRY;
PRINTED REPORTS FEATURING NEWS AND INFOR-
MATION IN THE FIELD OF HEALTHY LIVING AND
THE NATURAL, ORGANIC AND HEALTHY-LIFE-
STYLE PRODUCTS INDUSTRY (U.S. CLS. 2, 5, 22, 23,
29, 37, 38 AND 50).
FIRST USE 3-9-2011; IN COMMERCE 3-9-2011.

CLASS 41—EDUCATION AND ENTERTAINMENTSN 85-291,373. PENTON MEDIA, INC., NEW YORK, NY.
FILED S.R. 4-11-2011; AM. P.R. 5-2-2011.

FOR EDUCATION SERVICES, NAMELY, PROVIDING LIVE AND ON-LINE CLASSES, SEMINARS, WORKSHOPS, CONFERENCES AND CLASSES IN THE FIELD OF HEALTHY LIVING AND THE NATURAL, ORGANIC AND HEALTHY-LIFESTYLE PRODUCTS INDUSTRY; EDUCATIONAL AND ENTERTAINMENT SERVICES, NAMELY, CONDUCTING LIVE AND ON-LINE CLASSES, SEMINARS, WORKSHOPS, CONFERENCES AND CLASSES IN THE FIELD OF HEALTHY LIVING AND THE NATURAL, ORGANIC AND HEALTHY-LIFESTYLE PRODUCTS INDUSTRY AND DISTRIBUTION OF COURSE MATERIALS IN CONNECTION THEREWITH, AND EDUCATION CONSULTING RELATED THERETO; ENTERTAINMENT SERVICES, NAMELY, PROVIDING WEBCASTS IN THE FIELD OF HEALTHY LIVING AND THE NATURAL, ORGANIC AND HEALTHY-LIFESTYLE PRODUCTS INDUSTRY; ON-LINE JOURNALS, NAMELY, BLOGS FEATURING NEWS AND INFORMATION IN THE FIELD OF HEALTHY LIVING AND THE NATURAL, ORGANIC AND HEALTHY-LIFESTYLE PRODUCTS INDUSTRY; PROVIDING ON-LINE PUBLICATIONS IN THE NATURE OF MAGAZINES, NEWSLETTERS, COLUMNS, REPORTS, AND WHITE PAPERS IN THE FIELD OF HEALTHY LIVING AND THE NATURAL, ORGANIC AND HEALTHY-LIFESTYLE PRODUCTS INDUSTRY (U.S. CLS. 100, 101 AND 107).

FIRST USE 3-9-2011; IN COMMERCE 3-9-2011.
EMILY CARLSEN, EXAMINING ATTORNEY



THE COLOR(S) GREEN AND BLACK IS/ARE CLAIMED AS A FEATURE OF THE MARK.

THE MARK CONSISTS OF THE WORDING "FUTURE OF WELLNESS" DEPICTED IN BLACK. TO THE LEFT OF THE WORDING IS THE DESIGN OF A GREEN FLOWER, OUTLINED IN BLACK.

SN 85-291,363. BOUTON, JAMES, ALFORD, MA. FILED 4-11-2011.

THE PLAYERS' CHOICE

THE MARK CONSISTS OF STANDARD CHARACTERS WITHOUT CLAIM TO ANY PARTICULAR FONT, STYLE, SIZE, OR COLOR.

CLASS 29—MEATS AND PROCESSED FOODS

FOR BEEF JERKY; JERKY; NUT AND SEED-BASED SNACK BARS; NUT-BASED SNACK FOODS; ORGANIC NUT AND SEED-BASED SNACK BARS; PROCESSED EDIBLE SEEDS; PROCESSED FRUIT- AND NUT-BASED FOOD BARS; PROCESSED NUTS; PROCESSED PUMPKIN SEEDS; PROCESSED SUNFLOWER SEEDS; ROASTED NUTS; SEASONED NUTS; SHELLED NUTS; SNACK MIX CONSISTING OF DEHYDRATED FRUIT AND PROCESSED NUTS; SNACK MIX CONSISTING OF PRIMARILY OF PROCESSED NUTS, SEEDS, DRIED FRUIT AND ALSO INCLUDING CHOCOLATE; SNACK MIX CONSISTING PRIMARILY OF DEHYDRATED FRUITS, PROCESSED NUTS AND ALSO INCLUDING SESAME STICKS; SNACK MIX CONSISTING PRIMARILY OF PROCESSED FRUITS, PROCESSED NUTS AND/OR RAISINS; TRAIL MIX CONSISTING PRIMARILY OF PROCESSED NUTS, SEEDS, DRIED FRUIT AND ALSO INCLUDING CHOCOLATE (U.S. CL. 46).

CLASS 30—STAPLE FOODS

FOR CHEESE FLAVORED PUFFED CORN SNACKS; CHEESE-FLAVORED CORN SNACKS; PUFFED CORN SNACKS (U.S. CL. 46).
WON TEAK OH, EXAMINING ATTORNEY

CLASS 16—PAPER GOODS AND PRINTED MATTER

FOR MAGAZINE SECTIONS IN THE FIELD OF HEALTHY LIVING AND THE NATURAL, ORGANIC AND HEALTHY-LIFESTYLE PRODUCTS INDUSTRY; PRINTED MATERIALS, NAMELY, JOURNALS FEATURING NEWS AND INFORMATION IN THE FIELD OF HEALTHY LIVING AND THE NATURAL, ORGANIC AND HEALTHY-LIFESTYLE PRODUCTS INDUSTRY; PRINTED REPORTS FEATURING NEWS AND INFORMATION IN THE FIELD OF HEALTHY LIVING AND THE NATURAL, ORGANIC AND HEALTHY-LIFESTYLE PRODUCTS INDUSTRY (U.S. CLS. 2, 5, 22, 23, 29, 37, 38 AND 50).

FIRST USE 3-9-2011; IN COMMERCE 3-9-2011.

CLASS 41—EDUCATION AND ENTERTAINMENT

FOR EDUCATION SERVICES, NAMELY, PROVIDING LIVE AND ON-LINE CLASSES, SEMINARS, WORKSHOPS, CONFERENCES AND CLASSES IN THE FIELD OF HEALTHY LIVING AND THE NATURAL, ORGANIC AND HEALTHY-LIFESTYLE PRODUCTS INDUSTRY; EDUCATIONAL AND ENTERTAINMENT SERVICES, NAMELY, CONDUCTING LIVE AND ON-LINE CLASSES, SEMINARS, WORKSHOPS, CONFERENCES AND CLASSES IN THE FIELD OF HEALTHY LIVING AND THE NATURAL, ORGANIC AND HEALTHY-LIFESTYLE PRODUCTS INDUSTRY AND DISTRIBUTION OF COURSE MATERIALS IN CONNECTION THEREWITH, AND EDUCATION CONSULTING RELATED THERETO; ENTERTAINMENT SERVICES, NAMELY, PROVIDING WEBCASTS IN THE FIELD OF HEALTHY LIVING AND THE NATURAL, ORGANIC AND HEALTHY-LIFESTYLE PRODUCTS INDUSTRY; ON-LINE JOURNALS, NAMELY, BLOGS FEATURING NEWS AND INFORMATION IN THE FIELD OF HEALTHY LIVING AND THE NATURAL, ORGANIC AND HEALTHY-LIFESTYLE PRODUCTS INDUSTRY; PROVIDING ON-LINE PUBLICATIONS IN THE NATURE OF MAGAZINES, NEWSLETTERS, COLUMNS, REPORTS, AND WHITE PAPERS IN THE FIELD OF HEALTHY LIVING AND THE NATURAL, ORGANIC AND HEALTHY-LIFESTYLE PRODUCTS INDUSTRY (U.S. CLS. 100, 101 AND 107).

FIRST USE 3-9-2011; IN COMMERCE 3-9-2011.
EMILY CARLSEN, EXAMINING ATTORNEY

SN 85-291,403. RADAR GROUP, LLC, SCOTTSDALE, AZ. FILED 4-11-2011.

SN 85-291,450. GOLDEN OMEGA S.A., SANTIAGO, CHILE, FILED 4-11-2011.

EARTH NO MORE

THE MARK CONSISTS OF STANDARD CHARACTERS WITHOUT CLAIM TO ANY PARTICULAR FONT, STYLE, SIZE, OR COLOR.

CLASS 9—ELECTRICAL AND SCIENTIFIC APPARATUS

FOR COMPUTER GAME CARTRIDGES; COMPUTER GAME DISCS; COMPUTER GAME SOFTWARE; COMPUTER VIDEO GAME CARTRIDGES; COMPUTER VIDEO GAME DISCS; COMPUTER VIDEO GAME SOFTWARE; INTERACTIVE MULTIMEDIA COMPUTER GAME PROGRAMS AND COMPUTER VIDEO GAME SOFTWARE THAT IS DOWNLOADABLE VIA THE INTERNET (U.S. CLS. 21, 23, 26, 36 AND 38).

CLASS 41—EDUCATION AND ENTERTAINMENT

FOR ENTERTAINMENT SERVICES IN THE NATURE OF COMPUTER GAMES AND COMPUTER VIDEO GAMES PROVIDED AND PLAYED THROUGH A GLOBAL COMPUTER NETWORK (U.S. CLS. 100, 101 AND 107).

ANNE FARRELL, EXAMINING ATTORNEY

SN 85-291,419. BAG BAZAAR, LTD, NEW YORK, NY. FILED 4-11-2011.

Adam & Alix

THE MARK CONSISTS OF STANDARD CHARACTERS WITHOUT CLAIM TO ANY PARTICULAR FONT, STYLE, SIZE, OR COLOR.

CLASS 18—LEATHER GOODS

FOR BACKPACKS; DUFFEL BAGS; HANDBAGS; POCKETBOOKS; PURSES; SHOULDER BAGS; TOTE BAGS (U.S. CLS. 1, 2, 3, 22 AND 41).

FIRST USE 10-1-2009; IN COMMERCE 10-1-2009.

CLASS 25—CLOTHING

FOR HOSE (U.S. CLS. 22 AND 39). FIRST USE 10-1-2009; IN COMMERCE 10-1-2009. FRANK LATTUCA, EXAMINING ATTORNEY

PROGOLDEN

THE MARK CONSISTS OF STANDARD CHARACTERS WITHOUT CLAIM TO ANY PARTICULAR FONT, STYLE, SIZE, OR COLOR.

CLASS 5—PHARMACEUTICALS

FOR FOOD FOR MEDICAL PURPOSES THAT HELP IN THE MEDICAL TREATMENT OF CANCER, NAMELY, FISH AND FISH BY-PRODUCTS IN THE NATURE OF FISH OIL; EDIBLE FISH OIL FOR MEDICAL PURPOSES, AND FISH OIL FOR PHARMACEUTICAL PURPOSES BEING CANCER; NUTRITIONAL SUPPLEMENTS; NUTRITIONAL ADDITIVES FOR MEDICAL PURPOSES FOR USE IN FOODS AND DIETARY SUPPLEMENTS FOR HUMAN CONSUMPTION (U.S. CLS. 6, 18, 44, 46, 51 AND 52).

CLASS 29—MEATS AND PROCESSED FOODS

FOR FISH OIL NOT FOR MEDICINAL PURPOSES FOR HUMAN CONSUMPTION; FOOD ADDITIVES, NAMELY, NATURAL FOOD EXTRACTS DERIVED FROM FISH, FISH OIL, OR FISH PROTEIN NOT FOR MEDICINAL PURPOSES AND FOR HUMAN CONSUMPTION (U.S. CL. 46).

WILLIAM ROSSMAN, EXAMINING ATTORNEY

SN 85-291,466. CAESARS LICENSE COMPANY, LLC, LAS VEGAS, NV. FILED 4-11-2011.



THE MARK CONSISTS OF THE WORDS "THE LINQ" IN STYLIZED LETTERS.

CLASS 36—INSURANCE AND FINANCIAL

FOR SHOPPING MALL SERVICES, NAMELY, LEASING SHOPPING MALL SPACE AND CONDUCTING REAL ESTATE MANAGEMENT OF SHOPPING MALLS (U.S. CLS. 100, 101 AND 102).

CLASS 43—HOTEL AND RESTAURANT SERVICES

FOR HOTEL, BAR AND RESTAURANT SERVICES (U.S. CLS. 100 AND 101). AMY KERTGATE, EXAMINING ATTORNEY

SN 85-291,516. THE INNOVATION GAMES COMPANY, MOUNTAIN VIEW, CA. FILED 4-11-2011.

SN 85-291,522. BOARDWALK AG, LLC, PLANO, TX. FILED 4-11-2011.

PERFORMANCE. IT'S WHAT WE
DO.

KNOWSY KNOWS

THE MARK CONSISTS OF STANDARD CHARACTERS WITHOUT CLAIM TO ANY PARTICULAR FONT, STYLE, SIZE, OR COLOR.

CLASS 9—ELECTRICAL AND SCIENTIFIC APPARATUS

FOR COMPUTER SOFTWARE AND DOWNLOADABLE COMPUTER SOFTWARE FOR PLAYING GAMES, DISPLAYING ADVERTISEMENTS, PERFORMING MARKET RESEARCH, AND PROVIDING AND OBTAINING INFORMATION ABOUT THE TRAITS AND INTERESTS OF CELEBRITIES, FRIENDS, COMMUNITIES, AND LOCAL POPULATIONS; COMPUTER SOFTWARE AND DOWNLOADABLE COMPUTER SOFTWARE FOR USE ON MOBILE DEVICES FOR PLAYING GAMES, DISPLAYING ADVERTISEMENTS, PERFORMING MARKET RESEARCH, AND PROVIDING AND OBTAINING INFORMATION ABOUT THE TRAITS AND INTERESTS OF CELEBRITIES, FRIENDS, COMMUNITIES, AND LOCAL POPULATIONS (U.S. CLS. 21, 23, 26, 36 AND 38).

CLASS 35—ADVERTISING AND BUSINESS

FOR ADVERTISING SERVICES; MARKETING CONSULTING; MARKETING RESEARCH SERVICES (U.S. CLS. 100, 101 AND 102).

CLASS 41—EDUCATION AND ENTERTAINMENT

FOR ENTERTAINMENT SERVICES, NAMELY, PROVIDING TEMPORARY USE OF NON-DOWNLOADABLE COMPUTER GAMES; ENTERTAINMENT SERVICES, NAMELY, PROVIDING TEMPORARY USE OF NON-DOWNLOADABLE COMPUTER GAMES FOR USE ON MOBILE DEVICES; ARRANGING CONTESTS (U.S. CLS. 100, 101 AND 107).

CLASS 42—SCIENTIFIC AND COMPUTER SERVICES

FOR PROVIDING ON-LINE NON-DOWNLOADABLE SOFTWARE FOR DISPLAYING ADVERTISEMENTS, PERFORMING MARKET RESEARCH, AND PROVIDING AND OBTAINING INFORMATION ABOUT THE TRAITS AND INTERESTS OF CELEBRITIES, FRIENDS, COMMUNITIES, AND LOCAL POPULATIONS; PROVIDING ON-LINE NON-DOWNLOADABLE SOFTWARE FOR USE ON MOBILE DEVICES FOR DISPLAYING ADVERTISEMENTS, PERFORMING MARKET RESEARCH, AND PROVIDING AND OBTAINING INFORMATION ABOUT THE TRAITS AND INTERESTS OF CELEBRITIES, FRIENDS, COMMUNITIES, AND LOCAL POPULATIONS; DESIGN AND DEVELOPMENT OF COMPUTER SOFTWARE; APPLICATION SERVICE PROVIDER FEATURING SOFTWARE FOR USE IN PLAYING GAMES, DISPLAYING ADVERTISEMENTS, PERFORMING MARKET RESEARCH, AND PROVIDING AND OBTAINING INFORMATION ABOUT THE TRAITS AND INTERESTS OF CELEBRITIES, FRIENDS, COMMUNITIES, AND LOCAL POPULATIONS (U.S. CLS. 100 AND 101).

JULIE GUTTAURO, EXAMINING ATTORNEY

THE MARK CONSISTS OF STANDARD CHARACTERS WITHOUT CLAIM TO ANY PARTICULAR FONT, STYLE, SIZE, OR COLOR.

CLASS 35—ADVERTISING AND BUSINESS

FOR AUTOMOBILE DEALERSHIP (U.S. CLS. 100, 101 AND 102).
FIRST USE 8-1-2010; IN COMMERCE 8-1-2010.

CLASS 37—CONSTRUCTION AND REPAIR

FOR AUTOMOBILE REPAIR AND MAINTENANCE (U.S. CLS. 100, 103 AND 106).
FIRST USE 8-1-2010; IN COMMERCE 8-1-2010.
AMY KERTGATE, EXAMINING ATTORNEY

SN 85-291,567. DAVISON DESIGN AND DEVELOPMENT, INC., PITTSBURGH, PA. FILED 4-11-2011.

Dare to Invent

THE MARK CONSISTS OF STANDARD CHARACTERS WITHOUT CLAIM TO ANY PARTICULAR FONT, STYLE, SIZE, OR COLOR.

CLASS 35—ADVERTISING AND BUSINESS

FOR BUSINESS CONSULTATION AND MANAGEMENT REGARDING MARKETING ACTIVITIES AND LAUNCHING OF NEW PRODUCTS AND PACKAGING; BRAND CONCEPT AND IDEAS AND BRAND DEVELOPMENT SERVICES FOR CORPORATE AND INDIVIDUAL CLIENTS (U.S. CLS. 100, 101 AND 102).
FIRST USE 4-7-2011; IN COMMERCE 4-7-2011.

CLASS 42—SCIENTIFIC AND COMPUTER SERVICES

FOR INNOVATION CONSULTING SERVICES, NAMELY, ADVISING OTHERS IN THE AREA OF PRODUCT AND PACKAGING DEVELOPMENT; PRODUCT AND PACKAGING RESEARCH AND DEVELOPMENT; DESIGN AND TESTING OF NEW PRODUCTS AND PACKAGING FOR OTHERS (U.S. CLS. 100 AND 101).
FIRST USE 4-7-2011; IN COMMERCE 4-7-2011.

CLASS 45—PERSONAL AND LEGAL SERVICES

FOR LICENSING OF INTELLECTUAL PROPERTY; LICENSING SERVICES, NAMELY, INTELLECTUAL PROPERTY CONSULTING SERVICES IN THE FIELD OF INVENTION (U.S. CLS. 100 AND 101).
FIRST USE 4-7-2011; IN COMMERCE 4-7-2011.
JUSTINE D. PARKER, EXAMINING ATTORNEY

SN 85-291,613. NO GLUTEN NATURAL GIRL PRODUCTS LLC, NEW LENOX, IL. FILED 4-11-2011.



THE MARK CONSISTS OF THE STYLIZED TEXT "NG".

CLASS 3—COSMETICS AND CLEANING PREPARATIONS

FOR BIOTECHNOLOGICAL CHEMICAL AND SPRAY CLEANERS FOR INDUSTRIAL AND HOUSEHOLD APPLICATIONS SUCH AS STAIN REMOVAL, ODOR ELIMINATION, AND BIO REMEDIATION OF MANY TYPES OF ORGANIC AND HYDROCARBON-BASED MATERIALS; BLUSH; BODY POWDER; EYE SHADOWS; EYELINER; FABRIC SOFTENERS FOR LAUNDRY USE; FACE POWDER; FACIAL CONCEALER; FOUNDATION MAKE-UP; LAUNDRY SOAP; LIP BALM; LIP GLOSS; LIP LINER; LIQUID SOAP; MAKE-UP POWDER; MOUSSE FOR SKIN FACIAL; PERFUMED POWDER; STAIN REMOVERS (U.S. CLS. 1, 4, 6, 50, 51 AND 52).

FIRST USE 12-31-2010; IN COMMERCE 3-11-2011.

CLASS 35—ADVERTISING AND BUSINESS

FOR ON-LINE RETAIL STORE SERVICES FEATURING MAKE-UP, BODY CARE PRODUCTS, HYGIENE PRODUCTS, AND HOUSEHOLD CLEANING PRODUCTS (U.S. CLS. 100, 101 AND 102).

FIRST USE 12-31-2010; IN COMMERCE 3-11-2011.
ANDREW LEASER, EXAMINING ATTORNEY

SN 85-291,627. RUIS, ANITA, TUJUNGA, CA. AND FIELDS, AMANDA, TUJUNGA, CA. AND SHEAD, KIMBERLY, TUJUNGA, CA. FILED 4-11-2011.

The Deliquesce Company

THE MARK CONSISTS OF STANDARD CHARACTERS WITHOUT CLAIM TO ANY PARTICULAR FONT, STYLE, SIZE, OR COLOR.

NO CLAIM IS MADE TO THE EXCLUSIVE RIGHT TO USE "COMPANY", APART FROM THE MARK AS SHOWN.

CLASS 35—ADVERTISING AND BUSINESS

FOR RETAIL BAKERY SHOPS; RETAIL STORE SERVICES FEATURING CAKES, COOKIES, PIES, FINGER SANDWICHES, SCONES, BISCUITS, MUFFINS, MINI POT PIES, TEA AND COFFEE COZIES, FILTERS, PRESSES, POTS, TEA BALLS AND BAGS, METAL SCULPTURE, PAINTINGS, WOOD WORK CRAFTS (U.S. CLS. 100, 101 AND 102).

CLASS 43—HOTEL AND RESTAURANT SERVICES

FOR RESTAURANT AND CAFE SERVICES (U.S. CLS. 100 AND 101).

ANDREW LEASER, EXAMINING ATTORNEY

SN 85-291,647. KOLOS, EDWARD, STUART, FL. FILED 4-11-2011.

Hydrozyme

THE MARK CONSISTS OF STANDARD CHARACTERS WITHOUT CLAIM TO ANY PARTICULAR FONT, STYLE, SIZE, OR COLOR.

CLASS 1—CHEMICALS

FOR PROBIOTIC COMPOSITIONS FOR USE AS INGREDIENTS FOR FOOD AND BEVERAGES, NAMELY, PROBIOTIC BACTERIA AND PROBIOTIC BACTERIAL CULTURES (U.S. CLS. 1, 5, 6, 10, 26 AND 46).

CLASS 3—COSMETICS AND CLEANING PREPARATIONS

FOR COSMETIC CREAMS FOR SKIN CARE; NON-MEDICATED SKIN CARE PREPARATIONS, NAMELY, CREAMS, LOTIONS, GELS, TONERS, CLEANERS AND PEELS (U.S. CLS. 1, 4, 6, 50, 51 AND 52).

EDWARD NELSON, EXAMINING ATTORNEY

SN 85-291,667. ELIZABETH HLAWSA, PEMBROKE PINES, FL. FILED 4-11-2011.

Put A Cuban In Your Mouth

THE MARK CONSISTS OF STANDARD CHARACTERS WITHOUT CLAIM TO ANY PARTICULAR FONT, STYLE, SIZE, OR COLOR.

CLASS 16—PAPER GOODS AND PRINTED MATTER

FOR CALENDARS (U.S. CLS. 2, 5, 22, 23, 29, 37, 38 AND 50).

CLASS 21—HOUSEWARES AND GLASS

FOR SHOT GLASSES (U.S. CLS. 2, 13, 23, 29, 30, 33, 40 AND 50).

CLASS 25—CLOTHING

FOR HATS; SHIRTS; T-SHIRTS; TEE SHIRTS (U.S. CLS. 22 AND 39).

CLASS 34—SMOKERS' ARTICLES

FOR HUMIDORS (U.S. CLS. 2, 8, 9 AND 17).

REBECCA EISINGER, EXAMINING ATTORNEY

SN 85-291,694. DELKA LTD., MALVERN, PA. FILED 4-11-2011.

KLCK

THE MARK CONSISTS OF STANDARD CHARACTERS WITHOUT CLAIM TO ANY PARTICULAR FONT, STYLE, SIZE, OR COLOR.

CLASS 3—COSMETICS AND CLEANING PREPARATIONS

FOR PERFUME; PERFUMES (U.S. CLS. 1, 4, 6, 50, 51 AND 52).

CLASS 14—JEWELRY

FOR JEWELRY (U.S. CLS. 2, 27, 28 AND 50).

CLASS 18—LEATHER GOODS

FOR HANDBAGS (U.S. CLS. 1, 2, 3, 22 AND 41).

CLASS 25—CLOTHING

FOR BRAS; CAMISOLES; HOSIERY; LEGGINGS; PANTIES; SHOES; TANK TOPS (U.S. CLS. 22 AND 39).
GRETCHEN ULRICH, EXAMINING ATTORNEY

SN 85-291,710. GARDEN ART INNOVATIONS, LLC, AKRON, OH. FILED 4-11-2011.

MIXY-MIXY

THE MARK CONSISTS OF STANDARD CHARACTERS WITHOUT CLAIM TO ANY PARTICULAR FONT, STYLE, SIZE, OR COLOR.

CLASS 3—COSMETICS AND CLEANING PREPARATIONS

FOR CUSTOM BLENDED COSMETICS (U.S. CLS. 1, 4, 6, 50, 51 AND 52).

CLASS 35—ADVERTISING AND BUSINESS

FOR RETAIL STORE AND ON-LINE RETAIL STORE SERVICES FEATURING CUSTOM BLENDED COSMETICS; RETAIL STORE SERVICES FEATURING CUSTOM BLENDED COSMETICS ACCESSIBLE ON-LINE AND BY TELEPHONE, FACSIMILE AND MAIL ORDER (U.S. CLS. 100, 101 AND 102).

CLASS 40—MATERIAL TREATMENT

FOR CUSTOM COSMETICS BLENDING SERVICES (U.S. CLS. 100, 103 AND 106).

CLASS 44—MEDICAL, BEAUTY AND AGRICULTURAL SERVICES

FOR COLOR ANALYSIS FOR COSMETIC PURPOSES; CONSULTATION SERVICES IN THE FIELD OF COSMETICS AND MAKEUP, NAMELY, IN-PERSON COSMETIC AND MAKEUP CONSULTATION AND ON-LINE MAKEUP CONSULTATION SERVICES AND APPLICATION SERVICES (U.S. CLS. 100 AND 101).
SUSAN LESLIE DUBOIS, EXAMINING ATTORNEY

SN 85-291,835. SHEDRAIN CORPORATION, PORTLAND, OR. FILED 4-11-2011.

BE SEEN FROM EVERY ANGLE

THE MARK CONSISTS OF STANDARD CHARACTERS WITHOUT CLAIM TO ANY PARTICULAR FONT, STYLE, SIZE, OR COLOR.

CLASS 18—LEATHER GOODS

FOR UMBRELLAS (U.S. CLS. 1, 2, 3, 22 AND 41).
FIRST USE 1-0-2010; IN COMMERCE 1-0-2010.

CLASS 25—CLOTHING

FOR RAIN WEAR (U.S. CLS. 22 AND 39).
FIRST USE 1-0-2010; IN COMMERCE 1-0-2010.
DOUGLAS LEE, EXAMINING ATTORNEY

SN 85-291,845. COUNSEL FINANCIAL II LLC, AKA COUNSEL FINANCIAL SERVICES, WILLIAMSVILLE, NY. FILED 4-11-2011.

MASS TORT FINANCING MADE
PERFECT

THE MARK CONSISTS OF STANDARD CHARACTERS WITHOUT CLAIM TO ANY PARTICULAR FONT, STYLE, SIZE, OR COLOR.

NO CLAIM IS MADE TO THE EXCLUSIVE RIGHT TO USE "MASS TORT FINANCING", APART FROM THE MARK AS SHOWN.

CLASS 35—ADVERTISING AND BUSINESS

FOR BUSINESS ADVICE AND INFORMATION RELATING TO LOANS, FINANCE AND CAPITAL (U.S. CLS. 100, 101 AND 102).
FIRST USE 4-1-2011; IN COMMERCE 4-1-2011.

CLASS 36—INSURANCE AND FINANCIAL

FOR ACCOUNTS RECEIVABLES FINANCING; FINANCING AND LOAN SERVICES; PROVIDING WORKING CAPITAL (U.S. CLS. 100, 101 AND 102).
FIRST USE 4-1-2011; IN COMMERCE 4-1-2011.
KATHRYN COWARD, EXAMINING ATTORNEY

SN 85-291,955. FRC BALANCE LLC, SCOTTSDALE, AZ. FILED 4-11-2011.

SN 85-292,332. RANDOM LOVE, VALLEJO, CA. FILED 4-11-2011.

TRUE FOOD KITCHEN

THE MARK CONSISTS OF STANDARD CHARACTERS WITHOUT CLAIM TO ANY PARTICULAR FONT, STYLE, SIZE, OR COLOR.

OWNER OF U.S. REG. NOS. 3,620,741, 3,688,743 AND 3,961,181.

NO CLAIM IS MADE TO THE EXCLUSIVE RIGHT TO USE "FOOD KITCHEN", APART FROM THE MARK AS SHOWN.

CLASS 35—ADVERTISING AND BUSINESS

FOR HOSTING OF BUSINESS EVENTS AND MEETINGS FOR OTHERS; PROVIDING A VENUE FOR BUSINESS EVENTS AND MEETINGS (U.S. CLS. 100, 101 AND 102).

FIRST USE 8-2-2010; IN COMMERCE 8-2-2010.

CLASS 41—EDUCATION AND ENTERTAINMENT

FOR HOSTING OF SOCIAL ENTERTAINMENT EVENTS; HOSTING BIRTHDAY PARTIES; PROVIDING A VENUE FOR EDUCATIONAL EVENTS; ENTERTAINMENT SERVICES, NAMELY, WINE TASTINGS AND FOOD TASTINGS; HOSTING OF EDUCATIONAL COOKING DEMONSTRATIONS AND LECTURES (U.S. CLS. 100, 101 AND 107).

FIRST USE 8-2-2010; IN COMMERCE 8-2-2010.

KATHERINE CHANG, EXAMINING ATTORNEY

SN 85-292,014. RUM RUNNER PRESS, INC., ROUND ROCK, TX. FILED 4-11-2011.

GOT RUM?

THE MARK CONSISTS OF STANDARD CHARACTERS WITHOUT CLAIM TO ANY PARTICULAR FONT, STYLE, SIZE, OR COLOR.

NO CLAIM IS MADE TO THE EXCLUSIVE RIGHT TO USE "RUM," FOR CLASS 016 ONLY, APART FROM THE MARK AS SHOWN.

CLASS 16—PAPER GOODS AND PRINTED MATTER

FOR MAGAZINES AND NEWSPAPERS FEATURING NEWS ABOUT RUM, RUM-RELATED EVENTS, REVIEWS AND ARTICLES (U.S. CLS. 2, 5, 22, 23, 29, 37, 38 AND 50).

FIRST USE 1-1-2001; IN COMMERCE 5-1-2001.

CLASS 25—CLOTHING

FOR CLOTHING, NAMELY, TOPS, BOTTOMS, SHIRTS, HATS, APRONS, TIES (U.S. CLS. 22 AND 39).

FIRST USE 1-1-2001; IN COMMERCE 5-1-2001.

TOBY BULLOFF, EXAMINING ATTORNEY

RANDOM LOVE

THE MARK CONSISTS OF STANDARD CHARACTERS WITHOUT CLAIM TO ANY PARTICULAR FONT, STYLE, SIZE, OR COLOR.

CLASS 9—ELECTRICAL AND SCIENTIFIC APPARATUS

FOR AUDIO RECORDINGS FEATURING MUSIC AND LYRICS; COMPACT DISCS FEATURING MUSIC; DIGITAL MUSIC DOWNLOADABLE FROM THE INTERNET; SOUND RECORDINGS FEATURING MUSIC AND LYRICS (U.S. CLS. 21, 23, 26, 36 AND 38).

FIRST USE 3-14-2010; IN COMMERCE 3-14-2010.

CLASS 41—EDUCATION AND ENTERTAINMENT

FOR ENTERTAINMENT, NAMELY, LIVE MUSIC CONCERTS (U.S. CLS. 100, 101 AND 107).

FIRST USE 3-14-2010; IN COMMERCE 3-14-2010.

SEAN CROWLEY, EXAMINING ATTORNEY

SN 85-292,731. OP TECHNOLOGY, LLC, NYACK, NY. FILED 4-12-2011.

PEERSONAS

THE MARK CONSISTS OF STANDARD CHARACTERS WITHOUT CLAIM TO ANY PARTICULAR FONT, STYLE, SIZE, OR COLOR.

CLASS 35—ADVERTISING AND BUSINESS

FOR ON-LINE BUSINESS NETWORKING SERVICES (U.S. CLS. 100, 101 AND 102).

CLASS 45—PERSONAL AND LEGAL SERVICES

FOR INTERNET BASED SOCIAL NETWORKING, INTRODUCTION, AND DATING SERVICES (U.S. CLS. 100 AND 101).

BARBARA A. GOLD, EXAMINING ATTORNEY

SN 85-292,759, SUBCULTURE FINANCIAL LLC, AKA EVOSPEND, NEW YORK, NY. FILED 4-12-2011.

C.R.E.A.M.

THE MARK CONSISTS OF STANDARD CHARACTERS WITHOUT CLAIM TO ANY PARTICULAR FONT, STYLE, SIZE, OR COLOR.

CLASS 9—ELECTRICAL AND SCIENTIFIC APPARATUS

FOR COMPUTER SOFTWARE, NAMELY, ELECTRONIC FINANCIAL PLATFORM THAT ACCOMMODATES MULTIPLE TYPES OF PAYMENT AND DEBT TRANSACTIONS IN AN INTEGRATED MOBILE PHONE, PDA, AND WEB BASED ENVIRONMENT (U.S. CLS. 21, 23, 26, 36 AND 38).

CLASS 35—ADVERTISING AND BUSINESS

FOR PROVIDING INCENTIVE AWARD PROGRAMS FOR CUSTOMERS AND EMPLOYEES THROUGH THE DISTRIBUTION OF PREPAID STORED VALUE CARDS FOR THE PURPOSE OF PROMOTING AND REWARDING LOYALTY (U.S. CLS. 100, 101 AND 102).

CLASS 36—INSURANCE AND FINANCIAL

FOR FINANCIAL SERVICES, NAMELY, FUNDING ONLINE CASH ACCOUNTS FROM PREPAID CASH CARDS, BANK ACCOUNTS AND CREDIT CARD ACCOUNTS; ISSUING PREPAID DEBIT CARDS; STORED VALUE PREPAID CARD SERVICES, NAMELY, PROCESSING ELECTRONIC PAYMENTS MADE THROUGH PREPAID CARDS (U.S. CLS. 100, 101 AND 102).
DAVID ELTON, EXAMINING ATTORNEY

SN 85-292,831, HOME HEALTH CO., LLC, SALEM, OR. FILED 4-12-2011.

HERE AT HOME

THE MARK CONSISTS OF STANDARD CHARACTERS WITHOUT CLAIM TO ANY PARTICULAR FONT, STYLE, SIZE, OR COLOR.

CLASS 44—MEDICAL, BEAUTY AND AGRICULTURAL SERVICES

FOR HOME HEALTH CARE SERVICES; NURSING SERVICES; HOME NURSING AID SERVICES; DIETARY AND NUTRITIONAL GUIDANCE; HEALTH CARE; MEDICAL COUNSELING; MEDICAL EVALUATION SERVICES, NAMELY, FUNCTIONAL ASSESSMENT PROGRAM FOR PATIENTS RECEIVING MEDICAL REHABILITATION SERVICES FOR PURPOSES OF GUIDING TREATMENT AND ASSESSING PROGRAM EFFECTIVENESS; NURSING CARE; NUTRITION COUNSELING; OCCUPATIONAL THERAPY SERVICES; PHYSICAL REHABILITATION; PHYSICAL THERAPY; PREPARATION AND DISPENSING OF MEDICATIONS; SPEECH AND HEARING THERAPY; PROVIDING HEALTH INFORMATION; MEDICAL SERVICES AND PROVIDING MEDICAL INFORMATION; HEALTH CARE SERVICES, NAMELY, WELLNESS PROGRAMS; COUNSELING SERVICES IN THE FIELDS OF HEALTH, NUTRITION AND LIFESTYLE WELLNESS; REMOTE MONITORING OF DATA INDICATIVE OF THE HEALTH OR CONDITION OF AN INDIVIDUAL OR GROUP OF INDIVIDUALS (U.S. CLS. 100 AND 101).

CLASS 45—PERSONAL AND LEGAL SERVICES

FOR PERSONAL CARE ASSISTANCE OF ACTIVITIES OF DAILY LIVING, SUCH AS BATHING, GROOMING AND PERSONAL MOBILITY FOR MENTALLY OR PHYSICALLY CHALLENGED PEOPLE; IN-HOME SUPPORT SERVICES TO SENIOR PERSONS, NAMELY, GERIATRIC CARE MANAGEMENT SERVICES IN THE NATURE OF THE COORDINATION OF NECESSARY SERVICES AND PERSONAL CARE FOR OLDER INDIVIDUALS; PERSONAL SHOPPING FOR OTHERS; RUNNING ERRANDS FOR OTHERS; GRIEF COUNSELING; CASE MANAGEMENT SERVICES, NAMELY, COORDINATION OF LEGAL, SOCIAL AND PSYCHOLOGICAL SERVICES FOR ELDERLY PERSONS (U.S. CLS. 100 AND 101).

GIANCARLO CASTRO, EXAMINING ATTORNEY

SN 85-292,926, BARBARA MCVICKER, LLC, WORTHINGTON, OH. FILED 4-12-2011.



THE MARK CONSISTS OF AN IMAGE OF THREE PERSONS, THE PERSON ON THE LEFT-HAND SIDE IS A CHILD WITH A BALL, THE PERSON IN THE MIDDLE IS AN ADULT, AND THE PERSON ON THE RIGHT-HAND SIDE IS AN ELDERLY PERSON WITH A CANE; THE ADULT PERSON IN THE MIDDLE HAS HIS OR HER ARMS OUTSTRETCHED OVER THE OTHER TWO PERSONS; BEHIND ALL THREE PERSONS IS A SEMI-CIRCLE DESIGN RESEMBLING A SUNSET WITH SUN-RAYS EMANATING FROM ITS CENTER.

CLASS 9—ELECTRICAL AND SCIENTIFIC APPARATUS

FOR DVDS, CDS, DOWNLOADABLE MP3 FILES, DOWNLOADABLE MP3 RECORDINGS, DOWNLOADABLE WEBINARS, AND DOWNLOADABLE PODCASTS, ALL IN THE FIELD OF ELDER CARE (U.S. CLS. 21, 23, 26, 36 AND 38).

FIRST USE 2-10-2009; IN COMMERCE 2-10-2009.

CLASS 16—PAPER GOODS AND PRINTED MATTER

FOR PRINTED MATERIALS, NAMELY, BOOKS, WORKBOOKS, NOTEPADS, JOURNALS, AND CALENDARS, ALL FEATURING ELDER CARE TOPICS (U.S. CLS. 2, 5, 22, 23, 29, 37, 38 AND 50).

FIRST USE 2-0-2008; IN COMMERCE 2-0-2008.

CLASS 41—EDUCATION AND ENTERTAINMENT

FOR CONDUCTING WORKSHOPS, SEMINARS, CLASSES, AND PRESENTATIONS IN THE FIELDS OF ELDER CARE; NON-FICTION TELEVISION PROGRAMMING IN THE FIELD OF ELDER CARE; THE PROVISION OF ON-LINE PUBLICATIONS IN THE NATURE OF E-BOOKS IN THE FIELD OF ELDER CARE (U.S. CLS. 100, 101 AND 107).

FIRST USE 9-9-2008; IN COMMERCE 9-9-2008.

CLASS 43—HOTEL AND RESTAURANT SERVICES

FOR PROVISION OF INTERNET WEBSITES FEATURING INFORMATION ABOUT ELDER CARE (U.S. CLS. 100 AND 101).

FIRST USE 9-9-2008; IN COMMERCE 9-9-2008.

JANICE L. MCMORROW, EXAMINING ATTORNEY

SN 85-292,937. BEHR PROCESS CORPORATION, SANTA ANA, CA. FILED 4-12-2011.



OWNER OF U.S. REG. NOS. 942,246, 1,551,547 AND OTHERS.

THE MARK CONSISTS OF THE WORD "BEHRPRO" OVER A SOLID RECTANGULAR BLOCK WITH A BEAR IN THE RIGHT CORNER OF THE RECTANGULAR BLOCK.

CLASS 37—CONSTRUCTION AND REPAIR

FOR PAINTING CONTRACTOR SERVICES (U.S. CLS. 100, 103 AND 106).

CLASS 39—TRANSPORTATION AND STORAGE

FOR DISTRIBUTION OF SERVICES, NAMELY, DELIVERY OF PAINT (U.S. CLS. 100 AND 105).

MARTHA FROMM, EXAMINING ATTORNEY

SN 85-292,973. CHARRON, ETHAN ARNOLD, DES MOINES, IA. FILED 4-12-2011.

OCCASICONS

THE MARK CONSISTS OF STANDARD CHARACTERS WITHOUT CLAIM TO ANY PARTICULAR FONT, STYLE, SIZE, OR COLOR.

CLASS 16—PAPER GOODS AND PRINTED MATTER

FOR BUSINESS CARDS; CALENDARS; DECALS; GREETING CARDS; NOTE PADS; NOTEBOOKS; POSTERS; STATIONERY; STICKERS; WRAPPING PAPER (U.S. CLS. 2, 5, 22, 23, 29, 37, 38 AND 50).

FIRST USE 3-17-2011; IN COMMERCE 4-3-2011.

CLASS 26—FANCY GOODS

FOR NOVELTY BUTTONS; ORNAMENTAL NOVELTY BADGES; ORNAMENTAL NOVELTY PINS (U.S. CLS. 37, 39, 40, 42 AND 50).

FIRST USE 3-17-2011; IN COMMERCE 4-3-2011.

JESSICA A. POWERS, EXAMINING ATTORNEY

SN 85-292,977. BEHR PROCESS CORPORATION, SANTA ANA, CA. FILED 4-12-2011.



OWNER OF U.S. REG. NOS. 942,246, 1,551,547 AND OTHERS.

THE COLOR(S) GREY, WHITE AND ORANGE IS/ARE CLAIMED AS A FEATURE OF THE MARK.

THE MARK CONSISTS OF A GREY RECTANGULAR BLOCK WITH THE WORD "BEHR" IN THE COLOR WHITE WITH THE WORD "PRO" IN THE COLOR ORANGE OVER A SOLID ORANGE RECTANGULAR BLOCK WITH A WHITE BEAR IN THE RIGHT CORNER OF THE RECTANGULAR BLOCK.

CLASS 37—CONSTRUCTION AND REPAIR

FOR PAINTING CONTRACTOR SERVICES (U.S. CLS. 100, 103 AND 106).

CLASS 39—TRANSPORTATION AND STORAGE

FOR DISTRIBUTION OF SERVICES, NAMELY, DELIVERY OF PAINT (U.S. CLS. 100 AND 105).

MARTHA FROMM, EXAMINING ATTORNEY

SN 85-293,065. OUR KUDOS INC., NEW HOPE, PA. FILED 4-12-2011.

It's All GOOD!

THE MARK CONSISTS OF STANDARD CHARACTERS WITHOUT CLAIM TO ANY PARTICULAR FONT, STYLE, SIZE, OR COLOR.

CLASS 35—ADVERTISING AND BUSINESS

FOR PROVIDING A WEBSITE WHERE USERS CAN POST RATINGS, REVIEWS AND RECOMMENDATIONS ON RESTAURANTS, FOOD AND WINE FOR COMMERCIAL PURPOSES (U.S. CLS. 100, 101 AND 102).

CLASS 38—COMMUNICATION

FOR MESSAGE SENDING VIA A WEBSITE (U.S. CLS. 100, 101 AND 104).

CLASS 42—SCIENTIFIC AND COMPUTER SERVICES

FOR PROVIDING A WEB SITE FEATURING TECHNOLOGY THAT ENABLES USERS TO CONNECT WITH OTHER PEOPLE IN THEIR NEIGHBORHOOD OR CITY FOR ANY NUMBER OF USER-SPECIFIED REASONS, INCLUDING PROVIDING A SERVICE OR ORGANIZING AN EVENT; PROVIDING A WEB SITE FEATURING TECHNOLOGY THAT ENABLES USERS TO SEND POSITIVE FEEDBACK AND/OR GIFTS OR OTHER REWARDS TO OTHER PEOPLE OR BUSINESSES (U.S. CLS. 100 AND 101).

MARILYN IZZI, EXAMINING ATTORNEY

SN 85-293,115. UNION ADWORKS, LLC, ROCHESTER HILLS, MI. FILED 4-12-2011.

Phadalog

THE MARK CONSISTS OF STANDARD CHARACTERS WITHOUT CLAIM TO ANY PARTICULAR FONT, STYLE, SIZE, OR COLOR.

CLASS 9—ELECTRICAL AND SCIENTIFIC APPARATUS

FOR COMPUTER SOFTWARE AND HARDWARE FOR THE WIRELESS TRANSMISSION OF ELECTRONIC CATALOG CONTENT (U.S. CLS. 21, 23, 26, 36 AND 38).

CLASS 35—ADVERTISING AND BUSINESS

FOR ADVERTISING AGENCIES, NAMELY, PROMOTING THE GOODS AND SERVICES OF OTHERS; ADVERTISING AND ADVERTISEMENT SERVICES; ADVERTISING AND COMMERCIAL INFORMATION SERVICES, VIA THE INTERNET (U.S. CLS. 100, 101 AND 102).

CLASS 38—COMMUNICATION

FOR DATA COMMUNICATION BY ELECTRONIC MAIL; ELECTRONIC MAIL; ELECTRONIC MAIL AND MESSAGING SERVICES (U.S. CLS. 100, 101 AND 104).

SETH A. RAPPAPORT, EXAMINING ATTORNEY

SN 85-293,206. AMERCABLE INCORPORATED, EL DORADO, AR. FILED 4-12-2011.

AMERRIG

THE MARK CONSISTS OF STANDARD CHARACTERS WITHOUT CLAIM TO ANY PARTICULAR FONT, STYLE, SIZE, OR COLOR.

CLASS 9—ELECTRICAL AND SCIENTIFIC APPARATUS

FOR ELECTRIC WIRES AND CABLES (U.S. CLS. 21, 23, 26, 36 AND 38).

CLASS 37—CONSTRUCTION AND REPAIR

FOR ELECTRICAL REPAIRS AND INSTALLATION OF OIL AND GAS DRILLING EQUIPMENT; MAINTENANCE AND/OR REPAIR OF TOP DRIVE MOTORS AND OIL AND GAS DRILLING EQUIPMENT (U.S. CLS. 100, 103 AND 106).

CHRIS WELLS, EXAMINING ATTORNEY

SN 85-293,242. ACTUATE CORPORATION, SAN MATEO, CA. FILED 4-12-2011.

ACTUATEONE

THE MARK CONSISTS OF STANDARD CHARACTERS WITHOUT CLAIM TO ANY PARTICULAR FONT, STYLE, SIZE, OR COLOR.

OWNER OF U.S. REG. NOS. 2,010,533 AND 2,641,931.

CLASS 9—ELECTRICAL AND SCIENTIFIC APPARATUS

FOR COMPUTER GRAPHICS SOFTWARE; COMPUTER SOFTWARE FOR USE IN BUSINESS APPLICATIONS, NAMELY, FOR USE IN INFORMATION MANAGEMENT; COMPUTER SOFTWARE USED TO MANAGE AND RESTRICT ACCESS TO ALL OR PARTS OF COMPUTERIZED DATABASES; COMPUTER SOFTWARE USED TO CUSTOMIZE USERS' ACCESS, USE AND REPORTING RIGHTS FOR ALL OR PARTS OF A COMPUTERIZED DATABASE; COMPUTER SOFTWARE FOR GENERAL USE FOR USE IN MULTI-TIERED APPLICATION DATA RETRIEVAL, MANAGEMENT, ANALYSIS AND REPORTING; AND COMPUTER E-COMMERCE SOFTWARE TO ALLOW USERS TO PERFORM ELECTRONIC BUSINESS TRANSACTIONS VIA A GLOBAL COMPUTER NETWORK; DESKTOP PUBLISHING SOFTWARE (U.S. CLS. 21, 23, 26, 36 AND 38).

FIRST USE 9-30-2010; IN COMMERCE 9-30-2010.

CLASS 42—SCIENTIFIC AND COMPUTER SERVICES

FOR COMPUTER SOFTWARE CONSULTING; COMPUTER SOFTWARE INSTALLATION AND MAINTENANCE (U.S. CLS. 100 AND 101).

FIRST USE 10-8-2010; IN COMMERCE 10-8-2010.
SHANNON TWOHIG, EXAMINING ATTORNEY

SN 85-293,246. CELEBRITY CHRYSTALS LLC, STATEN ISLAND, NY. FILED 4-12-2011.

CHRISTGIRL

THE MARK CONSISTS OF STANDARD CHARACTERS WITHOUT CLAIM TO ANY PARTICULAR FONT, STYLE, SIZE, OR COLOR.

CLASS 16—PAPER GOODS AND PRINTED MATTER

FOR MAGAZINES FEATURING FASHION (U.S. CLS. 2, 5, 22, 23, 29, 37, 38 AND 50).

CLASS 41—EDUCATION AND ENTERTAINMENT

FOR ENTERTAINMENT IN THE NATURE OF ONGOING TELEVISION PROGRAMS IN THE FIELD OF VARIETY (U.S. CLS. 100, 101 AND 107).

REBECCA SMITH, EXAMINING ATTORNEY

SN 85-293,252. COMMUNITY HOSPITAL OF THE MONTEREY PENINSULA, MONTEREY, CA. FILED 4-12-2011.



OWNER OF U.S. REG. NOS. 2,460,966, 2,788,726 AND OTHERS.

NO CLAIM IS MADE TO THE EXCLUSIVE RIGHT TO USE "PENINSULA WELLNESS CENTER" AND "COMMUNITY HOSPITAL", APART FROM THE MARK AS SHOWN.

THE MARK CONSISTS OF A STYLIZED PERSON AND A FLOURISH ABOVE THE STYLIZED WORDING PENINSULA WELLNESS CENTER ABOVE A CONCENTRIC SQUARE DESIGN AND THE STYLIZED WORDING COMMUNITY HOSPITAL OF THE MONTEREY PENINSULA.

SEC. 2(F) AS TO "COMMUNITY HOSPITAL OF THE MONTEREY PENINSULA".

CLASS 41—EDUCATION AND ENTERTAINMENT

FOR PROVIDING FITNESS AND EXERCISE FACILITIES; CONDUCTING FITNESS CLASSES; PROVIDING SWIMMING POOLS; PHYSICAL FITNESS CONSULTATION (U.S. CLS. 100, 101 AND 107).

CLASS 44—MEDICAL, BEAUTY AND AGRICULTURAL SERVICES

FOR HEALTHCARE SERVICES, NAMELY WELLNESS PROGRAMS; MEDICAL SERVICES; MEDICAL TESTING SERVICES, NAMELY MEDICAL DIAGNOSTIC TESTING, FITNESS EVALUATION, AND EVALUATION OF HEALTH RISK FACTORS; PROVIDING ASSISTANCE AND CONSULTATION TO INDIVIDUALS TO HELP TO IMPROVE THEIR HEALTH AND REDUCE THEIR HEALTH RISKS BY MAKING SUSTAINABLE LIFESTYLE, EXERCISE, AND NUTRITIONAL CHANGES; WELLNESS AND HEALTH RELATED CONSULTING SERVICES; MASSAGE THERAPY SERVICES (U.S. CLS. 100 AND 101).

JOHN WILKE, EXAMINING ATTORNEY

SN 85-293,268. SILVER LAKE COLLEGE OF THE HOLY FAMILY, INC., MANITOWOC, WI. FILED 4-12-2011.

LOVENOTES

THE MARK CONSISTS OF STANDARD CHARACTERS WITHOUT CLAIM TO ANY PARTICULAR FONT, STYLE, SIZE, OR COLOR.

OWNER OF U.S. REG. NO. 2,797,692.

CLASS 9—ELECTRICAL AND SCIENTIFIC APPARATUS

FOR VIDEO TAPES, CDS AND AUDIO CASSETTES FEATURING INSTRUCTIONAL MATERIAL IN THE FIELD OF MUSIC (U.S. CLS. 21, 23, 26, 36 AND 38).

FIRST USE 0-0-1989; IN COMMERCE 0-0-1989.

CLASS 16—PAPER GOODS AND PRINTED MATTER

FOR MANUAL CONTAINING INSTRUCTIONS, LESSON PLANS AND MUSIC FOR MUSIC EDUCATION COURSE (U.S. CLS. 2, 5, 22, 23, 29, 37, 38 AND 50).

FIRST USE 0-0-1989; IN COMMERCE 0-0-1989.

DAVID COLLIER, EXAMINING ATTORNEY

SN 85-293,321. CATHOLIC HEALTHCARE WEST, SAN FRANCISCO, CA. FILED 4-12-2011.

CHAMP

THE MARK CONSISTS OF STANDARD CHARACTERS WITHOUT CLAIM TO ANY PARTICULAR FONT, STYLE, SIZE, OR COLOR.

CLASS 41—EDUCATION AND ENTERTAINMENT

FOR EDUCATIONAL SERVICES, NAMELY, PROVIDING COURSES OF INSTRUCTION IN THE NATURE OF A HEALTH PROGRAM TO ASSIST THOSE WHO SUFFER FROM CONGESTIVE HEART FAILURE AND DISTRIBUTING COURSE MATERIAL IN CONNECTION THEREWITH (U.S. CLS. 100, 101 AND 107).

FIRST USE 7-0-1997; IN COMMERCE 7-0-1997.

CLASS 42—SCIENTIFIC AND COMPUTER SERVICES

FOR MEDICAL CARE SERVICES, NAMELY, A PROGRAM TO TREAT PERSONS WHO SUFFER FROM CONGESTIVE HEART FAILURE (U.S. CLS. 100 AND 101).

FIRST USE 7-0-1997; IN COMMERCE 7-0-1997.
 NAAKWAMA ANKRAH, EXAMINING ATTORNEY

SN 85-293,354. SCHOOLBAGS FOR KIDS, LLC, SAN FRANCISCO, CA. FILED 4-12-2011.



THE MARK CONSISTS OF A BEE WEARING A BACKPACK.

CLASS 16—PAPER GOODS AND PRINTED MATTER

FOR BOOKMARKS; CRAYONS; ERASERS; FOLDERS; GLUE FOR THE OFFICE; HIGHLIGHTER PENS; LUNCH BAGS; MARKERS; MECHANICAL PENCILS; NOTEBOOKS; OFFICE GLUES; PAPER; PAPER CLIPS; PENCIL SHARPENERS; PENCILS; PENS; PROTRACTORS; WRITING GRIPS; WRITING INSTRUMENTS (U.S. CLS. 2, 5, 22, 23, 29, 37, 38 AND 50).

CLASS 18—LEATHER GOODS

FOR BACK PACKS; CARRY-ON BAGS; FANNY PACKS; HANDBAGS; KNAP SACKS; OVERNIGHT BAGS; PURSES; SCHOOL BAGS; SUITCASES; TOTE BAGS; UMBRELLAS; WALLET (U.S. CLS. 1, 2, 3, 22 AND 41).

MICHAEL WEBSTER, EXAMINING ATTORNEY

ActuateOne

SN 85-293,334. ACTUATE CORPORATION, SAN MATEO, CA. FILED 4-12-2011.

OWNER OF U.S. REG. NOS. 2,010,533 AND 2,641,931.
 THE MARK CONSISTS OF STYLIZED "ACTUATEONE" MARK.

CLASS 9—ELECTRICAL AND SCIENTIFIC APPARATUS

FOR COMPUTER GRAPHICS SOFTWARE; COMPUTER SOFTWARE FOR USE IN BUSINESS APPLICATIONS, NAMELY, FOR USE IN INFORMATION MANAGEMENT; COMPUTER SOFTWARE USED TO MANAGE AND RESTRICT ACCESS TO ALL OR PARTS OF COMPUTERIZED DATABASES; COMPUTER SOFTWARE USED TO CUSTOMIZE USERS' ACCESS, USE AND REPORTING RIGHTS FOR ALL OR PARTS OF A COMPUTERIZED DATABASE; COMPUTER SOFTWARE FOR GENERAL USE FOR USE IN MULTI-TIERED APPLICATION DATA RETRIEVAL, MANAGEMENT, ANALYSIS AND REPORTING; AND COMPUTER E-COMMERCE SOFTWARE TO ALLOW USERS TO PERFORM ELECTRONIC BUSINESS TRANSACTIONS VIA A GLOBAL COMPUTER NETWORK; DESKTOP PUBLISHING SOFTWARE (U.S. CLS. 21, 23, 26, 36 AND 38).

FIRST USE 9-30-2010; IN COMMERCE 9-30-2010.

CLASS 42—SCIENTIFIC AND COMPUTER SERVICES

FOR COMPUTER SOFTWARE CONSULTING; COMPUTER SOFTWARE INSTALLATION AND MAINTENANCE (U.S. CLS. 100 AND 101).

FIRST USE 10-8-2010; IN COMMERCE 10-8-2010.
 SHANNON TWOHIG, EXAMINING ATTORNEY

SN 85-293,494. NOAH PERFORMANCE & CUSTOM ACCESSORIES, INC., MELVILLE, NY. FILED 4-12-2011.

KNOW WHERE YOU CAME FROM

THE MARK CONSISTS OF STANDARD CHARACTERS WITHOUT CLAIM TO ANY PARTICULAR FONT, STYLE, SIZE, OR COLOR.

CLASS 25—CLOTHING

FOR WOMEN'S, MEN'S AND CHILDREN'S CLOTHING, NAMELY, PANTS, JEANS, BOTTOMS, SHORTS, SHIRTS, TOPS, BLOUSES, SWEATERS, DRESSES, JACKETS, COATS, UNDERWEAR, SHOES, FOOTWEAR, SOCKS, HATS, SCARVES, TIES, GLOVES, BELTS (U.S. CLS. 22 AND 39).

CLASS 35—ADVERTISING AND BUSINESS

FOR CATALOG ORDERING SERVICE FEATURING AUTOMOBILE PARTS AND ACCESSORIES; ELECTRONIC CATALOG SERVICES FEATURING AUTOMOBILE PARTS AND ACCESSORIES; AND MAIL ORDER CATALOG SERVICES FEATURING AUTOMOBILE PARTS AND ACCESSORIES (U.S. CLS. 100, 101 AND 102).

VIVIAN MICZNIK FIRST, EXAMINING ATTORNEY

SN 85-293,588. PANGAEA LABORATORIES LIMITED, LONDON, UNITED KINGDOM, FILED 4-13-2011.

SN 85-293,511. SHIMP, VINCENT J., INDIANAPOLIS, IN. FILED 4-12-2011.

SKINRÖLLA

I agree with Me

THE MARK CONSISTS OF STANDARD CHARACTERS WITHOUT CLAIM TO ANY PARTICULAR FONT, STYLE, SIZE, OR COLOR.

CLASS 16—PAPER GOODS AND PRINTED MATTER

FOR BUMPER STICKERS (U.S. CLS. 2, 5, 22, 23, 29, 37, 38 AND 50).

CLASS 25—CLOTHING

FOR T-SHIRTS (U.S. CLS. 22 AND 39).
BILL DAWE, EXAMINING ATTORNEY

SN 85-293,521. STUDIO GIFT, INC., CLAY, NY. FILED 4-12-2011.

Amore

THE MARK CONSISTS OF THE STYLIZED WORD "AMORE" WITH A HEART DISPLAYED ON THE RIGHT HAND SIDE.

THE ENGLISH TRANSLATION OF "AMORE" IN THE MARK IS "LOVE".

CLASS 26—FANCY GOODS

FOR ARTIFICIAL SILK PETALS (U.S. CLS. 37, 39, 40, 42 AND 50).
FIRST USE 8-0-2006; IN COMMERCE 8-0-2006.

CLASS 31—NATURAL AGRICULTURAL PRODUCTS

FOR FREEZE DRIED FLOWERS (U.S. CLS. 1 AND 46).
FIRST USE 8-0-2006; IN COMMERCE 8-0-2006.
HANNO RITTNER, EXAMINING ATTORNEY

OWNER OF ERPN CMNTY TM OFC REG. NO. 009511973, DATED 4-1-2011, EXPIRES 11-10-2020.

THE MARK CONSISTS OF A STYLIZED VERSION OF THE WORD "SKINROLLA" WHERE THE "S" IS ROTATED, THE "I" FORMS A NEEDLE SHAPE, THE "O" HAS TWO DOTS ABOVE. BELOW THE LETTERS IS A LINE OF VARYING THICKNESS WHICH IS BROKEN BY THE NEEDLE-LIKE "I".

CLASS 3—COSMETICS AND CLEANING PREPARATIONS

FOR NON-MEDICATED TOILETRIES, NAMELY, SOAPS, SHAMPOOS, FOAM BATHS; NON-MEDICATED SKIN CARE PREPARATIONS; NON-MEDICATED SKIN EXFOLIATING PREPARATIONS; WRINKLE REMOVING SKIN CARE PREPARATIONS; MAKE-UP AND DECORATIVE COSMETIC PREPARATIONS; NON-MEDICATED SKIN AND HAIR PREPARATIONS TO PROTECT AGAINST DAMAGE FROM ELECTROMAGNETIC RADIATION; NON-MEDICATED SKIN AND HAIR PREPARATIONS TO REMOVE HAIR AND RETARD HAIR GROWTH; NON-MEDICATED HAIR CARE PREPARATIONS; TISSUES IMPREGNATED WITH COSMETIC LOTIONS (U.S. CLS. 1, 4, 6, 50, 51 AND 52).

CLASS 10—MEDICAL APPARATUS

FOR HYPODERMIC AND STERILE SURGICAL NEEDLES; DRUG AND COSMETIC DELIVERY DEVICES, NAMELY IONTOPHORESIS MACHINES, ELECTROPHORESIS MACHINES AND ARRAYS OF NEEDLES; DEVICES FOR STIMULATING WOUND REPAIR, COLLAGEN INDUCTION AND SKIN REGENERATION, NAMELY FRACTIONATED LASER MACHINES AND ARRAYS OF NEEDLES (U.S. CLS. 26, 39 AND 44).
RONALD AIKENS, EXAMINING ATTORNEY

SN 85-293,963. BODYFLASHWORLD, LLC, MIAMI, FL. FILED 4-13-2011.



THE COLOR(S) SILVER, BLACK, GREY, WHITE, TURQUOISE, TEAL, PURPLE, AND CERISE IS/ARE CLAIMED AS A FEATURE OF THE MARK.

THE MARK CONSISTS OF A BLACK RECTANGULAR BACKGROUND AGAINST WHICH APPEARS A KEYHOLE-

SHAPED BORDER IN SHADES OF SILVER, BLACK, GREY, WHITE, TEAL AND TURQUOISE WITH A STARBURST LIGHT EFFECT APPEARING AT UPPER-LEFT, WITHIN WHICH THERE IS A CERISE AND PURPLE COLOR BACKGROUND ON WHICH APPEAR THE UPPER-CASE LETTERS "B", "F", AND "W" IN VERTICAL ORDER RUNNING FROM "B" AT THE TOP TO "W" AT THE BOTTOM (THE UPPER LEFT AND RIGHT CORNERS OF THE W ARE PARTIALLY OBSCURED BY THE BORDER), AND UNDER THE "W" A STYLIZED VERSION OF THE LOWER TORSO AND LEGS OF A FEMALE WEARING HIGH HEELS.

CLASS 38—COMMUNICATION

FOR COMMUNICATIONS SERVICES, NAMELY, TRANSMITTING STREAMED SOUND AND AUDIOVISUAL RECORDINGS VIA THE INTERNET; STREAMING OF AUDIO, VISUAL AND AUDIOVISUAL MATERIAL VIA A GLOBAL COMPUTER NETWORK; STREAMING OF VIDEO MATERIAL ON THE INTERNET; VIDEO BROADCASTING SERVICES OVER THE INTERNET OR OTHER COMMUNICATIONS NETWORK FEATURING THE UPLOADED, POSTED AND TAGGED VIDEOS OF OTHERS (U.S. CLS. 100, 101 AND 104).

CLASS 41—EDUCATION AND ENTERTAINMENT

FOR ENTERTAINMENT SERVICES, NAMELY, PROVIDING A WEB SITE FEATURING NON-DOWNLOADABLE ADULT-THEMED PHOTOGRAPHS AND VIDEOS; ENTERTAINMENT SERVICES, NAMELY, PROVIDING VIRTUAL ENVIRONMENTS IN WHICH USERS CAN INTERACT FOR RECREATIONAL, LEISURE OR ENTERTAINMENT PURPOSES (U.S. CLS. 100, 101 AND 107).

CLASS 45—PERSONAL AND LEGAL SERVICES

FOR PROVIDING A SOCIAL NETWORKING WEBSITE FOR ENTERTAINMENT PURPOSES (U.S. CLS. 100 AND 101).

BRENDAN REGAN, EXAMINING ATTORNEY

SN 85-294,026. DAISY WHEEL RIBBON CO., INC., RANCHO CUCAMONGA, CA. FILED 4-13-2011.

MAKES PERFECT SENSE

THE MARK CONSISTS OF STANDARD CHARACTERS WITHOUT CLAIM TO ANY PARTICULAR FONT, STYLE, SIZE, OR COLOR.

CLASS 37—CONSTRUCTION AND REPAIR

FOR MANAGED PRINT SERVICES, NAMELY, INSTALLING, CONFIGURING, SERVICING AND REPAIRING, INCLUDING PROVISION OF REPLACEMENT PARTS AND SUPPLIES, COMPUTERS, COMPUTER HARDWARE, PRINTERS AND COPIERS IN A COMPUTER NETWORK (U.S. CLS. 100, 103 AND 106).

FIRST USE 4-1-2011; IN COMMERCE 4-1-2011.

CLASS 42—SCIENTIFIC AND COMPUTER SERVICES

FOR MANAGED PRINT SERVICES, NAMELY, MONITORING THE STATUS AND PERFORMANCE OF COMPUTERS, COMPUTER HARDWARE, PRINTERS, AND COPIERS IN A COMPUTER NETWORK (U.S. CLS. 100 AND 101).

FIRST USE 4-1-2011; IN COMMERCE 4-1-2011.
LINDSEY RUBIN, EXAMINING ATTORNEY

SN 85-294,030. WEATHERFORD/LAMB, INC., HOUSTON, TX. FILED 4-13-2011.

DELIVERING QUALITY UNDER
PRESSURE

THE MARK CONSISTS OF STANDARD CHARACTERS WITHOUT CLAIM TO ANY PARTICULAR FONT, STYLE, SIZE, OR COLOR.

CLASS 37—CONSTRUCTION AND REPAIR

FOR CLEANING OF PIPELINES AND TUBULARS USED IN THE OIL AND GAS INDUSTRY; GAS PIPELINE MAINTENANCE SERVICES, NAMELY, GAS PIPELINE EVACUATION SERVICES; OIL AND GAS INDUSTRIAL MACHINE CLEANING SERVICES; PIPELINE INSTALLATION AND REPAIR; TECHNICAL CONSULTING RELATED TO THE INSTALLATION OF OIL AND GAS EQUIPMENT, CONTROL SYSTEMS, AND MACHINERY (U.S. CLS. 100, 103 AND 106).

FIRST USE 12-31-2008; IN COMMERCE 12-31-2008.

CLASS 42—SCIENTIFIC AND COMPUTER SERVICES

FOR COMPUTER SERVICES, NAMELY, ELECTRONICALLY GATHERING, ANALYZING AND FORMATTING DATA TO TRACK, LOCATE, MONITOR AND LOG OPERATIONS IN THE OIL INDUSTRY; ENGINEERING; PIPELINE INSPECTION SERVICES; SCIENTIFIC AND TECHNOLOGICAL SERVICES, NAMELY, PRE-COMMISSIONING AND COMMISSIONING IN THE NATURE OF TESTING, ANALYZING, STUDYING, INSPECTING AND CERTIFYING IN THE FIELD OF THE OIL AND GAS INDUSTRY FOR PIPELINE INSTALLATION AND START-UP; TESTING, ANALYSIS AND EVALUATION OF THE GOODS OF OTHERS FOR THE PURPOSE OF CERTIFICATION (U.S. CLS. 100 AND 101).

FIRST USE 12-31-2008; IN COMMERCE 12-31-2008.
MATTHEW MCDOWELL, EXAMINING ATTORNEY

SN 85-294,051. WINDMILL HEALTH PRODUCTS, LLC, WEST CALDWELL, NJ. FILED 4-13-2011.

NAKED NATION

THE MARK CONSISTS OF STANDARD CHARACTERS WITHOUT CLAIM TO ANY PARTICULAR FONT, STYLE, SIZE, OR COLOR.

CLASS 3—COSMETICS AND CLEANING PREPARATIONS

FOR NON-MEDICATED SKIN CARE CREAMS AND LOTIONS (U.S. CLS. 1, 4, 6, 50, 51 AND 52).

CLASS 5—PHARMACEUTICALS

FOR DIETARY AND NUTRITIONAL SUPPLEMENTS (U.S. CLS. 6, 18, 44, 46, 51 AND 52).
LINDA POWELL, EXAMINING ATTORNEY

SN 85-294,052. WEATHERFORD/LAMB, INC., HOUSTON, TX. FILED 4-13-2011.

Denizen

THE MARK CONSISTS OF STANDARD CHARACTERS WITHOUT CLAIM TO ANY PARTICULAR FONT, STYLE, SIZE, OR COLOR.

CLASS 7—MACHINERY

FOR CLEANING MACHINES FOR OIL AND GAS INDUSTRIAL MACHINES; SKID-MOUNTED OIL AND NATURAL GAS EXTRACTING AND PROCESSING MACHINES, NAMELY, FLOODING SKID, PUMPING SKID AND HYDROTEST SKID (U.S. CLS. 13, 19, 21, 23, 31, 34 AND 35).

FIRST USE 3-9-2005; IN COMMERCE 3-9-2005.

CLASS 42—SCIENTIFIC AND COMPUTER SERVICES

FOR PIPELINE PRE-COMMISSIONING SERVICES, NAMELY, TESTING AND ANALYZING OIL AND GAS PIPELINES (U.S. CLS. 100 AND 101).

FIRST USE 3-9-2005; IN COMMERCE 3-9-2005.

MATTHEW MCDOWELL, EXAMINING ATTORNEY

SN 85-294,077. GRIFFIN, DAVID J., NEW YORK, NY. FILED 4-13-2011.

USAGE EXTERNE

THE MARK CONSISTS OF STANDARD CHARACTERS WITHOUT CLAIM TO ANY PARTICULAR FONT, STYLE, SIZE, OR COLOR.

THE ENGLISH TRANSLATION OF "USAGE EXTERNE" IN THE MARK IS "EXTERNAL USE".

CLASS 3—COSMETICS AND CLEANING PREPARATIONS

FOR PERFUME AND COLOGNE (U.S. CLS. 1, 4, 6, 50, 51 AND 52).

CLASS 25—CLOTHING

FOR CLOTHING AND ACCESSORIES FOR MEN AND WOMEN, NAMELY, COATS, JACKETS, SWEATERS, SUITS, PANTS, JEANS, SHORTS, SKIRTS, DRESSES, SHIRTS, BLOUSES, SHOES, SOCKS, BELTS, SCARVES, HATS, SWIMWEAR, UNDERWEAR, SUSPENDERS, TIES, AND CUMMERBUNDS (U.S. CLS. 22 AND 39).

REBECCA GILBERT, EXAMINING ATTORNEY

SN 85-294,110. BAYOU'S SOUTHERN BELL, ORANGE BEACH, AL. FILED 4-13-2011.

Roll Dat

THE MARK CONSISTS OF STANDARD CHARACTERS WITHOUT CLAIM TO ANY PARTICULAR FONT, STYLE, SIZE, OR COLOR.

CLASS 25—CLOTHING

FOR SHIRTS; SHORT-SLEEVED OR LONG-SLEEVED T-SHIRTS; SWEAT SHIRTS; T-SHIRTS (U.S. CLS. 22 AND 39).

CLASS 40—MATERIAL TREATMENT

FOR IMPRINTING MESSAGES ON T-SHIRTS; IMPRINTING MESSAGES ON WEARING APPAREL, ACCESSORIES AND MUGS (U.S. CLS. 100, 103 AND 106).

CHRISTINE MARTIN, EXAMINING ATTORNEY

SN 85-294,293. ASAHI KASEI FIBERS CORPORATION, OSAKA 530-8205, JAPAN, FILED 4-13-2011.

PULSHUT

THE MARK CONSISTS OF STANDARD CHARACTERS WITHOUT CLAIM TO ANY PARTICULAR FONT, STYLE, SIZE, OR COLOR.

CLASS 9—ELECTRICAL AND SCIENTIFIC APPARATUS

FOR ELECTROMAGNETIC SHIELDS FOR USE TO PREVENT OR DIMINISH ELECTROMAGNETIC INTERFERENCE IN ELECTRIC APPARATUS; SHEETS OF NON-WOVEN FABRIC FOR USE AS ELECTROMAGNETIC SHIELDS TO PREVENT OR DIMINISH ELECTROMAGNETIC INTERFERENCE IN ELECTRIC APPARATUS; SHEETS AND FILMS OF PLASTIC, RESIN AND/OR ELASTOMER FOR USE AS ELECTROMAGNETIC SHIELDS TO PREVENT OR DIMINISH ELECTROMAGNETIC INTERFERENCE IN ELECTRIC APPARATUS; ELECTRONIC COMPONENTS, NAMELY, TRANSISTORS, DIODES, THERMISTORS, HALL ELEMENTS, MAGNETORESISTIVE ELEMENTS; CHIPS; INTEGRATED CIRCUITS; LARGE-SCALE INTEGRATED CIRCUITS (U.S. CLS. 21, 23, 26, 36 AND 38).

CLASS 17—RUBBER GOODS

FOR NOISE SUPPRESSION SHEETS AND FILMS OF PLASTIC, RESIN AND/OR ELASTOMER; BOARDS, PLATES, TAPES, TUBES, SHEETS AND FILMS OF PLASTIC, RESIN AND/OR ELASTOMER FOR FURTHER MANUFACTURING; NOISE SUPPRESSION SHEETS OF NON-WOVEN FABRIC FOR FURTHER MANUFACTURING (U.S. CLS. 1, 5, 12, 13, 35 AND 50).

SN 85-294,453. DEWEY'S BAKERY, INC., WINSTON-SALEM, NC. FILED 4-13-2011.

CLASS 24—FABRICS

FOR WOVEN FABRIC; NON-WOVEN FABRIC; KNITTED FABRIC (U.S. CLS. 42 AND 50).
JOHN HWANG, EXAMINING ATTORNEY

CAKE BY DEWEY'S

THE MARK CONSISTS OF STANDARD CHARACTERS WITHOUT CLAIM TO ANY PARTICULAR FONT, STYLE, SIZE, OR COLOR.

OWNER OF U.S. REG. NO. 3,472,052.

NO CLAIM IS MADE TO THE EXCLUSIVE RIGHT TO USE "CAKE", APART FROM THE MARK AS SHOWN.

SN 85-294,434. GRAND MARK SOLUTIONS, INC., ROCKLIN, CA. FILED 4-13-2011.

CLASS 30—STAPLE FOODS

FOR BAKERY PRODUCTS (U.S. CL. 46).

CLASS 35—ADVERTISING AND BUSINESS

FOR RETAIL BAKERY SHOPS (U.S. CLS. 100, 101 AND 102).

ELISSA GARBER KON, EXAMINING ATTORNEY

HOMESTORY

THE MARK CONSISTS OF STANDARD CHARACTERS WITHOUT CLAIM TO ANY PARTICULAR FONT, STYLE, SIZE, OR COLOR.

CLASS 6—METAL GOODS

FOR METAL HARDWARE FOR DOORS, WINDOWS AND SHUTTERS, NAMELY, HINGES, PLATES, CATCHES, LATCHES AND DOOR LOCKS (U.S. CLS. 2, 12, 13, 14, 23, 25 AND 50).

SN 85-294,454. POINT VENTURE RESTAURANT GROUP, INC., DBA THE GNARLY GAR, POINT VENTURE, TX. FILED 4-13-2011.

CLASS 19—NON-METALLIC BUILDING MATERIALS

FOR NON-METAL DOORS; NON-METAL WINDOWS; NON-METAL CLOSET PARTS, NAMELY, DOORS (U.S. CLS. 1, 12, 33 AND 50).

The Gnarly Gar

THE MARK CONSISTS OF STANDARD CHARACTERS WITHOUT CLAIM TO ANY PARTICULAR FONT, STYLE, SIZE, OR COLOR.

CLASS 35—ADVERTISING AND BUSINESS

FOR RETAIL AND ONLINE RETAIL STORE SERVICES IN THE FIELDS OF DOORS, NAMELY, ENTRY DOORS, EXTERIOR DOORS, INTERIOR DOORS, CLOSET DOORS, POCKET DOORS, AND CABINET DOORS, AND WINDOWS, CABINETS AND WINDOW TREATMENTS (U.S. CLS. 100, 101 AND 102).

CLASS 41—EDUCATION AND ENTERTAINMENT

FOR ENTERTAINMENT SERVICES IN THE NATURE OF LIVE MUSICAL PERFORMANCES (U.S. CLS. 100, 101 AND 107).

FIRST USE 3-1-2011; IN COMMERCE 3-1-2011.

CLASS 37—CONSTRUCTION AND REPAIR

FOR REMODELING OF RESIDENTIAL AND COMMERCIAL BUILDINGS; INSTALLATION OF DOORS, NAMELY, ENTRY DOORS, EXTERIOR DOORS, INTERIOR DOORS, CLOSET DOORS, POCKET DOORS, AND CABINET DOORS; INSTALLATION OF WINDOWS, CABINETS, AND WINDOW TREATMENTS; INSTALLATION OF DOOR AND WINDOW HARDWARE AND RELATED ACCESSORIES (U.S. CLS. 100, 103 AND 106).
WILLIAM VERHOSEK, EXAMINING ATTORNEY

CLASS 43—HOTEL AND RESTAURANT SERVICES

FOR RESTAURANT AND BAR SERVICES (U.S. CLS. 100 AND 101).

FIRST USE 3-1-2011; IN COMMERCE 3-1-2011.
MICHAEL ENGEL, EXAMINING ATTORNEY

SN 85-294,464. DEWEY'S BAKERY, INC., WINSTON-SALEM, NC. FILED 4-13-2011.

SN 85-294,737. AHMED, ASMAU, DBA COLORMODULES, STAMFORD, CT. FILED 4-13-2011.



OWNER OF U.S. REG. NO. 3,472,052.
NO CLAIM IS MADE TO THE EXCLUSIVE RIGHT TO USE "CAKE", APART FROM THE MARK AS SHOWN.
THE MARK CONSISTS OF THE WORDS "CAKE BY DEWEY'S" OVER AND WITHIN THE SILHOUETTE OF A CUPCAKE WITH LINES RADIATING FROM THE CUPCAKE SILHOUETTE.

CLASS 30—STAPLE FOODS

FOR BAKERY PRODUCTS (U.S. CL. 46).

CLASS 35—ADVERTISING AND BUSINESS

FOR RETAIL BAKERY SHOPS (U.S. CLS. 100, 101 AND 102).

ELISSA GARBER KON, EXAMINING ATTORNEY

SN 85-294,667. PINKDINGO, INC, NORWALK, CT. FILED 4-13-2011.

PINKDINGO

THE MARK CONSISTS OF STANDARD CHARACTERS WITHOUT CLAIM TO ANY PARTICULAR FONT, STYLE, SIZE, OR COLOR.

CLASS 36—INSURANCE AND FINANCIAL

FOR CHARITABLE FUNDRAISING SERVICES, NAMELY, BY PROVIDING INDIVIDUALS WITH THE INFORMATION AND OPPORTUNITY TO MAKE MONETARY DONATIONS TO THEIR FAVORITE CHARITY (U.S. CLS. 100, 101 AND 102).
FIRST USE 10-20-2009; IN COMMERCE 2-1-2010.

CLASS 45—PERSONAL AND LEGAL SERVICES

FOR ONLINE SOCIAL NETWORKING SERVICES IN THE FIELD OF CHARITY AND FUNDRAISING (U.S. CLS. 100 AND 101).
FIRST USE 10-20-2009; IN COMMERCE 2-1-2010.
CARRIE GENOVESE, EXAMINING ATTORNEY

colorPI

THE MARK CONSISTS OF STANDARD CHARACTERS WITHOUT CLAIM TO ANY PARTICULAR FONT, STYLE, SIZE, OR COLOR.

CLASS 44—MEDICAL, BEAUTY AND AGRICULTURAL SERVICES

FOR COLOR ANALYSIS FOR COSMETIC PURPOSES (U.S. CLS. 100 AND 101).

CLASS 45—PERSONAL AND LEGAL SERVICES

FOR COLOR ANALYSIS FOR WARDROBE AND FASHION SELECTION (U.S. CLS. 100 AND 101).
GEOFFREY FOSDICK, EXAMINING ATTORNEY

SN 85-294,852. THE BURGESS GROUP, L.L.C., ALEXANDRIA, VA. FILED 4-14-2011.

BRS SEEK

THE MARK CONSISTS OF STANDARD CHARACTERS WITHOUT CLAIM TO ANY PARTICULAR FONT, STYLE, SIZE, OR COLOR.

CLASS 9—ELECTRICAL AND SCIENTIFIC APPARATUS

FOR SOFTWARE FOR PRICING CLAIMS, ANALYZING DATA, RESEARCHING RATES AND POLICIES IN THE FIELD OF MEDICARE REIMBURSEMENT AND HEALTHCARE ECONOMICS (U.S. CLS. 21, 23, 26, 36 AND 38).

CLASS 42—SCIENTIFIC AND COMPUTER SERVICES

FOR PROVIDING TEMPORARY USE OF ON-LINE NON-DOWNLOADABLE SOFTWARE FOR PRICING CLAIMS, ANALYZING DATA, RESEARCHING RATES AND POLICIES IN THE FIELD OF MEDICARE REIMBURSEMENT AND HEALTHCARE ECONOMICS (U.S. CLS. 100 AND 101).
KARANENDRA S. CHHINA, EXAMINING ATTORNEY

SN 85-294,868. HUDSON CLOTHING, LLC, COMMERCE, CA. FILED 4-14-2011.

**PEOPLE SAY I HAVE GREAT
JEANS**

THE MARK CONSISTS OF STANDARD CHARACTERS WITHOUT CLAIM TO ANY PARTICULAR FONT, STYLE, SIZE, OR COLOR.

CLASS 25—CLOTHING

FOR BOTTOMS; JEANS; PANTS; TOPS (U.S. CLS. 22 AND 39).

CLASS 35—ADVERTISING AND BUSINESS

FOR RETAIL STORE SERVICES FEATURING CLOTHING AND ACCESSORIES (U.S. CLS. 100, 101 AND 102).
WON TEAK OH, EXAMINING ATTORNEY

SN 85-294,909. KELLY ABBOTT, THOMASVILLE, GA. FILED 4-14-2011.

South Life

THE MARK CONSISTS OF STANDARD CHARACTERS WITHOUT CLAIM TO ANY PARTICULAR FONT, STYLE, SIZE, OR COLOR.

CLASS 16—PAPER GOODS AND PRINTED MATTER

FOR BUMPER STICKERS; STICKERS AND TRANSFERS (U.S. CLS. 2, 5, 22, 23, 29, 37, 38 AND 50).

CLASS 25—CLOTHING

FOR T-SHIRTS; WEARABLE GARMENTS AND CLOTHING, NAMELY, SHIRTS (U.S. CLS. 22 AND 39).
WILLIAM VERHOSEK, EXAMINING ATTORNEY

SN 85-295,077. JACKSON NATIONAL LIFE INSURANCE COMPANY, LANSING, MI. FILED 4-14-2011.

**RETHINKING THE AMERICAN
DREAM IN A NEW ECONOMY**

THE MARK CONSISTS OF STANDARD CHARACTERS WITHOUT CLAIM TO ANY PARTICULAR FONT, STYLE, SIZE, OR COLOR.

CLASS 36—INSURANCE AND FINANCIAL

FOR INVESTMENT AND FINANCIAL ADVISORY SERVICES (U.S. CLS. 100, 101 AND 102).
FIRST USE 7-31-2010; IN COMMERCE 7-31-2010.

CLASS 41—EDUCATION AND ENTERTAINMENT

FOR EDUCATIONAL SERVICES, NAMELY, CONDUCTING SEMINARS, CONFERENCES, AND/OR WORKSHOPS IN THE FIELD OF PERSONAL INVESTMENT AND FINANCIAL PLANNING AND DISTRIBUTING SEMINAR MATERIALS IN CONNECTION THEREWITH (U.S. CLS. 100, 101 AND 107).
FIRST USE 7-31-2010; IN COMMERCE 7-31-2010.
MIDGE BUTLER, EXAMINING ATTORNEY

SN 85-295,113. LIGHTNING LABELS, LLC, DENVER, CO. FILED 4-14-2011.

PRINT360

THE MARK CONSISTS OF STANDARD CHARACTERS WITHOUT CLAIM TO ANY PARTICULAR FONT, STYLE, SIZE, OR COLOR.

CLASS 16—PAPER GOODS AND PRINTED MATTER

FOR PRINTED PRODUCTS, NAMELY PRINTED BUSINESS CARDS, CONTACT CARDS CONTAINING PERSONAL CONTACT INFORMATION, POSTCARDS, ADDRESS LABELS, FOLDERS, STATIONERY, ANNOUNCEMENT CARDS, HOLIDAY CARDS, THANK-YOU CARDS, INVITATIONS, PAPER GIFT TAGS, AND INFORMATIONAL RACK CARDS, BROCHURES, FLYERS, AND DATA SHEETS, ALL CONTAINING INFORMATION SUPPLIED BY OTHERS (U.S. CLS. 2, 5, 22, 23, 29, 37, 38 AND 50).

CLASS 25—CLOTHING

FOR SHIRTS; T-SHIRTS; TANKTOPS; PANTS; SHORTS; JERSEYS; SWEATSHIRTS; SWEATPANTS; FLEECE TOPS; FLEECE BOTTOMS; TRACK SUITS; YOGA PANTS; NIGHTWEAR; PAJAMAS; HATS; CAPS; JACKETS (U.S. CLS. 22 AND 39).

CLASS 40—MATERIAL TREATMENT

FOR PRINTING SERVICES (U.S. CLS. 100, 103 AND 106).

CLASS 42—SCIENTIFIC AND COMPUTER SERVICES

FOR PROVIDING TEMPORARY USE OF ON-LINE NON-DOWNLOADABLE SOFTWARE FOR USE IN DESIGNING AND ORDERING ELECTRONIC AND PRINTED PRODUCTS, NAMELY BUSINESS CARDS, PRESENTATION GRAPHICS PROGRAM TEMPLATES, POSTCARDS, LABELS, BROCHURES, FOLDERS, STATIONERY, DATA SHEETS, FLYERS, RACK CARDS, INVITATIONS, ANNOUNCEMENTS, HOLIDAY CARDS, THANK YOU CARDS, GIFT TAGS, AND CONTACT CARDS; WEBSITE HOSTING SERVICES; GRAPHIC DESIGN SERVICES; LOGO DESIGN SERVICES (U.S. CLS. 100 AND 101).
MIDGE BUTLER, EXAMINING ATTORNEY

SN 85-295,198. THE BUGGY BUNCH, INC., VERO BEACH, FL. FILED 4-14-2011.

The Buggy Bunch

THE MARK CONSISTS OF STANDARD CHARACTERS WITHOUT CLAIM TO ANY PARTICULAR FONT, STYLE, SIZE, OR COLOR.

CLASS 35—ADVERTISING AND BUSINESS

FOR PROMOTING THE GOODS OF OTHERS, NAMELY, PROVIDING INFORMATION REGARDING DISCOUNTS, COUPONS, REBATES, VOUCHERS AND SPECIAL OFFERS FOR THE GOODS OF OTHERS (U.S. CLS. 100, 101 AND 102).
FIRST USE 7-28-2010; IN COMMERCE 1-1-2011.

CLASS 41—EDUCATION AND ENTERTAINMENT

FOR SOCIAL CLUB SERVICES, NAMELY, ARRANGING, ORGANIZING, AND HOSTING SOCIAL EVENTS, GET-TOGETHERS, AND PARTIES FOR CLUB MEMBERS (U.S. CLS. 100, 101 AND 107).
FIRST USE 7-28-2010; IN COMMERCE 1-1-2011.

CLASS 42—SCIENTIFIC AND COMPUTER SERVICES

FOR COMPUTER SERVICES, NAMELY, CREATING AN ON-LINE COMMUNITY FOR REGISTERED USERS TO PARTICIPATE IN DISCUSSIONS, GET FEEDBACK FROM THEIR PEERS, FORM VIRTUAL COMMUNITIES, AND ENGAGE IN SOCIAL NETWORKING (U.S. CLS. 100 AND 101).
FIRST USE 7-28-2010; IN COMMERCE 1-1-2011.
ANNE MADDEN, EXAMINING ATTORNEY

SN 85-295,294. PEISSIS, EDWIN, NEW YORK, NY. FILED 4-14-2011.

SOFIA
&
FRANKEE

THE MARK CONSISTS OF THE WORDS "SOFIA & FRANKEE" IN A STYLIZED FONT DESIGN.

CLASS 3—COSMETICS AND CLEANING PREPARATIONS

FOR COSMETICS; FRAGRANCES (U.S. CLS. 1, 4, 6, 50, 51 AND 52).

CLASS 9—ELECTRICAL AND SCIENTIFIC APPARATUS

FOR CELL PHONE CASES (U.S. CLS. 21, 23, 26, 36 AND 38).

CLASS 14—JEWELRY

FOR JEWELRY (U.S. CLS. 2, 27, 28 AND 50).

CLASS 16—PAPER GOODS AND PRINTED MATTER

FOR PASSPORT HOLDERS (U.S. CLS. 2, 5, 22, 23, 29, 37, 38 AND 50).

CLASS 18—LEATHER GOODS

FOR CHANGE PURSES; HANDBAGS; LUGGAGE LABEL HOLDERS; LUGGAGE TAGS; PET PRODUCTS, NAMELY, PET RESTRAINING DEVICES CONSISTING OF LEASHES, COLLARS, HARNESSES, RESTRAINING STRAPS, AND LEASHES WITH LOCKING DEVICES; PLASTIC LUGGAGE LABELS; WALLETTS (U.S. CLS. 1, 2, 3, 22 AND 41).

CLASS 25—CLOTHING

FOR BELTS; LEGGINGS; SCARVES (U.S. CLS. 22 AND 39).
WON TEAK OH, EXAMINING ATTORNEY

SN 85-295,311. MORNING COFFEE, LLC, DBA MORNING GLORY COFFEE & PASTRIES, GROSSE POINTE FARMS, MI. FILED 4-14-2011.



THE MARK CONSISTS OF A BIRD SITTING ON A TREE LIMB.

CLASS 35—ADVERTISING AND BUSINESS

FOR PASTRY SHOPS (U.S. CLS. 100, 101 AND 102).
FIRST USE 5-11-2011; IN COMMERCE 5-11-2011.

CLASS 43—HOTEL AND RESTAURANT SERVICES

FOR CAFE AND RESTAURANT SERVICES; COFFEE SHOPS (U.S. CLS. 100 AND 101).
FIRST USE 5-11-2011; IN COMMERCE 5-11-2011.
CHRISTINA SOBRAL, EXAMINING ATTORNEY

SN 85-295,456. IMAGINATION PUBLISHING L.L.C., CHICAGO, IL. FILED 4-14-2011.

HEAD WISE

THE MARK CONSISTS OF STANDARD CHARACTERS WITHOUT CLAIM TO ANY PARTICULAR FONT, STYLE, SIZE, OR COLOR.

CLASS 9—ELECTRICAL AND SCIENTIFIC APPARATUS

FOR DOWNLOADABLE ELECTRONIC PUBLICATIONS IN THE NATURE OF MAGAZINES IN THE FIELD OF MIGRAINE ADVICE DIRECTED TO HEADACHE SUFFERERS, PHYSICIANS AND TRADE ASSOCIATION MEMBERS; ELECTRONIC PUBLICATIONS, NAMELY, A MAGAZINE FEATURING MIGRAINE ADVICE DIRECTED TO HEADACHE SUFFERERS, PHYSICIANS AND TRADE ASSOCIATION MEMBERS, RECORDED ON COMPUTER MEDIA (U.S. CLS. 21, 23, 26, 36 AND 38).

SN 85-295,497. IMAGINATION PUBLISHING L.L.C., CHICAGO, IL. FILED 4-14-2011.



THE MARK CONSISTS OF THE WORD "HEAD" IN A STYLIZED FONT, ABOVE AND TO THE LEFT OF THE WORD "WISE" IN A STYLIZED FONT.

CLASS 16—PAPER GOODS AND PRINTED MATTER

FOR MAGAZINES IN THE FIELD OF MIGRAINE ADVICE DIRECTED TO HEADACHE SUFFERERS, PHYSICIANS AND TRADE ASSOCIATION MEMBERS (U.S. CLS. 2, 5, 22, 23, 29, 37, 38 AND 50).

CLASS 9—ELECTRICAL AND SCIENTIFIC APPARATUS

FOR DOWNLOADABLE ELECTRONIC PUBLICATIONS IN THE NATURE OF MAGAZINES IN THE FIELD OF MIGRAINE ADVICE DIRECTED TO HEADACHE SUFFERERS, PHYSICIANS AND TRADE ASSOCIATION MEMBERS; ELECTRONIC PUBLICATIONS, NAMELY, A MAGAZINE FEATURING MIGRAINE ADVICE DIRECTED TO HEADACHE SUFFERERS, PHYSICIANS AND TRADE ASSOCIATION MEMBERS, RECORDED ON COMPUTER MEDIA (U.S. CLS. 21, 23, 26, 36 AND 38).

CLASS 35—ADVERTISING AND BUSINESS

FOR ADVERTISING AND PROMOTIONAL SERVICES; PROMOTING THE GOODS AND SERVICES OF OTHERS BY PREPARING AND PLACING ADVERTISEMENTS IN AN ELECTRONIC MAGAZINE ACCESSED THROUGH A GLOBAL COMPUTER NETWORK (U.S. CLS. 100, 101 AND 102).

CLASS 16—PAPER GOODS AND PRINTED MATTER

FOR MAGAZINES IN THE FIELD OF MIGRAINE ADVICE DIRECTED TO HEADACHE SUFFERERS, PHYSICIANS AND TRADE ASSOCIATION MEMBERS (U.S. CLS. 2, 5, 22, 23, 29, 37, 38 AND 50).

CLASS 41—EDUCATION AND ENTERTAINMENT

FOR MAGAZINE PUBLISHING; PROVIDING A WEBSITE FEATURING NON-DOWNLOADABLE PUBLICATIONS IN THE NATURE OF MAGAZINES IN THE FIELD OF MIGRAINE ADVICE DIRECTED TO HEADACHE SUFFERERS, PHYSICIANS AND TRADE ASSOCIATION MEMBERS; PUBLISHING OF WEB MAGAZINES (U.S. CLS. 100, 101 AND 107).

LINDA M. KING, EXAMINING ATTORNEY

CLASS 35—ADVERTISING AND BUSINESS

FOR ADVERTISING AND PROMOTIONAL SERVICES; PROMOTING THE GOODS AND SERVICES OF OTHERS BY PREPARING AND PLACING ADVERTISEMENTS IN AN ELECTRONIC MAGAZINE ACCESSED THROUGH A GLOBAL COMPUTER NETWORK (U.S. CLS. 100, 101 AND 102).

SN 85-295,459. GRINNELL LEADERSHIP, INC., CHAPEL HILL, NC. FILED 4-14-2011.

RIDE THE DRAGON

THE MARK CONSISTS OF STANDARD CHARACTERS WITHOUT CLAIM TO ANY PARTICULAR FONT, STYLE, SIZE, OR COLOR.

CLASS 21—HOUSEWARES AND GLASS

FOR MUGS, NOT OF PRECIOUS METAL (U.S. CLS. 2, 13, 23, 29, 30, 33, 40 AND 50).

FIRST USE 0-0-1999; IN COMMERCE 0-0-1999.

CLASS 41—EDUCATION AND ENTERTAINMENT

FOR MAGAZINE PUBLISHING; PROVIDING A WEBSITE FEATURING NON-DOWNLOADABLE PUBLICATIONS IN THE NATURE OF MAGAZINES IN THE FIELD OF MIGRAINE ADVICE DIRECTED TO HEADACHE SUFFERERS, PHYSICIANS AND TRADE ASSOCIATION MEMBERS; PUBLISHING OF WEB MAGAZINES (U.S. CLS. 100, 101 AND 107).

LINDA M. KING, EXAMINING ATTORNEY

SN 85-295,530. ON TOP OF THE WORLD COMMUNITIES, INC., OCALA, FL. FILED 4-14-2011.

SOUTH BRANCH

CLASS 41—EDUCATION AND ENTERTAINMENT

FOR EDUCATIONAL SERVICES, NAMELY, CONDUCTING CLASSES, SEMINARS, CONFERENCES AND WORKSHOPS IN THE FIELDS OF BEHAVIOR MODIFICATION AND DISTRIBUTION OF TRAINING MATERIALS IN CONNECTION THEREWITH (U.S. CLS. 100, 101 AND 107).

FIRST USE 0-0-1999; IN COMMERCE 0-0-1999.
KAPIL BHANOT, EXAMINING ATTORNEY

THE MARK CONSISTS OF STANDARD CHARACTERS WITHOUT CLAIM TO ANY PARTICULAR FONT, STYLE, SIZE, OR COLOR.

CLASS 36—INSURANCE AND FINANCIAL

FOR REAL ESTATE BROKERAGE AND MANAGEMENT SERVICES (U.S. CLS. 100, 101 AND 102).

CLASS 37—CONSTRUCTION AND REPAIR

FOR LAND DEVELOPMENT SERVICES, NAMELY, PLANNING AND LAYING OUT OF RESIDENTIAL AND COMMERCIAL COMMUNITIES (U.S. CLS. 100, 103 AND 106).

ANNE E. GUSTASON, EXAMINING ATTORNEY

SN 85-295,815. POSPITALITY LLC, NEW YORK, NY. FILED 4-14-2011.

BREADCRUMB

THE MARK CONSISTS OF STANDARD CHARACTERS WITHOUT CLAIM TO ANY PARTICULAR FONT, STYLE, SIZE, OR COLOR.

CLASS 9—ELECTRICAL AND SCIENTIFIC APPARATUS

FOR COMPUTER SOFTWARE AND DOWNLOADABLE MOBILE COMPUTER APPARATUS APPLICATIONS FEATURING POINT OF SALE SOFTWARE FOR USE IN THE FIELDS OF RETAIL STORES, RESTAURANTS, BARS, EATING AND DRINKING ESTABLISHMENTS AND HOTELS, MOTELS AND LODGING ESTABLISHMENTS THAT ENABLES USERS TO SEND AND RECEIVE CONTENT, PRICING, ORDERS AND SALES INFORMATION DIRECTLY TO AND FROM A MOBILE DEVICE AND A CLOUD-BASED SERVER (U.S. CLS. 21, 23, 26, 36 AND 38).

CLASS 42—SCIENTIFIC AND COMPUTER SERVICES

FOR SOFTWARE AS A SERVICE (SAAS) SERVICES FEATURING POINT OF SALE SOFTWARE FOR USE IN THE FIELDS OF RETAIL STORES, RESTAURANTS, BARS, EATING AND DRINKING ESTABLISHMENTS AND HOTELS, MOTELS AND LODGING ESTABLISHMENTS THAT ENABLES USERS TO SEND AND RECEIVE CONTENT, PRICING, ORDERS AND SALES INFORMATION DIRECTLY TO AND FROM A MOBILE DEVICE AND CLOUD-BASED SERVER (U.S. CLS. 100 AND 101).

LINDSEY RUBIN, EXAMINING ATTORNEY

SN 85-295,834. B601 V2 LLC, MILLBURN, NJ. FILED 4-14-2011.

TripNeighbor

THE MARK CONSISTS OF STANDARD CHARACTERS WITHOUT CLAIM TO ANY PARTICULAR FONT, STYLE, SIZE, OR COLOR.

CLASS 9—ELECTRICAL AND SCIENTIFIC APPARATUS

FOR COMPUTER APPLICATION SOFTWARE FOR MOBILE PHONES AND TABLET COMPUTERS, NAMELY, SOFTWARE FOR CONNECTING WITH FRIENDS WHILE TRAVELING (U.S. CLS. 21, 23, 26, 36 AND 38).

CLASS 42—SCIENTIFIC AND COMPUTER SERVICES

FOR PROVIDING TEMPORARY USE OF A WEB-BASED SOFTWARE APPLICATION FOR USERS TO CONNECT WITH FRIENDS WHILE TRAVELING (U.S. CLS. 100 AND 101).

MATTHEW PAPPAS, EXAMINING ATTORNEY

SN 85-295,841. BLACHOWICZ, BRIAN JOSEPH, BALTIMORE, MD. FILED 4-14-2011.

FAILURE TO APPEAR

THE MARK CONSISTS OF STANDARD CHARACTERS WITHOUT CLAIM TO ANY PARTICULAR FONT, STYLE, SIZE, OR COLOR.

CLASS 25—CLOTHING

FOR HATS; PANTS; SHIRTS; SWEATSHIRTS (U.S. CLS. 22 AND 39).

CLASS 36—INSURANCE AND FINANCIAL

FOR BAIL BONDING (U.S. CLS. 100, 101 AND 102).

CLASS 41—EDUCATION AND ENTERTAINMENT

FOR ENTERTAINMENT, NAMELY, A CONTINUING REALITY SHOW BROADCAST OVER THE INTERNET (U.S. CLS. 100, 101 AND 107).

MATTHEW PAPPAS, EXAMINING ATTORNEY

SN 85-296,722. CEFALI, ANTHONY, BRIARWOOD, NY. FILED 4-15-2011.

SicRec

THE MARK CONSISTS OF STANDARD CHARACTERS WITHOUT CLAIM TO ANY PARTICULAR FONT, STYLE, SIZE, OR COLOR.

CLASS 25—CLOTHING

FOR SHORT-SLEEVED OR LONG-SLEEVED T-SHIRTS (U.S. CLS. 22 AND 39).

CLASS 35—ADVERTISING AND BUSINESS

FOR MARKET RESEARCH (U.S. CLS. 100, 101 AND 102).

CLASS 45—PERSONAL AND LEGAL SERVICES

FOR ON-LINE SOCIAL NETWORKING SERVICES (U.S. CLS. 100 AND 101).
KATHERINE CHANG, EXAMINING ATTORNEY

SN 85-296,775. ATCHISON FAMILY ENTERPRISES, LLC, TEMPLE, TX. FILED 4-15-2011.

SEATWAVE

SN 85-296,740. FCODER GROUP, INC., ALEXANDRIA, VA. FILED 4-15-2011.



THE MARK CONSISTS OF TWO STYLIZED JUXTAPOSING CAPITALIZED LETTERS "F" TURNED COUNTER-CLOCKWISE AT 45 DEGREES FORMING A DEPICTION OF A FISH.

CLASS 9—ELECTRICAL AND SCIENTIFIC APPARATUS

FOR COMPUTER UTILITY SOFTWARE, DOWNLOADABLE COMPUTER SOFTWARE AND COMPUTER SOFTWARE FOR DATA CONVERSION, CREATION OF DIGITAL COLLAGES AND DATA ORGANIZATION (U.S. CLS. 21, 23, 26, 36 AND 38).
FIRST USE 1-6-1998; IN COMMERCE 1-6-1998.

CLASS 42—SCIENTIFIC AND COMPUTER SERVICES

FOR COMPUTER SOFTWARE DEVELOPMENT; COMPUTER SOFTWARE DESIGN; COMPUTER SOFTWARE DEVELOPMENT AND COMPUTER PROGRAMMING DEVELOPMENT FOR OTHERS; DESIGN AND DEVELOPMENT OF COMPUTER SOFTWARE; IMAGE PROCESSING SOFTWARE DESIGN; DESIGN AND DEVELOPMENT OF SOFTWARE AND HARDWARE FOR DATA AND MULTIMEDIA CONTENT CONVERSION FROM AND TO DIFFERENT PROTOCOLS; DESIGN AND DEVELOPMENT OF SOFTWARE FOR COMPRESSION AND DECOMPRESSION OF MULTIMEDIA CONTENTS; DESIGN AND DEVELOPMENT OF SOFTWARE FOR MULTIMEDIA DATA STORING AND RECALLING; DESIGN AND DEVELOPMENT OF SOFTWARE FOR PROCESSING AND DISTRIBUTION OF MULTIMEDIA CONTENTS; RESEARCH AND DEVELOPMENT OF COMPUTER SOFTWARE; SOFTWARE AUTHORIZING; TECHNICAL SUPPORT SERVICES IN THE NATURE OF TROUBLESHOOTING OF COMPUTER SOFTWARE PROBLEMS IN CONNECTION WITH THE SOFTWARE DEVELOPMENT (U.S. CLS. 100 AND 101).

FIRST USE 1-6-1998; IN COMMERCE 1-6-1998.
DAVID H. STINE, EXAMINING ATTORNEY

THE MARK CONSISTS OF STANDARD CHARACTERS WITHOUT CLAIM TO ANY PARTICULAR FONT, STYLE, SIZE, OR COLOR.

CLASS 12—VEHICLES

FOR SEAT COVERS FOR BOATS (U.S. CLS. 19, 21, 23, 31, 35 AND 44).

CLASS 28—TOYS AND SPORTING GOODS

FOR WAKEBOARD COVERS AND BAGS (U.S. CLS. 22, 23, 38 AND 50).
ANDREA HACK, EXAMINING ATTORNEY

SN 85-298,553. WEBCETERA, L.P., FLOWER MOUND, TX. FILED 4-19-2011.

CPLIVE

THE MARK CONSISTS OF STANDARD CHARACTERS WITHOUT CLAIM TO ANY PARTICULAR FONT, STYLE, SIZE, OR COLOR.

CLASS 9—ELECTRICAL AND SCIENTIFIC APPARATUS

FOR COMPUTER SOFTWARE, NAMELY, COMPUTER SOFTWARE FOR PROVIDING A WEB-BASED PORTAL TO PROVIDE INSURANCE AGENTS AND BROKERS QUOTE INFORMATION (U.S. CLS. 21, 23, 26, 36 AND 38).
FIRST USE 12-31-2007; IN COMMERCE 12-31-2007.

CLASS 36—INSURANCE AND FINANCIAL

FOR ONLINE INSURANCE-RELATED SERVICES, NAMELY, PROVIDING A WEB-BASED PORTAL TO PROVIDE INSURANCE AGENTS AND BROKERS QUOTE INFORMATION (U.S. CLS. 100, 101 AND 102).
FIRST USE 12-31-2007; IN COMMERCE 12-31-2007.
JOHN WILKE, EXAMINING ATTORNEY

SN 85-298,624. JOSTENS, INC., MINNEAPOLIS, MN. FILED 4-19-2011.

SN 85-300,632. ENERGY MAINTENANCE SERVICES GROUP I, LLC, HOUSTON, TX. FILED 4-21-2011.

COMMITMENT 2 COMMENCEMENT

THE MARK CONSISTS OF STANDARD CHARACTERS WITHOUT CLAIM TO ANY PARTICULAR FONT, STYLE, SIZE, OR COLOR.

OWNER OF U.S. REG. NO. 3,743,980.

CLASS 16—PAPER GOODS AND PRINTED MATTER

FOR EDUCATIONAL PUBLICATIONS, NAMELY, WORKBOOKS, TEXTBOOKS, ACTIVITY BOOKS, TEACHER GUIDES, MANUALS, POSTERS, PAPER BANNERS AND EDUCATIONAL BOOKLETS IN THE FIELDS OF EDUCATION, STUDENT RETENTION, STUDENT GRADUATION RATES, AND STUDENT PREPARATION FOR GRADUATION (U.S. CLS. 2, 5, 22, 23, 29, 37, 38 AND 50).

CLASS 41—EDUCATION AND ENTERTAINMENT

FOR EDUCATION SERVICES, NAMELY, PROVIDING CLASSES, SEMINARS, FORUMS AND WORKSHOPS IN THE FIELDS OF EDUCATION, STUDENT RETENTION, STUDENT GRADUATION RATES, AND STUDENT PREPARATION FOR GRADUATION (U.S. CLS. 100, 101 AND 107).

JOHN GARTNER, EXAMINING ATTORNEY

SN 85-300,259. FRICKER'S PROGRESSIVE CONCEPTS, INC., MIAMISBURG, OH. FILED 4-20-2011.

YOU ARE ONLY ALLOWED TO
WINE IF YOU ARE A GRAPE

THE MARK CONSISTS OF STANDARD CHARACTERS WITHOUT CLAIM TO ANY PARTICULAR FONT, STYLE, SIZE, OR COLOR.

CLASS 25—CLOTHING

FOR CLOTHING, NAMELY, T-SHIRTS, SWEAT-SHIRTS, SHORTS, JACKETS AND HATS (U.S. CLS. 22 AND 39).

CLASS 43—HOTEL AND RESTAURANT SERVICES

FOR RESTAURANT AND BAR SERVICES, INCLUDING SERVICE OF WINE AND SPIRITS (U.S. CLS. 100 AND 101).

BARNEY CHARLON, EXAMINING ATTORNEY

AGIS FIELD SERVICES

THE MARK CONSISTS OF STANDARD CHARACTERS WITHOUT CLAIM TO ANY PARTICULAR FONT, STYLE, SIZE, OR COLOR.

NO CLAIM IS MADE TO THE EXCLUSIVE RIGHT TO USE "FIELD SERVICES", APART FROM THE MARK AS SHOWN.

CLASS 35—ADVERTISING AND BUSINESS

FOR OPERATION AND MANAGEMENT OF PIPELINES, NAMELY, NATURAL GAS AND LIQUID NATURAL GAS PIPELINES, FOR OTHERS IN THE INDUSTRY; COST ASSESSMENT AND CONSULTATION IN THE FIELD OF PIPELINE OPERATION AND MANAGEMENT TO COMPANIES IN THE ENERGY INDUSTRY; BUSINESS CONSULTATION ASSISTANCE IN THE FIELD OF REGULATORY COMPLIANCE (U.S. CLS. 100, 101 AND 102).

CLASS 37—CONSTRUCTION AND REPAIR

FOR GAS PIPELINE INSTALLATION, MAINTENANCE AND REPAIR AND CONSULTATION SERVICES THEREOF (U.S. CLS. 100, 103 AND 106).

CLASS 42—SCIENTIFIC AND COMPUTER SERVICES

FOR GAS PIPELINE INSPECTION SERVICES (U.S. CLS. 100 AND 101).

CLASS 45—PERSONAL AND LEGAL SERVICES

FOR REVIEWING STANDARDS AND PRACTICES TO ASSURE COMPLIANCE WITH GAS PIPELINE LAWS AND REGULATIONS AND CONSULTATION SERVICES THEREOF (U.S. CLS. 100 AND 101).

SCOTT BIBB, EXAMINING ATTORNEY

SN 85-300,987. ENERGY MAINTENANCE SERVICES GROUP I, LLC, HOUSTON, TX. FILED 4-21-2011.

EMS GULF COAST

THE MARK CONSISTS OF STANDARD CHARACTERS WITHOUT CLAIM TO ANY PARTICULAR FONT, STYLE, SIZE, OR COLOR.

OWNER OF U.S. REG. NOS. 3,274,708, 3,290,407 AND 3,848,234.

NO CLAIM IS MADE TO THE EXCLUSIVE RIGHT TO USE "GULF COAST", APART FROM THE MARK AS SHOWN.

CLASS 35—ADVERTISING AND BUSINESS

FOR OPERATION AND MANAGEMENT OF PIPELINES, NAMELY, NATURAL GAS AND LIQUID NATURAL GAS PIPELINES, FOR OTHERS IN THE INDUSTRY; COST ASSESSMENT AND CONSULTATION IN THE FIELD OF PIPELINE OPERATION AND MANAGEMENT TO COMPANIES IN THE ENERGY INDUSTRY; BUSINESS CONSULTATION ASSISTANCE IN THE FIELD OF REGULATORY COMPLIANCE (U.S. CLS. 100, 101 AND 102).

CLASS 37—CONSTRUCTION AND REPAIR

FOR GAS PIPELINE INSTALLATION, MAINTENANCE AND REPAIR AND CONSULTATION SERVICES THEREOF (U.S. CLS. 100, 103 AND 106).

CLASS 42—SCIENTIFIC AND COMPUTER SERVICES

FOR GAS PIPELINE INSPECTION SERVICES (U.S. CLS. 100 AND 101).

CLASS 45—PERSONAL AND LEGAL SERVICES

FOR REVIEWING STANDARDS AND PRACTICES TO ASSURE COMPLIANCE WITH GAS PIPELINE LAWS AND REGULATIONS AND CONSULTATION SERVICES THEREOF (U.S. CLS. 100 AND 101).
SCOTT BIBB, EXAMINING ATTORNEY

SN 85-301,006. ENERGY MAINTENANCE SERVICES GROUP I, LLC, HOUSTON, TX. FILED 4-21-2011.

EMS MEASUREMENT SERVICES

THE MARK CONSISTS OF STANDARD CHARACTERS WITHOUT CLAIM TO ANY PARTICULAR FONT, STYLE, SIZE, OR COLOR.

OWNER OF U.S. REG. NOS. 3,274,708, 3,894,737 AND OTHERS.

NO CLAIM IS MADE TO THE EXCLUSIVE RIGHT TO USE "MEASUREMENT SERVICES", APART FROM THE MARK AS SHOWN.

CLASS 35—ADVERTISING AND BUSINESS

FOR OPERATION AND MANAGEMENT OF PIPELINES, NAMELY, NATURAL GAS AND LIQUID NATURAL GAS PIPELINES, FOR OTHERS IN THE INDUSTRY; COST ASSESSMENT AND CONSULTATION IN THE FIELD OF PIPELINE OPERATION AND MANAGEMENT TO COMPANIES IN THE ENERGY INDUSTRY; BUSINESS CONSULTATION ASSISTANCE IN THE FIELD OF REGULATORY COMPLIANCE (U.S. CLS. 100, 101 AND 102).

CLASS 37—CONSTRUCTION AND REPAIR

FOR GAS PIPELINE INSTALLATION, MAINTENANCE AND REPAIR AND CONSULTATION SERVICES THEREOF (U.S. CLS. 100, 103 AND 106).

CLASS 42—SCIENTIFIC AND COMPUTER SERVICES

FOR GAS PIPELINE INSPECTION SERVICES (U.S. CLS. 100 AND 101).

CLASS 45—PERSONAL AND LEGAL SERVICES

FOR REVIEWING STANDARDS AND PRACTICES TO ASSURE COMPLIANCE WITH GAS PIPELINE LAWS AND REGULATIONS AND CONSULTATION SERVICES THEREOF (U.S. CLS. 100 AND 101).

SCOTT BIBB, EXAMINING ATTORNEY

SN 85-301,455. SWANSON TOOL CO., INC., FRANKFORT, IL. FILED 4-21-2011.

SAVAGE MAG

THE MARK CONSISTS OF STANDARD CHARACTERS WITHOUT CLAIM TO ANY PARTICULAR FONT, STYLE, SIZE, OR COLOR.

OWNER OF U.S. REG. NOS. 1,572,959 AND 3,683,541.

NO CLAIM IS MADE TO THE EXCLUSIVE RIGHT TO USE "MAG", APART FROM THE MARK AS SHOWN.

CLASS 8—HAND TOOLS

FOR HAND TOOLS, NAMELY, SQUARES (U.S. CLS. 23, 28 AND 44).

CLASS 9—ELECTRICAL AND SCIENTIFIC APPARATUS

FOR MEASURING TOOLS, NAMELY, CARPENTER'S LEVELS (U.S. CLS. 21, 23, 26, 36 AND 38).

LURIE MAYES, EXAMINING ATTORNEY

SN 85-301,773. CALIFORNIA CHARTER SCHOOLS ASSOCIATION, LOS ANGELES, CA. FILED 4-21-2011.

CCSA

THE MARK CONSISTS OF STANDARD CHARACTERS WITHOUT CLAIM TO ANY PARTICULAR FONT, STYLE, SIZE, OR COLOR.

CLASS 35—ADVERTISING AND BUSINESS

FOR PROMOTING PUBLIC AWARENESS OF CHARTER SCHOOLS AND CHARTER SCHOOL DEVELOPMENT PROGRAMS AND DISTRIBUTION OF PRINTED MATERIALS, IN HARD COPY OR ELECTRONIC FORMAT, IN CONNECTION THEREWITH (U.S. CLS. 100, 101 AND 102).

FIRST USE 10-0-2003; IN COMMERCE 10-0-2003.

CLASS 41—EDUCATION AND ENTERTAINMENT

FOR NON-PROFIT EDUCATIONAL SERVICES, NAMELY, PROVIDING SEMINARS, WORKSHOPS AND PROGRAMS FOR INCREASING STUDENT ACHIEVEMENT AND STRENGTHENING AND EXPANDING PUBLIC CHARTER SCHOOLS AND DISTRIBUTION OF PRINTED MATERIALS, IN HARD COPY OR ELECTRONIC FORMAT, IN CONNECTION THEREWITH (U.S. CLS. 100, 101 AND 107).

FIRST USE 10-0-2003; IN COMMERCE 10-0-2003.
KAPIL BHANOT, EXAMINING ATTORNEY

CLASS 11—ENVIRONMENTAL CONTROL APPARATUS

FOR PARTS FOR HVAC EQUIPMENT FOR BUILDINGS, NAMELY, FILTER DRIERS, SIGHT GLASSES, UV LIGHT BULBS, PVC PLUMBING FITTINGS, NAMELY, COUPLINGS, ELBOWS, STREET FITTINGS, TEE COUPLINGS, REDUCERS, BIBS AND TRAPS; REFRIGERANT MANIFOLDS; SYSTEM WHOLE HOUSE AIR CLEANERS (U.S. CLS. 13, 21, 23, 31 AND 34).

TINA MAI, EXAMINING ATTORNEY

SN 85-302,558. CARRIER ENTERPRISE, LLC, ORLANDO, FL. FILED 4-22-2011.

SN 85-302,562. JACKSON NATIONAL LIFE INSURANCE COMPANY, LANSING, MI. FILED 4-22-2011.

**YOUR PRACTICE. YOUR
CLIENTS. OUR PASSION.**

TECHPURE

THE MARK CONSISTS OF STANDARD CHARACTERS WITHOUT CLAIM TO ANY PARTICULAR FONT, STYLE, SIZE, OR COLOR.

THE MARK CONSISTS OF STANDARD CHARACTERS WITHOUT CLAIM TO ANY PARTICULAR FONT, STYLE, SIZE, OR COLOR.

CLASS 35—ADVERTISING AND BUSINESS

FOR INSURANCE MARKETING CONSULTING SERVICES FOR AGENTS AND BROKERS (U.S. CLS. 100, 101 AND 102).

FIRST USE 1-31-2011; IN COMMERCE 1-31-2011.

CLASS 3—COSMETICS AND CLEANING PREPARATIONS

FOR EVAPORATOR COIL CLEANERS AND CONDENSER COIL CLEANERS FOR USE WITH HVAC EQUIPMENT FOR BUILDINGS (U.S. CLS. 1, 4, 6, 50, 51 AND 52).

CLASS 36—INSURANCE AND FINANCIAL

FOR FINANCIAL SERVICES, NAMELY, FINANCIAL PLANNING AND ADVISORY SERVICES, LIFE INSURANCE AND ANNUITY UNDERWRITING (U.S. CLS. 100, 101 AND 102).

FIRST USE 1-31-2011; IN COMMERCE 1-31-2011.
MIDGE BUTLER, EXAMINING ATTORNEY

CLASS 6—METAL GOODS

FOR COPPER TUBING; COPPER FITTINGS, NAMELY, COUPLINGS, ELBOWS, STREET FITTINGS, TEE COUPLINGS, AND REDUCERS, NAMELY, PIPES USED TO CONNECT TWO DIFFERENT SIZED PIPES TOGETHER FOR SMOOTH WELDING, ALL FOR USE WITH HVAC UNITS FOR BUILDINGS; PARTS FOR HVAC UNITS FOR BUILDINGS, NAMELY, METAL SCREWS AND METAL TIE DOWN CLIPS (U.S. CLS. 2, 12, 13, 14, 23, 25 AND 50).

CLASS 7—MACHINERY

FOR PARTS FOR HVAC UNITS FOR BUILDINGS, NAMELY, ELECTRIC MOTORS, CONDENSATE PUMPS, VACUUM PUMPS (U.S. CLS. 13, 19, 21, 23, 31, 34 AND 35).

SN 85-302,564. CARRIER ENTERPRISE, LLC, ORLANDO, FL. FILED 4-22-2011.

TechPure

CLASS 9—ELECTRICAL AND SCIENTIFIC APPARATUS

FOR ELECTRICAL PARTS FOR HVAC UNITS FOR BUILDINGS, NAMELY, WIRED POTENTIAL ELECTRICAL RELAY AND START CAPACITORS FOR BOOSTING ENERGY CAPACITY, ELECTRIC CONTACTORS, ELECTRICAL RELAYS, ELECTRIC DISCONNECT BOXES, ELECTRIC TRANSFORMERS, START ASSIST KITS COMPRISED OF START CAPACITORS, POTENTIAL ELECTRIC RELAYS, THERMOSTATS, WIRE TERMINALS, TWIST-ON ELECTRICAL WIRE CONNECTORS, HUMIDISTATS, ELECTRICAL WIRE WHIPS, LIGHTING BALLASTS, ELECTRIC DRAIN SWITCHES (U.S. CLS. 21, 23, 26, 36 AND 38).

THE MARK CONSISTS OF THE STYLIZED PHRASE "TECHPURE" WITH DASHED LINES BETWEEN THE LETTER "T" AND "H".

CLASS 3—COSMETICS AND CLEANING PREPARATIONS

FOR EVAPORATOR COIL CLEANERS AND CONDENSER COIL CLEANERS FOR USE WITH HVAC EQUIPMENT FOR BUILDINGS (U.S. CLS. 1, 4, 6, 50, 51 AND 52).

CLASS 6—METAL GOODS

FOR COPPER TUBING; COPPER FITTINGS, NAMELY, COUPLINGS, ELBOWS, STREET FITTINGS, TEE COUPLINGS, AND REDUCERS, NAMELY, PIPES USED TO CONNECT TWO DIFFERENT SIZED PIPES TOGETHER FOR SMOOTH WELDING, ALL FOR USE WITH HVAC UNITS FOR BUILDINGS; PARTS FOR HVAC UNITS FOR BUILDINGS, NAMELY, METAL SCREWS AND METAL TIE DOWN CLIPS (U.S. CLS. 2, 12, 13, 14, 23, 25 AND 50).

CLASS 7—MACHINERY

FOR PARTS FOR HVAC UNITS FOR BUILDINGS, NAMELY, ELECTRIC MOTORS, CONDENSATE PUMPS, VACUUM PUMPS (U.S. CLS. 13, 19, 21, 23, 31, 34 AND 35).

CLASS 9—ELECTRICAL AND SCIENTIFIC APPARATUS

FOR ELECTRICAL PARTS FOR HVAC UNITS FOR BUILDINGS, NAMELY, WIRED POTENTIAL ELECTRICAL RELAY AND START CAPACITORS FOR BOOSTING ENERGY CAPACITY, ELECTRIC CONTACTORS, ELECTRICAL RELAYS, ELECTRIC DISCONNECT BOXES, ELECTRIC TRANSFORMERS, START ASSIST KITS COMPRISED OF START CAPACITORS, POTENTIAL ELECTRIC RELAYS, THERMOSTATS, WIRE TERMINALS, TWIST-ON ELECTRICAL WIRE CONNECTORS, HUMIDISTATS, ELECTRICAL WIRE WHIPS, LIGHTING BALLASTS, ELECTRIC DRAIN SWITCHES (U.S. CLS. 21, 23, 26, 36 AND 38).

CLASS 11—ENVIRONMENTAL CONTROL APPARATUS

FOR PARTS FOR HVAC EQUIPMENT FOR BUILDINGS, NAMELY, FILTER DRIERS, SIGHT GLASSES, UV LIGHT BULBS, PVC PLUMBING FITTINGS, NAMELY, COUPLINGS, ELBOWS, STREET FITTINGS, TEE COUPLINGS, REDUCERS, BIBS AND TRAPS; REFRIGERANT MANIFOLDS; SYSTEM WHOLE HOUSE AIR CLEANERS (U.S. CLS. 13, 21, 23, 31 AND 34).
TINA MAI, EXAMINING ATTORNEY

SN 85-302,577. CARRIER ENTERPRISE, LLC, ORLANDO, FL. FILED 4-22-2011.

NO CLAIM IS MADE TO THE EXCLUSIVE RIGHT TO USE "AIR", APART FROM THE MARK AS SHOWN.
THE MARK CONSISTS OF STYLIZED LETTERS FOR PHRASE "AIR KNIGHT" ABOVE IMAGE OF A LANCE.

CLASS 3—COSMETICS AND CLEANING PREPARATIONS

FOR EVAPORATOR COIL CLEANERS AND CONDENSER COIL CLEANERS FOR USE WITH HVAC EQUIPMENT FOR BUILDINGS (U.S. CLS. 1, 4, 6, 50, 51 AND 52).

CLASS 6—METAL GOODS

FOR COPPER TUBING; COPPER FITTINGS, NAMELY, COUPLINGS, ELBOWS, STREET FITTINGS, TEE COUPLINGS, AND REDUCERS, NAMELY, PIPES USED TO CONNECT TWO DIFFERENT SIZED PIPES TOGETHER FOR SMOOTH WELDING, ALL FOR USE WITH HVAC UNITS FOR BUILDINGS; PARTS FOR HVAC UNITS FOR BUILDINGS, NAMELY, METAL SCREWS AND METAL TIE DOWN CLIPS (U.S. CLS. 2, 12, 13, 14, 23, 25 AND 50).

CLASS 7—MACHINERY

FOR PARTS FOR HVAC UNITS FOR BUILDINGS, NAMELY, ELECTRIC MOTORS, CONDENSATE PUMPS, VACUUM PUMPS (U.S. CLS. 13, 19, 21, 23, 31, 34 AND 35).

CLASS 9—ELECTRICAL AND SCIENTIFIC APPARATUS

FOR ELECTRICAL PARTS FOR HVAC UNITS FOR BUILDINGS, NAMELY, WIRED POTENTIAL ELECTRICAL RELAY AND START CAPACITORS FOR BOOSTING ENERGY CAPACITY, ELECTRIC CONTACTORS, ELECTRICAL RELAYS, ELECTRIC DISCONNECT BOXES, ELECTRIC TRANSFORMERS, START ASSIST KITS COMPRISED OF START CAPACITORS, POTENTIAL ELECTRIC RELAYS, THERMOSTATS, WIRE TERMINALS, TWIST-ON ELECTRICAL WIRE CONNECTORS, HUMIDISTATS, ELECTRICAL WIRE WHIPS, LIGHTING BALLASTS, ELECTRIC DRAIN SWITCHES (U.S. CLS. 21, 23, 26, 36 AND 38).

CLASS 11—ENVIRONMENTAL CONTROL APPARATUS

FOR PARTS FOR HVAC EQUIPMENT FOR BUILDINGS, NAMELY, FILTER DRIERS, SIGHT GLASSES, UV LIGHT BULBS, PVC PLUMBING FITTINGS, NAMELY, COUPLINGS, ELBOWS, STREET FITTINGS, TEE COUPLINGS, REDUCERS, BIBS AND TRAPS; REFRIGERANT MANIFOLDS; SYSTEM MOUNTED WHOLE AIR PURIFIER (U.S. CLS. 13, 21, 23, 31 AND 34).
TINA MAI, EXAMINING ATTORNEY

SN 85-302,621. FRICKER'S PROGRESSIVE CONCEPTS, INC., MIAMISBURG, OH. FILED 4-22-2011.

SQUEEZE MY GRAPES AND MAKE
ME WINE

THE MARK CONSISTS OF STANDARD CHARACTERS WITHOUT CLAIM TO ANY PARTICULAR FONT, STYLE, SIZE, OR COLOR.

CLASS 25—CLOTHING

FOR CLOTHING, NAMELY, T-SHIRTS, SWEAT-SHIRTS, SHORTS, JACKETS AND HATS (U.S. CLS. 22 AND 39).

CLASS 43—HOTEL AND RESTAURANT SERVICES

FOR RESTAURANT AND BAR SERVICES, INCLUDING SERVICE OF WINE AND SPIRITS (U.S. CLS. 100 AND 101).
BARNEY CHARLON, EXAMINING ATTORNEY

SN 85-302,694. POPCAP GAMES, INC., SEATTLE, WA. FILED 4-22-2011.

PIG UP!

THE MARK CONSISTS OF STANDARD CHARACTERS WITHOUT CLAIM TO ANY PARTICULAR FONT, STYLE, SIZE, OR COLOR.

CLASS 9—ELECTRICAL AND SCIENTIFIC APPARATUS

FOR INTERACTIVE GAME SOFTWARE; COMPUTER GAME SOFTWARE; VIDEO GAME PROGRAMS AND CARTRIDGES; ELECTRONIC GAME PROGRAMS; GAME SOFTWARE FOR USE ON ANY COMPUTERIZED PLATFORM, INCLUDING GAME CONSOLES, HAND-HELD ELECTRONIC DEVICES, ELECTRONIC ENTERTAINMENT DEVICES, TELECOMMUNICATIONS DEVICES, MOBILE PHONES, AND ELECTRONIC COMMUNICATION DEVICES; DOWNLOADABLE INTERACTIVE, COMPUTER, VIDEO AND ELECTRONIC GAME PROGRAMS (U.S. CLS. 21, 23, 26, 36 AND 38).

CLASS 41—EDUCATION AND ENTERTAINMENT

FOR ENTERTAINMENT SERVICES, NAMELY, PROVIDING ON-LINE INTERACTIVE, COMPUTER, VIDEO OR ELECTRONIC GAMES; PROVIDING INTERACTIVE, COMPUTER, VIDEO OR ELECTRONIC GAMES THROUGH COMPUTER NETWORKS OR TELEVISION OR OTHER TELECOMMUNICATIONS NETWORKS; PROVIDING WEBSITES FEATURING CONTENT AND INFORMATION IN THE FIELD OF GAMES, INTERACTIVE GAME CONTENT, COMPUTER GAME CONTENT, VIDEO GAME CONTENT OR ELECTRONIC GAME CONTENT; PROVIDING TEMPORARY USE OF NON-DOWNLOADABLE INTERACTIVE GAMES, COMPUTER GAMES, VIDEO GAMES OR ELECTRONIC GAMES (U.S. CLS. 100, 101 AND 107).

CHRIS WELLS, EXAMINING ATTORNEY

SN 85-303,761. CAESARS LICENSE COMPANY, LLC, LAS VEGAS, NV. FILED 4-25-2011.

Amulet

THE MARK CONSISTS OF STANDARD CHARACTERS WITHOUT CLAIM TO ANY PARTICULAR FONT, STYLE, SIZE, OR COLOR.

CLASS 41—EDUCATION AND ENTERTAINMENT

FOR PROVIDING ENTERTAINMENT SERVICES IN THE NATURE OF CASINO GAMING; CASINO SERVICES; CONDUCTING AND PROVIDING FACILITIES FOR SPECIAL EVENTS FEATURING CASINO AND GAMING CONTESTS (U.S. CLS. 100, 101 AND 107).

CLASS 43—HOTEL AND RESTAURANT SERVICES

FOR HOTEL SERVICES; BAR AND RESTAURANT SERVICES; PROVISION OF CONFERENCE, EXHIBITION AND MEETING FACILITIES (U.S. CLS. 100 AND 101).

AMY KERTGATE, EXAMINING ATTORNEY

SN 85-303,786. CAESARS LICENSE COMPANY, LLC, LAS VEGAS, NV. FILED 4-25-2011.

Nextera

THE MARK CONSISTS OF STANDARD CHARACTERS WITHOUT CLAIM TO ANY PARTICULAR FONT, STYLE, SIZE, OR COLOR.

CLASS 41—EDUCATION AND ENTERTAINMENT

FOR PROVIDING ENTERTAINMENT SERVICES IN THE NATURE OF CASINO GAMING; CASINO SERVICES; CONDUCTING AND PROVIDING FACILITIES FOR SPECIAL EVENTS FEATURING CASINO AND GAMING CONTESTS (U.S. CLS. 100, 101 AND 107).

CLASS 43—HOTEL AND RESTAURANT SERVICES

FOR HOTEL SERVICES; BAR AND RESTAURANT SERVICES; PROVISION OF CONFERENCE, EXHIBITION AND MEETING FACILITIES (U.S. CLS. 100 AND 101).

AMY KERTGATE, EXAMINING ATTORNEY

SN 85-303,793. CAESARS LICENSE COMPANY, LLC, LAS VEGAS, NV. FILED 4-25-2011.

Gallium

THE MARK CONSISTS OF STANDARD CHARACTERS WITHOUT CLAIM TO ANY PARTICULAR FONT, STYLE, SIZE, OR COLOR.

CLASS 41—EDUCATION AND ENTERTAINMENT

FOR PROVIDING ENTERTAINMENT SERVICES IN THE NATURE OF CASINO GAMING; CASINO SERVICES; CONDUCTING AND PROVIDING FACILITIES FOR SPECIAL EVENTS FEATURING CASINO AND GAMING CONTESTS (U.S. CLS. 100, 101 AND 107).

CLASS 43—HOTEL AND RESTAURANT SERVICES

FOR HOTEL SERVICES; BAR AND RESTAURANT SERVICES; PROVISION OF CONFERENCE, EXHIBITION AND MEETING FACILITIES (U.S. CLS. 100 AND 101).

AMY KERTGATE, EXAMINING ATTORNEY

SN 85-303,827. CAESARS LICENSE COMPANY, LLC, LAS VEGAS, NV. FILED 4-25-2011.

SN 85-303,803. CAESARS LICENSE COMPANY, LLC, LAS VEGAS, NV. FILED 4-25-2011.

Populace

THE MARK CONSISTS OF STANDARD CHARACTERS WITHOUT CLAIM TO ANY PARTICULAR FONT, STYLE, SIZE, OR COLOR.

CLASS 41—EDUCATION AND ENTERTAINMENT

FOR PROVIDING ENTERTAINMENT SERVICES IN THE NATURE OF CASINO GAMING; CASINO SERVICES; CONDUCTING AND PROVIDING FACILITIES FOR SPECIAL EVENTS FEATURING CASINO AND GAMING CONTESTS (U.S. CLS. 100, 101 AND 107).

CLASS 43—HOTEL AND RESTAURANT SERVICES

FOR HOTEL SERVICES; BAR AND RESTAURANT SERVICES; PROVISION OF CONFERENCE, EXHIBITION AND MEETING FACILITIES (U.S. CLS. 100 AND 101).

AMY KERTGATE, EXAMINING ATTORNEY

SN 85-303,807. CAESARS LICENSE COMPANY, LLC, LAS VEGAS, NV. FILED 4-25-2011.

Mobius

THE MARK CONSISTS OF STANDARD CHARACTERS WITHOUT CLAIM TO ANY PARTICULAR FONT, STYLE, SIZE, OR COLOR.

CLASS 41—EDUCATION AND ENTERTAINMENT

FOR PROVIDING ENTERTAINMENT SERVICES IN THE NATURE OF CASINO GAMING; CASINO SERVICES; CONDUCTING AND PROVIDING FACILITIES FOR SPECIAL EVENTS FEATURING CASINO AND GAMING CONTESTS (U.S. CLS. 100, 101 AND 107).

CLASS 43—HOTEL AND RESTAURANT SERVICES

FOR HOTEL SERVICES; BAR AND RESTAURANT SERVICES; PROVISION OF CONFERENCE, EXHIBITION AND MEETING FACILITIES (U.S. CLS. 100 AND 101).

AMY KERTGATE, EXAMINING ATTORNEY

Realm

THE MARK CONSISTS OF STANDARD CHARACTERS WITHOUT CLAIM TO ANY PARTICULAR FONT, STYLE, SIZE, OR COLOR.

CLASS 41—EDUCATION AND ENTERTAINMENT

FOR PROVIDING ENTERTAINMENT SERVICES IN THE NATURE OF CASINO GAMING; CASINO SERVICES; CONDUCTING AND PROVIDING FACILITIES FOR SPECIAL EVENTS FEATURING CASINO AND GAMING CONTESTS (U.S. CLS. 100, 101 AND 107).

CLASS 43—HOTEL AND RESTAURANT SERVICES

FOR HOTEL SERVICES; BAR AND RESTAURANT SERVICES; PROVISION OF CONFERENCE, EXHIBITION AND MEETING FACILITIES (U.S. CLS. 100 AND 101).

AMY KERTGATE, EXAMINING ATTORNEY

SN 85-303,832. CAESARS LICENSE COMPANY, LLC, LAS VEGAS, NV. FILED 4-25-2011.

Collabra

THE MARK CONSISTS OF STANDARD CHARACTERS WITHOUT CLAIM TO ANY PARTICULAR FONT, STYLE, SIZE, OR COLOR.

CLASS 41—EDUCATION AND ENTERTAINMENT

FOR PROVIDING ENTERTAINMENT SERVICES IN THE NATURE OF CASINO GAMING; CASINO SERVICES; CONDUCTING AND PROVIDING FACILITIES FOR SPECIAL EVENTS FEATURING CASINO AND GAMING CONTESTS (U.S. CLS. 100, 101 AND 107).

CLASS 43—HOTEL AND RESTAURANT SERVICES

FOR HOTEL SERVICES; BAR AND RESTAURANT SERVICES; PROVISION OF CONFERENCE, EXHIBITION AND MEETING FACILITIES (U.S. CLS. 100 AND 101).

AMY KERTGATE, EXAMINING ATTORNEY

SN 85-304,503. PACIFIC NORTHWEST FARMERS COOPERATIVE, INC., GENESEE, ID. FILED 4-26-2011.



NO CLAIM IS MADE TO THE EXCLUSIVE RIGHT TO USE "PNW" AND "PACIFIC NORTHWEST FARMERS CO-OP", APART FROM THE MARK AS SHOWN.

THE MARK CONSISTS OF THE LETTERS "PNW" CENTERED IN A DOUBLE-WALLED CIRCLE WITH THE WORDS "PACIFIC NORTHWEST" BETWEEN THE WALLS OF THE CIRCLES ABOVE "PNW" AND THE WORDS "FARMERS CO-OP" IN A BANNER EXTENDING HORIZONTALLY ACROSS THE CIRCLE; TWO SPRIGS OF WHEAT OR BARLEY ARE BETWEEN THE WALLS OF THE CIRCLES BELOW THE BANNER.

CLASS 29—MEATS AND PROCESSED FOODS

FOR DRIED LENTILS, GARBANZO BEANS AND PEAS (U.S. CL. 46).

CLASS 31—NATURAL AGRICULTURAL PRODUCTS

FOR UNPROCESSED WHEAT; UNPROCESSED WHOLE GRAIN BARLEY (U.S. CLS. 1 AND 46).
WARREN L. OLANDRIA, EXAMINING ATTORNEY

SN 85-304,536. CHROMOCELL CORPORATION, NORTH BRUNSWICK, NJ. FILED 4-26-2011.

Chromocell Promoter

THE MARK CONSISTS OF STANDARD CHARACTERS WITHOUT CLAIM TO ANY PARTICULAR FONT, STYLE, SIZE, OR COLOR.
OWNER OF U.S. REG. NO. 2,921,583.

CLASS 30—STAPLE FOODS

FOR ANISEED FOR USE AS A FLAVORING IN FOOD AND DRINKS; CANDY CONTAINING ALCOHOLIC BEVERAGE CONTENT AND FLAVOR; CHEESE FLAVORED PUFFED CORN SNACKS; CHEESE FLAVORED SNACKS, NAMELY, CHEESE CURLS; CHEESE FLAVORED SNACKS, NAMELY, PUFFED CHEESE BALLS; CHEESE-FLAVORED CORN SNACKS; CHEMICAL FLAVORINGS FOR THE PREPARATION OF TOBACCO, NAMELY, CIGARETTE TOBACCO, CHEWING TOBACCO AND SNUFF; COFFEE FLAVORED SYRUP USED IN MAKING FOOD BEVERAGES; COOKING POWDER, NAMELY, BACON-FLAVORED SEASONING POWDER; EXTRACTS USED AS FLAVORING; FLAVOR ENHANCERS USED IN FOOD AND BEVERAGE PRODUCTS; FLAVOR-COATED POPPED POPCORN; FLAVORED AND SWEETENED GELATINS; FLAVORED ICE BLOCKS; FLAVORED ICES; FLAVORED, SWEETENED GELATIN DESSERTS; FLAVORING ADDITIVES FOR NON-NUTRITIONAL PURPOSES; FLAVORING SYRUP; FLAVORINGS; FLAVORINGS FOR BEVERAGES; FLAVORINGS FOR BEVERAGES, OTHER THAN ESSENTIAL OILS; FLAVORINGS FOR TOBACCO; FLAVORINGS, OTHER THAN ESSENTIAL OILS, FOR CAKES; FOOD ADDITIVES FOR NON-NUTRITIONAL PURPOSES FOR USE AS A FLAVORING; FOOD FLAVORINGS; FOOD FLAVORINGS, NAMELY, INFUSED OILS, NOT BEING ESSENTIAL OILS; FROZEN DESSERTS CONSISTING OF FLAVORED ICE BLOCKS WITH TOPPINGS; HOP EXTRACTS USED AS FLAVORING FOR FOODS AND BEVERAGES; MALT EXTRACTS USED AS FLAVORING; MONOSODIUM GLUTAMATE USED AS A FLAVOR ENHANCER FOR FOOD; NOODLES, SEASONINGS, EDIBLE OIL, AND FLAVORINGS COMBINED IN UNITARY PACKAGES; PROCESSED GINSENG USED AS AN HERB, SPICE OR FLAVORING; RICE, SEASONINGS, AND FLAVORINGS COMBINED IN UNITARY PACKAGES; SCENTED WATER FOR FLAVORING BEVERAGES; SEASONINGS AND FLAVORINGS FOR DOG FOODS AND CATTLE FEED; SPICES FOR THE FLAVORING OF PUMPKIN SEEDS; TEA-BASED BEVERAGES WITH FRUIT FLAVORING; VANILLA FLAVORINGS (U.S. CL. 46).

CLASS 32—LIGHT BEVERAGES

FOR COFFEE-FLAVORED ALE; COFFEE-FLAVORED BEER; COFFEE-FLAVORED SOFT DRINK; CONCENTRATES AND POWDERS USED IN THE PREPARATION OF ENERGY DRINKS AND FRUIT-FLAVORED BEVERAGES; CONCENTRATES, SYRUPS OR POWDERS FOR MAKING SOFT DRINKS OR TEA-FLAVORED BEVERAGES; FLAVORED BEERS; FLAVORED BOTTLED WATER; FLAVORED ENHANCED WATER; FLAVORED WATERS; FRUIT FLAVORED DRINKS; FRUIT FLAVORED SOFT DRINKS; FRUIT-BASED SOFT DRINKS FLAVORED WITH TEA; FRUIT-FLAVORED BEVERAGES; NON-ALCOHOLIC BEVERAGES WITH TEA FLAVOR; NON-CARBONATED, NON-ALCOHOLIC FROZEN FLAVORED BEVERAGES; SOFT DRINKS FLAVORED WITH TEA; SYRUPS FOR MAKING FRUIT-FLAVORED DRINKS (U.S. CLS. 45, 46 AND 48).

DORITT L. CARROLL, EXAMINING ATTORNEY

SN 85-304,541. CHROMOCELL CORPORATION, NORTH BRUNSWICK, NJ. FILED 4-26-2011.

Chromovert Promoter

THE MARK CONSISTS OF STANDARD CHARACTERS WITHOUT CLAIM TO ANY PARTICULAR FONT, STYLE, SIZE, OR COLOR.
OWNER OF U.S. REG. NO. 3,024,350.

CLASS 30—STAPLE FOODS

FOR ANISEED FOR USE AS A FLAVORING IN FOOD AND DRINKS; CANDY CONTAINING ALCOHOLIC BEVERAGE CONTENT AND FLAVOR; CHEESE FLAVORED PUFFED CORN SNACKS; CHEESE FLAVORED SNACKS, NAMELY, CHEESE CURLS; CHEESE FLAVORED SNACKS, NAMELY, PUFFED CHEESE BALLS; CHEESE-FLAVORED CORN SNACKS; CHEMICAL FLAVORINGS FOR THE PREPARATION OF TOBACCO, NAMELY, CIGARETTE TOBACCO, CHEWING TOBACCO AND SNUFF; COFFEE FLAVORED SYRUP USED IN MAKING FOOD BEVERAGES; COOKING POWDER, NAMELY, BACON-FLAVORED SEASONING POWDER; EXTRACTS USED AS FLAVORING; FLAVOR ENHANCERS USED IN FOOD AND BEVERAGE PRODUCTS; FLAVOR-COATED POPPED POPCORN; FLAVORED AND SWEETENED GELATINS; FLAVORED ICE BLOCKS; FLAVORED ICES; FLAVORED, SWEETENED GELATIN DESSERTS; FLAVORING ADDITIVES FOR NON-NUTRITIONAL PURPOSES; FLAVORING SYRUP; FLAVORINGS; FLAVORINGS FOR BEVERAGES; FLAVORINGS FOR BEVERAGES, OTHER THAN ESSENTIAL OILS; FLAVORINGS FOR TOBACCO; FLAVORINGS, OTHER THAN ESSENTIAL OILS, FOR CAKES; FOOD ADDITIVES FOR NON-NUTRITIONAL PURPOSES FOR USE AS A FLAVORING; FOOD FLAVORINGS; FOOD FLAVORINGS, NAMELY, INFUSED OILS, NOT BEING ESSENTIAL OILS; FROZEN DESERTS CONSISTING OF FLAVORED ICE BLOCKS WITH TOPPINGS; HOP EXTRACTS USED AS FLAVORING FOR FOODS AND BEVERAGES; MALT EXTRACTS USED AS FLAVORING; MONOSODIUM GLUTAMATE USED AS A FLAVOR ENHANCER FOR FOOD; NOODLES, SEASONINGS, EDIBLE OIL, AND FLAVORINGS COMBINED IN UNITARY PACKAGES; PROCESSED GINSENG USED AS AN HERB, SPICE OR FLAVORING; RICE, SEASONINGS, AND FLAVORINGS COMBINED IN UNITARY PACKAGES; SCENTED WATER FOR FLAVORING BEVERAGES; SEASONINGS AND FLAVORINGS FOR DOG FOODS AND CATTLE FEED; SPICES FOR THE FLAVORING OF PUMPKIN SEEDS; TEA-BASED BEVERAGES WITH FRUIT FLAVORING; VANILLA FLAVORINGS (U.S. CL. 46).

CLASS 32—LIGHT BEVERAGES

FOR COFFEE-FLAVORED ALE; COFFEE-FLAVORED BEER; COFFEE-FLAVORED SOFT DRINK; CONCENTRATES AND POWDERS USED IN THE PREPARATION OF ENERGY DRINKS AND FRUIT-FLAVORED BEVERAGES; CONCENTRATES, SYRUPS OR POWDERS FOR MAKING SOFT DRINKS OR TEA-FLAVORED BEVERAGES; FLAVORED BEERS; FLAVORED BOTTLED WATER; FLAVORED ENHANCED WATER; FLAVORED WATERS; FRUIT FLAVORED DRINKS; FRUIT FLAVORED SOFT DRINKS; FRUIT-BASED SOFT DRINKS FLAVORED WITH TEA; FRUIT-FLAVORED BEVERAGES; NON-ALCOHOLIC BEVERAGES WITH TEA FLAVOR; NON-CARBONATED, NON-ALCOHOLIC FROZEN FLAVORED BEVERAGES; SOFT DRINKS FLAVORED WITH TEA; SYRUPS FOR MAKING FRUIT-FLAVORED DRINKS (U.S. CLS. 45, 46 AND 48).

DORITT L. CARROLL, EXAMINING ATTORNEY

SN 85-305,261. ENERGY MAINTENANCE SERVICES GROUP I, LLC, HOUSTON, TX. FILED 4-26-2011.

EMS MECHANICAL & POWER SERVICES

THE MARK CONSISTS OF STANDARD CHARACTERS WITHOUT CLAIM TO ANY PARTICULAR FONT, STYLE, SIZE, OR COLOR.

OWNER OF U.S. REG. NOS. 3,274,708, 3,894,737 AND OTHERS.

NO CLAIM IS MADE TO THE EXCLUSIVE RIGHT TO USE "MECHANICAL & POWER SERVICES", APART FROM THE MARK AS SHOWN.

CLASS 35—ADVERTISING AND BUSINESS

FOR OPERATION AND MANAGEMENT OF PIPELINES, NAMELY, NATURAL GAS AND LIQUID NATURAL GAS PIPELINES, FOR OTHERS IN THE INDUSTRY; COST ASSESSMENT AND CONSULTATION IN THE FIELD OF PIPELINE OPERATION AND MANAGEMENT TO COMPANIES IN THE ENERGY INDUSTRY; BUSINESS CONSULTATION ASSISTANCE IN THE FIELD OF REGULATORY COMPLIANCE (U.S. CLS. 100, 101 AND 102).

CLASS 37—CONSTRUCTION AND REPAIR

FOR GAS PIPELINE INSTALLATION, MAINTENANCE AND REPAIR AND CONSULTATION SERVICES THEREOF (U.S. CLS. 100, 103 AND 106).

CLASS 42—SCIENTIFIC AND COMPUTER SERVICES

FOR GAS PIPELINE INSPECTION SERVICES (U.S. CLS. 100 AND 101).

CLASS 45—PERSONAL AND LEGAL SERVICES

FOR REVIEWING STANDARDS AND PRACTICES TO ASSURE COMPLIANCE WITH GAS PIPELINE LAWS AND REGULATIONS AND CONSULTATION SERVICES THEREOF (U.S. CLS. 100 AND 101).

SCOTT BIBB, EXAMINING ATTORNEY

SN 85-305,630. FEDERAL EXPRESS CORPORATION, MEMPHIS, TN. FILED 4-27-2011.

FEDEX, GET AHEAD

THE MARK CONSISTS OF STANDARD CHARACTERS WITHOUT CLAIM TO ANY PARTICULAR FONT, STYLE, SIZE, OR COLOR.

OWNER OF U.S. REG. NOS. 1,311,503, 3,874,982 AND OTHERS.

CLASS 35—ADVERTISING AND BUSINESS

FOR SMALL BUSINESS CONSULTING SERVICES (U.S. CLS. 100, 101 AND 102).

CLASS 39—TRANSPORTATION AND STORAGE

FOR PICK-UP, TRANSPORTATION, STORAGE AND DELIVERY OF DOCUMENTS, PACKAGES AND FREIGHT BY LAND AND AIR (U.S. CLS. 100 AND 105).

ELISSA GARBER KON, EXAMINING ATTORNEY

SN 85-306,744. ORE ORIGINALS, INC., LONG BEACH, CA.
FILED 4-28-2011.

SN 85-307,276. MINDSIN SYNC LIMITED, LONDON, UNITED KINGDOM, FILED 4-28-2011.

SUGARBOOGER

THE MARK CONSISTS OF STANDARD CHARACTERS WITHOUT CLAIM TO ANY PARTICULAR FONT, STYLE, SIZE, OR COLOR.

OWNER OF U.S. REG. NO. 3,254,987.

CLASS 16—PAPER GOODS AND PRINTED MATTER

FOR LUNCH BAGS (U.S. CLS. 2, 5, 22, 23, 29, 37, 38 AND 50).

FIRST USE 1-1-2009; IN COMMERCE 1-1-2009.

CLASS 21—HOUSEWARES AND GLASS

FOR BOWLS; CUPS; PLATES (U.S. CLS. 2, 13, 23, 29, 30, 33, 40 AND 50).

FIRST USE 1-31-2005; IN COMMERCE 1-31-2005.
JERI J. FICKES, EXAMINING ATTORNEY

SN 85-307,214. GIBSON OVERSEAS INC., COMMERCE, CA.
FILED 4-28-2011.



OWNER OF U.S. REG. NOS. 1,892,672, 3,123,137 AND 3,222,422.

THE MARK CONSISTS OF THE STYLIZED WORDING "GIBSON" SET ABOVE THE STYLIZED WORDING "EVERYDAY", WITH A HORIZONTAL LINE SET BETWEEN THE TERMS "GIBSON" AND "EVERYDAY", WITH A DESIGN ELEMENT COMPRISED OF A STYLIZED DEPICTION OF A ROSE SET INSIDE A CIRCLE SET ABOVE THE WORDING "GIBSON", ALL SET INSIDE A SHADED RECTANGLE.

CLASS 8—HAND TOOLS

FOR FLATWARE, NAMELY, FORKS, KNIVES, AND SPOONS (U.S. CLS. 23, 28 AND 44).

FIRST USE 1-1-2009; IN COMMERCE 1-1-2009.

CLASS 21—HOUSEWARES AND GLASS

FOR BEVERAGE GLASSWARE; DINNERWARE (U.S. CLS. 2, 13, 23, 29, 30, 33, 40 AND 50).

FIRST USE 1-1-2009; IN COMMERCE 1-1-2009.
MICHAEL GAAFAR, EXAMINING ATTORNEY

MICRODRY

THE MARK CONSISTS OF STANDARD CHARACTERS WITHOUT CLAIM TO ANY PARTICULAR FONT, STYLE, SIZE, OR COLOR.

OWNER OF U.S. REG. NO. 3,547,526.

CLASS 20—FURNITURE AND ARTICLES NOT OTHERWISE CLASSIFIED

FOR PILLOWS; MATTRESS TOPPERS; AND FIBER AND FEATHER BEDS (U.S. CLS. 2, 13, 22, 25, 32 AND 50).

CLASS 24—FABRICS

FOR PILLOW PROTECTORS; MATTRESS PROTECTORS; MATTRESS PADS; COMFORTERS; DOWN AND DOWN ALTERNATIVE BED BLANKETS; BLANKET THROWS; BED SHEETS; AND BED LINENS (U.S. CLS. 42 AND 50).

NICHOLAS COLEMAN, EXAMINING ATTORNEY

SN 85-307,642. THE CLEVELAND CLINIC FOUNDATION, CLEVELAND, OH. FILED 4-28-2011.

NEXTGEN

THE MARK CONSISTS OF STANDARD CHARACTERS WITHOUT CLAIM TO ANY PARTICULAR FONT, STYLE, SIZE, OR COLOR.

CLASS 10—MEDICAL APPARATUS

FOR KITS USED FOR COLLECTION OF SPERM CONSISTING PRIMARILY OF SPECIMEN COLLECTION CUPS, PRESERVATIVE/TRANSPORT MEDIA, ICE PACKS, AND FREEZING SLEEVES (U.S. CLS. 26, 39 AND 44).

CLASS 44—MEDICAL, BEAUTY AND AGRICULTURAL SERVICES

FOR SPERM BANK SERVICES; HUMAN SPERM DONATION SERVICES; SPERM SORTING SERVICES; LABORATORY SERVICES, NAMELY, GENETIC TESTING AND DNA ANALYSIS AND PROFILING FOR MEDICAL PURPOSES; CLINICAL SERVICES, NAMELY, GENETIC COUNSELING, DONOR SPERM SCREENING SERVICES IN THE NATURE OF MEDICAL TESTING OF SPERM, DONOR SPERM SELECTION SERVICES IN THE NATURE OF GENETIC TESTING OF SPERM, AND MALE AND FEMALE INFERTILITY AND ASSISTED REPRODUCTIVE SERVICES; MEDICAL TESTING FOR DIAGNOSTIC OR TREATMENT PURPOSES; COLLECTION AND PRESERVATION OF SPERM AND REPRODUCTIVE TISSUES (U.S. CLS. 100 AND 101).

REGINA DRUMMOND, EXAMINING ATTORNEY

SN 85-307,975. LEBANON SEABOARD CORPORATION,
LEBANON, PA. FILED 4-29-2011.

GREENSMART

THE MARK CONSISTS OF STANDARD CHARACTERS WITHOUT CLAIM TO ANY PARTICULAR FONT, STYLE, SIZE, OR COLOR.

CLASS 1—CHEMICALS

FOR FERTILIZERS; GARDEN SOIL; POTTING SOIL; ORGANIC FERTILIZERS; ORGANIC GARDEN SOIL; ORGANIC POTTING SOIL (U.S. CLS. 1, 5, 6, 10, 26 AND 46).

CLASS 5—PHARMACEUTICALS

FOR COMBINATION HERBICIDE AND FERTILIZER PREPARATION; COMBINATION HERBICIDE AND ORGANIC FERTILIZER PREPARATION; HERBICIDES (U.S. CLS. 6, 18, 44, 46, 51 AND 52).

ASMAT KHAN, EXAMINING ATTORNEY

SN 85-308,500. BLUEGREEN CORPORATION, BOCA RATON, FL. FILED 4-29-2011.

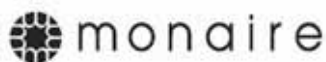

THE MARK CONSISTS OF THE WORD "MONAIRE" AND A CIRCLE DESIGN. TO THE LEFT OF THE WORD "MONAIRE" A BLACK CIRCLE APPEARS AND WITHIN THE CIRCLE ARE 4 STYLIZED LETTERS "M" WITH THE BORDER OF THE LETTER "M" OUTLINED IN WHITE. THE 4 STYLIZED LETTERS "M" FACE NORTH, SOUTH, EAST AND WEST WITHIN THE CIRCUMFERENCE OF THE CIRCLE.

CLASS 36—INSURANCE AND FINANCIAL

FOR REAL ESTATE SERVICES, NAMELY, RENTAL OF VACATION HOMES, CONDOMINIUMS, CABINS, AND VILLAS; REAL ESTATE TIME-SHARE EXCHANGE SERVICES; REAL ESTATE MANAGEMENT; REAL ESTATE MANAGEMENT CONSULTATION; REAL ESTATE OWNERSHIP EXCHANGE SERVICES, NAMELY, VACATION REAL ESTATE TIME SHARING, REAL ESTATE MANAGEMENT AND LEASING SERVICES, AND CONSULTING SERVICES FOR RESORT PROPERTIES, NAMELY, LEASING AND MANAGEMENT OF RESORT PROPERTIES; VACATION REAL ESTATE TIMESHARE SERVICES FEATURING INCENTIVE AWARD PROGRAMS; ACQUIRING LAND FOR RESIDENTIAL, TIMESHARE, RESORT AND OTHER LIVING AND RECREATIONAL USES (U.S. CLS. 100, 101 AND 102).

CLASS 39—TRANSPORTATION AND STORAGE

FOR VACATION TRAVEL CLUB SERVICES (U.S. CLS. 100 AND 105).

CLASS 43—HOTEL AND RESTAURANT SERVICES

FOR ARRANGING TEMPORARY HOUSING ACCOMMODATIONS; BOOKING OF CAMPGROUND ACCOMMODATION; CONSULTING SERVICES IN THE FIELD OF HOSPITALITY; PROVIDING TRAVEL LODGING INFORMATION SERVICES AND TRAVEL LODGING BOOKING AGENCY SERVICES FOR TRAVELERS; TRAVEL AGENCY SERVICES, NAMELY, MAKING RESERVATIONS AND BOOKING FOR TEMPORARY LODGING (U.S. CLS. 100 AND 101).

KATHRYN COWARD, EXAMINING ATTORNEY

SN 85-308,557. VONAGE MARKETING LLC, HOLMDEL, NJ. FILED 4-29-2011.



OWNER OF U.S. REG. NOS. 2,614,773, 3,740,428 AND OTHERS.

THE MARK CONSISTS OF CLOCK EVIDENCING QUARTER HOUR OVER THE WORLD MAP AND A TELEPHONE RECEIVER OVER THE CLOCK WITH THE WORDS "VONAGE" UNDER THE CLOCK.

CLASS 9—ELECTRICAL AND SCIENTIFIC APPARATUS

FOR COMPUTER TELEPHONY SOFTWARE, NAMELY, SOFTWARE APPLICATIONS FOR ESTABLISHING AND PERFORMING PHONE CALLS, VIDEO CONFERENCING AND VIRTUAL VIDEO CONFERENCING OVER A VARIETY OF NETWORKS IN THE NATURE OF THE INTERNET; DOWNLOADABLE SOFTWARE FOR USE WITH WIRELESS TELECOMMUNICATIONS DEVICES TO PROVIDE WIRELESS TRANSMISSION OF E-MAIL, TEXT, MUSIC, VIDEO, VOICE, STILL IMAGES, INFORMATION, DATA, VIDEO CONFERENCING, VIRTUAL VIDEO CONFERENCING AND OTHER CONTENT VIA THE INTERNET AND VIA WIRELESS LOCAL AREA NETWORK DEVICES; COMPUTER AND TELECOMMUNICATIONS NETWORK HUBS, SWITCHES AND ROUTERS; COMPUTER HARDWARE AND COMMUNICATIONS SOFTWARE FOR USE IN CONNECTING TELECOMMUNICATIONS EQUIPMENT, TELEPHONES, COMPUTERS, WIRED AND WIRELESS COMPUTER NETWORKS; COMPUTER SOFTWARE AND HARDWARE FOR PROVIDING TRANSMISSION AND EXCHANGE OF VOICE, VIDEO, DATA, IMAGES AND GRAPHICS IN THE FIELDS OF TELECOMMUNICATIONS, VIDEO CONFERENCING AND VIRTUAL VIDEO CONFERENCING; HARDWARE FOR TELECOMMUNICATIONS FOR CONNECTING DEVICES VIA IN-HOME PHONE AND ELECTRICAL WIRING, NAMELY, COMPUTER NETWORK HUBS, COMPUTER SWITCHES AND COMPUTER ROUTERS DESIGNED TO PROVIDE IN-HOME VOICE OVER INTERNET PROTOCOL (VOIP) COMMUNICATIONS (U.S. CLS. 21, 23, 26, 36 AND 38).

CLASS 38—COMMUNICATION

FOR TELEPHONY COMMUNICATIONS SERVICES; TELECONFERENCING SERVICES; VIDEO CONFERENCING AND VIRTUAL VIDEO CONFERENCING SERVICES (U.S. CLS. 100, 101 AND 104).

VERNA BETH RIRIE, EXAMINING ATTORNEY

SN 85-309,259. APPTERA, INC., SUNNYVALE, CA. FILED 5-1-2011.

SN 85-309,261. APPTERA, INC., SUNNYVALE, CA. FILED 5-1-2011.



THE COLOR(S) GREEN AND GREY IS/ARE CLAIMED AS A FEATURE OF THE MARK.

THE MARK CONSISTS OF "POPTUIT" WITH "POP" IN GREEN WITH THREE GREEN LINES ABOVE THE "O" AND "TUIT" IN GREY.

CLASS 9—ELECTRICAL AND SCIENTIFIC APPARATUS

FOR DOWNLOADABLE SOFTWARE IN THE NATURE OF A MOBILE APPLICATION FOR ENHANCING COMMUNICATIONS BETWEEN INDIVIDUALS AND BETWEEN CONSUMERS AND BUSINESSES INCLUDING, BUT NOT LIMITED TO, LEVERAGING VOICE AND DATA CHANNELS SIMULTANEOUSLY (U.S. CLS. 21, 23, 26, 36 AND 38).

CLASS 35—ADVERTISING AND BUSINESS

FOR ADVERTISING AND MARKETING SERVICES PROVIDED BY MEANS OF DIRECT AND INDIRECT METHODS OF MARKETING COMMUNICATIONS, NAMELY, SOCIAL MEDIA, SEARCH ENGINE MARKETING, INQUIRY MARKETING, INTERNET MARKETING, MOBILE MARKETING, GEOGRAPHIC LOCATION BASED MARKETING, BLOGGING AND OTHER FORMS OF PASSIVE, SHARABLE OR VIRAL COMMUNICATIONS CHANNELS (U.S. CLS. 100, 101 AND 102).

CLASS 38—COMMUNICATION

FOR VOICE OVER INTERNET PROTOCOL (VOIP) SERVICES; WIRELESS ELECTRONIC TRANSMISSION SIMULTANEOUSLY OF VOICE SIGNALS, DATA, FACSIMILES, IMAGES AND INFORMATIONS (U.S. CLS. 100, 101 AND 104).

CLASS 42—SCIENTIFIC AND COMPUTER SERVICES

FOR CLOUD COMPUTING FEATURING SOFTWARE FOR USE IN ENHANCING COMMUNICATIONS BETWEEN INDIVIDUALS AND BETWEEN CONSUMERS AND BUSINESSES INCLUDING, BUT NOT LIMITED TO, LEVERAGING VOICE AND DATA CHANNELS SIMULTANEOUSLY; SOFTWARE DEVELOPMENT AND PRODUCT DEVELOPMENT IN THE FIELD OF ENHANCING COMMUNICATIONS BETWEEN INDIVIDUALS AND BETWEEN CONSUMERS AND BUSINESSES INCLUDING, BUT NOT LIMITED TO, LEVERAGING VOICE AND DATA CHANNELS SIMULTANEOUSLY (U.S. CLS. 100 AND 101).

KAREN SEVERSON, EXAMINING ATTORNEY



THE COLOR(S) WHITE, GREEN, RED, YELLOW, ORANGE, LIGHT BLUE, DARK BLUE, AND PURPLE IS/ARE CLAIMED AS A FEATURE OF THE MARK.

THE MARK CONSISTS OF THREE OVERLAPPING CIRCLES ARRANGED WITH TWO ON THE BOTTOM AND ONE CENTERED OVER THEM ON THE TOP, WITH THE TOP CIRCLE IN YELLOW WITH A WHITE SMILEY FACE CONSISTING OF TWO EYES AND A SMILE FACING NINETY DEGREES COUNTERCLOCKWISE, THE BOTTOM LEFT CIRCLE IN GREEN WITH A SMALL TRIANGLE ON THE BOTTOM LEFT SIDE CREATING A SPEECH BUBBLE, AND THE BOTTOM RIGHT CIRCLE IN LIGHT BLUE WITH A TRIANGLE ON THE LEFT SIDE TO CREATE A TEARDROP SHAPE AND WITH AN OPEN WHITE CIRCLE CENTERED IN THE LARGER CIRCLE. THE OVERLAP BETWEEN THE YELLOW AND GREEN CIRCLES IS RED WITH A CURVED WHITE LINE SEPARATING THE GREEN AND RED, THE OVERLAP BETWEEN THE YELLOW AND LIGHT BLUE CIRCLES IS ORANGE, THE OVERLAP BETWEEN THE LIGHT BLUE AND GREEN CIRCLES IS DARK BLUE WITH A CURVED WHITE LINE SEPARATING THE DARK BLUE AND LIGHT BLUE, AND THE OVERLAP BETWEEN ALL THREE CIRCLES IS PURPLE.

CLASS 9—ELECTRICAL AND SCIENTIFIC APPARATUS

FOR DOWNLOADABLE SOFTWARE IN THE NATURE OF A MOBILE APPLICATION FOR ENHANCING COMMUNICATIONS BETWEEN INDIVIDUALS AND BETWEEN CONSUMERS AND BUSINESSES INCLUDING, BUT NOT LIMITED TO, LEVERAGING VOICE AND DATA CHANNELS SIMULTANEOUSLY (U.S. CLS. 21, 23, 26, 36 AND 38).

CLASS 35—ADVERTISING AND BUSINESS

FOR ADVERTISING AND MARKETING SERVICES PROVIDED BY MEANS OF DIRECT AND INDIRECT METHODS OF MARKETING COMMUNICATIONS, NAMELY, SOCIAL MEDIA, SEARCH ENGINE MARKETING, INQUIRY MARKETING, INTERNET MARKETING, MOBILE MARKETING, GEOGRAPHIC LOCATION BASED MARKETING, BLOGGING AND OTHER FORMS OF PASSIVE, SHARABLE OR VIRAL COMMUNICATIONS CHANNELS (U.S. CLS. 100, 101 AND 102).

CLASS 38—COMMUNICATION

FOR VOICE OVER INTERNET PROTOCOL (VOIP) SERVICES; WIRELESS ELECTRONIC TRANSMISSION SIMULTANEOUSLY OF VOICE SIGNALS, DATA, FACSIMILES, IMAGES AND INFORMATIONS (U.S. CLS. 100, 101 AND 104).

CLASS 42—SCIENTIFIC AND COMPUTER SERVICES

FOR CLOUD COMPUTING FEATURING SOFTWARE FOR USE IN ENHANCING COMMUNICATIONS BETWEEN INDIVIDUALS AND BETWEEN CONSUMERS AND BUSINESSES INCLUDING, BUT NOT LIMITED TO, LEVERAGING VOICE AND DATA CHANNELS SIMULTANEOUSLY; SOFTWARE DEVELOPMENT AND PRODUCT DEVELOPMENT IN THE FIELD OF ENHANCING COMMUNICATIONS BETWEEN INDIVIDUALS AND BETWEEN CONSUMERS AND BUSINESSES INCLUDING, BUT NOT LIMITED TO, LEVERAGING VOICE AND DATA CHANNELS SIMULTANEOUSLY (U.S. CLS. 100 AND 101).

KAREN SEVERSON, EXAMINING ATTORNEY

SN 85-309,846. AVISTA RENTALS, LLC, NORTH MYRTLE BEACH, SC. FILED 5-2-2011.



SN 85-309,816. SCI DIRECT, LLC, NORTH CANTON, OH. FILED 5-2-2011.

AZTECLEAN

THE MARK CONSISTS OF STANDARD CHARACTERS WITHOUT CLAIM TO ANY PARTICULAR FONT, STYLE, SIZE, OR COLOR.

CLASS 5—PHARMACEUTICALS

FOR DIET CAPSULES; DIET PILLS; DIETARY SUPPLEMENTS; MINERAL SUPPLEMENTS; NUTRITIONAL SUPPLEMENTS; VITAMIN SUPPLEMENTS; WEIGHT MANAGEMENT SUPPLEMENTS (U.S. CLS. 6, 18, 44, 46, 51 AND 52).

CLASS 16—PAPER GOODS AND PRINTED MATTER

FOR COOK BOOKS; NEWSLETTERS IN THE FIELD OF DIETING AND WEIGHT LOSS; RECIPE BOOKS; WEIGHT LOSS PROGRAM KITS CONSISTING PRIMARILY OF PRINTED BROCHURES, BOOKLETS, BOOKS, PAMPHLETS AND NEWSLETTERS ON WEIGHT LOSS AND DIETING, AND ALSO INCLUDING VITAMIN SUPPLEMENTS AND HORMONES (U.S. CLS. 2, 5, 22, 23, 29, 37, 38 AND 50).

CLASS 43—HOTEL AND RESTAURANT SERVICES

FOR PROVIDING A DATABASE IN THE FIELD OF RECIPES AND COOKING INFORMATION; PROVIDING AN ONLINE COMPUTER DATABASE TO CONSUMERS CONCERNING RECIPES, INGREDIENTS AND COOKING INFORMATION (U.S. CLS. 100 AND 101).

CLASS 44—MEDICAL, BEAUTY AND AGRICULTURAL SERVICES

FOR CONSULTING TO INDIVIDUALS AND COMMUNITIES ENGAGED IN GROUP WEIGHT LOSS PROGRAMS; PROVIDING A WEBSITE FEATURING INFORMATION AND ADVICE IN THE FIELDS OF DIET, WEIGHT LOSS, DIET PLANNING AND LIFESTYLE WELLNESS; PROVIDING INFORMATION ON MAINTAINING A HEALTHY LIFESTYLE AND LOSING WEIGHT; PROVIDING WEIGHT LOSS PROGRAM SERVICES; WEIGHT MANAGEMENT SERVICES, NAMELY, PROVIDING WEIGHT LOSS AND/OR WEIGHT MAINTENANCE PROGRAMS; WEIGHT REDUCTION DIET PLANNING AND SUPERVISION (U.S. CLS. 100 AND 101).

JENNY PARK, EXAMINING ATTORNEY

NO CLAIM IS MADE TO THE EXCLUSIVE RIGHT TO USE "MYRTLE BEACH SEASIDE RESORTS", APART FROM THE MARK AS SHOWN.

THE MARK CONSISTS OF THE WORDS "MYRTLE BEACH SEASIDE RESORTS" BELOW THE DESIGN OF A SANDDUNE, BEACH GRASS AND FENCE.

CLASS 41—EDUCATION AND ENTERTAINMENT

FOR PROVIDING A WEBSITE FEATURING INFORMATION ABOUT RECREATION AND LEISURE ACTIVITIES IN THE MYRTLE BEACH, SOUTH CAROLINA AREA, NAMELY, GOLFING, LOCAL ATTRACTIONS AND SHOPPING OPPORTUNITIES; PROVIDING ONLINE AND TELEPHONE RESERVATIONS FOR GOLFING TEE TIMES (U.S. CLS. 100, 101 AND 107).

FIRST USE 8-9-2007; IN COMMERCE 8-9-2007.

CLASS 43—HOTEL AND RESTAURANT SERVICES

FOR PROVIDING A WEBSITE FEATURING INFORMATION ABOUT TEMPORARY ACCOMMODATIONS AT HOTELS AND RESORTS; PROVIDING ONLINE AND TELEPHONE RESERVATIONS FOR HOTEL AND RESORT ACCOMMODATIONS (U.S. CLS. 100 AND 101).

FIRST USE 8-9-2007; IN COMMERCE 8-9-2007.

NICHOLAS ALTREE, EXAMINING ATTORNEY

SN 85-310,405. IMAGINATION HOLDINGS PTY LTD, ADELAIDE, AUSTRALIA, FILED 5-2-2011.

10 Second Challenge

THE MARK CONSISTS OF STANDARD CHARACTERS WITHOUT CLAIM TO ANY PARTICULAR FONT, STYLE, SIZE, OR COLOR.

CLASS 28—TOYS AND SPORTING GOODS

FOR TOYS, PLAYTHINGS AND GAMES, NAMELY, BOARD GAMES, PARTY GAMES AND PARLOR GAMES AND COMPONENT PIECES THEREOF FOR USE AS A SET AND SOLD AS A UNIT THEREWITH FOR PLAYING SUCH GAMES (U.S. CLS. 22, 23, 38 AND 50).

CLASS 41—EDUCATION AND ENTERTAINMENT

FOR PRODUCTION OF TELEVISION AND RADIO PROGRAMMES AND SEGMENTS (U.S. CLS. 100, 101 AND 107).

DAVID H. STINE, EXAMINING ATTORNEY

SN 85-311,160. LESHER, ROBERT MICHAEL, CORONA DEL MAR, CA. FILED 5-3-2011.

SN 85-310,852. HOTELS.COM, L.P., DALLAS, TX. FILED 5-3-2011.

TRIP YOUR FACE

THE MARK CONSISTS OF STANDARD CHARACTERS WITHOUT CLAIM TO ANY PARTICULAR FONT, STYLE, SIZE, OR COLOR.

CLASS 39—TRANSPORTATION AND STORAGE

FOR PROVIDING A WEBSITE FOR THE ELECTRONIC STORAGE OF PHOTOGRAPHS, TEXT, GRAPHICS AND OTHER MULTIMEDIA (U.S. CLS. 100 AND 105).

CLASS 41—EDUCATION AND ENTERTAINMENT

FOR ENTERTAINMENT SERVICES, NAMELY, PROVIDING A WEBSITE FEATURING CUSTOMIZABLE MULTIMEDIA MATERIALS FEATURING ENTERTAINMENT; ELECTRONIC PUBLICATION AND DISTRIBUTION SERVICES, NAMELY, THE PUBLICATION AND DISTRIBUTION OF USER-CUSTOMIZED AND USER-ENHANCED PHOTOGRAPHS, VIDEOS, TEXT, GRAPHICS, AND OTHER MULTIMEDIA (U.S. CLS. 100, 101 AND 107).

CLASS 42—SCIENTIFIC AND COMPUTER SERVICES

FOR PROVIDING A WEBSITE THAT GIVES MULTIPLE COMPUTER USERS THE ABILITY TO UPLOAD, MANIPULATE, CUSTOMIZE, STORE AND SHARE PHOTOGRAPHS, GRAPHICS AND OTHER MULTIMEDIA; PROVIDING A WEBSITE FOR COMPUTER USERS THE ABILITY TO MANIPULATE, CUSTOMIZE AND SHARE VIDEOS; PROVIDING ONLINE NON-DOWNLOADABLE COMPUTER SOFTWARE FOR UPLOADING, MANIPULATING, CUSTOMIZING, STORING AND SHARING PHOTOGRAPHS, VIDEO, GRAPHICS AND OTHER MULTIMEDIA OVER THE INTERNET (U.S. CLS. 100 AND 101).

CLASS 45—PERSONAL AND LEGAL SERVICES

FOR ONLINE SOCIAL NETWORKING SERVICES, NAMELY, ENABLING USERS TO DISTRIBUTE AND SHARE CUSTOMIZED PHOTOGRAPHS, VIDEO, GRAPHICS AND OTHER MULTIMEDIA THROUGH EXISTING SOCIAL NETWORKS (U.S. CLS. 100 AND 101).
CYNTHIA SLOAN, EXAMINING ATTORNEY

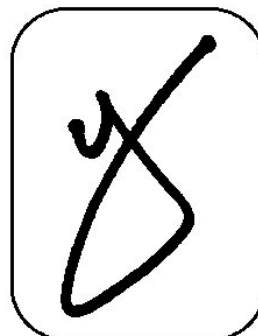

THE MARK CONSISTS OF A HAND DESIGNED "Y" INSIDE A SQUARE BOX WITH A PINLINE AROUND OUTSIDE OF BOX.

CLASS 35—ADVERTISING AND BUSINESS

FOR ON-LINE BUSINESS NETWORKING SERVICES; ON-LINE RETAIL STORE SERVICES FEATURING A WIDE VARIETY OF CONSUMER GOODS OF OTHERS (U.S. CLS. 100, 101 AND 102).

CLASS 45—PERSONAL AND LEGAL SERVICES

FOR ON-LINE SOCIAL NETWORKING SERVICES (U.S. CLS. 100 AND 101).
RUDY R. SINGLETON, EXAMINING ATTORNEY

SN 85-311,374. VISA INTERNATIONAL SERVICE ASSOCIATION, FOSTER CITY, CA. FILED 5-3-2011.

MEMORY MAPPER

THE MARK CONSISTS OF STANDARD CHARACTERS WITHOUT CLAIM TO ANY PARTICULAR FONT, STYLE, SIZE, OR COLOR.

CLASS 38—COMMUNICATION

FOR PEER-TO-PEER PHOTO SHARING SERVICES, NAMELY, ELECTRONIC TRANSMISSION OF DIGITAL PHOTO FILES AMONG INTERNET USERS (U.S. CLS. 100, 101 AND 104).

CLASS 39—TRANSPORTATION AND STORAGE

FOR PROVIDING A WEBSITE FOR THE ELECTRONIC STORAGE OF DIGITAL PHOTOGRAPHS, VIDEOS, VIDEO LOGS AND/OR DOCUMENTS (U.S. CLS. 100 AND 105).

CLASS 42—SCIENTIFIC AND COMPUTER SERVICES

FOR PROVIDING A NON-DOWNLOADABLE WEB-BASED SOFTWARE APPLICATION THAT GIVES MULTIPLE COMPUTER USERS THE ABILITY TO CREATE DIGITAL SCRAPBOOKS, AND TO UPLOAD, EDIT AND SHARE PHOTOGRAPHS, VIDEOS, VIDEO LOGS AND/OR DOCUMENTS (U.S. CLS. 100 AND 101).
JOHN GARTNER, EXAMINING ATTORNEY

SN 85-312,184. LABORATORIOS ANDROMACO S.A., SANTIAGO, CHILE, FILED 5-4-2011.

WITH YOU FROM BIRTH

SN 85-311,832. DJF ENTERPRISES, NEW YORK, NY. FILED 5-4-2011.

THE MARK CONSISTS OF STANDARD CHARACTERS WITHOUT CLAIM TO ANY PARTICULAR FONT, STYLE, SIZE, OR COLOR.

LIFE IS YOUR SET

THE MARK CONSISTS OF STANDARD CHARACTERS WITHOUT CLAIM TO ANY PARTICULAR FONT, STYLE, SIZE, OR COLOR.

CLASS 3—COSMETICS AND CLEANING PREPARATIONS

FOR COSMETICS; NON-MEDICATED SKIN CARE PREPARATIONS (U.S. CLS. 1, 4, 6, 50, 51 AND 52).

CLASS 44—MEDICAL, BEAUTY AND AGRICULTURAL SERVICES

FOR BEAUTY CONSULTATION SERVICES (U.S. CLS. 100 AND 101).
SOPHIA S. KIM, EXAMINING ATTORNEY

CLASS 3—COSMETICS AND CLEANING PREPARATIONS

FOR NON-MEDICATED LOTIONS, OINTMENTS, AND CREAMS, NAMELY, SKIN CREAMS, SKIN OINTMENTS AND SKIN LOTIONS; OINTMENTS AND CREAMS FOR SKIN CARE; COSMETICS, NAMELY, FOUNDATION MAKE UP, FACE POWDER, PRESSED POWDER, BLUSH, COVER UP CREAMS, CONCEALERS, EYE SHADOWS, EYE LINERS, EYE PENCILS, EYE TREATMENTS IN THE FORM OF CREAMS, GELS AND LOTIONS; COSMETIC LIP PRODUCTS, NAMELY, LIPSTICKS, LIP COLOR, LIP TINT, LIP GLOSS, LIP GLAZE, LIP PENCILS, LIP LINERS, LIP BALMS, LIP SHINE, AND LIP CONDITIONER; COSMETIC PREPARATIONS FOR EYELASHES, NAMELY, MASCARA, LASH TINTS, LASH ENHANCERS, LASH PRIMERS; COSMETIC PREPARATIONS FOR EYEBROWS, NAMELY, BROW PENCILS, BROW MOISTURIZING CREAM, GEL AND LOTION; NAIL CARE PREPARATIONS, NAMELY, NAIL LACQUER, NAIL POLISH, NAIL POLISH REMOVER; SKIN PREPARATIONS, NAMELY, SKIN MASKS, TONERS, TONICS, CLARIFIERS AND REFRESHERS; SOAPS FOR PERSONAL USE; SKIN CLEANSERS; FACE AND BODY POWDERS FOR PERSONAL USE; NON-MEDICATED BATH AND SHOWER PREPARATIONS, NAMELY, BATH OILS, BATH SALTS, BATH BEADS, BATH GELS, BATH GRAINS; SUN CARE PREPARATIONS, NAMELY, SUN SCREEN PREPARATIONS, SUN BLOCK PREPARATIONS, SELF TANNING PREPARATIONS; SKIN BRONZING PREPARATIONS, NAMELY, SKIN BRONZER CREAMS, LOTIONS AND GELS, COSMETIC BRONZING STICKS, BRONZING POWDERS; AFTER-SUN SOOTHING AND MOISTURIZING PREPARATIONS IN THE NATURE OF CREAMS AND LOTIONS; PRE-SHAVE AND AFTER SHAVE LOTIONS, CREAMS, BALMS, SPLASHES AND GELS; SHAVING CREAM, SHAVING GEL; NON-MEDICATED SKIN CARE PREPARATIONS; NON-MEDICATED SKIN CARE TREATMENT PREPARATIONS, NAMELY, FACIAL MOISTURIZERS, FACE CREAMS, FACE LOTIONS, FACE GELS, SKIN TONICS, EYE CREAMS, LOTIONS AND GELS; SKIN CLEANSING LOTIONS; SKIN CLEANSING CREAMS; SKIN CLEANSING GELS; FACIAL SCRUB; NON-MEDICATED ANTI-WRINKLE CREAMS, LOTIONS AND GELS, EXFOLIATING CREAMS, LOTIONS, GELS AND OILS; NON-MEDICATED SKIN REPAIR CREAMS, LOTIONS AND GELS; HAND CREAM; PREPARATIONS FOR THE BODY, NAMELY, BODY CREAM, BODY LOTION, BODY GEL, BODY OIL, BODY POWDER, BODY TONERS, BODY CLEANSERS, BODY SPRAYS AND BODY WASHES; NON-MEDICATED SKIN RENEWAL CREAMS, LOTIONS AND GELS; SKIN REFRESHERS; MAKEUP REMOVERS; PERSONAL DEODORANTS AND ANTIPERSPIRANTS; MOISTURIZING LOTIONS AND CREAMS FOR THE FACE AND BODY; ASTRINGENTS FOR COSMETIC PURPOSES; TALCUM POWDER; HAIR CARE PREPARATIONS; HAIR STYLING PREPARATIONS; HAIR SUNSCREEN PREPARATIONS; PERFUMERY, NAMELY, PERFUME, EAU DE PERFUME, EAU DE TOILETTE, COLOGNE AND ESSENTIAL OILS FOR PERSONAL USE, SCENTED OILS USED TO PRODUCE AROMAS WHEN HEATED, FRAGRANCED BODY, AND BATH AND HAIR CARE PREPARATIONS; MEDICATED SOAPS (U.S. CLS. 1, 4, 6, 50, 51 AND 52).

SN 85-312,003. GABRIELLE STUDIO, INC., NEW YORK, NY. FILED 5-4-2011.

PUREDKNY

THE MARK CONSISTS OF STANDARD CHARACTERS WITHOUT CLAIM TO ANY PARTICULAR FONT, STYLE, SIZE, OR COLOR.
OWNER OF U.S. REG. NOS. 3,187,255, 3,212,869 AND OTHERS.

CLASS 20—FURNITURE AND ARTICLES NOT OTHERWISE CLASSIFIED

FOR DECORATIVE PILLOWS (U.S. CLS. 2, 13, 22, 25, 32 AND 50).
FIRST USE 9-0-2007; IN COMMERCE 9-0-2007.

CLASS 24—FABRICS

FOR BED BLANKETS, DUVET COVERS, QUILTS, PILLOW SHAMS, BED SKIRTS, BED SHEETS, PILLOW CASES (U.S. CLS. 42 AND 50).
FIRST USE 9-0-2007; IN COMMERCE 9-0-2007.
WON TEAK OH, EXAMINING ATTORNEY

CLASS 5—PHARMACEUTICALS

FOR MEDICATED LOTIONS, OINTMENTS AND CREAMS, NAMELY, SKIN LOTIONS, SKIN OINTMENTS, SKIN CREAMS, DIAPER RASH LOTIONS, DIAPER RASH OINTMENTS AND DIAPER RASH CREAMS; BANDAGES FOR SKIN WOUNDS; MEDICAL PLASTERS; FIRST AID KITS; CAPSULES, TABLETS, GEL CAPSULES, AND PILLS SOLD EMPTY FOR PHARMACEUTICAL PURPOSES (U.S. CLS. 6, 18, 44, 46, 51 AND 52).

PAUL E. FAHRENKOPF, EXAMINING ATTORNEY

SN 85-312,241. BIKES BELONG COALITION, LTD, BOULDER, CO. FILED 5-4-2011.

FIRE UP YOUR FEET!

THE MARK CONSISTS OF STANDARD CHARACTERS WITHOUT CLAIM TO ANY PARTICULAR FONT, STYLE, SIZE, OR COLOR.

CLASS 35—ADVERTISING AND BUSINESS

FOR PROMOTING PUBLIC AWARENESS OF CHILDHOOD PHYSICAL FITNESS AND EXERCISE, NAMELY, BICYCLING AND WALKING; PUBLIC ADVOCACY TO PROMOTE AND ENCOURAGE CHILDHOOD PHYSICAL FITNESS AND EXERCISE, NAMELY, BICYCLING AND WALKING; PROVIDING INFORMATION ABOUT CHILDHOOD PHYSICAL FITNESS AND EXERCISE, NAMELY, BICYCLING AND WALKING, VIA THE INTERNET (U.S. CLS. 100, 101 AND 102).

CLASS 36—INSURANCE AND FINANCIAL

FOR PROVIDING GRANTS FOR CHILDHOOD PHYSICAL FITNESS AND EXERCISE PROGRAMS, NAMELY, BICYCLING AND WALKING; CHARITABLE FUNDRAISING TO SUPPORT CHILDHOOD PHYSICAL FITNESS AND EXERCISE PROGRAMS, NAMELY, BICYCLING AND WALKING (U.S. CLS. 100, 101 AND 102).

JEFF DEFORD, EXAMINING ATTORNEY

SN 85-312,304. FEDERAL EXPRESS CORPORATION, MEMPHIS, TN. FILED 5-4-2011.

MY FEDEX OFFICE REWARDS

THE MARK CONSISTS OF STANDARD CHARACTERS WITHOUT CLAIM TO ANY PARTICULAR FONT, STYLE, SIZE, OR COLOR.

OWNER OF U.S. REG. NOS. 3,800,207, 3,929,069 AND OTHERS.

NO CLAIM IS MADE TO THE EXCLUSIVE RIGHT TO USE "OFFICE REWARDS", APART FROM THE MARK AS SHOWN.

CLASS 9—ELECTRICAL AND SCIENTIFIC APPARATUS

FOR DOWNLOADABLE SOFTWARE FOR USE IN ORDERING, PRINTING, BINDING AND SHIPPING SERVICES (U.S. CLS. 21, 23, 26, 36 AND 38).

CLASS 35—ADVERTISING AND BUSINESS

FOR ADVERTISING AND BUSINESS SERVICES, NAMELY, PHOTOCOPYING SERVICES; WORD-PROCESSING AND TYPING SERVICES; RENTAL OF OFFICE MACHINERY AND EQUIPMENT; PHOTOCOPYING AND REPRODUCING AND COMPILING DOCUMENTS FOR OTHERS; PREPARING PUBLI-CITY DOCUMENTS FOR OTHERS; LEASE AND RENTAL OF COPY MACHINES, TYPEWRITERS AND WORD PROCESSORS (U.S. CLS. 100, 101 AND 102).

CLASS 38—COMMUNICATION

FOR COMMUNICATION SERVICES, NAMELY, ELECTRONIC MAIL SERVICES AND ELECTRONIC TRANSMISSION OF DATA AND DOCUMENTS VIA COMPUTER TERMINALS; FACSIMILE TRANSMISSION SERVICES; RENTAL OF TELEPHONE, FACSIMILE AND VIDEO TELECONFERENCING EQUIPMENT (U.S. CLS. 100, 101 AND 104).

CLASS 39—TRANSPORTATION AND STORAGE

FOR PICK-UP, WAREHOUSING, TRANSPORTATION AND DELIVERY OF DOCUMENTS, PACKAGES AND FREIGHT BY LAND AND AIR (U.S. CLS. 100 AND 105).

CLASS 40—MATERIAL TREATMENT

FOR TREATMENT OF MATERIALS, NAMELY, THE LAMINATING AND COLLATING OF DOCUMENTS, PHOTOGRAPHS, SIGNS, BANNERS, AND CERTIFICATES; ASSEMBLING OF DOCUMENTS; PHOTOGRAPHIC REPRODUCTION SERVICES; FILM DEVELOPING; BOOK BINDING AND DOCUMENT BINDING; DEVELOPMENT AND ENLARGEMENT OF PHOTOGRAPHIC FILM; PASSPORT PHOTOGRAPH DEVELOPING; ELECTRONIC ALTERATION AND RETOUCHING OF PHOTOGRAPHIC IMAGES, ARTWORK, PAINTINGS AND MEMENTOS; PRINTING (U.S. CLS. 100, 103 AND 106).

CLASS 41—EDUCATION AND ENTERTAINMENT

FOR DIGITAL IMAGING SERVICES, NAMELY, PHOTOGRAPHY (U.S. CLS. 100, 101 AND 107).

CLASS 42—SCIENTIFIC AND COMPUTER SERVICES

FOR LEASE AND RENTAL OF COMPUTERS, COMPUTER PERIPHERALS AND COMPUTER APPLICATION PROGRAMS; ELECTRONIC SCANNING AND DIGITIZING OF PHOTOGRAPHIC IMAGES, ARTWORK, PAINTINGS AND MEMENTOS (U.S. CLS. 100 AND 101).

ELISSA GARBER KON, EXAMINING ATTORNEY

SN 85-314,078. THE BOPPY COMPANY, LLC, GOLDEN, CO. FILED 5-6-2011.

BOPPY NATURALLY

THE MARK CONSISTS OF STANDARD CHARACTERS WITHOUT CLAIM TO ANY PARTICULAR FONT, STYLE, SIZE, OR COLOR.

OWNER OF U.S. REG. NOS. 1,919,783, 3,278,030 AND OTHERS.

CLASS 20—FURNITURE AND ARTICLES NOT OTHERWISE CLASSIFIED

FOR PILLOWS USED FOR CRADLING, SUPPORTING AND PROPPING BABIES (U.S. CLS. 2, 13, 22, 25, 32 AND 50).

CLASS 24—FABRICS

FOR FABRIC COVERS FOR PILLOWS (U.S. CLS. 42 AND 50).
ERNEST SHOSHO, EXAMINING ATTORNEY

SN 85-314,462. WEBCETERA, L.P., FLOWER MOUND, TX. FILED 5-6-2011.

CPPRO

THE MARK CONSISTS OF STANDARD CHARACTERS WITHOUT CLAIM TO ANY PARTICULAR FONT, STYLE, SIZE, OR COLOR.

CLASS 9—ELECTRICAL AND SCIENTIFIC APPARATUS

FOR COMPUTER SOFTWARE, NAMELY, COMPUTER SOFTWARE FOR PROVIDING A WEB-BASED PORTAL TO PROVIDE INSURANCE AGENTS AND BROKERS QUOTE INFORMATION (U.S. CLS. 21, 23, 26, 36 AND 38).

CLASS 36—INSURANCE AND FINANCIAL

FOR ONLINE INSURANCE-RELATED SERVICES, NAMELY, PROVIDING A WEB-BASED PORTAL TO PROVIDE INSURANCE AGENTS AND BROKERS QUOTE INFORMATION (U.S. CLS. 100, 101 AND 102).
JOHN WILKE, EXAMINING ATTORNEY

SN 85-314,981. CLUSTERCORP, INC., LA JOLLA, CA. FILED 5-6-2011.

STACKIQ

THE MARK CONSISTS OF STANDARD CHARACTERS WITHOUT CLAIM TO ANY PARTICULAR FONT, STYLE, SIZE, OR COLOR.

CLASS 9—ELECTRICAL AND SCIENTIFIC APPARATUS

FOR COMPUTER SOFTWARE FOR MULTISERVER AND CLUSTER MANAGEMENT, USED BY DATA CENTER SYSTEM ADMINISTRATORS; COMPUTER SOFTWARE, NAMELY, MANAGEMENT SOFTWARE FOCUSED ON THE DESIGN, DEVELOPMENT, PROVISIONING, CONFIGURATION, AND CHANGE MANAGEMENT OF LOCAL AND REMOTE DATA CENTER INFRASTRUCTURE ON PHYSICAL AND VIRTUAL MACHINES, AND PHYSICAL AND VIRTUAL NETWORKS (U.S. CLS. 21, 23, 26, 36 AND 38).

CLASS 42—SCIENTIFIC AND COMPUTER SERVICES

FOR SOFTWARE AS A SERVICE (SAAS) SERVICES FOR MULTISERVER AND CLUSTER MANAGEMENT, USED BY DATA CENTER SYSTEM ADMINISTRATORS; SOFTWARE AS A SERVICE (SAAS) SERVICES FEATURING MANAGEMENT SOFTWARE FOCUSED ON THE DESIGN, DEVELOPMENT, PROVISIONING, CONFIGURATION, AND CHANGE MANAGEMENT OF LOCAL AND REMOTE DATA CENTER INFRASTRUCTURE ON PHYSICAL AND VIRTUAL MACHINES, AND PHYSICAL AND VIRTUAL NETWORKS (U.S. CLS. 100 AND 101).

JAMES GRIFFIN, EXAMINING ATTORNEY

SN 85-314,985. CLUSTERCORP, INC., LA JOLLA, CA. FILED 5-6-2011.

STACK IQ

THE MARK CONSISTS OF STANDARD CHARACTERS WITHOUT CLAIM TO ANY PARTICULAR FONT, STYLE, SIZE, OR COLOR.

CLASS 9—ELECTRICAL AND SCIENTIFIC APPARATUS

FOR COMPUTER SOFTWARE FOR MULTISERVER AND CLUSTER MANAGEMENT, USED BY DATA CENTER SYSTEM ADMINISTRATORS; COMPUTER SOFTWARE, NAMELY, MANAGEMENT SOFTWARE FOCUSED ON THE DESIGN, DEVELOPMENT, PROVISIONING, CONFIGURATION, AND CHANGE MANAGEMENT OF LOCAL AND REMOTE DATA CENTER INFRASTRUCTURE ON PHYSICAL AND VIRTUAL MACHINES, AND PHYSICAL AND VIRTUAL NETWORKS (U.S. CLS. 21, 23, 26, 36 AND 38).

CLASS 42—SCIENTIFIC AND COMPUTER SERVICES

FOR SOFTWARE AS A SERVICE (SAAS) SERVICES FOR MULTISERVER AND CLUSTER MANAGEMENT, USED BY DATA CENTER SYSTEM ADMINISTRATORS; SOFTWARE AS A SERVICE (SAAS) SERVICES FEATURING MANAGEMENT SOFTWARE FOCUSED ON THE DESIGN, DEVELOPMENT, PROVISIONING, CONFIGURATION, AND CHANGE MANAGEMENT OF LOCAL AND REMOTE DATA CENTER INFRASTRUCTURE ON PHYSICAL AND VIRTUAL MACHINES, AND PHYSICAL AND VIRTUAL NETWORKS (U.S. CLS. 100 AND 101).

JAMES GRIFFIN, EXAMINING ATTORNEY

SN 85-315,397. ASPLUNDH INVESTMENTS, INC., WILMINGTON, DE. FILED 5-9-2011.

GRID ONE SOLUTIONS

THE MARK CONSISTS OF STANDARD CHARACTERS WITHOUT CLAIM TO ANY PARTICULAR FONT, STYLE, SIZE, OR COLOR.

NO CLAIM IS MADE TO THE EXCLUSIVE RIGHT TO USE "SOLUTIONS", APART FROM THE MARK AS SHOWN.

CLASS 35—ADVERTISING AND BUSINESS

FOR MANAGEMENT OF CALL CENTERS FOR OTHERS (U.S. CLS. 100, 101 AND 102).

CLASS 37—CONSTRUCTION AND REPAIR

FOR AUTOMATIC METER INSTALLATION SERVICES AND PROJECT MANAGEMENT RELATED THERETO; METER RETROFITTING SERVICES (U.S. CLS. 100, 103 AND 106).

CLASS 42—SCIENTIFIC AND COMPUTER SERVICES

FOR RESIDENTIAL, COMMERCIAL, AND INDUSTRIAL UTILITY METER SERVICES, NAMELY, ELECTRIC, GAS AND WATER METER READING SERVICES (U.S. CLS. 100 AND 101).

NICHOLAS ALTREE, EXAMINING ATTORNEY

SN 85-315,984. INTELLISPHERE, LLC, PLAINSBORO, NJ. FILED 5-9-2011.

PEERS & PERSPECTIVES

THE MARK CONSISTS OF STANDARD CHARACTERS WITHOUT CLAIM TO ANY PARTICULAR FONT, STYLE, SIZE, OR COLOR.

CLASS 9—ELECTRICAL AND SCIENTIFIC APPARATUS

FOR ELECTRONIC DOWNLOADABLE PUBLICATIONS, NAMELY, MAGAZINES IN THE FIELDS OF MEDICINE, HEALTH CARE, AND THE MEDICAL COMMUNITY (U.S. CLS. 21, 23, 26, 36 AND 38).

CLASS 16—PAPER GOODS AND PRINTED MATTER

FOR PRINTED PUBLICATIONS, NAMELY, A MAGAZINE IN THE FIELDS OF MEDICINE, HEALTH CARE, AND THE MEDICAL COMMUNITY (U.S. CLS. 2, 5, 22, 23, 29, 37, 38 AND 50).

CLASS 41—EDUCATION AND ENTERTAINMENT

FOR NON-DOWNLOADABLE ELECTRONIC PUBLICATIONS IN THE NATURE OF MAGAZINES IN THE FIELD OF MEDICINE, HEALTH CARE, AND THE MEDICAL COMMUNITY (U.S. CLS. 100, 101 AND 107).
MARC LEIPZIG, EXAMINING ATTORNEY

SN 85-318,981. THE READER'S DIGEST ASSOCIATION, INC., WHITE PLAINS, NY. FILED 5-12-2011.

AROOKOO

THE MARK CONSISTS OF STANDARD CHARACTERS WITHOUT CLAIM TO ANY PARTICULAR FONT, STYLE, SIZE, OR COLOR.

THE WORDING "AROOKOO" HAS NO MEANING IN A FOREIGN LANGUAGE.

CLASS 9—ELECTRICAL AND SCIENTIFIC APPARATUS

FOR DOWNLOADABLE COMPUTER GAME SOFTWARE VIA A GLOBAL COMPUTER NETWORK AND WIRELESS DEVICES (U.S. CLS. 21, 23, 26, 36 AND 38).

CLASS 41—EDUCATION AND ENTERTAINMENT

FOR ENTERTAINMENT SERVICES, NAMELY, PROVIDING ON-LINE COMPUTER GAMES; PROVIDING A WEBSITE FEATURING INFORMATION ON EXERCISE AND FITNESS (U.S. CLS. 100, 101 AND 107).

THEODORE MCBRIDE, EXAMINING ATTORNEY

SN 85-319,306. VITAL PHARMACEUTICALS, INC., WESTON, FL. FILED 5-12-2011.

STRATOSFEAR

THE MARK CONSISTS OF STANDARD CHARACTERS WITHOUT CLAIM TO ANY PARTICULAR FONT, STYLE, SIZE, OR COLOR.

CLASS 5—PHARMACEUTICALS

FOR DIETARY AND NUTRITIONAL SUPPLEMENTS (U.S. CLS. 6, 18, 44, 46, 51 AND 52).

CLASS 32—LIGHT BEVERAGES

FOR ENERGY DRINKS; ISOTONIC DRINKS; SPORTS DRINKS (U.S. CLS. 45, 46 AND 48).

TARA PATE, EXAMINING ATTORNEY

SN 85-320,279. DELCATH SYSTEMS, INC., NEW YORK, NY. FILED 5-13-2011.

ITENZIF

THE MARK CONSISTS OF STANDARD CHARACTERS WITHOUT CLAIM TO ANY PARTICULAR FONT, STYLE, SIZE, OR COLOR.

CLASS 5—PHARMACEUTICALS

FOR PHARMACEUTICAL PRODUCTS FOR THE TREATMENT OF CANCER (U.S. CLS. 6, 18, 44, 46, 51 AND 52).

CLASS 42—SCIENTIFIC AND COMPUTER SERVICES

FOR MEDICAL RESEARCH SERVICES IN THE FIELD OF CANCER (U.S. CLS. 100 AND 101).

JOSETTE BEVERLY, EXAMINING ATTORNEY

SN 85-321,795. ASSOCIATION OF BLACK CARDIOLOGISTS, ATLANTA, GA. FILED 5-16-2011.

TUNED2HEALTH

THE MARK CONSISTS OF STANDARD CHARACTERS WITHOUT CLAIM TO ANY PARTICULAR FONT, STYLE, SIZE, OR COLOR.

CLASS 41—EDUCATION AND ENTERTAINMENT

FOR EDUCATIONAL AND ENTERTAINMENT SERVICES, NAMELY, ONGOING RADIO SHOWS IN THE FIELD OF PERSONAL HEALTH; CONTINUING PUBLIC SERVICE PROGRAMS IN THE FIELD OF PERSONAL HEALTH PRODUCED AND DISTRIBUTED OVER RADIO, TELEVISION, SATELLITE, AUDIO, VIDEO, AND INTERNET MEDIA (U.S. CLS. 100, 101 AND 107).

CLASS 44—MEDICAL, BEAUTY AND AGRICULTURAL SERVICES

FOR PROVIDING A WEBSITE FEATURING NEWS AND INFORMATION IN THE FIELD OF GENERAL HEALTH TOPICS; PROVIDING HEALTH INFORMATION (U.S. CLS. 100 AND 101).

FIRST USE 5-13-2011; IN COMMERCE 5-13-2011.
MARK SPARACINO, EXAMINING ATTORNEY

SN 85-323,548. FEDERAL EXPRESS CORPORATION, MEMPHIS, TN. FILED 5-18-2011.

FEDEX SOLUTIONS FOR A SUSTAINABLE WORLD

THE MARK CONSISTS OF STANDARD CHARACTERS WITHOUT CLAIM TO ANY PARTICULAR FONT, STYLE, SIZE, OR COLOR.

OWNER OF U.S. REG. NOS. 1,311,503, 3,413,407 AND OTHERS.

CLASS 9—ELECTRICAL AND SCIENTIFIC APPARATUS

FOR DOWNLOADABLE SOFTWARE FOR USE IN ORDERING, PRINTING, BINDING AND SHIPPING SERVICES (U.S. CLS. 21, 23, 26, 36 AND 38).

CLASS 35—ADVERTISING AND BUSINESS

FOR ADVERTISING AND BUSINESS SERVICES, NAMELY, PHOTOCOPYING SERVICES; WORD-PROCESSING AND TYPING SERVICES; RENTAL OF OFFICE MACHINERY AND EQUIPMENT; PHOTOCOPYING AND REPRODUCING AND COMPILING DOCUMENTS FOR OTHERS; PREPARING PUBLI-CITY DOCUMENTS FOR OTHERS; LEASE AND RENTAL OF COPY MACHINES, TYPEWRITERS AND WORD PROCESSORS (U.S. CLS. 100, 101 AND 102).

CLASS 38—COMMUNICATION

FOR COMMUNICATION SERVICES, NAMELY, ELECTRONIC MAIL SERVICES AND ELECTRONIC TRANSMISSION OF DATA AND DOCUMENTS VIA COMPUTER TERMINALS; FACSIMILE TRANSMISSION SERVICES; RENTAL OF TELEPHONE, FACSIMILE AND VIDEO TELECONFERENCING EQUIPMENT (U.S. CLS. 100, 101 AND 104).

CLASS 39—TRANSPORTATION AND STORAGE

FOR PICK-UP, WAREHOUSING, TRANSPORTATION AND DELIVERY OF DOCUMENTS, PACKAGES AND FREIGHT BY LAND AND AIR (U.S. CLS. 100 AND 105).

CLASS 40—MATERIAL TREATMENT

FOR TREATMENT OF MATERIALS, NAMELY, THE LAMINATING AND COLLATING OF DOCUMENTS, PHOTOGRAPHS, SIGNS, BANNERS, AND CERTIFICATES; ASSEMBLING OF DOCUMENTS; PHOTOGRAPHIC REPRODUCTION SERVICES; FILM DEVELOPING; BOOK BINDING AND DOCUMENT BINDING; DEVELOPMENT AND ENLARGEMENT OF PHOTOGRAPHIC FILM; PASSPORT PHOTOGRAPH DEVELOPING; ELECTRONIC ALTERATION AND RETOUCHING OF PHOTOGRAPHIC IMAGES, ARTWORK, PAINTINGS AND MEMENTOS; PRINTING (U.S. CLS. 100, 103 AND 106).

CLASS 41—EDUCATION AND ENTERTAINMENT

FOR DIGITAL IMAGING SERVICES, NAMELY, PHOTOGRAPHY (U.S. CLS. 100, 101 AND 107).

CLASS 42—SCIENTIFIC AND COMPUTER SERVICES

FOR LEASE AND RENTAL OF COMPUTERS, COMPUTER PERIPHERALS AND COMPUTER APPLICATION PROGRAMS; ELECTRONIC SCANNING AND DIGITIZING OF PHOTOGRAPHIC IMAGES, ARTWORK, PAINTINGS AND MEMENTOS (U.S. CLS. 100 AND 101).

ELISSA GARBER KON, EXAMINING ATTORNEY

SN 85-324,837. RENMATIX, INC., KENNESAW, GA. FILED
5-19-2011.

SN 85-324,871. RENMATIX, INC., KENNESAW, GA. FILED
5-19-2011.



THE MARK CONSISTS OF AN OUTLINE OF A LEAF SUPERIMPOSED OVER A SWIRL DESIGN.

CLASS 1—CHEMICALS

FOR CHEMICALS FOR USE IN THE BIOCHEMICAL AND CHEMICAL INDUSTRY; CHEMICALS FOR USE IN THE MANUFACTURE OF A WIDE VARIETY OF GOODS; UNPROCESSED PLASTICS IN ALL FORMS (U.S. CLS. 1, 5, 6, 10, 26 AND 46).

CLASS 4—LUBRICANTS AND FUELS

FOR BIOFUELS (U.S. CLS. 1, 6 AND 15).

CLASS 20—FURNITURE AND ARTICLES NOT OTHERWISE CLASSIFIED

FOR PACKAGING CONTAINERS OF PLASTIC (U.S. CLS. 2, 13, 22, 25, 32 AND 50).

CLASS 21—HOUSEWARES AND GLASS

FOR BOTTLES, SOLD EMPTY (U.S. CLS. 2, 13, 23, 29, 30, 33, 40 AND 50).

CLASS 30—STAPLE FOODS

FOR SUGAR AND SUGAR SUBSTITUTES (U.S. CL. 46).
LINDSEY RUBIN, EXAMINING ATTORNEY



THE MARK CONSISTS OF A DISSOLVING LEAF SUPERIMPOSED OVER A DROPLET.

CLASS 1—CHEMICALS

FOR CHEMICALS FOR USE IN THE BIOCHEMICAL AND CHEMICAL INDUSTRY; CHEMICALS FOR USE IN THE MANUFACTURE OF A WIDE VARIETY OF GOODS; UNPROCESSED PLASTICS IN ALL FORMS (U.S. CLS. 1, 5, 6, 10, 26 AND 46).

CLASS 4—LUBRICANTS AND FUELS

FOR BIOFUELS (U.S. CLS. 1, 6 AND 15).

CLASS 20—FURNITURE AND ARTICLES NOT OTHERWISE CLASSIFIED

FOR PACKAGING CONTAINERS OF PLASTIC (U.S. CLS. 2, 13, 22, 25, 32 AND 50).

CLASS 21—HOUSEWARES AND GLASS

FOR BOTTLES, SOLD EMPTY (U.S. CLS. 2, 13, 23, 29, 30, 33, 40 AND 50).

CLASS 30—STAPLE FOODS

FOR SUGAR AND SUGAR SUBSTITUTES (U.S. CL. 46).

CLASS 40—MATERIAL TREATMENT

FOR CONTRACT MANUFACTURING IN THE FIELD OF BIOFUELS AND BIOCHEMICALS (U.S. CLS. 100, 103 AND 106).

CLASS 45—PERSONAL AND LEGAL SERVICES

FOR LICENSING OF TECHNOLOGY FOR THE MANUFACTURE OF BIOFUELS AND BIOCHEMICALS (U.S. CLS. 100 AND 101).
LINDSEY RUBIN, EXAMINING ATTORNEY

SN 85-324,903. RENMATIX, INC., KENNESAW, GA. FILED 5-19-2011.



THE MARK CONSISTS OF AN ARCHED BRIDGE WITH A REFLECTION THEREOF UNDERNEATH.

CLASS 1—CHEMICALS

FOR CHEMICALS FOR USE IN THE BIOCHEMICAL AND CHEMICAL INDUSTRY; CHEMICALS FOR USE IN THE MANUFACTURE OF A WIDE VARIETY OF GOODS; UNPROCESSED PLASTICS IN ALL FORMS (U.S. CLS. 1, 5, 6, 10, 26 AND 46).

CLASS 4—LUBRICANTS AND FUELS

FOR BIOFUELS (U.S. CLS. 1, 6 AND 15).
LINDSEY RUBIN, EXAMINING ATTORNEY

SN 85-325,436. BLANCO BASURA BEVERAGE, INC., SANTA CRUZ, CA. FILED 5-19-2011.

Chill Shoot Chase

THE MARK CONSISTS OF STANDARD CHARACTERS WITHOUT CLAIM TO ANY PARTICULAR FONT, STYLE, SIZE, OR COLOR.

CLASS 32—LIGHT BEVERAGES

FOR BEER (U.S. CLS. 45, 46 AND 48).

CLASS 33—WINES AND SPIRITS

FOR ALCOHOLIC BEVERAGES EXCEPT BEERS (U.S. CLS. 47 AND 49).
ODESSA BIBBINS, EXAMINING ATTORNEY

SN 85-325,937. FOREST LABORATORIES, INC., NEW YORK, NY. FILED 5-20-2011.



THE MARK CONSISTS OF THE WORD "VIIBRYD" WITH A SWIRL ABOVE THE WORD WITH A DOT IN THE SWIRL ABOVE THE LETTER "Y".

CLASS 16—PAPER GOODS AND PRINTED MATTER

FOR PRINTED MATTER, NAMELY, BROCHURES, PAMPHLETS, POSTERS, NEWSLETTERS, VISUALS IN THE NATURE OF PROMOTIONAL MATERIALS, AND PATIENT EDUCATIONAL MATERIALS, ALL CONCERNING THE TREATMENT OF DEPRESSION (U.S. CLS. 2, 5, 22, 23, 29, 37, 38 AND 50).

CLASS 44—MEDICAL, BEAUTY AND AGRICULTURAL SERVICES

FOR MEDICAL INFORMATION SERVICES, NAMELY, PROVIDING HEALTH INFORMATION IN THE FIELD OF DEPRESSION VIA A GLOBAL COMPUTER NETWORK (U.S. CLS. 100 AND 101).

MICHAEL WEBSTER, EXAMINING ATTORNEY

SN 85-326,085. FOREST LABORATORIES, INC., NEW YORK, NY. FILED 5-20-2011.



THE MARK CONSISTS OF A SWIRL WITH A DOT IN THE MIDDLE OF THE SWIRL.

CLASS 16—PAPER GOODS AND PRINTED MATTER

FOR PRINTED MATTER, NAMELY, BROCHURES, PAMPHLETS, POSTERS, NEWSLETTERS, VISUALS IN THE NATURE OF PROMOTIONAL MATERIALS, AND PATIENT EDUCATIONAL MATERIALS, ALL CONCERNING THE TREATMENT OF DEPRESSION (U.S. CLS. 2, 5, 22, 23, 29, 37, 38 AND 50).

CLASS 44—MEDICAL, BEAUTY AND AGRICULTURAL SERVICES

FOR MEDICAL INFORMATION SERVICES, NAMELY, PROVIDING HEALTH INFORMATION IN THE FIELD OF DEPRESSION VIA A GLOBAL COMPUTER NETWORK (U.S. CLS. 100 AND 101).

MICHAEL WEBSTER, EXAMINING ATTORNEY

SN 85-327,818. IGLOO PRODUCTS CORP., KATY, TX. FILED 5-23-2011.



OWNER OF U.S. REG. NOS. 718,413, 961,185 AND 3,454,203.

NO CLAIM IS MADE TO THE EXCLUSIVE RIGHT TO USE "OUTDOORS", APART FROM THE MARK AS SHOWN. THE MARK CONSISTS OF A STYLIZED IMAGE OF AN UNSHADED TREE, BRANCHES AND LEAVES, ON A PARTIALLY SHADED BACKGROUND, WITH A STYLIZED IGLOO HOUSE TO THE RIGHT, CONSISTING OF A HALF CIRCLE AND TWO ARCHES, ONE SHADED AND ONE UNSHADED EXTENDING OUT FROM THE HALF CIRCLE, WITH THE WORDING, "IGLOO" INSIDE A RECTANGLE WITH ONE CURVED CORNER BELOW, AND WITH THE WORDING, "OUTDOORS" INSIDE A RECTANGLE, BELOW "IGLOO".

CLASS 18—LEATHER GOODS

FOR BACKPACKS (U.S. CLS. 1, 2, 3, 22 AND 41).

CLASS 20—FURNITURE AND ARTICLES NOT OTHERWISE CLASSIFIED

FOR CUSHIONS; OUTDOOR FURNITURE; SLEEPING BAG PADS; SLEEPING BAGS (U.S. CLS. 2, 13, 22, 25, 32 AND 50).

CLASS 22—CORDAGE AND FIBERS

FOR TENTS; TENTS FOR MOUNTAINEERING OR CAMPING (U.S. CLS. 1, 2, 7, 19, 22, 42 AND 50).
ODESSA BIBBINS, EXAMINING ATTORNEY

SN 85-327,869. WD-40 MANUFACTURING COMPANY, SAN DIEGO, CA. FILED 5-23-2011.

WD-40 NO-RUST SHIELD

THE MARK CONSISTS OF STANDARD CHARACTERS WITHOUT CLAIM TO ANY PARTICULAR FONT, STYLE, SIZE, OR COLOR.

OWNER OF U.S. REG. NOS. 3,604,438 AND 3,845,676.
NO CLAIM IS MADE TO THE EXCLUSIVE RIGHT TO USE "NO-RUST", APART FROM THE MARK AS SHOWN.

CLASS 2—PAINTS

FOR PROTECTIVE COATINGS FOR RUST PREVENTION AND CORROSION CONTROL (U.S. CLS. 6, 11 AND 16).

CLASS 4—LUBRICANTS AND FUELS

FOR ALL-PURPOSE PENETRATING AND LUBRICATING OIL (U.S. CLS. 1, 6 AND 15).
NAPOLEON SHARMA, EXAMINING ATTORNEY

SN 85-328,041. CHELSEA & SCOTT, LTD, LAKE BLUFF, IL. FILED 5-23-2011.

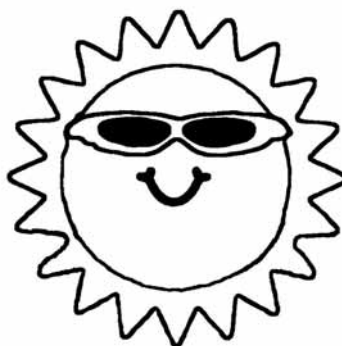

THE MARK CONSISTS OF A FANCIFUL SUN FACE WEARING SUNGLASSES AND A SMILE.

CLASS 12—VEHICLES

FOR UMBRELLAS TO BE AFFIXED TO BABY STROLLER (U.S. CLS. 19, 21, 23, 31, 35 AND 44).
FIRST USE 2-28-2006; IN COMMERCE 2-28-2006.

CLASS 18—LEATHER GOODS

FOR BEACH BAGS; BEACH UMBRELLAS; PARASOLS; UMBRELLAS FOR CHILDREN (U.S. CLS. 1, 2, 3, 22 AND 41).
FIRST USE 2-22-2011; IN COMMERCE 2-22-2011.

CLASS 22—CORDAGE AND FIBERS

FOR FABRIC CABANAS; TENTS (U.S. CLS. 1, 2, 7, 19, 22, 42 AND 50).
FIRST USE 2-22-2011; IN COMMERCE 2-22-2011.

CLASS 25—CLOTHING

FOR CLOTH DIAPERS; FOOTWEAR; HATS; ONE-PIECE GARMENTS FOR CHILDREN; ROMPERS; SHIRTS; SHORTS; SOCKS; SWIMSUITS; T-SHIRTS; TANK-TOPS (U.S. CLS. 22 AND 39).
FIRST USE 2-28-2006; IN COMMERCE 2-28-2006.
SETH A. RAPPAPORT, EXAMINING ATTORNEY

SN 85-332,600. PAKULA, KEN, CHICAGO, IL. FILED 5-27-2011.

POLITICIAN UNIVERSITY

THE MARK CONSISTS OF STANDARD CHARACTERS WITHOUT CLAIM TO ANY PARTICULAR FONT, STYLE, SIZE, OR COLOR.

CLASS 14—JEWELRY

FOR JEWELRY (U.S. CLS. 2, 27, 28 AND 50).

SN 85-339,374. NEXON AMERICA INC., EL SEGUNDO, CA.
FILED 6-6-2011.**CLASS 16—PAPER GOODS AND PRINTED MATTER**

FOR BUMPER STICKERS; BUSINESS CARDS; PENS; PRINTED CERTIFICATES (U.S. CLS. 2, 5, 22, 23, 29, 37, 38 AND 50).

CLASS 25—CLOTHING

FOR HATS; SHIRTS (U.S. CLS. 22 AND 39).

CLASS 28—TOYS AND SPORTING GOODSFOR STUFFED TOY ANIMALS (U.S. CLS. 22, 23, 38 AND 50).
ERIN FALK, EXAMINING ATTORNEY**WONDER CRUISE**SN 85-337,090. LEITERMAN AND ASSOCIATES, INC.,
SPOONER, WI. FILED 6-3-2011.**THE NATURAL CHOICE FOR
AGRICULTURE**THE MARK CONSISTS OF STANDARD CHARACTERS
WITHOUT CLAIM TO ANY PARTICULAR FONT, STYLE,
SIZE, OR COLOR.

OWNER OF U.S. REG. NO. 3,381,936.

THE MARK CONSISTS OF STANDARD CHARACTERS
WITHOUT CLAIM TO ANY PARTICULAR FONT, STYLE,
SIZE, OR COLOR.**CLASS 3—COSMETICS AND CLEANING PREPARATIONS**

FOR TOPICAL HEALTH AIDS FOR LIVESTOCK, NAMELY, NON-MEDICATED SALVES IN THE NATURE OF NON-MEDICATED MOISTURIZING CREAMS AND NON-MEDICATED SKIN CREAMS (U.S. CLS. 1, 4, 6, 50, 51 AND 52).

FIRST USE 8-28-1998; IN COMMERCE 8-31-1998.

CLASS 9—ELECTRICAL AND SCIENTIFIC APPARATUS

FOR COMPUTER GAME SOFTWARE; COMPUTER SOFTWARE PROGRAMS FOR THE INTEGRATION OF TEXT, AUDIO, GRAPHICS, STILL IMAGES AND MOVING PICTURES INTO AN INTERACTIVE DELIVERY FOR MULTIMEDIA APPLICATIONS; COMPUTER APPLICATION SOFTWARE FOR MOBILE PHONES, NAMELY, SOFTWARE FOR INTERACTIVE ONLINE GAMES AND INTERACTIVE ONLINE SOCIAL NETWORKING; VIDEO GAME PROGRAMS AND INTERACTIVE VIDEO GAME PROGRAMS; COMPUTER SOFTWARE PLATFORMS FOR SOCIAL NETWORKING; DOWNLOADABLE ELECTRONIC GAME PROGRAMS AND COMPUTER SOFTWARE PLATFORMS FOR SOCIAL NETWORKING THAT MAY BE ACCESSED VIA THE INTERNET, COMPUTERS AND WIRELESS DEVICES; COMPUTER SOFTWARE TO ENABLE UPLOADING, POSTING, SHOWING, DISPLAYING, TAGGING, BLOGGING, SHARING OR OTHERWISE PROVIDING ELECTRONIC MEDIA OR INFORMATION IN THE FIELDS OF VIRTUAL COMMUNITIES, ELECTRONIC GAMES, ENTERTAINMENT AND GENERAL INTEREST VIA THE INTERNET OR OTHER COMMUNICATIONS NETWORKS WITH THIRD PARTIES; MAGNETIC CODED GIFT CARDS (U.S. CLS. 21, 23, 26, 36 AND 38).

CLASS 5—PHARMACEUTICALS

FOR NUTRITIONAL SUPPLEMENTS FOR ALL LIVESTOCK, NAMELY, COWS, CALVES, SWINE, POULTRY, GOATS, SHEEP, HORSES, COMPANION ANIMALS AND EXOTIC ANIMALS; TOPICAL HEALTH AIDS FOR LIVESTOCK, NAMELY, LINIMENTS AND FLY REPELLENT (U.S. CLS. 6, 18, 44, 46, 51 AND 52).

FIRST USE 8-28-1998; IN COMMERCE 8-31-1998.

CLASS 44—MEDICAL, BEAUTY AND AGRICULTURAL SERVICES

FOR CONSULTING SERVICES IN THE FIELDS OF HEALTH AND NUTRITION FOR LIVESTOCK; PROVIDING HEALTH INFORMATION REGARDING LIVESTOCK; PROVIDING NUTRITIONAL INFORMATION REGARDING LIVESTOCK; PROVIDING INFORMATION ABOUT ANIMAL HUSBANDRY REGARDING LIVESTOCK; PROVIDING HEALTHCARE INFORMATION REGARDING THE USE OF NUTRITIONAL SUPPLEMENTS AND TOPICAL HEALTH AIDS USED ON LIVESTOCK (U.S. CLS. 100 AND 101).

FIRST USE 8-28-1998; IN COMMERCE 8-31-1998.
MICHAEL TANNER, EXAMINING ATTORNEY**CLASS 41—EDUCATION AND ENTERTAINMENT**

FOR ONLINE COMPUTER AND ELECTRONIC GAMES AND ENHANCEMENTS WITHIN ONLINE COMPUTER AND ELECTRONIC GAMES; GAME APPLICATIONS WITHIN ONLINE COMPUTER AND ELECTRONIC GAMES; AND VIRTUAL ENVIRONMENTS IN WHICH USERS INTERACT THROUGH SOCIAL GAMES, FOR RECREATIONAL, LEISURE OR ENTERTAINMENT PURPOSES (U.S. CLS. 100, 101 AND 107).

MICHAEL SOUDERS, EXAMINING ATTORNEY

SN 85-341,126. VONAGE MARKETING LLC, HOLMDEL, NJ.
FILED 6-8-2011.

SN 85-344,271. VITAMIN SHOPPE INDUSTRIES INC.,
NORTH BERGEN, NJ. FILED 6-13-2011.



OWNER OF U.S. REG. NOS. 2,614,773, 3,740,428 AND OTHERS.

THE MARK CONSISTS OF A TELEPHONE RECEIVER WITH A CONTINUOUS WAVE-LIKE DESIGN COMPRISED OF REPEATING DESIGNS OF A SOLID DOT INSIDE A STYLIZED "V", BOTH RIGHT SIDE UP AND UPSIDE DOWN EMANATING FROM EAR PIECE PORTION OF TELEPHONE RECEIVER OVER THE WORLD MAP WITH THE WORDS "VONAGE" UNDER THE TELEPHONE RECEIVER.

CLASS 9—ELECTRICAL AND SCIENTIFIC APPARATUS

FOR COMPUTER TELEPHONY SOFTWARE, NAMELY, SOFTWARE APPLICATIONS FOR ESTABLISHING AND PERFORMING PHONE CALLS, VIDEO CONFERENCING AND VIRTUAL VIDEO CONFERENCING OVER A VARIETY OF NETWORKS IN THE NATURE OF THE INTERNET; DOWNLOADABLE SOFTWARE FOR USE WITH WIRELESS TELECOMMUNICATIONS DEVICES TO PROVIDE WIRELESS TRANSMISSION OF E-MAIL, TEXT, MUSIC, VIDEO, VOICE, STILL IMAGES, INFORMATION, DATA, VIDEO CONFERENCING, VIRTUAL VIDEO CONFERENCING AND OTHER CONTENT VIA THE INTERNET AND VIA WIRELESS LOCAL AREA NETWORK DEVICES; COMPUTER AND TELECOMMUNICATIONS NETWORK HUBS, SWITCHES AND ROUTERS; COMPUTER HARDWARE AND COMMUNICATIONS SOFTWARE FOR USE IN CONNECTING TELECOMMUNICATIONS EQUIPMENT, TELEPHONES, COMPUTERS, WIRED AND WIRELESS COMPUTER NETWORKS; COMPUTER SOFTWARE AND HARDWARE FOR PROVIDING TRANSMISSION AND EXCHANGE OF VOICE, VIDEO, DATA, IMAGES AND GRAPHICS IN THE FIELDS OF TELECOMMUNICATIONS, VIDEO CONFERENCING AND VIRTUAL VIDEO CONFERENCING; HARDWARE FOR TELECOMMUNICATIONS FOR CONNECTING DEVICES VIA IN-HOME PHONE AND ELECTRICAL WIRING, NAMELY, COMPUTER NETWORK HUBS, COMPUTER SWITCHES AND COMPUTER ROUTERS DESIGNED TO PROVIDE IN-HOME VOICE OVER INTERNET PROTOCOL (VOIP) COMMUNICATIONS (U.S. CLS. 21, 23, 26, 36 AND 38).

CLASS 38—COMMUNICATION

FOR TELEPHONY COMMUNICATIONS SERVICES; TELECONFERENCING SERVICES; VIDEO CONFERENCING AND VIRTUAL VIDEO CONFERENCING SERVICES (U.S. CLS. 100, 101 AND 104).
VERNA BETH RIRIE, EXAMINING ATTORNEY

TRUE ATHLETE

THE MARK CONSISTS OF STANDARD CHARACTERS WITHOUT CLAIM TO ANY PARTICULAR FONT, STYLE, SIZE, OR COLOR.

NO CLAIM IS MADE TO THE EXCLUSIVE RIGHT TO USE "ATHLETE", APART FROM THE MARK AS SHOWN.

CLASS 18—LEATHER GOODS

FOR GYM BAGS, SPORT BAGS AND DUFFLE BAGS (U.S. CLS. 1, 2, 3, 22 AND 41).

CLASS 21—HOUSEWARES AND GLASS

FOR REUSABLE PLASTIC WATER BOTTLES SOLD EMPTY, SPORTS DRINK SHAKER PLASTIC BOTTLES FOR MIXING WATER AND NUTRITIONAL SUPPLEMENTS SOLD EMPTY; SQUEEZE BOTTLES SOLD EMPTY (U.S. CLS. 2, 13, 23, 29, 30, 33, 40 AND 50).

CLASS 28—TOYS AND SPORTING GOODS

FOR SPORTING GOODS, WEIGHT TRAINING AND EXERCISE EQUIPMENT, NAMELY, RESISTANCE BANDS TO ATTACH ON DOORS, RESISTANCE BANDS FOR INDIVIDUAL WORKOUTS, WAIST TRIMMER BELTS, JUMP ROPES, WEIGHT LIFTING GLOVES, RESISTANCE AND EXERCISE BALLS, CHIN-UP BARS AND PULL-UP BARS (U.S. CLS. 22, 23, 38 AND 50).
JAMES GRIFFIN, EXAMINING ATTORNEY

SN 85-357,192. KITTY LIKES TO SCRATCH PRODUCTIONS, INC., LOS ANGELES, CA. FILED 6-27-2011.

ORIGINAL B

THE MARK CONSISTS OF STANDARD CHARACTERS WITHOUT CLAIM TO ANY PARTICULAR FONT, STYLE, SIZE, OR COLOR.

CLASS 3—COSMETICS AND CLEANING PREPARATIONS

FOR COSMETICS, NAMELY, FRAGRANCES, PERFUMES, AND NON-MEDICATED FACE CARE PREPARATIONS (U.S. CLS. 1, 4, 6, 50, 51 AND 52).

CLASS 14—JEWELRY

FOR JEWELRY AND COSTUME JEWELRY, RINGS, BRACELETS, NECKLACES, TIE BARS, SCARF RINGS, PENDANTS, EAR CLIPS, TIE CLIPS, CUFF-LINKS OF PRECIOUS METAL, EARRINGS, KEY HOLDERS MADE OF PRECIOUS METALS, BROOCHES, LAPEL PINS, CLOCKS, WATCHES, CHRONOGRAPHS FOR USE AS WATCHES, CHRONOMETERS (U.S. CLS. 2, 27, 28 AND 50).

CLASS 18—LEATHER GOODS

FOR LEATHER AND IMITATION LEATHER GOODS, NAMELY, CASES, BAGS, WALLETS, BRIEF CASES, CREDIT CARD CASES, BUSINESS CARD CASES, CALLING CARD CASES, CARRYING CASES, DOCUMENT CASES, TRAVELING CASES, VANITY CASES SOLD EMPTY, CASES FOR KEYS, LEATHER FOR SHOES, HANDBAGS, LEATHER KEY CHAINS, PURSES, SPORTS BAGS, LEATHER SHOPPING BAGS, STRAPS, AND LUGGAGE; SUITCASES (U.S. CLS. 1, 2, 3, 22 AND 41).

CLASS 25—CLOTHING

FOR CLOTHING, NAMELY, BLOUSES, SHIRTS, SKIRTS, BLAZERS, LINGERIE, SKIRT SUITS, PANTS, SHORTS, DRESSES AND SHOES (U.S. CLS. 22 AND 39).
BRIDGETT SMITH, EXAMINING ATTORNEY

SN 85-357,945. SYNGENTA PARTICIPATIONS AG, BASEL, SWITZERLAND, FILED 6-28-2011.

Agador

THE MARK CONSISTS OF STANDARD CHARACTERS WITHOUT CLAIM TO ANY PARTICULAR FONT, STYLE, SIZE, OR COLOR.

CLASS 1—CHEMICALS

FOR CHEMICALS FOR USE IN AGRICULTURE, HORTICULTURE AND FORESTRY EXCEPT INSECTICIDES, PARASITICIDES, FUNGICIDES, AND HERBICIDES (U.S. CLS. 1, 5, 6, 10, 26 AND 46).

CLASS 5—PHARMACEUTICALS

FOR PESTICIDES, INSECTICIDES, NEMATICIDES, FUNGICIDES, HERBICIDES FOR AGRICULTURAL, DOMESTIC AND COMMERCIAL USE (U.S. CLS. 6, 18, 44, 46, 51 AND 52).

JOHN HWANG, EXAMINING ATTORNEY

SN 85-360,439. VONAGE MARKETING LLC, HOLMDEL, NJ, FILED 6-30-2011.

Vonage

OWNER OF U.S. REG. NOS. 2,614,773, 3,740,428 AND OTHERS.

THE MARK CONSISTS OF THE WORD "VONAGE" WITH A STYLIZED "V" WITH DOT.

CLASS 9—ELECTRICAL AND SCIENTIFIC APPARATUS

FOR (BASED ON INTENT TO USE) COMPUTER TELEPHONY SOFTWARE, NAMELY, SOFTWARE APPLICATIONS FOR ESTABLISHING AND PERFORMING PHONE CALLS, VIDEO CONFERENCING AND VIRTUAL VIDEO CONFERENCING OVER A VARIETY OF NETWORKS IN THE NATURE OF THE INTERNET; (BASED ON INTENT TO USE) COMPUTER SOFTWARE AND HARDWARE FOR PROVIDING TRANSMISSION AND EXCHANGE OF VOICE, VIDEO, DATA, IMAGES AND GRAPHICS IN THE FIELDS OF TELECOMMUNICATIONS, VIDEO CONFERENCING AND VIRTUAL VIDEO CONFERENCING; (BASED ON INTENT TO USE) DOWNLOADABLE SOFTWARE FOR USE WITH WIRELESS TELECOMMUNICATIONS DEVICES TO PROVIDE WIRELESS TRANSMISSION OF E-MAIL, TEXT, MUSIC, VIDEO, STILL IMAGES, INFORMATION, DATA, VIDEO CONFERENCING, VIRTUAL VIDEO CONFERENCING AND OTHER CONTENT VIA THE INTERNET AND VIA WIRELESS LOCAL AREA NETWORK DEVICES; (BASED ON FIRST USE IN COMMERCE AS OF 3/15/06) COMPUTER AND TELECOMMUNICATIONS NETWORK HUBS, SWITCHES AND ROUTERS; COMPUTER HARDWARE AND COMMUNICATIONS SOFTWARE FOR USE IN CONNECTING TELECOMMUNICATIONS EQUIPMENT, TELEPHONES, COMPUTERS, WIRED AND WIRELESS COMPUTER NETWORKS; (BASED ON FIRST USE IN COMMERCE AS OF 3/15/06) HARDWARE FOR TELECOMMUNICATIONS FOR CONNECTING DEVICES VIA IN-HOME PHONE AND ELECTRICAL WIRING, NAMELY, COMPUTER NETWORK HUBS, COMPUTER SWITCHES AND COMPUTER ROUTERS DESIGNED TO PROVIDE IN-HOME VOICE OVER INTERNET PROTOCOL (VOIP) COMMUNICATIONS; (BASED ON FIRST USE IN COMMERCE AS OF 10/5/2009) DOWNLOADABLE SOFTWARE FOR USE WITH WIRELESS TELECOMMUNICATIONS DEVICES TO PROVIDE WIRELESS TRANSMISSION OF VOICE AND OTHER CONTENT VIA THE INTERNET AND VIA WIRELESS LOCAL AREA NETWORK DEVICES (U.S. CLS. 21, 23, 26, 36 AND 38).

FIRST USE 3-15-2006; IN COMMERCE 3-15-2006.

CLASS 38—COMMUNICATION

FOR (BASED ON INTENT TO USE) TELECONFERENCING SERVICES; VIDEO CONFERENCING AND VIRTUAL VIDEO CONFERENCING SERVICES; (BASED ON FIRST USE IN COMMERCE AS OF 3/15/06) TELEPHONY COMMUNICATIONS SERVICES (U.S. CLS. 100, 101 AND 104).

FIRST USE 3-15-2006; IN COMMERCE 3-15-2006.
VERNA BETH RIRIE, EXAMINING ATTORNEY

SN 85-975,424. RECKITT BENCKISER LLC, PARSIPPANY, NJ, FILED 10-18-2010.

NO-TOUCH

THE MARK CONSISTS OF STANDARD CHARACTERS WITHOUT CLAIM TO ANY PARTICULAR FONT, STYLE, SIZE, OR COLOR.

CLASS 3—COSMETICS AND CLEANING PREPARATIONS

FOR ANTIBACTERIAL SOAPS; SOAPS FOR PERSONAL USE; HAND CLEANING PREPARATIONS; NON-MEDICATED HANDWASHES; LIQUID SOAPS FOR HANDS, FACE AND BODY; NON-MEDICATED SKIN CARE PREPARATIONS, NAMELY, BARRIER CREAMS, LOTIONS AND GELS (U.S. CLS. 1, 4, 6, 50, 51 AND 52).

FIRST USE 12-31-2009; IN COMMERCE 12-31-2009.

CLASS 5—PHARMACEUTICALS

WILLIAM ROSSMAN, EXAMINING ATTORNEY

FOR HAND SANITIZING PREPARATIONS; MEDICATED ANTIBACTERIAL SKIN CLEANSERS; ANTIBACTERIAL HAND WASH; ANTIBACTERIAL HAND LOTIONS, CREAMS AND GELS; ANTIBACTERIAL SKIN PROTECTION LOTIONS, CREAMS AND GELS (U.S. CLS. 6, 18, 44, 46, 51 AND 52).
FIRST USE 12-31-2009; IN COMMERCE 12-31-2009.

* * * * *

SECTION 2.— INTERNATIONAL CLASSIFICATION

The short titles associated below with the international class numbers are terms designed merely for quick identification and are not an official part of the international classification. The full names of international classes are given in section 6.1 of the trademark rules of practice.

The designation "U.S. Cl." appearing in this section refers to the U.S. class in effect prior to Sep. 1, 1973 rather than the international class which applies to applications filed on or after that date. For adoption of international classification see notice in the OFFICIAL GAZETTE of Jun. 26, 1973 (911 O.G. TM 210).

Application in one class

CLASS 1—CHEMICALS

SN 77-677,976. WEATHERFORD/LAMB, INC., HOUSTON, TX. FILED 2-25-2009.

ZETA FLOW

THE MARK CONSISTS OF STANDARD CHARACTERS WITHOUT CLAIM TO ANY PARTICULAR FONT, STYLE, SIZE, OR COLOR.

NO CLAIM IS MADE TO THE EXCLUSIVE RIGHT TO USE "FLOW", APART FROM THE MARK AS SHOWN.

FOR SYNTHETIC CONDUCTIVITY ENHANCER, FINES CONTROL AND LOAD RECOVERY AGENTS FOR USE IN OIL AND GAS RECOVERY FIELD; SYNTHETIC FLOWBACK PROPPANT CONTROL ADDITIVES FOR USE IN THE OIL AND GAS RECOVERY FIELD (U.S. CLS. 1, 5, 6, 10, 26 AND 46).

FIRST USE 11-1-2006; IN COMMERCE 11-1-2006.
FONG HSU, EXAMINING ATTORNEY

SN 78-801,369. DYNAMIC COSMETICS, INC., NEWTON, PA. FILED 1-27-2006.

NANOSPERSION

THE MARK CONSISTS OF STANDARD CHARACTERS WITHOUT CLAIM TO ANY PARTICULAR FONT, STYLE, SIZE, OR COLOR.

FOR CHEMICALS FOR USE IN THE MANUFACTURE OF COSMETIC, PERSONAL CARE AND PHARMACEUTICAL PRODUCTS (U.S. CLS. 1, 5, 6, 10, 26 AND 46).

FIRST USE 7-30-2000; IN COMMERCE 7-30-2000.
DEZMONA MIZELLE, EXAMINING ATTORNEY

CLASS 1—(Continued).

SN 79-086,042. JONGKIND GROND B.V., NETHERLANDS, FILED 5-25-2010.



PRIORITY DATE OF 11-27-2009 IS CLAIMED.

OWNER OF INTERNATIONAL REGISTRATION 1047558 DATED 5-25-2010, EXPIRES 5-25-2020.

THE MARK CONSISTS OF THE WORDING "GOLD LABEL" INSIDE AN OVAL DESIGN. A HUMAN SILHOUETTE WITH TWO HORIZONTAL LINES APPEAR ABOVE THE WORDING.

FOR CHEMICAL PREPARATIONS FOR USE IN AGRICULTURE, HORTICULTURE AND FORESTRY EXCEPT FUNGICIDES, HERBICIDES, INSECTICIDES AND PARASITICIDES; SOIL, NAMELY, POTTING SOIL, SOIL FOR PLANT CULTIVATION AND PLANTING SOIL; NATURAL MANURE AND ARTIFICIAL MANURE; COMPOST; HYDROGRANULES FOR PLANT GROWTH; NUTRIENTS FOR PLANTS (U.S. CLS. 1, 5, 6, 10, 26 AND 46).

EMILY CHUO, EXAMINING ATTORNEY

SN 79-088,381. COMPO GMBH & CO. KG, FED REP GERMANY, FILED 10-5-2010.

Fertilis speed

THE MARK CONSISTS OF STANDARD CHARACTERS WITHOUT CLAIM TO ANY PARTICULAR FONT, STYLE, SIZE, OR COLOR.

OWNER OF INTERNATIONAL REGISTRATION 1054033 DATED 10-5-2010, EXPIRES 10-5-2020.

THE ENGLISH TRANSLATION OF "FERTILIS" IN THE MARK IS "FRUITFUL", "FERTILE" OR "PRODUCTIVE".

FOR FERTILIZERS (U.S. CLS. 1, 5, 6, 10, 26 AND 46).
SANI KHOURI, EXAMINING ATTORNEY

CLASS 1—(Continued).

SN 79-088,453. TAZZETTI S.P.A., ITALY, FILED 9-16-2010.

REFRIX

THE MARK CONSISTS OF STANDARD CHARACTERS WITHOUT CLAIM TO ANY PARTICULAR FONT, STYLE, SIZE, OR COLOR.

PRIORITY DATE OF 8-6-2010 IS CLAIMED.

OWNER OF INTERNATIONAL REGISTRATION 1054239 DATED 9-16-2010, EXPIRES 9-16-2020.

FOR CHEMICALS USED IN INDUSTRY AND SCIENCE; CHEMICALS USED IN PHOTOGRAPHY, NAMELY, PHOTOGRAPHIC CHEMICALS; CHEMICALS USED IN AGRICULTURE, HORTICULTURE AND FORESTRY, EXCEPT FUNGICIDES, HERBICIDES, INSECTICIDES AND PARASITICIDES; UNPROCESSED ARTIFICIAL RESINS, UNPROCESSED PLASTICS IN ALL FORMS; MANURES; FIRE EXTINGUISHING COMPOSITIONS; TEMPERING AND SOLDERING PREPARATIONS, NAMELY, CHEMICALS; CHEMICAL SUBSTANCES FOR PRESERVING FOODSTUFFS; TANNING SUBSTANCES, NAMELY, TANNING AGENTS FOR USE IN THE MANUFACTURE OF LEATHER, ENZYMES FOR USE IN THE TANNING OF LEATHER; ADHESIVES USED IN INDUSTRY (U.S. CLS. 1, 5, 6, 10, 26 AND 46).

JESSICA FATHY, EXAMINING ATTORNEY

SN 79-088,999. SIKA AG, SWITZERLAND, FILED 9-20-2010.

SIKATITAN-P2G

THE MARK CONSISTS OF STANDARD CHARACTERS WITHOUT CLAIM TO ANY PARTICULAR FONT, STYLE, SIZE, OR COLOR.

PRIORITY DATE OF 8-4-2010 IS CLAIMED.

OWNER OF INTERNATIONAL REGISTRATION 1055706 DATED 9-20-2010, EXPIRES 9-20-2020.

OWNER OF U.S. REG. NOS. 1,578,445, 3,712,344 AND 3,734,507.

FOR ADHESIVES FOR INDUSTRIAL PURPOSES, NAMELY, ADHESIVES FOR REPAIRING MOTOR VEHICLES (U.S. CLS. 1, 5, 6, 10, 26 AND 46).

NATALIE POLZER, EXAMINING ATTORNEY

SN 79-089,424. COMPO GMBH & CO. KG, FED REP GERMANY, FILED 10-6-2010.

Fertilis Swing

THE MARK CONSISTS OF STANDARD CHARACTERS WITHOUT CLAIM TO ANY PARTICULAR FONT, STYLE, SIZE, OR COLOR.

OWNER OF INTERNATIONAL REGISTRATION 0994157 DATED 11-17-2008, EXPIRES 11-17-2018.

THE ENGLISH TRANSLATION OF "FERTILIS" IN THE MARK IS "FRUITFUL", "FERTILE" OR "PRODUCTIVE".

FOR CHEMICALS USED IN AGRICULTURE, HORTICULTURE AND FORESTRY, NAMELY, A GREEN FERTILIZER CONTAINING ROOT SUPPORTING MICROORGANISMS EXCEPT FUNGICIDES, HERBICIDES, INSECTICIDES AND PARASITICIDES; FERTILIZERS (U.S. CLS. 1, 5, 6, 10, 26 AND 46).

SANI KHOURI, EXAMINING ATTORNEY

CLASS 1—(Continued).

SN 79-090,143. DSM IP ASSETS B.V., NETHERLANDS, FILED 10-7-2010.

GUMZYME

THE MARK CONSISTS OF STANDARD CHARACTERS WITHOUT CLAIM TO ANY PARTICULAR FONT, STYLE, SIZE, OR COLOR.

PRIORITY DATE OF 5-7-2010 IS CLAIMED.

OWNER OF INTERNATIONAL REGISTRATION 1058750 DATED 10-7-2010, EXPIRES 10-7-2020.

FOR BIOCHEMICAL PRODUCTS FOR USE IN THE PRODUCTION OF FOOD, NAMELY, ENZYMES AND ENZYME PREPARATIONS FOR USE IN THE FOOD PROCESSING INDUSTRY; ENZYMES AND ENZYME PREPARATIONS TO BE USED AS PROCESSING AID IN VEGETABLE OILS; CLARIFICATION AGENTS FOR VEGETABLE OILS (U.S. CLS. 1, 5, 6, 10, 26 AND 46).

SCOTT BIBB, EXAMINING ATTORNEY

SN 79-093,839. I.B.R. ISRAELI BIOTECHNOLOGY RESEARCH LTD., ISRAEL, FILED 1-12-2011.

IBR-Gapture

THE MARK CONSISTS OF STANDARD CHARACTERS WITHOUT CLAIM TO ANY PARTICULAR FONT, STYLE, SIZE, OR COLOR.

PRIORITY DATE OF 10-25-2010 IS CLAIMED.

OWNER OF INTERNATIONAL REGISTRATION 1067835 DATED 1-12-2011, EXPIRES 1-12-2021.

OWNER OF U.S. REG. NOS. 2,543,703, 3,454,460 AND OTHERS.

FOR PLANT EXTRACTS IN THIS CLASS ONLY AS RAW MATERIAL FOR USE IN THE MANUFACTURE OF COSMETIC AND PHARMACEUTICAL PRODUCTS (U.S. CLS. 1, 5, 6, 10, 26 AND 46).

MICHAEL WIENER, EXAMINING ATTORNEY

CLASS 1—(Continued).

SN 79-093,872. EVONIK DEGUSSA GMBH, ESSEN, FED REP GERMANY, FILED 12-24-2010.

DDIS

THE MARK CONSISTS OF STANDARD CHARACTERS WITHOUT CLAIM TO ANY PARTICULAR FONT, STYLE, SIZE, OR COLOR.

OWNER OF INTERNATIONAL REGISTRATION 1067946 DATED 12-24-2010, EXPIRES 12-24-2020.

OWNER OF U.S. REG. NO. 2,413,504.

FOR CHEMICALS USED IN INDUSTRY, SCIENCE AND PHOTOGRAPHY, AS WELL AS FOR USE IN AGRICULTURE, HORTICULTURE AND FORESTRY, EXCEPT FUNGICIDES, HERBICIDES, INSECTICIDES AND PARASITICIDES; CHEMICAL PREPARATIONS FOR THE MANUFACTURE OF PAINTS, INKS AND LACQUERS; ALCOHOLS FOR INDUSTRIAL PURPOSES; CHEMICAL PREPARATIONS, NAMELY, HEXANEDIOLS FOR INDUSTRIAL PURPOSES; CHEMICAL PREPARATIONS FOR USE AS HUMECTANT IN INK JET INKS; UNPROCESSED ARTIFICIAL RESINS, UNPROCESSED PLASTICS; CHEMICALS USED IN INDUSTRY, NAMELY, ADHESIVES FOR INDUSTRIAL USE (U.S. CLS. 1, 5, 6, 10, 26 AND 46).

APRIL ROACH, EXAMINING ATTORNEY

SN 79-094,978. GIVAUDAN S.A., SWITZERLAND, FILED 3-2-2011.

CAPITALL

THE MARK CONSISTS OF STANDARD CHARACTERS WITHOUT CLAIM TO ANY PARTICULAR FONT, STYLE, SIZE, OR COLOR.

PRIORITY DATE OF 9-29-2010 IS CLAIMED.

OWNER OF INTERNATIONAL REGISTRATION 1070751 DATED 3-2-2011, EXPIRES 3-2-2021.

FOR CHEMICALS USED IN THE MANUFACTURE OF COMPOSITIONS OF PERFUMERY, OF COSMETICS, OF SOAPS, OF DETERGENTS, OF DEODORANTS FOR PERSONAL USE AND OF DEODORANTS OTHER THAN FOR PERSONAL USE (U.S. CLS. 1, 5, 6, 10, 26 AND 46).

ANNE E. GUSTASON, EXAMINING ATTORNEY

SN 85-101,762. SPI PHARMA, INC., WILMINGTON, DE. FILED 8-6-2010.

MANNOGEM

THE MARK CONSISTS OF STANDARD CHARACTERS WITHOUT CLAIM TO ANY PARTICULAR FONT, STYLE, SIZE, OR COLOR.

FOR CHEMICAL ADDITIVES, NAMELY, MANNITOL FOR USE IN THE MANUFACTURE OF FOOD AND PHARMACEUTICALS (U.S. CLS. 1, 5, 6, 10, 26 AND 46).

FIRST USE 4-1-1996; IN COMMERCE 4-1-1996.

DAVID ELTON, EXAMINING ATTORNEY

CLASS 1—(Continued).

SN 85-125,561. SUDHARSAN, JAI KRISHNA, BERNARDSVILLE, NJ. FILED 9-9-2010.

GREENOLEUM

THE MARK CONSISTS OF STANDARD CHARACTERS WITHOUT CLAIM TO ANY PARTICULAR FONT, STYLE, SIZE, OR COLOR.

FOR RENEWABLES BASED (GREEN) CHEMICAL PRODUCTS, NAMELY, CHEMICALS USED IN INDUSTRY, SCIENCE AND PHOTOGRAPHY, AS WELL AS IN AGRICULTURE, HORTICULTURE AND FORESTRY EXCEPT FUNGICIDES, HERBICIDES, INSECTICIDES AND PARASITICIDES, UNPROCESSED ARTIFICIAL RESINS, UNPROCESSED PLASTICS, MANURES, FIRE EXTINGUISHING COMPOSITIONS, TEMPERING AND SOLDERING PREPARATIONS, CHEMICAL SUBSTANCES FOR PRESERVING FOODSTUFFS, TANNING SUBSTANCES, NAMELY, ENZYMES FOR USE IN THE TANNING OF LEATHER, AND ADHESIVES USED IN INDUSTRY FOR CONSUMERS OF ALL AGES (U.S. CLS. 1, 5, 6, 10, 26 AND 46).

MICHELLE DUBOIS, EXAMINING ATTORNEY

SN 85-125,698. PT TIRTA MARTA, CIKUPA, TANGERANG, INDONESIA, FILED 9-9-2010.

OXIUM

THE MARK CONSISTS OF STANDARD CHARACTERS WITHOUT CLAIM TO ANY PARTICULAR FONT, STYLE, SIZE, OR COLOR.

FOR UNPROCESSED PLASTICS IN ALL FORMS; UNPROCESSED BIODEGRADABLE PLASTICS IN ALL FORMS; POLYETHYLENE RESIN; PLASTIC MOLDING COMPOUNDS FOR USE IN THE MANUFACTURE OF PLASTIC FILMS; AND UNPROCESSED EXTRUDABLE PLASTICS IN ALL FORMS (U.S. CLS. 1, 5, 6, 10, 26 AND 46).

DAVID TAYLOR, EXAMINING ATTORNEY

CLASS 1—(Continued).

SN 85-127,949. SABINSA CORPORATION, EAST WINDSOR, NJ. FILED 9-13-2010.



THE COLOR(S) BLUE AND WHITE IS/ARE CLAIMED AS A FEATURE OF THE MARK.

THE MARK CONSISTS OF LOWER CASE LETTERS FOR THE TEXT "AQUASOL" IN BLUE FONT WITH A LARGE DROPLET SHAPE IN LIGHT BLUE COLOR CONTAINING A DIFFUSED WHITE SPOT TOWARDS THE BOTTOM RIGHT; AND TWO PROGRESSIVELY SMALLER DARK BLUE FALLING DROPLETS ON THE LEFT SIDE OF THE LARGE DROPLET, EACH CONTAINING A DIFFUSED WHITE SPOT TOWARDS THE BOTTOM RIGHT.

FOR WATER SOLUBLE PHYTOCHEMICALS FOR USE AS INGREDIENTS IN DIETARY SUPPLEMENTS, FOOD PRODUCTS, AND COSMETICS (U.S. CLS. 1, 5, 6, 10, 26 AND 46).

RONALD AIKENS, EXAMINING ATTORNEY

SN 85-138,861. XYNETH MANUFACTURING CORP., BURNABY, B.C., CANADA, FILED 9-27-2010.

YELLOWSIGN CORNZORB

THE MARK CONSISTS OF STANDARD CHARACTERS WITHOUT CLAIM TO ANY PARTICULAR FONT, STYLE, SIZE, OR COLOR.

FOR BASED ON USE IN COMMERCE VEGETABLE-BASED COMPOSITION FOR SOLIDIFICATION OF FLUIDS AND ABSORPTION OF LIQUIDS, NAMELY, DRIED PROCESSED CORN COBS AND CORN PLANT PARTS; BASED ON INTENT TO USE VEGETABLE-BASED COMPOSITION USED TO MAINTAIN MOISTURE AND IMPROVE SOIL CONDITIONS, NAMELY, DRIED PROCESSED CORN COBS AND CORN PLANT PARTS (U.S. CLS. 1, 5, 6, 10, 26 AND 46).

FIRST USE 7-3-2008; IN COMMERCE 10-4-2008.
BRIDGETT SMITH, EXAMINING ATTORNEY

SN 85-161,809. UNIVERSAL COOPERATIVES, INC., EAGAN, MN. FILED 10-26-2010.

CROSSLINK

THE MARK CONSISTS OF STANDARD CHARACTERS WITHOUT CLAIM TO ANY PARTICULAR FONT, STYLE, SIZE, OR COLOR.

FOR AGRICULTURAL ADJUVANTS FOR USE WITH HERBICIDES, INSECTICIDES, AND PESTICIDES (U.S. CLS. 1, 5, 6, 10, 26 AND 46).

BILL DAWE, EXAMINING ATTORNEY

CLASS 1—(Continued).

SN 85-178,655. FRAGRANCE MARKETING GROUP, LLC, EDEN PRAIRIE, MN. FILED 11-17-2010.

EXSEED

THE MARK CONSISTS OF STANDARD CHARACTERS WITHOUT CLAIM TO ANY PARTICULAR FONT, STYLE, SIZE, OR COLOR.

FOR MOISTURIZING INGREDIENT USED IN MANUFACTURE OF PERSONAL CARE PRODUCTS (U.S. CLS. 1, 5, 6, 10, 26 AND 46).

JILL PRATER, EXAMINING ATTORNEY

SN 85-189,331. POWERS PRODUCTS III, L.L.C., BREWSTER, NY. FILED 12-2-2010.

PURE 110PRO

THE MARK CONSISTS OF STANDARD CHARACTERS WITHOUT CLAIM TO ANY PARTICULAR FONT, STYLE, SIZE, OR COLOR.

FOR INDUSTRIAL ADHESIVES; EPOXY RESIN; CONSTRUCTION INDUSTRY ADHESIVES; INDUSTRIAL ADHESIVES FOR MASONRY AND CONCRETE USE (U.S. CLS. 1, 5, 6, 10, 26 AND 46).

DAWN HAN, EXAMINING ATTORNEY

SN 85-193,003. CHROMADDEX INC., IRVINE, CA. FILED 12-8-2010.

**THE NEXT GENERATION
RESVERATROL**

THE MARK CONSISTS OF STANDARD CHARACTERS WITHOUT CLAIM TO ANY PARTICULAR FONT, STYLE, SIZE, OR COLOR.

NO CLAIM IS MADE TO THE EXCLUSIVE RIGHT TO USE "RESVERATROL", APART FROM THE MARK AS SHOWN.

FOR PHYTOCHEMICALS FOR USE IN THE MANUFACTURING OF DIETARY SUPPLEMENTS, NUTRITIONAL SUPPLEMENTS, NUTRITIONAL BEVERAGES, PHARMACEUTICALS AND COSMETICS (U.S. CLS. 1, 5, 6, 10, 26 AND 46).

SAIMA MAKHDOOM, EXAMINING ATTORNEY

CLASS 1—(Continued).

SN 85-257,003. ACTIVE ORGANICS, INC., LEWISVILLE, TX. FILED 3-3-2011.

ACTISTYLE

THE MARK CONSISTS OF STANDARD CHARACTERS WITHOUT CLAIM TO ANY PARTICULAR FONT, STYLE, SIZE, OR COLOR.

OWNER OF U.S. REG. NOS. 2,747,243, 3,067,333 AND OTHERS.

FOR ORGANIC BIOLOGICAL EXTRACTS FOR USE IN THE MANUFACTURE OF COSMETICS, SKIN CARE AND HAIR CARE PRODUCTS (U.S. CLS. 1, 5, 6, 10, 26 AND 46).

JANET LEE, EXAMINING ATTORNEY



SN 85-257,066. ACTIVE ORGANICS, INC., LEWISVILLE, TX. FILED 3-3-2011.

ACTIFOLIATE

THE MARK CONSISTS OF STANDARD CHARACTERS WITHOUT CLAIM TO ANY PARTICULAR FONT, STYLE, SIZE, OR COLOR.

OWNER OF U.S. REG. NOS. 2,747,243, 3,067,333 AND OTHERS.

FOR ORGANIC BIOLOGICAL EXTRACTS FOR USE IN THE MANUFACTURE OF COSMETICS, SKIN CARE AND HAIR CARE PRODUCTS (U.S. CLS. 1, 5, 6, 10, 26 AND 46).

JANET LEE, EXAMINING ATTORNEY

CLASS 1—(Continued).

SN 85-265,737. ZHEJIANG HANGZHOU XINFU PHARMACEUTICAL CO. LTD., ZHEJIANG, CHINA, FILED 3-14-2011.



XIN FU

THE MARK CONSISTS OF WORDING "XIN FU" APPEARING UNDER A DARKENED CIRCLE CONTAINING A DESIGN CONSISTING OF THREE PARALLEL LINES COMPRISING A FOLDED RIBBON.

THE WORDING "XINFU" HAS NO MEANING IN A FOREIGN LANGUAGE.

FOR ORGANIC CHEMICAL ADDITIVES FOR USE IN THE MANUFACTURE OF FODDER; ORGANIC CHEMICAL ADDITIVES FOR USE IN THE MANUFACTURE OF VITAMINS; PANTOTHENIC ACID FOR USE IN THE MANUFACTURE OF VITAMINS (U.S. CLS. 1, 5, 6, 10, 26 AND 46).

FIRST USE 11-0-1998; IN COMMERCE 5-0-1999.

KATHERINE STOIDES, EXAMINING ATTORNEY



SN 85-265,806. COGNIS IP MANAGEMENT GMBH, 40589 DUESSELDORF, FED REP GERMANY, FILED 3-14-2011.

SANICAPYL

THE MARK CONSISTS OF STANDARD CHARACTERS WITHOUT CLAIM TO ANY PARTICULAR FONT, STYLE, SIZE, OR COLOR.

FOR CHEMICAL PREPARATIONS IN THE NATURE OF EXTRACTS OF NATURAL, VEGETAL, MARINE, SYNTHETIC OR BIOTECHNOLOGICAL ORIGIN AND INTENDED FOR THE MANUFACTURE OF COSMETIC PRODUCTS AND SANITARY PREPARATIONS FOR COSMETIC BODY, HAIR, AND FACE CARE (U.S. CLS. 1, 5, 6, 10, 26 AND 46).

JOHN GARTNER, EXAMINING ATTORNEY

CLASS 1—(Continued).

SN 85-269,659. ASIA CHEMICAL CORPORATION, INC., HOUSTON, TX. FILED 3-17-2011.

Imperial Microspheres

THE MARK CONSISTS OF STANDARD CHARACTERS WITHOUT CLAIM TO ANY PARTICULAR FONT, STYLE, SIZE, OR COLOR.

NO CLAIM IS MADE TO THE EXCLUSIVE RIGHT TO USE "MICROSPHERES", APART FROM THE MARK AS SHOWN.

FOR ACRYLIC POLYMER POWDERS (U.S. CLS. 1, 5, 6, 10, 26 AND 46).

FIRST USE 1-12-2010; IN COMMERCE 1-13-2010.
CHRISTINA SOBRAL, EXAMINING ATTORNEY

CLASS 1—(Continued).

SN 85-275,260. JONES, SHAUN, DBA SJ ENTERPRISES, ADELAIDE, AUSTRALIA, FILED 3-24-2011.

OWNER OF AUSTRALIA REG. NO. 1293521, DATED 4-8-2009, EXPIRES 4-8-2019.

THE MARK CONSISTS OF THE WORDING "CYCO" WHERE THE LETTERS APPEAR TO BE CUT HORIZONTALLY IN HALF AND A CRACK DESIGN APPEARS AT THE TOP PORTION OF THE TWO "C"'S IN THE MARK.

FOR CHEMICAL FERTILIZERS (U.S. CLS. 1, 5, 6, 10, 26 AND 46).

FIRST USE 1-2-2008; IN COMMERCE 1-5-2008.
CHRISTINE COOPER, EXAMINING ATTORNEY

SN 85-272,682. STANDARD CABLE USA, INC., RANCHO SANTA MARGARITA, CA. FILED 3-21-2011.

KYLENE

THE MARK CONSISTS OF STANDARD CHARACTERS WITHOUT CLAIM TO ANY PARTICULAR FONT, STYLE, SIZE, OR COLOR.

FOR POLYMERS FOR USE IN THE MANUFACTURE OF POWER CORDS, POWER CABLES, ELECTRIC PLUGS, ELECTRICAL WIRES AND WIRE HARNESS ASSEMBLIES (U.S. CLS. 1, 5, 6, 10, 26 AND 46).

NORA BUCHANAN WILL, EXAMINING ATTORNEY

SN 85-277,598. NATURAL POOL PRODUCTS, INC., MCKINNEY, TX. FILED 3-25-2011.

Naturally Blue Phosphate Remover

THE MARK CONSISTS OF STANDARD CHARACTERS WITHOUT CLAIM TO ANY PARTICULAR FONT, STYLE, SIZE, OR COLOR.

NO CLAIM IS MADE TO THE EXCLUSIVE RIGHT TO USE "NATURALLY" AND "PHOSPHATE REMOVER", APART FROM THE MARK AS SHOWN.

FOR WATER PURIFYING CHEMICALS FOR SWIMMING POOLS; WATER TREATMENT CHEMICALS FOR USE IN SWIMMING POOLS AND SPAS (U.S. CLS. 1, 5, 6, 10, 26 AND 46).

FIRST USE 6-1-2010; IN COMMERCE 6-1-2010.
CHRIS WELLS, EXAMINING ATTORNEY

SN 85-273,923. REC SILICON INC, MOSES LAKE, WA. FILED 3-22-2011.

SIGNATURE POLYSILICON

THE MARK CONSISTS OF STANDARD CHARACTERS WITHOUT CLAIM TO ANY PARTICULAR FONT, STYLE, SIZE, OR COLOR.

NO CLAIM IS MADE TO THE EXCLUSIVE RIGHT TO USE "POLYSILICON", APART FROM THE MARK AS SHOWN.

FOR CHEMICAL PRODUCTS CONTAINING SILICON FOR USE IN THE MANUFACTURE OF PHOTOVOLTAIC PRODUCTS, SEMI-CONDUCTORS, AND ELECTRONICS; AND SILICON FOR INDUSTRIAL USE, NAMELY, SILICON WAFERS FOR USE IN MAKING SOLAR CELLS, SILICON WAFERS, SOLAR CELL MODULES, SOLAR PANELS, SEMI-CONDUCTORS, AND ELECTRONICS (U.S. CLS. 1, 5, 6, 10, 26 AND 46).

JOHN E. MICHOS, EXAMINING ATTORNEY

SN 85-277,606. NATURAL POOL PRODUCTS, INC., MCKINNEY, TX. FILED 3-25-2011.

Naturally BluePRO Phosphate Remover

THE MARK CONSISTS OF STANDARD CHARACTERS WITHOUT CLAIM TO ANY PARTICULAR FONT, STYLE, SIZE, OR COLOR.

NO CLAIM IS MADE TO THE EXCLUSIVE RIGHT TO USE "NATURALLY" AND "PHOSPHATE REMOVER", APART FROM THE MARK AS SHOWN.

FOR WATER PURIFYING CHEMICALS FOR SWIMMING POOLS; WATER TREATMENT CHEMICALS FOR USE IN SWIMMING POOLS AND SPAS (U.S. CLS. 1, 5, 6, 10, 26 AND 46).

FIRST USE 6-1-2010; IN COMMERCE 6-1-2010.
CHRIS WELLS, EXAMINING ATTORNEY

CLASS 1—(Continued).

SN 85-277,619. NATURAL POOL PRODUCTS, INC., MCKINNEY, TX. FILED 3-25-2011.

Naturally Free Metal & Scale Control

THE MARK CONSISTS OF STANDARD CHARACTERS WITHOUT CLAIM TO ANY PARTICULAR FONT, STYLE, SIZE, OR COLOR.

NO CLAIM IS MADE TO THE EXCLUSIVE RIGHT TO USE "NATURALLY" AND "METAL SCALE CONTROL", APART FROM THE MARK AS SHOWN.

FOR WATER PURIFYING CHEMICALS FOR SWIMMING POOLS; WATER TREATMENT CHEMICALS FOR USE IN SWIMMING POOLS AND SPAS (U.S. CLS. 1, 5, 6, 10, 26 AND 46).

FIRST USE 6-1-2010; IN COMMERCE 6-1-2010.
CHRIS WELLS, EXAMINING ATTORNEY

CLASS 1—(Continued).

SN 85-290,087. CAW INDUSTRIES, INC., RAPID CITY, SD. FILED 4-8-2011.

CAW WATER

THE MARK CONSISTS OF STANDARD CHARACTERS WITHOUT CLAIM TO ANY PARTICULAR FONT, STYLE, SIZE, OR COLOR.

OWNER OF U.S. REG. NOS. 1,081,448 AND 1,770,941.

NO CLAIM IS MADE TO THE EXCLUSIVE RIGHT TO USE "WATER", APART FROM THE MARK AS SHOWN.

FOR CHEMICALS, NAMELY, AQUEOUS CATALYST-CONTAINING COMPOSITIONS IN LIQUID OR GEL FORM FOR USE IN ALTERING THE PROPERTIES OF LIQUID WATER, AND FOR GENERAL USE IN AGRICULTURE AND HORTICULTURE, FOR USE IN WASHING, CLEANING, DISINFECTING AND SANITIZING IN HOUSEHOLD, INDUSTRIAL, AND INSTITUTIONAL APPLICATIONS, FOR USE IN PERSONAL CARE, SKIN CARE AND COSMETIC APPLICATIONS, SHAMPOOING AND HAIR TREATING, FOR USE IN PHARMACEUTICAL, MEDICINAL AND VETERINARY APPLICATIONS, IN HOLISTIC AND HOMEOPATHIC MEDICINE APPLICATIONS, IN DIETARY SUPPLEMENT AND NUTRITIONAL SUPPLEMENTS, AND FOR USE IN TREATING CARBONACEOUS FOSSIL FUELS AND BITUMINOUS MATERIALS (U.S. CLS. 1, 5, 6, 10, 26 AND 46).

ALLISON SCHRODY, EXAMINING ATTORNEY

SN 85-287,575. PUCCIONI USA, LLC, OLDWICK, NJ. FILED 4-6-2011.



NO CLAIM IS MADE TO THE EXCLUSIVE RIGHT TO USE "1888, USA" AND "FERTILIZERS", APART FROM THE MARK AS SHOWN.

THE COLOR(S) YELLOW, BLACK, GREEN AND BLUE IS/ARE CLAIMED AS A FEATURE OF THE MARK.

THE MARK CONSISTS OF A YELLOW SQUARE WITH THE LETTER "P" COLORED IN BLACK IN THE MIDDLE OF THE SQUARE AND THE YEAR 1888 LISTED BELOW THE LETTER "P" IN THE LOWER RIGHT CORNER OF THE SQUARE. ALONGSIDE THE SQUARE IS THE WORD "PUCCIONI" COLORED IN YELLOW WITH THE LETTERS "USA" IN A VERTICAL POSITION COLORED IN YELLOW, LOCATED ON A BLACK BACKGROUND. THE WORD "FERTILIZERS" IS WRITTEN IN BLACK AND LOCATED ON A YELLOW BORDER BELOW THE SQUARE WITH 1888 AND THE WORDS "PUCCIONI USA". BELOW THE YELLOW BORDER IS THE BLUE SKY WITH ROLLING HILLS OF CULTIVATED LAND COLORED GREEN WITH SHADED BLACK AREAS WITH STALKS OF GRAINS COLORED IN YELLOW AND SHADED WITH BLACK.

FOR PLANT NUTRITION PREPARATIONS (U.S. CLS. 1, 5, 6, 10, 26 AND 46).

NORA BUCHANAN WILL, EXAMINING ATTORNEY

SN 85-291,416. RIVER DAY PROPERTIES, DBA PLANTS ON WALLS, SAN FRANCISCO, CA. FILED 4-11-2011.

FLORAFELT

THE MARK CONSISTS OF STANDARD CHARACTERS WITHOUT CLAIM TO ANY PARTICULAR FONT, STYLE, SIZE, OR COLOR.

FOR GROWING MEDIA FOR PLANTS (U.S. CLS. 1, 5, 6, 10, 26 AND 46).

FIRST USE 1-1-2010; IN COMMERCE 1-1-2010.

FRANK LATTUCA, EXAMINING ATTORNEY

SN 85-291,823. W. R. GRACE & CO.-CONN., COLUMBIA, MD. FILED 4-11-2011.

REBEL

THE MARK CONSISTS OF STANDARD CHARACTERS WITHOUT CLAIM TO ANY PARTICULAR FONT, STYLE, SIZE, OR COLOR.

FOR CHEMICALS, NAMELY, PRODUCTS USED IN FLUID CATALYTIC CRACKING PROCESSES IN THE PETROLEUM AND REFINING INDUSTRIES (U.S. CLS. 1, 5, 6, 10, 26 AND 46).

WENDY JUN, EXAMINING ATTORNEY

CLASS 1—(Continued).

SN 85-291,836. W. R. GRACE & CO.-CONN., COLUMBIA, MD. FILED 4-11-2011.

REMEDY

THE MARK CONSISTS OF STANDARD CHARACTERS WITHOUT CLAIM TO ANY PARTICULAR FONT, STYLE, SIZE, OR COLOR.

FOR CHEMICALS, NAMELY, PRODUCTS USED IN FLUID CATALYTIC CRACKING PROCESSES IN THE PETROLEUM AND REFINING INDUSTRIES (U.S. CLS. 1, 5, 6, 10, 26 AND 46).

WENDY JUN, EXAMINING ATTORNEY

SN 85-291,846. W. R. GRACE & CO.-CONN., COLUMBIA, MD. FILED 4-11-2011.

RESIDXTRA

THE MARK CONSISTS OF STANDARD CHARACTERS WITHOUT CLAIM TO ANY PARTICULAR FONT, STYLE, SIZE, OR COLOR.

FOR CHEMICALS, NAMELY, PRODUCTS USED IN FLUID CATALYTIC CRACKING PROCESSES IN THE PETROLEUM AND REFINING INDUSTRIES (U.S. CLS. 1, 5, 6, 10, 26 AND 46).

WENDY JUN, EXAMINING ATTORNEY

SN 85-292,160. POLYONE CORPORATION, AVON LAKE, OH. FILED 4-11-2011.

DOMINION

THE MARK CONSISTS OF STANDARD CHARACTERS WITHOUT CLAIM TO ANY PARTICULAR FONT, STYLE, SIZE, OR COLOR.

FOR UNPROCESSED THERMOPLASTIC CONCENTRATES AND THERMOPLASTIC COMPOUNDS, BOTH FOR USE IN MAKING PLASTIC ARTICLES (U.S. CLS. 1, 5, 6, 10, 26 AND 46).

SUSAN LESLIE DUBOIS, EXAMINING ATTORNEY

CLASS 1—(Continued).

SN 85-292,830. SMOKEFAX, INC., HOUSTON, TX. FILED 4-12-2011.

SMOKEFAX

THE MARK CONSISTS OF STANDARD CHARACTERS WITHOUT CLAIM TO ANY PARTICULAR FONT, STYLE, SIZE, OR COLOR.

FOR CHEMICAL TEST PAPER (U.S. CLS. 1, 5, 6, 10, 26 AND 46).

GIANCARLO CASTRO, EXAMINING ATTORNEY

SN 85-292,933. PUCCIONI USA, OLDWICK, NJ. FILED 4-12-2011.



NO CLAIM IS MADE TO THE EXCLUSIVE RIGHT TO USE "1888", "USA" AND "FERTILIZERS", APART FROM THE MARK AS SHOWN.

THE COLOR(S) YELLOW AND BLACK IS/ARE CLAIMED AS A FEATURE OF THE MARK.

THE MARK CONSISTS OF TO A YELLOW SQUARE WITH THE LETTER "P" COLORED IN BLACK IN THE MIDDLE OF THE SQUARE AND THE YEAR 1888 LISTED BELOW THE LETTER "P" IN THE LOWER RIGHT CORNER OF THE SQUARE. ALONGSIDE THE SQUARE IS THE WORD "PUCCIONI" COLORED IN YELLOW WITH THE LETTERS "USA" IN A VERTICAL POSITION COLORED IN YELLOW, LOCATED ON A BLACK BACKGROUND. THE WORD "FERTILIZERS" IS WRITTEN IN BLACK AND LOCATED ON A YELLOW BORDER BELOW THE SQUARE WITH 1888 AND THE WORDS "PUCCIONI USA".

FOR PLANT NUTRITION PREPARATIONS FOR DOMESTIC USE (U.S. CLS. 1, 5, 6, 10, 26 AND 46).

NORA BUCHANAN WILL, EXAMINING ATTORNEY

SN 85-293,150. MULTISORB TECHNOLOGIES, INC., BUFFALO, NY. FILED 4-12-2011.

ALUDRI

THE MARK CONSISTS OF STANDARD CHARACTERS WITHOUT CLAIM TO ANY PARTICULAR FONT, STYLE, SIZE, OR COLOR.

FOR DESICCANTS (U.S. CLS. 1, 5, 6, 10, 26 AND 46).

JOHN WILKE, EXAMINING ATTORNEY

CLASS 1—(Continued).

SN 85-293,190. MULTISORB TECHNOLOGIES, INC., BUFFALO, NY. FILED 4-12-2011.

DRIMAC

THE MARK CONSISTS OF STANDARD CHARACTERS WITHOUT CLAIM TO ANY PARTICULAR FONT, STYLE, SIZE, OR COLOR.
FOR CHEMICALS FOR ABSORBING OXYGEN; DESICCANTS; HUMECTANTS (U.S. CLS. 1, 5, 6, 10, 26 AND 46).
JOHN WILKE, EXAMINING ATTORNEY

SN 85-293,211. MULTISORB TECHNOLOGIES, INC., BUFFALO, NY. FILED 4-12-2011.

STATDRI

THE MARK CONSISTS OF STANDARD CHARACTERS WITHOUT CLAIM TO ANY PARTICULAR FONT, STYLE, SIZE, OR COLOR.
FOR DESICCANTS; HUMECTANTS (U.S. CLS. 1, 5, 6, 10, 26 AND 46).
JOHN WILKE, EXAMINING ATTORNEY

SN 85-293,235. MULTISORB TECHNOLOGIES, INC., BUFFALO, NY. FILED 4-12-2011.

CARGODRI

THE MARK CONSISTS OF STANDARD CHARACTERS WITHOUT CLAIM TO ANY PARTICULAR FONT, STYLE, SIZE, OR COLOR.
FOR DESICCATING BAGS FOR USE IN FREIGHT CONTAINERS AND OTHER TRANSPORTATION APPLICATIONS (U.S. CLS. 1, 5, 6, 10, 26 AND 46).
JOHN WILKE, EXAMINING ATTORNEY

CLASS 1—(Continued).

SN 85-293,286. VALENT BIOSCIENCES CORPORATION, LIBERTYVILLE, IL. FILED 4-12-2011.

POMAXA

THE MARK CONSISTS OF STANDARD CHARACTERS WITHOUT CLAIM TO ANY PARTICULAR FONT, STYLE, SIZE, OR COLOR.
FOR PLANT GROWTH REGULATING PREPARATIONS (U.S. CLS. 1, 5, 6, 10, 26 AND 46).
HANNO RITTNER, EXAMINING ATTORNEY

SN 85-293,461. ALLIED BIOSCIENCE SERVICES, INC., POINT ROBERTS, WA. FILED 4-12-2011.

GERMMAX

THE MARK CONSISTS OF STANDARD CHARACTERS WITHOUT CLAIM TO ANY PARTICULAR FONT, STYLE, SIZE, OR COLOR.
FOR A CHEMICAL AGENT TO DECREASE GROWTH RATE OF MICROBES ON A SURFACE (U.S. CLS. 1, 5, 6, 10, 26 AND 46).
EDWARD NELSON, EXAMINING ATTORNEY

SN 85-295,238. DANISE & ASSOCIATES, INC., DBA SOUTHERN ORGANICS & SUPPLY, MONROE, NC. FILED 4-14-2011.

VERMAMAX

THE MARK CONSISTS OF STANDARD CHARACTERS WITHOUT CLAIM TO ANY PARTICULAR FONT, STYLE, SIZE, OR COLOR.
FOR ORGANIC FERTILIZER AND SOIL CONDITIONER FOR PLANTS, TREES, SHRUBS, FLOWERS, VEGETABLES, FRUITS AND LAWNS (U.S. CLS. 1, 5, 6, 10, 26 AND 46).
FIRST USE 7-27-2010; IN COMMERCE 7-27-2010.
CHRISTINA SOBRAL, EXAMINING ATTORNEY

CLASS 1—(Continued).

SN 85-295,315. W. R. GRACE & CO.-CONN, COLUMBIA, MD.
FILED 4-14-2011.

ENPURE

THE MARK CONSISTS OF STANDARD CHARACTERS
WITHOUT CLAIM TO ANY PARTICULAR FONT, STYLE,
SIZE, OR COLOR.

FOR CHEMICALS - NAMELY, INORGANIC OXIDES
FOR USE IN REFINING AND/OR PURIFYING OF
BIOFUELS (U.S. CLS. 1, 5, 6, 10, 26 AND 46).

JOHN HWANG, EXAMINING ATTORNEY

SN 85-295,810. LEONARD M. ESPOSITO, DBA LME PRO-
DUCTS INC., JAMAICA, NY. FILED 4-14-2011.

SolBotanique

THE MARK CONSISTS OF STANDARD CHARACTERS
WITHOUT CLAIM TO ANY PARTICULAR FONT, STYLE,
SIZE, OR COLOR.

FOR BOTANICAL EXTRACTS FOR USE IN MAKING
COSMETICS (U.S. CLS. 1, 5, 6, 10, 26 AND 46).

ANDREA HACK, EXAMINING ATTORNEY

SN 85-296,372. W. R. GRACE & CO.-CONN., COLUMBIA,
MD. FILED 4-15-2011.

RESIDULTRA

THE MARK CONSISTS OF STANDARD CHARACTERS
WITHOUT CLAIM TO ANY PARTICULAR FONT, STYLE,
SIZE, OR COLOR.

FOR CHEMICALS, NAMELY, PRODUCTS USED IN
FLUID CATALYTIC CRACKING PROCESSES IN THE
PETROLEUM AND REFINING INDUSTRIES (U.S. CLS.
1, 5, 6, 10, 26 AND 46).

WENDY JUN, EXAMINING ATTORNEY

CLASS 1—(Continued).

SN 85-296,661. MULTISORB TECHNOLOGIES, INC., BUF-
FALO, NY. FILED 4-15-2011.

ETHYDRI

THE MARK CONSISTS OF STANDARD CHARACTERS
WITHOUT CLAIM TO ANY PARTICULAR FONT, STYLE,
SIZE, OR COLOR.

FOR CHEMICALS FOR ABSORBING ETHYLENE (U.S.
CLS. 1, 5, 6, 10, 26 AND 46).

JOHN WILKE, EXAMINING ATTORNEY

SN 85-297,413. MITSUBISHI GAS CHEMICAL COMPANY,
INC., TOKYO, JAPAN, FILED 4-18-2011.

H-TMA_n

THE MARK CONSISTS OF STANDARD CHARACTERS
WITHOUT CLAIM TO ANY PARTICULAR FONT, STYLE,
SIZE, OR COLOR.

FOR CHEMICALS, NAMELY, ORGANIC ACIDS, OR-
GANIC ACIDS ANHYDRIDE, FOR INDUSTRIAL USE
(U.S. CLS. 1, 5, 6, 10, 26 AND 46).

ERNEST SHOSHO, EXAMINING ATTORNEY

SN 85-300,263. BRANDT CONSOLIDATED, INC., SPRING-
FIELD, IL. FILED 4-20-2011.

SMART TRIO

THE MARK CONSISTS OF STANDARD CHARACTERS
WITHOUT CLAIM TO ANY PARTICULAR FONT, STYLE,
SIZE, OR COLOR.

FOR AGRICULTURAL CHEMICALS, INCLUDING
MANGANESE, ZINC AND BORON, FOR IMPROVING
THE PHYSICAL AND BIOLOGICAL COMPATIBILITY
OF MICRONUTRIENTS WITH PESTICIDES (U.S. CLS. 1,
5, 6, 10, 26 AND 46).

FIRST USE 3-9-2010; IN COMMERCE 3-9-2010.

VIVIAN MICZNIK FIRST, EXAMINING ATTORNEY

CLASS 1—(Continued).

SN 85-304,325. NATURAL PACK, INC., SANTA BARBARA, CA. FILED 4-25-2011.

HARD COIR

THE MARK CONSISTS OF STANDARD CHARACTERS WITHOUT CLAIM TO ANY PARTICULAR FONT, STYLE, SIZE, OR COLOR.

FOR PLANTING SOIL, SUBSTRATES, AND FERTILIZERS (U.S. CLS. 1, 5, 6, 10, 26 AND 46).
MIDGE BUTLER, EXAMINING ATTORNEY

SN 85-304,398. ORGANIC SOIL BUILDERS, INC, KINGSBURG, CA. FILED 4-26-2011.

MAXI-K SUPREME

THE MARK CONSISTS OF STANDARD CHARACTERS WITHOUT CLAIM TO ANY PARTICULAR FONT, STYLE, SIZE, OR COLOR.

FOR FERTILIZERS, NAMELY, A NATURAL ORGANIC SOIL AMENDMENT, IN LIQUID FORM, THAT SUPPLIES ORGANIC MATTER TO PLANTS AND THEIR SOIL/ROOT ZONE, THAT WILL ENCOURAGE VIGOROUS GROWTH (U.S. CLS. 1, 5, 6, 10, 26 AND 46).
FIRST USE 1-1-2011; IN COMMERCE 1-1-2011.

MORGAN WYNNE, EXAMINING ATTORNEY

SN 85-308,380. MOMENTIVE PERFORMANCE MATERIALS INC., ALBANY, NY. FILED 4-29-2011.

SPUR+

THE MARK CONSISTS OF STANDARD CHARACTERS WITHOUT CLAIM TO ANY PARTICULAR FONT, STYLE, SIZE, OR COLOR.

FOR UNPROCESSED SYNTHETIC POLYMERIC RESINS FOR USE AS A BINDER IN COATINGS, ADHESIVES OR SEALANTS; CHEMICAL AGENTS IN THE NATURE OF POLYMERIC RESINS FOR USE AS A BINDER IN COATINGS, ADHESIVES OR SEALANTS FOR USE IN THE BUILDING AND CONSTRUCTION INDUSTRIES (U.S. CLS. 1, 5, 6, 10, 26 AND 46).
FIRST USE 11-30-2005; IN COMMERCE 11-30-2005.

CHARISMA HAMPTON, EXAMINING ATTORNEY

CLASS 1—(Continued).

SN 85-314,245. PRIMEX PLASTICS CORP., RICHMOND, IN. FILED 5-6-2011.

BLOCK-AID

THE MARK CONSISTS OF STANDARD CHARACTERS WITHOUT CLAIM TO ANY PARTICULAR FONT, STYLE, SIZE, OR COLOR.

FOR CHEMICAL ADDITIVES TO BE ADDED TO PLASTIC DURING THE MANUFACTURING PROCESS TO PREVENT THE GROWTH OF BACTERIA ON ITS SURFACE (U.S. CLS. 1, 5, 6, 10, 26 AND 46).
KATHLEEN M. VANSTON, EXAMINING ATTORNEY

SN 85-314,406. ALLIED BIOSCIENCE SERVICES, INC., POINT ROBERTS, WA. FILED 5-6-2011.

MOLDMAX

THE MARK CONSISTS OF STANDARD CHARACTERS WITHOUT CLAIM TO ANY PARTICULAR FONT, STYLE, SIZE, OR COLOR.

FOR A CHEMICAL AGENT TO MINIMIZE GROWTH RATE OF MOLD ON A SURFACE (U.S. CLS. 1, 5, 6, 10, 26 AND 46).

EDWARD NELSON, EXAMINING ATTORNEY

SN 85-324,926. CYTEC INDUSTRIES INC., WOODLAND PARK, NJ. FILED 5-19-2011.

CYFLOC

THE MARK CONSISTS OF STANDARD CHARACTERS WITHOUT CLAIM TO ANY PARTICULAR FONT, STYLE, SIZE, OR COLOR.

FOR COAGULANT AND FLOCCULANT FOR USE IN THE ALUMINA AND MINERAL PROCESSING INDUSTRIES (U.S. CLS. 1, 5, 6, 10, 26 AND 46).

WARREN L. OLANDRIA, EXAMINING ATTORNEY

CLASS 1—(Continued).

SN 85-327,415. THE DOW CHEMICAL COMPANY, MIDLAND, MI. FILED 5-23-2011.

MAXIBOOST

THE MARK CONSISTS OF STANDARD CHARACTERS WITHOUT CLAIM TO ANY PARTICULAR FONT, STYLE, SIZE, OR COLOR.

FOR CHEMICAL SOLVENT ADDITIVES USED IN INDUSTRY AND SCIENCE USED TO CONTROL AND COUNTERACT ACIDS (U.S. CLS. 1, 5, 6, 10, 26 AND 46).

FIRST USE 7-29-2005; IN COMMERCE 7-29-2005.
WON TEAK OH, EXAMINING ATTORNEY

SN 85-335,795. SEACHEM LABORATORIES, INC., MADISON, GA. FILED 6-1-2011.

Clarity

THE MARK CONSISTS OF STANDARD CHARACTERS WITHOUT CLAIM TO ANY PARTICULAR FONT, STYLE, SIZE, OR COLOR.

FOR CHEMICAL AQUARIUM WATER CONDITIONERS, NAMELY, CHEMICAL BLEND USED TO MAKE AQUARIUM WATER CLEANER (U.S. CLS. 1, 5, 6, 10, 26 AND 46).

FIRST USE 9-1-2002; IN COMMERCE 9-1-2002.
SHANNON TWOHIG, EXAMINING ATTORNEY

CLASS 2—PAINTS

SN 85-125,962. ALCOA INC., PITTSBURGH, PA. FILED 9-9-2010.

ECOCLEAN

THE MARK CONSISTS OF STANDARD CHARACTERS WITHOUT CLAIM TO ANY PARTICULAR FONT, STYLE, SIZE, OR COLOR.

FOR COATING, NAMELY, CLEAR COATING PROTECTANT FOR ALUMINUM SURFACES (U.S. CLS. 6, 11 AND 16).

KEVON CHISOLM, EXAMINING ATTORNEY

CLASS 2—(Continued).

SN 85-135,559. J.R. SIMPLOT COMPANY, BOISE, ID. FILED 9-22-2010.

TRACER

THE MARK CONSISTS OF STANDARD CHARACTERS WITHOUT CLAIM TO ANY PARTICULAR FONT, STYLE, SIZE, OR COLOR.

FOR WATER-SOLUBLE COLORANT FOR USE AS A SPRAY PATTERN INDICATOR (U.S. CLS. 6, 11 AND 16).
JILL C. ALT, EXAMINING ATTORNEY

SN 85-136,277. ABRO INDUSTRIES, INC., SOUTH BEND, IN. FILED 9-23-2010.



THE COLOR(S) BLACK, WHITE, PINK, RED, DARK ORANGE, LIGHT ORANGE, YELLOW, YELLOW-GREEN, LIGHT GREEN, DARK GREEN, BLUE-GREEN AND LIGHT BLUE IS/ARE CLAIMED AS A FEATURE OF THE MARK.

THE MARK CONSISTS OF A DESIGN OF A SOCCER PLAYER. THE SOCCER PLAYER IS WHITE AND BLACK AND IS SITUATED ON A RAINBOW COLORED BACKGROUND THAT INCLUDES THE FOLLOWING COLORS IN THIS ORDER - PINK, RED, DARK ORANGE, LIGHT ORANGE, YELLOW, YELLOW-GREEN, LIGHT GREEN, DARK GREEN, BLUE-GREEN AND LIGHT BLUE; THE SOCCER BALL INCLUDES ALL OF THE SAME COLORS AND BLACK.

FOR PAINT (U.S. CLS. 6, 11 AND 16).
FIRST USE 1-1-1990; IN COMMERCE 1-1-1990.
NAKIA HENRY, EXAMINING ATTORNEY

CLASS 2—(Continued).

SN 85-236,418. THE MARISHAWN GROUP, INC., ARLINGTON, TX. FILED 2-8-2011.

PAN-COAT

THE MARK CONSISTS OF STANDARD CHARACTERS WITHOUT CLAIM TO ANY PARTICULAR FONT, STYLE, SIZE, OR COLOR.

OWNER OF U.S. REG. NO. 2,996,122. SEC. 2(F).

FOR COATINGS IN THE NATURE OF INDUSTRIAL SEALANTS FOR WATERPROOFING, RUST AND MOLD PREVENTATIVES IN THE NATURE OF A COATING, ALL APPLIED TO PRODUCTS PRIMARILY IN THE HEATING, VENTILATION AND AIR CONDITIONING INDUSTRY (U.S. CLS. 6, 11 AND 16).

FIRST USE 7-1-2001; IN COMMERCE 7-1-2001.
CHARISMA HAMPTON, EXAMINING ATTORNEY

SN 85-268,554. MEDALLION INDUSTRIES, INC., CHICAGO, IL. FILED 3-16-2011.

GET IT GREEN

THE MARK CONSISTS OF STANDARD CHARACTERS WITHOUT CLAIM TO ANY PARTICULAR FONT, STYLE, SIZE, OR COLOR.

NO CLAIM IS MADE TO THE EXCLUSIVE RIGHT TO USE "GREEN", APART FROM THE MARK AS SHOWN.

FOR COLORANT FOR FLORA, LAWN, PLANTS, MULCH, TURF AND WOODCHIPS (U.S. CLS. 6, 11 AND 16).

FIRST USE 11-30-2009; IN COMMERCE 11-30-2009.
JOHN DWYER, EXAMINING ATTORNEY

SN 85-272,464. PREMIER DEALER SERVICES, INC., SAN DIEGO, CA. FILED 3-21-2011.

Premier Defense Paint Sealant

THE MARK CONSISTS OF STANDARD CHARACTERS WITHOUT CLAIM TO ANY PARTICULAR FONT, STYLE, SIZE, OR COLOR.

NO CLAIM IS MADE TO THE EXCLUSIVE RIGHT TO USE "PAINT SEALANT", APART FROM THE MARK AS SHOWN.

FOR PAINT SEALANT FOR EXTERIOR SURFACE OF A VEHICLE (U.S. CLS. 6, 11 AND 16).

HEATHER THOMPSON, EXAMINING ATTORNEY

CLASS 2—(Continued).

SN 85-272,474. PREMIER DEALER SERVICES, INC., SAN DIEGO, CA. FILED 3-21-2011.

Premier Defense Rust Proofing

THE MARK CONSISTS OF STANDARD CHARACTERS WITHOUT CLAIM TO ANY PARTICULAR FONT, STYLE, SIZE, OR COLOR.

NO CLAIM IS MADE TO THE EXCLUSIVE RIGHT TO USE "RUST PROOFING", APART FROM THE MARK AS SHOWN.

FOR RUST INHIBITING PREPARATIONS IN THE NATURE OF A COATING FOR USE ON VEHICLES (U.S. CLS. 6, 11 AND 16).

HEATHER THOMPSON, EXAMINING ATTORNEY

SN 85-272,480. PREMIER DEALER SERVICES, INC., SAN DIEGO, CA. FILED 3-21-2011.

Premier Defense Undercoating

THE MARK CONSISTS OF STANDARD CHARACTERS WITHOUT CLAIM TO ANY PARTICULAR FONT, STYLE, SIZE, OR COLOR.

NO CLAIM IS MADE TO THE EXCLUSIVE RIGHT TO USE "UNDERCOATING", APART FROM THE MARK AS SHOWN.

FOR AUTOMOBILE UNDERCOATING TO PROTECT UNDERCARRIAGE AGAINST RUST AND TO REDUCE CABIN NOISE (U.S. CLS. 6, 11 AND 16).

HEATHER THOMPSON, EXAMINING ATTORNEY

SN 85-276,562. AKZO NOBEL COATINGS INTERNATIONAL B.V., ARNHEM, NETHERLANDS, FILED 3-25-2011.

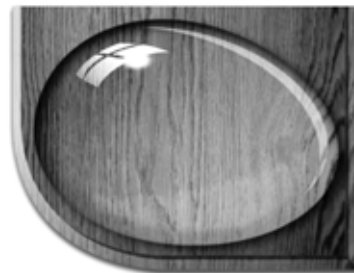

THE MARK CONSISTS OF A DROPLET OF LIQUID ON A WOODEN BOARD.

FOR WOOD DYES; WOOD STAINS; WOOD VARNISHES; PRESERVATIVES AGAINST THE DETE-RIORATION OF WOOD (U.S. CLS. 6, 11 AND 16).

JOHN WILKE, EXAMINING ATTORNEY

CLASS 2—(Continued).

SN 85-286,200. JOVIAL INC., DBA SILVER SAILS PAINTS, RIVER VALE, NJ. FILED 4-5-2011.



THE COLOR(S) BLUE, SILVER, AND BLACK IS/ARE CLAIMED AS A FEATURE OF THE MARK.

A DESIGN OF SAILS IN AN OVAL CIRCLE WITH THE SAILS IN BLUE AND SILVER WITH BLACK OUTLINES. THE WORDING "SILVER SAILS" IS DIRECTLY BELOW THE DESIGN AND IN SILVER WITH AN UNDERLINE ALSO IN SILVER.

FOR COATING COMPOSITIONS IN THE NATURE OF PAINT FOR INDUSTRIAL APPLICATIONS (U.S. CLS. 6, 11 AND 16).

CURTIS FRENCH, EXAMINING ATTORNEY

SN 85-286,486. JOVIAL INC., DBA SILVER SAILS PAINTS, RIVER VALE, NJ. FILED 4-5-2011.



THE COLOR(S) BLUE, SILVER, AND WHITE IS/ARE CLAIMED AS A FEATURE OF THE MARK.

A DESIGN OF SAILS IN AN OVAL CIRCLE WITH THE SAILS IN WHITE AND SILVER ON A BLUE OVAL WITH A SILVER BORDER. THE WORDING "YINYAN" IS DIRECTLY BELOW THE DESIGN AND IN SILVER.

THE ENGLISH TRANSLATION OF THE WORD "YINFAN" IN THE MARK IS "SILVER SAILS".

FOR COATING COMPOSITIONS IN THE NATURE OF PAINT CONTAINING THERMOSETTING RESINS AND THERMOPLASTIC RESINS USED TO COAT METAL PRODUCTS, FOR INDUSTRIAL APPLICATIONS (U.S. CLS. 6, 11 AND 16).

CURTIS FRENCH, EXAMINING ATTORNEY

CLASS 2—(Continued).

SN 85-291,253. SCHIEFELBEIN, DAN, ORANGE, CA. FILED 4-11-2011.

LEVEL WALL-5

THE MARK CONSISTS OF STANDARD CHARACTERS WITHOUT CLAIM TO ANY PARTICULAR FONT, STYLE, SIZE, OR COLOR.

FOR BACTERICIDAL PAINTS (U.S. CLS. 6, 11 AND 16).

FIRST USE 12-1-2010; IN COMMERCE 12-1-2010.
CAROLYN CATALDO, EXAMINING ATTORNEY

SN 85-294,239. SEYMOUR OF SYCAMORE, INC., SYCAMORE, IL. FILED 4-13-2011.

PERMATURF

THE MARK CONSISTS OF STANDARD CHARACTERS WITHOUT CLAIM TO ANY PARTICULAR FONT, STYLE, SIZE, OR COLOR.

FOR LONG LASTING PAINT USED TO MARK SYNTHETIC FIELD SURFACES (U.S. CLS. 6, 11 AND 16).

NELSON SNYDER, EXAMINING ATTORNEY

SN 85-307,389. AKZO NOBEL COATINGS INTERNATIONAL B.V., ARNHEM, NETHERLANDS, FILED 4-28-2011.

SPEED-COTE

THE MARK CONSISTS OF STANDARD CHARACTERS WITHOUT CLAIM TO ANY PARTICULAR FONT, STYLE, SIZE, OR COLOR.

FOR PAINT (U.S. CLS. 6, 11 AND 16).
FIRST USE 5-8-2000; IN COMMERCE 5-8-2000.
JOHN WILKE, EXAMINING ATTORNEY

CLASS 3—COSMETICS AND CLEANING PREPARATIONS

SN 76-700,387. TEMPTU, INC., NEW YORK, NY. FILED 11-16-2009.



THE MARK CONSISTS OF A TWO DIMENSIONAL ART-WORK WITH AN OVAL OR TEAR DROP SHAPE WITH ANOTHER HOLLOW TEAR DROP SHAPE IN THE CENTER.

FOR COSMETICS (U.S. CLS. 1, 4, 6, 50, 51 AND 52).
FIRST USE 7-1-2009; IN COMMERCE 8-1-2009.
TINA L. SNAPP, EXAMINING ATTORNEY

SN 76-704,915. LOUDER, MARY, TRAVERSE CITY, MI. FILED 10-15-2010.

SERE BELLESA

THE MARK CONSISTS OF STANDARD CHARACTERS WITHOUT CLAIM TO ANY PARTICULAR FONT, STYLE, SIZE, OR COLOR.

THE ENGLISH TRANSLATION OF THE WORD "SERE" IN THE MARK IS "EVENINGS".

FOR NON-MEDICATED SKIN CARE PREPARATIONS (U.S. CLS. 1, 4, 6, 50, 51 AND 52).

CARYN GLASSER, EXAMINING ATTORNEY

SN 76-706,543. NORDICO MARKET DEVELOPMENT, INC., DOUGLSTON, NY. FILED 2-24-2011.

TRUE CLEAN

THE MARK CONSISTS OF STANDARD CHARACTERS WITHOUT CLAIM TO ANY PARTICULAR FONT, STYLE, SIZE, OR COLOR.

NO CLAIM IS MADE TO THE EXCLUSIVE RIGHT TO USE "CLEAN", APART FROM THE MARK AS SHOWN.

FOR ALL-PURPOSE CLEANSING DETERGENTS, DEGREASING AND DISINFECTANT PREPARATIONS FOR HARD SURFACES. PRODUCTS TO BE USED FOR SKIN CLEANSING AND ANTISEPSIS, NAMELY, LIQUID SOAPS, FACE LOTIONS, BODY LOTIONS, HAND LOTIONS, SKIN LOTIONS, HAND SOAPS, TOILET SOAPS, DISINFECTANT SOAPS AND FOAM CLEANING PREPARATIONS (U.S. CLS. 1, 4, 6, 50, 51 AND 52).

THOMAS MANOR, EXAMINING ATTORNEY

CLASS 3—(Continued).

SN 77-477,450. IT COSMETICS, LLC, JERSEY CITY, NJ. FILED 5-18-2008.

BOOB JOB

THE MARK CONSISTS OF STANDARD CHARACTERS WITHOUT CLAIM TO ANY PARTICULAR FONT, STYLE, SIZE, OR COLOR.

FOR MAKE-UP FOR THE FACE AND BODY (U.S. CLS. 1, 4, 6, 50, 51 AND 52).

KIMBERLY FRYE, EXAMINING ATTORNEY

SN 77-904,751. WONDER MARKETING, INC., SANTA BARBARA, CA. FILED 1-4-2010.

EARTH CPR

THE MARK CONSISTS OF STANDARD CHARACTERS WITHOUT CLAIM TO ANY PARTICULAR FONT, STYLE, SIZE, OR COLOR.

OWNER OF U.S. REG. NOS. 2,599,607, 3,024,248 AND 3,871,618.

FOR ALL-PURPOSE CLEANERS FOR USE WITH LEATHER, WOOD, METAL, PLASTIC, BRASS, SILVER, COPPER, CHROME, ALUMINUM, FURNITURE, FLOOR, PEWTER, STAINLESS STEEL, ENAMEL, STONE, MARBLE, FIBERGLASS, RUBBER, AUTOMOTIVE, AND VINYL; APPLIANCE CLEANER AND POLISH; CLEANER, POLISH, AND CONDITIONER FOR USE ON METAL; CLEANER, POLISH, AND CONDITIONER FOR USE ON STAINLESS STEEL, BRASS, AND CHROME; MULTIPURPOSE CLEANER, POLISH, AND CONDITIONER FOR HOUSEHOLD, INDUSTRIAL, MARINE, AND INSTITUTIONAL USE ON METAL SURFACES; DISPOSABLE WIPES IMPREGNATED WITH CHEMICALS OR COMPOUNDS FOR CLEANING, PROTECTING, AND POLISHING METAL SURFACES, BBQ GRILLS, HOUSEHOLD SURFACES, AND INTERIOR METAL SURFACES, METAL CLEANER USED TO CLEAN METAL SURFACES AND REMOVE FINGERPRINTS, WATER SPOTS, AND FOOD STAINS, CLEANING AND CONDITIONING PREPARATION FOR USE ON LEATHER AND MAN-MADE MATERIALS; HORSE GROOMING PRODUCTS, NAMELY, COAT BRIGHTENER, MANE AND TAIL WHITENER, SPRAY WHITENER, COAT DRESSING AND CONDITIONER, HOOF CONDITIONERS AND HOOF DRESSING; PREPARATIONS FOR CLEANING, PROTECTING, RESTORING, BRIGHTENING, AND CONDITIONING VINYL, LEATHER, PLASTIC, RUBBER, AND PAINTED AUTOMOBILE SURFACES; POLYMER SEALANTS FOR CLEANING, SHINING, AND PROTECTING AUTOMOBILE EXTERIOR SURFACES; CAR, TIRE, GLASS, AND WHEEL CLEANING PREPARATIONS; AUTOMOBILE WAX AND MULTI-PURPOSE CLEANING PREPARATIONS; NON-MEDICATED GROOMING PREPARATIONS FOR PETS, NAMELY, LOTIONS, CREAMS, AND DEODORANTS; PET STAIN REMOVERS; FABRIC CLEANING PREPARATIONS FOR CARPETS AND FURNITURE; CLEANING PREPARATIONS FOR PETS; PET ODOR REMOVERS; FURNITURE POLISH; MULTIPURPOSE CLEANING AND RECONDITIONING PREPARATIONS FOR WOOD, HOUSEHOLD SURFACES, INTERIOR WOOD SURFACES, AND FLOORS; WOOD CLEANERS AND POLISH FOR HOUSEHOLD, INDUSTRIAL, AND INSTITUTIONAL USE; DISPOSABLE WIPES IMPREGNATED WITH CHEMICALS OR COM-

CLASS 3—(Continued).

POUNDS FOR CLEANING AND POLISHING WOOD, HOUSEHOLD SURFACES, INTERIOR WOOD SURFACES, AND FLOORS; CLEANING AND CONDITIONING PREPARATION FOR USE ON LEATHER AND MAN-MADE MATERIALS; LEATHER CLEANER AND CONDITIONER; PREPARATIONS FOR CLEANING, PROTECTING, RESTORING, TREATING, AND CONDITIONING LEATHER, FURNITURE, CAR SEATS, JACKETS, PURSES, SHOES, SADDLES, EQUINE RELATED GOODS, BOOTS AND MAN-MADE MATERIALS, NAMELY MANMADE LEATHER AND VINYL; LEATHER CLEANER AND CONDITIONER FOR SPORTING GOODS; HOUSE MARK FOR COSMETICS, COSMETICS, BODY AND BEAUTY CARE COSMETICS, BABY AND CHILDREN'S HEALTH AND BEAUTY SKIN CARE PRODUCTS, NAMELY, BODY POWDERS, NON-MEDICATED DIAPER RASH OINTMENTS AND CREAMS; BEDTIME BODY LOTION; BABY WIPES; NAMELY SCENTED BODY SPRAY; BATH AND BODY GELS, BATH BEADS, BATH OIL, BATH SALTS, BLUSH, BODY GLITTER, BODY MIST, BODY OIL, BODY SCRUB, BODY WASH, BUBBLE BATH, BRONZERS; BODY CREAMS, BODY MISTS; BODY SCRUBS; BODY LOTIONS; BODY OILS; BODY SPRAYS; BUBBLE BATH, BATH AND BODY POWDER, BRONZING STICKS, COLD CREAM; COLOGNE, CREAMS, GELS, AND SPRAYS FOR THE FACE AND BODY, CONCEALERS, COSMETICS, COSMETIC CLEANSING CREAMS; COSMETIC CREAMS FOR SKIN CARE; COSMETIC OILS; COSMETIC PREPARATIONS FOR BODY CARE; COSMETIC PRODUCTS IN THE FORM OF AEROSOLS FOR SKINCARE; CUTICLE CREAMS AND CONDITIONERS, DEODORANTS AND ANTI-PERSPIRANTS, EXFOLIATING PREPARATIONS FOR THE SKIN, EYE GELS, EYE MASKS, EYE SHADOW, EYE LINING PENCILS, LIQUID EYE LINERS, EYE MAKEUP, MASCARA, EYEBROW PENCILS, ARTIFICIAL EYELASHES, EYE MAKE-UP REMOVER, ESSENTIAL OILS FOR AROMATHERAPY; ESSENTIAL OILS FOR PERSONAL USE; FACE HIGHLIGHTER, FACE MASKS, FACE MIST, FACE CREAMS FOR COSMETIC USE; FACIAL CLEANSERS; FACIAL CREAMS, FACIAL CLEANSERS, FACIAL MOISTURIZERS, FACIAL SCRUBS, FACIAL TONERS, AND ASTRINGENTS FOR COSMETIC USE; FOAMS CONTAINING COSMETICS AND SUNSCREENS; PERFUMERY AND FRAGRANCES FOR PERSONAL USE, NAMELY, PERFUME, COLOGNES, EAU DE COLOGNE, EAU DE PARFUM, EAU DE TOILETTE, AFTER SHAVE GEL AND AFTER SHAVE LOTION; NON-MEDICATED FOOT SOAKS, FRAGRANT BODY SPLASH, FRAGRANT BODY MIST, FOUNDATION MAKEUP FOR THE FACE AND BODY; LIPSTICK, LIP GLOSS, LIP LINERS, LIP BALMS, NON-MEDICATED SKIN CARE PREPARATIONS, NAMELY, MOISTURIZING LOTIONS AND CREAMS; TONERS; ASTRINGENTS FOR COSMETIC USE; BODY CLEANSERS; SOAPS IN LIQUID, SOLID OR GEL FORM, BODY CREAM SOAP, COSMETIC SOAPS, CREAM SOAPS, HAND SOAPS, LIQUID SOAP, LIQUID SOAPS FOR HANDS, FACE, AND BODY; PERFUMED SOAP, SKIN SOAP, SOAPS FOR BODY CARE, SOAPS FOR PERSONAL USE; FACIAL GELS; FACIAL MOUSSE; NAIL ENAMEL, NAIL POLISH, NAIL HARDENER, NAIL CONDITIONER, NAIL POLISH REMOVER, HAND AND NAIL CARE PREPARATIONS, NAMELY, HAND CREAMS AND LOTIONS, NAIL CREAMS, CUTICLE CREAMS AND CUTICLE CONDITIONERS; NON-MEDICATED FOOT CREAMS AND POWDERS; AGE SPOT REDUCING CREAMS; EYE MAKEUP REMOVER; AROMATHERAPY CREAMS AND OILS; EYE CREAMS; BEAUTY MASKS; SKIN EXFOLIATING CREAM; SALT SCRUBS FOR THE SKIN, SHAVING CREAM, SHAVING GELS, SHOWER CREAM, SHOWER GEL, SKIN BRONZING CREAM, SOAP FOR THE BODY, SOAP FOR THE FACE, SOAP FOR THE HANDS, AND TALCUM POWDER, SKIN EXFOLIANTS; SKIN CLEANSING BARS; LIP CREAMS; MAKE UP REMOVING PREPARATIONS; SUN CARE PRODUCTS, NAMELY, SUN SCREEN, SUN BLOCK, SUN TANNING PREPARATIONS, SUNLESS TANNING LOTION, PRE-SUNTANNING LOTION, POST-SUNTANNING LOTION, AND SELF-TANNING CREAMS, BLEACHING PREPARATIONS AND OTHER SUBSTANCES FOR LAUNDRY USE; CLEANING, POLISHING, SCOURING AND ABRASIVE PREPARATIONS; PREPARATIONS FOR CLEANING THE TEETH, MOUTH WASHES, DENTIFRICES; COSMETIC PADS; CLEANING, POLISHING, SCOURING AND ABRASIVE PREPARATIONS FOR

CLASS 3—(Continued).

HOUSEHOLD USE; LAUNDRY POWDERS; SHOE WAXES AND CREAMS; LEATHER CARE PRODUCTS, NAMELY, PREPARATIONS FOR POLISHING, CLEANING, AND CONDITIONING LEATHER GOODS; BARBECUE GRILL CLEANING PREPARATIONS; BARBECUE CLEANERS AND DEGREASERS; CLEANING PREPARATIONS, NAMELY ALL PURPOSE CLEANER AND DEGREASER, GRILL AND OVEN CLEANER, STAINLESS STEEL CLEANER, STAINLESS STEEL POLISH AND DETARNISHER; PREPARATIONS FOR CLEANING OVENS AND BARBECUE GRILLS; ALL-PURPOSE CLEANER; CLEANER, POLISH, AND CONDITIONER FOR USE ON STONE, GRANITE AND MARBLE; MULTIPURPOSE CLEANER, POLISH, AND CONDITIONER FOR HOUSEHOLD, INDUSTRIAL, AND INSTITUTIONAL USE ON STONE, GRANITE AND MARBLE SURFACES; CARPET CLEANING PREPARATIONS, CLEANING AND CONDITIONING PREPARATIONS FOR HOUSEHOLD PURPOSES (U.S. CLS. 1, 4, 6, 50, 51 AND 52).

REGINA DRUMMOND, EXAMINING ATTORNEY

SN 77-955,499. AUSTRALIAN GOLD, LLC, INDIANAPOLIS, IN. FILED 3-10-2010.

HD POSH

THE MARK CONSISTS OF STANDARD CHARACTERS WITHOUT CLAIM TO ANY PARTICULAR FONT, STYLE, SIZE, OR COLOR.

FOR NON-MEDICATED INDOOR AND OUTDOOR SKIN TANNING PREPARATIONS (U.S. CLS. 1, 4, 6, 50, 51 AND 52).

ANGELA M. MICHELI, EXAMINING ATTORNEY

SN 77-965,832. LINMAR TECHNOLOGY INC., BROOKLYN, NY. FILED 3-23-2010.

MAGICLEAR

THE MARK CONSISTS OF THE WORD "MAGICLEAR" WITH A HORIZONTAL LINE APPEARING ABOVE THE LETTERS "MAGIC" IN THE MARK, AND A HORIZONTAL LINE APPEARING BELOW THE LETTERS "CLEAR" IN THE MARK.

FOR CONCENTRATE USED FOR CLEANING WINDSHIELDS AND WIPER BLADES (U.S. CLS. 1, 4, 6, 50, 51 AND 52).

ANTHONY RINKER, EXAMINING ATTORNEY

CLASS 3—(Continued).

SN 78-307,171. GEORGIA-PACIFIC CONSUMER PRODUCTS LP, ATLANTA, GA. FILED 9-30-2003.

BRAWNY

OWNER OF U.S. REG. NOS. 1,062,207, 2,766,328 AND OTHERS.
FOR PRE-MOISTENED HAND AND FACIAL WIPES (U.S. CLS. 1, 4, 6, 50, 51 AND 52).
FIRST USE 3-10-2003; IN COMMERCE 3-10-2003.
BRIAN PINO, EXAMINING ATTORNEY

SN 78-788,674. UAN'S INTERNATIONAL INC., RICHMOND HILL, ONTARIO, CANADA, FILED 1-10-2006.

UANS

THE MARK CONSISTS OF STANDARD CHARACTERS WITHOUT CLAIM TO ANY PARTICULAR FONT, STYLE, SIZE, OR COLOR.

PRIORITY CLAIMED UNDER SEC. 44(D) ON CANADA APPLICATION NO. 1283971, FILED 12-21-2005, REG. NO. TMA782392, DATED 11-15-2010, EXPIRES 11-15-2025.

OWNER OF U.S. REG. NOS. 1,450,265 AND 1,805,694.
FOR HAIR CARE AND TREATMENT PRODUCTS, NAMELY, SHAMPOO, RINSE, CONDITIONER, LOTION, SPRAY, COLOUR, BLEACH, PEROXIDE, HAIR PERMANENT WAVING COMPOSITION AND STRAIGHTENING COMPOSITION (U.S. CLS. 1, 4, 6, 50, 51 AND 52).
WILLIAM P. SHANAHAN, EXAMINING ATTORNEY

CLASS 3—(Continued).

SN 79-084,511. BIOPHA, FRANCE, FILED 6-11-2010.

BIOPHA

THE MARK CONSISTS OF STANDARD CHARACTERS WITHOUT CLAIM TO ANY PARTICULAR FONT, STYLE, SIZE, OR COLOR.

OWNER OF INTERNATIONAL REGISTRATION 1043822 DATED 6-11-2010, EXPIRES 6-11-2020.

THE WORDING "BIOPHA" HAS NO MEANING IN A FOREIGN LANGUAGE.

FOR HYGIENIC, BEAUTY, TOILETRY AND CARE PREPARATIONS, NAMELY, NON-MEDICATED FEMINE HYGIENE WASH, BEAUTY CREAMS, CLEANSING MILK FOR TOILET PURPOSES, BEAUTY CREAMS FOR BODY CARE; PERFUMERY, BASES FOR FLOWER PERFUMES AND FOR PLANT PERFUMES, NAMELY, ESSENTIAL OILS FOR PERFUMES; SOAPS, NAMELY, BODY SOAPS, BATH SOAP, FACE SOAPS, BAR SOAP, GEL SOAP, LIQUID SOAP; PROTECTIVE CREAMS FOR CHANGING BABIES' DIAPERS, NAMELY, NON-MEDICATED DIAPER RASH CREAM; NON-MEDICATED BODY BALMS FOR TANNING, FOR SHAVING, FOR SKIN MOISTURIZING; COSMETIC SKIN CARE PREPARATIONS FOR CLEANING, NOURISHING, MOISTURIZING AND TREATING SKIN FOR MEN, WOMEN AND CHILDREN; COSMETIC CREAMS FOR THE FACE, THE CONTOURS OF THE EYES, THE BODY, THE HANDS, THE NECK AND THE UPPER CHEST; CLEANSING MILKS, LOTIONS, GELS FOR TOILET PURPOSES; COSMETIC SUN-TANNING AND SUNSCREEN PREPARATIONS; ENERGIZING WATERS FOR THE BODY, NAMELY, SCENTED LINEN WATER; TOILET WATER; OILS FOR TOILET PURPOSES, ALMOND OIL BEING ESSENTIAL OILS NOT FOR MEDICAL USE (U.S. CLS. 1, 4, 6, 50, 51 AND 52).

MYRIAH HABEEB, EXAMINING ATTORNEY

SN 79-084,807. BIOPHA, FRANCE, FILED 6-11-2010.

BIO SECURE DE BIOPHA

THE MARK CONSISTS OF STANDARD CHARACTERS WITHOUT CLAIM TO ANY PARTICULAR FONT, STYLE, SIZE, OR COLOR.

OWNER OF INTERNATIONAL REGISTRATION 1044532 DATED 6-11-2010, EXPIRES 6-11-2020.

THE ENGLISH TRANSLATION OF "DE BIOPHA" IN THE MARK IS "BY BIOPHA". THE WORDING "BIOPHA" HAS NO MEANING IN A FOREIGN LANGUAGE.

FOR HYGIENIC, BEAUTY, TOILETRY AND CARE PREPARATIONS, NAMELY, NON-MEDICATED FEMINE HYGIENE WASH, BEAUTY CREAMS, CLEANSING MILK FOR TOILET PURPOSES, BEAUTY CREAMS FOR BODY CARE; PERFUMERY, BASES FOR FLOWER PERFUMES AND FOR PLANT PERFUMES, NAMELY, ESSENTIAL OILS FOR PERFUMES; SOAPS, NAMELY, BODY SOAPS, BATH SOAP, FACE SOAPS, BAR SOAP, GEL SOAP, LIQUID SOAP; PROTECTIVE CREAMS FOR CHANGING BABIES' DIAPERS, NAMELY, NON-MEDICATED DIAPER RASH CREAM; NON-MEDICATED BODY BALMS FOR TANNING, FOR SHAVING, FOR SKIN MOISTURIZING; COSMETIC SKIN CARE PREPARATIONS FOR CLEANING, NOURISHING, MOISTURIZING AND TREATING SKIN FOR MEN, WOMEN AND CHILDREN; COSMETIC CREAMS FOR THE FACE, THE CONTOURS OF THE EYES, THE BODY, THE HANDS, THE NECK AND THE UPPER CHEST; CLEANSING MILKS, LOTIONS, GELS FOR TOILET PURPOSES; COSMETIC SUN-TANNING AND SUNSCREEN PREPARATIONS; ENERGIZING WATERS FOR THE BODY, NAMELY, SCENTED LINEN WATER; TOILET WATER; OILS FOR TOILET PURPOSES, ALMOND OIL BEING ESSENTIAL OILS NOT FOR MEDICAL USE (U.S. CLS. 1, 4, 6, 50, 51 AND 52).

MYRIAH HABEEB, EXAMINING ATTORNEY

CLASS 3—(Continued).

SN 79-090,778. BARTEL, BORIS, FED REP GERMANY, FILED 10-28-2010.

BB ROYAL

THE MARK CONSISTS OF STANDARD CHARACTERS WITHOUT CLAIM TO ANY PARTICULAR FONT, STYLE, SIZE, OR COLOR.

PRIORITY DATE OF 5-20-2010 IS CLAIMED.

OWNER OF INTERNATIONAL REGISTRATION 1060586 DATED 10-28-2010, EXPIRES 10-28-2020.

THE WORDING "BB" HAS NO MEANING IN A FOREIGN LANGUAGE.

FOR BLEACHING PREPARATIONS FOR COSMETIC PURPOSES; BLEACHING PREPARATIONS FOR HOUSEHOLD PURPOSES; FURBISHING PREPARATIONS, NAMELY GENERAL PURPOSE POLISHING LIQUIDS, POLISHING AGENTS BEING POLISHING PREPARATIONS, DEGREASERS NOT USED IN MANUFACTURING PROCESSES FOR MACHINES AND ABRASIVE PREPARATIONS FOR HOUSEHOLD PURPOSES; SOAPS, NAMELY BATH SOAP AND BODY SOAP; PERFUMERY, ETHEREAL OILS, COSMETICS, HAIR LOTIONS; DENTIFRICES; MAKE-UP REMOVING PREPARATIONS; COSMETICS PREPARATIONS FOR BATHS; SUN-TANNING PREPARATIONS BEING COSMETICS; LOTIONS FOR COSMETIC PURPOSES; OILS FOR CLEANING PURPOSES; SUNSCREENS AND SUN COSMETICS FOR USE IN NATURAL SUN; SUNSCREENS AND SUN COSMETICS FOR USE IN ARTIFICIAL SUN, ESPECIALLY FOR USE IN SOLARIA AND SUN BEDS; LAUNDRY BLEACH; POLISHING PREPARATIONS; BATH SOAP; BODY SOAP; ASTRINGENTS FOR COSMETIC PURPOSES; AMBER BEING PERFUME; BREATH FRESHENING SPRAYS; ETHEREAL ESSENCES; EYEBROW COSMETICS; EYEBROW PENCILS; SOAP FOR BRIGHTENING TEXTILE; BATH SALTS, NOT FOR MEDICAL PURPOSES; COSMETIC PREPARATIONS FOR BATHS; SKIN WHITENING CREAMS; BLEACHING PREPARATIONS BEING DECOLORANTS FOR COSMETIC PURPOSES; DEODORANTS FOR PERSONAL USE; DEODORANT SOAP; SCENTED LINEN WATER; COLORANTS FOR TOILET PURPOSES FOR HAIR; COSMETIC HAIR DYES; GREASES FOR COSMETIC PURPOSES; HAIR DYES; HAIR SPRAY; SHAMPOOS; SUN-TANNING PREPARATIONS BEING COSMETICS; COSMETIC PENCILS; COSMETIC CREAMS; COSMETIC PREPARATIONS FOR SKIN CARE; DECORATIVE TRANSFERS FOR COSMETIC PURPOSES; FALSE NAILS; FALSE EYELASHES; LIPSTICKS; MAKE-UP; MOISTURIZING ALMOND MILK FOR COSMETIC PURPOSES; COSMETIC ALMOND OIL; ALMOND SOAP; MASSAGE GEL, OTHER THAN FOR MEDICAL PURPOSES; MOUTH WASHES, NOT FOR MEDICAL PURPOSES; NAIL VARNISH; NAIL CARE PREPARATIONS; OILS FOR TOILET PURPOSES; OILS FOR COSMETIC PURPOSES; OILS FOR PERFUMES AND SCENTS; PERFUMES; AFTER-SHAVE LOTIONS; CLEANING MILK FOR TOILET PURPOSES; COSMETIC PREPARATIONS FOR SLIMMING PURPOSES; MAKE-UP PREPARATIONS; MAKE-UP POWDER; BEAUTY MASKS; ANTI-PERSPIRANT SOAP; SUN-TANNING PREPARATIONS FOR NATURAL SUN; SUN-TANNING PREPARATIONS FOR ARTIFICIAL SUN, ESPECIALLY FOR SOLARIUMS; NON-MEDICATED TOILETRIES; CAKES OF TOILET SOAP; TOILET WATER; TISSUES IMPREGNATED WITH COSMETIC LOTIONS; PETROLEUM JELLY FOR COSMETIC PURPOSES; HYDROGEN PEROXIDE FOR COSMETIC PURPOSES, NAMELY FOR USE ON THE HAIR; COTTON WOOL FOR COSMETIC PURPOSES; COTTON SWABS BEING TOILETRIES; COSMETIC PREPARATIONS FOR EYELASHES; MASCARA (U.S. CLS. 1, 4, 6, 50, 51 AND 52).

MYRIAH HABEEB, EXAMINING ATTORNEY

CLASS 3—(Continued).

SN 79-093,944. HJC, FRANCE, FILED 12-8-2010.

OWNER OF INTERNATIONAL REGISTRATION 0557233 DATED 7-10-1990, EXPIRES 7-10-2020.

FOR SOAPS, PERFUMERY, ESSENTIAL OILS, COSMETICS, HAIR LOTIONS; DENTIFRICES (U.S. CLS. 1, 4, 6, 50, 51 AND 52).

JOHN WILKE, EXAMINING ATTORNEY

SN 85-035,528. PERFECT SCIENCE LABS, LLC, BEVERLY HILLS, CA. FILED 5-11-2010.

PERFECTAN

THE MARK CONSISTS OF STANDARD CHARACTERS WITHOUT CLAIM TO ANY PARTICULAR FONT, STYLE, SIZE, OR COLOR.

FOR PERSONAL CARE PRODUCTS, NAMELY, BODY BALM, BODY SOAP BAR, BODY BUTTER, BODY CREAM, BODY ESSENCE IN THE NATURE OF A BODY SPRAY WITH A FRAGRANCE, BODY GEL, BODY GLITTER, BODY LOTION, BODY MASK, BODY MIST, BODY OIL, BODY PAINT, BODY POWDER, BODY SCRUB, BODY SMOOTHER, BODY SOAP, BODY SPLASH, BODY WASH, BUFFING BAR, COLOGNE, EYE SUNSCREEN BLOCK, EYE CREAM, EYE GEL, EYE MASK, EYE REPAIR CREAM, FACE BALM, FACE BLOCK, FACE CLEANSER, FACE CREAM, FACE GEL, FACE LOTION, FACE MASK, FACE MIST SPRAY, FACE MOISTURIZER, HAIR CONDITIONER, HAIR GEL, HAIR GLITTER, HAIR POMADE, HAIR REMOVING CREAM, HAIR REPAIR LOTION, HAIR RINSE, HAIR SHAMPOO, HAIR SHINE SERUM, HAIR SPRAY, HAIR STRAIGHTENING CREAM, HAIR STYLING MOUSSE, HAND BALM, HAND CREAM, HAND LOTION, LEG BRONZING CREAM, LINE PREVENTION CONCENTRATE, LINE PREVENTION SERUM, LINE REDUCING CONCENTRATE, LINE REDUCING SERUM, LIP BALM, LIP BLOCK, LIP GLOSS, LIP PAINT, NON-MEDICATED LIP PROTECTOR BALM, LIP SHINE, LIP TINT, NIGHT EYE CREAM, NIGHT NOURISHING SKIN CREAM, OIL BLOTTING SHEETS FOR THE SKIN, OIL BODY SPRAY, POST-SUNTANNING LOTION FOR THE BODY, POTPOURRI, PRE-SUNTANNING LOTION FOR THE BODY, ROOM FRAGRANCE SPRAY, SACHETS, SELF TANNING LOTION, SHEA BUTTER HAND CREAM, SHEA BUTTER CREAM TREATMENT STICK, SHOWER GEL, SKIN BRONZING CREAM, NON-MEDICATED SKIN CLEANSING WIPES, SKIN CREAM, SKIN EXFOLIATING CREAM, SKIN LOTION, SKIN MOISTURIZER, SKIN POLISHER, SKIN SCRUB, SKIN SMOOTHING OIL, LIQUID AND BAR SOAP, HAIR STYLING FOAM, SUN SCREEN, SUNBLOCK FOR THE BODY, SUNBLOCK FOR THE FACE, SUNLESS TANNING CREAM, SUNLESS TANNING LOTION FOR THE BODY, SUNLESS TANNING LOTION FOR THE FACE, SUNTAN LOTION FOR THE BODY, SUNTAN LOTION FOR THE FACE (U.S. CLS. 1, 4, 6, 50, 51 AND 52).

BRIAN PINO, EXAMINING ATTORNEY

CLASS 3—(Continued).

SN 85-071,823. SYDROB, INC., BEVERLY HILLS, CA. FILED 6-25-2010.

DR. REY

THE MARK CONSISTS OF STANDARD CHARACTERS WITHOUT CLAIM TO ANY PARTICULAR FONT, STYLE, SIZE, OR COLOR.

OWNER OF U.S. REG. NOS. 3,596,736 AND 3,666,303.

THE NAME(S), PORTRAIT(S), AND/OR SIGNATURE(S) SHOWN IN THE MARK IDENTIFIES ROBERT REY, WHOSE CONSENT(S) TO REGISTER IS MADE OF RECORD.

FOR COSMETICS AND BODY AND BEAUTY CARE PRODUCTS, NAMELY, CLEANSING CREAMS, CONCEALERS, COSMETIC CREAMS, COSMETIC PREPARATIONS FOR SKIN RENEWAL, COSMETIC PREPARATIONS FOR BODY CARE, MAKE-UP FOUNDATION, MAKE-UP PENCILS, EYE MAKE-UP, LIP GLOSS, FACE CREAMS, SKIN TONERS, MAKE-UP FOR THE FACE AND BODY, ANTI-AGING CREAMS, ANTI-WRINKLE CREAMS, LIP PLUMPER CREAM (U.S. CLS. 1, 4, 6, 50, 51 AND 52).

KIM SAITO, EXAMINING ATTORNEY

SN 85-092,025. DALLI-WERKE GMBH & CO. KG, STOLBERG, FED REP GERMANY, FILED 7-23-2010.

SKIN VALUES

THE MARK CONSISTS OF STANDARD CHARACTERS WITHOUT CLAIM TO ANY PARTICULAR FONT, STYLE, SIZE, OR COLOR.

NO CLAIM IS MADE TO THE EXCLUSIVE RIGHT TO USE "SKIN", APART FROM THE MARK AS SHOWN.

FOR NON-MEDICATED SKIN CARE PREPARATIONS; PRE-MOISTENED COSMETIC WIPES; SKIN CARE BOOSTERS, NAMELY, NON-MEDICATED SKIN CARE PREPARATIONS FOR TREATMENT OF A VARIETY OF SKIN CONDITIONS; NON-MEDICATED ACNE TREATMENT PREPARATIONS; SKIN CARE PRODUCTS, NAMELY, CLEANSING CREAMS, CLEANSING BARS, FACIAL SOAPS, FACIAL MOISTURE AND REVITALIZING MASKS, TONERS, SHAVE CREAMS, SHAVING FOAM AND AFTERSHAVE LOTIONS, MOISTURIZERS, LOTIONS, OIL ABSORBERS, NAMELY, NON-MEDICATED GELS, LOTIONS AND CREAMS AND TISSUES IMPREGNATED WITH NON-MEDICATED SKIN CARE PREPARATIONS TO ABSORB EXCESS OIL ON THE SKIN, SCRUBS, GELS, HAND CREAMS, CLEANERS AND PEELS, CREAM AND LIQUID FOUNDATIONS, MAKE-UP REMOVERS; EXFOLIANTS FOR THE SKIN; COSMETICS (U.S. CLS. 1, 4, 6, 50, 51 AND 52).

RICHARD WHITE, EXAMINING ATTORNEY

CLASS 3—(Continued).

SN 85-092,031. DALLI-WERKE GMBH & CO. KG, STOLBERG, FED REP GERMANY, FILED 7-23-2010.

SKIN UNIVERSALS

THE MARK CONSISTS OF STANDARD CHARACTERS WITHOUT CLAIM TO ANY PARTICULAR FONT, STYLE, SIZE, OR COLOR.

NO CLAIM IS MADE TO THE EXCLUSIVE RIGHT TO USE "SKIN", APART FROM THE MARK AS SHOWN.

FOR NON-MEDICATED SKIN CARE PREPARATIONS; PRE-MOISTENED COSMETIC WIPES; SKIN CARE BOOSTERS, NAMELY, NON-MEDICATED SKIN CARE PREPARATIONS FOR TREATMENT OF A VARIETY OF SKIN CONDITIONS; NON-MEDICATED ACNE TREATMENT PREPARATIONS; SKIN CARE PRODUCTS, NAMELY, CLEANSING CREAMS, CLEANSING BARS, FACIAL SOAPS, FACIAL MOISTURE AND REVITALIZING MASKS, TONERS, SHAVE CREAMS, SHAVING FOAM AND AFTERSHAVE LOTIONS, MOISTURIZERS, LOTIONS, OIL ABSORBERS, NAMELY, NON-MEDICATED GELS, LOTIONS AND CREAMS AND TISSUES IMPREGNATED WITH NON-MEDICATED SKIN CARE PREPARATIONS TO ABSORB EXCESS OIL ON THE SKIN, SCRUBS, GELS, HAND CREAMS, CLEANERS AND PEELS, CREAM AND LIQUID FOUNDATIONS, MAKE-UP REMOVERS; EXFOLIANTS FOR THE SKIN; COSMETICS (U.S. CLS. 1, 4, 6, 50, 51 AND 52).

WILLIAM ROSSMAN, EXAMINING ATTORNEY

SN 85-108,183. IDEAVILLAGE PRODUCTS CORP., WAYNE, NJ. FILED 8-16-2010.

SEXY LEGS

THE MARK CONSISTS OF STANDARD CHARACTERS WITHOUT CLAIM TO ANY PARTICULAR FONT, STYLE, SIZE, OR COLOR.

NO CLAIM IS MADE TO THE EXCLUSIVE RIGHT TO USE "LEGS", APART FROM THE MARK AS SHOWN.

FOR COSMETICS; NON-MEDICATED SKIN CREAMS; TOPICAL SKIN SPRAYS FOR COSMETIC PURPOSES; MAKE-UP (U.S. CLS. 1, 4, 6, 50, 51 AND 52).

RAMONA ORTIGA, EXAMINING ATTORNEY

CLASS 3—(Continued).

SN 85-116,459. INTELLIGENT NUTRIENTS, LLC, MINNEAPOLIS, MN. FILED 8-26-2010.

**INTELLIGENT NUTRIENTS
PLANT STEM CELL SCIENCE**

THE MARK CONSISTS OF STANDARD CHARACTERS WITHOUT CLAIM TO ANY PARTICULAR FONT, STYLE, SIZE, OR COLOR.

OWNER OF U.S. REG. NOS. 3,161,714, 3,867,492 AND OTHERS.

NO CLAIM IS MADE TO THE EXCLUSIVE RIGHT TO USE "NUTRIENTS PLANT STEM CELL SCIENCE", APART FROM THE MARK AS SHOWN.

FOR HAIR CARE PRODUCTS, NAMELY, SHAMPOOS, CONDITIONERS, SPRAY AND SCULPTING GELS, HAIR COLOR, AND WAVING LOTIONS; NON-MEDICATED SKIN CARE PRODUCTS, NAMELY, MOISTURIZERS, TONERS, SKIN CLEANING CREAMS, LUBRICANTS, BODY AND FACIAL LOTIONS AND GELS, MASKS AND ASTRINGENTS; COSMETICS, NAMELY, LIPSTICK, EYE SHADOW, FOUNDATION, BLUSH, FACE POWDER, CONCEALER, EYE PENCILS, LIP PENCILS AND MASCARA; NON-MEDICATED PERSONAL HYGIENE PRODUCTS, NAMELY, CLEANSERS, GELS, FRAGRANCES, OILS AND LOTIONS, SKIN CREAMS, SKIN LOTIONS, SKIN EMOLLIENTS, MOISTURIZING OILS AND LOTIONS; PERFUMES AND COLOGNES; INCENSE AND ROOM FRAGRANCES; AROMATHERAPY ESSENTIAL OILS AND SCENTED ESSENTIAL OILS THAT ARE USED AND/OR DISTRIBUTED INTO THE AIR THROUGH THE USE OF AROMATHERAPY PRODUCTS AND AIR DIFFUSERS; NON-MEDICATED HAIR CARE, SKIN CARE AND PERSONAL HYGIENE PRODUCTS, NAMELY, SHAMPOO, CONDITIONER, BABY WIPES, MOISTURIZERS, LOTIONS, COSMETICS, CLEANSERS, SKIN CREAMS AND PERFUMES AND COLOGNES FOR BABIES AND PREGNANT WOMEN (U.S. CLS. 1, 4, 6, 50, 51 AND 52).
LAURIE KAUFMAN, EXAMINING ATTORNEY

SN 85-120,134. SAVVIER, L.P., CARLSBAD, CA. FILED 8-31-2010.

LIGHTNING WHITE

THE MARK CONSISTS OF STANDARD CHARACTERS WITHOUT CLAIM TO ANY PARTICULAR FONT, STYLE, SIZE, OR COLOR.

NO CLAIM IS MADE TO THE EXCLUSIVE RIGHT TO USE "WHITE", APART FROM THE MARK AS SHOWN.

FOR TEETH WHITENING KIT (U.S. CLS. 1, 4, 6, 50, 51 AND 52).

HOWARD FRIEDMAN, EXAMINING ATTORNEY

CLASS 3—(Continued).

SN 85-126,854. MO INDUSTRIES, LLC, LOS ANGELES, CA. FILED 9-10-2010.

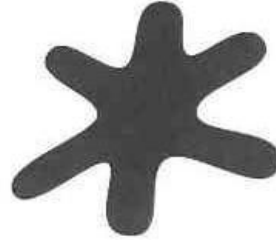

THE MARK CONSISTS OF AN IMAGE OF AN IRREGULAR STYLIZED ASTERISK OR STAR.

FOR SOAPS, PERFUMERY, ESSENTIAL OILS FOR PERSONAL USE, ESSENTIAL OILS FOR HOUSEHOLD USE, COSMETICS, HAIR LOTIONS, BODY LOTIONS, BODY WASH FOR HUMANS, BODY BUTTERS, NON-MEDICATED SKIN CARE PREPARATIONS, NAMELY, BODY AND FACIAL MISTS, BUBBLE BATH, HOME FRAGRANCE SPRAYS, NAMELY, ROOM FRAGRANCES, HOME FRAGRANCE STICKS, NAMELY, INCENSE STICKS, POTPOURRI (U.S. CLS. 1, 4, 6, 50, 51 AND 52).

CURTIS FRENCH, EXAMINING ATTORNEY

SN 85-127,281. FRAGRANCE MARKETING GROUP, LLC, EDEN PRAIRIE, MN. FILED 9-10-2010.

NATURAL INSPIRATIONS

THE MARK CONSISTS OF STANDARD CHARACTERS WITHOUT CLAIM TO ANY PARTICULAR FONT, STYLE, SIZE, OR COLOR.

NO CLAIM IS MADE TO THE EXCLUSIVE RIGHT TO USE "NATURAL", APART FROM THE MARK AS SHOWN.

FOR BATH AND BODY CARE PRODUCTS, NAMELY, BODY LOTION, BODY BUTTER, SHOWER GEL, SOAP, LIP BALM; HAIR CARE PREPARATIONS; SHAMPOO; NON-MEDICATED SKIN CARE PREPARATIONS; NON-MEDICATED COSMETIC TOWELETTES (U.S. CLS. 1, 4, 6, 50, 51 AND 52).

JILL PRATER, EXAMINING ATTORNEY

CLASS 3—(Continued).

SN 85-128,636. IT COSMETICS, JERSEY CITY, NJ. FILED 9-13-2010.

Grow-Luxe

THE MARK CONSISTS OF STANDARD CHARACTERS WITHOUT CLAIM TO ANY PARTICULAR FONT, STYLE, SIZE, OR COLOR.

FOR CHEMICAL INGREDIENTS BEING A FEATURE OF COSMETIC HAIR FILLING POWDERS FOR COVERING BALD AND THINNING SPOTS ON THE SCALP; CHEMICAL INGREDIENTS BEING A FEATURE OF COSMETIC PENCILS; CHEMICAL INGREDIENTS BEING A FEATURE OF COSMETIC PREPARATIONS; CHEMICAL INGREDIENTS BEING A FEATURE OF COSMETIC PREPARATIONS FOR THE HAIR AND SCALP; CHEMICAL INGREDIENTS BEING A FEATURE OF COSMETICS; CHEMICAL INGREDIENTS BEING A FEATURE OF COSMETICS AND COSMETIC PREPARATIONS; CHEMICAL INGREDIENTS BEING A FEATURE OF COSMETICS AND MAKE-UP; CHEMICAL INGREDIENTS BEING A FEATURE OF EYEBROW COSMETICS; CHEMICAL INGREDIENTS BEING A FEATURE OF NON-MEDICATED HAIR TREATMENT PREPARATIONS FOR COSMETIC PURPOSES; CHEMICAL INGREDIENTS BEING A FEATURE OF OILS FOR COSMETIC PURPOSES; CHEMICAL INGREDIENTS BEING A FEATURE OF PENCILS FOR COSMETIC PURPOSES (U.S. CLS. 1, 4, 6, 50, 51 AND 52).

FIRST USE 6-1-2010; IN COMMERCE 6-15-2010.

NICHOLAS COLEMAN, EXAMINING ATTORNEY

SN 85-131,134. TWENTY ONE TEN, INC., FAYETTEVILLE, NC. FILED 9-16-2010.

TWENTY ONE 10

THE MARK CONSISTS OF STANDARD CHARACTERS WITHOUT CLAIM TO ANY PARTICULAR FONT, STYLE, SIZE, OR COLOR.

FOR PERSONAL CARE PRODUCTS, NAMELY, SHAMPOO AND CONDITIONER, NAIL PRODUCTS IN THE NATURE OF FALSE NAILS, AND HARDENERS, GELS, CONDITIONERS, DRYING PREPARATIONS, CREAMS, AND CLEANSERS FOR NAILS (U.S. CLS. 1, 4, 6, 50, 51 AND 52).

ANTHONY RINKER, EXAMINING ATTORNEY

CLASS 3—(Continued).

SN 85-135,153. INTELLECTUAL PROPERTY DEVELOPMENT CORPORATION PTY LTD, MELBOURNE, AUSTRALIA, FILED 9-22-2010.

HOSPITAL PLUS

THE MARK CONSISTS OF STANDARD CHARACTERS WITHOUT CLAIM TO ANY PARTICULAR FONT, STYLE, SIZE, OR COLOR.

OWNER OF AUSTRALIA REG. NO. 1352168, DATED 3-23-2010, EXPIRES 3-23-2020.

NO CLAIM IS MADE TO THE EXCLUSIVE RIGHT TO USE "HOSPITAL", APART FROM THE MARK AS SHOWN.

FOR BLEACHING PREPARATIONS FOR LAUNDRY USE; CLEANING, POLISHING, SCOURING AND ABRASIVE PREPARATIONS EXCLUDING PREPARATIONS FOR THE HAIR; SOAPS; PERFUMERY, ESSENTIAL OILS EXCLUDING PREPARATIONS FOR THE HAIR, COSMETICS; HAIR LOTIONS; DENTIFRICES; PREPARATIONS FOR WINDOW CLEANING; WINDOW CLEANERS IN THE NATURE OF WINDOW POLISH IN SPRAY FORM; GLASS CLEANING PREPARATIONS; GREASE DISSOLVING CLEANING PREPARATIONS (OTHER THAN FOR USE IN INDUSTRIAL PROCESSES); GREASE REMOVING CLEANING PREPARATIONS FOR USE ON THE SKIN EXCLUDING PREPARATIONS FOR THE HAIR; CLEANING PREPARATIONS FOR THE REMOVAL OF GREASE FOR (HOUSEHOLD USE); DETERGENT RINSE AID PRODUCTS FOR USE IN DISHWASHING MACHINES; DETERGENTS FOR DISHWASHING; DISHWASHER POWDER; DISHWASHING AGENTS FOR DISHWASHING MACHINES; DISHWASHING DETERGENTS; DISHWASHING LIQUID; DISHWASHING PREPARATIONS; DISHWASHING PRODUCTS, NAMELY, CLEANING PREPARATIONS IN THE NATURE OF RINSE ADDITIVES FOR DISHWASHING MACHINES; ALL-PURPOSE LIQUID CLEANERS; POT CLEANING ALL-PURPOSE LIQUIDS CLEANER; SOAPS FOR HOUSEHOLD USE EXCLUDING PREPARATIONS FOR THE HAIR; NON-MEDICATED HAND CLEANERS; HARD SURFACE CLEANING PREPARATIONS; FLOOR CLEANING PREPARATIONS; PREPARATIONS FOR THE CLEANING OF FLOOR COVERINGS; DISINFECTANT SOAP; DISINFECTANT SOAP SOLUTIONS; HOUSEHOLD DETERGENT SHAVING DISINFECTANT PROPERTIES; RUST REMOVING PREPARATIONS; PREPARATIONS FOR REMOVING LIMESCALE FOR (HOUSEHOLD PURPOSES); PREPARATIONS FOR THE REMOVAL OF LIME FOR (HOUSEHOLD USE); DRAIN CLEANING PREPARATIONS; OVEN CLEANING PREPARATIONS; LAUNDRY DETERGENT; LAUNDRY WASHING PREPARATIONS; SOAPS FOR LAUNDRY USE; CLEANING PREPARATIONS FOR LAUNDRY USE; DETERGENTS FOR LAUNDRY USE; FABRIC SOFTENERS (FOR LAUNDRY USE); STAIN REMOVERS; STAIN REMOVING PREPARATIONS; TOILET CLEANERS; STAINLESS STEEL CLEANERS; CHROME POLISH; WOOD CONDITIONER, BRIGHTENER AND RENEWER; UPHOLSTERY CLEANERS; BODY CLEANING PREPARATIONS FOR USE ON THE BODY EXCLUDING PREPARATIONS FOR THE HAIR, COSMETIC PREPARATIONS FOR USE ON THE BODY EXCLUDING PREPARATIONS FOR THE HAIR; SOAPS, SHOWER GELS EXCLUDING PREPARATIONS FOR THE HAIR; SOAPS IN GEL FORMS EXCLUDING PREPARATIONS FOR THE HAIR; ANTIPERSPIRANT DEODORANTS; BODY DEODORANTS; DEODORANT CREAMS FOR PERSONAL USE; DEODORANT PREPARATIONS FOR PERSONAL USE; DEODORANT SOAP; DEODORANT SPRAYS FOR PERSONAL USE; DEODORANT STICKS FOR PERSONAL USE; DEODORANTS FOR PERSONAL USE; DEODORANTS FOR THE BODY; DEODORANTS FOR THE FEET; DOUCHING PREPARATIONS FOR PERSONAL SANITARY OR DEODORANT PURPOSES EXCLUDING PREPARATIONS FOR THE HAIR; ESSENTIAL OILS FOR USE IN DEODORANTS; PERFUMED DEODORANTS FOR USE ON THE PERSON; PERSONAL DEODORANTS; ROLL-ON TOILETRY DEODORANTS; SCENTED DEODORANT

CLASS 3—(Continued).

PREPARATIONS FOR PERSONAL USE; CLEANSERS FOR THE FACE; COSMETIC ACNE CLEANSERS NOT FOR MEDICAL PURPOSES; FACIAL CLEANSERS; HAND CLEANSERS; FACIAL SOAPS; COSMETIC FACIAL TONERS; COSMETIC FACIAL WASHES; FACIAL WIPES IMPREGNATED WITH COSMETICS; NON-MEDICATED CREAMS FOR FACIAL SCRUBS; SUNSCREEN PREPARATIONS; LIQUID SOAPS; LIQUID HAND SOAPS; SOAPS FOR PERSONAL USE; BAR SOAP; DISPOSABLE WIPES INCORPORATING CLEANING PREPARATIONS FOR PERSONAL HYGIENE DISPOSABLE WIPES INCORPORATING CLEANING PREPARATIONS FOR HOUSEHOLD USE (U.S. CLS. 1, 4, 6, 50, 51 AND 52).
MORGAN WYNNE, EXAMINING ATTORNEY

CLASS 3—(Continued).

SN 85-137,970. TAYLOR, JOSHUA I, SAN FRANCISCO, CA. FILED 9-24-2010.

NECTAR

SN 85-135,442. JNC COSMETIC CO., LTD, SEOUL, REPUBLIC OF KOREA, FILED 9-22-2010.



NO CLAIM IS MADE TO THE EXCLUSIVE RIGHT TO USE "NATURAL COSMETIC", APART FROM THE MARK AS SHOWN.

THE MARK CONSISTS OF THE LETTERS "J N C" - EACH LETTER SEPARATED BY A BACK SLASH AND UNDERLINED WITH A BOLD LINE AND THE WORDS "NATURAL COSMETIC" UNDERNEATH THE BOLD LINE.

FOR COSMETICS; EYE CREAM; MASK PACK FOR COSMETIC PURPOSES; MAKE-UP POWDER; COSMETIC PREPARATIONS FOR THE HAIR AND SCALP; BATH SOAP; COSMETIC CREAMS; ESSENTIAL OILS; ETHEREAL OILS; SKIN LOTIONS (U.S. CLS. 1, 4, 6, 50, 51 AND 52).

SKYE YOUNG, EXAMINING ATTORNEY

THE MARK CONSISTS OF STANDARD CHARACTERS WITHOUT CLAIM TO ANY PARTICULAR FONT, STYLE, SIZE, OR COLOR.

FOR BODY LOTION, HAND CREAM, FACE CREAM, FACE SCRUB, BATH GEL, SHOWER GEL, BUBBLE BATH, FACE SOAP, BODY SOAP, LIQUID BODY WASH, LIQUID SOAP, BODY BUTTER, BATH SALT, SHAMPOO, HAIR CONDITIONER, COSMETICS, PERFUME, TOILET WATER, MASSAGE OIL, MASSAGE CREAM, NON-MEDICATED FOOT CREAMS (U.S. CLS. 1, 4, 6, 50, 51 AND 52).

DOUGLAS LEE, EXAMINING ATTORNEY

SN 85-143,408. BEYOND ORGANICS VENTURE GROUP, INC., NEWPORT BEACH, CA. FILED 10-1-2010.

CHIROCEUTICALS

SN 85-136,345. SALTWORKS, INC., WOODINVILLE, WA. FILED 9-23-2010.

RELIEF RX

THE MARK CONSISTS OF STANDARD CHARACTERS WITHOUT CLAIM TO ANY PARTICULAR FONT, STYLE, SIZE, OR COLOR.

NO CLAIM IS MADE TO THE EXCLUSIVE RIGHT TO USE "RX", APART FROM THE MARK AS SHOWN.

FOR NON-MEDICATED BATH SALTS (U.S. CLS. 1, 4, 6, 50, 51 AND 52).

FIRST USE 2-0-2003; IN COMMERCE 2-0-2003.

NAPOLEON SHARMA, EXAMINING ATTORNEY

THE MARK CONSISTS OF STANDARD CHARACTERS WITHOUT CLAIM TO ANY PARTICULAR FONT, STYLE, SIZE, OR COLOR.

FOR COSMETICS PREPARATIONS AND PERSONAL CARE PRODUCTS, NAMELY, AGE RETARDANT LOTIONS; ANTI-AGING CREAMS; ANTI WRINKLE CREAMS; BLUSH; BLUSHER; BODY CREAMS; BODY LOTIONS; BODY OILS; COLD CREAMS; COSMETIC PREPARATIONS FOR SKIN RENEWAL; COSMETICS; EYE CREAMS; EYE GELS; FACE CREAMS; FACIAL CONCEALERS; FOUNDATION MAKEUP; HAND CREAMS; HAND LOTIONS; MAKEUP; NIGHT CREAMS; SKIN CLARIFIERS; SKIN CLEANSERS; SKIN CLEANSING CREAMS; SKIN CLEANSING LOTIONS; SKIN CONDITIONERS; SKIN CREAMS; SKIN LOTIONS; SKIN MOISTURIZERS; SKIN TONERS; SUN CARE LOTIONS; SUN CREAMS; SHAMPOOS; HAIR CONDITIONERS (U.S. CLS. 1, 4, 6, 50, 51 AND 52).

ANDREA K. NADELMAN, EXAMINING ATTORNEY

CLASS 3—(Continued).

SN 85-150,755. SCHLAEGER, BRADLEY D, GOLDEN VALLEY, MN. FILED 10-12-2010.

Clean Enhanced Organics

THE MARK CONSISTS OF STANDARD CHARACTERS WITHOUT CLAIM TO ANY PARTICULAR FONT, STYLE, SIZE, OR COLOR.

NO CLAIM IS MADE TO THE EXCLUSIVE RIGHT TO USE "ORGANICS", APART FROM THE MARK AS SHOWN.

FOR CONDITIONERS; HAIR CONDITIONERS; HAIR GELS; HAIR LACQUERS; HAIR SHAMPOO; HAIR SHAMPOOS AND CONDITIONERS; HAIR SPRAYS; HAIR SPRAYS AND HAIR GELS; HAIR STYLING SPRAY; HAIR TONICS; ALL GOODS CONTAIN ORGANIC MATERIALS (U.S. CLS. 1, 4, 6, 50, 51 AND 52).

FIRST USE 10-11-2010; IN COMMERCE 10-11-2010.
TIMOTHY FINNEGAN, EXAMINING ATTORNEY

CLASS 3—(Continued).

SN 85-172,066. DAVENPORT, FELISHIA, BATON ROUGE, LA. FILED 11-8-2010.

BELLA SWAB

THE MARK CONSISTS OF STANDARD CHARACTERS WITHOUT CLAIM TO ANY PARTICULAR FONT, STYLE, SIZE, OR COLOR.

NO CLAIM IS MADE TO THE EXCLUSIVE RIGHT TO USE "SWAB", APART FROM THE MARK AS SHOWN.

FOR DISPOSABLE WIPES IMPREGNATED WITH CLEANSING CHEMICALS OR COMPOUNDS FOR PERSONAL HYGIENE; FEMININE HYGIENE CLEANSING TOWELETTES (U.S. CLS. 1, 4, 6, 50, 51 AND 52).

WILLIAM BRECKENFELD, EXAMINING ATTORNEY

SN 85-178,669. ORKIN EXPANSION, INC., WILMINGTON, DE. FILED 11-17-2010.

ORKIN ACTIZYME

THE MARK CONSISTS OF STANDARD CHARACTERS WITHOUT CLAIM TO ANY PARTICULAR FONT, STYLE, SIZE, OR COLOR.

OWNER OF U.S. REG. NOS. 568,404, 568,407 AND OTHERS.

FOR CLEANING PREPARATIONS (U.S. CLS. 1, 4, 6, 50, 51 AND 52).

FRANK LATTUCA, EXAMINING ATTORNEY

SN 85-157,802. MALIDERMA NATURAL SOLUTIONS INC., ORANGEVILLE, ONTARIO, CANADA, FILED 10-21-2010.

FIRMASHAPE

THE MARK CONSISTS OF STANDARD CHARACTERS WITHOUT CLAIM TO ANY PARTICULAR FONT, STYLE, SIZE, OR COLOR.

FOR SKIN CARE PREPARATIONS, NAMELY, SKIN AND BODY LOTIONS, CREAMS, GELS, TONICS, SPRAYS; SHOWER GELS, FOAM BATHS, BATH OILS AND PRE-MOISTENED COSMETIC TOWELETTES; COSMETIC PREPARATIONS FOR MOISTURIZING, FIRING, REDUCING THE APPEARANCE OF CELLULITE, SMOOTHING AND CONDITIONING THE SKIN, NAMELY, FIRING LOTIONS, FIRING CREAMS, BODY FIRING GELS, FIRING TONICS, FIRING SPRAYS, BODY CONTOUR CREAMS, SKIN TONING CREAMS, LOTIONS AND CREAMS FOR CELLULITE REDUCTION; NON-MEDICATED LOTIONS FOR CONDITIONING OF THE SKIN, NON-MEDICATED CREAMS FOR CONDITIONING OF THE SKIN, NON-MEDICATED GELS FOR CONDITIONING OF THE SKIN, NON-MEDICATED TONICS FOR CONDITIONING OF THE SKIN, NON-MEDICATED SPRAYS FOR CONDITIONING OF THE SKIN (U.S. CLS. 1, 4, 6, 50, 51 AND 52).

FIRST USE 10-15-2010; IN COMMERCE 10-15-2010.
ALICE BENMAMAN, EXAMINING ATTORNEY

SN 85-181,430. SOLIS, GILDA AUSTIN, MEXICO DF CP:14210, MEXICO, FILED 11-19-2010.



THE MARK CONSISTS OF A HUMMINGBIRD WITH ITS CLAWS GRASPING TWO CONCENTRIC OVALS.

FOR FACIAL CREAM (U.S. CLS. 1, 4, 6, 50, 51 AND 52).
TRACY WHITTAKER-BROWN, EXAMINING ATTORNEY

CLASS 3—(Continued).

SN 85-187,533. L'AMOURAGE, LUTHERVILLE, MD. FILED 11-30-2010.

L'amourage

THE MARK CONSISTS OF STANDARD CHARACTERS WITHOUT CLAIM TO ANY PARTICULAR FONT, STYLE, SIZE, OR COLOR.

FOR ANTI-AGING CLEANSER; ANTI-AGING MOISTURIZER; ANTI-AGING TONER; AROMATIC BODY CARE PRODUCTS, NAMELY, BODY LOTION, SHOWER GEL, CUTICLE CREAM, SHAMPOO, CONDITIONER, NON-MEDICATED LIP BALM, SOAP, BODY POLISH, BODY AND FOOT SCRUB AND NON-MEDICATED FOOT CREAM; BATH AND SHOWER GELS AND SALTS NOT FOR MEDICAL PURPOSES; BATH FOAM; BATH GEL; BATH LOTION; BATH OILS AND BATH SALTS; BATH SOAPS; BATHING LOTIONS; BEAUTY CREAMS FOR BODY CARE; BEAUTY LOTIONS; BEAUTY MASKS; BEAUTY SERUMS; BODY CREAM; BODY LOTION; BODY LOTIONS; BODY MASK CREAM; BODY MASK LOTION; BODY MASKS; BODY OIL; BODY OILS; BODY SCRUB; BODY SPRAY USED AS A PERSONAL DEODORANT AND AS FRAGRANCE; BODY SPRAYS; BODY WASH; CLEANING AND WASHING PREPARATIONS; COLOGNES, PERFUMES AND COSMETICS; COSMETIC PREPARATIONS FOR EYE LASHES; EYE COMPRESSES FOR COSMETIC PURPOSES; EYE CREAM; EYE GELS; EYE LOTIONS; EYE MAKE-UP; EYE MAKE-UP REMOVER; EYES MAKE-UP; FACE AND BODY BEAUTY CREAMS; FACE AND BODY CREAMS; FACE AND BODY LOTIONS; FACE CREAMS; FACE CREAMS AND CLEANSERS CONTAINING BENZOYL PEROXIDE FOR COSMETIC PURPOSES; FACE-POWDER ON PAPER; FACIAL BEAUTY MASKS; FACIAL CLEANSERS; FACIAL MASKS; FACIAL MOISTURIZER WITH SPF; FACIAL SCRUBS; FACIAL WASHES; FRAGRANCED FACIAL MOISTURIZER; GEL EYE MASKS; HAIR RINSES; HAIR SHAMPOO; HAIR SHAMPOOS AND CONDITIONERS; LIQUID SOAPS FOR HANDS AND FACE; LIQUID SOAPS FOR HANDS, FACE AND BODY; LOTIONS FOR FACE AND BODY CARE; MAKE UP REMOVING PREPARATIONS; MAKE-UP REMOVER; MASSAGE LOTIONS; MOISTURIZING CREAMS; MOISTURIZING SOLUTIONS FOR THE SKIN; NON-MEDICATED FACIAL AND EYE SERUM CONTAINING ANTIOXIDANTS; SCENTED BODY LOTIONS AND CREAMS; SCENTED BODY SPRAY; SCENTED ROOM SPRAYS; SHOWER AND BATH GEL; SKIN CLEANSING LOTION; SKIN LOTION; SKIN MASKS; SKIN MOISTURIZER; SKIN MOISTURIZER MASKS; SKIN MOISTURIZING GEL; SKIN TONERS; TONING LOTION, FOR THE FACE, BODY AND HANDS (U.S. CLS. 1, 4, 6, 50, 51 AND 52).

FIRST USE 7-1-2010; IN COMMERCE 7-1-2010.
PAUL MORENO, EXAMINING ATTORNEY

CLASS 3—(Continued).

SN 85-196,370. COTTON BABIES, INC., ST. LOUIS, MO. FILED 12-13-2010.

COTTON BABIES

THE MARK CONSISTS OF STANDARD CHARACTERS WITHOUT CLAIM TO ANY PARTICULAR FONT, STYLE, SIZE, OR COLOR.

OWNER OF U.S. REG. NOS. 3,158,222 AND 3,846,526.
NO CLAIM IS MADE TO THE EXCLUSIVE RIGHT TO USE "BABIES", APART FROM THE MARK AS SHOWN.
FOR DETERGENTS AND ODOR REMOVERS FOR DIAPER PRODUCTS, BABY WIPES, AND BABY CLEANSERS (U.S. CLS. 1, 4, 6, 50, 51 AND 52).
CAROLYN CATALDO, EXAMINING ATTORNEY

SN 85-205,880. ELLIS-HERVEY, NINA, FLORISSANT, MO. FILED 12-27-2010.



THE MARK CONSISTS OF THE STYLIZED TEXT "BEAUTIFUL BRWNBABYDOL" UNDER A CARTOON OF A WOMAN FROM THE SHOULDERS AND UP WITH CURLY HAIR.

FOR HAIR CARE PREPARATIONS (U.S. CLS. 1, 4, 6, 50, 51 AND 52).
FIRST USE 9-25-2010; IN COMMERCE 9-25-2010.
JEFFERY COWARD, EXAMINING ATTORNEY

SN 85-213,704. LIBERTY BELL INVESTMENTS LLC., CHAMPAIGN, IL. FILED 1-10-2011.

SOHI

THE MARK CONSISTS OF STANDARD CHARACTERS WITHOUT CLAIM TO ANY PARTICULAR FONT, STYLE, SIZE, OR COLOR.

THE WORD(S) "SOHI" HAS NO MEANING IN A FOREIGN LANGUAGE.

FOR INCENSE (U.S. CLS. 1, 4, 6, 50, 51 AND 52).
FIRST USE 9-1-2010; IN COMMERCE 10-1-2010.
DEZMONA MIZELLE, EXAMINING ATTORNEY

CLASS 3—(Continued).

SN 85-216,285. KOKUBO & CO., LTD., WAKAYAMA, JAPAN,
FILED 1-12-2011.



THE MARK CONSISTS OF A RECTANGLE, TRAPEZOID AND OVAL TO MAKE A STYLIZED DESIGN OF THE LETTER "K".

FOR BATH ADDITIVES, NAMELY, BATH BEADS, BATH CRYSTALS, BATH FIZZIES, BATH FLAKES, BATH FOAMS, BATH MILKS, BATH OILS, BATH PEARLS, BATH POWDER AND BATH SALTS; BODY SCRUB; BODY WASH; CLEANING AGENTS AND PREPARATIONS FOR CLEANSING DRAINS AND HOUSEHOLD PURPOSES; CLEANING SWABS FOR HOUSEHOLD PURPOSES; CLOTHS IMPREGNATED WITH A DETERGENT FOR CLEANING; CLOTHS IMPREGNATED WITH A SKIN CLEANSER; COTTON SWABS; DENTURE CLEANERS; DRAIN OPENERS; FACIAL CLEANSERS; DRAIN OPENERS FOR DISSOLVING HAIR; HAIR REMOVAL COSMETIC PADS MADE OF FINE SANDPAPER USED AS AN ABRASIVE FOR HAIR REMOVAL; SKIN EXFOLIATING COSMETIC PADS MADE OF FINE SANDPAPER USED AS AN ABRASIVE FOR SKIN REMOVAL; STAIN REMOVERS (U.S. CLS. 1, 4, 6, 50, 51 AND 52).

WILLIAM ROSSMAN, EXAMINING ATTORNEY

SN 85-232,196. INTERNATIONAL EDGE, INC., FAIRFIELD, NJ. FILED 2-2-2011.

GOLDEN CREST

THE MARK CONSISTS OF STANDARD CHARACTERS WITHOUT CLAIM TO ANY PARTICULAR FONT, STYLE, SIZE, OR COLOR.

FOR NON-MEDICATED SKIN CLEANSER, LIP BALM, EYE CREAM AND NIGHT CREAM (U.S. CLS. 1, 4, 6, 50, 51 AND 52).

NAPOLEON SHARMA, EXAMINING ATTORNEY

CLASS 3—(Continued).

SN 85-237,299. ARDALAN, CARMEN, LAFAYETTE, CO.
FILED 2-8-2011.

everywhere balm

THE MARK CONSISTS OF STANDARD CHARACTERS WITHOUT CLAIM TO ANY PARTICULAR FONT, STYLE, SIZE, OR COLOR.

NO CLAIM IS MADE TO THE EXCLUSIVE RIGHT TO USE "BALM", APART FROM THE MARK AS SHOWN.

FOR NON-MEDICATED HERBAL BODY CARE PRODUCTS, NAMELY, BODY OILS, SALVES, AND LIP BALMS (U.S. CLS. 1, 4, 6, 50, 51 AND 52).

FIRST USE 11-1-2010; IN COMMERCE 1-19-2011.

NAKWAMA ANKRAH, EXAMINING ATTORNEY

SN 85-240,585. POUND, L RYAN, DBA NATURES PARADISE, HUNTINGTON BEACH, CA. FILED 2-11-2011.



NO CLAIM IS MADE TO THE EXCLUSIVE RIGHT TO USE "ORGANICALLY CLEAN", APART FROM THE MARK AS SHOWN.

THE COLOR(S) GREEN, GREY, WHITE, ORANGE, BLUE, RED AND BLACK IS/ARE CLAIMED AS A FEATURE OF THE MARK.

THE MARK CONSISTS OF THE LETTER WORD "ORGANICALLY" IN THE COLOR GREEN, THE "O" BEING UPPERCASE AND THE REST LOWER CASE. BELOW TO THE LEFT OF THE WORD "ORGANICALLY" IS THE WORD IN ALL CAPITALS "CLEAN" IN THE COLOR GREY. ABOVE THE LETTERING "ORGANICALLY" IS A PHOTO OF A TREE FROG, THE TREE FROG IS ON ALL FOUR LEGS WITH ITS HEAD TILTED TO ITS RIGHT SIDE, LOOKING OUT. THE TREE FROG HAS A GREEN HEAD WITH A WHITE NECK AND UNDERBELLY, ITS EYES ARE LARGE RED CIRCLES WITH BLACK PUPILS ON THE SIDES OF ITS HEAD. IT HAS GREEN LEGS WITH BLUE UNDERNEATH THE LEGS AND ORANGE FEET. THERE IS A GREY SHADOW UNDERNEATH THE TREE FROG.

FOR ALL-PURPOSE ORGANIC CLEANERS (U.S. CLS. 1, 4, 6, 50, 51 AND 52).

FIRST USE 1-1-2011; IN COMMERCE 1-1-2011.

RAUL CORDOVA, EXAMINING ATTORNEY

CLASS 3—(Continued).

SN 85-245,339. EMINENCE ORGANIC SKINCARE INC., VANCOUVER, B.C., CANADA, FILED 2-17-2011.

STRAWBERRY RHUBARB DERMAFOLIANT

THE MARK CONSISTS OF STANDARD CHARACTERS WITHOUT CLAIM TO ANY PARTICULAR FONT, STYLE, SIZE, OR COLOR.

NO CLAIM IS MADE TO THE EXCLUSIVE RIGHT TO USE "STRAWBERRY RHUBARB", APART FROM THE MARK AS SHOWN.

FOR EXFOLIANTS FOR FACIAL AND BODY MASKS; SKIN CLEANSERS (U.S. CLS. 1, 4, 6, 50, 51 AND 52).

TARA PATE, EXAMINING ATTORNEY

SN 85-248,518. LIMITED STORES, LLC, NEW ALBANY, OH. FILED 2-22-2011.

EDITION NO. 1 CARDIGAN

THE MARK CONSISTS OF STANDARD CHARACTERS WITHOUT CLAIM TO ANY PARTICULAR FONT, STYLE, SIZE, OR COLOR.

FOR PERSONAL CARE PRODUCTS, NAMELY, FRAGRANCES (U.S. CLS. 1, 4, 6, 50, 51 AND 52).

KATHRYN COWARD, EXAMINING ATTORNEY

SN 85-258,744. VILLANUEVA, JOHN, DBA ZEN CASTLE, ALEXANDRIA, VA. FILED 3-4-2011.

ZENCASTLE

THE MARK CONSISTS OF STANDARD CHARACTERS WITHOUT CLAIM TO ANY PARTICULAR FONT, STYLE, SIZE, OR COLOR.

OWNER OF U.S. REG. NOS. 3,599,476 AND 3,750,226.

THE WORDING "ZENCASTLE" HAS NO MEANING IN A FOREIGN LANGUAGE.

FOR AFTER SHAVE LOTIONS; ANTIPERSPIRANTS AND DEODORANTS FOR PERSONAL USE; AROMATIC BODY CARE PRODUCTS, NAMELY, BODY LOTION, SHOWER GEL, CUTICLE CREAM, SHAMPOO, CONDITIONER, NON-MEDICATED LIP BALM, SOAP, BODY POLISH, BODY AND FOOT SCRUB AND NON-MEDICATED FOOT CREAM; BABY LOTION; BAR SOAP; BATH AND SHOWER GELS AND SALTS NOT FOR MEDICAL PURPOSES; BATH CRYSTALS; BATH FIZZIES; BATH LOTION; BATH OILS AND BATH SALTS; BATH SALTS; BATH SOAPS; BATH SOAPS IN LIQUID, SOLID OR GEL FORM; BATHING LOTIONS; BEAUTY CREAMS FOR BODY CARE; BEAUTY LOTIONS; BEAUTY SOAP; BODY LOTION; COSMETIC CREAMS FOR SKIN CARE; DEODORANT FOR PERSONAL USE; DEODORANTS AND ANTIPERSPIRANTS; DEODOR-

CLASS 3—(Continued).

ANTS AND ANTIPERSPIRANTS FOR PERSONAL USE; EYE LOTIONS; FACE AND BODY LOTIONS; FACIAL LOTION; HAIR CARE LOTIONS; HAIR SHAMPOOS AND CONDITIONERS; HAND LOTIONS; LIP BALM; LOTIONS FOR FACE AND BODY CARE; MINERAL SALT IN THE NATURE OF BATH SALTS NOT FOR MEDICAL PURPOSES; NATURAL COCOA BUTTER BASED PERSONAL CARE PRODUCTS, NAMELY, BODY LOTION, SHOWER GEL, SOAP, BODY POLISH, BODY AND FOOT SCRUB AND NON-MEDICATED SKIN CREAMS; NON-MEDICATED DIAPER RASH OINTMENTS AND LOTIONS; NON-MEDICATED FOOT LOTIONS; NON-MEDICATED HERBAL BODY CARE PRODUCTS, NAMELY, BODY OILS, SALVES, AND LIP BALMS; NON-MEDICATED SKIN CARE PREPARATIONS, NAMELY, CREAMS, LOTIONS, GELS, TONERS, CLEANERS AND PEELS; SCENTED BODY LOTIONS AND CREAMS; SHAVING BALM; SHAVING LOTIONS; SKIN LOTIONS; SUN CARE LOTIONS; TONING LOTION, FOR THE FACE, BODY AND HANDS (U.S. CLS. 1, 4, 6, 50, 51 AND 52).

FIRST USE 1-1-2007. THE MARK WAS FIRST USED ANYWHERE IN A DIFFERENT FORM OTHER THAN THAT SOUGHT TO BE REGISTERED AT LEAST AS EARLY AS 01/01/2007. ; IN COMMERCE 1-1-2007, THE MARK WAS FIRST USED IN COMMERCE IN A DIFFERENT FORM OTHER THAN THAT SOUGHT TO BE REGISTERED AT LEAST AS EARLY AS 01/01/2007..

KELLEY WELLS, EXAMINING ATTORNEY

SN 85-259,594. AVOCADO DREAMIN LLC, FALLBROOK, CA. FILED 3-7-2011.

Horseman's Therapy Hands Down

THE MARK CONSISTS OF STANDARD CHARACTERS WITHOUT CLAIM TO ANY PARTICULAR FONT, STYLE, SIZE, OR COLOR.

NO CLAIM IS MADE TO THE EXCLUSIVE RIGHT TO USE "THERAPY", APART FROM THE MARK AS SHOWN.

FOR BEAUTY LOTIONS; BODY LOTION; BODY LOTIONS; FACE AND BODY LOTIONS; FACIAL LOTION; HAND LOTIONS; LOTIONS FOR FACE AND BODY CARE; LOTIONS FOR SKIN, FACE, BODY; NON-MEDICATED SKIN CARE CREAMS AND LOTIONS; NON-MEDICATED SKIN CARE PREPARATIONS, NAMELY, CREAMS, LOTIONS, GELS, TONERS, CLEANERS AND PEELS; SCENTED BODY LOTIONS AND CREAMS; SKIN AND BODY TOPICAL LOTIONS, CREAMS AND OILS FOR COSMETIC USE; SKIN LOTION; SKIN LOTIONS (U.S. CLS. 1, 4, 6, 50, 51 AND 52).

FIRST USE 9-30-2010; IN COMMERCE 10-1-2010.

WENDY JUN, EXAMINING ATTORNEY

CLASS 3—(Continued).

SN 85-262,958. ERES, PARIS, FRANCE, FILED 3-10-2011.



OWNER OF U.S. REG. NOS. 2,320,998, 3,385,892 AND OTHERS.

THE MARK CONSISTS OF THE STYLIZED LETTERS "E", "R", "E" AND "S".

THE ENGLISH TRANSLATION OF "ERES" IN THE MARK IS "YOU ARE".

FOR ESSENTIAL OILS; NAIL CARE PREPARATIONS; PERFUMERY (U.S. CLS. 1, 4, 6, 50, 51 AND 52).

WENDY GOODMAN, EXAMINING ATTORNEY

SN 85-265,736. SERVICEMASTER BRANDS L.L.C., BURLINGTON, VT. FILED 3-14-2011.

FURNITURE MEDIC

THE MARK CONSISTS OF STANDARD CHARACTERS WITHOUT CLAIM TO ANY PARTICULAR FONT, STYLE, SIZE, OR COLOR.

OWNER OF U.S. REG. NOS. 1,712,243, 3,599,116 AND OTHERS.

NO CLAIM IS MADE TO THE EXCLUSIVE RIGHT TO USE "FURNITURE", APART FROM THE MARK AS SHOWN.

FOR STRIPPING PREPARATIONS FOR REFINISHING AND RENOVATING FURNITURE AND WOOD PRODUCTS AND FIXTURES; CLEANING AND POLISHING PREPARATIONS FOR FURNITURE AND WOOD PRODUCTS AND FIXTURES (U.S. CLS. 1, 4, 6, 50, 51 AND 52).

FIRST USE 9-22-1991; IN COMMERCE 9-22-1991.

NAAKWAMA ANKRAH, EXAMINING ATTORNEY

SN 85-265,967. KO MANUFACTURING, INC., SPRINGFIELD, MO. FILED 3-14-2011.

KLEEN RELIEF

THE MARK CONSISTS OF STANDARD CHARACTERS WITHOUT CLAIM TO ANY PARTICULAR FONT, STYLE, SIZE, OR COLOR.

NO CLAIM IS MADE TO THE EXCLUSIVE RIGHT TO USE "CLEAN", APART FROM THE MARK AS SHOWN.

FOR ALL-PURPOSE CLEANERS; BODY WASH; CLEANING AND WASHING PREPARATIONS; LAUNDRY DETERGENT (U.S. CLS. 1, 4, 6, 50, 51 AND 52).

ANGELA M. MICHELI, EXAMINING ATTORNEY

CLASS 3—(Continued).

SN 85-266,927. MURAD, INC., EL SEGUNDO, CA. FILED 3-15-2011.

ABSOLUTE BRONZING BOOST

THE MARK CONSISTS OF STANDARD CHARACTERS WITHOUT CLAIM TO ANY PARTICULAR FONT, STYLE, SIZE, OR COLOR.

NO CLAIM IS MADE TO THE EXCLUSIVE RIGHT TO USE "BRONZING", APART FROM THE MARK AS SHOWN. FOR COSMETICS; NON-MEDICATED SKIN CARE PREPARATIONS, NAMELY, CREAMS, LOTIONS, GELS, TONERS, CLEANERS AND PEELS (U.S. CLS. 1, 4, 6, 50, 51 AND 52).

KEVON CHISOLM, EXAMINING ATTORNEY

SN 85-267,691. ALEATHA JOSEPH, DBA SERENE ESSENTIALS, UNION, NJ. FILED 3-15-2011.

Serene Essentials

THE MARK CONSISTS OF STANDARD CHARACTERS WITHOUT CLAIM TO ANY PARTICULAR FONT, STYLE, SIZE, OR COLOR.

OWNER OF U.S. REG. NOS. 3,792,025 AND 3,969,276.

FOR BATH OILS; BATH OILS AND BATH SALTS; BATH OILS FOR COSMETIC PURPOSES; BERGAMOT OIL; BODY OIL; BODY OILS; COSMETIC OILS; COSMETIC OILS FOR THE EPIDERMIS; COSMETIC OLIVE OIL FOR THE FACE AND BODY; COSMETIC SUN OILS; ESSENTIAL OILS; ESSENTIAL OILS AS PERFUME FOR LAUNDRY PURPOSES; ESSENTIAL OILS FOR AROMA THERAPY USE; ESSENTIAL OILS FOR HOUSEHOLD USE; ESSENTIAL OILS FOR PERSONAL USE; ESSENTIAL OILS FOR USE IN AROMA THERAPY; ESSENTIAL OILS FOR USE IN MANUFACTURING OF HANDMADE SOAPS; ESSENTIAL OILS FOR USE IN THE MANUFACTURE OF SCENTED PRODUCTS; GRAPE SEED OIL FOR COSMETIC USE; JASMINE OIL FOR PERSONAL USE; LAVENDER OIL; MASSAGE OIL; MASSAGE OILS; NATURAL ESSENTIAL OILS; NON-MEDICATED COSMETIC SKIN CARE PREPARATIONS CONSISTING OF ORGANIC COCONUT VIRGIN OIL AND COCONUT VIRGIN OIL; NON-MEDICATED HERBAL BODY CARE PRODUCTS, NAMELY, BODY OILS, SALVES, AND LIP BALMS; NON-MEDICATED SKIN CREAMS WITH ESSENTIAL OILS FOR USE IN AROMA THERAPY; OIL BATHS FOR HAIR CARE; OILS FOR CLEANING PURPOSES; OILS FOR COSMETIC PURPOSES; OILS FOR HAIR CONDITIONING; OILS FOR PERFUMES AND SCENTS; OILS FOR TOILETRY PURPOSES; PEPPERMINT OIL; PERFUME OILS; PERFUME OILS FOR THE MANUFACTURE OF COSMETIC PREPARATIONS; REEDS AND SCENTED OILS SOLD AS A UNIT FOR USE IN ROOM SCENT DIFFUSERS; ROSE OIL FOR COSMETIC PURPOSES; SCENTED OILS; SCENTED OILS USED TO PRODUCE AROMAS WHEN HEATED; SKIN AND BODY TOPICAL LOTIONS, CREAMS AND OILS FOR COSMETIC USE (U.S. CLS. 1, 4, 6, 50, 51 AND 52).

FIRST USE 3-1-2006; IN COMMERCE 3-1-2006.

HAI-LY LAM, EXAMINING ATTORNEY

CLASS 3—(Continued).

SN 85-268,286. COLOMER ITALY, S.P.A., BOLOGNA, ITALY,
FILED 3-16-2011.

INTERCOSMO NUTRILUX

THE MARK CONSISTS OF STANDARD CHARACTERS WITHOUT CLAIM TO ANY PARTICULAR FONT, STYLE, SIZE, OR COLOR.

FOR HAIR CARE LOTIONS; HAIR CARE PREPARATIONS; HAIR CLEANING PREPARATIONS; HAIR CONDITIONER; SHAMPOO; HAIR MASKS; HAIR CREAMS; HAIR COLORING PREPARATIONS; HAIR DYES; HAIR GELS; HAIR WAXES; HAIR MOUSSE; HAIR SPRAYS; HAIR OILS; HAIR NOURISHERS; HAIR POMADES; HAIR STYLING PREPARATIONS; PREPARATIONS FOR PERMANENT HAIR WAVES; HAIR WAVING PREPARATIONS; HAIR EMOLLIENTS; HAIR COLOURANTS; HAIR FROSTS; HAIR GLAZE; HAIR LACQUERS; HAIR LIGHTENERS; AND NONMEDICATED HAIR SERUM (U.S. CLS. 1, 4, 6, 50, 51 AND 52).
MICHAEL ENGEL, EXAMINING ATTORNEY

SN 85-268,291. COLOMER ITALY, S.P.A., BOLOGNA, ITALY,
FILED 3-16-2011.

INTERCOSMO IL MAGNIFICO

THE MARK CONSISTS OF STANDARD CHARACTERS WITHOUT CLAIM TO ANY PARTICULAR FONT, STYLE, SIZE, OR COLOR.

THE ENGLISH TRANSLATION OF "IL MAGNIFICO" IN THE MARK IS "THE MAGNIFICENT".

FOR HAIR CARE LOTIONS; HAIR CARE PREPARATIONS; HAIR CLEANING PREPARATIONS; HAIR CONDITIONER; SHAMPOO; HAIR MASKS; HAIR CREAMS; HAIR COLORING PREPARATIONS; HAIR DYES; HAIR GELS; HAIR WAXES; HAIR MOUSSE; HAIR SPRAYS; HAIR OILS; HAIR NOURISHERS; HAIR POMADES; HAIR STYLING PREPARATIONS; PREPARATIONS FOR PERMANENT HAIR WAVES; HAIR WAVING PREPARATIONS; HAIR EMOLLIENTS; AND NONMEDICATED HAIR SERUM (U.S. CLS. 1, 4, 6, 50, 51 AND 52).
MICHAEL ENGEL, EXAMINING ATTORNEY

CLASS 3—(Continued).

SN 85-268,322. COLOMER ITALY, S.P.A., BOLOGNA, ITALY,
FILED 3-16-2011.

INTERCOSMO ENERGIA

THE MARK CONSISTS OF STANDARD CHARACTERS WITHOUT CLAIM TO ANY PARTICULAR FONT, STYLE, SIZE, OR COLOR.

THE ENGLISH TRANSLATION OF "ENERGIA" IN THE MARK IS "ENERGY".

FOR COSMETICS; COSMETIC CREAMS; HAND CREAM; SKIN CREAM; SKIN CARE PREPARATIONS, NAMELY, SKIN PEELS; BODY CREAM; HAIR CARE LOTIONS; HAIR CARE PREPARATIONS; HAIR CLEANING PREPARATIONS; HAIR CONDITIONER; SHAMPOO; HAIR MASKS; HAIR CREAMS; HAIR COLORING PREPARATIONS; HAIR DYES; HAIR GELS; HAIR WAXES; HAIR MOUSSE; HAIR SPRAYS; HAIR OILS; HAIR NOURISHERS; HAIR POMADES; HAIR STYLING PREPARATIONS; PREPARATIONS FOR PERMANENT HAIR WAVES; HAIR WAVING PREPARATIONS; HAIR EMOLLIENTS; AND NONMEDICATED HAIR SERUM (U.S. CLS. 1, 4, 6, 50, 51 AND 52).
MICHAEL ENGEL, EXAMINING ATTORNEY

SN 85-269,022. NEPTUNE NATURAL LLC, CLARE, MI.
FILED 3-16-2011.



NO CLAIM IS MADE TO THE EXCLUSIVE RIGHT TO USE "NATURAL", APART FROM THE MARK AS SHOWN.

THE MARK CONSISTS OF A CIRCLE WITH THE WORDS "NEPTUNE NATURAL" INSIDE AND 3 DROPS OF WATER ON THE CIRCUMFERENCE OF THE CIRCLE.

FOR PERSONAL HAIR CARE PREPARATIONS FOR HEAD AND SCALP (U.S. CLS. 1, 4, 6, 50, 51 AND 52).

FIRST USE 2-2-2011; IN COMMERCE 2-2-2011.

FLORENTINA BLANDU, EXAMINING ATTORNEY

CLASS 3—(Continued).

SN 85-270,155. EARTHWHILE ENTERPRISES, INC., SAN FRANCISCO, CA. FILED 3-17-2011.

SHEAPET

THE MARK CONSISTS OF STANDARD CHARACTERS WITHOUT CLAIM TO ANY PARTICULAR FONT, STYLE, SIZE, OR COLOR.

FOR NON-MEDICATED GROOMING PREPARATIONS FOR USE ON PETS, NAMELY, SHAMPOOS, CONDITIONERS, SKIN CONDITIONING AND DANDER CARE SPRAYS, MOISTURIZING SPRAYS, DETANGLING SPRAYS AND SKIN CONDITIONING BALM; NON-MEDICATED GROOMING PREPARATIONS FOR USE ON PETS, NAMELY, GROOMING WIPES, EAR CLEANSING WIPES, EYE CLEANSING WIPES AND LIQUID EAR CLEANER; AND NON-MEDICATED DENTAL RINSE; ALL THE AFOREMENTIONED CONTAINING SHEA BUTTER (U.S. CLS. 1, 4, 6, 50, 51 AND 52).

FIRST USE 9-17-2002; IN COMMERCE 10-7-2002.
LINDA POWELL, EXAMINING ATTORNEY

SN 85-270,890. JEAN ALEXANDER COSMETICS, INC., MCKEES ROCKS, PA. FILED 3-18-2011.

COLOR SPLASH

THE MARK CONSISTS OF STANDARD CHARACTERS WITHOUT CLAIM TO ANY PARTICULAR FONT, STYLE, SIZE, OR COLOR.

NO CLAIM IS MADE TO THE EXCLUSIVE RIGHT TO USE "COLOR", APART FROM THE MARK AS SHOWN.

FOR HAIR CARE PREPARATIONS, NAMELY, HAIR COLOR AND HAIR CONDITIONER (U.S. CLS. 1, 4, 6, 50, 51 AND 52).

NICHOLAS COLEMAN, EXAMINING ATTORNEY

CLASS 3—(Continued).

SN 85-272,544. NEFELI CORP, PORT WASHINGTON, NY. FILED 3-21-2011.

Nefeli Adaptogenic Care

THE MARK CONSISTS OF STANDARD CHARACTERS WITHOUT CLAIM TO ANY PARTICULAR FONT, STYLE, SIZE, OR COLOR.

OWNER OF U.S. REG. NO. 2,896,379.

NO CLAIM IS MADE TO THE EXCLUSIVE RIGHT TO USE "ADAPTOGENIC CARE", APART FROM THE MARK AS SHOWN.

FOR AROMATIC BODY CARE PRODUCTS, NAMELY, BODY LOTION, SHOWER GEL, CUTICLE CREAM, SHAMPOO, CONDITIONER, NON-MEDICATED LIP BALM, SOAP, BODY POLISH, BODY AND FOOT SCRUB AND NON-MEDICATED FOOT CREAM; BEAUTY CREAMS; BEAUTY CREAMS FOR BODY CARE; BEAUTY GELS; BEAUTY LOTIONS; BEAUTY MASKS; BEAUTY SERUMS; BODY AND BEAUTY CARE COSMETICS; COSMETIC CREAMS FOR SKIN CARE; COSMETIC MASSAGE CREAMS; COSMETIC OILS; COSMETIC PREPARATIONS FOR BODY CARE; COSMETIC PREPARATIONS FOR SKIN CARE; COSMETIC PREPARATIONS FOR SKIN RENEWAL; COSMETIC PREPARATIONS, NAMELY, SKIN BALSAMS; COSMETICS; COSMETICS AND COSMETIC PREPARATIONS; COSMETICS AND MAKE-UP; COSMETICS, NAMELY, LIP REPAIRERS; EXFOLIANTS FOR SKIN, FACE; FACE AND BODY BEAUTY CREAMS; FACIAL BEAUTY MASKS; FACIAL CLEANSERS; FACIAL CLEANSING MILK; FACIAL CREAM; FACIAL CREAMS; FACIAL EMULSIONS; FACIAL LOTION; FACIAL MAKE-UP; FACIAL MASKS; FACIAL SCRUBS; FACIAL WASHES; FRAGRANCED BODY CARE PREPARATIONS, NAMELY, BODY LOTIONS, BODY CREAMS, BODY WASH, SHOWER GEL, BODY EXFOLIATORS/SCRUBS; FRAGRANCED FACE CARE PREPARATIONS, NAMELY, FACIAL CLEANSERS, FACIAL CREAMS, FACIAL LOTIONS, FACIAL TONERS, FACIAL EXFOLIATORS, FACIAL MOISTURIZERS, FACIAL MASKS,; FRAGRANCED FACIAL MOISTURIZER; FRAGRANCED SKIN CARE PREPARATIONS, NAMELY, SKIN CLEANERS, SKIN CREAMS, SKIN LOTIONS, SKIN MOISTURIZERS, SKIN EXFOLIATORS; HAIR CARE CREAMS; HAIR CARE LOTIONS; HAIR CARE PREPARATIONS; LOTIONS FOR COSMETIC PURPOSES; LOTIONS FOR FACE AND BODY CARE; LOTIONS FOR SKIN, FACE, BODY, HAIR; MASK PACK FOR COSMETIC PURPOSES; MOISTURIZING PREPARATIONS FOR THE SKIN; MOISTURIZING SOLUTIONS FOR THE SKIN; NON-MEDICATED BALMS FOR USE ON SKIN, LIPS; NON-MEDICATED CLEANSERS FOR PERSONAL USE, NAMELY, SKIN CLEANSERS, FACIAL CLEANSERS, BODY CLEANSERS; NON-MEDICATED CLEANSERS, NAMELY, SKIN CLEANSERS, FACIAL CLEANSERS, BODY CLEANSERS; NON-MEDICATED FACIAL AND EYE SERUM CONTAINING ANTIOXIDANTS; NON-MEDICATED HERBAL BODY CARE PRODUCTS, NAMELY, BODY OILS, SALVES, AND LIP BALMS; NON-MEDICATED HERBAL BODY CARE PRODUCTS, NAMELY, CREAMS, LOTIONS, WASH, EXFOLIATORS, OILS, MOISTURIZERS; NON-MEDICATED LIP CARE PREPARATIONS; NON-MEDICATED PREPARATIONS ALL FOR THE CARE OF SKIN, HAIR AND SCALP; NON-MEDICATED SERUMS FOR USE ON FACE, BODY, SKIN; NON-MEDICATED SKIN CARE CREAMS AND LOTIONS; NON-MEDICATED SKIN CARE PREPARATIONS; NON-MEDICATED SKIN CARE PREPARATIONS, NAMELY, CREAMS, LOTIONS, GELS, TONERS, CLEANERS AND PEELS; NON-MEDICATED SKIN CARE PREPARATIONS, NAMELY, CREAMS, LOTIONS, TONERS, CLEANERS, OILS, MOISTURIZERS, MASKS, EXFOLIATORS; NON-MEDICATED SKIN CREAMS; NON-MEDICATED SKIN TONERS; NON-MEDICATED STIMULATING LOTIONS FOR THE SKIN; NON-MEDICATED SKIN, HAIR, FACE CARE PREPARATIONS; PLANT AND HERB EXTRACTS SOLD AS COMPONENTS OF COSMETICS;

CLASS 3—(Continued).

PRE-MOISTENED COSMETIC TISSUES; SKIN AND BODY TOPICAL LOTIONS, CREAMS AND OILS FOR COSMETIC USE; SKIN CARE PREPARATION, NAMELY, BODY POLISH; SKIN CARE PRODUCTS, NAMELY, NON-MEDICATED SKIN SERUM; SKIN CLARIFIERS; SKIN CLEANSERS; SKIN CLEANSING CREAM; SKIN CLEANSING LOTION; SKIN CONDITIONERS; SKIN CONDITIONING CREAMS FOR COSMETIC PURPOSES; SKIN CREAM; SKIN CREAMS; SKIN EMOLLIENTS; SKIN LOTION; SKIN LOTIONS; SKIN MASKS; SKIN MOISTURIZER; SKIN MOISTURIZER MASKS; SKIN TONERS; WRINKLE REMOVING SKIN CARE PREPARATIONS (U.S. CLS. 1, 4, 6, 50, 51 AND 52).
HEATHER BIDDULPH, EXAMINING ATTORNEY

SN 85-272,554. NEFELI CORP, PORT WASHINGTON, NY.
FILED 3-21-2011.

Nefeli Adaptogenic Healing

THE MARK CONSISTS OF STANDARD CHARACTERS WITHOUT CLAIM TO ANY PARTICULAR FONT, STYLE, SIZE, OR COLOR.

OWNER OF U.S. REG. NO. 2,896,379.

NO CLAIM IS MADE TO THE EXCLUSIVE RIGHT TO USE "ADAPTOGENIC HEALING", APART FROM THE MARK AS SHOWN.

FOR AROMATIC BODY CARE PRODUCTS, NAMELY, BODY LOTION, SHOWER GEL, CUTICLE CREAM, SHAMPOO, CONDITIONER, NON-MEDICATED LIP BALM, SOAP, BODY POLISH, BODY AND FOOT SCRUB AND NON-MEDICATED FOOT CREAM; BEAUTY CREAMS; BEAUTY CREAMS FOR BODY CARE; BEAUTY GELS; BEAUTY LOTIONS; BEAUTY MILKS; BEAUTY SERUMS; BODY AND BEAUTY CARE COSMETICS; COSMETIC CREAMS FOR SKIN CARE; COSMETIC MASSAGE CREAMS; COSMETIC OILS; COSMETIC PREPARATIONS FOR BODY CARE; COSMETIC PREPARATIONS FOR SKIN CARE; COSMETIC PREPARATIONS FOR SKIN RENEWAL; COSMETIC PREPARATIONS, NAMELY, SKIN BALSAMS; COSMETICS; COSMETICS AND COSMETIC PREPARATIONS; COSMETICS AND MAKE-UP; COSMETICS, NAMELY, LIP REPAIRERS; EXFOLIANTS FOR SKIN, FACE; FACE AND BODY BEAUTY CREAMS; FACIAL BEAUTY MASKS; FACIAL CLEANSERS; FACIAL CLEANSING GRAINS; FACIAL CREAM; FACIAL CREAMS; FACIAL EMULSIONS; FACIAL LOTION; FACIAL MAKE-UP; FACIAL MASKS; FACIAL SCRUBS; FACIAL WASHES; FRAGRANCED BODY CARE PREPARATIONS, NAMELY, BODY LOTIONS, BODY CREAMS, BODY WASH, SHOWER GEL, BODY EXFOLIATORS/SCRUBS; FRAGRANCED FACE CARE PREPARATIONS, NAMELY, FACIAL CLEANSERS, FACIAL CREAMS, FACIAL LOTIONS, FACIAL TONERS, FACIAL EXFOLIATORS, FACIAL MOISTURIZERS, FACIAL MASKS; FRAGRANCED FACIAL MOISTURIZER; FRAGRANCED SKIN CARE PREPARATIONS, NAMELY, SKIN CLEANSERS, SKIN CREAMS, SKIN LOTIONS, SKIN MOISTURIZERS, SKIN EXFOLIATORS; HAIR CARE CREAMS; HAIR CARE LOTIONS; HAIR CARE PREPARATIONS; LOTIONS FOR COSMETIC PURPOSES; LOTIONS FOR FACE AND BODY CARE; LOTIONS FOR SKIN, FACE, BODY, HAIR; MASK PACK FOR COSMETIC PURPOSES; MOISTURIZING PREPARATIONS FOR THE SKIN; MOISTURIZING SOLUTIONS FOR THE SKIN; NON-MEDICATED BALMS FOR USE ON SKIN, LIPS; NON-MEDICATED CLEANSERS FOR PERSONAL USE, NAMELY, SKIN CLEANSERS, FACIAL CLEANSERS, BODY CLEANSERS; NON-MEDICATED CLEANSERS, NAMELY, SKIN CLEANSERS, FACIAL CLEANSERS, BODY CLEANSERS; NON-MEDICATED FACIAL AND EYE SERUM CONTAINING ANTIOXIDANTS; NON-MEDICATED HERBAL BODY CARE PRODUCTS, NAMELY, BODY OILS, SALVES,

CLASS 3—(Continued).

AND LIP BALMS; NON-MEDICATED HERBAL BODY CARE PRODUCTS, NAMELY, CREAMS, LOTIONS, WASH, EXFOLIATORS, OILS, MOISTURIZERS; NON-MEDICATED LIP CARE PREPARATIONS; NON-MEDICATED PREPARATIONS ALL FOR THE CARE OF SKIN, HAIR AND SCALP; NON-MEDICATED SERUMS FOR USE ON FACE, BODY, SKIN; NON-MEDICATED SKIN CARE CREAMS AND LOTIONS; NON-MEDICATED SKIN CARE PREPARATIONS; NON-MEDICATED SKIN CARE PREPARATIONS, NAMELY, CREAMS, LOTIONS, GELS, TONERS, CLEANERS AND PEELS; NON-MEDICATED SKIN CARE PREPARATIONS, NAMELY, CREAMS, LOTIONS, TONERS, CLEANSERS, OILS, MOISTURIZERS, MASKS, EXFOLIATORS; NON-MEDICATED SKIN CREAMS; NON-MEDICATED SKIN TONERS; NON-MEDICATED STIMULATING LOTIONS FOR THE SKIN; NON-MEDICATED SKIN, HAIR, FACE CARE PREPARATIONS; PLANT AND HERB EXTRACTS SOLD AS COMPONENTS OF COSMETICS; PRE-MOISTENED COSMETIC TISSUES; SKIN AND BODY TOPICAL LOTIONS, CREAMS AND OILS FOR COSMETIC USE; SKIN CARE PREPARATION, NAMELY, BODY POLISH; SKIN CARE PRODUCTS, NAMELY, NON-MEDICATED SKIN SERUM; SKIN CLARIFIERS; SKIN CLEANSERS; SKIN CLEANSING CREAM; SKIN CLEANSING LOTION; SKIN CONDITIONERS; SKIN CONDITIONING CREAMS FOR COSMETIC PURPOSES; SKIN CREAM; SKIN CREAMS; SKIN EMOLLIENTS; SKIN LOTION; SKIN LOTIONS; SKIN MASKS; SKIN MOISTURIZER; SKIN MOISTURIZER MASKS; SKIN TONERS; WRINKLE REMOVING SKIN CARE PREPARATIONS (U.S. CLS. 1, 4, 6, 50, 51 AND 52).
HEATHER BIDDULPH, EXAMINING ATTORNEY

SN 85-272,568. NEFELI CORP, PORT WASHINGTON, NY.
FILED 3-21-2011.

Tibetan Red

THE MARK CONSISTS OF STANDARD CHARACTERS WITHOUT CLAIM TO ANY PARTICULAR FONT, STYLE, SIZE, OR COLOR.

NO CLAIM IS MADE TO THE EXCLUSIVE RIGHT TO USE "TIBETAN", APART FROM THE MARK AS SHOWN.

FOR AROMATIC BODY CARE PRODUCTS, NAMELY, BODY LOTION, SHOWER GEL, CUTICLE CREAM, SHAMPOO, CONDITIONER, NON-MEDICATED LIP BALM, SOAP, BODY POLISH, BODY AND FOOT SCRUB AND NON-MEDICATED FOOT CREAM; BEAUTY CREAMS; BEAUTY CREAMS FOR BODY CARE; BEAUTY GELS; BEAUTY LOTIONS; BEAUTY MILKS; BEAUTY SERUMS; BODY AND BEAUTY CARE COSMETICS; COSMETIC CREAMS FOR SKIN CARE; COSMETIC MASSAGE CREAMS; COSMETIC OILS; COSMETIC PREPARATIONS FOR BODY CARE; COSMETIC PREPARATIONS FOR SKIN CARE; COSMETIC PREPARATIONS FOR SKIN RENEWAL; COSMETIC PREPARATIONS, NAMELY, SKIN BALSAMS; COSMETICS; COSMETICS AND COSMETIC PREPARATIONS; COSMETICS AND MAKE-UP; COSMETICS, NAMELY, LIP REPAIRERS; EXFOLIANTS FOR SKIN, FACE; FACE AND BODY BEAUTY CREAMS; FACIAL BEAUTY MASKS; FACIAL CLEANSERS; FACIAL CLEANSING GRAINS; FACIAL CREAM; FACIAL CREAMS; FACIAL EMULSIONS; FACIAL LOTION; FACIAL MAKE-UP; FACIAL MASKS; FACIAL SCRUBS; FACIAL WASHES; FRAGRANCED BODY CARE PREPARATIONS, NAMELY, BODY LOTIONS, BODY CREAMS, BODY WASH, SHOWER GEL, BODY EXFOLIATORS/SCRUBS; FRAGRANCED FACE CARE PREPARATIONS, NAMELY, FACIAL CLEANSERS, FACIAL CREAMS, FACIAL LOTIONS, FACIAL TONERS, FACIAL EXFOLIATORS, FACIAL MOISTURIZERS, FACIAL MASKS; FRAGRANCED FACIAL MOISTURIZER; FRAGRANCED SKIN CARE PREPARATIONS,

CLASS 3—(Continued).

NAMELY, SKIN CLEANSERS, SKIN CREAMS, SKIN LOTIONS, SKIN MOISTURIZERS, SKIN EXFOLIATORS; HAIR CARE CREAMS; HAIR CARE LOTIONS; HAIR CARE PREPARATIONS; LOTIONS FOR COSMETIC PURPOSES; LOTIONS FOR FACE AND BODY CARE; LOTIONS FOR SKIN, FACE, BODY, HAIR; MASK PACK FOR COSMETIC PURPOSES; MOISTURIZING PREPARATIONS FOR THE SKIN; MOISTURIZING SOLUTIONS FOR THE SKIN; NON-MEDICATED BALMS FOR USE ON SKIN, LIPS; NON-MEDICATED CLEANSERS FOR PERSONAL USE, NAMELY, SKIN CLEANSERS, FACIAL CLEANSERS, BODY CLEANSERS; NON-MEDICATED CLEANSERS, NAMELY, SKIN CLEANSERS, FACIAL CLEANSERS, BODY CLEANSERS; NON-MEDICATED FACIAL AND EYE SERUM CONTAINING ANTIOXIDANTS; NON-MEDICATED HERBAL BODY CARE PRODUCTS, NAMELY, BODY OILS, SALVES, AND LIP BALMS; NON-MEDICATED HERBAL BODY CARE PRODUCTS, NAMELY, CREAMS, LOTIONS, WASH, EXFOLIATORS, OILS, MOISTURIZERS; NON-MEDICATED LIP CARE PREPARATIONS; NON-MEDICATED PREPARATIONS ALL FOR THE CARE OF SKIN, HAIR AND SCALP; NON-MEDICATED SERUMS FOR USE ON FACE, BODY, SKIN; NON-MEDICATED SKIN CARE CREAMS AND LOTIONS; NON-MEDICATED SKIN CARE PREPARATIONS; NON-MEDICATED SKIN CARE PREPARATIONS, NAMELY, CREAMS, LOTIONS, GELS, TONERS, CLEANERS AND PEELS; NON-MEDICATED SKIN CARE PREPARATIONS, NAMELY, CREAMS, LOTIONS, TONERS, CLEANSERS, OILS, MOISTURIZERS, MASKS, EXFOLIATORS; NON-MEDICATED SKIN CREAMS; NON-MEDICATED SKIN TONERS; NON-MEDICATED STIMULATING LOTIONS FOR THE SKIN; NON-MEDICATED SKIN, HAIR, FACE CARE PREPARATIONS; PLANT AND HERB EXTRACTS SOLD AS COMPONENTS OF COSMETICS; PRE-MOISTENED COSMETIC TISSUES; SKIN AND BODY TOPICAL LOTIONS, CREAMS AND OILS FOR COSMETIC USE; SKIN CARE PREPARATION, NAMELY, BODY POLISH; SKIN CARE PRODUCTS, NAMELY, NON-MEDICATED SKIN SERUM; SKIN CLARIFIERS; SKIN CLEANSERS; SKIN CLEANSING CREAM; SKIN CLEANSING LOTION; SKIN CONDITIONERS; SKIN CONDITIONING CREAMS FOR COSMETIC PURPOSES; SKIN CREAM; SKIN CREAMS; SKIN EMOLLIENTS; SKIN LOTION; SKIN LOTIONS; SKIN MASKS; SKIN MOISTURIZER; SKIN MOISTURIZER MASKS; SKIN TONERS; WRINKLE REMOVING SKIN CARE PREPARATIONS (U.S. CLS. 1, 4, 6, 50, 51 AND 52).

HEATHER BIDDULPH, EXAMINING ATTORNEY

SN 85-272,634. NOVUS NATURAL PRODUCTS LLC., ORANGE, CA. FILED 3-21-2011.

ORALMAX ORAL RINSE

THE MARK CONSISTS OF STANDARD CHARACTERS WITHOUT CLAIM TO ANY PARTICULAR FONT, STYLE, SIZE, OR COLOR.

NO CLAIM IS MADE TO THE EXCLUSIVE RIGHT TO USE "ORAL RINSE", APART FROM THE MARK AS SHOWN.

FOR NON-MEDICATED MOUTH WASH AND RINSE (U.S. CLS. 1, 4, 6, 50, 51 AND 52).

FIRST USE 2-1-2011; IN COMMERCE 2-1-2011.

SANDRA BUJA, EXAMINING ATTORNEY

CLASS 3—(Continued).

SN 85-273,631. CENTRAL COAST LABS, INC., DBA CREO CARE, INC., GROVER BEACH, CA. FILED 3-22-2011.

CREO

THE MARK CONSISTS OF STANDARD CHARACTERS WITHOUT CLAIM TO ANY PARTICULAR FONT, STYLE, SIZE, OR COLOR.

THE ENGLISH TRANSLATION OF "CREO" IN THE MARK IS "CREATE".

FOR HAIR CARE PREPARATIONS, NAMELY, SHAMPOO AND CONDITIONER, SKIN CARE PREPARATIONS, NAMELY, BODY LOTION, FACIAL CLEANSER, BATH GEL, SOAP (U.S. CLS. 1, 4, 6, 50, 51 AND 52).

FIRST USE 2-1-2003; IN COMMERCE 4-1-2003.

GRETTA YAO, EXAMINING ATTORNEY

SN 85-274,518. SKINDINAVIA, INC, DBA SKINDINAVIA, CANTON, MA. FILED 3-23-2011.

NO MORE SHINE MAKEUP FINISH

THE MARK CONSISTS OF STANDARD CHARACTERS WITHOUT CLAIM TO ANY PARTICULAR FONT, STYLE, SIZE, OR COLOR.

OWNER OF U.S. REG. NOS. 3,750,918 AND 3,750,919.

NO CLAIM IS MADE TO THE EXCLUSIVE RIGHT TO USE "MAKEUP FINISH", APART FROM THE MARK AS SHOWN.

FOR OIL CONTROL MAKEUP SETTING SPRAY (U.S. CLS. 1, 4, 6, 50, 51 AND 52).

FIRST USE 12-14-2009; IN COMMERCE 12-14-2009.

REBECCA GILBERT, EXAMINING ATTORNEY

CLASS 3—(Continued).

SN 85-275,157. BASIC TRADEMARK S.A., LUXEMBOURG, LUXEMBOURG, FILED 3-23-2011.

KAPPA

THE MARK CONSISTS OF STANDARD CHARACTERS WITHOUT CLAIM TO ANY PARTICULAR FONT, STYLE, SIZE, OR COLOR.

OWNER OF ERPN CMNTY TM OFC REG. NO. 3137395, DATED 12-2-2004, EXPIRES 4-17-2013.

OWNER OF U.S. REG. NOS. 1,537,872, 3,313,051 AND OTHERS.

FOR HAIR LOTIONS, DENTIFRICES; PERFUMES, ESSENTIAL OILS FOR PERSONAL USE, COSMETICS, AFTER-SHAVE LOTIONS, AFTER-SHAVE BALMS, CLEANSING MILK, TALCUM POWDER, SUNSCREEN CREAMS, SKIN CLEANSERS, CREAMY FOUNDATIONS, TONERS, COSMETICS BEING COMPACTS, EYE SHADOWS, ROUGES, MASCARAS, SKIN CREAMS, EYE LINER AND LIP LINER, LIPSTICKS, SKIN LOTIONS, MAKE-UP POWDER, MAKE-UP REMOVING CREAMS AND LOTIONS, BEAUTY MASKS, NAIL CARE PREPARATIONS, NAIL POLISH REMOVERS, NAIL HARDENERS (U.S. CLS. 1, 4, 6, 50, 51 AND 52).

RUDY R. SINGLETON, EXAMINING ATTORNEY

SN 85-275,167. BASIC TRADEMARK S.A., LUXEMBOURG, LUXEMBOURG, FILED 3-23-2011.



OWNER OF ERPN CMNTY TM OFC REG. NO. 1847649, DATED 12-11-2001, EXPIRES 9-11-2020.

OWNER OF U.S. REG. NOS. 1,535,394, 3,043,005 AND OTHERS.

THE MARK CONSISTS OF SILHOUETTES OF A MAN AND A WOMAN SITTING BACK TO BACK.

FOR HAIR LOTIONS, DENTIFRICES; PERFUMES, ESSENTIAL OILS FOR PERSONAL USE, COSMETICS, SOAPS FOR BODY CARE, AFTER-SHAVE LOTIONS, AFTER-SHAVE BALMS, CLEANSING MILK, TALCUM POWDER, SUNSCREEN CREAMS, SKIN CLEANSERS, CREAMY FOUNDATIONS, TONERS, COSMETICS BEING COMPACTS, EYE SHADOWS, ROUGES, MASCARAS, SKIN CREAMS, EYE LINER AND LIP LINER, LIPSTICKS, SKIN LOTIONS, MAKE-UP POWDER, MAKE-UP REMOVING CREAMS AND LOTIONS, BEAUTY MASKS, NAIL CARE PREPARATIONS, NAIL POLISH REMOVERS, NAIL HARDENERS (U.S. CLS. 1, 4, 6, 50, 51 AND 52).

RUDY R. SINGLETON, EXAMINING ATTORNEY

CLASS 3—(Continued).

SN 85-279,729. BILLY G. LASTER JR., GARY, IN. FILED 3-29-2011.

Decadent Dulcet

THE MARK CONSISTS OF STANDARD CHARACTERS WITHOUT CLAIM TO ANY PARTICULAR FONT, STYLE, SIZE, OR COLOR.

FOR COSMETICS IN GENERAL, INCLUDING PERFUMES (U.S. CLS. 1, 4, 6, 50, 51 AND 52).

SOPHIA S. KIM, EXAMINING ATTORNEY

SN 85-281,813. AMERICA ASIA RESOURCES, INC., HUNTINGTON BEACH, CA. FILED 3-30-2011.



THE MARK CONSISTS OF A DESIGN OF THE LETTERS "AAR" WITH A CURVED LINE THROUGHOUT THE LETTERS.

FOR AROMATIC ESSENTIAL OILS; AROMATIC OILS; AROMATIC POTPOURRIS; COSMETICS; ESSENTIAL OILS; FRAGRANCES; PERFUMES; PERFUMES FOR INDUSTRIAL PURPOSES (U.S. CLS. 1, 4, 6, 50, 51 AND 52).

KARANENDRA S. CHHINA, EXAMINING ATTORNEY

SN 85-288,840. WINDMILL HEALTH PRODUCTS, LLC, WEST CALDWELL, NJ. FILED 4-7-2011.

LASER LOTION HAIR REMOVAL

THE MARK CONSISTS OF STANDARD CHARACTERS WITHOUT CLAIM TO ANY PARTICULAR FONT, STYLE, SIZE, OR COLOR.

NO CLAIM IS MADE TO THE EXCLUSIVE RIGHT TO USE "LOTION" AND "HAIR REMOVAL", APART FROM THE MARK AS SHOWN.

FOR HAIR REMOVING CREAM (U.S. CLS. 1, 4, 6, 50, 51 AND 52).

LINDA POWELL, EXAMINING ATTORNEY

CLASS 3—(Continued).

SN 85-289,984. CGE ENTERPRISES LLC, MANCHESTER CENTER, VT. FILED 4-8-2011.

LUSTRE-CREME

THE MARK CONSISTS OF STANDARD CHARACTERS WITHOUT CLAIM TO ANY PARTICULAR FONT, STYLE, SIZE, OR COLOR.

NO CLAIM IS MADE TO THE EXCLUSIVE RIGHT TO USE "CREME", APART FROM THE MARK AS SHOWN.

FOR HAIR SHAMPOO (U.S. CLS. 1, 4, 6, 50, 51 AND 52).

FIRST USE 2-15-2010; IN COMMERCE 2-15-2010.
TOBY BULLOFF, EXAMINING ATTORNEY

SN 85-290,186. PERFUMELAND OF ORLANDO, INC, ORLANDO, FL. FILED 4-8-2011.

TRIGGER-DAVERB

THE MARK CONSISTS OF STANDARD CHARACTERS WITHOUT CLAIM TO ANY PARTICULAR FONT, STYLE, SIZE, OR COLOR.

FOR COLOGNE, PERFUME OIL SPRAY, AFTER SHAVE BALM, BODY MOISTURIZING LOTION, BODY CREME, DUSTING POWDER, BATH AND SHOWER GEL, SOAP, BATH AND BODY OIL, ANTIPERSPIRANT AND BATH SALTS (U.S. CLS. 1, 4, 6, 50, 51 AND 52).

DOMINICK J. SALEMI, EXAMINING ATTORNEY

CLASS 3—(Continued).

SN 85-290,249. SCULPT COSMETICS CORPORATION, DBA SCULPT, VANCOUVER, CANADA, FILED 4-8-2011.

SCULPT.
SCULPT.

THE MARK CONSISTS OF THE WORD "SCULPT" AND A DOT AT THE END, APPEARING EITHER HORIZONTALLY OR VERTICALLY, IN BLOCK LETTERS.

FOR ANTIBACTERIAL SKIN SOAPS; AROMATIC BODY CARE PRODUCTS, NAMELY, BODY LOTION, SHOWER GEL, CUTICLE CREAM, SHAMPOO, CONDITIONER, NON-MEDICATED LIP BALM, SOAP, BODY POLISH, BODY AND FOOT SCRUB AND NON-MEDICATED FOOT CREAM; BEAUTY CREAMS FOR BODY CARE; BODY AND BEAUTY CARE COSMETICS; CLOTHS OR TISSUES IMPREGNATED WITH A SKIN CLEANSER; CONDITIONERS; COSMETIC CREAMS FOR SKIN CARE; COSMETIC PREPARATIONS FOR BODY CARE; COSMETIC PREPARATIONS FOR PROTECTING THE SKIN FROM THE SUN'S RAYS; COSMETIC PREPARATIONS FOR SKIN CARE; COSMETIC PREPARATIONS FOR SKIN RENEWAL; COSMETIC PREPARATIONS, NAMELY, SKIN BALSAMS; COSMETIC PRODUCTS IN THE FORM OF AEROSOLS FOR SKIN CARE; COSMETIC PRODUCTS IN THE FORM OF AEROSOLS FOR SKINCARE; COSMETIC SKIN FRESHENERS; HAIR CARE CREAMS; HAIR CARE LOTIONS; HAIR CARE PREPARATIONS; HAIR CARE PREPARATIONS CONSISTING OF ORGANIC COCONUT VIRGIN OIL AND COCONUT VIRGIN OIL; HAIR CARE PRODUCTS, NAMELY, HEAT PROTECTION SPRAYS; LOTIONS FOR FACE AND BODY CARE; MOISTURIZING PREPARATIONS FOR THE SKIN; MOISTURIZING SOLUTIONS FOR THE SKIN; NAIL CARE KITS COMPRISING NAIL POLISH; NAIL CARE PREPARATIONS; NAIL CARE PREPARATIONS, NAMELY, NAIL SOFTENERS; NATURAL COCOA BUTTER BASED PERSONAL CARE PRODUCTS, NAMELY, BODY LOTION, SHOWER GEL, SOAP, BODY POLISH, BODY AND FOOT SCRUB AND NON-MEDICATED SKIN CREAMS; NON-MEDICATED COSMETIC SKIN CARE PREPARATIONS CONSISTING OF ORGANIC COCONUT VIRGIN OIL AND COCONUT VIRGIN OIL; NON-MEDICATED HERBAL BODY CARE PRODUCTS, NAMELY, BODY OILS, SALVES, AND LIP BALMS; NON-MEDICATED LIP CARE PREPARATIONS; NON-MEDICATED PREPARATIONS ALL FOR THE CARE OF SKIN, HAIR AND SCALP; NON-MEDICATED SKIN CARE CREAMS AND LOTIONS; NON-MEDICATED SKIN CARE PREPARATION, NAMELY, BODY MIST; NON-MEDICATED SKIN CARE PREPARATIONS; NON-MEDICATED SKIN CARE PREPARATIONS, NAMELY, CREAMS, LOTIONS, GELS, TONERS, CLEANSERS AND PEELS; NON-MEDICATED SKIN CREAM FOR GENERAL SKIN RASH AND IRRITATION RESULTING FROM SKIN SHINGLES; NON-MEDICATED SKIN CREAMS; NON-MEDICATED SKIN CREAMS WITH ESSENTIAL OILS FOR USE IN AROMATHERAPY; NON-MEDICATED SKIN TONERS; NON-MEDICATED STIMULATING LOTIONS FOR THE SKIN; NON-MEDICATED SUN CARE PREPARATIONS; OIL BATHS FOR HAIR CARE; PATCHES CONTAINING SUN SCREEN AND SUN BLOCK FOR USE ON THE SKIN; SKIN ABRASIVE PREPARATIONS; SKIN AND BODY TOPICAL LOTIONS, CREAMS AND OILS FOR COSMETIC USE; SKIN BRONZER; SKIN BRONZING CREAMS; SKIN CARE PREPARATION, NAMELY, BODY POLISH; SKIN CARE PREPARATIONS, NAMELY,

CLASS 3—(Continued).

BODY BALM; SKIN CARE PREPARATIONS, NAMELY, CHEMICAL PEELS FOR SKIN; SKIN CARE PREPARATIONS, NAMELY, FRUIT ACID PEELS FOR SKIN; SKIN CARE PREPARATIONS, NAMELY, SKIN PEELS; SKIN CARE PRODUCTS, NAMELY, NON-MEDICATED SKIN SERUM; SKIN CLARIFIERS; SKIN CLEANSER IN LIQUID SPRAY FORM FOR USE AS A BABY WIPE ALTERNATIVE; SKIN CLEANSERS; SKIN CLEANSING CREAM; SKIN CLEANSING LOTION; SKIN CONDITIONERS; SKIN CONDITIONING CREAMS FOR COSMETIC PURPOSES; SKIN CREAM; SKIN CREAMS; SKIN CREAMS IN LIQUID AND IN SOLID FORM; SKIN CREAMS IN LIQUID AND SOLID; SKIN CREAMS IN LIQUID AND SOLID FORM; SKIN EMOLLIENTS; SKIN FRESHENERS; SKIN GELS FOR ACCELERATING, ENHANCING OR EXTENDING TANS; SKIN LIGHTENERS; SKIN LIGHTENING CREAMS; SKIN LOTION; SKIN LOTIONS; SKIN MASKS; SKIN MOISTURIZER; SKIN MOISTURIZER MASKS; SKIN MOISTURIZING GEL; SKIN POLISHING RICE BRAN (ARAI-NUKA); SKIN SOAP; SKIN TEXTURIZERS; SKIN TONERS; SKIN WHITENING CREAMS; SKIN WHITENING PREPARATIONS; SOAPS FOR BODY CARE; SUN CARE LOTIONS; TOPICAL SKIN SPRAYS FOR COSMETIC PURPOSES; WIPES IMPREGNATED WITH A SKIN CLEANSER; WRINKLE REMOVING SKIN CARE PREPARATIONS (U.S. CLS. 1, 4, 6, 50, 51 AND 52).

FIRST USE 8-17-2010; IN COMMERCE 8-17-2010.
 NAAKWAMA ANKRAH, EXAMINING ATTORNEY

SN 85-290,282. JULIE-ANNE SELVEY, MOUNT VERNON, NY. FILED 4-8-2011.

Skull & Bones

THE MARK CONSISTS OF STANDARD CHARACTERS WITHOUT CLAIM TO ANY PARTICULAR FONT, STYLE, SIZE, OR COLOR.

FOR AFTER SHAVE BALMS; AFTER SHAVE GELS; AFTER SHAVE LOTIONS; COLOGNE, DEODORANT FOR PERSONAL USE; DEODORANT SOAP; EAU DE COLOGNE; EAU DE PARFUM; EAU DE TOILETTE; PERFUME; PERFUMED SOAP; SHAVING BALM; SHAVING CREAM; SHAVING FOAM; SHAVING GEL; SHAVING LOTION; SHAVING SOAP; SHOWER AND BATH GEL; SKIN LOTION; BODY LOTION; PERFUMED BODY SPRAY; BODY WASHES; HAIR SHAMPOO; HAIR CONDITIONER; HAIR GEL; HAIR CREAMS; HAIR PO-MADE, COSMETICS (U.S. CLS. 1, 4, 6, 50, 51 AND 52).

RAMONA ORTIGA, EXAMINING ATTORNEY

CLASS 3—(Continued).

SN 85-290,555. SCIENTIFIC ESSENTIALS INC., ST. JAMES, NY. FILED 4-8-2011.

SIMPLY SCIENTIFIC

THE MARK CONSISTS OF STANDARD CHARACTERS WITHOUT CLAIM TO ANY PARTICULAR FONT, STYLE, SIZE, OR COLOR.

FOR 3-IN-1 HAIR CONDITIONERS; 3-IN-1 HAIR SHAMPOOS; AFTER-SHAVE LOTIONS; AFTER-SUN LOTIONS; AFTERSHAVE; AGE RETARDANT GEL; AGE RETARDANT LOTION; AGE SPOT REDUCING CREAMS; ANTI-AGING CLEANSER; ANTI-AGING CREAM; ANTI-AGING CREAM CONTAINING A RETINOIC INGREDIENT NOT FOR MEDICAL PURPOSES; ANTI-AGING CREAMS; ANTI-AGING MOISTURIZER; ANTI-AGING TONER; ANTIBACTERIAL SKIN SOAPS; ANTIBACTERIAL SOAP; ANTIPERSPIRANTS AND DEODORANTS FOR PERSONAL USE; BABY HAIR CONDITIONER; BATH AND SHOWER GELS AND SALTS NOT FOR MEDICAL PURPOSES; BATH OIL; BEAUTY CREAMS; BEAUTY CREAMS FOR BODY CARE; BEAUTY GELS; BEAUTY LOTIONS; BEAUTY MASKS; BEAUTY SERUMS; BLUSH; BODY AND BEAUTY CARE COSMETICS; BUBBLE BATH; COLOGNES, PERFUMES AND COSMETICS; COSMETIC HAIR DRESSING PREPARATIONS; COSMETIC HAIR FILLING POWDERS FOR COVERING BALD AND THINNING SPOTS ON THE SCALP; COSMETIC HAIR REGROWTH INHIBITING PREPARATIONS; COSMETIC PREPARATIONS FOR BATH AND SHOWER; COSMETIC PREPARATIONS FOR PROTECTING THE SKIN FROM THE SUN'S RAYS; COSMETIC PREPARATIONS FOR SKIN CARE; COSMETIC PREPARATIONS FOR THE HAIR AND SCALP; COSMETIC PREPARATIONS, NAMELY, FIRMING CREAMS; COSMETIC PREPARATIONS, NAMELY, FIRMING LOTIONS; COSMETICS AND MAKE-UP; DRY SHAMPOOS; EXFOLIANTS FOR SKIN; EXFOLIATING PAD CONTAINING A GLYCOLIC INGREDIENT NOT FOR MEDICAL PURPOSES; EYE CREAM; EYE LINER; EYE LOTIONS; EYE MAKE-UP; EYE-SHADOW; EYEBROW COLORS; EYEBROW COSMETICS; EYEBROW PENCILS; EYELINER; EYELINERS; EYES MAKE-UP; FACE AND BODY GLITTER; FACE AND BODY LOTIONS; FACE CREAMS AND CLEANSERS CONTAINING BENZOYL PEROXIDE FOR COSMETIC PURPOSES; FACIAL CLEANSERS; FACIAL CONCEALER; FACIAL MAKE-UP; FACIAL MOISTURIZER WITH SPF; FOAM CLEANSERS FOR PERSONAL USE; FOAMS CONTAINING COSMETICS AND SUNSCREENS; FRAGRANCED BODY CARE PREPARATIONS, NAMELY, BODY AND SHOWER GELS; FRAGRANCED FACE CARE PREPARATIONS, NAMELY, FACIAL CLEANSERS, FACIAL MOISTURIZERS; HAIR CARE CREAMS; HAIR CARE KITS COMPRISING NON-MEDICATED HAIR CARE PREPARATIONS, NAMELY, SHAMPOO AND CONDITIONER; HAIR CARE LOTIONS; HAIR CARE PREPARATIONS; HAIR CARE PRODUCTS, NAMELY, HEAT PROTECTION SPRAYS; HAIR CLEANING PREPARATIONS; HAIR COLORING PREPARATIONS; HAIR CONDITIONER; HAIR CONDITIONERS; HAIR FIXERS; HAIR GEL; HAIR GEL AND HAIR MOUSSE; HAIR GELS; HAIR GLAZE; HAIR LOTION; HAIR LOTIONS; HAIR NOURISHERS; HAIR OILS; HAIR SHAMPOO; HAIR SHAMPOOS AND CONDITIONERS; HAIR SHEEN SPRAY; HAIR SPRAY; HAIR SPRAYS; HAIR SPRAYS AND HAIR GELS; HAIR STYLING GEL; HAIR STYLING PREPARATIONS; HAIR WAVING LOTION; HAIR WAVING PREPARATIONS; HAIR WAX; LIP GLOSS; LIP LINER; LIP POLISHER; LIPSTICK; LIQUID SOAPS FOR HANDS, FACE AND BODY; LOTIONS FOR HAIR WAVING; MAKE-UP FOR THE FACE AND BODY; MAKE-UP POWDER; MAKE-UP PREPARATIONS; MAKE-UP PREPARATIONS FOR THE FACE AND BODY; MASSAGE CREAMS; MASSAGE GELS OTHER THAN FOR MEDICAL PURPOSES;

CLASS 3—(Continued).

MOISTURIZING CREAMS; MOISTURIZING SOLUTIONS FOR THE SKIN; NON-MEDICATED ANTI-AGING SERUM; NON-MEDICATED HAIR SERUMS; NON-MEDICATED SKIN CARE PREPARATIONS, NAMELY, CREAMS, LOTIONS, GELS, TONERS, CLEANSERS AND PEELS; NUTRITIONAL OILS FOR COSMETIC PURPOSES; PREPARATIONS FOR SETTING HAIR; RETINOL CREAM FOR COSMETIC PURPOSES; SKIN CARE PRODUCTS, NAMELY, NON-MEDICATED SKIN SERUM; SKIN TONERS; SUN BLOCK PREPARATIONS; SUN CARE LOTIONS (U.S. CLS. 1, 4, 6, 50, 51 AND 52).

JAY BESCH, EXAMINING ATTORNEY

SN 85-290,563. UNILEVER SUPPLY CHAIN, INC., CLINTON, CT. FILED 4-8-2011.

SPORT BLAST

THE MARK CONSISTS OF STANDARD CHARACTERS WITHOUT CLAIM TO ANY PARTICULAR FONT, STYLE, SIZE, OR COLOR.

FOR PERSONAL DEODORANTS, BODY WASH AND SHOWER GEL (U.S. CLS. 1, 4, 6, 50, 51 AND 52).

KATINA MISTER, EXAMINING ATTORNEY

SN 85-290,978. TERRAKEM, INC., MIAMI, FL. FILED 4-9-2011.

FoamStix

THE MARK CONSISTS OF STANDARD CHARACTERS WITHOUT CLAIM TO ANY PARTICULAR FONT, STYLE, SIZE, OR COLOR.

FOR SOAP STICKS FOR USE BY THE OIL AND GAS INDUSTRIES FOR INJECTING DIRECTLY INTO OIL AND GAS WELLS SO THAT EXCESS WATER CAN FOAM OUT AND BE ELIMINATED FROM THE WELLS (U.S. CLS. 1, 4, 6, 50, 51 AND 52).

PATRICIA EVANKO, EXAMINING ATTORNEY

SN 85-291,673. KOLOS, EDWARD, STUART, FL. FILED 4-11-2011.

Nasalzyme

THE MARK CONSISTS OF STANDARD CHARACTERS WITHOUT CLAIM TO ANY PARTICULAR FONT, STYLE, SIZE, OR COLOR.

FOR TOPICAL SKIN SPRAYS FOR COSMETIC PURPOSES (U.S. CLS. 1, 4, 6, 50, 51 AND 52).

EDWARD NELSON, EXAMINING ATTORNEY

CLASS 3—(Continued).

SN 85-291,708. KOLOS, EDWARD, STUART, FL. FILED 4-11-2011.

Sea Life

THE MARK CONSISTS OF STANDARD CHARACTERS WITHOUT CLAIM TO ANY PARTICULAR FONT, STYLE, SIZE, OR COLOR.

FOR BODY CREAMS; SKIN MOISTURIZING GEL; SUN TAN GEL; SUNSCREEN CREAMS (U.S. CLS. 1, 4, 6, 50, 51 AND 52).

EDWARD NELSON, EXAMINING ATTORNEY

SN 85-292,055. THE ARK OF SALVATION, ATLANTA, GA. FILED 4-11-2011.

GOD HEALS

THE MARK CONSISTS OF STANDARD CHARACTERS WITHOUT CLAIM TO ANY PARTICULAR FONT, STYLE, SIZE, OR COLOR.

FOR ESSENTIAL OILS FOR PERSONAL USE (U.S. CLS. 1, 4, 6, 50, 51 AND 52).

FIRST USE 8-19-2007; IN COMMERCE 8-19-2007.

JANICE L. MCMORROW, EXAMINING ATTORNEY

SN 85-292,197. THE DIAL CORPORATION, SCOTTSDALE, AZ. FILED 4-11-2011.

CLEAR DEFENSE

THE MARK CONSISTS OF STANDARD CHARACTERS WITHOUT CLAIM TO ANY PARTICULAR FONT, STYLE, SIZE, OR COLOR.

NO CLAIM IS MADE TO THE EXCLUSIVE RIGHT TO USE "CLEAR", APART FROM THE MARK AS SHOWN.

FOR DEODORANTS AND ANTIPERSPIRANTS FOR PERSONAL USE (U.S. CLS. 1, 4, 6, 50, 51 AND 52).

JAMES LOVELACE, EXAMINING ATTORNEY

CLASS 3—(Continued).

SN 85-292,202. THE DIAL CORPORATION, SCOTTSDALE, AZ. FILED 4-11-2011.

ATTRACTION ENHANCING

THE MARK CONSISTS OF STANDARD CHARACTERS WITHOUT CLAIM TO ANY PARTICULAR FONT, STYLE, SIZE, OR COLOR.

FOR DEODORANTS AND ANTIPERSPIRANTS FOR PERSONAL USE (U.S. CLS. 1, 4, 6, 50, 51 AND 52).
JAMES LOVELACE, EXAMINING ATTORNEY

SN 85-292,351. SHADOW TANS INTERNATIONAL L.L.C., OVIEDO, FL. FILED 4-11-2011.

SHADOW TANS

THE MARK CONSISTS OF STANDARD CHARACTERS WITHOUT CLAIM TO ANY PARTICULAR FONT, STYLE, SIZE, OR COLOR.

NO CLAIM IS MADE TO THE EXCLUSIVE RIGHT TO USE "TANS", APART FROM THE MARK AS SHOWN.

FOR TANNING SOLUTIONS, NAMELY, TANNING CREAMS; TANNING PRODUCTS, NAMELY, SUN TANNING PREPARATIONS AND SELF-TANNING PREPARATIONS; TANNING SYSTEMS, NAMELY, SKIN GELS FOR ACCELERATING, ENHANCING OR EXTENDING TANS AND SUN TANNING PREPARATIONS ALL SOLD TOGETHER AS A UNIT; SKIN MOISTURIZERS; BODY LOTIONS; EXFOLIATING PRODUCTS, NAMELY, EXFOLIANT CREAMS (U.S. CLS. 1, 4, 6, 50, 51 AND 52).

FIRST USE 0-0-2004; IN COMMERCE 0-0-2004.
BRENDAN MCCAULEY, EXAMINING ATTORNEY

SN 85-292,567. THE TRUSTEE OF THE HADLEY NAGEL TRUST, NEW YORK, NY. FILED 4-12-2011.

ALE BAIT

THE MARK CONSISTS OF STANDARD CHARACTERS WITHOUT CLAIM TO ANY PARTICULAR FONT, STYLE, SIZE, OR COLOR.

FOR PERFUMES, COLOGNES AND FRAGRANCES (U.S. CLS. 1, 4, 6, 50, 51 AND 52).

SHANNON TWOHIG, EXAMINING ATTORNEY

CLASS 3—(Continued).

SN 85-292,666. RICHARD DAVIDSON, DELRAY BEACH, FL. FILED 4-12-2011.

FOXO

THE MARK CONSISTS OF STANDARD CHARACTERS WITHOUT CLAIM TO ANY PARTICULAR FONT, STYLE, SIZE, OR COLOR.

FOR ANTIBACTERIAL SKIN SOAPS; AROMATIC BODY CARE PRODUCTS, NAMELY, BODY LOTION, SHOWER GEL, CUTICLE CREAM, SHAMPOO, CONDITIONER, NON-MEDICATED LIP BALM, SOAP, BODY POLISH, BODY AND FOOT SCRUB AND NON-MEDICATED FOOT CREAM; BEAUTY CREAMS FOR BODY CARE; BODY AND BEAUTY CARE COSMETICS; CLOTHS OR TISSUES IMPREGNATED WITH A SKIN CLEANSER; CONCEALERS FOR SKIN; CONDITIONERS; COSMETIC CREAMS FOR SKIN CARE; COSMETIC PREPARATIONS FOR BODY CARE; COSMETIC PREPARATIONS FOR PROTECTING THE SKIN FROM THE SUN'S RAYS; COSMETIC PREPARATIONS FOR SKIN CARE; COSMETIC PREPARATIONS FOR SKIN RENEWAL; COSMETIC PREPARATIONS FOR THE CARE OF MOUTH AND TEETH; COSMETIC PREPARATIONS, NAMELY, SKIN BALSAMS; COSMETIC PRODUCTS IN THE FORM OF AEROSOLS FOR SKIN CARE; COSMETIC PRODUCTS IN THE FORM OF AEROSOLS FOR SKINCARE; COSMETIC PRODUCTS TAKEN ORALLY, NAMELY, PILLS THAT INDUCE BRONZING OF THE SKIN; COSMETIC SKIN FRESHENERS; DECORATIVE TRANSFERS AND SKIN JEWELS FOR COSMETIC PURPOSES; DEODORANTS FOR BODY CARE; EXFOLIANTS FOR SKIN; FRAGRANCED BODY CARE PREPARATIONS, NAMELY, BOBY SCRUBS, SHOWER GELS; FRAGRANCED FACE CARE PREPARATIONS, NAMELY, FACIAL CLEANSERS, FACIAL MOISTURIZERS; FRAGRANCED SKIN CARE PREPARATIONS, NAMELY, SKIN CLEANSERS, SKIN MOISTURIZERS; HAIR CARE CREAMS; HAIR CARE KITS COMPRISING NON-MEDICATED HAIR CARE PREPARATIONS, NAMELY, SHAMPOO, CONDITIONER, GEL; HAIR CARE LOTIONS; HAIR CARE PREPARATIONS; HAIR CARE PREPARATIONS CONSISTING OF ORGANIC COCONUT VIRGIN OIL AND COCONUT VIRGIN OIL; HAIR CARE PRODUCTS, NAMELY, HEAT PROTECTION SPRAYS; HOME DENTAL CARE PRODUCTS FOR DOGS AND CATS, NAMELY, NON-MEDICATED DENTAL SPRAY; HOME DENTAL CARE PRODUCTS FOR DOGS AND CATS, NAMELY, TOOTHPASTE; LOTIONS FOR FACE AND BODY CARE; LOTIONS FOR SKIN, HAIR, FACE, BODY, HAIR WAVING; MOISTURIZING PREPARATIONS FOR THE SKIN; MOISTURIZING SOLUTIONS FOR THE SKIN; MOUSSE FOR HAIR, SKIN, FACIAL; NAIL CARE KITS COMPRISING NAIL POLISH; NAIL CARE PREPARATIONS; NAIL CARE PREPARATIONS, NAMELY, NAIL SOFTENERS; NATURAL COCOA BUTTER BASED PERSONAL CARE PRODUCTS, NAMELY, BODY LOTION, SHOWER GEL, SOAP, BODY POLISH, BODY AND FOOT SCRUB AND NON-MEDICATED SKIN CREAMS; NON-MEDICATED BALMS FOR USE ON HAIR, SKIN, LIPS; NON-MEDICATED CLEANSERS FOR PERSONAL USE, NAMELY, SKIN CLEANSERS, FACIAL CLEANSERS; NON-MEDICATED CLEANSERS, NAMELY, SKIN CLEANSERS, FACIAL CLEANSERS; NON-MEDICATED COSMETIC SKIN CARE PREPARATIONS CONSISTING OF ORGANIC COCONUT VIRGIN OIL AND COCONUT VIRGIN OIL; NON-MEDICATED HERBAL BODY CARE PRODUCTS, NAMELY, BODY OILS, SALVES, AND LIP BALMS; NON-MEDICATED HERBAL BODY CARE PRODUCTS, NAMELY, SKIN CLEANSERS, FACIAL CLEANSERS, SHAMPOO, GELS; NON-MEDICATED LIP CARE PREPARATIONS; NON-MEDICATED PREPARATIONS ALL FOR THE CARE OF SKIN, HAIR AND SCALP; NON-MEDICATED SERUMS FOR USE ON HAIR, SKIN, LIPS; NON-MEDICATED SKIN CARE CREAMS AND LOTIONS; NON-MEDICATED SKIN CARE PREPARATION, NAMELY, BODY MIST; NON-MEDICATED SKIN CARE PREPARATIONS; NON-

CLASS 3—(Continued).

MEDICATED SKIN CARE PREPARATIONS, NAMELY, CREAMS, LOTIONS, GELS, TONERS, CLEANERS AND PEELS; NON-MEDICATED SKIN CARE PREPARATIONS, NAMELY, CREAMS, LOTIONS, GELS, TONERS, CLEANSERS, PEELS; NON-MEDICATED SKIN CREAM FOR GENERAL SKIN RASH AND IRRITATION RESULTING FROM SKIN SHINGLES; NON-MEDICATED SKIN CREAMS; NON-MEDICATED SKIN CREAMS WITH ESSENTIAL OILS FOR USE IN AROMATHERAPY; NON-MEDICATED SKIN TONERS; NON-MEDICATED STIMULATING LOTIONS FOR THE SKIN; NON-MEDICATED SUN CARE PREPARATIONS; NON-MEDICATED SKIN, HAIR, NAIL CARE PREPARATIONS; OIL BATHS FOR HAIR CARE; PATCHES CONTAINING SUN SCREEN AND SUN BLOCK FOR USE ON THE SKIN; PET CARE KITS COMPRISING SHAMPOO, CONDITIONER, BODY SPRAY; SEAWATER-BASED SKIN CARE PREPARATIONS FOR SKIN RENEWAL; SKIN ABRASIVE PREPARATIONS; SKIN AND BODY TOPICAL LOTIONS, CREAMS AND OILS FOR COSMETIC USE; SKIN BRONZER; SKIN BRONZING CREAMS; SKIN CARE PREPARATION, NAMELY, BODY POLISH; SKIN CARE PREPARATIONS, NAMELY, BODY BALM; SKIN CARE PREPARATIONS, NAMELY, CHEMICAL PEELS FOR SKIN; SKIN CARE PREPARATIONS, NAMELY, FRUIT ACID PEELS FOR SKIN; SKIN CARE PREPARATIONS, NAMELY, SKIN PEELS; SKIN CARE PRODUCTS, NAMELY, NON-MEDICATED SKIN SERUM; SKIN CLARIFIERS; SKIN CLEANSER IN LIQUID SPRAY FORM FOR USE AS A BABY WIPE ALTERNATIVE; SKIN CLEANSERS; SKIN CLEANSING CREAM; SKIN CLEANSING LOTION; SKIN CONDITIONERS; SKIN CONDITIONING CREAMS FOR COSMETIC PURPOSES; SKIN CREAM; SKIN CREAMS; SKIN CREAMS IN LIQUID AND IN SOLID FORM; SKIN CREAMS IN LIQUID AND SOLID; SKIN CREAMS IN LIQUID AND SOLID FORM; SKIN EMOLLIENTS; SKIN FRESHENERS; SKIN GELS FOR ACCELERATING, ENHANCING OR EXTENDING TANS; SKIN LIGHTENERS; SKIN LIGHTENING CREAMS; SKIN LOTION; SKIN LOTIONS; SKIN MASKS; SKIN MOISTURIZER; SKIN MOISTURIZER MASKS; SKIN MOISTURIZING GEL; SKIN POLISHING RICE BRAN (ARAI-NUKA); SKIN SOAP; SKIN TEXTURIZERS; SKIN TONERS; SKIN WHITENING CREAMS; SKIN WHITENING PREPARATIONS; SOAPS FOR BODY CARE; SUN CARE LOTIONS; TOPICAL SKIN SPRAYS FOR COSMETIC PURPOSES; WIPES IMPREGNATED WITH A SKIN CLEANSER; WRINKLE REMOVING SKIN CARE PREPARATIONS (U.S. CLS. 1, 4, 6, 50, 51 AND 52).

RONALD MCMORROW, EXAMINING ATTORNEY

SN 85-292,783. WOLF IN SHEEP'S CLOTHING, LLC, HOBOKEN, NJ. FILED 4-12-2011.

United Scents of America

THE MARK CONSISTS OF STANDARD CHARACTERS WITHOUT CLAIM TO ANY PARTICULAR FONT, STYLE, SIZE, OR COLOR.

NO CLAIM IS MADE TO THE EXCLUSIVE RIGHT TO USE "SCENTS OF AMERICA", APART FROM THE MARK AS SHOWN.

FOR BEAUTY PRODUCTS, NAMELY, COLOGNES, PERFUMES, DISINFECTING PERFUMED SOAPS; EAU DE PERFUME; ESSENTIAL OILS AS PERFUME FOR LAUNDRY PURPOSES; LIQUID PERFUMES; OILS FOR PERFUMES AND SCENTS; PERFUME OILS FOR THE MANUFACTURE OF COSMETIC PREPARATIONS; PERFUMED CREAMS; PERFUMED EXTRACTS FOR TISSUES AND PERFUMES; PERFUMED PASTE; PERFUMED POWDER; PERFUMED SOAPS; LIQUID SOAP (U.S. CLS. 1, 4, 6, 50, 51 AND 52).

ZACHARY BELLO, EXAMINING ATTORNEY

CLASS 3—(Continued).

SN 85-292,803. MCNABB NUTRACEUTICALS, LLC, CHICAGO, IL. FILED 4-12-2011.

The logo for SUNOLOGY features the word "SUNOLOGY" in a bold, sans-serif font. The letter "O" is replaced by a stylized sun icon consisting of concentric circles and a central dot.

THE MARK CONSISTS OF THE WORD "SUNOLOGY" WITH A DEPICTION OF THE SUN REPLACING THE FIRST "O" IN THE WORD.

FOR SUN BLOCK; SUN SCREEN (U.S. CLS. 1, 4, 6, 50, 51 AND 52).

FIRST USE 4-10-2011; IN COMMERCE 4-10-2011.

NANCY CLARKE, EXAMINING ATTORNEY

SN 85-292,857. SOGEVAL LABORATORIES, INC., COPPELL, TX. FILED 4-12-2011.

WHITE-AS-A-LILY

THE MARK CONSISTS OF STANDARD CHARACTERS WITHOUT CLAIM TO ANY PARTICULAR FONT, STYLE, SIZE, OR COLOR.

FOR SHAMPOO FOR ANIMALS (U.S. CLS. 1, 4, 6, 50, 51 AND 52).

LINDA POWELL, EXAMINING ATTORNEY

SN 85-292,972. THE MEN'S DEPT., LLC, MINNEAPOLIS, MN. FILED 4-12-2011.

MICROTECH

THE MARK CONSISTS OF STANDARD CHARACTERS WITHOUT CLAIM TO ANY PARTICULAR FONT, STYLE, SIZE, OR COLOR.

FOR HAIRSTYLING PREPARATIONS, NAMELY, HAIR CREAMS AND HAIRSTYLING CREAMS (U.S. CLS. 1, 4, 6, 50, 51 AND 52).

TINA MAI, EXAMINING ATTORNEY

CLASS 3—(Continued).

SN 85-293,002. THE MEN'S DEPT., LLC, MINNEAPOLIS, MN. FILED 4-12-2011.

MACROTECH

THE MARK CONSISTS OF STANDARD CHARACTERS WITHOUT CLAIM TO ANY PARTICULAR FONT, STYLE, SIZE, OR COLOR.

FOR HAIRSTYLING PREPARATIONS, NAMELY, HAIR CREAMS AND HAIRSTYLING CREAMS (U.S. CLS. 1, 4, 6, 50, 51 AND 52).

TINA MAI, EXAMINING ATTORNEY

CLASS 3—(Continued).

SN 85-293,796. SPARTAN BRANDS, INC., NEW YORK, NY. FILED 4-13-2011.

STRIPLESS

THE MARK CONSISTS OF STANDARD CHARACTERS WITHOUT CLAIM TO ANY PARTICULAR FONT, STYLE, SIZE, OR COLOR.

FOR HAIR RELAXERS (U.S. CLS. 1, 4, 6, 50, 51 AND 52).

MARK SPARACINO, EXAMINING ATTORNEY

SN 85-293,226. REYNA, KAREN ELIZABETH, CHICAGO, IL. FILED 4-12-2011.

Manipure

THE MARK CONSISTS OF STANDARD CHARACTERS WITHOUT CLAIM TO ANY PARTICULAR FONT, STYLE, SIZE, OR COLOR.

FOR NAIL CARE KITS COMPRISING NAIL POLISH; NAIL ENAMEL REMOVERS; NAIL GROOMING PRODUCTS, NAMELY, TIPS, GLUE, LACQUER AND GLITTER; NAIL POLISH; NAIL POLISH BASE COAT; NAIL POLISH REMOVER; NAIL POLISH REMOVERS; NAIL POLISH TOP COAT; NAIL STENCILS; NAIL TIPS; NAIL VARNISH FOR COSMETIC PURPOSES; NAIL-POLISH REMOVERS (U.S. CLS. 1, 4, 6, 50, 51 AND 52).

LIEF MARTIN, EXAMINING ATTORNEY

SN 85-293,838. CENTRIC GROUP, L.L.C., ST. LOUIS, MO. FILED 4-13-2011.

BLACK ICE

THE MARK CONSISTS OF STANDARD CHARACTERS WITHOUT CLAIM TO ANY PARTICULAR FONT, STYLE, SIZE, OR COLOR.

FOR DEODORANTS AND ANTIPERSPIRANTS; SOAPS FOR PERSONAL USE; BODY LOTIONS; SKIN MOISTURIZERS; BODY WASH FOR HUMANS; HAIR GELS, SHAMPOOS, AND CONDITIONERS; AFTER-SHAVES, COLOGNES AND PERFUMES; NON-MEDICATED OINTMENTS FOR NON-MEDICAL USE (U.S. CLS. 1, 4, 6, 50, 51 AND 52).

BRIAN CALLAGHAN, EXAMINING ATTORNEY

SN 85-293,405. TCCD INTERNATIONAL, INC., POMPANO BEACH, FL. FILED 4-12-2011.

GEODEO

THE MARK CONSISTS OF STANDARD CHARACTERS WITHOUT CLAIM TO ANY PARTICULAR FONT, STYLE, SIZE, OR COLOR.

FOR DEODORANT FOR PERSONAL USE; DEODORANTS FOR BODY CARE; PERSONAL DEODORANTS (U.S. CLS. 1, 4, 6, 50, 51 AND 52).

PATRICIA EVANKO, EXAMINING ATTORNEY

SN 85-293,909. MEDIMETRIKS PHARMACEUTICALS, INC., FAIRFIELD, NJ. FILED 4-13-2011.

ARAMIDE

THE MARK CONSISTS OF STANDARD CHARACTERS WITHOUT CLAIM TO ANY PARTICULAR FONT, STYLE, SIZE, OR COLOR.

FOR SKIN MOISTURIZER (U.S. CLS. 1, 4, 6, 50, 51 AND 52).

THEODORE MCBRIDE, EXAMINING ATTORNEY

CLASS 3—(Continued).

SN 85-293,936. CONCEPT/COPY LLC, DEEPHAVEN, MN. FILED 4-13-2011.

MAKANA

THE MARK CONSISTS OF STANDARD CHARACTERS WITHOUT CLAIM TO ANY PARTICULAR FONT, STYLE, SIZE, OR COLOR.

THE ENGLISH TRANSLATION OF "MAKANA" IN THE MARK IS "GIFT".

FOR BEAUTY CREAMS FOR BODY CARE; FACE AND BODY LOTIONS; MOISTURIZING PREPARATIONS FOR THE SKIN; SHOWER GEL (U.S. CLS. 1, 4, 6, 50, 51 AND 52).

THEODORE MCBRIDE, EXAMINING ATTORNEY

SN 85-294,217. ALBANI CORPORATION, MIAMI, FL. FILED 4-13-2011.



THE MARK CONSISTS OF A SPIRAL. FOR PERFUMES AND COLOGNES (U.S. CLS. 1, 4, 6, 50, 51 AND 52).

FIRST USE 4-17-2007; IN COMMERCE 4-17-2007.
GIANCARLO CASTRO, EXAMINING ATTORNEY

SN 85-294,377. PASTELS INTERNATIONAL, INC., MARINA DEL REY, CA. FILED 4-13-2011.

ALOE BARE

THE MARK CONSISTS OF STANDARD CHARACTERS WITHOUT CLAIM TO ANY PARTICULAR FONT, STYLE, SIZE, OR COLOR.

FOR DEPILATORIES (U.S. CLS. 1, 4, 6, 50, 51 AND 52).
FIRST USE 1-26-1995; IN COMMERCE 1-27-1995.
JULIE GUTTADAURO, EXAMINING ATTORNEY

CLASS 3—(Continued).

SN 85-294,821. BACON PRODUCTS CORPORATION, CHATTANOOGA, TN. FILED 4-14-2011.

MY BUDDY ORGANIC SHAMPOO

THE MARK CONSISTS OF STANDARD CHARACTERS WITHOUT CLAIM TO ANY PARTICULAR FONT, STYLE, SIZE, OR COLOR.

OWNER OF U.S. REG. NOS. 1,533,112, 2,955,242 AND OTHERS.

NO CLAIM IS MADE TO THE EXCLUSIVE RIGHT TO USE "ORGANIC SHAMPOO", APART FROM THE MARK AS SHOWN.

FOR PET CARE PRODUCTS, NAMELY, NON-MEDICATED ORGANIC SHAMPOO FOR PETS (U.S. CLS. 1, 4, 6, 50, 51 AND 52).

FIRST USE 2-10-2010; IN COMMERCE 2-10-2010.
PAM WILLIS, EXAMINING ATTORNEY

SN 85-294,825. KIMBERLY-CLARK WORLDWIDE, INC., NEENAH, WI. FILED 4-14-2011.

ONE & DONE

THE MARK CONSISTS OF STANDARD CHARACTERS WITHOUT CLAIM TO ANY PARTICULAR FONT, STYLE, SIZE, OR COLOR.

FOR DISPOSABLE BABY WIPES (U.S. CLS. 1, 4, 6, 50, 51 AND 52).

JOHN HWANG, EXAMINING ATTORNEY

SN 85-296,718. LI, COLLEEN, SAN FRANCISCO, CA. FILED 4-15-2011.

Dandi

THE MARK CONSISTS OF STANDARD CHARACTERS WITHOUT CLAIM TO ANY PARTICULAR FONT, STYLE, SIZE, OR COLOR.

FOR COSMETIC PREPARATIONS; NAIL POLISH; NAIL POLISH BASE COAT; NAIL POLISH REMOVER; NAIL POLISH TOP COAT (U.S. CLS. 1, 4, 6, 50, 51 AND 52).

JOHN GARTNER, EXAMINING ATTORNEY

CLASS 3—(Continued).

SN 85-296,811. MELALEUCA, INC., IDAHO FALLS, ID.
FILED 4-15-2011.

AFFINIA

THE MARK CONSISTS OF STANDARD CHARACTERS WITHOUT CLAIM TO ANY PARTICULAR FONT, STYLE, SIZE, OR COLOR.

FOR HAIR CONDITIONER; HAIR SHAMPOO; HAIR STYLING GEL; HAIR STYLING PREPARATIONS; HAIR STYLING SPRAY (U.S. CLS. 1, 4, 6, 50, 51 AND 52).
SUSAN LESLIE DUBOIS, EXAMINING ATTORNEY

SN 85-296,822. MELALEUCA, INC., IDAHO FALLS, ID.
FILED 4-15-2011.

AFFINITY

THE MARK CONSISTS OF STANDARD CHARACTERS WITHOUT CLAIM TO ANY PARTICULAR FONT, STYLE, SIZE, OR COLOR.

FOR HAIR CONDITIONER; HAIR SHAMPOO; HAIR STYLING GEL; HAIR STYLING PREPARATIONS; HAIR STYLING SPRAY (U.S. CLS. 1, 4, 6, 50, 51 AND 52).
SUSAN LESLIE DUBOIS, EXAMINING ATTORNEY

SN 85-296,878. JOSIE MARAN COSMETICS, LLC, LOS ANGELES, CA. FILED 4-15-2011.

LUXURY WITH A CONSCIENCE

THE MARK CONSISTS OF STANDARD CHARACTERS WITHOUT CLAIM TO ANY PARTICULAR FONT, STYLE, SIZE, OR COLOR.

FOR (BASED ON USE IN COMMERCE) BODY LOTIONS; COSMETIC PREPARATIONS FOR SKIN CARE; COSMETICS; HAIR CARE PREPARATIONS; HAIR CONDITIONER; HAND LOTIONS; MAKE-UP REMOVER; NON-MEDICATED LIP CARE PREPARATIONS; PRE-MOISTENED COSMETIC WIPES; SHAMPOOS; TANNING CREAMS(BASED ON INTENT TO USE) FRAGRANCES; PERFUME (U.S. CLS. 1, 4, 6, 50, 51 AND 52).
FIRST USE 9-1-2007; IN COMMERCE 9-1-2007.
RENEE MCCRAY, EXAMINING ATTORNEY

CLASS 3—(Continued).

SN 85-298,613. KELLWOOD COMPANY, CHESTERFIELD, MO. FILED 4-19-2011.

BLK DNM

THE MARK CONSISTS OF THE LETTERS "BLK DNM" IN A STYLIZED FONT.

FOR BATH BEADS; BATH CREAM; BATH CRYSTALS; BATH FIZZIES; BATH FLAKES; BATH FOAM; BATH GEL; BATH LOTION; BATH MILKS; BATH OIL; BATH PEARLS; BATH POWDER; BATH SALTS; BATH SOAPS; BODY SPRAYS; BUBBLE BATH; COLOGNE; EAU DE PERFUME; EAU DE TOILETTE AND EAU DE COLOGNE; FRAGRANCES; HAIR CARE PREPARATIONS; HAIR CONDITIONERS; HAIR DRESSINGS FOR MEN; HAIR DRESSINGS FOR WOMEN; HAIR DYE; HAIR GEL AND HAIR MOUSSE; HAIR LOTION; HAIR OILS; HAIR SHAMPOO; HAIR SPRAY; HAIR STYLING GEL; LOTIONS FOR FACE AND BODY CARE; MAKE UP REMOVING PREPARATIONS; MAKE-UP; MAKE-UP REMOVER; NAIL GROOMING PRODUCTS, NAMELY, TIPS, GLUE, LACQUER AND GLITTER; NAIL POLISH; PERFUMES; SKIN CREAM (U.S. CLS. 1, 4, 6, 50, 51 AND 52).

EUGENIA MARTIN, EXAMINING ATTORNEY

SN 85-301,043. DISNEY ENTERPRISES, INC., BURBANK, CA. FILED 4-21-2011.

LANIWAI

THE MARK CONSISTS OF STANDARD CHARACTERS WITHOUT CLAIM TO ANY PARTICULAR FONT, STYLE, SIZE, OR COLOR.

FOR COSMETICS; DENTIFRICES; NON-MEDICATED TOILETRIES; FRAGRANCES; PERFUMES (U.S. CLS. 1, 4, 6, 50, 51 AND 52).
NAAKWAMA ANKRAH, EXAMINING ATTORNEY

SN 85-305,862. UNITE EUROTHERAPY, INC., CARLSBAD, CA. FILED 4-27-2011.

GO365

THE MARK CONSISTS OF STANDARD CHARACTERS WITHOUT CLAIM TO ANY PARTICULAR FONT, STYLE, SIZE, OR COLOR.

FOR HAIR CARE PRODUCTS, NAMELY SHAMPOOS AND SPRAYS (U.S. CLS. 1, 4, 6, 50, 51 AND 52).
FIRST USE 5-1-2002; IN COMMERCE 5-1-2002.
APRIL ROACH, EXAMINING ATTORNEY

CLASS 3—(Continued).

SN 85-306,973. L'OREAL, PARIS, FRANCE, FILED 4-28-2011.

TELESCOPIC CYBER

THE MARK CONSISTS OF STANDARD CHARACTERS WITHOUT CLAIM TO ANY PARTICULAR FONT, STYLE, SIZE, OR COLOR.

FOR MASCARA (U.S. CLS. 1, 4, 6, 50, 51 AND 52).
BARBARA A. GOLD, EXAMINING ATTORNEY

CLASS 3—(Continued).

SN 85-308,949. PHYSICIANS FORMULA, INC., AZUSA, CA. FILED 4-29-2011.

SEASON 2 SEASON

THE MARK CONSISTS OF STANDARD CHARACTERS WITHOUT CLAIM TO ANY PARTICULAR FONT, STYLE, SIZE, OR COLOR.

FOR COSMETICS (U.S. CLS. 1, 4, 6, 50, 51 AND 52).
JAY BESCH, EXAMINING ATTORNEY

SN 85-307,083. PURE & NATURAL COMPANY, SCOTTSDALE, AZ. FILED 4-28-2011.

PUREX SUPERPACKS

THE MARK CONSISTS OF STANDARD CHARACTERS WITHOUT CLAIM TO ANY PARTICULAR FONT, STYLE, SIZE, OR COLOR.

OWNER OF U.S. REG. NOS. 1,062,573, 3,094,059 AND OTHERS.

FOR FABRIC SOFTENERS; LAUNDRY BLEACH; LAUNDRY DETERGENTS; STAIN REMOVERS (U.S. CLS. 1, 4, 6, 50, 51 AND 52).

JAY BESCH, EXAMINING ATTORNEY

SN 85-309,524. TUPPERWARE PRODUCTS S.A., FRIBOURG, SWITZERLAND, FILED 5-2-2011.

ROCKIN GIRL

THE MARK CONSISTS OF STANDARD CHARACTERS WITHOUT CLAIM TO ANY PARTICULAR FONT, STYLE, SIZE, OR COLOR.

NO CLAIM IS MADE TO THE EXCLUSIVE RIGHT TO USE "GIRL", APART FROM THE MARK AS SHOWN.

FOR PERFUMERY; DEODORANT AND ANTIPERSPIRANTS FOR PERSONAL USE; TALCUM POWDER; AND NON-MEDICATED SKIN CARE PREPARATIONS (U.S. CLS. 1, 4, 6, 50, 51 AND 52).

NELSON SNYDER, EXAMINING ATTORNEY

SN 85-307,650. IMPERIAL DAX COMPANY, INC., FAIRFIELD, NJ. FILED 4-28-2011.

Dax 54, LLC

THE MARK CONSISTS OF STANDARD CHARACTERS WITHOUT CLAIM TO ANY PARTICULAR FONT, STYLE, SIZE, OR COLOR.

NO CLAIM IS MADE TO THE EXCLUSIVE RIGHT TO USE "LLC", APART FROM THE MARK AS SHOWN.

FOR COSMETICS; NON-MEDICATED SKIN CARE PREPARATIONS; NON-MEDICATED SKIN CONDITIONING PREPARATIONS; HAIR CARE PREPARATIONS; HAIR GELS; HAIR CREAM; SHAMPOOS; BRILLIANTINE; HAIR RELAXERS; HAIR CARE PRODUCTS, NAMELY, PRODUCTS FOR IMPROVING HAIR TEXTURE AND MOISTURE; HAIR SPRAYS; HAIR LOTIONS; BRAID HAIR SPRAY; SHEEN HAIR SPRAY; FINISHING GLOSS HAIR SPRAY (U.S. CLS. 1, 4, 6, 50, 51 AND 52).

CORY BOONE, EXAMINING ATTORNEY

SN 85-310,915. THE PROCTER & GAMBLE COMPANY, CINCINNATI, OH. FILED 5-3-2011.



THE COLOR(S) BLUE AND WHITE IS/ARE CLAIMED AS A FEATURE OF THE MARK.

THE MARK CONSISTS OF THE WORD SECRET IN WHITE SCRIPT ON A FLOWER DESIGN WITH FOUR PETALS IN SHADES OF LIGHT TO DARK BLUE.

FOR ANTIPERSPIRANTS AND DEODORANTS FOR PERSONAL USE; BODY SPRAYS (U.S. CLS. 1, 4, 6, 50, 51 AND 52).

ARETHA SOMERVILLE, EXAMINING ATTORNEY

CLASS 3—(Continued).

SN 85-312,271. U.S. NONWOVENS CORPORATION, BRENTWOOD, NY. FILED 5-4-2011.

REDI SOFT

THE MARK CONSISTS OF STANDARD CHARACTERS WITHOUT CLAIM TO ANY PARTICULAR FONT, STYLE, SIZE, OR COLOR.

FOR FABRIC SOFTENER, FABRIC SOFTENER SHEETS AND LIQUID FABRIC SOFTENER (U.S. CLS. 1, 4, 6, 50, 51 AND 52).

BRIAN PINO, EXAMINING ATTORNEY

SN 85-314,332. PURE & NATURAL COMPANY, SCOTTSDALE, AZ. FILED 5-6-2011.

ULTRAPACKS

THE MARK CONSISTS OF STANDARD CHARACTERS WITHOUT CLAIM TO ANY PARTICULAR FONT, STYLE, SIZE, OR COLOR.

FOR FABRIC SOFTENERS; LAUNDRY BLEACH; LAUNDRY DETERGENTS; STAIN REMOVERS (U.S. CLS. 1, 4, 6, 50, 51 AND 52).

JAY BESCH, EXAMINING ATTORNEY

SN 85-314,533. PRL USA HOLDINGS, INC., WILMINGTON, DE. FILED 5-6-2011.

ULTIMATE RALPH LAUREN

THE MARK CONSISTS OF STANDARD CHARACTERS WITHOUT CLAIM TO ANY PARTICULAR FONT, STYLE, SIZE, OR COLOR.

OWNER OF U.S. REG. NOS. 1,222,278, 3,170,046 AND OTHERS.

THE NAME(S), PORTRAIT(S), AND/OR SIGNATURE(S) SHOWN IN THE MARK IDENTIFIES "RALPH LAUREN", WHOSE CONSENT(S) TO REGISTER IS MADE OF RECORD.

FOR PERFUME, EAU DE TOILETTE, SCENTED BODY LOTION AND SHOWER GEL (U.S. CLS. 1, 4, 6, 50, 51 AND 52).

PRISCILLA MILTON, EXAMINING ATTORNEY

CLASS 3—(Continued).

SN 85-316,548. LG HOUSEHOLD & HEALTH CARE LTD., SEOUL, REPUBLIC OF KOREA, FILED 5-10-2011.

su:m₃₇°

OWNER OF REPUBLIC OF KOREA REG. NO. 0751990, DATED 7-1-2008, EXPIRES 7-1-2018.

THE MARK CONSISTS OF THE STYLIZED TERM "SU" IN LOWER CASE WITH THE STYLIZED PUNCTUATION MARK ":" AND THE STYLIZED LETTER "M" IN LOWER CASE WITH THE STYLIZED NUMERALS "37" AND A DEGREE SIGN ALL IN ONE LINE.

FOR COSMETICS; SKIN MILK LOTIONS; PERFUMES; CLEANSING CREAMS; SHAMPOOS; HAIR RINSES; HAIR ESSENCE IN THE NATURE OF PERFUMED OILS FOR HAIR; SUNSCREEN LOTIONS; NAIL POLISH; NAIL DECOLORANTS; MASK PACK FOR COSMETIC PURPOSES; COSMETIC SOAPS; MASSAGE CREAM; BODY LOTIONS; AROMATICS NOT FOR MEDICAL PURPOSES, NAMELY, AROMATIC OILS, AROMATIC CREAMS AND AROMATIC POTPOURRIS; BATH GELS; SHOWER GELS; MASSAGE OIL; COSMETIC NOURISHING CREAMS; ENAMEL FOR MANICURE; VARNISH-REMOVING PREPARATIONS; COSMETIC BATH POWDER; PERFUMED POWDER; HAIR LOTIONS; BODY CREAMS; SKIN CLEANSING FOAMS; SKIN CLEANSING LOTIONS; BODY CLEANSER (U.S. CLS. 1, 4, 6, 50, 51 AND 52).

REBECCA POVARCHUK, EXAMINING ATTORNEY

SN 85-318,121. A.V.W. INC, DBA MAX PROFESSIONAL, FT LAUDERDALE, FL. FILED 5-11-2011.

OFF

THE MARK CONSISTS OF STANDARD CHARACTERS WITHOUT CLAIM TO ANY PARTICULAR FONT, STYLE, SIZE, OR COLOR.

FOR ALL-PURPOSE CLEANERS (U.S. CLS. 1, 4, 6, 50, 51 AND 52).

FIRST USE 5-16-2004; IN COMMERCE 1-8-2006.

REGINA DRUMMOND, EXAMINING ATTORNEY

CLASS 3—(Continued).

SN 85-323,596. DJF ENTERPRISES, NEW YORK, NY. FILED 5-18-2011.

SMASHBOX PHOTO ANGLE

THE MARK CONSISTS OF STANDARD CHARACTERS WITHOUT CLAIM TO ANY PARTICULAR FONT, STYLE, SIZE, OR COLOR.
FOR COSMETICS; NON-MEDICATED SKIN CARE PREPARATIONS (U.S. CLS. 1, 4, 6, 50, 51 AND 52).
SOPHIA S. KIM, EXAMINING ATTORNEY



SN 85-323,736. SPARTAN BRANDS, INC., NEW YORK, NY. FILED 5-18-2011.

NEUTRCOCO

THE MARK CONSISTS OF STANDARD CHARACTERS WITHOUT CLAIM TO ANY PARTICULAR FONT, STYLE, SIZE, OR COLOR.
FOR HAIR CONDITIONERS; MOISTURIZING SKIN LOTIONS (U.S. CLS. 1, 4, 6, 50, 51 AND 52).
MARK SPARACINO, EXAMINING ATTORNEY



SN 85-325,323. SPARTAN BRANDS, INC., NEW YORK, NY. FILED 5-19-2011.

WAVE MAGIC

THE MARK CONSISTS OF STANDARD CHARACTERS WITHOUT CLAIM TO ANY PARTICULAR FONT, STYLE, SIZE, OR COLOR.
FOR HAIR CONDITIONERS (U.S. CLS. 1, 4, 6, 50, 51 AND 52).
MARK SPARACINO, EXAMINING ATTORNEY

CLASS 3—(Continued).

SN 85-325,343. SPARTAN BRANDS, INC., NEW YORK, NY. FILED 5-19-2011.

IRON RIGHT

THE MARK CONSISTS OF STANDARD CHARACTERS WITHOUT CLAIM TO ANY PARTICULAR FONT, STYLE, SIZE, OR COLOR.
FOR HAIR PRESSING CREAM (U.S. CLS. 1, 4, 6, 50, 51 AND 52).
MARK SPARACINO, EXAMINING ATTORNEY



SN 85-334,613. GIOVANNI COSMETICS, INC., RANCHO DOMINGUEZ, CA. FILED 5-31-2011.

2chic

THE MARK CONSISTS OF STANDARD CHARACTERS WITHOUT CLAIM TO ANY PARTICULAR FONT, STYLE, SIZE, OR COLOR.

FOR HAIR CARE PRODUCTS, NAMELY, HAIR CARE LOTIONS, HAIR CARE CREAMS, HAIR OILS; HAIR CARE PREPARATIONS; SHAMPOOS, CONDITIONERS; NON-MEDICATED HAIR TREATMENT PREPARATIONS FOR COSMETIC PURPOSES; HAIR STYLING AIDS, NAMELY, NON-MEDICATED HAIR STYLING TREATMENT PREPARATIONS FOR COSMETIC PURPOSES, NON-MEDICATED LEAVE-IN HAIR TREATMENT PREPARATIONS FOR COSMETIC PURPOSES, HAIR STYLING SPRAYS, NON-MEDICATED HAIR STYLING TREATMENT PREPARATIONS FOR COSMETIC PURPOSES, LEAVE-IN CONDITIONERS, HAIR STYLING PREPARATIONS, HAIR WAXES; NON-MEDICATED HAIR FLAT IRONING SERUMS, NON-MEDICATED HAIR SERUMS, HAIR BLOW DRY SPRAYS, BODY WASH, BODY LOTIONS, BODY OIL, MASSAGE OIL (U.S. CLS. 1, 4, 6, 50, 51 AND 52).

ANDREA K. NADELMAN, EXAMINING ATTORNEY

CLASS 3—(Continued).

SN 85-334,614. GIOVANNI COSMETICS, INC., RANCHO DOMINGUEZ, CA. FILED 5-31-2011.

2chic or not 2chic

THE MARK CONSISTS OF STANDARD CHARACTERS WITHOUT CLAIM TO ANY PARTICULAR FONT, STYLE, SIZE, OR COLOR.

FOR HAIR CARE PRODUCTS, NAMELY, HAIR CARE LOTIONS, HAIR CARE CREAMS, HAIR OILS; HAIR CARE PREPARATIONS; SHAMPOOS, CONDITIONERS; NON-MEDICATED HAIR TREATMENT PREPARATIONS FOR COSMETIC PURPOSES; HAIR STYLING AIDS, NAMELY, NON-MEDICATED HAIR STYLING TREATMENT PREPARATIONS FOR COSMETIC PURPOSES, NON-MEDICATED LEAVE-IN HAIR TREATMENT PREPARATIONS FOR COSMETIC PURPOSES, HAIR STYLING SPRAYS, NON-MEDICATED HAIR STYLING TREATMENT PREPARATIONS FOR COSMETIC PURPOSES, LEAVE-IN CONDITIONERS, HAIR STYLING PREPARATIONS, HAIR WAXES; NON-MEDICATED HAIR FLAT IRONING SERUMS, NON-MEDICATED HAIR SERUMS, HAIR BLOW DRY SPRAYS, BODY WASH, BODY LOTIONS, BODY OIL, MASSAGE OIL (U.S. CLS. 1, 4, 6, 50, 51 AND 52).

ANDREA K. NADELMAN, EXAMINING ATTORNEY

CLASS 4—(Continued).

SN 85-121,292. ATLAS MARKETING, LLC, HAUSER, ID. FILED 9-1-2010.

COUNTRY PRIDE

THE MARK CONSISTS OF STANDARD CHARACTERS WITHOUT CLAIM TO ANY PARTICULAR FONT, STYLE, SIZE, OR COLOR.

FOR FUEL PELLETS (U.S. CLS. 1, 6 AND 15).
FIRST USE 8-30-2005; IN COMMERCE 8-30-2005.
GISELLE AGOSTO, EXAMINING ATTORNEY

SN 85-260,273. CAYTON, DAVID, DURHAM, NC. FILED 3-7-2011.

DIAMOND
CANDLES | A Ring in
Every Candle

CLASS 4—LUBRICANTS AND FUELS

SN 79-097,051. NABTESCO CORPORATION, JAPAN, FILED 4-12-2011.

VIGOOIL

THE MARK CONSISTS OF STANDARD CHARACTERS WITHOUT CLAIM TO ANY PARTICULAR FONT, STYLE, SIZE, OR COLOR.

OWNER OF INTERNATIONAL REGISTRATION 1076227 DATED 4-12-2011, EXPIRES 4-12-2021.

FOR INDUSTRIAL OIL (U.S. CLS. 1, 6 AND 15).
JOHN WILKE, EXAMINING ATTORNEY

NO CLAIM IS MADE TO THE EXCLUSIVE RIGHT TO USE "DIAMOND CANDLES" AND "A RING IN EVERY CANDLE", APART FROM THE MARK AS SHOWN.

THE MARK CONSISTS OF THE TEXT "DIAMOND CANDLES" WITH A DESIGN OF A DIAMOND OVER THE LETTER "O", A VERTICAL SEPARATOR LINE DOWN THE MIDDLE, AND TO THE RIGHT OF THE SEPARATOR, THE TEXT "A RING IN EVERY CANDLE".

FOR CANDLES CONTAINING DIAMONDS (U.S. CLS. 1, 6 AND 15).

FIRST USE 1-0-2011; IN COMMERCE 2-12-2011.
CARYN GLASSER, EXAMINING ATTORNEY

SN 85-291,472. PACIFIC COAST FIBER FUELS, LLC, SPOKANE, WA. FILED 4-11-2011.

OLYMPUS

SN 85-054,497. DONTCHEVA, SILVIA, NEW YORK, NY. FILED 6-4-2010.

KENDUL

THE MARK CONSISTS OF STANDARD CHARACTERS WITHOUT CLAIM TO ANY PARTICULAR FONT, STYLE, SIZE, OR COLOR.

FOR CANDLES (U.S. CLS. 1, 6 AND 15).
CORY BOONE, EXAMINING ATTORNEY

THE MARK CONSISTS OF STANDARD CHARACTERS WITHOUT CLAIM TO ANY PARTICULAR FONT, STYLE, SIZE, OR COLOR.

FOR WOOD PELLETS FOR USE AS FUEL IN WOOD STOVES (U.S. CLS. 1, 6 AND 15).

JUDITH HELFMAN, EXAMINING ATTORNEY

CLASS 4—(Continued).

SN 85-292,499. WAX BOX FIRELOG CORP, OROVILLE, CA.
FILED 4-12-2011.



OWNER OF U.S. REG. NO. 3,875,970.
NO CLAIM IS MADE TO THE EXCLUSIVE RIGHT TO
USE "CAMPFIRE LOG" AND "CLEAN FLAME", APART
FROM THE MARK AS SHOWN.

THE COLOR(S) YELLOW, ORANGE, GREEN, BLACK IS/
ARE CLAIMED AS A FEATURE OF THE MARK.

THE MARK CONSISTS OF "CAMPFIRE LOG" IN YEL-
LOW AND ORANGE STYLIZED LETTERS WITH BLACK
SHADING AND A YELLOW, ORANGE, AND BLACK
FLAME APPEARING ABOVE THE LETTER "I"; NEXT TO
"LOG" IS "BY" IN BLACK STYLIZED LETTERS; TO THE
RIGHT OF "BY" IS "CLEAN FLAME" IN GREEN STYLIZED
LETTERS WITH BLACK SHADING; BETWEEN "CLEAN"
AND "FLAME" IS AN ORANGE AND YELLOW FLAME.

FOR ARTIFICIAL FIREPLACE LOGS; SOLID FIRE
STARTERS (U.S. CLS. 1, 6 AND 15).

FIRST USE 3-0-2011; IN COMMERCE 3-0-2011.

SETH A. RAPPAPORT, EXAMINING ATTORNEY

SN 85-341,041. PACIFIC COAST FIBER FUELS, LLC, SPO-
KANE, WA. FILED 6-8-2011.

CASCADE

THE MARK CONSISTS OF STANDARD CHARACTERS
WITHOUT CLAIM TO ANY PARTICULAR FONT, STYLE,
SIZE, OR COLOR.

FOR WOOD PELLETS FOR USE AS FUEL IN WOOD
STOVES (U.S. CLS. 1, 6 AND 15).

JUDITH HELFMAN, EXAMINING ATTORNEY

CLASS 5—(Continued).

SN 76-706,163. NGUYEN, TUONG, WESTMINSTER, CA.
FILED 1-28-2011.



NO CLAIM IS MADE TO THE EXCLUSIVE RIGHT TO
USE "AMERICA", APART FROM THE MARK AS SHOWN.

THE COLOR(S) RED, WHITE AND BLUE IS/ARE
CLAIMED AS A FEATURE OF THE MARK.

THE MARK CONSISTS OF THE WORDING "AMERICA
LONGEVITY" WITH "AMERICA" IN RED, AND "LONG-
EVITY" IN BLUE, BOTH BENEATH A BLUE OUTLINED
RECTANGLE COMPRISING A BLUE LEFT SIDE WITH
FOUR WHOLE WHITE STARS AND ADDITIONAL PARTS
OF STARS THEREIN, AND RED AND WHITE WAVY
STRIPES ON THE RIGHT SIDE, TOGETHER SIMULATING
AN AMERICAN FLAG.

FOR NUTRITIONAL AND DIETARY SUPPLEMENTS
(U.S. CLS. 6, 18, 44, 46, 51 AND 52).

FIRST USE 1-20-2011; IN COMMERCE 1-20-2011.

LAURA KOVALSKY, EXAMINING ATTORNEY

SN 76-707,208. GENX INTERNATIONAL, INC., GUILFORD,
CT. FILED 4-11-2011.

GLOBAL TOTAL

CLASS 5—PHARMACEUTICALS

SN 76-702,131. NGUYEN, TUONG, WESTMINSTER, CA.
FILED 3-18-2010.

COLONVITA

THE MARK CONSISTS OF STANDARD CHARACTERS
WITHOUT CLAIM TO ANY PARTICULAR FONT, STYLE,
SIZE, OR COLOR.

FOR DIETARY AND NUTRITIONAL SUPPLEMENTS
(U.S. CLS. 6, 18, 44, 46, 51 AND 52).

FIRST USE 10-1-2008; IN COMMERCE 10-1-2008.

KEVIN CORWIN, EXAMINING ATTORNEY

THE MARK CONSISTS OF STANDARD CHARACTERS
WITHOUT CLAIM TO ANY PARTICULAR FONT, STYLE,
SIZE, OR COLOR.

FOR CHEMICALS FOR USE IN MEDICAL SCIENCE,
NAMELY, FERTILITY ENHANCEMENT PREPARA-
TIONS FOR USE IN CULTURING AND EXTENDED
CULTURING OF EMBRYOS (U.S. CLS. 6, 18, 44, 46, 51
AND 52).

FIRST USE 1-0-2011; IN COMMERCE 1-0-2011.

TOBY BULLOFF, EXAMINING ATTORNEY

CLASS 5—(Continued).

SN 77-121,059. FIDIA FARMACEUTICI S.P.A., I-35031 ABA-NO TERME, ITALY, FILED 3-2-2007.

HYALOFEMME

THE MARK CONSISTS OF STANDARD CHARACTERS WITHOUT CLAIM TO ANY PARTICULAR FONT, STYLE, SIZE, OR COLOR.

OWNER OF ITALY REG. NO. 0000820850, DATED 7-24-2000, RENEWED AS REG. NO. 0001406197, DATED 1-18-2011, EXPIRES 3-26-2020.

THE WORD "HYALOFEMME" HAS NO MEANING IN A FOREIGN LANGUAGE.

FOR PHARMACEUTICAL PREPARATIONS FOR DERMATOLOGICAL AND GYNECOLOGICAL USE; PARAPHARMACEUTICAL PRODUCTS FOR USE IN DERMATOLOGY AND GYNECOLOGY; EXTERNAL ITCH CREAMS, GELS AND SPRAYS; LUBRICANTS FOR CONDOMS; VAGINAL MOISTURIZERS (U.S. CLS. 6, 18, 44, 46, 51 AND 52).

SUNG IN, EXAMINING ATTORNEY

SN 77-323,919. NITRIQUEST PHARMACEUTICALS, LLC, SCOTTSDALE, AZ. FILED 11-7-2007.

NITRIQUEST

THE MARK CONSISTS OF STANDARD CHARACTERS WITHOUT CLAIM TO ANY PARTICULAR FONT, STYLE, SIZE, OR COLOR.

FOR PHARMACEUTICALS AND PHARMACEUTICAL PREPARATIONS FOR USE IN CARDIOLOGY, HEMATOLOGY, NEUROLOGY, AND UROLOGY (U.S. CLS. 6, 18, 44, 46, 51 AND 52).

TOBY BULLOFF, EXAMINING ATTORNEY

SN 77-431,401. DYNAMIC BRIDGE, SOUTH EL MONTE, CA. AND KWAN, STEPHEN, SOUTH EL MONTE, CA. FILED 3-25-2008.

ENDURMAX

THE MARK CONSISTS OF STANDARD CHARACTERS WITHOUT CLAIM TO ANY PARTICULAR FONT, STYLE, SIZE, OR COLOR.

FOR HERBAL SUPPLEMENTS (U.S. CLS. 6, 18, 44, 46, 51 AND 52).

FIRST USE 8-12-2005; IN COMMERCE 8-12-2005.

ALEX KEAM, EXAMINING ATTORNEY

CLASS 5—(Continued).

SN 77-530,352. SOGEVAL, 53000 LAVAL, FRANCE, FILED 7-24-2008.

XEDEN

THE MARK CONSISTS OF STANDARD CHARACTERS WITHOUT CLAIM TO ANY PARTICULAR FONT, STYLE, SIZE, OR COLOR.

PRIORITY CLAIMED UNDER SEC. 44(D) ON FRANCE APPLICATION NO. 083551309, FILED 1-24-2008, REG. NO. 083551309, DATED 11-14-2008, EXPIRES 1-24-2018.

THE WORDING "XEDEN" HAS NO MEANING IN A FOREIGN LANGUAGE.

FOR VETERINARY PREPARATIONS, NAMELY, ANTIBIOTICS FOR CATS AND DOGS (U.S. CLS. 6, 18, 44, 46, 51 AND 52).

KIM MONINGHOFF, EXAMINING ATTORNEY

SN 77-558,043. AFEXA LIFE SCIENCES INC., EDMONTON, CANADA, FILED 8-28-2008.

AFEXA

THE MARK CONSISTS OF STANDARD CHARACTERS WITHOUT CLAIM TO ANY PARTICULAR FONT, STYLE, SIZE, OR COLOR.

PRIORITY CLAIMED UNDER SEC. 44(D) ON CANADA APPLICATION NO. 1408120, FILED 8-21-2008, REG. NO. TMA795093, DATED 4-8-2011, EXPIRES 4-8-2026.

FOR ALL NATURAL HEALTH FOOD SUPPLEMENTS, NAMELY, HEALTH FOOD SUPPLEMENTS FROM HERBAL, ANIMAL AND FISH SOURCES WHICH ARE IN THE FORM OF GROUND OR DRY PRODUCT, IN SOLUTION OR AS AN EXTRACT OF HERBAL, ANIMAL OR FISH SOURCES (U.S. CLS. 6, 18, 44, 46, 51 AND 52).

GISELLE AGOSTO, EXAMINING ATTORNEY

SN 77-564,873. NUTRITION RESOURCE, INC., DBA NUTRIBIOTIC, LAKEPORT, CA. FILED 9-8-2008.

NUTRIBIOTIC

THE MARK CONSISTS OF STANDARD CHARACTERS WITHOUT CLAIM TO ANY PARTICULAR FONT, STYLE, SIZE, OR COLOR.

OWNER OF U.S. REG. NOS. 3,697,758 AND 3,697,759. FOR PROTEIN SUPPLEMENTS IN POWDERED FORM; NUTRITIONAL ENERGY BARS FOR USE AS A MEAL SUBSTITUTE COMPRISED OF FRUIT (U.S. CLS. 6, 18, 44, 46, 51 AND 52).

FIRST USE 7-26-1994; IN COMMERCE 7-26-1994.

AMY C. KEAN, EXAMINING ATTORNEY

CLASS 5—(Continued).

SN 77-564,887. NUTRITION RESOURCE, INC., DBA NUTRIBIOTIC, LAKEPORT, CA. FILED 9-8-2008.



OWNER OF U.S. REG. NOS. 3,697,758 AND 3,697,759.
THE MARK CONSISTS OF THE WORD "NUTRIBIOTIC" IN UPPER AND LOWER CASE LETTERS, WITH THE "N" AND "B" BEING THE ONLY UPPER CASE LETTERS. THE LETTER "O" DEPICTED AS A GLOBE OF THE EARTH. A SMALL LEAF IS COVERING THE LOWER LEFT EDGE OF THE GLOBE AND A LARGER LEAF COVERING THE LOWER RIGHT EDGE OF THE GLOBE.

FOR PROTEIN SUPPLEMENTS IN POWDERED FORM; NUTRITIONAL ENERGY BARS FOR USE AS A MEAL SUBSTITUTE COMPRISED OF FRUIT (U.S. CLS. 6, 18, 44, 46, 51 AND 52).

FIRST USE 2-4-2008; IN COMMERCE 8-14-2008.
AMY C. KEAN, EXAMINING ATTORNEY

SN 77-823,894. MCCARRELL ENTERPRISE, LLC, DBA DR. BEN RECOMMENDS, ORLANDO, FL. FILED 9-10-2009.

Dr. Ben Recommends

THE MARK CONSISTS OF STANDARD CHARACTERS WITHOUT CLAIM TO ANY PARTICULAR FONT, STYLE, SIZE, OR COLOR.

OWNER OF U.S. REG. NO. 3,971,232.
"DOCTOR BEN" DOES NOT IDENTIFY A LIVING INDIVIDUAL.

FOR VITAMIN AND MINERAL SUPPLEMENTS (U.S. CLS. 6, 18, 44, 46, 51 AND 52).
JOHN HWANG, EXAMINING ATTORNEY

SN 77-838,101. BOSTON BAY BEVERAGE LLC, ACCORD, MA. FILED 9-30-2009.

REV UP YOUR MIND

THE MARK CONSISTS OF STANDARD CHARACTERS WITHOUT CLAIM TO ANY PARTICULAR FONT, STYLE, SIZE, OR COLOR.

FOR VITAMIN FORTIFIED BEVERAGES (U.S. CLS. 6, 18, 44, 46, 51 AND 52).
CURTIS FRENCH, EXAMINING ATTORNEY

CLASS 5—(Continued).

SN 79-067,542. OYSTERSHELL N.V., BELGIUM, FILED 3-31-2009.

RF2

THE MARK CONSISTS OF STANDARD CHARACTERS WITHOUT CLAIM TO ANY PARTICULAR FONT, STYLE, SIZE, OR COLOR.

OWNER OF INTERNATIONAL REGISTRATION 0999554 DATED 3-31-2009, EXPIRES 3-31-2019.

FOR PHARMACEUTICAL PREPARATIONS FOR DENTAL PLAQUE CONTROL (U.S. CLS. 6, 18, 44, 46, 51 AND 52).

SARA BENJAMIN, EXAMINING ATTORNEY

SN 79-089,663. FRIESLAND BRANDS BV, NETHERLANDS, FILED 10-20-2010.

STEDYGRO

THE MARK CONSISTS OF STANDARD CHARACTERS WITHOUT CLAIM TO ANY PARTICULAR FONT, STYLE, SIZE, OR COLOR.

PRIORITY DATE OF 6-14-2010 IS CLAIMED.
OWNER OF INTERNATIONAL REGISTRATION 1057402 DATED 10-20-2010, EXPIRES 10-20-2020.

FOR FOOD SUPPLEMENTS FOR MEDICAL USE; MILK FERMENTS FOR PHARMACEUTICAL PURPOSES; DIETETIC SUBSTANCES AND FOODSTUFFS FOR MEDICAL USE, NAMELY, DIETETIC FOODS ADAPTED FOR MEDICAL USE (U.S. CLS. 6, 18, 44, 46, 51 AND 52).

BARBARA RUTLAND, EXAMINING ATTORNEY

SN 79-097,288. RESDEVCO LTD., ISRAEL, FILED 4-11-2011.

Conheal

THE MARK CONSISTS OF STANDARD CHARACTERS WITHOUT CLAIM TO ANY PARTICULAR FONT, STYLE, SIZE, OR COLOR.

OWNER OF INTERNATIONAL REGISTRATION 1076859 DATED 4-11-2011, EXPIRES 4-11-2021.

FOR EYE DROP, EYE-WASH, COLLYRIUM FOR TREATING HUMAN AND VETERINARY EYE PROBLEMS (U.S. CLS. 6, 18, 44, 46, 51 AND 52).

YAT SYE, LEE, EXAMINING ATTORNEY

CLASS 5—(Continued).

SN 85-001,730. BERRIES FOR LIFE, FORT WAYNE, IN. FILED 3-30-2010.

BERRYIMMUNE

THE MARK CONSISTS OF STANDARD CHARACTERS WITHOUT CLAIM TO ANY PARTICULAR FONT, STYLE, SIZE, OR COLOR.

FOR DIETARY SUPPLEMENTS (U.S. CLS. 6, 18, 44, 46, 51 AND 52).

FIRST USE 6-15-2009; IN COMMERCE 3-10-2010.
ELLEN PERKINS, EXAMINING ATTORNEY

SN 85-025,056. ASTRAZENECA AB, SODERTALJE, SWEDEN, FILED 4-28-2010.

BRILIQUE

THE MARK CONSISTS OF STANDARD CHARACTERS WITHOUT CLAIM TO ANY PARTICULAR FONT, STYLE, SIZE, OR COLOR.

OWNER OF ERPN CMNTY TM OFC REG. NO. 008719676, DATED 6-28-2010, EXPIRES 11-27-2019.

FOR PHARMACEUTICAL PREPARATIONS AND SUBSTANCES FOR THE PREVENTION AND/OR TREATMENT OF CARDIOVASCULAR DISEASES (U.S. CLS. 6, 18, 44, 46, 51 AND 52).

KARANENDRA S. CHHINA, EXAMINING ATTORNEY

SN 85-044,659. BRISTOL-MYERS SQUIBB COMPANY, NEW YORK, NY. FILED 5-21-2010.

GLEDEPA

THE MARK CONSISTS OF STANDARD CHARACTERS WITHOUT CLAIM TO ANY PARTICULAR FONT, STYLE, SIZE, OR COLOR.

FOR PHARMACEUTICAL PREPARATIONS FOR HUMAN USE FOR THE TREATMENT AND PREVENTION OF OBESITY, DIABETES, INCONTINENCE, CARDIOVASCULAR DISEASES, CENTRAL NERVOUS SYSTEM DISEASES AND DISORDERS, METABOLIC DISORDERS, STROKE, CANCER, INFLAMMATION AND INFLAMMATORY DISEASES, RESPIRATORY AND INFECTIOUS DISEASES, AUTO-IMMUNE DISEASES, SOLID ORGAN TRANSPLANT REJECTION; PHARMACEUTICAL PREPARATIONS FOR HUMAN USE, NAMELY, ANTIBIOTICS, ANTI-FUNGALS, ANTI-VIRALS, IMMUNOSUPPRESSANTS AND PHARMACEUTICAL ANTIBODIES (U.S. CLS. 6, 18, 44, 46, 51 AND 52).

MAUREEN DALL, EXAMINING ATTORNEY

CLASS 5—(Continued).

SN 85-090,818. ENVIRO TECH CHEMICAL SERVICES, INC., MODESTO, CA. FILED 7-22-2010.

HB2

THE MARK CONSISTS OF STANDARD CHARACTERS WITHOUT CLAIM TO ANY PARTICULAR FONT, STYLE, SIZE, OR COLOR.

FOR ANTIMICROBIAL CHEMICAL PREPARATIONS FOR USE ON FOOD AND IN WATER IN ORDER TO INHIBIT MICROBIAL CONTAMINATION DURING FOOD PROCESSING (U.S. CLS. 6, 18, 44, 46, 51 AND 52).

FIRST USE 2-15-2010; IN COMMERCE 2-15-2010.
MARTHA FROMM, EXAMINING ATTORNEY

SN 85-103,860. PURETERRA NATURALS, INC., OLDSMAR, FL. FILED 8-10-2010.

COGO

THE MARK CONSISTS OF STANDARD CHARACTERS WITHOUT CLAIM TO ANY PARTICULAR FONT, STYLE, SIZE, OR COLOR.

FOR FULL LINE OF PHARMACEUTICAL PREPARATIONS FOR HORSES, DOGS, CATS AND OTHER ANIMALS; CLINICAL PRODUCTS USED TO ADDRESS ARTHRITIS, ALLERGIES, HIP DYSPLASIA, IMMUNE FUNCTION, MUSCLE DEVELOPMENT, SKIN CARE AND THE GENERAL HEALTH AND WELL-BEING OF ANIMALS, NAMELY, MEDICATED ANIMAL FEED SUPPLEMENTS, AMINO ACIDS FOR VETERINARY USE, BANDAGES FOR WOUND CARE, BALMS FOR VETERINARY PURPOSES; VETERINARY CLINICAL PRODUCTS, NAMELY, MEDICATED ANTIMICROBIAL CLEANSING FLUSHES AND MEDICATED ANTIBACTERIAL HAND CLEANSERS; DENTAL RINSES FOR ANIMALS; DIETARY AND NUTRITIONAL SUPPLEMENTS FOR ANIMALS; VETERINARY SUPPLEMENTS, NAMELY, JOINT CARE FOR ANIMALS; FOOD SUPPLEMENTS AND TOPICAL PREPARATIONS FOR THE PREVENTION AND ELIMINATION OF TEAR STAINING OR EPIPHORA IN ANIMALS; PREPARATIONS FOR THE CLEANING AND TREATMENT OF EAR PROBLEMS AND DISORDERS FOR USE IN VETERINARY MEDICINE; MEDICATED EAR CLEANSING RINSES; EAR DROPS FOR ANIMALS; MEDICATED SKIN CARE AND WOUND CARE PREPARATIONS FOR ANIMALS; ALL-NATURAL TOPICAL PREPARATIONS FOR ANIMALS FOR THE TREATMENT OF SKIN IRRITATIONS, DERMATITIS, HOT SPOTS, INSECT BITES, SUMMER ITCH, SUNBURN, MUCKAGE, CUTS, FUNGUS, RAINROT AND FOR REPELLING INSECTS; MEDICATED LOTION FOR ANIMALS FOR THE TREATMENT OF SKIN IRRITATIONS, HOT SPOTS, INSECT BITES, SUMMER ITCH, SUNBURN, MUCKAGE, CUTS, FUNGUS, RAINROT AND FOR REPELLING INSECTS; MEDICATED SHAMPOOS FOR ANIMALS (U.S. CLS. 6, 18, 44, 46, 51 AND 52).

ELLEN BURNS, EXAMINING ATTORNEY

CLASS 5—(Continued).

SN 85-109,470. SPI PHARMA, INC., WILMINGTON, DE. FILED 8-17-2010.

ACTIMASK

THE MARK CONSISTS OF STANDARD CHARACTERS WITHOUT CLAIM TO ANY PARTICULAR FONT, STYLE, SIZE, OR COLOR.

FOR DRUG DELIVERY AGENTS IN THE FORM OF TABLETS, PILLS, AND POWDERS IN ORAL DOSAGE FORM THAT PROVIDE TASTE-MASKING OF ACTIVE INGREDIENTS AND FACILITATE THE DELIVERY OF A WIDE RANGE OF PHARMACEUTICALS AND NUTRITIONAL AND DIETARY SUPPLEMENTS (U.S. CLS. 6, 18, 44, 46, 51 AND 52).

DAVID ELTON, EXAMINING ATTORNEY

SN 85-114,120. IBITTA ENTERPRISES, INC., DBA NATURAL & HEALTHY PRODUCTS, SHERMAN OAKS, CA. FILED 8-23-2010.

Extrabiotic

THE MARK CONSISTS OF STANDARD CHARACTERS WITHOUT CLAIM TO ANY PARTICULAR FONT, STYLE, SIZE, OR COLOR.

FOR DIETARY AND NUTRITIONAL SUPPLEMENTS; DIETARY AND NUTRITIONAL SUPPLEMENTS CONTAINING INULIN (U.S. CLS. 6, 18, 44, 46, 51 AND 52).

FIRST USE 7-6-2010; IN COMMERCE 7-6-2010.

NAKIA HENRY, EXAMINING ATTORNEY

CLASS 5—(Continued).

SN 85-129,648. BRONDLUND, MARIANNE, HARLEV, DENMARK, FILED 9-14-2010.

IVI AL TSANNIS

THE MARK CONSISTS OF STANDARD CHARACTERS WITHOUT CLAIM TO ANY PARTICULAR FONT, STYLE, SIZE, OR COLOR.

PRIORITY CLAIMED UNDER SEC. 44(D) ON ERPNCMNTY TM OFC APPLICATION NO. 009272601, FILED 7-26-2010, REG. NO. 009272601, DATED 12-13-2010, EXPIRES 7-26-2020.

THE WORDING "IVI AL TSANNIS" HAS NO MEANING IN A FOREIGN LANGUAGE.

FOR PHARMACEUTICAL PREPARATIONS FOR THE TREATMENT OR FOR THE ASSISTING TREATMENT OF DIFFERENT TYPES OF CANCER, LYMPHOGENIC LEUKEMIA, LUPUS ERYTHEMATODES, AND DIABETES MELLITUS, FOR THE ASSISTING TREATMENT OF CORONARY HEART DISEASE, CORONARY INSUFFICIENCIES, AND LIPID METABOLIC DISORDERS, AND FOR THE TREATMENT OR THE ASSISTING TREATMENT OF DEGENERATIVE BONE DISEASES, RHEUMATOID ARTHRITIS, AND BONE METASTASES OF TUMORS; VETERINARY PREPARATIONS FOR THE TREATMENT OR FOR THE ASSISTING TREATMENT OF DIFFERENT TYPES OF CANCER, LYMPHOGENIC LEUKEMIA, LUPUS ERYTHEMATODES, AND DIABETES MELLITUS, FOR THE ASSISTING TREATMENT OF CORONARY HEART DISEASE, CORONARY INSUFFICIENCIES, AND LIPID METABOLIC DISORDERS, AND FOR THE TREATMENT OR THE ASSISTING TREATMENT OF DEGENERATIVE BONE DISEASES, RHEUMATOID ARTHRITIS, AND BONE METASTASES OF TUMORS; SANITARY PREPARATIONS FOR THE TREATMENT OR FOR THE ASSISTING TREATMENT OF DIFFERENT TYPES OF CANCER, LYMPHOGENIC LEUKEMIA, LUPUS ERYTHEMATODES, AND DIABETES MELLITUS, FOR THE ASSISTING TREATMENT OF CORONARY HEART DISEASE, CORONARY INSUFFICIENCIES, AND LIPID METABOLIC DISORDERS, AND FOR THE TREATMENT OR THE ASSISTING TREATMENT OF DEGENERATIVE BONE DISEASES, RHEUMATOID ARTHRITIS, AND BONE METASTASES OF TUMORS; DIETETIC FOODS ADAPTED FOR MEDICAL USE; MINERAL FOOD SUPPLEMENTS; VITAMIN PREPARATIONS (U.S. CLS. 6, 18, 44, 46, 51 AND 52).

ANGELA DUONG, EXAMINING ATTORNEY

SN 85-130,184. STACOR BIOSCIENCES, LLC, HUGHESVILLE, MD. FILED 9-15-2010.

BICARDIA

THE MARK CONSISTS OF STANDARD CHARACTERS WITHOUT CLAIM TO ANY PARTICULAR FONT, STYLE, SIZE, OR COLOR.

FOR DIETARY SUPPLEMENTS (U.S. CLS. 6, 18, 44, 46, 51 AND 52).

FIRST USE 9-14-2007; IN COMMERCE 9-14-2007.

COLLEEN KEARNEY, EXAMINING ATTORNEY

CLASS 5—(Continued).

SN 85-130,808. ALLIANCE PHARMACEUTICALS LIMITED, CHIPPENHAM, WILTSHIRE, UNITED KINGDOM, FILED 9-16-2010.

FRACTAR

THE MARK CONSISTS OF STANDARD CHARACTERS WITHOUT CLAIM TO ANY PARTICULAR FONT, STYLE, SIZE, OR COLOR.

PRIORITY CLAIMED UNDER SEC. 44(D) ON UNITED KINGDOM APPLICATION NO. 2541924, FILED 3-16-2010, REG. NO. 2541924, DATED 3-16-2010, EXPIRES 3-16-2020.

FOR COAL TAR EXTRACTS FOR USE AS AN INGREDIENT OF PHARMACEUTICAL PREPARATIONS FOR THE TREATMENT OF THE SCALP, SEBORRHEIC DERMATITIS AND PSORIASIS (U.S. CLS. 6, 18, 44, 46, 51 AND 52).

ROSELLE HERRERA, EXAMINING ATTORNEY

SN 85-130,817. ALLIANCE PHARMACEUTICALS LIMITED, CHIPPENHAM, WILTSHIRE, UNITED KINGDOM, FILED 9-16-2010.

FRACTAR 5

THE MARK CONSISTS OF STANDARD CHARACTERS WITHOUT CLAIM TO ANY PARTICULAR FONT, STYLE, SIZE, OR COLOR.

PRIORITY CLAIMED UNDER SEC. 44(D) ON UNITED KINGDOM APPLICATION NO. 2541924, FILED 3-16-2010, REG. NO. 2541924, DATED 3-16-2010, EXPIRES 3-16-2020.

FOR COAL TAR EXTRACTS FOR USE AS AN INGREDIENT OF PHARMACEUTICAL PREPARATIONS FOR THE TREATMENT OF THE SCALP, SEBORRHEIC DERMATITIS AND PSORIASIS (U.S. CLS. 6, 18, 44, 46, 51 AND 52).

ROSELLE HERRERA, EXAMINING ATTORNEY

SN 85-132,104. RECOVERY SCIENCE, LLC, HOLLYWOOD, MD. FILED 9-17-2010.

PROFOVEA

THE MARK CONSISTS OF STANDARD CHARACTERS WITHOUT CLAIM TO ANY PARTICULAR FONT, STYLE, SIZE, OR COLOR.

FOR DIETARY SUPPLEMENTS (U.S. CLS. 6, 18, 44, 46, 51 AND 52).

FIRST USE 12-31-2007; IN COMMERCE 12-31-2007.
NICHOLAS COLEMAN, EXAMINING ATTORNEY

CLASS 5—(Continued).

SN 85-133,817. LAFEVER COMPANY, CORNELL, IL. FILED 9-20-2010.

EMERAID SUSTAIN

THE MARK CONSISTS OF STANDARD CHARACTERS WITHOUT CLAIM TO ANY PARTICULAR FONT, STYLE, SIZE, OR COLOR.

OWNER OF U.S. REG. NO. 2,577,675.

FOR VETERINARY PREPARATIONS FOR THE FEEDING OF DEBILITATED ANIMALS, NAMELY, THE PROVISION OF LIFE-SAVING HIGHLY DIGESTIBLE NUTRITION TO THESE DEBILITATED ANIMALS THAT CAN MAINTAIN DEBILITATED ANIMALS FOR EXTENDED PERIODS OF TIME (U.S. CLS. 6, 18, 44, 46, 51 AND 52).

NAKWAMA ANKRAH, EXAMINING ATTORNEY

SN 85-133,821. LAFEVER COMPANY, CORNELL, IL. FILED 9-20-2010.

SUSTAIN

THE MARK CONSISTS OF STANDARD CHARACTERS WITHOUT CLAIM TO ANY PARTICULAR FONT, STYLE, SIZE, OR COLOR.

FOR VETERINARY PREPARATIONS FOR THE FEEDING OF DEBILITATED ANIMALS, NAMELY, THE PROVISION OF LIFE-SAVING HIGHLY DIGESTIBLE NUTRITION TO THESE DEBILITATED ANIMALS THAT CAN MAINTAIN DEBILITATED ANIMALS FOR EXTENDED PERIODS OF TIME (U.S. CLS. 6, 18, 44, 46, 51 AND 52).

NAKWAMA ANKRAH, EXAMINING ATTORNEY

CLASS 5—(Continued).

SN 85-136,028. INTELLECTUAL PROPERTY DEVELOPMENT CORPORATION PTY LTD, MELBOURNE, AUSTRALIA, FILED 9-22-2010.

HOSPITAL PLUS

THE MARK CONSISTS OF STANDARD CHARACTERS WITHOUT CLAIM TO ANY PARTICULAR FONT, STYLE, SIZE, OR COLOR.

OWNER OF AUSTRALIA REG. NO. 1352168, DATED 3-23-2010, EXPIRES 3-23-2020.

NO CLAIM IS MADE TO THE EXCLUSIVE RIGHT TO USE "HOSPITAL", APART FROM THE MARK AS SHOWN.

FOR GERMICIDE CLEANERS OTHER THAN SOAP; GERMICIDE PREPARATIONS OTHER THAN SOAP; GERMICIDES FOR PERSONAL USE OTHER THAN SOAP; GERMICIDES; MIXTURES OF GERMICIDES AND ANTISEPTICS IN OINTMENT FORM; SWABS IMPREGNATED WITH GERMICIDES FOR MEDICAL USE; ANTISEPTIC CLEANSERS; STERILIZING PREPARATIONS FOR DENTAL INSTRUMENTS; STERILIZING PREPARATIONS FOR SURGICAL INSTRUMENTS; IMPREGNATED MEDICATED TISSUES FOR CLEANING; LIQUID CLEANING COMPOSITIONS FOR CONTACT LENS; MEDICATED LIQUID PREPARATIONS FOR CLEANING THE HANDS; MEDICATED CLEANSING PREPARATIONS FOR THE SKIN OTHER THAN SOAP; MEDICATED CREAM CLEANERS; MEDICATED CREAMS FOR CLEANING THE SKIN; MEDICATED GEL FOR CLEANING THE SKIN; NON-SOAPY CLEANSING PREPARATIONS FOR MEDICAL USE; MEDICATED PREPARATIONS FOR ORAL CLEANING, OTHER THAN DENTIFRICES; MEDICATED PREPARATIONS IN GEL FORM FOR CLEANSING THE BODY; MEDICATED SKIN CLEANERS; MEDICATED SKIN CLEANSERS; SOLUTIONS FOR CLEANING CONTACT LENSES; DISINFECTANT WIPES FOR HYGIENIC CLEANING PURPOSES; AIR CARE PRODUCTS, NAMELY, AIR FRESHENERS, AIR DEODORIZERS, AIR PURIFIERS AND AIR DISINFECTANTS; PREPARATIONS FOR DEODORIZING; AIR FRESHENING AND AIR CARE PREPARATIONS AND PRODUCTS, NAMELY, AEROSOLS AND GELS, AIR PURIFYING PREPARATIONS AND PRODUCTS, NAMELY, AEROSOLS AND GELS; ANTISEPTICS; BATH SALTS FOR MEDICAL PURPOSES; SANITARY PREPARATIONS AND CHEMICAL PREPARATIONS FOR MEDICAL OR PHARMACEUTICAL PURPOSES; MEDICATED TOOTH-PASTE; DIETETIC FOODS AND BEVERAGES ADAPTED FOR MEDICAL PURPOSES; ALL PURPOSE DISINFECTANTS; BABY FOOD; FUMIGATION PREPARATIONS IN THE NATURE OF FUNGICIDES, BIOCIDES, GERMICIDES, HERBICIDES; HERBS FOR MEDICINAL PURPOSES; MEDICATED MOUTHWASH AND SKINCARE PREPARATIONS; SANITARY STERILIZING PREPARATIONS; VITAMIN PREPARATIONS; SANITIZING WIPES; DISINFECTANTS FOR USE IN WASHING APPARATUS OTHER THAN DISINFECTANT SOAP; DISINFECTANTS FOR USE ON THE PERSON OTHER

CLASS 5—(Continued).

THAN DISINFECTANT SOAP; DISINFECTANTS IMPREGNATED INTO TISSUES; DISINFECTING AGENTS OTHER THAN DISINFECTANT SOAP, NAMELY, HOUSEHOLD DISINFECTANTS; IMPREGNATED PAPER FOR DISINFECTING; IMPREGNATED TOWELS CONTAINING DISINFECTANT PREPARATIONS; LIQUID PREPARATIONS FOR THE DISINFECTION OF DENTAL APPARATUS; LIQUID PREPARATIONS FOR THE DISINFECTION OF MEDICAL APPARATUS; PREPARATIONS FOR DISINFECTING SKIN; PREPARATIONS FOR DISINFECTING WATER; PREPARATIONS FOR USE IN DISINFECTING FOR USE IN THE HOME; DISINFECTING PREPARATIONS FOR USE IN HYGIENE; SANITARY CHEMICAL SUBSTANCES FOR DISINFECTING; SPONGES IMPREGNATED WITH DISINFECTANT; SPRAYS OF PROTECTIVE FILM FORMING MATERIAL FOR DISINFECTING PURPOSES; DISINFECTING WIPES FOR MEDICAL HYGIENIC PURPOSES; DISINFECTING WIPES FOR MEDICAL USE; DISINFECTING WIPES FOR SURGICAL USE (U.S. CLS. 6, 18, 44, 46, 51 AND 52).

MORGAN WYNNE, EXAMINING ATTORNEY

SN 85-136,842. LABORATORIOS SANFER S.A. DE C.V., COL. TLACOPAC, MEXICO, FILED 9-23-2010.



PRIORITY CLAIMED UNDER SEC. 44(D) ON MEXICO APPLICATION NO. 1115069, FILED 8-26-2010.

OWNER OF MEXICO REG. NO. 1115069, DATED 9-28-2010, EXPIRES 8-26-2020.

OWNER OF MEXICO REG. NO. 1181620, DATED 9-28-2010, EXPIRES 8-26-2020.

THE COLOR(S) RED, BLUE, WHITE IS/ARE CLAIMED AS A FEATURE OF THE MARK.

THE MARK CONSISTS OF THE TERM "TREDA" IN RED CENTERED AND FLUSH TO THE LEFT MARGIN WITH AN ARCED RED PORTION WITH WHITE SHADING EXTENDING FROM THE TOP TO THE BOTTOM OF THE PAGE IN THE RIGHT MARGIN WITH A BLUE CIRCLE UNDERNEATH THE "A" OF THE TERM "TREDA" WITH A RED IDENTIFYING SYMBOL COMPRISED OF A HUMAN INTESTINE INSIDE THE BLUE CIRCLE.

FOR MEDICINES AND PHARMACEUTICAL PREPARATIONS, NAMELY, A PHARMACEUTICAL PRODUCT FOR DIARRHEA TREATMENT (U.S. CLS. 6, 18, 44, 46, 51 AND 52).

LEIGH CAROLINE CASE, EXAMINING ATTORNEY

CLASS 5—(Continued).

SN 85-139,259. MADRE LABS, INC., IRWINDALE, CA. FILED 9-27-2010.

Madre-C

THE MARK CONSISTS OF STANDARD CHARACTERS WITHOUT CLAIM TO ANY PARTICULAR FONT, STYLE, SIZE, OR COLOR.

OWNER OF U.S. REG. NO. 3,667,723.

THE ENGLISH TRANSLATION OF "MADRE" IN THE MARK IS "MOTHER".

FOR DIETARY AND NUTRITIONAL SUPPLEMENTS CONTAINING VITAMIN C (U.S. CLS. 6, 18, 44, 46, 51 AND 52).

FIRST USE 6-22-2009; IN COMMERCE 6-22-2009.

WILLIAM VERHOSEK, EXAMINING ATTORNEY

SN 85-140,086. VICURON PHARMACEUTICALS INC., NEW YORK, NY. FILED 9-28-2010.

EXULETT

THE MARK CONSISTS OF STANDARD CHARACTERS WITHOUT CLAIM TO ANY PARTICULAR FONT, STYLE, SIZE, OR COLOR.

FOR ANTIBIOTIC PREPARATIONS (U.S. CLS. 6, 18, 44, 46, 51 AND 52).

JAMES A. RAUEN, EXAMINING ATTORNEY

SN 85-149,063. PARAS PHARMACEUTICALS LIMITED, AHMEDABAD, INDIA, FILED 10-9-2010.



NO CLAIM IS MADE TO THE EXCLUSIVE RIGHT TO USE "ITCH", "CREAM", AND THE NON-LATIN CHARACTERS THAT TRANSLITERATE TO "ICH" AND "KRIM", APART FROM THE MARK AS SHOWN.

THE MARK CONSISTS OF THE STYLIZED WORDS "ITCH GUARD" WITH THE DESIGN OF A CIRCLE TO THE RIGHT CONTAINING A CACTUS SHAPE AND THE WORD "CREAM" ABOVE "GUARD". HINDI CHARACTERS APPEAR IN THE UPPER-LEFT CORNER.

THE NON-LATIN CHARACTERS IN THE MARK TRANSLITERATE TO "ICH GARD KRIM" AND THIS MEANS "ITCH GUARD CREAM" IN ENGLISH.

FOR MEDICATED SKIN CARE PREPARATIONS FOR THE TREATMENT OF SKIN INFLAMMATION, ITCHING, AND SKIN DISORDERS (U.S. CLS. 6, 18, 44, 46, 51 AND 52).

APRIL HESIK, EXAMINING ATTORNEY

CLASS 5—(Continued).

SN 85-149,064. PARAS PHARMACEUTICALS LIMITED, AHMEDABAD, INDIA, FILED 10-9-2010.



NO CLAIM IS MADE TO THE EXCLUSIVE RIGHT TO USE "RING", "DOUBLE ACTION ANTI-FUNGAL", "FIGHTS FUNGUS & GRAM POSITIVE BACTERIA", AND THE NON-LATIN CHARACTERS THAT TRANSLITERATE TO "RING", APART FROM THE MARK AS SHOWN.

THE MARK CONSISTS OF THE STYLIZED WORDS "RING GUARD DOUBLE ACTION ANTI-FUNGAL FIGHTS FUNGUS & GRAM POSITIVE BACTERIA" CONTAINED IN A RECTANGLE DIVIDED INTO FOUR RECTANGLES, WITH "RING" CONTAINED WITHIN THE UPPER-LEFT RECTANGLE, "GUARD DOUBLE ACTION ANTI-FUNGAL" CONTAINED WITHIN THE UPPER-RIGHT RECTANGLE, HINDI CHARACTERS APPEARING WITHIN THE LOWER-LEFT RECTANGLE, AND "FIGHTS FUNGUS & GRAM POSITIVE BACTERIA" CONTAINED WITHIN THE LOWER-RIGHT RECTANGLE. THE WORDING "DOUBLE ACTION" APPEARS ON A DOWNWARD LEFT-POINTING ARROW, AND THE WORDING "ANTI-FUNGAL" APPEARS ON AN UPWARD RIGHT-POINTING ARROW.

THE NON-LATIN CHARACTERS IN THE MARK TRANSLITERATE TO "RING GARD" AND THIS MEANS "RING GUARD" IN ENGLISH.

FOR MEDICATED SKIN CARE PREPARATIONS FOR THE TREATMENT OF SKIN INFECTIONS AND SKIN DISORDERS (U.S. CLS. 6, 18, 44, 46, 51 AND 52).

APRIL HESIK, EXAMINING ATTORNEY

SN 85-154,891. BRAINSTORM CELL THERAPEUTICS INC., NEW YORK, NY. FILED 10-18-2010.

NUROWN

THE MARK CONSISTS OF STANDARD CHARACTERS WITHOUT CLAIM TO ANY PARTICULAR FONT, STYLE, SIZE, OR COLOR.

FOR COMPOSITIONS OF STEM CELLS, NAMELY, DERIVED CELLS FOR MEDICAL OR CLINICAL USE (U.S. CLS. 6, 18, 44, 46, 51 AND 52).

LOURDES AYALA, EXAMINING ATTORNEY

SN 85-155,478. VERTEX PHARMACEUTICALS INCORPORATED, CAMBRIDGE, MA. FILED 10-18-2010.

KALYDECO

THE MARK CONSISTS OF STANDARD CHARACTERS WITHOUT CLAIM TO ANY PARTICULAR FONT, STYLE, SIZE, OR COLOR.

FOR PHARMACEUTICAL PREPARATIONS FOR THE TREATMENT OF CYSTIC FIBROSIS (U.S. CLS. 6, 18, 44, 46, 51 AND 52).

GRETTA YAO, EXAMINING ATTORNEY

CLASS 5—(Continued).

SN 85-171,329. ABBOTT LABORATORIES, ABBOTT PARK, IL. FILED 11-8-2010.

FOCUSED, CLINICAL NUTRITION

THE MARK CONSISTS OF STANDARD CHARACTERS WITHOUT CLAIM TO ANY PARTICULAR FONT, STYLE, SIZE, OR COLOR.

NO CLAIM IS MADE TO THE EXCLUSIVE RIGHT TO USE "NUTRITION", APART FROM THE MARK AS SHOWN.

FOR LIQUID AND POWDER NUTRITIVE SUPPLEMENTS FOR HUMAN USE (U.S. CLS. 6, 18, 44, 46, 51 AND 52).

KATHERINE CHANG, EXAMINING ATTORNEY

SN 85-175,178. BASF CORPORATION, FLORHAM PARK, NJ. FILED 11-12-2010.

SMARTCAP TECHNOLOGY

THE MARK CONSISTS OF STANDARD CHARACTERS WITHOUT CLAIM TO ANY PARTICULAR FONT, STYLE, SIZE, OR COLOR.

NO CLAIM IS MADE TO THE EXCLUSIVE RIGHT TO USE "TECHNOLOGY", APART FROM THE MARK AS SHOWN.

FOR PREPARATIONS FOR DESTROYING AND COMBATING VERMIN, FUNGICIDES, HERBICIDES, PESTICIDES (U.S. CLS. 6, 18, 44, 46, 51 AND 52).

MORGAN WYNNE, EXAMINING ATTORNEY

SN 85-176,510. PREZACOR, INC., PRINCETON, NJ. FILED 11-15-2010.

ENERGEZICS

THE MARK CONSISTS OF STANDARD CHARACTERS WITHOUT CLAIM TO ANY PARTICULAR FONT, STYLE, SIZE, OR COLOR.

FOR ANALGESIC CREAMS; BANDAGES IMPREGNATED WITH ANALGESIC PREPARATIONS IN THE NATURE OF DRESSINGS FOR CLINICAL PAIN SYNDROMES; ANALGESIC DEVICES, NAMELY, WRAPS CONTAINING GELS, SOLIDS, AND CREAMS FOR THE TREATMENT OF PAIN (U.S. CLS. 6, 18, 44, 46, 51 AND 52).

TASNEEM HUSSAIN, EXAMINING ATTORNEY

CLASS 5—(Continued).

SN 85-176,539. PREZACOR, INC., PRINCETON, NJ. FILED 11-15-2010.

ENERGEZE

THE MARK CONSISTS OF STANDARD CHARACTERS WITHOUT CLAIM TO ANY PARTICULAR FONT, STYLE, SIZE, OR COLOR.

FOR ANALGESIC CREAMS; BANDAGES IMPREGNATED WITH ANALGESIC PREPARATIONS IN THE NATURE OF DRESSINGS FOR CLINICAL PAIN SYNDROMES; ANALGESIC DEVICES, NAMELY, WRAPS CONTAINING GELS, SOLIDS, AND CREAMS FOR THE TREATMENT OF PAIN (U.S. CLS. 6, 18, 44, 46, 51 AND 52).

TASNEEM HUSSAIN, EXAMINING ATTORNEY

SN 85-178,656. BAYER SCHERING PHARMA AG, BERLIN, FED REP GERMANY, FILED 11-17-2010.

YALISCA

THE MARK CONSISTS OF STANDARD CHARACTERS WITHOUT CLAIM TO ANY PARTICULAR FONT, STYLE, SIZE, OR COLOR.

FOR PHARMACEUTICAL PREPARATIONS, NAMELY, HORMONAL PREPARATIONS (U.S. CLS. 6, 18, 44, 46, 51 AND 52).

ANTHONY RINKER, EXAMINING ATTORNEY

CLASS 5—(Continued).

SN 85-202,457. IMCLONE LLC, NEW YORK, NY. FILED 12-21-2010.

CIRAMZA

THE MARK CONSISTS OF STANDARD CHARACTERS WITHOUT CLAIM TO ANY PARTICULAR FONT, STYLE, SIZE, OR COLOR.

FOR PHARMACEUTICAL PREPARATIONS, NAMELY, PHARMACEUTICAL PREPARATIONS FOR THE TREATMENT OF ALCOHOL USE DISORDERS, ANXIETY, BONE AND SKELETAL DISEASES AND DISORDERS, BLOOD DISORDERS, CANCER, CARDIOVASCULAR DISEASES, CHOLESTEROL DISORDERS, CENTRAL NERVOUS SYSTEM DISEASES AND DISORDERS, DIABETES, ENDOCRINE DISEASES AND DISORDERS, GASTROINTESTINAL DISEASES AND DISORDERS, HORMONAL DISEASES AND DISORDERS, INFLAMMATION AND INFLAMMATORY DISEASES AND DISORDERS, LIVER DISEASES AND DISORDERS, KIDNEY DISEASES AND DISORDERS, NEURODEGENERATIVE DISEASES AND DISORDERS, NEUROLOGICAL DISORDERS, OBESITY, PAIN, REPRODUCTIVE SYSTEM DISEASES AND DISORDERS, UROLOGICAL DISORDERS, DYSLIPIDEMIA, SLEEP DISORDERS, MIGRAINES, METABOLIC DISEASES AND DISORDERS; ANTIPSYCHOTICS; ANTIDEPRESSANTS; ANXIETY SPECTRUM DISORDERS; ATHEROSCLEROSIS; ALZHEIMER'S; PHARMACEUTICAL PREPARATIONS FOR USE IN THE TREATMENT OF DIABETES; PHARMACEUTICAL PREPARATIONS FOR USE IN THE TREATMENT OF RHEUMATOID ARTHRITIS; PHARMACEUTICAL PREPARATIONS FOR USE IN THE TREATMENT OF CROHN'S DISEASE, SYSTEMIC LUPUS ERYTHEMATOSUS, AND ANKYLOSING SPONDYLITIS DISEASE; PHARMACEUTICAL PREPARATIONS FOR USE IN THE TREATMENT OF PSORIASIS AND PSORIATIC ARTHRITIS; PHARMACEUTICAL PREPARATIONS FOR USE IN THE TREATMENT OF AUTOIMMUNE DISORDERS (U.S. CLS. 6, 18, 44, 46, 51 AND 52).

CHERYL CLAYTON, EXAMINING ATTORNEY

CLASS 5—(Continued).

SN 85-202,772. COMERCIALIZADORA MD, S.A. DE C.V., ZAPOPAN, JALISCO, MEXICO, FILED 12-21-2010.

RosaVit C



OWNER OF MEXICO REG. NO. 1168531, DATED 1-22-2010, EXPIRES 1-22-2020.

NO CLAIM IS MADE TO THE EXCLUSIVE RIGHT TO USE "C", APART FROM THE MARK AS SHOWN.

THE MARK CONSISTS OF THE TERM "ROSAVIT C" IN STYLIZED FONT DIRECTLY BENEATH A HORIZONTAL LINE. BELOW THE WORDING IS ANOTHER, LONGER HORIZONTAL LINE. AT THE BOTTOM LEFT OF THE MARK IS AN ABSTRACT DRAWING OF A ROSE WITH TWO LEAVES AND A SLICE OF CITRUS FRUIT. BELOW THE DRAWING IS ANOTHER, THICKER HORIZONTAL LINE THAT ACTS AS THE BASE OF THE MARK.

FOR NATURAL REMEDY PREPARATIONS CONTAINING VITAMIN C FOR THE TREATMENT OF COLD AND FLU (U.S. CLS. 6, 18, 44, 46, 51 AND 52).

NAKWAMA ANKRAH, EXAMINING ATTORNEY

SN 85-205,874. TRINETRA, INC., FRESNO, CA. FILED 12-27-2010.

ACIDEN

THE MARK CONSISTS OF STANDARD CHARACTERS WITHOUT CLAIM TO ANY PARTICULAR FONT, STYLE, SIZE, OR COLOR.

THE WORD "ACIDEN" HAS NO MEANING IN A FOREIGN LANGUAGE

FOR DIETARY SUPPLEMENTS (U.S. CLS. 6, 18, 44, 46, 51 AND 52).

FIRST USE 9-1-2010; IN COMMERCE 9-15-2010.

ELI HELLMAN, EXAMINING ATTORNEY

CLASS 5—(Continued).

SN 85-214,754. GLAXO GROUP LIMITED, GREENFORD, MIDDLESEX, UNITED KINGDOM, FILED 1-11-2011.

VENABRES

THE MARK CONSISTS OF STANDARD CHARACTERS WITHOUT CLAIM TO ANY PARTICULAR FONT, STYLE, SIZE, OR COLOR.

THE WORD(S) "VENABRES" HAS NO MEANING IN A FOREIGN LANGUAGE.

FOR PHARMACEUTICAL PREPARATIONS AND SUBSTANCES FOR THE TREATMENT OF DAMAGED SKIN AND TISSUE; PHARMACEUTICAL PREPARATIONS AND SUBSTANCES FOR THE TREATMENT OF INFECTIOUS DISEASES, BLOOD DISORDERS, PAIN, INFLAMMATION, SEPSIS, ALOPECIA, OBESITY AND COGNITIVE DISORDERS; PHARMACEUTICAL PREPARATIONS AND SUBSTANCES FOR THE TREATMENT OF VIRAL, METABOLIC, ENDOCRINE, MUSCULOSKELETAL, CARDIOVASCULAR, CARDIO-PULMONARY, GENITOURINARY, SEXUAL DYSFUNCTION, ONCOLOGICAL, HEPATOLOGICAL, OPHTHALMIC, RESPIRATORY, NEUROLOGICAL, GASTROINTESTINAL, HORMONAL, DERMATOLOGICAL, PSYCHIATRIC AND IMMUNE SYSTEM RELATED DISEASES AND DISORDERS; VACCINES (U.S. CLS. 6, 18, 44, 46, 51 AND 52).

MEGHAN REINHART, EXAMINING ATTORNEY

SN 85-217,130. PUREBRANDS, LLC, BOCA RATON, FL. FILED 1-13-2011.

PROPATCH

THE MARK CONSISTS OF STANDARD CHARACTERS WITHOUT CLAIM TO ANY PARTICULAR FONT, STYLE, SIZE, OR COLOR.

FOR TRANSDERMAL AND TOPICAL DELIVERY PATCHES WORN ON THE BODY CONTAINING NUTRITIONAL SUPPLEMENTS, DIETARY SUPPLEMENTS, VITAMIN AND MINERAL SUPPLEMENTS AND ANALGESICS (U.S. CLS. 6, 18, 44, 46, 51 AND 52).

FIRST USE 2-18-2011; IN COMMERCE 2-18-2011.
FLORENTINA BLANDU, EXAMINING ATTORNEY

CLASS 5—(Continued).

SN 85-217,200. RAINBOW LIGHT NUTRITIONAL SYSTEMS, INC., SANTA CRUZ, CA. FILED 1-13-2011.

ECO GUARD

THE MARK CONSISTS OF STANDARD CHARACTERS WITHOUT CLAIM TO ANY PARTICULAR FONT, STYLE, SIZE, OR COLOR.

FOR VITAMIN AND NUTRITIONAL SUPPLEMENTS SOLD IN BOTTLES (U.S. CLS. 6, 18, 44, 46, 51 AND 52).
FIRST USE 12-23-2009; IN COMMERCE 12-23-2009.
IRA J. GOODSaid, EXAMINING ATTORNEY

SN 85-220,682. PUREBRANDS, LLC, BOCA RATON, FL. FILED 1-19-2011.



THE MARK CONSISTS OF A DESIGN OF A HAND PUTTING A STRIP ON A TONGUE.

FOR DISSOLVABLE ORAL STRIPS CONTAINING NUTRIENTS, VITAMINS, SUPPLEMENTS, ANALGESICS, ETC (U.S. CLS. 6, 18, 44, 46, 51 AND 52).

FIRST USE 5-27-2011; IN COMMERCE 5-27-2011.
FLORENTINA BLANDU, EXAMINING ATTORNEY

SN 85-223,215. RAINBOW LIGHT NUTRITIONAL SYSTEMS, INC., SANTA CRUZ, CA. FILED 1-21-2011.



THE MARK CONSISTS OF THE WORDING "ECO . GUARD" AND AN EARTH GLOBE WITH THE OUTLINE OF CONTINENTS ON IT, WITH TWO LEAVES ABOVE AND BELOW THE GLOBE.

FOR VITAMIN AND NUTRITIONAL SUPPLEMENTS SOLD IN BOTTLES (U.S. CLS. 6, 18, 44, 46, 51 AND 52).
IRA J. GOODSaid, EXAMINING ATTORNEY

CLASS 5—(Continued).

SN 85-229,640. MOELLEKEN, WOLFGANG W., SANTA BARBARA, CA. FILED 1-30-2011.

KOLLASTIN

THE MARK CONSISTS OF STANDARD CHARACTERS WITHOUT CLAIM TO ANY PARTICULAR FONT, STYLE, SIZE, OR COLOR.

THE WORDING "KOLLASTIN" HAS NO MEANING IN A FOREIGN LANGUAGE.

FOR INGREDIENT COMPLEX FOR NON-MEDICAL SKIN CARE PREPARATIONS, NAMELY, FACE CREAMS, GELS AND LOTIONS; NON-MEDICATED BLEMISH AND ACNE TREATMENT CREAMS, GELS, AND LOTIONS; CLEANSING CREAMS, GELS, AND LOTIONS (U.S. CLS. 6, 18, 44, 46, 51 AND 52).

FIRST USE 12-1-2010; IN COMMERCE 12-1-2010.
RONALD AIKENS, EXAMINING ATTORNEY

CLASS 5—(Continued).

SN 85-236,367. IRVINE SCIENTIFIC SALES CO., INC., SANTA ANA, CA. FILED 2-8-2011.

PH SECURE

THE MARK CONSISTS OF STANDARD CHARACTERS WITHOUT CLAIM TO ANY PARTICULAR FONT, STYLE, SIZE, OR COLOR.

NO CLAIM IS MADE TO THE EXCLUSIVE RIGHT TO USE "PH", APART FROM THE MARK AS SHOWN.

FOR TISSUE CULTURE MEDIA FOR RESEARCH AND LABORATORY USE AND FOR CLINICAL AND MEDICAL LABORATORY USE (U.S. CLS. 6, 18, 44, 46, 51 AND 52).

FIRST USE 4-20-2011; IN COMMERCE 4-20-2011.
JENNY PARK, EXAMINING ATTORNEY

SN 85-235,803. TAKEDA PHARMACEUTICAL COMPANY LIMITED, CHUO-KU, OSAKA, JAPAN, FILED 2-7-2011.

MSENI

THE MARK CONSISTS OF STANDARD CHARACTERS WITHOUT CLAIM TO ANY PARTICULAR FONT, STYLE, SIZE, OR COLOR.

PRIORITY CLAIMED UNDER SEC. 44(D) ON JAPAN APPLICATION NO. 2011-001688, FILED 1-13-2011, REG. NO. 5419683, DATED 6-17-2011, EXPIRES 6-17-2021.

THE WORDING "MSENI" HAS NO MEANING IN A FOREIGN LANGUAGE.

FOR PHARMACEUTICAL PREPARATIONS FOR THE TREATMENT AND PREVENTION OF DIABETIC DISEASES (U.S. CLS. 6, 18, 44, 46, 51 AND 52).

WON TEAK OH, EXAMINING ATTORNEY

SN 85-236,610. MAITA, JOSEPH, DBA HEAVEN'S WHEY, YORKTOWN HIGHTS, NY. FILED 2-8-2011.



OWNER OF U.S. REG. NO. 2,767,603.

NO CLAIM IS MADE TO THE EXCLUSIVE RIGHT TO USE "WHEY INC." AND "SNACK", APART FROM THE MARK AS SHOWN.

THE COLOR(S) BEIGE, BROWN AND RED IS/ARE CLAIMED AS A FEATURE OF THE MARK.

THE MARK CONSISTS OF THE RED STYLIZED WORDS "HEAVEN'S WHEY INC." CENTERED ABOVE THE WORDS "A BETTER WAY TO SNACK" IN RED STYLIZED ITALIC FONT. ABOVE THE WORDS IS A DRAWING OF A BROWN TRIANGLE BEHIND A RED HEART WITH A BEIGE CHEF'S HAT, BEIGE HALO AND BEIGE WINGS.

FOR DIETARY AND NUTRITIONAL SUPPLEMENTS CONTAINING WHEY SOLD AS AN INTEGRAL COMPONENT BAKED INTO COOKIES, SNACK BARS AND OTHER BAKED GOODS; NUTRITIONAL SUPPLEMENTS CONTAINING WHEY SOLD AS AN INTEGRAL COMPONENT BAKED INTO COOKIES, SNACK BARS AND OTHER BAKED GOODS; PROTEIN SUPPLEMENTS CONTAINING WHEY SOLD AS AN INTEGRAL COMPONENT BAKED INTO COOKIES, SNACK BARS AND OTHER BAKED GOODS; WHEY PROTEIN SUPPLEMENTS SOLD AS AN INTEGRAL COMPONENT BAKED INTO COOKIES, SNACK BARS AND OTHER BAKED GOODS (U.S. CLS. 6, 18, 44, 46, 51 AND 52).

FIRST USE 6-21-2002; IN COMMERCE 6-21-2002.
MARLENE BELL, EXAMINING ATTORNEY

SN 85-235,848. TAKEDA PHARMACEUTICAL COMPANY LIMITED, CHUO-KU, OSAKA, JAPAN, FILED 2-7-2011.

NESMETA

THE MARK CONSISTS OF STANDARD CHARACTERS WITHOUT CLAIM TO ANY PARTICULAR FONT, STYLE, SIZE, OR COLOR.

PRIORITY CLAIMED UNDER SEC. 44(D) ON JAPAN APPLICATION NO. 2011-001699, FILED 1-13-2011, REG. NO. 5419691, DATED 6-17-2011, EXPIRES 6-17-2021.

THE WORDING "NESMETA" HAS NO MEANING IN A FOREIGN LANGUAGE.

FOR PHARMACEUTICAL PREPARATIONS FOR THE TREATMENT AND PREVENTION OF DIABETIC DISEASES (U.S. CLS. 6, 18, 44, 46, 51 AND 52).

WON TEAK OH, EXAMINING ATTORNEY

CLASS 5—(Continued).

SN 85-240,295. THE HARTZ MOUNTAIN CORPORATION, SECAUCUS, NY. FILED 2-11-2011.

HARTZ PRO FORCE

THE MARK CONSISTS OF STANDARD CHARACTERS WITHOUT CLAIM TO ANY PARTICULAR FONT, STYLE, SIZE, OR COLOR.

OWNER OF U.S. REG. NOS. 782,948, 943,059 AND OTHERS.

FOR FLEA AND TICK KILLER CARPET POWDER FOR USE IN THE HOME; FLEA AND TICK KILLER SPRAY FOGGER FOR USE IN THE HOME; FLEA AND TICK KILLER SPRAY FOR USE ON THE DOG OR CAT, IN THE HOME AND IN THE YARD; MEDICATED FLEA AND TICK ERADICATION PRODUCTS FOR CATS AND DOGS, NAMELY, SHAMPOOS AND CONDITIONERS, DIPS, SPRAYS, COLLARS AND TOPICAL LIQUID DROPS, EXCLUDING PHARMACEUTICALS (U.S. CLS. 6, 18, 44, 46, 51 AND 52).

DAVID COLLIER, EXAMINING ATTORNEY

SN 85-242,313. THE HARTZ MOUNTAIN CORPORATION, SECAUCUS, NJ. FILED 2-15-2011.

ULTRAGUARD MAX

THE MARK CONSISTS OF STANDARD CHARACTERS WITHOUT CLAIM TO ANY PARTICULAR FONT, STYLE, SIZE, OR COLOR.

OWNER OF U.S. REG. NOS. 3,291,920, 3,437,850 AND 3,581,602.

FOR FLEA AND TICK CARPET POWDER FOR USE IN THE HOME; FLEA AND TICK KILLER SPRAY FOGGER FOR USE IN THE HOME; FLEA AND TICK KILLER SPRAY FOR USE ON THE DOG OR CAT, IN THE HOME AND IN THE YARD; MEDICATED FLEA AND TICK ERADICATION PRODUCTS FOR CATS AND DOGS, NAMELY, SHAMPOOS AND CONDITIONERS, DIPS, SPRAYS, COLLARS AND TOPICAL LIQUID DROPS, EXCLUDING PHARMACEUTICALS (U.S. CLS. 6, 18, 44, 46, 51 AND 52).

DAVID COLLIER, EXAMINING ATTORNEY

CLASS 5—(Continued).

SN 85-242,328. THE HARTZ MOUNTAIN CORPORATION, SECAUCUS, NJ. FILED 2-15-2011.

INCONTROL MAX

THE MARK CONSISTS OF STANDARD CHARACTERS WITHOUT CLAIM TO ANY PARTICULAR FONT, STYLE, SIZE, OR COLOR.

OWNER OF U.S. REG. NO. 3,632,784.

FOR FLEA AND TICK KILLER CARPET POWDER FOR USE IN THE HOME; FLEA AND TICK KILLER SPRAY FOGGER FOR USE IN THE HOME; FLEA AND TICK KILLER SPRAY FOR USE ON THE DOG OR CAT, IN THE HOME AND IN THE YARD; MEDICATED FLEA AND TICK ERADICATION PRODUCTS FOR CATS AND DOGS, NAMELY, SHAMPOOS AND CONDITIONERS, DIPS, SPRAYS, COLLARS AND TOPICAL LIQUID DROPS, EXCLUDING PHARMACEUTICALS (U.S. CLS. 6, 18, 44, 46, 51 AND 52).

DAVID COLLIER, EXAMINING ATTORNEY

SN 85-242,479. N.V. NUTRICIA, ZOETERMEER, NETHERLANDS, FILED 2-15-2011.

INFATRINI

THE MARK CONSISTS OF STANDARD CHARACTERS WITHOUT CLAIM TO ANY PARTICULAR FONT, STYLE, SIZE, OR COLOR.

OWNER OF ERPN CMNTY TM OFC REG. NO. 001497973, DATED 4-17-2001, EXPIRES 2-8-2020.

FOR DIETETIC FOODS ADAPTED FOR MEDICAL USE; DIETETIC BEVERAGES ADAPTED FOR MEDICAL USE; FOOD FOR BABIES (U.S. CLS. 6, 18, 44, 46, 51 AND 52).

JANICE L. MCMORROW, EXAMINING ATTORNEY

SN 85-243,996. TAKEDA PHARMACEUTICAL COMPANY LIMITED, CHUO-KU, OSAKA, JAPAN, FILED 2-16-2011.

NELSACT

THE MARK CONSISTS OF STANDARD CHARACTERS WITHOUT CLAIM TO ANY PARTICULAR FONT, STYLE, SIZE, OR COLOR.

OWNER OF JAPAN REG. NO. 5177545, DATED 10-31-2008, EXPIRES 10-31-2018.

THE WORDING "NELSACT" HAS NO MEANING IN A FOREIGN LANGUAGE.

FOR PHARMACEUTICAL PREPARATIONS FOR THE TREATMENT AND PREVENTION OF DIABETIC DISEASES (U.S. CLS. 6, 18, 44, 46, 51 AND 52).

WON TEAK OH, EXAMINING ATTORNEY

CLASS 5—(Continued).

SN 85-244,016. TAKEDA PHARMACEUTICAL COMPANY LIMITED, CHUO-KU, OSAKA, JAPAN, FILED 2-16-2011.

NEMISACT

THE MARK CONSISTS OF STANDARD CHARACTERS WITHOUT CLAIM TO ANY PARTICULAR FONT, STYLE, SIZE, OR COLOR.

OWNER OF JAPAN REG. NO. 5177548, DATED 10-31-2008, EXPIRES 10-31-2018.

THE WORDING "NEMISACT" HAS NO MEANING IN A FOREIGN LANGUAGE.

FOR PHARMACEUTICAL PREPARATIONS FOR THE TREATMENT AND PREVENTION OF DIABETIC DISEASES (U.S. CLS. 6, 18, 44, 46, 51 AND 52).

WON TEAK OH, EXAMINING ATTORNEY

CLASS 5—(Continued).

SN 85-256,185. SUN CHLORELLA CORP., SHIMOGYO-KU, KYOTO, JAPAN, FILED 3-2-2011.

Pulverized by Dyno-Mill

THE MARK CONSISTS OF STANDARD CHARACTERS WITHOUT CLAIM TO ANY PARTICULAR FONT, STYLE, SIZE, OR COLOR.

NO CLAIM IS MADE TO THE EXCLUSIVE RIGHT TO USE "PULVERIZED", APART FROM THE MARK AS SHOWN.

FOR DIETARY SUPPLEMENTS; NUTRITIONAL SUPPLEMENTS (U.S. CLS. 6, 18, 44, 46, 51 AND 52).

ALLISON SCHRODY, EXAMINING ATTORNEY

SN 85-250,550. BIRSECK PTY LTD, TRAFALGAR VIC 3824, AUSTRALIA, FILED 2-24-2011.

ISOMOOD

THE MARK CONSISTS OF STANDARD CHARACTERS WITHOUT CLAIM TO ANY PARTICULAR FONT, STYLE, SIZE, OR COLOR.

THE WORDING "ISOMOOD" HAS NO MEANING IN A FOREIGN LANGUAGE.

FOR HOMEOPATHIC PHARMACEUTICALS FOR STRESS, ANXIETY, NERVOUS TENSION AND MOOD SWINGS; HOMEOPATHIC PHARMACEUTICALS TO HELP QUIT SMOKING (U.S. CLS. 6, 18, 44, 46, 51 AND 52).

FIRST USE 10-11-2009; IN COMMERCE 1-20-2010.

MICHAEL SOUDERS, EXAMINING ATTORNEY

SN 85-256,195. SUN CHLORELLA CORP., SHIMOGYO-KU, KYOTO, JAPAN, FILED 3-2-2011.

**Pulverized Chlorella by
Dyno-Mill**

THE MARK CONSISTS OF STANDARD CHARACTERS WITHOUT CLAIM TO ANY PARTICULAR FONT, STYLE, SIZE, OR COLOR.

NO CLAIM IS MADE TO THE EXCLUSIVE RIGHT TO USE "PULVERIZED CHLORELLA", APART FROM THE MARK AS SHOWN.

FOR DIETARY SUPPLEMENTS AND NUTRITIONAL SUPPLEMENTS CONTAINING CHLORELLA (U.S. CLS. 6, 18, 44, 46, 51 AND 52).

ALLISON SCHRODY, EXAMINING ATTORNEY

SN 85-255,420. BAYER AKTIENGESELLSCHAFT, LEVERKUSEN, FED REP GERMANY, FILED 3-2-2011.

ZYLEMPHA

THE MARK CONSISTS OF STANDARD CHARACTERS WITHOUT CLAIM TO ANY PARTICULAR FONT, STYLE, SIZE, OR COLOR.

OWNER OF FED REP GERMANY REG. NO. 302010069616, DATED 2-10-2011, EXPIRES 11-30-2020.

FOR PHARMACEUTICAL PREPARATIONS AND SUBSTANCES FOR THE TREATMENT OF CANCER (U.S. CLS. 6, 18, 44, 46, 51 AND 52).

JACLYN KIDWELL WALKER, EXAMINING ATTORNEY

SN 85-256,206. SUN CHLORELLA CORP., SHIMOGYO-KU, KYOTO, JAPAN, FILED 3-2-2011.

Dyno-Milled Chlorella

THE MARK CONSISTS OF STANDARD CHARACTERS WITHOUT CLAIM TO ANY PARTICULAR FONT, STYLE, SIZE, OR COLOR.

NO CLAIM IS MADE TO THE EXCLUSIVE RIGHT TO USE "CHLORELLA", APART FROM THE MARK AS SHOWN.

FOR DIETARY SUPPLEMENTS AND NUTRITIONAL SUPPLEMENTS CONTAINING CHLORELLA (U.S. CLS. 6, 18, 44, 46, 51 AND 52).

ALLISON SCHRODY, EXAMINING ATTORNEY

CLASS 5—(Continued).

SN 85-256,221. SUN CHLORELLA CORP., SHIMOGYO-KU, KYOTO, JAPAN, FILED 3-2-2011.

Dyno-Mill Pulverized Process

THE MARK CONSISTS OF STANDARD CHARACTERS WITHOUT CLAIM TO ANY PARTICULAR FONT, STYLE, SIZE, OR COLOR.

NO CLAIM IS MADE TO THE EXCLUSIVE RIGHT TO USE "PULVERIZED PROCESS", APART FROM THE MARK AS SHOWN.

FOR DIETARY SUPPLEMENTS; NUTRITIONAL SUPPLEMENTS (U.S. CLS. 6, 18, 44, 46, 51 AND 52).
ALLISON SCHRODY, EXAMINING ATTORNEY

SN 85-256,547. N.V. NUTRICIA, ZOETERMEER, NETHERLANDS, FILED 3-3-2011.

NUTURIS

THE MARK CONSISTS OF STANDARD CHARACTERS WITHOUT CLAIM TO ANY PARTICULAR FONT, STYLE, SIZE, OR COLOR.

OWNER OF BENELUX REG. NO. 0887566, DATED 12-10-2010, EXPIRES 9-15-2020.

FOR DIETARY AND NUTRITIONALLY FORTIFIED FOOD PRODUCTS ADAPTED FOR MEDICAL USE; DIETETIC FOODS ADAPTED FOR MEDICAL USE; FOOD FOR BABIES; DIETARY AND NUTRITIONALLY FORTIFIED FOOD PRODUCTS ADAPTED FOR MEDICAL USE, NAMELY, MILK FOR PREGNANT AND LACTATING WOMEN; NUTRITIONAL SUPPLEMENTS; NUTRITIONAL SUPPLEMENTS FOR BABIES, INFANTS AND CHILDREN, FOR MEDICAL USE; MEDICATED SUPPLEMENTS FOR FOODSTUFFS FOR PREGNANT, LACTATING AND BREAST-FEEDING WOMEN; MEDICINAL DRINKS (U.S. CLS. 6, 18, 44, 46, 51 AND 52).
JANICE L. MCMORROW, EXAMINING ATTORNEY

SN 85-258,766. QFAC, RENO, NV. FILED 3-4-2011.



Protégé
LABORATORIES
Science meets Nutrition

NO CLAIM IS MADE TO THE EXCLUSIVE RIGHT TO USE "LABORATORIES", APART FROM THE MARK AS SHOWN.

THE COLOR(S) BLACK AND GREEN IS/ARE CLAIMED AS A FEATURE OF THE MARK.

THE MARK CONSISTS OF THE WORD "PROTÉGÉ"

CLASS 5—(Continued).

DISPLAYED IN A STYLIZED FONT WITH THE LETTERS "PRO" IN THE WORD "PROTÉGÉ" IN BLACK, THE LETTERS "TEGE" IN THE WORD "PROTÉGÉ" IN GREEN, AND THERE IS AN ACCENT AGUE LOCATED DIRECTLY ABOVE THE LETTER "E" IN BOTH PLACES IN THE WORD "PROTÉGÉ". BELOW THE WORD "PROTÉGÉ" IS THE STYLIZED WORD "LABORATORIES" IN BLACK AND DIRECTLY BELOW THE WORD "LABORATORIES", IS THE STYLIZED WORDING "SCIENCE MEETS NUTRITION" IN BLACK.

FOR ANTIOXIDANT DIETARY AND NUTRITIONAL SUPPLEMENTS AND SUPER ANTIOXIDANT DIETARY AND NUTRITIONAL SUPPLEMENTS; AMINO ACIDS FOR NUTRITIONAL PURPOSES; ANTI-INFLAMMATORIES; ANTI-INFLAMMATORY GELS; APPETITE SUPPRESSANTS; CREATINE NUTRITIONAL SUPPLEMENTS; DIETARY AND NUTRITIONAL SUPPLEMENTS, NAMELY, DIETARY AND NUTRITIONAL SUPPLEMENTS FOR ENDURANCE SPORTS AND WEIGHT LOSS, DIETARY SUPPLEMENTS IN THE NATURE OF WEIGHT LOSS POWDERS, SUPPLEMENTS FOR ELIMINATING TOXINS FROM THE INTESTINAL TRACT, SUPPLEMENTS FOR URINARY HEALTH, SUPPLEMENTS FOR ELIMINATING BACK PAIN, SUPPLEMENTS FOR ANIMALS, MEN, WOMEN, TEENAGERS, AND CHILDREN, CALCIUM SUPPLEMENTS, MAGNESIUM SUPPLEMENTS, PROTEIN SUPPLEMENTS, WHEY PROTEIN SUPPLEMENTS, HERBAL SUPPLEMENTS, HOMEOPATHIC SUPPLEMENTS, VITAMIN SUPPLEMENTS, NUTRITIONAL AND DIETARY SUPPLEMENTS CONTAINING SUPER FOODS AND SUPER FOOD EXTRACTS; DIETARY BEVERAGE SUPPLEMENTS FOR HUMAN CONSUMPTION IN LIQUID AND DRY MIX FORM FOR THERAPEUTIC PURPOSES; DIETARY FIBER AS AN ADDITIVE FOR FOOD PRODUCTS; ELECTROLYTES; ELECTROLYTE REPLACEMENT SOLUTIONS; FISH OIL DIETARY AND NUTRITIONAL SUPPLEMENTS IN THE FORM OF EMULSIFIED FISH OIL, LIQUID FISH OIL, AND FISH OIL CAPSULES; FOOD SUPPLEMENTS, NAMELY, ENZYME FOOD SUPPLEMENTS, ANTI-OXIDANTS, AND HEALTH FOOD SUPPLEMENTS; HAIR GROWTH STIMULANTS; HORMONE REPLACEMENT THERAPY PREPARATIONS; MINERAL SUPPLEMENTS, NAMELY, MINERAL NUTRITIONAL AND FOOD SUPPLEMENTS; MULTI-VITAMIN PREPARATIONS; MIXED VITAMIN PREPARATIONS; MEDIUM CHAIN TRIGLYCERIDES (MCT) OIL FOR USE AS DIETARY AND NUTRITIONAL SUPPLEMENTS; NUTRACEUTICALS FOR USE AS A DIETARY SUPPLEMENT; NUTRITIONALLY FORTIFIED BEVERAGES; NUTRITIONAL DRINKS, DRINK POWDERS AND SHAKES USED FOR MEAL REPLACEMENT; NUTRITIONAL SUPPLEMENTS, NAMELY, CARBOHYDRATES IN POWDERED FORM, PROBIOTIC COMPOSITIONS, NUTRITIONAL SUPPLEMENT IN THE NATURE OF A NUTRIENT-DENSE, PROTEIN-BASED DRINK MIX, NUTRITIONAL SUPPLEMENT FOR ELIMINATING TOXINS FROM THE BODY AND THE INTESTINAL TRACT; OMEGAS 3, 6, AND 9 DIETARY AND NUTRITIONAL SUPPLEMENTS; POWDERED NUTRITIONAL SUPPLEMENT DRINK MIX AND CONCENTRATE; POWDERED DIETARY SUPPLEMENTAL DRINK MIXES, NAMELY, FRUIT-FLAVORED, VEGETABLE FLAVORED, AND ANTIOXIDANT AND SUPER ANTIOXIDANT DRINK MIXES; PRENATAL VITAMINS; PREPARATION FOR THE RELIEF OF PAIN; SPORTS CREAM FOR RELIEF OF PAIN; VEGAN PROTEIN FOR USE AS A NUTRITIONAL SUPPLEMENT IN READY-TO-DRINK BEVERAGES; VITAMIN AND MINERAL SUPPLEMENTS; VITAMINS AND VITAMIN PREPARATIONS; VITAMINS AND DIETARY FOOD SUPPLEMENTS FOR ANIMALS; VITAMIN TABLETS; VITAMIN PREPARATIONS, NAMELY, VITAMIN B PREPARATIONS, VITAMIN C PREPARATIONS, VITAMIN D, AND VITAMIN K PREPARATIONS (U.S. CLS. 6, 18, 44, 46, 51 AND 52).

FIRST USE 1-3-2011; IN COMMERCE 1-3-2011.
KELLEY WELLS, EXAMINING ATTORNEY

CLASS 5—(Continued).

SN 85-259,603. THE DAILY WELLNESS COMPANY, HONOLULU, HI. FILED 3-7-2011.

AUCLAIR

THE MARK CONSISTS OF STANDARD CHARACTERS WITHOUT CLAIM TO ANY PARTICULAR FONT, STYLE, SIZE, OR COLOR.

THE ENGLISH TRANSLATION OF THE COMBINATION "AU" AND "CLAIR" IS "IN THE LIGHT".

FOR DIETARY AND NUTRITIONAL SUPPLEMENTS (U.S. CLS. 6, 18, 44, 46, 51 AND 52).

CYNTHIA SLOAN, EXAMINING ATTORNEY

SN 85-259,991. NUTRAMAX LABORATORIES, INC., EDGEWOOD, MD. FILED 3-7-2011.



OWNER OF U.S. REG. NO. 3,869,100.
NO CLAIM IS MADE TO THE EXCLUSIVE RIGHT TO USE "JOINT HEALTH #1 BRAND RECOMMENDED BY VETERINARIANS", APART FROM THE MARK AS SHOWN.

THE MARK CONSISTS OF AN INNER AND OUTER CIRCLE WITH THE WORDS "JOINT HEALTH" IN THE OUTER CIRCLE; THE WORD "BRAND" INSIDE THE NUMBER "1" THAT BEGINS INSIDE THE INNER CIRCLE AND EXTENDS BEYOND THE INNER AND OUTER CIRCLES; THE NUMBER SIGN NEXT TO THE NUMERICAL "1"; THE WORDS "RECOMMENDED BY VETERINARIANS" IN A RECTANGLE BELOW THE NUMBER "1".
FOR NUTRITIONAL SUPPLEMENTS FOR ANIMALS (U.S. CLS. 6, 18, 44, 46, 51 AND 52).

FIRST USE 3-22-2010; IN COMMERCE 3-22-2010.
ERNEST SHOSHO, EXAMINING ATTORNEY

CLASS 5—(Continued).

SN 85-260,194. THE SUNRIDER CORPORATION, DBA SUNRIDER INTERNATIONAL, TORRANCE, CA. FILED 3-7-2011.

CONCO

THE MARK CONSISTS OF STANDARD CHARACTERS WITHOUT CLAIM TO ANY PARTICULAR FONT, STYLE, SIZE, OR COLOR.

FOR HERBAL NUTRITIONAL SUPPLEMENT FOR HEALTH PURPOSES (U.S. CLS. 6, 18, 44, 46, 51 AND 52).
FIRST USE 7-1-1985; IN COMMERCE 7-1-1985.

ALLISON SCHRODY, EXAMINING ATTORNEY

SN 85-265,228. BACIGALUPI, ANTHONY S., SAN BRUNO, CA. FILED 3-11-2011.

hemp2o

THE MARK CONSISTS OF STANDARD CHARACTERS WITHOUT CLAIM TO ANY PARTICULAR FONT, STYLE, SIZE, OR COLOR.

FOR DIETARY BEVERAGE SUPPLEMENTS FOR HUMAN CONSUMPTION IN LIQUID AND DRY MIX FORM FOR THERAPEUTIC PURPOSES CONTAINING HEMP; DIETARY SUPPLEMENTAL DRINKS IN THE NATURE OF VITAMIN AND MINERAL BEVERAGES CONTAINING HEMP; MINERAL, VITAMIN, OR NUTRITIONALLY ENHANCED WATER CONTAINING HEMP; NUTRITIONALLY FORTIFIED WATER CONTAINING HEMP; VITAMIN ENRICHED WATER CONTAINING HEMP (U.S. CLS. 6, 18, 44, 46, 51 AND 52).

MATTHEW EINSTEIN, EXAMINING ATTORNEY

SN 85-265,824. BEACHBODY, LLC, SANTA MONICA, CA. FILED 3-14-2011.

DELTA DETOX

THE MARK CONSISTS OF STANDARD CHARACTERS WITHOUT CLAIM TO ANY PARTICULAR FONT, STYLE, SIZE, OR COLOR.

NO CLAIM IS MADE TO THE EXCLUSIVE RIGHT TO USE "DETOX", APART FROM THE MARK AS SHOWN.

FOR MEAL REPLACEMENT AND DIETARY SUPPLEMENT DRINKS; POWDERED NUTRITIONAL SUPPLEMENT DRINK MIX; NUTRITIONAL AND DIETARY SUPPLEMENTS; MEAL REPLACEMENT BARS (U.S. CLS. 6, 18, 44, 46, 51 AND 52).

RONALD MCMORROW, EXAMINING ATTORNEY

CLASS 5—(Continued).

SN 85-265,844. BEACHBODY, LLC, SANTA MONICA, CA. FILED 3-14-2011.

DELTA DETOX: THE ULTIMATE
21 DAY RESET

THE MARK CONSISTS OF STANDARD CHARACTERS WITHOUT CLAIM TO ANY PARTICULAR FONT, STYLE, SIZE, OR COLOR.

NO CLAIM IS MADE TO THE EXCLUSIVE RIGHT TO USE "DETOX" AND "21 DAY", APART FROM THE MARK AS SHOWN.

FOR MEAL REPLACEMENT AND DIETARY SUPPLEMENT DRINKS; POWDERED NUTRITIONAL SUPPLEMENT DRINK MIX; NUTRITIONAL AND DIETARY SUPPLEMENTS; MEAL REPLACEMENT BARS (U.S. CLS. 6, 18, 44, 46, 51 AND 52).

RONALD MCMORROW, EXAMINING ATTORNEY

SN 85-267,364. MARTIN, WILLIAM R., DAYTON, OH. FILED 3-15-2011.

MIRAFLOW

THE MARK CONSISTS OF STANDARD CHARACTERS WITHOUT CLAIM TO ANY PARTICULAR FONT, STYLE, SIZE, OR COLOR.

FOR CONTACT LENS CLEANING PREPARATIONS (U.S. CLS. 6, 18, 44, 46, 51 AND 52).

LESLIE RICHARDS, EXAMINING ATTORNEY

SN 85-267,624. NISUS CORPORATION, ROCKFORD, TN. FILED 3-15-2011.

BORA BAIT

OWNER OF U.S. REG. NOS. 1,931,508, 3,006,553 AND 3,276,465.

NO CLAIM IS MADE TO THE EXCLUSIVE RIGHT TO USE "BAIT", APART FROM THE MARK AS SHOWN.

FOR INSECTICIDAL BAIT (U.S. CLS. 6, 18, 44, 46, 51 AND 52).

ANNE MADDEN, EXAMINING ATTORNEY

CLASS 5—(Continued).

SN 85-271,720. KLINGBORG, JON A, ATWATER, CA. FILED 3-20-2011.

The Fleaqualizer

THE MARK CONSISTS OF STANDARD CHARACTERS WITHOUT CLAIM TO ANY PARTICULAR FONT, STYLE, SIZE, OR COLOR.

FOR INSECTICIDES FOR DOMESTIC USE (U.S. CLS. 6, 18, 44, 46, 51 AND 52).

LINDA POWELL, EXAMINING ATTORNEY

SN 85-271,991. HELMS CANDY CO., INC., BRISTOL, VA. FILED 3-21-2011.

Sore Throat Pops

THE MARK CONSISTS OF STANDARD CHARACTERS WITHOUT CLAIM TO ANY PARTICULAR FONT, STYLE, SIZE, OR COLOR.

NO CLAIM IS MADE TO THE EXCLUSIVE RIGHT TO USE "POPS", APART FROM THE MARK AS SHOWN.

SEC. 2(F).

FOR MEDICATED LOLLIPOPS TO TREAT SORE THROATS (U.S. CLS. 6, 18, 44, 46, 51 AND 52).

FIRST USE 1-1-1998; IN COMMERCE 1-1-1998.

REBECCA POVARCHUK, EXAMINING ATTORNEY

SN 85-272,373. LALLEMAND SPECIALTIES, MILWAUKEE, WI. FILED 3-21-2011.

AGRI-CELL

THE MARK CONSISTS OF STANDARD CHARACTERS WITHOUT CLAIM TO ANY PARTICULAR FONT, STYLE, SIZE, OR COLOR.

FOR ANIMAL FEED SUPPLEMENTS, NAMELY, A YEAST BYPRODUCT APPLIED TO FEED TO AID IN THE MICROBIAL BALANCE OF THE DIGESTIVE TRACT (U.S. CLS. 6, 18, 44, 46, 51 AND 52).

FIRST USE 2-24-2011; IN COMMERCE 2-24-2011.

JEFFERY COWARD, EXAMINING ATTORNEY

CLASS 5—(Continued).

SN 85-272,744. HUNZIKER, JOAN C., SAN DIEGO, CA.
FILED 3-21-2011.

BioMatrix Support Adrenals

THE MARK CONSISTS OF STANDARD CHARACTERS WITHOUT CLAIM TO ANY PARTICULAR FONT, STYLE, SIZE, OR COLOR.

OWNER OF U.S. REG. NO. 3,947,743.

NO CLAIM IS MADE TO THE EXCLUSIVE RIGHT TO USE "SUPPORT ADRENALS", APART FROM THE MARK AS SHOWN.

FOR DIETARY AND NUTRITIONAL SUPPLEMENTS (U.S. CLS. 6, 18, 44, 46, 51 AND 52).

FIRST USE 1-14-2000; IN COMMERCE 1-14-2000.

ANNE FARRELL, EXAMINING ATTORNEY

CLASS 5—(Continued).

SN 85-272,765. HUNZIKER, JOAN C., SAN DIEGO, CA.
FILED 3-21-2011.

BioMatrix Support Liver

THE MARK CONSISTS OF STANDARD CHARACTERS WITHOUT CLAIM TO ANY PARTICULAR FONT, STYLE, SIZE, OR COLOR.

OWNER OF U.S. REG. NO. 3,947,743.

NO CLAIM IS MADE TO THE EXCLUSIVE RIGHT TO USE "SUPPORT LIVER", APART FROM THE MARK AS SHOWN.

FOR DIETARY AND NUTRITIONAL SUPPLEMENTS (U.S. CLS. 6, 18, 44, 46, 51 AND 52).

FIRST USE 1-14-2000; IN COMMERCE 1-14-2000.

ANNE FARRELL, EXAMINING ATTORNEY

SN 85-272,753. HUNZIKER, JOAN C., SAN DIEGO, CA.
FILED 3-21-2011.

BioMatrix Support Anti-Ox

THE MARK CONSISTS OF STANDARD CHARACTERS WITHOUT CLAIM TO ANY PARTICULAR FONT, STYLE, SIZE, OR COLOR.

OWNER OF U.S. REG. NO. 3,947,743.

NO CLAIM IS MADE TO THE EXCLUSIVE RIGHT TO USE "SUPPORT", APART FROM THE MARK AS SHOWN.

FOR DIETARY AND NUTRITIONAL SUPPLEMENTS (U.S. CLS. 6, 18, 44, 46, 51 AND 52).

FIRST USE 1-14-2000; IN COMMERCE 1-14-2000.

ANNE FARRELL, EXAMINING ATTORNEY

SN 85-272,769. HUNZIKER, JOAN C., SAN DIEGO, CA.
FILED 3-21-2011.

BioMatrix Support Minerals

THE MARK CONSISTS OF STANDARD CHARACTERS WITHOUT CLAIM TO ANY PARTICULAR FONT, STYLE, SIZE, OR COLOR.

OWNER OF U.S. REG. NO. 3,947,743.

NO CLAIM IS MADE TO THE EXCLUSIVE RIGHT TO USE "SUPPORT MINERALS", APART FROM THE MARK AS SHOWN.

FOR DIETARY AND NUTRITIONAL SUPPLEMENTS (U.S. CLS. 6, 18, 44, 46, 51 AND 52).

FIRST USE 1-14-2000; IN COMMERCE 1-14-2000.

ANNE FARRELL, EXAMINING ATTORNEY

SN 85-272,760. HUNZIKER, JOAN C., SAN DIEGO, CA.
FILED 3-21-2011.

BioMatrix Support Digestion

THE MARK CONSISTS OF STANDARD CHARACTERS WITHOUT CLAIM TO ANY PARTICULAR FONT, STYLE, SIZE, OR COLOR.

OWNER OF U.S. REG. NO. 3,947,743.

NO CLAIM IS MADE TO THE EXCLUSIVE RIGHT TO USE "SUPPORT DIGESTION", APART FROM THE MARK AS SHOWN.

FOR DIETARY AND NUTRITIONAL SUPPLEMENTS (U.S. CLS. 6, 18, 44, 46, 51 AND 52).

FIRST USE 1-14-2000; IN COMMERCE 1-14-2000.

ANNE FARRELL, EXAMINING ATTORNEY

SN 85-272,776. HUNZIKER, JOAN C., SAN DIEGO, CA.
FILED 3-21-2011.

BioMatrix DHEA

THE MARK CONSISTS OF STANDARD CHARACTERS WITHOUT CLAIM TO ANY PARTICULAR FONT, STYLE, SIZE, OR COLOR.

OWNER OF U.S. REG. NO. 3,947,743.

NO CLAIM IS MADE TO THE EXCLUSIVE RIGHT TO USE "DHEA", APART FROM THE MARK AS SHOWN.

FOR DIETARY AND NUTRITIONAL SUPPLEMENTS CONTAINING DHEA; HORMONE REPLACEMENT THERAPY PREPARATIONS CONTAINING DHEA (U.S. CLS. 6, 18, 44, 46, 51 AND 52).

FIRST USE 1-14-2000; IN COMMERCE 1-14-2000.

ANNE FARRELL, EXAMINING ATTORNEY

CLASS 5—(Continued).

SN 85-272,778. HUNZIKER, JOAN C., SAN DIEGO, CA.
FILED 3-21-2011.

BioMatrix Pregnenolone

THE MARK CONSISTS OF STANDARD CHARACTERS
WITHOUT CLAIM TO ANY PARTICULAR FONT, STYLE,
SIZE, OR COLOR.

OWNER OF U.S. REG. NO. 3,947,743.

NO CLAIM IS MADE TO THE EXCLUSIVE RIGHT TO
USE "PREGNENOLONE", APART FROM THE MARK AS
SHOWN.

FOR DIETARY AND NUTRITIONAL SUPPLEMENTS
CONTAINING PREGNENOLONE; HORMONE REPLA-
CEMENT THERAPY PREPARATIONS CONTAINING
PREGNENOLONE (U.S. CLS. 6, 18, 44, 46, 51 AND 52).

FIRST USE 1-14-2000; IN COMMERCE 1-14-2000.

ANNE FARRELL, EXAMINING ATTORNEY

SN 85-272,783. HUNZIKER, JOAN C., SAN DIEGO, CA.
FILED 3-21-2011.

**BioMatrix Licorice Root
Extract**

THE MARK CONSISTS OF STANDARD CHARACTERS
WITHOUT CLAIM TO ANY PARTICULAR FONT, STYLE,
SIZE, OR COLOR.

OWNER OF U.S. REG. NO. 3,947,743.

NO CLAIM IS MADE TO THE EXCLUSIVE RIGHT TO
USE "LICORICE ROOT EXTRACT", APART FROM THE
MARK AS SHOWN.

FOR DIETARY AND NUTRITIONAL SUPPLEMENTS
CONTAINING LICORICE ROOT EXTRACT (U.S. CLS. 6,
18, 44, 46, 51 AND 52).

FIRST USE 1-14-2000; IN COMMERCE 1-14-2000.

ANNE FARRELL, EXAMINING ATTORNEY

SN 85-272,786. HUNZIKER, JOAN C., SAN DIEGO, CA.
FILED 3-21-2011.

BioMatrix Support Mucosa

THE MARK CONSISTS OF STANDARD CHARACTERS
WITHOUT CLAIM TO ANY PARTICULAR FONT, STYLE,
SIZE, OR COLOR.

OWNER OF U.S. REG. NO. 3,947,743.

NO CLAIM IS MADE TO THE EXCLUSIVE RIGHT TO
USE "SUPPORT MUCOSA", APART FROM THE MARK AS
SHOWN.

FOR DIETARY AND NUTRITIONAL SUPPLEMENTS
(U.S. CLS. 6, 18, 44, 46, 51 AND 52).

FIRST USE 1-14-2000; IN COMMERCE 1-14-2000.

ANNE FARRELL, EXAMINING ATTORNEY

CLASS 5—(Continued).

SN 85-272,791. HUNZIKER, JOAN C., SAN DIEGO, CA.
FILED 3-21-2011.

BioMatrix Pro-Adapt

THE MARK CONSISTS OF STANDARD CHARACTERS
WITHOUT CLAIM TO ANY PARTICULAR FONT, STYLE,
SIZE, OR COLOR.

OWNER OF U.S. REG. NO. 3,947,743.

FOR DIETARY AND NUTRITIONAL SUPPLEMENTS;
HORMONE REPLACEMENT THERAPY PREPARA-
TIONS (U.S. CLS. 6, 18, 44, 46, 51 AND 52).

FIRST USE 1-14-2000; IN COMMERCE 1-14-2000.

ANNE FARRELL, EXAMINING ATTORNEY

SN 85-273,229. JIM YEUNG, GILROY, CA. FILED 3-22-2011.

AIRPRO

THE MARK CONSISTS OF STANDARD CHARACTERS
WITHOUT CLAIM TO ANY PARTICULAR FONT, STYLE,
SIZE, OR COLOR.

FOR AIR FRESHENER (U.S. CLS. 6, 18, 44, 46, 51 AND
52).

FIRST USE 2-10-2011; IN COMMERCE 2-10-2011.

ASMAT KHAN, EXAMINING ATTORNEY

CLASS 5—(Continued).

SN 85-273,331. MOLECULAR THERAPEUTICS, ATHENS, GA. FILED 3-22-2011.

Neocide-3

THE MARK CONSISTS OF STANDARD CHARACTERS WITHOUT CLAIM TO ANY PARTICULAR FONT, STYLE, SIZE, OR COLOR.

FOR ANTIBACTERIAL PHARMACEUTICALS FOR VETERINARY USE; ANTIBACTERIAL SUBSTANCES FOR VETERINARY USE; DERMATOLOGICAL PHARMACEUTICAL PRODUCTS FOR VETERINARY USE; PHARMACEUTICAL PREPARATIONS AND SUBSTANCES FOR VETERINARY USE FOR THE TREATMENT OF DAMAGED SKIN AND TISSUE; PHARMACEUTICAL PREPARATIONS AND SUBSTANCES FOR VETERINARY USE FOR THE TREATMENT OF INFECTIOUS DISEASES, BLOOD DISORDERS, PAIN, INFLAMMATION, SEPSIS, ALOPECIA, OBESITY AND COGNITIVE DISORDERS; PHARMACEUTICAL PREPARATIONS FOR VETERINARY USE FOR THE TREATMENT OF INFECTIOUS DISEASES; PHARMACEUTICAL PREPARATIONS FOR VETERINARY USE FOR THE TREATMENT OF SKIN LESIONS; PHARMACEUTICAL PREPARATIONS FOR VETERINARY USE IN DERMATOLOGY; PHARMACEUTICAL PREPARATIONS FOR VETERINARY USE FOR WOUNDS; PHARMACEUTICALS, NAMELY, ANTI-INFECTIVES FOR VETERINARY USE; THERAPEUTIC PHARMACEUTICAL FOR VETERINARY USE FOR THE TREATMENT OF SKIN LESIONS (U.S. CLS. 6, 18, 44, 46, 51 AND 52).

FIRST USE 12-1-2002; IN COMMERCE 1-1-2003.
REBECCA EISINGER, EXAMINING ATTORNEY

SN 85-273,695. AGRARIAN MARKETING CORPORATION, MIDDLEBURY, IN. FILED 3-22-2011.

AGRARIAN MARKETING CORPORATION

THE MARK CONSISTS OF STANDARD CHARACTERS WITHOUT CLAIM TO ANY PARTICULAR FONT, STYLE, SIZE, OR COLOR.

OWNER OF U.S. REG. NO. 2,937,074.
NO CLAIM IS MADE TO THE EXCLUSIVE RIGHT TO USE "CORPORATION", APART FROM THE MARK AS SHOWN.

SEC. 2(F).
FOR NUTRITIONAL SUPPLEMENTS FOR LIVESTOCK; LIVESTOCK SILAGE AND HAYLAGE SUPPLEMENTS (U.S. CLS. 6, 18, 44, 46, 51 AND 52).

FIRST USE 6-30-1996; IN COMMERCE 6-30-1996.
REBECCA GILBERT, EXAMINING ATTORNEY

CLASS 5—(Continued).

SN 85-274,291. GREAT AMERICAN PRODUCTS, INC., DESTIN, FL. FILED 3-23-2011.

MASTER PROSTATE

THE MARK CONSISTS OF STANDARD CHARACTERS WITHOUT CLAIM TO ANY PARTICULAR FONT, STYLE, SIZE, OR COLOR.

OWNER OF U.S. REG. NOS. 3,043,809, 3,443,339 AND OTHERS.

NO CLAIM IS MADE TO THE EXCLUSIVE RIGHT TO USE "PROSTATE", APART FROM THE MARK AS SHOWN.

FOR DIETARY SUPPLEMENTS (U.S. CLS. 6, 18, 44, 46, 51 AND 52).

JOHN DWYER, EXAMINING ATTORNEY

SN 85-274,309. CHRISTOPHER WARREN, SEDONA, AZ. FILED 3-23-2011.



THE COLOR(S) BLACK, YELLOW, AND WHITE IS/ARE CLAIMED AS A FEATURE OF THE MARK.

THE MARK CONSISTS OF THE STYLIZED TEXT "AZ" IN YELLOW, THE TEXT "ENERGETICS" IN WHITE, AND YELLOW HORIZONTAL BARS EXTENDING TO THE RIGHT AND TO THE LEFT, ALL ON A BLACK BACKGROUND.

FOR DIETARY AND NUTRITIONAL SUPPLEMENTS (U.S. CLS. 6, 18, 44, 46, 51 AND 52).

JEAN IM, EXAMINING ATTORNEY

SN 85-274,400. BEAUMONT PRODUCTS, INC., KENNESAW, GA. FILED 3-23-2011.

FOCUS ON A FLASH

THE MARK CONSISTS OF STANDARD CHARACTERS WITHOUT CLAIM TO ANY PARTICULAR FONT, STYLE, SIZE, OR COLOR.

NO CLAIM IS MADE TO THE EXCLUSIVE RIGHT TO USE "FLASH", APART FROM THE MARK AS SHOWN.

FOR HOT FLASH SPRAY TOPICAL TREATMENT (U.S. CLS. 6, 18, 44, 46, 51 AND 52).

CYNTHIA SLOAN, EXAMINING ATTORNEY

CLASS 5—(Continued).

SN 85-274,460. GLUTEN FREE BAKE SHOP, INC., DBA KATZ GLUTEN FREE, MONROE, NY. FILED 3-23-2011.

KATZ GLUTEN FREE

THE MARK CONSISTS OF STANDARD CHARACTERS WITHOUT CLAIM TO ANY PARTICULAR FONT, STYLE, SIZE, OR COLOR.

OWNER OF U.S. REG. NOS. 3,878,911 AND 3,976,428.

NO CLAIM IS MADE TO THE EXCLUSIVE RIGHT TO USE "GLUTEN FREE", APART FROM THE MARK AS SHOWN.

SEC. 2(F) AS TO "KATZ".

FOR BAKERY GOODS, BREADS, ROLLS, CHALLAH, PIZZA CRUSTS, BAKERY DESSERTS, CAKES, COOKIES, MUFFINS, CUP CAKES, PASTRIES, RUGELACH, BREAD CRUMBS, NOODLES, AND PREPARED DIETARY ITEMS, ALL OF WHICH ARE GLUTEN-FREE TO ACCOMMODATE SPECIAL MEDICAL AND HEALTH CONDITIONS; GLUTEN-FREE FOOD TO ACCOMMODATE SPECIAL MEDICAL AND HEALTH CONDITIONS (U.S. CLS. 6, 18, 44, 46, 51 AND 52).

FIRST USE 1-0-2006; IN COMMERCE 1-0-2006.

JAY FLOWERS, EXAMINING ATTORNEY

SN 85-276,934. AMRION NUTRACEUTICALS LLC, BOULDER, CO. FILED 3-25-2011.

ADVANCED EFA ARRAY

THE MARK CONSISTS OF STANDARD CHARACTERS WITHOUT CLAIM TO ANY PARTICULAR FONT, STYLE, SIZE, OR COLOR.

NO CLAIM IS MADE TO THE EXCLUSIVE RIGHT TO USE "EFA", APART FROM THE MARK AS SHOWN.

FOR DIETARY AND NUTRITIONAL SUPPLEMENTS COMPRISED IN SUBSTANTIAL PART OF ESSENTIAL FATTY ACIDS (U.S. CLS. 6, 18, 44, 46, 51 AND 52).

SKYE YOUNG, EXAMINING ATTORNEY

SN 85-277,362. BIOPLEX NUTRITION, INC., BLAINE, WA. FILED 3-25-2011.

S LINE

THE MARK CONSISTS OF STANDARD CHARACTERS WITHOUT CLAIM TO ANY PARTICULAR FONT, STYLE, SIZE, OR COLOR.

NO CLAIM IS MADE TO THE EXCLUSIVE RIGHT TO USE "LINE", APART FROM THE MARK AS SHOWN.

FOR DIETARY AND NUTRITIONAL SUPPLEMENTS (U.S. CLS. 6, 18, 44, 46, 51 AND 52).

GEOFFREY FOSDICK, EXAMINING ATTORNEY

CLASS 5—(Continued).

SN 85-277,811. GENETHIX, SAINT. CHARLES, MO. FILED 3-26-2011.



THE MARK CONSISTS OF THE STYLIZED WORDING "GENETHIX DELIVERS TOMORROW'S CHAMPIONS", WITH AN IMAGE OF A FIGURE INSIDE A CIRCLE ABOVE THE TEXT.

FOR DIETARY SUPPLEMENTS (U.S. CLS. 6, 18, 44, 46, 51 AND 52).

FIRST USE 8-10-2010; IN COMMERCE 8-19-2010.

KIMBERLY FRYE, EXAMINING ATTORNEY

SN 85-278,213. NATREN, INC., WESTLAKE VILLAGE, CA. FILED 3-28-2011.

ANIMALIA MICROBIALS

THE MARK CONSISTS OF STANDARD CHARACTERS WITHOUT CLAIM TO ANY PARTICULAR FONT, STYLE, SIZE, OR COLOR.

NO CLAIM IS MADE TO THE EXCLUSIVE RIGHT TO USE "MICROBIALS", APART FROM THE MARK AS SHOWN.

FOR DIETARY SUPPLEMENTS FOR ANIMALS CONTAINING MICROBIALS (U.S. CLS. 6, 18, 44, 46, 51 AND 52).

JILL C. ALT, EXAMINING ATTORNEY

SN 85-278,488. MANCHESTER PHARMACEUTICALS, INC., MOUNTAIN VIEW, CA. FILED 3-28-2011.

VECAMYL

THE MARK CONSISTS OF STANDARD CHARACTERS WITHOUT CLAIM TO ANY PARTICULAR FONT, STYLE, SIZE, OR COLOR.

FOR PHARMACEUTICAL PREPARATIONS FOR THE TREATMENT OF CARDIOVASCULAR, NEUROLOGICAL AND PSYCHIATRIC DISORDERS (U.S. CLS. 6, 18, 44, 46, 51 AND 52).

KEVIN CORWIN, EXAMINING ATTORNEY

CLASS 5—(Continued).

SN 85-278,519. MANCHESTER PHARMACEUTICALS, INC., MOUNTAIN VIEW, CA. FILED 3-28-2011.

VERCAL

THE MARK CONSISTS OF STANDARD CHARACTERS WITHOUT CLAIM TO ANY PARTICULAR FONT, STYLE, SIZE, OR COLOR.

FOR PHARMACEUTICAL PREPARATIONS FOR THE TREATMENT OF CARDIOVASCULAR, NEUROLOGICAL AND PSYCHIATRIC DISORDERS (U.S. CLS. 6, 18, 44, 46, 51 AND 52).

KEVIN CORWIN, EXAMINING ATTORNEY

CLASS 5—(Continued).

SN 85-287,104. MEDICAL RESEARCH INSTITUTE, CHATSWORTH, CA. FILED 4-5-2011.

HEMO-SURGE

THE MARK CONSISTS OF STANDARD CHARACTERS WITHOUT CLAIM TO ANY PARTICULAR FONT, STYLE, SIZE, OR COLOR.

FOR DIETARY SUPPLEMENTS (U.S. CLS. 6, 18, 44, 46, 51 AND 52).

LEIGH LOWRY, EXAMINING ATTORNEY

SN 85-286,545. BAYER AKTIENGESELLSCHAFT, LEVERKUSEN, FED REP GERMANY, FILED 4-5-2011.



THE COLOR(S) LAVENDER, GREEN, TEAL AND GRAY IS/ARE CLAIMED AS A FEATURE OF THE MARK.

THE MARK CONSISTS OF A DESIGN OF THREE STYLIZED OVALS AND ONE PARTIAL OVAL, IN CLOSE PROXIMITY TO ONE ANOTHER, POSITIONED AT APPROXIMATELY 45 DEGREE ANGLES TO ONE ANOTHER. THE TOP OVAL IS TEAL IN COLOR, THE LEFT AND RIGHT OVALS ARE RESPECTIVELY LAVENDER AND GREEN IN COLOR, AND THE BOTTOM PARTIAL OVAL IS IN VARIOUS SHADES OF GRAY. THE COLOR WHITE REPRESENTS BACKGROUND OR TRANSPARENT AREAS AND IS NOT A FEATURE OF THE MARK.

FOR PHARMACEUTICAL PREPARATIONS, NAMELY, HORMONAL PREPARATIONS (U.S. CLS. 6, 18, 44, 46, 51 AND 52).

JENNIFER MARTIN, EXAMINING ATTORNEY

SN 85-287,302. COUNTRY MOUSE LLC, CHARLOTTE, VT. FILED 4-6-2011.

APGAR BAR

THE MARK CONSISTS OF STANDARD CHARACTERS WITHOUT CLAIM TO ANY PARTICULAR FONT, STYLE, SIZE, OR COLOR.

NO CLAIM IS MADE TO THE EXCLUSIVE RIGHT TO USE "BAR", APART FROM THE MARK AS SHOWN.

FOR BABY FOOD; BABY FOODS; BISCUITS, BREAD, BREAD ROLLS, CAKES, CEREAL PRODUCTS, CONFECTIONERY, CRACKERS, NOODLES, FISH SAUCE, RELISH, SAUCES, CEREAL-BASED SNACK-FOODS AND PREPARED DIETARY ITEMS ALL OF WHICH ARE GLUTEN -FREE TO ACCOMMODATE SPECIAL MEDICAL AND HEALTH CONDITIONS; DIETARY AND NUTRITIONAL SUPPLEMENTS; DIETARY FOOD SUPPLEMENTS; DIETARY SUPPLEMENTS; FOOD FOR BABIES; FOOD FOR INFANTS; FOOD FOR MEDICALLY RESTRICTED DIETS; FOOD SUPPLEMENTS; FOODS FOR INDIVIDUALS WITH SPECIAL DIETARY REQUIREMENTS NECESSITATED BY MEDICAL TREATMENTS; GLUTEN-FREE FOOD TO ACCOMMODATE SPECIAL MEDICAL AND HEALTH CONDITIONS; MEAL REPLACEMENT BARS; MEAL REPLACEMENT SNACKS; MINERAL FOOD SUPPLEMENTS; MINERAL NUTRITIONAL SUPPLEMENTS; NUTRACEUTICALS FOR USE AS A DIETARY SUPPLEMENT; NUTRITIONAL ENERGY BARS FOR USE AS A MEAL SUBSTITUTE; NUTRITIONAL MEAL REPLACEMENT BARS FOR INDIVIDUALS UNDERGOING MEDICAL TREATMENTS; NUTRITIONAL SUPPLEMENTS; PROTEIN SUPPLEMENTS; VITAMIN AND MINERAL FORMED AND PACKAGED AS BARS; VITAMIN AND MINERAL SUPPLEMENTS (U.S. CLS. 6, 18, 44, 46, 51 AND 52).

LAURA KOVALSKY, EXAMINING ATTORNEY

CLASS 5—(Continued).

SN 85-288,241. AMERICAN COSMETICS & PHARMACEUTICAL LLC, LADER RANCH, CA. FILED 4-6-2011.



THE COLOR(S) BLACK, SILVER AND PINK IS/ARE CLAIMED AS A FEATURE OF THE MARK.

THE MARK CONSISTS OF THE STYLIZED WORD "FOKUS". THE LETTERS "F" AND "KUS" ARE IN BLACK. THE LETTER "O" IS REPRESENTED BY A SILVER POWER BUTTON WITH A PINK BRAIN IN THE MIDDLE. THE STYLIZED PHRASE "POWER YOUR BRAIN" IS BELOW IN BLACK. WHITE IS MERELY THE BACKGROUND COLOR AND IS NOT CLAIMED AS A FEATURE OF THE MARK.

FOR DIETARY SUPPLEMENTAL DRINKS; DIETARY SUPPLEMENTAL DRINKS IN THE NATURE OF VITAMIN AND MINERAL BEVERAGES (U.S. CLS. 6, 18, 44, 46, 51 AND 52).

KELLY BOULTON, EXAMINING ATTORNEY

CLASS 5—(Continued).

SN 85-288,850. AMERIFIT, INC., CROMWELL, CT. FILED 4-7-2011.

AZO PMS

THE MARK CONSISTS OF STANDARD CHARACTERS WITHOUT CLAIM TO ANY PARTICULAR FONT, STYLE, SIZE, OR COLOR.

OWNER OF U.S. REG. NOS. 2,349,020, 3,070,332 AND OTHERS.

NO CLAIM IS MADE TO THE EXCLUSIVE RIGHT TO USE "PMS", APART FROM THE MARK AS SHOWN.

FOR DIETARY AND NUTRITIONAL SUPPLEMENTS; DIETARY AND NUTRITIONAL SUPPLEMENTS FOR THE TREATMENT OF PREMENSTRUAL SYNDROME (U.S. CLS. 6, 18, 44, 46, 51 AND 52).

FIRST USE 2-0-2011; IN COMMERCE 2-0-2011.

LEIGH CAROLINE CASE, EXAMINING ATTORNEY

SN 85-289,549. SORENSEN, REVEREND JUDI, PAHRUMP, NV. FILED 4-7-2011.



THE MARK CONSISTS OF MOUNTAINS ABOVE THE WORDS OF THE MARK "WINTERCREST".

FOR ANALGESIC BALM; BALMS FOR MEDICAL PURPOSES; BALMS FOR PHARMACEUTICAL PURPOSES; HERBAL TOPICAL CREAMS, GELS, SALVES, SPRAYS, POWDER, BALMS, LINIMENT AND OINTMENTS FOR THE RELIEF OF ACHE AND PAIN; MEDICATED BALMS FOR TREATMENT OF SKIN; MEDICATED LIP BALM (U.S. CLS. 6, 18, 44, 46, 51 AND 52).

FIRST USE 8-31-1999; IN COMMERCE 8-31-1999.

ANDREA K. NADELMAN, EXAMINING ATTORNEY

SN 85-288,644. GAMMA ENTERPRISES, LLC, WEST BABYLON, NY. FILED 4-7-2011.



THE MARK CONSISTS OF THREE CRESCENTS FORMED AROUND AN INNER CIRCLE, IN THE IMAGE OF A ROTARY OR TURBINE ENGINE.

FOR DIETARY AND NUTRITIONAL SUPPLEMENTS (U.S. CLS. 6, 18, 44, 46, 51 AND 52).

FIRST USE 3-0-2009; IN COMMERCE 3-0-2009.

JOSETTE BEVERLY, EXAMINING ATTORNEY

SN 85-290,169. CUTTING EDGE BEVERAGES, LLC, BOCA RATON, FL. FILED 4-8-2011.

vitamin H₂Organics

OWNER OF U.S. REG. NO. 3,513,779.

NO CLAIM IS MADE TO THE EXCLUSIVE RIGHT TO USE "VITAMIN", APART FROM THE MARK AS SHOWN.

THE MARK CONSISTS OF THE WORD "VITAMIN" ON THE FIRST LINE AND THE WORD "H₂ORGANICS" ON THE SECOND LINE, BOTH IN STYLIZED FONT.

FOR ORGANIC NUTRITIONALLY FORTIFIED WATER, NAMELY, FLAVORED WATER ENHANCED WITH VITAMINS, MINERALS, ANTIOXIDANTS AND NUTRACEUTICALS (U.S. CLS. 6, 18, 44, 46, 51 AND 52).

LINDA ORNDORFF, EXAMINING ATTORNEY

CLASS 5—(Continued).

SN 85-290,802. NEILMED PRODUCTS, INC., SANTA ROSA, CA. FILED 4-8-2011.

SALINE ON THE GO

THE MARK CONSISTS OF STANDARD CHARACTERS WITHOUT CLAIM TO ANY PARTICULAR FONT, STYLE, SIZE, OR COLOR.

NO CLAIM IS MADE TO THE EXCLUSIVE RIGHT TO USE "SALINE", APART FROM THE MARK AS SHOWN.

FOR PHARMACEUTICAL PREPARATIONS FOR THE TREATMENT OF NASAL AND SINUS AILMENTS (U.S. CLS. 6, 18, 44, 46, 51 AND 52).

FIRST USE 3-24-2011; IN COMMERCE 3-24-2011.
ALYSSA STEEL, EXAMINING ATTORNEY

SN 85-290,808. NEILMED PRODUCTS, INC., SANTA ROSA, CA. FILED 4-8-2011.

CLEARCANAL

THE MARK CONSISTS OF STANDARD CHARACTERS WITHOUT CLAIM TO ANY PARTICULAR FONT, STYLE, SIZE, OR COLOR.

FOR PHARMACEUTICAL PREPARATIONS FOR THE TREATMENT OF EAR AILMENTS (U.S. CLS. 6, 18, 44, 46, 51 AND 52).

ALYSSA STEEL, EXAMINING ATTORNEY

SN 85-291,189. MEDCHEM MANUFACTURING, INC., TORRANCE, CA. FILED 4-10-2011.

XOTEN

THE MARK CONSISTS OF STANDARD CHARACTERS WITHOUT CLAIM TO ANY PARTICULAR FONT, STYLE, SIZE, OR COLOR.

FOR MEDICINAL CREAMS FOR SKIN CARE; PAIN RELIEF MEDICATION; TOPICAL GEL FOR MEDICAL AND THERAPEUTIC TREATMENT OF INFLAMMATION AND PAIN (U.S. CLS. 6, 18, 44, 46, 51 AND 52).

FIRST USE 4-4-2011; IN COMMERCE 4-4-2011.
ANGELA DUONG, EXAMINING ATTORNEY

CLASS 5—(Continued).

SN 85-291,469. VICAR OPERATING, INC., LOS ANGELES, CA. FILED 4-11-2011.

ARTHROGUARD

THE MARK CONSISTS OF STANDARD CHARACTERS WITHOUT CLAIM TO ANY PARTICULAR FONT, STYLE, SIZE, OR COLOR.

FOR VETERINARY PREPARATIONS FOR OSTEOARTHRITIS IN DOGS AND CATS (U.S. CLS. 6, 18, 44, 46, 51 AND 52).

JUDITH HELFMAN, EXAMINING ATTORNEY

SN 85-291,482. VICAR OPERATING, INC., LOS ANGELES, CA. FILED 4-11-2011.

COMFORTGUARD

THE MARK CONSISTS OF STANDARD CHARACTERS WITHOUT CLAIM TO ANY PARTICULAR FONT, STYLE, SIZE, OR COLOR.

FOR VETERINARY PREPARATIONS FOR OSTEOARTHRITIS IN DOGS AND CATS (U.S. CLS. 6, 18, 44, 46, 51 AND 52).

JUDITH HELFMAN, EXAMINING ATTORNEY

SN 85-291,487. NEW WORLD IMPORTS, NASHVILLE, TN. FILED 4-11-2011.



THE COLOR(S) WHITE, BLACK, AND BLUE IS/ARE CLAIMED AS A FEATURE OF THE MARK.

THE MARK CONSISTS OF THE WORDING "CAREALL" AND ASSOCIATED DESIGN ELEMENTS. THE WORDING "CAREALL" APPEARS AS ONE COMPOUND WORD, WITH "CARE" IN THE COLOR BLACK AND "ALL" IN THE COLOR BLUE. THE DESIGN IS LOCATED TO THE LEFT OF THE WORDING AND CONSISTS OF A WHITE SQUARE WITH BLACK DOTS AROUND ITS PERIMETER, WITH WHITE AND BLUE DOTS EXTENDING FROM THE WHITE SQUARE BOTH HORIZONTALLY AND VERTICALLY TO CREATE A CROSS WITH EQUAL SIZED LINES, WITHIN A BLUE SHADED SQUARE WITH SLIGHTLY CURVED EDGES.

FOR ACETAMINOPHEN; ANTIBIOTIC CREAMS; ANTIBIOTIC OINTMENTS; ANTIFUNGAL CREAMS FOR MEDICAL USE; ARTIFICIAL TEARS; ASPIRIN; HYDROCORTISONE CREAM; IBUPROFEN FOR USE AS AN ORAL ANALGESIC; MUSCLE RELAXANTS (U.S. CLS. 6, 18, 44, 46, 51 AND 52).

JUDITH HELFMAN, EXAMINING ATTORNEY

CLASS 5—(Continued).

SN 85-291,519. MINNEAMRITA THERAPEUTICS LLC, MO-
LINE, IL. FILED 4-11-2011.

ENRICHING HEALTH,
ENHANCING LIFE

THE MARK CONSISTS OF STANDARD CHARACTERS
WITHOUT CLAIM TO ANY PARTICULAR FONT, STYLE,
SIZE, OR COLOR.
FOR PHARMACEUTICALS, NAMELY, PHARMACEU-
TICALS FOR THE TREATMENT OF CANCER (U.S. CLS.
6, 18, 44, 46, 51 AND 52).
MARY CRAWFORD, EXAMINING ATTORNEY

SN 85-291,531. MINNEAMRITA THERAPEUTICS LLC, MO-
LINE, IL. FILED 4-11-2011.

MINNELIDE

THE MARK CONSISTS OF STANDARD CHARACTERS
WITHOUT CLAIM TO ANY PARTICULAR FONT, STYLE,
SIZE, OR COLOR.
FOR PHARMACEUTICALS, NAMELY, PHARMACEU-
TICALS FOR THE TREATMENT OF CANCER (U.S. CLS.
6, 18, 44, 46, 51 AND 52).
MARY CRAWFORD, EXAMINING ATTORNEY

SN 85-291,549. E5 LLC, HONOLULU, HI. FILED 4-11-2011.

PROHORMETIC

THE MARK CONSISTS OF STANDARD CHARACTERS
WITHOUT CLAIM TO ANY PARTICULAR FONT, STYLE,
SIZE, OR COLOR.
FOR DIETARY AND NUTRITIONAL SUPPLEMENTS
(U.S. CLS. 6, 18, 44, 46, 51 AND 52).
KELLY BOULTON, EXAMINING ATTORNEY

CLASS 5—(Continued).

SN 85-291,558. KOLOS, EDWARD, STUART, FL. FILED 4-11-
2011.

Aquatat

THE MARK CONSISTS OF STANDARD CHARACTERS
WITHOUT CLAIM TO ANY PARTICULAR FONT, STYLE,
SIZE, OR COLOR.
FOR MEDICINAL CREAMS FOR SKIN CARE (U.S.
CLS. 6, 18, 44, 46, 51 AND 52).
EDWARD NELSON, EXAMINING ATTORNEY

SN 85-291,579. CAREFUSION 2200, INC., SAN DIEGO, CA.
FILED 4-11-2011.

ChloraPrep

OWNER OF U.S. REG. NO. 1,930,248.
THE MARK CONSISTS OF STYLIZED TEXT OF THE
WORD "CHLORAPREP" WITH A CAPITAL "C" AND A
CAPITAL "P".
FOR BROAD-SPECTRUM ANTISEPTIC (U.S. CLS. 6,
18, 44, 46, 51 AND 52).
FIRST USE 6-7-1994; IN COMMERCE 6-7-1994.
ROSELLE HERRERA, EXAMINING ATTORNEY

SN 85-291,730. AVEO PHARMACEUTICALS, INC., CAM-
BRIDGE, MA. FILED 4-11-2011.

VEGCAN

THE MARK CONSISTS OF STANDARD CHARACTERS
WITHOUT CLAIM TO ANY PARTICULAR FONT, STYLE,
SIZE, OR COLOR.
FOR PHARMACEUTICAL PRODUCTS FOR THE PRE-
VENTION AND TREATMENT OF CANCER (U.S. CLS. 6,
18, 44, 46, 51 AND 52).
CHRISTINE MARTIN, EXAMINING ATTORNEY

CLASS 5—(Continued).

SN 85-291,751. RFI, LLC, BLAUVELT, NY. FILED 4-11-2011.

FermaPro

THE MARK CONSISTS OF STANDARD CHARACTERS WITHOUT CLAIM TO ANY PARTICULAR FONT, STYLE, SIZE, OR COLOR.
FOR DIETARY AND NUTRITIONAL SUPPLEMENTS; DIETARY FOOD SUPPLEMENTS; DIETARY SUPPLEMENTAL DRINKS; FOOD SUPPLEMENTS; HERBAL SUPPLEMENTS (U.S. CLS. 6, 18, 44, 46, 51 AND 52).
FIRST USE 4-1-2011; IN COMMERCE 4-1-2011.
ASMAT KHAN, EXAMINING ATTORNEY

CLASS 5—(Continued).

SN 85-291,793. L.O.D.C., INC., DENTON, TX. FILED 4-11-2011.

FunctionALOE

THE MARK CONSISTS OF STANDARD CHARACTERS WITHOUT CLAIM TO ANY PARTICULAR FONT, STYLE, SIZE, OR COLOR.
FOR DIETARY AND NUTRITIONAL SUPPLEMENTS CONTAINING ALOE VERA (U.S. CLS. 6, 18, 44, 46, 51 AND 52).
FIRST USE 3-15-2010; IN COMMERCE 3-15-2010.
CHRISTINE MARTIN, EXAMINING ATTORNEY

SN 85-291,758. AVEO PHARMACEUTICALS, INC., CAMBRIDGE, MA. FILED 4-11-2011.

ZANIB

THE MARK CONSISTS OF STANDARD CHARACTERS WITHOUT CLAIM TO ANY PARTICULAR FONT, STYLE, SIZE, OR COLOR.
FOR PHARMACEUTICAL PRODUCTS FOR THE PREVENTION AND TREATMENT OF CANCER (U.S. CLS. 6, 18, 44, 46, 51 AND 52).
CHRISTINE MARTIN, EXAMINING ATTORNEY

SN 85-291,804. AVEO PHARMACEUTICALS, INC., CAMBRIDGE, MA. FILED 4-11-2011.

SELTIVO

THE MARK CONSISTS OF STANDARD CHARACTERS WITHOUT CLAIM TO ANY PARTICULAR FONT, STYLE, SIZE, OR COLOR.
FOR PHARMACEUTICAL PRODUCTS FOR THE PREVENTION AND TREATMENT OF CANCER (U.S. CLS. 6, 18, 44, 46, 51 AND 52).
CHRISTINE MARTIN, EXAMINING ATTORNEY

SN 85-291,786. AVEO PHARMACEUTICALS, INC., CAMBRIDGE, MA. FILED 4-11-2011.

TIVOZIB

THE MARK CONSISTS OF STANDARD CHARACTERS WITHOUT CLAIM TO ANY PARTICULAR FONT, STYLE, SIZE, OR COLOR.
FOR PHARMACEUTICAL PRODUCTS FOR THE PREVENTION AND TREATMENT OF CANCER (U.S. CLS. 6, 18, 44, 46, 51 AND 52).
CHRISTINE MARTIN, EXAMINING ATTORNEY

SN 85-291,824. AVEO PHARMACEUTICALS, INC., CAMBRIDGE, MA. FILED 4-11-2011.

SELTIVOS

THE MARK CONSISTS OF STANDARD CHARACTERS WITHOUT CLAIM TO ANY PARTICULAR FONT, STYLE, SIZE, OR COLOR.
FOR PHARMACEUTICAL PRODUCTS FOR THE PREVENTION AND TREATMENT OF CANCER (U.S. CLS. 6, 18, 44, 46, 51 AND 52).
CHRISTINE MARTIN, EXAMINING ATTORNEY

CLASS 5—(Continued).

SN 85-291,838. L.O.D.C., INC., DENTON, TX. FILED 4-11-2011.

Gluc-aloe

THE MARK CONSISTS OF STANDARD CHARACTERS WITHOUT CLAIM TO ANY PARTICULAR FONT, STYLE, SIZE, OR COLOR.

FOR DIETARY AND NUTRITIONAL SUPPLEMENTS CONTAINING ALOE VERA (U.S. CLS. 6, 18, 44, 46, 51 AND 52).

FIRST USE 3-15-2010; IN COMMERCE 3-15-2010.
CHRISTINE MARTIN, EXAMINING ATTORNEY

SN 85-291,853. VELOX PRODUCTS, LLC, WESTON, FL. FILED 4-11-2011.

Velox

THE MARK CONSISTS OF STANDARD CHARACTERS WITHOUT CLAIM TO ANY PARTICULAR FONT, STYLE, SIZE, OR COLOR.

FOR DIETARY AND NUTRITIONAL SUPPLEMENTS (U.S. CLS. 6, 18, 44, 46, 51 AND 52).
CAROLINE WOOD, EXAMINING ATTORNEY

SN 85-291,888. MAP PHARMACEUTICALS, INC., MOUNTAIN VIEW, CA. FILED 4-11-2011.

SEMPRANA

THE MARK CONSISTS OF STANDARD CHARACTERS WITHOUT CLAIM TO ANY PARTICULAR FONT, STYLE, SIZE, OR COLOR.

FOR INHALED PHARMACEUTICAL PREPARATIONS FOR THE TREATMENT OF RESPIRATORY DISEASES AND DISORDERS; DRUG DELIVERY DEVICES, NAMELY, INHALERS AND NEBULIZERS, CONTAINING PRE-FILLED DRUG CARTRIDGES WHICH DELIVER MEDICATION VIA THE PULMONARY ROUTE FOR USE IN THE TREATMENT OR RESPIRATORY DISEASES AND DISORDERS (U.S. CLS. 6, 18, 44, 46, 51 AND 52).

ANTHONY RINKER, EXAMINING ATTORNEY

CLASS 5—(Continued).

SN 85-291,889. MAP PHARMACEUTICALS, INC., MOUNTAIN VIEW, CA. FILED 4-11-2011.

TOPRANA

THE MARK CONSISTS OF STANDARD CHARACTERS WITHOUT CLAIM TO ANY PARTICULAR FONT, STYLE, SIZE, OR COLOR.

FOR INHALED PHARMACEUTICAL PREPARATIONS FOR THE TREATMENT OF RESPIRATORY DISEASES AND DISORDERS; DRUG DELIVERY DEVICES, NAMELY, INHALERS AND NEBULIZERS, CONTAINING PRE-FILLED DRUG CARTRIDGES WHICH DELIVER MEDICATION VIA THE PULMONARY ROUTE FOR USE IN THE TREATMENT OR RESPIRATORY DISEASES AND DISORDERS (U.S. CLS. 6, 18, 44, 46, 51 AND 52).

ANTHONY RINKER, EXAMINING ATTORNEY

SN 85-292,045. O'DONOHUE, KRISTIN M, DBA O'DONOHUE, KRISTIN M, GOLDEN VALLEY, AZ. FILED 4-11-2011.

The Topsy Witch

THE MARK CONSISTS OF STANDARD CHARACTERS WITHOUT CLAIM TO ANY PARTICULAR FONT, STYLE, SIZE, OR COLOR.

FOR THERAPEUTIC SPELL KITS COMPRISING PORTIONS AND HERBS USED FOR PERSONAL GROWTH AND SELF DISCOVERY (U.S. CLS. 6, 18, 44, 46, 51 AND 52).

WENDY JUN, EXAMINING ATTORNEY

SN 85-292,101. LEAN-SLIM LLC, LAS VEGAS, NV. FILED 4-11-2011.

LEAN-SLIM

THE MARK CONSISTS OF STANDARD CHARACTERS WITHOUT CLAIM TO ANY PARTICULAR FONT, STYLE, SIZE, OR COLOR.

FOR SUPPLEMENTS, NAMELY, DIETARY FOOD SUPPLEMENTS, DIETARY SUPPLEMENTS, FOOD SUPPLEMENTS, HERBAL SUPPLEMENTS, MEAL REPLACEMENT AND DIETARY SUPPLEMENT DRINK MIXES, MINERAL NUTRITIONAL SUPPLEMENTS, MINERAL SUPPLEMENTS, NUTRITIONAL SUPPLEMENTS, NUTRITIONAL SUPPLEMENT DRINK MIX, VITAMIN AND MINERAL SUPPLEMENTS, VITAMIN SUPPLEMENTS, MEAL REPLACEMENT BARS (U.S. CLS. 6, 18, 44, 46, 51 AND 52).

KATHY DE JONGE, EXAMINING ATTORNEY

CLASS 5—(Continued).

SN 85-292,284. MY NATURAL RELIEF, LLC, PROVO, UT. FILED 4-11-2011.

XSOMNIA

THE MARK CONSISTS OF STANDARD CHARACTERS WITHOUT CLAIM TO ANY PARTICULAR FONT, STYLE, SIZE, OR COLOR.

FOR DIETARY SUPPLEMENTS (U.S. CLS. 6, 18, 44, 46, 51 AND 52).

FIRST USE 6-1-2008; IN COMMERCE 6-1-2008.

ANN E. SAPPENFIELD, EXAMINING ATTORNEY

SN 85-292,291. MY NATURAL RELIEF, LLC, PROVO, UT. FILED 4-11-2011.

XMOOD

THE MARK CONSISTS OF STANDARD CHARACTERS WITHOUT CLAIM TO ANY PARTICULAR FONT, STYLE, SIZE, OR COLOR.

FOR DIETARY SUPPLEMENTS (U.S. CLS. 6, 18, 44, 46, 51 AND 52).

FIRST USE 6-1-2008; IN COMMERCE 6-1-2008.

ANN E. SAPPENFIELD, EXAMINING ATTORNEY

SN 85-292,367. SUNMED USA, LLC, VALENCIA, CA. FILED 4-11-2011.

1st Safety

THE MARK CONSISTS OF STANDARD CHARACTERS WITHOUT CLAIM TO ANY PARTICULAR FONT, STYLE, SIZE, OR COLOR.

FOR ADHESIVE BANDAGES; ADHESIVE FOR BANDAGES FOR SKIN WOUNDS; ANTISEPTIC COTTON; ANTISEPTIC LIQUID BANDAGES; ANTISEPTIC PREPARATIONS; ANTISEPTIC WIPES; ANTISEPTICS; BANDAGES FOR DRESSINGS; BANDAGES FOR SKIN WOUNDS; BANDAGES IMPREGNATED WITH ANTI-SEPTIC OR BURN RELIEF GEL; BURN DRESSINGS; BURN RELIEF MEDICATION; DRESSINGS FOR BURNS, CUTS, AND INJURIES; FIRST AID KITS; FIRST AID KITS FOR DOMESTIC OR OTHER NON-PROFESSIONAL USE; GAUZE; GAUZE FOR DRESSINGS; KITS COMPRISING SANITIZER GEL, DISINFECTING WIPES, SANITARY MASKS, PLASTIC GLOVES AND HAND CREAM USED FOR GERM PREVENTION; PHARMACEUTICAL PREPARATIONS, NAMELY, A BLOOD CLOTTING AID AND DELIVERY SYSTEM FOR USE IN HUMAN AND VETERINARY MEDICINE; SURGICAL BANDAGES; TOPICAL FIRST AID GEL (U.S. CLS. 6, 18, 44, 46, 51 AND 52).

FRANK LATTUCA, EXAMINING ATTORNEY

CLASS 5—(Continued).

SN 85-292,394. CHARAK PHARMA PVT. LTD., TA CHARAK PHARMA PVT. LTD., MAHALAXMI, MUMBAI 400011, INDIA, FILED 4-12-2011.

INNOVEDA

THE MARK CONSISTS OF STANDARD CHARACTERS WITHOUT CLAIM TO ANY PARTICULAR FONT, STYLE, SIZE, OR COLOR.

FOR DIETARY AND NUTRITIONAL SUPPLEMENTS FOR HUMAN CONSUMPTION (U.S. CLS. 6, 18, 44, 46, 51 AND 52).

MELISSA VALLILLO, EXAMINING ATTORNEY

SN 85-292,412. CHARAK PHARMA PVT. LTD., TA CHARAK PHARMA PVT. LTD., MAHALAXMI, MUMBAI 400011, INDIA, FILED 4-12-2011.

PHYTONOVA

THE MARK CONSISTS OF STANDARD CHARACTERS WITHOUT CLAIM TO ANY PARTICULAR FONT, STYLE, SIZE, OR COLOR.

FOR DIETARY AND NUTRITIONAL SUPPLEMENTS FOR HUMAN CONSUMPTION (U.S. CLS. 6, 18, 44, 46, 51 AND 52).

MELISSA VALLILLO, EXAMINING ATTORNEY

SN 85-292,452. BACON PRODUCTS CORPORATION, CHATTANOOGA, TN. FILED 4-12-2011.

MY BUDDY ORGANIC DIP

THE MARK CONSISTS OF STANDARD CHARACTERS WITHOUT CLAIM TO ANY PARTICULAR FONT, STYLE, SIZE, OR COLOR.

OWNER OF U.S. REG. NOS. 1,533,112, 2,955,242 AND OTHERS.

NO CLAIM IS MADE TO THE EXCLUSIVE RIGHT TO USE "ORGANIC DIP", APART FROM THE MARK AS SHOWN.

FOR PET CARE PRODUCTS, NAMELY, ORGANIC FLEA, TICK, AND LICE DIP FOR DOGS (U.S. CLS. 6, 18, 44, 46, 51 AND 52).

FIRST USE 2-10-2010; IN COMMERCE 2-10-2010.

PAM WILLIS, EXAMINING ATTORNEY

CLASS 5—(Continued).

SN 85-292,778. DESIGNS FOR HEALTH, INC., SUFFIELD, CT. FILED 4-12-2011.

SITOMEDICA

THE MARK CONSISTS OF STANDARD CHARACTERS WITHOUT CLAIM TO ANY PARTICULAR FONT, STYLE, SIZE, OR COLOR.

FOR MEDICAL FOODS SPECIFICALLY FORMULATED AND PROCESSED FOR A PATIENT'S DEFINED HEALTH PROBLEMS (U.S. CLS. 6, 18, 44, 46, 51 AND 52).
ZACHARY BELLO, EXAMINING ATTORNEY

SN 85-292,846. IMMUTRITION, SAN DIEGO, CA. FILED 4-12-2011.

Immutides

THE MARK CONSISTS OF STANDARD CHARACTERS WITHOUT CLAIM TO ANY PARTICULAR FONT, STYLE, SIZE, OR COLOR.

FOR DIETARY AND NUTRITIONAL SUPPLEMENTS (U.S. CLS. 6, 18, 44, 46, 51 AND 52).
FIRST USE 12-3-2006; IN COMMERCE 12-3-2006.
KRISTINA MORRIS, EXAMINING ATTORNEY

SN 85-292,900. IMMUTRITION, SAN DIEGO, CA. FILED 4-12-2011.

iCare

THE MARK CONSISTS OF STANDARD CHARACTERS WITHOUT CLAIM TO ANY PARTICULAR FONT, STYLE, SIZE, OR COLOR.

FOR DIETARY AND NUTRITIONAL SUPPLEMENTS; DIETARY SUPPLEMENTS FOR ANIMALS; DIETARY SUPPLEMENTS FOR HUMAN CONSUMPTION; DIETARY SUPPLEMENTS FOR PETS (U.S. CLS. 6, 18, 44, 46, 51 AND 52).

FIRST USE 4-1-2010; IN COMMERCE 1-1-2011.
KRISTINA MORRIS, EXAMINING ATTORNEY

CLASS 5—(Continued).

SN 85-293,456. TRIGG LABORATORIES, INC., VALENCIA, CA. FILED 4-12-2011.



OWNER OF U.S. REG. NOS. 2,201,884, 2,668,557 AND OTHERS.

THE MARK CONSISTS OF "WET" IN BLOCK CAPITAL LETTERS INSIDE A SPLASH OF LIQUID, BORDERED ON EACH SIDE BY A LAUREL FROND/LEAF AND TOPPED WITH A EUROPEAN-STYLE CROWN; "PLATINUM" IN ALL CAPITAL LETTERS IS WRITTEN INSIDE A BLACK RECTANGLE BELOW THE SPLASH AND THE RECTANGLE ATTACHES AT EACH OF ITS TOP CORNERS TO THE BOTTOM OF THE LAUREL FRONDS/LEAVES.

FOR GELS FOR USE AS PERSONAL LUBRICANT; PERSONAL LUBRICANTS; PERSONAL SEXUAL LUBRICANTS; SILICONE-BASED PERSONAL LUBRICANTS; SKIN LUBRICANTS FOR ATHLETES TO PREVENT SKIN CHAFING (U.S. CLS. 6, 18, 44, 46, 51 AND 52).

FIRST USE 1-1-1997; IN COMMERCE 1-1-1997.
KARANENDRA S. CHHINA, EXAMINING ATTORNEY

SN 85-293,493. IMPORT & EXPORT TRADING, LLC, SOUTH RIDING, VA. FILED 4-12-2011.

VITAKIST

THE MARK CONSISTS OF STANDARD CHARACTERS WITHOUT CLAIM TO ANY PARTICULAR FONT, STYLE, SIZE, OR COLOR.

FOR DIETARY SUPPLEMENTS; NUTRITIONAL SUPPLEMENTS; VITAMIN AND MINERAL SUPPLEMENTS; VITAMINS (U.S. CLS. 6, 18, 44, 46, 51 AND 52).

VIVIAN MICZNIK FIRST, EXAMINING ATTORNEY

CLASS 5—(Continued).

SN 85-293,562. HYDROPOUCH CORPORATION, CHICAGO, IL. FILED 4-13-2011.

TORQ

THE MARK CONSISTS OF STANDARD CHARACTERS WITHOUT CLAIM TO ANY PARTICULAR FONT, STYLE, SIZE, OR COLOR.

OWNER OF U.S. REG. NO. 3,478,051.
FOR MINERAL, VITAMIN, OR NUTRITIONALLY ENHANCED WATER (U.S. CLS. 6, 18, 44, 46, 51 AND 52).
FIRST USE 4-9-2008; IN COMMERCE 4-9-2008.
NAKIA HENRY, EXAMINING ATTORNEY

SN 85-293,842. CYMBIOTICS, INC., ESCONDIDO, CA. FILED 4-13-2011.

Diaperin

THE MARK CONSISTS OF STANDARD CHARACTERS WITHOUT CLAIM TO ANY PARTICULAR FONT, STYLE, SIZE, OR COLOR.

FOR ANALGESIC AND MUSCLE RELAXANT PHARMACEUTICAL PREPARATIONS; ANALGESIC BALM; ANALGESICS; ANTI-DIABETIC PHARMACEUTICALS; BALMS FOR PHARMACEUTICAL PURPOSES; PAIN RELIEF MEDICATION; PHARMACEUTICAL PREPARATIONS FOR TREATING DIABETES; PREPARATION FOR THE RELIEF OF PAIN; TOPICAL ANALGESIC CREAMS; TOPICAL ANALGESICS; TOPICAL GEL FOR MEDICAL AND THERAPEUTIC TREATMENT OF PERIPHERAL NEUROPATHIES (U.S. CLS. 6, 18, 44, 46, 51 AND 52).
LAURIE KAUFMAN, EXAMINING ATTORNEY

SN 85-293,901. MERCK SHARP & DOHME CORP., WHITEHOUSE STATION, NJ. FILED 4-13-2011.

TESOZOR

THE MARK CONSISTS OF STANDARD CHARACTERS WITHOUT CLAIM TO ANY PARTICULAR FONT, STYLE, SIZE, OR COLOR.

FOR PHARMACEUTICAL PREPARATIONS FOR THE TREATMENT AND PREVENTION OF DIABETES (U.S. CLS. 6, 18, 44, 46, 51 AND 52).

NICHOLAS ALTREE, EXAMINING ATTORNEY

CLASS 5—(Continued).

SN 85-294,109. FUNCTIONAL FOODS INC., LONG BEACH, CA. FILED 4-13-2011.

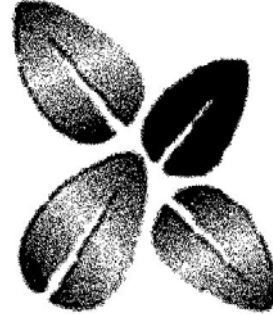

THE STIPPLING IS FOR SHADING PURPOSES ONLY.
THE MARK CONSISTS OF A FOUR LEAF DESIGN OF THREE DIFFERENT SIZES OF LEAVES.

FOR NUTRITIONAL FOOD BARS FOR USE AS A MEAL REPLACEMENT; NUTRITIONALLY FORTIFIED BEVERAGES; POWDERED NUTRITIONAL SUPPLEMENT DRINK MIX (U.S. CLS. 6, 18, 44, 46, 51 AND 52).
FIRST USE 6-9-2009; IN COMMERCE 1-2-2011.
CHRISTINE MARTIN, EXAMINING ATTORNEY

SN 85-294,130. FOCUS HEALTH GROUP, INC., KNOXVILLE, TN. FILED 4-13-2011.

ANECREAM5

THE MARK CONSISTS OF STANDARD CHARACTERS WITHOUT CLAIM TO ANY PARTICULAR FONT, STYLE, SIZE, OR COLOR.

OWNER OF U.S. REG. NO. 3,579,632.
FOR TOPICAL ANESTHETICS (U.S. CLS. 6, 18, 44, 46, 51 AND 52).
CHRISTINE MARTIN, EXAMINING ATTORNEY

SN 85-294,143. GLANBIA NUTRITIONALS (IRELAND) LIMITED, KILKENNY, IRELAND, FILED 4-13-2011.

HYPER AMINOX

THE MARK CONSISTS OF STANDARD CHARACTERS WITHOUT CLAIM TO ANY PARTICULAR FONT, STYLE, SIZE, OR COLOR.

FOR DIETARY SUPPLEMENTS (U.S. CLS. 6, 18, 44, 46, 51 AND 52).

BARBARA RUTLAND, EXAMINING ATTORNEY

CLASS 5—(Continued).

SN 85-294,148. GASPARI NUTRITION, INC., LAKEWOOD, NJ. FILED 4-13-2011.

PTEROTROPIN

THE MARK CONSISTS OF STANDARD CHARACTERS WITHOUT CLAIM TO ANY PARTICULAR FONT, STYLE, SIZE, OR COLOR.
FOR DIETARY AND NUTRITIONAL SUPPLEMENTS (U.S. CLS. 6, 18, 44, 46, 51 AND 52).
RONALD MCMORROW, EXAMINING ATTORNEY

SN 85-294,155. GASPARI NUTRITION, INC., LAKEWOOD, NJ. FILED 4-13-2011.

PTEROGEN

THE MARK CONSISTS OF STANDARD CHARACTERS WITHOUT CLAIM TO ANY PARTICULAR FONT, STYLE, SIZE, OR COLOR.
FOR DIETARY AND NUTRITIONAL SUPPLEMENTS (U.S. CLS. 6, 18, 44, 46, 51 AND 52).
RONALD MCMORROW, EXAMINING ATTORNEY

SN 85-294,160. GASPARI NUTRITION, INC., LAKEWOOD, NJ. FILED 4-13-2011.

PTEROBOLIC

THE MARK CONSISTS OF STANDARD CHARACTERS WITHOUT CLAIM TO ANY PARTICULAR FONT, STYLE, SIZE, OR COLOR.
FOR DIETARY AND NUTRITIONAL SUPPLEMENTS (U.S. CLS. 6, 18, 44, 46, 51 AND 52).
RONALD MCMORROW, EXAMINING ATTORNEY

CLASS 5—(Continued).

SN 85-294,192. BRANDT CONSOLIDATED, INC., SPRINGFIELD, IL. FILED 4-13-2011.

TRITEK

THE MARK CONSISTS OF STANDARD CHARACTERS WITHOUT CLAIM TO ANY PARTICULAR FONT, STYLE, SIZE, OR COLOR.
FOR PESTICIDES FOR AGRICULTURAL USE (U.S. CLS. 6, 18, 44, 46, 51 AND 52).
VIVIAN MICZNIK FIRST, EXAMINING ATTORNEY

SN 85-294,348. NORTHWEST NATURAL PRODUCTS, INC., VANCOUVER, WA. FILED 4-13-2011.

GUMMYLICIOUS

THE MARK CONSISTS OF STANDARD CHARACTERS WITHOUT CLAIM TO ANY PARTICULAR FONT, STYLE, SIZE, OR COLOR.
FOR DIETARY AND NUTRITIONAL SUPPLEMENTS (U.S. CLS. 6, 18, 44, 46, 51 AND 52).
MARK SPARACINO, EXAMINING ATTORNEY

SN 85-294,457. MICROBASICS, SAN DIEGO, CA. FILED 4-13-2011.

NatraMin

THE MARK CONSISTS OF STANDARD CHARACTERS WITHOUT CLAIM TO ANY PARTICULAR FONT, STYLE, SIZE, OR COLOR.
FOR ANIMAL FEED SUPPLEMENTS; MINERAL NUTRITIONAL SUPPLEMENTS; MINERAL SUPPLEMENTS; NON-MEDICATED ADDITIVES FOR ANIMAL FEED FOR USE AS NUTRITIONAL SUPPLEMENTS (U.S. CLS. 6, 18, 44, 46, 51 AND 52).
FIRST USE 9-29-2009; IN COMMERCE 9-29-2009.
GRETTA YAO, EXAMINING ATTORNEY

CLASS 5—(Continued).

SN 85-294,573. SMART BEVERAGE COMPANY, INC., EL CAJON, CA. FILED 4-13-2011.

DEVILS TECH

THE MARK CONSISTS OF STANDARD CHARACTERS WITHOUT CLAIM TO ANY PARTICULAR FONT, STYLE, SIZE, OR COLOR.

FOR DIETARY SUPPLEMENTS; MINERAL SUPPLEMENTS; NUTRITIONAL SUPPLEMENTS; VITAMIN SUPPLEMENTS (U.S. CLS. 6, 18, 44, 46, 51 AND 52).
DAVID H. STINE, EXAMINING ATTORNEY

SN 85-295,197. SHAKLEE CORPORATION, PLEASANTON, CA. FILED 4-14-2011.

OPTI LYTE

THE MARK CONSISTS OF THE WORD "OPTI LYTE" WITH A LEAF DESIGN IN BETWEEN "OPTI" AND "LYTE".

FOR POWDERED NUTRITIONAL SUPPLEMENT COMPOSED OF ELECTROLYTES AND CARBOHYDRATES (U.S. CLS. 6, 18, 44, 46, 51 AND 52).
JOHN HWANG, EXAMINING ATTORNEY

SN 85-295,391. MINNTECH CORPORATION, MINNEAPOLIS, MN. FILED 4-14-2011.

BIOTRU

THE MARK CONSISTS OF STANDARD CHARACTERS WITHOUT CLAIM TO ANY PARTICULAR FONT, STYLE, SIZE, OR COLOR.

FOR ANTIMICROBIAL, ANTIBACTERIAL AND ANTIFUNGAL ADDITIVE FOR USE AS AN INGREDIENT IN A DEODORIZING SPRAY FOR USE ON FABRIC, SPORTS EQUIPMENT, GYM EQUIPMENT AND HARD SURFACES (U.S. CLS. 6, 18, 44, 46, 51 AND 52).
KAREN BRACEY, EXAMINING ATTORNEY

CLASS 5—(Continued).

SN 85-295,615. FREEMAN, JERAMY K., EAST SYRACUSE, NY. FILED 4-14-2011.

UPGRADE

THE MARK CONSISTS OF STANDARD CHARACTERS WITHOUT CLAIM TO ANY PARTICULAR FONT, STYLE, SIZE, OR COLOR.

FOR DIETARY AND NUTRITIONAL SUPPLEMENTS (U.S. CLS. 6, 18, 44, 46, 51 AND 52).

MICHAEL TANNER, EXAMINING ATTORNEY

SN 85-295,709. HYPER NETWORK SOLUTIONS, LLC, WEST PALM BEACH, FL. FILED 4-14-2011.

FORPLAY

THE MARK CONSISTS OF STANDARD CHARACTERS WITHOUT CLAIM TO ANY PARTICULAR FONT, STYLE, SIZE, OR COLOR.

FOR DIETARY AND NUTRITIONAL SUPPLEMENTS (U.S. CLS. 6, 18, 44, 46, 51 AND 52).

CHRISTOPHER BUONGIORNO, EXAMINING ATTORNEY

SN 85-295,813. GRENADE BEVERAGE LLC, ORANGE, CA. FILED 4-14-2011.

El Gallito

THE MARK CONSISTS OF STANDARD CHARACTERS WITHOUT CLAIM TO ANY PARTICULAR FONT, STYLE, SIZE, OR COLOR.

THE ENGLISH TRANSLATION OF "EL GALLITO" IN THE MARK IS "THE LITTLE ROOSTER".

FOR DIETARY SUPPLEMENTS FOR RELIEF AND PREVENTION OF FATIGUE; HOMEOPATHIC SUPPLEMENTS; NUTRITIONAL SUPPLEMENTS FOR RELIEF AND PREVENTION OF FATIGUE (U.S. CLS. 6, 18, 44, 46, 51 AND 52).
WENDY JUN, EXAMINING ATTORNEY

CLASS 5—(Continued).

SN 85-295,863. MEDCHEM MANUFACTURING, INC., TORRANCE, CA. FILED 4-15-2011.

MNS

THE MARK CONSISTS OF STANDARD CHARACTERS WITHOUT CLAIM TO ANY PARTICULAR FONT, STYLE, SIZE, OR COLOR.

FOR NUTRITIONAL SUPPLEMENTS (U.S. CLS. 6, 18, 44, 46, 51 AND 52).
ANGELA DUONG, EXAMINING ATTORNEY

SN 85-295,869. MEDCHEM MANUFACTURING, INC., TORRANCE, CA. FILED 4-15-2011.

CARTIVISC

THE MARK CONSISTS OF STANDARD CHARACTERS WITHOUT CLAIM TO ANY PARTICULAR FONT, STYLE, SIZE, OR COLOR.

FOR NUTRITIONAL SUPPLEMENTS (U.S. CLS. 6, 18, 44, 46, 51 AND 52).
FIRST USE 3-28-2011; IN COMMERCE 3-28-2011.
ANGELA DUONG, EXAMINING ATTORNEY

SN 85-295,872. MEDCHEM MANUFACTURING, INC., TORRANCE, CA. FILED 4-15-2011.

MYOFIBEX

THE MARK CONSISTS OF STANDARD CHARACTERS WITHOUT CLAIM TO ANY PARTICULAR FONT, STYLE, SIZE, OR COLOR.

FOR NUTRITIONAL SUPPLEMENTS (U.S. CLS. 6, 18, 44, 46, 51 AND 52).
ANGELA DUONG, EXAMINING ATTORNEY

CLASS 5—(Continued).

SN 85-295,873. MEDCHEM MANUFACTURING, INC., TORRANCE, CA. FILED 4-15-2011.

RESTONE

THE MARK CONSISTS OF STANDARD CHARACTERS WITHOUT CLAIM TO ANY PARTICULAR FONT, STYLE, SIZE, OR COLOR.

FOR NUTRITIONAL SUPPLEMENTS (U.S. CLS. 6, 18, 44, 46, 51 AND 52).
ANGELA DUONG, EXAMINING ATTORNEY

SN 85-296,252. MERCK SHARP & DOHME CORP., WHITEHOUSE STATION, NJ. FILED 4-15-2011.

KELVEON

THE MARK CONSISTS OF STANDARD CHARACTERS WITHOUT CLAIM TO ANY PARTICULAR FONT, STYLE, SIZE, OR COLOR.

FOR PHARMACEUTICAL PREPARATIONS FOR THE TREATMENT OF ALLERGIC CONDITIONS, CANCER, DIABETES, INFECTIOUS DISEASES AND INFERTILITY; PHARMACEUTICAL PREPARATIONS FOR THE TREATMENT OF CARDIOVASCULAR, CENTRAL NERVOUS SYSTEM, DERMATOLOGICAL, METABOLIC, MUSCULOSKELETAL, OPHTHALMOLOGICAL AND RESPIRATORY DISEASES AND DISORDERS; ANALGESIC PREPARATIONS, CONTRACEPTIVES, IMMUNOLOGICAL PREPARATIONS AND VACCINES FOR HUMAN USE (U.S. CLS. 6, 18, 44, 46, 51 AND 52).

NICHOLAS ALTREE, EXAMINING ATTORNEY

SN 85-297,599. FOCUS HEALTH GROUP, INC., KNOXVILLE, TN. FILED 4-18-2011.



The logo for ANECREAM5 features the word "ANECREAM" in a green, sans-serif font, followed by a large, stylized number "5" in a blue, sans-serif font.

OWNER OF U.S. REG. NO. 3,579,632.
THE COLOR(S) GREEN AND BLUE IS/ARE CLAIMED AS A FEATURE OF THE MARK.

THE MARK CONSISTS OF THE PHRASE "ANECREAM5" IN CAPITAL LETTERS, WITH A LARGER SIZED LETTER "C" AND ALL THE LETTERS IN THE COLOR GREEN; THE NUMBER FIVE IS LARGER THAN THE LETTERS AND IN THE COLOR BLUE.

FOR TOPICAL ANESTHETICS (U.S. CLS. 6, 18, 44, 46, 51 AND 52).
CHRISTINE MARTIN, EXAMINING ATTORNEY

CLASS 5—(Continued).

SN 85-298,104. FUNCTIONAL FOODS INC., LONG BEACH, CA. FILED 4-18-2011.

Nourish the body, energize
the mind

THE MARK CONSISTS OF STANDARD CHARACTERS WITHOUT CLAIM TO ANY PARTICULAR FONT, STYLE, SIZE, OR COLOR.

FOR NUTRITIONAL FOOD BARS FOR USE AS A MEAL REPLACEMENT; NUTRITIONALLY FORTIFIED BEVERAGES; POWDERED NUTRITIONAL SUPPLEMENT DRINK MIX (U.S. CLS. 6, 18, 44, 46, 51 AND 52).
FIRST USE 6-9-2009; IN COMMERCE 1-2-2011.

CHRISTINE MARTIN, EXAMINING ATTORNEY

SN 85-299,035. AMERIFIT, INC., CROMWELL, CT. FILED 4-19-2011.

AZO PMS RELIEF

THE MARK CONSISTS OF STANDARD CHARACTERS WITHOUT CLAIM TO ANY PARTICULAR FONT, STYLE, SIZE, OR COLOR.

OWNER OF U.S. REG. NOS. 2,349,020, 3,070,332 AND OTHERS.

NO CLAIM IS MADE TO THE EXCLUSIVE RIGHT TO USE "PMS RELIEF", APART FROM THE MARK AS SHOWN.

FOR DIETARY AND NUTRITIONAL SUPPLEMENTS; DIETARY AND NUTRITIONAL SUPPLEMENTS FOR THE TREATMENT OF PREMENSTRUAL SYNDROME (U.S. CLS. 6, 18, 44, 46, 51 AND 52).

LEIGH CAROLINE CASE, EXAMINING ATTORNEY

SN 85-301,485. ECONUGENICS, INC., SANTA ROSA, CA. FILED 4-21-2011.

PECTASOL

THE MARK CONSISTS OF STANDARD CHARACTERS WITHOUT CLAIM TO ANY PARTICULAR FONT, STYLE, SIZE, OR COLOR.

OWNER OF U.S. REG. NO. 3,522,340.
FOR DIETARY SUPPLEMENTS (U.S. CLS. 6, 18, 44, 46, 51 AND 52).

FIRST USE 9-11-1996; IN COMMERCE 9-11-1996.

EMILY CARLSEN, EXAMINING ATTORNEY

CLASS 5—(Continued).

SN 85-303,164. WRIGHTWAY WELLNESS, LLC, HILLSBOROUGH, NC. FILED 4-25-2011.

DETOXOLITE

THE MARK CONSISTS OF STANDARD CHARACTERS WITHOUT CLAIM TO ANY PARTICULAR FONT, STYLE, SIZE, OR COLOR.

FOR DIETARY SUPPLEMENTS FOR HUMAN CONSUMPTION USED FOR SYSTEMIC DETOXIFICATION (U.S. CLS. 6, 18, 44, 46, 51 AND 52).

EMILY CHUO, EXAMINING ATTORNEY

SN 85-303,536. VITACOST.COM, INC., BOCA RATON, FL. FILED 4-25-2011.

WOMEN'S ESSENCE

THE MARK CONSISTS OF STANDARD CHARACTERS WITHOUT CLAIM TO ANY PARTICULAR FONT, STYLE, SIZE, OR COLOR.

NO CLAIM IS MADE TO THE EXCLUSIVE RIGHT TO USE "WOMEN'S", APART FROM THE MARK AS SHOWN.

FOR DIETARY AND NUTRITIONAL SUPPLEMENTS (U.S. CLS. 6, 18, 44, 46, 51 AND 52).

FIRST USE 4-21-2011; IN COMMERCE 4-21-2011.

MICHELLE DUBOIS, EXAMINING ATTORNEY

SN 85-303,944. TIBER LABORATORIES, LLC, SUWANEE, GA. FILED 4-25-2011.

FLOWTUSS

THE MARK CONSISTS OF STANDARD CHARACTERS WITHOUT CLAIM TO ANY PARTICULAR FONT, STYLE, SIZE, OR COLOR.

FOR PHARMACEUTICAL PREPARATIONS, NAMELY, COUGH AND COLD PREPARATIONS (U.S. CLS. 6, 18, 44, 46, 51 AND 52).

GRETCHEN ULRICH, EXAMINING ATTORNEY

CLASS 5—(Continued).

SN 85-303,948. TIBER LABORATORIES, LLC, SUWANEE, GA. FILED 4-25-2011.

CLASS 5—(Continued).

SN 85-308,159. VITACOST.COM, INC., BOCA RATON, FL. FILED 4-29-2011.

TUSICLAR

Men's Mega Active

THE MARK CONSISTS OF STANDARD CHARACTERS WITHOUT CLAIM TO ANY PARTICULAR FONT, STYLE, SIZE, OR COLOR.

FOR PHARMACEUTICAL PREPARATIONS, NAMELY, COUGH AND COLD PREPARATIONS (U.S. CLS. 6, 18, 44, 46, 51 AND 52).

GRETCHEN ULRICH, EXAMINING ATTORNEY

THE MARK CONSISTS OF STANDARD CHARACTERS WITHOUT CLAIM TO ANY PARTICULAR FONT, STYLE, SIZE, OR COLOR.

NO CLAIM IS MADE TO THE EXCLUSIVE RIGHT TO USE "MEN'S", APART FROM THE MARK AS SHOWN, FOR DIETARY AND NUTRITIONAL SUPPLEMENTS (U.S. CLS. 6, 18, 44, 46, 51 AND 52).

MICHELLE DUBOIS, EXAMINING ATTORNEY

SN 85-305,634. MYLAN PHARMACEUTICALS, INC., MORGANTOWN, WV. FILED 4-27-2011.

SN 85-308,163. VITACOST.COM, INC., BOCA RATON, FL. FILED 4-29-2011.

GIELLE

Women's Mega Active

THE MARK CONSISTS OF STANDARD CHARACTERS WITHOUT CLAIM TO ANY PARTICULAR FONT, STYLE, SIZE, OR COLOR.

FOR ORAL CONTRACEPTIVES (U.S. CLS. 6, 18, 44, 46, 51 AND 52).

HAI-LY LAM, EXAMINING ATTORNEY

THE MARK CONSISTS OF STANDARD CHARACTERS WITHOUT CLAIM TO ANY PARTICULAR FONT, STYLE, SIZE, OR COLOR.

NO CLAIM IS MADE TO THE EXCLUSIVE RIGHT TO USE "WOMEN'S", APART FROM THE MARK AS SHOWN, FOR DIETARY AND NUTRITIONAL SUPPLEMENTS (U.S. CLS. 6, 18, 44, 46, 51 AND 52).

MICHELLE DUBOIS, EXAMINING ATTORNEY

SN 85-305,680. MYLAN PHARMACEUTICALS, INC., MORGANTOWN, WV. FILED 4-27-2011.

SN 85-309,404. E5 LLC, HONOLULU, HI. FILED 5-2-2011.

JOSIE

PROHORMESIS

THE MARK CONSISTS OF STANDARD CHARACTERS WITHOUT CLAIM TO ANY PARTICULAR FONT, STYLE, SIZE, OR COLOR.

FOR ORAL CONTRACEPTIVES (U.S. CLS. 6, 18, 44, 46, 51 AND 52).

HAI-LY LAM, EXAMINING ATTORNEY

THE MARK CONSISTS OF STANDARD CHARACTERS WITHOUT CLAIM TO ANY PARTICULAR FONT, STYLE, SIZE, OR COLOR.

FOR DIETARY AND NUTRITIONAL SUPPLEMENTS (U.S. CLS. 6, 18, 44, 46, 51 AND 52).

KELLY BOULTON, EXAMINING ATTORNEY

CLASS 5—(Continued).

SN 85-310,922. PHARMAFREAK HOLDINGS INC., TORONTO, ONTARIO, CANADA, FILED 5-3-2011.

SUPER FREAK

THE MARK CONSISTS OF STANDARD CHARACTERS WITHOUT CLAIM TO ANY PARTICULAR FONT, STYLE, SIZE, OR COLOR.

OWNER OF U.S. REG. NOS. 3,932,856 AND 3,942,640.
FOR DIETARY AND NUTRITIONAL SUPPLEMENTS (U.S. CLS. 6, 18, 44, 46, 51 AND 52).
KARANENDRA S. CHHINA, EXAMINING ATTORNEY

CLASS 5—(Continued).

SN 85-317,744. BAYER AKTIENGESELLSCHAFT, 51373 LEVERKUSEN, FED REP GERMANY, FILED 5-11-2011.

POLYZONE

THE MARK CONSISTS OF STANDARD CHARACTERS WITHOUT CLAIM TO ANY PARTICULAR FONT, STYLE, SIZE, OR COLOR.

FOR PREPARATIONS FOR KILLING WEEDS AND DESTROYING VERMIN; INSECTICIDES, HERBICIDES, FUNGICIDES (U.S. CLS. 6, 18, 44, 46, 51 AND 52).
JENNIFER MARTIN, EXAMINING ATTORNEY

SN 85-312,064. BAYER AKTIENGESELLSCHAFT, LEVERKUSEN, FED REP GERMANY, FILED 5-4-2011.

ZARELTO

THE MARK CONSISTS OF STANDARD CHARACTERS WITHOUT CLAIM TO ANY PARTICULAR FONT, STYLE, SIZE, OR COLOR.

FOR PHARMACEUTICAL PREPARATIONS AND SUBSTANCES FOR THE PREVENTION AND TREATMENT OF CARDIOVASCULAR DISEASES, THROMBOSIS, STROKE AND PULMONARY EMBOLISM (U.S. CLS. 6, 18, 44, 46, 51 AND 52).

JENNIFER MARTIN, EXAMINING ATTORNEY

SN 85-318,052. DOW AGROSCIENCES LLC, INDIANAPOLIS, IN. FILED 5-11-2011.

CAPSTONE

THE MARK CONSISTS OF STANDARD CHARACTERS WITHOUT CLAIM TO ANY PARTICULAR FONT, STYLE, SIZE, OR COLOR.

FOR HERBICIDE FOR USE IN INDUSTRIAL RIGHTS OF WAYS (U.S. CLS. 6, 18, 44, 46, 51 AND 52).

MARY CRAWFORD, EXAMINING ATTORNEY

SN 85-314,991. BENTON THERAPEUTICS, INC., DIAMOND BAR, CA. FILED 5-6-2011.

Provides The Perfect
Balance Of Maximum Relief,
Safety, Comfort, And
Convenience

THE MARK CONSISTS OF STANDARD CHARACTERS WITHOUT CLAIM TO ANY PARTICULAR FONT, STYLE, SIZE, OR COLOR.

FOR NASAL SPRAY PREPARATIONS (U.S. CLS. 6, 18, 44, 46, 51 AND 52).

MICHELLE DUBOIS, EXAMINING ATTORNEY

SN 85-318,373. WINDMILL HEALTH PRODUCTS, LLC, WEST CALDWELL, NJ. FILED 5-11-2011.

BUZZ KILL

THE MARK CONSISTS OF STANDARD CHARACTERS WITHOUT CLAIM TO ANY PARTICULAR FONT, STYLE, SIZE, OR COLOR.

FOR DIETARY AND NUTRITIONAL SUPPLEMENTS (U.S. CLS. 6, 18, 44, 46, 51 AND 52).

LINDA POWELL, EXAMINING ATTORNEY

CLASS 5—(Continued).

SN 85-318,820. TEKQUEST INDUSTRIES CORPORATION, SANFORD, FL. FILED 5-12-2011.



NO CLAIM IS MADE TO THE EXCLUSIVE RIGHT TO USE "SINGLE SCOOP SOLUTION" OR "KITTY TESTED", APART FROM THE MARK AS SHOWN.

THE MARK CONSISTS OF A CIRCULAR BADGE BEARING THE WORDS "SINGLE SCOOP SOLUTION" BISECTED WITH THE IMAGE OF A SCOOP AND A BANNER BEARING THE WORDS "KITTY TESTED".

FOR DEODORIZERS FOR HOUSEHOLD PET LITTER BOXES (U.S. CLS. 6, 18, 44, 46, 51 AND 52).

FIRST USE 4-4-2011; IN COMMERCE 4-4-2011.

BRIAN PINO, EXAMINING ATTORNEY

SN 85-318,992. HUMAN PERFORMANCE NETWORK, LLC, MINNEAPOLIS, MN. FILED 5-12-2011.

NUTRITIONAL INSURANCE

THE MARK CONSISTS OF STANDARD CHARACTERS WITHOUT CLAIM TO ANY PARTICULAR FONT, STYLE, SIZE, OR COLOR.

NO CLAIM IS MADE TO THE EXCLUSIVE RIGHT TO USE "NUTRITIONAL", APART FROM THE MARK AS SHOWN.

FOR DIETARY SUPPLEMENTS (U.S. CLS. 6, 18, 44, 46, 51 AND 52).

MATTHEW MCDOWELL, EXAMINING ATTORNEY

CLASS 5—(Continued).

SN 85-319,472. KIMBERLY-CLARK WORLDWIDE, INC., NEENAH, WI. FILED 5-12-2011.

KLEENEX

THE MARK CONSISTS OF STANDARD CHARACTERS WITHOUT CLAIM TO ANY PARTICULAR FONT, STYLE, SIZE, OR COLOR.

OWNER OF U.S. REG. NOS. 297,536, 1,785,525 AND OTHERS.

FOR HAND-SANITIZING PREPARATIONS (U.S. CLS. 6, 18, 44, 46, 51 AND 52).

FIRST USE 2-28-2011; IN COMMERCE 2-28-2011.

JOHN HWANG, EXAMINING ATTORNEY

SN 85-319,942. TIBOTEC PHARMACEUTICALS, LITTLE ISLAND CO. CORK, IRELAND, FILED 5-13-2011.

VISVARO

THE MARK CONSISTS OF STANDARD CHARACTERS WITHOUT CLAIM TO ANY PARTICULAR FONT, STYLE, SIZE, OR COLOR.

FOR HUMAN PHARMACEUTICALS FOR THE TREATMENT OF INFECTIOUS-RELATED DISEASE, AUTO-IMMUNE AND INFLAMMATORY DISEASES, CARDIOVASCULAR DISEASES, CENTRAL NERVOUS SYSTEM DISEASES AND PAIN, DERMATOLOGIC DISORDERS, METABOLIC DISEASES, ANTI-VIRAL DISEASES, ONCOLOGIC DISEASES, RESPIRATORY DISEASES, OPHTHALMIC DISEASES, MUSCLE DYSTONIAS, WRINKLES AND SMOOTH MUSCLE DISORDERS, GASTRO-INTESTINAL DISEASES; HUMAN PHARMACEUTICALS FOR USE AS HEMOSTATIC AGENTS (U.S. CLS. 6, 18, 44, 46, 51 AND 52).

DAVID HOFFMAN, EXAMINING ATTORNEY

SN 85-320,003. BAYER AKTIENGESELLSCHAFT, 51373 LEVERKUSEN, FED REP GERMANY, FILED 5-13-2011.

BUILT FOR COMPLIANCE

THE MARK CONSISTS OF STANDARD CHARACTERS WITHOUT CLAIM TO ANY PARTICULAR FONT, STYLE, SIZE, OR COLOR.

FOR DIETARY SUPPLEMENTS INCLUSIVE OF CALCIUM SALT (U.S. CLS. 6, 18, 44, 46, 51 AND 52).

JENNIFER MARTIN, EXAMINING ATTORNEY

CLASS 5—(Continued).

SN 85-321,269. NEXT PROTEINS, INC., CARLSBAD, CA. FILED 5-15-2011.

Get Fizzed

THE MARK CONSISTS OF STANDARD CHARACTERS WITHOUT CLAIM TO ANY PARTICULAR FONT, STYLE, SIZE, OR COLOR.

FOR NUTRITIONAL SUPPLEMENT PREPARATIONS, NAMELY, PROTEIN SUPPLEMENT BEVERAGES AND PROTEIN SUPPLEMENT BEVERAGE CONCENTRATED POWDERS FOR USE AS A SUPPLEMENT DRINK MIX, NAMELY, PREPACKAGED INDIVIDUAL SERVING PROTEIN SUPPLEMENT BEVERAGE CONCENTRATED POWDERS, BULK PACKAGED PROTEIN SUPPLEMENT BEVERAGE CONCENTRATED POWDERS, AND MULTIPACKS OF PREPACKAGED INDIVIDUAL SERVING PROTEIN SUPPLEMENT BEVERAGE CONCENTRATED POWDERS; AND NUTRITIONAL SUPPLEMENTS IN THE FORM OF PROTEIN SUPPLEMENT CONCENTRATED SYRUPS FOR ADDITION TO OTHER DRINKS, NAMELY, PREPACKAGED INDIVIDUAL SERVING PROTEIN SUPPLEMENT BEVERAGE CONCENTRATED SYRUPS, BULK PACKAGED PROTEIN SUPPLEMENT BEVERAGE CONCENTRATED SYRUPS, AND MULTIPACKS OF PREPACKAGED INDIVIDUAL SERVING PROTEIN SUPPLEMENT BEVERAGE CONCENTRATED SYRUPS (U.S. CLS. 6, 18, 44, 46, 51 AND 52).

TEJBIR SINGH, EXAMINING ATTORNEY

SN 85-325,127. SYNGENTA PARTICIPATIONS AG, BASEL, SWITZERLAND, FILED 5-19-2011.

Derby

THE MARK CONSISTS OF STANDARD CHARACTERS WITHOUT CLAIM TO ANY PARTICULAR FONT, STYLE, SIZE, OR COLOR.

FOR INSECTICIDES FOR COMMERCIAL, DOMESTIC AND AGRICULTURAL USE (U.S. CLS. 6, 18, 44, 46, 51 AND 52).

JOHN HWANG, EXAMINING ATTORNEY

SN 85-325,681. GLANBIA NUTRITIONALS (IRELAND) LIMITED, KILKENNY, IRELAND, FILED 5-20-2011.

AMINOX

THE MARK CONSISTS OF STANDARD CHARACTERS WITHOUT CLAIM TO ANY PARTICULAR FONT, STYLE, SIZE, OR COLOR.

FOR DIETARY SUPPLEMENTS (U.S. CLS. 6, 18, 44, 46, 51 AND 52).

BARBARA RUTLAND, EXAMINING ATTORNEY

CLASS 5—(Continued).

SN 85-326,146. GLANBIA NUTRITIONALS (IRELAND) LIMITED, KILKENNY, IRELAND, FILED 5-20-2011.

AMINO_X

THE MARK CONSISTS OF THE WORD "AMINOX" WITH THE "X" PORTION APPEARING IN SUBSCRIPT.

FOR DIETARY SUPPLEMENTS (U.S. CLS. 6, 18, 44, 46, 51 AND 52).

BARBARA RUTLAND, EXAMINING ATTORNEY

SN 85-326,621. WEIDER GLOBAL NUTRITION, LLC, SALT LAKE CITY, UT. FILED 5-20-2011.

WHITE HOT

THE MARK CONSISTS OF STANDARD CHARACTERS WITHOUT CLAIM TO ANY PARTICULAR FONT, STYLE, SIZE, OR COLOR.

FOR DIETARY AND NUTRITIONAL SUPPLEMENTS; DIETARY SUPPLEMENTAL DRINKS; DIETARY SUPPLEMENTS; DIETARY SUPPLEMENTS FOR HUMAN CONSUMPTION; LIQUID NUTRITIONAL SUPPLEMENT; NUTRITIONAL SUPPLEMENTS (U.S. CLS. 6, 18, 44, 46, 51 AND 52).

PAUL E. FAHRENKOPF, EXAMINING ATTORNEY

SN 85-327,995. MAP PHARMACEUTICALS, INC., MOUNTAIN VIEW, CA. FILED 5-23-2011.

KELIXA

THE MARK CONSISTS OF STANDARD CHARACTERS WITHOUT CLAIM TO ANY PARTICULAR FONT, STYLE, SIZE, OR COLOR.

FOR PHARMACEUTICAL PRODUCTS FOR THE PREVENTION AND TREATMENT OF MIGRAINE AND HEADACHES (U.S. CLS. 6, 18, 44, 46, 51 AND 52).

ANTHONY RINKER, EXAMINING ATTORNEY

CLASS 5—(Continued).

SN 85-331,891. GIOVANNI COSMETICS, INC., RANCHO DOMINGUEZ, CA. FILED 5-26-2011.

DON'T BE FLAKY

THE MARK CONSISTS OF STANDARD CHARACTERS WITHOUT CLAIM TO ANY PARTICULAR FONT, STYLE, SIZE, OR COLOR.

FOR MEDICATED HAIR CARE PRODUCTS AND PREPARATIONS, NAMELY, SHAMPOOS, CONDITIONERS, SCALP TONIC (U.S. CLS. 6, 18, 44, 46, 51 AND 52).

ANDREA K. NADELMAN, EXAMINING ATTORNEY

SN 85-331,892. GIOVANNI COSMETICS, INC., RANCHO DOMINGUEZ, CA. FILED 5-26-2011.

NO ONE LIKES A FLAKE

THE MARK CONSISTS OF STANDARD CHARACTERS WITHOUT CLAIM TO ANY PARTICULAR FONT, STYLE, SIZE, OR COLOR.

FOR MEDICATED HAIR CARE PRODUCTS AND PREPARATIONS, NAMELY, SHAMPOOS, CONDITIONERS, SCALP TONIC (U.S. CLS. 6, 18, 44, 46, 51 AND 52).

ANDREA K. NADELMAN, EXAMINING ATTORNEY

SN 85-336,922. CARDIUM THERAPEUTICS, INC., SAN DIEGO, CA. FILED 6-2-2011.

CARDIUM THERAPEUTICS

THE MARK CONSISTS OF STANDARD CHARACTERS WITHOUT CLAIM TO ANY PARTICULAR FONT, STYLE, SIZE, OR COLOR.

NO CLAIM IS MADE TO THE EXCLUSIVE RIGHT TO USE "THERAPEUTICS", APART FROM THE MARK AS SHOWN.

FOR CARDIOVASCULAR PHARMACEUTICALS; CARDIOVASCULAR TREATMENT PREPARATIONS; PRESCRIPTION AND NON-PRESCRIPTION MEDICINES, NAMELY, PILLS, TABLETS, CAPSULES, CAPLETS, LIQUID DROPS, SACHETS AND PHARMACEUTICAL PREPARATIONS FOR THE TREATMENT OF CARDIOVASCULAR DISORDERS (U.S. CLS. 6, 18, 44, 46, 51 AND 52).

JORDAN BAKER, EXAMINING ATTORNEY

CLASS 5—(Continued).

SN 85-975,445. FROM FATIGUED TO FANTASTIC LLC, KAILUA KONA, HI. FILED 3-22-2011.

S.H.I.N.E.

THE MARK CONSISTS OF STANDARD CHARACTERS WITHOUT CLAIM TO ANY PARTICULAR FONT, STYLE, SIZE, OR COLOR.

FOR DIETARY, NUTRITIONAL AND HEALTH FOOD SUPPLEMENTS (U.S. CLS. 6, 18, 44, 46, 51 AND 52).

DORITT L. CARROLL, EXAMINING ATTORNEY

CLASS 6—METAL GOODS

SN 76-704,246. ESTATE METALS, LLC, BENNINGTON, NE. FILED 8-25-2010.

ESTATE METALS

THE MARK CONSISTS OF STANDARD CHARACTERS WITHOUT CLAIM TO ANY PARTICULAR FONT, STYLE, SIZE, OR COLOR.

NO CLAIM IS MADE TO THE EXCLUSIVE RIGHT TO USE "METALS", APART FROM THE MARK AS SHOWN.

FOR ORNAMENTAL METAL BUILDING MATERIALS, NAMELY, RAILS, FENCES, GATES, AND RELATED ACCESSORIES, EXCLUDING MAILBOXES, MAILBOX POSTS AND COMPONENT PARTS USED FOR FASTENING AND SECURING MAILBOXES (U.S. CLS. 2, 12, 13, 14, 23, 25 AND 50).

FIRST USE 10-10-2007; IN COMMERCE 5-30-2009.

JULIE GUTTADAURO, EXAMINING ATTORNEY

CLASS 6—(Continued).

SN 79-081,657. CARDO ENTRANCE SOLUTIONS AB, SWEDEN, FILED 12-21-2009.

SECUREFOLD

THE MARK CONSISTS OF STANDARD CHARACTERS WITHOUT CLAIM TO ANY PARTICULAR FONT, STYLE, SIZE, OR COLOR.

PRIORITY DATE OF 7-9-2009 IS CLAIMED.
OWNER OF INTERNATIONAL REGISTRATION 1036209 DATED 12-21-2009, EXPIRES 12-21-2019.

FOR COMMON METALS AND THEIR ALLOYS; INCLUDING STAINLESS STEEL; TRANSPORTABLE BUILDINGS OF METAL; MATERIALS OF METAL FOR RAILWAY TRACKS; NON-ELECTRIC CABLES AND WIRES OF COMMON METAL; PIPES AND TUBES OF METAL; METAL SAFES; METAL HARDWARE FOR DOORS, WINDOWS AND SHUTTERS, NAMELY, RAILS AND TRACKS, BRACKETS, TROLLEYS, HANGERS, OVERHEAD RUNWAYS, ROLLERS, ROLLING MECHANISMS, FIXING APRONS, BOLTS, FLUSH PULLS, DOOR PULLS, DOOR GUIDES, GUIDE ROLLERS, SPRING LOADED GUIDES, CHANNELS, WHEELS, BEARINGS, HINGES, PIVOT SETS, BOTTOM SOCKETS, TOP SOCKETS, END HANGER SETS, INTERMEDIATE HANGER SETS, THRESHOLD, KICK PLATES, CATCHES, LATCHES AND DOOR LOCKS (U.S. CLS. 2, 12, 13, 14, 23, 25 AND 50).

WARREN L. OLANDRIA, EXAMINING ATTORNEY

CLASS 6—(Continued).

SN 85-146,854. CERRO FABRICATED PRODUCTS LLC, WEYERS CAVE, VA. FILED 10-6-2010.



THE MARK CONSISTS OF A DESIGN OF A KEY HOLE FOR METAL FORGINGS (U.S. CLS. 2, 12, 13, 14, 23, 25 AND 50).

FIRST USE 0-0-1971; IN COMMERCE 0-0-1971.
LAURIE KAUFMAN, EXAMINING ATTORNEY

SN 85-131,097. EXPRESS PRODUCTS, INC., WYOMING, MI. FILED 9-16-2010.



NO CLAIM IS MADE TO THE EXCLUSIVE RIGHT TO USE "DOOR HANGER", APART FROM THE MARK AS SHOWN.

THE MARK CONSISTS OF THE WORDS "THE QUICK" STACKED ON TOP OF EACH OTHER NEXT TO THE WORD "DOOR" ALL OF WHICH ARE ON TOP OF THE WORD "HANGER".

FOR HARDWARE, NAMELY, METAL BRACKETS AND METAL SCREWS TO HANG DOORS (U.S. CLS. 2, 12, 13, 14, 23, 25 AND 50).

FIRST USE 9-1-2010; IN COMMERCE 9-1-2010.
NAPOLEON SHARMA, EXAMINING ATTORNEY

SN 85-181,603. ONBOARD SYSTEMS, INC., VANCOUVER, WA. FILED 11-19-2010.

TALON

THE MARK CONSISTS OF STANDARD CHARACTERS WITHOUT CLAIM TO ANY PARTICULAR FONT, STYLE, SIZE, OR COLOR.

FOR METAL HOOKS HAVING POLYMER FITTINGS, PROTECTIVE METAL CAGES, AND POLYMER-COATED METAL CABLES FOR USE IN HELICOPTER CARGO LIFTING, AND OWNER'S MANUALS AND SERVICE MANUALS SOLD AS A UNIT THEREWITH, AND REPLACEMENT PARTS THEREFOR (U.S. CLS. 2, 12, 13, 14, 23, 25 AND 50).

FIRST USE 12-31-1998; IN COMMERCE 12-31-1998.
PATRICIA EVANKO, EXAMINING ATTORNEY

CLASS 6—(Continued).

SN 85-184,996. CHARTWELL LLC, EASTON, PA. FILED 11-24-2010.

"Material that powers the world"

THE MARK CONSISTS OF STANDARD CHARACTERS WITHOUT CLAIM TO ANY PARTICULAR FONT, STYLE, SIZE, OR COLOR.

FOR COLD-FINISHED STEEL BARS; ROLLED STEELS; SHEETS OF METAL INCLUDING THOSE FROM ALLOY STEEL AND TITANIUM; SLABS OF METAL INCLUDING THOSE FROM ALLOY STEEL AND TITANIUM; STAINLESS STEELS; STEEL; STEEL ALLOYS; STEEL IN SHEET, ROD, BAR AND/OR BILLET FORM; STEEL IN THE FORM OF SHEETS, PLATES, FOILS AND COILS (U.S. CLS. 2, 12, 13, 14, 23, 25 AND 50).

KAREN K. BUSH, EXAMINING ATTORNEY



SN 85-255,576. TRITON PRODUCTS, SOLON, OH. FILED 3-2-2011.

LocBoard

THE MARK CONSISTS OF STANDARD CHARACTERS WITHOUT CLAIM TO ANY PARTICULAR FONT, STYLE, SIZE, OR COLOR.

FOR GENERAL PURPOSE METAL STORAGE UNITS (U.S. CLS. 2, 12, 13, 14, 23, 25 AND 50).

FIRST USE 1-1-2000; IN COMMERCE 1-1-2000.
AMY HELLA, EXAMINING ATTORNEY



SN 85-260,541. WILLIAMS SCOTSMAN, INC., BALTIMORE, MD. FILED 3-8-2011.

REMOD

THE MARK CONSISTS OF STANDARD CHARACTERS WITHOUT CLAIM TO ANY PARTICULAR FONT, STYLE, SIZE, OR COLOR.

FOR PORTABLE METAL MOBILE OFFICE BUILDINGS THAT ARE RETROFITTED WITH ECO-FRIENDLY MATERIALS AND SYSTEMS; PORTABLE METAL MOBILE OFFICE BUILDINGS THAT ARE RETROFITTED WITH ENERGY EFFICIENT ENHANCEMENTS; PORTABLE METAL MOBILE OFFICE BUILDINGS THAT ARE CUSTOMIZED TO MEET ECO-FRIENDLY AND ENERGY EFFICIENT SPECIFICATIONS OF CUSTOMERS (U.S. CLS. 2, 12, 13, 14, 23, 25 AND 50).

FIRST USE 2-0-2009; IN COMMERCE 12-0-2010.
MICHAEL TANNER, EXAMINING ATTORNEY

CLASS 6—(Continued).

SN 85-271,822. WTEC, FORT LEE, NJ. FILED 3-21-2011.

WTEC

THE MARK CONSISTS OF STANDARD CHARACTERS WITHOUT CLAIM TO ANY PARTICULAR FONT, STYLE, SIZE, OR COLOR.

FOR COMMON METALS AND THEIR ALLOYS, NAMELY, NON-ELECTRIC COPPER AND ALUMINUM CABLES (U.S. CLS. 2, 12, 13, 14, 23, 25 AND 50).

ELLEN BURNS, EXAMINING ATTORNEY



SN 85-275,049. RYAN, JOHN, RANCHO SANTA FE, CA. FILED 3-23-2011.

EMBERARMOR

THE MARK CONSISTS OF STANDARD CHARACTERS WITHOUT CLAIM TO ANY PARTICULAR FONT, STYLE, SIZE, OR COLOR.

FOR METAL ROOF VENTS FOR VENTILATION AND COVERING IN RESIDENTIAL AND COMMERCIAL BUILDINGS; METAL VENT COVERS FOR HVAC DUCTS AND COVERING IN RESIDENTIAL AND COMMERCIAL BUILDINGS (U.S. CLS. 2, 12, 13, 14, 23, 25 AND 50).

FIRST USE 3-12-2011; IN COMMERCE 3-12-2011.
MARLENE BELL, EXAMINING ATTORNEY



SN 85-275,166. MGP MANUFACTURING, HO HO KUS, NJ. FILED 3-23-2011.

Gutter Love

THE MARK CONSISTS OF STANDARD CHARACTERS WITHOUT CLAIM TO ANY PARTICULAR FONT, STYLE, SIZE, OR COLOR.

NO CLAIM IS MADE TO THE EXCLUSIVE RIGHT TO USE "GUTTER", APART FROM THE MARK AS SHOWN.

FOR METAL DEBRIS GUARDS FOR GUTTERS (U.S. CLS. 2, 12, 13, 14, 23, 25 AND 50).

RUDY R. SINGLETON, EXAMINING ATTORNEY

CLASS 6—(Continued).

SN 85-275,825. MARATHON VALVE, HOUSTON, TX. FILED 3-24-2011.

GUARDIAN

THE MARK CONSISTS OF STANDARD CHARACTERS WITHOUT CLAIM TO ANY PARTICULAR FONT, STYLE, SIZE, OR COLOR.

FOR METAL PRESSURE RELIEF VALVES, NOT BEING PARTS OF MACHINES, FOR OIL AND GAS DRILLING APPLICATIONS (U.S. CLS. 2, 12, 13, 14, 23, 25 AND 50).

JOHN E. MICHOS, EXAMINING ATTORNEY

SN 85-276,069. PANDUIT, TINLEY PARK, IL. FILED 3-24-2011.

FREE-FLO

THE MARK CONSISTS OF STANDARD CHARACTERS WITHOUT CLAIM TO ANY PARTICULAR FONT, STYLE, SIZE, OR COLOR.

FOR METAL VENTILATING EXHAUST DUCTS FOR MOUNTING TO THE TOP OF NETWORK CABINETS (U.S. CLS. 2, 12, 13, 14, 23, 25 AND 50).

GEOFFREY FOSDICK, EXAMINING ATTORNEY

SN 85-277,891. MARATHON VALVE, HOUSTON, TX. FILED 3-26-2011.

SEAL GUARD

THE MARK CONSISTS OF STANDARD CHARACTERS WITHOUT CLAIM TO ANY PARTICULAR FONT, STYLE, SIZE, OR COLOR.

NO CLAIM IS MADE TO THE EXCLUSIVE RIGHT TO USE "SEAL", APART FROM THE MARK AS SHOWN.

FOR ABRASIVE RESISTANT METAL OR PLASTIC INSERTS THAT PROTECT SEALS FROM ABRASION, SOLD AS A COMPONENT OF METAL PRESSURE RELIEF VALVES (U.S. CLS. 2, 12, 13, 14, 23, 25 AND 50).

JOHN E. MICHOS, EXAMINING ATTORNEY

CLASS 6—(Continued).

SN 85-277,916. MARATHON VALVE, HOUSTON, TX. FILED 3-26-2011.

MARATHON VALVE

THE MARK CONSISTS OF STANDARD CHARACTERS WITHOUT CLAIM TO ANY PARTICULAR FONT, STYLE, SIZE, OR COLOR.

NO CLAIM IS MADE TO THE EXCLUSIVE RIGHT TO USE "VALVE", APART FROM THE MARK AS SHOWN.

FOR METAL FLUID HANDLING VALVES FOR OIL AND GAS EXPLORATION AND PROCESSING, NAMELY, SAFETY RELIEF VALVES, FLOAT VALVES, GATE VALVES, CHOKE VALVES, AND BUTTERFLY VALVES, NOT BEING PARTS OF MACHINES (U.S. CLS. 2, 12, 13, 14, 23, 25 AND 50).

JOHN E. MICHOS, EXAMINING ATTORNEY

SN 85-287,099. U.S. BROWN BEAR, INC., DBA U.S. BROWN BEAR, OAKLAND, CA. FILED 4-5-2011.



NO CLAIM IS MADE TO THE EXCLUSIVE RIGHT TO USE "U.S." AND "GROUP", APART FROM THE MARK AS SHOWN.

THE COLOR(S) BROWN AND WHITE IS/ARE CLAIMED AS A FEATURE OF THE MARK.

WORDING "U.S. BROWN BEAR" UNDERLINED AND "EXCEL GROUP" IN WHITE LETTERING ENCASED IN A BROWN RECTANGLE, PLACED UNDERNEATH AN IMAGE OF A BROWN BEAR. THE BEAR IS FACING LEFT AND SEEMS AS IF IT IS IN MID-STEP.

FOR METAL AUDIO, VIDEO AND COMPUTER WALL AND CEILING MOUNTS (U.S. CLS. 2, 12, 13, 14, 23, 25 AND 50).

FIRST USE 7-12-2010; IN COMMERCE 7-15-2010.

CYNTHIA SLOAN, EXAMINING ATTORNEY

CLASS 6—(Continued).

SN 85-289,673. HARGER, MARK, COLORADO SPRINGS, CO. FILED 4-7-2011.

Screllis "The Screen of Green Trellis"

THE MARK CONSISTS OF STANDARD CHARACTERS WITHOUT CLAIM TO ANY PARTICULAR FONT, STYLE, SIZE, OR COLOR.

NO CLAIM IS MADE TO THE EXCLUSIVE RIGHT TO USE "GREEN TRELLIS", APART FROM THE MARK AS SHOWN.

FOR METAL GARDEN STAKES (U.S. CLS. 2, 12, 13, 14, 23, 25 AND 50).

TEJBIR SINGH, EXAMINING ATTORNEY

CLASS 6—(Continued).

SN 85-293,315. HINGEWORX, LLC, SANDY, UT. FILED 4-12-2011.

HINGEWORX

THE MARK CONSISTS OF STANDARD CHARACTERS WITHOUT CLAIM TO ANY PARTICULAR FONT, STYLE, SIZE, OR COLOR.

FOR METAL HINGES (U.S. CLS. 2, 12, 13, 14, 23, 25 AND 50).

WON TEAK OH, EXAMINING ATTORNEY

SN 85-292,047. VALMONT INDUSTRIES, INC., OMAHA, NE. FILED 4-11-2011.

HSS Superstruct

THE MARK CONSISTS OF STANDARD CHARACTERS WITHOUT CLAIM TO ANY PARTICULAR FONT, STYLE, SIZE, OR COLOR.

NO CLAIM IS MADE TO THE EXCLUSIVE RIGHT TO USE "HSS", APART FROM THE MARK AS SHOWN.

FOR METAL TUBING (U.S. CLS. 2, 12, 13, 14, 23, 25 AND 50).

FIRST USE 12-31-2010; IN COMMERCE 12-31-2010.
ARETHA SOMERVILLE, EXAMINING ATTORNEY

SN 85-295,548. PEERLESS INDUSTRIES, INC., AURORA, IL. FILED 4-14-2011.

peerless-AV

OWNER OF U.S. REG. NOS. 1,662,187 AND 3,648,907.
THE COLOR(S) RED IS/ARE CLAIMED AS A FEATURE OF THE MARK.

THE MARK CONSISTS OF THE WORDING "PEERLESS-AV" WITH "PEERLESS" IN RED STYLIZED LETTERS AND "-AV" IN RED OUTLINE STYLIZED LETTERS. WHITE SERVES AS BACKGROUND ONLY AND IS NOT CLAIMED AS A FEATURE OF THE MARK.

FOR METAL AUDIO AND VIDEO WALL AND CEILING MOUNTS FOR AUDIO-VISUAL, PHOTOGRAPHIC AND COMPUTER APPARATUS AND INSTRUMENTS (U.S. CLS. 2, 12, 13, 14, 23, 25 AND 50).

MATTHEW MCDOWELL, EXAMINING ATTORNEY

SN 85-292,272. TREE ISLAND WIRE (USA), INC., WALNUT, CA. FILED 4-11-2011.

KWIK ARCH

THE MARK CONSISTS OF STANDARD CHARACTERS WITHOUT CLAIM TO ANY PARTICULAR FONT, STYLE, SIZE, OR COLOR.

NO CLAIM IS MADE TO THE EXCLUSIVE RIGHT TO USE "ARCH", APART FROM THE MARK AS SHOWN.

FOR GALVANIZED WIRE EXTERIOR RIGHT ANGLE FOR ARCHES AND CURVES CORNER REINFORCING (U.S. CLS. 2, 12, 13, 14, 23, 25 AND 50).

FIRST USE 8-0-1985; IN COMMERCE 8-0-1985.
DEIRDRE ROBERTSON, EXAMINING ATTORNEY

SN 85-307,920. TREE ISLAND WIRE (USA), INC., WALNUT, CA. FILED 4-28-2011.

ZINGGUARD

THE MARK CONSISTS OF STANDARD CHARACTERS WITHOUT CLAIM TO ANY PARTICULAR FONT, STYLE, SIZE, OR COLOR.

FOR GALVANIZED BULK AND COLLATED NAILS (U.S. CLS. 2, 12, 13, 14, 23, 25 AND 50).

DEIRDRE ROBERTSON, EXAMINING ATTORNEY

CLASS 7—MACHINERY

SN 77-149,743. Q.E.P. CO., INC., BOCA RATON, FL. FILED 4-5-2007.



THE MARK CONSISTS OF A SPIDER WITH A DIAMOND IN ITS CENTER AND THE WORDS "BLACK WIDOW" WRITTEN ACROSS.

FOR CIRCULAR DIAMOND SAW BLADES FOR POWER SAWS FOR USE BY TILE INSTALLERS IN CUTTING TILE (U.S. CLS. 13, 19, 21, 23, 31, 34 AND 35).
SANI KHOURI, EXAMINING ATTORNEY

SN 77-666,210. AGRI-FAB, INC., SULLIVAN, IL. FILED 2-9-2009.

SMARTVAC

THE MARK CONSISTS OF STANDARD CHARACTERS WITHOUT CLAIM TO ANY PARTICULAR FONT, STYLE, SIZE, OR COLOR.

FOR LAWN VACUUMS (U.S. CLS. 13, 19, 21, 23, 31, 34 AND 35).
ELLEN PERKINS, EXAMINING ATTORNEY

SN 77-966,890. IOFINA NATURAL GAS, INC., GREENWOOD VILLAGE, CO. FILED 3-24-2010.

POD CLUSTER WET

THE MARK CONSISTS OF STANDARD CHARACTERS WITHOUT CLAIM TO ANY PARTICULAR FONT, STYLE, SIZE, OR COLOR.

FOR PORTABLE, SELF-CONTAINED, IODINE EXTRACTING MACHINES FOR CHEMICAL PROCESSING; PORTABLE SELF-CONTAINED IODINE EXTRACTION UNITS (U.S. CLS. 13, 19, 21, 23, 31, 34 AND 35).
KEVON CHISOLM, EXAMINING ATTORNEY

CLASS 7—(Continued).

SN 79-088,062. TAKRAF GMBH, FED REP GERMANY, FILED 5-4-2010.

TMCS

THE MARK CONSISTS OF STANDARD CHARACTERS WITHOUT CLAIM TO ANY PARTICULAR FONT, STYLE, SIZE, OR COLOR.

PRIORITY DATE OF 11-6-2009 IS CLAIMED.
OWNER OF INTERNATIONAL REGISTRATION 1053054 DATED 5-4-2010, EXPIRES 5-4-2020.

FOR MACHINES, NAMELY, MECHANICAL DEVICES AND EQUIPMENT FOR CONVEYING AND PROCESSING RAW MATERIALS, MAINLY COMPRISING LOADING MACHINES, MOBILE TRANSFER CONVEYORS, BELT CONVEYORS, CONVEYOR BRIDGES AND MOBILE CONVEYOR BRIDGES; MOBILE AND SEMI-MOBILE CRUSHING SYSTEMS FOR COMMUNUTING RAW MATERIALS, MAINLY COMPRISING MACHINES IN THE NATURE OF TRANSPORT CRAWLERS, MECHANICAL RECEIVING HOPPERS, APRON CONVEYORS, CRUSHING MACHINES AND DISCHARGE CONVEYORS OR PIVOTING STACKER BELT CONVEYORS; BELT CONVEYORS, APRON FEEDERS, SLOPE CONVEYORS AND STEEP INCLINE CONVEYORS, ALL BEING MACHINES FOR HANDLING BULK MATERIALS (U.S. CLS. 13, 19, 21, 23, 31, 34 AND 35).

JOHN GARTNER, EXAMINING ATTORNEY

SN 79-091,056. LINDAUER DORNIER GMBH, 88131 LINDAU, FED REP GERMANY, FILED 9-7-2010.

DORNIER

zerotwist

OWNER OF INTERNATIONAL REGISTRATION 0556014 DATED 7-31-1990, EXPIRES 7-31-2020.

OWNER OF U.S. REG. NOS. 2,165,179, 2,183,349 AND 3,595,061.

THE MARK CONSISTS OF THE STYLIZED WORDING "DORNIER ZEROTWIST", WITH THE WORD "DORNIER" APPEARING IN UPPERCASE LETTERS ABOVE THE WORD "ZEROTWIST" IN LOWERCASE LETTERS, AND WITH A HORIZONTAL LINE SEPARATING THE WORDS.

FOR WEAVING MACHINES; SHUTTLE WEAVING MACHINES; FITTINGS FOR WEAVING MACHINES AND FOR SHUTTLE WEAVING MACHINES, NAMELY, FILLING WINDERS AND YARN TENSIONING DEVICES (U.S. CLS. 13, 19, 21, 23, 31, 34 AND 35).

CYNTHIA TRIPI, EXAMINING ATTORNEY

CLASS 7—(Continued).

SN 79-091,957. KONEKS DIS TICARET ANONIM SIRKETI, TURKEY, FILED 8-4-2010.

PRIORITY DATE OF 4-1-2010 IS CLAIMED.
OWNER OF INTERNATIONAL REGISTRATION 1063387 DATED 8-4-2010, EXPIRES 8-4-2020.

THE COLOR(S) BLACK AND YELLOW IS/ARE CLAIMED AS A FEATURE OF THE MARK.

THE MARK CONSISTS OF THE WORD "KONEKS" WRITTEN IN CAPITAL LETTERS AND THE LETTERS "KON" HAVE BEEN WRITTEN INSIDE OF SEPARATE BLACK CIRCLES IN YELLOW COLOR. THE LETTERS "EKS" ARE IN BLACK.

FOR PARTS OF MACHINES AND ENGINES, NAMELY, PISTONS; PISTON SEGMENTS FOR ENGINES AND MACHINE; PISTONS FOR ENGINE CYLINDERS; PISTONS FOR ENGINES; ENGINE PISTON SLEEVES (U.S. CLS. 13, 19, 21, 23, 31, 34 AND 35).
JULIE WATSON, EXAMINING ATTORNEY

SN 79-093,097. DEKOMTE KOMPENSATOR-TECHNIK GMBH, 63500 SELIGENSTADT, FED REP GERMANY, FILED 12-1-2010.

OWNER OF INTERNATIONAL REGISTRATION 0705673 DATED 12-2-1998, EXPIRES 12-2-2018.

THE COLOR(S) RED, GREY, AND BLUE IS/ARE CLAIMED AS A FEATURE OF THE MARK.

THE MARK CONSISTS OF A DESIGN COMPRISED OF THREE CURVED LINES WITH A LONG CURVED LINE IN THE CENTER AND A SMALLER CURVED LINE UNDERNEATH EACH END OF THE CENTER CURVED LINE. THE WORD "DEKOMTE" APPEARS BELOW THE DESIGN WITH "KOM" APPEARING IN BOLD LETTERS. THE COLOR RED APPEARS IN THE LONG CURVED LINE IN THE CENTER. THE COLOR GREY APPEARS IN EACH SMALLER CURVED LINE. THE COLOR BLUE APPEARS IN THE WORDING IN THE MARK. THE WHITE IN THE DRAWING REPRESENTS BACKGROUND AREAS ONLY AND IS NOT PART OF THE MARK.

FOR COMPENSATOR MACHINES FOR THERMAL ENGINEERING, NAMELY, BELLWS (U.S. CLS. 13, 19, 21, 23, 31, 34 AND 35).
MAUREEN DALL, EXAMINING ATTORNEY

CLASS 7—(Continued).

SN 79-095,323. SANDVIK INTELLECTUAL PROPERTY AB, SWEDEN, FILED 1-17-2011.

SANDVIK SANCOAT

THE MARK CONSISTS OF STANDARD CHARACTERS WITHOUT CLAIM TO ANY PARTICULAR FONT, STYLE, SIZE, OR COLOR.

PRIORITY DATE OF 10-12-2010 IS CLAIMED.
OWNER OF INTERNATIONAL REGISTRATION 1071825 DATED 1-17-2011, EXPIRES 1-17-2021.

OWNER OF U.S. REG. NOS. 1,097,910, 3,605,234 AND OTHERS.

THE ENGLISH TRANSLATION OF THE FOREIGN WORD(S) IN THE MARK IS "SANDVIK" CAN BE TRANSLATED AS "SANDY BAY".

FOR COATING BLADES FOR USE IN PAPER MACHINES AND PACKAGING MACHINES (U.S. CLS. 13, 19, 21, 23, 31, 34 AND 35).

SEAN CROWLEY, EXAMINING ATTORNEY

SN 79-097,269. SCHENCK ROTEC GMBH, FED REP GERMANY, FILED 4-13-2011.

THE MARK CONSISTS OF STANDARD CHARACTERS WITHOUT CLAIM TO ANY PARTICULAR FONT, STYLE, SIZE, OR COLOR.

PRIORITY DATE OF 10-14-2010 IS CLAIMED.
OWNER OF INTERNATIONAL REGISTRATION 1076795 DATED 4-13-2011, EXPIRES 4-13-2021.

FOR BALANCING MACHINES FOR ROTORS, IN PARTICULAR DISC-SHAPED ROTORS, AND PARTS OF THE AFOREMENTIONED MACHINES (U.S. CLS. 13, 19, 21, 23, 31, 34 AND 35).

TOBY BULLOFF, EXAMINING ATTORNEY

SN 79-097,320. BÖHMER GMBH, FED REP GERMANY, FILED 2-14-2011.

OWNER OF INTERNATIONAL REGISTRATION 1076924 DATED 2-14-2011, EXPIRES 2-14-2021.

THE MARK CONSISTS OF THE WORDING "BOHMER" IN STYLIZED FONT WITH A DIAMOND DESIGN OVER THE "B" AND AN UMLAUT OVER THE "O".

FOR BALL VALVES BEING PARTS OF MACHINES; BALL VALVES BEING PARTS OF MACHINES AS SHUT-OFF DEVICES IN METAL AND PLASTIC TUBES; PNEUMATIC BALL VALVE ACTUATORS; HYDRAULIC BALL VALVE ACTUATORS (U.S. CLS. 13, 19, 21, 23, 31, 34 AND 35).

DANIEL CAPSHAW, EXAMINING ATTORNEY

CLASS 7—(Continued).

SN 85-054,796. PERRY, LENORE, LEO, IN. AND KING, KEN, LEO, IN. FILED 6-4-2010.



OWNER OF U.S. REG. NOS. 2,109,094, 2,858,493 AND OTHERS.

NO CLAIM IS MADE TO THE EXCLUSIVE RIGHT TO USE "GROOVE", APART FROM THE MARK AS SHOWN.

THE MARK CONSISTS OF THE WORDING "FORM A" OVER THE WORD "GROOVE"; THE WORD "GROOVE" IS INSIDE A RECTANGULAR SHAPE WHERE THE TOP OF THE RECTANGLE FOLLOWS THE SHAPE OF THE WORDING OVER IT.

FOR POWER TOOLS, NAMELY, INSERTS FOR METAL-WORKING MACHINES, POWER OPERATED CUTTING TOOLS AND POWER OPERATED GROOVING TOOLS; MACHINE PARTS, NAMELY BORING BARS AND HOLDERS FOR METAL-WORKING MACHINES (U.S. CLS. 13, 19, 21, 23, 31, 34 AND 35).

GINA HAYES, EXAMINING ATTORNEY

SN 85-117,180. FLODESIGN WIND TURBINE CORPORATION, WILBRAHAM, MA. FILED 8-27-2010.

FLODESIGN WATER TURBINE

THE MARK CONSISTS OF STANDARD CHARACTERS WITHOUT CLAIM TO ANY PARTICULAR FONT, STYLE, SIZE, OR COLOR.

NO CLAIM IS MADE TO THE EXCLUSIVE RIGHT TO USE "WATER TURBINE", APART FROM THE MARK AS SHOWN.

FOR WATER TURBINES (U.S. CLS. 13, 19, 21, 23, 31, 34 AND 35).

CIMMERIAN COLEMAN, EXAMINING ATTORNEY

SN 85-121,993. SEARS BRANDS, LLC, HOFFMAN ESTATES, IL. FILED 9-2-2010.

SWIVEL+ STEERING SYSTEM

THE MARK CONSISTS OF STANDARD CHARACTERS WITHOUT CLAIM TO ANY PARTICULAR FONT, STYLE, SIZE, OR COLOR.

NO CLAIM IS MADE TO THE EXCLUSIVE RIGHT TO USE "SWIVEL" AND "STEERING SYSTEM", APART FROM THE MARK AS SHOWN.

FOR VACUUM CLEANERS (U.S. CLS. 13, 19, 21, 23, 31, 34 AND 35).

JOHN HWANG, EXAMINING ATTORNEY

CLASS 7—(Continued).

SN 85-126,235. RICHARD FRAILEY, ALTUS, OK. FILED 9-9-2010.

BRUSHOPPER

THE MARK CONSISTS OF STANDARD CHARACTERS WITHOUT CLAIM TO ANY PARTICULAR FONT, STYLE, SIZE, OR COLOR.

FOR HARVESTING MACHINES, NAMELY, WOOD AND BRUSH CHIPPING, GRINDING AND GATHERING MACHINES (U.S. CLS. 13, 19, 21, 23, 31, 34 AND 35).

LINDA POWELL, EXAMINING ATTORNEY

SN 85-127,911. BREAT, S.L., 08850 GAVA (BARCELONA), SPAIN, FILED 9-13-2010.

BREAT

THE MARK CONSISTS OF STANDARD CHARACTERS WITHOUT CLAIM TO ANY PARTICULAR FONT, STYLE, SIZE, OR COLOR.

OWNER OF ERPN CMNTY TM OFC REG. NO. 002738359, DATED 11-2-2004, EXPIRES 11-6-2012.

THE WORDING "BREAT" HAS NO MEANING IN A FOREIGN LANGUAGE.

FOR MACHINES FOR MANUFACTURING STRUCTURES IN THE NATURE OF WAX HONEYCOMBS BY SOLIDIFYING A FLUID COMPOUND TO CONFORM TO A SHAPE OF A MOLD; MACHINES FOR MANUFACTURING STRUCTURES IN THE NATURE OF WAX HONEYCOMBS BY SOLIDIFYING A FLUID COMPOUND TO CONFORM TO A SHAPE OF A MOLD, AND MACHINE PARTS, NAMELY, MOLDS FOR WAX MOLDING, ALL FOR USE IN THE MANUFACTURE OF WAX HONEYCOMBS FOR APICULTURE (U.S. CLS. 13, 19, 21, 23, 31, 34 AND 35).

NELSON SNYDER, EXAMINING ATTORNEY

CLASS 7—(Continued).

SN 85-137,210. BROOKS AUTOMATION, INC., CHELMSFORD, MA. FILED 9-24-2010.

RADIANT

THE MARK CONSISTS OF STANDARD CHARACTERS WITHOUT CLAIM TO ANY PARTICULAR FONT, STYLE, SIZE, OR COLOR.

FOR TOOL PLATFORMS IN THE NATURE OF TRANSPORT SYSTEMS FOR SUBSTRATES COMPRISED PRIMARILY OF INDUSTRIAL TRANSPORT ROBOTS AND CHAMBERS CONTAINING AN ISOLATED ENVIRONMENT, SOLD TO OEMS OF AUTOMATED MANUFACTURING SYSTEMS, WHICH PLATFORMS ARE COMBINED BY THE OEMS WITH TOOLS TO CREATE THE AUTOMATED MANUFACTURING SYSTEMS USED IN THE MANUFACTURE OF INTEGRATED CIRCUITS, SEMICONDUCTOR, LED AND OLED DEVICES (U.S. CLS. 13, 19, 21, 23, 31, 34 AND 35).

JANICE L. MCMORROW, EXAMINING ATTORNEY

SN 85-138,426. HYGINIX LLC, SAN DIEGO, CA. FILED 9-26-2010.

THE MISSING SINK

THE MARK CONSISTS OF STANDARD CHARACTERS WITHOUT CLAIM TO ANY PARTICULAR FONT, STYLE, SIZE, OR COLOR.

FOR ELECTRIC WASHING MACHINES FOR INDUSTRIAL PURPOSES (U.S. CLS. 13, 19, 21, 23, 31, 34 AND 35).

LINDA E. BLOHM, EXAMINING ATTORNEY

SN 85-143,821. SONY CORPORATION, TOKYO, JAPAN, FILED 10-3-2010.

SICOPS

THE MARK CONSISTS OF STANDARD CHARACTERS WITHOUT CLAIM TO ANY PARTICULAR FONT, STYLE, SIZE, OR COLOR.

FOR INJECTION MOLDING MACHINES (U.S. CLS. 13, 19, 21, 23, 31, 34 AND 35).

DORITT L. CARROLL, EXAMINING ATTORNEY

CLASS 7—(Continued).

SN 85-147,362. BC EXTRUSION HOLDING GMBH, BAD OEYNHAUSEN, FED REP GERMANY, FILED 10-7-2010.

battenfeld-cincinnati 

THE COLOR(S) ANTHRACITE AND GREEN IS/ARE CLAIMED AS A FEATURE OF THE MARK.

THE MARK CONSISTS OF THE LITERAL ELEMENT "BATTENFELD-CINCINNATI" APPEARING IN A SANS-SERIF FONT TYPE IN ANTHRACITE COLOR. ON THE RIGHT SIDE, THERE ARE FIVE LEAF-SHAPED MOTIFS, ONE OF WHICH SURROUNDS THE LAST TWO LETTERS "TI". THE LEAVES ARE DEPICTED IN COLOR GREEN.

FOR PLASTIC PROCESSING MACHINES, NAMELY, EXTRUDERS, BLOW MOLDING MACHINES, FILM BLOWING MACHINES, FILM EXTRUSION MACHINES, FILM CASTING MACHINES, INJECTION MOLDING MACHINES, DIE-CASTING MACHINES, AND REPLACEMENT PARTS FOR THE AFORESAID MACHINES; MECHANICALLY-OPERATED TOOLS FOR THE AFORESAID MACHINES, NAMELY, POWER DRILLS; MECHANICALLY-OPERATED ACCESSORIES FOR THE AFORESAID MACHINES, NAMELY, AUTOMATIC HANDLING SYSTEMS COMPRISED PRIMARILY OF CONVEYOR BELTS, MATERIAL CONVEYOR DEVICES IN THE NATURE OF CONVEYOR BELTS, CONVEYOR BELT SYSTEMS COMPRISED PRIMARILY OF CONVEYOR BELTS, TOOL CHANGE SYSTEMS COMPRISED PRIMARILY OF CONVEYOR BELTS, TOOL TRANSPORT SYSTEMS COMPRISED PRIMARILY OF CONVEYOR BELTS; FOLLOW-UP EQUIPMENT FOR THE AFORESAID MACHINES, NAMELY, CUTTING OFF DEVICES IN THE NATURE OF POWER OPERATED SAWS, DRAWING DEVICES IN THE NATURE OF WIRE DRAWING MACHINES, AND WINDERS IN THE NATURE OF YARN WINDING MACHINES (U.S. CLS. 13, 19, 21, 23, 31, 34 AND 35).

SEAN CROWLEY, EXAMINING ATTORNEY

SN 85-172,146. WINTER EQUIPMENT COMPANY, INC., WILLOUGHBY, OH. FILED 11-9-2010.

RAZOR

THE MARK CONSISTS OF STANDARD CHARACTERS WITHOUT CLAIM TO ANY PARTICULAR FONT, STYLE, SIZE, OR COLOR.

FOR SPECIALLY ADAPTED PARTS FOR SNOW PLOWS, COMMERCIAL PLOWS, HIGHWAY PLOWS, AND ROAD GRADING MACHINERY IN THE NATURE OF EDGE GUARDS, BLADE WEAR GUARDS, AND MOLDBOARD SHOES; ALL OF THE AFOREMENTIONED NOT FOR USE IN CONNECTION WITH ALL-TERRAIN VEHICLES OR ACCESSORIES THEREFOR (U.S. CLS. 13, 19, 21, 23, 31, 34 AND 35).

FIRST USE 6-1-2009; IN COMMERCE 6-1-2009.

GENE MACIOL, EXAMINING ATTORNEY

CLASS 7—(Continued).

SN 85-186,605. SEM LIMITED, ORPINGTON, KENT, GREAT BRITAIN, FILED 11-29-2010.

SynchroPitch

THE MARK CONSISTS OF STANDARD CHARACTERS WITHOUT CLAIM TO ANY PARTICULAR FONT, STYLE, SIZE, OR COLOR.

OWNER OF FED REP GERMANY REG. NO. 302009073515, DATED 5-26-2010, EXPIRES 12-31-2019.

FOR ELECTRIC MOTORS, NOT FOR MOTOR VEHICLES, IN PARTICULAR BRUSHLESS, PERMANENT MAGNET SERVO MOTORS (U.S. CLS. 13, 19, 21, 23, 31, 34 AND 35).

SUNG IN, EXAMINING ATTORNEY

SN 85-233,713. GENERAL TOOL, INC., IRVINE, CA. FILED 2-3-2011.

DIAMOND^X

THE MARK CONSISTS OF STANDARD CHARACTERS WITHOUT CLAIM TO ANY PARTICULAR FONT, STYLE, SIZE, OR COLOR.

FOR CUTTING INSTRUMENTS MADE IN WHOLE OR SUBSTANTIAL PART OF DIAMONDS, NAMELY, CUTTING TOOLS, GRINDING TOOLS, GRINDING SAW BLADES, GRINDING CUPS AND GRINDING WHEELS ALL FOR USE WITH POWER MACHINES AND ALL USED TO CUT AND WORK ON METAL AND METALLIC SURFACES (U.S. CLS. 13, 19, 21, 23, 31, 34 AND 35).

FIRST USE 8-1-2009; IN COMMERCE 8-1-2009.
B. PARADEWELAI, EXAMINING ATTORNEY

SN 85-233,762. GENERAL TOOL, INC., IRVINE, CA. FILED 2-3-2011.

THE MARK CONSISTS OF THE WORD "DIAMOND", FOLLOWED BY THE LETTER "X" IN A STYLIZED FORM.

FOR CUTTING INSTRUMENTS MADE IN WHOLE OR SUBSTANTIAL PART OF DIAMONDS, NAMELY, CUTTING TOOLS, GRINDING TOOLS, GRINDING SAW BLADES, GRINDING CUPS AND GRINDING WHEELS ALL FOR USE WITH POWER MACHINES AND ALL USED TO CUT AND WORK ON METAL AND METALLIC SURFACES (U.S. CLS. 13, 19, 21, 23, 31, 34 AND 35).

FIRST USE 8-1-2009; IN COMMERCE 8-1-2009.
B. PARADEWELAI, EXAMINING ATTORNEY

CLASS 7—(Continued).

SN 85-241,866. WALTER MEIER (MANUFACTURING) INC., LAVERGNE, TN. FILED 2-14-2011.

TURBOCONE

THE MARK CONSISTS OF STANDARD CHARACTERS WITHOUT CLAIM TO ANY PARTICULAR FONT, STYLE, SIZE, OR COLOR.

FOR DUST COLLECTING MACHINES FOR INDUSTRIAL AND MANUAL WORKSHOP USE (U.S. CLS. 13, 19, 21, 23, 31, 34 AND 35).

PRISCILLA MILTON, EXAMINING ATTORNEY

SN 85-241,876. WALTER MEIER (MANUFACTURING) INC., LAVERGNE, TN. FILED 2-14-2011.

VORTEX CONE

THE MARK CONSISTS OF STANDARD CHARACTERS WITHOUT CLAIM TO ANY PARTICULAR FONT, STYLE, SIZE, OR COLOR.

FOR DUST COLLECTING MACHINES FOR INDUSTRIAL AND MANUAL WORKSHOP USE (U.S. CLS. 13, 19, 21, 23, 31, 34 AND 35).

PRISCILLA MILTON, EXAMINING ATTORNEY

SN 85-261,164. INDOOR BIOTECHNOLOGIES, INC., CHARLOTTESVILLE, VA. FILED 3-8-2011.

DUSTREAM

THE MARK CONSISTS OF STANDARD CHARACTERS WITHOUT CLAIM TO ANY PARTICULAR FONT, STYLE, SIZE, OR COLOR.

FOR POWER OPERATED DUST COLLECTION AND DUST EXTRACTION DEVICES (U.S. CLS. 13, 19, 21, 23, 31, 34 AND 35).

FIRST USE 6-13-2007; IN COMMERCE 6-13-2007.
KAREN SEVERSON, EXAMINING ATTORNEY

CLASS 7—(Continued).

SN 85-267,009. TYMCO, INC., WACO, TX. FILED 3-15-2011.

hDrive

THE MARK CONSISTS OF STANDARD CHARACTERS WITHOUT CLAIM TO ANY PARTICULAR FONT, STYLE, SIZE, OR COLOR.

FOR HYDRAULIC POWER SYSTEM FOR POWERING A STREET SWEEPER SYSTEM, THE HYDRAULIC POWER SYSTEM COMPRISED OF PUMPS, MOTORS, VALVES, SWITCHES, SENSORS AND ELECTRONIC CONTROLS AND REPLACEMENT PARTS THEREFOR (U.S. CLS. 13, 19, 21, 23, 31, 34 AND 35).

FIRST USE 2-3-2011; IN COMMERCE 2-3-2011.
LOURDES AYALA, EXAMINING ATTORNEY

SN 85-268,771. MAX TOOL, LLC, LA VERNE, CA. FILED 3-16-2011.



NO CLAIM IS MADE TO THE EXCLUSIVE RIGHT TO USE "SNOW", APART FROM THE MARK AS SHOWN.

THE MARK CONSISTS OF THE WORDS "SNOW DEMON" ENCASED IN A RECTANGLE APPEARING TO THE LEFT OF A RUNNING DEVIL.

FOR PORTABLE ELECTRIC AND GASOLINE POWERED SNOW BLOWERS (U.S. CLS. 13, 19, 21, 23, 31, 34 AND 35).

FIRST USE 8-30-2010; IN COMMERCE 8-30-2010.
CHARLES L. JENKINS, EXAMINING ATTORNEY

SN 85-269,428. CIOPPA, RICK, POINT PLEASANT BEACH, NJ. FILED 3-17-2011.

Limitless Energy Company

THE MARK CONSISTS OF STANDARD CHARACTERS WITHOUT CLAIM TO ANY PARTICULAR FONT, STYLE, SIZE, OR COLOR.

NO CLAIM IS MADE TO THE EXCLUSIVE RIGHT TO USE "ENERGY COMPANY", APART FROM THE MARK AS SHOWN.

FOR WINDMILLS FOR GENERATING ELECTRICITY; HYDRO-POWERED TURBINES FOR GENERATING ELECTRICITY (U.S. CLS. 13, 19, 21, 23, 31, 34 AND 35).

SOPHIA S. KIM, EXAMINING ATTORNEY

CLASS 7—(Continued).

SN 85-274,875. REDEXIM B.V., 3702 AC ZEIST, NETHERLANDS, FILED 3-23-2011.

VERTI-BROOM

THE MARK CONSISTS OF STANDARD CHARACTERS WITHOUT CLAIM TO ANY PARTICULAR FONT, STYLE, SIZE, OR COLOR.

OWNER OF U.S. REG. NOS. 1,831,897, 2,995,400 AND OTHERS.

FOR AGRICULTURAL MACHINES, IMPLEMENTS AND EQUIPMENT, NAMELY, MACHINES FOR THE MAINTENANCE OF AGRICULTURAL AND ARTIFICIAL GROUNDS, ARTIFICIAL SPORT FIELDS, MEADOWS AND TURF, FOR BRUSHING, SWEEPING, GROOMING AND STRIPING AGRICULTURAL AND ARTIFICIAL GROUNDS, ARTIFICIAL SPORT FIELDS, MEADOWS AND TURF (U.S. CLS. 13, 19, 21, 23, 31, 34 AND 35).

FIRST USE 0-0-1990; IN COMMERCE 0-0-1990.
TINA BROWN, EXAMINING ATTORNEY

SN 85-279,993. KONGSKILDE INDUSTRIES A/S, SOROE, DENMARK, FILED 3-29-2011.



OWNER OF U.S. REG. NOS. 1,008,742 AND 1,958,512.

THE MARK CONSISTS OF A STYLIZED "H" FOLLOWED BY "HOWARD".

FOR TRACTOR DRAWN AND HAND-CONTROLLED, POWER DRIVEN ROTARY CULTIVATING MACHINES, ALONE AND COMBINED WITH SOWING MACHINES AND/OR CHISEL POINT TINES; CHISEL POINT PLOWS; CROP BALING MACHINES; FORAGE FEEDING MACHINES; SUBSOILERS; AND REPLACEMENT PARTS FOR THE FOREGOING (U.S. CLS. 13, 19, 21, 23, 31, 34 AND 35).

FIRST USE 6-26-1974; IN COMMERCE 1-4-1978.
REGINA DRUMMOND, EXAMINING ATTORNEY

SN 85-290,261. THE GORMAN-RUPP COMPANY, MANSFIELD, OH. FILED 4-8-2011.



OWNER OF U.S. REG. NO. 2,133,114.

THE MARK CONSISTS OF THE TERM "PRIME" ABOVE THE TERMS "AIRE PLUS" WITH THE "A" IN THE TERM "AIRE" REPRESENTED BY A STYLIZED REPRESENTATION OF A PUMP IMPELLER.

FOR CENTRIFUGAL PUMPS (U.S. CLS. 13, 19, 21, 23, 31, 34 AND 35).

FIRST USE 1-31-2011; IN COMMERCE 1-31-2011.
KRISTIN CARLSON, EXAMINING ATTORNEY

CLASS 7—(Continued).

SN 85-290,775. EGRANDBUY, INC, INDUSTRY, CA. FILED 4-8-2011.

ROCKET

THE MARK CONSISTS OF STANDARD CHARACTERS WITHOUT CLAIM TO ANY PARTICULAR FONT, STYLE, SIZE, OR COLOR.

FOR ELECTRIC MOTORS FOR TOYS AND HOBBY MODELS (U.S. CLS. 13, 19, 21, 23, 31, 34 AND 35).

FIRST USE 1-1-2011; IN COMMERCE 1-1-2011.

JANICE L. MCMORROW, EXAMINING ATTORNEY

SN 85-291,317. CYTEC INDUSTRIES INC., WOODLAND PARK, NJ. FILED 4-11-2011.

SODAGUARD

THE MARK CONSISTS OF STANDARD CHARACTERS WITHOUT CLAIM TO ANY PARTICULAR FONT, STYLE, SIZE, OR COLOR.

FOR INDUSTRIAL PUMPS FOR THE PREPARATION AND INTRODUCTION OF A SCALE INHIBITOR INTO THE BAYER PROCESS FOR USE IN THE MINING AND METAL EXTRACTION INDUSTRIES (U.S. CLS. 13, 19, 21, 23, 31, 34 AND 35).

WARREN L. OLANDRIA, EXAMINING ATTORNEY

SN 85-291,356. AMERICAN FAB, INC., TRAVELERS REST, SC. FILED 4-11-2011.

AMADA

THE MARK CONSISTS OF STANDARD CHARACTERS WITHOUT CLAIM TO ANY PARTICULAR FONT, STYLE, SIZE, OR COLOR.

FOR PORTABLE GASOLINE POWERED ELECTRIC GENERATORS, PORTABLE DIESEL POWERED ELECTRIC GENERATORS, PORTABLE PROPANE POWERED ELECTRIC GENERATORS, PORTABLE GASOLINE POWERED TRASH PUMPS, PORTABLE DIESEL POWERED TRASH PUMPS, PORTABLE PROPANE POWERED TRASH PUMPS, PORTABLE GASOLINE POWERED AIR COMPRESSORS, PORTABLE DIESEL POWERED AIR COMPRESSORS, PORTABLE PROPANE POWERED AIR COMPRESSORS, PORTABLE ELECTRIC MOTOR POWERED AIR COMPRESSORS, PORTABLE GASOLINE POWERED PRESSURE WASHERS, PORTABLE DIESEL POWERED PRESSURE WASHERS, PORTABLE PROPANE POWERED PRESSURE WASHERS AND PORTABLE ELECTRIC MOTOR POWERED PRESSURE WASHERS (U.S. CLS. 13, 19, 21, 23, 31, 34 AND 35).

THEODORE MCBRIDE, EXAMINING ATTORNEY

CLASS 7—(Continued).

SN 85-292,299. FILPAC, INC., SALT LAKE CITY, UT. FILED 4-11-2011.



THE MARK CONSISTS OF THE WORD "PUREPRO" WHERE THE LETTER "P" IN "PUREPRO" IS JOINED WITH A SWIRL.

FOR AUTOMOTIVE IGNITION PARTS, NAMELY, DISTRIBUTOR CAPS AND ROTORS, SPARK PLUGS AND IGNITION WIRES, AND CONDENSERS; AUTOMOTIVE BELTS, NAMELY, FAN BELTS; AUTOMOTIVE EMISSION REDUCTION UNITS, NAMELY, PCV VALVES; AUTOMOTIVE FILTERS, NAMELY, OIL FILTERS, AIR FILTERS, FUEL FILTERS AND TRANSMISSION FILTERS (U.S. CLS. 13, 19, 21, 23, 31, 34 AND 35).

FIRST USE 4-1-2004; IN COMMERCE 4-1-2004.

KAPIL BHANOT, EXAMINING ATTORNEY

SN 85-293,079. FLEXICON CORPORATION, BETHLEHEM, PA. FILED 4-12-2011.

BLOCK-BUSTER

THE MARK CONSISTS OF STANDARD CHARACTERS WITHOUT CLAIM TO ANY PARTICULAR FONT, STYLE, SIZE, OR COLOR.

FOR BULK BAG DISCHARGING EQUIPMENT, NAMELY, BULK BAG CONDITIONERS FOR USE IN LOOSENING BULK SOLID MATERIAL THAT HAS SOLIDIFIED DURING STORAGE AND SHIPMENT (U.S. CLS. 13, 19, 21, 23, 31, 34 AND 35).

FIRST USE 4-13-2011; IN COMMERCE 4-13-2011.

GRETTA YAO, EXAMINING ATTORNEY

SN 85-294,619. SKITTER & SQUIRT ADVENTURES, LLC, MISSOULA, MT. FILED 4-13-2011.

DustRam

THE MARK CONSISTS OF STANDARD CHARACTERS WITHOUT CLAIM TO ANY PARTICULAR FONT, STYLE, SIZE, OR COLOR.

FOR AIR POWERED TOOLS, NAMELY, CHIPPING HAMMERS AND DEMOLITION HAMMERS; POWER OPERATED TOOLS, NAMELY, DRILL HAMMERS; POWER TOOL PARTS, NAMELY, CHIPPING HAMMER AND DEMOLITION HAMMER VACUUM ATTACHMENTS; POWER TOOLS, NAMELY, HAMMER DRIVERS; SUCTION NOZZLES FOR VACUUM CLEANERS (U.S. CLS. 13, 19, 21, 23, 31, 34 AND 35).

EMILY CHUO, EXAMINING ATTORNEY

CLASS 7—(Continued).

SN 85-294,908. YASKAWA AMERICA, INC., WAUKEGAN, IL. FILED 4-14-2011.

IQBYPASS

THE MARK CONSISTS OF STANDARD CHARACTERS WITHOUT CLAIM TO ANY PARTICULAR FONT, STYLE, SIZE, OR COLOR.

FOR AC VARIABLE FREQUENCY DRIVES THAT ARE USED TO CONTROL MOTORS FOR HVAC AND BUILDING AUTOMATION APPLICATIONS (U.S. CLS. 13, 19, 21, 23, 31, 34 AND 35).

CARYN GLASSER, EXAMINING ATTORNEY

CLASS 7—(Continued).

SN 85-298,109. ACCESS ENERGY, LLC, YORBA LINDA, CA. FILED 4-18-2011.

PROCORE

THE MARK CONSISTS OF STANDARD CHARACTERS WITHOUT CLAIM TO ANY PARTICULAR FONT, STYLE, SIZE, OR COLOR.

FOR ELECTRICITY GENERATOR CONSISTING OF A WASTE HEAT RECOVERY SYSTEM FOR THE OIL AND GAS INDUSTRY (U.S. CLS. 13, 19, 21, 23, 31, 34 AND 35).

DAVID C. REIHNER, EXAMINING ATTORNEY

SN 85-294,918. YASKAWA AMERICA, INC., WAUKEGAN, IL. FILED 4-14-2011.

iQBYPASS

THE MARK CONSISTS OF THE WORDING "IQBYPASS" WITH A LINE UNDERNEATH.

FOR AC VARIABLE FREQUENCY DRIVES THAT ARE USED TO CONTROL MOTORS FOR HVAC AND BUILDING AUTOMATION APPLICATIONS (U.S. CLS. 13, 19, 21, 23, 31, 34 AND 35).

CARYN GLASSER, EXAMINING ATTORNEY

SN 85-300,275. ORECK HOLDINGS, LLC, NASHVILLE, TN. FILED 4-20-2011.

QUICKSWITCH

THE MARK CONSISTS OF STANDARD CHARACTERS WITHOUT CLAIM TO ANY PARTICULAR FONT, STYLE, SIZE, OR COLOR.

FOR VACUUM CLEANERS (U.S. CLS. 13, 19, 21, 23, 31, 34 AND 35).

MARILYN IZZI, EXAMINING ATTORNEY

SN 85-295,770. ACCESS ENERGY, LLC, YORBA LINDA, CA. FILED 4-14-2011.

ACCESS ENERGY

THE MARK CONSISTS OF STANDARD CHARACTERS WITHOUT CLAIM TO ANY PARTICULAR FONT, STYLE, SIZE, OR COLOR.

FOR ELECTRICITY GENERATOR CONSISTING OF A WASTE HEAT RECOVERY SYSTEM FOR THE OIL AND GAS INDUSTRY (U.S. CLS. 13, 19, 21, 23, 31, 34 AND 35).

DAVID C. REIHNER, EXAMINING ATTORNEY

SN 85-303,690. LG ELECTRONICS INC., SEOUL 150-721, REPUBLIC OF KOREA, FILED 4-25-2011.

INTELLISOAP

THE MARK CONSISTS OF STANDARD CHARACTERS WITHOUT CLAIM TO ANY PARTICULAR FONT, STYLE, SIZE, OR COLOR.

OWNER OF U.S. REG. NO. 2,941,096. FOR CLOTHES WASHING MACHINE (U.S. CLS. 13, 19, 21, 23, 31, 34 AND 35).

DAVID HOFFMAN, EXAMINING ATTORNEY

CLASS 7—(Continued).

SN 85-308,191. WEATHERFORD/LAMB, INC., HOUSTON, TX. FILED 4-29-2011.

ZoneSelect

THE MARK CONSISTS OF STANDARD CHARACTERS WITHOUT CLAIM TO ANY PARTICULAR FONT, STYLE, SIZE, OR COLOR.

FOR OPENHOLE OIL AND GAS WELL COMPLETION SYSTEMS USED IN HYDRAULICALLY FRACTURED MULTI-ZONE WELLS COMPRISED OF PACKERS, SLIDING SLEEVES FOR USE IN THE FLOW OF MATERIALS THROUGHOUT THE WELL, COMPOSITE BRIDGE PLUGS FOR CONTROLLING PRESSURE OR FLUIDS DOWNHOLE, ENGINEERED COMPOSITE BALLS FOR USE IN THE FLOW OF LIQUIDS, HORIZONTAL BALL SEAT VALVES, MECHANICALLY CEMENTED PORTS FOR CONTROLLING PRESSURE DOWNHOLE, AND OPEN HOLE ANCHORS (U.S. CLS. 13, 19, 21, 23, 31, 34 AND 35).

FIRST USE 5-1-2007; IN COMMERCE 5-1-2007.
MATTHEW MCDOWELL, EXAMINING ATTORNEY

SN 85-308,228. WEATHERFORD/LAMB, INC., HOUSTON, TX. FILED 4-29-2011.



NO CLAIM IS MADE TO THE EXCLUSIVE RIGHT TO USE "FRACTURING SYSTEM", APART FROM THE MARK AS SHOWN.

THE COLOR(S) RED, BLACK, WHITE IS/ARE CLAIMED AS A FEATURE OF THE MARK.

THE MARK CONSISTS OF THE WORDING "ZONESELECT FRACTURING SYSTEM" WITH A CAPITAL "Z" IN "ZONE" AND "S" IN "SELECT" BOTH LETTERS ARE RED WITH BLACK SHADOWING AND ARE CONNECTED BY A LINE AT THE BOTTOM. THE REST OF THE WORDING IS COMPRISED OF LOWER CASE BLACK LETTERS WITH A RED OUTLINE. THERE IS A HIGHLY STYLIZED "W" LOGO IN BLACK IN THE UPPER PART OF THE LETTER "Z". THE WORDING "FRACTURING SYSTEM" APPEARS BELOW THE WORD "SELECT" IN SMALLER BLACK LETTERING AND RED TRIM.

FOR OPENHOLE OIL AND GAS WELL COMPLETION SYSTEMS USED IN HYDRAULICALLY FRACTURED MULTI-ZONE WELLS COMPRISED OF PACKERS, SLIDING SLEEVES FOR USE IN THE FLOW OF MATERIALS THROUGHOUT THE WELL, COMPOSITE BRIDGE PLUGS FOR CONTROLLING PRESSURE OR FLUIDS DOWNHOLE, ENGINEERED COMPOSITE BALLS FOR USE IN THE FLOW OF LIQUIDS, HORIZONTAL BALL SEAT VALVES, MECHANICALLY CEMENTED PORTS FOR CONTROLLING PRESSURE DOWNHOLE, AND OPEN HOLE ANCHORS (U.S. CLS. 13, 19, 21, 23, 31, 34 AND 35).

FIRST USE 5-1-2007; IN COMMERCE 5-1-2007.
MATTHEW MCDOWELL, EXAMINING ATTORNEY

CLASS 7—(Continued).

SN 85-310,083. EURO-PRO OPERATING LLC, NEWTON, MA. FILED 5-2-2011.

WELLNESS WARRIOR

THE MARK CONSISTS OF STANDARD CHARACTERS WITHOUT CLAIM TO ANY PARTICULAR FONT, STYLE, SIZE, OR COLOR.

FOR ELECTRIC FOOD BLENDERS FOR DOMESTIC USE AND ELECTRIC FOOD PROCESSORS (U.S. CLS. 13, 19, 21, 23, 31, 34 AND 35).

RUSS HERMAN, EXAMINING ATTORNEY

SN 85-310,833. ORECK HOLDINGS, LLC, NASHVILLE, TN. FILED 5-3-2011.

FOREVER

THE MARK CONSISTS OF STANDARD CHARACTERS WITHOUT CLAIM TO ANY PARTICULAR FONT, STYLE, SIZE, OR COLOR.

FOR VACUUM CLEANERS (U.S. CLS. 13, 19, 21, 23, 31, 34 AND 35).

MARILYN IZZI, EXAMINING ATTORNEY

SN 85-310,848. ORECK HOLDINGS, LLC, NASHVILLE, TN. FILED 5-3-2011.

ORECK FOREVER

THE MARK CONSISTS OF STANDARD CHARACTERS WITHOUT CLAIM TO ANY PARTICULAR FONT, STYLE, SIZE, OR COLOR.

OWNER OF U.S. REG. NOS. 1,454,954, 2,734,838 AND OTHERS.

FOR VACUUM CLEANERS (U.S. CLS. 13, 19, 21, 23, 31, 34 AND 35).

MARILYN IZZI, EXAMINING ATTORNEY

CLASS 7—(Continued).

SN 85-319,316. ACCESS ENERGY, LLC, YORBA LINDA, CA. FILED 5-12-2011.



THE MARK CONSISTS OF STYLIZED LETTERS "A" AND "E" WITH ARROWS AT THE TIP OF THE "A" AND "E" AND THE WORDS "ACCESS ENERGY" BELOW.

FOR ELECTRICITY GENERATOR CONSISTING OF A WASTE HEAT RECOVERY SYSTEM FOR THE OIL AND GAS INDUSTRY (U.S. CLS. 13, 19, 21, 23, 31, 34 AND 35).
DAVID C. REIHNER, EXAMINING ATTORNEY

CLASS 8—HAND TOOLS

SN 76-706,498. ARBORJET INC., WOBURN, MA. FILED 2-22-2011.

ARBORplugs

THE MARK CONSISTS OF STANDARD CHARACTERS WITHOUT CLAIM TO ANY PARTICULAR FONT, STYLE, SIZE, OR COLOR.

FOR PLASTIC INSERTS FOR POSITIONING INTO APERTURES DRILLED IN TREES FOR RECEIPT OF THE NEEDLE OF A PLANT INJECTOR (U.S. CLS. 23, 28 AND 44).

FIRST USE 12-0-2007; IN COMMERCE 12-0-2007.
KATHY DE JONGE, EXAMINING ATTORNEY

SN 85-327,473. PRIMESOURCE BUILDING PRODUCTS, INC., IRVING, TX. FILED 5-23-2011.

COMBOPRO

THE MARK CONSISTS OF STANDARD CHARACTERS WITHOUT CLAIM TO ANY PARTICULAR FONT, STYLE, SIZE, OR COLOR.

OWNER OF U.S. REG. NO. 3,870,649.
FOR BITS FOR POWER DRILLS, NAMELY, CORE DRILLING BITS (U.S. CLS. 13, 19, 21, 23, 31, 34 AND 35).
NORA BUCHANAN WILL, EXAMINING ATTORNEY

SN 77-940,448. THANE INTERNATIONAL, INC., LA QUINTA, CA. FILED 2-19-2010.

GO! GO! NAILS

THE MARK CONSISTS OF STANDARD CHARACTERS WITHOUT CLAIM TO ANY PARTICULAR FONT, STYLE, SIZE, OR COLOR.

NO CLAIM IS MADE TO THE EXCLUSIVE RIGHT TO USE "NAILS", APART FROM THE MARK AS SHOWN.
FOR ELECTRIC MANICURE SETS; PEDICURE SETS (U.S. CLS. 23, 28 AND 44).

WANDA KAY PRICE, EXAMINING ATTORNEY

SN 85-341,870. FLEXICON CORPORATION, BETHLEHEM, PA. FILED 6-9-2011.

FLEXI-FORCE

THE MARK CONSISTS OF STANDARD CHARACTERS WITHOUT CLAIM TO ANY PARTICULAR FONT, STYLE, SIZE, OR COLOR.

OWNER OF U.S. REG. NOS. 1,048,025, 1,682,650 AND 3,484,984.

FOR BULK MATERIAL HANDLING MACHINES, NAMELY, LUMP BREAKERS (U.S. CLS. 13, 19, 21, 23, 31, 34 AND 35).

GRETTA YAO, EXAMINING ATTORNEY

SN 79-098,309. KONINKLIJKE PHILIPS ELECTRONICS N.V., NETHERLANDS, FILED 5-18-2011.

AQUATOUCHE

THE MARK CONSISTS OF STANDARD CHARACTERS WITHOUT CLAIM TO ANY PARTICULAR FONT, STYLE, SIZE, OR COLOR.

PRIORITY DATE OF 11-23-2010 IS CLAIMED.

OWNER OF INTERNATIONAL REGISTRATION 1079776 DATED 5-18-2011, EXPIRES 5-18-2021.

FOR ELECTRIC SHAVERS, BLADES FOR ELECTRIC SHAVERS (U.S. CLS. 23, 28 AND 44).

JANICE L. MCMORROW, EXAMINING ATTORNEY

CLASS 8—(Continued).

SN 79-098,319. KONINKLIJKE PHILIPS ELECTRONICS N.V.,
NETHERLANDS, FILED 5-5-2011.

POWERTOUCH

THE MARK CONSISTS OF STANDARD CHARACTERS
WITHOUT CLAIM TO ANY PARTICULAR FONT, STYLE,
SIZE, OR COLOR.

PRIORITY DATE OF 11-12-2010 IS CLAIMED.
OWNER OF INTERNATIONAL REGISTRATION 1079814
DATED 5-5-2011, EXPIRES 5-5-2021.
FOR ELECTRIC SHAVERS, BLADES FOR ELECTRIC
SHAVERS (U.S. CLS. 23, 28 AND 44).
JANICE L. MCMORROW, EXAMINING ATTORNEY

SN 85-004,244. PEGATRON CORPORATION, TAIPEI CITY
112, TAIWAN, FILED 4-1-2010.

PEGACASA

PRIORITY CLAIMED UNDER SEC. 44(D) ON TAIWAN
APPLICATION NO. 099012236, FILED 3-19-2010, REG. NO.
01461215, DATED 6-16-2011, EXPIRES 6-15-2021.

THE MARK CONSISTS OF THE WORD "PEGACASA"
WHERE THE LETTERS "PEGA" ARE IN BOLD AND THE
FIRST LETTER "A" DOES NOT HAVE A CROSS BAR.

THE ENGLISH TRANSLATION OF THE "CASA" POR-
TION IN THE MARK IS "HOME".

FOR SCISSORS (U.S. CLS. 23, 28 AND 44).
ALYSSA STEEL, EXAMINING ATTORNEY

SN 85-015,910. NOGENT ***, 52340 BIESLES, FRANCE,
FILED 4-16-2010.

NOGENT PROFILE

THE MARK CONSISTS OF STANDARD CHARACTERS
WITHOUT CLAIM TO ANY PARTICULAR FONT, STYLE,
SIZE, OR COLOR.

PRIORITY CLAIMED UNDER SEC. 44(D) ON FRANCE
APPLICATION NO. 093699308, FILED 12-16-2009, REG. NO.
09/3699308, DATED 12-16-2009, EXPIRES 12-16-2019.

OWNER OF U.S. REG. NO. 3,741,755.
SEC. 2(F) AS TO "NOGENT".
FOR TABLE KNIVES; KITCHEN KNIVES (U.S. CLS.
23, 28 AND 44).
BARBARA A. GOLD, EXAMINING ATTORNEY

CLASS 8—(Continued).

SN 85-048,475. RAZOR MD, LLC, BOYNTON BEACH, FL.
FILED 5-26-2010.

RAZOR MD

THE MARK CONSISTS OF STANDARD CHARACTERS
WITHOUT CLAIM TO ANY PARTICULAR FONT, STYLE,
SIZE, OR COLOR.

NO CLAIM IS MADE TO THE EXCLUSIVE RIGHT TO
USE "RAZOR", APART FROM THE MARK AS SHOWN.

FOR OEM, NAMELY, ORIGINAL EQUIPMENT MAN-
UFACTURED GOODS, NAMELY, RAZORS, GROOM
GIFT KITS COMPOSED OF RAZORS, STANDS FOR
RAZORS, SCISSORS (U.S. CLS. 23, 28 AND 44).

FIRST USE 9-1-2009; IN COMMERCE 9-1-2009.
DEZMONA MIZELLE, EXAMINING ATTORNEY

SN 85-118,828. SMG BRANDS, INC., WILMINGTON, DE.
FILED 8-30-2010.

QUICK PUMP

THE MARK CONSISTS OF STANDARD CHARACTERS
WITHOUT CLAIM TO ANY PARTICULAR FONT, STYLE,
SIZE, OR COLOR.

NO CLAIM IS MADE TO THE EXCLUSIVE RIGHT TO
USE "PUMP", APART FROM THE MARK AS SHOWN.

FOR HAND-OPERATED SPRAYERS FOR PESTI-
CIDES, HERBICIDES, INSECTICIDES, AND FUNGI-
CIDES (U.S. CLS. 23, 28 AND 44).

PAUL MORENO, EXAMINING ATTORNEY

SN 85-121,895. COTY US LLC, NEW YORK, NY. FILED 9-2-
2010.

MIGHTY MINI

THE MARK CONSISTS OF STANDARD CHARACTERS
WITHOUT CLAIM TO ANY PARTICULAR FONT, STYLE,
SIZE, OR COLOR.

NO CLAIM IS MADE TO THE EXCLUSIVE RIGHT TO
USE "MINI", APART FROM THE MARK AS SHOWN.

FOR PERSONAL CARE IMPLEMENTS, NAMELY,
TWEEZERS (U.S. CLS. 23, 28 AND 44).

MATTHEW MCDOWELL, EXAMINING ATTORNEY

CLASS 8—(Continued).

SN 85-181,992. KOMAR COSMETICS (GUANGZHOU) LTD., GUANGZHOU, CHINA, FILED 11-21-2010.



NO CLAIM IS MADE TO THE EXCLUSIVE RIGHT TO USE "SCISSORS", APART FROM THE MARK AS SHOWN.

THE COLOR(S) RED, WHITE AND BLACK IS/ARE CLAIMED AS A FEATURE OF THE MARK.

THE MARK CONSISTS OF THE WORD "TSUBAME" IN BLACK COLOR, THE WORD "SCISSORS" IN RED COLOR ABOVE, AND A RED CIRCULAR DEVICE WITH A WHITE BIRD ON THE LEFT.

THE ENGLISH TRANSLATION OF "TSUBAME" IN THE MARK IS "SWALLOW".

FOR BLADES AND BRUSHES FOR ELECTRIC HAIR CLIPPERS AND TRIMMERS; ELECTRIC MANICURE SETS; HAIR CLIPPERS; HAIR CUTTING SCISSORS; HAIR TRIMMERS; MANICURE SETS; MUSTACHE AND BEARD TRIMMERS; NAIL CLIPPERS; NON-ELECTRIC CURLING IRONS; RAZOR BLADES (U.S. CLS. 23, 28 AND 44).

DAVID TOOLEY, EXAMINING ATTORNEY

SN 85-183,551. PERMA BRANDS CORPORATION, TORONTO, ONTARIO, CANADA, FILED 11-23-2010.

RAZORPIT

THE MARK CONSISTS OF STANDARD CHARACTERS WITHOUT CLAIM TO ANY PARTICULAR FONT, STYLE, SIZE, OR COLOR.

PRIORITY CLAIMED UNDER SEC. 44(D) ON CANADA APPLICATION NO. 1,482,887, FILED 5-28-2010.

OWNER OF CANADA REG. NO. TMA799822, DATED 6-13-2011, EXPIRES 6-13-2026.

FOR RAZOR BLADE CLEANING AND SHARPENING DEVICE (U.S. CLS. 23, 28 AND 44).

HENRY S. ZAK, EXAMINING ATTORNEY

CLASS 8—(Continued).

SN 85-240,190. SUMMIT TOOL COMPANY, DBA KEN-TOOL, AKRON, OH. FILED 2-11-2011.

BLUE COBRA

THE MARK CONSISTS OF STANDARD CHARACTERS WITHOUT CLAIM TO ANY PARTICULAR FONT, STYLE, SIZE, OR COLOR.

NO CLAIM IS MADE TO THE EXCLUSIVE RIGHT TO USE "BLUE", APART FROM THE MARK AS SHOWN.

FOR HAND TOOLS, NAMELY, TRUCK TIRE DEMOUNT BARS FOR DEMOUNTING TRUCK TIRES FROM THEIR WHEELS (U.S. CLS. 23, 28 AND 44).

FIRST USE 3-22-2010; IN COMMERCE 3-22-2010.

SIMON TENG, EXAMINING ATTORNEY

SN 85-249,159. CLIO DESIGNS INCORPORATED, WALTHAM, MA. FILED 2-23-2011.

BEAUTYTRIM

THE MARK CONSISTS OF STANDARD CHARACTERS WITHOUT CLAIM TO ANY PARTICULAR FONT, STYLE, SIZE, OR COLOR.

FOR HAIR TRIMMERS (U.S. CLS. 23, 28 AND 44).

FIRST USE 6-0-2008; IN COMMERCE 9-0-2008.

MATTHEW EINSTEIN, EXAMINING ATTORNEY

SN 85-254,955. TUSCAN LEVELING, INC., FAIRFIELD, IA. FILED 3-1-2011.

WEDGE-TEC

THE MARK CONSISTS OF STANDARD CHARACTERS WITHOUT CLAIM TO ANY PARTICULAR FONT, STYLE, SIZE, OR COLOR.

FOR HAND TOOLS, NAMELY, TILE LEVELERS FOR INSERTION BETWEEN ADJACENT FLOORING TILES AND FLOORING MODULES MADE OF BOTH MAN-MADE AND NATURAL MATERIALS (U.S. CLS. 23, 28 AND 44).

JANET LEE, EXAMINING ATTORNEY

CLASS 8—(Continued).

SN 85-271,091. CREATIVE COMMODITIES, INC., EXETER, RI. FILED 3-18-2011.



NO CLAIM IS MADE TO THE EXCLUSIVE RIGHT TO USE "DRAWSTRING TOOL", APART FROM THE MARK AS SHOWN.

THE MARK CONSISTS OF THE WORDS "DRAWSTRING TOOL" IN A STYLIZED DESIGN WITH THE WORD "THE" POSITIONED THERE ABOVE AND THE WORDS "JUST HOOK IT, PULL IT, AND GO!" POSITIONED THERE BELOW.

FOR HAND TOOLS, NAMELY, A DRAWSTRING FINDING HOOK (U.S. CLS. 23, 28 AND 44).
TRACY CROSS, EXAMINING ATTORNEY

SN 85-275,672. TRIPLE AUGHT DESIGN, LLC, SAN FRANCISCO, CA. FILED 3-24-2011.

TRIPLE AUGHT DESIGN

THE MARK CONSISTS OF STANDARD CHARACTERS WITHOUT CLAIM TO ANY PARTICULAR FONT, STYLE, SIZE, OR COLOR.

OWNER OF U.S. REG. NO. 3,338,705.

NO CLAIM IS MADE TO THE EXCLUSIVE RIGHT TO USE "DESIGN", APART FROM THE MARK AS SHOWN.

FOR KNIVES; MULTI-FUNCTION HAND TOOLS COMPRISED OF TWO OR MORE OF THE FOLLOWING COMPONENTS: CAMPING KNIVES, SURVIVAL KNIVES, KNIFE ADJUSTMENT TOOLS, SCREWDRIVERS, CAN OPENERS, AND BOTTLE OPENERS (U.S. CLS. 23, 28 AND 44).

FIRST USE 2-1-1997; IN COMMERCE 12-31-1997.

JOHN SCHUYLER YARD, EXAMINING ATTORNEY

SN 85-277,170. DARRYL THURNER, SEBASTOPOL, CA. AND DARRYL THURNER, SEBASTOPOL, CA. FILED 3-25-2011.

Hip Buddies

THE MARK CONSISTS OF STANDARD CHARACTERS WITHOUT CLAIM TO ANY PARTICULAR FONT, STYLE, SIZE, OR COLOR.

NO CLAIM IS MADE TO THE EXCLUSIVE RIGHT TO USE "HIP", APART FROM THE MARK AS SHOWN.

FOR TOOL POUCHES FOR ATTACHMENT TO TOOL BELTS (U.S. CLS. 23, 28 AND 44).

FIRST USE 3-18-2011; IN COMMERCE 3-18-2011.

ANTHONY RINKER, EXAMINING ATTORNEY

CLASS 8—(Continued).

SN 85-288,568. STANLEY LOGISTICS, L.L.C., NEW BRITAIN, CT. FILED 4-7-2011.

InstantChange

THE MARK CONSISTS OF STANDARD CHARACTERS WITHOUT CLAIM TO ANY PARTICULAR FONT, STYLE, SIZE, OR COLOR.

FOR KNIVES (U.S. CLS. 23, 28 AND 44).

FIRST USE 12-31-2002; IN COMMERCE 12-31-2002.

GIANCARLO CASTRO, EXAMINING ATTORNEY

SN 85-288,575. STANLEY LOGISTICS, L.L.C., NEW BRITAIN, CT. FILED 4-7-2011.

RB5

THE MARK CONSISTS OF STANDARD CHARACTERS WITHOUT CLAIM TO ANY PARTICULAR FONT, STYLE, SIZE, OR COLOR.

FOR HAND TOOLS, NAMELY, PLANES; REPLACEMENT PARTS FOR HAND-OPERATED PLANES, NAMELY, BLADES, HANDLES AND KNOBS (U.S. CLS. 23, 28 AND 44).

FIRST USE 12-31-1998; IN COMMERCE 12-31-1998.

GIANCARLO CASTRO, EXAMINING ATTORNEY

SN 85-288,580. STANLEY LOGISTICS, L.L.C., NEW BRITAIN, CT. FILED 4-7-2011.

SportUtility

THE MARK CONSISTS OF STANDARD CHARACTERS WITHOUT CLAIM TO ANY PARTICULAR FONT, STYLE, SIZE, OR COLOR.

FOR UTILITY KNIFE; RETRACTABLE UTILITY BLADE (U.S. CLS. 23, 28 AND 44).

FIRST USE 12-31-1999; IN COMMERCE 12-31-1999.

GIANCARLO CASTRO, EXAMINING ATTORNEY

CLASS 8—(Continued).

SN 85-289,723. RONALD W. LAKE, EUGENE, OR. FILED 4-8-2011.

Rapid Response

THE MARK CONSISTS OF STANDARD CHARACTERS WITHOUT CLAIM TO ANY PARTICULAR FONT, STYLE, SIZE, OR COLOR.
FOR CARVING KNIVES; FOLDING KNIVES (U.S. CLS. 23, 28 AND 44).
JORDAN BAKER, EXAMINING ATTORNEY



SN 85-293,590. LEE, PETER, ONTARIO, CA. FILED 4-13-2011.

RONIN

THE MARK CONSISTS OF STANDARD CHARACTERS WITHOUT CLAIM TO ANY PARTICULAR FONT, STYLE, SIZE, OR COLOR.
FOR JAPANESE SWORDS (U.S. CLS. 23, 28 AND 44).
RONALD AIKENS, EXAMINING ATTORNEY



SN 85-293,966. MURATEC-KDS CORP., KYOTO-SHI, KYOTO, JAPAN, FILED 4-13-2011.

JOB BOSS

THE MARK CONSISTS OF STANDARD CHARACTERS WITHOUT CLAIM TO ANY PARTICULAR FONT, STYLE, SIZE, OR COLOR.
FOR HAND TOOLS, NAMELY, UTILITY KNIVES AND BLADES THEREFOR (U.S. CLS. 23, 28 AND 44).
FIRST USE 1-19-1999; IN COMMERCE 1-19-1999.
GINA HAYES, EXAMINING ATTORNEY

CLASS 9—ELECTRICAL AND SCIENTIFIC APPARATUS

SN 76-682,571. PLASTIC LOGIC LIMITED, CAMBRIDGE, CAMBRIDGESHIRE, UNITED KINGDOM, FILED 10-3-2007.

JUST LIKE PAPER

THE MARK CONSISTS OF STANDARD CHARACTERS WITHOUT CLAIM TO ANY PARTICULAR FONT, STYLE, SIZE, OR COLOR.
OWNER OF ERPN CMNTY TM OFC REG. NO. 006390025, DATED 10-23-2008, EXPIRES 10-24-2017.
FOR ANTI GLARE SCREENS FOR COMPUTER MONITORS, COMPUTER SCREENS, IMAGE SCREENS, ANTI-GLARE SCREENS FOR USE WITH COMPUTERS; SCREENS FOR USE WITH VISUAL DISPLAY UNITS; VIDEO DISPLAY SCREENS; ELECTRONIC DEVICES FOR DISPLAYING INFORMATION, NAMELY, FLAT-PANEL DISPLAY SCREENS, LCD MONITORS, PLASMA DISPLAY PANELS; ELECTRONIC DATA PROCESSING DEVICES FOR DISPLAYING INFORMATION, NAMELY, PERSONAL DIGITAL ASSISTANTS; ELECTRONIC DEVICES FOR RECEIVING AND/OR TRANSMITTING DATA THAT IS SUBSEQUENTLY DISPLAYED, NAMELY, PERSONAL DIGITAL ASSISTANTS, MOBILE TELEPHONES; LAPTOPS; PDAS; COMPUTER HARDWARE; COMPUTER SOFTWARE FOR THE PROCESSING OF TEXT, STILL AND MOVING IMAGE PROCESSING (U.S. CLS. 21, 23, 26, 36 AND 38).
FLORENTINA BLANDU, EXAMINING ATTORNEY



SN 76-701,587. SYNCHRONICA PLC, UNITED KINGDOM, FILED 2-16-2010.



NO CLAIM IS MADE TO THE EXCLUSIVE RIGHT TO USE "MESSAGE PHONE", APART FROM THE MARK AS SHOWN.
THE MARK CONSISTS OF THE WORDS "MESSAGE" AND "PHONE" FLANKING AN ENVELOPE DESIGN.
FOR CELLULAR TELEPHONES (U.S. CLS. 21, 23, 26, 36 AND 38).
BARNEY CHARLON, EXAMINING ATTORNEY

CLASS 9—(Continued).

SN 76-704,902. HARVEY, STEVE, ATLANTA, GA. AND MCDONALD, RUSHION, HOUSTON, TX. AND ANDERSON, RICKY, HOUSTON, TX. FILED 10-15-2010.



OWNER OF U.S. REG. NO. 3,875,238.
THE COLOR(S) BLACK AND RED IS/ARE CLAIMED AS A FEATURE OF THE MARK.

THE MARK CONSISTS OF THE WORD "LOCATE" IN BLACK. THE "O" IN IS THE FORM OF A BLACK MAGNIFYING GLASS, AND THE WORD "YOUR" APPEARS IN RED INSIDE THE "O". THIS ALL APPEARS ABOVE THE WORD "LOVE" WITH A RED HEART FORMING THE "V" AND THE REST OF THE LETTERS IN BLACK. THE PRESENCE OF WHITE IS INTENDED TO INDICATE TRANSPARENCY AND IS NOT A FEATURE OF THE MARK.

FOR MOTION PICTURE FILMS ABOUT DATING AND SOCIAL INTRODUCTION SERVICES IN WHICH SINGLE MEMBERS INTERESTED IN SERIOUS RELATIONSHIPS, CASUAL DATING OR FRIENDSHIPS WITH OTHER SINGLE MEMBERS SELECT FROM PROFILES TO LOCATE AN IDEAL MATE BY THEIR OWN SEARCH OR WITH THE ASSISTANCE OF THE ONLINE SEARCH ENGINE TO FIND THEIR TOP MATCHES (U.S. CLS. 21, 23, 26, 36 AND 38).

KATHERINE CHANG, EXAMINING ATTORNEY

SN 76-705,565. EMPYREAL SCIENCES, LLC, TEMPE, AZ. FILED 12-6-2010.

EMPYREAL SCIENCES

THE MARK CONSISTS OF STANDARD CHARACTERS WITHOUT CLAIM TO ANY PARTICULAR FONT, STYLE, SIZE, OR COLOR.

FOR COMPUTER SOFTWARE AND HARDWARE FOR MILITARY AND LAW ENFORCEMENT APPLICATIONS, NAMELY, INTELLIGENCE, OPTO-ELECTRONIC AND BALLISTICS SOFTWARE TO INCREASE THE ACCURACY OF SNIPER FIRE (U.S. CLS. 21, 23, 26, 36 AND 38).

FIRST USE 5-6-2005; IN COMMERCE 5-6-2005.
MORGAN WYNNE, EXAMINING ATTORNEY

CLASS 9—(Continued).

SN 76-705,579. HUMBERT, SHARON, SAN JUAN, PUERTO RICO, FILED 12-6-2010.



THE MARK CONSISTS OF A DESIGN OF TWO WINGS WITH A CIRCLE CONTAINING THE LETTERS "GA" IN THE CENTER OF THE WINGS AND THE WORDING "GUARDIAN ANGEL" APPEARING BELOW THE DESIGN. FOR PERSONAL SECURITY ALARMS (U.S. CLS. 21, 23, 26, 36 AND 38).

JENNY PARK, EXAMINING ATTORNEY

SN 76-707,144. BOXWAVE CORPORATION, BELLEVUE, WA. FILED 4-7-2011.

ELECTRASPAN

THE MARK CONSISTS OF STANDARD CHARACTERS WITHOUT CLAIM TO ANY PARTICULAR FONT, STYLE, SIZE, OR COLOR.

FOR BATTERIES AND BATTERY COVERS FOR ELECTRONIC DEVICES (U.S. CLS. 21, 23, 26, 36 AND 38). FIRST USE 6-7-2006; IN COMMERCE 6-7-2006.
JOHN E. MICHOS, EXAMINING ATTORNEY

SN 76-707,221. SHARP KABUSHIKI KAISHA, TA SHARP CORPORATION, OSAKA 545-8522, JAPAN, FILED 4-11-2011.

**AQUOS
PHONE**

OWNER OF U.S. REG. NO. 2,830,322.
NO CLAIM IS MADE TO THE EXCLUSIVE RIGHT TO USE "PHONE", APART FROM THE MARK AS SHOWN.

THE MARK IS PRESENTED IN A STYLIZED FORM OF THE WORDING "AQUOS PHONE", WITH THE WORD "AQUOS" POSITIONED AT THE TOP IN ALL CAPS AND THE WORD "PHONE" CENTERED VERTICALLY BENEATH THE WORD "AQUOS" ALSO IN ALL CAPS, BUT WITH A SMALLER FONT.

FOR MOBILE PHONES, SMART PHONES AND TELEPHONES (U.S. CLS. 21, 23, 26, 36 AND 38).
MARK SPARACINO, EXAMINING ATTORNEY

CLASS 9—(Continued).

SN 76-707,222. SHARP KABUSHIKI KAISHA, TA SHARP CORPORATION, OSAKA 545-8522, JAPAN, FILED 4-11-2011.

AQUOS PHONE

THE MARK CONSISTS OF STANDARD CHARACTERS WITHOUT CLAIM TO ANY PARTICULAR FONT, STYLE, SIZE, OR COLOR.

OWNER OF U.S. REG. NO. 2,830,322.
NO CLAIM IS MADE TO THE EXCLUSIVE RIGHT TO USE "PHONE", APART FROM THE MARK AS SHOWN.
FOR MOBILE PHONES, SMART PHONES AND TELEPHONES (U.S. CLS. 21, 23, 26, 36 AND 38).
MARK SPARACINO, EXAMINING ATTORNEY

SN 77-028,286. LG ELECTRONICS INC., SEOUL, REPUBLIC OF KOREA, FILED 10-24-2006.

BLACK JEWEL

THE MARK CONSISTS OF STANDARD CHARACTERS WITHOUT CLAIM TO ANY PARTICULAR FONT, STYLE, SIZE, OR COLOR.

OWNER OF UNITED KINGDOM REG. NO. 2436384, DATED 3-6-2009, EXPIRES 10-23-2016.
NO CLAIM IS MADE TO THE EXCLUSIVE RIGHT TO USE "BLACK", APART FROM THE MARK AS SHOWN.
FOR COMPUTER MONITORS; NOTEBOOK COMPUTERS; COMPUTERS; COMPUTER PRINTERS; COMPUTER NETWORK ADAPTERS (U.S. CLS. 21, 23, 26, 36 AND 38).
KATHLEEN M. VANSTON, EXAMINING ATTORNEY

CLASS 9—(Continued).

SN 77-314,092. PSION TEKLOGIX INC., MISSISSAUGA, CANADA, FILED 10-26-2007.



PRIORITY CLAIMED UNDER SEC. 44(D) ON CANADA APPLICATION NO. 1368288, FILED 10-19-2007, REG. NO. TMA770729, DATED 4-28-2011, EXPIRES 4-28-2026.

THE MARK CONSISTS OF THE WORD "IKON" IN LOWER CASE WITH TWO SMALL TRIANGLES ON TOP OF THE LETTER "O" ON A BLACK RECTANGLE.

FOR RUGGED HAND-HELD COMPUTERS, PERSONAL DIGITAL ASSISTANTS (PDAS), AND DATA PROCESSORS FOR PORTABLE RADIO FREQUENCY RECEIVING AND TRANSMITTING, LASER SCANNING, LINEAR AND AREA IMAGING, RFID READING, SECURE IDENTIFICATION AND CONTROL FOR TRANSMITTING, RECEIVING, VIEWING, UPDATING, PROCESSING AND MANAGING DATA, ASSET MANAGEMENT AND TRACKING, MOBILE CUSTOMER RELATIONSHIP MANAGEMENT, MOBILE TICKETING, PAYMENT PROCESSING, PERSONAL IDENTIFICATION COLLECTION AND VERIFICATION, DISPATCHING AND SCHEDULING, GENERAL DATA COLLECTION, EQUIPMENT MAINTENANCE, BREAK-FIX AND REPAIR, GPS-DRIVEN MAPPING AND DIRECTION FINDING (U.S. CLS. 21, 23, 26, 36 AND 38).
LESLIE RICHARDS, EXAMINING ATTORNEY

SN 77-505,370. ABC CORK CORPORATION, LONDON, ONTARIO, CANADA, FILED 6-23-2008.

ABC CORK

THE MARK CONSISTS OF STANDARD CHARACTERS WITHOUT CLAIM TO ANY PARTICULAR FONT, STYLE, SIZE, OR COLOR.

NO CLAIM IS MADE TO THE EXCLUSIVE RIGHT TO USE "CORK", APART FROM THE MARK AS SHOWN.
FOR MOUSE PADS (U.S. CLS. 21, 23, 26, 36 AND 38).
FIRST USE 7-1-2007; IN COMMERCE 3-24-2008.
ROBIN MITTLER, EXAMINING ATTORNEY

SN 77-639,894. FIRICH ENTERPRISES COMPANY LIMITED, SHUIR CITY, TAIWAN, FILED 12-24-2008.

VIVIPOS

THE MARK CONSISTS OF THE WORDING "VIVIPOS" WITH CIRCLES PLACED ABOVE THE LETTER "I".

FOR CASH REGISTERS, ELECTRONIC CASH REGISTERS, HANDHELD LASER BAR CODE SCANNER, MAGNETIC CODE CARD READERS, BAR CODE SCANNERS AND CHARGE CARD REGISTERS (U.S. CLS. 21, 23, 26, 36 AND 38).
FIRST USE 12-24-2008; IN COMMERCE 12-24-2008.
LESLIE RICHARDS, EXAMINING ATTORNEY

CLASS 9—(Continued).

SN 77-750,034. MOUNTZ, INC., SAN JOSE, CA. FILED 6-2-2009.

TORQUEMATE

THE MARK CONSISTS OF STANDARD CHARACTERS WITHOUT CLAIM TO ANY PARTICULAR FONT, STYLE, SIZE, OR COLOR.

FOR PORTABLE DIGITAL TORQUE TESTERS, ANALYZERS, AND DATA COLLECTORS (U.S. CLS. 21, 23, 26, 36 AND 38).

FIRST USE 11-17-1997; IN COMMERCE 11-17-1997.
DOMINIC J. FERRAIUOLO, EXAMINING ATTORNEY

SN 77-805,171. MONSTER CABLE PRODUCTS, INC., BRISBANE, CA. FILED 8-14-2009.

MUSIC MATTERS

THE MARK CONSISTS OF STANDARD CHARACTERS WITHOUT CLAIM TO ANY PARTICULAR FONT, STYLE, SIZE, OR COLOR.

NO CLAIM IS MADE TO THE EXCLUSIVE RIGHT TO USE "MUSIC", APART FROM THE MARK AS SHOWN.

FOR HEADPHONES; AUDIO AND VIDEO RECORDINGS, NAMELY, PRERECORDED COMPACT DISCS AND DVDS FEATURING MUSIC (U.S. CLS. 21, 23, 26, 36 AND 38).

DEZMONA MIZELLE, EXAMINING ATTORNEY

SN 77-828,804. MAZSPORT GARMENT MANUFACTURING INC., ST-LEONARD, QUEBEC, CANADA, FILED 9-17-2009.

SPRAYGUARD

THE MARK CONSISTS OF STANDARD CHARACTERS WITHOUT CLAIM TO ANY PARTICULAR FONT, STYLE, SIZE, OR COLOR.

PRIORITY CLAIMED UNDER SEC. 44(D) ON CANADA APPLICATION NO. 1450261, FILED 9-2-2009, REG. NO. 775069, DATED 8-20-2010, EXPIRES 8-20-2025.

FOR PROTECTIVE EQUIPMENT PROTECTIVE AGAINST FIRE, HEAT, WATER, PERFORATION, CHEMICALS, TOXIC GAS, GERMS, BACTERIA, BLOOD, BODY FLUIDS, PAINT OR INSECTS, NAMELY, COATS, HATS, CAPS, HELMETS, JACKETS, VESTS, PANTS, OVERALLS, SHIRTS, SOCKS, STOCKINGS, UNDERGARMENTS, NAMELY, UNDER-TOPS AND UNDER BOTTOMS, JUMP SUITS, WET-SUITS, BODY SUITS, GLOVES, GAUNTLETS, GOGGLES, GLASSES, MASKS, BELTS, SUSPENDERS, SHOES, BOOTS, AND FOOTCOVERS AND FACIAL NETS (U.S. CLS. 21, 23, 26, 36 AND 38).

KATHLEEN M. VANSTON, EXAMINING ATTORNEY

CLASS 9—(Continued).

SN 77-855,906. NEWAGE INDUSTRIES, INC., SOUTHAMPTON, PA. FILED 10-23-2009.

DOCULINK

THE MARK CONSISTS OF STANDARD CHARACTERS WITHOUT CLAIM TO ANY PARTICULAR FONT, STYLE, SIZE, OR COLOR.

FOR LABELS CARRYING MAGNETICALLY, OPTICALLY, OR ELECTRONICALLY RECORDED OR ENCODED INFORMATION MOLDED INTO TUBING, HOSES, FITTINGS AND RELATED ASSEMBLIES FOR USE IN ACCESSING ONLINE INFORMATION RELATING TO THEIR MANUFACTURE VIA A COMPUTER (U.S. CLS. 21, 23, 26, 36 AND 38).

KIMBERLY PERRY, EXAMINING ATTORNEY

SN 77-859,820. MONSTER CABLE PRODUCTS, INC., BRISBANE, CA. FILED 10-28-2009.

MUSIC REALLY MATTERS

THE MARK CONSISTS OF STANDARD CHARACTERS WITHOUT CLAIM TO ANY PARTICULAR FONT, STYLE, SIZE, OR COLOR.

NO CLAIM IS MADE TO THE EXCLUSIVE RIGHT TO USE "MUSIC", APART FROM THE MARK AS SHOWN.

FOR HEADPHONES, AUDIO AND VIDEO DEVICES, NAMELY, CABLES, WIRES, CONNECTORS, SPEAKERS, FM TRANSMITTERS; AND PRE-RECORDED COMPACT DISCS AND DVDS FEATURING MUSIC (U.S. CLS. 21, 23, 26, 36 AND 38).

DEZMONA MIZELLE, EXAMINING ATTORNEY

SN 77-872,663. SHUFFLE MASTER AUSTRALASIA PTY LIMITED, MILPERRA NSW, AUSTRALIA, FILED 11-13-2009.

SAVANNAH SUNSET

THE MARK CONSISTS OF STANDARD CHARACTERS WITHOUT CLAIM TO ANY PARTICULAR FONT, STYLE, SIZE, OR COLOR.

FOR ELECTRONIC GAMING MACHINES WITH OR WITHOUT VIDEO INPUT (U.S. CLS. 21, 23, 26, 36 AND 38).

EMILY CHUO, EXAMINING ATTORNEY

CLASS 9—(Continued).

SN 77-887,985. SECURE CARE PRODUCTS, INC., CONCORD, NH. FILED 12-7-2009.

DOOR GUARDIAN

THE MARK CONSISTS OF STANDARD CHARACTERS WITHOUT CLAIM TO ANY PARTICULAR FONT, STYLE, SIZE, OR COLOR.

FOR ELECTRONIC APPARATUS TO MONITOR THE MOVEMENT OF PEOPLE COMPRISING A TRANSMITTER, ANTENNA, ELECTRONIC DETECTION STATION, ELECTRONIC CONTROL STATION, POWER SUPPLY, ALARM AND SOFTWARE FOR USE IN MONITORING THE MOVEMENT OF PEOPLE, ALL SOLD INDIVIDUALLY OR AS A UNIT, EXCLUDING ACOUSTIC SOUND ALARMS; ALARM INSTALLATIONS AND ALARMS FOR EMERGENCY SHOWER AND EYE WASH UNITS; ALARM HORNS, NAMELY, ACOUSTIC SOUND ALARMS; ALARM INSTALLATIONS AND ALARMS FOR EMERGENCY EQUIPMENT; LABORATORY EMERGENCY EQUIPMENT, NAMELY, EMERGENCY EYE WASH BOWLS, EMERGENCY EYE AND FACE WASH BOWLS, EYE WASH UNITS, EYE/FACE SPRAY HEADS, DECK TOP EYE AND FACE WASH LABORATORY UNITS, PULL DOWN EMERGENCY EYE/FACE WASH SPRAY HEADS, HAND-HELD RECOILING HOSE LABORATORY EYE/FACE SPRAYING UNITS, EMERGENCY DRENCH SHOWERS, EMERGENCY DRENCH SHOWER AND EYE/FACE COMBINATION UNITS, AND SAFETY MARKERS, NAMELY, SELF ADHESIVE LUMINOUS MARKERS FOR APPLICATION TO SURFACE OF GOODS (U.S. CLS. 21, 23, 26, 36 AND 38).

NAAKWAMA ANKRAH, EXAMINING ATTORNEY

SN 77-933,057. VITESSE SEMICONDUCTOR CORPORATION, CAMARILLO, CA. FILED 2-10-2010.

CI-BCH

THE MARK CONSISTS OF STANDARD CHARACTERS WITHOUT CLAIM TO ANY PARTICULAR FONT, STYLE, SIZE, OR COLOR.

FOR INTEGRATED CIRCUITS INCORPORATING ALGORITHMS FOR USE IN PROCESSING HIGH SPEED OPTICAL TRANSMISSION SIGNALS (U.S. CLS. 21, 23, 26, 36 AND 38).

SARA BENJAMIN, EXAMINING ATTORNEY

CLASS 9—(Continued).

SN 77-933,059. VITESSE SEMICONDUCTOR CORPORATION, CAMARILLO, CA. FILED 2-10-2010.

CI-BCH-3

THE MARK CONSISTS OF STANDARD CHARACTERS WITHOUT CLAIM TO ANY PARTICULAR FONT, STYLE, SIZE, OR COLOR.

FOR INTEGRATED CIRCUITS INCORPORATING ALGORITHMS FOR USE IN PROCESSING HIGH SPEED OPTICAL TRANSMISSION SIGNALS (U.S. CLS. 21, 23, 26, 36 AND 38).

SARA BENJAMIN, EXAMINING ATTORNEY

SN 77-933,061. VITESSE SEMICONDUCTOR CORPORATION, CAMARILLO, CA. FILED 2-10-2010.

CI-BCH-4

THE MARK CONSISTS OF STANDARD CHARACTERS WITHOUT CLAIM TO ANY PARTICULAR FONT, STYLE, SIZE, OR COLOR.

FOR INTEGRATED CIRCUITS INCORPORATING ALGORITHMS FOR USE IN PROCESSING HIGH SPEED OPTICAL TRANSMISSION SIGNALS (U.S. CLS. 21, 23, 26, 36 AND 38).

SARA BENJAMIN, EXAMINING ATTORNEY

SN 77-936,793. INVAR CONSULTING, LTD., LUGANO, SWITZERLAND, FILED 2-16-2010.

GENOMETRICA

THE MARK CONSISTS OF STANDARD CHARACTERS WITHOUT CLAIM TO ANY PARTICULAR FONT, STYLE, SIZE, OR COLOR.

FOR SCIENTIFIC APPARATUS AND INSTRUMENTS, NAMELY, DNA SEQUENCERS, DNA/RNA SYNTHESIZERS, ELECTROPHORESIS SYSTEMS, CAPILLARY ELECTROPHORESIS INSTRUMENTATION, POLYMERASE CHAIN REACTION (PCR) INSTRUMENTATION, REAL-TIME PCR INSTRUMENTATION, END POINT PCR INSTRUMENTATION, DIGITAL PCR INSTRUMENTATION, THERMOCYCLERS, HYBRIDIZATION INSTRUMENTATION, GENOME ANALYZERS, INSTRUMENTS FOR GENE EXPRESSION ANALYSIS, FLUORESCENT IMAGE ANALYZERS, FLUORESCENT CYTOMETRY INSTRUMENTATION, FLUORESCENT SPECTROMETRY INSTRUMENTATION, SPECTROMETERS, SPECTROPHOTOMETERS, SPECTRA-FLOW-FLUOROMETERS, PHOTODETECTORS, BEAD READERS, LASERS, SAMPLE ANALYZERS, POWER SUPPLY DEVICES, AND COMPONENTS THEREOF FOR MEDICAL AND MOLECULAR DIAGNOSTICS (U.S. CLS. 21, 23, 26, 36 AND 38).

GIANCARLO CASTRO, EXAMINING ATTORNEY

CLASS 9—(Continued).

SN 77-938,576. EMOND, STEPHEN, BELOEIL, CANADA, FILED 2-18-2010.

SONOPATHY

THE MARK CONSISTS OF STANDARD CHARACTERS WITHOUT CLAIM TO ANY PARTICULAR FONT, STYLE, SIZE, OR COLOR.

THE WORDING "SONOPATHY" HAS NO MEANING IN A FOREIGN LANGUAGE.

FOR DOWNLOADABLE ELECTRONIC DATA FILES FEATURING RECORDED ENERGY SIGNATURE FREQUENCIES FOR USE IN RELIEVING STRESS (U.S. CLS. 21, 23, 26, 36 AND 38).

FIRST USE 2-16-2007; IN COMMERCE 2-16-2007.
TRACY FLETCHER, EXAMINING ATTORNEY

SN 77-945,648. RENKARA MEDIA GROUP, INVERNESS, IL, FILED 2-26-2010.

iPhraseBook

THE MARK CONSISTS OF STANDARD CHARACTERS WITHOUT CLAIM TO ANY PARTICULAR FONT, STYLE, SIZE, OR COLOR.

FOR SOFTWARE APPLICATIONS PROVIDING PHRASES IN MANY LANGUAGES UTILIZING MOBILE COMMUNICATION DEVICES; THE AFOREMENTIONED SOFTWARE APPLICATIONS BEING SELF CONTAINED AND NOT INTERNET CONNECTED OR ENABLED; THE AFOREMENTIONED SOFTWARE DOWNLOADABLE FROM THE INTERNET (U.S. CLS. 21, 23, 26, 36 AND 38).

ELI HELLMAN, EXAMINING ATTORNEY

SN 77-953,229. MEGASYS HOSPITALITY SYSTEMS, INC., TULSA, OK, FILED 3-8-2010.

MEGATOUCH

THE MARK CONSISTS OF STANDARD CHARACTERS WITHOUT CLAIM TO ANY PARTICULAR FONT, STYLE, SIZE, OR COLOR.

FOR COMPUTER SOFTWARE FOR MANAGING PROPERTIES AND FUNCTIONS IN THE CAMP HOSPITALITY INDUSTRY, NAMELY, PROPERTY MANAGEMENT, CONDOMINIUM AND TIME SHARE MANAGEMENT, HOTEL RESERVATIONS, CHECK IN AND FRONT OFFICE MANAGEMENT, POINT OF SALE ENTRY AND RECORD KEEPING, BACK OFFICE ACCOUNTING AND MANAGEMENT; AND PRINTED INSTRUCTIONAL MANUALS THEREFOR SOLD AS A UNIT (U.S. CLS. 21, 23, 26, 36 AND 38).

FIRST USE 6-30-1999; IN COMMERCE 6-30-1999.
JEFFERY COWARD, EXAMINING ATTORNEY

CLASS 9—(Continued).

SN 79-076,090. INTRINSIC ID B.V., NETHERLANDS, FILED 10-26-2009.

QUIDDICARD

THE MARK CONSISTS OF STANDARD CHARACTERS WITHOUT CLAIM TO ANY PARTICULAR FONT, STYLE, SIZE, OR COLOR.

PRIORITY DATE OF 4-27-2009 IS CLAIMED.

OWNER OF INTERNATIONAL REGISTRATION 1021524 DATED 10-26-2009, EXPIRES 10-26-2019.

FOR COMPUTER HARDWARE AND SOFTWARE FOR STORAGE OF KEYS TO SECURE SEMICONDUCTOR PRODUCTS AGAINST CLONING, TAMPERING, THEFT OF SERVICE AND REVERSE ENGINEERING; ELECTRONIC LOCKS, ELECTRONIC KEY CARDS AND ELECTRONIC KEY CARD READERS, ENCODING APPARATUS FOR ELECTRONIC KEY CARDS, MAGNETIC ENCODED KEY CARDS (U.S. CLS. 21, 23, 26, 36 AND 38).

ANN E. SAPPENFIELD, EXAMINING ATTORNEY

SN 79-084,422. AB ELECTROLUX, STOCKHOLM, SWEDEN, FILED 5-27-2010.

COMPASS PRO

THE MARK CONSISTS OF STANDARD CHARACTERS WITHOUT CLAIM TO ANY PARTICULAR FONT, STYLE, SIZE, OR COLOR.

OWNER OF INTERNATIONAL REGISTRATION 1043570 DATED 5-27-2010, EXPIRES 5-27-2020.

NO CLAIM IS MADE TO THE EXCLUSIVE RIGHT TO USE "PRO", APART FROM THE MARK AS SHOWN.

FOR MICROPROCESSORS; WASHING MACHINE COMPUTER SOFTWARE FOR MANAGING ALL PROCESSES AND PARAMETERS OF THE WASH AND DRY CYCLE FOR USE BY PROFESSIONAL APPLIANCE TECHNICIANS AND FOR USE IN PROFESSIONAL DEVELOPMENT AND EDUCATION (U.S. CLS. 21, 23, 26, 36 AND 38).

KATHERINE CHANG, EXAMINING ATTORNEY

CLASS 9—(Continued).

SN 79-086,633. A & D COMPANY, LIMITED, TOKYO, JAPAN, FILED 8-6-2010.

AD-XPRTS

THE MARK CONSISTS OF STANDARD CHARACTERS WITHOUT CLAIM TO ANY PARTICULAR FONT, STYLE, SIZE, OR COLOR.

OWNER OF INTERNATIONAL REGISTRATION 1049150 DATED 8-6-2010, EXPIRES 8-6-2020.

FOR COMPUTERS; COMPUTER PROGRAMS FOR AUTOMOTIVE DEVELOPMENT, MEDICAL ANALYSIS, BLOOD PRESSURE ANALYSIS, WEIGHING, MOISTURE ANALYSIS, VIBRATION AND NOISE ANALYSIS AND MATERIAL TESTING DATA ANALYSIS; ELECTRONIC MACHINES, NAMELY, ULTRASONIC FLAW DETECTORS, DIGITAL-TO-ANALOG CONVERTERS, ECHO SOUNDERS, ULTRASONIC SENSORS, INTEGRATED CIRCUITS, ELECTRONIC SIMULATORS IN THE NATURE OF COMPUTER HARDWARE AND SOFTWARE FOR SIMULATING THE PHYSICAL PROPERTIES AND CHARACTERISTICS OF INDUSTRIAL MATERIALS, AND THEIR STRUCTURAL PARTS; MEASURING OR TESTING MACHINES, NAMELY, BALANCES, SCALES, TEMPERATURE INDICATORS, MOISTURE MEASURING METERS, VISCOSIMETERS, COUNTING SCALES, LOAD CELLS, HYGROMETERS, GRAVIMETERS, FFT ANALYZERS, PROGRAM CONTROL MACHINES AND INSTRUMENTS IN THE NATURE OF COMPUTER HARDWARE AND ITS OPERATING SOFTWARE FOR RESEARCH, DEVELOPMENT AND TESTING (U.S. CLS. 21, 23, 26, 36 AND 38).

REBECCA POVARCHUK, EXAMINING ATTORNEY

CLASS 9—(Continued).

SN 79-088,485. DAIHEN CORPORATION, OSAKA 532-8512, JAPAN, FILED 8-27-2010.

V i P h i

PRIORITY DATE OF 7-20-2010 IS CLAIMED.

OWNER OF INTERNATIONAL REGISTRATION 1054351 DATED 8-27-2010, EXPIRES 8-27-2020.

FOR HIGH-FREQUENCY MEASURING APPARATUS; HIGH FREQUENCY MEASURING APPARATUS FOR MEASURING CURRENT, VOLTAGE, POWER AND PHASE OF HIGH-FREQUENCY SIGNALS, NAMELY, ELECTRIC AND MAGNETIC METERS AND TESTERS, NAMELY, AMMETERS, VOLTMETERS, WATTMETERS AND PHASE INDICATORS; HIGH-FREQUENCY ELECTRICAL POWER SUPPLIES; FREQUENCY REGULATORS; ROTARY CONVERTERS; POWER REGULATORS (U.S. CLS. 21, 23, 26, 36 AND 38).

MORGAN WYNNE, EXAMINING ATTORNEY

SN 79-087,898. DAIHEN CORPORATION, OSAKA 532-8512, JAPAN, FILED 8-27-2010.



PRIORITY DATE OF 7-20-2010 IS CLAIMED.

OWNER OF INTERNATIONAL REGISTRATION 1052617 DATED 8-27-2010, EXPIRES 8-27-2020.

THE COLOR(S) BLUE, DARK BLUE, BLACK, RED, PURPLE AND GREEN IS/ARE CLAIMED AS A FEATURE OF THE MARK.

THE RECTANGULAR FRAME IS BLUE; THE LETTERS "V" AND "I" IN THE RECTANGULAR FRAME ARE BLACK; THE TRIANGLE ELEMENT ON THE RIGHT SIDE OF THE LETTER "I" IS RED; THE RING ON THE RIGHT SIDE OF THE TRIANGLE ELEMENT IS DARK BLUE; THE NEEDLE-SHAPED BAR PASSING THROUGH THE RING IS PURPLE; THE CIRCLE BELOW THE RECTANGULAR FRAME IS GREEN.

FOR HIGH-FREQUENCY MEASURING APPARATUS; HIGH FREQUENCY MEASURING APPARATUS FOR MEASURING CURRENT, VOLTAGE, POWER AND PHASE OF HIGH-FREQUENCY SIGNALS, NAMELY, ELECTRIC AND MAGNETIC METERS AND TESTERS, NAMELY, AMMETERS, VOLTMETERS, WATTMETERS AND PHASE INDICATORS; HIGH-FREQUENCY ELECTRICAL POWER SUPPLIES; FREQUENCY REGULATORS; ROTARY CONVERTERS; POWER REGULATORS (U.S. CLS. 21, 23, 26, 36 AND 38).

MORGAN WYNNE, EXAMINING ATTORNEY

SN 79-089,098. TYCO ELECTRONICS AMP GMBH, FED REP GERMANY, FILED 6-7-2010.

MCON

THE MARK CONSISTS OF STANDARD CHARACTERS WITHOUT CLAIM TO ANY PARTICULAR FONT, STYLE, SIZE, OR COLOR.

PRIORITY DATE OF 4-6-2010 IS CLAIMED.

OWNER OF INTERNATIONAL REGISTRATION 1056050 DATED 6-7-2010, EXPIRES 6-7-2020.

FOR ELECTRIC AND ELECTRICAL CONTACTS; CONNECTORS, NAMELY, ELECTRICAL CONNECTORS, POWER CONNECTORS, PLUG CONNECTORS, RECEPTACLE CONTACTS, BLADE CONTACTS, SINGLE AND WIRE SEAL PLUGS; ELECTRIC AND ELECTRICAL CONNECTOR SYSTEMS COMPRISING ELECTRICAL CONNECTORS, POWER CONNECTORS, JUNCTION BOXES, ELECTRICAL SOCKETS, CABLE ASSEMBLY SYSTEMS, RECEPTACLE CONTACTS, BLADE CONTACTS, SINGLE AND WIRE SEAL PLUGS (U.S. CLS. 21, 23, 26, 36 AND 38).

RON FAIRBANKS, EXAMINING ATTORNEY

CLASS 9—(Continued).

SN 79-089,868. ZXY SPORT TRACKING AS, NORWAY,
FILED 9-6-2010.



PRIORITY DATE OF 7-5-2010 IS CLAIMED.
OWNER OF INTERNATIONAL REGISTRATION 1058016
DATED 9-6-2010, EXPIRES 9-6-2020.

NO CLAIM IS MADE TO THE EXCLUSIVE RIGHT TO
USE "SPORT TRACKING" AND "POWERED", APART
FROM THE MARK AS SHOWN.

FOR INTERFACE CARDS FOR DATA PROCESSING
EQUIPMENT IN THE FORM OF PRINTED CIRCUITS;
COMPUTER SOFTWARE FOR SEARCH AND ANALYSIS
IN THE FIELD OF WIRELESS SENSOR TECHNOLOGIES
FOR SPORT (U.S. CLS. 21, 23, 26, 36 AND 38).

ANNE E. GUSTASON, EXAMINING ATTORNEY

SN 79-091,415. GREEN ENERGY OPTIONS LTD, UNITED
KINGDOM, FILED 11-18-2010.



PRIORITY DATE OF 5-20-2010 IS CLAIMED.
OWNER OF INTERNATIONAL REGISTRATION 1062123
DATED 11-18-2010, EXPIRES 11-18-2020.

NO CLAIM IS MADE TO THE EXCLUSIVE RIGHT TO
USE "GREEN ENERGY", APART FROM THE MARK AS
SHOWN.

THE MARK CONSISTS OF THE STYLIZED WORD
"GEO", A VERTICAL LINE, AND THE LANGUAGE
"GREEN ENERGY OPTIONS".

FOR DEVICES FOR DISPLAYING ELECTRICITY,
GAS, AND WATER CONSUMPTION, NAMELY, WATER,
GAS, AND ELECTRICITY METERS; ENERGY CON-
TROL DEVICES AND APPARATUS FOR USE IN EN-
ERGY MANAGEMENT (U.S. CLS. 21, 23, 26, 36 AND 38).

MICHELLE DUBOIS, EXAMINING ATTORNEY

CLASS 9—(Continued).

SN 79-092,731. KABUSHIKI KAISHA AUDIO-TECHNICA,
JAPAN, FILED 12-10-2010.



PRIORITY DATE OF 12-6-2010 IS CLAIMED.
OWNER OF INTERNATIONAL REGISTRATION 1065608
DATED 12-10-2010, EXPIRES 12-10-2020.

NO CLAIM IS MADE TO THE EXCLUSIVE RIGHT TO
USE "50TH ANNIVERSARY", APART FROM THE MARK
AS SHOWN.

THE MARK CONSISTS OF A SOLID CIRCLE, IN THE
MIDDLE OF THE CIRCLE IS A STYLIZED TRIANGLE
WITH A SMALLER TRIANGLE INSIDE THE LOWER
RIGHT PORTION OF THE TRIANGLE, SURROUNDING
THE TRIANGLE ARE FIVE CONCENTRIC CIRCLES, SUR-
ROUNDING THE CIRCLES IS THE WORDING "ANNIVER-
SARY" AT THE TOP, AND "50TH" AT THE BOTTOM OF
THE CIRCLE.

FOR HEADPHONES; SPEAKERS; MICROPHONE;
HEADPHONE AMPLIFIERS; ELECTRICAL PHONO-
GRAPH RECORD TURNTABLE CARTRIDGES (U.S.
CLS. 21, 23, 26, 36 AND 38).

SCOTT BIBB, EXAMINING ATTORNEY

SN 79-093,894. AEROGILITY LIMITED, OXFORD, OXFORD-
SHIRE, UNITED KINGDOM, FILED 1-24-2011.

Aerogility

THE MARK CONSISTS OF STANDARD CHARACTERS
WITHOUT CLAIM TO ANY PARTICULAR FONT, STYLE,
SIZE, OR COLOR.

OWNER OF INTERNATIONAL REGISTRATION 1068021
DATED 1-24-2011, EXPIRES 1-24-2021.

FOR COMPUTER SOFTWARE FOR USE IN DATA-
BASE MANAGEMENT (U.S. CLS. 21, 23, 26, 36 AND 38).

TEJBIR SINGH, EXAMINING ATTORNEY

CLASS 9—(Continued).

SN 79-093,895. AEROGILITY LIMITED, OXFORDSHIRE, UNITED KINGDOM, FILED 1-24-2011.



OWNER OF INTERNATIONAL REGISTRATION 1068022 DATED 1-24-2011, EXPIRES 1-24-2021.

THE MARK CONSISTS OF THE STYLIZED TERM "AEROGILITY" WITH TWO CHEVRONS AT THE END. THE UPPER PART OF THE TWO CHEVRONS IS LIGHTER THAN THE REST OF THE MARK.

FOR COMPUTER SOFTWARE FOR USE IN DATABASE MANAGEMENT (U.S. CLS. 21, 23, 26, 36 AND 38).
TEJBIR SINGH, EXAMINING ATTORNEY

CLASS 9—(Continued).

SN 79-097,303. ALPINA SPORTS GMBH, FED REP GERMANY, FILED 4-13-2011.



THE MARK CONSISTS OF STANDARD CHARACTERS WITHOUT CLAIM TO ANY PARTICULAR FONT, STYLE, SIZE, OR COLOR.

OWNER OF INTERNATIONAL REGISTRATION 1076886 DATED 4-13-2011, EXPIRES 4-13-2021.

FOR SKI GOGGLES, SPORTS GOGGLES, SWIMMING GOGGLES, SUNGLASSES, CYCLING GOGGLES, PROTECTIVE GOGGLES FOR WORKERS, SPECTACLES, SPECTACLE FRAMES AND LENSES; SPECTACLE LENSES MADE OF PLASTIC; PROTECTIVE HELMETS FOR CYCLISTS, FOR SKIERS, FOR SKI JUMPERS, FOR ALPINISTS, FOR CANOEISTS, FOR EQUESTRIANS; SPORTS HELMETS (U.S. CLS. 21, 23, 26, 36 AND 38).
TOBY BULLOFF, EXAMINING ATTORNEY

SN 79-093,928. THE VISION LOUNGE PTY LTD, AUSTRALIA, FILED 1-19-2011.



THE MARK CONSISTS OF STANDARD CHARACTERS WITHOUT CLAIM TO ANY PARTICULAR FONT, STYLE, SIZE, OR COLOR.

OWNER OF INTERNATIONAL REGISTRATION 1068112 DATED 1-19-2011, EXPIRES 1-19-2021.

OWNER OF U.S. REG. NO. 2,501,280.
FOR SUNGLASSES NOT FOR SAFETY, PROTECTIVE, WELDING, MEDICAL, INDUSTRIAL OR SPORTING USE (U.S. CLS. 21, 23, 26, 36 AND 38).
ROBERT STRUCK, EXAMINING ATTORNEY

SN 79-097,805. XIAMEN 35.COM TECHNOLOGY CO., LTD, CHINA, FILED 4-11-2011.



OWNER OF INTERNATIONAL REGISTRATION 1078362 DATED 4-11-2011, EXPIRES 4-11-2021.

NO CLAIM IS MADE TO THE EXCLUSIVE RIGHT TO USE "PHONE", APART FROM THE MARK AS SHOWN.

FOR TELEPHONES; VIDEO TELEPHONES; PORTABLE TELEPHONES; FIBER OPTIC CABLES; SATELLITE NAVIGATIONAL APPARATUS; RADIOTELEPHONY SETS; NAVIGATION APPARATUS FOR VEHICLES; RADAR APPARATUS; WALKIE-TALKIES (U.S. CLS. 21, 23, 26, 36 AND 38).
REBECCA POVARCHUK, EXAMINING ATTORNEY

SN 79-096,843. GAOYAO HONGYI ELECTRONICS CO., LTD., CHINA, FILED 4-11-2011.



OWNER OF INTERNATIONAL REGISTRATION 1075599 DATED 4-11-2011, EXPIRES 4-11-2021.

FOR CAPACITORS (U.S. CLS. 21, 23, 26, 36 AND 38).
MATTHEW EINSTEIN, EXAMINING ATTORNEY

SN 79-098,015. XINGLE GROUP CO., LTD., CHINA, FILED 4-11-2011.



OWNER OF INTERNATIONAL REGISTRATION 1079096 DATED 4-11-2011, EXPIRES 4-11-2021.

THE MARK CONSISTS OF THE STYLIZED WORD "XINE".

THE WORDING "XINE" HAS NO MEANING IN A FOREIGN LANGUAGE.

FOR ELECTRIC WIRES AND CABLES; ELECTRICAL TRANSFORMERS; GALVANIC BATTERIES; FLAT IRONS, ELECTRIC; CONNECTIONS FOR ELECTRIC LINES; ELECTROMAGNETIC COILS (U.S. CLS. 21, 23, 26, 36 AND 38).
REBECCA POVARCHUK, EXAMINING ATTORNEY

CLASS 9—(Continued).

SN 79-098,147. HALFBRICK STUDIOS PTY LTD, AUSTRALIA, FILED 4-11-2011.

FRUIT NINJA

THE MARK CONSISTS OF STANDARD CHARACTERS WITHOUT CLAIM TO ANY PARTICULAR FONT, STYLE, SIZE, OR COLOR.

PRIORITY DATE OF 1-25-2011 IS CLAIMED.

OWNER OF INTERNATIONAL REGISTRATION 1079351 DATED 4-11-2011, EXPIRES 4-11-2021.

FOR COMPUTER GAME PROGRAMS; COMPUTER GAMES ADAPTED FOR USE WITH AN EXTERNAL DISPLAY SCREEN OR MONITOR; COMPUTER GAMES ENTERTAINMENT SOFTWARE; COMPUTER GAMES PROGRAMS; COMPUTER GAMES PROGRAMS DOWNLOADED VIA THE INTERNET; COMPUTER GAMES SOFTWARE; COMPUTER PROGRAMS FOR COMPUTER GAMES; ELECTRIC COMPUTER GAMES ADAPTED FOR USE WITH AN EXTERNAL DISPLAY SCREEN OR MONITOR; ELECTRIC COMPUTER GAMES ADAPTED FOR USE WITH VISUAL DISPLAY UNITS; HAND HELD COMPUTER GAMES FOR USE WITH TELEVISION RECEIVERS ONLY; PROGRAMS FOR USE WITH COMPUTER GAMES (U.S. CLS. 21, 23, 26, 36 AND 38).

REBECCA POVARCHUK, EXAMINING ATTORNEY

CLASS 9—(Continued).

SN 79-098,811. SGE ANALYTICAL SCIENCE PTY LTD, AUSTRALIA, FILED 3-30-2011.

EPREP

THE MARK CONSISTS OF STANDARD CHARACTERS WITHOUT CLAIM TO ANY PARTICULAR FONT, STYLE, SIZE, OR COLOR.

OWNER OF INTERNATIONAL REGISTRATION 1081121 DATED 3-30-2011, EXPIRES 10-26-2021.

FOR SCIENTIFIC AND MEASURING EQUIPMENT BEING PRECISION SYRINGES; MANUAL AND AUTOMATED PRECISION SYRINGES INCORPORATING A DIGITAL DRIVE MEASURING UNIT FOR LABORATORY USE; DIGITAL REGULATING APPARATUS FOR REGULATING THE FLOW OF GASES AND LIQUIDS; DIGITAL MEASURING INSTRUMENTS FOR MEASURING LIQUIDS; DIGITAL LIQUID ANALYSERS (U.S. CLS. 21, 23, 26, 36 AND 38).

PATRICIA EVANKO, EXAMINING ATTORNEY

SN 79-098,709. FILOPHONE ELECTRONICS AS, NORWAY, FILED 12-23-2010.

FILOPHONE

THE MARK CONSISTS OF STANDARD CHARACTERS WITHOUT CLAIM TO ANY PARTICULAR FONT, STYLE, SIZE, OR COLOR.

OWNER OF INTERNATIONAL REGISTRATION 1080879 DATED 12-23-2010, EXPIRES 8-10-2020.

FOR DATA PROCESSING EQUIPMENT AND COMPUTERS; APPARATUS FOR RECORDING, TRANSMISSION OR REPRODUCTION OF SOUND, TEXT OR IMAGES; TELEPHONE APPARATUS; TELEPHONE TRANSMITTERS; RADIOS; TELEVISION APPARATUS (U.S. CLS. 21, 23, 26, 36 AND 38).

ELIZABETH KAJUBI, EXAMINING ATTORNEY

SN 85-003,473. HARMAN INTERNATIONAL INDUSTRIES, INCORPORATED, NORTHRIDGE, CA. FILED 3-31-2010.

HALOSONIC

THE MARK CONSISTS OF STANDARD CHARACTERS WITHOUT CLAIM TO ANY PARTICULAR FONT, STYLE, SIZE, OR COLOR.

PRIORITY CLAIMED UNDER SEC. 44(D) ON ERPNCMNTY TM OFC APPLICATION NO. 008595993, FILED 10-6-2009, REG. NO. 008595993, DATED 5-27-2010, EXPIRES 6-10-2019.

FOR AMPLIFIERS FOR USE IN LAND BASED SELF PROPELLED VEHICLES OPERATING ON WHEELS; POWER AMPLIFIERS FOR USE IN LAND BASED SELF PROPELLED VEHICLES OPERATING ON WHEELS; SOFTWARE FOR NOISE CANCELLATION AND FOR ACTIVE NOISE CONTROL; AND SOFTWARE FOR NOISE CANCELLATION AND FOR ACTIVE NOISE CONTROL INCLUDING ENGINE ORDER CANCELLATION AND ENGINE NOISE CANCELLATION, ROAD NOISE CANCELLATION, AND ELECTRONIC SOUND SYNTHESIS FOR USE IN LAND BASED SELF PROPELLED VEHICLES OPERATING ON WHEELS; MICROPHONES; LOUDSPEAKERS FOR USE IN LAND BASED SELF PROPELLED VEHICLES OPERATING ON WHEELS; SOUND PROCESSORS; HEAD UNITS, NAMELY, VEHICLE INFOTAINMENT SYSTEMS, NAMELY, RADIOS AND AUDIO VIDEO DISPLAY UNITS; CONTROL MODULES WHICH PROCESS EXTERNAL DATA AND AUDIO SIGNALS FOR NOISE CANCELLATION AND FOR ACTIVE NOISE CONTROL FOR AUDIO AND VIDEO SYSTEMS; INPUT MODULES WHICH PROCESS EXTERNAL DATA AND AUDIO SIGNALS FOR NOISE CANCELLATION AND FOR ACTIVE NOISE CONTROL FOR AUDIO AND VIDEO SYSTEMS; MEMORY MODULES FOR STORING DATA AND PRE-SET USER OPTIONS (U.S. CLS. 21, 23, 26, 36 AND 38).

HENRY S. ZAK, EXAMINING ATTORNEY

SN 79-098,805. INTEGRATED DESIGN LIMITED, UNITED KINGDOM, FILED 3-7-2011.

GLASSWING

THE MARK CONSISTS OF STANDARD CHARACTERS WITHOUT CLAIM TO ANY PARTICULAR FONT, STYLE, SIZE, OR COLOR.

PRIORITY DATE OF 9-10-2010 IS CLAIMED.

OWNER OF INTERNATIONAL REGISTRATION 1081104 DATED 3-7-2011, EXPIRES 10-3-2021.

FOR ELECTRONIC AND OPTICAL ENTRANCE CONTROL DEVICES, NAMELY, INFRARED TRANSMITTERS AND RECEIVERS, ELECTRONIC CIRCUITRY AND COMPUTER HARDWARE AND SOFTWARE FOR USE IN CONNECTION THEREWITH; ELECTRONICALLY AND OPTICALLY CONTROLLED SECURITY GATES AND TURNSTILES (U.S. CLS. 21, 23, 26, 36 AND 38).

VERNA BETH RIRIE, EXAMINING ATTORNEY

CLASS 9—(Continued).

SN 85-012,978. SONY ELECTRONICS INC., SAN DIEGO, CA. FILED 4-13-2010.

View-DR

THE MARK CONSISTS OF STANDARD CHARACTERS WITHOUT CLAIM TO ANY PARTICULAR FONT, STYLE, SIZE, OR COLOR.

FOR ELECTRONIC SHUTTERS, IMAGERS AND SOFTWARE FOR OPERATION OF SUCH SHUTTERS AND IMAGERS, AVAILABLE AS INTEGRAL COMPONENTS OF SECURITY CAMERAS, FOR THE PURPOSE OF CAPTURING MULTIPLE HIGH SPEED IMAGES (U.S. CLS. 21, 23, 26, 36 AND 38).

HENRY S. ZAK, EXAMINING ATTORNEY



SN 85-012,998. MITSUBISHI ELECTRIC CORPORATION, CHIYODA-KU, TOKYO, JAPAN, FILED 4-13-2010.

SLMP

THE MARK CONSISTS OF STANDARD CHARACTERS WITHOUT CLAIM TO ANY PARTICULAR FONT, STYLE, SIZE, OR COLOR.

PRIORITY CLAIMED UNDER SEC. 44(D) ON JAPAN APPLICATION NO. 2010-019605, FILED 3-15-2010, REG. NO. 5358958, DATED 10-8-2010, EXPIRES 10-8-2020.

FOR DATA NETWORKING HARDWARE AND SOFTWARE FOR TRANSMITTING AND RECEIVING INFORMATION IN ACCORDANCE WITH COMMUNICATION PROTOCOLS THEREFOR IN A NETWORK FOR FACTORY AUTOMATION; COMPUTER PROGRAMS FOR CONNECTING DIFFERENT TYPE NETWORKS IN FACTORY AUTOMATION; COMPUTERS, WIRED, WIRELESS RADIO AND TELEPHONE DATA TRANSMITTERS, WIRED, WIRELESS RADIO AND TELEPHONE DATA RECEIVERS, ELECTRIC CABLES, INPUT AND OUTPUT MODULES FOR INTERFACING CONTROL AND DATA SIGNALS BETWEEN INDUSTRIAL AUTOMATION DEVICES, PROGRAMMABLE LOGIC CONTROLLERS, COMPUTER INTERFACE BOARDS OR CARDS FOR DATA PROCESSING EQUIPMENT, ELECTRIC INVERTERS, ELECTRONIC CONTROLS FOR MOTORS, COMPUTER DISPLAY MONITORS, WATT-HOUR METERS, ALL FOR USE IN FACTORY AUTOMATION (U.S. CLS. 21, 23, 26, 36 AND 38).

EDWARD NELSON, EXAMINING ATTORNEY

CLASS 9—(Continued).

SN 85-045,082. NEC DISPLAY SOLUTIONS, LTD., TOKYO, JAPAN, FILED 5-21-2010.

DISPLAYSYNC PRO

THE MARK CONSISTS OF STANDARD CHARACTERS WITHOUT CLAIM TO ANY PARTICULAR FONT, STYLE, SIZE, OR COLOR.

NO CLAIM IS MADE TO THE EXCLUSIVE RIGHT TO USE "PRO", APART FROM THE MARK AS SHOWN.

FOR A FEATURE OF COMPUTER MONITORS, FLAT PANEL COMPUTER DISPLAY SCREENS, LIQUID CRYSTAL DISPLAYS, PLASMA DISPLAYS PANELS, LIGHT EMITTING DIODE (LED) DISPLAYS AND LASER DISPLAY MONITORS, NAMELY, CONTROL BUTTONS ON COMPUTER MONITORS AND DISPLAYS TO CONTROL MULTIPLE COMPUTERS (U.S. CLS. 21, 23, 26, 36 AND 38).

FIRST USE 2-8-2010; IN COMMERCE 2-8-2010.
NAPOLEON SHARMA, EXAMINING ATTORNEY



SN 85-049,401. OLYMPUS CORPORATION, TOKYO, JAPAN, FILED 5-27-2010.

38DL PLUS

THE MARK CONSISTS OF STANDARD CHARACTERS WITHOUT CLAIM TO ANY PARTICULAR FONT, STYLE, SIZE, OR COLOR.

FOR NONDESTRUCTIVE TESTING INSTRUMENTS, NAMELY, ULTRASONIC THICKNESS GAUGES, NAMELY, PRECISION THICKNESS GAUGES AND CORROSION THICKNESS GAUGES; ULTRASOUND PRODUCTS AND INSTRUMENTS, NAMELY, ULTRASONIC INSPECTION DEVICES AND PROBES FOR NON-MEDICAL, NON-DESTRUCTIVE TESTING; AND ULTRASONIC TESTING PRODUCTS AND INSTRUMENTS, NAMELY, ULTRASONIC THICKNESS TESTERS AND HARDNESS TESTERS, FOR NON-MEDICAL USE (U.S. CLS. 21, 23, 26, 36 AND 38).

RON FAIRBANKS, EXAMINING ATTORNEY

CLASS 9—(Continued).

SN 85-050,361. DILL AIR CONTROL PRODUCTS, LLC, OXFORD, NC. FILED 5-28-2010.

1080K

THE MARK CONSISTS OF STANDARD CHARACTERS WITHOUT CLAIM TO ANY PARTICULAR FONT, STYLE, SIZE, OR COLOR.

SEC. 2(F).

FOR KITS COMPOSED OF REPLACEMENT PARTS TO SERVICE VEHICLES WITH TIRE-PRESSURE MOUNTING-SYSTEM (TPMS) SENSORS, NAMELY, SEALING VALVE CAPS, DYNAMIC ELECTROLESS NICKEL-PLATED VALVE CORES, ANODIZED ALUMINUM HEX CUTS, RIM SEAL GROMMETS AND WASHERS (U.S. CLS. 21, 23, 26, 36 AND 38).

FIRST USE 2-28-2006; IN COMMERCE 2-28-2006.

MARIA-VICTORIA SUAREZ, EXAMINING ATTORNEY

SN 85-050,367. DILL AIR CONTROL PRODUCTS, LLC, OXFORD, NC. FILED 5-28-2010.

2000K

THE MARK CONSISTS OF STANDARD CHARACTERS WITHOUT CLAIM TO ANY PARTICULAR FONT, STYLE, SIZE, OR COLOR.

SEC. 2(F).

FOR KITS COMPOSED OF REPLACEMENT PARTS TO SERVICE VEHICLES WITH TIRE-PRESSURE MOUNTING-SYSTEMS (TPMS) SENSORS, NAMELY, SEALING VALVE CAPS, DYNAMIC ELECTROLESS NICKEL-PLATED VALVE CORES, ANODIZED ALUMINUM HEX CUTS, RIM SEAL GROMMETS AND WASHERS (U.S. CLS. 21, 23, 26, 36 AND 38).

FIRST USE 2-28-2006; IN COMMERCE 2-28-2006.

MARIA-VICTORIA SUAREZ, EXAMINING ATTORNEY

SN 85-050,376. DILL AIR CONTROL PRODUCTS, LLC, OXFORD, NC. FILED 5-28-2010.

1100K

THE MARK CONSISTS OF STANDARD CHARACTERS WITHOUT CLAIM TO ANY PARTICULAR FONT, STYLE, SIZE, OR COLOR.

SEC. 2(F).

FOR KITS COMPOSED OF REPLACEMENT PARTS TO SERVICE VEHICLES WITH TIRE-PRESSURE MOUNTING-SYSTEMS (TPMS) SENSOR, NAMELY, SEALING VALVE CAPS, DYNAMIC ELECTROLESS NICKEL-PLATED VALVE CORES, ANODIZED ALUMINUM HEX CUTS, RIM SEAL GROMMETS AND WASHERS (U.S. CLS. 21, 23, 26, 36 AND 38).

FIRST USE 2-28-2006; IN COMMERCE 2-28-2006.

MARIA-VICTORIA SUAREZ, EXAMINING ATTORNEY

CLASS 9—(Continued).

SN 85-050,388. DILL AIR CONTROL PRODUCTS, LLC, OXFORD, NC. FILED 5-28-2010.

1070K

THE MARK CONSISTS OF STANDARD CHARACTERS WITHOUT CLAIM TO ANY PARTICULAR FONT, STYLE, SIZE, OR COLOR.

SEC. 2(F).

FOR KITS COMPOSED OF REPLACEMENT PARTS TO SERVICE VEHICLES WITH TIRE-PRESSURE MOUNTING-SYSTEM (TPMS) SENSORS, NAMELY, SEALING VALVE CAPS, DYNAMIC ELECTROLESS NICKEL-PLATED VALVE CORES, ANODIZED ALUMINUM HEX CUTS, RIM SEAL GROMMETS AND WASHERS (U.S. CLS. 21, 23, 26, 36 AND 38).

FIRST USE 2-28-2006; IN COMMERCE 2-28-2006.

MARIA-VICTORIA SUAREZ, EXAMINING ATTORNEY

SN 85-050,673. THE AMERICAN EDUCATION CORPORATION, OKLAHOMA CITY, OK. FILED 5-28-2010.

A+ VLabs

THE MARK CONSISTS OF STANDARD CHARACTERS WITHOUT CLAIM TO ANY PARTICULAR FONT, STYLE, SIZE, OR COLOR.

OWNER OF U.S. REG. NOS. 1,535,032, 3,619,318 AND OTHERS.

NO CLAIM IS MADE TO THE EXCLUSIVE RIGHT TO USE "VLABS", APART FROM THE MARK AS SHOWN.

FOR EDUCATIONAL SOFTWARE FEATURING INSTRUCTION IN SCIENCE, NAMELY, THROUGH THE USE OF VIRTUAL LABORATORY EXPERIMENTS (U.S. CLS. 21, 23, 26, 36 AND 38).

FIRST USE 4-27-2010; IN COMMERCE 4-27-2010.

ELIZABETH HUGHITT, EXAMINING ATTORNEY

SN 85-056,195. VISUAL WORLD PRODUCTS, LLC, AKA VWP, FAIRFIELD, CT. FILED 6-7-2010.

Visual World Products

THE MARK CONSISTS OF STANDARD CHARACTERS WITHOUT CLAIM TO ANY PARTICULAR FONT, STYLE, SIZE, OR COLOR.

NO CLAIM IS MADE TO THE EXCLUSIVE RIGHT TO USE "VISUAL" OR "PRODUCTS", APART FROM THE MARK AS SHOWN.

FOR 3-D GLASSES, 3-D EYEWEAR (U.S. CLS. 21, 23, 26, 36 AND 38).

FIRST USE 1-21-2010; IN COMMERCE 5-21-2010.

FONG HSU, EXAMINING ATTORNEY

CLASS 9—(Continued).

SN 85-064,206. TEXAS EDUCATION AGENCY, AUSTIN, TX. FILED 6-16-2010.

STAAR

THE MARK CONSISTS OF STANDARD CHARACTERS WITHOUT CLAIM TO ANY PARTICULAR FONT, STYLE, SIZE, OR COLOR.

FOR COMPUTER SOFTWARE FOR USE IN THE ASSESSMENT OF THE EDUCATIONAL DEVELOPMENT IN CHILDREN (U.S. CLS. 21, 23, 26, 36 AND 38).

GINA HAYES, EXAMINING ATTORNEY

SN 85-067,731. OLYMPUS CORPORATION, TOKYO, JAPAN, FILED 6-21-2010.

38DLP

THE MARK CONSISTS OF STANDARD CHARACTERS WITHOUT CLAIM TO ANY PARTICULAR FONT, STYLE, SIZE, OR COLOR.

FOR NONDESTRUCTIVE TESTING INSTRUMENTS, NAMELY, ULTRASONIC THICKNESS GAUGES, NAMELY, PRECISION THICKNESS GAUGES AND CORROSION THICKNESS GAUGES; ULTRASOUND PRODUCTS AND INSTRUMENTS, NAMELY, ULTRASONIC INSPECTION DEVICES AND PROBES FOR NON-MEDICAL, NON-DESTRUCTIVE TESTING; AND ULTRASONIC TESTING PRODUCTS AND INSTRUMENTS, NAMELY, ULTRASONIC THICKNESS TESTERS AND HARDNESS TESTERS, FOR NON-MEDICAL USE (U.S. CLS. 21, 23, 26, 36 AND 38).

RON FAIRBANKS, EXAMINING ATTORNEY

SN 85-067,890. TALYST INC., BELLEVUE, WA. FILED 6-21-2010.

AUTOCAROUSEL

THE MARK CONSISTS OF STANDARD CHARACTERS WITHOUT CLAIM TO ANY PARTICULAR FONT, STYLE, SIZE, OR COLOR.

OWNER OF U.S. REG. NOS. 2,764,746, 3,252,802 AND 3,253,698.

SEC. 2(F).

FOR INVENTORY CONTROL AND STORAGE SYSTEM, NAMELY, MACHINES FOR DISPENSING PRE-DETERMINED DOSAGES OF MEDICATION COMPRISED OF HARDWARE AND SOFTWARE, SPECIALLY ADAPTED FOR THE STORAGE AND TRACKING OF MEDICATION (U.S. CLS. 21, 23, 26, 36 AND 38).

FIRST USE 6-0-2006; IN COMMERCE 6-0-2006.

HEATHER THOMPSON, EXAMINING ATTORNEY

CLASS 9—(Continued).

SN 85-073,120. CONTROL SYSTEMS INTERNATIONAL, INC., LENEXA, KS. FILED 6-28-2010.

The logo for FUEL FACS+ features the word "FUEL" in a bold, sans-serif font above the word "FACS+" in a similar font. A stylized square graphic with a curved line is positioned to the left of the "F" in "FACS+".

OWNER OF U.S. REG. NOS. 1,458,106 AND 2,442,482. NO CLAIM IS MADE TO THE EXCLUSIVE RIGHT TO USE "FUEL", APART FROM THE MARK AS SHOWN.

THE MARK CONSISTS OF THE WORDING "FUEL FACS" APPEARING IN STYLIZED FONT WITH A PLUS SIGN APPEARING AFTER THE "S" IN "FACS". THERE IS A SQUARE WITH ROUND CORNERS THAT APPEARS BE- NEATH THE "F" IN "FUEL". THE SQUARE HAS A CURVED LINE APPEARING THROUGH THE SQUARE RUNNING FROM THE LOWER LEFT CORNER OF THE SQUARE TO ABOVE THE TOP RIGHT CORNER OF THE SQUARE.

FOR COMPUTER ACCOUNTING AND CONTROL SYSTEMS COMPRISING COMPUTERS, COMPUTER OPERATING PROGRAMS AND ELECTRICAL CONTROL- LERS IN THE FIELD OF LIQUID STORAGE AND DISTRIBUTION (U.S. CLS. 21, 23, 26, 36 AND 38).

FIRST USE 2-4-2010; IN COMMERCE 2-4-2010.

CHRISTINE MARTIN, EXAMINING ATTORNEY

SN 85-085,393. ARISTOCRAT TECHNOLOGIES AUSTRALIA PTY LTD., NORTH RYDE, NSW, AUSTRALIA, FILED 7-15-2010.

JIMMY B. GOLD

THE MARK CONSISTS OF STANDARD CHARACTERS WITHOUT CLAIM TO ANY PARTICULAR FONT, STYLE, SIZE, OR COLOR.

PRIORITY CLAIMED UNDER SEC. 44(D) ON AUSTRALIA APPLICATION NO. 1344467, FILED 2-9-2010, REG. NO. 1344467, DATED 2-9-2010, EXPIRES 2-9-2020.

THE NAME(S), PORTRAIT(S), AND/OR SIGNATURE(S) SHOWN IN THE MARK DOES NOT IDENTIFY A PARTICULAR LIVING INDIVIDUAL.

FOR ELECTRONIC GAMING MACHINES, NAMELY, DEVICES WHICH ACCEPT A WAGER (U.S. CLS. 21, 23, 26, 36 AND 38).

BILL DAWE, EXAMINING ATTORNEY

CLASS 9—(Continued).

SN 85-087,082. SALZENBERG, CHARLES H., JR, EL DORADO HILLS, CA. FILED 7-17-2010.



THE COLOR(S) RED, PURPLE, YELLOW, GREEN, BLACK IS/ARE CLAIMED AS A FEATURE OF THE MARK. THE MARK CONSISTS OF RED LETTERS OUTLINED IN PURPLE, A BRIGHT GREEN MEDICAL MARIJUANA LEAF WITH A YELLOW HAPPY FACE, BLACK EYES AND SMILE SITS OVER THE LETTER "I".

FOR COMPUTER GAME SOFTWARE DOWNLOADABLE FROM A GLOBAL COMPUTER NETWORK; COMPUTER GAME SOFTWARE FOR PERSONAL COMPUTERS AND HOME VIDEO GAME CONSOLES; COMPUTER GAME SOFTWARE FOR USE ON MOBILE AND CELLULAR PHONES; COMPUTER GAME SOFTWARE FOR USE WITH PERSONAL COMPUTERS, HOME VIDEO GAME CONSOLES USED WITH TELEVISIONS, AND FOR ARCADE-BASED VIDEO GAME CONSOLES; DOWNLOADABLE COMPUTER GAME SOFTWARE VIA A GLOBAL COMPUTER NETWORK AND WIRELESS DEVICES; DOWNLOADABLE IMAGE FILE CONTAINING ARTWORK, TEXT, AUDIO, VIDEO, GAMES AND INTERNET WEB LINKS RELATING TO SPORTING AND CULTURAL ACTIVITIES; DOWNLOADABLE MULTIMEDIA FILE CONTAINING ARTWORK, TEXT, AUDIO, VIDEO, GAMES, AND INTERNET WEB LINKS RELATING TO SOCIAL CAUSES; DOWNLOADABLE VIRTUAL GOODS, NAMELY, COMPUTER PROGRAMS FEATURING GAME PIECES FOR USE IN ONLINE VIRTUAL WORLDS; DOWNLOADABLE GAMES, SOFTWARE, MUSIC VIA THE INTERNET AND WIRELESS DEVICES; ELECTRONIC GAME SOFTWARE FOR CELLULAR TELEPHONES; ELECTRONIC GAME SOFTWARE FOR HANDHELD ELECTRONIC DEVICES (U.S. CLS. 21, 23, 26, 36 AND 38).

FIRST USE 12-20-2009; IN COMMERCE 12-29-2009.
ROBERT STRUCK, EXAMINING ATTORNEY

SN 85-103,945. INDIAN HILL MEDIA INC., DBA MIXERS INC., CLAREMONT, CA. FILED 8-10-2010.

Mixers

THE MARK CONSISTS OF STANDARD CHARACTERS WITHOUT CLAIM TO ANY PARTICULAR FONT, STYLE, SIZE, OR COLOR.

FOR AUDIO AND VIDEO RECORDINGS FEATURING MUSIC AND ARTISTIC PERFORMANCES (U.S. CLS. 21, 23, 26, 36 AND 38).

FIRST USE 3-27-2004; IN COMMERCE 8-1-2010.
PRISCILLA MILTON, EXAMINING ATTORNEY

CLASS 9—(Continued).

SN 85-106,536. REDROVER LABS, LLC, NEW YORK, NY. FILED 8-12-2010.

REDROVER

THE MARK CONSISTS OF STANDARD CHARACTERS WITHOUT CLAIM TO ANY PARTICULAR FONT, STYLE, SIZE, OR COLOR.

FOR COMPUTER SOFTWARE, NAMELY, COMPUTER APPLICATION SOFTWARE FOR COMPUTERS AND MOBILE DEVICES, NAMELY, MOBILE PHONES, NAMELY, SOFTWARE FOR CONNECTING AND COMMUNICATING WITH COMPUTER NETWORK USERS WHICH ARE FRIENDS AND COLLEAGUES (U.S. CLS. 21, 23, 26, 36 AND 38).

WARREN L. OLANDRIA, EXAMINING ATTORNEY

SN 85-109,602. ENFORA, INC., RICHARDSON, TX. FILED 8-17-2010.

N4A

THE MARK CONSISTS OF STANDARD CHARACTERS WITHOUT CLAIM TO ANY PARTICULAR FONT, STYLE, SIZE, OR COLOR.

FOR WIRELESS NETWORKING DEVICES, NAMELY, RADIO MODULES AND MODEMS, INCLUDING RADIO MODULES AND MODEMS INCORPORATING WIRELESS NETWORKING SOFTWARE; SERVER SOFTWARE, NAMELY, SOFTWARE FOR CONFIGURING AND MANAGING WIRELESS NETWORKING DEVICES, NAMELY, RADIO MODULES AND MODEMS (U.S. CLS. 21, 23, 26, 36 AND 38).

SUSAN RICHARDS, EXAMINING ATTORNEY

SN 85-111,794. GREENDISK, INC., ISSAQUAH, WA. FILED 8-19-2010.



THE MARK CONSISTS OF STYLIZED DESIGN FOR THE WORD "GREENDISK", INCLUDING A STYLIZED "G" WITHIN A BACKGROUND REPRESENTATION OF A DISKETTE AND INCLUDING A CAPITAL "D" AND INCLUDING A STYLIZED "I".

FOR BLANK AND PRE-FORMATTED DISKETTES, COMPACT DISKS AND DVDS, MADE FROM RECYCLED MATERIAL, AND CASES FOR DISKETTES, COMPACT DISKS AND DVDS, BOTH HARD SHELL AND SOFT SHELL, MADE FROM RECYCLED MATERIAL (U.S. CLS. 21, 23, 26, 36 AND 38).

FIRST USE 12-15-1993; IN COMMERCE 12-15-1993.
GINA HAYES, EXAMINING ATTORNEY

CLASS 9—(Continued).

SN 85-112,291. CIRRASCALE CORPORATION, SAN DIEGO, CA. FILED 8-20-2010.



THE MARK CONSISTS OF ARTFUL RENDERINGS OF THREE VERTICAL COMPUTER BLADES TO THE LEFT OF THE WORD "CIRRASCALE".

FOR BLADE-BASED AND RACK MOUNTED COMPUTERS, NAMELY, STORAGE COMPUTERS, COMPUTE COMPUTERS, AND GENERAL PURPOSE COMPUTERS; BLADE-BASED AND RACK-MOUNTED COMPUTER NETWORK SWITCHES, ETHERNET AGGREGATORS, INFINIBAND AGGREGATORS, AND MYRINET AGGREGATORS; BLADE-BASED MOUNTING RACKS, NAMELY, STORAGE RACKS FOR BLADE-BASED COMPUTERS, NETWORK SWITCHES AND AGGREGATORS, COOLING, MANAGEMENT AND POWER SYSTEMS; SOFTWARE FOR INTEGRATING AND OPERATING BLADE BASED AND RACK MOUNTED COMPUTERS; PORTABLE DATA CENTERS, NAMELY, CONTAINERS HAVING BLADE-BASED RACKS, RACK MOUNTED COMPUTERS, BLADE-BASED COMPUTERS AND COOLING, MANAGEMENT, AND POWER SYSTEMS (U.S. CLS. 21, 23, 26, 36 AND 38).

MICHAEL WEBSTER, EXAMINING ATTORNEY

SN 85-112,719. KHALSA, KARTA P. S., SUNNYVALE, CA. FILED 8-20-2010.

VELOCITY CIRCUITS

THE MARK CONSISTS OF STANDARD CHARACTERS WITHOUT CLAIM TO ANY PARTICULAR FONT, STYLE, SIZE, OR COLOR.

NO CLAIM IS MADE TO THE EXCLUSIVE RIGHT TO USE "CIRCUITS", APART FROM THE MARK AS SHOWN.

FOR CUSTOM PRINTED CIRCUIT BOARDS (U.S. CLS. 21, 23, 26, 36 AND 38).

TINA BROWN, EXAMINING ATTORNEY

SN 85-113,112. OPTIMAL SATCOM, INC., RESTON, VA. FILED 8-23-2010.

CLBT

THE MARK CONSISTS OF STANDARD CHARACTERS WITHOUT CLAIM TO ANY PARTICULAR FONT, STYLE, SIZE, OR COLOR.

FOR COMPUTER SOFTWARE FOR PERFORMING SATELLITE LINK CALCULATIONS (U.S. CLS. 21, 23, 26, 36 AND 38).

FIRST USE 10-30-2003; IN COMMERCE 10-30-2003.

MATTHEW PAPPAS, EXAMINING ATTORNEY

CLASS 9—(Continued).

SN 85-113,710. 911 DATAMASTER, INC., OVERLAND PARK, KS. FILED 8-23-2010.



NO CLAIM IS MADE TO THE EXCLUSIVE RIGHT TO USE "DATA", APART FROM THE MARK AS SHOWN.

THE COLOR(S) BLUE AND RED IS/ARE CLAIMED AS A FEATURE OF THE MARK.

THE MARK CONSISTS OF A SQUARE COMPRISED OF NINE INDIVIDUAL BLOCKS, WITH THE FIRST BLOCK IN THE TOP LEFT CORNER AND THE LAST BLOCK IN THE BOTTOM RIGHT CORNER IN RED AND THE REMAINING BLOCKS IN BLUE. IMMEDIATELY TO THE RIGHT OF THE BLOCKS IS THE WORD "DATABOND" WITH THE WORD "DATA" IN BLUE AND THE WORD "BOND" IN RED.

FOR COMPUTER APPLICATION SOFTWARE, CONSISTING OF DATABASE AND DATABASE MANAGEMENT SOFTWARE, SOLD AS A UNIT, FOR USE WITHIN PUBLIC SAFETY AND EMERGENCY RESPONSE THAT PROVIDES FOR PROVISIONING AND MAINTENANCE OF CUSTOMER LOCATION DATA (U.S. CLS. 21, 23, 26, 36 AND 38).

KATHERINE M. DUBRAY, EXAMINING ATTORNEY

SN 85-113,715. 911 DATAMASTER, INC., OVERLAND PARK, KS. FILED 8-23-2010.



NO CLAIM IS MADE TO THE EXCLUSIVE RIGHT TO USE "DATA", APART FROM THE MARK AS SHOWN.

THE COLOR(S) BLUE AND RED IS/ARE CLAIMED AS A FEATURE OF THE MARK.

THE MARK CONSISTS OF A SQUARE COMPRISED OF NINE INDIVIDUAL BLOCKS, WITH THE FIRST BLOCK IN THE TOP LEFT CORNER AND THE LAST BLOCK IN THE BOTTOM RIGHT CORNER IN RED AND THE REMAINING BLOCKS IN BLUE. IMMEDIATELY TO THE RIGHT OF THE BLOCKS IS THE WORD "DATANEXUS" WITH THE WORD "DATA" IN BLUE AND THE WORD "NEXUS" IN RED.

FOR COMPUTER APPLICATION SOFTWARE, CONSISTING OF DATABASE AND DATABASE MANAGEMENT SOFTWARE, SOLD AS A UNIT, FOR USE WITHIN PUBLIC SAFETY AND EMERGENCY RESPONSE THAT PROVIDES FOR BOTH SYSTEMATIC AND MANUAL RELATIONSHIP MANAGEMENT OF U. S. POSTAL SERVICE AND MASTER STREET ADDRESS GUIDE DATA (U.S. CLS. 21, 23, 26, 36 AND 38).

KATHERINE M. DUBRAY, EXAMINING ATTORNEY

CLASS 9—(Continued).

SN 85-114,043. BIKINI WATERS OF AMERICA, INC., MAUMELLE, AR. FILED 8-23-2010.

**Bikini Waters of America,
Inc.**

THE MARK CONSISTS OF STANDARD CHARACTERS WITHOUT CLAIM TO ANY PARTICULAR FONT, STYLE, SIZE, OR COLOR.

NO CLAIM IS MADE TO THE EXCLUSIVE RIGHT TO USE "AMERICA, INC.", APART FROM THE MARK AS SHOWN.

FOR SUNGLASSES (U.S. CLS. 21, 23, 26, 36 AND 38).
FIRST USE 2-17-2005; IN COMMERCE 2-17-2005.
KIM SAITO, EXAMINING ATTORNEY

SN 85-115,188. CODET INC., COATICOOK, QUEBEC, CANADA, FILED 8-25-2010.



NO CLAIM IS MADE TO THE EXCLUSIVE RIGHT TO USE "FLAME" AND "FR", APART FROM THE MARK AS SHOWN.

THE COLOR(S) RED, BLACK AND WHITE IS/ARE CLAIMED AS A FEATURE OF THE MARK.

THE MARK CONSISTS OF THE WORD AND LETTERS "FLAME X FR" WITHIN A SHIELD SHAPE OUTLINED IN BLACK, WITH THE WORD AND LETTERS "FLAME FR" IN BLACK, THE LETTER "X" IN WHITE OUTLINED IN BLACK WITHIN A RECTANGULAR SHAPE IN RED WITHIN THE SHIELD SHAPE.

FOR PROTECTIVE AND FLAME-RESISTANT CLOTHING, NAMELY, PROTECTIVE AND FLAME-RESISTANT COVERALLS, SHIRTS, PANTS, T-SHIRTS, POLOS, JACKETS AND OVERALLS (U.S. CLS. 21, 23, 26, 36 AND 38).

ARETHA SOMERVILLE, EXAMINING ATTORNEY

CLASS 9—(Continued).

SN 85-119,105. LUMENSION SECURITY, INC., SCOTTSDALE, AZ. FILED 8-30-2010.

INTELLIGENT WHITELISTING

THE MARK CONSISTS OF STANDARD CHARACTERS WITHOUT CLAIM TO ANY PARTICULAR FONT, STYLE, SIZE, OR COLOR.

NO CLAIM IS MADE TO THE EXCLUSIVE RIGHT TO USE "WHITELISTING", APART FROM THE MARK AS SHOWN.

FOR COMPUTER SOFTWARE THAT COMBINES ANTIVIRUS, APPLICATION CONTROL AND PATCH MANAGEMENT APPLICATIONS INTO A SEAMLESS WORKFLOW ON A SINGLE CONSOLE FOR THE PURPOSE OF IDENTIFYING SPECIAL CHARACTERISTICS AND ACCEPTABILITY OF OTHER COMPUTER SOFTWARE (U.S. CLS. 21, 23, 26, 36 AND 38).
DAVID TAYLOR, EXAMINING ATTORNEY

SN 85-119,665. MOLINE, RICH, DBA ITRACKER, TEMECULA, CA. FILED 8-31-2010.



NO CLAIM IS MADE TO THE EXCLUSIVE RIGHT TO USE "INVENTORY CONTROL SOFTWARE", APART FROM THE MARK AS SHOWN.

THE MARK CONSISTS OF LARGE "i" LOGO IN FRONT OF THE STYLIZED WORDING "ITRACKER". BENEATH THE WORDING, THE PHRASE "INVENTORY CONTROL SOFTWARE SOLUTIONS" APPEARS IN STYLIZED FONT.

FOR COMPUTER SOFTWARE THAT PROVIDES REAL-TIME, INTEGRATED BUSINESS MANAGEMENT INTELLIGENCE BY COMBINING INFORMATION FROM VARIOUS DATABASES AND PRESENTING IT IN AN EASY-TO-UNDERSTAND USER INTERFACE (U.S. CLS. 21, 23, 26, 36 AND 38).

MARILYN IZZI, EXAMINING ATTORNEY

CLASS 9—(Continued).

SN 85-121,229. FORMFAST, INC., DES PERES, MO. FILED 9-1-2010.

IMPROVING THE BUSINESS OF
HEALTHCARE

THE MARK CONSISTS OF STANDARD CHARACTERS WITHOUT CLAIM TO ANY PARTICULAR FONT, STYLE, SIZE, OR COLOR.

FOR COMPUTER SOFTWARE FOR USE IN WORKFLOW AUTOMATION, FORMS GENERATION, OUTPUT MANAGEMENT, DOCUMENT MANAGEMENT, AND REPORTS GENERATION IN THE MEDICAL AND HEALTH CARE INDUSTRIES (U.S. CLS. 21, 23, 26, 36 AND 38).

KRISTIN DAHLING, EXAMINING ATTORNEY

SN 85-122,205. TUNEUP SOFTWARE GMBH, DARMSTADT, FED REP GERMANY, FILED 9-2-2010.

TuneUp Programs-on-Demand
Technology

THE MARK CONSISTS OF STANDARD CHARACTERS WITHOUT CLAIM TO ANY PARTICULAR FONT, STYLE, SIZE, OR COLOR.

PRIORITY CLAIMED UNDER SEC. 44(D) ON ERP NCNTY TM OFC APPLICATION NO. 009248981, FILED 7-15-2010, REG. NO. 009248981, DATED 12-27-2010, EXPIRES 7-15-2020.

OWNER OF U.S. REG. NO. 2,816,272.

NO CLAIM IS MADE TO THE EXCLUSIVE RIGHT TO USE "PROGRAMS-ON-DEMAND TECHNOLOGY", APART FROM THE MARK AS SHOWN.

FOR COMPUTER SOFTWARE FOR COMPUTER SYSTEM AND APPLICATION DEPLOYMENT AND MANAGEMENT, NAMELY, COMPUTER SOFTWARE THAT ALLOWS A USER TO TEMPORARILY DEACTIVATE AND RE-ACTIVATE OTHER COMPUTER PROGRAMS INSTALLED ON A COMPUTER, WITHOUT HAVING TO UNINSTALL AND RE-INSTALL SUCH OTHER COMPUTER PROGRAMS (U.S. CLS. 21, 23, 26, 36 AND 38).

ANNE FARRELL, EXAMINING ATTORNEY

CLASS 9—(Continued).

SN 85-123,862. INTEGRA ENCLOSURES, LIMITED, MENTOR, OH. FILED 9-7-2010.

Integra Enclosures

THE MARK CONSISTS OF STANDARD CHARACTERS WITHOUT CLAIM TO ANY PARTICULAR FONT, STYLE, SIZE, OR COLOR.

NO CLAIM IS MADE TO THE EXCLUSIVE RIGHT TO USE "ENCLOSURES", APART FROM THE MARK AS SHOWN.

FOR THERMOPLASTIC ENCLOSURES, NAMELY, JUNCTION BOXES AND CUT-OUT BOXES WHICH ARE JUNCTION TYPE BOXES WITH HINGES, DESIGNED FOR USE IN ELECTRICAL CONSTRUCTION, WATER TREATMENT, CAR WASH, TELECOMMUNICATION, INSTRUMENTATION, UTILITY, MACHINE BUILDING, AND HVAC, AND ARE NON-CORROSIVE, NON-CONDUCTIVE AND EASY TO INSTALL AND MODIFY (U.S. CLS. 21, 23, 26, 36 AND 38).

FIRST USE 5-1-1999; IN COMMERCE 5-1-1999.

WARREN L. OLANDRIA, EXAMINING ATTORNEY

SN 85-123,942. ABEL BIS RAT, WOODBRIDGE, VA. FILED 9-7-2010.

Voice Status

THE MARK CONSISTS OF STANDARD CHARACTERS WITHOUT CLAIM TO ANY PARTICULAR FONT, STYLE, SIZE, OR COLOR.

NO CLAIM IS MADE TO THE EXCLUSIVE RIGHT TO USE "VOICE", APART FROM THE MARK AS SHOWN.

FOR COMPUTER APPLICATION SOFTWARE FOR MOBILE PHONES, NAMELY, SOFTWARE FOR ELECTRONIC STORAGE OF DATA AND AUDIO INPUTS; COMPUTER APPLICATION SOFTWARE FOR MOBILE PHONES AND DEVICES, NAMELY, SOFTWARE FOR ELECTRONIC STORAGE OF DATA AND AUDIO INPUTS; COMPUTER GAME SOFTWARE FOR USE ON MOBILE AND CELLULAR PHONES; COMPUTER SOFTWARE FOR APPLICATION AND DATABASE INTEGRATION; COMPUTER SOFTWARE FOR MANIPULATING DIGITAL AUDIO INFORMATION FOR USE IN AUDIO MEDIA APPLICATIONS (U.S. CLS. 21, 23, 26, 36 AND 38).

CAROLINE WOOD, EXAMINING ATTORNEY

CLASS 9—(Continued).

SN 85-126,720. HANGZHOU SANFORD TOOLS CO., LTD, HANG ZHOU, CHINA, FILED 9-10-2010.



THE COLOR(S) WHITE, GRAY, AND BLACK IS/ARE CLAIMED AS A FEATURE OF THE MARK.

THE MARK CONSISTS OF THE STYLIZED WORDING "CASAR", EACH LETTER BEING IN THE COLORS WHITE AND DIAGONAL GRADIENT GRAY GIVING A METALLIC, WAVE-LIKE EFFECT, AND A BLACK LETTER OUTLINE.

THE ENGLISH TRANSLATION OF "CASAR" IN THE MARK IS "MARRY".

FOR ELECTRIC DOOR OPENERS (U.S. CLS. 21, 23, 26, 36 AND 38).

FIRST USE 12-27-2007; IN COMMERCE 5-29-2009.

KATHERINE M. DUBRAY, EXAMINING ATTORNEY

CLASS 9—(Continued).

SN 85-128,228. CAREFUSION 303, INC., SAN DIEGO, CA. FILED 9-13-2010.

Pyxis SpecialtyStation

THE MARK CONSISTS OF STANDARD CHARACTERS WITHOUT CLAIM TO ANY PARTICULAR FONT, STYLE, SIZE, OR COLOR.

OWNER OF U.S. REG. NO. 1,813,422.

NO CLAIM IS MADE TO THE EXCLUSIVE RIGHT TO USE "SPECIALTY STATION", APART FROM THE MARK AS SHOWN.

FOR AUTOMATED MACHINES FOR DISPENSING DOSAGES OF MEDICINE AND MEDICAL SUPPLIES; COMPUTER HARDWARE AND SOFTWARE FOR MEDICATION ORDER MANAGEMENT, AND FOR SECURING, TRACKING, MONITORING AND REPLENISHMENT OF MEDICINE AND MEDICAL SUPPLIES FOR MEDICINE AND MEDICAL SUPPLY DISPENSING MACHINES (U.S. CLS. 21, 23, 26, 36 AND 38).

FIRST USE 12-0-2009; IN COMMERCE 12-0-2009.

MELISSA VALLILLO, EXAMINING ATTORNEY

SN 85-126,889. BARRIER1, LLC, RAMSEY, MN. FILED 9-10-2010.

BARRIER1

THE MARK CONSISTS OF STANDARD CHARACTERS WITHOUT CLAIM TO ANY PARTICULAR FONT, STYLE, SIZE, OR COLOR.

FOR COMPUTER HARDWARE FOR MONITORING COMMUNICATIONS AND NETWORKS FOR USE IN COMPUTER NETWORK SECURITY (U.S. CLS. 21, 23, 26, 36 AND 38).

FIRST USE 8-3-2009; IN COMMERCE 8-3-2009.

CIMMERIAN COLEMAN, EXAMINING ATTORNEY

SN 85-128,253. CAREFUSION 303, INC., SAN DIEGO, CA. FILED 9-13-2010.

Pyxis OncologyStation

THE MARK CONSISTS OF STANDARD CHARACTERS WITHOUT CLAIM TO ANY PARTICULAR FONT, STYLE, SIZE, OR COLOR.

OWNER OF U.S. REG. NOS. 1,813,422 AND 3,111,970.

FOR AUTOMATED MACHINES FOR DISPENSING DOSAGES OF MEDICINE AND MEDICAL SUPPLIES; COMPUTER HARDWARE AND SOFTWARE FOR MEDICATION ORDER MANAGEMENT, AND FOR SECURING, TRACKING, MONITORING AND REPLENISHMENT OF MEDICINE AND MEDICAL SUPPLIES FOR MEDICINE AND MEDICAL SUPPLY DISPENSING MACHINES (U.S. CLS. 21, 23, 26, 36 AND 38).

FIRST USE 1-31-2004; IN COMMERCE 1-31-2004.

MELISSA VALLILLO, EXAMINING ATTORNEY

CLASS 9—(Continued).

SN 85-128,610. BOLIDE TECHNOLOGY GROUP, INC., SAN DIMAS, CA. FILED 9-13-2010.

iPac

THE MARK CONSISTS OF STANDARD CHARACTERS WITHOUT CLAIM TO ANY PARTICULAR FONT, STYLE, SIZE, OR COLOR.

FOR AUTOMATED SELF CONTAINED ELECTRONIC SURVEILLANCE DEVICES THAT CAN BE DEPLOYED TO GATHER EVIDENCE OR INTELLIGENCE IN REMOTE LOCATIONS; CLOSED CIRCUIT TV SYSTEMS FOR SECURITY AND SURVEILLANCE, NAMELY, CAMERAS, SWITCHERS, MONITORS, MICROPHONES, AND RECORDERS; COMPUTER HARDWARE FOR IP VIDEO SURVEILLANCE; ELECTRIC AND ELECTRONIC VIDEO SURVEILLANCE INSTALLATIONS; INFRARED CAMERAS; IP (INTERNET PROTOCOL) CAMERAS; IP (INTERNET PROTOCOL) SPEED DOME CAMERAS; RECEIVERS OF ELECTRONIC SIGNALS; TRANSMITTERS OF ELECTRONIC SIGNALS; WIRELESS COMMUNICATION DEVICES FOR TRANSMITTING IMAGES TAKEN BY A CAMERA (U.S. CLS. 21, 23, 26, 36 AND 38).

BARNEY CHARLON, EXAMINING ATTORNEY

CLASS 9—(Continued).

SN 85-130,092. REVISION MILITARY S.A.R.L., LUXEMBOURG, LUXEMBOURG, FILED 9-15-2010.

BATLSKIN

THE MARK CONSISTS OF STANDARD CHARACTERS WITHOUT CLAIM TO ANY PARTICULAR FONT, STYLE, SIZE, OR COLOR.

FOR HEAD AND BODY PROTECTIVE EQUIPMENT, NAMELY, HELMETS, FACE SHIELDS, MANDIBLE GUARDS TO PROTECT THE JAW FROM IMPACT FOR MILITARY, LAW ENFORCEMENT, AND SECURITY PERSONNEL, NECK GUARDS TO PROTECT THE NECK FROM IMPACT FOR MILITARY, LAW ENFORCEMENT, AND SECURITY PERSONNEL, AND PROTECTIVE BALLISTIC RESISTANT BODY ARMOR (U.S. CLS. 21, 23, 26, 36 AND 38).

CHRISTOPHER BUONGIORNO, EXAMINING ATTORNEY

SN 85-131,678. OPPORTUNITY HOLDING, LLC, SAN ANTONIO, TX. FILED 9-16-2010.

ARDYSS

SN 85-130,034. SAPPHIRE TECHNOLOGY LTD., SHATIN, NT, HONG KONG, FILED 9-15-2010.

SAPPHIRE EVOLUTION

THE MARK CONSISTS OF STANDARD CHARACTERS WITHOUT CLAIM TO ANY PARTICULAR FONT, STYLE, SIZE, OR COLOR.

OWNER OF U.S. REG. NO. 2,942,912.
FOR PERSONAL COMPUTERS (U.S. CLS. 21, 23, 26, 36 AND 38).

KELLY CHOE, EXAMINING ATTORNEY

THE MARK CONSISTS OF STANDARD CHARACTERS WITHOUT CLAIM TO ANY PARTICULAR FONT, STYLE, SIZE, OR COLOR.

OWNER OF U.S. REG. NOS. 2,768,771, 3,221,455 AND OTHERS.

FOR DIRECT SELLING AIDS, NAMELY, DVD'S FEATURING INFORMATIONAL PRESENTATIONS ABOUT COSMETICS, CLOTHING, HOUSEHOLD CLEANERS, SOAPS, LAUNDRY PREPARATIONS, DIETARY AND/OR FOOD SUPPLEMENTS AND BEVERAGES THAT ARE SOLD TO INDEPENDENT DISTRIBUTORS FOR USE IN SALES TRAINING AND EDUCATION (U.S. CLS. 21, 23, 26, 36 AND 38).

FIRST USE 1-22-2002; IN COMMERCE 1-22-2002.

ALEXANDER L. POWERS, EXAMINING ATTORNEY

CLASS 9—(Continued).

SN 85-132,205. ASSA ABLOY AB, STOCKHOLM, SWEDEN, FILED 9-17-2010.

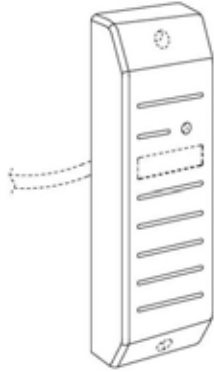

THE MARK CONSISTS OF A THREE DIMENSIONAL CONFIGURATION OF AN RFID READER COMPRISING AN ELONGATE HOUSING WITH A FRONT FACE, TWO SIDE FACES AND A TOP AND BOTTOM. THE FRONT FACE INCLUDES A TOP ANGLED SURFACE AND A BOTTOM ANGLED SURFACE WITH THE SIDE FACES TAPERED AT THE TOP AND BOTTOM AT THE ANGLED PORTIONS OF THE FRONT FACE. ALL FORWARD FACING EDGES BETWEEN SURFACES ARE ROUNDED. SEVEN HORIZONTAL GROOVES ARE FORMED WITHIN THE FRONT FACE WITH THE SECOND GROOVE FROM THE TOP BEING SHORTER WITH A CIRCLE PLACED TO THE RIGHT OF THE SHORTER GROOVE. A GAP IS SET BETWEEN THE BOTTOM FIVE LINES AND THE TOP TWO LINES. THE MATTER SHOWN IN BROKEN OR DOTTED LINES IS NOT PART OF THE MARK AND SERVES ONLY TO SHOW THE POSITION OR PLACEMENT OF THE MARK.

SEC. 2(F).
FOR RADIO FREQUENCY IDENTIFICATION (RFID) READERS (U.S. CLS. 21, 23, 26, 36 AND 38).
FIRST USE 7-1-1992; IN COMMERCE 7-1-1992.
ADA HAN, EXAMINING ATTORNEY

SN 85-132,332. SAPPHIRE TECHNOLOGY LTD., SHATIN, NT, HONG KONG, FILED 9-17-2010.

SAPPHIRE EDGE

THE MARK CONSISTS OF STANDARD CHARACTERS WITHOUT CLAIM TO ANY PARTICULAR FONT, STYLE, SIZE, OR COLOR.

OWNER OF U.S. REG. NO. 2,942,912.
FOR NETTOP COMPUTER, ALL-IN-ONE COMPUTER FEATURING A MINI FORMAT, NAMELY, A CENTRAL PROCESSING UNIT, MAINBOARD, HARD DISK DRIVE, GRAPHICS BOARD, MEMORY, AND A PERSONAL COMPUTER CARRYING CASE (U.S. CLS. 21, 23, 26, 36 AND 38).
KELLY CHOE, EXAMINING ATTORNEY

CLASS 9—(Continued).

SN 85-134,212. ENGENIUM SOLUTIONS, INC., THE WOODLANDS, TX. FILED 9-21-2010.

Engenium

THE MARK CONSISTS OF STANDARD CHARACTERS WITHOUT CLAIM TO ANY PARTICULAR FONT, STYLE, SIZE, OR COLOR.

FOR SOFTWARE FOR COMMERCIAL USE FOR SCHEDULING AND TRACKING THE USE AND MAINTENANCE OF COMMERCIAL EQUIPMENT (U.S. CLS. 21, 23, 26, 36 AND 38).

FIRST USE 4-1-2007; IN COMMERCE 4-1-2007.
REBECCA EISINGER, EXAMINING ATTORNEY

SN 85-134,245. SEIKAKU TECHNICAL GROUP LIMITED, KOWLOON, HONG KONG, FILED 9-21-2010.



OWNER OF U.S. REG. NO. 1,920,755.

THE MARK CONSISTS OF A CIRCLE, WHICH IS SPLIT IN THE MIDDLE BY TWO SHAPES OF MIRRORED SPEAKERS, AND THE WORD "SHOW" IS WRITTEN ON THE SPEAKERS.

FOR MICROPHONES, SOUND MIXERS, RECEIVERS, NAMELY, AUDIO RECEIVERS, VIDEO RECEIVERS AND STEREO RECEIVERS; TRANSMITTERS, NAMELY, AUDIO TRANSMITTERS AND RADIO TRANSMITTERS; PUBLIC ADDRESS AMPLIFIERS, AUDIO AMPLIFIERS, CAR AMPLIFIERS; RADIO RECEIVERS AND TUNERS, SOUND EQUALIZERS, AUDIO TAPE PLAYERS AND RECORDERS; AUDIO MIXERS; PUBLIC ADDRESS AND SOUND SYSTEM ACCESSORIES, NAMELY, MICROPHONE STANDS, SPEAKER STANDS, MICROPHONE CABLES, SPEAKER CABLES, SPEAKER BOXES AND SOUND MIXERS; SOUND MIXERS; SOUND MIXERS WITH INTEGRATED AMPLIFIERS; MEGAPHONES, HORNS FOR LOUDSPEAKERS, SPEAKERS, NAMELY, AUDIO SPEAKERS AND LOUDSPEAKERS; DISCUSSION SYSTEMS COMPRISING MICROPHONES, AUDIO SPEAKERS AND LOUDSPEAKERS, AMPLIFIERS, ELECTRICAL SWITCHGEAR IN THE NATURE OF VOLTAGE BOOSTING DEVICES FOR ELECTRIC POWER LINES, ELECTRICAL CABLES, POWER SUPPLIES AND COMPONENT PARTS FOR THE AFOREMENTIONED GOODS (U.S. CLS. 21, 23, 26, 36 AND 38).

FIRST USE 1-0-1995; IN COMMERCE 1-0-1995.
LAURA HAMMEL, EXAMINING ATTORNEY

CLASS 9—(Continued).

SN 85-134,322. EAGLE CELL, INC., CITY OF INDUSTRY, CA. FILED 9-21-2010.



THE MARK CONSISTS OF A STYLIZED "E" ENCLOSED BETWEEN TWO WINGS DESIGN.

FOR ACCESSORIES SPECIFICALLY FOR USE WITH CELLULAR PHONES, PERSONAL DIGITAL ASSISTANTS AND PERSONAL DIGITAL AUDIO VIDEO PLAYERS, NAMELY, PROTECTIVE CASES FOR CELL PHONES, PERSONAL DIGITAL ASSISTANTS AND PORTABLE PERSONAL DIGITAL AUDIO-VIDEO PLAYERS; BATTERIES; HANDS FREE AUDIO DEVICES IN THE NATURE OF DEVICES FOR HANDS-FREE USE OF MOBILE PHONES; BATTERY CHARGERS; DATA CABLES IN THE NATURE OF ELECTRIC CABLES FOR TRANSMISSION OF SOUNDS AND IMAGES BETWEEN PHONES, MOBILE PHONES AND COMPUTERS; IN-CAR HOLDERS FOR CELLULAR PHONES, PERSONAL DIGITAL ASSISTANTS AND PORTABLE PERSONAL DIGITAL AUDIO-VIDEO PLAYERS; SCREEN PROTECTORS FOR ELECTRONIC PRODUCTS WITH SCREENS; CARRYING CASES FOR CELL PHONES IN THE NATURE OF CELL PHONE POUCHES; STYLUS PEN FOR USE WITH PORTABLE COMPUTERS AND PERSONAL DIGITAL ASSISTANTS; PORTABLE AUDIO SPEAKER; PORTABLE AMPLIFIER; HAND STRAP IN THE NATURE OF STRAPS FOR MOBILE PHONES; USB BLANK FLASH DRIVE (U.S. CLS. 21, 23, 26, 36 AND 38).
FIRST USE 7-15-2010; IN COMMERCE 7-15-2010.

ANDREA K. NADELMAN, EXAMINING ATTORNEY

SN 85-134,719. MOON PRODUCTS, LLC, SALT LAKE CITY, UT. FILED 9-21-2010.

MALOLO

THE MARK CONSISTS OF STANDARD CHARACTERS WITHOUT CLAIM TO ANY PARTICULAR FONT, STYLE, SIZE, OR COLOR.

FOR AUDIO RECORDINGS AND VIDEO RECORDINGS FEATURING INFORMATION RELATED TO HEALTH, WELLNESS, STRESS MANAGEMENT, AND EXERCISE (U.S. CLS. 21, 23, 26, 36 AND 38).

JAMES LOVELACE, EXAMINING ATTORNEY

CLASS 9—(Continued).

SN 85-134,960. MVR ANALYTICS LLC, BIRMINGHAM, AL. FILED 9-21-2010.

MVOptimizeR

THE MARK CONSISTS OF STANDARD CHARACTERS WITHOUT CLAIM TO ANY PARTICULAR FONT, STYLE, SIZE, OR COLOR.

FOR COMPUTER SOFTWARE FOR PROVIDING AN ON-LINE DATABASE IN THE FIELD OF TRANSACTION PROCESSING TO UPLOAD TRANSACTIONAL DATA, PROVIDE STATISTICAL ANALYSIS, AND PRODUCE NOTIFICATIONS AND REPORTS (U.S. CLS. 21, 23, 26, 36 AND 38).

FIRST USE 6-1-2010; IN COMMERCE 6-1-2010.

JILL C. ALT, EXAMINING ATTORNEY

SN 85-135,596. CRESTRON ELECTRONICS INC., ROCKLEIGH, NJ. FILED 9-22-2010.

3-Series

THE MARK CONSISTS OF STANDARD CHARACTERS WITHOUT CLAIM TO ANY PARTICULAR FONT, STYLE, SIZE, OR COLOR.

FOR ELECTRONIC CONTROL PROCESSORS AND REMOTE CONTROLS FOR MULTIMEDIA DEVICES, HOME THEATER SYSTEMS, AND HOME AUTOMATION SYSTEMS FOR LIGHTING, AUDIO/VIDEO, HVAC, SECURITY, COMPUTERS, APPLIANCES, WATER, AND SHADES (U.S. CLS. 21, 23, 26, 36 AND 38).
CHRISTOPHER BUONGIORNO, EXAMINING ATTORNEY

SN 85-135,651. CRESTRON ELECTRONICS INC., ROCKLEIGH, NJ. FILED 9-22-2010.

3-Series Control System

THE MARK CONSISTS OF STANDARD CHARACTERS WITHOUT CLAIM TO ANY PARTICULAR FONT, STYLE, SIZE, OR COLOR.

NO CLAIM IS MADE TO THE EXCLUSIVE RIGHT TO USE "CONTROL SYSTEM", APART FROM THE MARK AS SHOWN.

FOR ELECTRONIC CONTROL PROCESSORS AND REMOTE CONTROLS FOR MULTIMEDIA DEVICES, HOME THEATER SYSTEMS, AND HOME AUTOMATION SYSTEMS FOR LIGHTING, AUDIO/VIDEO, HVAC, SECURITY, COMPUTERS, APPLIANCES, WATER, AND SHADES (U.S. CLS. 21, 23, 26, 36 AND 38).

CHRISTOPHER BUONGIORNO, EXAMINING ATTORNEY

CLASS 9—(Continued).

SN 85-135,957. ALPHAGRIP, INC., LORTON, VA. FILED 9-22-2010.

SmartGrip

THE MARK CONSISTS OF STANDARD CHARACTERS WITHOUT CLAIM TO ANY PARTICULAR FONT, STYLE, SIZE, OR COLOR.

FOR CASES FOR MOBILE PHONES; CELLULAR PHONES; COMMUNICATIONS COMPUTERS; COMPUTER DOCKING STATION; COMPUTER GAME CONSOLES FOR USE WITH AN EXTERNAL DISPLAY SCREEN OR MONITOR; COMPUTER GAME JOYSTICKS; COMPUTER HARDWARE; COMPUTER KEYBOARDS; COMPUTER KEYPADS; COMPUTER MICE; COMPUTER MOUSE; COMPUTER PERIPHERALS; CORDLESS TELEPHONES; DESK OR CAR MOUNTED UNITS INCORPORATING A LOUDSPEAKER TO ALLOW A TELEPHONE HANDSET TO BE USED HANDSFREE; GAME CONTROLLERS FOR COMPUTER GAMES; HAND HELD JOY STICK UNITS FOR PLAYING VIDEO GAMES; HAND-HELD UNITS FOR PLAYING ELECTRONIC GAMES FOR USE WITH EXTERNAL DISPLAY SCREEN OR MONITOR; HANDHELD COMPUTERS; JOYSTICKS FOR VIDEO GAMES; PERSONAL DIGITAL ASSISTANTS (PDA); REMOTE CONTROLS FOR TELEVISIONS, STEREOS, GAME CONSOLES, APPLIANCES; TABLET COMPUTER; VIDEO GAME CONSOLES FOR USE WITH AN EXTERNAL DISPLAY SCREEN OR MONITOR; VIDEO GAME JOYSTICKS; WEB CONSOLES (U.S. CLS. 21, 23, 26, 36 AND 38).

PAULA MAHONEY, EXAMINING ATTORNEY

SN 85-136,450. ASSA ABLOY AB, STOCKHOLM, SWEDEN, FILED 9-23-2010.

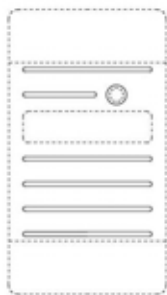

THE MARK CONSISTS OF SIX HORIZONTAL LINES AND A CIRCLE, WHERE THE LINE SECOND FROM THE TOP IS SHORTER THAN THE REMAINING LINES, AND HAS A CIRCLE TO THE RIGHT. THE DOTTED LINES ARE NOT PART OF THE MARK AND SERVE ONLY TO SHOW THE PLACEMENT OF THE MARK UPON THE FRONT OF THE PRODUCT.

SEC. 2(F).
FOR RADIO FREQUENCY IDENTIFICATION (RFID) READERS (U.S. CLS. 21, 23, 26, 36 AND 38).
FIRST USE 5-27-1999; IN COMMERCE 5-27-1999.
ADA HAN, EXAMINING ATTORNEY

CLASS 9—(Continued).

SN 85-139,598. TRANSPARENT HEALTH, LLC, CHICAGO, IL. FILED 9-28-2010.

e-Port

THE MARK CONSISTS OF STANDARD CHARACTERS WITHOUT CLAIM TO ANY PARTICULAR FONT, STYLE, SIZE, OR COLOR.

FOR EDUCATIONAL PORTAL SOFTWARE FOR REPORTING ADVERSE EVENTS, NEAR MISSES, AND UNSAFE CONDITIONS FOR HEALTHCARE TRAINEES (U.S. CLS. 21, 23, 26, 36 AND 38).

MARK SPARACINO, EXAMINING ATTORNEY

SN 85-140,936. NOVELLUS HEALTHCARE COMMUNICATIONS, LLC, MONROE TOWNSHIP, NJ. FILED 9-29-2010.



NO CLAIM IS MADE TO THE EXCLUSIVE RIGHT TO USE "PEDIATRIC NP/PA THE OFFICIAL NEWSPAPER FOR THE PEDIATRIC/ADOLESCENT NURSE AND ADVANCED PRACTITIONER", APART FROM THE MARK AS SHOWN.

THE MARK CONSISTS OF THE WORDS "PEDIATRIC NP/PA" WHERE THERE IS A CHILDREN'S CRAYON-LIKE DRAWING OF A SUN BETWEEN THE WORDS "PEDIATRIC" AND "NP/PA". SUPERIMPOSED IN FRONT OF THE SUN IS AN IMPRESSIONISTIC RENDERING OF A BOY AND A GIRL WITH THEIR ARMS UP IN THE AIR. THERE IS A STRAIGHT HORIZONTAL LINE UNDERSCORING THE PHRASE "PEDIATRIC NP/PA". UNDERNEATH THE HORIZONTAL LINE IS THE TAG-LINE, ON TWO SEPARATE LINES "THE OFFICIAL NEWSPAPER FOR THE PEDIATRIC/ADOLESCENT NURSE AND ADVANCED PRACTITIONER".

FOR PROVIDING DOWNLOADABLE ELECTRONIC NEWSPAPERS AND NEWSLETTERS IN THE FIELDS OF PEDIATRICS AND NURSING (U.S. CLS. 21, 23, 26, 36 AND 38).
DANNEAN HETZEL, EXAMINING ATTORNEY

CLASS 9—(Continued).

SN 85-140,975. ENCORE SOFTWARE, INC., LOS ANGELES, CA. FILED 9-29-2010.

ELEMENTARY ADVANTAGE

THE MARK CONSISTS OF STANDARD CHARACTERS WITHOUT CLAIM TO ANY PARTICULAR FONT, STYLE, SIZE, OR COLOR.

OWNER OF U.S. REG. NOS. 2,387,498, 2,487,188 AND OTHERS.

NO CLAIM IS MADE TO THE EXCLUSIVE RIGHT TO USE "ELEMENTARY", APART FROM THE MARK AS SHOWN.

FOR CHILDREN'S EDUCATIONAL SOFTWARE (U.S. CLS. 21, 23, 26, 36 AND 38).

FIRST USE 9-1-1996; IN COMMERCE 9-1-1996.
ANDREW LEASER, EXAMINING ATTORNEY

SN 85-141,919. ATTORNEYS' TITLE INSURANCE FUND, ORLANDO, FL. FILED 9-30-2010.

THE FUND

THE MARK CONSISTS OF STANDARD CHARACTERS WITHOUT CLAIM TO ANY PARTICULAR FONT, STYLE, SIZE, OR COLOR.

OWNER OF U.S. REG. NO. 1,613,190.

FOR SOFTWARE FOR USE IN THE MANAGEMENT AND PROVISION OF TITLE INSURANCE UNDERWRITING SERVICES, REAL ESTATE TRANSACTION SERVICES, REAL ESTATE CLOSING SERVICES, AND REAL ESTATE LAW SERVICES (U.S. CLS. 21, 23, 26, 36 AND 38).

MICHAEL ENGEL, EXAMINING ATTORNEY

SN 85-142,012. 3 M E LTD, AKA 3 M E, LONDON, UNITED KINGDOM, FILED 9-30-2010.

Access All Areas

THE MARK CONSISTS OF STANDARD CHARACTERS WITHOUT CLAIM TO ANY PARTICULAR FONT, STYLE, SIZE, OR COLOR.

FOR COMPUTER APPLICATION SOFTWARE FOR MOBILE PHONES, NAMELY, SOFTWARE FOR SOCIAL GAMING AND NETWORKING; COMPUTER APPLICATION SOFTWARE FOR SMARTPHONE APPLICATIONS, NAMELY, SOFTWARE FOR SOCIAL GAMING AND NETWORKING; COMPUTER GAME PROGRAMS; COMPUTER GAME SOFTWARE (U.S. CLS. 21, 23, 26, 36 AND 38).

TRACY FLETCHER, EXAMINING ATTORNEY

CLASS 9—(Continued).

SN 85-142,173. ASSA ABLOY AB, STOCKHOLM, SWEDEN, FILED 9-30-2010.

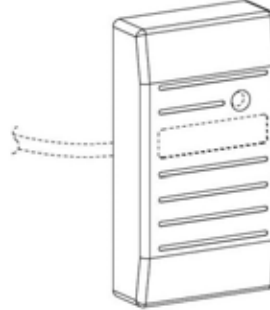

THE MARK CONSISTS OF A THREE DIMENSIONAL CONFIGURATION OF AN RFID READER COMPRISING A RECTANGULAR HOUSING WITH A FRONT FACE, TWO SIDE FACES AND TOP AND BOTTOM. THE FRONT FACE INCLUDES A TOP ANGLED SURFACE AND A BOTTOM ANGLED SURFACE WITH THE SIDE FACES TAPERED AT THE TOP AND BOTTOM AT THE ANGLED PORTIONS OF THE FRONT FACE. ALL FORWARD FACING EDGES THAT TRANSITION BETWEEN SURFACES ARE ROUNDED. SIX HORIZONTAL GROOVES ARE FORMED WITHIN THE FRONT FACE WITH THE SECOND GROOVE FROM THE TOP BEING SHORTER AND A CIRCLE PLACED TO THE RIGHT OF THE SHORTER GROOVE. A GAP IS SET BETWEEN THE BOTTOM FOUR LINES AND THE TOP TWO LINES. THE MATTER SHOWN IN BROKEN OR DOTTED LINES IS NOT PART OF THE MARK AND SERVES ONLY TO SHOW THE POSITION OR PLACEMENT OF THE MARK.

SEC. 2(F).

FOR RADIO FREQUENCY IDENTIFICATION (RFID) READERS (U.S. CLS. 21, 23, 26, 36 AND 38).

FIRST USE 5-27-1999; IN COMMERCE 5-27-1999.
ADA HAN, EXAMINING ATTORNEY

SN 85-142,175. ASSA ABLOY AB, STOCKHOLM, SWEDEN, FILED 9-30-2010.

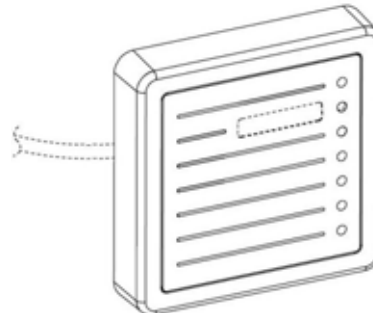

THE MARK CONSISTS OF THE MARK CONSISTS OF A THREE DIMENSIONAL CONFIGURATION OF AN RFID READER COMPRISING A HOUSING HAVING A GENERALLY QUADRANGULAR FRONT FACE AND A PLURALITY OF SIDE SURFACES CONNECTED TO THE FRONT FACE. THE FRONT FACE DEFINES A ROUNDED PERIPHERAL EDGE WHICH TRANSITIONS INTO THE PLURALITY OF SIDE SURFACES, AND FURTHER INCLUDES A GENERALLY QUADRANGULAR GROOVE. THE FRONT FACE ADDITIONALLY INCLUDES SIX LONG GROOVES

CLASS 9—(Continued).

IN VERTICAL ALIGNMENT WITH EACH OTHER AND A SHORT GROOVE DISPOSED BELOW THE UPPERMOST LONG GROOVE. THE FRONT FACE FURTHER INCLUDES A GENERALLY QUADRANGULAR RECESS AND AN INDICATOR LIGHT DISPOSED ALONG A COMMON HORIZONTAL AXIS WITH THE SHORT GROOVE. SIX ROUNDED DEPRESSIONS ARE FORMED WITHIN THE FRONT FACE AND ARE ALIGNED ALONG A COMMON VERTICAL AXIS WITH THE INDICATOR LIGHT AND ARE HORIZONTALLY ALIGNED WITH RESPECTIVE ONES OF THE LONG GROOVES. THE MATTER SHOWN IN BROKEN OR DOTTED LINES IS NOT PART OF THE MARK AND SERVES ONLY TO SHOW THE POSITION OR PLACEMENT OF THE MARK.

SEC. 2(F).
 FOR RADIO FREQUENCY IDENTIFICATION (RFID) READERS (U.S. CLS. 21, 23, 26, 36 AND 38).
 FIRST USE 11-13-1992; IN COMMERCE 5-6-1993.
 ADA HAN, EXAMINING ATTORNEY

SN 85-142,178. ASSA ABLOY AB, STOCKHOLM, SWEDEN, FILED 9-30-2010.

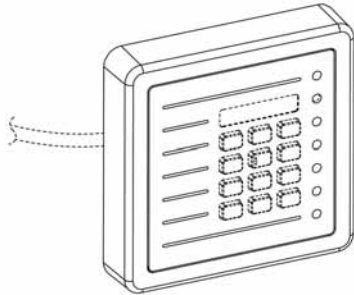

THE MARK CONSISTS OF A THREE DIMENSIONAL CONFIGURATION OF AN RFID READER COMPRISING A HOUSING HAVING A GENERALLY QUADRANGULAR FRONT FACE AND A PLURALITY OF SIDE SURFACES CONNECTED TO THE FRONT FACE. THE FRONT FACE DEFINES A ROUNDED PERIPHERAL EDGE WHICH TRANSITIONS INTO THE PLURALITY OF SIDE SURFACES, AND FURTHER INCLUDES A GENERALLY QUADRANGULAR GROOVE. THE FRONT FACE ADDITIONALLY INCLUDES FIVE SHORT GROOVES IN VERTICAL ALIGNMENT WITH EACH OTHER, A GENERALLY QUADRANGULAR RECESS AND AN INDICATOR LIGHT DISPOSED ALONG A COMMON HORIZONTAL AXIS WITH THE UPPERMOST SHORT GROOVE. A PAIR OF LONG GROOVES ARE DISPOSED ON OPPOSING ENDS OF THE SHORT GROOVES. SIX ROUNDED DEPRESSIONS ARE FORMED WITHIN THE FRONT FACE AND ARE ALIGNED ALONG A COMMON VERTICAL AXIS WITH THE INDICATOR LIGHT AND ARE HORIZONTALLY ALIGNED WITH RESPECTIVE ONES OF THE SHORT AND LONG GROOVES. THE FRONT FACE ADDITIONALLY INCLUDES AN OFFSET KEYPAD SHOWN IN DOTTED LINES. THE MATTER SHOWN IN BROKEN OR DOTTED LINES IS NOT PART OF THE MARK AND SERVES ONLY TO SHOW THE POSITION OR PLACEMENT OF THE MARK.

SEC. 2(F).
 FOR RADIO FREQUENCY IDENTIFICATION (RFID) READERS (U.S. CLS. 21, 23, 26, 36 AND 38).
 FIRST USE 7-14-1999; IN COMMERCE 1-1-2000.
 ADA HAN, EXAMINING ATTORNEY

CLASS 9—(Continued).

SN 85-142,181. ASSA ABLOY AB, STOCKHOLM, SWEDEN, FILED 9-30-2010.

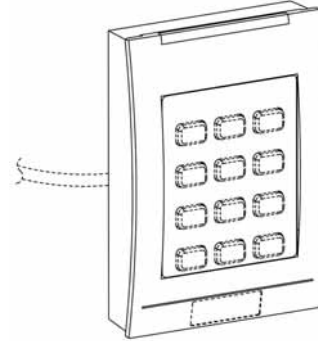

THE MARK CONSISTS OF A THREE DIMENSIONAL CONFIGURATION OF AN RFID READER COMPRISING A HOUSING DEFINING AN ARCUATE, SLIGHTLY CONVEX FRONT FACE WITH A GENERALLY QUADRANGULAR PERIPHERAL EDGE, THE ENTIRE LENGTH OF WHICH OVERHANGS CORRESPONDING SIDE SURFACE SEGMENTS OF THE HOUSING. THE HOUSING FURTHER INCLUDES A CUTOUT FORMED WITHIN THE CONVEX FRONT FACE TO DEFINE A PLANAR SURFACE HAVING A KEYPAD SHOWN IN DOTTED LINES. THE HOUSING ADDITIONALLY INCLUDES AN ELONGATE LIGHT BAR WHICH IS SUBSTANTIALLY FLUSH WITH THE FRONT FACE AND EXTENDS ALONG ONE OF THE LATERALLY EXTENDING SEGMENTS OF THE PERIPHERAL EDGE OF THE FRONT FACE. THE HOUSING FURTHER INCLUDES A HORIZONTAL GROOVE FORMED BELOW THE CUT-OUT. THE MATTER SHOWN IN BROKEN OR DOTTED LINES IS NOT PART OF THE MARK AND SERVES ONLY TO SHOW THE POSITION OR PLACEMENT OF THE MARK.

SEC. 2(F).
 FOR RADIO FREQUENCY IDENTIFICATION (RFID) READERS (U.S. CLS. 21, 23, 26, 36 AND 38).
 FIRST USE 4-15-2003; IN COMMERCE 7-1-2003.
 ADA HAN, EXAMINING ATTORNEY

SN 85-142,184. ASSA ABLOY AB, STOCKHOLM, SWEDEN, FILED 9-30-2010.

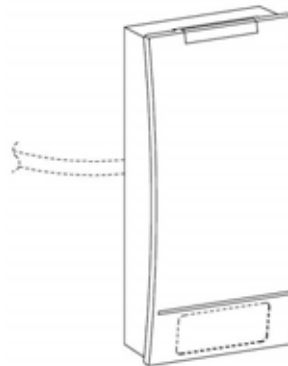

THE MARK CONSISTS OF A THREE DIMENSIONAL CONFIGURATION OF AN RFID READER COMPRISING A HOUSING DEFINING AN ARCUATE, SLIGHTLY CONVEX FRONT FACE WITH A GENERALLY QUADRANGULAR PERIPHERAL EDGE, THE ENTIRE LENGTH OF WHICH

CLASS 9—(Continued).

OVERHANGS CORRESPONDING SIDE SURFACE SEGMENTS OF THE HOUSING. THE HOUSING FURTHER INCLUDES AN ELONGATE LIGHT BAR WHICH IS SUBSTANTIALLY FLUSH WITH THE FRONT FACE AND EXTENDS ALONG ONE OF THE LATERALLY EXTENDING SEGMENTS OF TOP PERIPHERAL EDGE OF THE FRONT FACE. THE MATTER SHOWN IN BROKEN OR DOTTED LINES IS NOT PART OF THE MARK AND SERVES ONLY TO SHOW THE POSITION OR PLACEMENT OF THE MARK.

SEC. 2(F).
FOR RADIO FREQUENCY IDENTIFICATION (RFID) READERS (U.S. CLS. 21, 23, 26, 36 AND 38).
FIRST USE 8-7-2002; IN COMMERCE 8-7-2002.
ADA HAN, EXAMINING ATTORNEY



SN 85-142,188. ASSA ABLOY AB, STOCKHOLM, SWEDEN, FILED 9-30-2010.

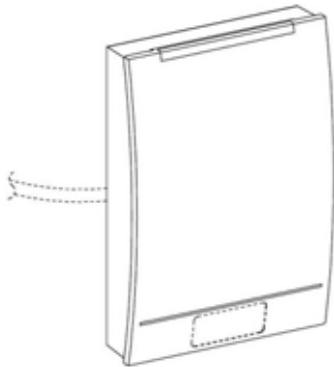

THE MARK CONSISTS OF THE MARK CONSISTS OF A THREE DIMENSIONAL CONFIGURATION OF AN RFID READER COMPRISING A HOUSING DEFINING AN ARCULATE, SLIGHTLY CONVEX FRONT FACE WITH A GENERALLY QUADRANGULAR PERIPHERAL EDGE, THE ENTIRE LENGTH OF WHICH OVERHANGS CORRESPONDING SIDE SURFACE SEGMENTS OF THE HOUSING, THE HOUSING FURTHER INCLUDING AN ELONGATE LIGHT BAR WHICH IS SUBSTANTIALLY FLUSH WITH THE FRONT FACE AND EXTENDS ALONG ONE OF THE LATERALLY EXTENDING SEGMENTS OF THE TOP PERIPHERAL EDGE OF THE FRONT FACE. THE MATTER SHOWN IN BROKEN OR DOTTED LINES IS NOT PART OF THE MARK AND SERVES ONLY TO SHOW THE POSITION OR PLACEMENT OF THE MARK.

SEC. 2(F).
FOR RADIO FREQUENCY IDENTIFICATION (RFID) READERS (U.S. CLS. 21, 23, 26, 36 AND 38).
FIRST USE 8-7-2002; IN COMMERCE 8-7-2002.
ADA HAN, EXAMINING ATTORNEY

CLASS 9—(Continued).

SN 85-142,192. ASSA ABLOY AB, STOCKHOLM, SWEDEN, FILED 9-30-2010.

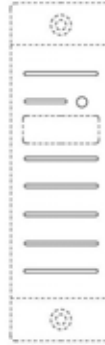

THE MARK CONSISTS OF SEVEN HORIZONTAL LINES AND A CIRCLE, WHERE THE LINE SECOND FROM THE TOP IS SHORTER THAN THE REMAINING LINES, AND HAS A CIRCLE TO THE RIGHT. THE DOTTED LINES ARE NOT PART OF THE MARK AND SERVE ONLY TO SHOW THE PLACEMENT OF THE MARK UPON THE FRONT OF THE PRODUCT.

SEC. 2(F).
FOR RADIO FREQUENCY IDENTIFICATION (RFID) READERS (U.S. CLS. 21, 23, 26, 36 AND 38).
FIRST USE 7-1-1992; IN COMMERCE 7-1-1992.
ADA HAN, EXAMINING ATTORNEY



SN 85-144,239. DE' LONGHI APPLIANCES S.R.L., TREVISO, ITALY, FILED 10-4-2010.



OWNER OF U.S. REG. NOS. 1,200,965, 1,597,173 AND OTHERS.

THE MARK CONSISTS OF THE WORD "DELONGHI" IN A STYLIZED FONT WITHIN CONCENTRIC OVALS.

FOR ELECTRIC HOUSEHOLD IRONING APPARATUS COMPRISING ELECTRIC AND STEAM IRONS, ELECTRIC FLAT IRONS, ELECTRIC PRESS IRON AND A STEAM GENERATING DEVICE, ALL SOLD AS A UNIT; ELECTRIC IRONING PRESSING MACHINES; STEAM IRONING PRESSING MACHINES; PROTECTIVE COVERS FOR ELECTRIC AND STEAM IRONS; PROTECTIVE SOLEPLATE FOR FLAT STEAM IRON AND STRUCTURAL PARTS AND ACCESSORIES OF THE ABOVE GOODS, NAMELY, IRON COVERS (U.S. CLS. 21, 23, 26, 36 AND 38).

TINA MAI, EXAMINING ATTORNEY

CLASS 9—(Continued).

SN 85-144,267. TIBURON, INC., PLEASANTON, CA. FILED 10-4-2010.

dispatchNow

THE MARK CONSISTS OF STANDARD CHARACTERS WITHOUT CLAIM TO ANY PARTICULAR FONT, STYLE, SIZE, OR COLOR.

OWNER OF U.S. REG. NO. 1,753,660.

FOR COMPUTER SOFTWARE FOR AUTOMATING THE DISPATCH FUNCTIONS OF GOVERNMENT AGENCIES, NAMELY, CITY/COUNTY/STATE/FEDERAL POLICE, FIRE AND EMERGENCY MEDICAL SERVICES; COMPUTER SOFTWARE FOR MAINTAINING, UPDATING AND UTILIZING PUBLIC SECTOR DATA REQUIRED FOR USE BY GOVERNMENT AGENCIES, NAMELY, CITY/COUNTY/STATE/FEDERAL PUBLIC SAFETY AGENCIES (U.S. CLS. 21, 23, 26, 36 AND 38).

DARRYL SPRUILL, EXAMINING ATTORNEY

SN 85-144,705. LULU SOFTWARE, LLC, ST. MICHAELS, BARBADOS, FILED 10-4-2010.

SODA 3D PDF READER

THE MARK CONSISTS OF STANDARD CHARACTERS WITHOUT CLAIM TO ANY PARTICULAR FONT, STYLE, SIZE, OR COLOR.

OWNER OF U.S. REG. NO. 3,881,540.

NO CLAIM IS MADE TO THE EXCLUSIVE RIGHT TO USE "3D PDF READER", APART FROM THE MARK AS SHOWN.

FOR COMPUTER PROGRAMMES FOR DOCUMENT MANAGEMENT; COMPUTER SOFTWARE FOR MANIPULATING AND CONVERTING DIGITAL IMAGES THAT MAY BE DOWNLOADED FROM A GLOBAL COMPUTER NETWORK (U.S. CLS. 21, 23, 26, 36 AND 38).

INGRID C. EULIN, EXAMINING ATTORNEY

SN 85-145,724. ROBERT CHRIS CONSULTING INC., BOCA RATON, FL. FILED 10-5-2010.

Dirty Diablos

THE MARK CONSISTS OF STANDARD CHARACTERS WITHOUT CLAIM TO ANY PARTICULAR FONT, STYLE, SIZE, OR COLOR.

THE ENGLISH TRANSLATION OF "DIABLOS" IN THE MARK IS "DEVILS".

FOR DOWNLOADABLE FILMS AND MOVIES FEATURING ADULT CONTENT PROVIDED VIA A VIDEO-ON-DEMAND SERVICE (U.S. CLS. 21, 23, 26, 36 AND 38).

FIRST USE 4-1-2008; IN COMMERCE 9-25-2009.

KELLY TRUSILO, EXAMINING ATTORNEY

CLASS 9—(Continued).

SN 85-146,135. ATTORNEYS' TITLE INSURANCE FUND, ORLANDO, FL. FILED 10-6-2010.



OWNER OF U.S. REG. NOS. 2,512,216 AND 3,690,277.

THE MARK CONSISTS OF TWO OVERLAPPING HORIZONTAL ARCS ABOVE THE TERM "ATIDS XE".

FOR SOFTWARE FOR USE IN REAL ESTATE TITLE SEARCHING AND REAL ESTATE CLOSING SERVICES (U.S. CLS. 21, 23, 26, 36 AND 38).

FIRST USE 1-20-2009; IN COMMERCE 1-20-2009.

MICHAEL ENGEL, EXAMINING ATTORNEY

SN 85-146,180. ATTORNEYS' TITLE INSURANCE FUND, ORLANDO, FL. FILED 10-6-2010.



OWNER OF U.S. REG. NOS. 2,512,216 AND 3,690,277.

THE COLOR(S) BLUE, BLACK AND GRAY IS/ARE CLAIMED AS A FEATURE OF THE MARK.

THE MARK CONSISTS OF TWO OVERLAPPING HORIZONTAL ARCS IN THE COLORS BLUE AND BLACK ABOVE THE TERMS "ATIDS" IN BLUE AND "XE" IN GRAY, ABOVE THE WORDS "THE NEXT GENERATION" IN GRAY.

FOR SOFTWARE FOR USE IN REAL ESTATE TITLE SEARCHING AND REAL ESTATE CLOSING SERVICES (U.S. CLS. 21, 23, 26, 36 AND 38).

FIRST USE 1-20-2009; IN COMMERCE 1-20-2009.

MICHAEL ENGEL, EXAMINING ATTORNEY

SN 85-146,226. ARISTOCRAT TECHNOLOGIES AUSTRALIA PTY LTD., NORTH RYDE, NSW, AUSTRALIA, FILED 10-6-2010.

MAX BET BOOSTER

THE MARK CONSISTS OF STANDARD CHARACTERS WITHOUT CLAIM TO ANY PARTICULAR FONT, STYLE, SIZE, OR COLOR.

PRIORITY CLAIMED UNDER SEC. 44(D) ON AUSTRALIA APPLICATION NO. 1378624, FILED 8-27-2010, REG. NO. 1378624, DATED 8-27-2010, EXPIRES 8-27-2020.

NO CLAIM IS MADE TO THE EXCLUSIVE RIGHT TO USE "BET", APART FROM THE MARK AS SHOWN.

FOR ELECTRONIC GAMING MACHINES, NAMELY, DEVICES WHICH ACCEPT A WAGER (U.S. CLS. 21, 23, 26, 36 AND 38).

RAMONA ORTIGA, EXAMINING ATTORNEY

CLASS 9—(Continued).

SN 85-146,273. ARISTOCRAT TECHNOLOGIES AUSTRALIA PTY LTD., NORTH RYDE, NSW, AUSTRALIA, FILED 10-6-2010.

CRAZY CASH

THE MARK CONSISTS OF STANDARD CHARACTERS WITHOUT CLAIM TO ANY PARTICULAR FONT, STYLE, SIZE, OR COLOR.

PRIORITY CLAIMED UNDER SEC. 44(D) ON AUSTRALIA APPLICATION NO. 1382137, FILED 9-13-2010, REG. NO. 1382137, DATED 9-13-2010, EXPIRES 9-13-2020.

NO CLAIM IS MADE TO THE EXCLUSIVE RIGHT TO USE "CASH", APART FROM THE MARK AS SHOWN.

FOR ELECTRONIC GAMING MACHINES, NAMELY, DEVICES WHICH ACCEPT A WAGER (U.S. CLS. 21, 23, 26, 36 AND 38).

RAMONA ORTIGA, EXAMINING ATTORNEY

CLASS 9—(Continued).

SN 85-147,704. TURNER ENTERTAINMENT CO., BURBANK, CA. FILED 10-7-2010.

Ruby Slippers

THE MARK CONSISTS OF STANDARD CHARACTERS WITHOUT CLAIM TO ANY PARTICULAR FONT, STYLE, SIZE, OR COLOR.

OWNER OF U.S. REG. NOS. 2,647,264, 2,949,422 AND OTHERS.

FOR GAMING DEVICES, NAMELY, GAMING MACHINES, SLOT MACHINES, WITH OR WITHOUT VIDEO OUTPUT; GAMING MACHINES INCLUDING SLOT MACHINES OR VIDEO LOTTERY TERMINALS (U.S. CLS. 21, 23, 26, 36 AND 38).

FIRST USE 4-2-2008; IN COMMERCE 4-2-2008.

SETH A. RAPPAPORT, EXAMINING ATTORNEY

SN 85-146,385. VISONIC LTD., TEL AVIV, ISRAEL, FILED 10-6-2010.

RealAlarm

THE MARK CONSISTS OF STANDARD CHARACTERS WITHOUT CLAIM TO ANY PARTICULAR FONT, STYLE, SIZE, OR COLOR.

FOR ALARMS AND ALARM INSTALLATIONS; ALARM MONITORING SYSTEMS; ALARM AND SECURITY SYSTEMS COMPRISING COMPUTER SOFTWARE AND COMPUTER HARDWARE, AND ELECTRONIC SENSORS, ALL FOR DETECTING, RECORDING, AND SIGNALING INTRUSION, MOTION, SMOKE, GAS, FIRE, HEAT AND TEMPERATURE CHANGE, FLOOD, POWER FAILURE, MECHANICAL FAILURE, GLASS BREAKAGE, ALARM STATUS AND DATA PERTAINING THERETO, AND FOR DISPLAYING, RECORDING AND TRANSMITTING ACOUSTICAL AND VIDEO SIGNALS TO A CONTROL PANEL AND TO REMOTE MONITORING CENTERS VIA COMMUNICATION NETWORKS, INTERNET, CELLULAR, AND BY EMAIL, AND TO MOBILE TELEPHONES AND FOR VERIFICATION OF ALARM EVENTS; TWO WAY ELECTRONIC DISPLAY INTERFACES COMPRISING GRAPHICAL USER INTERFACE SOFTWARE WHICH CAN TRANSMIT, ANALYZE AND COMPARE INFORMATION OBTAINED BY SECURITY SYSTEMS, VERIFY ALARM EVENTS AND RECEIVE INSTRUCTIONS AS TO THE SIGNALLED EVENT (U.S. CLS. 21, 23, 26, 36 AND 38).

COLLEEN KEARNEY, EXAMINING ATTORNEY

SN 85-147,819. IDEO PLASTICS INC., CHILLIWACK, BC, CANADA, FILED 10-7-2010.



NO CLAIM IS MADE TO THE EXCLUSIVE RIGHT TO USE "SKINS", APART FROM THE MARK AS SHOWN.

THE MARK CONSISTS OF AN UMBRELLA ABOVE THE STYLIZED WORDS "DRY SKINZ".

FOR PROTECTIVE CARRYING CASES FOR PORTABLE MUSIC PLAYERS, NAMELY, MP3 PLAYERS; PROTECTIVE CARRYING CASES SPECIALLY ADAPTED FOR GLOBAL POSITIONING SYSTEM (GPS) APPARATUS; PROTECTIVE CARRYING CASES SPECIALLY ADAPTED FOR PERSONAL DIGITAL ASSISTANTS (PDA); PROTECTIVE CARRYING CASES SPECIALLY ADAPTED FOR VIDEO GAME CONSOLES FOR USE WITH AN EXTERNAL DISPLAY SCREEN OR MONITOR; PROTECTIVE COVERS AND CASES FOR CELL PHONES, LAPTOPS AND PORTABLE MEDIA PLAYERS (U.S. CLS. 21, 23, 26, 36 AND 38).

MARY CRAWFORD, EXAMINING ATTORNEY

CLASS 9—(Continued).

SN 85-152,383. SYSTEMS AND ELECTRONIC DEVELOPMENT FZCO, DUBAI, UNITED ARAB EMIR., FILED 10-14-2010.

Magna

THE MARK CONSISTS OF "MAGNA" WORD WRITTEN IN ENGLISH LETTERS ITALIC.

FOR DOT MATRIX PRINTERS; IMPACT PRINTERS; PRINTERS; PRINTERS FOR COMPUTERS; PRINTERS FOR USE WITH COMPUTERS (U.S. CLS. 21, 23, 26, 36 AND 38).

FIRST USE 1-1-1998; IN COMMERCE 1-1-1998.

DAVID TAYLOR, EXAMINING ATTORNEY

SN 85-153,610. UICO, INC., GLENDALE HEIGHTS, IL. FILED 10-15-2010.

SMARTSURAFACE

THE MARK CONSISTS OF STANDARD CHARACTERS WITHOUT CLAIM TO ANY PARTICULAR FONT, STYLE, SIZE, OR COLOR.

FOR TOUCH PADS; COMPUTER TOUCH SCREENS; ELECTRONIC AND ELECTRICAL CONTROLLERS FOR USE WITH TOUCH PADS AND TOUCH SCREENS; TOUCH SENSITIVE INPUT DEVICES, NAMELY, ELECTRIC CONTROL PANELS FOR INDUSTRIAL GOODS, DURABLE GOODS, AND APPLIANCES, THAT ALLOW THE USER TO INTERFACE WITH OR CONTROL THE PRODUCTS, AND OPERATING SOFTWARE THEREFOR; RESISTIVE, SURFACE, OR PROJECTED CAPACITIVE TOUCH SENSING PRODUCTS THAT ARE USED FOR SWITCHING AND CONTROLLING INDUSTRIAL, APPLIANCE AND DURABLE GOODS, NAMELY, ELECTRIC TOUCH SENSOR CONTROL PANELS AND COMPONENTS IN THE NATURE OF RESISTIVE, SURFACE, OR PROJECTED CAPACITIVE SENSOR INTEGRATED CIRCUITS, ELECTRONIC INTEGRATED CIRCUIT CHIPS, TOUCH SENSOR INTEGRATED CIRCUITS, TOUCH BUTTON INTEGRATED CIRCUIT CHIPS, TOUCH SCREEN INTEGRATED CIRCUIT ELEMENTS, NAMELY, TOUCH SCREEN CONDUCTIVE FILMS; AND COMPUTER SOFTWARE TO PROVIDE AND ENHANCE THE FUNCTIONALITY OF THE TOUCH SENSOR CONTROLS AND COMPONENTS, FOR USE BY OTHER MANUFACTURERS (U.S. CLS. 21, 23, 26, 36 AND 38).

DAVID HOFFMAN, EXAMINING ATTORNEY

SN 85-154,145. ALIPHCOM, SAN FRANCISCO, CA. FILED 10-15-2010.

THE NERD

THE MARK CONSISTS OF STANDARD CHARACTERS WITHOUT CLAIM TO ANY PARTICULAR FONT, STYLE, SIZE, OR COLOR.

FOR WIRELESS COMMUNICATION DEVICES FOR VOICE, DATA, OR IMAGE TRANSMISSION (U.S. CLS. 21, 23, 26, 36 AND 38).

JOHN KELLY, EXAMINING ATTORNEY

CLASS 9—(Continued).

SN 85-154,838. ATTORNEYS' TITLE INSURANCE FUND, ORLANDO, FL. FILED 10-18-2010.

THE FUND CONCEPT

THE MARK CONSISTS OF STANDARD CHARACTERS WITHOUT CLAIM TO ANY PARTICULAR FONT, STYLE, SIZE, OR COLOR.

OWNER OF U.S. REG. NO. 1,613,190.

FOR ONLINE, DOWNLOADABLE NEWSLETTERS IN THE FIELDS OF TITLE INSURANCE UNDERWRITING SERVICES, REAL ESTATE TRANSACTION SERVICES, REAL ESTATE CLOSING SERVICES, AND REAL ESTATE LAW SERVICES (U.S. CLS. 21, 23, 26, 36 AND 38).

FIRST USE 0-0-2003; IN COMMERCE 0-0-2003.

BARBARA GAYNOR, EXAMINING ATTORNEY

SN 85-154,886. ATTORNEYS' TITLE INSURANCE FUND, ORLANDO, FL. FILED 10-18-2010.

ATIDS

THE MARK CONSISTS OF STANDARD CHARACTERS WITHOUT CLAIM TO ANY PARTICULAR FONT, STYLE, SIZE, OR COLOR.

OWNER OF U.S. REG. NOS. 2,512,216 AND 3,690,277.

FOR SOFTWARE FOR USE IN REAL ESTATE TITLE SEARCHING (U.S. CLS. 21, 23, 26, 36 AND 38).

FIRST USE 11-0-1976; IN COMMERCE 0-0-1998.

BARBARA GAYNOR, EXAMINING ATTORNEY

SN 85-154,908. ATTORNEYS' TITLE INSURANCE FUND, ORLANDO, FL. FILED 10-18-2010.

ATIDS XE

THE MARK CONSISTS OF STANDARD CHARACTERS WITHOUT CLAIM TO ANY PARTICULAR FONT, STYLE, SIZE, OR COLOR.

OWNER OF U.S. REG. NOS. 2,512,216 AND 3,690,277.

FOR SOFTWARE FOR USE IN REAL ESTATE TITLE SEARCHING (U.S. CLS. 21, 23, 26, 36 AND 38).

FIRST USE 1-20-2009; IN COMMERCE 1-20-2009.

BARBARA GAYNOR, EXAMINING ATTORNEY

CLASS 9—(Continued).

SN 85-158,609. ARKWHAT LLC, OAKLAND, CA. FILED 10-21-2010.



THE MARK CONSISTS OF HIPPO IMAGE ABOVE LETTERS "ARK".
 FOR CASES FOR MOBILE PHONES (U.S. CLS. 21, 23, 26, 36 AND 38).
 FIRST USE 10-10-2010; IN COMMERCE 10-10-2010.
 CAROLINE WOOD, EXAMINING ATTORNEY

CLASS 9—(Continued).

SN 85-160,783. AINSWORTH GAME TECHNOLOGY, NEW-INGTON, AUSTRALIA, FILED 10-25-2010.



NO CLAIM IS MADE TO THE EXCLUSIVE RIGHT TO USE "JACKPOTS", APART FROM THE MARK AS SHOWN. THE COLOR(S) RED, BLACK, YELLOW, WHITE, BLUE AND PURPLE IS/ARE CLAIMED AS A FEATURE OF THE MARK.
 THE MARK CONSISTS OF THE WORDING "WORLD OF JACKPOTS" ACROSS A GLOBE OF THE WORLD WHICH RADIATES; THE WORDING "WORLD OF JACKPOTS" IS IN RED AND PARTIALLY OUTLINE IN YELLOW AND BLACK; THE WORDING "WORLD OF JACKPOTS" IS SHADOWED BY THE FINE YELLOW AND BLACK OUTLINE; THE SPACE BETWEEN THIS OUTLINE AND THE WORDS "WORLD OF JACKPOTS" IS IN WHITE; THE GLOBE OF THE WORLD IS IN BLUE WITH THE CONTINENTS APPEARING IN WHITE; THE LATITUDE AND LONGITUDINAL LINES OF THE GLOBE APPEAR IN FINE WHITE LINES; THE GLOBE IS SURROUNDED BY A RADIATING LAYER IN WHICH THE RAYS APPEAR IN ALTERNATING COLORS OF RED, PURPLE AND BLUE.
 FOR COMPUTER SOFTWARE AND FIRMWARE FOR GAMES OF CHANCE ON ANY COMPUTERIZED PLATFORM, INCLUDING DEDICATED GAMING CONSOLES, VIDEO BASED SLOT MACHINES, REEL BASED SLOT MACHINES, AND VIDEO LOTTERY TERMINALS (U.S. CLS. 21, 23, 26, 36 AND 38).
 BILL DAWE, EXAMINING ATTORNEY

SN 85-159,432. MOZART NETWORKS, LLC, NEW YORK, NY. FILED 10-22-2010.

My Mozart

THE MARK CONSISTS OF STANDARD CHARACTERS WITHOUT CLAIM TO ANY PARTICULAR FONT, STYLE, SIZE, OR COLOR.
 NO CLAIM IS MADE TO THE EXCLUSIVE RIGHT TO USE "MOZART", APART FROM THE MARK AS SHOWN.
 FOR AUDIO AND VIDEO RECORDINGS FEATURING MUSIC AND ARTISTIC PERFORMANCES (U.S. CLS. 21, 23, 26, 36 AND 38).
 KATHERINE CHANG, EXAMINING ATTORNEY

CLASS 9—(Continued).

SN 85-161,586. EASY INTERACTIVE, INC., AUSTIN, TX. FILED 10-26-2010.

CLASS 9—(Continued).

SN 85-161,835. COINSTAR, INC., BELLEVUE, WA. FILED 10-26-2010.

EASY INTERACTIVE

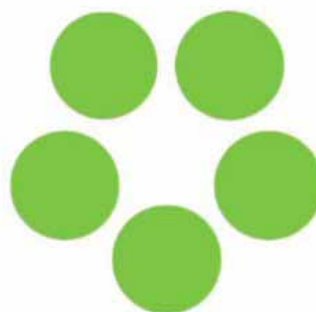

THE MARK CONSISTS OF STANDARD CHARACTERS WITHOUT CLAIM TO ANY PARTICULAR FONT, STYLE, SIZE, OR COLOR.

NO CLAIM IS MADE TO THE EXCLUSIVE RIGHT TO USE "INTERACTIVE", APART FROM THE MARK AS SHOWN.

FOR COMPUTER GAME SOFTWARE FOR USE ON COMPUTERS, CONSOLES, AND PORTABLE ELECTRONIC DEVICES; COMPUTER GAME PROGRAMS; COMPUTER GAME SOFTWARE; COMPUTER GAME EQUIPMENT CONTAINING MEMORY DEVICES NAMELY, DISKS AND CARTRIDGES; COMPUTER PERIPHERALS AND COMPUTER SOFTWARE FOR COMPUTER, VIDEO AND ELECTRONIC GAMES; ACTION-SKILL COMPUTER, VIDEO AND ELECTRONIC GAMES, NAMELY, INTERACTIVE VIDEO GAMES OF VIRTUAL REALITY COMPRISED OF COMPUTER HARDWARE AND SOFTWARE FOR USE WITH AN EXTERNAL MONITOR; ACTION-SKILL COMPUTER, VIDEO AND ELECTRONIC GAMES, NAMELY, INTERACTIVE MULTIMEDIA COMPUTER GAME PROGRAMS; ACTION-SKILL GAMES, NAMELY, COMPUTER VIDEO AND ELECTRONIC GAME CARTRIDGES; GAME CARTRIDGES, DISKS AND COMPACT DISKS FOR USE IN COMPUTER, VIDEO AND ELECTRONIC GAMES; CD-ROM VIDEO GAME SOFTWARE; DVD-ROM VIDEO GAME SOFTWARE; CD-ROM COMPUTER GAME SOFTWARE; DVD-ROM COMPUTER GAME SOFTWARE (U.S. CLS. 21, 23, 26, 36 AND 38).

MICHAEL WEBSTER, EXAMINING ATTORNEY

THE COLOR(S) GREEN IS/ARE CLAIMED AS A FEATURE OF THE MARK.

THE MARK CONSISTS OF FIVE GREEN DOTS ARRANGED IN THE SHAPE OF A PENTAGON.

FOR SELF-SERVICE MACHINES CONTAINING ELECTRONIC EQUIPMENT WHICH CONVERT COINS INTO VOUCHERS REDEEMABLE FOR CASH, DISPENSE COUPONS FOR DISCOUNTS TO SHOPPERS, AND ACCEPT MONETARY CHARITABLE CONTRIBUTIONS; SELF-SERVICE KIOSKS WHICH CONVERT COINS INTO VOUCHERS REDEEMABLE FOR CASH, SELF-SERVICE KIOSKS AND MACHINES WHICH CONVERT COINS INTO GIFT CARDS, CASH CARDS, DEBIT CARDS AND OTHER STORED VALUE CARDS; SELF-SERVICE KIOSKS AND MACHINES THAT DISPENSE TELEPHONE CALLING CARDS, PREPAID INTERNET CARDS, DVD AND VIDEO RENTALS, AND WHICH ISSUE COUPONS OFFERING DISCOUNTS TO SHOPPERS, ADVERTISE BRAND NAME PRODUCTS TO SHOPPERS, AND ACCEPT CHARITABLE DONATIONS; ELECTRONIC TERMINAL VENDING MACHINE FOR TELEPHONY, SPECIFICALLY, PREPAID LONG DISTANCE, PREPAID WIRELESS, PREPAID INTERNET, PREPAID RESIDENTIAL TELEPHONY AND THE PROVISION OF FINANCIAL SERVICES, NAMELY, CHECK CASHING SERVICES AND ACCEPTING DEPOSITS TO FINANCIAL ACCOUNTS FROM KIOSKS; MAGNETICALLY ENCODED CASH CARDS AND OTHER STORED VALUE CARDS (U.S. CLS. 21, 23, 26, 36 AND 38).

BRIAN PINO, EXAMINING ATTORNEY

CLASS 9—(Continued).

SN 85-162,017. MOBILEMED, LLC, SAN FRANCISCO, CA. FILED 10-27-2010.

MOBILEMED

THE MARK CONSISTS OF STANDARD CHARACTERS WITHOUT CLAIM TO ANY PARTICULAR FONT, STYLE, SIZE, OR COLOR.

FOR COMPUTER PROGRAMS AND DOWNLOADABLE SOFTWARE, NAMELY, A MOBILE MEDICAL COMPUTING DEVICE; TO RECORD LOCATIONS OF PHYSICIAN OR OTHER AUTHORIZED CARE PROVIDER AND PHARMACY VISITS, USING A GLOBAL POSITIONING SATELLITE ACCESS FEATURE OF THE MOBILE MEDICAL COMPUTING DEVICE; TO CREATE A CENTRALIZED DATABASE REGARDING LOCAL CARE RESOURCES FROM THE RECORDED LOCATIONS; TO ACCESS NEGOTIATED REDUCED PRICES FOR PREFERRED HEALTH CARE PRODUCTS FROM WEB-BASED INFORMATION SOURCES; TO DISPLAY THE NEGOTIATED REDUCED PRICES FOR VIEWING BY THE USER; TO RECORD A CONVERSATION BETWEEN A USER OF THE DEVICE AND A HEALTH CARE PROVIDER FOR LATER REVIEW BY THE USER; TO AUTOMATICALLY TRANSCRIBE THE RECORDED CONVERSATION FOR OUTPUT; TO ACCESS ONE OR MORE WEB-BASED PATIENT PORTALS; TO DOWNLOAD MEDICAL HISTORY RECORDS OF A PATIENT FROM THE ONE OR MORE WEB-BASED PORTALS, BASED UPON A USER PROFILE INCLUDING PERSONAL INFORMATION THAT UNIQUELY IDENTIFIES THE PATIENT; TO OUTPUT DATA FROM THE DOWNLOADED MEDICAL HISTORY TO AN AUTHORIZED CARE PROVIDER; TO PROVIDE A SERIES OF SCREEN IMAGES AND TEXTUAL INFORMATION AND/OR VOICE DATA RELATING TO THE SCREEN IMAGES, DESCRIBING A LOGICAL INFORMATION FLOW OF A STANDARD PHYSICIAN'S OR OTHER AUTHORIZED CARE PROVIDER'S OFFICE VISIT; TO PROVIDE ACCESS TO A DATABASE THAT SHOWS DIFFERENTIAL DIAGNOSES (U.S. CLS. 21, 23, 26, 36 AND 38).

JOHN HWANG, EXAMINING ATTORNEY

SN 85-162,651. WATSON, PATRICK, C. DBA NICKEY BONZ, MANHATTAN, NY. FILED 10-27-2010.

RedKarpel Status/Whospaa

THE MARK CONSISTS OF STANDARD CHARACTERS WITHOUT CLAIM TO ANY PARTICULAR FONT, STYLE, SIZE, OR COLOR.

FOR PRE-RECORDED CD'S FEATURING PERFORMANCES BY A MUSICAL GROUP (U.S. CLS. 21, 23, 26, 36 AND 38).

LEIGH CAROLINE CASE, EXAMINING ATTORNEY

CLASS 9—(Continued).

SN 85-168,787. MENGEL, MICHAEL, BERLIN, FED REP GERMANY, FILED 11-4-2010.

ULTRAWARP

THE MARK CONSISTS OF STANDARD CHARACTERS WITHOUT CLAIM TO ANY PARTICULAR FONT, STYLE, SIZE, OR COLOR.

FOR COMPUTER PRODUCTS, NAMELY, A PRINTED CIRCUIT BOARD FOR SPECIFIC PERSONAL COMPUTERS, NAMELY, A CO-PROCESSOR BOARD FOR USE TO ACCELERATE COMPUTER OPERATIONS (U.S. CLS. 21, 23, 26, 36 AND 38).

JOHN E. MICHOS, EXAMINING ATTORNEY

SN 85-174,393. KABUSHIKI KAISHA TOSHIBA, DBA TOSHIBA CORPORATION, MINATO-KU, TOKYO, JAPAN, FILED 11-11-2010.



PRIORITY CLAIMED UNDER SEC. 44(D) ON JAPAN APPLICATION NO. 2010-048183, FILED 6-17-2010, REG. NO. 5406508, DATED 4-15-2011, EXPIRES 4-15-2021.

NO CLAIM IS MADE TO THE EXCLUSIVE RIGHT TO USE "3D", APART FROM THE MARK AS SHOWN.

THE MARK CONSISTS OF THE NUMBER "3" AND THE LETTER "D" IN STYLIZED AND/OR DESIGN FORM.

FOR TELEVISION SETS; GLASSES, NAMELY, 3D GLASSES (U.S. CLS. 21, 23, 26, 36 AND 38).

HOWARD SMIGA, EXAMINING ATTORNEY

SN 85-176,137. SIGNEO USA, LLC, LAKE MARY, FL. FILED 11-13-2010.

PARTY IN A BOX

THE MARK CONSISTS OF STANDARD CHARACTERS WITHOUT CLAIM TO ANY PARTICULAR FONT, STYLE, SIZE, OR COLOR.

FOR AUDIO ELECTRONIC COMPONENTS, NAMELY, SURROUND SOUND SYSTEMS (U.S. CLS. 21, 23, 26, 36 AND 38).

FIRST USE 1-1-2010; IN COMMERCE 1-1-2010.

CARYN GLASSER, EXAMINING ATTORNEY

CLASS 9—(Continued).

SN 85-181,610. ONBOARD SYSTEMS, INC., VANCOUVER, WA. FILED 11-19-2010.

CROPHAWK

THE MARK CONSISTS OF STANDARD CHARACTERS WITHOUT CLAIM TO ANY PARTICULAR FONT, STYLE, SIZE, OR COLOR.

FOR APPARATUS AND INSTRUMENTS FOR MEASURING FLOW, NAMELY, FLOW METERS FOR AERIAL MEASUREMENT OF AGRICULTURAL CHEMICALS, AND OWNER'S MANUALS AND SERVICE MANUALS SOLD AS A UNIT THEREWITH (U.S. CLS. 21, 23, 26, 36 AND 38).

FIRST USE 12-31-1998; IN COMMERCE 12-31-1998.
PATRICIA EVANKO, EXAMINING ATTORNEY

SN 85-181,775. TEAM SMILE, INC., N. KANSAS CITY, MO. FILED 11-20-2010.

My Mobile Dentist

THE MARK CONSISTS OF STANDARD CHARACTERS WITHOUT CLAIM TO ANY PARTICULAR FONT, STYLE, SIZE, OR COLOR.

NO CLAIM IS MADE TO THE EXCLUSIVE RIGHT TO USE "MOBILE DENTIST", APART FROM THE MARK AS SHOWN.

FOR COMPUTER APPLICATION SOFTWARE FOR MOBILE PHONES, HANDHELD COMPUTERS AND PORTABLE MEDIA PLAYERS, NAMELY, SOFTWARE FOR CONNECTING DENTAL PATIENTS WITH THE DENTAL OFFICE (U.S. CLS. 21, 23, 26, 36 AND 38).

TARA PATE, EXAMINING ATTORNEY

SN 85-182,211. LEE OLIVER, HUNTINGTON BEACH, CA. FILED 11-22-2010.



OWNER OF U.S. REG. NOS. 3,724,890 AND 3,901,114. THE MARK CONSISTS OF THE WORD "RAPTOR" AND AN EYE IN STYLIZED FORM.

FOR CASES FOR SUNGLASSES; CHAINS FOR SUNGLASSES; SUNGLASS ACCESSORIES, NAMELY, STRAPS, NECK CORDS AND HEAD STRAPS WHICH RESTRAIN EYEWEAR FROM MOVEMENT ON A WEARER; EYEWEAR, NAMELY, SUNGLASSES; FRAMES FOR SUNGLASSES; SUNGLASSES; SPORTS SUNGLASSES; SUNGLASS CHAINS AND CORDS; SUNGLASS LENSES (U.S. CLS. 21, 23, 26, 36 AND 38).

DAVID HOFFMAN, EXAMINING ATTORNEY

CLASS 9—(Continued).

SN 85-183,208. SQUARE ENIX LIMITED, LONDON, UNITED KINGDOM, FILED 11-23-2010.

A SURVIVOR IS BORN

THE MARK CONSISTS OF STANDARD CHARACTERS WITHOUT CLAIM TO ANY PARTICULAR FONT, STYLE, SIZE, OR COLOR.

OWNER OF UNITED KINGDOM REG. NO. 2564835, DATED 2-11-2011, EXPIRES 11-19-2020.

FOR COMPUTER GAME SOFTWARE; COMPUTER GAMES RECORDED ON COMPUTER DISCS; VIDEO GAME SOFTWARE; VIDEO GAMES RECORDED ON COMPUTER DISCS; ELECTRONIC GAME SOFTWARE FOR MOBILE PHONES; COMPUTER GAME SOFTWARE SUPPLIED ON LINE BY MEANS OF MULTI-MEDIA ELECTRONIC BROADCAST OR NETWORK TRANSMISSION; DOWNLOADABLE ELECTRONIC PUBLICATIONS IN THE NATURE OF NEWSLETTERS AND MAGAZINES FEATURING ELECTRONIC GAMES, COMPUTER GAME STRATEGY GUIDES FEATURING INFORMATION ABOUT VIDEO, COMPUTER, AND ELECTRONIC GAMES PROVIDED BY MEANS OF MULTI-MEDIA ELECTRONIC BROADCAST OR NETWORK TRANSMISSION; DOWNLOADABLE DATA IN THE NATURE OF DOWNLOADABLE ELECTRONIC GAMES FEATURING INFORMATION ABOUT VIDEO, COMPUTER AND ELECTRONIC GAMES PROVIDED BY MEANS OF MULTI-MEDIA ELECTRONIC BROADCAST OR NETWORK TRANSMISSION, DISKS AND TAPES PRE-RECORDED WITH COMPUTER GAME SOFTWARE, VIDEO GAME SOFTWARE, OR OTHER ELECTRONIC PUBLICATIONS IN THE NATURE OF GAME GUIDES HAVING GAMES AS THEIR SUBJECT MATTER (U.S. CLS. 21, 23, 26, 36 AND 38).

CHRISTINA SOBRAL, EXAMINING ATTORNEY

SN 85-184,035. THE INSTITUTE OF ELECTRICAL AND ELECTRONICS ENGINEERS, INC., PISCATAWAY, NJ. FILED 11-23-2010.



THE MARK CONSISTS OF THE STYLIZED LETTERS "CPMT" SUPERIMPOSED UPON AND COMPLETELY FILLING A SHADED ELLIPSE, SURROUNDED BY A BORDER IN THE SHAPE OF AN ELLIPSE.

FOR DOWNLOADABLE ELECTRONIC PUBLICATIONS IN THE NATURE OF JOURNALS AND NEWSLETTERS IN THE FIELD OF ELECTRICAL AND ELECTRONICS ENGINEERING, AND COMPONENTS, PACKAGING, AND MANUFACTURING TECHNOLOGY (U.S. CLS. 21, 23, 26, 36 AND 38).

FIRST USE 11-30-2004; IN COMMERCE 11-30-2004.

MATTHEW PAPPAS, EXAMINING ATTORNEY

CLASS 9—(Continued).

SN 85-184,329. STEINWAY, INC., LONG ISLAND CITY, NY. FILED 11-24-2010.



OWNER OF U.S. REG. NOS. 607,992, 3,737,339 AND OTHERS.

THE MARK CONSISTS OF IN PART THE LETTER "S" FORWARD AND BACKWARD IN CONJUNCTION WITH AN AMPERSAND TO FORM A LYRE.

FOR PRERECORDED CDS FEATURING MUSIC, AUDIO RECORDINGS FEATURING MUSIC, DIGITAL MUSIC RECORDINGS DOWNLOADABLE FROM THE INTERNET (U.S. CLS. 21, 23, 26, 36 AND 38).

FIRST USE 9-28-2010; IN COMMERCE 9-28-2010.
GENE MACIOL, EXAMINING ATTORNEY

CLASS 9—(Continued).

SN 85-190,150. HYUNDAI MOBIS CO., LTD., SEOUL, REPUBLIC OF KOREA, FILED 12-3-2010.



THE MARK CONSISTS OF ITALICIZED CAPITAL LETTERS SPELLING THE WORD "ACTUNE" WITH THE LETTER "A" RESEMBLING A TRIANGLE.

FOR AUDIO-VIDEO RECEIVERS; AUDIO AMPLIFIERS FOR VEHICLES; AUDIO SPEAKERS FOR VEHICLES; AUDIO DISC PLAYERS FOR VEHICLES; RADIOS FOR VEHICLES; SATELLITE NAVIGATIONAL APPARATUS, NAMELY, A GLOBAL POSITIONING SYSTEM (GPS); ELECTRONIC NAVIGATIONAL INSTRUMENTS FOR VEHICLES; COMMUNICATIONS APPARATUS FOR VEHICLES, NAMELY, SATELLITE AND MICROWAVE COMMUNICATIONS APPARATUS TO TRANSMIT COMMUNICATIONS FROM A VEHICLE TO ANOTHER VEHICLE, OR TO A VEHICLE FROM A SATELLITE; ELECTRIC AUDIO AND VISUAL APPARATUS AND INSTRUMENTS, NAMELY, CAR VIDEO RECORDERS; COMPUTER SOFTWARE FOR MANAGING GPS DATA; PRE-RECORDED ELECTRONIC MEDIA FEATURING MUSIC (U.S. CLS. 21, 23, 26, 36 AND 38).

PATRICIA EVANKO, EXAMINING ATTORNEY

SN 85-190,364. COMPETITIVE SPORTS ANALYSIS, LLC, ATLANTA, GA. FILED 12-3-2010.

SN 85-185,289. SSB-ELECTRONIC GMBH, 59557 LIPPSTADT, FED REP GERMANY, FILED 11-25-2010.



ECOFLEX

NO CLAIM IS MADE TO THE EXCLUSIVE RIGHT TO USE "SCOUT", APART FROM THE MARK AS SHOWN.

THE COLOR(S) BLACK, ORANGE AND WHITE IS/ARE CLAIMED AS A FEATURE OF THE MARK.

THE MARK CONSISTS OF A RECTANGULAR DESIGN. THE WORD "SCOUT" IS IN ORANGE WITH A BLACK HORIZONTAL BAR ABOVE AND BELOW IT. THE WORD "PRO" IS NEXT TO IT AND THE LETTERS "PR" ARE IN BLACK. THE LETTER "O" IS IN THE SHAPE OF A SUN DESIGN WITH BLACK AND WHITE LINES COMING OUTWARD FROM A CIRCULAR ORANGE CENTER WITH A WHITE BORDER. THE BACKGROUND OF THE DESIGN IS WHITE.

FOR COMPUTER SOFTWARE THAT ASSISTS FANTASY FOOTBALL PARTICIPANTS OPTIMIZE THEIR ROSTER OF PLAYERS; COMPUTER SOFTWARE THAT ASSISTS COACHES OF SPORTS TEAMS DEVELOP AN OPTIMUM GAME PLAN (U.S. CLS. 21, 23, 26, 36 AND 38).

MAUREEN DALL, EXAMINING ATTORNEY

THE MARK CONSISTS OF STANDARD CHARACTERS WITHOUT CLAIM TO ANY PARTICULAR FONT, STYLE, SIZE, OR COLOR.

FOR ANTENNAS, HIGH FREQUENCY COAXIAL CABLES, HIGH FREQUENCY CABLE CONNECTORS (U.S. CLS. 21, 23, 26, 36 AND 38).

FIRST USE 12-1-2001; IN COMMERCE 12-1-2001.
BERYL GARDNER, EXAMINING ATTORNEY

CLASS 9—(Continued).

SN 85-190,494. MASSIVE CHANGE NETWORK, LLC, WINNETKA, IL. FILED 12-3-2010.

INCOMPLETE MANIFESTO FOR
GROWTH

THE MARK CONSISTS OF STANDARD CHARACTERS WITHOUT CLAIM TO ANY PARTICULAR FONT, STYLE, SIZE, OR COLOR.

FOR DOWNLOADABLE ELECTRONIC EDUCATIONAL MATERIALS IN THE NATURE OF WRITTEN DOCUMENTS IN THE FIELD OF DESIGN METHODOLOGY (U.S. CLS. 21, 23, 26, 36 AND 38).

AMEEN IMAM, EXAMINING ATTORNEY

SN 85-192,324. MULTIPLEX PROPERTIES, INC., WILMINGTON, DE. FILED 12-7-2010.

CINEMODE

THE MARK CONSISTS OF STANDARD CHARACTERS WITHOUT CLAIM TO ANY PARTICULAR FONT, STYLE, SIZE, OR COLOR.

FOR DOWNLOADABLE SOFTWARE IN THE NATURE OF A MOBILE APPLICATION FOR UPLOADING, POSTING, SHOWING, DISPLAYING AND SHARING LIVE VIDEO AND CHAT WITH OTHER USERS OF THE SOFTWARE IN THE FIELD OF MOVIE THEATER OPERATIONS AND MOVIE THEATER RELATED CONSUMER SERVICES, ADVERTISING, AND INCENTIVES (U.S. CLS. 21, 23, 26, 36 AND 38).

DARRYL SPRUILL, EXAMINING ATTORNEY

SN 85-192,626. COMVERGE, INC., NORCROSS, GA. FILED 12-7-2010.

IntelliFOCUS

THE MARK CONSISTS OF STANDARD CHARACTERS WITHOUT CLAIM TO ANY PARTICULAR FONT, STYLE, SIZE, OR COLOR.

FOR DISPLAY DEVICES FOR HEATING, COOLING, AND ENERGY MANAGEMENT; WIRELESS METER READING INSTRUMENTS; THERMOSTATS; APPARATUS FOR TRANSMISSION OF COMMUNICATION AND STORAGE OF INFORMATION, NAMELY, THROUGH METERS, REMOTE TRANSMITTER CONTROLLERS, OR METER DATA STORAGE DEVICES RELATED TO PRICING, CONSUMER USAGE, BILLING AND LOAD FORECASTING; COMPUTER SOFTWARE FOR ELECTRICAL LOAD CONTROL AND MANAGEMENT; COMPUTER SOFTWARE FOR WIRELESS METER DATA COLLECTION, STORAGE AND MANAGEMENT (U.S. CLS. 21, 23, 26, 36 AND 38).

FIRST USE 10-18-2010; IN COMMERCE 10-18-2010.

KATHY DE JONGE, EXAMINING ATTORNEY

CLASS 9—(Continued).

SN 85-192,636. COMVERGE, INC., NORCROSS, GA. FILED 12-7-2010.

IntelliTEMP

THE MARK CONSISTS OF STANDARD CHARACTERS WITHOUT CLAIM TO ANY PARTICULAR FONT, STYLE, SIZE, OR COLOR.

FOR ELECTRIC CONTROL DEVICES FOR HEATING, COOLING, AND ENERGY MANAGEMENT; THERMOSTATS; APPARATUS FOR TRANSMISSION OF COMMUNICATION AND STORAGE OF INFORMATION NAMELY THROUGH METERS, REMOTE TRANSMITTER CONTROLLERS, OR METER DATA STORAGE DEVICES RELATED TO PRICING, CONSUMER USAGE, BILLING AND LOAD FORECASTING; WIRELESS METER READING INSTRUMENTS; COMPUTER SOFTWARE FOR ELECTRICAL LOAD CONTROL AND MANAGEMENT; COMPUTER SOFTWARE FOR WIRELESS METER DATA COLLECTION, STORAGE AND MANAGEMENT (U.S. CLS. 21, 23, 26, 36 AND 38).

FIRST USE 10-18-2010; IN COMMERCE 10-18-2010.

KATHY DE JONGE, EXAMINING ATTORNEY

SN 85-192,933. SQUARE ENIX LIMITED, LONDON, UNITED KINGDOM, FILED 12-8-2010.

BIG CUP

THE MARK CONSISTS OF STANDARD CHARACTERS WITHOUT CLAIM TO ANY PARTICULAR FONT, STYLE, SIZE, OR COLOR.

OWNER OF UNITED KINGDOM REG. NO. 2563368, DATED 1-28-2011, EXPIRES 11-5-2020.

FOR COMPUTER GAME SOFTWARE; COMPUTER GAMES RECORDED ON COMPUTER DISCS; VIDEO GAME SOFTWARE; VIDEO GAMES RECORDED ON COMPUTER DISCS; ELECTRONIC GAME SOFTWARE FOR MOBILE PHONES; COMPUTER GAME SOFTWARE SUPPLIED ON LINE BY MEANS OF MULTI-MEDIA ELECTRONIC BROADCAST OR NETWORK TRANSMISSION; DOWNLOADABLE ELECTRONIC PUBLICATIONS IN THE NATURE OF NEWSLETTERS AND MAGAZINES FEATURING ELECTRONIC GAMES, COMPUTER GAME STRATEGY GUIDES FEATURING INFORMATION ABOUT VIDEO, COMPUTER, AND ELECTRONIC GAMES PROVIDED BY MEANS OF MULTI-MEDIA ELECTRONIC BROADCAST OR NETWORK TRANSMISSION; DOWNLOADABLE DATA IN THE NATURE OF DOWNLOADABLE ELECTRONIC GAMES FEATURING INFORMATION ABOUT VIDEO, COMPUTER AND ELECTRONIC GAMES PROVIDED BY MEANS OF MULTI-MEDIA ELECTRONIC BROADCAST OR NETWORK TRANSMISSION, DISKS AND TAPES PRE-RECORDED WITH COMPUTER GAME SOFTWARE, VIDEO GAME SOFTWARE, OR OTHER ELECTRONIC PUBLICATIONS IN THE NATURE OF GAME GUIDES HAVING GAMES AS THEIR SUBJECT MATTER (U.S. CLS. 21, 23, 26, 36 AND 38).

CHRISTINA SOBRAL, EXAMINING ATTORNEY

CLASS 9—(Continued).

SN 85-193,682. SHERLOCK, MICHAEL T, SEATTLE, WA. FILED 12-8-2010.



NO CLAIM IS MADE TO THE EXCLUSIVE RIGHT TO USE "BOOTLEG RECORDS", APART FROM THE MARK AS SHOWN.

THE MARK CONSISTS OF THE WORDING "BOOTLEG RECORDS" AND THE DESIGN OF THE SILHOUETTE OF A WOMAN IN AN ENTRYWAY WITH THE LETTER "M" WITH HORNS AND HALO POSITIONED INSIDE THE ENTRY.

FOR AUDIO AND VIDEO RECORDINGS FEATURING MUSIC AND ARTISTIC PERFORMANCES (U.S. CLS. 21, 23, 26, 36 AND 38).

FIRST USE 11-29-2010; IN COMMERCE 5-20-2011. BARNEY CHARLON, EXAMINING ATTORNEY

CLASS 9—(Continued).

SN 85-196,350. VAN BORTEL AIRCRAFT, INC., DBA AIR POWER, ARLINGTON, TX. FILED 12-13-2010.

BE GENUINE

THE MARK CONSISTS OF STANDARD CHARACTERS WITHOUT CLAIM TO ANY PARTICULAR FONT, STYLE, SIZE, OR COLOR.

FOR REPLACEMENT PARTS FOR AIRCRAFT, NAMELY, BATTERIES; AVIONIC SENSOR SYSTEMS COMPRISING ENGINE GAUGES, TEMPERATURE GAUGES, TACHOMETERS, OIL PRESSURE GAUGES, AND FUEL SUPPLY GAUGES; AND FLIGHT INSTRUMENTS, NAMELY, ALTIMETERS, AIR SPEED INDICATORS, GYROCOMPASSES, ALTITUDE INDICATORS, MANIFOLD PRESSURE GAUGES, FUEL PRESSURE GAUGES, TACHOMETERS, AND TEMPERATURE SENSORS; AVIONICS RADIO COMMUNICATION SYSTEMS COMPRISING HEADSETS FOR AVIONICS RADIO COMMUNICATIONS, RADAR DISPLAY SCREENS, RADIO AND RADAR ANTENNAE (U.S. CLS. 21, 23, 26, 36 AND 38).

DEBRA LEE, EXAMINING ATTORNEY

SN 85-196,281. POWER GEAR MOTORSPORTS INC., CHICAGO, IL. FILED 12-13-2010.

PGR

THE MARK CONSISTS OF STANDARD CHARACTERS WITHOUT CLAIM TO ANY PARTICULAR FONT, STYLE, SIZE, OR COLOR.

FOR MOTORCYCLE, MOTOCROSS, SNOW, WATER AND OUTDOOR SPORTS GEAR AND ACCESSORIES, NAMELY, MOTORCYCLE HELMETS, RIDING HELMETS, BICYCLE HELMETS, CRASH HELMETS, DIVING HELMETS, HOCKEY HELMETS, SAFETY HELMETS, SPORTS HELMETS, BODY ARMOR, AND EYEWEAR (U.S. CLS. 21, 23, 26, 36 AND 38).

FIRST USE 10-25-2008; IN COMMERCE 10-25-2008. AMEEN IMAM, EXAMINING ATTORNEY

SN 85-197,727. PUSH BUTTON LABS, EUGENE, OR. FILED 12-14-2010.



THE MARK CONSISTS OF THE WORDING "THE LIDDLES" IN STYLIZED FONT, WITH THE INDIVIDUAL LETTERS APPEARING IN VARYING SIZES AND POSITION AND WITH THE LETTER "I" IN THE FORM OF A SMILING FIGURE. A CURVED LINE APPEARS BENEATH THE WORDING.

FOR DOWNLOADABLE COMPUTER GAME SOFTWARE VIA A GLOBAL COMPUTER NETWORK AND WIRELESS DEVICES (U.S. CLS. 21, 23, 26, 36 AND 38).

STEVEN PEREZ, EXAMINING ATTORNEY

CLASS 9—(Continued).

SN 85-197,730. PUSH BUTTON LABS, EUGENE, OR. FILED 12-14-2010.



THE MARK CONSISTS OF THE WORDING "LIDDLES NEIGHBORHOOD" IN STYLIZED FONT WITH THICK OUTLINING. THE INDIVIDUAL LETTERS OF THE WORD "LIDDLES" APPEAR IN VARYING SIZES AND POSITION WITH THE LETTER "I" IN THE FORM OF A SMILING FIGURE. BENEATH IS THE WORD "NEIGHBORHOOD" WITH THE SECOND LETTER "H" IN THE FORM OF A HOUSE. A CURVED LINE SEPARATES THE TWO WORDS.

FOR DOWNLOADABLE COMPUTER GAME SOFTWARE VIA A GLOBAL COMPUTER NETWORK AND WIRELESS DEVICES (U.S. CLS. 21, 23, 26, 36 AND 38).

STEVEN PEREZ, EXAMINING ATTORNEY

SN 85-202,006. PEOPLE PRODUCTIONS VIDEO SERVICES, INC., BOULDER, CO. FILED 12-20-2010.

UPSYNC

THE MARK CONSISTS OF STANDARD CHARACTERS WITHOUT CLAIM TO ANY PARTICULAR FONT, STYLE, SIZE, OR COLOR.

FOR COMPUTER SOFTWARE FOR COLLECTION, EDITING, MANAGEMENT, TRANSMISSION AND SHARING OF DATA, INFORMATION AND BUSINESS, SALES AND MARKETING MATERIALS; DOWNLOADABLE SOFTWARE IN THE NATURE OF A MOBILE APPLICATION FOR COLLECTION, EDITING, MANAGEMENT, TRANSMISSION AND SHARING OF DATA, INFORMATION AND BUSINESS, SALES AND MARKETING MATERIALS (U.S. CLS. 21, 23, 26, 36 AND 38).

CIMMERIAN COLEMAN, EXAMINING ATTORNEY

CLASS 9—(Continued).

SN 85-203,926. LOUISIANA MEDICAL MUTUAL INSURANCE COMPANY, METAIRIE, LA. FILED 12-22-2010.



THE MARK CONSISTS OF THE STYLIZED LETTERS "M" AND "I" WITH A FLOURISH ABOVE THE LETTER "I" AND THE WORD "COMMUNITY" INSIDE THE LETTER "I".

FOR PRERECORDED ELECTRONIC AND DIGITAL MEDIA FEATURING EDUCATIONAL PRESENTATIONS IN THE FIELD OF INSURANCE RISK MANAGEMENT; COMPUTER SOFTWARE FOR USE IN INSURANCE RISK MANAGEMENT, NAMELY, SOFTWARE TOOLS TO ASSIST RISK MANAGERS IN DOCUMENTING, TRACKING, AND ANALYZING SPECIFIC RISK EXPOSURES, PROVIDING BENCHMARKING ABILITY FOR AGGREGATE DATA AND DECISION SUPPORT, APPLYING LOSS REDUCTION STRATEGIES, AND IMPLEMENTING RISK REDUCTION INTERVENTIONS, ALL IN THE FIELD OF MEDICAL MALPRACTICE (U.S. CLS. 21, 23, 26, 36 AND 38).

BRENDAN MCCAULEY, EXAMINING ATTORNEY

SN 85-204,060. LOUISIANA MEDICAL MUTUAL INSURANCE COMPANY, METAIRIE, LA. FILED 12-22-2010.



THE MARK CONSISTS OF THE STYLIZED LETTERS "M" AND "I" WITH A FLOURISH ABOVE THE LETTER "I".

FOR PRERECORDED ELECTRONIC AND DIGITAL MEDIA FEATURING EDUCATIONAL PRESENTATIONS IN THE FIELD OF INSURANCE RISK MANAGEMENT; COMPUTER SOFTWARE FOR USE IN INSURANCE RISK MANAGEMENT, NAMELY, SOFTWARE TOOLS TO ASSIST RISK MANAGERS IN DOCUMENTING, TRACKING, AND ANALYZING SPECIFIC RISK EXPOSURES, PROVIDING BENCHMARKING ABILITY FOR AGGREGATE DATA AND DECISION SUPPORT, APPLYING LOSS REDUCTION STRATEGIES, AND IMPLEMENTING RISK REDUCTION INTERVENTIONS, ALL IN THE FIELD OF MEDICAL MALPRACTICE (U.S. CLS. 21, 23, 26, 36 AND 38).

BRENDAN MCCAULEY, EXAMINING ATTORNEY

CLASS 9—(Continued).

SN 85-205,753. USA111 INC., COLUMBUS, OH. FILED 12-27-2010.

iRULU

THE MARK CONSISTS OF STANDARD CHARACTERS WITHOUT CLAIM TO ANY PARTICULAR FONT, STYLE, SIZE, OR COLOR.

OWNER OF U.S. REG. NO. 3,287,664.

FOR BATTERIES; BATTERIES AND BATTERY CHARGERS; BATTERY CHARGERS; CABLE CONNECTORS; CABLE TELEVISION CONVERTERS; CHARGERS FOR BATTERIES; COMPUTER CABLES; COMPUTER CURSOR CONTROL DEVICES, NAMELY, COMPUTER MOUSE; COMPUTER GAME JOYSTICKS; COMPUTER KEYBOARDS; COMPUTER KEYPADS; COMPUTER MICE; COMPUTER MOUSE; COMPUTER NETWORK ADAPTERS, SWITCHES, ROUTERS AND HUBS; COMPUTER STORAGE DEVICES, NAMELY, BLANK FLASH DRIVES; DIGITAL AUDIO AND VIDEO RECORDERS AND PLAYERS; DIGITAL AUDIO PLAYERS; EARPHONE ACCESSORIES, NAMELY, EARPHONE CUSHIONS, EARPHONE PADS, CORD MANAGEMENT SYSTEMS, EARPHONE CASES, AND EARPHONE EXTENSION CORDS; ELECTRIC CHARGING CABLES; ELECTRONIC EQUIPMENT, NAMELY, TRANSFORMERS, BALUNS, CABLES USED IN CONNECTION WITH COMPUTERS, COMPUTER PERIPHERAL DEVICES, TELEVISIONS, AUDIO-VIDEO EQUIPMENT, CLOSED-CIRCUIT TV EQUIPMENT AND TELECOMMUNICATION EQUIPMENT; FLASH CARD ADAPTERS; FLASH CARD READERS; FLASH MEMORY CARD; LITHIUM ION BATTERIES; MEDIA PLAYERS; MP3 PLAYERS; MP4 PLAYERS; RECHARGEABLE ELECTRIC BATTERIES; USB CABLES (U.S. CLS. 21, 23, 26, 36 AND 38).

SANJEEV VOHRA, EXAMINING ATTORNEY

SN 85-205,977. HATCH TRANSFORMERS INC., TAMPA, FL. FILED 12-27-2010.

Precision Power. Perfect Light.

THE MARK CONSISTS OF STANDARD CHARACTERS WITHOUT CLAIM TO ANY PARTICULAR FONT, STYLE, SIZE, OR COLOR.

NO CLAIM IS MADE TO THE EXCLUSIVE RIGHT TO USE "POWER" AND "LIGHT", APART FROM THE MARK AS SHOWN.

FOR LIGHTING BALLASTS (U.S. CLS. 21, 23, 26, 36 AND 38).

FIRST USE 4-7-2010; IN COMMERCE 4-7-2010.

JACQUELINE A. LAVINE, EXAMINING ATTORNEY

CLASS 9—(Continued).

SN 85-206,790. LIGHTSPEED SYSTEMS CORPORATION, DBA LIGHTSPEED SYSTEMS, BAKERSFIELD, CA. FILED 12-28-2010.

MY BIG CAMPUS

THE MARK CONSISTS OF STANDARD CHARACTERS WITHOUT CLAIM TO ANY PARTICULAR FONT, STYLE, SIZE, OR COLOR.

FOR COMPUTER SOFTWARE FOR CREATING A SECURE ON-LINE COMMUNITY FOR USERS TO PARTICIPATE IN DISCUSSIONS, GET FEEDBACK FROM PEERS AND EDUCATORS, FORM VIRTUAL COMMUNITIES, SHARE RESOURCES, COLLABORATE AND ENGAGE IN ON-LINE NETWORKING (U.S. CLS. 21, 23, 26, 36 AND 38).

FIRST USE 2-1-2010; IN COMMERCE 2-1-2010.

JENNIFER DIXON, EXAMINING ATTORNEY

SN 85-209,493. CLAY BAKER, DBA WEST|280, PORTOLA VALLEY, CA. AND THOMAS RAMIES, DBA WEST|280, PORTOLA VALLEY, CA. FILED 1-3-2011.

BevConX

THE MARK CONSISTS OF STANDARD CHARACTERS WITHOUT CLAIM TO ANY PARTICULAR FONT, STYLE, SIZE, OR COLOR.

FOR COMPUTER SOFTWARE FOR ACCEPTING, VALIDATING, TRANSMITTING, AND PROCESSING CREDIT CARD TRANSACTIONS AND ONLINE PAYMENT TRANSACTIONS; COMPUTER SOFTWARE FOR GENERATING AND SENDING TEXT MESSAGES AND ELECTRONIC MAIL MESSAGES; COMPUTER SOFTWARE FOR DELIVERING AND PROCESSING COUPONS AND VIDEOS ON MOBILE PHONES, SMARTPHONES, AND HANDHELD COMPUTERS (U.S. CLS. 21, 23, 26, 36 AND 38).

COLLEEN KEARNEY, EXAMINING ATTORNEY

CLASS 9—(Continued).

SN 85-212,703. BRIGHTEHR, LLC, LAWRENCE, KS. FILED 1-7-2011.



THE COLOR(S) BLUE, RED, YELLOW IS/ARE CLAIMED AS A FEATURE OF THE MARK.

THE MARK CONSISTS OF THE TERM, "BRIGHTEHR" IN WHICH "BRIGHT" APPEARS IN BLUE AND "EHR" APPEARS IN RED; THE DESIGN OF A YELLOW, ASYMMETRICAL FOUR-POINTED STAR APPEARS ABOVE THE LETTER "G".

FOR COMPUTER SOFTWARE FOR CONTROLLING AND MANAGING PATIENT MEDICAL INFORMATION (U.S. CLS. 21, 23, 26, 36 AND 38).

FIRST USE 10-23-2010; IN COMMERCE 10-23-2010.

KATHERINE E. HALMEN, EXAMINING ATTORNEY

CLASS 9—(Continued).

SN 85-220,807. SPECTRUM TRACKING SYSTEMS, INC., CARROLLTON, TX. FILED 1-19-2011.

BLUETRAC SOLUTIONS

THE MARK CONSISTS OF STANDARD CHARACTERS WITHOUT CLAIM TO ANY PARTICULAR FONT, STYLE, SIZE, OR COLOR.

NO CLAIM IS MADE TO THE EXCLUSIVE RIGHT TO USE "SOLUTIONS", APART FROM THE MARK AS SHOWN.

FOR ELECTRONIC ASSET RECOVERY TRACKING DEVICES FOR USE BY LAW ENFORCEMENT, NAMELY, GPS AND CELLULAR TRACKING DEVICES, TRANSMITTERS AND RECEIVERS, NETWORK INTERFACE DEVICES, MONITORS, ANTENNAS AND BATTERIES; TRACKING DEVICE KITS CONSISTING OF WIRELESS TRANSMITTERS, BATTERIES AND BATTERY CHARGERS, ANTI-STATIC PADS WITH WRIST STRAPS, MAGNETIC DEACTIVATION PLATES AND CONTAINERS FOR DEACTIVATING TRANSMITTERS, DIGITAL SIGNAL PROCESSORS AND RECEIVERS WITH VISUAL AND AUDIO DISPLAYS, EAR BUDS, ANTENNA, CONNECTION CABLES, AND POWER CORDS, SOLD IN VARIOUS COMBINATIONS AS A UNIT, FOR USE BY LAW ENFORCEMENT (U.S. CLS. 21, 23, 26, 36 AND 38).

FIRST USE 4-4-2009; IN COMMERCE 4-4-2009.

KAREN BRACEY, EXAMINING ATTORNEY

SN 85-216,184. HART SYSTEMS, LLC, HAUPPAUGE, NY. FILED 1-12-2011.

HART X4

THE MARK CONSISTS OF STANDARD CHARACTERS WITHOUT CLAIM TO ANY PARTICULAR FONT, STYLE, SIZE, OR COLOR.

FOR SCANNING EQUIPMENT, NAMELY, BAR CODE READERS, FOR PHYSICAL INVENTORY CONTROL (U.S. CLS. 21, 23, 26, 36 AND 38).

DAVID TAYLOR, EXAMINING ATTORNEY

SN 85-220,908. THE BLACK & DECKER CORPORATION, TOWSON, MD. FILED 1-19-2011.

SURE GRIP

THE MARK CONSISTS OF STANDARD CHARACTERS WITHOUT CLAIM TO ANY PARTICULAR FONT, STYLE, SIZE, OR COLOR.

NO CLAIM IS MADE TO THE EXCLUSIVE RIGHT TO USE "GRIP", APART FROM THE MARK AS SHOWN.

FOR LASER LEVEL (U.S. CLS. 21, 23, 26, 36 AND 38).

FIRST USE 5-22-2011; IN COMMERCE 5-22-2011.

TRACY CROSS, EXAMINING ATTORNEY

CLASS 9—(Continued).

SN 85-222,200. TRAKLOK CORPORATION, KNOXVILLE, TN. FILED 1-20-2011.

GEOLOK

THE MARK CONSISTS OF STANDARD CHARACTERS WITHOUT CLAIM TO ANY PARTICULAR FONT, STYLE, SIZE, OR COLOR.

FOR ELECTRONIC LOCK ASSEMBLIES FOR LOCATING, TRACKING, AND SECURING SHIPPING CONTAINERS TO WHICH THE ELECTRONIC LOCK ASSEMBLIES ARE COUPLED (U.S. CLS. 21, 23, 26, 36 AND 38).

ALICE BENMAMAN, EXAMINING ATTORNEY

SN 85-224,200. SPECTRUM TRACKING SYSTEMS, INC., CARROLLTON, TX. FILED 1-24-2011.

ETS SENTRY ALERT

THE MARK CONSISTS OF STANDARD CHARACTERS WITHOUT CLAIM TO ANY PARTICULAR FONT, STYLE, SIZE, OR COLOR.

NO CLAIM IS MADE TO THE EXCLUSIVE RIGHT TO USE "ALERT", APART FROM THE MARK AS SHOWN.

FOR COMPUTER SOFTWARE APPLICATION USED TO TRANSMIT, RECEIVE AND DISPLAY NOTIFICATIONS TO COMPUTERS AND MOBILE TELEPHONES THAT A TRACKING DEVICE HAS BEEN ACTIVATED (U.S. CLS. 21, 23, 26, 36 AND 38).

FIRST USE 9-0-2009; IN COMMERCE 9-0-2009.

KAREN BRACEY, EXAMINING ATTORNEY

SN 85-226,540. BOAB SOFTWARE PTY LTD, AITKENVALE, QUEENSLAND, AUSTRALIA, FILED 1-26-2011.

HELPA

THE MARK CONSISTS OF STANDARD CHARACTERS WITHOUT CLAIM TO ANY PARTICULAR FONT, STYLE, SIZE, OR COLOR.

OWNER OF AUSTRALIA REG. NO. 1036855, DATED 1-10-2005, EXPIRES 1-10-2015.

FOR COMPUTER SOFTWARE FOR PROCESSING AND RECORDING SOIL TEST RESULTS AND OTHER GEOTECHNICAL INFORMATION (U.S. CLS. 21, 23, 26, 36 AND 38).

CHRISTINE MARTIN, EXAMINING ATTORNEY

CLASS 9—(Continued).

SN 85-226,578. DESINNOVA TECHNOLOGIES, INC., PORTLAND, OR. FILED 1-26-2011.



THE COLOR(S) WHITE, BLUE IS/ARE CLAIMED AS A FEATURE OF THE MARK.

THE MARK CONSISTS OF WORD "CAAS" WRITTEN AS UPPER CASE LETTER "C" AND LOWER CASE LETTER "A" AND LOWER CASE LETTER "S", WHICH IS IN WHITE COLOR OVER BLUE BACKGROUND.

FOR HOME AND OFFICE AUTOMATION SYSTEMS COMPRISING WIRELESS AND WIRED CONTROLLERS, CONTROLLED DEVICES, AND SOFTWARE FOR LIGHTING, HVAC, SECURITY, SAFETY AND OTHER HOME AND OFFICE MONITORING AND CONTROL APPLICATIONS; SOFTWARE FOR REMOTE MONITORING, ACTIVATION, AND CONTROL OF WIRELESS AND WIRED CONTROLLERS IN USE WITH AUTOMATED MACHINE SYSTEMS (U.S. CLS. 21, 23, 26, 36 AND 38).

FIRST USE 4-15-2010; IN COMMERCE 4-15-2010.

ELLEN BURNS, EXAMINING ATTORNEY

SN 85-227,443. SQUARE ENIX LIMITED, LONDON, UNITED KINGDOM, FILED 1-27-2011.

BIG HIT BASEBALL

THE MARK CONSISTS OF STANDARD CHARACTERS WITHOUT CLAIM TO ANY PARTICULAR FONT, STYLE, SIZE, OR COLOR.

PRIORITY CLAIMED UNDER SEC. 44(D) ON UNITED KINGDOM APPLICATION NO. 2569063, FILED 1-13-2011, REG. NO. 2569063, DATED 4-15-2011, EXPIRES 1-13-2021.

NO CLAIM IS MADE TO THE EXCLUSIVE RIGHT TO USE "BASEBALL", APART FROM THE MARK AS SHOWN.

FOR COMPUTER GAME SOFTWARE; COMPUTER GAMES RECORDED ON COMPUTER DISCS; VIDEO GAME SOFTWARE; VIDEO GAMES RECORDED ON COMPUTER DISCS; ELECTRONIC GAME SOFTWARE FOR MOBILE PHONES; COMPUTER GAME SOFTWARE SUPPLIED ON LINE BY MEANS OF MULTI-MEDIA ELECTRONIC BROADCAST OR NETWORK TRANSMISSION; DOWNLOADABLE ELECTRONIC PUBLICATIONS IN THE NATURE OF NEWSLETTERS AND MAGAZINES FEATURING ELECTRONIC GAMES, COMPUTER GAME STRATEGY GUIDES FEATURING INFORMATION ABOUT VIDEO, COMPUTER, AND ELECTRONIC GAMES PROVIDED BY MEANS OF MULTI-MEDIA ELECTRONIC BROADCAST OR NETWORK TRANSMISSION; DOWNLOADABLE DATA IN THE NATURE OF DOWNLOADABLE ELECTRONIC GAMES FEATURING INFORMATION ABOUT VIDEO, COMPUTER AND ELECTRONIC GAMES PROVIDED BY MEANS OF MULTI-MEDIA ELECTRONIC BROADCAST OR NETWORK TRANSMISSION, DISKS AND TAPES PRE-RECORDED WITH COMPUTER GAME SOFTWARE, VIDEO GAME SOFTWARE, OR OTHER ELECTRONIC PUBLICATIONS IN THE NATURE OF GAME GUIDES HAVING GAMES AS THEIR SUBJECT MATTER (U.S. CLS. 21, 23, 26, 36 AND 38).

CHRISTINA SOBRAL, EXAMINING ATTORNEY

CLASS 9—(Continued).

SN 85-228,978. STATE FARM MUTUAL AUTOMOBILE INSURANCE COMPANY, BLOOMINGTON, IL. FILED 1-28-2011.

On The Move

THE MARK CONSISTS OF STANDARD CHARACTERS WITHOUT CLAIM TO ANY PARTICULAR FONT, STYLE, SIZE, OR COLOR.

FOR ELECTRONIC TEXT-MESSAGING SOFTWARE APPLICATION FOR USE IN CONJUNCTION WITH SMART PHONES (U.S. CLS. 21, 23, 26, 36 AND 38).

FIRST USE 8-23-2010; IN COMMERCE 8-23-2010.

DAVID ELTON, EXAMINING ATTORNEY

SN 85-233,276. REINHARDT AMPS, LLC, BEDFORD, VA. FILED 2-3-2011.

REINHARDT

THE MARK CONSISTS OF STANDARD CHARACTERS WITHOUT CLAIM TO ANY PARTICULAR FONT, STYLE, SIZE, OR COLOR.

SEC. 2(F).

FOR ELECTRONIC EQUIPMENT FOR MUSICAL INSTRUMENTS, NAMELY, MUSICAL INSTRUMENT AMPLIFIERS, SPEAKER CABINETS, AUDIO SIGNAL PROCESSORS AND PARTS THEREFOR, NAMELY, AUDIO SPEAKERS AND EFFECT PEDALS FOR USE WITH MUSICAL INSTRUMENT AMPLIFIERS (U.S. CLS. 21, 23, 26, 36 AND 38).

FIRST USE 5-20-2004; IN COMMERCE 6-8-2004.

BRIAN CALLAGHAN, EXAMINING ATTORNEY

SN 85-233,379. CONVERGENT NETWORKS, INC., BILLERICA, MA. FILED 2-3-2011.

Convergent Networks

THE MARK CONSISTS OF STANDARD CHARACTERS WITHOUT CLAIM TO ANY PARTICULAR FONT, STYLE, SIZE, OR COLOR.

OWNER OF U.S. REG. NOS. 2,432,346 AND 2,600,150.

NO CLAIM IS MADE TO THE EXCLUSIVE RIGHT TO USE "NETWORKS", APART FROM THE MARK AS SHOWN.

SEC. 2(F).

FOR TELECOMMUNICATIONS AND NETWORKING INFRASTRUCTURE EQUIPMENT, NAMELY, COMPUTER HARDWARE AND SOFTWARE FOR USE BY TELECOMMUNICATIONS CARRIERS AND NETWORK SERVICE PROVIDERS TO DELIVER DATA AND VOICE COMMUNICATION SERVICES (U.S. CLS. 21, 23, 26, 36 AND 38).

FIRST USE 7-28-1998; IN COMMERCE 7-28-1998.

WARREN L. OLANDRIA, EXAMINING ATTORNEY

CLASS 9—(Continued).

SN 85-233,401. AAR HOLDINGS, INC., VAN NUYS, CA. FILED 2-3-2011.

ISYMPHONY

THE MARK CONSISTS OF STANDARD CHARACTERS WITHOUT CLAIM TO ANY PARTICULAR FONT, STYLE, SIZE, OR COLOR.

OWNER OF U.S. REG. NO. 3,516,501.

FOR CONSUMER ELECTRONICS, NAMELY, TELEVISION RECEIVERS; TELEVISION SETS; TELEVISIONS; TELEVISION MONITORS; DVD RECORDERS AND PLAYERS (U.S. CLS. 21, 23, 26, 36 AND 38).

FIRST USE 11-30-2009; IN COMMERCE 11-30-2009.

KELLY CHOE, EXAMINING ATTORNEY

SN 85-234,335. CHUBB, STEVEN, E II, DBA UN4GIVEN SOUNDS, COLUMBUS, OH. FILED 2-4-2011.

Un4given Sounds

THE MARK CONSISTS OF STANDARD CHARACTERS WITHOUT CLAIM TO ANY PARTICULAR FONT, STYLE, SIZE, OR COLOR.

NO CLAIM IS MADE TO THE EXCLUSIVE RIGHT TO USE "SOUNDS", APART FROM THE MARK AS SHOWN.

FOR AUDIO AND VIDEO RECORDINGS FEATURING MUSIC AND ARTISTIC PERFORMANCES; AUDIO SPEAKERS THAT MAY BE ATTACHED WITH ADHESIVE TO THE ABDOMINAL AREA OF PREGNANT WOMEN FOR THE PURPOSE OF TRANSMITTING MUSIC/SOUNDS TO THE FETUS, NOT FOR MEDICAL PURPOSES; AUDIO TAPES FEATURING MUSIC; COMPACT DISC PLAYERS; COMPACT DISCS FEATURING MUSIC; COMPACT DISCS FEATURING MUSIC AND SPOKEN WORD IN THE FORM OF POETRY; COMPUTER HARDWARE AND SOFTWARE FOR PROCESSING DIGITAL MUSIC FILES; COMPUTER PROGRAMS FOR PROCESSING DIGITAL MUSIC FILES; COMPUTER SOFTWARE FEATURING MUSICAL SOUND RECORDINGS AND MUSICAL VIDEO RECORDINGS; COMPUTER SOFTWARE FOR CREATING AND EDITING MUSIC AND SOUNDS; COMPUTER SOFTWARE FOR PROCESSING DIGITAL MUSIC FILES; DIGITAL MUSIC DOWNLOADABLE FROM THE INTERNET; DIGITAL MUSIC SYSTEM THAT SYNCHRONIZES DIGITAL MUSIC FILES STORED ON A HOME UNIT AND A CAR UNIT; DIGITAL MUSIC SYSTEMS THAT SYNCHRONIZES DIGITAL RADIO FILES STORED ON A HOME UNIT, A CAR UNIT, OR PORTABLE UNIT AND THAT MAY BE BACKED UP TO AN INTERNET DEPOSITORY; DIGITAL PHOTO FRAMES FOR DISPLAYING DIGITAL PICTURES, VIDEO CLIPS AND MUSIC; DOWNLOADABLE MP3 FILES, MP3 RECORDINGS, ON-LINE DISCUSSION BOARDS, WEBCASTS, WEBINARS AND PODCASTS FEATURING MUSIC, AUDIO BOOKS IN

CLASS 9—(Continued).

THE FIELD OF ENTERTAINMENT, AND NEWS BROADCASTS; DOWNLOADABLE MUSICAL SOUND RECORDINGS; DOWNLOADABLE RING TONES, GRAPHICS AND MUSIC VIA A GLOBAL COMPUTER NETWORK AND WIRELESS DEVICES; DOWNLOADABLE SONGS VIA THE INTERNET AND WIRELESS DEVICES; ELECTRICAL VOICE INTRACOMMUNICATIONS SYSTEMS COMPRISING CONTROL STATIONS, INTERFACE MODULES, FRAMES, CONTROLLER CARDS, CONNECTORS, POWER SUPPLIES, PANELS AND MOUNTINGS FOR USE IN THE PRODUCTION OF LIVE MUSICAL PERFORMANCES, THEATRE, AND OTHER LIVE EVENTS; INTERACTIVE MUSIC MANUSCRIPT IN MULTIMEDIA VIDEO GAME FORMAT DISTRIBUTED AS DOWNLOADABLE OR DIGITAL MEDIA; MUSICAL RECORDINGS; MUSICAL SOUND RECORDINGS; MUSICAL VIDEO RECORDINGS; PHONOGRAPH RECORDS FEATURING MUSIC; SERIES OF MUSICAL SOUND RECORDINGS; VISUAL RECORDINGS AND AUDIOVISUAL RECORDINGS FEATURING MUSIC AND ANIMATION (U.S. CLS. 21, 23, 26, 36 AND 38).

LOURDES AYALA, EXAMINING ATTORNEY

SN 85-239,484. BONNETT, DOVELL, LADERA RANCH, CA. FILED 2-10-2011.

Password Concierge

THE MARK CONSISTS OF STANDARD CHARACTERS WITHOUT CLAIM TO ANY PARTICULAR FONT, STYLE, SIZE, OR COLOR.

NO CLAIM IS MADE TO THE EXCLUSIVE RIGHT TO USE "PASSWORD", APART FROM THE MARK AS SHOWN.

FOR APPLICATION SOFTWARE, NAMELY, SOFTWARE FOR COMPUTERS, SMARTPHONES AND HANDHELD COMPUTERS FOR USE IN SECURE LOGIN ACCESS TO COMPUTERS, SMARTPHONES, HANDHELD COMPUTERS, WIRELESS NETWORKS, INTERNET, EXTRANET, INTRANET AND COMPUTER APPLICATIONS (U.S. CLS. 21, 23, 26, 36 AND 38).

NAPOLEON SHARMA, EXAMINING ATTORNEY

SN 85-241,292. J. SCHNEIDER POWER SUPPLIES, INC., ATLANTA, GA. FILED 2-14-2011.

J. Schneider Power Supplies, Inc.

THE MARK CONSISTS OF STANDARD CHARACTERS WITHOUT CLAIM TO ANY PARTICULAR FONT, STYLE, SIZE, OR COLOR.

NO CLAIM IS MADE TO THE EXCLUSIVE RIGHT TO USE "POWER SUPPLIES, INC.", APART FROM THE MARK AS SHOWN.

THE NAME(S), PORTRAIT(S), AND/OR SIGNATURE(S) SHOWN IN THE MARK DOES NOT IDENTIFY A PARTICULAR LIVING INDIVIDUAL.

FOR DRY-TYPE TRANSFORMERS; OIL TRANSFORMERS; LOW AND HIGH VOLTAGE ELECTRICAL POWER SUPPLIES; DC-UPS-SYSTEMS, NAMELY, DIRECT CURRENT UNINTERRUPTIBLE ELECTRICAL POWER SUPPLIES; MAGNETIC VOLTAGE STABILIZERS; TRANSFORMER-TYPE VOLTAGE STABILIZERS (U.S. CLS. 21, 23, 26, 36 AND 38).

GRETTA YAO, EXAMINING ATTORNEY

CLASS 9—(Continued).

SN 85-242,781. ENVIRONMENTAL ACCOUSTICAL RESEARCH, INC., DBA E.A.R., INC., BOULDER, CO. FILED 2-15-2011.

HearDefenders-DF

THE MARK CONSISTS OF STANDARD CHARACTERS WITHOUT CLAIM TO ANY PARTICULAR FONT, STYLE, SIZE, OR COLOR.

FOR EAR PLUGS NOT FOR MEDICAL PURPOSES (U.S. CLS. 21, 23, 26, 36 AND 38).

FIRST USE 2-14-2011; IN COMMERCE 2-14-2011.

FONG HSU, EXAMINING ATTORNEY

SN 85-247,483. RMZ DEVELOPMENT LLC, NEW YORK, NY. FILED 2-21-2011.



NO CLAIM IS MADE TO THE EXCLUSIVE RIGHT TO USE "STREAM", APART FROM THE MARK AS SHOWN.

THE COLOR(S) ORANGE, PINK, BLACK AND WHITE IS/ARE CLAIMED AS A FEATURE OF THE MARK.

THE MARK CONSISTS OF THE STYLIZED WORDING "MY STREAM" IN THE COLOR BLACK. BETWEEN THE STYLIZED BLACK WORDS "MY" AND "STREAM" IS AN ORANGE SIGNAL RADIATING CONCENTRIC RINGS THAT FADE FROM ORANGE TO PINK. THE ALTERNATING RINGS THAT RADIATE FROM THE SIGNAL ARE WHITE.

FOR DOWNLOADABLE COMPUTER SOFTWARE FOR ENCODING DATA INTO A NETWORK STREAMABLE FORMAT (U.S. CLS. 21, 23, 26, 36 AND 38).

BERYL GARDNER, EXAMINING ATTORNEY

SN 85-247,525. RMZ DEVELOPMENT LLC, NEW YORK, NY. FILED 2-21-2011.



THE COLOR(S) ORANGE, PINK AND WHITE IS/ARE CLAIMED AS A FEATURE OF THE MARK.

THE MARK CONSISTS OF AN ORANGE SIGNAL RADIATING CONCENTRIC RINGS THAT FADE FROM ORANGE TO PINK. THE ALTERNATING RINGS THAT RADIATE FROM THE SIGNAL ARE WHITE.

FOR DOWNLOADABLE COMPUTER SOFTWARE FOR ENCODING DATA INTO A NETWORK STREAMABLE FORMAT (U.S. CLS. 21, 23, 26, 36 AND 38).

BERYL GARDNER, EXAMINING ATTORNEY

CLASS 9—(Continued).

SN 85-251,615. SIROTA, JACOB M, LANHAM, MD. FILED 2-25-2011.

VioView

THE MARK CONSISTS OF STANDARD CHARACTERS WITHOUT CLAIM TO ANY PARTICULAR FONT, STYLE, SIZE, OR COLOR.

FOR COMPUTER SOFTWARE FOR VIEWING AND PROCESSING POTENTIAL RED LIGHT OR SPEEDING VIOLATIONS (U.S. CLS. 21, 23, 26, 36 AND 38).

FIRST USE 10-1-2007; IN COMMERCE 10-1-2007.

KAREN K. BUSH, EXAMINING ATTORNEY

CLASS 9—(Continued).

SN 85-253,440. H + 10, INC., FREDERICK, MD. FILED 2-28-2011.

POWER-CHAIN

THE MARK CONSISTS OF STANDARD CHARACTERS WITHOUT CLAIM TO ANY PARTICULAR FONT, STYLE, SIZE, OR COLOR.

FOR ELECTRICAL CORDS, CABLES AND CONNECTORS FOR CONNECTING PEDALS AND AMPLIFIERS (U.S. CLS. 21, 23, 26, 36 AND 38).

FIRST USE 3-22-2010; IN COMMERCE 3-22-2010.

NAKWAMA ANKRAH, EXAMINING ATTORNEY

SN 85-252,249. PROTEK INNOVATIONS, LLC, SEDONA, AZ. FILED 2-25-2011.

WAVEZORB

THE MARK CONSISTS OF STANDARD CHARACTERS WITHOUT CLAIM TO ANY PARTICULAR FONT, STYLE, SIZE, OR COLOR.

FOR SAFETY DEVICES, NAMELY, STICKERS AND PATCHES APPLIED TO ELECTRONIC DEVICES FOR PROTECTING USERS FROM ELECTROMAGNETIC RADIATION EMANATING THEREFROM (U.S. CLS. 21, 23, 26, 36 AND 38).

KEVON CHISOLM, EXAMINING ATTORNEY

SN 85-254,011. F-PRIMESTUDIOS INC., WESTMONT, IL. FILED 2-28-2011.

The Dirty Mind Test

SN 85-253,370. DR. DONALD LEWIS, EUCLID, OH. FILED 2-28-2011.

PAT

THE MARK CONSISTS OF STANDARD CHARACTERS WITHOUT CLAIM TO ANY PARTICULAR FONT, STYLE, SIZE, OR COLOR.

FOR COMPUTER SOFTWARE FOR USE IN DETECTING AND PREVENTING FRAUD AND EMBEZZLEMENT IN THE FIELDS OF DENTISTRY, MEDICINE, VETERINARY SERVICES AND OTHER BUSINESSES (U.S. CLS. 21, 23, 26, 36 AND 38).

JAMES LOVELACE, EXAMINING ATTORNEY

THE MARK CONSISTS OF STANDARD CHARACTERS WITHOUT CLAIM TO ANY PARTICULAR FONT, STYLE, SIZE, OR COLOR.

NO CLAIM IS MADE TO THE EXCLUSIVE RIGHT TO USE "TEST", APART FROM THE MARK AS SHOWN.

FOR COMPUTER GAME PROGRAMS; COMPUTER GAME SOFTWARE; COMPUTER GAME SOFTWARE FOR PERSONAL COMPUTERS AND HOME VIDEO GAME CONSOLES; COMPUTER GAME SOFTWARE FOR USE ON MOBILE AND CELLULAR PHONES; COMPUTER GAME SOFTWARE FOR USE WITH PERSONAL COMPUTERS, HOME VIDEO GAME CONSOLES USED WITH TELEVISIONS AND ARCADE-BASED VIDEO GAME CONSOLES (U.S. CLS. 21, 23, 26, 36 AND 38).

KEVIN CORWIN, EXAMINING ATTORNEY

CLASS 9—(Continued).

SN 85-254,348. VEGA GRIESHABER GMBH & CO., SCHIL-
TACH, FED REP GERMANY, FILED 3-1-2011.

VEGA AMERICAS

THE MARK CONSISTS OF STANDARD CHARACTERS
WITHOUT CLAIM TO ANY PARTICULAR FONT, STYLE,
SIZE, OR COLOR.

FOR ELECTRONIC AMPLIFIERS AND ELECTRICAL
CIRCUIT ASSEMBLIES BOTH FOR MEASUREMENTS
IN ALL OF THE FOLLOWING: INDUSTRIAL APPLICA-
TIONS, RADIATION DENSITY GAUGES, PULSE RA-
DARS, LEVEL DETECTION MEASUREMENT
INSTRUMENTS, ELECTRO MECHANICAL GAUGES
FOR MEASUREMENT OF LIQUIDS, PASTES, POWERS
AND GRANULARS, LEVEL GAUGES, THICKNESS
GAUGES, GAUGES FOR WEIGHING MATERIALS ON
BELTS, RADIATION SOURCE HOLDERS AND RADIATION
SOURCE STORAGE CONTAINERS DESIGNED
FOR THE SAFE CONTAINMENT OF RADIATION MA-
TERIAL (U.S. CLS. 21, 23, 26, 36 AND 38).

LINDA E. BLOHM, EXAMINING ATTORNEY

SN 85-255,163. TODD BACHMANN, VANCOUVER, WA.
FILED 3-1-2011.

Flash Mob

THE MARK CONSISTS OF STANDARD CHARACTERS
WITHOUT CLAIM TO ANY PARTICULAR FONT, STYLE,
SIZE, OR COLOR.

NO CLAIM IS MADE TO THE EXCLUSIVE RIGHT TO
USE "FLASH", APART FROM THE MARK AS SHOWN.

FOR DOWNLOADABLE SOFTWARE IN THE NATURE
OF A MOBILE APPLICATION FOR USERS TO CREATE
AND SHARE A WORD, PHRASE, AND/OR PICTURE
WITH OTHER USERS AS A GROUP SO THAT EACH
MOBILE DEVICE WILL DISPLAY A PORTION OF THE
WORD, PHRASE AND/OR PICTURE FOR THE PUR-
POSE OF CREATING SPECIFIC MESSAGES AND/OR
PICTURES ACROSS A ROW OF MOBILE PHONES
PLACED NEXT TO ONE ANOTHER (U.S. CLS. 21, 23,
26, 36 AND 38).

WENDY GOODMAN, EXAMINING ATTORNEY

CLASS 9—(Continued).

SN 85-256,208. PLUS/MINUS YADA YADA, LLC, WOOD-
LAND HILLS, CA. FILED 3-2-2011.

SCORE SOUNDER

THE MARK CONSISTS OF STANDARD CHARACTERS
WITHOUT CLAIM TO ANY PARTICULAR FONT, STYLE,
SIZE, OR COLOR.

NO CLAIM IS MADE TO THE EXCLUSIVE RIGHT TO
USE "SCORE", APART FROM THE MARK AS SHOWN.

FOR COMPUTER APPLICATION SOFTWARE FOR
TRANSMITTING SPORTS INFORMATION TO MOBILE
TELEPHONES AND OTHER HANDHELD ELECTRONIC
DEVICES (U.S. CLS. 21, 23, 26, 36 AND 38).

DAWN HAN, EXAMINING ATTORNEY

SN 85-256,755. PLUS/MINUS YADA YADA, LLC, WOOD-
LAND HILLS, CA. FILED 3-3-2011.

SOUNDER

THE MARK CONSISTS OF STANDARD CHARACTERS
WITHOUT CLAIM TO ANY PARTICULAR FONT, STYLE,
SIZE, OR COLOR.

FOR COMPUTER APPLICATION SOFTWARE FOR
TRANSMITTING SPORTS INFORMATION TO MOBILE
TELEPHONES AND OTHER HANDHELD ELECTRONIC
DEVICES (U.S. CLS. 21, 23, 26, 36 AND 38).

DAWN HAN, EXAMINING ATTORNEY

SN 85-258,392. THIRD SOLUTIONS, INC., MIAMI BEACH,
FL. FILED 3-4-2011.

Natural Savings

THE MARK CONSISTS OF STANDARD CHARACTERS
WITHOUT CLAIM TO ANY PARTICULAR FONT, STYLE,
SIZE, OR COLOR.

FOR COMPUTER SOFTWARE FOR PROVIDING AN
ON-LINE DATABASE IN THE FIELD OF TRANSACTION
PROCESSING TO UPLOAD TRANSACTIONAL
DATA, PROVIDE STATISTICAL ANALYSIS, AND PRO-
DUCE NOTIFICATIONS AND REPORTS (U.S. CLS. 21,
23, 26, 36 AND 38).

FIRST USE 2-21-2011; IN COMMERCE 2-21-2011.

SUSAN RICHARDS, EXAMINING ATTORNEY

CLASS 9—(Continued).

SN 85-260,806. STRUCTURE WORKS, LLC, LAKEWOOD, CO. FILED 3-8-2011.



piece
tracker

NO CLAIM IS MADE TO THE EXCLUSIVE RIGHT TO USE "PIECE TRACKER", APART FROM THE MARK AS SHOWN.

THE COLOR(S) BLUE AND GRAY IS/ARE CLAIMED AS A FEATURE OF THE MARK.

THE MARK CONSISTS OF THE LOWER-CASE WORDING "PIECE TRACKER", "PIECE" IN THE COLOR BLUE AND "TRACKER" IN THE COLOR GRAY. THE LETTERS "P" IN "PIECE" AND "C" IN "TRACKER" ARE STYLIZED TO CONTAIN CROSSHAIRS, AT THE CENTER OF WHICH IS A BLUE DOT.

FOR COMPUTER PROGRAMS RECORDED ON DATA MEDIA (SOFTWARE) DESIGNED FOR USE IN CONSTRUCTION AND AUTOMATED MANUFACTURING (CAD/CAM); COMPUTER SOFTWARE FOR THE COLLECTION, EDITING, ORGANIZING, MODIFYING, BOOK MARKING, TRANSMISSION, STORAGE AND SHARING OF DATA AND INFORMATION; COMPUTER SOFTWARE FOR THE FIELD OF WAREHOUSING AND DISTRIBUTION, TO MANAGE TRANSACTIONAL DATA, PROVIDE STATISTICAL ANALYSIS, AND PRODUCE NOTIFICATIONS AND REPORTS; COMPUTER SOFTWARE FOR TRACKING AND MANAGEMENT OF PRECAST CONCRETE PIECES; COMPUTER SOFTWARE TO MONITOR AND CONTROL FACTORY MANUFACTURING PROCESSES (U.S. CLS. 21, 23, 26, 36 AND 38).

FIRST USE 6-1-2010; IN COMMERCE 6-1-2010.

WENDY JUN, EXAMINING ATTORNEY

CLASS 9—(Continued).

SN 85-261,171. TWO BROTHERS RACING, INC., SANTA ANA, CA. FILED 3-8-2011.



THE COLOR(S) GREY AND ORANGE IS/ARE CLAIMED AS A FEATURE OF THE MARK.

THE MARK CONSISTS OF THE WORD "ROKFORM" IN STYLIZED GREY FONT WITH AN ORANGE TRIANGLE BETWEEN THE LETTERS "K" AND "F". ABOVE THE WORD IS A GREY DESIGN CONSISTING OF A CIRCLE WITH 12 SMALLER, SOLID CIRCLES INSIDE THE CIRCLE AND A SINGLE SOLID CIRCLE INSIDE THE 12 SMALLER, SOLID CIRCLES. THE AREA WITHIN THE CIRCLE IS INTENDED TO BE TRANSLUCENT.

FOR EARPHONES AND HEADPHONES; AUDIO SPEAKERS; BATTERY CHARGERS AND POWER ACCESSORIES, NAMELY, ADAPTORS, CAPACITORS, CONVERTERS, ELECTRICAL CELLS, AND COUPLERS, FOR ELECTRONIC DEVICES; PROTECTIVE COVERS FOR ELECTRONIC DEVICES, NAMELY, CELL PHONES, MP3 PLAYERS, TABLET COMPUTERS, PERSONAL MUSIC PLAYERS, HANDHELD COMPUTERS, HANDHELD GAMING DEVICES, LAPTOPS, AND MEDIA PLAYERS; PROTECTIVE CASES FOR ELECTRONIC DEVICES, NAMELY, CELL PHONES, MP3 PLAYERS, TABLET COMPUTERS, PERSONAL MUSIC PLAYERS, HANDHELD COMPUTERS, HANDHELD GAMING DEVICES, LAPTOPS, AND MEDIA PLAYERS; FITTED PLASTIC FILMS KNOWN AS SKINS FOR COVERING AND PROTECTING ELECTRONIC APPARATUS FOR ELECTRONIC APPARATUS, NAMELY, CELL PHONES, MP3 PLAYERS, TABLET COMPUTERS, PERSONAL MUSIC PLAYERS, HANDHELD COMPUTERS, HANDHELD GAMING DEVICES, LAPTOPS, AND MEDIA PLAYERS; CASES AND CONTAINERS SPECIFICALLY ADAPTED FOR HOLDING OR CARRYING ELECTRONIC DEVICES, NAMELY, CELL PHONES, MP3 PLAYERS, TABLET COMPUTERS, PERSONAL MUSIC PLAYERS, HANDHELD COMPUTERS, HANDHELD GAMING DEVICES, LAPTOPS, AND MEDIA PLAYERS; PROTECTIVE SLEEVES AND ARMBANDS FOR ELECTRONIC DEVICES, NAMELY, CELL PHONES, MP3 PLAYERS, TABLET COMPUTERS, PERSONAL MUSIC PLAYERS, HANDHELD COMPUTERS, HANDHELD GAMING DEVICES, LAPTOPS, AND MEDIA PLAYERS; MEDIA PLAYERS; ELECTRIC CABLES; DIGITAL AUDIO COMPONENTS, NAMELY, PERSONAL RADIO AND VIDEO TUNERS AND TRANSMITTERS; ELECTRICAL AND ELECTRONIC CONNECTORS; MOBILE MEDIA DEVICE SOFTWARE AND APPLICATIONS FOR CREATING AND BUYING PROTECTIVE CASES; HOLDERS FOR ELECTRONIC DEVICES, NAMELY, CELL PHONES, MP3 PLAYERS, TABLET COMPUTERS, PERSONAL MUSIC PLAYERS, HANDHELD COMPUTERS, COMPUTER MONITORS, HANDHELD GAMING DEVICES, LAPTOPS, AND MEDIA PLAYERS FOR ELECTRONIC DEVICES (U.S. CLS. 21, 23, 26, 36 AND 38).

DORITT L. CARROLL, EXAMINING ATTORNEY

CLASS 9—(Continued).

SN 85-261,492. ORANGE 21 NORTH AMERICA INC., CARLSBAD, CA. FILED 3-8-2011.

PLATOON

THE MARK CONSISTS OF STANDARD CHARACTERS WITHOUT CLAIM TO ANY PARTICULAR FONT, STYLE, SIZE, OR COLOR.

FOR SPORTS GOGGLES (U.S. CLS. 21, 23, 26, 36 AND 38).

COLLEEN KEARNEY, EXAMINING ATTORNEY

SN 85-263,080. ROCKY MOUNTAIN SPRING WATER CO., HINGHAM, MA. FILED 3-10-2011.

AQUA EXPRESS

THE MARK CONSISTS OF STANDARD CHARACTERS WITHOUT CLAIM TO ANY PARTICULAR FONT, STYLE, SIZE, OR COLOR.

NO CLAIM IS MADE TO THE EXCLUSIVE RIGHT TO USE "AQUA", APART FROM THE MARK AS SHOWN.

FOR AUTOMATED VENDING APPARATUS, NAMELY, LARGE-VOLUME BOTTLED WATER VENDING MACHINES INCLUDING A WATER BOTTLE VENDING SEGMENT AND A WATER BOTTLE RETURN SEGMENT COMBINED WITH AN ELECTRONIC TRANSACTION APPARATUS TO ALLOW PAPERLESS DEBIT/CREDIT AND PROMOTIONAL TRANSACTIONS FOR THE PURCHASE OF FILLED WATER BOTTLES AND THE RETURN OF EMPTIED RE-USABLE WATER BOTTLES (U.S. CLS. 21, 23, 26, 36 AND 38).

ANNE MADDEN, EXAMINING ATTORNEY

SN 85-264,625. LEADING COMMUNICATORS INC., TORONTO, ONTARIO, CANADA, FILED 3-11-2011.

speakcheck

THE MARK CONSISTS OF STANDARD CHARACTERS WITHOUT CLAIM TO ANY PARTICULAR FONT, STYLE, SIZE, OR COLOR.

OWNER OF CANADA REG. NO. TMA628,327, DATED 12-14-2004, EXPIRES 12-14-2019.

OWNER OF U.S. REG. NO. 2,948,501.

FOR COMPUTER SOFTWARE TO ENABLE THE COACHING AND CRITIQUING OF SPEECHES, PRESENTATIONS, MEDIA INTERVIEWS AND OTHER VERBAL, WRITTEN AND AUDIOVISUAL COMMUNICATIONS (U.S. CLS. 21, 23, 26, 36 AND 38).

LAURA KOVALSKY, EXAMINING ATTORNEY

CLASS 9—(Continued).

SN 85-265,601. PT-ME, LLC, PLAY VISTA, CA. FILED 3-13-2011.



THE COLOR(S) BLUE, LIGHT BLUE, YELLOW AND WHITE IS/ARE CLAIMED AS A FEATURE OF THE MARK.

THE MARK CONSISTS OF RECTANGULAR SHAPE WITH ROUNDED EDGES. THE BORDER OF THIS SHAPE CONSISTS OF 2 COLOR LINES IN BLUE ON THE OUTER EDGE AND LIGHT BLUE ON THE INNER EDGE. THE INSIDE OF THE SHAPE IS IN BLUE TO LIGHT BLUE TO WHITE SHADING FROM THE BOTTOM TO THE TOP WITH THE LETTERS "PT" IN A DARK BLUE AND BLUE STYLIZED FONT, A DASH IN DARK BLUE AND BLUE AND THE LETTERS "ME" IN A YELLOW STYLIZED FONT WITH A WHITE BORDER.

FOR COMPUTER APPLICATION SOFTWARE FOR MOBILE PHONES, NAMELY, SOFTWARE CONTAINING INFORMATION IN THE FIELD OF THERAPY ADVICE (U.S. CLS. 21, 23, 26, 36 AND 38).

FIRST USE 3-13-2011; IN COMMERCE 3-13-2011.

ERNEST SHOSHO, EXAMINING ATTORNEY

SN 85-267,086. THE PROCTER & GAMBLE COMPANY, CINCINNATI, OH. FILED 3-15-2011.

ACCUTARGET EXPRESS

THE MARK CONSISTS OF STANDARD CHARACTERS WITHOUT CLAIM TO ANY PARTICULAR FONT, STYLE, SIZE, OR COLOR.

FOR SOFTWARE USED TO CALCULATE OPTIMAL FILL LEVELS TO AVOID POTENTIAL UNDER FILL AND/OR OVER FILL, IN ANY MANUFACTURING PROCESS THAT REQUIRES OUTPUT TO BE PLACED IN ANOTHER CONTAINER AT AN IDEAL LEVEL (U.S. CLS. 21, 23, 26, 36 AND 38).

WENDY GOODMAN, EXAMINING ATTORNEY

CLASS 9—(Continued).

SN 85-267,088. THE PROCTER & GAMBLE COMPANY, CINCINNATI, OH. FILED 3-15-2011.

ACCUTARGET

THE MARK CONSISTS OF STANDARD CHARACTERS WITHOUT CLAIM TO ANY PARTICULAR FONT, STYLE, SIZE, OR COLOR.

FOR SOFTWARE USED TO CALCULATE OPTIMAL FILL LEVELS TO AVOID POTENTIAL UNDER FILL AND/OR OVER FILL, IN ANY MANUFACTURING PROCESS THAT REQUIRES OUTPUT TO BE PLACED IN ANOTHER CONTAINER AT AN IDEAL LEVEL (U.S. CLS. 21, 23, 26, 36 AND 38).

WENDY GOODMAN, EXAMINING ATTORNEY

SN 85-267,314. WEISS, MATTHEW, TA IGIFTI, ASHFORD, IRELAND, FILED 3-15-2011.

iGIFTi

THE MARK CONSISTS OF STANDARD CHARACTERS WITHOUT CLAIM TO ANY PARTICULAR FONT, STYLE, SIZE, OR COLOR.

FOR DOWNLOADABLE COMPUTER E-COMMERCE SOFTWARE TO ALLOW USERS TO PERFORM ELECTRONIC BUSINESS TRANSACTIONS PERTAINING TO THE PURCHASE OF GIFTS VIA A GLOBAL COMPUTER NETWORK (U.S. CLS. 21, 23, 26, 36 AND 38).

FIRST USE 2-27-2011; IN COMMERCE 3-15-2011.

KATHLEEN M. VANSTON, EXAMINING ATTORNEY

SN 85-267,366. CHEREDNICHENKO, STANISLAV, TAGANROG, RUSSIAN FED., FILED 3-15-2011.

RIXLER

THE MARK CONSISTS OF STANDARD CHARACTERS WITHOUT CLAIM TO ANY PARTICULAR FONT, STYLE, SIZE, OR COLOR.

FOR DOWNLOADABLE SOFTWARE FOR RECOVERING COMPUTER DATA, PASSWORDS, AND REMOVAL OF PASSWORDS, AND FOR ANALYZING ENCRYPTED AND PASSWORD PROTECTED FILES (U.S. CLS. 21, 23, 26, 36 AND 38).

FIRST USE 2-4-2003; IN COMMERCE 2-4-2003.

LESLIE RICHARDS, EXAMINING ATTORNEY

CLASS 9—(Continued).

SN 85-268,288. VERA'S HAIR SHOP BEAUTY SUPPLY LLC, WYNNE, AR. FILED 3-16-2011.

AWUOLLO HAIR

THE MARK CONSISTS OF STANDARD CHARACTERS WITHOUT CLAIM TO ANY PARTICULAR FONT, STYLE, SIZE, OR COLOR.

NO CLAIM IS MADE TO THE EXCLUSIVE RIGHT TO USE "HAIR", APART FROM THE MARK AS SHOWN.

THE WORDING "AWUOLLO" HAS NO MEANING IN A FOREIGN LANGUAGE.

FOR VENDING MACHINES (U.S. CLS. 21, 23, 26, 36 AND 38).

BRIAN PINO, EXAMINING ATTORNEY

SN 85-268,369. TOPAZ SYSTEMS, INC., SIMI VALLEY, CA. FILED 3-16-2011.

EMCEE

THE MARK CONSISTS OF STANDARD CHARACTERS WITHOUT CLAIM TO ANY PARTICULAR FONT, STYLE, SIZE, OR COLOR.

OWNER OF U.S. REG. NO. 3,699,632.

FOR COMPUTER SOFTWARE FOR ACQUISITION AND AUTHENTICATION OF USER INPUT IN AN ELECTRONIC TRANSACTION OR COMMUNICATION; COMPUTER SOFTWARE FOR ACQUISITION AND AUTHENTICATION AND ENCRYPTION OF USER INPUT; COMPUTER SOFTWARE FOR ACQUISITION AND AUTHENTICATION OF USER INPUT FOR USE IN PERSONAL COMPUTERS, COMPUTER NETWORKS, COMPUTER APPLICATIONS OR APPLICATIONS OVER THE INTERNET; COMPUTER SOFTWARE FOR ACQUISITION AND AUTHENTICATION OF USER INPUT, WHICH SOFTWARE CAN BE INTEGRATED INTO OTHER COMPUTER SOFTWARE APPLICATIONS (U.S. CLS. 21, 23, 26, 36 AND 38).

MICHAEL GAAFAR, EXAMINING ATTORNEY

SN 85-268,709. ABIONOVA US, LLC, ST. LOUIS PARK, MN. FILED 3-16-2011.

NOVAREG

THE MARK CONSISTS OF STANDARD CHARACTERS WITHOUT CLAIM TO ANY PARTICULAR FONT, STYLE, SIZE, OR COLOR.

FOR CONTROL AND MONITORING UNIT FOR HEATING SYSTEM (U.S. CLS. 21, 23, 26, 36 AND 38).

ALLISON SCHRODY, EXAMINING ATTORNEY

CLASS 9—(Continued).

SN 85-268,712. HERAEUS ELECTRO-NITE INTERNATIONAL N.V., HOUTHALEN, BELGIUM, FILED 3-16-2011.

CELOX PLUS

THE MARK CONSISTS OF STANDARD CHARACTERS WITHOUT CLAIM TO ANY PARTICULAR FONT, STYLE, SIZE, OR COLOR.

OWNER OF U.S. REG. NOS. 995,270 AND 2,087,211.

FOR OXYGEN SENSOR SYSTEM, NAMELY, A DEVICE FOR DETERMINING TEMPERATURE AND ACTIVE OXYGEN LEVELS IN MOLTEN METALS INCLUDING A PROBE FOR IMMERSION INTO A BATH OF MOLTEN METAL, A HOLDER FOR SUPPORTING THE PROBE, A RECORDER FOR DISPLAYING OR RECORDING READINGS OF THE PROBE, AND A SOLID METALLURGICAL SAMPLE (U.S. CLS. 21, 23, 26, 36 AND 38).

FIRST USE 2-28-2011; IN COMMERCE 2-28-2011.
ALLISON SCHRODY, EXAMINING ATTORNEY

CLASS 9—(Continued).

SN 85-268,959. VW SYSTEMS LTD., WAN CHAI, HONG KONG, FILED 3-16-2011.

WYTRON

THE MARK CONSISTS OF STANDARD CHARACTERS WITHOUT CLAIM TO ANY PARTICULAR FONT, STYLE, SIZE, OR COLOR.

FOR ELECTRIC CONTROLLERS, NAMELY, DUPLICATOR CONTROLLER FOR DIGITAL STORAGE MEDIA; APPARATUS FOR REPRODUCTION OF SOUND, IMAGES, AND DATA, NAMELY, MANUAL DUPLICATOR TOWERS FOR RECORDING SOUND, IMAGES, AND DATA ONTO DIGITAL STORAGE MEDIA (U.S. CLS. 21, 23, 26, 36 AND 38).

FIRST USE 12-14-2010; IN COMMERCE 12-14-2010.
NICHOLAS COLEMAN, EXAMINING ATTORNEY

SN 85-269,383. BEAVER CREEK CONSULTING CORP, RESTON, VA. FILED 3-17-2011.

Contacts Cleaner

THE MARK CONSISTS OF STANDARD CHARACTERS WITHOUT CLAIM TO ANY PARTICULAR FONT, STYLE, SIZE, OR COLOR.

NO CLAIM IS MADE TO THE EXCLUSIVE RIGHT TO USE "CONTACTS", APART FROM THE MARK AS SHOWN.

FOR COMPUTER APPLICATION SOFTWARE FOR MOBILE PHONES, NAMELY, SOFTWARE FOR REMOVAL OF DUPLICATE CONTACTS FROM A MOBILE PHONE'S ADDRESS BOOK USED TO IDENTIFY DUPLICATE CONTACTS, MERGE THE CONTACT ATTRIBUTES, EMAIL ADDRESSES AND PHONES NUMBERS INTO ONE CONTACT AND THEN REMOVES THE DUPLICATE CONTACTS FROM THE ADDRESS BOOK (U.S. CLS. 21, 23, 26, 36 AND 38).

FIRST USE 11-1-2010; IN COMMERCE 11-1-2010.
FLORENTINA BLANDU, EXAMINING ATTORNEY

SN 85-268,949. VINPOWER INC., ALHAMBRA, CA. FILED 3-16-2011.

VINPOWER DIGITAL

THE MARK CONSISTS OF STANDARD CHARACTERS WITHOUT CLAIM TO ANY PARTICULAR FONT, STYLE, SIZE, OR COLOR.

NO CLAIM IS MADE TO THE EXCLUSIVE RIGHT TO USE "DIGITAL", APART FROM THE MARK AS SHOWN.

FOR PRINTED CIRCUIT BOARDS; ELECTRONIC CONTROLLERS FOR DIGITAL STORAGE MEDIA DUPLICATORS; MANUAL DIGITAL STORAGE MEDIA DUPLICATORS IN THE NATURE OF TOWERS, NAMELY, DIGITAL MEDIA BURNERS AND SIMILAR DEVICES FOR THE DUPLICATION OF ALL TYPES OF DIGITAL STORAGE MEDIA, INCLUDING HARD DRIVES, FLASH DRIVES, AND FLASH MEMORY CARDS, THAT REQUIRE USER INTERVENTION; AUTOMATED DIGITAL STORAGE MEDIA DUPLICATORS, NAMELY, DIGITAL MEDIA BURNERS AND SIMILAR DEVICES FOR THE DUPLICATION OF ALL TYPES OF DIGITAL STORAGE MEDIA, INCLUDING HARD DRIVES, FLASH DRIVES, AND FLASH MEMORY CARDS, THAT DO NOT REQUIRE USER INTERVENTION; COMPUTER HARDWARE AND COMPUTER PERIPHERAL DEVICES; COMPUTER OPERATING SOFTWARE (U.S. CLS. 21, 23, 26, 36 AND 38).

FIRST USE 1-0-2005; IN COMMERCE 1-0-2005.
KIM MONINGHOFF, EXAMINING ATTORNEY

SN 85-269,408. L-COM, INC., NORTH ANDOVER, MA. FILED 3-17-2011.

HYPERGAIN

THE MARK CONSISTS OF STANDARD CHARACTERS WITHOUT CLAIM TO ANY PARTICULAR FONT, STYLE, SIZE, OR COLOR.

OWNER OF U.S. REG. NO. 2,430,792.

FOR ANTENNAS (U.S. CLS. 21, 23, 26, 36 AND 38).
FIRST USE 9-1-1993; IN COMMERCE 9-1-1993.
LINDSEY RUBIN, EXAMINING ATTORNEY

CLASS 9—(Continued).

SN 85-269,412. MICROELECTRONICS RESEARCH AND DEVELOPMENT CORPORATION, COLORADO SPRINGS, CO. FILED 3-17-2011.

TEMPORAL LATCH

THE MARK CONSISTS OF STANDARD CHARACTERS WITHOUT CLAIM TO ANY PARTICULAR FONT, STYLE, SIZE, OR COLOR.

NO CLAIM IS MADE TO THE EXCLUSIVE RIGHT TO USE "LATCH", APART FROM THE MARK AS SHOWN.

FOR DIODES; APPLICATION SPECIFIC INTEGRATED CIRCUITS; ELECTRONIC INTEGRATED CIRCUITS; RADIATION-HARDENED INTEGRATED CIRCUITS; METAL OXIDE SEMICONDUCTOR FIELD EFFECT TRANSISTORS; ELECTRONIC INTEGRATED CIRCUITS PROVIDING RADIATION HARDENING FOR DIGITAL LOGIC ARCHITECTURE; ELECTRONIC CIRCUIT BOARD COMPONENT PARTS PROVIDING RADIATION HARDENING FOR DIGITAL LOGIC ARCHITECTURE (U.S. CLS. 21, 23, 26, 36 AND 38).

SOPHIA S. KIM, EXAMINING ATTORNEY

SN 85-269,489. SMARTRONIX, INC., HOLLYWOOD, MD. FILED 3-17-2011.

NRG

THE MARK CONSISTS OF STANDARD CHARACTERS WITHOUT CLAIM TO ANY PARTICULAR FONT, STYLE, SIZE, OR COLOR.

FOR NETWORK RADIO GATEWAY APPLIANCE AND SOFTWARE SUPPORTING RADIO OVER INTERNET PROTOCOL (ROIP) FOR SPECIALIZED GOVERNMENT USE; INTEROPERABLE COMMUNICATION APPLIANCE AND SOFTWARE DESIGNED TO PROVIDE AUDIO, STREAMING VIDEO AND DATA, VOIP PHONE, AND ACCESS TO INTERNET PROTOCOL (IP) DEVICES SUCH AS ROUTERS, SWITCHES, AND OTHER NETWORK GATEWAY DEVICES THAT ENHANCE NETWORK COMMUNICATIONS INTEROPERABILITY (U.S. CLS. 21, 23, 26, 36 AND 38).

DORITT L. CARROLL, EXAMINING ATTORNEY

CLASS 9—(Continued).

SN 85-270,538. STRUCTURAL INTEGRITY TECHNOLOGIES INC., MARKHAM, ONTARIO, CANADA, FILED 3-18-2011.

ULTRAMARS

THE MARK CONSISTS OF STANDARD CHARACTERS WITHOUT CLAIM TO ANY PARTICULAR FONT, STYLE, SIZE, OR COLOR.

FOR MATERIAL TESTING INSTRUMENTS AND MACHINES, NAMELY, INSTRUMENTS AND MACHINES FOR MEASURING RESIDUAL AND APPLIED STRESS IN MATERIALS AND WELDED STRUCTURES (U.S. CLS. 21, 23, 26, 36 AND 38).

KRISTINA MORRIS, EXAMINING ATTORNEY

SN 85-270,588. ZOHO CORPORATION, PLEASANTON, CA. FILED 3-18-2011.

ADManager Plus

THE MARK CONSISTS OF STANDARD CHARACTERS WITHOUT CLAIM TO ANY PARTICULAR FONT, STYLE, SIZE, OR COLOR.

NO CLAIM IS MADE TO THE EXCLUSIVE RIGHT TO USE "AD MANAGER", APART FROM THE MARK AS SHOWN.

FOR COMPUTER SOFTWARE FOR INFORMATION TECHNOLOGY COMPLIANCE, ACTIVE DIRECTORY ADMINISTRATION, REPORTING, AND HELPDESK DELEGATION (U.S. CLS. 21, 23, 26, 36 AND 38).

FIRST USE 4-3-2006; IN COMMERCE 4-22-2006.

H. M. FISHER, EXAMINING ATTORNEY

SN 85-272,023. WEATHERFORD/LAMB, INC., HOUSTON, TX. FILED 3-21-2011.

SeaHawk

THE MARK CONSISTS OF STANDARD CHARACTERS WITHOUT CLAIM TO ANY PARTICULAR FONT, STYLE, SIZE, OR COLOR.

FOR CAMERAS, VIDEO CAMERAS, COMPUTER HARDWARE AND SOFTWARE FOR RELAYING, ANALYZING AND COMPILING DATA FROM SUBSEA SURVEILLANCE EQUIPMENT IN THE OIL AND GAS INDUSTRY (U.S. CLS. 21, 23, 26, 36 AND 38).

FIRST USE 2-24-2011; IN COMMERCE 2-24-2011.

MATTHEW MCDOWELL, EXAMINING ATTORNEY

CLASS 9—(Continued).

SN 85-272,070. ZOH0 CORPORATION, FORMERLY ADVENTNET, INC., PLEASANTON, CA. FILED 3-21-2011.

ServiceDesk Plus

THE MARK CONSISTS OF STANDARD CHARACTERS WITHOUT CLAIM TO ANY PARTICULAR FONT, STYLE, SIZE, OR COLOR.

NO CLAIM IS MADE TO THE EXCLUSIVE RIGHT TO USE "SERVICE DESK", APART FROM THE MARK AS SHOWN.

FOR COMPUTER SOFTWARE FOR USE IN THE FIELD OF HELP DESK AND ASSET MANAGEMENT (U.S. CLS. 21, 23, 26, 36 AND 38).

FIRST USE 3-7-2005; IN COMMERCE 3-7-2005.
H. M. FISHER, EXAMINING ATTORNEY

SN 85-272,387. MYSTERY STREET RECORDS, LLC, SANTA MONICA, CA. FILED 3-21-2011.

Mystery Street Records

THE MARK CONSISTS OF STANDARD CHARACTERS WITHOUT CLAIM TO ANY PARTICULAR FONT, STYLE, SIZE, OR COLOR.

NO CLAIM IS MADE TO THE EXCLUSIVE RIGHT TO USE "RECORDS", APART FROM THE MARK AS SHOWN.

FOR MUSICAL SOUND RECORDINGS AND AUDIO-VISUAL RECORDINGS FEATURING MUSIC (U.S. CLS. 21, 23, 26, 36 AND 38).

FIRST USE 10-30-2009; IN COMMERCE 1-0-2011.
REGINA DRUMMOND, EXAMINING ATTORNEY

SN 85-273,177. GIBBS-NOLEN JV, MIDLAND, TX. FILED 3-22-2011.

GREENSHOT

THE MARK CONSISTS OF STANDARD CHARACTERS WITHOUT CLAIM TO ANY PARTICULAR FONT, STYLE, SIZE, OR COLOR.

FOR OIL AND GAS WELL DOWNHOLE SURVEY AND MEASUREMENT EQUIPMENT (U.S. CLS. 21, 23, 26, 36 AND 38).

GILBERT SWIFT, EXAMINING ATTORNEY

CLASS 9—(Continued).

SN 85-273,240. TDI INTERNATIONAL, INC., TUCSON, AZ. FILED 3-22-2011.

Nitro-Save

THE MARK CONSISTS OF STANDARD CHARACTERS WITHOUT CLAIM TO ANY PARTICULAR FONT, STYLE, SIZE, OR COLOR.

FOR ELECTRIC HUMIDITY CONTROL MONITOR USED FOR PRE-SETTING RELATIVE HUMIDITY WHICH HAS THE ANCILLARY RESULT OF REDUCING NITROGEN CONSUMPTION BECAUSE OF THE PRE-SETTING AND CONTROLLING OF THE RELATIVE HUMIDITY VIA THE MONITOR (U.S. CLS. 21, 23, 26, 36 AND 38).

FIRST USE 8-25-2003; IN COMMERCE 8-25-2003.
BRENDAN MCCAULEY, EXAMINING ATTORNEY

SN 85-273,246. INNOVATIVE TIMING SYSTEMS, LLC, ST. LOUIS, MO. FILED 3-22-2011.

CHEETAH

THE MARK CONSISTS OF STANDARD CHARACTERS WITHOUT CLAIM TO ANY PARTICULAR FONT, STYLE, SIZE, OR COLOR.

FOR TIMING SYSTEMS, NAMELY, COMPUTER SYSTEMS, SOFTWARE, TRANSCIEVERS, AND RFID TRANSCIEVER CHIPS FOR IDENTIFYING AND TRACKING EVENT OR RACE PARTICIPANTS AND OBJECTS HAVING TIMING SENSORS ASSOCIATED THEREWITH AND DETERMINING TIMES, MOVEMENT AND LOCATIONS OF INDIVIDUAL PARTICIPANTS OR OBJECTS, FOR ALL RACING INCLUDING HIGH SPEED CRITERIUMS, MOTORCYCLE, KAYAK, CYCLING, AUTOMOTIVE AND HORSE RACING (U.S. CLS. 21, 23, 26, 36 AND 38).

CHRISTINE COOPER, EXAMINING ATTORNEY

CLASS 9—(Continued).

SN 85-273,585. VILLAIN LLC, CARY, NC. FILED 3-22-2011.

MATCHLINGS

THE MARK CONSISTS OF STANDARD CHARACTERS WITHOUT CLAIM TO ANY PARTICULAR FONT, STYLE, SIZE, OR COLOR.

FOR DOWNLOADABLE ELECTRONIC GAME PROGRAMS; DOWNLOADABLE SOFTWARE FOR VIDEO GAMES USED ON ANY COMPUTERIZED PLATFORM, NAMELY, HAND-HELD ELECTRONIC DEVICES, ELECTRONIC ENTERTAINMENT DEVICES, TELECOMMUNICATIONS DEVICES, MOBILE PHONES, AND ELECTRONIC COMMUNICATION DEVICES; ELECTRONIC GAME SOFTWARE; ELECTRONIC GAME SOFTWARE FOR CELLULAR TELEPHONES; ELECTRONIC GAME SOFTWARE FOR HANDHELD ELECTRONIC DEVICES; ELECTRONIC GAME SOFTWARE FOR WIRELESS DEVICES; INTERACTIVE GAME PROGRAMS; INTERACTIVE GAME SOFTWARE (U.S. CLS. 21, 23, 26, 36 AND 38).

JESSICA A. POWERS, EXAMINING ATTORNEY

SN 85-273,673. STRICKLAND, KENNETH DREW, ALPHARETTA, GA. FILED 3-22-2011.

FlashRight

THE MARK CONSISTS OF STANDARD CHARACTERS WITHOUT CLAIM TO ANY PARTICULAR FONT, STYLE, SIZE, OR COLOR.

OWNER OF U.S. REG. NO. 3,649,495.

FOR COLLAPSIBLE LIGHT DIRECTORS AND DIFFUSERS FOR USE WITH PHOTOGRAPHIC LIGHTING EQUIPMENT FOR PROFESSIONAL AND HIGH-END PHOTOGRAPHY (U.S. CLS. 21, 23, 26, 36 AND 38).

SIMON TENG, EXAMINING ATTORNEY

CLASS 9—(Continued).

SN 85-273,701. TAM NETWORKS, INC., SAN RAMON, CA. FILED 3-22-2011.

TAM NETWORKS

THE MARK CONSISTS OF STANDARD CHARACTERS WITHOUT CLAIM TO ANY PARTICULAR FONT, STYLE, SIZE, OR COLOR.

NO CLAIM IS MADE TO THE EXCLUSIVE RIGHT TO USE "NETWORKS", APART FROM THE MARK AS SHOWN.

FOR COMPUTER NETWORKING EQUIPMENT, NAMELY, COMPUTER HARDWARE FOR INTERCONNECTING, MANAGING, AND OPERATING LOCAL AND WIDE AREA NETWORKS, COMPUTER SYSTEMS, ETHERNET NETWORKING EQUIPMENT, ROUTERS, AND SWITCHES (U.S. CLS. 21, 23, 26, 36 AND 38).

FIRST USE 1-10-2011; IN COMMERCE 1-10-2011.

MORGAN WYNNE, EXAMINING ATTORNEY

SN 85-273,726. HYTRUST, INC., MOUNTAIN VIEW, CA. FILED 3-22-2011.

HYTRUST CLOUD CONTROL

THE MARK CONSISTS OF STANDARD CHARACTERS WITHOUT CLAIM TO ANY PARTICULAR FONT, STYLE, SIZE, OR COLOR.

OWNER OF U.S. REG. NO. 3,719,721.

NO CLAIM IS MADE TO THE EXCLUSIVE RIGHT TO USE "CLOUD CONTROL", APART FROM THE MARK AS SHOWN.

FOR COMPUTER SOFTWARE FOR USE IN PROVIDING SECURITY OF VIRTUAL INFRASTRUCTURE PLATFORM SOFTWARE (U.S. CLS. 21, 23, 26, 36 AND 38).

JAMES MACFARLANE, EXAMINING ATTORNEY

SN 85-273,792. BUILDINGREPORTS.COM, INC., SUWANEE, GA. FILED 3-22-2011.

BRForms

THE MARK CONSISTS OF STANDARD CHARACTERS WITHOUT CLAIM TO ANY PARTICULAR FONT, STYLE, SIZE, OR COLOR.

FOR COMPUTER SOFTWARE FOR CONVERTING PAPER FORMS INTO DIGITAL DOCUMENTS AND MANAGING DIGITAL DOCUMENTS ONLINE THAT MAY BE DOWNLOADED FROM A GLOBAL COMPUTER NETWORK (U.S. CLS. 21, 23, 26, 36 AND 38).

FIRST USE 5-19-2011; IN COMMERCE 5-19-2011.

MATTHEW MCDOWELL, EXAMINING ATTORNEY

CLASS 9—(Continued).

SN 85-274,070. GRIFFIN TECHNOLOGY, INC., NASHVILLE, TN. FILED 3-23-2011.

QSCRIPT

THE MARK CONSISTS OF STANDARD CHARACTERS WITHOUT CLAIM TO ANY PARTICULAR FONT, STYLE, SIZE, OR COLOR.

FOR OPERATING SOFTWARE FOR AN OFF-CAMERA DEVICE THAT DISPLAYS A MAGNIFIED SCRIPT SO THAT IT IS VISIBLE TO PERFORMERS OR SPEAKERS (U.S. CLS. 21, 23, 26, 36 AND 38).

TRACY WHITTAKER-BROWN, EXAMINING ATTORNEY

CLASS 9—(Continued).

SN 85-274,287. DYNAMIC VOICE DATA, INC., STAFFORD, TX. FILED 3-23-2011.

DYNACABLE

THE MARK CONSISTS OF STANDARD CHARACTERS WITHOUT CLAIM TO ANY PARTICULAR FONT, STYLE, SIZE, OR COLOR.

FOR CABLES AND FIBERS FOR THE TRANSMISSION OF SOUNDS, IMAGES, AND DATA; CABLES FOR COMPUTER APPLICATIONS; CONNECTION CABLES; ETHERNET CABLES; METAL DATA CABINETS SPECIALLY ADAPTED TO PROTECT TELECOMMUNICATIONS EQUIPMENT IN THE NATURE OF FIBER OPTIC CABLES; CONNECTING DEVICES FOR COMPUTER AND TELECOMMUNICATIONS EQUIPMENT, NAMELY, WIRE MANAGERS, PATCH PANELS FOR HOUSING ELECTRICAL CONNECTORS, KEYSTONE JACKS, FACEPLATES FOR USE IN CABLE AND WIRING, SURFACE MOUNT BOXES, PATCH CORDS, WALL MOUNTED RACKS FOR CABLE AND WIRING, CROSS CONNECT WIRES, AND PUNCH DOWN BLOCKS AND BRACKETS (U.S. CLS. 21, 23, 26, 36 AND 38).

MARK PILARO, EXAMINING ATTORNEY

SN 85-274,269. NEWGISTICS, INC., AUSTIN, TX. FILED 3-23-2011.

FLEXSHIP BY NEWGISTICS

THE MARK CONSISTS OF STANDARD CHARACTERS WITHOUT CLAIM TO ANY PARTICULAR FONT, STYLE, SIZE, OR COLOR.

OWNER OF U.S. REG. NOS. 2,776,146 AND 3,766,924.
FOR COMPUTER SOFTWARE FOR PREPARING, ADMINISTERING, AND MANAGING THE SHIPMENT AND RETURN OF MERCHANDISE PARCELS AND PACKAGES, FOR PRODUCING AND PRINTING SHIPMENT MANIFESTS AND LABELS FOR THE SHIPMENT AND RETURN OF MERCHANDISE PARCELS AND PACKAGES, AND FOR DATA PROCESSING, REPORTING, AND BILLING IN THE FIELD OF SHIPPING AND RETURNING MERCHANDISE PARCELS AND PACKAGES (U.S. CLS. 21, 23, 26, 36 AND 38).

REBECCA GILBERT, EXAMINING ATTORNEY

SN 85-274,934. VIRTUALDEMAND COM DE MEXICO S.A. DE C.V., VALLEJO, AZCAPOTZALCO, MEXICO, FILED 3-23-2011.

SWISSALPS

THE MARK CONSISTS OF THE WORD "SWISSALPS" WITH A HORIZONTAL BRACKET DESIGN TO THE LEFT.

FOR CARRYING CASES FOR ELECTRONIC EQUIPMENT, NAMELY, COMPUTERS AND CELL PHONES; CARRYING CASES FOR MOBILE COMPUTERS; CASES FOR MUSIC, AUDIO AND RELATED ELECTRONIC EQUIPMENT, NAMELY, CASES FOR AUDIO TUNERS, AUDIO RECEIVERS, AMPLIFIERS, TAPE PLAYERS, COMPACT DISC PLAYERS, MP3 CONTROLLERS/PLAYERS, AUDIO MIXERS, AUDIO SPEAKERS IN THE NATURE OF MUSIC STUDIO MONITORS, MICROPHONES, AUDIO SPEAKERS, COMPACT DISCS, AUDIO TAPES, PORTABLE COMPUTERS, ANTENNAS, PHONOGRAPHIC RECORD PLAYERS, AUDIO RECORDING EQUIPMENT, AND THE CABLES ASSOCIATED WITH ALL OF THE FOREGOING EQUIPMENT; COMPUTER CARRYING CASES; NOTEBOOK COMPUTER CARRYING CASES; ROLLING CASES ESPECIALLY ADAPTED FOR HOLDING LAPTOPS AND NOTEBOOK COMPUTERS (U.S. CLS. 21, 23, 26, 36 AND 38).

ROBIN MITTLER, EXAMINING ATTORNEY

CLASS 9—(Continued).

SN 85-274,979. AUTOMATION, INC., DBA PCAMERICA, PEARL RIVER, NY. FILED 3-23-2011.

Cash Register Express

THE MARK CONSISTS OF STANDARD CHARACTERS WITHOUT CLAIM TO ANY PARTICULAR FONT, STYLE, SIZE, OR COLOR.

NO CLAIM IS MADE TO THE EXCLUSIVE RIGHT TO USE "CASH REGISTER", APART FROM THE MARK AS SHOWN.

SEC. 2(F).

FOR ELECTRONIC EQUIPMENT FOR POINT-OF-SALES (POS) SYSTEMS, NAMELY, POINT-OF-SALE TERMINALS, BAR CODE READERS, OPTICAL READERS, ADVERTISEMENT DISPLAY MONITORS, KEYBOARDS, PRINTERS, SCANNERS, RADIO TRANSMITTERS, RADIO RECEIVERS, COMPUTER HARDWARE, AND COMPUTER OPERATING SOFTWARE (U.S. CLS. 21, 23, 26, 36 AND 38).

FIRST USE 9-15-1989; IN COMMERCE 9-15-1989.

SUSAN RICHARDS, EXAMINING ATTORNEY

CLASS 9—(Continued).

SN 85-275,499. PULSE-ROBOTICS, INC., EAGLE, ID. FILED 3-24-2011.

Symbeeco

THE MARK CONSISTS OF STANDARD CHARACTERS WITHOUT CLAIM TO ANY PARTICULAR FONT, STYLE, SIZE, OR COLOR.

FOR COMPUTER APPLICATION SOFTWARE FOR MOBILE PHONES, MOBILE MEDIA PLAYERS AND ROBOTIC DOCKS, NAMELY, SOFTWARE FOR TELEPRESENCE, AUTOMATED PHOTOGRAPHY, PHOTO SURVEILLANCE SECURITY, EXERCISE PROGRAMS, AND EDUCATION (U.S. CLS. 21, 23, 26, 36 AND 38).

SEAN CROWLEY, EXAMINING ATTORNEY

SN 85-275,679. BANOM, INC., WAYNE, PA. FILED 3-24-2011.

TRACKPRO

THE MARK CONSISTS OF STANDARD CHARACTERS WITHOUT CLAIM TO ANY PARTICULAR FONT, STYLE, SIZE, OR COLOR.

FOR VENDING MACHINES FOR DISPENSING AND COLLECTING INDUSTRIAL GLOVES (U.S. CLS. 21, 23, 26, 36 AND 38).

PAUL F. GAST, EXAMINING ATTORNEY

SN 85-275,908. THEMIS, FREMONT, CA. FILED 3-24-2011.

NANOPACK

THE MARK CONSISTS OF STANDARD CHARACTERS WITHOUT CLAIM TO ANY PARTICULAR FONT, STYLE, SIZE, OR COLOR.

FOR COMPUTER HARDWARE CASE HAVING A THERMAL AND KINETIC MANAGEMENT SYSTEM COMPRISED OF A ROBUST, SEALED AND CONDUCTION COOLED ENVIRONMENT FOR INTERCHANGEABLE ELECTRONICS MODULES, WITHIN THE ENCLOSURE, AND AN EXTERNAL HEAT EXCHANGER AND INPUT-OUTPUT CONNECTOR PANEL, COMBINED IN A SINGLE, SMALL PACKAGE (U.S. CLS. 21, 23, 26, 36 AND 38).

MAYUR VAGHANI, EXAMINING ATTORNEY

SN 85-275,129. RPK TECHNICAL, LTD., MATTHEWS, NC. FILED 3-23-2011.

DIRIGO

THE MARK CONSISTS OF STANDARD CHARACTERS WITHOUT CLAIM TO ANY PARTICULAR FONT, STYLE, SIZE, OR COLOR.

"DIRIGO" MEANS "I DIRECT" OR "I LEAD" IN ENGLISH.

FOR PORTABLE DIGITAL AUDIO AND VIDEO PLAYERS AND RECORDERS (U.S. CLS. 21, 23, 26, 36 AND 38).

IRA J. GOODSID, EXAMINING ATTORNEY

SN 85-275,238. LONGMORE, LANCE, MERRIAM, KS. FILED 3-24-2011.

ROADMAP PLANNER

THE MARK CONSISTS OF STANDARD CHARACTERS WITHOUT CLAIM TO ANY PARTICULAR FONT, STYLE, SIZE, OR COLOR.

NO CLAIM IS MADE TO THE EXCLUSIVE RIGHT TO USE "PLANNER", APART FROM THE MARK AS SHOWN.

FOR ELECTRONIC DAY PLANNERS (U.S. CLS. 21, 23, 26, 36 AND 38).

FIRST USE 3-1-1999; IN COMMERCE 3-1-2008.

CHRISTINE COOPER, EXAMINING ATTORNEY

CLASS 9—(Continued).

SN 85-275,994. CINCOM SYSTEMS, INC., CINCINNATI, OH.
FILED 3-24-2011.

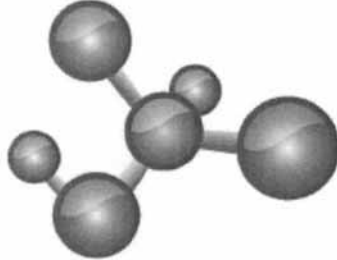

THE MARK CONSISTS OF SIX "BALLS" CONNECTED IN AN ATOMIC DESIGN.
FOR COMPUTER SOFTWARE FOR COMPUTER APPLICATIONS DESIGN, COMPUTER APPLICATIONS DEVELOPMENT AND COMPUTER APPLICATIONS SUPPORT (U.S. CLS. 21, 23, 26, 36 AND 38).
FIRST USE 10-17-2008; IN COMMERCE 10-17-2008.
ANDREW RHIM, EXAMINING ATTORNEY

SN 85-276,078. LANG-MEKRA NORTH AMERICA, LLC,
RIDGWAY, SC. FILED 3-24-2011.

IDEALVIEW

THE MARK CONSISTS OF STANDARD CHARACTERS WITHOUT CLAIM TO ANY PARTICULAR FONT, STYLE, SIZE, OR COLOR.
FOR VEHICLE VISION SYSTEMS COMPRISING SENSORS, CAMERAS, MONITORS AND MIRROR ASSEMBLIES, FOR OBSERVING AREAS ADJACENT THE VEHICLE (U.S. CLS. 21, 23, 26, 36 AND 38).
RUDY R. SINGLETON, EXAMINING ATTORNEY

SN 85-276,114. LEDDER HIGH RISK VENTURE CAPITAL,
L.P., L.L.L.P., FREDERICKSBURG, TX. FILED 3-24-2011.

MY STASH

THE MARK CONSISTS OF STANDARD CHARACTERS WITHOUT CLAIM TO ANY PARTICULAR FONT, STYLE, SIZE, OR COLOR.
FOR FINANCIAL SOFTWARE FOR ALLOWING USERS TO ACCUMULATE MONEY USING ONLINE SERVICES, MOBILE APPLICATIONS OR COMBINATIONS THEREOF (U.S. CLS. 21, 23, 26, 36 AND 38).
H. M. FISHER, EXAMINING ATTORNEY

CLASS 9—(Continued).

SN 85-276,115. RONALD J. BARRETT, BUFFALO, NY.
FILED 3-24-2011.

**SMOKE SIGNAL THE SIGN of
LIFE**

THE MARK CONSISTS OF STANDARD CHARACTERS WITHOUT CLAIM TO ANY PARTICULAR FONT, STYLE, SIZE, OR COLOR.
FOR FIRE ALARM AND EMERGENCY EVACUATION DEVICES, NAMELY, FIRE ALARM CONTROL PANELS, SMOKE DETECTORS, HEAT DETECTORS, ALARM PULL STATIONS, AUDIBLE AND VISIBLE NOTIFICATION APPLIANCES, STROBES, SIRENS, BELLS, HORNS, AND SPEAKERS; MECHANICAL SIGNS; LUMINOUS FIRE SAFETY AND FIRE RESCUE SIGNS (U.S. CLS. 21, 23, 26, 36 AND 38).
H. M. FISHER, EXAMINING ATTORNEY

SN 85-276,119. BDSRCO, INC., WILMINGTON, DE. FILED 3-24-2011.

REEL LEGENDS

THE MARK CONSISTS OF STANDARD CHARACTERS WITHOUT CLAIM TO ANY PARTICULAR FONT, STYLE, SIZE, OR COLOR.
OWNER OF U.S. REG. NO. 2,755,158.
FOR SUNGLASSES (U.S. CLS. 21, 23, 26, 36 AND 38).
MATTHEW MCDOWELL, EXAMINING ATTORNEY

SN 85-276,208. EMERSON CLIMATE TECHNOLOGIES, INC.,
SIDNEY, OH. FILED 3-24-2011.

COPELAND E-SAVER

THE MARK CONSISTS OF STANDARD CHARACTERS WITHOUT CLAIM TO ANY PARTICULAR FONT, STYLE, SIZE, OR COLOR.
OWNER OF U.S. REG. NOS. 890,471, 3,697,065 AND OTHERS.
FOR COMPUTER APPLICATION SOFTWARE FOR MOBILE PHONES AND FOR SMARTPHONES, NAMELY, COMPUTER SOFTWARE FOR USE IN CALCULATING EFFICIENCY AND ENERGY COST SAVINGS OF HEAT PUMP, HVAC AND REFRIGERATION SYSTEMS; DOWNLOADABLE SOFTWARE IN THE NATURE OF A MOBILE APPLICATION FOR USE IN CALCULATING EFFICIENCY AND ENERGY COST SAVINGS OF HEAT PUMP, HVAC AND REFRIGERATION SYSTEMS (U.S. CLS. 21, 23, 26, 36 AND 38).
MICHAEL TANNER, EXAMINING ATTORNEY

CLASS 9—(Continued).

SN 85-276,222. EMERSON CLIMATE TECHNOLOGIES, INC.,
SIDNEY, OH. FILED 3-24-2011.

COPELAND X-REF

THE MARK CONSISTS OF STANDARD CHARACTERS
WITHOUT CLAIM TO ANY PARTICULAR FONT, STYLE,
SIZE, OR COLOR.

OWNER OF U.S. REG. NOS. 890,471, 3,697,065 AND
OTHERS.

FOR COMPUTER APPLICATION SOFTWARE FOR
MOBILE PHONES AND FOR SMARTPHONES,
NAMELY, COMPUTER SOFTWARE FOR USE IN CROSS
REFERENCING COMPRESSOR MODEL INFORMA-
TION; DOWNLOADABLE SOFTWARE IN THE NATURE
OF A MOBILE APPLICATION FOR USE IN CROSS
REFERENCING COMPRESSOR MODEL INFORMATION
(U.S. CLS. 21, 23, 26, 36 AND 38).

MICHAEL TANNER, EXAMINING ATTORNEY

SN 85-276,429. GRAND VISION GAMING, LLC, BILLINGS,
MT. FILED 3-24-2011.

ULTRA 8'S

THE MARK CONSISTS OF STANDARD CHARACTERS
WITHOUT CLAIM TO ANY PARTICULAR FONT, STYLE,
SIZE, OR COLOR.

NO CLAIM IS MADE TO THE EXCLUSIVE RIGHT TO
USE "8'S", APART FROM THE MARK AS SHOWN.

FOR GAMING MACHINES (U.S. CLS. 21, 23, 26, 36
AND 38).

DAVID H. STINE, EXAMINING ATTORNEY

SN 85-276,526. DAY-TIMERS, INC., EAST TEXAS, PA. FILED
3-25-2011.

HOMELIFE

THE MARK CONSISTS OF STANDARD CHARACTERS
WITHOUT CLAIM TO ANY PARTICULAR FONT, STYLE,
SIZE, OR COLOR.

FOR COMPUTER SOFTWARE AND MULTIMEDIA
SOFTWARE FOR USE IN STORING AND MANAGING
HOUSEHOLD, FAMILY, BUSINESS, OR PERSONAL
INFORMATION; FOR SCHEDULING AND CALENDAR-
ING; AND FOR FINANCE AND ACCOUNTING PUR-
POSES (U.S. CLS. 21, 23, 26, 36 AND 38).

ALICE BENMAMAN, EXAMINING ATTORNEY

CLASS 9—(Continued).

SN 85-276,570. UMAREX SPORTWAFFEN GMBH & CO. KG,
ARNSBERG, FED REP GERMANY, FILED 3-25-2011.

UMAREX USA

THE MARK CONSISTS OF STANDARD CHARACTERS
WITHOUT CLAIM TO ANY PARTICULAR FONT, STYLE,
SIZE, OR COLOR.

OWNER OF U.S. REG. NO. 2,608,464.

NO CLAIM IS MADE TO THE EXCLUSIVE RIGHT TO
USE "USA", APART FROM THE MARK AS SHOWN.

FOR TACTICAL LASER SIGHTS; SPOTTING SCOPES
(U.S. CLS. 21, 23, 26, 36 AND 38).

FIRST USE 3-0-2007; IN COMMERCE 3-0-2007.

MORGAN WYNNE, EXAMINING ATTORNEY

SN 85-276,611. PEERLESS INDUSTRIES, INC., AURORA, IL.
FILED 3-25-2011.

PEERLESS AV FOXY CANS

THE MARK CONSISTS OF STANDARD CHARACTERS
WITHOUT CLAIM TO ANY PARTICULAR FONT, STYLE,
SIZE, OR COLOR.

OWNER OF U.S. REG. NOS. 1,662,187 AND 3,648,907.

NO CLAIM IS MADE TO THE EXCLUSIVE RIGHT TO
USE "AV" OR "CANS", APART FROM THE MARK AS
SHOWN.

FOR HEADPHONES (U.S. CLS. 21, 23, 26, 36 AND 38).

MATTHEW MCDOWELL, EXAMINING ATTORNEY

SN 85-276,983. JUNIPER SYSTEMS, INC., LOGAN, UT.
FILED 3-25-2011.

MESA

THE MARK CONSISTS OF STANDARD CHARACTERS
WITHOUT CLAIM TO ANY PARTICULAR FONT, STYLE,
SIZE, OR COLOR.

FOR COMPUTERS; COMPUTER HARDWARE AND
PERIPHERAL DEVICES; COMPUTER SOFTWARE FOR
THE COLLECTION AND SHARING OF DATA AND
INFORMATION; COMPUTER SOFTWARE FOR THE
COLLECTION AND SHARING OF DATA AND INFOR-
MATION THROUGH THE USE OF A GLOBAL POSI-
TIONING SYSTEM (GPS); GLOBAL POSITIONING
SYSTEM (GPS) CONSISTING OF COMPUTERS, COMPU-
TER SOFTWARE, TRANSMITTERS, RECEIVERS, AND
NETWORK INTERFACE DEVICES (U.S. CLS. 21, 23, 26,
36 AND 38).

FIRST USE 7-14-2010; IN COMMERCE 11-12-2010.

SKYE YOUNG, EXAMINING ATTORNEY

CLASS 9—(Continued).

SN 85-277,647. DATABABIES L.L.C., IOWA CITY, IA. FILED 3-25-2011.

dataBabies

THE MARK CONSISTS OF STANDARD CHARACTERS WITHOUT CLAIM TO ANY PARTICULAR FONT, STYLE, SIZE, OR COLOR.

FOR BLANK USB FLASH DRIVES WITH PLUSH TOY COVERINGS (U.S. CLS. 21, 23, 26, 36 AND 38).

FIRST USE 3-7-2011; IN COMMERCE 3-7-2011.

DAVID H. STINE, EXAMINING ATTORNEY

CLASS 9—(Continued).

SN 85-277,952. OPSIS DISTRIBUTION LLC, DBA PANELFLY, NEW YORK, NY. FILED 3-26-2011.

Panelfly

THE MARK CONSISTS OF STANDARD CHARACTERS WITHOUT CLAIM TO ANY PARTICULAR FONT, STYLE, SIZE, OR COLOR.

FOR DOWNLOADABLE AUDIO-VISUAL MEDIA CONTENT IN THE FIELDS OF CURRENT EVENT NEWS, ENTERTAINMENT, SPORTS, COMEDY, DRAMA, MUSIC, AND MUSIC VIDEOS; COMPUTER SOFTWARE, NAMELY, COMPUTER SOFTWARE FOR STREAMING AUDIO-VISUAL MEDIA CONTENT VIA THE INTERNET AND TO MOBILE DIGITAL ELECTRONIC DEVICES; COMPUTER SOFTWARE, NAMELY, DOWNLOADABLE PLAYERS FOR AUDIO-VISUAL MEDIA CONTENT, COMPUTER SOFTWARE, NAMELY, SOFTWARE TOOLS FOR EDITING OF AUDIO-VISUAL CONTENT; VIDEO SEARCH AND ANNOTATION SOFTWARE; SOFTWARE TO ENABLE AUDIO, VIDEO AND MEDIA CONTENT PROTECTION; ADVERTISEMENT TRACKING AND OPTIMIZATION SOFTWARE; COMPUTER SOFTWARE PLATFORM FOR PROVIDING PROGRAMMATIC INTERFACES FOR THIRD PARTIES TO ACCESS WEBSITE CONTENT AND DATA FOR WEB DEVELOPMENT AND WEBSITE APPLICATION DEVELOPMENT (U.S. CLS. 21, 23, 26, 36 AND 38).

FIRST USE 8-23-2009; IN COMMERCE 8-23-2009.

ANDREA BUTLER, EXAMINING ATTORNEY

SN 85-277,862. SIMPLIVT CORPORATION, WESTBOROUGH, MA. FILED 3-26-2011.

INTOACTION TECHNOLOGIES

THE MARK CONSISTS OF STANDARD CHARACTERS WITHOUT CLAIM TO ANY PARTICULAR FONT, STYLE, SIZE, OR COLOR.

NO CLAIM IS MADE TO THE EXCLUSIVE RIGHT TO USE "TECHNOLOGIES", APART FROM THE MARK AS SHOWN.

FOR COMPUTER HARDWARE AND SOFTWARE FOR COMPUTER SERVER AND DATA STORAGE VIRTUALIZATION (U.S. CLS. 21, 23, 26, 36 AND 38).

B. PARADEWELAI, EXAMINING ATTORNEY

SN 85-278,074. NUHERTZ TECHNOLOGIES, LLC, PHOENIX, AZ. FILED 3-27-2011.

NUHERTZ TECHNOLOGIES

THE MARK CONSISTS OF STANDARD CHARACTERS WITHOUT CLAIM TO ANY PARTICULAR FONT, STYLE, SIZE, OR COLOR.

OWNER OF U.S. REG. NOS. 2,382,762, 2,831,786 AND 3,310,731.

NO CLAIM IS MADE TO THE EXCLUSIVE RIGHT TO USE "TECHNOLOGIES", APART FROM THE MARK AS SHOWN.

FOR COMPUTER SOFTWARE DEVELOPMENT TOOLS; COMPUTER SOFTWARE FOR USE IN ELECTRICAL ENGINEERING DEVELOPMENT, NAMELY, FOURIER SPECTRAL ANALYSIS, ANALOG AND DIGITAL FILTER SYNTHESIS AND ANALYSIS THAT MAY BE DOWNLOADED FROM A GLOBAL COMPUTER NETWORK (U.S. CLS. 21, 23, 26, 36 AND 38).

FIRST USE 3-21-2000; IN COMMERCE 3-21-2000.

JILL PRATER, EXAMINING ATTORNEY

CLASS 9—(Continued).

SN 85-278,114. BATTERY BEAST, LLC, DBA BATTERY BEAST, LLC, WALLACE, ID. FILED 3-27-2011.

Battery Beast

THE MARK CONSISTS OF STANDARD CHARACTERS WITHOUT CLAIM TO ANY PARTICULAR FONT, STYLE, SIZE, OR COLOR.

NO CLAIM IS MADE TO THE EXCLUSIVE RIGHT TO USE "BATTERY", APART FROM THE MARK AS SHOWN. FOR BATTERIES AND BATTERY CHARGERS (U.S. CLS. 21, 23, 26, 36 AND 38).

ANGELA M. MICHELI, EXAMINING ATTORNEY

SN 85-278,654. PINNACLE PEAK HOLDING CORPORATION, DBA SETCOM CORPORATION, AUSTIN, TX. FILED 3-28-2011.

Setcom

THE MARK CONSISTS OF THE STYLIZED WORD "SETCOM".

FOR COMMUNICATIONS HEADSETS FOR USE WITH COMMUNICATION RADIOS, INTERCOM SYSTEMS, AND OTHER COMMUNICATIONS NETWORK TRANSCEIVERS; COMMUNICATIONS HEADSETS WHICH PROVIDE HEARING PROTECTION AND ARE FOR USE WITH COMMUNICATION RADIOS, INTERCOM SYSTEMS, AND OTHER COMMUNICATIONS NETWORK TRANSCEIVERS; COMMUNICATIONS HEADSETS FOR USE WITH COMMUNICATION RADIOS, INTERCOM SYSTEMS, AND OTHER COMMUNICATIONS NETWORK TRANSCEIVERS; DEVICES FOR WIRELESS RADIO TRANSMISSION; INTERCOMS; SPEAKER-MICROPHONES FOR USE WITH COMMUNICATION RADIOS, INTERCOM SYSTEMS, AND OTHER COMMUNICATIONS NETWORK TRANSCEIVERS; DEVICES FOR CONTROLLING COMMUNICATION RADIOS AND INTERCOM SYSTEMS; PORTABLE RADIO ADAPTER CABLES; PUBLIC ADDRESS SYSTEM INTERFACE CABLES; TWO-WAY RADIO ADAPTER CABLES; MOBILE RADIO ADAPTER CABLES (U.S. CLS. 21, 23, 26, 36 AND 38).

FIRST USE 12-31-1975; IN COMMERCE 12-31-1975.
SHARON MEIER, EXAMINING ATTORNEY

CLASS 9—(Continued).

SN 85-278,691. SPECTRUM TRACKING SYSTEMS, INC., CARROLLTON, TX. FILED 3-28-2011.

BlueTrac Solutions

NO CLAIM IS MADE TO THE EXCLUSIVE RIGHT TO USE "SOLUTIONS", APART FROM THE MARK AS SHOWN.

THE MARK CONSISTS OF THE WORDS "BLUETRAC SOLUTIONS" WITH THE WORD "SOLUTIONS" IN A RECTANGLE.

FOR ELECTRONIC ANTI-THEFT TRACKING DEVICES FOR USE BY LAW ENFORCEMENT; TRACKING DEVICE KITS CONSISTING OF TRANSMITTERS, BATTERIES AND BATTERY CHARGERS, ANTI-STATIC PADS WITH WRIST STRAPS, MAGNETIC DEACTIVATION PLATES AND CONTAINERS FOR DEACTIVATING TRANSMITTERS, DIGITAL SIGNAL PROCESSORS AND RECEIVERS WITH VISUAL AND AUDIO DISPLAYS, EAR BUDS, ANTENNA, CABLES, AND POWER CORDS, SOLD IN VARIOUS COMBINATIONS AS A UNIT, INCLUDING CELLULAR SERVICE, FOR USE BY LAW ENFORCEMENT (U.S. CLS. 21, 23, 26, 36 AND 38).

FIRST USE 4-4-2009; IN COMMERCE 4-4-2009.
JESSICA A. POWERS, EXAMINING ATTORNEY

SN 85-278,704. PINNACLE PEAK HOLDING CORPORATION, DBA SETCOM CORPORATION, AUSTIN, TX. FILED 3-28-2011.

Setcom

THE COLOR(S) RED AND BLACK IS/ARE CLAIMED AS A FEATURE OF THE MARK.

THE MARK CONSISTS OF THE STYLIZED WORD "SETCOM" WHERE THE "SET" PORTION OF THE MARK IS RED AND THE "COM" PORTION OF THE MARK IS BLACK.

FOR COMMUNICATIONS HEADSETS FOR USE WITH COMMUNICATION RADIOS, INTERCOM SYSTEMS, AND OTHER COMMUNICATIONS NETWORK TRANSCEIVERS; COMMUNICATIONS HEADSETS WHICH PROVIDE HEARING PROTECTION AND ARE FOR USE WITH COMMUNICATION RADIOS, INTERCOM SYSTEMS, AND OTHER COMMUNICATIONS NETWORK TRANSCEIVERS; COMMUNICATIONS HEADSETS FOR USE WITH COMMUNICATION RADIOS, INTERCOM SYSTEMS, AND OTHER COMMUNICATIONS NETWORK TRANSCEIVERS; DEVICES FOR WIRELESS RADIO TRANSMISSION; INTERCOMS; SPEAKER-MICROPHONES FOR USE WITH COMMUNICATION RADIOS, INTERCOM SYSTEMS, AND OTHER COMMUNICATIONS NETWORK TRANSCEIVERS; DEVICES FOR CONTROLLING COMMUNICATION RADIOS AND INTERCOM SYSTEMS; PORTABLE RADIO ADAPTER CABLES; PUBLIC ADDRESS SYSTEM INTERFACE CABLES; TWO-WAY RADIO ADAPTER CABLES; MOBILE RADIO ADAPTER CABLES (U.S. CLS. 21, 23, 26, 36 AND 38).

FIRST USE 12-31-1986; IN COMMERCE 12-31-1986.
SHARON MEIER, EXAMINING ATTORNEY

CLASS 9—(Continued).

SN 85-278,939. HUAWEI TECHNOLOGIES CO., LTD., SHENZHEN, CHINA, FILED 3-28-2011.

HUAWEI CORONA

THE MARK CONSISTS OF STANDARD CHARACTERS WITHOUT CLAIM TO ANY PARTICULAR FONT, STYLE, SIZE, OR COLOR.

OWNER OF U.S. REG. NOS. 2,750,650, 3,313,908 AND 3,854,515.

FOR MOBILE TELEPHONES; MODEMS; USB MODEMS; WIRELESS MODEMS; COMPUTERS; DIGITAL PHOTO FRAMES FOR DISPLAYING DIGITAL PICTURES, VIDEO CLIPS AND MUSIC; TABLET COMPUTERS; DIGITAL BOOK READERS; PERSONAL DIGITAL ASSISTANTS (PDA); NETWORK ROUTERS; GATEWAY ROUTERS IN THE NATURE OF COMPUTER CONTROL HARDWARE; COMPUTER HARDWARE AND PERIPHERAL DEVICES AND COMPUTER SOFTWARE FOR DATA COMMUNICATION AND TRANSLATING AND TRANSMITTING DATA SOLD THEREWITH; ELECTRONIC COMMUNICATIONS SYSTEMS COMPRISED OF COMPUTER HARDWARE AND SOFTWARE FOR THE TRANSMISSION OF DATA BETWEEN TWO POINTS (U.S. CLS. 21, 23, 26, 36 AND 38).

JULIE GUTTADAURO, EXAMINING ATTORNEY

CLASS 9—(Continued).

SN 85-280,667. TANGLED WEB COMMUNICATIONS, LLC, MANHATTAN BEACH, CA. FILED 3-29-2011.

Wanna Bet?

THE MARK CONSISTS OF STANDARD CHARACTERS WITHOUT CLAIM TO ANY PARTICULAR FONT, STYLE, SIZE, OR COLOR.

FOR COMPUTER APPLICATION SOFTWARE FOR MOBILE PHONES, NAMELY, SOFTWARE FOR PEER-TO-PEER COMMUNICATION OF FRIENDLY, NON-MONETARY CHALLENGES TO OTHER MOBILE PHONE USERS; COMPUTER APPLICATION SOFTWARE FOR MOBILE PHONES, PERSONAL DATA ASSISTANTS (PDAS), MOBILE COMPUTERS AND TABLET COMPUTERS, NAMELY, SOFTWARE FOR PEER-TO-PEER COMMUNICATION OF FRIENDLY, NON-MONETARY CHALLENGES TO OTHER USERS OF THESE DEVICES; COMPUTER GAME SOFTWARE FOR USE ON MOBILE AND CELLULAR PHONES; DOWNLOADABLE SOFTWARE IN THE NATURE OF A MOBILE APPLICATION FOR PEER-TO-PEER COMMUNICATION OF FRIENDLY, NON-MONETARY CHALLENGES TO OTHER MOBILE DEVICE USERS (U.S. CLS. 21, 23, 26, 36 AND 38).

EDWARD FENNESSY, EXAMINING ATTORNEY

SN 85-280,673. TANGLED WEB COMMUNICATIONS, LLC, MANHATTAN BEACH, CA. FILED 3-29-2011.

SN 85-279,216. BLUEYECD, LLC, DUNWOODY, GA. FILED 3-28-2011.

BlueyeCD

THE MARK CONSISTS OF STANDARD CHARACTERS WITHOUT CLAIM TO ANY PARTICULAR FONT, STYLE, SIZE, OR COLOR.

FOR AUDIO DISCS, OPTICAL COMPACT DISCS AND OPTICAL DISCS CONTAINING TRANSCIVERS FOR STORING AND WIRELESSLY STREAMING DIGITAL AUDIO AND VIDEO DATA THROUGH CD AND DVD READERS AND PLAYERS (U.S. CLS. 21, 23, 26, 36 AND 38).

JEFFERY COWARD, EXAMINING ATTORNEY

WannaBet?

THE MARK CONSISTS OF STANDARD CHARACTERS WITHOUT CLAIM TO ANY PARTICULAR FONT, STYLE, SIZE, OR COLOR.

FOR COMPUTER APPLICATION SOFTWARE FOR MOBILE PHONES, NAMELY, SOFTWARE FOR PEER-TO-PEER COMMUNICATION OF FRIENDLY, NON-MONETARY CHALLENGES TO OTHER MOBILE PHONE USERS; COMPUTER APPLICATION SOFTWARE FOR MOBILE PHONES, PERSONAL DATA ASSISTANTS (PDAS), MOBILE COMPUTERS AND TABLET COMPUTERS, NAMELY, SOFTWARE FOR PEER-TO-PEER COMMUNICATION OF FRIENDLY, NON-MONETARY CHALLENGES TO OTHER USERS OF THESE DEVICES; COMPUTER GAME SOFTWARE FOR USE ON MOBILE AND CELLULAR PHONES; DOWNLOADABLE SOFTWARE IN THE NATURE OF A MOBILE APPLICATION FOR PEER-TO-PEER COMMUNICATION OF FRIENDLY, NON-MONETARY CHALLENGES TO OTHER MOBILE DEVICE USERS (U.S. CLS. 21, 23, 26, 36 AND 38).

EDWARD FENNESSY, EXAMINING ATTORNEY

CLASS 9—(Continued).

SN 85-281,036. BEIJING ZHIRUI TECHNOLOGY LIMITED, BEIJING, CHINA, FILED 3-30-2011.

AnTuTu

THE MARK CONSISTS OF THE STYLISTED LETTERING "ANTUTU".

THE WORDING "ANTUTU" HAS NO MEANING IN A FOREIGN LANGUAGE.

FOR ACOUSTIC COUPLERS; APPARATUS FOR RECORDING, TRANSMISSION, PROCESSING AND REPRODUCTION OF SOUND, IMAGES OR DATA; BLANK OPTICAL DISCS; BLANK OPTICAL DISKS; CALCULATING MACHINES AND DATA PROCESSING EQUIPMENT; CARRYING CASES, HOLDERS, PROTECTIVE CASES AND STANDS FEATURING POWER SUPPLY CONNECTORS, ADAPTORS, SPEAKERS AND BATTERY CHARGING DEVICES, SPECIALLY ADAPTED FOR USE WITH HANDHELD DIGITAL ELECTRONIC DEVICES; COMPUTER CURSOR CONTROL DEVICES, NAMELY, COMPUTER MOUSE; COMPUTER GAME PROGRAMS; COMPUTER KEYBOARDS; COMPUTER MOUSE; COMPUTER MOUSE IN THE NATURE OF A TRACKPAD; COMPUTER OPERATING PROGRAMS AND COMPUTER OPERATING SYSTEMS; COMPUTER OPERATING PROGRAMS, RECORDED; COMPUTER OPERATING RECORDED PROGRAMS; COMPUTER OPERATING SOFTWARE; COMPUTER PROGRAMS FOR PRE-RECORDED GAMES; COMPUTER PROGRAMS RECORDED ON DATA MEDIA (SOFTWARE) DESIGNED FOR USE IN CONSTRUCTION AND AUTOMATED MANUFACTURING (CAD/CAM); COMPUTER-GAMING SOFTWARE; COMPUTERS; CONSUMER ELECTRONIC PRODUCTS, NAMELY, AUDIO AMPLIFIERS, AUDIO SPEAKERS, AUDIO RECEIVERS, ELECTRICAL AUDIO AND SPEAKER CABLES AND CONNECTORS, AUDIO DECODERS, VIDEO DECODERS, SPEAKERS, POWER CONVERSION DEVICES, POWER CONVERTERS, AND POWER INVERTERS; DATA PROCESSORS; DOWNLOADABLE COMPUTER SOFTWARE FOR USE AS A SPREADSHEET, WORD PROCESSING; DOWNLOADABLE COMPUTER SOFTWARE IN THE FIELD OF MEMORY TRAINING ACTIVITIES SOLD AS A UNIT WITH POSITIONABLE FIGURES; DOWNLOADABLE SOFTWARE FOR USE IN DATABASE MANAGEMENT, FOR USE AS A SPREADSHEET, FOR WORD PROCESSING.; ELECTRONIC NAVIGATIONAL AND POSITIONING APPARATUS AND INSTRUMENTS; ELECTRONIC SOFTWARE UPDATES, NAMELY, DOWNLOADABLE COMPUTER SOFTWARE AND ASSOCIATED DATA FILES FOR UPDATING COMPUTER SOFTWARE IN THE FIELDS OF TELECOMMUNICATION, PROVIDED VIA COMPUTER AND COMMUNICATION NETWORKS; LAPTOP COMPUTERS; MULTIMEDIA SOFTWARE RECORDED ON CD-ROM FEATURING HANDLING, OPERATING AND ADJUSTING MECHANICALLY-OPERATED MACHINE TOOLS; NAVIGATION APPARATUS FOR VEHICLES IN THE NATURE OF ON-BOARD COMPUTERS; NOTEBOOK COMPUTERS; OPTICAL DISC DRIVES; OPTICAL DISC PLAYERS; OPTICAL DISCS CONTAINING SOFTWARE AND PROGRAMMING, USED TO SET-UP AND CALIBRATE TELEVISIONS AND VIDEO OUTPUT DEVICES; PORTABLE TELEPHONES; RECORDED COMPUTER GAME PROGRAMS; SATELLITE NAVIGATIONAL SYSTEM, NAMELY, A GLOBAL POSITIONING SYSTEM (GPS); TELEPHONE APPARATUS; VIDEO TELEPHONES; WRIST SUPPORTS FOR COMPUTER MOUSE USERS (U.S. CLS. 21, 23, 26, 36 AND 38).

NORA BUCHANAN WILL, EXAMINING ATTORNEY

CLASS 9—(Continued).

SN 85-281,224. GENERAL SEPARATION TECHNOLOGIES, INC., AKA GS-TEK, NEWARK, DE. FILED 3-30-2011.

GsBP

THE MARK CONSISTS OF STANDARD CHARACTERS WITHOUT CLAIM TO ANY PARTICULAR FONT, STYLE, SIZE, OR COLOR.

FOR CHROMATOGRAPHY COLUMNS; CHROMATOGRAPHY COLUMNS FOR USE IN PURIFICATION IN THE LABORATORY; LABORATORY APPARATUS AND INSTRUMENTS, NAMELY, PRE-PACKED COLUMNS FOR USE IN SEPARATION AND PURIFICATION; SCIENTIFIC APPARATUS AND INSTRUMENTS, NAMELY, CHROMATOGRAPHY COLUMNS FOR USE IN PURIFICATION IN THE LABORATORY AND PARTS AND FITTINGS THEREFOR (U.S. CLS. 21, 23, 26, 36 AND 38).

FIRST USE 12-28-2008; IN COMMERCE 4-5-2009.
KELLEY WELLS, EXAMINING ATTORNEY

SN 85-281,464. THEMIS, FREMONT, CA. FILED 3-30-2011.

RUGGEDSTORE

THE MARK CONSISTS OF STANDARD CHARACTERS WITHOUT CLAIM TO ANY PARTICULAR FONT, STYLE, SIZE, OR COLOR.

FOR COMPUTER HARDWARE STORAGE SYSTEM FOR STORAGE OF DATA ACCESSIBLE FROM A COMPUTER OR A NETWORK, INCORPORATING SOFTWARE AND HARDWARE FOR THE STORAGE AND RETRIEVAL OF FILES (U.S. CLS. 21, 23, 26, 36 AND 38).

MAYUR VAGHANI, EXAMINING ATTORNEY

CLASS 9—(Continued).

SN 85-281,748. TYFONE, INC., PORTLAND, OR. FILED 3-30-2011.

SIDETAP

THE MARK CONSISTS OF STANDARD CHARACTERS WITHOUT CLAIM TO ANY PARTICULAR FONT, STYLE, SIZE, OR COLOR.

FOR FLASH MEMORY CARDS, INTEGRATED SMART CARD CHIPS, AND NEAR FIELD COMMUNICATION (NFC) CHIPS THAT FACILITATE PAYMENT TRANSACTIONS USING MOBILE COMMUNICATION DEVICES, AND TO OTHERWISE FACILITATE MOBILE BANKING, MOBILE RETAIL, MOBILE REMITTANCES, MICROFINANCE, AND MOBILE IDENTITY MANAGEMENT; COMPUTER SOFTWARE, NAMELY, PRE-LOADED APPLICATION FIRMWARE ON ELECTRONIC MEMORY CARDS TO FACILITATE PAYMENT TRANSACTIONS USING MOBILE COMMUNICATION DEVICES, AND TO OTHERWISE FACILITATE MOBILE BANKING, MOBILE RETAIL, MOBILE REMITTANCES, MICROFINANCE, AND MOBILE IDENTITY MANAGEMENT; COMPUTER SOFTWARE, NAMELY, ELECTRONIC FINANCIAL PLATFORM AND INFRASTRUCTURE SOFTWARE FOR CREDIT CARD PROCESSORS AND INTERMEDIARIES, FINANCIAL INSTITUTIONS, AND FINANCIAL LENDERS THAT ACCOMMODATES PAYMENT TRANSACTIONS FROM MOBILE COMMUNICATION DEVICES, MOBILE BANKING, MOBILE RETAIL, MOBILE REMITTANCES, MICROFINANCE, AND MOBILE IDENTITY MANAGEMENT AND TO OTHERWISE SUPPORT END-TO-END SECURITY AND OVER-THE AIR PERSONALIZATION AND PROVISIONING IN CONNECTION WITH SAID TRANSACTIONS AND FUNCTIONS; COMPUTER SOFTWARE, NAMELY, SECURITY AND IDENTITY MANAGEMENT PLATFORM AND INFRASTRUCTURE SOFTWARE FOR MOBILE COMMUNICATION DEVICES, MOBILE BANKING, MOBILE RETAIL, MOBILE REMITTANCES, MICROFINANCE, AND MOBILE IDENTITY MANAGEMENT AND TO OTHERWISE SUPPORT END-TO-END SECURITY AND OVER-THE AIR PERSONALIZATION AND PROVISIONING IN CONNECTION WITH SAID FUNCTIONS; ANTENNAS FOR MOBILE COMMUNICATION DEVICES TO FACILITATE PAYMENT TRANSACTIONS USING SAID DEVICES, AND TO FACILITATE MOBILE BANKING, MOBILE RETAIL, MOBILE REMITTANCES, MICROFINANCE, AND MOBILE IDENTITY MANAGEMENT; BOOSTER APPARATUS THAT AMPLIFIES INCOMING ELECTROMAGNETIC SIGNALS FOR MOBILE COMMUNICATION DEVICES TO FACILITATE PAYMENT TRANSACTIONS USING SAID DEVICES, AND TO FACILITATE MOBILE BANKING, MOBILE RETAIL, MOBILE REMITTANCES, MICROFINANCE, AND MOBILE IDENTITY MANAGEMENT (U.S. CLS. 21, 23, 26, 36 AND 38).

TINA BROWN, EXAMINING ATTORNEY

CLASS 9—(Continued).

SN 85-281,875. UNDERHORSE ENTERTAINMENT, INC., REDMOND, WA. FILED 3-31-2011.

UNDERHORSE ENTERTAINMENT

THE MARK CONSISTS OF STANDARD CHARACTERS WITHOUT CLAIM TO ANY PARTICULAR FONT, STYLE, SIZE, OR COLOR.

NO CLAIM IS MADE TO THE EXCLUSIVE RIGHT TO USE "ENTERTAINMENT", APART FROM THE MARK AS SHOWN.

FOR COMPUTER GAME SOFTWARE (U.S. CLS. 21, 23, 26, 36 AND 38).

SHANNON TWOHIG, EXAMINING ATTORNEY

SN 85-282,399. SCHMIDT, CORY, NISSWA, MN. FILED 3-31-2011.

Bass Live!

THE MARK CONSISTS OF STANDARD CHARACTERS WITHOUT CLAIM TO ANY PARTICULAR FONT, STYLE, SIZE, OR COLOR.

NO CLAIM IS MADE TO THE EXCLUSIVE RIGHT TO USE "BASS", APART FROM THE MARK AS SHOWN.

FOR DIGITAL MEDIA, NAMELY, PRE-RECORDED VIDEO CASSETTES, DIGITAL VIDEO DISCS, DIGITAL VERSATILE DISCS, DOWNLOADABLE AUDIO AND VIDEO RECORDINGS, DVDS, AND HIGH DEFINITION DIGITAL DISCS FEATURING WILDLIFE AND OUTDOOR RECREATION ACTIVITIES (U.S. CLS. 21, 23, 26, 36 AND 38).

PRISCILLA MILTON, EXAMINING ATTORNEY

SN 85-283,792. MATTEL, INC., EL SEGUNDO, CA. FILED 4-1-2011.

GHOUL BOX

THE MARK CONSISTS OF STANDARD CHARACTERS WITHOUT CLAIM TO ANY PARTICULAR FONT, STYLE, SIZE, OR COLOR.

FOR VIDEO GAME SOFTWARE FOR MOBILE DEVICES AND TABLETS (U.S. CLS. 21, 23, 26, 36 AND 38).

ASMAT KHAN, EXAMINING ATTORNEY

CLASS 9—(Continued).

SN 85-283,840. SOLAR POWER TECHNOLOGIES, AUSTIN, TX. FILED 4-1-2011.

CLARITY

THE MARK CONSISTS OF STANDARD CHARACTERS WITHOUT CLAIM TO ANY PARTICULAR FONT, STYLE, SIZE, OR COLOR.

FOR ELECTRONIC MONITORS AND MONITORING MODULES FOR SOLAR POWER CELL, SOLAR MODULE AND SOLAR ARRAY SELF-MONITORING AND REPORTING OF PROBLEMS; APPARATUS FOR OPTIMIZATION OF POWER IN SOLAR POWER CELLS, SOLAR MODULES AND SOLAR ARRAYS; APPARATUS FOR TRANSMITTING INFORMATION AS TO POWER PRODUCTION, EFFICIENCY, IMPAIRMENTS, MAINTENANCE REQUIREMENTS AND DIAGNOSTICS IN SOLAR POWER CELLS, SOLAR MODULES AND SOLAR ARRAYS (U.S. CLS. 21, 23, 26, 36 AND 38).

H. M. FISHER, EXAMINING ATTORNEY

CLASS 9—(Continued).

SN 85-284,633. FISHER TECHNOLOGY PLC, LONDON, UNITED KINGDOM, FILED 4-2-2011.



NO CLAIM IS MADE TO THE EXCLUSIVE RIGHT TO USE "WEB FORMS FOR IMIS", APART FROM THE MARK AS SHOWN.

THE COLOR(S) PURPLE AND GREEN IS/ARE CLAIMED AS A FEATURE OF THE MARK.

THE MARK CONSISTS OF THE WORD "WEBFORMZ" FOR "IMIS" WITH A CAPITAL "W", CAPITAL "F" AND ENDING WITH A CAPITAL "Z". THE WORDING "WEB" AND "FOR IMIS" IS IN PURPLE AND "FORMZ" IS IN GREEN. A STYLIZED LETTER "Z" CONSISTING OF ONE GREEN QUADRILATERAL SHAPE AND MULTIPLE PURPLE SHAPES IS TO THE RIGHT.

FOR COMPUTER SOFTWARE FOR USE IN CUSTOMER RELATIONSHIP MANAGEMENT (CRM) (U.S. CLS. 21, 23, 26, 36 AND 38).

JOHN E. MICHOS, EXAMINING ATTORNEY

SN 85-285,870. CULINAPP, L.L.C., BELLAIRE, TX. FILED 4-4-2011.

CulinApp

CASH CRUISE

THE MARK CONSISTS OF STANDARD CHARACTERS WITHOUT CLAIM TO ANY PARTICULAR FONT, STYLE, SIZE, OR COLOR.

NO CLAIM IS MADE TO THE EXCLUSIVE RIGHT TO USE "CASH", APART FROM THE MARK AS SHOWN.

FOR GAMING MACHINES, NAMELY, DEVICES WHICH ACCEPT A WAGER AND GAMING SOFTWARE THAT GENERATES OR DISPLAYS OUTCOMES FOR GAMING MACHINES (U.S. CLS. 21, 23, 26, 36 AND 38).

WENDY GOODMAN, EXAMINING ATTORNEY

THE MARK CONSISTS OF STANDARD CHARACTERS WITHOUT CLAIM TO ANY PARTICULAR FONT, STYLE, SIZE, OR COLOR.

FOR COMPUTER SOFTWARE AVAILABLE THROUGH DOWNLOADS, COMPUTER READABLE MEMORY STORAGE AND THE INTERNET FOR DATABASE MANAGEMENT IN THE FIELD OF CULINARY FEATURING INTERACTIVE FOOD PREPARATION INSTRUCTIONS AND DISPLAYS, SUGGESTIONS FOR RECIPES, ENTREES, SIDE ITEMS BASED ON AGE OF FOOD, CULINARY PROFILE OF GUESTS, AVAILABLE INGREDIENTS AND AVAILABLE TIME, INFORMATION ABOUT FOOD, WINE, BEVERAGES, COOKING, BAKING, ENTERTAINING, RECIPES, DIET, NUTRITIONAL ADVICE, DINING AND RESTAURANT INFORMATION, KITCHEN DESIGN, EQUIPMENT AND ACCESSORIES (U.S. CLS. 21, 23, 26, 36 AND 38).

BRIDGETT SMITH, EXAMINING ATTORNEY

CLASS 9—(Continued).

SN 85-285,880. SAMSUNG ELECTRONICS CO., LTD., SU-WON-SI, GYEONGGI-DO, REPUBLIC OF KOREA, FILED 4-4-2011.

SAMSUNG VIND UI

THE MARK CONSISTS OF STANDARD CHARACTERS WITHOUT CLAIM TO ANY PARTICULAR FONT, STYLE, SIZE, OR COLOR.

OWNER OF U.S. REG. NOS. 2,929,519, 3,503,660 AND OTHERS.

NO CLAIM IS MADE TO THE EXCLUSIVE RIGHT TO USE "UI", APART FROM THE MARK AS SHOWN.

THE ENGLISH TRANSLATION OF "SAMSUNG" IN THE MARK IS "THREE STARS" AND "VIND" IN THE MARK MEANS "WIND".

FOR COMPUTER SOFTWARE FOR MOBILE PHONES, SMART PHONES AND TABLET COMPUTERS; MOBILE PHONES; SMARTPHONES; TABLET COMPUTER (U.S. CLS. 21, 23, 26, 36 AND 38).

JULIE GUTTADAURO, EXAMINING ATTORNEY

SN 85-285,888. CULINAPP, L.L.C., BELLAIRE, TX. FILED 4-4-2011.

CulinView

THE MARK CONSISTS OF STANDARD CHARACTERS WITHOUT CLAIM TO ANY PARTICULAR FONT, STYLE, SIZE, OR COLOR.

FOR COMPUTER SOFTWARE AVAILABLE THROUGH DOWNLOADS, COMPUTER READABLE MEMORY STORAGE AND THE INTERNET FOR DATABASE MANAGEMENT IN THE FIELD OF CULINARY FEATURING INTERACTIVE FOOD PREPARATION INSTRUCTIONS AND DISPLAYS, SUGGESTIONS FOR RECIPES, ENTREES, SIDE ITEMS BASED ON AGE OF FOOD, CULINARY PROFILE OF GUESTS, AVAILABLE INGREDIENTS AND AVAILABLE TIME, INFORMATION ABOUT FOOD, WINE, BEVERAGES, COOKING, BAKING, ENTERTAINING, RECIPES, DIET, NUTRITIONAL ADVICE, DINING AND RESTAURANT INFORMATION, KITCHEN DESIGN, EQUIPMENT AND ACCESSORIES (U.S. CLS. 21, 23, 26, 36 AND 38).

BRIDGETT SMITH, EXAMINING ATTORNEY

CLASS 9—(Continued).

SN 85-285,901. WOOD RICHARD H, VICTORVILLE, CA. FILED 4-4-2011.

CoreSim

THE MARK CONSISTS OF STANDARD CHARACTERS WITHOUT CLAIM TO ANY PARTICULAR FONT, STYLE, SIZE, OR COLOR.

FOR COMPUTER PROGRAMS FOR USE AS A SPREADSHEET IN THE FIELD OF DESIGN OF SOFT MAGNETIC COMPONENTS, NAMELY, PULSE AND OTHER TRANSFORMERS, INDUCTIVE REACTORS, HIGH ENERGY PARTICLE ACCELERATORS, MAGNETIC IMAGING SYSTEMS AND MOST TYPES OF MAGNETIC SYSTEMS FEATURING MAGNETIC CORES (U.S. CLS. 21, 23, 26, 36 AND 38).

BRIDGETT SMITH, EXAMINING ATTORNEY

SN 85-285,910. HENDERSON, BRETT, HERMOSA BEACH, CA. FILED 4-4-2011.

Crawl Cam

THE MARK CONSISTS OF STANDARD CHARACTERS WITHOUT CLAIM TO ANY PARTICULAR FONT, STYLE, SIZE, OR COLOR.

NO CLAIM IS MADE TO THE EXCLUSIVE RIGHT TO USE "CAM", APART FROM THE MARK AS SHOWN.

FOR MODULAR MOBILE VIDEO CAMERA AND DISPLAY SYSTEM COMPRISED OF VIDEO CAMERAS THAT EACH ATTACH TO ONE OR MULTIPLE DISPLAYS IN THE CABIN OF A VEHICLE (U.S. CLS. 21, 23, 26, 36 AND 38).

BRIDGETT SMITH, EXAMINING ATTORNEY

SN 85-286,521. CODEWARE, INC., SARASOTA, FL. FILED 4-5-2011.

CODEWARE

OWNER OF U.S. REG. NO. 3,300,714.

THE COLOR(S) RED AND BLACK IS/ARE CLAIMED AS A FEATURE OF THE MARK.

THE MARK CONSISTS OF THE WORD "CODEWARE" WHEREIN THE LETTERS "C", "O", "D" AND "E" APPEAR IN RED; AND THE LETTERS "W", "A", "R" AND "E" APPEAR IN BLACK.

FOR COMPUTER SOFTWARE, NAMELY, SOFTWARE FOR THE DESIGN OF PRESSURE VESSELS AND HEAT EXCHANGERS (U.S. CLS. 21, 23, 26, 36 AND 38).

FIRST USE 12-17-2010; IN COMMERCE 12-17-2010.

INGRID C. EULIN, EXAMINING ATTORNEY

CLASS 9—(Continued).

SN 85-286,949. HALLMARK LICENSING, INC., KANSAS CITY, MO. FILED 4-5-2011.

CHRISTOPHER

THE MARK CONSISTS OF STANDARD CHARACTERS WITHOUT CLAIM TO ANY PARTICULAR FONT, STYLE, SIZE, OR COLOR.

THE NAME(S), PORTRAIT(S), AND/OR SIGNATURE(S) SHOWN IN THE MARK DOES NOT IDENTIFY A PARTICULAR LIVING INDIVIDUAL.

FOR VIDEO GAMES AND COMPUTER GAME PROGRAMS ALL FEATURING CHILDREN'S STORYBOOKS FOR MOBILE DEVICES, PERSONAL COMPUTERS, PC TABLETS; ELECTRONIC GAME PROGRAMS FEATURING CHILDREN'S STORYBOOKS; DOWNLOADABLE ELECTRONIC GAME PROGRAMS FEATURING CHILDREN'S STORYBOOKS; ELECTRONIC COMPUTER GAME SOFTWARE FEATURING CHILDREN'S STORYBOOKS; DOWNLOADABLE ELECTRONIC COMPUTER GAME PROGRAMS FEATURING CHILDREN'S STORYBOOKS; DOWNLOADABLE COMPUTER ELECTRONIC COMPUTER GAME PROGRAMS FEATURING CHILDREN'S STORYBOOKS; INTERACTIVE GAME PROGRAMS FEATURING CHILDREN'S STORYBOOKS; INTERACTIVE COMPUTER GAME SOFTWARE FEATURING CHILDREN'S STORYBOOKS (U.S. CLS. 21, 23, 26, 36 AND 38).

BERYL GARDNER, EXAMINING ATTORNEY

SN 85-287,686. NATIONAL COUNCIL OF YOUNG MEN'S CHRISTIAN ASSOCIATIONS OF THE UNITED STATES OF AMERICA, CHICAGO, IL. FILED 4-6-2011.



OWNER OF U.S. REG. NOS. 3,874,466, 3,917,712 AND OTHERS.

THE MARK CONSISTS OF THE TERM "THE" ON THE LEFT HAND SIDE OF A STYLIZED LETTER "Y" WHICH INCLUDES AN UPSIDE DOWN TRIANGULAR SHAPED OBJECT ON THE UPPER RIGHT CORNER. THE ACRONYM "YMCA" APPEARS ON THE BOTTOM RIGHT CORNER OF THE STYLIZED "Y".

FOR TUBE FOR USE IN WATER RESCUE (U.S. CLS. 21, 23, 26, 36 AND 38).

FIRST USE 8-1-2010; IN COMMERCE 8-1-2010.
BRENDAN REGAN, EXAMINING ATTORNEY

CLASS 9—(Continued).

SN 85-288,861. AUSTIN, KEITH R., SANTA BARBARA, CA. FILED 4-7-2011.

OnePass

THE MARK CONSISTS OF STANDARD CHARACTERS WITHOUT CLAIM TO ANY PARTICULAR FONT, STYLE, SIZE, OR COLOR.

FOR BLANK PROFESSIONAL BROADCAST DIGITAL AND ANALOG VIDEO TAPE; BLANK RECORDABLE MEDIA, NAMELY, CDS, DVDS AND DIGITAL VERSATILE DISCS; MEMORY CARDS (U.S. CLS. 21, 23, 26, 36 AND 38).

FIRST USE 5-1-2010; IN COMMERCE 5-1-2010.

WILLIAM ROSSMAN, EXAMINING ATTORNEY

SN 85-288,937. EBADOLAH, MEHRAN, LOS ANGELES, CA. FILED 4-7-2011.

Phonetasy

THE MARK CONSISTS OF STANDARD CHARACTERS WITHOUT CLAIM TO ANY PARTICULAR FONT, STYLE, SIZE, OR COLOR.

FOR COMPUTER APPLICATION SOFTWARE FOR MOBILE PHONES, NAMELY, SOFTWARE FOR PARTICIPATING IN FANTASY SPORTS LEAGUES AND ACCESSING NEWS AND INFORMATION RELATING TO FANTASY SPORTS (U.S. CLS. 21, 23, 26, 36 AND 38).

SUZANNE BLANE, EXAMINING ATTORNEY

SN 85-289,020. MOBUBBLE, INC, MURRIETA, CA. FILED 4-7-2011.

moBubble

THE MARK CONSISTS OF STANDARD CHARACTERS WITHOUT CLAIM TO ANY PARTICULAR FONT, STYLE, SIZE, OR COLOR.

FOR COMPUTER APPLICATION SOFTWARE FOR MOBILE PHONES, NAMELY, SOFTWARE FOR PROVIDING LOCATION PROXIMITY SEARCHES (U.S. CLS. 21, 23, 26, 36 AND 38).

DAVID HOFFMAN, EXAMINING ATTORNEY

CLASS 9—(Continued).

SN 85-290,023. JB SYSTEMS, INC., DBA IRIS SYSTEMS, INC., CLEARWATER, FL. FILED 4-8-2011.

IRIS 

THE MARK CONSISTS OF LETTERS THAT SPELL "IRIS" AND THE HUMAN EYE (IRIS)

FOR FLAME MONITORS FOR DETECTING THE PRESENCE, ABSENCE, AND/OR QUALITY OF A FLAME AS PART OF A BURNER MANAGEMENT SYSTEM FOR INDUSTRIAL BOILERS, HEATING FURNACES, AND REACTORS (U.S. CLS. 21, 23, 26, 36 AND 38).

FIRST USE 1-8-1981; IN COMMERCE 1-8-1981.
JAY FLOWERS, EXAMINING ATTORNEY

CLASS 9—(Continued).

SN 85-290,234. JENZABAR, INC., BOSTON, MA. FILED 4-8-2011.

FINISHLINE

THE MARK CONSISTS OF STANDARD CHARACTERS WITHOUT CLAIM TO ANY PARTICULAR FONT, STYLE, SIZE, OR COLOR.

FOR SOFTWARE FOR IDENTIFYING AND TRACKING STUDENTS AT RISK OF ATTRITION AT ACADEMIC INSTITUTIONS (U.S. CLS. 21, 23, 26, 36 AND 38).
LINDA ESTRADA, EXAMINING ATTORNEY

SN 85-290,060. THERMOWORKS, INC., LINDON, UT. FILED 4-8-2011.

Super-Fast

THE MARK CONSISTS OF STANDARD CHARACTERS WITHOUT CLAIM TO ANY PARTICULAR FONT, STYLE, SIZE, OR COLOR.

SEC. 2(F).
FOR INFRA-RED THERMOMETERS; LABORATORY EQUIPMENT AND SUPPLIES, NAMELY, THERMOMETERS; THERMOMETERS; THERMOMETERS NOT FOR MEDICAL USE (U.S. CLS. 21, 23, 26, 36 AND 38).

FIRST USE 6-1-2000; IN COMMERCE 6-1-2000.
KEVIN DINALLO, EXAMINING ATTORNEY

SN 85-290,276. EZPAYY, INC., DBA PRESSPAY, DENVER, CO. FILED 4-8-2011.



THE MARK CONSISTS OF TWO UPPER CASE LETTER "P'S" SIDE-BY-SIDE, WITH THE FIRST ONE PRINTED BACKWARDS, CONTAINED IN AN OVAL DESIGN.

FOR COMPUTER APPLICATION SOFTWARE FOR MOBILE PHONES, NAMELY SOFTWARE FOR PAYING FOR GOODS WIRELESSLY USING PAYMENT INFORMATION STORED ON A MOBILE DEVICE (U.S. CLS. 21, 23, 26, 36 AND 38).

FIRST USE 1-12-2011; IN COMMERCE 3-11-2011.
WARREN L. OLANDRIA, EXAMINING ATTORNEY

SN 85-290,212. JAYN INTERNATIONAL PTE LTD., SINGAPORE, SINGAPORE, FILED 4-8-2011.

Z7

THE MARK CONSISTS OF STANDARD CHARACTERS WITHOUT CLAIM TO ANY PARTICULAR FONT, STYLE, SIZE, OR COLOR.

FOR PROTECTIVE ARMOR PANELS FOR PROTECTING AGAINST BALLISTIC PROJECTILES AND EXPLOSIVE FRAGMENTS INSTALLED IN OR ATTACHED TO VEHICLES, BUILDINGS OR OTHER STRUCTURES (U.S. CLS. 21, 23, 26, 36 AND 38).

FIRST USE 11-15-2010; IN COMMERCE 11-15-2010.
JAQUELINE A. LAVINE, EXAMINING ATTORNEY

SN 85-290,687. IKEY, LTD., AUSTIN, TX. FILED 4-8-2011.

DT-102-EX

THE MARK CONSISTS OF STANDARD CHARACTERS WITHOUT CLAIM TO ANY PARTICULAR FONT, STYLE, SIZE, OR COLOR.

FOR COMPUTER PERIPHERALS, NAMELY, KEYBOARDS, INDUSTRIAL FLAT PANEL DISPLAYS, KEYBOARD EXTENDERS, WIRELESS KEYBOARDS, INDUSTRIAL COMPUTER ENCLOSURES, AND POINTING DEVICES, NAMELY, MICE, TRACKBALLS AND TOUCH PADS (U.S. CLS. 21, 23, 26, 36 AND 38).

MICHELLE DUBOIS, EXAMINING ATTORNEY

CLASS 9—(Continued).

SN 85-290,746. WANDERSPOT LLC, DBA URBANSPOON, SEATTLE, WA. FILED 4-8-2011.

URBANSPOON

THE MARK CONSISTS OF STANDARD CHARACTERS WITHOUT CLAIM TO ANY PARTICULAR FONT, STYLE, SIZE, OR COLOR.

OWNER OF U.S. REG. NO. 3,504,309.

FOR COMPUTER APPLICATION SOFTWARE AND DOWNLOADABLE SOFTWARE IN THE NATURE OF MOBILE APPLICATIONS FOR HANDHELD COMPUTERS, DIGITAL ELECTRONIC DEVICES, WIRELESS DEVICES AND INTERNET CAPABLE DEVICES THAT ALLOW USERS TO LOCATE RESTAURANTS AND PROVIDES INFORMATION ON RESTAURANTS, INCLUDING PRICES, COMPILATIONS, RANKINGS, RATINGS, REVIEWS, REFERRALS, CONTACT INFORMATION, AND RECOMMENDATIONS (U.S. CLS. 21, 23, 26, 36 AND 38).

KAREN K. BUSH, EXAMINING ATTORNEY

SN 85-290,822. NBA PROPERTIES, INC., NEW YORK, NY. FILED 4-8-2011.

ON FIRE

THE MARK CONSISTS OF STANDARD CHARACTERS WITHOUT CLAIM TO ANY PARTICULAR FONT, STYLE, SIZE, OR COLOR.

FOR AUDIO RECORDINGS AND VIDEO RECORDINGS FEATURING ENTERTAINMENT AND INFORMATION IN THE FIELD OF BASKETBALL; AUDIO DISCS, VIDEO DISCS, COMPUTER LASER DISCS, PRE-RECORDED AUDIO AND VIDEO CASSETTES, PRE-RECORDED AUDIO AND VIDEO TAPES, PRE-RECORDED COMPACT DISCS, PRE-RECORDED COMPUTER LASER DISCS, ALL FEATURING ENTERTAINMENT AND INFORMATION RELATED TO BASKETBALL; COMPUTER ACCESSORIES, NAMELY MOUSE PADS, MICE, DISC CASES, COMPUTER CARRY-ON CASES, KEYBOARD WRIST PADS, COMPUTER MONITOR CARDBOARD FRAMES, ALL RELATED TO BASKETBALL; COMPUTER PROGRAMS FOR VIEWING INFORMATION, STATISTICS OR TRIVIA ABOUT BASKETBALL; COMPUTER SOFTWARE, NAMELY SCREEN SAVERS FEATURING BASKETBALL THEMES; COMPUTER SOFTWARE TO ACCESS AND VIEW COMPUTER WALLPAPER; COMPUTER BROWSER SOFTWARE FOR USE IN VIEWING AND DISPLAYING DATA ON THE INTERNET; COMPUTER SKINS, NAMELY, FITTED PLASTIC FILM FOR COVERING AND PROVIDING A SCRATCH PROOF BARRIER FOR COMPUTER DEVICES; COMPUTER GAME SOFTWARE; VIDEO GAME SOFTWARE, VIDEO GAME CARTRIDGES AND VIDEO GAME MACHINES FOR USE WITH TELEVISION AND VIDEO GAME HAND HELD CONTROLLERS FOR USE WITH TELEVISIONS; WIRELESS TELEPHONES; RADIOS, TELEPHONES, AND CELL PHONE ACCESSORIES, NAMELY FACE PLATES AND CELL PHONE COVERS; VIDEO MONITORS, COMPUTER MONITORS, BINOCULARS; SUNGLASSES; EYEGLASS FRAMES; EYEWEAR STRAPS AND CHAINS; EYEGLASS AND SUNGLASS CASES; MAGNETS; DISPOSABLE CAMERAS; CREDIT CARDS AND PRE-PAID TELEPHONE CALLING CARDS MAGNETICALLY ENCODED; DOWNLOADABLE VIDEO RECORDINGS, VIDEO STREAM RECORDINGS,

CLASS 9—(Continued).

AND DOWNLOADABLE AUDIO RECORDINGS IN THE FIELD OF BASKETBALL PROVIDED OVER THE INTERNET; DOWNLOADABLE COMPUTER SOFTWARE FOR VIEWING DATABASES OF INFORMATION, STATISTICAL INFORMATION, TRIVIA, POLLING INFORMATION, AND INTERACTIVE POLLING IN THE FIELD OF BASKETBALL PROVIDED OVER THE INTERNET; DOWNLOADABLE COMPUTER GAME SOFTWARE; DOWNLOADABLE INTERACTIVE VIDEO GAMES AND DOWNLOADABLE TRIVIA GAME SOFTWARE PROVIDED OVER THE INTERNET; DOWNLOADABLE COMPUTER SOFTWARE FOR USE AS SCREENSAVERS AND WALLPAPER, TO ACCESS AND DISPLAY COMPUTER BROWSERS, FOR USE IN VIEWING DATA ON THE INTERNET, FOR USE IN DESIGNING PLASTIC FILM COMPUTER SKINS TO PROTECT COMPUTER MONITORS, FOR USE IN CREATING AVATARS FOR PLAYING GAMES AND FOR USE IN REMOTELY MANIPULATING COMPUTER CURSORS OVER THE INTERNET; DOWNLOADABLE ELECTRONIC PUBLICATIONS IN THE NATURE OF MAGAZINES, NEWSLETTERS, COLORING BOOKS, GAME SCHEDULES ALL IN THE FIELD OF BASKETBALL PROVIDED OVER THE INTERNET; DOWNLOADABLE CATALOGS PROVIDED OVER THE INTERNET FEATURING AN ARRAY OF BASKETBALL-THEMED PRODUCTS; DOWNLOADABLE GREETING CARDS PROVIDED OVER THE INTERNET (U.S. CLS. 21, 23, 26, 36 AND 38).

BARBARA BROWN, EXAMINING ATTORNEY

SN 85-290,918. ARTHUR GROSS III, IRVINE, CA. FILED 4-9-2011.

Made by God

THE MARK CONSISTS OF STANDARD CHARACTERS WITHOUT CLAIM TO ANY PARTICULAR FONT, STYLE, SIZE, OR COLOR.

FOR MAGNETIC CODED GIFT CARDS; MAGNETIC IDENTIFYING CARDS; MAGNETICALLY ENCODED CREDIT CARDS; MAGNETICALLY ENCODED DEBIT CARDS; MAGNETICALLY ENCODED IDENTITY CARDS; MAGNETICALLY ENCODED KEY CARDS (U.S. CLS. 21, 23, 26, 36 AND 38).

JAMES A. RAUEN, EXAMINING ATTORNEY

SN 85-290,928. TEXT PILOT LLC, DBA HITUP.COM, SAN FRANCISCO, CA. FILED 4-9-2011.

PARTYWALL

THE MARK CONSISTS OF STANDARD CHARACTERS WITHOUT CLAIM TO ANY PARTICULAR FONT, STYLE, SIZE, OR COLOR.

FOR ELECTRONIC DISPLAY INTERFACES (U.S. CLS. 21, 23, 26, 36 AND 38).

FIRST USE 12-11-2010; IN COMMERCE 12-11-2010.

MORGAN WYNNE, EXAMINING ATTORNEY

CLASS 9—(Continued).

SN 85-291,099. LEHOE, CHRISTOPHER W, EAST ST JOHNSBERRY, VT. AND MAGOON, MATTHEW P, SAINT JOHNSBURY, VT. FILED 4-9-2011.

Seconds Out

THE MARK CONSISTS OF STANDARD CHARACTERS WITHOUT CLAIM TO ANY PARTICULAR FONT, STYLE, SIZE, OR COLOR.

FOR APPARATUS FOR RECORDING AND REPRODUCTION OF SOUND, IMAGES OR DATA; APPARATUS FOR RECORDING, TRANSMISSION AND REPRODUCTION OF IMAGES; APPARATUS FOR RECORDING, TRANSMISSION OR REPRODUCTION OF SOUND; APPARATUS FOR RECORDING, TRANSMISSION OR REPRODUCTION OF SOUND AND IMAGES; APPARATUS FOR RECORDING, TRANSMISSION, PROCESSING AND REPRODUCTION OF SOUND, IMAGES OR DATA; APPARATUS FOR RECORDING, TRANSMITTING AND REPRODUCING SOUND AND IMAGES; APPARATUS FOR THE RECORDING, TRANSMISSION AND REPRODUCTION OF SOUND AND IMAGES; APPARATUS FOR TRANSMITTING AND REPRODUCING SOUND OR IMAGES; AUDIO AND VIDEO RECORDINGS FEATURING MUSIC AND ARTISTIC PERFORMANCES; AUDIO AND VIDEO RECORDINGS FEATURING MUSIC; AUDIO RECORDINGS FEATURING MUSIC; AUDIO TAPES FEATURING MUSIC; COMPACT DISCS FEATURING MUSIC; DIGITAL MEDIA, NAMELY, PRE-RECORDED DVDS, DOWNLOADABLE AUDIO AND VIDEO RECORDINGS, AND CDS FEATURING AND PROMOTING MUSIC; DIGITAL MUSIC DOWNLOADABLE FROM THE INTERNET; DOWNLOADABLE MUSICAL SOUND RECORDINGS; MUSICAL RECORDINGS; MUSICAL SOUND RECORDINGS; MUSICAL VIDEO RECORDINGS; SERIES OF MUSICAL SOUND RECORDINGS (U.S. CLS. 21, 23, 26, 36 AND 38).

COURTNEY ALVAREZ, EXAMINING ATTORNEY

SN 85-291,230. ROCHE,JASON,ANTHONY, DBA ROB-DA-INDUSTRY-RECORDZ, BRONX, NY. FILED 4-10-2011.

ROB-DA-INDUSTRY-RECORDZ

THE MARK CONSISTS OF STANDARD CHARACTERS WITHOUT CLAIM TO ANY PARTICULAR FONT, STYLE, SIZE, OR COLOR.

FOR COMPACT DISCS FEATURING MUSIC AND SPOKEN WORD IN THE FORM OF POETRY (U.S. CLS. 21, 23, 26, 36 AND 38).

CARYN GLASSER, EXAMINING ATTORNEY

CLASS 9—(Continued).

SN 85-291,266. WHIM LLC, CARY, NC. FILED 4-11-2011.

WHIM

THE MARK CONSISTS OF STANDARD CHARACTERS WITHOUT CLAIM TO ANY PARTICULAR FONT, STYLE, SIZE, OR COLOR.

FOR COMPUTER APPLICATION SOFTWARE FOR MOBILE PHONES, NAMELY, SOFTWARE FOR GEOLOCATION BASED ADVERTISING AND PRODUCT AND SERVICE PROMOTIONS; COMPUTER APPLICATION SOFTWARE FOR MOBILE PHONES AND HANDHELD ELECTRONIC DEVICES, NAMELY, SOFTWARE FOR APPLICATION PROGRAMMING INTERFACE (API) FOR ALLOWING DATA RETRIEVAL, UPLOAD, ACCESS AND MANAGEMENT; DOWNLOADABLE COMPUTER SOFTWARE FOR SOCIAL AND PERSONAL NETWORKING; DOWNLOADABLE SOFTWARE FOR DISPLAYING AND SHARING A USER'S LOCATION AND PERSONAL PREFERENCES AND FINDING, LOCATING, AND INTERACTING WITH OTHER USERS AND PLACES; DOWNLOADABLE SOFTWARE IN THE NATURE OF A MOBILE APPLICATION FOR A MOBILE APPLICATION FOR CREATING, SHARING, DISSEMINATING AND POSTING PHOTOS, VIDEOS, PERSONAL AND GENERAL INFORMATION FOR THE PURPOSES OF SOCIAL, PERSONAL AND PROFESSIONAL NETWORKING (U.S. CLS. 21, 23, 26, 36 AND 38).

KATHERINE M. DUBRAY, EXAMINING ATTORNEY

SN 85-291,351. E.O.M. DIGITAL ACCESSORIES, LTD., EDISON, NJ. FILED 4-11-2011.

NIKURA

THE MARK CONSISTS OF STANDARD CHARACTERS WITHOUT CLAIM TO ANY PARTICULAR FONT, STYLE, SIZE, OR COLOR.

FOR BATTERY PACKS FOR CAMERAS AND CAMCORDERS; CAMERA CASES; CAMERA FILTERS; CAMERA TRIPODS; ELECTRONIC MEMORY CARD READERS; HIGH DEFINITION MULTIMEDIA INTERFACE CABLES; LENS FILTERS; LENSES FOR CAMERAS; MEMORY CARDS; VOLTAGE SURGE PROTECTORS; WIDE-ANGLE LENSES FOR CAMERAS (U.S. CLS. 21, 23, 26, 36 AND 38).

FIRST USE 5-27-1983; IN COMMERCE 6-2-1983.

SUSAN LESLIE DUBOIS, EXAMINING ATTORNEY

CLASS 9—(Continued).

SN 85-291,426. FULCRUM MOBILE NETWORKS INC, SAMMAMISH, WA. FILED 4-11-2011.



THE COLOR(S) GREEN, ORANGE, AND WHITE IS/ARE CLAIMED AS A FEATURE OF THE MARK.

THE MARK CONSISTS OF THE WORDING "OPENXLIVE" WITH "OPEN" ON THE LEFT, "LIVE" ON THE RIGHT, BOTH IN WHITE LETTERS AND SEA GREEN STROKES, AND A STYLIZED "X" IN THE MIDDLE, WHICH IS CONSTITUTED BY SUPERPOSITION OF FOUR GREEN AND FOUR ORANGE DIAMOND-SHAPED GRAPHICS ON GREEN BACKGROUND.

FOR COMPUTER SOFTWARE DEVELOPMENT TOOLS; COMPUTER SOFTWARE PLATFORMS FOR ELECTRONIC GAMES (U.S. CLS. 21, 23, 26, 36 AND 38).

FIRST USE 2-15-2011; IN COMMERCE 2-15-2011.

MARILYN IZZI, EXAMINING ATTORNEY

CLASS 9—(Continued).

SN 85-291,879. GIBSON GUITAR CORP., NASHVILLE, TN. FILED 4-11-2011.

GIBSON

THE MARK CONSISTS OF STANDARD CHARACTERS WITHOUT CLAIM TO ANY PARTICULAR FONT, STYLE, SIZE, OR COLOR.

OWNER OF U.S. REG. NOS. 1,545,311, 3,877,181 AND OTHERS.

SEC. 2(F).

FOR BLANK RECORDABLE CD-RS AND DVD-RS; DVD BURNERS; ELECTRIC CABLES; VOLTAGE SURGE PROTECTORS (U.S. CLS. 21, 23, 26, 36 AND 38).

FIRST USE 12-31-2007; IN COMMERCE 12-31-2007.

KAREN K. BUSH, EXAMINING ATTORNEY

SN 85-292,068. TR THEATER RESEARCH, INC., CYPRESS, CA. FILED 4-11-2011.

SKYLINE MULTIMEDIA

THE MARK CONSISTS OF STANDARD CHARACTERS WITHOUT CLAIM TO ANY PARTICULAR FONT, STYLE, SIZE, OR COLOR.

NO CLAIM IS MADE TO THE EXCLUSIVE RIGHT TO USE "MULTIMEDIA", APART FROM THE MARK AS SHOWN.

FOR AUDIO SPEAKERS; MULTIMEDIA PROJECTORS; VIDEO PROJECTORS (U.S. CLS. 21, 23, 26, 36 AND 38).

WILLIAM ROSSMAN, EXAMINING ATTORNEY

SN 85-291,556. TEHRANI, FARSHAD, CULVER CITY, CA. AND WILLIS, JEFF, CULVER CITY, CA. FILED 4-11-2011.

NO CLAIM IS MADE TO THE EXCLUSIVE RIGHT TO USE "AUDIO", APART FROM THE MARK AS SHOWN.

THE MARK CONSISTS OF THE STYLIZED WORDING "TEGO AUDIO". IN THE WORD "TEGO", THE "T" APPEARS AS A PLUS SIGN, THE "E" APPEARS AS FIVE HORIZONTAL LINES, THE "G" RESEMBLES A POWER BUTTON ROTATED 90 DEGREES TO THE RIGHT, AND THE "O" INCLUDES A TRIANGLE INSIDE TO RESEMBLE A PLAY BUTTON. IN THE WORD "AUDIO", THE FIRST FOUR LETTERS ARE LOWER CASE AND THE "O" INCLUDES TWO VERTICAL LINES TO RESEMBLE A PAUSE BUTTON.

THE ENGLISH TRANSLATION OF "TEGO" IN THE MARK IS "HAVE".

FOR AUDIO CABLES; AUDIO HEADPHONES; AUDIO SPEAKERS (U.S. CLS. 21, 23, 26, 36 AND 38).

KATHERINE CHANG, EXAMINING ATTORNEY

SN 85-292,077. GENERAL ELECTRIC COMPANY, SCHENECTADY, NY. FILED 4-11-2011.

STATS OF THE UNION

THE MARK CONSISTS OF STANDARD CHARACTERS WITHOUT CLAIM TO ANY PARTICULAR FONT, STYLE, SIZE, OR COLOR.

FOR COMPUTER APPLICATION SOFTWARE FOR MOBILE PHONES, PORTABLE MEDIA PLAYERS, HANDHELD COMPUTERS, NAMELY, SOFTWARE FOR COLLECTING, STORING, AND DISPLAYING DATA, RELATING TO HEALTHCARE (U.S. CLS. 21, 23, 26, 36 AND 38).

MICHAEL SOUDERS, EXAMINING ATTORNEY

CLASS 9—(Continued).

SN 85-292,268. CENTER FOR CULTURAL AND TECHNICAL INTERCHANGE BETWEEN EAST AND WEST, INC., HONOLULU, HI. FILED 4-11-2011.



OWNER OF U.S. REG. NO. 1,679,210.
THE MARK CONSISTS OF A FANCIFUL DESIGN THAT IS FORMED USING THE CAPITAL LETTERS "E" AND "W". FOR PRERECORDED CDS AND DVDS FEATURING ACADEMIC, CULTURAL, POLITICAL AND INSTRUCTIONAL MATERIAL PERTAINING TO THE ASIA-PACIFIC REGION AND THE UNITED STATES (U.S. CLS. 21, 23, 26, 36 AND 38).
FIRST USE 1-9-2010; IN COMMERCE 1-9-2010.
LAURIE KAUFMAN, EXAMINING ATTORNEY

SN 85-292,282. TASTAQ INC., RENO, NV. FILED 4-11-2011.

CLOCKONIZER

THE MARK CONSISTS OF STANDARD CHARACTERS WITHOUT CLAIM TO ANY PARTICULAR FONT, STYLE, SIZE, OR COLOR.
FOR COMPUTER APPLICATION SOFTWARE FOR MOBILE SMART PHONES, CELLULAR PHONES, MOBILE PHONES AND TABLET PERSONAL COMPUTERS, NAMELY, SOFTWARE FOR USE IN DATABASE MANAGEMENT (U.S. CLS. 21, 23, 26, 36 AND 38).
WARREN L. OLANDRIA, EXAMINING ATTORNEY

SN 85-292,290. BLACK, ASHLEY, HOUSTON, TX. FILED 4-11-2011.

NeurOign

THE MARK CONSISTS OF STANDARD CHARACTERS WITHOUT CLAIM TO ANY PARTICULAR FONT, STYLE, SIZE, OR COLOR.
FOR DOWNLOADABLE VIDEO RECORDINGS FEATURING FITNESS INSTRUCTION (U.S. CLS. 21, 23, 26, 36 AND 38).
ALYSSA STEEL, EXAMINING ATTORNEY

CLASS 9—(Continued).

SN 85-292,316. NORTHWEST ANALYTICS, INC., PORTLAND, OR. FILED 4-11-2011.

**Manufacturing Intelligence
for Intelligent
Manufacturing**

THE MARK CONSISTS OF STANDARD CHARACTERS WITHOUT CLAIM TO ANY PARTICULAR FONT, STYLE, SIZE, OR COLOR.
FOR COMPUTER SOFTWARE FOR STATISTICAL PROCESS CONTROL AND QUALITY CONTROL IN THE MANUFACTURING, ENGINEERING AND SCIENTIFIC FIELDS AND FOR THE COLLECTION, ANALYSIS AND REPORTING OF MANUFACTURING DATA; COMPUTER SOFTWARE FOR STATISTICAL PROCESS CONTROL AND QUALITY CONTROL IN THE MANUFACTURING, ENGINEERING AND SCIENTIFIC FIELDS AND FOR THE COLLECTION, ANALYSIS AND REPORTING OF MANUFACTURING DATA THAT MAY BE DOWNLOADED FROM A GLOBAL COMPUTER NETWORK (U.S. CLS. 21, 23, 26, 36 AND 38).
MARK SPARACINO, EXAMINING ATTORNEY

SN 85-292,321. ACCESS VG, L.L.C., SALT LAKE CITY, UT. FILED 4-11-2011.

MY DEALS MOBILE

THE MARK CONSISTS OF STANDARD CHARACTERS WITHOUT CLAIM TO ANY PARTICULAR FONT, STYLE, SIZE, OR COLOR.
FOR DOWNLOADABLE SOFTWARE APPLICATION FOR USERS TO OBTAIN PROMOTIONAL DISCOUNTS, COUPONS, REBATES, OR SPECIAL OFFERINGS ON GOODS AND/OR SERVICES PROVIDED BY BUSINESS PARTNERS, NAMELY DINING, SHOPPING, HOTELS, CONDO RENTAL, TRAVEL, CAR RENTAL, GOLF, SKIING, MOVIES, HOME PRODUCTS, AND HEALTH AND BEAUTY PRODUCTS (U.S. CLS. 21, 23, 26, 36 AND 38).
FIRST USE 3-28-2011; IN COMMERCE 3-28-2011.
ZACHARY BELLO, EXAMINING ATTORNEY

CLASS 9—(Continued).

SN 85-292,339. Highbrow Games, LLC, AKA Highbrow Games, Redmond, WA. Filed 4-11-2011.

Highbrow Games

THE MARK CONSISTS OF STANDARD CHARACTERS WITHOUT CLAIM TO ANY PARTICULAR FONT, STYLE, SIZE, OR COLOR.

NO CLAIM IS MADE TO THE EXCLUSIVE RIGHT TO USE "GAMES", APART FROM THE MARK AS SHOWN.

FOR (BASED ON USE IN COMMERCE) COMPUTER GAME SOFTWARE FOR PERSONAL COMPUTERS AND HOME VIDEO GAME CONSOLES; (BASED ON INTENT TO USE) COMPUTER GAME SOFTWARE FOR USE ON MOBILE AND CELLULAR PHONES (U.S. CLS. 21, 23, 26, 36 AND 38).

FIRST USE 2-13-2009; IN COMMERCE 2-13-2009.
KIM SAITO, EXAMINING ATTORNEY

CLASS 9—(Continued).

SN 85-292,443. Stone Creek Entertainment Inc., Ridgefield, CT. Filed 4-12-2011.

KARIZMAC LUMINOUS

THE MARK CONSISTS OF STANDARD CHARACTERS WITHOUT CLAIM TO ANY PARTICULAR FONT, STYLE, SIZE, OR COLOR.

OWNER OF U.S. REG. NOS. 3,836,289, 3,941,108 AND OTHERS.

FOR DOWNLOADABLE VIDEO GAME SOFTWARE FOR MOBILE DEVICES AND PERSONAL COMPUTERS (U.S. CLS. 21, 23, 26, 36 AND 38).

NELSON SNYDER, EXAMINING ATTORNEY

SN 85-292,421. ADASA INC., EUGENE, OR. FILED 4-12-2011.

Veri-Real

THE MARK CONSISTS OF STANDARD CHARACTERS WITHOUT CLAIM TO ANY PARTICULAR FONT, STYLE, SIZE, OR COLOR.

FOR RADIO FREQUENCY IDENTIFICATION (RFID) TAGS (U.S. CLS. 21, 23, 26, 36 AND 38).

LOURDES AYALA, EXAMINING ATTORNEY

SN 85-292,523. B FIT, LLC, GRAND HAVEN, MI. FILED 4-12-2011.



THE MARK CONSISTS OF THE WORD "BEACHFIT" WHEREIN THE "B" COMPRISES A RUNNING FIGURE.

FOR DVDS FEATURING FITNESS EXERCISES AND ROUTINES (U.S. CLS. 21, 23, 26, 36 AND 38).

JORDAN BAKER, EXAMINING ATTORNEY

SN 85-292,423. ADASA INC., EUGENE, OR. FILED 4-12-2011.

Veri-Flip

THE MARK CONSISTS OF STANDARD CHARACTERS WITHOUT CLAIM TO ANY PARTICULAR FONT, STYLE, SIZE, OR COLOR.

FOR RADIO FREQUENCY IDENTIFICATION (RFID) TAGS (U.S. CLS. 21, 23, 26, 36 AND 38).

LOURDES AYALA, EXAMINING ATTORNEY

SN 85-292,571. GENERAL ELECTRIC COMPANY, SCHE-
NECTADY, NY. FILED 4-12-2011.

CORESCAN

THE MARK CONSISTS OF STANDARD CHARACTERS WITHOUT CLAIM TO ANY PARTICULAR FONT, STYLE, SIZE, OR COLOR.

FOR COMPUTER SOFTWARE FOR USE IN ANALYZING BODY FAT AND MEASURING THE BODY MASS OF A PATIENT (U.S. CLS. 21, 23, 26, 36 AND 38).

MICHAEL SOUDERS, EXAMINING ATTORNEY

CLASS 9—(Continued).

SN 85-292,580. STAR TRINITY, LLC, EL SEGUNDO, CA. FILED 4-12-2011.

BUTTR

THE MARK CONSISTS OF STANDARD CHARACTERS WITHOUT CLAIM TO ANY PARTICULAR FONT, STYLE, SIZE, OR COLOR.

FOR DOWNLOADABLE SOFTWARE IN THE NATURE OF A MOBILE APPLICATION FOR ASSISTANCE AND ADVICE WITH CLOTHING AND ACCESSORY FITTING AND SIZING (U.S. CLS. 21, 23, 26, 36 AND 38).

JASON BLAIR, EXAMINING ATTORNEY

SN 85-292,582. AM GENERAL LLC, SOUTH BEND, IN. FILED 4-12-2011.



THE MARK CONSISTS OF A DEPICTION OF A CONCH SEA SHELL.

FOR ARMOR FOR PROTECTING THE BODY, BUILDINGS AND OTHER STRUCTURES, AIRCRAFT, MARINE VESSELS AND VEHICLES AGAINST BALLISTIC PROJECTILES AND EXPLOSIVE FRAGMENTS (U.S. CLS. 21, 23, 26, 36 AND 38).

JASON BLAIR, EXAMINING ATTORNEY

SN 85-292,594. AM GENERAL LLC, SOUTH BEND, IN. FILED 4-12-2011.

CONCH

THE MARK CONSISTS OF STANDARD CHARACTERS WITHOUT CLAIM TO ANY PARTICULAR FONT, STYLE, SIZE, OR COLOR.

FOR ARMOR FOR PROTECTING THE BODY, BUILDINGS AND OTHER STRUCTURES, AIRCRAFT, MARINE VESSELS AND VEHICLES AGAINST BALLISTIC PROJECTILES AND EXPLOSIVE FRAGMENTS (U.S. CLS. 21, 23, 26, 36 AND 38).

JASON BLAIR, EXAMINING ATTORNEY

CLASS 9—(Continued).

SN 85-292,605. GENERAL ELECTRIC COMPANY, SCHENECTADY, NY. FILED 4-12-2011.

COREScore

THE MARK CONSISTS OF STANDARD CHARACTERS WITHOUT CLAIM TO ANY PARTICULAR FONT, STYLE, SIZE, OR COLOR.

FOR COMPUTER SOFTWARE FOR USE IN ANALYZING BODY FAT AND MEASURING THE BODY MASS OF A PATIENT (U.S. CLS. 21, 23, 26, 36 AND 38).

MICHAEL SOUDERS, EXAMINING ATTORNEY

SN 85-292,612. BARRETT NEWTON INC., ST. CHARLES, MO. FILED 4-12-2011.

CartThrob

THE MARK CONSISTS OF STANDARD CHARACTERS WITHOUT CLAIM TO ANY PARTICULAR FONT, STYLE, SIZE, OR COLOR.

FOR COMPUTER SOFTWARE, NAMELY, ELECTRONIC FINANCIAL PLATFORM THAT ACCOMMODATES MULTIPLE TYPES OF PAYMENT AND DEBT TRANSACTIONS IN AN INTEGRATED MOBILE PHONE, PDA, AND WEB BASED ENVIRONMENT (U.S. CLS. 21, 23, 26, 36 AND 38).

FIRST USE 9-22-2009; IN COMMERCE 4-8-2010.

AMY HELLA, EXAMINING ATTORNEY

SN 85-292,661. JSC "REALORE", KPAIPEDA, LITHUANIA, FILED 4-12-2011.

ROADS OF ROME

THE MARK CONSISTS OF STANDARD CHARACTERS WITHOUT CLAIM TO ANY PARTICULAR FONT, STYLE, SIZE, OR COLOR.

FOR COMPUTER GAME PROGRAMS; DOWNLOADABLE COMPUTER GAME PROGRAMS; DOWNLOADABLE ELECTRONIC GAME PROGRAMS; ELECTRONIC GAME PROGRAMS; ELECTRONIC GAME SOFTWARE; INTERACTIVE GAME SOFTWARE; INTERACTIVE MULTIMEDIA COMPUTER GAME PROGRAM; INTERACTIVE VIDEO GAME PROGRAMS (U.S. CLS. 21, 23, 26, 36 AND 38).

FIRST USE 10-0-2010; IN COMMERCE 10-0-2010.

JOHN GARTNER, EXAMINING ATTORNEY

CLASS 9—(Continued).

SN 85-292,673. TROIANI, DARIO, CHARLESTON, SC. FILED 4-12-2011.

SANDOKAN

THE MARK CONSISTS OF STANDARD CHARACTERS WITHOUT CLAIM TO ANY PARTICULAR FONT, STYLE, SIZE, OR COLOR.

FOR AUDIO AND VIDEO RECORDINGS FEATURING FICTIONAL CHARACTERS IN LIVE-ACTION OR ANIMATED COMIC, DRAMATIC, FANTASY, HORROR, ACTION AND ADVENTURE STORIES; AUDIO BOOKS IN THE FIELD OF FICTIONAL CHARACTERS IN COMIC, DRAMATIC, FANTASY, HORROR, ACTION AND ADVENTURE STORIES; AUDIO BOOKS IN THE NATURE OF NOVELS; AUDIO DIGITAL TAPES FEATURING FICTIONAL CHARACTERS IN LIVE-ACTION OR ANIMATED COMIC, DRAMATIC, FANTASY, HORROR, ACTION AND ADVENTURE STORIES; CHILDREN'S VIDEO TAPES; COMPUTER GAME CARTRIDGES AND DISCS; COMPUTER GAME CASSETTES; COMPUTER GAME CONSOLES FOR USE WITH AN EXTERNAL DISPLAY SCREEN OR MONITOR; COMPUTER GAME DISCS; COMPUTER GAME EQUIPMENT, NAMELY, DISCS; COMPUTER GAME JOYSTICKS; COMPUTER GAME PROGRAMMES; COMPUTER GAME PROGRAMMES DOWNLOADABLE VIA THE INTERNET; COMPUTER GAME PROGRAMS, CARTRIDGES, AND CASSETTES; COMPUTER GAME SOFTWARE; COMPUTER GAME SOFTWARE DOWNLOADABLE FROM A GLOBAL COMPUTER NETWORK; COMPUTER GAME SOFTWARE FOR PERSONAL COMPUTERS AND HOME VIDEO GAME CONSOLES; COMPUTER GAME SOFTWARE FOR USE ON MOBILE AND CELLULAR PHONES; COMPUTER GAME SOFTWARE FOR USE WITH PERSONAL COMPUTERS, HOME VIDEO GAME CONSOLES USED WITH TELEVISIONS AND ARCADE-BASED VIDEO GAME CONSOLES; DIGITAL MEDIA, NAMELY, PRE-RECORDED DVDS, DOWNLOADABLE AUDIO AND VIDEO RECORDINGS, AND CDS FEATURING AND PROMOTING FICTIONAL CHARACTERS IN LIVE-ACTION OR ANIMATED COMIC, DRAMATIC, FANTASY, HORROR, ACTION AND ADVENTURE STORIES; DIGITAL MEDIA, NAMELY, PRE-RECORDED VIDEO CASSETTES, DIGITAL VIDEO DISCS, DIGITAL VERSATILE DISCS, DOWNLOADABLE AUDIO AND VIDEO RECORDINGS, DVDS, AND HIGH DEFINITION DIGITAL DISCS FEATURING FICTIONAL CHARACTERS IN LIVE-ACTION OR ANIMATED COMIC, DRAMATIC, FANTASY, HORROR, ACTION AND ADVENTURE STORIES; DOWNLOADABLE COMPUTER GAME PROGRAMS; DOWNLOADABLE COMPUTER GAME SOFTWARE VIA A GLOBAL COMPUTER NETWORK AND WIRELESS DEVICES; DOWNLOADABLE COMPUTER PROGRAMS FEATURING POSITIONABLE GAME PIECE FIGURES FOR USE IN THE FIELD OF COMPUTER GAMES; DOWNLOADABLE ELECTRONIC GAME PROGRAMS; DOWNLOADABLE ELECTRONIC PUBLICATIONS IN THE NATURE OF BOOKS, SHORT STORIES, COMIC BOOKS, GRAPHIC NOVELS, MAGAZINES, NEWS ARTICLES, NEWSLETTERS AND ESSAYS IN THE FIELD OF FICTIONAL CHARACTERS IN LIVE-ACTION OR ANIMATED COMIC, DRAMATIC, FANTASY, HORROR, ACTION AND ADVENTURE STORIES; DOWNLOADABLE FILMS AND TELEVISION PROGRAMS FEATURING FICTIONAL CHARACTERS IN LIVE-ACTION OR ANIMATED COMIC, DRAMATIC, FANTASY, HORROR, ACTION AND ADVENTURE STORIES PROVIDED VIA A VIDEO-ON-DEMAND SERVICE; DOWNLOADABLE IMAGE FILES CONTAINING LIVE ACTION OR ANIMATED MOTION PICTURES, VIDEOS AND TELEVISION SHOWS FEATURING FICTIONAL CHARACTERS IN COMIC, DRAMATIC, FANTASY, HORROR, ACTION AND ADVENTURE STORIES; DOWNLOADABLE MOTION PICTURES AND TELEVISION SHOWS ABOUT FICTIONAL CHARACTERS IN LIVE-ACTION OR ANIMATED COMIC, DRAMATIC, FANTASY, HORROR, ACTION AND ADVENTURE

CLASS 9—(Continued).

STORIES; DOWNLOADABLE MP3 FILES AND MP3 RECORDINGS FEATURING ANIMATION, LIVE-ACTION ENTERTAINMENT, MUSIC, STORIES AND GAMES; DOWNLOADABLE MULTIMEDIA FILE CONTAINING ARTWORK, TEXT, AUDIO, VIDEO, GAMES, AND INTERNET WEB LINKS RELATING TO FICTIONAL CHARACTERS IN LIVE-ACTION OR ANIMATED COMIC, DRAMATIC, FANTASY, HORROR, ACTION AND ADVENTURE STORIES; DOWNLOADABLE MUSICAL SOUND RECORDINGS; DOWNLOADABLE RING TONES, GRAPHICS AND MUSIC VIA A GLOBAL COMPUTER NETWORK AND WIRELESS DEVICES; DOWNLOADABLE VIDEO RECORDINGS FEATURING ANIMATION, LIVE-ACTION ENTERTAINMENT, MUSIC, STORIES AND GAMES; ELECTRONIC GAME PROGRAMS; ELECTRONIC GAME SOFTWARE; ELECTRONIC GAME SOFTWARE FOR CELLULAR TELEPHONES; ELECTRONIC GAME SOFTWARE FOR HANDHELD ELECTRONIC DEVICES; ELECTRONIC GAME SOFTWARE FOR WIRELESS DEVICES; INTERACTIVE MUSIC MANUSCRIPT IN MULTIMEDIA VIDEO GAME FORMAT DISTRIBUTED AS DOWNLOADABLE OR DIGITAL MEDIA; MOTION PICTURE FILMS ABOUT FICTIONAL CHARACTERS IN LIVE-ACTION OR ANIMATED COMIC, DRAMATIC, FANTASY, HORROR, ACTION AND ADVENTURE STORIES; MOTION PICTURE FILMS AND FILMS FOR TELEVISION FEATURING CHILDREN'S ENTERTAINMENT; PRERECORDED AUDIO TAPES FEATURING FICTIONAL CHARACTERS IN LIVE-ACTION OR ANIMATED COMIC, DRAMATIC, FANTASY, HORROR, ACTION AND ADVENTURE STORIES; VIDEO GAME CONSOLES FOR USE WITH AN EXTERNAL DISPLAY SCREEN OR MONITOR; VIDEO GAME INTERACTIVE CONTROL FLOOR PADS OR MATS; VIDEO GAME INTERACTIVE HAND HELD REMOTE CONTROLS FOR PLAYING ELECTRONIC GAMES; VIDEO GAME INTERACTIVE REMOTE CONTROL UNITS; VIDEO GAME JOYSTICKS; VIDEO GAME MACHINES FOR USE WITH EXTERNAL DISPLAY SCREEN OR MONITOR; VIDEO GAME MACHINES FOR USE WITH TELEVISIONS; VIDEO GAME SOFTWARE; VIDEO MAGAZINE RECORDED ON ELECTRONIC MEDIA FEATURING FICTIONAL CHARACTERS IN LIVE-ACTION OR ANIMATED COMIC, DRAMATIC, FANTASY, HORROR, ACTION AND ADVENTURE STORIES; VIDEO OUTPUT GAME MACHINES FOR USE WITH EXTERNAL DISPLAY SCREEN OR MONITOR; VIRTUAL REALITY GAME SOFTWARE; WIRELESS COMMUNICATION DEVICE FEATURING VOICE, DATA AND IMAGE TRANSMISSION INCLUDING VOICE, TEXT AND PICTURE MESSAGING, A VIDEO AND STILL IMAGE CAMERA, ALSO FUNCTIONAL TO PURCHASE MUSIC, GAMES, VIDEO AND SOFTWARE APPLICATIONS OVER THE AIR FOR DOWNLOADING TO THE DEVICE (U.S. CLS. 21, 23, 26, 36 AND 38).

RONALD MCMORROW, EXAMINING ATTORNEY

SN 85-292,677. DIVERSIFIED POWER INTERNATIONAL, LLC, PINEY FLATS, TN. FILED 4-12-2011.

ONE-2-ALL

THE MARK CONSISTS OF STANDARD CHARACTERS WITHOUT CLAIM TO ANY PARTICULAR FONT, STYLE, SIZE, OR COLOR.

FOR BATTERY CABLES; CABLE CONNECTORS; CABLES, ELECTRIC; ELECTRICAL INTERCONNECT CABLES (U.S. CLS. 21, 23, 26, 36 AND 38).

FIRST USE 3-1-2010; IN COMMERCE 3-1-2010.
STEVEN JACKSON, EXAMINING ATTORNEY

CLASS 9—(Continued).

SN 85-292,873. GRENIER, ERIC, PARKER, CO. FILED 4-12-2011.

PINNY

THE MARK CONSISTS OF STANDARD CHARACTERS WITHOUT CLAIM TO ANY PARTICULAR FONT, STYLE, SIZE, OR COLOR.

FOR COMPUTER APPLICATION SOFTWARE FOR MOBILE PHONES OR COMPUTERS, NAMELY, SOFTWARE FOR USE IN THE INTEGRATION OF GEOGRAPHIC INFORMATION SYSTEMS (GIS), SOCIAL NETWORKING AND MOBILE COUPONS (U.S. CLS. 21, 23, 26, 36 AND 38).

JILL C. ALT, EXAMINING ATTORNEY

SN 85-292,904. MIGRANT STUDIOS, TAMPA, FL. FILED 4-12-2011.

Scorched Earth

THE MARK CONSISTS OF STANDARD CHARACTERS WITHOUT CLAIM TO ANY PARTICULAR FONT, STYLE, SIZE, OR COLOR.

FOR COMPUTER APPLICATION SOFTWARE FOR MOBILE PHONES AND HANDHELD COMPUTERS, NAMELY, SOFTWARE FOR GAME PLAYING, NAMELY, TURN-BASED GAME PLAY SIMULATING ARTILLERY COMBAT OF MULTIPLE PLAYERS IN A DESTRUCTIBLE ENVIRONMENT (U.S. CLS. 21, 23, 26, 36 AND 38).

FIRST USE 9-28-2009; IN COMMERCE 9-28-2009.
HAI-LY LAM, EXAMINING ATTORNEY

SN 85-293,012. BEE-LINE COMMUNICATIONS, LIBERTY-VILLE, IL. FILED 4-12-2011.

SKOSH

THE COLOR(S) BLACK AND ORANGE IS/ARE CLAIMED AS A FEATURE OF THE MARK.

THE MARK CONSISTS OF THE WORD SKOSH IN ALL CAPITAL LETTERS. ALL LETTERS EXCEPT THE O ARE BLACK. THE LETTER O, THE GRAPHIC ELEMENT OF THE MARK, IS ORANGE AND IS A SLIGHTLY LARGER TYPE SIZE WITH THE DIACRITICAL MARK, KNOWN AS A MACRON (INDICATING A LONG VOWEL SOUND), SHOWN AS A HORIZONTAL LINE OVER THE LETTER O.

FOR COMPUTER STYLUS; INSTRUMENT TO FACILITATE TEXT-MESSAGING IN THE NATURE OF A STYLUS-TYPE DEVICE THAT IS ATTACHED TO THE HAND FOR USE IN CONJUNCTION WITH PERSONAL DIGITAL ASSISTANTS (U.S. CLS. 21, 23, 26, 36 AND 38).

FIRST USE 12-23-2010; IN COMMERCE 12-23-2010.
CURTIS FRENCH, EXAMINING ATTORNEY

CLASS 9—(Continued).

SN 85-293,081. TWO BROTHERS RACING, INC., SANTA ANA, CA. FILED 4-12-2011.

ROKBED

THE MARK CONSISTS OF STANDARD CHARACTERS WITHOUT CLAIM TO ANY PARTICULAR FONT, STYLE, SIZE, OR COLOR.

FOR EARPHONES AND HEADPHONES; AUDIO SPEAKERS; BATTERY CHARGERS AND POWER ACCESSORIES, NAMELY, ADAPTORS, CAPACITORS, CONVERTERS, ELECTRICAL CELLS, AND COUPLERS, FOR ELECTRONIC DEVICES; PROTECTIVE COVERS FOR ELECTRONIC DEVICES, NAMELY, CELL PHONES, MP3 PLAYERS, TABLET COMPUTERS, PERSONAL MUSIC PLAYERS, HANDHELD COMPUTERS, HANDHELD GAMING DEVICES, LAPTOPS, AND MEDIA PLAYERS; PROTECTIVE CASES FOR ELECTRONIC DEVICES, NAMELY, CELL PHONES, MP3 PLAYERS, TABLET COMPUTERS, PERSONAL MUSIC PLAYERS, HANDHELD COMPUTERS, HANDHELD GAMING DEVICES, LAPTOPS, AND MEDIA PLAYERS; FITTED PLASTIC FILMS KNOWN AS SKINS FOR COVERING AND PROTECTING ELECTRONIC APPARATUS FOR ELECTRONIC APPARATUS, NAMELY, CELL PHONES, MP3 PLAYERS, TABLET COMPUTERS, PERSONAL MUSIC PLAYERS, HANDHELD COMPUTERS, HANDHELD GAMING DEVICES, LAPTOPS, AND MEDIA PLAYERS; FITTED PLASTIC FILMS KNOWN AS SKINS FOR COVERING AND PROTECTING ELECTRONIC APPARATUS, NAMELY, ELECTRONIC SCREENS; BAGS AND POUCHES SPECIFICALLY ADAPTED FOR HOLDING OR CARRYING ELECTRONIC DEVICES, NAMELY, CELL PHONES, MP3 PLAYERS, TABLET COMPUTERS, PERSONAL MUSIC PLAYERS, HANDHELD COMPUTERS, HANDHELD GAMING DEVICES, LAPTOPS, AND MEDIA PLAYERS; CASES AND CONTAINERS SPECIFICALLY ADAPTED FOR HOLDING OR CARRYING ELECTRONIC DEVICES, NAMELY, CELL PHONES, MP3 PLAYERS, TABLET COMPUTERS, PERSONAL MUSIC PLAYERS, HANDHELD COMPUTERS, HANDHELD GAMING DEVICES, LAPTOPS, AND MEDIA PLAYERS; PROTECTIVE SLEEVES AND ARMBANDS FOR ELECTRONIC DEVICES, NAMELY, CELL PHONES, MP3 PLAYERS, TABLET COMPUTERS, PERSONAL MUSIC PLAYERS, HANDHELD COMPUTERS, HANDHELD GAMING DEVICES, LAPTOPS, AND MEDIA PLAYERS; MEDIA PLAYERS; ELECTRIC CABLES; DIGITAL AUDIO COMPONENTS, NAMELY, PERSONAL RADIO AND VIDEO TUNERS AND TRANSMITTERS; ELECTRICAL AND ELECTRONIC CONNECTORS; MOBILE MEDIA DEVICE SOFTWARE AND APPLICATIONS FOR CREATING AND BUYING PROTECTIVE CASES; HOLDERS FOR ELECTRONIC DEVICES, NAMELY, CELL PHONES, MP3 PLAYERS, TABLET COMPUTERS, PERSONAL MUSIC PLAYERS, HANDHELD COMPUTERS, COMPUTER MONITORS, HANDHELD GAMING DEVICES, LAPTOPS, AND MEDIA PLAYERS FOR ELECTRONIC DEVICES (U.S. CLS. 21, 23, 26, 36 AND 38).

DORITT L. CARROLL, EXAMINING ATTORNEY

CLASS 9—(Continued).

SN 85-293,179. BVW HOLDINGS, LLC, OCEANSIDE, CA.
FILED 4-12-2011.



THE MARK CONSISTS OF THE LETTERS "TL" IN UPPER-CASE AND CENTERED WITHIN A CIRCLE SURROUNDING THE LETTERS. THE "T" IS LOCATED JUST LEFT OF CENTER WITHIN THE CIRCLE. THE TOP OF THE "L" IS POSITIONED JUST SLIGHTLY BELOW THE TOP CROSS OF THE "T" AND SLIGHTLY TO THE RIGHT. THE RIGHT EDGE OF THE BOTTOM LINE OF THE "L" ABUTS THE RIGHT ARC OF THE CIRCLE. THE LINES THAT MAKE UP THE "T" ARE SLIGHTLY WIDER AND LONGER THAN THOSE OF THE "L."

FOR AMPLIFIER FOR WIRELESS COMMUNICATIONS; AMPLIFIERS; AUDIO AMPLIFIERS; AUDIO CABLES; AUDIO CIRCUIT BOARDS; AUDIO ELECTRONIC COMPONENTS, NAMELY, SURROUND SOUND SYSTEMS; AUDIO RECORDERS; AUDIO SPEAKERS; MICROPHONE CABLES; MICROPHONE MODULES; MICROPHONES; MICROPHONES FOR COMMUNICATION DEVICES (U.S. CLS. 21, 23, 26, 36 AND 38).

LIEF MARTIN, EXAMINING ATTORNEY

SN 85-293,317. PAGEMANAGE, INC., CUPERTINO, CA.
FILED 4-12-2011.

RECOLLECT

THE MARK CONSISTS OF STANDARD CHARACTERS WITHOUT CLAIM TO ANY PARTICULAR FONT, STYLE, SIZE, OR COLOR.

FOR COMPUTER SOFTWARE PROGRAM FOR DOCUMENT STORAGE AND RETRIEVAL (U.S. CLS. 21, 23, 26, 36 AND 38).

FIRST USE 6-23-1992; IN COMMERCE 6-23-1992.
WON TEAK OH, EXAMINING ATTORNEY

CLASS 9—(Continued).

SN 85-293,350. SOUL AND VIBE ENTERTAINMENT, LLC,
SAINT MICHAEL, MN. FILED 4-12-2011.

Soul and Vibe

THE MARK CONSISTS OF STANDARD CHARACTERS WITHOUT CLAIM TO ANY PARTICULAR FONT, STYLE, SIZE, OR COLOR.

FOR COMPUTER GAME CARTRIDGES; COMPUTER GAME CARTRIDGES AND DISCS; COMPUTER GAME CASSETTES; COMPUTER GAME DISCS; COMPUTER GAME EQUIPMENT, NAMELY, DISCS; COMPUTER GAME PROGRAMMES; COMPUTER GAME PROGRAMMES DOWNLOADABLE VIA THE INTERNET; COMPUTER GAME PROGRAMS; COMPUTER GAME PROGRAMS, CARTRIDGES, AND CASSETTES; COMPUTER GAME SOFTWARE; COMPUTER GAME SOFTWARE DOWNLOADABLE FROM A GLOBAL COMPUTER NETWORK; COMPUTER GAME SOFTWARE FOR PERSONAL COMPUTERS AND HOME VIDEO GAME CONSOLES; COMPUTER GAME SOFTWARE FOR USE ON MOBILE AND CELLULAR PHONES; COMPUTER GAME SOFTWARE FOR USE WITH PERSONAL COMPUTERS, HOME VIDEO GAME CONSOLES USED WITH TELEVISIONS AND ARCADE-BASED VIDEO GAME CONSOLES; COMPUTER GAME TAPES; COMPUTER PROGRAMS FOR VIDEO AND COMPUTER GAMES; COMPUTER SOFTWARE, NAMELY, GAME ENGINE SOFTWARE FOR VIDEO GAME DEVELOPMENT AND OPERATION; COMPUTER-GAMING SOFTWARE; DOWNLOADABLE COMPUTER GAME PROGRAMS; DOWNLOADABLE COMPUTER GAME SOFTWARE VIA A GLOBAL COMPUTER NETWORK AND WIRELESS DEVICES; DOWNLOADABLE COMPUTER PROGRAMS FEATURING POSITIONABLE GAME PIECE FIGURES FOR USE IN THE FIELD OF COMPUTER GAMES; INTERACTIVE MULTIMEDIA COMPUTER GAME PROGRAM; INTERACTIVE MUSIC MANUSCRIPT IN MULTIMEDIA VIDEO GAME FORMAT DISTRIBUTED AS DOWNLOADABLE OR DIGITAL MEDIA; INTERACTIVE VIDEO GAME PROGRAMS; RECONFIGURABLE CASINO AND LOTTERY GAMING EQUIPMENT, NAMELY, GAMING MACHINES AND OPERATIONAL COMPUTER GAME SOFTWARE THEREFOR; RECORDED COMPUTER GAME PROGRAMS; VIDEO AND COMPUTER GAME PROGRAMS; VIDEO GAME CARTRIDGES; VIDEO GAME CARTRIDGES AND CASSETTES; VIDEO GAME CARTRIDGES AND DISCS; VIDEO GAME DISCS; VIDEO GAME SOFTWARE (U.S. CLS. 21, 23, 26, 36 AND 38).

MEGHAN REINHART, EXAMINING ATTORNEY

CLASS 9—(Continued).

SN 85-293,357. EMOTIVA PROFESSIONAL SYSTEMS, LLC, FRANKLIN, TN. FILED 4-12-2011.

airmotiv

THE MARK CONSISTS OF THE WORD "AIRMOTIV" IN ITALICS.

FOR LOUDSPEAKERS, NAMELY POWERED STUDIO MONITORS DESIGNED FOR USE IN THE PROFESSIONAL AND CONSUMER AUDIO MARKETS (U.S. CLS. 21, 23, 26, 36 AND 38).

MICHAEL WEBSTER, EXAMINING ATTORNEY

CLASS 9—(Continued).

SN 85-293,603. WISE BYTES LLC, SAN ANTONIO, TX. FILED 4-13-2011.

WiseText

THE MARK CONSISTS OF STANDARD CHARACTERS WITHOUT CLAIM TO ANY PARTICULAR FONT, STYLE, SIZE, OR COLOR.

FOR COMPUTER APPLICATION SOFTWARE FOR MOBILE PHONES, NAMELY, SOFTWARE FOR ORGANIZING AND SENDING TEMPLATED TEXT MESSAGES (U.S. CLS. 21, 23, 26, 36 AND 38).

APRIL ROACH, EXAMINING ATTORNEY

SN 85-293,636. KYOCERA COMMUNICATIONS, INC., SAN DIEGO, CA. FILED 4-13-2011.

SN 85-293,501. MOBILE CONTENT VENTURE LLC, NEW YORK, NY. FILED 4-12-2011.

DYLE

THE MARK CONSISTS OF STANDARD CHARACTERS WITHOUT CLAIM TO ANY PARTICULAR FONT, STYLE, SIZE, OR COLOR.

FOR COMPUTER HARDWARE AND SOFTWARE PROGRAMS FOR RECEIVING, PROCESSING, TRANSMITTING, DISPLAYING, MANIPULATING, AND RECORDING AUDIO, VISUAL, AND AUDIO-VISUAL CONTENT DELIVERED ACROSS MULTIPLE NETWORK INFRASTRUCTURES AND COMMUNICATIONS PROTOCOLS; DOWNLOADABLE AUDIO, VISUAL, AND AUDIO-VISUAL CONTENT IN THE FIELDS OF CURRENT EVENTS REPORTING, ENTERTAINMENT, SPORTS, WEATHER, COMEDY, DRAMA, DOCUMENTARIES, ACTION, ADVENTURE, MUSIC, AND MUSIC VIDEOS; ELECTRONIC PUBLICATIONS, NAMELY, BOOKS, MAGAZINES, MANUALS AND PAMPHLETS FEATURING ENTERTAINMENT, NEWS, MUSIC, TECHNOLOGY, WEATHER, SPORTS AND THE ARTS RECORDED ON COMPUTER MEDIA; DOWNLOADABLE MUSIC AND ELECTRONIC GAMES; INTERACTIVE GAMES, NAMELY, COMPUTER AND VIDEO GAME PROGRAMS FEATURING VIDEO CONTENT FROM MOTION PICTURES, TELEVISION PROGRAMMING, OR MUSIC VIDEOS (U.S. CLS. 21, 23, 26, 36 AND 38).

DOUGLAS LEE, EXAMINING ATTORNEY

ELLO

THE MARK CONSISTS OF STANDARD CHARACTERS WITHOUT CLAIM TO ANY PARTICULAR FONT, STYLE, SIZE, OR COLOR.

FOR CELL PHONES; CELLULAR PHONES; MOBILE PHONES (U.S. CLS. 21, 23, 26, 36 AND 38).

IRA J. GOODSaid, EXAMINING ATTORNEY

SN 85-293,641. KYOCERA COMMUNICATIONS, INC., SAN DIEGO, CA. FILED 4-13-2011.

DURO

THE MARK CONSISTS OF STANDARD CHARACTERS WITHOUT CLAIM TO ANY PARTICULAR FONT, STYLE, SIZE, OR COLOR.

FOR CELL PHONES; CELLULAR PHONES; MOBILE PHONES (U.S. CLS. 21, 23, 26, 36 AND 38).

IRA J. GOODSaid, EXAMINING ATTORNEY

CLASS 9—(Continued).

SN 85-293,658. BONGIOVI ACOUTICS, LLC, PORT ST. LUCIE, FL. FILED 4-13-2011.

The new audio standard for
your new media world

THE MARK CONSISTS OF STANDARD CHARACTERS WITHOUT CLAIM TO ANY PARTICULAR FONT, STYLE, SIZE, OR COLOR.

FOR COMPUTER SOFTWARE THAT ENHANCES THE AUDIO SOUND QUALITY ON COMPUTER SYSTEMS, DIGITAL SIGNAL PROCESSORS, DIGITAL STEREO EQUIPMENT, DIGITAL HOME THEATERS SYSTEMS AND OTHER CONSUMER ELECTRONICS THAT CONTAIN DIGITAL SIGNAL PROCESSING (U.S. CLS. 21, 23, 26, 36 AND 38).

LINDSEY RUBIN, EXAMINING ATTORNEY

SN 85-293,662. ALCATEL-LUCENT USA INC., MURRAY HILL, NJ. FILED 4-13-2011.

VITALNET

THE MARK CONSISTS OF STANDARD CHARACTERS WITHOUT CLAIM TO ANY PARTICULAR FONT, STYLE, SIZE, OR COLOR.

FOR COMPUTER SOFTWARE FOR NETWORK PERFORMANCE MANAGEMENT (U.S. CLS. 21, 23, 26, 36 AND 38).

GEOFFREY FOSDICK, EXAMINING ATTORNEY

SN 85-293,730. TSM CORPORATION, BARTLETT, TN. FILED 4-13-2011.

miniFIDES

THE MARK CONSISTS OF STANDARD CHARACTERS WITHOUT CLAIM TO ANY PARTICULAR FONT, STYLE, SIZE, OR COLOR.

FOR FIRE EXTINGUISHING APPARATUS (U.S. CLS. 21, 23, 26, 36 AND 38).

GEORGE LORENZO, EXAMINING ATTORNEY

CLASS 9—(Continued).

SN 85-293,920. CRAYONPIXEL, INC., GLENDALE, CA. FILED 4-13-2011.

CRAYONPIXEL

THE MARK CONSISTS OF STANDARD CHARACTERS WITHOUT CLAIM TO ANY PARTICULAR FONT, STYLE, SIZE, OR COLOR.

FOR ELECTRONIC GAME SOFTWARE FOR WIRELESS DEVICES; DOWNLOADABLE COMPUTER GAME PROGRAMS (U.S. CLS. 21, 23, 26, 36 AND 38).

THEODORE MCBRIDE, EXAMINING ATTORNEY

SN 85-293,983. SPEEDWARE INC., SAINT-LAURENT, QUEBEC, CANADA, FILED 4-13-2011.

DBMOTION

THE MARK CONSISTS OF STANDARD CHARACTERS WITHOUT CLAIM TO ANY PARTICULAR FONT, STYLE, SIZE, OR COLOR.

FOR COMPUTER SOFTWARE FOR MIGRATING DATABASES; DOWNLOADABLE SOFTWARE FOR MIGRATING DATABASES (U.S. CLS. 21, 23, 26, 36 AND 38).

FIRST USE 12-1-2002; IN COMMERCE 12-1-2002.

GINA HAYES, EXAMINING ATTORNEY

SN 85-294,055. GUARDITY TECHNOLOGIES, INC., PLANO, TX. FILED 4-13-2011.



ANGEL GUARD

THE MARK CONSISTS OF THE WORDING "ANGEL-GUARD" IN ALL-CAPITAL LETTERS WITH THE "A" IN "ANGEL" AND THE "G" IN "GUARD" OF A LARGER FONT THAN THE OTHER LETTERS. ADDITIONALLY, A PAIR OF WINGS EXTEND OUTWARD HORIZONTALLY FROM THE UPPER PORTION OF THE "A" IN "ANGEL".

FOR EMERGENCY NOTIFICATION SYSTEM COMPRISED OF A DATA PROCESSOR AND A USER INPUT DEVICE FOR CONNECTING THE DATA PROCESSOR TO AN EMERGENCY RESPONSE ENTITY THROUGH A COMMUNICATION NETWORK AND ALLOWING AUDIO AND DATA COMMUNICATION BETWEEN THE PROCESSOR AND THE ENTITY (U.S. CLS. 21, 23, 26, 36 AND 38).

LINDSEY RUBIN, EXAMINING ATTORNEY

CLASS 9—(Continued).

SN 85-294,106. TAPSY, INC., ORLANDO, FL. FILED 4-13-2011.



FOR COMPUTER GAME SOFTWARE; COMPUTER GAME SOFTWARE FOR USE ON MOBILE AND CELLULAR PHONES; VIDEO GAME SOFTWARE (U.S. CLS. 21, 23, 26, 36 AND 38).

FIRST USE 1-15-2011; IN COMMERCE 1-15-2011,
SETH A. RAPPAPORT, EXAMINING ATTORNEY

CLASS 9—(Continued).

SN 85-294,565. IGT, RENO, NV. FILED 4-13-2011.



THE MARK CONSISTS OF STANDARD CHARACTERS WITHOUT CLAIM TO ANY PARTICULAR FONT, STYLE, SIZE, OR COLOR.

FOR GAMING MACHINES, NAMELY, DEVICES WHICH ACCEPT A WAGER (U.S. CLS. 21, 23, 26, 36 AND 38).

CARYN GLASSER, EXAMINING ATTORNEY

SN 85-294,222. LEEK WILLIAM F, DBA SLEEK PRODUCTS, CARMEL, CA. FILED 4-13-2011.



THE MARK CONSISTS OF STANDARD CHARACTERS WITHOUT CLAIM TO ANY PARTICULAR FONT, STYLE, SIZE, OR COLOR.

FOR BREATHING APPARATUS FOR UNDERWATER SWIMMING (U.S. CLS. 21, 23, 26, 36 AND 38).

GIANCARLO CASTRO, EXAMINING ATTORNEY

SN 85-294,611. HALL, ERIC M. MOUNTAIN VIEW, CA. AND TAYLOR, AMIT M, SAN FRANCISCO, CA. FILED 4-13-2011.



THE MARK CONSISTS OF STANDARD CHARACTERS WITHOUT CLAIM TO ANY PARTICULAR FONT, STYLE, SIZE, OR COLOR.

FOR COMPUTER SOFTWARE FOR USE WITH MOBILE DEVICES THAT WILL ALLOW USERS TO RECEIVE INFORMATION PERTAINING TO THEIR GEOGRAPHIC LOCATION; COMPUTER SOFTWARE TO ALLOW BUSINESSES TO DO TRANSACTIONS WITH CONSUMERS (U.S. CLS. 21, 23, 26, 36 AND 38).

ALEX KEAM, EXAMINING ATTORNEY

SN 85-294,490. VIZIO, INC., IRVINE, CA. FILED 4-13-2011.



THE MARK CONSISTS OF STANDARD CHARACTERS WITHOUT CLAIM TO ANY PARTICULAR FONT, STYLE, SIZE, OR COLOR.

OWNER OF U.S. REG. NOS. 3,235,417 AND 3,835,959.

THE ENGLISH TRANSLATION OF "VIZIO" IN THE MARK IS "FLAW, MISTAKE, ERROR, FAULTS."

FOR LIQUID CRYSTAL DISPLAY TELEVISIONS; HIGH DEFINITION DVD PLAYERS; PORTABLE MEDIA PLAYERS; PORTABLE MEDIA PLAYER DOCKING STATIONS; HANDHELD COMPUTERS; MOBILE PHONES; HOME THEATER SYSTEMS COMPRISING AUDIO RECEIVERS AND AUDIO SPEAKERS; AUDIO SPEAKERS; AUDIO SPEAKERS IN THE NATURE OF SPEAKER BARS; WIRELESS ROUTERS; REMOTE CONTROLS FOR TELEVISIONS AND AUDIO EQUIPMENT; STEREOSCOPIC LENSES FOR 3D CONTENT VIEWING, NAMELY, ACTIVE 3D GLASSES, PASSIVE 3D GLASSES, AND VIRTUAL REALITY GLASSES; HIGH DEFINITION MULTIMEDIA INTERFACE CABLES; STEREO HEADPHONES (U.S. CLS. 21, 23, 26, 36 AND 38).

FIRST USE 3-31-2004; IN COMMERCE 3-31-2004.

ADA HAN, EXAMINING ATTORNEY

SN 85-294,614. MCCORKENDALE, VICKIE, MANHATTAN BEACH, CA. FILED 4-13-2011.



THE MARK CONSISTS OF STANDARD CHARACTERS WITHOUT CLAIM TO ANY PARTICULAR FONT, STYLE, SIZE, OR COLOR.

THE ENGLISH TRANSLATION OF "QUESO" AND "BESO" IN THE MARK IS "CHEESE" AND "KISS".

FOR COMPUTER APPLICATION SOFTWARE FOR MOBILE PHONES, NAMELY, SOFTWARE FOR AN ELECTRONIC DATABASE FEATURING INFORMATION ON CHEESE (U.S. CLS. 21, 23, 26, 36 AND 38).

EMILY CHUO, EXAMINING ATTORNEY

CLASS 9—(Continued).

SN 85-294,624. KATINKAS USA, WEST VALLEY CITY, UT.
FILED 4-13-2011.

Katinkas

THE MARK CONSISTS OF STANDARD CHARACTERS WITHOUT CLAIM TO ANY PARTICULAR FONT, STYLE, SIZE, OR COLOR.

FOR PROTECTIVE COVERS AND CASES FOR CELL PHONES, LAPTOPS AND PORTABLE MEDIA PLAYERS (U.S. CLS. 21, 23, 26, 36 AND 38).

FIRST USE 2-11-2011; IN COMMERCE 2-11-2011.

EMILY CHUO, EXAMINING ATTORNEY

SN 85-294,745. TRITON BEAUTY PRODUCTS, INC., SANTA FE SPRINGS, CA. FILED 4-14-2011.

NXTYLE

THE MARK CONSISTS OF STANDARD CHARACTERS WITHOUT CLAIM TO ANY PARTICULAR FONT, STYLE, SIZE, OR COLOR.

FOR ELECTRIC FLAT IRONS (U.S. CLS. 21, 23, 26, 36 AND 38).

FIRST USE 8-1-2008; IN COMMERCE 8-1-2008.

ALYSSA STEEL, EXAMINING ATTORNEY

SN 85-294,862. MIDCURRENT, LLC, FORT COLLINS, CO.
FILED 4-14-2011.

MIDCURRENT

THE MARK CONSISTS OF STANDARD CHARACTERS WITHOUT CLAIM TO ANY PARTICULAR FONT, STYLE, SIZE, OR COLOR.

OWNER OF U.S. REG. NO. 3,209,179.

FOR DOWNLOADABLE COMPUTER SOFTWARE FEATURING INFORMATION ON THE SUBJECT OF FLY FISHING; MOBILE PHONE APPLICATION SOFTWARE FEATURING INFORMATION ON THE SUBJECT OF FLY FISHING; DVDS AND VIDEOS FEATURING INFORMATION ON THE SUBJECT OF FLY FISHING (U.S. CLS. 21, 23, 26, 36 AND 38).

EMILY CHUO, EXAMINING ATTORNEY

CLASS 9—(Continued).

SN 85-294,919. AM TECHNOLOGIES, INC., NEWTON, MA.
FILED 4-14-2011.

WHY TYPE WHEN YOU CAN TALK

THE MARK CONSISTS OF STANDARD CHARACTERS WITHOUT CLAIM TO ANY PARTICULAR FONT, STYLE, SIZE, OR COLOR.

FOR COMPUTER SOFTWARE FOR SPEECH RECOGNITION, SPEECH ACTIVATION, AND SPEECH TRANSLATION, AND COMPUTER SYSTEM COMPRISING A CPU, INPUT DEVICE AND OUTPUT DEVICE (U.S. CLS. 21, 23, 26, 36 AND 38).

FIRST USE 9-1-1994; IN COMMERCE 9-1-1994.

ANDREA HACK, EXAMINING ATTORNEY

SN 85-294,926. SHINING TECHNOLOGY, INC., CYPRESS, CA. FILED 4-14-2011.

MNEME

THE MARK CONSISTS OF STANDARD CHARACTERS WITHOUT CLAIM TO ANY PARTICULAR FONT, STYLE, SIZE, OR COLOR.

FOR BLANK DIGITAL STORAGE MEDIA (U.S. CLS. 21, 23, 26, 36 AND 38).

PAM WILLIS, EXAMINING ATTORNEY

SN 85-294,944. NORTH AMERICAN BLUE TIGER COMPANY LLC, DALLAS, TX. FILED 4-14-2011.

Blue Tiger

THE MARK CONSISTS OF STANDARD CHARACTERS WITHOUT CLAIM TO ANY PARTICULAR FONT, STYLE, SIZE, OR COLOR.

FOR DEVICES FOR HANDS-FREE USE OF MOBILE PHONES (U.S. CLS. 21, 23, 26, 36 AND 38).

FIRST USE 8-1-2010; IN COMMERCE 9-1-2010.

DAVID H. STINE, EXAMINING ATTORNEY

CLASS 9—(Continued).

SN 85-295,064. ALEX IS THE BEST, LLC, BROOKLYN, NY. FILED 4-14-2011.

SAY CHEESE

THE MARK CONSISTS OF STANDARD CHARACTERS WITHOUT CLAIM TO ANY PARTICULAR FONT, STYLE, SIZE, OR COLOR.

FOR DOWNLOADABLE SOFTWARE IN THE NATURE OF A MOBILE APPLICATION FOR SHARING IMAGES, VIDEOS, MULTIMEDIA, LIVE VIDEOS FROM MOBILE DEVICES, NAMELY, CELL PHONES, NETWORK-ENABLED PORTABLE DEVICES AND CAMERA-ENABLED DEVICES, OVER A COMMUNICATIONS NETWORK; DOWNLOADABLE SOFTWARE IN THE NATURE OF A MOBILE APPLICATION FOR SHARING IMAGES, VIDEOS, MULTIMEDIA, LIVE VIDEOS FROM MOBILE DEVICES VIA TRUNCATED DOMAIN ADDRESSES AND URLS (U.S. CLS. 21, 23, 26, 36 AND 38).

EMILY CARLSEN, EXAMINING ATTORNEY

SN 85-295,148. OPTIMIZATION ZORN CORPORATION, DBA OZ SYSTEMS, ARLINGTON, TX. FILED 4-14-2011.

eREADI School+

FOR SOFTWARE FOR TRACKING EARLY EDUCATION PROGRAMS, STUDENT PERFORMANCE, AND SCHOOL READINESS (U.S. CLS. 21, 23, 26, 36 AND 38).

ELISSA GARBER KON, EXAMINING ATTORNEY

SN 85-295,160. LUMEN DYNAMICS GROUP INC., MISSISSAUGA, CANADA, FILED 4-14-2011.

X-CITE XLED

THE MARK CONSISTS OF STANDARD CHARACTERS WITHOUT CLAIM TO ANY PARTICULAR FONT, STYLE, SIZE, OR COLOR.

FOR MULTI-WAVELENGTH LED SOURCE USED FOR MICROSCOPE ILLUMINATION IN THE FIELD OF FLUORESCENCE CELLULAR IMAGING (U.S. CLS. 21, 23, 26, 36 AND 38).

JOHN HWANG, EXAMINING ATTORNEY

CLASS 9—(Continued).

SN 85-295,192. APOGEE DESIGN INC., DBA APOGEEINVENT, AMERICAN FALLS, ID. FILED 4-14-2011.

CobraCart

THE MARK CONSISTS OF STANDARD CHARACTERS WITHOUT CLAIM TO ANY PARTICULAR FONT, STYLE, SIZE, OR COLOR.

FOR COMPUTER E-COMMERCE SOFTWARE TO ALLOW USERS TO PERFORM ELECTRONIC BUSINESS TRANSACTIONS VIA A GLOBAL COMPUTER NETWORK (U.S. CLS. 21, 23, 26, 36 AND 38).

FIRST USE 3-10-2011; IN COMMERCE 3-10-2011.

MIDGE BUTLER, EXAMINING ATTORNEY

SN 85-295,348. RAXCO SOFTWARE, INC., GAITHERSBURG, MD. FILED 4-14-2011.

OptiWrite

THE MARK CONSISTS OF STANDARD CHARACTERS WITHOUT CLAIM TO ANY PARTICULAR FONT, STYLE, SIZE, OR COLOR.

FOR COMPUTER SOFTWARE DESIGNED TO INCREASE COMPUTER OPTIMIZATION, INCREASE DATA PROCESSING SPEED, ELIMINATE FRAGMENTATION; COMPUTER SOFTWARE DESIGNED TO MONITOR THE PERFORMANCE OF COMPUTER SYSTEMS AND INCREASE EFFICIENCY (U.S. CLS. 21, 23, 26, 36 AND 38).

ERNEST SHOSHO, EXAMINING ATTORNEY

SN 85-295,446. LUBIN, SETH D, WESTON, FL. FILED 4-14-2011.

JOIN THE BAND

THE MARK CONSISTS OF STANDARD CHARACTERS WITHOUT CLAIM TO ANY PARTICULAR FONT, STYLE, SIZE, OR COLOR.

FOR DOWNLOADABLE COMPUTER GAME SOFTWARE VIA A GLOBAL COMPUTER NETWORK AND WIRELESS DEVICES (U.S. CLS. 21, 23, 26, 36 AND 38).

BILL DAWE, EXAMINING ATTORNEY

CLASS 9—(Continued).

SN 85-295,470. WEBCETERA, L.P., FLOWER MOUND, TX. FILED 4-14-2011.

EZACCESS

THE MARK CONSISTS OF STANDARD CHARACTERS WITHOUT CLAIM TO ANY PARTICULAR FONT, STYLE, SIZE, OR COLOR.

FOR COMPUTER SOFTWARE, NAMELY, COMPUTER SOFTWARE FOR USER AUTHENTICATION, AUTHORIZATION AND LOGIN TO PROTECTED WEBSITE ACCOUNTS AND SECURE COMPUTER NETWORK RESOURCES (U.S. CLS. 21, 23, 26, 36 AND 38).

JOHN WILKE, EXAMINING ATTORNEY

CLASS 9—(Continued).

SN 85-295,746. GAUGE SCIENTIFIC, LLC, REDWOOD CITY, CA. FILED 4-14-2011.

GaugeSci

THE MARK CONSISTS OF STANDARD CHARACTERS WITHOUT CLAIM TO ANY PARTICULAR FONT, STYLE, SIZE, OR COLOR.

FOR ELECTRONIC-BASED INSTRUMENTS FOR MEASURING ENVIRONMENTAL PARAMETERS INCLUDING HUMIDITY, MOLD, BACTERIA, AIR QUALITY AND WATER QUALITY (U.S. CLS. 21, 23, 26, 36 AND 38).

ELISSA GARBER KON, EXAMINING ATTORNEY

SN 85-295,506. GRAVECK INTERACTIVE LLC, ST. PAUL, MN. FILED 4-14-2011.

On the Green! Golf

THE MARK CONSISTS OF STANDARD CHARACTERS WITHOUT CLAIM TO ANY PARTICULAR FONT, STYLE, SIZE, OR COLOR.

NO CLAIM IS MADE TO THE EXCLUSIVE RIGHT TO USE "GOLF", APART FROM THE MARK AS SHOWN.

FOR COMPUTER GAME PROGRAMMES DOWNLOADABLE VIA THE INTERNET; COMPUTER GAME SOFTWARE DOWNLOADABLE FROM A GLOBAL COMPUTER NETWORK; COMPUTER GAME SOFTWARE FOR USE ON MOBILE AND CELLULAR PHONES; DOWNLOADABLE COMPUTER GAME PROGRAMS; DOWNLOADABLE COMPUTER GAME SOFTWARE VIA A GLOBAL COMPUTER NETWORK AND WIRELESS DEVICES; GAME SOFTWARE (U.S. CLS. 21, 23, 26, 36 AND 38).

JOHN GARTNER, EXAMINING ATTORNEY

SN 85-295,806. GEOCOVE INC, ORLANDO, FL. FILED 4-14-2011.

ARM360

SN 85-295,599. ILLUSION LABS AB, 21135 MALMÖ, SWEDEN, FILED 4-14-2011.

TOUCHGRIND

THE MARK CONSISTS OF STANDARD CHARACTERS WITHOUT CLAIM TO ANY PARTICULAR FONT, STYLE, SIZE, OR COLOR.

FOR DOWNLOADABLE COMPUTER GAME PROGRAMS (U.S. CLS. 21, 23, 26, 36 AND 38).

FIRST USE 11-0-2008; IN COMMERCE 11-0-2008.

HELENE LIWINSKI, EXAMINING ATTORNEY

THE MARK CONSISTS OF STANDARD CHARACTERS WITHOUT CLAIM TO ANY PARTICULAR FONT, STYLE, SIZE, OR COLOR.

FOR COMPUTER SOFTWARE FOR NAMELY, STORING, RETRIEVING, AND DISPLAYING DATA IN A GEOGRAPHIC FORMAT, FOR THE MANAGEMENT OF GEOGRAPHIC AND SPATIAL DATA (U.S. CLS. 21, 23, 26, 36 AND 38).

FIRST USE 11-20-2010; IN COMMERCE 4-1-2011.

WILLIAM VERHOSEK, EXAMINING ATTORNEY

CLASS 9—(Continued).

SN 85-296,229. UNITED STATES POLO ASSOCIATION, LEXINGTON, KY. FILED 4-15-2011.



OWNER OF U.S. REG. NOS. 2,188,594 AND 3,598,829.
THE MARK CONSISTS OF AN ILLUSTRATION OF TWO POLO PLAYERS PURSUING A POLO BALL, CHARGING DIRECTLY TOWARD THE VIEWER.

FOR EYEWEAR, NAMELY, OPHTHALMIC EYEWEAR FRAMES, READING GLASSES, SUNGLASSES, EYEGlass CASES AND COVERS, SUN CLIPS IN THE NATURE OF EYEWEAR (U.S. CLS. 21, 23, 26, 36 AND 38).

SCOTT BIBB, EXAMINING ATTORNEY

SN 85-296,257. BRYAN FAMILY ENTERPRISES LLC, UNION CITY, CA. FILED 4-15-2011.

Taming the Blazing Sun

THE MARK CONSISTS OF STANDARD CHARACTERS WITHOUT CLAIM TO ANY PARTICULAR FONT, STYLE, SIZE, OR COLOR.

FOR SPORTS HELMETS ACCESSORIES, NAMELY, DETACHABLE BRIMS, SUNSHADES, AND VISORS FOR USE WITH SPORTS HELMETS (U.S. CLS. 21, 23, 26, 36 AND 38).

MARC LEIPZIG, EXAMINING ATTORNEY

CLASS 9—(Continued).

SN 85-296,273. HOME BOX OFFICE, INC., NEW YORK, NY. FILED 4-15-2011.



OWNER OF U.S. REG. NOS. 1,349,993, 3,904,923 AND OTHERS.

THE MARK CONSISTS OF "CINEMAX" IN SLANTED BLOCK LETTERS ON A QUADRILATERAL BACKGROUND.

FOR PRE-RECORDED VIDEO DISCS, DVDS, HIGH DEFINITION DIGITAL DISCS, AND VIDEOTAPES FEATURING DRAMA, COMEDY, ACTION, ADVENTURE, DOCUMENTARY, SPORTS, MUSIC AND VARIETY; COMPACT DISCS AND DIGITAL AUDIO DISCS FEATURING CONTENT FROM OR RELATED TO TELEVISION PROGRAMMING OR TELEVISION SERIES; MOTION PICTURE FILMS AND FILMS FOR TELEVISION FEATURING DRAMA, COMEDY, ACTION, ADVENTURE, DOCUMENTARY, SPORTS, MUSIC AND VARIETY; PRE-RECORDED DIGITAL MEDIA FEATURING DRAMA, COMEDY, ACTION, ADVENTURE, DOCUMENTARY, SPORTS, MUSIC, VARIETY, ENTERTAINMENT NEWS, DOCUMENTARY AND ANIMATION; MUSICAL SOUND RECORDINGS; MUSICAL VIDEO RECORDINGS (U.S. CLS. 21, 23, 26, 36 AND 38).

SUSAN RICHARDS, EXAMINING ATTORNEY

SN 85-296,575. AUTHENTEC, INC., MELBOURNE, FL. FILED 4-15-2011.

FIDO

THE MARK CONSISTS OF STANDARD CHARACTERS WITHOUT CLAIM TO ANY PARTICULAR FONT, STYLE, SIZE, OR COLOR.

FOR CONTACTLESS CARD AND ELECTRONIC WALLET SYSTEMS COMPRISING A BIOMETRIC SENSOR, SECURE PROCESSOR, NEAR FIELD COMMUNICATION RADIO FREQUENCY UNIT, PROXIMITY DETECTOR, AND POWER SUPPLY WHICH IS READ BY A CONTACTLESS READING MACHINE FOR USE AS CREDIT CARDS, DEBIT CARDS, IDENTIFICATION OR AUTHENTICATION CARDS, AND CARDLESS ELECTRONIC PAYMENTS; COMPUTER SOFTWARE, NAMELY, SOFTWARE TO AUTOMATE SERVICE ACCOUNT PASSWORD MANAGEMENT AND RETRIEVAL BY ENABLING AUTHENTICATION OF PERSONAL IDENTITY USING BIOMETRIC INFORMATION; NEAR FIELD COMMUNICATION (NFC) TECHNOLOGY-ENABLED READERS AND DEVICES, NAMELY, POINT OF SALE DEVICES, MOBILE PHONES, AND PERSONAL DIGITAL ASSISTANTS (PDAS) (U.S. CLS. 21, 23, 26, 36 AND 38).

ANDREA HACK, EXAMINING ATTORNEY

CLASS 9—(Continued).

SN 85-296,688. SILICONIX INCORPORATED, SANTA CLARA, CA. FILED 4-15-2011.

SILICONIX

THE MARK CONSISTS OF STANDARD CHARACTERS WITHOUT CLAIM TO ANY PARTICULAR FONT, STYLE, SIZE, OR COLOR.

FOR SEMICONDUCTOR DEVICES (U.S. CLS. 21, 23, 26, 36 AND 38).

FIRST USE 12-31-1962; IN COMMERCE 12-31-1962.
ADA HAN, EXAMINING ATTORNEY

SN 85-296,841. PERRY ANDROPOLIS, STURGEON BAY, WI. FILED 4-15-2011.

Breeze-thru

THE MARK CONSISTS OF STANDARD CHARACTERS WITHOUT CLAIM TO ANY PARTICULAR FONT, STYLE, SIZE, OR COLOR.

FOR TRAFFIC MANAGEMENT EQUIPMENT, NAMELY, DISPLAY MONITORS, COMPUTERS, AUTO COMPASSES, AND SOFTWARE TO MANAGE TRAFFIC (U.S. CLS. 21, 23, 26, 36 AND 38).

ERNEST SHOSHO, EXAMINING ATTORNEY

SN 85-296,914. JOREL NICK, ANNAPOLIS, MD. FILED 4-15-2011.

Big Freeze

THE MARK CONSISTS OF STANDARD CHARACTERS WITHOUT CLAIM TO ANY PARTICULAR FONT, STYLE, SIZE, OR COLOR.

FOR MUSICAL SOUND RECORDINGS; SOUND RECORDINGS FEATURING MUSIC (U.S. CLS. 21, 23, 26, 36 AND 38).

PATRICIA EVANKO, EXAMINING ATTORNEY

CLASS 9—(Continued).

SN 85-298,070. IGT, RENO, NV. FILED 4-18-2011.

MYSTICAL PARADISE

THE MARK CONSISTS OF STANDARD CHARACTERS WITHOUT CLAIM TO ANY PARTICULAR FONT, STYLE, SIZE, OR COLOR.

OWNER OF U.S. REG. NOS. 2,903,842, 3,459,085 AND 3,920,332.

FOR GAMING MACHINES, NAMELY, DEVICES WHICH ACCEPT A WAGER (U.S. CLS. 21, 23, 26, 36 AND 38).

CARYN GLASSER, EXAMINING ATTORNEY

SN 85-298,389. JUICY COUTURE, INC., PACOIMA, CA. FILED 4-19-2011.

JUICY COUTURE

THE MARK CONSISTS OF STANDARD CHARACTERS WITHOUT CLAIM TO ANY PARTICULAR FONT, STYLE, SIZE, OR COLOR.

OWNER OF U.S. REG. NOS. 2,348,674, 3,941,099 AND OTHERS.

NO CLAIM IS MADE TO THE EXCLUSIVE RIGHT TO USE "COUTURE", APART FROM THE MARK AS SHOWN.

FOR CARRYING CASES FOR ELECTRONIC EQUIPMENT, NAMELY, CELL PHONES, LAPTOPS, PORTABLE READERS, EAR BUDS AND PORTABLE MEDIA PLAYERS; EAR BUDS; PROTECTIVE COVERS AND CASES FOR CELL PHONES, LAPTOPS AND PORTABLE MEDIA PLAYERS; PROTECTIVE COVERS FOR ELECTRONIC READING DEVICES; USB (UNIVERSAL SERIAL BUS) HARDWARE; WIRELESS COMPUTER MICE (U.S. CLS. 21, 23, 26, 36 AND 38).

CHARISMA HAMPTON, EXAMINING ATTORNEY

SN 85-298,736. WARNER BROS. ENTERTAINMENT INC., BURBANK, CA. FILED 4-19-2011.

FRIENDS THE ONE WITH ALL THE TRIVIA

THE MARK CONSISTS OF STANDARD CHARACTERS WITHOUT CLAIM TO ANY PARTICULAR FONT, STYLE, SIZE, OR COLOR.

OWNER OF U.S. REG. NO. 2,032,383.

FOR CD ROM COMPUTER GAME DISCS; GAME EQUIPMENT SOLD AS A UNIT FOR PLAYING A PARLOR-TYPE COMPUTER GAME, NAMELY, VIDEO OUTPUT GAME MACHINES FOR USE WITH TELEVISIONS AND COMPUTER GAME SOFTWARE; VIDEO AND COMPUTER GAME PROGRAMS; VIDEO GAME CARTRIDGES AND CASSETTES (U.S. CLS. 21, 23, 26, 36 AND 38).

FIRST USE 11-15-2005; IN COMMERCE 11-15-2005.

MARY BOAGNI, EXAMINING ATTORNEY

CLASS 9—(Continued).

SN 85-298,750. KELLWOOD COMPANY, CHESTERFIELD, MO. FILED 4-19-2011.

BLK DNM

THE MARK CONSISTS OF THE LETTERS "BLK DNM" IN A STYLIZED FONT.

FOR CASES FOR EYEGLASSES AND SUNGLASSES; EYEWEAR; FRAMES FOR SPECTACLES AND SUNGLASSES; LENSES FOR SUNGLASSES; SUNGLASS CHAINS AND CORDS; SUNGLASSES AND SPECTACLES (U.S. CLS. 21, 23, 26, 36 AND 38).

EUGENIA MARTIN, EXAMINING ATTORNEY

SN 85-301,060. TYCO ELECTRONICS CORPORATION, BERYN, PA. FILED 4-21-2011.

FORTIS ZD

THE MARK CONSISTS OF STANDARD CHARACTERS WITHOUT CLAIM TO ANY PARTICULAR FONT, STYLE, SIZE, OR COLOR.

FOR ELECTRICAL CONNECTORS (U.S. CLS. 21, 23, 26, 36 AND 38).

INGRID C. EULIN, EXAMINING ATTORNEY

SN 85-303,753. CORNING INCORPORATED, CORNING, NY. FILED 4-25-2011.

CORNING ELEMENT

THE MARK CONSISTS OF STANDARD CHARACTERS WITHOUT CLAIM TO ANY PARTICULAR FONT, STYLE, SIZE, OR COLOR.

OWNER OF U.S. REG. NOS. 618,649, 1,748,228 AND OTHERS.

SEC. 2(F) AS TO "CORNING".

FOR LABORATORY WARE, NAMELY, CENTRIFUGE TUBES AND PIPETTES (U.S. CLS. 21, 23, 26, 36 AND 38).

MICHAEL TANNER, EXAMINING ATTORNEY

CLASS 9—(Continued).

SN 85-303,914. IGT, RENO, NV. FILED 4-25-2011.

MISS RED

THE MARK CONSISTS OF STANDARD CHARACTERS WITHOUT CLAIM TO ANY PARTICULAR FONT, STYLE, SIZE, OR COLOR.

FOR GAMING MACHINES, NAMELY, DEVICES WHICH ACCEPT A WAGER (U.S. CLS. 21, 23, 26, 36 AND 38).

CARYN GLASSER, EXAMINING ATTORNEY

SN 85-304,389. SAGAR, VINOD, CORONA, CA. FILED 4-26-2011.

ZEEPAD

THE MARK CONSISTS OF STANDARD CHARACTERS WITHOUT CLAIM TO ANY PARTICULAR FONT, STYLE, SIZE, OR COLOR.

FOR COMPUTER TABLET PC (U.S. CLS. 21, 23, 26, 36 AND 38).

ARETHA SOMERVILLE, EXAMINING ATTORNEY

SN 85-305,591. REYNOLDS, ALLISON, COONABARABRAN, AUSTRALIA, FILED 4-27-2011.



NO CLAIM IS MADE TO THE EXCLUSIVE RIGHT TO USE "SLOW CARB APP", APART FROM THE MARK AS SHOWN.

THE COLOR(S) ORANGE AND BLUE IS/ARE CLAIMED AS A FEATURE OF THE MARK.

THE MARK CONSISTS OF THE WORDING "SLOWCARB APP" IN BLUE WITH THE WORD "APP" APPEARING AS A

CLASS 9—(Continued).

SUPERSCRIPIT. THE WORDING "SLOWCARB APP" APPEARS BELOW A SQUARE WITH ROUNDED CORNERS, APPEARING IN SHADES OF LIGHTER TO DARKER ORANGE, OUTLINED IN DARKER ORANGE, AND CONTAINING A BLUE DESIGN WITH SPIKES THAT LOOK LIKE TWO FISHES FACING EACH OTHER AND WITH A BLUE CIRCLE ABOVE THE FISHES. THE SQUARE WITH ROUNDED CORNERS CASTS A LIGHT ORANGE SHADOW UPON THE WORDS "SLOWCARB" AS SHOWN IN THE MARK.

FOR COMPUTER APPLICATION SOFTWARE FOR MOBILE PHONES, COMPUTERS, HANDHELD COMPUTERS, NAMELY, SOFTWARE FOR RECORDING PROGRESS AND KEEPING TRACK OF EATING FOR VARIOUS DIET TYPES AND EXERCISING (U.S. CLS. 21, 23, 26, 36 AND 38).

AMY KERTGATE, EXAMINING ATTORNEY

SN 85-305,667. NEWSOFT TECHNOLOGY CORPORATION, TAIPEI CITY, TAIWAN, FILED 4-27-2011.

FotoTap

THE MARK CONSISTS OF STANDARD CHARACTERS WITHOUT CLAIM TO ANY PARTICULAR FONT, STYLE, SIZE, OR COLOR.

FOR COMPUTER SOFTWARE RELATING TO THE CREATION, GENERATING, RECEIVING, RETRIEVING, CAPTURING, CARRYING, DISPLAYING, PLAYING, RECORDING, PROCESSING, ORGANIZING, AUTHORIZING, REPRODUCING, EDITING, TRANSMITTING, DISTRIBUTING, ENCODING AND DECODING OF DIGITAL INFORMATION, NAMELY, AUDIO, VIDEO, PHOTOS, GRAPHICS, STILL IMAGES, MOVING PICTURES, TEXT DATA, AND USER MANUALS SOLD AS A UNIT THEREWITH (U.S. CLS. 21, 23, 26, 36 AND 38).

TINA MAI, EXAMINING ATTORNEY

CLASS 9—(Continued).

SN 85-305,818. Z SPOKE, LLC, NEW YORK, NY. FILED 4-27-2011.



OWNER OF U.S. REG. NOS. 3,514,935 AND 3,514,942.

THE MARK CONSISTS OF THE LETTER "Z" SURROUNDED BY A CIRCLE, WITH A HORIZONTAL LINE SUPERIMPOSED OVER THE LETTER "Z" WITH THE LETTER "Z" THEN SUPERIMPOSED OVER SEVERAL RADIATING SPOKES.

FOR EYEWEAR, NAMELY, EYEGLASSES, SUNGLASSES AND EYEGLASS AND SUNGLASS CASES (U.S. CLS. 21, 23, 26, 36 AND 38).

JUDITH HELFMAN, EXAMINING ATTORNEY

SN 85-307,318. ALBERT METZ GMBH & CO. KG, BLUMBERG, FED REP GERMANY, FILED 4-28-2011.



THE COLOR(S) BLACK AND BLUE IS/ARE CLAIMED AS A FEATURE OF THE MARK.

THE MARK CONSISTS OF THE LETTERS "MCQTECH" IN BLACK STYLIZED LETTERING WITH THE LETTER "M" INSIDE A BLUE QUADRILATERAL.

FOR ELECTRICAL TERMINAL BLOCKS, ELECTRICAL HEADERS AND ELECTRICAL PLUGS FOR USE WITH CONNECTION OF PRINTED CIRCUIT BOARDS; ELECTRICAL CONNECTOR PLUGS, ELECTRICAL CONNECTOR SOCKETS, ELECTRICAL CONNECTOR TERMINALS, ELECTRICAL ADAPTERS, ELECTRICAL CONNECTION BOXES, PATCH PANELS FOR DATA AND TELECOMMUNICATION NETWORKS, ELECTRIC RELAYS, ELECTRIC SWITCHES, ELECTRICAL CABLES AND CIRCUIT TESTERS FOR USE DURING INSTALLATION, ALL AFOREMENTIONED GOODS FOR ELECTRICAL NETWORKS AND FIBER OPTIC NETWORKS FOR DATA TRANSMISSION AND TELECOMMUNICATION (U.S. CLS. 21, 23, 26, 36 AND 38).

LESLIE RICHARDS, EXAMINING ATTORNEY

CLASS 9—(Continued).

SN 85-308,337. T-MOBILE USA, INC., BELLEVUE, WA. FILED 4-29-2011.

BURSTSHOT

THE MARK CONSISTS OF STANDARD CHARACTERS WITHOUT CLAIM TO ANY PARTICULAR FONT, STYLE, SIZE, OR COLOR.

FOR WIRELESS HANDHELD TELECOMMUNICATIONS DEVICES THAT COMBINE WIRELESS VOICE AND DATA TELECOMMUNICATIONS FUNCTIONS, DIGITAL IMAGING FUNCTIONS FOR CAPTURING, CREATING, VIEWING, MANIPULATING AND EDITING DIGITAL PHOTOGRAPHS AND IMAGES, COMPUTING FUNCTIONS, PERMIT THE TWO-WAY WIRELESS TRANSMISSION OF E-MAIL AND TEXT, PERMIT WIRELESS ACCESS TO A GLOBAL COMPUTER NETWORK, GAMING AND MULTIMEDIA FUNCTIONALITY; WIRELESS HANDHELD TELECOMMUNICATIONS DEVICE SOFTWARE THAT ENABLES THE CAPTURING, CREATING, VIEWING, MANIPULATING AND EDITING DIGITAL PHOTOGRAPHS AND IMAGES (U.S. CLS. 21, 23, 26, 36 AND 38).
TRACY FLETCHER, EXAMINING ATTORNEY

SN 85-308,885. ARCSOFT, INC., FREMONT, CA. FILED 4-29-2011.

FAMILY PAINT

THE MARK CONSISTS OF STANDARD CHARACTERS WITHOUT CLAIM TO ANY PARTICULAR FONT, STYLE, SIZE, OR COLOR.

FOR COMPUTER SOFTWARE FOR CREATING, AUTHORING, VIEWING, ORGANIZING, EDITING AND SHARING DIGITAL PHOTOGRAPHS AND IMAGES, AUDIOS, VIDEOS, 3D IMAGES AND OBJECTS, AND MULTIMEDIA WORKS (U.S. CLS. 21, 23, 26, 36 AND 38).
SUZANNE BLANE, EXAMINING ATTORNEY

SN 85-309,116. PAULSSON, INC., WOODLAND HILLS, CA. FILED 4-30-2011.

OpticSeis

THE MARK CONSISTS OF STANDARD CHARACTERS WITHOUT CLAIM TO ANY PARTICULAR FONT, STYLE, SIZE, OR COLOR.

FOR SEISMIC EXPLORATION MACHINES AND APPARATUS (U.S. CLS. 21, 23, 26, 36 AND 38).
JACLYN KIDWELL WALKER, EXAMINING ATTORNEY

CLASS 9—(Continued).

SN 85-309,850. GLOBAL EVANGELISM, INC., SAN ANTONIO, TX. FILED 5-2-2011.

DIFFERENCE MEDIA

THE MARK CONSISTS OF STANDARD CHARACTERS WITHOUT CLAIM TO ANY PARTICULAR FONT, STYLE, SIZE, OR COLOR.

NO CLAIM IS MADE TO THE EXCLUSIVE RIGHT TO USE "MEDIA", APART FROM THE MARK AS SHOWN.
FOR AUDIO AND VIDEO RECORDINGS FEATURING MUSIC (U.S. CLS. 21, 23, 26, 36 AND 38).
FIRST USE 4-17-2011; IN COMMERCE 4-17-2011.
EVELYN BRADLEY, EXAMINING ATTORNEY

SN 85-310,112. GENERAL ELECTRIC COMPANY, SCHENECTADY, NY. FILED 5-2-2011.

ElectroBlox

THE MARK CONSISTS OF STANDARD CHARACTERS WITHOUT CLAIM TO ANY PARTICULAR FONT, STYLE, SIZE, OR COLOR.

FOR ELECTRONIC SIGNALING MECHANISM, NAMELY, A TRAIN CONTROL SYSTEM USED IN THE RAILWAY INDUSTRY FOR DETECTING AND CONTROLLING TRAINS, GROUND FAULTS, BROKEN RAILS, POWER FAILURES, TRACK SWITCHES AND LIGHTS; PROGRAMMABLE LOGIC CONTROLLER (PLC) (U.S. CLS. 21, 23, 26, 36 AND 38).
MICHAEL SOUDERS, EXAMINING ATTORNEY

SN 85-310,231. VILLAIN LLC, CARY, NC. FILED 5-2-2011.

POCKET BIRDS

THE MARK CONSISTS OF STANDARD CHARACTERS WITHOUT CLAIM TO ANY PARTICULAR FONT, STYLE, SIZE, OR COLOR.

FOR COMPUTER SOFTWARE FOR MOBILE PHONES, MOBILE DEVICES, AND HANDHELD ELECTRONIC DEVICES, NAMELY, VIDEO GAME VIRTUAL PET RAISING AND COLLECTING SOFTWARE; DOWNLOADABLE COMPUTER GAME PROGRAMS; DOWNLOADABLE COMPUTER GAME SOFTWARE VIA A GLOBAL COMPUTER NETWORK AND WIRELESS DEVICES; ELECTRONIC GAME SOFTWARE FOR CELLULAR TELEPHONES; ELECTRONIC GAME SOFTWARE FOR HANDHELD ELECTRONIC DEVICES; ELECTRONIC GAME SOFTWARE FOR WIRELESS DEVICES (U.S. CLS. 21, 23, 26, 36 AND 38).
JESSICA A. POWERS, EXAMINING ATTORNEY

CLASS 9—(Continued).

SN 85-311,013. VILLAIN LLC, CARY, NC. FILED 5-3-2011.

MICRO

THE MARK CONSISTS OF STANDARD CHARACTERS WITHOUT CLAIM TO ANY PARTICULAR FONT, STYLE, SIZE, OR COLOR.

FOR COMPUTER APPLICATION SOFTWARE FOR MOBILE PHONES, HANDHELD ELECTRONIC DEVICES, NAMELY, SOFTWARE FOR UPLOADING, POSTING, SHOWING, DISPLAYING, TAGGING, BLOGGING, SHARING OR OTHERWISE PROVIDING ELECTRONIC MEDIA OR INFORMATION IN THE FIELDS OF VIRTUAL COMMUNITIES, ELECTRONIC GAMING, ENTERTAINMENT, AND GENERAL INTEREST VIA THE INTERNET OR OTHER COMMUNICATIONS NETWORKS WITH THIRD PARTIES; COMPUTER GAME SOFTWARE; COMPUTER GAME SOFTWARE DOWNLOADABLE FROM A GLOBAL COMPUTER NETWORK; COMPUTER GAME SOFTWARE FOR USE ON MOBILE AND CELLULAR PHONES; COMPUTER SOFTWARE FOR SOCIAL NETWORKING; DOWNLOADABLE COMPUTER SOFTWARE FOR SOCIAL NETWORKING THAT MAY BE ACCESSED VIA THE INTERNET, COMPUTERS AND WIRELESS DEVICES; ELECTRONIC GAME PROGRAMS; ELECTRONIC GAME SOFTWARE; ELECTRONIC GAME SOFTWARE FOR CELLULAR TELEPHONES; ELECTRONIC GAME SOFTWARE FOR HANDHELD ELECTRONIC DEVICES; ELECTRONIC GAME SOFTWARE FOR WIRELESS DEVICES; INTERACTIVE VIDEO GAME PROGRAMS; VIDEO GAME SOFTWARE (U.S. CLS. 21, 23, 26, 36 AND 38).

JESSICA A. POWERS, EXAMINING ATTORNEY

SN 85-311,164. BALLY GAMING, INC., DBA BALLY TECHNOLOGIES, LAS VEGAS, NV. FILED 5-3-2011.

BURIED TREASURES

THE MARK CONSISTS OF STANDARD CHARACTERS WITHOUT CLAIM TO ANY PARTICULAR FONT, STYLE, SIZE, OR COLOR.

FOR GAMING MACHINES, NAMELY, DEVICES WHICH ACCEPT A WAGER AND GAMING SOFTWARE THAT GENERATES OR DISPLAYS OUTCOMES FOR GAMING MACHINES (U.S. CLS. 21, 23, 26, 36 AND 38).

WENDY GOODMAN, EXAMINING ATTORNEY

CLASS 9—(Continued).

SN 85-311,298. BALLY GAMING, INC., DBA BALLY TECHNOLOGIES, LAS VEGAS, NV. FILED 5-3-2011.

SUPER FIREBALL FRENZY

THE MARK CONSISTS OF STANDARD CHARACTERS WITHOUT CLAIM TO ANY PARTICULAR FONT, STYLE, SIZE, OR COLOR.

OWNER OF U.S. REG. NOS. 3,090,347 AND 3,849,633.
FOR GAMING MACHINES, NAMELY, DEVICES WHICH ACCEPT A WAGER AND GAMING SOFTWARE THAT GENERATES OR DISPLAYS OUTCOMES FOR GAMING MACHINES (U.S. CLS. 21, 23, 26, 36 AND 38).
FIRST USE 8-12-2008; IN COMMERCE 8-12-2008.
WENDY GOODMAN, EXAMINING ATTORNEY

SN 85-311,498. BALLY GAMING, INC., DBA BALLY TECHNOLOGIES, LAS VEGAS, NV. FILED 5-3-2011.

DOUBLE DRAGON

THE MARK CONSISTS OF STANDARD CHARACTERS WITHOUT CLAIM TO ANY PARTICULAR FONT, STYLE, SIZE, OR COLOR.

FOR GAMING MACHINES, NAMELY, DEVICES WHICH ACCEPT A WAGER AND GAMING SOFTWARE THAT GENERATES OR DISPLAYS OUTCOMES FOR GAMING MACHINES (U.S. CLS. 21, 23, 26, 36 AND 38).
FIRST USE 3-14-2007; IN COMMERCE 3-14-2007.
WENDY GOODMAN, EXAMINING ATTORNEY

SN 85-311,909. CALLAWAY GOLF COMPANY, CARLSBAD, CA. FILED 5-4-2011.

XTT XTREME

THE MARK CONSISTS OF STANDARD CHARACTERS WITHOUT CLAIM TO ANY PARTICULAR FONT, STYLE, SIZE, OR COLOR.

FOR EYEWEAR (U.S. CLS. 21, 23, 26, 36 AND 38).
FIRST USE 6-28-2010; IN COMMERCE 6-28-2010.
BARBARA A. GOLD, EXAMINING ATTORNEY

CLASS 9—(Continued).

SN 85-311,925. BOSCOV'S INVESTMENT COMPANY, INC., WILMINGTON, DE. FILED 5-4-2011.

ARCHITECT

THE MARK CONSISTS OF STANDARD CHARACTERS WITHOUT CLAIM TO ANY PARTICULAR FONT, STYLE, SIZE, OR COLOR.

OWNER OF U.S. REG. NO. 1,417,523.
FOR EYEWEAR, NAMELY, EYEGLASSES AND SUN-GLASSES (U.S. CLS. 21, 23, 26, 36 AND 38).
FIRST USE 7-0-2008; IN COMMERCE 7-0-2008.
THEODORE MCBRIDE, EXAMINING ATTORNEY

SN 85-312,158. BALLY GAMING, INC., DBA BALLY TECHNOLOGIES, LAS VEGAS, NV. FILED 5-4-2011.

HOT LINES

THE MARK CONSISTS OF STANDARD CHARACTERS WITHOUT CLAIM TO ANY PARTICULAR FONT, STYLE, SIZE, OR COLOR.

NO CLAIM IS MADE TO THE EXCLUSIVE RIGHT TO USE "LINES", APART FROM THE MARK AS SHOWN.

FOR GAMING MACHINES, NAMELY, DEVICES WHICH ACCEPT A WAGER AND GAMING SOFTWARE THAT GENERATES OR DISPLAYS OUTCOMES FOR GAMING MACHINES (U.S. CLS. 21, 23, 26, 36 AND 38).
FIRST USE 1-10-2007; IN COMMERCE 1-10-2007.
WENDY GOODMAN, EXAMINING ATTORNEY

SN 85-312,409. BALLY GAMING, INC., DBA BALLY TECHNOLOGIES, LAS VEGAS, NV. FILED 5-4-2011.

MONEY MATCH

THE MARK CONSISTS OF STANDARD CHARACTERS WITHOUT CLAIM TO ANY PARTICULAR FONT, STYLE, SIZE, OR COLOR.

NO CLAIM IS MADE TO THE EXCLUSIVE RIGHT TO USE "MONEY", APART FROM THE MARK AS SHOWN.

FOR GAMING MACHINES, NAMELY, DEVICES WHICH ACCEPT A WAGER AND GAMING SOFTWARE THAT GENERATES OR DISPLAYS OUTCOMES FOR GAMING MACHINES (U.S. CLS. 21, 23, 26, 36 AND 38).
FIRST USE 4-15-2003; IN COMMERCE 4-15-2003.
WENDY GOODMAN, EXAMINING ATTORNEY

CLASS 9—(Continued).

SN 85-312,453. BALLY GAMING, INC., DBA BALLY TECHNOLOGIES, LAS VEGAS, NV. FILED 5-4-2011.

CASH METEOR

THE MARK CONSISTS OF STANDARD CHARACTERS WITHOUT CLAIM TO ANY PARTICULAR FONT, STYLE, SIZE, OR COLOR.

NO CLAIM IS MADE TO THE EXCLUSIVE RIGHT TO USE "CASH", APART FROM THE MARK AS SHOWN.

FOR GAMING MACHINES, NAMELY, DEVICES WHICH ACCEPT A WAGER AND GAMING SOFTWARE THAT GENERATES OR DISPLAYS OUTCOMES FOR GAMING MACHINES (U.S. CLS. 21, 23, 26, 36 AND 38).
FIRST USE 10-14-2009; IN COMMERCE 10-14-2009.
WENDY GOODMAN, EXAMINING ATTORNEY

SN 85-312,727. BALLY GAMING, INC., DBA BALLY TECHNOLOGIES, LAS VEGAS, NV. FILED 5-4-2011.

MONEY VAULT

THE MARK CONSISTS OF STANDARD CHARACTERS WITHOUT CLAIM TO ANY PARTICULAR FONT, STYLE, SIZE, OR COLOR.

NO CLAIM IS MADE TO THE EXCLUSIVE RIGHT TO USE "MONEY", APART FROM THE MARK AS SHOWN.

FOR GAMING MACHINES, NAMELY, DEVICES WHICH ACCEPT A WAGER AND GAMING SOFTWARE THAT GENERATES OR DISPLAYS OUTCOMES FOR GAMING MACHINES (U.S. CLS. 21, 23, 26, 36 AND 38).
FIRST USE 2-1-2011; IN COMMERCE 2-1-2011.
WENDY GOODMAN, EXAMINING ATTORNEY

CLASS 9—(Continued).

SN 85-312,792. ZWCAD SOFTWARE CO., LTD., GUANGZHOU, GUANGDONG, CHINA, FILED 5-4-2011.

ZWSOFT

OWNER OF U.S. REG. NO. 3,612,724.
NO CLAIM IS MADE TO THE EXCLUSIVE RIGHT TO USE "SOFT", APART FROM THE MARK AS SHOWN.

THE MARK CONSISTS OF THE WORDING "ZW" AND "SOFT", WITH A TRIANGLE DESIGN ON THE UPPER RIGHT ARM OF THE "W".

FOR COMMUNICATION SOFTWARE TO ACCESS DATA STORED ON AN OXIMETER AND TRANSFER DATA TO ANOTHER DEVICE; COMPUTER APPLICATION SOFTWARE FOR MOBILE PHONES, NAMELY, SOFTWARE FOR USE IN DATABASE MANAGEMENT AND USE IN ELECTRONIC STORAGE OF DATA; COMPUTER APPLICATION SOFTWARE FOR HANDHELD COMPUTER, NAMELY, SOFTWARE FOR THE INTEGRATION OF TEXT, AUDIO, GRAPHICS, STILL IMAGES AND MOVING PICTURES INTO AN INTERACTIVE DELIVERY FOR MULTIMEDIA APPLICATIONS; COMPUTER GAME PROGRAMMES; COMPUTER OPERATING PROGRAMS; COMPUTER PROGRAMS AND COMPUTER SOFTWARE FOR ELECTRONICALLY TRADING SECURITIES; COMPUTER PROGRAMS RECORDED ON DATA MEDIA (SOFTWARE) DESIGNED FOR USE IN CONSTRUCTION AND AUTOMATED MANUFACTURING (CAD/CAM); COMPUTER SOFTWARE FOR APPLICATION AND DATABASE INTEGRATION; ELECTRONIC PUBLICATIONS, NAMELY, BOOKS, MAGAZINES, MANUALS FEATURING SCIENCE AND MEDICINE RECORDED ON COMPUTER MEDIA (U.S. CLS. 21, 23, 26, 36 AND 38).

FIRST USE 8-24-1998; IN COMMERCE 2-8-2004.
DAVID HOFFMAN, EXAMINING ATTORNEY

CLASS 9—(Continued).

SN 85-314,186. TIMELINES, INC., CHICAGO, IL. FILED 5-6-2011.



THE COLOR(S) RED AND WHITE IS/ARE CLAIMED AS A FEATURE OF THE MARK.

THE MARK CONSISTS OF A POSTAGE STAMP DESIGN WITH THE STAMP APPEARING IN RED, WITH A WHITE HEART IN THE CENTER OF THE STAMP.

FOR COMPUTER SOFTWARE FOR USE IN CAPTURING, ORGANIZING, SEARCHING, INDEXING, STORING, SYNCHRONIZING, RECOGNIZING, SHARING, TRANSMITTING AND DISPLAYING DIGITAL FILES, INCLUDING AUDIO, VIDEO, TEXT, BINARY, STILL IMAGES, GRAPHICS, DIGITAL CONTENT AND MULTIMEDIA FILES; DOWNLOADABLE COMPUTER SOFTWARE FOR USE IN CAPTURING, ORGANIZING, SEARCHING, INDEXING, STORING, SYNCHRONIZING, RECOGNIZING, SHARING AND TRANSMITTING DIGITAL FILES, INCLUDING AUDIO, VIDEO, TEXT, BINARY, STILL IMAGES, GRAPHICS, DIGITAL CONTENT, AND MULTIMEDIA FILES (U.S. CLS. 21, 23, 26, 36 AND 38).

FIRST USE 3-10-2011; IN COMMERCE 3-10-2011.
HEATHER BIDDULPH, EXAMINING ATTORNEY

SN 85-314,268. BLUBERI JEUX ET TECHNOLOGIES INC. AKA BLUBERI GAMING TECHNOLOGIES INC., DRUMMONDVILLE, QUEBEC, CANADA, FILED 5-6-2011.

SEVENS ON THE ROCKS

THE MARK CONSISTS OF STANDARD CHARACTERS WITHOUT CLAIM TO ANY PARTICULAR FONT, STYLE, SIZE, OR COLOR.

FOR SOFTWARE FOR GAMING MACHINES; GAMING MACHINES WITH VIDEO OUTPUT (U.S. CLS. 21, 23, 26, 36 AND 38).

WILLIAM P. SHANAHAN, EXAMINING ATTORNEY

CLASS 9—(Continued).

SN 85-314,748. BALLY GAMING, INC., DBA BALLY TECHNOLOGIES, LAS VEGAS, NV. FILED 5-6-2011.

TWO WAY FRENZY

THE MARK CONSISTS OF STANDARD CHARACTERS WITHOUT CLAIM TO ANY PARTICULAR FONT, STYLE, SIZE, OR COLOR.

OWNER OF U.S. REG. NOS. 3,090,347 AND 3,849,633.
FOR GAMING MACHINES, NAMELY, DEVICES WHICH ACCEPT A WAGER AND GAMING SOFTWARE THAT GENERATES OR DISPLAYS OUTCOMES FOR GAMING MACHINES (U.S. CLS. 21, 23, 26, 36 AND 38).

FIRST USE 8-15-2007; IN COMMERCE 8-15-2007.
WENDY GOODMAN, EXAMINING ATTORNEY

SN 85-314,878. BALLY GAMING, INC., DBA BALLY TECHNOLOGIES, LAS VEGAS, NV. FILED 5-6-2011.

BLACK GOLD BLACK

THE MARK CONSISTS OF STANDARD CHARACTERS WITHOUT CLAIM TO ANY PARTICULAR FONT, STYLE, SIZE, OR COLOR.

FOR GAMING MACHINES, NAMELY, DEVICES WHICH ACCEPT A WAGER AND GAMING SOFTWARE THAT GENERATES OR DISPLAYS OUTCOMES FOR GAMING MACHINES (U.S. CLS. 21, 23, 26, 36 AND 38).

FIRST USE 9-1-1989; IN COMMERCE 9-1-1989.
WENDY GOODMAN, EXAMINING ATTORNEY

SN 85-314,891. BALLY GAMING, INC., DBA BALLY TECHNOLOGIES, LAS VEGAS, NV. FILED 5-6-2011.

KING'S JEWELS

THE MARK CONSISTS OF STANDARD CHARACTERS WITHOUT CLAIM TO ANY PARTICULAR FONT, STYLE, SIZE, OR COLOR.

FOR GAMING MACHINES, NAMELY, DEVICES WHICH ACCEPT A WAGER AND GAMING SOFTWARE THAT GENERATES OR DISPLAYS OUTCOMES FOR GAMING MACHINES (U.S. CLS. 21, 23, 26, 36 AND 38).

WENDY GOODMAN, EXAMINING ATTORNEY

CLASS 9—(Continued).

SN 85-314,899. BALLY GAMING, INC., DBA BALLY TECHNOLOGIES, LAS VEGAS, NV. FILED 5-6-2011.

DEEP SEA PEARL

THE MARK CONSISTS OF STANDARD CHARACTERS WITHOUT CLAIM TO ANY PARTICULAR FONT, STYLE, SIZE, OR COLOR.

FOR GAMING MACHINES, NAMELY, DEVICES WHICH ACCEPT A WAGER AND GAMING SOFTWARE THAT GENERATES OR DISPLAYS OUTCOMES FOR GAMING MACHINES (U.S. CLS. 21, 23, 26, 36 AND 38).

WENDY GOODMAN, EXAMINING ATTORNEY

SN 85-314,957. BALLY GAMING, INC., DBA BALLY TECHNOLOGIES, LAS VEGAS, NV. FILED 5-6-2011.

HATCH THE CASH

THE MARK CONSISTS OF STANDARD CHARACTERS WITHOUT CLAIM TO ANY PARTICULAR FONT, STYLE, SIZE, OR COLOR.

NO CLAIM IS MADE TO THE EXCLUSIVE RIGHT TO USE "CASH", APART FROM THE MARK AS SHOWN.

FOR GAMING MACHINES, NAMELY, DEVICES WHICH ACCEPT A WAGER AND GAMING SOFTWARE THAT GENERATES OR DISPLAYS OUTCOMES FOR GAMING MACHINES (U.S. CLS. 21, 23, 26, 36 AND 38).

FIRST USE 5-15-2007; IN COMMERCE 5-15-2007.

WENDY GOODMAN, EXAMINING ATTORNEY

SN 85-315,948. HILL-ROM SERVICES, INC., BATESVILLE, IN. FILED 5-9-2011.

SMARTCONNECT

THE MARK CONSISTS OF STANDARD CHARACTERS WITHOUT CLAIM TO ANY PARTICULAR FONT, STYLE, SIZE, OR COLOR.

FOR INTEGRATED ELECTRICAL PLUG DEVICE ENABLING CONNECTION AND DISCONNECTION OF POWER AND/OR COMMUNICATION CABLES FOR USE WITH MEDICAL EQUIPMENT (U.S. CLS. 21, 23, 26, 36 AND 38).

CYNTHIA SLOAN, EXAMINING ATTORNEY

CLASS 9—(Continued).

SN 85-315,958. HILL-ROM SERVICES, INC., BATESVILLE, IN. FILED 5-9-2011.

SMARTSYNC

THE MARK CONSISTS OF STANDARD CHARACTERS WITHOUT CLAIM TO ANY PARTICULAR FONT, STYLE, SIZE, OR COLOR.

FOR COMPUTER HARDWARE AND SOFTWARE FOR MEDICAL DATA COLLECTION, STORAGE, DISPLAY AND TRANSMISSION; COMMUNICATIONS HARDWARE AND SOFTWARE FOR TRANSMISSION AND EXCHANGE OF MEDICAL DATA (U.S. CLS. 21, 23, 26, 36 AND 38).

CYNTHIA SLOAN, EXAMINING ATTORNEY

SN 85-315,965. CHECKPOINT SYSTEMS, INC., PHILADELPHIA, PA. FILED 5-9-2011.



THE MARK CONSISTS OF A STYLIZED PADLOCK WITH STYLIZED SOUND WAVES EMITTING FROM EACH SIDE OF THE PADLOCK.

FOR ELECTRONIC SECURITY GATES AND ELECTRONIC SECURITY TAGS TO BE APPLIED TO RETAIL MERCHANDISE (U.S. CLS. 21, 23, 26, 36 AND 38).

FIRST USE 8-1-2010; IN COMMERCE 8-1-2010.

WILLIAM ROSSMAN, EXAMINING ATTORNEY

CLASS 9—(Continued).

SN 85-317,284. PRECIOUS MOMENTS, INCORPORATED, ROLLING MEADOWS, IL. FILED 5-10-2011.

STINK BUGS

THE MARK CONSISTS OF STANDARD CHARACTERS WITHOUT CLAIM TO ANY PARTICULAR FONT, STYLE, SIZE, OR COLOR.

FOR MUSICAL SOUND RECORDINGS; AUDIO-VISUAL RECORDINGS, NAMELY, COMPACT DISCS, TAPE CASSETTES, AUDIO CASSETTES, AUDIO TAPES, AUDIO DISCS, RECORDS, CD-ROMS, VIDEO TAPES, VIDEO CASSETTES, VIDEO DISCS, DVDS, DATS, MP3S, AND LASER DISCS, ALL FEATURING MUSIC; DOWNLOADABLE MUSICAL SOUND RECORDINGS; DOWNLOADABLE VIDEO RECORDINGS FEATURING MUSIC; DOWNLOADABLE ELECTRONIC PUBLICATIONS IN THE NATURE OF BOOKS, BOOKLETS, MAGAZINES, JOURNALS, MANUALS, BROCHURES, LEAFLETS, PAMPHLETS AND NEWSLETTERS, ALL IN THE FIELD OF MUSIC AND CHILDREN'S ENTERTAINMENT AND EDUCATION; ELECTRONIC PUBLICATIONS, NAMELY, BOOKS, BOOKLETS, MAGAZINES, JOURNALS, MANUALS, BROCHURES, LEAFLETS, PAMPHLETS AND NEWSLETTERS, ALL IN THE FIELD OF MUSIC AND CHILDREN'S ENTERTAINMENT AND EDUCATION, ALL RECORDED ON CD-ROMS, DISKETTES, FLOPPY DISKS, VIDEO CASSETTES, AND MAGNETIC TAPES; PROTECTIVE EYEWEAR; SUNGLASSES; EYEGLASSES; EYEGLASS FRAMES; SPECTACLES; EYEGLASS, SUNGLASS AND SPECTACLE CASES; EYEGLASS, SUNGLASS AND SPECTACLE STRAPS; EYEGLASS, SUNGLASS AND SPECTACLE CHAINS; MAGNETS; DECORATIVE MAGNETS; REFRIGERATOR MAGNETS; NOVELTY MAGNETS; MOUSE PADS; COMPACT DISC CASES; FITTED CASES FOR STORAGE AND TRANSPORTATION, NAMELY, CASES FOR COMPACT DISCS, AUDIO CASSETTES, VIDEO CASSETTES, CD-ROMS, HOME VIDEO GAMES, HOME VIDEO GAME ACCESSORIES, COMPUTERS, COMPUTER ACCESSORIES, CAMERAS, CAMCORDERS AND PORTABLE PHONES; COMPUTER CARRYING CASES; WRIST RESTS AND SUPPORTS FOR COMPUTER MOUSE USERS; WRIST RESTS FOR COMPUTERS; COMPUTER KEYBOARD WRIST PADS; BINOCULARS; SIGNAL AND SPORT WHISTLES; COMPUTER GAME SOFTWARE, CARTRIDGES, JOYSTICKS, CASSETTES, DISCS AND INSTRUCTION MANUALS SOLD AS A UNIT THEREWITH; COMPUTERIZED VIDEO TABLE GAMES FOR GAMING PURPOSES; ELECTRONIC GAME PROGRAMS; INTERACTIVE AUDIO GAME DISCS CONTAINING ROLE PLAYING GAME AND ACTION GAMES; INTERACTIVE VIDEO GAME PROGRAMS; INTERACTIVE MULTIMEDIA COMPUTER GAME PROGRAM; JOYSTICKS FOR VIDEO GAMES; MACHINES FOR PLAYING GAMES OF CHANCE; VIDEO GAME INTERACTIVE REMOTE CONTROL UNITS AND CONTROL FLOOR PADS OR MATS; VIDEO GAME MACHINES FOR USE WITH TELEVISIONS; VIDEO GAME OUTPUT MACHINES FOR USE WITH TELEVISIONS; VIRTUAL REALITY GAME SOFTWARE; DOWNLOADABLE MUSIC, RING TONES, GRAPHICS, AND ELECTRONIC GAMES VIA THE INTERNET AND WIRELESS DEVICES; DOWNLOADABLE WIRELESS GAME SOFTWARE; DOWNLOADABLE WIRELESS ENTERTAINMENT, NAMELY, RING TONES, SCREEN SAVERS AND IMAGES, AND WALLPAPER; DOWNLOADABLE RING-BACK TONES (U.S. CLS. 21, 23, 26, 36 AND 38).

JUDITH HELFMAN, EXAMINING ATTORNEY

CLASS 9—(Continued).

SN 85-317,847. YASKAWA AMERICA, INC., WAUKEGAN, IL. FILED 5-11-2011.



The logo for iQPUMP features the word "iQPUMP" in a bold, sans-serif font. The letter "Q" is significantly larger than the other letters and has a thick, wavy underline that extends across the width of the "i" and "P".

OWNER OF U.S. REG. NO. 3,412,254.

THE MARK CONSISTS OF THE WORDING, "iQPUMP" WITH A WAVE UNDERNEATH. THE LETTER "Q" IS LARGER THAN OTHER CHARACTERS.

FOR ELECTRONIC CONTROLLERS AND SOFTWARE USED TO CONTROL THE CURRENT OF ELECTRICAL MOTORS FOR USE ON PUMPS AND PUMP SYSTEMS (U.S. CLS. 21, 23, 26, 36 AND 38).

FIRST USE 3-1-2007; IN COMMERCE 3-1-2007.

CARYN GLASSER, EXAMINING ATTORNEY

SN 85-318,605. THE TOPPS COMPANY, INC., NEW YORK, NY. FILED 5-11-2011.



The logo for SHADOWRUN consists of the word "SHADOWRUN" in a bold, serif font.

THE MARK CONSISTS OF STANDARD CHARACTERS WITHOUT CLAIM TO ANY PARTICULAR FONT, STYLE, SIZE, OR COLOR.

OWNER OF U.S. REG. NO. 1,605,488.

FOR MOTION PICTURE FILMS FEATURING ENTERTAINMENT, NAMELY, COMEDY, DRAMA, ANIMATION, ROMANCE, SCIENCE FICTION, AND/OR ACTION/ADVENTURE; PRE-RECORDED AUDIO AND VIDEO TAPES, VIDEO DISCS AND DVDS FEATURING ENTERTAINMENT, NAMELY, COMEDY, DRAMA, ANIMATION, ROMANCE, SCIENCE FICTION, AND/OR ACTION/ADVENTURE; MUSICAL SOUND RECORDINGS; AND PRERECORDED AUDIO TAPES AND PRE-RECORDED COMPACT DISCS FEATURING MUSIC; DOWNLOADABLE AUDIO AND VIDEO RECORDINGS, DIGITAL MEDIA, MP3 FILES, MP3 RECORDINGS, PODCASTS, ON-LINE DISCUSSION BOARDS, WEBCASTS, AND AUDIO BOOKS IN THE FIELD OF MUSIC, COMEDY, DRAMA, ANIMATION, ROMANCE, SCIENCE FICTION, AND/OR ACTION/ADVENTURE (U.S. CLS. 21, 23, 26, 36 AND 38).

EDWARD FENNESSY, EXAMINING ATTORNEY

CLASS 9—(Continued).

SN 85-318,761. GREENMASTER INDUSTRIAL CORP., TAI-CHUNG, TAIWAN, FILED 5-12-2011.



The logo for fit • do • be consists of the words "fit", "do", and "be" in a lowercase, sans-serif font, separated by small black dots.

THE MARK CONSISTS OF THREE WORDS "FIT", "DO" AND "BE" IN LOWER CASE FONT, AND TWO DOTS, ONE SITS IN THE MIDDLE BETWEEN WORDS "FIT" AND "DO", THE OTHER SITS IN THE MIDDLE BETWEEN WORDS "DO" AND "BE".

FOR COMPUTER CURSOR CONTROL DEVICES, NAMELY, TOUCH PADS; COMPUTER SOFTWARE AND HARDWARE FOR CONTROLLING EXERCISE MACHINE; ELECTRONIC BOOK READER; NOTEBOOK COMPUTERS; PERSONAL COMPUTERS; PERSONAL DIGITAL ASSISTANTS (PDA); POCKET COMPUTERS FOR NOTE-TAKING; TABLET COMPUTER; TOUCH PADS; TOUCH PANELS (U.S. CLS. 21, 23, 26, 36 AND 38).

MICHAEL ENGEL, EXAMINING ATTORNEY

SN 85-318,837. BLUBERI JEUX ET TECHNOLOGIES INC. AKA BLUBERI GAMING TECHNOLOGIES INC., DRUM-MONDEVILLE, QUEBEC, CANADA, FILED 5-12-2011.



The logo for DRIVE-IN ROUTE 77 consists of the words "DRIVE-IN ROUTE 77" in a bold, serif font.

THE MARK CONSISTS OF STANDARD CHARACTERS WITHOUT CLAIM TO ANY PARTICULAR FONT, STYLE, SIZE, OR COLOR.

FOR SOFTWARE FOR GAMING MACHINES; GAMING MACHINES WITH VIDEO OUTPUT (U.S. CLS. 21, 23, 26, 36 AND 38).

WILLIAM P. SHANAHAN, EXAMINING ATTORNEY

SN 85-318,957. HUAWEI TECHNOLOGIES CO., LTD., SHENZHEN, CHINA, FILED 5-12-2011.



The logo for HIKER consists of the word "HIKER" in a bold, serif font.

THE MARK CONSISTS OF STANDARD CHARACTERS WITHOUT CLAIM TO ANY PARTICULAR FONT, STYLE, SIZE, OR COLOR.

FOR MOBILE TELEPHONES; DIGITAL PHOTO FRAMES FOR DISPLAYING DIGITAL PICTURES, VIDEO CLIPS AND MUSIC; TABLET COMPUTERS; DIGITAL BOOK READERS; PERSONAL DIGITAL ASSISTANTS (PDA) (U.S. CLS. 21, 23, 26, 36 AND 38).

JULIE GUTTADAURO, EXAMINING ATTORNEY

CLASS 9—(Continued).

SN 85-318,964. HUAWEI TECHNOLOGIES CO., LTD., SHENZHEN, CHINA, FILED 5-12-2011.

VIKING

THE MARK CONSISTS OF STANDARD CHARACTERS WITHOUT CLAIM TO ANY PARTICULAR FONT, STYLE, SIZE, OR COLOR.

FOR MOBILE TELEPHONES; DIGITAL PHOTO FRAMES FOR DISPLAYING DIGITAL PICTURES, VIDEO CLIPS AND MUSIC; TABLET COMPUTERS; DIGITAL BOOK READERS; PERSONAL DIGITAL ASSISTANTS (PDA) (U.S. CLS. 21, 23, 26, 36 AND 38).
JULIE GUTTADAURO, EXAMINING ATTORNEY

SN 85-318,979. HUAWEI TECHNOLOGIES CO., LTD., SHENZHEN, CHINA, FILED 5-12-2011.

OAR

THE MARK CONSISTS OF STANDARD CHARACTERS WITHOUT CLAIM TO ANY PARTICULAR FONT, STYLE, SIZE, OR COLOR.

FOR MOBILE TELEPHONES; DIGITAL PHOTO FRAMES FOR DISPLAYING DIGITAL PICTURES, VIDEO CLIPS AND MUSIC; TABLET COMPUTERS; DIGITAL BOOK READERS; PERSONAL DIGITAL ASSISTANTS (PDA) (U.S. CLS. 21, 23, 26, 36 AND 38).
JULIE GUTTADAURO, EXAMINING ATTORNEY

SN 85-319,240. 1STDIBS.COM, INC., NEW YORK, NY. FILED 5-12-2011.

THE FRENCH RESISTANCE

THE MARK CONSISTS OF STANDARD CHARACTERS WITHOUT CLAIM TO ANY PARTICULAR FONT, STYLE, SIZE, OR COLOR.

FOR DOWNLOADABLE ELECTRONIC PUBLICATIONS IN THE NATURE OF JOURNALS IN THE FIELD OF COOKING (U.S. CLS. 21, 23, 26, 36 AND 38).
JAMES A. RAUEN, EXAMINING ATTORNEY

CLASS 9—(Continued).

SN 85-319,255. IGT, RENO, NV. FILED 5-12-2011.

CHILI CHASER

THE MARK CONSISTS OF STANDARD CHARACTERS WITHOUT CLAIM TO ANY PARTICULAR FONT, STYLE, SIZE, OR COLOR.

FOR GAMING MACHINES, NAMELY, DEVICES WHICH ACCEPT A WAGER (U.S. CLS. 21, 23, 26, 36 AND 38).

CARYN GLASSER, EXAMINING ATTORNEY

SN 85-320,073. EMERGENCY INFORMATION TECHNOLOGIES, LLC, TALLAHASSEE, FL. FILED 5-13-2011.

EMFOCARD

THE MARK CONSISTS OF STANDARD CHARACTERS WITHOUT CLAIM TO ANY PARTICULAR FONT, STYLE, SIZE, OR COLOR.

FOR ELECTRONIC STORAGE CARD FOR STORING PERSONAL MEDICAL INFORMATION AND EMERGENCY CONTACT INFORMATION (U.S. CLS. 21, 23, 26, 36 AND 38).

BRIAN NEVILLE, EXAMINING ATTORNEY

SN 85-320,488. STONE CREEK ENTERTAINMENT INC., RIDGEFIELD, CT. FILED 5-13-2011.

KARIZMAC LIFE BEAT

THE MARK CONSISTS OF STANDARD CHARACTERS WITHOUT CLAIM TO ANY PARTICULAR FONT, STYLE, SIZE, OR COLOR.

OWNER OF U.S. REG. NOS. 3,836,289, 3,862,189 AND 3,941,108.

FOR DOWNLOADABLE VIDEO GAME SOFTWARE FOR MOBILE DEVICES AND PERSONAL COMPUTERS (U.S. CLS. 21, 23, 26, 36 AND 38).

NELSON SNYDER, EXAMINING ATTORNEY

CLASS 9—(Continued).

SN 85-321,319. ALEXANDER ANDREW, INC., DBA FALL-TECH, COMPTON, CA. FILED 5-15-2011.

DEFENDER

THE MARK CONSISTS OF STANDARD CHARACTERS WITHOUT CLAIM TO ANY PARTICULAR FONT, STYLE, SIZE, OR COLOR.

FOR FALL PROTECTION EQUIPMENT FOR FALL RESTRAINT AND FALL ARREST, NAMELY, BARS, ANCHORS, HARNESES, LINES, LANYARDS, CARABINERS AND ANCHORAGE CONNECTORS; SAFETY EQUIPMENT, NAMELY, A LIFELINE SYSTEM FOR HORIZONTAL OR VERTICAL MOVEMENT TO WHICH A WORKER IS ATTACHED FOR PROTECTION AGAINST FALL HAZARDS, COMPOSED OF LINE TENSIONERS, SELF RETRACTING LIFELINES (SRL), AND RETRACTABLE DEVICES (U.S. CLS. 21, 23, 26, 36 AND 38).

SHAUNIA CARLYLE, EXAMINING ATTORNEY

SN 85-321,814. FERGUSON ENTERPRISES, INC., NEWPORT NEWS, VA. FILED 5-16-2011.

PROSELECT

THE MARK CONSISTS OF STANDARD CHARACTERS WITHOUT CLAIM TO ANY PARTICULAR FONT, STYLE, SIZE, OR COLOR.

OWNER OF U.S. REG. NOS. 3,065,212, 3,941,024 AND OTHERS.

FOR WATER HEATER PARTS, NAMELY HEATING CONTROLS AND THERMOSTATS (U.S. CLS. 21, 23, 26, 36 AND 38).

FIRST USE 12-1-2009; IN COMMERCE 12-1-2009.
KIM SAITO, EXAMINING ATTORNEY

SN 85-321,875. HUMANSCALE CORPORATION, NEW YORK, NY. FILED 5-16-2011.

HUMANSCALE

THE MARK CONSISTS OF STANDARD CHARACTERS WITHOUT CLAIM TO ANY PARTICULAR FONT, STYLE, SIZE, OR COLOR.

OWNER OF U.S. REG. NOS. 2,450,121, 3,916,742 AND OTHERS.

FOR COMPUTER SOFTWARE FOR USE IN MONITORING POINT-OF-CARE MEDICAL CARTS (U.S. CLS. 21, 23, 26, 36 AND 38).

FIRST USE 12-1-2009; IN COMMERCE 12-1-2009.
JAMES STEIN, EXAMINING ATTORNEY

CLASS 9—(Continued).

SN 85-321,994. NATIONAL INSTRUMENTS CORPORATION, AUSTIN, TX. FILED 5-16-2011.

THE SOFTWARE IS THE INSTRUMENT

THE MARK CONSISTS OF STANDARD CHARACTERS WITHOUT CLAIM TO ANY PARTICULAR FONT, STYLE, SIZE, OR COLOR.

FOR COMPUTER HARDWARE, NAMELY INTERFACE UNITS, AND COMPUTER SOFTWARE FOR USE IN THE FIELDS OF SCIENTIFIC AND ENGINEERING DATA ACQUISITION CONTROL AND ANALYSIS FOR DATA ACQUISITION AND PROCESSING OF ENGINEERING, SCIENTIFIC, AND INDUSTRIAL AUTOMATION DATA AND FOR ANALYZING INDUSTRIAL AUTOMATION DATA, AND FOR CONTROLLING AND EMULATING SCIENTIFIC AND ENGINEERING INSTRUMENTS AND INSTRUMENT SYSTEMS, AND FOR PERFORMING INSTRUMENTATION FUNCTIONS, AND INSTRUCTION MANUALS SOLD THEREWITH (U.S. CLS. 21, 23, 26, 36 AND 38).

FIRST USE 7-19-1988; IN COMMERCE 7-19-1988.
ANDREA HACK, EXAMINING ATTORNEY

SN 85-322,259. BALLY GAMING, INC., DBA BALLY TECHNOLOGIES, LAS VEGAS, NV. FILED 5-16-2011.

MONEY TALK

THE MARK CONSISTS OF STANDARD CHARACTERS WITHOUT CLAIM TO ANY PARTICULAR FONT, STYLE, SIZE, OR COLOR.

NO CLAIM IS MADE TO THE EXCLUSIVE RIGHT TO USE "MONEY", APART FROM THE MARK AS SHOWN.

FOR GAMING MACHINES, NAMELY, DEVICES WHICH ACCEPT A WAGER AND GAMING SOFTWARE THAT GENERATES OR DISPLAYS OUTCOMES FOR GAMING MACHINES (U.S. CLS. 21, 23, 26, 36 AND 38).

WENDY GOODMAN, EXAMINING ATTORNEY

CLASS 9—(Continued).

SN 85-322,396. COM2US CORPORATION, SEOUL, REPUBLIC OF KOREA, FILED 5-16-2011.

Tiny Farm

THE MARK CONSISTS OF STANDARD CHARACTERS WITHOUT CLAIM TO ANY PARTICULAR FONT, STYLE, SIZE, OR COLOR.

FOR COMPUTER GAME PROGRAMMES; COMPUTER GAME PROGRAMMES DOWNLOADABLE VIA THE INTERNET; COMPUTER GAME PROGRAMS; COMPUTER GAME SOFTWARE; COMPUTER GAME SOFTWARE DOWNLOADABLE FROM A GLOBAL COMPUTER NETWORK; COMPUTER GAME SOFTWARE FOR USE ON MOBILE AND CELLULAR PHONES; DOWNLOADABLE COMPUTER GAME PROGRAMS; DOWNLOADABLE COMPUTER GAME SOFTWARE VIA A GLOBAL COMPUTER NETWORK AND WIRELESS DEVICES; DOWNLOADABLE ELECTRONIC GAME PROGRAMS; ELECTRONIC GAME PROGRAMS; ELECTRONIC GAME SOFTWARE; ELECTRONIC GAME SOFTWARE FOR CELLULAR TELEPHONES; ELECTRONIC GAME SOFTWARE FOR HANDHELD ELECTRONIC DEVICES; ELECTRONIC GAME SOFTWARE FOR WIRELESS DEVICES; GAME SOFTWARE; INTERACTIVE GAME PROGRAMS; INTERACTIVE GAME SOFTWARE; INTERACTIVE VIDEO GAME PROGRAMS; VIDEO AND COMPUTER GAME PROGRAMS (U.S. CLS. 21, 23, 26, 36 AND 38).

INGRID C. EULIN, EXAMINING ATTORNEY

SN 85-323,890. USES MFG INC., QUAKER HILL, CT. FILED 5-18-2011.

XL

THE MARK CONSISTS OF STANDARD CHARACTERS WITHOUT CLAIM TO ANY PARTICULAR FONT, STYLE, SIZE, OR COLOR.

FOR POWER LINE CONDITIONERS (U.S. CLS. 21, 23, 26, 36 AND 38).

MARLENE BELL, EXAMINING ATTORNEY

SN 85-323,912. USES MFG INC., QUAKER HILL, CT. FILED 5-18-2011.

XL ULTRA

THE MARK CONSISTS OF STANDARD CHARACTERS WITHOUT CLAIM TO ANY PARTICULAR FONT, STYLE, SIZE, OR COLOR.

FOR POWER LINE CONDITIONERS (U.S. CLS. 21, 23, 26, 36 AND 38).

MARLENE BELL, EXAMINING ATTORNEY

CLASS 9—(Continued).

SN 85-323,992. IGT, RENO, NV. FILED 5-18-2011.

PEARL DRAGON

THE MARK CONSISTS OF STANDARD CHARACTERS WITHOUT CLAIM TO ANY PARTICULAR FONT, STYLE, SIZE, OR COLOR.

FOR GAMING MACHINES, NAMELY, DEVICES WHICH ACCEPT A WAGER (U.S. CLS. 21, 23, 26, 36 AND 38).

CARYN GLASSER, EXAMINING ATTORNEY

SN 85-325,211. BALLY GAMING, INC., DBA BALLY TECHNOLOGIES, LAS VEGAS, NV. FILED 5-19-2011.

STRING OF PEARLS

THE MARK CONSISTS OF STANDARD CHARACTERS WITHOUT CLAIM TO ANY PARTICULAR FONT, STYLE, SIZE, OR COLOR.

FOR GAMING MACHINES, NAMELY, DEVICES WHICH ACCEPT A WAGER AND GAMING SOFTWARE THAT GENERATES OR DISPLAYS OUTCOMES FOR GAMING MACHINES (U.S. CLS. 21, 23, 26, 36 AND 38).

WENDY GOODMAN, EXAMINING ATTORNEY

SN 85-325,314. IND GROUP, LOS ANGELES, CA. FILED 5-19-2011.

KDGT

THE MARK CONSISTS OF STANDARD CHARACTERS WITHOUT CLAIM TO ANY PARTICULAR FONT, STYLE, SIZE, OR COLOR.

FOR AUDIO SPEAKERS; EARPHONES AND HEADPHONES; MP3 PLAYERS (U.S. CLS. 21, 23, 26, 36 AND 38).

HEATHER SAPP, EXAMINING ATTORNEY

CLASS 9—(Continued).

SN 85-325,750. STYLEMARK, INC., ORMOND BEACH, FL. FILED 5-20-2011.

3D POWERVISION

THE MARK CONSISTS OF STANDARD CHARACTERS WITHOUT CLAIM TO ANY PARTICULAR FONT, STYLE, SIZE, OR COLOR.

NO CLAIM IS MADE TO THE EXCLUSIVE RIGHT TO USE "3D", APART FROM THE MARK AS SHOWN.

FOR SUNGLASSES; SUNGLASS LENSES; EYEGLASSES; EYEGLASS LENSES; EYEGLASS AND SUNGLASS FRAMES; READING GLASSES; AND THREE-DIMENSIONAL VIEWING GLASSES (U.S. CLS. 21, 23, 26, 36 AND 38).

SAIMA MAKHDOOM, EXAMINING ATTORNEY

SN 85-325,879. BALLY GAMING, INC., DBA BALLY TECHNOLOGIES, LAS VEGAS, NV. FILED 5-20-2011.

WHITE FIRE

THE MARK CONSISTS OF STANDARD CHARACTERS WITHOUT CLAIM TO ANY PARTICULAR FONT, STYLE, SIZE, OR COLOR.

FOR GAMING MACHINES, NAMELY, DEVICES WHICH ACCEPT A WAGER AND GAMING SOFTWARE THAT GENERATES OR DISPLAYS OUTCOMES FOR GAMING MACHINES (U.S. CLS. 21, 23, 26, 36 AND 38).

FIRST USE 11-3-2010; IN COMMERCE 11-3-2010.
WENDY GOODMAN, EXAMINING ATTORNEY

SN 85-326,192. LIVE NATION WORLDWIDE, INC., BEVERLY HILLS, CA. FILED 5-20-2011.

VENUE NATION

THE MARK CONSISTS OF STANDARD CHARACTERS WITHOUT CLAIM TO ANY PARTICULAR FONT, STYLE, SIZE, OR COLOR.

FOR PRE-RECORDED CDS, AUDIO CASSETTES, VIDEO CASSETTES, DVDS, SOUND FILES, AND DIGITAL STORAGE DEVICES, NAMELY, MP3 PLAYERS AND FLASH DRIVES, ALL FEATURING MUSICAL PERFORMANCES (U.S. CLS. 21, 23, 26, 36 AND 38).

DAVID HOFFMAN, EXAMINING ATTORNEY

CLASS 9—(Continued).

SN 85-326,873. BROADVIEW NETWORKS, INC., RYE BROOK, NY. FILED 5-22-2011.



OWNER OF U.S. REG. NO. 2,957,599.
THE MARK CONSISTS OF A LIGHT SQUARE OFFSET WITHIN A DARK SQUARE WITH A PROJECTION ORIGINATING FROM THE RIGHT AND LOWER EDGES OF THE LIGHT SQUARE; THE PROJECTION IS ORIENTED DOWNWARD AND TO THE RIGHT SIDE OF THE MARK INTERSECTING A PORTION OF THE WORD "SILHOUETTE" BELOW THE SQUARES SO THAT A MIRROR-LIKE IMAGE OF THE LETTERS "UETT" APPEARS AT THE END OF THE PROJECTION BELOW THE WORD "SILHOUETTE".

FOR SOFTWARE FOR TELEPHONY AND MESSAGING SYSTEMS FOR THE PURPOSE OF DELIVERING VOICE, DATA, CALL MANAGEMENT, DIRECTORY, MESSAGING AND EMAIL SERVICES (U.S. CLS. 21, 23, 26, 36 AND 38).

JEFFERY COWARD, EXAMINING ATTORNEY

SN 85-327,005. BROADVIEW NETWORKS, INC., RYE BROOK, NY. FILED 5-23-2011.



THE MARK CONSISTS OF A LIGHT SQUARE OFFSET WITHIN A DARK SQUARE WITH A PROJECTION ORIGINATING FROM THE RIGHT AND LOWER EDGES OF THE LIGHT SQUARE; THE PROJECTION IS ORIENTED DOWNWARD AND TO THE RIGHT SIDE OF THE MARK.

FOR SOFTWARE FOR TELEPHONY AND MESSAGING SYSTEMS FOR THE PURPOSE OF DELIVERING VOICE, DATA, CALL MANAGEMENT, DIRECTORY, MESSAGING AND EMAIL SERVICES (U.S. CLS. 21, 23, 26, 36 AND 38).

JEFFERY COWARD, EXAMINING ATTORNEY

CLASS 9—(Continued).

SN 85-327,876. UNIVERSAL ENTERTAINMENT CORPORATION, KOTO-KU, TOKYO, JAPAN, FILED 5-23-2011.



THE MARK CONSISTS OF WORD "INNOVATOR" WITH BLOCK OUTLINE AND TWO STAR DESIGNS ON THE TOP AND TWO STAR DESIGNS ON THE BOTTOM.

FOR SLOT MACHINES AND REPLACEMENT PARTS THEREFOR; VIDEO SLOT MACHINES AND REPLACEMENT PARTS THEREFOR; GAMING MACHINES AND REPLACEMENT PARTS THEREFOR; GAMING MACHINES WITH A LIQUID CRYSTAL DISPLAY AND REPLACEMENT PARTS THEREFOR; MECHANICAL REEL TYPE SLOT MACHINES WITH A LIQUID CRYSTAL DISPLAY AND REPLACEMENT PARTS THEREFOR; MEDIA STORAGE COMPUTER SOFTWARE FOR ELECTRONIC CIRCUITS, OPTICAL DISKS, MAGNETIC TAPES, MAGNETIC DISKS, MAGNETIC CARDS, OPTICAL-MAGNETIC DISKS, CD-ROMS, ROM-CARTRIDGES AND DVDS, NAMELY, COMPUTER SOFTWARE FOR CONTROLLING SLOT MACHINES AND GAME MACHINES; COMPUTER GAME SOFTWARE FOR GAME MACHINES AND SLOT MACHINES (U.S. CLS. 21, 23, 26, 36 AND 38).

ANTHONY RINKER, EXAMINING ATTORNEY

SN 85-328,752. THE FONT BUREAU, INC., BOSTON, MA. FILED 5-24-2011.

ROCKY

THE MARK CONSISTS OF STANDARD CHARACTERS WITHOUT CLAIM TO ANY PARTICULAR FONT, STYLE, SIZE, OR COLOR.

FOR PRINTING FONTS THAT CAN BE DOWNLOADED PROVIDED BY MEANS OF ELECTRONIC TRANSMISSION; TYPEFACE FONTS RECORDED ON MAGNETIC MEDIA (U.S. CLS. 21, 23, 26, 36 AND 38).

FIRST USE 11-15-2006; IN COMMERCE 11-15-2006.
GIANCARLO CASTRO, EXAMINING ATTORNEY

CLASS 9—(Continued).

SN 85-329,114. WILLOW GARAGE, INC., MENLO PARK, CA. FILED 5-24-2011.

POINT CLOUD LIBRARY (PCL)

THE MARK CONSISTS OF STANDARD CHARACTERS WITHOUT CLAIM TO ANY PARTICULAR FONT, STYLE, SIZE, OR COLOR.

NO CLAIM IS MADE TO THE EXCLUSIVE RIGHT TO USE "POINT CLOUD LIBRARY", APART FROM THE MARK AS SHOWN.

FOR COMPUTER SOFTWARE FOR USE IN CONTROLLING AND OPERATING ROBOTIC SYSTEMS (U.S. CLS. 21, 23, 26, 36 AND 38).

IRA J. GOODSaid, EXAMINING ATTORNEY

SN 85-329,247. BALLY GAMING, INC., DBA BALLY TECHNOLOGIES, LAS VEGAS, NV. FILED 5-24-2011.

DIAMOND LINE

THE MARK CONSISTS OF STANDARD CHARACTERS WITHOUT CLAIM TO ANY PARTICULAR FONT, STYLE, SIZE, OR COLOR.

OWNER OF U.S. REG. NO. 3,090,347.

FOR GAMING MACHINES, NAMELY, DEVICES WHICH ACCEPT A WAGER AND GAMING SOFTWARE THAT GENERATES OR DISPLAYS OUTCOMES FOR GAMING MACHINES (U.S. CLS. 21, 23, 26, 36 AND 38).

FIRST USE 1-5-2010; IN COMMERCE 1-5-2010.

WENDY GOODMAN, EXAMINING ATTORNEY

SN 85-329,276. BALLY GAMING, INC., DBA BALLY TECHNOLOGIES, LAS VEGAS, NV. FILED 5-24-2011.

DOUBLE DYNAMO 7S

THE MARK CONSISTS OF STANDARD CHARACTERS WITHOUT CLAIM TO ANY PARTICULAR FONT, STYLE, SIZE, OR COLOR.

NO CLAIM IS MADE TO THE EXCLUSIVE RIGHT TO USE "7S", APART FROM THE MARK AS SHOWN.

FOR GAMING MACHINES, NAMELY, DEVICES WHICH ACCEPT A WAGER AND GAMING SOFTWARE THAT GENERATES OR DISPLAYS OUTCOMES FOR GAMING MACHINES (U.S. CLS. 21, 23, 26, 36 AND 38).

FIRST USE 6-1-2010; IN COMMERCE 6-1-2010.

WENDY GOODMAN, EXAMINING ATTORNEY

CLASS 9—(Continued).

SN 85-329,315. BALLY GAMING, INC., DBA BALLY TECHNOLOGIES, LAS VEGAS, NV. FILED 5-24-2011.

PERFECT 8

THE MARK CONSISTS OF STANDARD CHARACTERS WITHOUT CLAIM TO ANY PARTICULAR FONT, STYLE, SIZE, OR COLOR.

NO CLAIM IS MADE TO THE EXCLUSIVE RIGHT TO USE "8", APART FROM THE MARK AS SHOWN.

FOR GAMING MACHINES, NAMELY, DEVICES WHICH ACCEPT A WAGER AND GAMING SOFTWARE THAT GENERATES OR DISPLAYS OUTCOMES FOR GAMING MACHINES (U.S. CLS. 21, 23, 26, 36 AND 38).
WENDY GOODMAN, EXAMINING ATTORNEY

SN 85-333,873. SAMSUNG ELECTRONICS CO., LTD., SUWON-SI, GYEONGGI-DO, REPUBLIC OF KOREA, FILED 5-31-2011.

LANCE

THE MARK CONSISTS OF STANDARD CHARACTERS WITHOUT CLAIM TO ANY PARTICULAR FONT, STYLE, SIZE, OR COLOR.

FOR MOBILE PHONES; SMARTPHONES (U.S. CLS. 21, 23, 26, 36 AND 38).

TINA BROWN, EXAMINING ATTORNEY

SN 85-339,554. NINTENDO OF AMERICA INC., REDMOND, WA. FILED 6-7-2011.

KIRBY MASS ATTACK

THE MARK CONSISTS OF STANDARD CHARACTERS WITHOUT CLAIM TO ANY PARTICULAR FONT, STYLE, SIZE, OR COLOR.

FOR CARTRIDGES, MEMORY CARDS AND OTHER STORAGE MEDIA, NAMELY, FLASH MEMORY, FEATURING ENTERTAINMENT, EDUCATIONAL AND INFORMATIONAL CONTENT, NAMELY, VIDEO GAMES, PUZZLES, MUSIC AND STORIES; DOWNLOADABLE MULTIMEDIA FILES, NAMELY, VIDEO GAMES; DOWNLOADABLE ELECTRONIC GAME PROGRAMS; DOWNLOADABLE ELECTRONIC GAME SOFTWARE; ELECTRONIC GAME PROGRAMS; ELECTRONIC GAME SOFTWARE; VIDEO GAME CARTRIDGES; VIDEO GAME MEMORY CARDS; VIDEO GAME PROGRAMS; VIDEO GAME SOFTWARE (U.S. CLS. 21, 23, 26, 36 AND 38).
B. PARADEWELAI, EXAMINING ATTORNEY

CLASS 9—(Continued).

SN 85-975,417. STREAM TV NETWORKS, INC., PHILADELPHIA, PA. FILED 8-6-2010.

ELOCITY

THE MARK CONSISTS OF STANDARD CHARACTERS WITHOUT CLAIM TO ANY PARTICULAR FONT, STYLE, SIZE, OR COLOR.

FOR TABLET COMPUTERS (U.S. CLS. 21, 23, 26, 36 AND 38).

FIRST USE 9-8-2010; IN COMMERCE 9-8-2010.
MATTHEW EINSTEIN, EXAMINING ATTORNEY

CLASS 10—MEDICAL APPARATUS

SN 76-704,215. SYMMETRY MEDICAL, INC., WARSAW, IN. FILED 8-23-2010.



NO CLAIM IS MADE TO THE EXCLUSIVE RIGHT TO USE "MEDICAL", APART FROM THE MARK AS SHOWN.

FOR STERILIZATION UNITS FOR MEDICAL PURPOSES AND RELATED ACCESSORIES, NAMELY, STORAGE CONTAINERS AND TRAYS (U.S. CLS. 26, 39 AND 44).

JOSETTE BEVERLY, EXAMINING ATTORNEY

SN 77-832,356. PHASE C INC., HENDERSON, NV. FILED 9-22-2009.

iBrator

THE MARK CONSISTS OF STANDARD CHARACTERS WITHOUT CLAIM TO ANY PARTICULAR FONT, STYLE, SIZE, OR COLOR.

FOR ADULT SEXUAL STIMULATION AIDS, NAMELY, VIBRATORS (U.S. CLS. 26, 39 AND 44).

RONALD DELGIZZI, EXAMINING ATTORNEY

CLASS 10—(Continued).

SN 77-848,340. SULZER MIXPAC AG, HAAG (RHEINTAL), SWITZERLAND, FILED 10-14-2009.

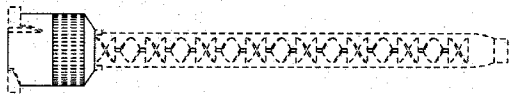

OWNER OF U.S. REG. NOS. 3,762,232 AND 3,762,233.

THE MARK CONSISTS OF THE CONFIGURATION OF A FUTURISTIC, DOME-FACADE TIP HAVING A SMOOTH BOTTOM PORTION, A SLIGHTLY INDENTED MIDDLE PORTION, AN UPPER PORTION ANGLED INWARDLY WHICH NARROWS AND RESTRICTS TO A TOP PORTION THAT ATTACHES TO A TRANSPARENT STEM WHICH ENCASES A CORKSCREW LIKE ELEMENT. THE DOTTED OUTLINE OF THE BOTTOM TAB AND TOP TABS ON THE DOME-FACADE TIP, THE SLIGHTLY INDENTED MIDDLE PORTION CONSISTING OF UNIFORM CONTINUOUS RIDGES, THE STEM AND THE CORKSCREW LIKE ELEMENT IS INTENDED TO SHOW POSITION OF THE MARK ON THE GOODS AND IS NOT PART OF THE MARK.

SEC. 2(F).

FOR MIXING TIPS USED WITH DISPENSERS OF TWO PART COMPOSITIONS FOR DENTAL APPLICATIONS (U.S. CLS. 26, 39 AND 44).

FIRST USE 12-31-1997; IN COMMERCE 12-31-1997.

ANN E. SAPPENFIELD, EXAMINING ATTORNEY

SN 77-934,921. OVESCO ENDOSCOPY AG, TUBINGEN, FED REP GERMANY, FILED 2-12-2010.

OTSC SYSTEM GOOD TO HAVE

THE MARK CONSISTS OF STANDARD CHARACTERS WITHOUT CLAIM TO ANY PARTICULAR FONT, STYLE, SIZE, OR COLOR.

NO CLAIM IS MADE TO THE EXCLUSIVE RIGHT TO USE "OTSC SYSTEM", APART FROM THE MARK AS SHOWN.

FOR ENDOSCOPIC EQUIPMENT; RIGID AND FLEXIBLE MEDICAL ENDOSCOPES (U.S. CLS. 26, 39 AND 44).

DAVID I, EXAMINING ATTORNEY

CLASS 10—(Continued).

SN 79-089,005. THD S.P.A., ITALY, FILED 9-14-2010.

GATEKEEPER

THE MARK CONSISTS OF STANDARD CHARACTERS WITHOUT CLAIM TO ANY PARTICULAR FONT, STYLE, SIZE, OR COLOR.

PRIORITY DATE OF 8-31-2010 IS CLAIMED.

OWNER OF INTERNATIONAL REGISTRATION 1055723 DATED 9-14-2010, EXPIRES 9-14-2020.

OWNER OF U.S. REG. NO. 2,988,007.

FOR SURGICALLY IMPLANTABLE PROSTHESIS FOR INTERNAL USE, NAMELY, BULKING AGENT TO BE IMPLANTED IN THE PROXIMITY OF ANAL CANAL OR URINARY CANAL OR GASTROESOPHAGEAL CANAL; ENDOPROSTHESIS; REVISION PROSTHESIS, NAMELY, BULKING AGENT TO BE IMPLANTED IN THE PROXIMITY OF ANAL CANAL OR URINARY CANAL OR GASTROESOPHAGEAL CANAL; SURGICAL APPARATUS AND INSTRUMENTS; DIAGNOSTIC DEVICES, NAMELY, VAGINAL AND ANAL DILATORS OR ANOSCOPES OR PROCTOSCOPES; SURGICAL PROBES; ENDOPROSTHESIS IMPLANTATION INSTRUMENTS (U.S. CLS. 26, 39 AND 44).

CORY BOONE, EXAMINING ATTORNEY

SN 79-089,064. VYGON, ECOUEN, FRANCE, FILED 9-16-2010.

QimoNo

THE MARK CONSISTS OF STANDARD CHARACTERS WITHOUT CLAIM TO ANY PARTICULAR FONT, STYLE, SIZE, OR COLOR.

PRIORITY DATE OF 3-17-2010 IS CLAIMED.

OWNER OF INTERNATIONAL REGISTRATION 1055941 DATED 9-16-2010, EXPIRES 9-16-2020.

THE WORD(S) "QIMONO" HAS NO MEANING IN A FOREIGN LANGUAGE.

FOR SURGICAL INSTRUMENTS, NAMELY, VALVES FOR CATHETERS, SURGICAL PERFORATORS, CATHETERISM ACCESSORIES, NAMELY, CONNECTORS AND FOLLOWERS FOR PREPARATION AND PERFUSION (U.S. CLS. 26, 39 AND 44).

KATHY DE JONGE, EXAMINING ATTORNEY

CLASS 10—(Continued).

SN 79-089,134. VYGON, ECOUEN, FRANCE, FILED 9-16-2010.

Qimo

THE MARK CONSISTS OF STANDARD CHARACTERS WITHOUT CLAIM TO ANY PARTICULAR FONT, STYLE, SIZE, OR COLOR.

PRIORITY DATE OF 3-17-2010 IS CLAIMED.

OWNER OF INTERNATIONAL REGISTRATION 1056098 DATED 9-16-2010, EXPIRES 9-16-2020.

THE WORD(S) "QIMO" HAS NO MEANING IN A FOREIGN LANGUAGE.

FOR SURGICAL INSTRUMENTS, NAMELY, VALVES FOR CATHETERS, CATHETERISM ACCESSORIES, NAMELY, BI-DIRECTIONAL CONNECTORS, CLOSED SYSTEM, NEEDLE-FREE, MALE AND FEMALE CATHETER CONNECTORS (U.S. CLS. 26, 39 AND 44).

KATHY DE JONGE, EXAMINING ATTORNEY

SN 79-089,785. SGD S.A., FRANCE, FILED 10-11-2010.

BABY FRIENDS

THE MARK CONSISTS OF STANDARD CHARACTERS WITHOUT CLAIM TO ANY PARTICULAR FONT, STYLE, SIZE, OR COLOR.

OWNER OF INTERNATIONAL REGISTRATION 1057757 DATED 10-11-2010, EXPIRES 10-11-2020.

NO CLAIM IS MADE TO THE EXCLUSIVE RIGHT TO USE "BABY", APART FROM THE MARK AS SHOWN.

FOR FEEDING BOTTLES (U.S. CLS. 26, 39 AND 44).

RONALD MCMORROW, EXAMINING ATTORNEY

SN 79-094,317. JAPAN MEDICAL MATERIALS CORPORATION, JAPAN, FILED 12-28-2010.

Aquala

THE MARK CONSISTS OF STANDARD CHARACTERS WITHOUT CLAIM TO ANY PARTICULAR FONT, STYLE, SIZE, OR COLOR.

OWNER OF INTERNATIONAL REGISTRATION 1069025 DATED 12-28-2010, EXPIRES 12-28-2020.

FOR ARTIFICIAL SURGICAL IMPLANTS, NAMELY, TOTAL HIP REPLACEMENTS, TOTAL KNEE PROSTHESES, ARTIFICIAL JOINTS, ARTIFICIAL BONES; STEMS FOR ARTIFICIAL JOINTS; CUPS FOR ARTIFICIAL JOINTS; SHELLS FOR ARTIFICIAL JOINTS; CUSHION LINERS FOR ARTIFICIAL JOINTS; MEDICAL MACHINES, APPARATUS AND INSTRUMENTS, NAMELY, ORTHOPEDIC FIXATION DEVICES USED IN ORTHOPEDIC TRANSPLANT AND/OR IMPLANT SURGERY, AND THEIR PARTS AND FITTINGS (U.S. CLS. 26, 39 AND 44).

SCOTT BIBB, EXAMINING ATTORNEY

CLASS 10—(Continued).

SN 79-095,039. ALBERT HOHLKÖRPER GMBH & CO. KG, FED REP GERMANY, FILED 6-28-2010.



OWNER OF INTERNATIONAL REGISTRATION 0737875 DATED 6-26-2000, EXPIRES 6-26-2020.

THE MARK CONSISTS OF A STYLIZED LETTER "A".

FOR SURGICAL APPARATUS AND INSTRUMENTS FOR MEDICAL, DENTAL AND VETERINARY USE; ARTIFICIAL LIMBS, EYES AND TEETH; ORTHOPEDIC ARTICLES, NAMELY, SUPPORTS, BRACES, BELTS, FOOTWEAR, JOINT IMPLANTS, CUSHIONS; SUTURE MATERIALS; MEDICAL DEVICES, NAMELY, DEVICES FOR OTOSCOPY, STETHOSCOPES, SYRINGES SOLD EMPTY, BLOOD PRESSURE MEASURING APPARATUS, ATOMIZER BULBS FOR SPRAYING LIQUIDS, SUCTION BULBS USED FOR MEDICAL PURPOSES, BLOOD PRESSURE BULBS, DOUCHE BULBS, DOUCHES, TRAVEL DOUCHES, IRRIGATION BULBS, MEDICAL IRRIGATORS, INFUSION BULBS, INFLATION BULBS, ATOMIZER BULBS, MASSAGE BULBS, ENEMA BULBS, ENEMA APPARATUS, RECTAL SYRINGES, DOUBLE BELLO BREAST PUMPS FOR MILK, INFUSION PUMPS FOR DELIVERING MEASURED AMOUNTS OF SOLUTIONS INTO THE BLOODSTREAM OVER TIME, VACUUM PUMPS FOR MEDICAL PURPOSES, IN LINE PUMPS, FOOT PUMPS, MEDICAL ASPIRATORS USED TO REMOVE BODY FLUIDS FROM A PATIENT, ULCER SYRINGES, ARTIFICIAL CARDIAC VALVES, HEALTH MONITORING DEVICES, NAMELY, BLOOD PRESSURE MONITORS, THERMOMETERS, AND PEDOMETERS, STOPCOCKS SOLD AS PART OF A MEDICAL APPARATUS, DOUBLE BELLOWS SOLD AS PART OF A MEDICAL APPARATUS, SINGLE USE BELLOWS SOLD AS PART OF A MEDICAL APPARATUS, AIR BLOWERS SOLD AS PART OF MEDICAL APPARATUS; AEROSOL DISPENSERS FOR MEDICAL PURPOSES; MEDICAL DEVICES FOR ANALYZING BREATH GASES FOR MEDICAL DIAGNOSTICS, FLOW CYTOMETERS AND FLOW BASED ANALYZERS PROVIDING CELL AND PARTICLE ANALYSIS, DETECTION, OR COUNTING FOR MEDICAL, CLINICAL, MEDICAL DIAGNOSTIC AND THERAPEUTIC USE, HEMATOLOGY ANALYZERS FOR MEDICAL DIAGNOSTIC USE; CONTAINERS, NAMELY, DROPPERS SOLD EMPTY FOR ADMINISTERING MEDICINES; FEEDING BOTTLES; ELASTIC BANDAGES; ORTHOPEDIC BANDAGES; RINGS TO FACILITATE TEETHING; HERNIA BANDAGES; SURGICAL IMPLANTS COMPRISING ARTIFICIAL MATERIAL; DRAINAGE TUBES FOR MEDICAL PURPOSES; FINGER-STALLS FOR MEDICAL PURPOSES; NASAL ASPIRATORS FOR USE TOGETHER WITH A TUBE AND BOTTLE FOR REMOVING MUCOUS FROM A PATIENT'S NASAL TRACT; HEARING PROTECTORS, NAMELY, HEARING AIDS; EAR PLUGS FOR MEDICAL PURPOSES, EAR SYRINGES; ORTHOPEDIC BELTS; GLOVES FOR MASSAGE; URINALS FOR MEDICAL PURPOSES; URETHRA TUBES; VIBRATING DEVICES FOR MEDICAL PURPOSES, NAMELY, MASSAGERS; INJECTORS FOR MEDICAL FLUIDS; INHALERS FOR MEDICAL PURPOSES; INJECTION SYRINGES CANNULAE; CATHETERS; AIR CUSHIONS FOR MEDICAL PURPOSES; CONDOMS; NON-CHEMICAL CONTRACEPTIVES; DEVICES FOR RINSING

CLASS 10—(Continued).

BODY CAVITIES; MEDICAL DEVICES FOR PHYSICAL EXERCISE, NAMELY, MANUALLY OPERATED EXERCISE EQUIPMENT FOR PHYSICAL THERAPY, VIBRATING APPARATUS USED TO STIMULATE MUSCLES AND INCREASE STRENGTH AND PHYSICAL PERFORMANCE FOR HEALTH AND MEDICAL PURPOSES; ARTIFICIAL LIMBS; MEDICINE SPOONS; MASSAGE DEVICES; MASSAGE GLOVES; PESSARIES; TEATS FOR BABIES; VIBRATING MASSAGE DEVICES; ICE BAGS FOR MEDICAL PURPOSES; HOT WATER BOTTLES FOR MEDICAL PURPOSES (U.S. CLS. 26, 39 AND 44).

STEVEN R. FINE, EXAMINING ATTORNEY

SN 79-098,192. KONINKLIJKE PHILIPS ELECTRONICS N.V., NETHERLANDS, FILED 5-20-2011.

GOLIFE

THE MARK CONSISTS OF STANDARD CHARACTERS WITHOUT CLAIM TO ANY PARTICULAR FONT, STYLE, SIZE, OR COLOR.

PRIORITY DATE OF 11-23-2010 IS CLAIMED. OWNER OF INTERNATIONAL REGISTRATION 1079498 DATED 5-20-2011, EXPIRES 5-20-2021.

FOR SURGICAL AND MEDICAL APPARATUS AND INSTRUMENTS, IN PARTICULAR RESPIRATORY MASKS FOR BREATHING (U.S. CLS. 26, 39 AND 44).
JANICE L. MCMORROW, EXAMINING ATTORNEY

SN 85-106,444. GUIDANCE ENDODONTICS, LLC, ALBUQUERQUE, NM. FILED 8-12-2010.

V-TAPER

THE MARK CONSISTS OF STANDARD CHARACTERS WITHOUT CLAIM TO ANY PARTICULAR FONT, STYLE, SIZE, OR COLOR.

FOR ENDODONTIC INSTRUMENTS (U.S. CLS. 26, 39 AND 44).

DOMINICK J. SALEMI, EXAMINING ATTORNEY

SN 85-112,149. HEALTHY FUNCTIONS, LLC, SPRING LAKE, NJ. FILED 8-20-2010.

CIRCSUPPORT

THE MARK CONSISTS OF STANDARD CHARACTERS WITHOUT CLAIM TO ANY PARTICULAR FONT, STYLE, SIZE, OR COLOR.

FOR MEDICAL THERAPEUTIC CUSHIONS FEATURING PRESSURE RELIEF MECHANISMS FOR BEDS, CHAIRS, AND WHEELCHAIRS (U.S. CLS. 26, 39 AND 44).

LESLEY LAMOTHE, EXAMINING ATTORNEY

CLASS 10—(Continued).

SN 85-112,156. HEALTHY FUNCTIONS, LLC, SPRING LAKE, NJ. FILED 8-20-2010.



THE MARK CONSISTS OF A STYLIZED "H", FOR MEDICAL THERAPEUTIC CUSHIONS FEATURING PRESSURE RELIEF MECHANISMS FOR BEDS, CHAIRS, AND WHEELCHAIRS (U.S. CLS. 26, 39 AND 44).

LESLEY LAMOTHE, EXAMINING ATTORNEY

SN 85-112,162. HEALTHY FUNCTIONS, LLC, SPRING LAKE, NJ. FILED 8-20-2010.

HEALTHY FUNCTIONS

THE MARK CONSISTS OF STANDARD CHARACTERS WITHOUT CLAIM TO ANY PARTICULAR FONT, STYLE, SIZE, OR COLOR.

FOR MEDICAL THERAPEUTIC CUSHIONS FEATURING PRESSURE RELIEF MECHANISMS FOR BEDS, CHAIRS, AND WHEELCHAIRS (U.S. CLS. 26, 39 AND 44).

LESLEY LAMOTHE, EXAMINING ATTORNEY

SN 85-127,769. CORDIS CORPORATION, BRIDGEWATER, NJ. FILED 9-13-2010.

CYPHER SONIX

THE MARK CONSISTS OF STANDARD CHARACTERS WITHOUT CLAIM TO ANY PARTICULAR FONT, STYLE, SIZE, OR COLOR.

OWNER OF U.S. REG. NOS. 2,782,642 AND 2,800,826. FOR MEDICAL DEVICES, NAMELY, STENTS (U.S. CLS. 26, 39 AND 44).

ROBERT C. CLARK JR., EXAMINING ATTORNEY

CLASS 10—(Continued).

SN 85-130,106. ERIC V. WADE, DDS, TYLER, TX. FILED 9-15-2010.

THE HAND PIECE GLOVE

THE MARK CONSISTS OF STANDARD CHARACTERS WITHOUT CLAIM TO ANY PARTICULAR FONT, STYLE, SIZE, OR COLOR.

NO CLAIM IS MADE TO THE EXCLUSIVE RIGHT TO USE "HAND PIECE", APART FROM THE MARK AS SHOWN.

FOR DENTAL INSTRUMENT PROTECTIVE COVER, NAMELY, A PLASTIC SLEEVE FOR USE ON HANDHELD OR MOUNTED DENTAL INSTRUMENTS (U.S. CLS. 26, 39 AND 44).

DEZMONA MIZELLE, EXAMINING ATTORNEY

SN 85-141,130. SDS MEDICAL SUPPLY, LLC, FRISCO, TX. FILED 9-29-2010.

SDS GLUTE STRAP

THE MARK CONSISTS OF STANDARD CHARACTERS WITHOUT CLAIM TO ANY PARTICULAR FONT, STYLE, SIZE, OR COLOR.

NO CLAIM IS MADE TO THE EXCLUSIVE RIGHT TO USE "GLUTE STRAP", APART FROM THE MARK AS SHOWN.

FOR MEDICAL DEVICES AND EQUIPMENT, NAMELY, NON-POWER OPERATED PATIENT TRANSFER AND FALL PREVENTION DEVICES IN THE NATURE OF BELTS FOR ASSISTING IN REDUCING PATIENT FALLS AND IN LIFTING AND MOVING PATIENTS (U.S. CLS. 26, 39 AND 44).

DEZMONA MIZELLE, EXAMINING ATTORNEY

SN 85-143,029. FREEDOM MEDITECH, INC., SAN DIEGO, CA. FILED 10-1-2010.

CLEARPATH DS-120

THE MARK CONSISTS OF STANDARD CHARACTERS WITHOUT CLAIM TO ANY PARTICULAR FONT, STYLE, SIZE, OR COLOR.

FOR NON-INVASIVE MEDICAL DEVICE USED TO DETECT OCULAR DEGRADATIONS THAT MAY CAUSE BLINDNESS, CATARACT OR OTHER CHRONIC DISEASE DUE TO ELEVATED FLUORESCENCE IN THE LENS OF THE EYE MEASURED AGAINST AGE RELATED FLUORESCENCE (U.S. CLS. 26, 39 AND 44).

JANICE KIM, EXAMINING ATTORNEY

CLASS 10—(Continued).

SN 85-143,039. FREEDOM MEDITECH, INC., SAN DIEGO, CA. FILED 10-1-2010.

I-SUGARX

THE MARK CONSISTS OF STANDARD CHARACTERS WITHOUT CLAIM TO ANY PARTICULAR FONT, STYLE, SIZE, OR COLOR.

FOR NON-INVASIVE MEDICAL DEVICE USED TO MONITOR CHANGING LEVELS OF GLUCOSE IN THE FLUIDS OF THE EYE (U.S. CLS. 26, 39 AND 44).

JANICE KIM, EXAMINING ATTORNEY

SN 85-156,720. FISHER & PAYKEL HEALTHCARE LIMITED, AUCKLAND 2013, NEW ZEALAND, FILED 10-20-2010.

ESON

THE MARK CONSISTS OF STANDARD CHARACTERS WITHOUT CLAIM TO ANY PARTICULAR FONT, STYLE, SIZE, OR COLOR.

PRIORITY CLAIMED UNDER SEC. 44(D) ON NEW ZEALAND APPLICATION NO. 829074, FILED 8-18-2010, REG. NO. 829074, DATED 8-18-2010, EXPIRES 8-18-2020.

FOR MEDICAL EQUIPMENT FOR THE PURPOSE OF DELIVERING OXYGEN OR HUMIDIFICATION THERAPY; HUMIDIFICATION APPARATUS FOR MEDICAL USE; MEDICAL APPARATUS FOR THE DIAGNOSIS AND TREATMENT OF OBSTRUCTIVE SLEEP APNEA; MEDICAL APPARATUS, NAMELY, INVASIVE AND NON-INVASIVE VENTILATION APPARATUS AND INSTRUMENTS; MEDICAL APPARATUS AND INSTRUMENTS FOR CONTINUOUS POSITIVE AIRWAY PRESSURE, ALSO KNOWN AS CPAP THERAPY; MEDICAL APPARATUS, NAMELY, HUMIDIFIERS AND METERS FOR POSITIVE AIRWAY PRESSURE THERAPY; BREATHING MASKS FOR USE IN TREATING OBSTRUCTIVE SLEEP APNEA; MEDICAL APPARATUS, NAMELY, SLEEP APNEA MONITORS; FACIAL MASKS, ORAL MASKS, NASAL MASKS, NASAL CANNULA, MOUTHPIECES, HEADGEAR, MEDICAL APPARATUS, NAMELY, BREATHING CIRCUITS, BREATHING TUBES, NASAL TUBES, TUBING CONNECTORS FOR MEDICAL USE, TUBING FOR MEDICAL USE, NASAL PRONGS, ALL BEING FOR MEDICAL PURPOSES; PARTS AND FITTINGS FOR ALL THE AFOREMENTIONED GOODS (U.S. CLS. 26, 39 AND 44).

DAWN HAN, EXAMINING ATTORNEY

CLASS 10—(Continued).

SN 85-159,527. AURUM CERAMIC DENTAL LABORATORIES LTD., CALGARY, ALBERTA, CANADA, FILED 10-22-2010.

PEARLITE

THE MARK CONSISTS OF STANDARD CHARACTERS WITHOUT CLAIM TO ANY PARTICULAR FONT, STYLE, SIZE, OR COLOR.
FOR DENTAL CROWNS AND DENTAL BRIDGES (U.S. CLS. 26, 39 AND 44).
JESSICA FATHY, EXAMINING ATTORNEY

CLASS 10—(Continued).

SN 85-228,475. OPTEC USA, INC., LAWRENCEVILLE, GA. FILED 1-28-2011.

VIPER

THE MARK CONSISTS OF STANDARD CHARACTERS WITHOUT CLAIM TO ANY PARTICULAR FONT, STYLE, SIZE, OR COLOR.
FOR ORTHOPEDIC SPINAL BRACES FOR MEDICAL USE, NAMELY, SPINAL BRACES WORN ON THE EXTERIOR OF THE BODY (U.S. CLS. 26, 39 AND 44).
SIMON TENG, EXAMINING ATTORNEY

SN 85-200,111. GAMMA MEDICA-IDEAS, INC., NORTH-RIDGE, CA. FILED 12-16-2010.

TRIUMPH

THE MARK CONSISTS OF STANDARD CHARACTERS WITHOUT CLAIM TO ANY PARTICULAR FONT, STYLE, SIZE, OR COLOR.
OWNER OF U.S. REG. NO. 3,369,475.
FOR MEDICAL IMAGING SYSTEMS, NAMELY, ELECTROMAGNETIC MEDICAL IMAGING APPARATUS AND INSTRUMENTS INCORPORATING MEDICAL IMAGING SOFTWARE, FOR MEDICAL IMAGING OF ANIMALS (U.S. CLS. 26, 39 AND 44).
MARIA-VICTORIA SUAREZ, EXAMINING ATTORNEY

SN 85-233,720. AMS RESEARCH CORPORATION, MINNETONKA, MN. FILED 2-3-2011.

GREENLIGHT XPS

THE MARK CONSISTS OF STANDARD CHARACTERS WITHOUT CLAIM TO ANY PARTICULAR FONT, STYLE, SIZE, OR COLOR.
OWNER OF U.S. REG. NOS. 2,955,963 AND 3,930,778.
SEC. 2(F) AS TO "GREENLIGHT".
FOR MEDICAL APPARATUS, NAMELY, LASERS FOR SURGICAL AND MEDICAL USE; FIBER OPTIC DELIVERY DEVICES FOR USE WITH LASERS FOR SURGICAL AND MEDICAL USE (U.S. CLS. 26, 39 AND 44).
FIRST USE 6-24-2010; IN COMMERCE 6-24-2010.
MARK T. MULLEN, EXAMINING ATTORNEY

SN 85-211,292. ORTHO DEVELOPMENT CORPORATION, DRAPER, UT. FILED 1-5-2011.

PAGODA

THE MARK CONSISTS OF STANDARD CHARACTERS WITHOUT CLAIM TO ANY PARTICULAR FONT, STYLE, SIZE, OR COLOR.
FOR ORTHOPEDIC IMPLANTS AND PROSTHESES, NAMELY, SPINAL IMPLANTS CONSISTING OF ARTIFICIAL MATERIALS AND PROSTHESES (U.S. CLS. 26, 39 AND 44).
TINA BROWN, EXAMINING ATTORNEY

SN 85-243,899. H 32, 75017 PARIS, FRANCE, FILED 2-16-2011.

HARMONY

THE MARK CONSISTS OF STANDARD CHARACTERS WITHOUT CLAIM TO ANY PARTICULAR FONT, STYLE, SIZE, OR COLOR.
FOR ORTHODONTIC APPARATUS AND INSTRUMENTS, NAMELY, ORTHODONTIC APPLIANCES AND ORTHODONTIC BRACKETS (U.S. CLS. 26, 39 AND 44).
LINDA ORNDORFF, EXAMINING ATTORNEY

CLASS 10—(Continued).

SN 85-251,859. DIGIACOMO, ROBERT, LAKE RONKONKO-
MA, NY. FILED 2-25-2011.

Mr. Squeakles

THE MARK CONSISTS OF STANDARD CHARACTERS
WITHOUT CLAIM TO ANY PARTICULAR FONT, STYLE,
SIZE, OR COLOR.

FOR PACIFIERS FOR BABIES; TEETHING RINGS;
TEETHING RINGS INCORPORATING BABY RATTLES;
PACIFIERS FOR BABIES; TEETHING RINGS; TEE-
THING RINGS INCORPORATING BABY RATTLES
(U.S. CLS. 26, 39 AND 44).

DORITT L. CARROLL, EXAMINING ATTORNEY

CLASS 10—(Continued).

SN 85-266,984. GENII, INC., MAPLEWOOD, MN. FILED 3-15-
2011.

ArConnect

THE MARK CONSISTS OF STANDARD CHARACTERS
WITHOUT CLAIM TO ANY PARTICULAR FONT, STYLE,
SIZE, OR COLOR.

FOR ELECTRICAL AND ARGON GAS CONNECTORS
FOR CONDUCTING ELECTRICITY AND ARGON GAS
FROM A GENERATOR TO AN ELECTROSURGICAL
PROBE, USED EXCLUSIVELY IN MEDICAL PROCE-
DURES (U.S. CLS. 26, 39 AND 44).

FRED CARL, EXAMINING ATTORNEY

SN 85-262,570. SEYED HAMIDREZA HASHEMI, BOCA
RATON, FL. FILED 3-9-2011.

Larger Box

THE MARK CONSISTS OF STANDARD CHARACTERS
WITHOUT CLAIM TO ANY PARTICULAR FONT, STYLE,
SIZE, OR COLOR.

FOR ADULT SEXUAL STIMULATION AIDS,
NAMELY, PENIS EXTENSION MEDICAL DEVISE FOR
PENILE ENLARGEMENT, PEYRONIE'S DISEASE, AND
PENILE CURVATURE TREATMENT (U.S. CLS. 26, 39
AND 44).

MAYUR VAGHANI, EXAMINING ATTORNEY

SN 85-269,741. FUDAKANG INDUSTRIAL LLC, PLAINS-
BORO, NJ. FILED 3-17-2011.

FDK

THE MARK CONSISTS OF STANDARD CHARACTERS
WITHOUT CLAIM TO ANY PARTICULAR FONT, STYLE,
SIZE, OR COLOR.

FOR MEDICAL METERS FOR MEDICAL PURPOSES,
NAMELY, THERMOMETER, BLOOD PRESSURE ME-
TER (U.S. CLS. 26, 39 AND 44).

FIRST USE 1-1-2011; IN COMMERCE 1-1-2011.

BRIAN PINO, EXAMINING ATTORNEY

SN 85-262,730. VARIAN MEDICAL SYSTEMS, INC., PALO
ALTO, CA. FILED 3-9-2011.

PAXPOWER

THE MARK CONSISTS OF STANDARD CHARACTERS
WITHOUT CLAIM TO ANY PARTICULAR FONT, STYLE,
SIZE, OR COLOR.

OWNER OF U.S. REG. NO. 2,646,113.
FOR X-RAY TUBES FOR MEDICAL PURPOSES (U.S.
CLS. 26, 39 AND 44).

HAI-LY LAM, EXAMINING ATTORNEY

SN 85-273,904. FAB NECESSITIES, LLC, FORT LEE, NJ.
FILED 3-22-2011.

nose secret

THE MARK CONSISTS OF STANDARD CHARACTERS
WITHOUT CLAIM TO ANY PARTICULAR FONT, STYLE,
SIZE, OR COLOR.

NO CLAIM IS MADE TO THE EXCLUSIVE RIGHT TO
USE "NOSE", APART FROM THE MARK AS SHOWN.

FOR SPLINTS FOR NOSE (U.S. CLS. 26, 39 AND 44).

FIRST USE 9-27-2007; IN COMMERCE 10-30-2008.

DAWN HAN, EXAMINING ATTORNEY

CLASS 10—(Continued).

SN 85-274,339. MIKKEN INTERNATIONAL, LLC, FARMINGTON HILLS, MI. FILED 3-23-2011.

GLOVOLOGY

THE MARK CONSISTS OF STANDARD CHARACTERS WITHOUT CLAIM TO ANY PARTICULAR FONT, STYLE, SIZE, OR COLOR.

OWNER OF U.S. REG. NOS. 3,785,315 AND 3,785,316. FOR CONDOMS (U.S. CLS. 26, 39 AND 44). AMY KERTGATE, EXAMINING ATTORNEY

SN 85-274,352. MIKKEN INTERNATIONAL, LLC, FARMINGTON HILLS, MI. FILED 3-23-2011.

GLOVOLOGY GIRL

THE MARK CONSISTS OF STANDARD CHARACTERS WITHOUT CLAIM TO ANY PARTICULAR FONT, STYLE, SIZE, OR COLOR.

OWNER OF U.S. REG. NOS. 3,785,315 AND 3,785,316. FOR CONDOMS (U.S. CLS. 26, 39 AND 44). AMY KERTGATE, EXAMINING ATTORNEY

SN 85-274,658. CURVEBEAM, LLC, WARRINGTON, PA. FILED 3-23-2011.

PEDCAT

THE MARK CONSISTS OF STANDARD CHARACTERS WITHOUT CLAIM TO ANY PARTICULAR FONT, STYLE, SIZE, OR COLOR.

FOR MEDICAL IMAGING DEVICES, NAMELY, COMPACT CONE BEAM COMPUTED TOMOGRAPHY DEVICES FOR 3-D IMAGING OF FEET IN BOTH LOAD BEARING AND NON-LOAD BEARING POSITIONS (U.S. CLS. 26, 39 AND 44).

MATTHEW MCDOWELL, EXAMINING ATTORNEY

CLASS 10—(Continued).

SN 85-274,665. CURVEBEAM, LLC, WARRINGTON, PA. FILED 3-23-2011.

PODCAT

THE MARK CONSISTS OF STANDARD CHARACTERS WITHOUT CLAIM TO ANY PARTICULAR FONT, STYLE, SIZE, OR COLOR.

FOR MEDICAL IMAGING DEVICES, NAMELY, COMPACT CONE BEAM COMPUTED TOMOGRAPHY DEVICES FOR 3-D IMAGING OF FEET IN BOTH LOAD BEARING AND NON-LOAD BEARING POSITIONS (U.S. CLS. 26, 39 AND 44).

MATTHEW MCDOWELL, EXAMINING ATTORNEY

SN 85-277,316. DR. D. EDWARD TARR, TULSA, OK. FILED 3-25-2011.

PROPHYEASE

THE MARK CONSISTS OF STANDARD CHARACTERS WITHOUT CLAIM TO ANY PARTICULAR FONT, STYLE, SIZE, OR COLOR.

FOR DENTAL INSTRUMENTS, NAMELY, COMBINATION DENTAL POLISHING CUP AND PRE-FILLED PASTE DISPENSING DEVICES (U.S. CLS. 26, 39 AND 44).

TAMARA FRAZIER, EXAMINING ATTORNEY

SN 85-279,161. BROCK, KIRSTEN, ALPHARETTA, GA. FILED 3-28-2011.



gym monkey

THE MARK CONSISTS OF A MONKEY CARTOON AND THE WORDS "MONKEY GYM".

FOR THERAPEUTIC HOT AND COLD COMPRESSION WRAPS (U.S. CLS. 26, 39 AND 44).

JACQUELINE A. LAVINE, EXAMINING ATTORNEY

CLASS 10—(Continued).

SN 85-286,032. NICHOLS THERAPY SYSTEMS, LLC, SABBETHA, KS. FILED 4-5-2011.

iTrac

THE MARK CONSISTS OF STANDARD CHARACTERS WITHOUT CLAIM TO ANY PARTICULAR FONT, STYLE, SIZE, OR COLOR.

FOR TRACTION APPARATUS FOR MEDICAL USE (U.S. CLS. 26, 39 AND 44).
FIRST USE 1-22-2007; IN COMMERCE 2-7-2008.
TOBY BULLOFF, EXAMINING ATTORNEY

SN 85-288,835. HOSPITECH RESPIRATION LTD., PETACH-TIKVA 49250, ISRAEL, FILED 4-7-2011.

ANAPNOGUARD

THE MARK CONSISTS OF STANDARD CHARACTERS WITHOUT CLAIM TO ANY PARTICULAR FONT, STYLE, SIZE, OR COLOR.

FOR RESPIRATORY GUARD SYSTEM COMPRISING PRIMARILY OF AN ELECTRONIC CONTROL UNIT, ENDOTRACHEAL TUBES, DISPOSABLE INTERCONNECTIONS AND FILTERING KITS CONNECTING THE TUBES TO THE CONTROL UNIT, FOR PREVENTING COMPLICATIONS RELATED TO PROLONGED MECHANICAL VENTILATION, INCLUDING AIR LEAKAGE FROM THE LUNGS, ASPIRATION OF SUBGLOTTIC SECRETIONS INTO THE LUNGS AND TRACHEA MECHANICAL COMPLICATIONS (U.S. CLS. 26, 39 AND 44).

ANNE MADDEN, EXAMINING ATTORNEY

SN 85-288,859. KENTRON HEALTH CARE, INC, SPRINGFIELD, TN. FILED 4-7-2011.

KENOREX

THE MARK CONSISTS OF STANDARD CHARACTERS WITHOUT CLAIM TO ANY PARTICULAR FONT, STYLE, SIZE, OR COLOR.

FOR MEDICAL INTUBATION EQUIPMENT; ENDOTRACHEAL TUBES; RESUSCITATORS; MASKS FOR USE BY MEDICAL PERSONNEL; MEDICAL INSTRUMENTS TO MEASURE BLOOD PRESSURE; CATHETERS; ELASTIC BANDAGES (U.S. CLS. 26, 39 AND 44).
FIRST USE 1-1-2006; IN COMMERCE 1-1-2006.

KRISTINA MORRIS, EXAMINING ATTORNEY

CLASS 10—(Continued).

SN 85-289,749. VALLOPPILLIL, SANTHOSH, HOUSTON, TX. FILED 4-8-2011.

OSTEOCENE

THE MARK CONSISTS OF STANDARD CHARACTERS WITHOUT CLAIM TO ANY PARTICULAR FONT, STYLE, SIZE, OR COLOR.

FOR MEDICAL INSTRUMENTS FOR CONTROLLED DRUG DELIVERY AND BONE RECONSTRUCTION (U.S. CLS. 26, 39 AND 44).
GENE MACIOL, EXAMINING ATTORNEY

SN 85-290,805. NEILMED PRODUCTS, INC., SANTA ROSA, CA. FILED 4-8-2011.

SINUGATOR

THE MARK CONSISTS OF STANDARD CHARACTERS WITHOUT CLAIM TO ANY PARTICULAR FONT, STYLE, SIZE, OR COLOR.

OWNER OF U.S. REG. NOS. 3,410,449 AND 3,674,550.
FOR NASAL IRRIGATORS FOR MEDICAL OR PERSONAL USE (U.S. CLS. 26, 39 AND 44).
ALYSSA STEEL, EXAMINING ATTORNEY

SN 85-292,642. STERIGEAR, LLC, PROVO, UT. FILED 4-12-2011.

FIG LEAF

THE MARK CONSISTS OF STANDARD CHARACTERS WITHOUT CLAIM TO ANY PARTICULAR FONT, STYLE, SIZE, OR COLOR.

FOR BAG FOR COLLECTION OF BODILY FLUIDS AND WASTE (U.S. CLS. 26, 39 AND 44).

SHAUNIA CARLYLE, EXAMINING ATTORNEY

CLASS 10—(Continued).

SN 85-293,005. TRYTON MEDICAL, INC., DURHAM, NC.
FILED 4-12-2011.

Tri-ZONE

THE MARK CONSISTS OF STANDARD CHARACTERS
WITHOUT CLAIM TO ANY PARTICULAR FONT, STYLE,
SIZE, OR COLOR.

FOR MEDICAL STENTS (U.S. CLS. 26, 39 AND 44).
DAVID I, EXAMINING ATTORNEY

SN 85-293,414. BRENDemuEHL, JAMES, AIKEN, SC. FILED
4-12-2011.

EQUI-RING

THE MARK CONSISTS OF STANDARD CHARACTERS
WITHOUT CLAIM TO ANY PARTICULAR FONT, STYLE,
SIZE, OR COLOR.

FOR INTRA-VAGINAL DRUG DELIVERY SYSTEMS
FOR HORSES (U.S. CLS. 26, 39 AND 44).
PATRICIA EVANKO, EXAMINING ATTORNEY

SN 85-294,100. ORTHOPEDIATRICS CORP., WARSAW, IN.
FILED 4-13-2011.

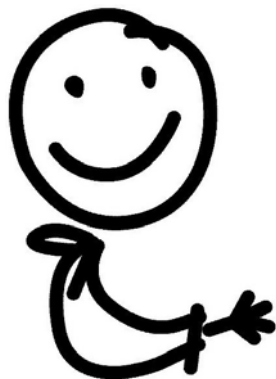

THE MARK CONSISTS OF A CARTOON DRAWING
THAT INCLUDES A SLING, A SMILING FACE ABOVE
THE SLING, AND A WRIST AND HAND EXTENDING
FROM THE DISTAL END OF THE SLING.

FOR SURGICAL AND MEDICAL APPARATUS AND
INSTRUMENTS FOR USE IN ORTHOPEDIC SURGERY
(U.S. CLS. 26, 39 AND 44).

FIRST USE 1-1-2009; IN COMMERCE 1-1-2009.
LIEF MARTIN, EXAMINING ATTORNEY

CLASS 10—(Continued).

SN 85-294,315. DENTSPLY INTERNATIONAL INC., YORK,
PA. FILED 4-13-2011.

NUPRO FREEDOM

THE MARK CONSISTS OF STANDARD CHARACTERS
WITHOUT CLAIM TO ANY PARTICULAR FONT, STYLE,
SIZE, OR COLOR.

OWNER OF U.S. REG. NOS. 962,204, 3,522,236 AND
OTHERS.

FOR DENTAL HANDPIECES (U.S. CLS. 26, 39 AND
44).

HEATHER THOMPSON, EXAMINING ATTORNEY

SN 85-294,736. FLATS BELLY WRAPS LLC, DBA WINK,
SUITE B, CA. FILED S.R. 4-13-2011; AM. P.R. 7-18-2011.

Wink your little secret

THE MARK CONSISTS OF STANDARD CHARACTERS
WITHOUT CLAIM TO ANY PARTICULAR FONT, STYLE,
SIZE, OR COLOR.

FOR UNDERGARMENTS AND GIRDLES PROVIDING
COMPRESSION USED FOR POST-PREGNANCY AB-
DOMINAL SUPPORT AND COMPRESSION (U.S. CLS.
26, 39 AND 44).

FIRST USE 6-5-2009; IN COMMERCE 11-15-2009.
MICHAEL ENGEL, EXAMINING ATTORNEY

SN 85-297,710. DENTSPLY INTERNATIONAL INC., YORK,
PA. FILED 4-18-2011.

PHOENIX

THE MARK CONSISTS OF STANDARD CHARACTERS
WITHOUT CLAIM TO ANY PARTICULAR FONT, STYLE,
SIZE, OR COLOR.

OWNER OF U.S. REG. NO. 1,692,744.

FOR ORTHODONTIC APPLIANCES (U.S. CLS. 26, 39
AND 44).

HEATHER THOMPSON, EXAMINING ATTORNEY

CLASS 10—(Continued).

SN 85-308,110. INTERVENTIONAL THERAPIES, LLC, WESTPORT, CT. FILED 4-29-2011.

CLASS 10—(Continued).

SN 85-316,684. KIMBERLY-CLARK WORLDWIDE, INC., NEENAH, WI. FILED 5-10-2011.

DUAL-CLOSE

SMART-FOLD

THE MARK CONSISTS OF STANDARD CHARACTERS WITHOUT CLAIM TO ANY PARTICULAR FONT, STYLE, SIZE, OR COLOR.

FOR SURGICAL INSTRUMENTS, NAMELY, SUTURING DEVICES AND SUTURE CRIMPING DEVICES, ESPECIALLY FOR LARGE CLOSURES (U.S. CLS. 26, 39 AND 44).

WANDA KAY PRICE, EXAMINING ATTORNEY

THE MARK CONSISTS OF STANDARD CHARACTERS WITHOUT CLAIM TO ANY PARTICULAR FONT, STYLE, SIZE, OR COLOR.

FOR NONWOVEN WRAPPER USED TO STERILIZE SURGICAL INSTRUMENTS AND SUPPLIES (U.S. CLS. 26, 39 AND 44).

JOHN HWANG, EXAMINING ATTORNEY

SN 85-308,888. EDWARDS LIFESCIENCES CORPORATION, IRVINE, CA. FILED 4-29-2011.

SN 85-323,531. DENTSPLY INTERNATIONAL INC., YORK, PA. FILED 5-18-2011.

INTRACLUDGE

MAP

THE MARK CONSISTS OF STANDARD CHARACTERS WITHOUT CLAIM TO ANY PARTICULAR FONT, STYLE, SIZE, OR COLOR.

FOR MEDICAL DEVICES, NAMELY CATHETERS FOR CARDIOVASCULAR TREATMENT (U.S. CLS. 26, 39 AND 44).

TEJBIR SINGH, EXAMINING ATTORNEY

THE MARK CONSISTS OF STANDARD CHARACTERS WITHOUT CLAIM TO ANY PARTICULAR FONT, STYLE, SIZE, OR COLOR.

FOR DENTAL INSTRUMENTS, NAMELY, A DELIVERY SYSTEM FOR DENTAL MATERIALS CONSISTING OF A HOLLOW TUBE SYRINGE AND PLACEMENT CANNULAS (U.S. CLS. 26, 39 AND 44).

FIRST USE 7-8-2003; IN COMMERCE 7-8-2003.

HEATHER THOMPSON, EXAMINING ATTORNEY

SN 85-313,456. SONOSITE, INC., BOTHELL, WA. FILED 5-5-2011.

SN 85-324,946. DENTSPLY INTERNATIONAL INC., YORK, PA. FILED 5-19-2011.

OCTANE

PROMARK

THE MARK CONSISTS OF STANDARD CHARACTERS WITHOUT CLAIM TO ANY PARTICULAR FONT, STYLE, SIZE, OR COLOR.

FOR MEDICAL ULTRASOUND APPARATUS; ULTRASOUND DIAGNOSTIC APPARATUS (U.S. CLS. 26, 39 AND 44).

KEVIN CORWIN, EXAMINING ATTORNEY

THE MARK CONSISTS OF STANDARD CHARACTERS WITHOUT CLAIM TO ANY PARTICULAR FONT, STYLE, SIZE, OR COLOR.

FOR ENDODONTIC APPARATUS (U.S. CLS. 26, 39 AND 44).

HEATHER THOMPSON, EXAMINING ATTORNEY

CLASS 11—ENVIRONMENTAL CONTROL APPARATUS

SN 76-707,422. SHARP KABUSHIKI KAISHA, TA SHARP CORPORATION, OSAKA 545-8522, JAPAN, FILED 4-27-2011.

SHARP

THE MARK CONSISTS OF STANDARD CHARACTERS WITHOUT CLAIM TO ANY PARTICULAR FONT, STYLE, SIZE, OR COLOR.

OWNER OF U.S. REG. NOS. 1,120,410, 1,526,673 AND 3,781,458.

FOR LIGHTING APPARATUS, NAMELY, LIGHTING INSTALLATIONS USING LIGHT EMITTING DIODES AS A LIGHT SOURCE; LIGHTING APPARATUS, NAMELY, LIGHT BULBS; LIGHTING INSTALLATIONS USING NON-LIGHT EMITTING DIODES AS A LIGHT SOURCE (U.S. CLS. 13, 21, 23, 31 AND 34).

FIRST USE 8-30-2010; IN COMMERCE 8-30-2010.
MARK SPARACINO, EXAMINING ATTORNEY

SN 77-328,847. GESTION ULTRA INTERNATIONALE INC., QUEBEC, CANADA, FILED 11-14-2007.

SENSORIUM

THE MARK CONSISTS OF STANDARD CHARACTERS WITHOUT CLAIM TO ANY PARTICULAR FONT, STYLE, SIZE, OR COLOR.

PRIORITY CLAIMED UNDER SEC. 44(D) ON CANADA APPLICATION NO. 1371298, FILED 11-8-2007, REG. NO. TMA796988, DATED 5-9-2011, EXPIRES 5-9-2026.

FOR THERAPEUTIC BATHTUBS AND SHOWERS (U.S. CLS. 13, 21, 23, 31 AND 34).

ROBIN MITTLER, EXAMINING ATTORNEY

SN 77-328,848. GESTION ULTRA INTERNATIONALE INC., QUEBEC, CANADA, FILED 11-14-2007.

ESSENSORIUM

THE MARK CONSISTS OF STANDARD CHARACTERS WITHOUT CLAIM TO ANY PARTICULAR FONT, STYLE, SIZE, OR COLOR.

PRIORITY CLAIMED UNDER SEC. 44(D) ON CANADA APPLICATION NO. 1371296, FILED 11-8-2007, REG. NO. TMA796,987, DATED 5-9-2011, EXPIRES 5-9-2026.

FOR THERAPEUTIC BATHTUBS AND SHOWERS (U.S. CLS. 13, 21, 23, 31 AND 34).

ROBIN MITTLER, EXAMINING ATTORNEY

CLASS 11—(Continued).

SN 77-406,381. TATUM MANUFACTURING, TAMPA, FL. FILED 2-26-2008.

LIVING WATER

THE MARK CONSISTS OF STANDARD CHARACTERS WITHOUT CLAIM TO ANY PARTICULAR FONT, STYLE, SIZE, OR COLOR.

FOR HOT TUBS, PORTABLE SPAS IN THE NATURE OF HEATED POOLS, PARTS AND ACCESSORIES FOR HOT TUBS AND PORTABLE SPAS, NAMELY, FITTED SPA COVERS AND HOT TUB JETS (U.S. CLS. 13, 21, 23, 31 AND 34).

KAPIL BHANOT, EXAMINING ATTORNEY

SN 77-830,011. FLOW CONTROL INDUSTRIES, INC., WOODINVILLE, WA. FILED 9-18-2009.



OWNER OF U.S. REG. NOS. 2,768,899, 3,327,591 AND OTHERS.

NO CLAIM IS MADE TO THE EXCLUSIVE RIGHT TO USE "T VALVE", APART FROM THE MARK AS SHOWN.

THE MARK CONSISTS OF A DESIGN COMPRISED OF THREE TRIANGLES, TWO OF WHICH ARE CONNECTED POINT-TO-POINT WITH A PARALLEL LINE EXITING THE SIDES OF THESE TRIANGLES, WITH THE THIRD POSITIONED ABOVE AND CONNECTED BY A VERTICAL LINE AND WITH THE WORDING "DELTA" TO THE LEFT OF THE TRIANGLE, THE LETTER "T" WITHIN THE TRIANGLE, AND THE WORD "VALVE" TO THE RIGHT OF THE TRIANGLE.

FOR MANUALLY-OPERATED METAL FLUID VALVES, ALL FOR USE IN HEATING, VENTILATION, AND AIR-CONDITIONING (HVAC) SYSTEMS (U.S. CLS. 13, 21, 23, 31 AND 34).

DAVID COLLIER, EXAMINING ATTORNEY

SN 77-830,155. FLOW CONTROL INDUSTRIES, INC., WOODINVILLE, WA. FILED 9-18-2009.

DELTA "T" VALVE

THE MARK CONSISTS OF STANDARD CHARACTERS WITHOUT CLAIM TO ANY PARTICULAR FONT, STYLE, SIZE, OR COLOR.

OWNER OF U.S. REG. NOS. 2,768,898, 2,983,047 AND OTHERS.

FOR MANUALLY-OPERATED METAL FLUID VALVES, ALL FOR USE IN HEATING, VENTILATION, AND AIR-CONDITIONING (HVAC) SYSTEMS (U.S. CLS. 13, 21, 23, 31 AND 34).

FIRST USE 8-24-2009; IN COMMERCE 8-24-2009.

DAVID COLLIER, EXAMINING ATTORNEY

CLASS 11—(Continued).

SN 77-929,716. HEATCRAFT REFRIGERATION PRODUCTS LLC, STONE MOUNTAIN, GA. FILED 2-6-2010.



THE MARK CONSISTS OF WAVY LINES BETWEEN THE WORDS "CLIMATE CONTROL".

SEC. 2(F).

FOR INDOOR AIR COOLING UNITS, APPARATUS AND VENTILATORS ALL FOR USE IN COOLING, REFRIGERATING AND FREEZING FOR COMMERCIAL AND INDUSTRIAL REFRIGERATION APPLICATIONS; OUTDOOR AIR COOLING UNITS AND APPARATUS FOR CONDENSING COMPRESSED VAPOR REFRIGERANT FOR COMMERCIAL AND INDUSTRIAL REFRIGERATION APPLICATIONS (U.S. CLS. 13, 21, 23, 31 AND 34).

FIRST USE 2-0-2006; IN COMMERCE 3-10-2006.

WARREN L. OLANDRIA, EXAMINING ATTORNEY

SN 77-944,444. SWEP INTERNATIONAL AB, LANDSKRONA, SWEDEN, FILED 2-25-2010.



PRIORITY CLAIMED UNDER SEC. 44(D) ON SWEDEN APPLICATION NO. 2009/06427, FILED 9-1-2009.

THE COLOR(S) GRAY AND RED IS/ARE CLAIMED AS A FEATURE OF THE MARK.

THE MARK CONSISTS OF THE TERM "ASYMMETRIC" HAVING CAPITAL LETTERS "A" AND "M" WITH THE MARK IN A GRAY COLOR WITH THE EXCEPTION THAT A STYLIZED PORTION OF THE LETTER "X" IS IN A RED COLOR.

FOR TAPS FOR DUCTS; REGULATING ACCESSORIES FOR WATER APPARATUS; PIPES AND TUBES FORMING PARTS OF HOT WATER SYSTEMS; WATER HEATERS; AIR-CONDITIONING VENTILATION INSTALLATIONS AND APPARATUS; RADIATORS FOR HEATING, HEATING INSTALLATIONS, BOILERS, HEAT EXCHANGERS AND PARTS AND ACCESSORIES THEREFOR (U.S. CLS. 13, 21, 23, 31 AND 34).

FIRST USE 8-31-2010; IN COMMERCE 8-31-2010.

NAKWAMA ANKRAH, EXAMINING ATTORNEY

CLASS 11—(Continued).

SN 77-957,330. MAAX BATH INC., LACHINE, QUEBEC, CANADA, FILED 3-12-2010.



PRIORITY CLAIMED UNDER SEC. 44(D) ON CANADA APPLICATION NO. 1472876, FILED 3-12-2010, REG. NO. 797206, DATED 5-11-2011, EXPIRES 5-11-2026.

THE MARK CONSISTS OF THE WORD "PURFECTKURV" WITH A LINE ON TOP OF BOTH APPEARANCES OF THE LOWER-CASE LETTER "U" IN THE MARK.

FOR SHOWER DOORS (U.S. CLS. 13, 21, 23, 31 AND 34).

MICHAEL ENGEL, EXAMINING ATTORNEY

SN 77-963,872. PHOSEON TECHNOLOGY, INC., HILLSBORO, OR. FILED 3-19-2010.



THE MARK CONSISTS OF STANDARD CHARACTERS WITHOUT CLAIM TO ANY PARTICULAR FONT, STYLE, SIZE, OR COLOR.

OWNER OF U.S. REG. NOS. 2,890,265 AND 2,940,674.

FOR LIGHT CURING SYSTEMS FOR INDUSTRIAL APPLICATIONS; UV CURING SYSTEMS FOR COMMERCIAL APPLICATIONS, NAMELY, FOR CURING INKS, COATINGS, ADHESIVES, AND A VARIETY OF OTHER MATERIALS (U.S. CLS. 13, 21, 23, 31 AND 34).

KIM MONINGHOFF, EXAMINING ATTORNEY

SN 79-088,363. METAL SPOT S.P.A., ITALY, FILED 9-16-2010.



PRIORITY DATE OF 8-3-2010 IS CLAIMED.

OWNER OF INTERNATIONAL REGISTRATION 1053968 DATED 9-16-2010, EXPIRES 9-16-2020.

OWNER OF U.S. REG. NO. 3,135,991.

THE MARK CONSISTS OF THE WORDING "METALSPOT" IN STYLIZED SCRIPT.

FOR APPARATUS FOR LIGHTING, NAMELY, CHANDELIERS, CEILING LAMPS, AND ELECTRIC LAMPS, AND THEIR FITTINGS (U.S. CLS. 13, 21, 23, 31 AND 34).

JESSICA FATHY, EXAMINING ATTORNEY

CLASS 11—(Continued).

SN 79-096,472. RATIONAL AG, FED REP GERMANY, FILED 2-28-2011.



PRIORITY DATE OF 11-9-2010 IS CLAIMED.
OWNER OF INTERNATIONAL REGISTRATION 1074652 DATED 2-28-2011, EXPIRES 2-28-2021.

THE MARK CONSIST OF THE STYLIZED WORDING "WHITEFFICIENCY" WITH A SQUARE AROUND THE FIRST "E" AND CHEF'S HAT ABOVE THE WORDING WITH A CURVED LINE GOING THROUGH THE HAT ALONG THE LENGTH OF THE WORDING.

FOR COOKING AND STEAM GENERATING APPARATUS FOR THE TREATMENT AND PREPARATION OF FOOD IN COMMERCIAL KITCHENS, NAMELY, ELECTRIC FOOD COOKERS, ELECTRIC FOOD STEAMERS, AND COOKING OVENS, ALL FOR COMMERCIAL USE AND SOLD AS A UNIT; GAS FOOD COOKERS, GAS FOOD STEAMERS AND COOKING OVENS, ALL FOR COMMERCIAL USE AND SOLD AS A UNIT; AND STRUCTURAL PARTS AND ACCESSORIES THEREFOR (U.S. CLS. 13, 21, 23, 31 AND 34).

NICHOLAS COLEMAN, EXAMINING ATTORNEY

SN 79-099,140. ZHONGSHAN GUZHEN MODERN LIGHTING ELECTRON FACTORY, GUANGDONG PROVINCE, CHINA, FILED 4-11-2011.



OWNER OF INTERNATIONAL REGISTRATION 1082040 DATED 4-11-2011, EXPIRES 1-15-2022.

THE MARK CONSISTS OF STYLIZED WORD "BMC".
FOR LAMPS; FLUORESCENT LAMP TUBES; LIGHTS FOR VEHICLES; SOLDERING LAMPS; ELECTRIC COOKING OVENS; REFRIGERATORS; ELECTRIC FANS; HEATING INSTALLATIONS; DISH DISINFECTANT APPARATUS FOR INDUSTRIAL PURPOSES; ELECTRIC RADIATORS (U.S. CLS. 13, 21, 23, 31 AND 34).

BERNICE MIDDLETON, EXAMINING ATTORNEY

SN 85-049,717. NORSEMEN ENTERTAINMENT LLC, PLAYA VISTA, CA. FILED 5-27-2010.

KNIGHT LIGHTS

THE MARK CONSISTS OF STANDARD CHARACTERS WITHOUT CLAIM TO ANY PARTICULAR FONT, STYLE, SIZE, OR COLOR.

FOR ELECTRICAL LAMPS THAT PLUG DIRECTLY INTO WALL SOCKETS (U.S. CLS. 13, 21, 23, 31 AND 34).
JOHN WILKE, EXAMINING ATTORNEY

CLASS 11—(Continued).

SN 85-102,163. INNOVATIVE LIGHTING INC., ROLAND, IA. FILED 8-6-2010.

P.O.P. TECHNOLOGY

THE MARK CONSISTS OF STANDARD CHARACTERS WITHOUT CLAIM TO ANY PARTICULAR FONT, STYLE, SIZE, OR COLOR.

NO CLAIM IS MADE TO THE EXCLUSIVE RIGHT TO USE "TECHNOLOGY", APART FROM THE MARK AS SHOWN.

FOR OPTICAL LENS COVERS THAT IMPROVES LIGHT OUTPUT AND UNIFORMITY, AND PROTECTS THE LED SOLD AS A FEATURE OF AN LED LIGHTING SYSTEM (U.S. CLS. 13, 21, 23, 31 AND 34).

FIRST USE 3-20-2010; IN COMMERCE 4-15-2010.

ELIZABETH HUGHITT, EXAMINING ATTORNEY

SN 85-118,385. FILTER PURE SYSTEMS, INC., TAMPA, FL. FILED 8-30-2010.

FILTER PURE SYSTEMS

THE MARK CONSISTS OF STANDARD CHARACTERS WITHOUT CLAIM TO ANY PARTICULAR FONT, STYLE, SIZE, OR COLOR.

NO CLAIM IS MADE TO THE EXCLUSIVE RIGHT TO USE "FILTER" AND "SYSTEMS", APART FROM THE MARK AS SHOWN.

SEC. 2(F).
FOR WATER FILTERING UNITS FOR COMMERCIAL AND RESIDENTIAL USE (U.S. CLS. 13, 21, 23, 31 AND 34).

FIRST USE 12-1-1981; IN COMMERCE 12-1-1981.

VIVIAN MICZNIK FIRST, EXAMINING ATTORNEY

SN 85-138,863. WCM INDUSTRIES, INC., COLORADO SPRINGS, CO. FILED 9-27-2010.

UNIVERSAL NUFIT

THE MARK CONSISTS OF STANDARD CHARACTERS WITHOUT CLAIM TO ANY PARTICULAR FONT, STYLE, SIZE, OR COLOR.

NO CLAIM IS MADE TO THE EXCLUSIVE RIGHT TO USE "UNIVERSAL", APART FROM THE MARK AS SHOWN.

FOR PLUMBING FITTINGS, NAMELY, DRAINS; TUB PARTS, NAMELY, TUB OVERFLOWS; TUB PARTS, NAMELY, TUB WASTES (U.S. CLS. 13, 21, 23, 31 AND 34).

RON FAIRBANKS, EXAMINING ATTORNEY

CLASS 11—(Continued).

SN 85-175,743. CARRIER CORPORATION, FARMINGTON, CT. FILED 11-12-2010.

NaturaLINE

THE MARK CONSISTS OF STANDARD CHARACTERS WITHOUT CLAIM TO ANY PARTICULAR FONT, STYLE, SIZE, OR COLOR.

FOR REFRIGERATION UNITS FOR SHIPPING CONTAINERS; NATURAL REFRIGERANT REFRIGERATION UNITS FOR SHIPPING CONTAINERS; NATURAL REFRIGERANT (CO2) REFRIGERATION UNITS FOR SHIPPING CONTAINERS (U.S. CLS. 13, 21, 23, 31 AND 34).

JORDAN BAKER, EXAMINING ATTORNEY

SN 85-188,287. REDNECK SCIENTIFIC INC., CLAYTON, NC. FILED 12-1-2010.

Redneck Convection Oven

THE MARK CONSISTS OF STANDARD CHARACTERS WITHOUT CLAIM TO ANY PARTICULAR FONT, STYLE, SIZE, OR COLOR.

NO CLAIM IS MADE TO THE EXCLUSIVE RIGHT TO USE "CONVECTION OVEN", APART FROM THE MARK AS SHOWN.

FOR BARBECUE SMOKERS (U.S. CLS. 13, 21, 23, 31 AND 34).

FIRST USE 9-1-2010; IN COMMERCE 9-1-2010.
TARA PATE, EXAMINING ATTORNEY

SN 85-196,329. DAFUN DESIGN CONSULTANT CO., LTD., KAOHSIUNG CITY, TAIWAN, FILED 12-13-2010.



THE MARK CONSISTS OF A STYLIZED WORD "TRUVII".

FOR CAMPING LAMPS, FLASHLIGHTS, LAMP SHADES, LAMP CASINGS, LAMP BASES; LIGHTS FOR VEHICLES; LAMPS FOR BICYCLES, ELECTRIC LAMPS, DESK LAMPS, LIGHT BULBS; SOLAR LIGHT FIXTURES, NAMELY, INDOOR AND OUTDOOR SOLAR POWERED LIGHTING UNITS AND FIXTURES; ELECTRIC LIGHT FOR CHRISTMAS TREES; HYDRANTS; WATER FILTERING APPARATUS (U.S. CLS. 13, 21, 23, 31 AND 34).

FIRST USE 8-2-2010; IN COMMERCE 10-20-2010.
BARBARA GAYNOR, EXAMINING ATTORNEY

CLASS 11—(Continued).

SN 85-245,127. PACKAGING TECHNOLOGY GROUP, INC., FALL RIVER, MA. FILED 2-17-2011.

COOLBRICK

THE MARK CONSISTS OF STANDARD CHARACTERS WITHOUT CLAIM TO ANY PARTICULAR FONT, STYLE, SIZE, OR COLOR.

FOR COOLING PACKS, NAMELY, ABSORBENT FOAM BLOCKS SATURATED WITH AN AQUEOUS SOLUTION, PACKAGED IN A PLASTIC WRAPPING AND FROZEN, FOR MAINTAINING ITEMS COLD IN SHIPPING CONTAINERS (U.S. CLS. 13, 21, 23, 31 AND 34).

FIRST USE 1-27-2006; IN COMMERCE 1-27-2006.
WILLIAM P. SHANAHAN, EXAMINING ATTORNEY

SN 85-256,212. SEYCHELLE ENVIRONMENTAL TECHNOLOGIES, INC., SAN JUAN CAPISTRANO, CA. FILED 3-2-2011.

Aq-RO-matic

THE MARK CONSISTS OF STANDARD CHARACTERS WITHOUT CLAIM TO ANY PARTICULAR FONT, STYLE, SIZE, OR COLOR.

FOR WATER TREATMENT EQUIPMENT, NAMELY, REVERSE OSMOSIS WATER FILTRATION UNITS FOR PURIFYING DRINKING WATER (U.S. CLS. 13, 21, 23, 31 AND 34).

DAWN HAN, EXAMINING ATTORNEY

SN 85-265,808. KOHLER CO., KOHLER, WI. FILED 3-14-2011.

KENNEBEC

THE MARK CONSISTS OF STANDARD CHARACTERS WITHOUT CLAIM TO ANY PARTICULAR FONT, STYLE, SIZE, OR COLOR.

FOR TOILETS (U.S. CLS. 13, 21, 23, 31 AND 34).
STEVEN JACKSON, EXAMINING ATTORNEY

CLASS 11—(Continued).

SN 85-273,729. KOHLER CO., KOHLER, WI. FILED 3-22-2011.

RIVERBY

THE MARK CONSISTS OF STANDARD CHARACTERS WITHOUT CLAIM TO ANY PARTICULAR FONT, STYLE, SIZE, OR COLOR.

FOR SINKS (U.S. CLS. 13, 21, 23, 31 AND 34).
STEVEN JACKSON, EXAMINING ATTORNEY

SN 85-273,748. KOHLER CO., KOHLER, WI. FILED 3-22-2011.

WHITEHAVEN

THE MARK CONSISTS OF STANDARD CHARACTERS WITHOUT CLAIM TO ANY PARTICULAR FONT, STYLE, SIZE, OR COLOR.

FOR SINKS (U.S. CLS. 13, 21, 23, 31 AND 34).
STEVEN JACKSON, EXAMINING ATTORNEY

SN 85-275,240. WU HAIHONG, PUNING, GUANGDONG, CHINA, FILED 3-24-2011.

INSE

THE MARK CONSISTS OF LATIN CHARACTERS "INSE" IN UPPER CASE.

FOR AIR CONDITIONERS; BAKING OVENS; ELECTRIC COFFEE MAKERS; ELECTRIC COOKING STOVES; ELECTRIC GRILLS; ELECTRIC RICE COOKERS; ELECTRIC SPACE HEATERS; ELECTRIC TOASTERS; ELECTROMAGNETIC INDUCTION COOKERS; GAS COOKERS; GAS GRILLS; GAS STOVES; HEATING BOILERS; INCANDESCENT LAMPS AND THEIR FITTINGS; LAVATORY BOWLS; MICROWAVE OVENS FOR HOUSEHOLD PURPOSES; RANGE HOODS; SHOWER ENCLOSURES; WATER CLOSETS; WATER HEATERS (U.S. CLS. 13, 21, 23, 31 AND 34).

CHRISTINE COOPER, EXAMINING ATTORNEY

CLASS 11—(Continued).

SN 85-276,067. XTREME POWER INC., KYLE, TX. FILED 3-24-2011.

XTREME POWER

THE MARK CONSISTS OF STANDARD CHARACTERS WITHOUT CLAIM TO ANY PARTICULAR FONT, STYLE, SIZE, OR COLOR.

NO CLAIM IS MADE TO THE EXCLUSIVE RIGHT TO USE "POWER", APART FROM THE MARK AS SHOWN.

FOR ENERGY STORAGE PLANTS (U.S. CLS. 13, 21, 23, 31 AND 34).

JAMES LOVELACE, EXAMINING ATTORNEY

SN 85-276,153. FANGIO ENTERPRISES INC., TA FANGIO LIGHTING, OLYPHANT, PA. FILED 3-24-2011.

M.R. LAMP & SHADE

THE MARK CONSISTS OF STANDARD CHARACTERS WITHOUT CLAIM TO ANY PARTICULAR FONT, STYLE, SIZE, OR COLOR.

NO CLAIM IS MADE TO THE EXCLUSIVE RIGHT TO USE "LAMP & SHADE", APART FROM THE MARK AS SHOWN.

FOR LAMP SHADES; LAMPS (U.S. CLS. 13, 21, 23, 31 AND 34).

APRIL HESIK, EXAMINING ATTORNEY

SN 85-276,218. UNDERWATER KINETICS, LP, POWAY, CA. FILED 3-24-2011.

GATORLITE

THE MARK CONSISTS OF STANDARD CHARACTERS WITHOUT CLAIM TO ANY PARTICULAR FONT, STYLE, SIZE, OR COLOR.

FOR DIVING LIGHTS; FLASHLIGHTS; LED UNDERWATER LIGHTS (U.S. CLS. 13, 21, 23, 31 AND 34).

FIRST USE 3-23-2011; IN COMMERCE 3-23-2011.

NICHOLAS ALTREE, EXAMINING ATTORNEY

CLASS 11—(Continued).

SN 85-277,101. TURBO POWER, INC., FLUSHING, NY.
FILED 3-25-2011.

SILENCER

THE MARK CONSISTS OF STANDARD CHARACTERS WITHOUT CLAIM TO ANY PARTICULAR FONT, STYLE, SIZE, OR COLOR.

FOR ELECTRIC HAIR STYLING APPLIANCES, NAMELY, HAND-HELD ELECTRIC HAIR DRYERS AND STYLING ATTACHMENTS SOLD AS INTEGRAL COMPONENTS THEREOF (U.S. CLS. 13, 21, 23, 31 AND 34).

NORA BUCHANAN WILL, EXAMINING ATTORNEY

CLASS 11—(Continued).

SN 85-279,236. UNDERWATER KINETICS, LP, POWAY, CA.
FILED 3-28-2011.

HYDRALUM

THE MARK CONSISTS OF STANDARD CHARACTERS WITHOUT CLAIM TO ANY PARTICULAR FONT, STYLE, SIZE, OR COLOR.

FOR DIVING LIGHTS; FLASHLIGHTS; LED UNDERWATER LIGHTS (U.S. CLS. 13, 21, 23, 31 AND 34).

NICHOLAS ALTREE, EXAMINING ATTORNEY

SN 85-277,392. BLUEAIR AB, STOCKHOLM, SWEDEN,
FILED 3-25-2011.

GO FILTER

THE MARK CONSISTS OF STANDARD CHARACTERS WITHOUT CLAIM TO ANY PARTICULAR FONT, STYLE, SIZE, OR COLOR.

NO CLAIM IS MADE TO THE EXCLUSIVE RIGHT TO USE "FILTER", APART FROM THE MARK AS SHOWN.

FOR AIR FILTERING INSTALLATIONS; AIR FILTERS FOR DOMESTIC USE (U.S. CLS. 13, 21, 23, 31 AND 34).

CHERYL CLAYTON, EXAMINING ATTORNEY

SN 85-282,718. FANGIO ENTERPRISES INC., TA FANGIO LIGHTING, OLYPHANT, PA. FILED 3-31-2011.

M.R. HIGH DEFINITION LAMPS AND SHADES

THE MARK CONSISTS OF STANDARD CHARACTERS WITHOUT CLAIM TO ANY PARTICULAR FONT, STYLE, SIZE, OR COLOR.

NO CLAIM IS MADE TO THE EXCLUSIVE RIGHT TO USE "HIGH DEFINITION LAMPS AND SHADES", APART FROM THE MARK AS SHOWN.

FOR LAMP SHADES; LAMPS (U.S. CLS. 13, 21, 23, 31 AND 34).

APRIL HESIK, EXAMINING ATTORNEY

SN 85-279,085. EDWARDS, WILLIAM T., SAINT GEORGE, UT. AND EDWARDS, JUDY M., SAINT GEORGE, UT. AND EDWARDS, ROBERT, SAINT GEORGE, UT. AND EDWARDS, SAMUEL H., SAINT GEORGE, UT. FILED 3-28-2011.

The Squatty Potty

THE MARK CONSISTS OF STANDARD CHARACTERS WITHOUT CLAIM TO ANY PARTICULAR FONT, STYLE, SIZE, OR COLOR.

FOR SMALL STOOLS DESIGNED TO FIT AROUND A TOILET TO AID IN THE ELIMINATION PROCESS, BY ALLOWING THE USER TO BE IN A SQUATTING POSITION OVER HIS TOILET FOR THE PURPOSE OF HELPING TO PREVENT HEMORRHOIDS AND CONSTIPATION AND OTHER COLON ISSUES (U.S. CLS. 13, 21, 23, 31 AND 34).

JAMES LOVELACE, EXAMINING ATTORNEY

SN 85-288,689. NISUS CORPORATION, ROCKFORD, TN.
FILED 4-7-2011.

MEGA DRY

THE MARK CONSISTS OF STANDARD CHARACTERS WITHOUT CLAIM TO ANY PARTICULAR FONT, STYLE, SIZE, OR COLOR.

NO CLAIM IS MADE TO THE EXCLUSIVE RIGHT TO USE "DRY", APART FROM THE MARK AS SHOWN.

FOR DEHUMIDIFIERS (U.S. CLS. 13, 21, 23, 31 AND 34).

ANNE MADDEN, EXAMINING ATTORNEY

CLASS 11—(Continued).

SN 85-290,181. LIGHTING SCIENCE GROUP CORPORATION, SATELLITE BEACH, FL. FILED 4-8-2011.

DEFINITY IQ

THE MARK CONSISTS OF STANDARD CHARACTERS WITHOUT CLAIM TO ANY PARTICULAR FONT, STYLE, SIZE, OR COLOR.

FOR LED LIGHTING FIXTURES AND LAMPS INCORPORATING WIRELESS CONTROLS (U.S. CLS. 13, 21, 23, 31 AND 34).

DOMINICK J. SALEMI, EXAMINING ATTORNEY

CLASS 11—(Continued).

SN 85-291,986. THOMASON, JOHN A., DBA METRO ENVIRONMENTAL SERVICES CO. INC., LEWISVILLE, TX. FILED 4-11-2011.

"Hassle Free"

THE MARK CONSISTS OF STANDARD CHARACTERS WITHOUT CLAIM TO ANY PARTICULAR FONT, STYLE, SIZE, OR COLOR.

FOR AIR CLEANING UNITS; AIR CLEANING UNITS CONTAINING AN AIR FILTER, ULTRAVIOLET LIGHTS AND A PHOTOCATALYTIC FILTER; AIR CONDITIONERS; AIR CONDITIONERS FOR VEHICLES; AIR CONDITIONING APPARATUS; AIR CONDITIONING APPARATUS AND INSTALLATIONS; AIR CONDITIONING INSTALLATIONS; AIR CONDITIONING PANELS FOR USE IN WALK-IN COOLERS; AIR CONDITIONING UNITS; AIR COOLING APPARATUS; AIR FILTERING INSTALLATIONS; AIR FILTERS FOR AIR CONDITIONERS IN VEHICLE PASSENGER COMPARTMENTS; AIR FILTERS FOR AIR CONDITIONING UNITS; AIR FILTERS FOR DOMESTIC USE; AIR FILTERS FOR INDUSTRIAL INSTALLATIONS; AIR HANDLERS; AIR PURIFICATION UNITS; AIR PURIFIERS; AIR PURIFIERS; AIR PURIFYING APPARATUS; AIR PURIFYING APPARATUS AND MACHINES; AIR-CONDITIONING APPARATUS; AIR-CONDITIONING APPARATUS AND INSTALLATIONS; AIR-CONDITIONING INSTALLATIONS; AIR-CONDITIONING, AIR COOLING AND VENTILATION APPARATUS AND INSTRUMENTS; CENTRAL AIR-CONDITIONING INSTALLATIONS; COMPONENTS FOR AIR CONDITIONING AND COOLING SYSTEMS, NAMELY, EVAPORATIVE AIR COOLERS; DAMPERS, NAMELY, CONTROL DEVICES USED IN AIR DUCTS TO REGULATE THE FLOW OF AIR; FANS FOR AIR CONDITIONING APPARATUS; FILTERS FOR AIR CONDITIONING; HEATING AND COOLING PANELS USED FOR INDOOR HEATING AND COOLING PURPOSES; HOUSEHOLD AIR CLEANERS; INDOOR RADIANT HEATING SYSTEMS; PARTS FOR HEATING AND AIR CONDITIONING SYSTEMS, NAMELY, HEATER CORES AND GAS COOLERS FOR VEHICLES (U.S. CLS. 13, 21, 23, 31 AND 34).

ALICE BENMAMAN, EXAMINING ATTORNEY

SN 85-291,776. CESY GROUP LLC, DAVIE, FL. FILED 4-11-2011.

ATMOS RX

THE MARK CONSISTS OF STANDARD CHARACTERS WITHOUT CLAIM TO ANY PARTICULAR FONT, STYLE, SIZE, OR COLOR.

FOR ELECTRIC VAPORIZERS (U.S. CLS. 13, 21, 23, 31 AND 34).

FIRST USE 3-7-2011; IN COMMERCE 3-7-2011.

MARK SPARACINO, EXAMINING ATTORNEY

SN 85-292,686. GEOGLOBAL PARTNERS, LLC, WEST PALM BEACH, FL. FILED 4-12-2011.

Devour

THE MARK CONSISTS OF STANDARD CHARACTERS WITHOUT CLAIM TO ANY PARTICULAR FONT, STYLE, SIZE, OR COLOR.

FOR AQUARIUM FILTRATION APPARATUS; FILTERS FOR FLUIDS, NAMELY, FOR WATER AND AREA-WATER SOLUTIONS; WATER STERILIZERS; WATER TREATMENT EQUIPMENT, NAMELY, WATER FILTRATION UNITS (U.S. CLS. 13, 21, 23, 31 AND 34).

GIANCARLO CASTRO, EXAMINING ATTORNEY

SN 85-291,808. CESY GROUP LLC, DAVIE, FL. FILED 4-11-2011.



THE MARK CONSISTS OF "ATMOS RX" IN A STYLIZED FONT, WITH THE LETTERS "A" AND "O" CONSISTING OF CIRCLES/SPHERES, AND THE LETTER "O" INCLUDING "RX".

FOR ELECTRIC VAPORIZERS (U.S. CLS. 13, 21, 23, 31 AND 34).

FIRST USE 3-7-2011; IN COMMERCE 3-7-2011.

MARK SPARACINO, EXAMINING ATTORNEY

CLASS 11—(Continued).

SN 85-293,034. ORECK HOLDINGS, LLC, NASHVILLE, TN. FILED 4-12-2011.

OPTIMAX

THE MARK CONSISTS OF STANDARD CHARACTERS WITHOUT CLAIM TO ANY PARTICULAR FONT, STYLE, SIZE, OR COLOR.

FOR AIR PURIFIERS (U.S. CLS. 13, 21, 23, 31 AND 34).
MARILYN IZZI, EXAMINING ATTORNEY

SN 85-293,239. TOTO U.S.A., INC., MORROW, GA. FILED 4-12-2011.

ROWAN

THE MARK CONSISTS OF STANDARD CHARACTERS WITHOUT CLAIM TO ANY PARTICULAR FONT, STYLE, SIZE, OR COLOR.

FOR PLUMBING FIXTURES, NAMELY, TOILETS (U.S. CLS. 13, 21, 23, 31 AND 34).
DAVID COLLIER, EXAMINING ATTORNEY

SN 85-294,676. AUSSMAK OPTOELECTRONICS CORP., TAINAN CITY 710, TAIWAN, FILED 4-13-2011.

SMAC

THE MARK CONSISTS OF STANDARD CHARACTERS WITHOUT CLAIM TO ANY PARTICULAR FONT, STYLE, SIZE, OR COLOR.

OWNER OF TAIWAN REG. NO. 01436854, DATED 11-1-2010, EXPIRES 10-31-2020.

FOR LIGHTING APPLIANCES, NAMELY, LAMPS, ELECTRIC LIGHT BULBS AND LIGHT-EMITTING DIODE (LED) LIGHTING MODULES; LIGHTING APPARATUS FOR TRANSPORT, NAMELY, TAIL LIGHTS, HEADLIGHTS, BRAKE LIGHTS, PARKING LIGHTS, WARNING LIGHTS, DIRECTION LIGHTS AND TIMING LIGHTS FOR VEHICLES; LIGHTING APPARATUS FOR AIRCRAFTS; ENERGY SAVING LAMPS; BATTEN SERIES LIGHTS, NAMELY, BATTEN LAMPS AND SHELF LIGHTS; SPIRAL LAMPS; FLUORESCENT LAMP TUBES; LIGHTING FIXTURES POWERED BY SOLAR ENERGY; EMBEDDED LIGHT-EMITTING DIODE (LED) LIGHTING FIXTURES; LIGHTING FIXTURES; LUMINOUS TUBES FOR LIGHTING; LAMP BULBS; DECORATIVE LAMPS; PROJECTION LAMPS; ELECTRIC LIGHTING FIXTURES, NAMELY, POWER FAILURE BACKUP SAFETY LIGHTING; ELECTRIC BULBS FOR SPIRAL LAMPS; DYNAMO-POWERED LAMPS FOR BICYCLES; COLD CATHODE FLUORESCENT LAMP (CCFL) TUBES FOR LIGHTING; COLD CATHODE FLUORESCENT LAMPS (CCFL); LIGHT-EMITTING DIODE (LED) LAMPS (U.S. CLS. 13, 21, 23, 31 AND 34).
ADA HAN, EXAMINING ATTORNEY

CLASS 11—(Continued).

SN 85-295,218. HOLLANDER, MARNIX ENGLISH, NEW YORK, NY. FILED 4-14-2011.

Polychroma

THE MARK CONSISTS OF STANDARD CHARACTERS WITHOUT CLAIM TO ANY PARTICULAR FONT, STYLE, SIZE, OR COLOR.

FOR OPTICAL LENS COVERS THAT IMPROVE LIGHT OUTPUT AND UNIFORMITY AND PROTECT THE LED, SOLD AS A FEATURE OF AN LED LIGHTING SYSTEM (U.S. CLS. 13, 21, 23, 31 AND 34).
LESLEY LAMOTHE, EXAMINING ATTORNEY

SN 85-295,408. SOCIEDAD ANONIMA MINERO CATALANO ARAGONESA, ZARAGOZA, SPAIN, FILED 4-14-2011.

SAMCATROUGH

THE MARK CONSISTS OF STANDARD CHARACTERS WITHOUT CLAIM TO ANY PARTICULAR FONT, STYLE, SIZE, OR COLOR.

OWNER OF ERP N CMNTY TM OFC REG. NO. 008135709, DATED 6-8-2010, EXPIRES 3-4-2019.

FOR APPARATUS FOR CONVERTING SOLAR ENERGY INTO THERMAL ENERGY, NAMELY, SOLAR TROUGH (U.S. CLS. 13, 21, 23, 31 AND 34).
APRIL ROACH, EXAMINING ATTORNEY

SN 85-308,346. PERFECT WATER TECHNOLOGIES, INC., SCOTTSDALE, AZ. FILED 4-29-2011.

HOME MASTER

THE MARK CONSISTS OF STANDARD CHARACTERS WITHOUT CLAIM TO ANY PARTICULAR FONT, STYLE, SIZE, OR COLOR.

NO CLAIM IS MADE TO THE EXCLUSIVE RIGHT TO USE "HOME", APART FROM THE MARK AS SHOWN.

FOR TAP-WATER PURIFYING APPARATUS; WATER TREATMENT EQUIPMENT, NAMELY, REVERSE OSMOSIS FILTRATION UNITS; WATER TREATMENT EQUIPMENT, NAMELY, CARTRIDGE FILTRATION UNITS; WATER TREATMENT EQUIPMENT, NAMELY, ULTRAVIOLET STERILIZATION UNITS; WATER FILTERS; WATER FILTERING APPARATUS; AND FILTERING UNITS FOR WATER FILTERING (U.S. CLS. 13, 21, 23, 31 AND 34).

FIRST USE 6-1-2004; IN COMMERCE 6-1-2004.
CIMMERIAN COLEMAN, EXAMINING ATTORNEY

CLASS 11—(Continued).

SN 85-308,549. COAST PRODUCTS, L.L.C., PANAMA CITY, FL. FILED 4-29-2011.

1B1

THE MARK CONSISTS OF STANDARD CHARACTERS WITHOUT CLAIM TO ANY PARTICULAR FONT, STYLE, SIZE, OR COLOR.

FOR WATER CONTROL VALVES FOR USE IN TOILETS (U.S. CLS. 13, 21, 23, 31 AND 34).

FIRST USE 12-31-1959; IN COMMERCE 12-31-1959.

RICHARD WHITE, EXAMINING ATTORNEY

CLASS 11—(Continued).

SN 85-324,919. EXCEL DRYER, INC., EAST LONGMEADOW, MA. FILED 5-19-2011.

XCHANGER

THE MARK CONSISTS OF STANDARD CHARACTERS WITHOUT CLAIM TO ANY PARTICULAR FONT, STYLE, SIZE, OR COLOR.

FOR ELECTRIC WALL-MOUNTED HAND DRYER KIT COMPRISED PRIMARILY OF ELECTRIC WALL-MOUNTED HAND DRYER AND WALL MOUNT (U.S. CLS. 13, 21, 23, 31 AND 34).

SKYE YOUNG, EXAMINING ATTORNEY

SN 85-311,025. LIGHTING SCIENCE GROUP CORPORATION, SATELLITE BEACH, FL. FILED 5-3-2011.

WiLight

THE MARK CONSISTS OF STANDARD CHARACTERS WITHOUT CLAIM TO ANY PARTICULAR FONT, STYLE, SIZE, OR COLOR.

FOR SOLID STATE LED LAMPS, BULBS, FIXTURES AND LUMINARES (U.S. CLS. 13, 21, 23, 31 AND 34).

DOMINICK J. SALEMI, EXAMINING ATTORNEY

SN 85-328,902. GENERAL ELECTRIC COMPANY, SCHENECTADY, NY. FILED 5-24-2011.

QUICKREPLACE

THE MARK CONSISTS OF STANDARD CHARACTERS WITHOUT CLAIM TO ANY PARTICULAR FONT, STYLE, SIZE, OR COLOR.

FOR WATER FILTERS (U.S. CLS. 13, 21, 23, 31 AND 34).

MICHAEL SOUDERS, EXAMINING ATTORNEY

SN 85-321,285. LIGHTING SCIENCE GROUP CORPORATION, SATELLITE BEACH, FL. FILED 5-15-2011.

PRIZMALINE

THE MARK CONSISTS OF STANDARD CHARACTERS WITHOUT CLAIM TO ANY PARTICULAR FONT, STYLE, SIZE, OR COLOR.

FOR LIGHTING FIXTURES (U.S. CLS. 13, 21, 23, 31 AND 34).

DOMINICK J. SALEMI, EXAMINING ATTORNEY

CLASS 12—VEHICLES

SN 79-090,413. SHAANXI HEAVY-DUTY AUTOMOBILE CO., LTD., 710200 SHAANXI, CHINA, FILED 10-8-2010.

SHACMAN

OWNER OF INTERNATIONAL REGISTRATION 1059697 DATED 10-8-2010, EXPIRES 10-8-2020.

THE WORDING "SHACMAN" HAS NO MEANING IN A FOREIGN LANGUAGE.

FOR AUTOMOBILES; VEHICLE CHASSIS; BODIES FOR VEHICLES; AUTOMOBILE TIRES AND TIRES (U.S. CLS. 19, 21, 23, 31, 35 AND 44).

DOMINIC FATHY, EXAMINING ATTORNEY

CLASS 12—(Continued).

SN 79-096,845. SHANDONG SANTAI RUBBER CO., LTD., CHINA, FILED 4-11-2011.

CLASS 12—(Continued).

SN 85-100,595. KHAN'S ENTERPRISE CO., LTD., TAOYUAN COUNTY 330, TAIWAN, FILED 8-5-2010.

ROCKSTON

PRIORITY DATE OF 11-2-2010 IS CLAIMED.
OWNER OF INTERNATIONAL REGISTRATION 1075603 DATED 4-11-2011, EXPIRES 4-11-2021.
FOR INNER TUBES FOR PNEUMATIC TIRES; TIRES FOR VEHICLE WHEELS; TIRES FOR BICYCLES, CYCLES; CASINGS FOR PNEUMATIC TIRES; PNEUMATIC TIRES; SOLID TIRES FOR VEHICLE WHEELS; VEHICLE WHEEL TIRES; AUTOMOBILE TIRES; INNER TUBES FOR BICYCLES, CYCLES; REPAIR OUTFITS FOR INNER TUBES (U.S. CLS. 19, 21, 23, 31, 35 AND 44).
MATTHEW EINSTEIN, EXAMINING ATTORNEY

FORMAR

THE MARK CONSISTS OF THE WORD "FORMAR" UNDERLINED BY A WAVING LINE WHICH STARTS BENEATH THE LETTER "O" AND RUNS TO THE END OF THE WORD.
THE ENGLISH TRANSLATION OF THE WORD "FORMAR" IN THE MARK IS "TO FORM".
FOR BOATS AND PARTS AND ACCESSORIES THEREFOR, NAMELY, CHOCKS, CLEATS, HOOKS AND STEERING WHEELS (U.S. CLS. 19, 21, 23, 31, 35 AND 44).
FIRST USE 8-2-2010; IN COMMERCE 8-2-2010.
LAURA KOVALSKY, EXAMINING ATTORNEY

SN 85-098,601. KHAN'S ENTERPRISE CO., LTD., TAOYUAN COUNTY 330, TAIWAN, FILED 8-2-2010.

SN 85-118,959. HENDRICKSON USA, LLC, ITASCA, IL. FILED 8-30-2010.



ULTIMAAX

THE MARK CONSISTS OF THE WORD "SEAWORLD" WITHIN AN ELLIPSE DESIGN, WITHIN AN OUTER ELLIPSE DESIGN.
FOR BOATS AND PARTS AND ACCESSORIES THEREFOR, NAMELY, CHOCKS, CLEATS, HOOKS AND STEERING WHEELS (U.S. CLS. 19, 21, 23, 31, 35 AND 44).
FIRST USE 5-30-2008; IN COMMERCE 5-30-2008.
LAURA KOVALSKY, EXAMINING ATTORNEY

THE MARK CONSISTS OF STANDARD CHARACTERS WITHOUT CLAIM TO ANY PARTICULAR FONT, STYLE, SIZE, OR COLOR.
FOR LAND VEHICLE SUSPENSIONS AND STRUCTURAL PARTS AND SUB-ASSEMBLIES (U.S. CLS. 19, 21, 23, 31, 35 AND 44).
PRISCILLA MILTON, EXAMINING ATTORNEY

CLASS 12—(Continued).

SN 85-137,270. ASTILEAN, ALEX, EAST HAMPTON, NY.
FILED 9-24-2010.

SPEEDMOBILE

THE MARK CONSISTS OF STANDARD CHARACTERS WITHOUT CLAIM TO ANY PARTICULAR FONT, STYLE, SIZE, OR COLOR.

FOR VEHICLES FOR LOCOMOTION BY LAND, NAMELY, LAND VEHICLE PROPELLED BY FOOT POWERED TREADMILL (U.S. CLS. 19, 21, 23, 31, 35 AND 44).

FIRST USE 2-7-2007; IN COMMERCE 1-10-2008.
SANI KHOURI, EXAMINING ATTORNEY

SN 85-149,644. FRANK MIYAKE, ENCINITAS, CA. FILED
10-11-2010.

NOTAKO

THE MARK CONSISTS OF STANDARD CHARACTERS WITHOUT CLAIM TO ANY PARTICULAR FONT, STYLE, SIZE, OR COLOR.

THE WORDING "NOTAKO" HAS NO MEANING IN A FOREIGN LANGUAGE.

FOR WHEEL RIMS FOR MOTORCYCLES (U.S. CLS. 19, 21, 23, 31, 35 AND 44).

FIRST USE 2-0-2009; IN COMMERCE 2-0-2009.
JULIE WATSON, EXAMINING ATTORNEY

SN 85-196,346. VAN BORTEL AIRCRAFT, INC., DBA AIR
POWER, ARLINGTON, TX. FILED 12-13-2010.

BE GENUINE

THE MARK CONSISTS OF STANDARD CHARACTERS WITHOUT CLAIM TO ANY PARTICULAR FONT, STYLE, SIZE, OR COLOR.

FOR BRAKE SYSTEMS FOR AIRCRAFT, NAMELY, BRAKE DISCS AND BRAKE PADS; WHEELS, TIRES AND TIRE TUBES FOR AIRCRAFT TIRES; STRUCTURAL PARTS OF AIRCRAFT INCLUDING WINDOWS, WINDSHIELDS, PROPELLERS, ENGINE COVERS, COWLING AND DOORS; PNEUMATIC DEICERS FOR AIRCRAFT; VEHICLE TOW BARS (U.S. CLS. 19, 21, 23, 31, 35 AND 44).

DEBRA LEE, EXAMINING ATTORNEY

CLASS 12—(Continued).

SN 85-237,613. HUBBARD GLOBAL GROUP, FORT WORTH,
TX. FILED 2-9-2011.



OWNER OF U.S. REG. NOS. 3,788,660, 3,895,443 AND 3,959,959.

NO CLAIM IS MADE TO THE EXCLUSIVE RIGHT TO USE "TIRE AND RUBBER" AND "HOT ROD UHP", APART FROM THE MARK AS SHOWN.

THE MARK CONSISTS OF SHIELD THAT SAYS "ROUTE 66 TIRE AND RUBBER", FOLLOWED BY THE WORDS "HOT ROD UHP".

FOR TIRES FOR VEHICLES (U.S. CLS. 19, 21, 23, 31, 35 AND 44).

JASON TURNER, EXAMINING ATTORNEY

SN 85-243,927. TOYO TIRE & RUBBER CO., LTD., OSAKA,
JAPAN, FILED 2-16-2011.

MUD GRAPPLER

THE MARK CONSISTS OF STANDARD CHARACTERS WITHOUT CLAIM TO ANY PARTICULAR FONT, STYLE, SIZE, OR COLOR.

OWNER OF U.S. REG. NOS. 3,127,293, 3,390,759 AND OTHERS.

FOR TIRES FOR VEHICLES, INNER TUBES FOR VEHICLE TIRES AND WHEELS FOR VEHICLES (U.S. CLS. 19, 21, 23, 31, 35 AND 44).

FIRST USE 2-0-2004; IN COMMERCE 2-0-2004.
BRIDGETT SMITH, EXAMINING ATTORNEY

SN 85-258,174. TRACTOR SUPPLY CO. OF TEXAS, LP,
BRENTWOOD, TN. FILED 3-4-2011.

COUNTYLINE

THE MARK CONSISTS OF STANDARD CHARACTERS WITHOUT CLAIM TO ANY PARTICULAR FONT, STYLE, SIZE, OR COLOR.

OWNER OF U.S. REG. NOS. 3,475,488 AND 3,806,658.
FOR TRACTOR PARTS, NAMELY, POWER TAKE-OFF YOKES, SHAFTS AND CROSS BEARINGS; TRACTOR PARTS, NAMELY, REAR THREE POINT LINKAGE (U.S. CLS. 19, 21, 23, 31, 35 AND 44).

KATHLEEN LORENZO, EXAMINING ATTORNEY

CLASS 12—(Continued).

SN 85-261,883. SAFETY FIRST SOLUTIONS, LLC, MACON, GA. FILED 3-9-2011.



NO CLAIM IS MADE TO THE EXCLUSIVE RIGHT TO USE "DRIVER'S ALERT", APART FROM THE MARK AS SHOWN.

THE COLOR(S) ARE BLACK, RED, WHITE. IS/ARE CLAIMED AS A FEATURE OF THE MARK.

THE MARK CONSISTS OF A PERSON, A BLACK HEAD AND A BLACK ARM, BEHIND A BLACK WHEEL OF A CAR DOZING OFF TO SLEEP. THIS ACTION IS DEPICTED BY A SECOND RED HEAD OUTLINED IN WHITE COMING FORWARD. THERE ARE TWO RED LIGHTING BOLTS OUTLINED IN WHITE COMING OUT OF THE BACK OF THE BLACK HEAD THAT REPRESENT DISTRESS OR BEING DROWSY. THIS SCENE IS HAPPENING IN FRONT OF WHAT APPEARS TO BE A RED ALERT SIGN. OVER TOP OF THE HEAD IT READS IN RED LETTERS "DRIVER'S" OUTLINED IN WHITE AND BLACK, AND UNDERNEATH THE DRIVER IT READS "ALERT" IN RED OUTLINED IN WHITE AND BLACK.

FOR CAR SAFETY EQUIPMENT, NAMELY, AN ELECTRONIC DEVICE THAT ALERTS USERS WHO ARE BECOMING DROWSY WITH VARIABLE ALERT SOUNDS AND REQUIRES THEM TO STAY PHYSICALLY ENGAGED (U.S. CLS. 19, 21, 23, 31, 35 AND 44).
JILL PRATER, EXAMINING ATTORNEY

SN 85-270,819. CHAIR FLAIR, LLC, GRAND LEDGE, MI. FILED 3-18-2011.

CHAIRFLAIR

THE MARK CONSISTS OF STANDARD CHARACTERS WITHOUT CLAIM TO ANY PARTICULAR FONT, STYLE, SIZE, OR COLOR.

FOR SEAT COVERS FOR WHEELCHAIRS (U.S. CLS. 19, 21, 23, 31, 35 AND 44).

MARY CRAWFORD, EXAMINING ATTORNEY

CLASS 12—(Continued).

SN 85-270,853. CHAIR FLAIR, LLC, GRAND LEDGE, MI. FILED 3-18-2011.



THE MARK CONSISTS OF THE LETTERS "C" AND "F" IN A CIRCLE WHEREIN THE LOWER PORTION OF THE "C" EXTENDS BELOW THE BOTTOM OF THE "F" AND THE "F" HAS A CIRCLE DISPOSED ABOVE IT WITH THE COMBINATION FORMING A STYLIZED DEPICTION OF THE HANDICAPPED SYMBOL.

FOR SEAT COVERS FOR WHEELCHAIRS (U.S. CLS. 19, 21, 23, 31, 35 AND 44).

MARY CRAWFORD, EXAMINING ATTORNEY

SN 85-272,330. TOYO TIRE & RUBBER CO., LTD., OSAKA, JAPAN, FILED 3-21-2011.

TERRA GRAPPLER

THE MARK CONSISTS OF STANDARD CHARACTERS WITHOUT CLAIM TO ANY PARTICULAR FONT, STYLE, SIZE, OR COLOR.

OWNER OF U.S. REG. NOS. 3,127,293, 3,390,759 AND OTHERS.

FOR TIRES FOR VEHICLES, INNER TUBES FOR VEHICLE TIRES AND WHEELS FOR VEHICLES (U.S. CLS. 19, 21, 23, 31, 35 AND 44).

FIRST USE 3-0-2002; IN COMMERCE 3-0-2002.

BRIDGETT SMITH, EXAMINING ATTORNEY

SN 85-272,817. D'ERRICO, JONAH, PALM BAY, FL. AND DAVE, JASON, GOLETA, CA. FILED 3-21-2011.

Premium Sportway

THE MARK CONSISTS OF STANDARD CHARACTERS WITHOUT CLAIM TO ANY PARTICULAR FONT, STYLE, SIZE, OR COLOR.

NO CLAIM IS MADE TO THE EXCLUSIVE RIGHT TO USE "PREMIUM", APART FROM THE MARK AS SHOWN. FOR TIRES (U.S. CLS. 19, 21, 23, 31, 35 AND 44).

ZACHARY BELLO, EXAMINING ATTORNEY

CLASS 12—(Continued).

SN 85-274,323. VISION WHEEL, INC., DECATUR, AL. FILED 3-23-2011.

PRADO

THE MARK CONSISTS OF STANDARD CHARACTERS WITHOUT CLAIM TO ANY PARTICULAR FONT, STYLE, SIZE, OR COLOR.

THE ENGLISH TRANSLATION OF "PRADO" IS "MEADOW".

FOR CUSTOM WHEELS (U.S. CLS. 19, 21, 23, 31, 35 AND 44).

CHARLES L. JENKINS, EXAMINING ATTORNEY

SN 85-274,578. PORTEON ELECTRIC VEHICLES, INC., PORTLAND, OR. FILED 3-23-2011.

PORTEON

THE MARK CONSISTS OF STANDARD CHARACTERS WITHOUT CLAIM TO ANY PARTICULAR FONT, STYLE, SIZE, OR COLOR.

FOR MOTOR LAND VEHICLES, NAMELY, AUTOMOBILES, MOTORCYCLES, MOTORIZED SCOOTERS, SPORTS UTILITY VEHICLES, TRUCKS, AND VANS; MOTORS FOR LAND VEHICLES; STRUCTURAL PARTS FOR LAND VEHICLES (U.S. CLS. 19, 21, 23, 31, 35 AND 44).

KELLY CHOE, EXAMINING ATTORNEY

SN 85-274,613. VISION WHEEL, INC., DECATUR, AL. FILED 3-23-2011.



THE COLOR(S) RED AND GRAY IS/ARE CLAIMED AS A FEATURE OF THE MARK.

THE MARK CONSISTS OF THE WORD "PRADO" IN GRAY, WITH THE CROSS-BAR OF THE LETTER "A" REPRESENTED BY AN UPSIDE-DOWN RED TRIANGLE.

THE ENGLISH TRANSLATION OF "PRADO" IS "MEADOW".

FOR CUSTOM WHEELS (U.S. CLS. 19, 21, 23, 31, 35 AND 44).

CHARLES L. JENKINS, EXAMINING ATTORNEY

CLASS 12—(Continued).

SN 85-277,441. DUBINSKIY, YURIY, LAKE ZURICH, IL. AND GOROKHOVSKY, ALEXANDER, DEERFIELD, IL. FILED 3-25-2011.

EDGE LEATHER

THE MARK CONSISTS OF STANDARD CHARACTERS WITHOUT CLAIM TO ANY PARTICULAR FONT, STYLE, SIZE, OR COLOR.

NO CLAIM IS MADE TO THE EXCLUSIVE RIGHT TO USE "LEATHER", APART FROM THE MARK AS SHOWN.

FOR MOTORCYCLE SADDLEBAGS (U.S. CLS. 19, 21, 23, 31, 35 AND 44).

FIRST USE 10-1-2007; IN COMMERCE 1-1-2008.

MARIA-VICTORIA SUAREZ, EXAMINING ATTORNEY

SN 85-279,086. THOMAS M. TRABUE JR., WHITE BLUFF, TN. FILED 3-28-2011.



THE MARK CONSISTS OF THE STYLIZED WORD "SLIPSTREAM". THE TERM IS UNDERLINED AND THE FIRST LETTER "S" EXTENDS DOWN BELOW THE UNDERLINING.

FOR LIGHTWEIGHT UTILITY MOTOR VEHICLE TRAILERS (U.S. CLS. 19, 21, 23, 31, 35 AND 44).

FIRST USE 6-25-1980; IN COMMERCE 6-25-1980.

JAMES LOVELACE, EXAMINING ATTORNEY

SN 85-281,109. CHRYSLER GROUP LLC, AUBURN HILLS, MI. FILED 3-30-2011.

RAM 1500 EXPRESS

THE MARK CONSISTS OF STANDARD CHARACTERS WITHOUT CLAIM TO ANY PARTICULAR FONT, STYLE, SIZE, OR COLOR.

OWNER OF U.S. REG. NOS. 2,993,078, 3,806,969 AND OTHERS.

FOR MOTOR VEHICLES, NAMELY, PASSENGER AUTOMOBILES, THEIR STRUCTURAL PARTS, TRIM AND BADGES (U.S. CLS. 19, 21, 23, 31, 35 AND 44).

TINA BROWN, EXAMINING ATTORNEY

CLASS 12—(Continued).

SN 85-282,324. STAFFORD, RONAN, CLONTARD, DUBLIN, IRELAND, FILED 3-31-2011.

DEMON

THE MARK CONSISTS OF STANDARD CHARACTERS WITHOUT CLAIM TO ANY PARTICULAR FONT, STYLE, SIZE, OR COLOR.

FOR BICYCLE PARTS AND ACCESSORIES, NAMELY, CHAIN RINGS, CRANK SETS, BOTTOM BRACKETS, HEADSETS, HUBS, STEMS, SEATPOSTS, HANDLEBARS, HANDLEBAR GRIPS AND CHAIN RING BOLTS AND EXCLUDING TIRES, ALL FOR USE ON MOUNTAIN BIKES, AND ALL NOT FOR USE ON MOTORIZED CYCLES OR MOTORCYCLES (U.S. CLS. 19, 21, 23, 31, 35 AND 44).

NORA BUCHANAN WILL, EXAMINING ATTORNEY

SN 85-286,608. WOLO MANUFACTURING CORP., DEER PARK, NY. FILED 4-5-2011.

AIR MAX

THE MARK CONSISTS OF STANDARD CHARACTERS WITHOUT CLAIM TO ANY PARTICULAR FONT, STYLE, SIZE, OR COLOR.

NO CLAIM IS MADE TO THE EXCLUSIVE RIGHT TO USE "AIR", APART FROM THE MARK AS SHOWN.

FOR HORNS FOR VEHICLES (U.S. CLS. 19, 21, 23, 31, 35 AND 44).

FIRST USE 4-15-2002; IN COMMERCE 4-15-2002.
EDWARD NELSON, EXAMINING ATTORNEY

SN 85-289,050. FULLRUN TYRE CORP. LTD., QINGDAO, CHINA, FILED 4-7-2011.

FULLWAY

THE MARK CONSISTS OF STANDARD CHARACTERS WITHOUT CLAIM TO ANY PARTICULAR FONT, STYLE, SIZE, OR COLOR.

FOR ADHESIVE RUBBER PATCHES FOR REPAIRING TUBES OR TIRES; AIRPLANES AND STRUCTURAL PARTS THEREFOR; BOATS AND STRUCTURAL PARTS THEREFOR; CASINGS FOR PNEUMATIC TIRES; INNER TUBES FOR VEHICLE TIRES; LAND VEHICLE PARTS, NAMELY, WHEELS; LAND VEHICLES AND STRUCTURAL PARTS THEREFOR; PATCHES FOR REPAIRING INNER TUBES; PNEUMATIC TYRES AND INNER TUBES FOR MOTORCYCLES; TIRES; TREADS FOR RETREADING TYRES FOR FORESTRY VEHICLES; VEHICLE WHEELS; VESSELS (U.S. CLS. 19, 21, 23, 31, 35 AND 44).

FIRST USE 4-20-2009; IN COMMERCE 4-23-2009.
DAWN HAN, EXAMINING ATTORNEY

CLASS 12—(Continued).

SN 85-289,795. NEXEN TIRE CORPORATION, KYONG-SANGNAM-DO., REPUBLIC OF KOREA, FILED 4-8-2011.

N'priz

THE MARK CONSISTS OF STANDARD CHARACTERS WITHOUT CLAIM TO ANY PARTICULAR FONT, STYLE, SIZE, OR COLOR.

FOR INNER TUBES FOR PNEUMATIC TIRES, TIRES FOR VEHICLE WHEELS, SOLID TIRES FOR VEHICLE WHEELS, TIRE FLAPS FOR PROTECTION OF INNER TUBE WITHIN WHEEL RIM (U.S. CLS. 19, 21, 23, 31, 35 AND 44).

GENE MACIOL, EXAMINING ATTORNEY

SN 85-290,179. TOYO TIRE & RUBBER CO., LTD., OSAKA, JAPAN, FILED 4-8-2011.

ECO GEN

THE MARK CONSISTS OF STANDARD CHARACTERS WITHOUT CLAIM TO ANY PARTICULAR FONT, STYLE, SIZE, OR COLOR.

OWNER OF U.S. REG. NO. 2,915,628.

NO CLAIM IS MADE TO THE EXCLUSIVE RIGHT TO USE "ECO", APART FROM THE MARK AS SHOWN.

FOR TIRES FOR VEHICLES, INNER TUBES FOR VEHICLE TIRES AND WHEELS FOR VEHICLES (U.S. CLS. 19, 21, 23, 31, 35 AND 44).

BRIDGETT SMITH, EXAMINING ATTORNEY

SN 85-290,726. HONDA MOTOR CO., LTD., TOKYO, JAPAN, FILED 4-8-2011.

ACURA AX SERIES

THE MARK CONSISTS OF STANDARD CHARACTERS WITHOUT CLAIM TO ANY PARTICULAR FONT, STYLE, SIZE, OR COLOR.

OWNER OF U.S. REG. NOS. 1,407,602, 2,964,304 AND OTHERS.

NO CLAIM IS MADE TO THE EXCLUSIVE RIGHT TO USE "SERIES", APART FROM THE MARK AS SHOWN.

FOR AUTOMOBILES AND STRUCTURAL PARTS THEREFOR (U.S. CLS. 19, 21, 23, 31, 35 AND 44).

ZACHARY BELLO, EXAMINING ATTORNEY

CLASS 12—(Continued).

SN 85-290,729. HONDA MOTOR CO., LTD., TOKYO, JAPAN,
FILED 4-8-2011.

ACURA AX6

THE MARK CONSISTS OF STANDARD CHARACTERS
WITHOUT CLAIM TO ANY PARTICULAR FONT, STYLE,
SIZE, OR COLOR.

OWNER OF U.S. REG. NOS. 1,407,602, 2,964,304 AND
OTHERS.

FOR AUTOMOBILES AND STRUCTURAL PARTS
THEREFOR (U.S. CLS. 19, 21, 23, 31, 35 AND 44).
ZACHARY BELLO, EXAMINING ATTORNEY

CLASS 12—(Continued).

SN 85-290,735. HONDA MOTOR CO., LTD., TOKYO, JAPAN,
FILED 4-8-2011.

AX6

THE MARK CONSISTS OF STANDARD CHARACTERS
WITHOUT CLAIM TO ANY PARTICULAR FONT, STYLE,
SIZE, OR COLOR.

FOR AUTOMOBILES AND STRUCTURAL PARTS
THEREFOR (U.S. CLS. 19, 21, 23, 31, 35 AND 44).
ZACHARY BELLO, EXAMINING ATTORNEY

SN 85-290,731. HONDA MOTOR CO., LTD., TOKYO, JAPAN,
FILED 4-8-2011.

ACURA AX4

THE MARK CONSISTS OF STANDARD CHARACTERS
WITHOUT CLAIM TO ANY PARTICULAR FONT, STYLE,
SIZE, OR COLOR.

OWNER OF U.S. REG. NOS. 1,407,602, 2,964,304 AND
OTHERS.

FOR AUTOMOBILES AND STRUCTURAL PARTS
THEREFOR (U.S. CLS. 19, 21, 23, 31, 35 AND 44).
ZACHARY BELLO, EXAMINING ATTORNEY

SN 85-290,736. HONDA MOTOR CO., LTD., TOKYO, JAPAN,
FILED 4-8-2011.

AX4

THE MARK CONSISTS OF STANDARD CHARACTERS
WITHOUT CLAIM TO ANY PARTICULAR FONT, STYLE,
SIZE, OR COLOR.

FOR AUTOMOBILES AND STRUCTURAL PARTS
THEREFOR (U.S. CLS. 19, 21, 23, 31, 35 AND 44).
ZACHARY BELLO, EXAMINING ATTORNEY

SN 85-290,733. HONDA MOTOR CO., LTD., TOKYO, JAPAN,
FILED 4-8-2011.

ACURA AX2

THE MARK CONSISTS OF STANDARD CHARACTERS
WITHOUT CLAIM TO ANY PARTICULAR FONT, STYLE,
SIZE, OR COLOR.

OWNER OF U.S. REG. NOS. 1,407,602, 2,964,304 AND
OTHERS.

FOR AUTOMOBILES AND STRUCTURAL PARTS
THEREFOR (U.S. CLS. 19, 21, 23, 31, 35 AND 44).
ZACHARY BELLO, EXAMINING ATTORNEY

SN 85-290,741. HONDA MOTOR CO., LTD., TOKYO, JAPAN,
FILED 4-8-2011.

AX2

THE MARK CONSISTS OF STANDARD CHARACTERS
WITHOUT CLAIM TO ANY PARTICULAR FONT, STYLE,
SIZE, OR COLOR.

FOR AUTOMOBILES AND STRUCTURAL PARTS
THEREFOR (U.S. CLS. 19, 21, 23, 31, 35 AND 44).
ZACHARY BELLO, EXAMINING ATTORNEY

CLASS 12—(Continued).

SN 85-291,047. VAN KORT, CAROLYN, COOS BAY, OR. FILED 4-9-2011.



FOR FITTED FABRIC COVERS FOR VEHICLE SEAT BELTS (U.S. CLS. 19, 21, 23, 31, 35 AND 44). FIRST USE 5-11-2010; IN COMMERCE 6-21-2010. GEORGE LORENZO, EXAMINING ATTORNEY



SN 85-291,617. DANA LIMITED, MAUMEE, OH. FILED 4-11-2011.

PRO-40

THE MARK CONSISTS OF STANDARD CHARACTERS WITHOUT CLAIM TO ANY PARTICULAR FONT, STYLE, SIZE, OR COLOR. FOR AXLES FOR VEHICLES (U.S. CLS. 19, 21, 23, 31, 35 AND 44). ANDREW LEASER, EXAMINING ATTORNEY



SN 85-292,463. HLI OPERATING COMPANY, INC., NORTHVILLE, MI. FILED 4-12-2011.

CENTRUCOAT

THE MARK CONSISTS OF STANDARD CHARACTERS WITHOUT CLAIM TO ANY PARTICULAR FONT, STYLE, SIZE, OR COLOR. FOR WHEELS FOR LAND VEHICLES (U.S. CLS. 19, 21, 23, 31, 35 AND 44). EMILY CARLSEN, EXAMINING ATTORNEY

CLASS 12—(Continued).

SN 85-292,548. DAN WEATHERLY, EUFALA, OK. FILED 4-12-2011.



THE MARK CONSISTS OF THE LETTER "V" INSIDE THE LETTER "Y". FOR MOTOR LAND VEHICLES, NAMELY, AUTOMOBILES, ENGINES THEREFORE, AND STRUCTURAL PARTS THEREOF (U.S. CLS. 19, 21, 23, 31, 35 AND 44). NICHOLAS COLEMAN, EXAMINING ATTORNEY



SN 85-292,569. MOBILITY HOLDINGS, LIMITED, WAN-CHAI, HONG KONG, FILED 4-12-2011.



THE MARK CONSISTS OF A STYLIZED DEPICTION OF A FLYING ORIGAMI BIRD. FOR BICYCLES; BICYCLE SADDLES; COVERS FOR BICYCLE SADDLES, BICYCLE SEAT POSTS; AIR PUMPS FOR BICYCLES FOR THE INFLATION OF TYRES; BICYCLE TRAILERS, BICYCLE STANDS; BASKETS ADAPTED FOR BICYCLES; PEDALS FOR BICYCLES; COVERS FOR FOOT PEDALS ON CYCLES; BICYCLE HUBS; FITTED BICYCLE COVERS; PANNIER BAGS FOR BICYCLES; WATER BOTTLE HOLDERS FOR BICYCLES; BICYCLE CARRIERS FOR VEHICLES; BICYCLE PARTS, NAMELY, BRAKES, BELLS, CHAINS, HANDLEBAR GRIPS, GRIP TAPE, CHAIN GUARDS FOR BICYCLES; STEERING DEVICES FOR BICYCLES, NAMELY, HANDLEBAR STEMS AND HANDLEPOSTS; MUDGUARDS FOR BICYCLES; SADDLEBAGS FOR BICYCLES; BICYCLE WHEELS, HUBS, RIMS AND STRUCTURAL PARTS THEREFOR (U.S. CLS. 19, 21, 23, 31, 35 AND 44). JASON BLAIR, EXAMINING ATTORNEY

CLASS 12—(Continued).

SN 85-293,512. BANUELOS, LAWRENCE FRANK, SAN JOSE, CA. FILED 4-12-2011.

BANUELOS ARTCYCLES

THE MARK CONSISTS OF STANDARD CHARACTERS WITHOUT CLAIM TO ANY PARTICULAR FONT, STYLE, SIZE, OR COLOR.

THE NAME(S), PORTRAIT(S), AND/OR SIGNATURE(S) SHOWN IN THE MARK IDENTIFIES LAWRENCE FRANK BANUELOS, WHOSE CONSENT(S) TO REGISTER IS MADE OF RECORD.

FOR BICYCLES (U.S. CLS. 19, 21, 23, 31, 35 AND 44).
FIRST USE 1-1-2011; IN COMMERCE 1-1-2011.
MARK SHINER, EXAMINING ATTORNEY

SN 85-293,514. BANUELOS, LAWRENCE FRANK, SAN JOSE, CA. FILED 4-12-2011.

ARTCYCLES

THE MARK CONSISTS OF STANDARD CHARACTERS WITHOUT CLAIM TO ANY PARTICULAR FONT, STYLE, SIZE, OR COLOR.

FOR BICYCLES (U.S. CLS. 19, 21, 23, 31, 35 AND 44).
FIRST USE 1-1-2011; IN COMMERCE 1-1-2011.
MARK SHINER, EXAMINING ATTORNEY

SN 85-294,294. DESIGNLINE CORPORATION, CHARLOTTE, NC. FILED 4-13-2011.



THE MARK CONSISTS OF "DESIGNLINE" WITH THE "D" BEING COMPRISED OF THREE CURVED ARROWS, AND AN IMAGE OF THE EARTH WITHIN THE "D".
FOR BUSES (U.S. CLS. 19, 21, 23, 31, 35 AND 44).
FIRST USE 3-2-2011; IN COMMERCE 3-2-2011.
THOMAS MANOR, EXAMINING ATTORNEY

CLASS 12—(Continued).

SN 85-294,465. SPLASH PRODUCTS, INC., EAGAN, MN. FILED 4-13-2011.

SAFEVIEW

THE MARK CONSISTS OF STANDARD CHARACTERS WITHOUT CLAIM TO ANY PARTICULAR FONT, STYLE, SIZE, OR COLOR.

FOR WINDSHIELD WIPER BLADES (U.S. CLS. 19, 21, 23, 31, 35 AND 44).
GEORGE LORENZO, EXAMINING ATTORNEY

SN 85-294,795. BONG HEE SUH, ROCKVILLE, MD. FILED 4-14-2011.

911 PARACHUTE

THE MARK CONSISTS OF STANDARD CHARACTERS WITHOUT CLAIM TO ANY PARTICULAR FONT, STYLE, SIZE, OR COLOR.

NO CLAIM IS MADE TO THE EXCLUSIVE RIGHT TO USE "PARACHUTE", APART FROM THE MARK AS SHOWN.

FOR PARACHUTES (U.S. CLS. 19, 21, 23, 31, 35 AND 44).
SHAILA SETTLES, EXAMINING ATTORNEY

SN 85-295,504. STEPHANIE SAIA, PLYMOUTH, MI. FILED 4-14-2011.



THE MARK CONSISTS OF SUN SETTING ON WAVES.
FOR CARTS, NAMELY, WHEELED, COLLAPSIBLE, CANVAS CARTS FOR TRANSPORTING AND HAULING OBJECTS (U.S. CLS. 19, 21, 23, 31, 35 AND 44).
JOHN GARTNER, EXAMINING ATTORNEY

CLASS 12—(Continued).

SN 85-296,819. FALKEN TIRE CORPORATION, FONTANA, CA. FILED 4-15-2011.

ID RATHER BE DRIFTING

THE MARK CONSISTS OF STANDARD CHARACTERS WITHOUT CLAIM TO ANY PARTICULAR FONT, STYLE, SIZE, OR COLOR.

FOR TIRES (U.S. CLS. 19, 21, 23, 31, 35 AND 44).
JESSICA A. POWERS, EXAMINING ATTORNEY

SN 85-298,268. HATCHIE CORPORATION, DBA HATCHIE BOTTOM, JACKSON, TN. FILED 4-19-2011.

ARMOUR-SUEDE

THE MARK CONSISTS OF STANDARD CHARACTERS WITHOUT CLAIM TO ANY PARTICULAR FONT, STYLE, SIZE, OR COLOR.

FOR AUTOMOTIVE ACCESSORIES, NAMELY, AUTOMOTIVE SEAT COVERS (U.S. CLS. 19, 21, 23, 31, 35 AND 44).

FIRST USE 4-30-2010; IN COMMERCE 4-30-2010.
ANNE MADDEN, EXAMINING ATTORNEY

SN 85-299,489. GOBBLER OIL RECOVERY BOATS LTD, AYLESBURY, UNITED KINGDOM, FILED 4-20-2011.

GOBBLER

THE MARK CONSISTS OF STANDARD CHARACTERS WITHOUT CLAIM TO ANY PARTICULAR FONT, STYLE, SIZE, OR COLOR.

OWNER OF UNITED KINGDOM REG. NO. 2562106, DATED 10-25-2010, EXPIRES 10-25-2020.

FOR OIL SPILL RECOVERY BOATS AND VESSELS, AND STRUCTURAL PARTS AND FITTINGS FOR BOATS AND VESSELS; TRANSPORT VEHICLES, TOW-TRUCKS AND TRAILERS FOR OIL SPILL RECOVERY BOATS AND VESSELS (U.S. CLS. 19, 21, 23, 31, 35 AND 44).

MICHAEL KEATING, EXAMINING ATTORNEY

CLASS 12—(Continued).

SN 85-299,494. GOBBLER OIL RECOVERY BOATS LTD, AYLESBURY, UNITED KINGDOM, FILED 4-20-2011.



OWNER OF UNITED KINGDOM REG. NO. 2562648, DATED 10-28-2010, EXPIRES 10-28-2020.

THE MARK CONSISTS OF CAPITAL LETTER "G" STYLIZED AS CONSUMING AN OIL DROP.

FOR OIL SPILL RECOVERY BOATS AND VESSELS; TRANSPORT VEHICLES, TOW-TRUCKS AND TRAILERS FOR OIL SPILL RECOVERY BOATS AND VESSELS (U.S. CLS. 19, 21, 23, 31, 35 AND 44).

MICHAEL KEATING, EXAMINING ATTORNEY

SN 85-310,533. LAND ROVER, WARWICK, UNITED KINGDOM, FILED 5-3-2011.



OWNER OF U.S. REG. NOS. 929,034, 2,100,825 AND OTHERS.

THE MARK CONSISTS OF THE LETTERS "RANGE ROVER" WITH THE WORD "RANGE" DIRECTLY ABOVE THE WORD "ROVER".

FOR AUTOMOBILES AND STRUCTURAL PARTS THEREFOR (U.S. CLS. 19, 21, 23, 31, 35 AND 44).

FIRST USE 9-30-2010, THE MARK WAS FIRST USED ANYWHERE IN A DIFFERENT FORM OTHER THAN THAT SOUGHT TO BE REGISTERED AT LEAST AS EARLY AS 02/08/1978. ; IN COMMERCE 9-30-2010, THE MARK WAS FIRST USED IN COMMERCE IN A DIFFERENT FORM OTHER THAN THAT SOUGHT TO BE REGISTERED AT LEAST AS EARLY AS 02/08/1978..

EMILY CARLSEN, EXAMINING ATTORNEY

CLASS 12—(Continued).

SN 85-311,779. CHRYSLER GROUP LLC, AUBURN HILLS, MI. FILED 5-4-2011.

GUTS. GLORY. RAM.

THE MARK CONSISTS OF STANDARD CHARACTERS WITHOUT CLAIM TO ANY PARTICULAR FONT, STYLE, SIZE, OR COLOR.

OWNER OF U.S. REG. NOS. 1,169,189, 2,999,082 AND OTHERS.

FOR MOTOR VEHICLES, NAMELY, PASSENGER AUTOMOBILES, THEIR STRUCTURAL PARTS, TRIM AND BADGES (U.S. CLS. 19, 21, 23, 31, 35 AND 44).

TINA BROWN, EXAMINING ATTORNEY

SN 85-315,910. WOLO MANUFACTURING CORP., DEER PARK, NY. FILED 5-9-2011.

PHILLY EXPRESS

THE MARK CONSISTS OF STANDARD CHARACTERS WITHOUT CLAIM TO ANY PARTICULAR FONT, STYLE, SIZE, OR COLOR.

OWNER OF U.S. REG. NO. 3,662,725.

FOR HORNS FOR VEHICLES (U.S. CLS. 19, 21, 23, 31, 35 AND 44).

FIRST USE 6-12-2008; IN COMMERCE 6-12-2008.

EDWARD NELSON, EXAMINING ATTORNEY

SN 85-315,961. WOLO MANUFACTURING CORP., DEER PARK, NY. FILED 5-9-2011.

WOBBLER

THE MARK CONSISTS OF STANDARD CHARACTERS WITHOUT CLAIM TO ANY PARTICULAR FONT, STYLE, SIZE, OR COLOR.

FOR HORNS FOR VEHICLES (U.S. CLS. 19, 21, 23, 31, 35 AND 44).

FIRST USE 2-2-1990; IN COMMERCE 2-2-1990.

EDWARD NELSON, EXAMINING ATTORNEY

CLASS 12—(Continued).

SN 85-319,071. CHRYSLER GROUP LLC, AUBURN HILLS, MI. FILED 5-12-2011.



OWNER OF U.S. REG. NOS. 1,169,189, 2,999,082 AND OTHERS.

NO CLAIM IS MADE TO THE EXCLUSIVE RIGHT TO USE "PRODUCTIONS", APART FROM THE MARK AS SHOWN.

THE MARK CONSISTS OF THE WORDING "GUTS GLORY RAM" WITH A DOT BETWEEN THE WORDS "GUTS" AND "GLORY" AND ANOTHER DOT BETWEEN THE WORDS "GLORY" AND "RAM". THE WORD "PRODUCTIONS" APPEARS CENTERED BELOW THE WORDING "GUTS GLORY RAM". THERE IS A RAM'S HEAD CENTERED BELOW THE WORDING WITH A HORIZONTAL LINE UNDERLINING THE WORDING, EXTENDING FROM EACH SIDE OF THE RAM'S HEAD. THERE IS ANOTHER HORIZONTAL LINE ABOVE THE WORDING "GUTS GLORY RAM".

FOR MOTOR VEHICLES, NAMELY, PASSENGER AUTOMOBILES, THEIR STRUCTURAL PARTS, TRIM AND BADGES (U.S. CLS. 19, 21, 23, 31, 35 AND 44).

TINA BROWN, EXAMINING ATTORNEY

CLASS 13—FIREARMS

SN 85-121,335. WILLEY, GLENN M., NORTHRIDGE, CA. FILED 9-1-2010.

Pet Defender

THE MARK CONSISTS OF STANDARD CHARACTERS WITHOUT CLAIM TO ANY PARTICULAR FONT, STYLE, SIZE, OR COLOR.

NO CLAIM IS MADE TO THE EXCLUSIVE RIGHT TO USE "PET", APART FROM THE MARK AS SHOWN.

FOR STUN GUNS SPECIFICALLY FOR USE ON ANIMALS (U.S. CLS. 2 AND 9).

FIRST USE 11-7-2007; IN COMMERCE 6-21-2010.

COURTNEY ALVAREZ, EXAMINING ATTORNEY

CLASS 13—(Continued).

SN 85-280,990. PATRIOT OUTFITTERS LLC, ST. MARYS, KS. FILED 3-30-2011.

TRUGUNNER

THE MARK CONSISTS OF STANDARD CHARACTERS WITHOUT CLAIM TO ANY PARTICULAR FONT, STYLE, SIZE, OR COLOR.

FOR FIREARM HOLSTERS, FIREARM MAGAZINE POUCHES, FIREARM SLINGS (U.S. CLS. 2 AND 9).
FIRST USE 3-5-2011; IN COMMERCE 3-5-2011.
JOHN GARTNER, EXAMINING ATTORNEY

SN 85-281,395. HI-VIZ INC., GAINESVILLE, TX. FILED 3-30-2011.

HI-VIZ

THE MARK CONSISTS OF STANDARD CHARACTERS WITHOUT CLAIM TO ANY PARTICULAR FONT, STYLE, SIZE, OR COLOR.

FOR BODIES OF SHELL (U.S. CLS. 2 AND 9).
TIMOTHY FINNEGAN, EXAMINING ATTORNEY

SN 85-284,031. HI-VIZ INC., GAINESVILLE, TX. FILED 4-1-2011.

HUNT GAME NOT SHELLS

THE MARK CONSISTS OF STANDARD CHARACTERS WITHOUT CLAIM TO ANY PARTICULAR FONT, STYLE, SIZE, OR COLOR.

FOR HUNTING GUN CARTRIDGES (U.S. CLS. 2 AND 9).
TIMOTHY FINNEGAN, EXAMINING ATTORNEY

CLASS 13—(Continued).

SN 85-292,111. SWAMY, NIGEL R, SUMNER, WA. FILED 4-11-2011.



NO CLAIM IS MADE TO THE EXCLUSIVE RIGHT TO USE "FIREWORKS", APART FROM THE MARK AS SHOWN.

THE MARK CONSISTS OF A WINGED CREST WITH TWO SWORDS AND A HORSE, WITH THE WORDING "MIGHTY KINGS FIREWORKS MK IX XXII MMVIII".
FOR FIREWORKS (U.S. CLS. 2 AND 9).
EMILY CARLSEN, EXAMINING ATTORNEY

SN 85-292,301. ZELDA, LLC, STURGIS, SD. FILED 4-11-2011.

COR-BON

THE MARK CONSISTS OF STANDARD CHARACTERS WITHOUT CLAIM TO ANY PARTICULAR FONT, STYLE, SIZE, OR COLOR.

FOR AMMUNITION (U.S. CLS. 2 AND 9).
FIRST USE 0-0-1982; IN COMMERCE 0-0-1982.
ANNE E. GUSTASON, EXAMINING ATTORNEY

SN 85-295,773. FULL RANGE PRECISION MACHINERY CO. LTD., HONG KONG, HONG KONG, FILED 4-14-2011.



THE MARK CONSISTS OF THE WORDING LDSMS WRITTEN ACROSS A FIREARM SCOPE, AND TO THE LEFT OF THIS WORDING, AN IMAGE OF A TARGETING SIGHT.

FOR FIREARM ATTACHMENTS, NAMELY, MOUNTS FOR ATTACHING GUN SIGHTS TO A FIREARM; FIREARM SIGHTS; FORESIGHTS FOR FIREARMS; GUNSIGHTS FOR FIREARMS; NOISE SUPPRESSORS FOR GUNS; NON-TELESCOPIC GUN SIGHTS FOR FIREARMS; SIGHTS, NAMELY, OPEN SIGHTS FOR USE ON FIREARMS (U.S. CLS. 2 AND 9).
FIRST USE 8-5-2009; IN COMMERCE 11-27-2010.
WON TEAK OH, EXAMINING ATTORNEY

CLASS 14—JEWELRY

SN 76-704,065. ALWAND VAHAN JEWELRY, LTD., MARONECK, NY. FILED 8-9-2010.

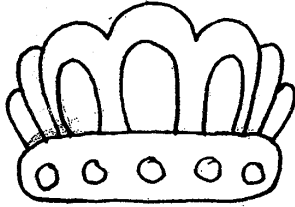

THE MARK CONSISTS OF A DESIGN OF A CROWN FOR JEWELRY (U.S. CLS. 2, 27, 28 AND 50). FIRST USE 6-15-2010; IN COMMERCE 6-15-2010. BERNICE MIDDLETON, EXAMINING ATTORNEY

SN 77-230,627. PHILIPPE CHARRIOL, 74120 MEGEVE, FRANCE, FILED 7-16-2007.

ST-TROPEZ

THE MARK CONSISTS OF STANDARD CHARACTERS WITHOUT CLAIM TO ANY PARTICULAR FONT, STYLE, SIZE, OR COLOR.

FOR WATCHES, WATCH BANDS, WATCH BANGLES, WATCH CHAINS AND WATCH PARTS (U.S. CLS. 2, 27, 28 AND 50).

FIRST USE 7-1-1988; IN COMMERCE 7-1-1988. MICHAEL ENGEL, EXAMINING ATTORNEY

SN 77-701,240. CHICTRONIC LLC, SANDY, UT. FILED 3-27-2009.

TANGERINE

THE MARK CONSISTS OF STANDARD CHARACTERS WITHOUT CLAIM TO ANY PARTICULAR FONT, STYLE, SIZE, OR COLOR.

FOR FASHION JEWELRY, NAMELY, BRACELETS, NECKLACES, RINGS, AND EARRINGS (U.S. CLS. 2, 27, 28 AND 50).

FIRST USE 9-30-2007; IN COMMERCE 9-30-2007. CHRISTINE COOPER, EXAMINING ATTORNEY

CLASS 14—(Continued).

SN 77-871,069. BLANCPAIN SA (BLANCPAIN AG) (BLANCPAIN LTD), 1348 LE BRASSUS, SWITZERLAND, FILED 11-12-2009.

500 FATHOMS

THE MARK CONSISTS OF STANDARD CHARACTERS WITHOUT CLAIM TO ANY PARTICULAR FONT, STYLE, SIZE, OR COLOR.

PRIORITY CLAIMED UNDER SEC. 44(D) ON SWITZERLAND APPLICATION NO. 56431/2009, FILED 6-11-2009, REG. NO. 590055, DATED 8-11-2009, EXPIRES 6-11-2019.

OWNER OF U.S. REG. NO. 661,036.

FOR HOROLOGICAL AND CHRONOMETRIC INSTRUMENTS (U.S. CLS. 2, 27, 28 AND 50).

FIRST USE 10-23-2009; IN COMMERCE 10-23-2009.

TRACY WHITTAKER-BROWN, EXAMINING ATTORNEY

SN 77-874,667. KIMORA LEE SIMMONS LICENSING, INC., NEW YORK, NY. FILED 11-17-2009.

KIMORA LEE SIMMONS

THE MARK CONSISTS OF STANDARD CHARACTERS WITHOUT CLAIM TO ANY PARTICULAR FONT, STYLE, SIZE, OR COLOR.

OWNER OF U.S. REG. NOS. 2,926,512, 3,419,783 AND 3,529,874.

THE NAME(S), PORTRAIT(S), AND/OR SIGNATURE(S) SHOWN IN THE MARK IDENTIFIES "KIMORA LEE SIMMONS", WHOSE CONSENT(S) TO REGISTER IS MADE OF RECORD.

FOR JEWELRY; JEWELRY FINDINGS; PENDANTS; LAPEL PINS; ORNAMENTAL LAPEL PINS; PINS BEING JEWELRY; EAR CLIPS; TIE PINS AND CLIPS; CUFFLINKS; COSTUME JEWELRY; JEWELRY CHAINS; JEWELRY PINS FOR USE ON HATS; HAT ORNAMENTS AND PINS OF PRECIOUS METAL; SHOE ORNAMENTS MADE OF PRECIOUS METAL; HOLIDAY ORNAMENTS OF PRECIOUS METAL; JEWELRY BOXES AND CASES OF PRECIOUS METAL; WATCHES AND RELATED ACCESSORIES; WRISTWATCHES; POCKET WATCHES; STOP WATCHES; WATCH STRAPS AND BANDS; WATCH CHAINS AND FOBS; WATCH CASES; CLOCKS; ALARM CLOCKS; CLOCKS INCORPORATING RADIOS; WALL CLOCKS; FIGURINES AND SCULPTURES OF PRECIOUS METAL; BOTTLE CLOSURES OF PRECIOUS METAL; BUSTS, FIGURINES, STATUES AND STATUETTES OF PRECIOUS METAL (U.S. CLS. 2, 27, 28 AND 50).

ESTHER A. BORSUK, EXAMINING ATTORNEY

CLASS 14—(Continued).

SN 79-094,630. PARMIGIANI FLEURIER SA, SWITZERLAND, FILED 2-17-2011.

TONDA TRANSFORMA

THE MARK CONSISTS OF STANDARD CHARACTERS WITHOUT CLAIM TO ANY PARTICULAR FONT, STYLE, SIZE, OR COLOR.

PRIORITY DATE OF 8-31-2010 IS CLAIMED.

OWNER OF INTERNATIONAL REGISTRATION 1069870 DATED 2-17-2011, EXPIRES 2-17-2021.

OWNER OF U.S. REG. NOS. 3,572,854 AND 3,747,073.

THE ENGLISH TRANSLATION OF "TRANSFORMA" IN THE MARK IS "TRANSFORMED". THE WORDING "TONDA" HAS NO MEANING IN A FOREIGN LANGUAGE.

FOR JEWELRY; CUFF LINKS, CHRONOMETRIC INSTRUMENTS, NAMELY, CLOCKS, WATCHES, POCKET WATCHES, WRISTWATCHES, WATCH BANDS, WATCH DIALS, WATCH MOVEMENTS, WATCH CASES (U.S. CLS. 2, 27, 28 AND 50).

TOBY BULLOFF, EXAMINING ATTORNEY

CLASS 14—(Continued).

SN 85-104,268. M.S.B.H. ALLIANCE, ANTWERP, BELGIUM, FILED 8-10-2010.

**GIVING YOUR DIAMOND ITS
DIVINE SPARK**

THE MARK CONSISTS OF STANDARD CHARACTERS WITHOUT CLAIM TO ANY PARTICULAR FONT, STYLE, SIZE, OR COLOR.

FOR JEWELRY MADE IN PART OR IN WHOLE WITH DIAMONDS; JEWELRY FINDINGS; GEMSTONE AND PRECIOUS STONES; SEMI-PRECIOUS STONES; PEARLS; OPALS; PLATINUM AND ITS ALLOYS; PRECIOUS METALS; CHARMS, CHOKERS, AND PENDANTS, MADE IN PART OR IN WHOLE WITH DIAMONDS; LAPEL PINS MADE IN PART OR IN WHOLE WITH DIAMONDS; ORNAMENTAL LAPEL PINS MADE IN PART OR IN WHOLE WITH DIAMONDS; PINS BEING JEWELRY MADE IN PART OR IN WHOLE WITH DIAMONDS; BODY-PIERCING RINGS AND STUDS MADE IN PART OR IN WHOLE WITH DIAMONDS; EAR STUDS MADE IN PART OR IN WHOLE WITH DIAMONDS; EAR CLIPS MADE IN PART OR IN WHOLE WITH DIAMONDS; TIE PINS MADE IN PART OR IN WHOLE WITH DIAMONDS; TIE CLIPS MADE IN PART OR IN WHOLE WITH DIAMONDS; TIE BARS MADE IN PART OR IN WHOLE WITH DIAMONDS; TIE TACKS MADE IN PART OR IN WHOLE WITH DIAMONDS; TIE FASTENERS MADE IN PART OR IN WHOLE WITH DIAMONDS; BOLO TIES WITH PRECIOUS METAL TIPS MADE IN PART OR IN WHOLE WITH DIAMONDS; CUFF-LINKS MADE IN PART OR IN WHOLE WITH DIAMONDS; SHIRT STUDS MADE IN PART OR IN WHOLE WITH DIAMONDS; BADGES OF PRECIOUS METAL; COSTUME JEWELRY; JEWELRY CHAINS; JEWELRY PINS FOR USE ON HATS MADE IN PART OR IN WHOLE WITH DIAMONDS; HAT ORNAMENTS OF PRECIOUS METAL MADE IN PART OR IN WHOLE WITH DIAMONDS; HOLIDAY ORNAMENTS OF PRECIOUS METAL MADE IN PART OR IN WHOLE WITH DIAMONDS; JEWELRY BOXES AND CASES MADE IN PART OR IN WHOLE WITH DIAMONDS; KEY HOLDERS OF PRECIOUS METALS MADE IN PART OR IN WHOLE WITH DIAMONDS; KEY CHAINS OF PRECIOUS METAL MADE IN PART OR IN WHOLE WITH DIAMONDS; WATCHES MADE IN PART OR IN WHOLE WITH DIAMONDS; WATCH BRACELETS MADE IN PART OR IN WHOLE WITH DIAMONDS; WATCH ACCESSORIES, NAMELY, PARTS FOR WATCHES MADE IN PART OR IN WHOLE WITH DIAMONDS; WRISTWATCHES MADE IN PART OR IN WHOLE WITH DIAMONDS; POCKET WATCHES MADE IN PART OR IN WHOLE WITH DIAMONDS; STOP WATCHES MADE IN PART OR IN WHOLE WITH DIAMONDS; WATCH STRAPS AND BANDS MADE IN PART OR IN WHOLE WITH DIAMONDS; WATCH CHAINS AND FOBS MADE IN PART OR IN WHOLE WITH DIAMONDS; WATCH CASES MADE IN PART OR IN WHOLE WITH DIAMONDS; WATCH BOXES MADE IN PART OR IN WHOLE WITH DIAMONDS; CLOCKS MADE IN PART OR IN WHOLE WITH DIAMONDS; ALARM CLOCKS MADE IN PART OR IN WHOLE WITH DIAMONDS; CLOCKS INCORPORATING RADIOS MADE IN PART OR IN WHOLE WITH DIAMONDS; WALL CLOCKS MADE IN PART OR IN WHOLE WITH DIAMONDS; TIMEPIECES MADE IN PART OR IN WHOLE WITH DIAMONDS; BOXES FOR TIMEPIECES MADE IN PART OR IN WHOLE WITH DIAMONDS; FIGURINES, SCULPTURES, BUSTS, FIGURES, STATUES, AND STATUETTES, ALL OF THE FOREGOING OF PRECIOUS METAL AND MADE IN PART WITH DIAMONDS (U.S. CLS. 2, 27, 28 AND 50).

JOHN DWYER, EXAMINING ATTORNEY

SN 85-043,814. TKS S.A., BASTOGNE, BELGIUM, FILED 5-20-2010.



NO CLAIM IS MADE TO THE EXCLUSIVE RIGHT TO USE "WATCH", APART FROM THE MARK AS SHOWN.

THE MARK CONSISTS OF A THREE-DIMENSIONAL CONFIGURATION OF PACKAGING FOR THE GOODS. THE ELEMENTS COMPRISING AND CLAIMED AS PART OF THE MARK ARE A SQUARE BOX OR CONTAINER FOR THE GOODS IN WHICH THERE IS A TRANSPARENT WINDOW WITH ROUNDED CORNERS AND FOUR CYLINDRICAL PROTRUSIONS AT THE TOP OF THE BOX; A WATCH CAN BE SEEN THROUGH THE TRANSPARENT WINDOW, AND EMBOSSED ON THE WINDOW ITSELF ARE THE WORDS "ICE WATCH" IN A FANCIFUL LOGO IN WHICH THE WORD "ICE" IS WRITTEN IN LARGER LOWERCASE LETTERS AND THE REPRESENTATION OF A GEM APPEARS AS THE DOT ON THE "I". THERE IS A LINE BENEATH THE WORD "ICE" AND THE WORD "WATCH" APPEARS BELOW THE LINE IN SMALLER LOWERCASE LETTERS. THE DOTTED LINES INDICATE MATTER WHICH IS NOT PART OF THE MARK AND SERVE TO SHOW THE POSITION OF THE GOODS WITHIN THE PACKAGING.

FOR HOROLOGICAL AND CHRONOMETRIC INSTRUMENTS, NAMELY, WATCHES (U.S. CLS. 2, 27, 28 AND 50).

FIRST USE 11-1-2008; IN COMMERCE 11-1-2008.

CYNTHIA SLOAN, EXAMINING ATTORNEY

CLASS 14—(Continued).

SN 85-128,620. GEORGETTE COOPER, LLC, LOS ANGELES, CA. FILED 9-13-2010.

Bling by the Yard

THE MARK CONSISTS OF STANDARD CHARACTERS WITHOUT CLAIM TO ANY PARTICULAR FONT, STYLE, SIZE, OR COLOR.

FOR BRACELETS; BROACHES; BRONZE JEWELRY; BROOCHES; CHARMS; CHARMS FOR COLLAR JEWELRY AND BRACELET; DIAMOND JEWELRY; GEMSTONE JEWELRY; GOLD THREAD JEWELRY; IDENTIFICATION BRACELETS; JEWELRY; JEWELRY AND IMITATION JEWELRY; JEWELRY BROOCHES; JEWELRY CHAINS; JEWELRY FOR ATTACHMENT TO CLOTHING; JEWELRY FOR THE HEAD; JEWELRY IN THE NATURE OF ARMBANDS; JEWELRY, NAMELY, AMULETS; JEWELRY, NAMELY, ANKLETS; JEWELRY, NAMELY, ARM CUFFS; JEWELRY, NAMELY, CROSSES; JEWELRY, NAMELY, STONE PENDANTS; NECKLACES; RINGS; RINGS BEING JEWELRY (U.S. CLS. 2, 27, 28 AND 50).

FIRST USE 8-9-2010; IN COMMERCE 8-9-2010.
LAURIE MAYES, EXAMINING ATTORNEY

SN 85-143,973. JOHNSTON, KELLIE, BUTTE, MT. FILED 10-4-2010.

SHIMMER & SHINE

THE MARK CONSISTS OF STANDARD CHARACTERS WITHOUT CLAIM TO ANY PARTICULAR FONT, STYLE, SIZE, OR COLOR.

FOR PRECIOUS METALS AND THEIR ALLOYS AND GOODS IN PRECIOUS METALS OR COATED THEREWITH, NAMELY, SMALL JEWELRY BOXES, CHARMS, STATUES, FIGURINES; JEWELRY, INCLUDING IMITATION JEWELRY AND PLASTIC JEWELRY (U.S. CLS. 2, 27, 28 AND 50).

LINDA ORNDORFF, EXAMINING ATTORNEY

SN 85-168,019. MPS ENTERTAINMENT, LLC, HOWELL, NJ. FILED 11-3-2010.

THE SITUATION

THE MARK CONSISTS OF STANDARD CHARACTERS WITHOUT CLAIM TO ANY PARTICULAR FONT, STYLE, SIZE, OR COLOR.

THE NAME(S), PORTRAIT(S), AND/OR SIGNATURE(S) SHOWN IN THE MARK IDENTIFIES MICHAEL SORRENTINO, WHOSE CONSENT(S) TO REGISTER IS MADE OF RECORD.

FOR JEWELRY (U.S. CLS. 2, 27, 28 AND 50).
WENDY GOODMAN, EXAMINING ATTORNEY

CLASS 14—(Continued).

SN 85-188,132. SCOTT KAY, INC., TEANECK, NJ. FILED 12-1-2010.

ARMOR COBALT

THE MARK CONSISTS OF STANDARD CHARACTERS WITHOUT CLAIM TO ANY PARTICULAR FONT, STYLE, SIZE, OR COLOR.

NO CLAIM IS MADE TO THE EXCLUSIVE RIGHT TO USE "COBALT", APART FROM THE MARK AS SHOWN.

FOR JEWELRY MADE IN WHOLE OR IN SUBSTANTIAL PART OF COBALT (U.S. CLS. 2, 27, 28 AND 50).
BARBARA A. GOLD, EXAMINING ATTORNEY

SN 85-213,055. SCOTT KAY, INC., TEANECK, NJ. FILED 1-7-2011.

BRUTETI

THE MARK CONSISTS OF STANDARD CHARACTERS WITHOUT CLAIM TO ANY PARTICULAR FONT, STYLE, SIZE, OR COLOR.

THE WORDING "BRUTETI" HAS NO MEANING IN A FOREIGN LANGUAGE.

FOR JEWELRY (U.S. CLS. 2, 27, 28 AND 50).
BARBARA A. GOLD, EXAMINING ATTORNEY

SN 85-220,998. OMEGA SA (OMEGA AG) (OMEGA LTD.), 2502 BIËL/BIENNE, SWITZERLAND, FILED 1-19-2011.

SPACEMASTER

THE MARK CONSISTS OF STANDARD CHARACTERS WITHOUT CLAIM TO ANY PARTICULAR FONT, STYLE, SIZE, OR COLOR.

PRIORITY CLAIMED UNDER SEC. 44(D) ON SWITZERLAND APPLICATION NO. 62838/2010, FILED 11-24-2010, REG. NO. 609194, DATED 12-14-2010, EXPIRES 11-24-2020.

FOR JEWELLERY; HOROLOGICAL AND CHRONOMETRIC INSTRUMENTS (U.S. CLS. 2, 27, 28 AND 50).
KAREN K. BUSH, EXAMINING ATTORNEY

CLASS 14—(Continued).

SN 85-226,242. MULHOLLAND, ADAM, AUGUSTA, GA. FILED 1-26-2011.



NO CLAIM IS MADE TO THE EXCLUSIVE RIGHT TO USE "MAJOR LEAGUE CHALLENGE COINS", APART FROM THE MARK AS SHOWN.

THE COLOR(S) WHITE, RED, BLACK AND BLUE IS/ARE CLAIMED AS A FEATURE OF THE MARK.

THE MARK CONSISTS OF A WHITE IMAGE OF A MAN LEANING OVER A WHITE STYLIZED "T" DESIGN. THE RIGHT BACKGROUND OF THE MAN IS RED AND THE LEFT BACKGROUND OF THE MAN IS BLUE. BELOW EVERYTHING IS THE RED WORDS "MAJOR LEAGUE CHALLENGE COINS". THERE IS A BLACK LINE IN THE SHAPE OF A SQUARE AND WHITE BORDER OUTLINING THE ENTIRE IMAGE.

FOR COLLECTIBLE COINS; COMMEMORATIVE COINS; NON-MONETARY COINS (U.S. CLS. 2, 27, 28 AND 50).

FIRST USE 1-12-2011; IN COMMERCE 1-12-2011.
VERNA BETH RIRIE, EXAMINING ATTORNEY

SN 85-266,067. SHAKE AWAKE PRODUCTS LLC, DBA IBON! LTD., GREAT FALLS, VA. FILED 3-14-2011.

SHAKE AWAKE

THE MARK CONSISTS OF STANDARD CHARACTERS WITHOUT CLAIM TO ANY PARTICULAR FONT, STYLE, SIZE, OR COLOR.

FOR ALARM CLOCKS; CLOCK CABINETS; CLOCK HOUSINGS; CLOCKS; CLOCKS AND PARTS THEREFOR; CLOCKS AND WATCHES; DESK CLOCKS; PARTS FOR CLOCKS; SMALL CLOCKS; TRAVEL CLOCKS; WATCHES, CLOCKS (U.S. CLS. 2, 27, 28 AND 50).

FIRST USE 12-31-1988; IN COMMERCE 12-31-1988.
TINA BROWN, EXAMINING ATTORNEY

SN 85-269,246. NES JEWELRY, INC., NEW YORK, NY. FILED 3-17-2011.

DIAMANTE BY NES

THE MARK CONSISTS OF STANDARD CHARACTERS WITHOUT CLAIM TO ANY PARTICULAR FONT, STYLE, SIZE, OR COLOR.

NO CLAIM IS MADE TO THE EXCLUSIVE RIGHT TO USE "DIAMANTE", APART FROM THE MARK AS SHOWN.

FOR JEWELRY INCLUDING STAINLESS STEEL JEWELRY AND DIAMONDS (U.S. CLS. 2, 27, 28 AND 50).

KATHERINE CHANG, EXAMINING ATTORNEY

CLASS 14—(Continued).

SN 85-271,075. JR DE BELLARD FINE JEWELRY INC, MIAMI, FL. FILED 3-18-2011.



NO CLAIM IS MADE TO THE EXCLUSIVE RIGHT TO USE "FINE JEWELRY", APART FROM THE MARK AS SHOWN.

THE NAME "JR DE BELLARD" IDENTIFIES A LIVING INDIVIDUAL WHOSE CONSENT IS OF RECORD.

THE MARK CONSISTS OF A STYLIZED DESIGN OF FOUR HEARTS THAT ARE JOINED TOGETHER TO FORM A CROSS APPEARING ON TOP OF THE WORDING "DE BELLARD FINE JEWELRY."

FOR ARTICLES MADE OF PRECIOUS METALS AND THEIR ALLOYS OR COATED THEREWITH, PRECIOUS STONES, SEMI-PRECIOUS STONES, NAMELY, JEWELRY; JEWELRY ARTICLES, NAMELY, FINGER RINGS, BRACELETS MADE OF LEATHER, EARRINGS OF PRECIOUS METAL, CUFFLINKS, BRACELETS OF PRECIOUS METAL, NECKLACES OF PRECIOUS METAL, PENDANTS OF PRECIOUS METAL, NECKLACES MADE OF LEATHER, CASES FOR JEWELRY (U.S. CLS. 2, 27, 28 AND 50).

JENNY PARK, EXAMINING ATTORNEY

SN 85-271,115. JR DE BELLARD FINE JEWELRY INC, MIAMI, FL. FILED 3-18-2011.



THE MARK CONSISTS OF A STYLIZED DESIGN OF FOUR HEARTS THAT ARE JOINED TOGETHER TO FORM A CROSS APPEARING ON TOP OF THE WORDING "DE BELLARD".

FOR ARTICLES MADE OF PRECIOUS METALS, AND THEIR ALLOYS OR PLATED THEREWITH, PRECIOUS STONES OR SEMI-PRECIOUS STONES, NAMELY, JEWELRY; JEWELRY ARTICLES, NAMELY, FINGER RINGS, BRACELETS MADE OF LEATHER, EARRINGS OF PRECIOUS METAL, CUFF LINKS, BRACELETS OF PRECIOUS METAL, NECKLACES OF PRECIOUS METAL, PENDANTS OF PRECIOUS METAL, NECKLACES MADE OF LEATHER, CASES FOR JEWELRY (U.S. CLS. 2, 27, 28 AND 50).

JENNY PARK, EXAMINING ATTORNEY

CLASS 14—(Continued).

SN 85-271,152. JR DE BELLARD FINE JEWELRY INC, MIAMI, FL. FILED 3-18-2011.



THE MARK CONSISTS OF STYLIZED DESIGN OF FOUR HEARTS THAT ARE JOINED TOGETHER TO FORM A CROSS.

FOR ARTICLES MADE OF PRECIOUS METALS, AND THEIR ALLOYS OR PLATED THEREWITH, PRECIOUS STONES OR SEMI-PRECIOUS STONES, NAMELY, JEWELRY; JEWELRY ARTICLES, NAMELY, FINGER RINGS, BRACELETS MADE OF LEATHER, EARRINGS OF PRECIOUS METAL, CUFF LINKS, BRACELETS OF PRECIOUS METAL, NECKLACES OF PRECIOUS METAL, PENDANTS OF PRECIOUS METAL, NECKLACES MADE OF LEATHER, CASES FOR JEWELRY (U.S. CLS. 2, 27, 28 AND 50).

JENNY PARK, EXAMINING ATTORNEY

CLASS 14—(Continued).

SN 85-273,407. HALCRAFT USA, INC., MT. VERNON, NY. FILED 3-22-2011.



OWNER OF U.S. REG. NOS. 3,182,123 AND 3,928,243. NO CLAIM IS MADE TO THE EXCLUSIVE RIGHT TO USE "BEAD", APART FROM THE MARK AS SHOWN.

THE COLOR(S) RED AND WHITE IS/ARE CLAIMED AS A FEATURE OF THE MARK.

THE MARK CONSISTS OF A RED BACKGROUND WITH A WHITE RECTANGLE HAVING ROUNDED CORNERS AND THE WORD "BEAD" IN WHITE OVER THE WORD "GALLERY" IN WHITE. EXTENDING UPWARDLY FROM THE LEFT SIDE OF THE RECTANGLE IS A FIRST WHITE LINE WHICH RUNS VERTICALLY AND THEN TURNS HORIZONTALLY EXTENDING TO THE RIGHT EDGE OF THE BACKGROUND. EXTENDING IN OPPOSITE DIRECTIONS ALONG THE RIGHT SIDE OF THE RECTANGLE IS A SECOND WHITE LINE WHICH RUNS VERTICALLY DOWNWARD AND THEN TURNS HORIZONTALLY BELOW THE RECTANGLE WITH ONE END EXTENDING TO THE LEFT EDGE OF THE BACKGROUND, AND WHICH RUNS VERTICALLY UPWARD AND THEN TURNS HORIZONTALLY, BELOW THE FIRST LINE, WITH ANOTHER END ALSO EXTENDING TO THE LEFT EDGE OF THE BACKGROUND. A THIRD WHITE LINE RUNS HORIZONTALLY LEFTWARD FROM A POINT ON THE VERTICAL PORTION OF THE SECOND LINE INTERMEDIATE THE RECTANGLE AND THE HORIZONTAL PORTION OF THE SECOND LINE FOR A SHORT DISTANCE AND THEN TURNS UPWARDLY TO RUN VERTICALLY TO A POINT ABOVE THE HORIZONTAL PORTION OF THE FIRST LINE. A SHORT FOURTH WHITE LINE EXTENDS FROM THE RIGHT SIDE OF THE RECTANGLE TO THE RIGHT EDGE OF THE BACKGROUND. THE NAME "HALCRAFT" IN RED APPEARS ON A WHITE BACKGROUND EXTENDING HORIZONTALLY FROM THE VERTICAL PORTION OF THE FIRST LINE BENEATH THE SECOND LINE.

FOR BEADS FOR USE IN THE MANUFACTURE OF JEWELRY; CHAINS FOR USE IN THE MANUFACTURE OF JEWELRY; FINDINGS FOR USE IN THE MANUFACTURE OF JEWELRY (U.S. CLS. 2, 27, 28 AND 50).

FIRST USE 5-3-2006; IN COMMERCE 5-3-2006.

GRETTA YAO, EXAMINING ATTORNEY

SN 85-273,063. DAWSON HERITAGE FURNITURE COMPANY, INC., WEBB CITY, MO. FILED 3-22-2011.

Gunfather Clock

THE MARK CONSISTS OF STANDARD CHARACTERS WITHOUT CLAIM TO ANY PARTICULAR FONT, STYLE, SIZE, OR COLOR.

NO CLAIM IS MADE TO THE EXCLUSIVE RIGHT TO USE "CLOCK", APART FROM THE MARK AS SHOWN.

FOR CLOCKS (U.S. CLS. 2, 27, 28 AND 50).

FIRST USE 3-21-2011; IN COMMERCE 3-21-2011.

GILBERT SWIFT, EXAMINING ATTORNEY

CLASS 14—(Continued).

SN 85-273,444. HALCRAFT USA, INC., MT. VERNON, NY.
FILED 3-22-2011.

**CLASS 14—(Continued).**

SN 85-273,501. HALCRAFT USA, INC., MT. VERNON, NY.
FILED 3-22-2011.



OWNER OF U.S. REG. NOS. 2,992,290, 3,182,123 AND 3,928,243.

NO CLAIM IS MADE TO THE EXCLUSIVE RIGHT TO USE "BEAD", APART FROM THE MARK AS SHOWN.

THE COLOR(S) GREEN AND WHITE IS/ARE CLAIMED AS A FEATURE OF THE MARK.

THE MARK CONSISTS OF A GREEN BACKGROUND WITH A WHITE RECTANGLE HAVING ROUNDED CORNERS AND THE WORD "BEAD" IN WHITE OVER THE WORD "GALLERY" IN WHITE. EXTENDING UPWARDLY FROM THE LEFT SIDE OF THE RECTANGLE IS A FIRST WHITE LINE WHICH RUNS VERTICALLY AND THEN TURNS HORIZONTALLY EXTENDING TO THE RIGHT EDGE OF THE BACKGROUND. EXTENDING IN OPPOSITE DIRECTIONS ALONG THE RIGHT SIDE OF THE RECTANGLE IS A SECOND WHITE LINE WHICH RUNS VERTICALLY DOWNWARD AND THEN TURNS HORIZONTALLY BELOW THE RECTANGLE WITH ONE END EXTENDING TO THE LEFT EDGE OF THE BACKGROUND, AND WHICH RUNS VERTICALLY UPWARD AND THEN TURNS HORIZONTALLY, BELOW THE FIRST LINE, WITH ANOTHER END ALSO EXTENDING TO THE LEFT EDGE OF THE BACKGROUND. A THIRD WHITE LINE RUNS HORIZONTALLY LEFTWARD FROM A POINT ON THE VERTICAL PORTION OF THE SECOND LINE INTERMEDIATE THE RECTANGLE AND THE HORIZONTAL PORTION OF THE SECOND LINE FOR A SHORT DISTANCE AND THEN TURNS UPWARDLY TO RUN VERTICALLY TO A POINT ABOVE THE HORIZONTAL PORTION OF THE FIRST LINE. A SHORT FOURTH WHITE LINE EXTENDS FROM THE RIGHT SIDE OF THE RECTANGLE TO THE RIGHT EDGE OF THE BACKGROUND. THE NAME "HALCRAFT" IN GREEN APPEARS ON A WHITE BACKGROUND EXTENDING HORIZONTALLY FROM THE VERTICAL PORTION OF THE FIRST LINE BENEATH THE SECOND LINE.

FOR BEADS FOR USE IN THE MANUFACTURE OF JEWELRY; CHAINS FOR USE IN THE MANUFACTURE OF JEWELRY; FINDINGS FOR USE IN THE MANUFACTURE OF JEWELRY (U.S. CLS. 2, 27, 28 AND 50).

FIRST USE 5-3-2006; IN COMMERCE 5-3-2006.

GRETTA YAO, EXAMINING ATTORNEY

OWNER OF U.S. REG. NOS. 2,992,290, 3,182,123 AND 3,928,243.

NO CLAIM IS MADE TO THE EXCLUSIVE RIGHT TO USE "BEAD", APART FROM THE MARK AS SHOWN.

THE COLOR(S) BROWN AND WHITE IS/ARE CLAIMED AS A FEATURE OF THE MARK.

THE MARK CONSISTS OF A BROWN BACKGROUND WITH A WHITE RECTANGLE HAVING ROUNDED CORNERS AND THE WORD "BEAD" IN WHITE OVER THE WORD "GALLERY" IN WHITE. EXTENDING UPWARDLY FROM THE LEFT SIDE OF THE RECTANGLE IS A FIRST WHITE LINE WHICH RUNS VERTICALLY AND THEN TURNS HORIZONTALLY EXTENDING TO THE RIGHT EDGE OF THE BACKGROUND. EXTENDING IN OPPOSITE DIRECTIONS ALONG THE RIGHT SIDE OF THE RECTANGLE IS A SECOND WHITE LINE WHICH RUNS VERTICALLY DOWNWARD AND THEN TURNS HORIZONTALLY BELOW THE RECTANGLE WITH ONE END EXTENDING TO THE LEFT EDGE OF THE BACKGROUND, AND WHICH RUNS VERTICALLY UPWARD AND THEN TURNS HORIZONTALLY, BELOW THE FIRST LINE, WITH ANOTHER END ALSO EXTENDING TO THE LEFT EDGE OF THE BACKGROUND. A THIRD WHITE LINE RUNS HORIZONTALLY LEFTWARD FROM A POINT ON THE VERTICAL PORTION OF THE SECOND LINE INTERMEDIATE THE RECTANGLE AND THE HORIZONTAL PORTION OF THE SECOND LINE FOR A SHORT DISTANCE AND THEN TURNS UPWARDLY TO RUN VERTICALLY TO A POINT ABOVE THE HORIZONTAL PORTION OF THE FIRST LINE. A SHORT FOURTH WHITE LINE EXTENDS FROM THE RIGHT SIDE OF THE RECTANGLE TO THE RIGHT EDGE OF THE BACKGROUND. THE NAME "HALCRAFT" IN BROWN APPEARS ON A WHITE BACKGROUND EXTENDING HORIZONTALLY FROM THE VERTICAL PORTION OF THE FIRST LINE BENEATH THE SECOND LINE.

FOR BEADS FOR USE IN THE MANUFACTURE OF JEWELRY; CHAINS FOR USE IN THE MANUFACTURE OF JEWELRY; FINDINGS FOR USE IN THE MANUFACTURE OF JEWELRY (U.S. CLS. 2, 27, 28 AND 50).

FIRST USE 0-0-2008; IN COMMERCE 0-0-2008.

GRETTA YAO, EXAMINING ATTORNEY

CLASS 14—(Continued).

SN 85-273,522. HALCRAFT USA, INC., MT. VERNON, NY.
FILED 3-22-2011.



CLASS 14—(Continued).

SN 85-273,570. HALCRAFT USA, INC., MT. VERNON, NY.
FILED 3-22-2011.



OWNER OF U.S. REG. NOS. 2,992,290, 3,182,123 AND 3,928,243.

NO CLAIM IS MADE TO THE EXCLUSIVE RIGHT TO USE "BEAD", APART FROM THE MARK AS SHOWN.

THE COLOR(S) CYAN AND WHITE IS/ARE CLAIMED AS A FEATURE OF THE MARK.

THE MARK CONSISTS OF A CYAN BACKGROUND WITH A WHITE RECTANGLE HAVING ROUNDED CORNERS AND THE WORD "BEAD" IN WHITE OVER THE WORD "GALLERY" IN WHITE. EXTENDING UPWARDLY FROM THE LEFT SIDE OF THE RECTANGLE IS A FIRST WHITE LINE WHICH RUNS VERTICALLY AND THEN TURNS HORIZONTALLY EXTENDING TO THE RIGHT EDGE OF THE BACKGROUND. EXTENDING IN OPPOSITE DIRECTIONS ALONG THE RIGHT SIDE OF THE RECTANGLE IS A SECOND WHITE LINE WHICH RUNS VERTICALLY DOWNWARD AND THEN TURNS HORIZONTALLY BELOW THE RECTANGLE WITH ONE END EXTENDING TO THE LEFT EDGE OF THE BACKGROUND, AND WHICH RUNS VERTICALLY UPWARD AND THEN TURNS HORIZONTALLY, BELOW THE FIRST LINE, WITH ANOTHER END ALSO EXTENDING TO THE LEFT EDGE OF THE BACKGROUND. A THIRD WHITE LINE RUNS HORIZONTALLY LEFTWARD FROM A POINT ON THE VERTICAL PORTION OF THE SECOND LINE INTERMEDIATE THE RECTANGLE AND THE HORIZONTAL PORTION OF THE SECOND LINE FOR A SHORT DISTANCE AND THEN TURNS UPWARDLY TO RUN VERTICALLY TO A POINT ABOVE THE HORIZONTAL PORTION OF THE FIRST LINE. A SHORT FOURTH WHITE LINE EXTENDS FROM THE RIGHT SIDE OF THE RECTANGLE TO THE RIGHT EDGE OF THE BACKGROUND. THE NAME "HALCRAFT" IN CYAN APPEARS ON A WHITE BACKGROUND EXTENDING HORIZONTALLY FROM THE VERTICAL PORTION OF THE FIRST LINE BENEATH THE SECOND LINE.

FOR BEADS FOR USE IN THE MANUFACTURE OF JEWELRY; CHAINS FOR USE IN THE MANUFACTURE OF JEWELRY; FINDINGS FOR USE IN THE MANUFACTURE OF JEWELRY (U.S. CLS. 2, 27, 28 AND 50).

FIRST USE 0-0-2009; IN COMMERCE 0-0-2009.

GRETTA YAO, EXAMINING ATTORNEY

OWNER OF U.S. REG. NOS. 2,992,290, 3,182,123 AND 3,928,243.

NO CLAIM IS MADE TO THE EXCLUSIVE RIGHT TO USE "BEAD", APART FROM THE MARK AS SHOWN.

THE COLOR(S) BLUE AND WHITE IS/ARE CLAIMED AS A FEATURE OF THE MARK.

THE MARK CONSISTS OF A BLUE BACKGROUND WITH A WHITE RECTANGLE HAVING ROUNDED CORNERS AND THE WORD "BEAD" IN WHITE OVER THE WORD "GALLERY" IN WHITE. EXTENDING UPWARDLY FROM THE LEFT SIDE OF THE RECTANGLE IS A FIRST WHITE LINE WHICH RUNS VERTICALLY AND THEN TURNS HORIZONTALLY EXTENDING TO THE RIGHT EDGE OF THE BACKGROUND. EXTENDING IN OPPOSITE DIRECTIONS ALONG THE RIGHT SIDE OF THE RECTANGLE IS A SECOND WHITE LINE WHICH RUNS VERTICALLY DOWNWARD AND THEN TURNS HORIZONTALLY BELOW THE RECTANGLE WITH ONE END EXTENDING TO THE LEFT EDGE OF THE BACKGROUND, AND WHICH RUNS VERTICALLY UPWARD AND THEN TURNS HORIZONTALLY, BELOW THE FIRST LINE, WITH ANOTHER END ALSO EXTENDING TO THE LEFT EDGE OF THE BACKGROUND. A THIRD WHITE LINE RUNS HORIZONTALLY LEFTWARD FROM A POINT ON THE VERTICAL PORTION OF THE SECOND LINE INTERMEDIATE THE RECTANGLE AND THE HORIZONTAL PORTION OF THE SECOND LINE FOR A SHORT DISTANCE AND THEN TURNS UPWARDLY TO RUN VERTICALLY TO A POINT ABOVE THE HORIZONTAL PORTION OF THE FIRST LINE. A SHORT FOURTH WHITE LINE EXTENDS FROM THE RIGHT SIDE OF THE RECTANGLE TO THE RIGHT EDGE OF THE BACKGROUND. THE NAME "HALCRAFT" IN BLUE APPEARS ON A WHITE BACKGROUND EXTENDING HORIZONTALLY FROM THE VERTICAL PORTION OF THE FIRST LINE BENEATH THE SECOND LINE.

FOR BEADS FOR USE IN THE MANUFACTURE OF JEWELRY; CHAINS FOR USE IN THE MANUFACTURE OF JEWELRY; FINDINGS FOR USE IN THE MANUFACTURE OF JEWELRY (U.S. CLS. 2, 27, 28 AND 50).

FIRST USE 0-0-2009; IN COMMERCE 0-0-2009.

GRETTA YAO, EXAMINING ATTORNEY

CLASS 14—(Continued).

SN 85-273,626. HALCRAFT USA, INC., MT. VERNON, NY. FILED 3-22-2011.



OWNER OF U.S. REG. NOS. 3,182,123 AND 3,928,243.
NO CLAIM IS MADE TO THE EXCLUSIVE RIGHT TO USE "BEAD", APART FROM THE MARK AS SHOWN.
THE COLOR(S) DARK GRAY, LIGHT GRAY, AND BLACK IS/ARE CLAIMED AS A FEATURE OF THE MARK.
THE MARK CONSISTS OF THE WORDS "BEAD GALLERY" IN BLACK LOWER CASE PRINT ABOVE AN OUTLINE OF A RECTANGLE WITH A DARK GRAY BORDER, ALL ON A LIGHTER GRAY BACKGROUND. THE RECTANGLE HAS A DARK GRAY SHADOW ALONG ITS RIGHT AND LOWER SIDES.
FOR PENDANTS (U.S. CLS. 2, 27, 28 AND 50).
FIRST USE 0-0-2009; IN COMMERCE 0-0-2009.
GRETTA YAO, EXAMINING ATTORNEY

SN 85-274,156. STELLA CHOW, ATLANTA, GA. FILED 3-23-2011.

JADE OF YESTERYEAR

THE MARK CONSISTS OF STANDARD CHARACTERS WITHOUT CLAIM TO ANY PARTICULAR FONT, STYLE, SIZE, OR COLOR.
NO CLAIM IS MADE TO THE EXCLUSIVE RIGHT TO USE "JADE", APART FROM THE MARK AS SHOWN.
FOR JEWELRY (U.S. CLS. 2, 27, 28 AND 50).
FIRST USE 1-31-2011; IN COMMERCE 1-31-2011.
KAPIL BHANOT, EXAMINING ATTORNEY

CLASS 14—(Continued).

SN 85-276,029. BDRSCO, INC., WILMINGTON, DE. FILED 3-24-2011.

WURL

THE MARK CONSISTS OF STANDARD CHARACTERS WITHOUT CLAIM TO ANY PARTICULAR FONT, STYLE, SIZE, OR COLOR.
OWNER OF U.S. REG. NOS. 3,386,143 AND 3,742,838.
FOR JEWELRY (U.S. CLS. 2, 27, 28 AND 50).
MATTHEW MCDOWELL, EXAMINING ATTORNEY

SN 85-277,993. WINTER, AGNES-NICOLE, BEVERLY HILLS, CA. FILED 3-26-2011.



THE NAME "AGNES-NICOLE" IDENTIFIES A LIVING INDIVIDUAL WHOSE CONSENT IS OF RECORD.
THE MARK CONSISTS OF A FIVE-SIDED DIAMOND ENCOMPASSING THE LETTERS "AN". ALSO, THE NAME "AGNES-NICOLE" APPEARS PARALLEL TO THE BOTTOM LEFT EDGE OF THE DIAMOND AND IS NEARLY THE LENGTH OF THAT SIDE.
FOR BEADS FOR USE IN THE MANUFACTURE OF JEWELRY; BODY JEWELRY; BRACELETS; BRACELETS; BRACELETS MADE OF NON-PRECIOUS METALS AND NON-PRECIOUS METALS COATED WITH PRECIOUS METALS; BRACELETS OF PRECIOUS METAL; BROACHES; BRONZE JEWELRY; BROOCHES; CAMEOS; CHARMS; CHARMS FOR COLLAR JEWELRY AND BRACELET; COSTUME JEWELRY; DIAMOND JEWELRY; DRESS WATCHES; GEMSTONE JEWELRY; GOLD THREAD JEWELRY; HAIR JEWELRY IN THE NATURE OF JEWELRY FOR USE IN THE HAIR; IDENTIFICATION BRACELETS; INEXPENSIVE NON-JEWELRY WATCHES; JEWELRY CASES; JEWELRY; JEWELRY AND IMITATION JEWELRY; JEWELRY BOXES; JEWELRY BOXES NOT OF METAL; JEWELRY BOXES OF METAL; JEWELRY BROOCHES; JEWELRY CASES; JEWELRY CASES NOT OF PRECIOUS METAL; JEWELRY CASES OF PRECIOUS METAL; JEWELRY CASKETS; JEWELRY CHAINS; JEWELRY FOR ATTACHMENT TO CLOTHING; JEWELRY FOR THE HEAD; JEWELRY IN THE NATURE OF ARMBANDS; JEWELRY ORGANIZERS; JEWELRY PINS FOR USE ON HATS; JEWELRY RING HOLDERS; JEWELRY STICK-

CLASS 14—(Continued).

PINS; JEWELRY THAT INCORPORATES TECHNOLOGY FOR REBALANCING THE HUMAN ENERGY FIELD; JEWELRY TO BE AFFIXED TO BIKINIS; JEWELRY WATCHES; JEWELRY, NAMELY, AMULETS; JEWELRY, NAMELY, ANKLETS; JEWELRY, NAMELY, ARM CUFFS; JEWELRY, NAMELY, CROSSES; JEWELRY, NAMELY, DOG TAGS FOR WEAR BY HUMANS FOR DECORATIVE PURPOSES; JEWELRY, NAMELY, MAGNETIC NECKLACES; JEWELRY, NAMELY, STONE PENDANTS; LAPEL PINS; LEATHER JEWELRY AND ACCESSORY BOXES; METAL WIRE FOR USE IN THE MAKING OF JEWELRY, NAMELY, JEWELRY CABLE; PET JEWELRY; PINS BEING JEWELRY; PLASTIC BRACELETS IN THE NATURE OF JEWELRY; PRECIOUS AND SEMI-PRECIOUS CRYSTAL STONES AND BEADS FOR USE IN JEWELRY; RINGS; RUBBER OR SILICON WRISTBANDS IN THE NATURE OF A BRACELET; STAINLESS STEEL JEWELRY BRACELETS; WATCHES AND JEWELRY; WATCHES, CLOCKS, JEWELRY AND IMITATION JEWELRY; WOMEN'S JEWELRY; WOMEN'S WATCHES (U.S. CLS. 2, 27, 28 AND 50).

DAWN FELDMAN, EXAMINING ATTORNEY

SN 85-283,101. MICHELLE LORRAINNE LLC, DBA GEN-X, DENVER, NJ. FILED 3-31-2011.



THE MARK CONSISTS OF THE STYLIZED WORDING "GEN-X" APPEARING BELOW THE DESIGN OF A FOOT-PRINT SURROUNDED BY THE DESIGN OF A SPADE. FOR WRISTWATCHES (U.S. CLS. 2, 27, 28 AND 50).

MICHAEL TANNER, EXAMINING ATTORNEY

SN 85-284,779. E-MARKETINGUSA, INC., EAST WENATCHEE, WA. FILED 4-3-2011.

Gestalt Couture

THE MARK CONSISTS OF STANDARD CHARACTERS WITHOUT CLAIM TO ANY PARTICULAR FONT, STYLE, SIZE, OR COLOR.

OWNER OF U.S. REG. NO. 3,807,803.

NO CLAIM IS MADE TO THE EXCLUSIVE RIGHT TO USE "COUTURE", APART FROM THE MARK AS SHOWN.

FOR JEWELRY; WATCHES (U.S. CLS. 2, 27, 28 AND 50).

JANET LEE, EXAMINING ATTORNEY

CLASS 14—(Continued).

SN 85-288,759. MICHAEL KORS, L.L.C., NEW YORK, NY. FILED 4-7-2011.

MICHAEL KORS

THE MARK CONSISTS OF STANDARD CHARACTERS WITHOUT CLAIM TO ANY PARTICULAR FONT, STYLE, SIZE, OR COLOR.

OWNER OF U.S. REG. NOS. 2,520,757, 3,535,310 AND OTHERS.

THE NAME MICHAEL KORS IDENTIFIES A LIVING INDIVIDUAL WHOSE CONSENT IS OF RECORD.

FOR JEWELRY (U.S. CLS. 2, 27, 28 AND 50).

FIRST USE 10-1-2005; IN COMMERCE 10-1-2005.

TARA PATE, EXAMINING ATTORNEY

SN 85-288,858. MICHAEL KORS, L.L.C., NEW YORK, NY. FILED 4-7-2011.

MICHAEL MICHAEL KORS

THE MARK CONSISTS OF STANDARD CHARACTERS WITHOUT CLAIM TO ANY PARTICULAR FONT, STYLE, SIZE, OR COLOR.

OWNER OF U.S. REG. NOS. 3,080,631, 3,535,310 AND OTHERS.

THE NAME MICHAEL KORS IDENTIFIES A LIVING INDIVIDUAL WHOSE CONSENT IS OF RECORD.

FOR JEWELRY AND WATCHES (U.S. CLS. 2, 27, 28 AND 50).

FIRST USE 10-1-2010; IN COMMERCE 10-1-2010.

TARA PATE, EXAMINING ATTORNEY

SN 85-291,557. INSPIRED JEWELRY, INC, CEDAR RAPIDS, IA. FILED 4-11-2011.

neobail

THE MARK CONSISTS OF STANDARD CHARACTERS WITHOUT CLAIM TO ANY PARTICULAR FONT, STYLE, SIZE, OR COLOR.

FOR BRACELETS; CHARMS; CHARMS FOR COLLAR JEWELRY AND BRACELET; JEWELRY FINDINGS; JEWELRY FOR ATTACHMENT TO CLOTHING; JEWELRY, NAMELY, AMULETS; JEWELRY, NAMELY, CROSSES; JEWELRY, NAMELY, MAGNETIC NECKLACES; JEWELRY, NAMELY, MAGNETIC PENDANTS; WOMEN'S JEWELRY (U.S. CLS. 2, 27, 28 AND 50).

ANNE E. GUSTASON, EXAMINING ATTORNEY

CLASS 14—(Continued).

SN 85-292,181. GENNCO INTERNATIONAL INC., WHEELING, IL. FILED 4-11-2011.

HAMLIN AQUA MARITIME

THE MARK CONSISTS OF STANDARD CHARACTERS WITHOUT CLAIM TO ANY PARTICULAR FONT, STYLE, SIZE, OR COLOR.

NO CLAIM IS MADE TO THE EXCLUSIVE RIGHT TO USE "AQUA MARITIME", APART FROM THE MARK AS SHOWN.

FOR CLOCKS AND WATCHES; PARTS FOR WATCHES; WATCH BOXES (U.S. CLS. 2, 27, 28 AND 50).
FIRST USE 3-1-2011; IN COMMERCE 4-1-2011.
JORDAN BAKER, EXAMINING ATTORNEY

SN 85-292,214. INSPIRED JEWELRY, INC., CEDAR RAPIDS, IA. FILED 4-11-2011.

My American Soldier

THE MARK CONSISTS OF STANDARD CHARACTERS WITHOUT CLAIM TO ANY PARTICULAR FONT, STYLE, SIZE, OR COLOR.

FOR BRACELETS; CHARMS; CHARMS FOR COLLAR JEWELRY AND BRACELET; COSTUME JEWELRY; JEWELRY; JEWELRY BROOCHES; JEWELRY FOR ATTACHMENT TO CLOTHING; JEWELRY, NAMELY, AMULETS; JEWELRY, NAMELY, MAGNETIC NECKLACES; JEWELRY, NAMELY, MAGNETIC PENDANTS (U.S. CLS. 2, 27, 28 AND 50).

JUSTINE D. PARKER, EXAMINING ATTORNEY

SN 85-292,274. REBECCA MICHELLE DOWNIN, DAVENPORT, FL. FILED 4-11-2011.

THE MARK CONSISTS OF THE WORD SCULPTURINGS IN STYLIZED FONT.

FOR JEWELRY, NAMELY, RINGS (U.S. CLS. 2, 27, 28 AND 50).

ANNE MADDEN, EXAMINING ATTORNEY

CLASS 14—(Continued).

SN 85-292,603. DONROS, LLC, HOUSTON, TX. FILED 4-12-2011.

KAROVADO

THE MARK CONSISTS OF STANDARD CHARACTERS WITHOUT CLAIM TO ANY PARTICULAR FONT, STYLE, SIZE, OR COLOR.

THE WORDING "KAROVADO" HAS NO MEANING IN A FOREIGN LANGUAGE.

FOR JEWELRY (U.S. CLS. 2, 27, 28 AND 50).

AMY HELLA, EXAMINING ATTORNEY

SN 85-292,628. SHIELER TRADING CORP., NEW YORK, NY. FILED 4-12-2011.

DAVID [®] RAPHAEL

THE NAME(S), PORTRAIT(S), AND/OR SIGNATURE(S) SHOWN IN THE MARK IDENTIFIES A LIVING INDIVIDUAL, WHOSE CONSENT(S) TO REGISTER IS MADE OF RECORD.

THE MARK CONSISTS OF THE WORDS "DAVID RAPHAEL" WITH THE LETTERS "D & R" INTERTWINED IN BETWEEN THEM.

FOR JEWELRY, NAMELY, NECKLACES, RINGS, EARRINGS, BRACELETS, PENDANTS AND CUFF LINKS MADE OF GOLD, SILVER, DIAMONDS, PRECIOUS STONES AND SEMI-PRECIOUS STONES; WATCHES (U.S. CLS. 2, 27, 28 AND 50).

ELLEN B. AWRICH, EXAMINING ATTORNEY

SN 85-293,015. KALIN MANCHEV, HENDERSON, NV. FILED 4-12-2011.

KALIN

THE MARK CONSISTS OF STANDARD CHARACTERS WITHOUT CLAIM TO ANY PARTICULAR FONT, STYLE, SIZE, OR COLOR.

THE NAME(S), PORTRAIT(S), AND/OR SIGNATURE(S) SHOWN IN THE MARK IDENTIFIES APPLICANT, WHOSE CONSENT(S) TO REGISTER IS MADE OF RECORD.

FOR JEWELRY (U.S. CLS. 2, 27, 28 AND 50).

GRETTA YAO, EXAMINING ATTORNEY

CLASS 14—(Continued).

SN 85-293,072. KALIN MANCHEV, HENDERSON, NV.
FILED 4-12-2011.

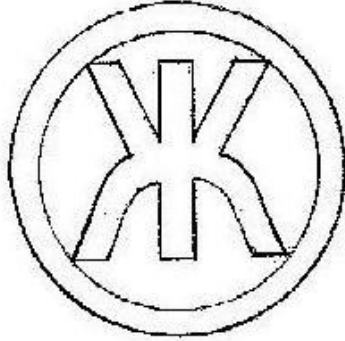

THE MARK CONSISTS OF THE CYRILLIC LETTER 'ZHE'
SUPERIMPOSED UPON A TORIC RING.
FOR JEWELRY (U.S. CLS. 2, 27, 28 AND 50).
GRETTA YAO, EXAMINING ATTORNEY

SN 85-293,256. ROWELL, MATTHEW, CEDAR HILL, TX.
FILED 4-12-2011.

WWTFD

THE MARK CONSISTS OF STANDARD CHARACTERS
WITHOUT CLAIM TO ANY PARTICULAR FONT, STYLE,
SIZE, OR COLOR.

FOR NECKLACES; RUBBER OR SILICON WRIST-
BANDS IN THE NATURE OF A BRACELET (U.S. CLS.
2, 27, 28 AND 50).

DAVID COLLIER, EXAMINING ATTORNEY

SN 85-293,598. AFFIRMATION LIMITED, LONDON, UNI-
TED KINGDOM, FILED 4-13-2011.

OMBANDS

THE MARK CONSISTS OF STANDARD CHARACTERS
WITHOUT CLAIM TO ANY PARTICULAR FONT, STYLE,
SIZE, OR COLOR.

FOR AMULETS; ANKLE BRACELETS; BADGES OF
PRECIOUS METAL; BANGLE BRACELETS; BANGLES;
BEADS FOR USE IN THE MANUFACTURE OF JEW-
ELRY; BRACELETS; BRACELETS; BRACELETS AND
JEWELRY FEATURING ELECTRONIC CHIPS FOR AT-
TRACTING ENERGY TO THE BODY WHEREIN THE
ELECTRONIC CHIPS INCREASE IN POWER IN THE
PRESENCE OF ELECTROMAGNETIC FIELDS, FOR THE
PURPOSE OF RE-BALANCING THE HUMAN ENERGY
FIELD; BRACELETS MADE OF ANY MATERIAL; BRACE-
LETS OF PRECIOUS METAL; BROACHES; BRONZE
JEWELRY; BROOCHES; CAMEOS; CASES FOR CLOCK
AND WATCH-MAKING; CASES FOR WATCHES AND

CLASS 14—(Continued).

CLOCKS; CASKETS FOR CLOCKS AND JEWELS;
CHARITY BRACELETS; CHARMS; CHARMS FOR COL-
LAR JEWELRY AND BRACELET; CHARMS IN PRE-
CIOUS METALS OR COATED THEREWITH;
CHRONOGRAPHS AS WATCHES; CHRONOGRAPHS
FOR USE AS WATCHES; CHRONOMETRIC INSTRU-
MENTS AND WATCH MOVEMENTS; CLOCK AND
WATCH HANDS; CLOCKS AND WATCHES; CLOCKS
AND WATCHES FOR PIGEON-FANCIERS; COMPLI-
CATION WATCHES; COSTUME JEWELRY; CUFF LINKS
OF PRECIOUS METAL; DIALS FOR CLOCK-AND-
WATCH-MAKING; DIAMOND JEWELRY; DIVING
WATCHES; DRESS WATCHES; EQUESTRIAN
WATCHES; FANCY KEYRINGS OF PRECIOUS MET-
ALS; GEMSTONE JEWELRY; GOLD THREAD JEWEL-
RY; HAIR JEWELRY IN THE NATURE OF JEWELRY
FOR USE IN THE HAIR; HAT ORNAMENTS OF PRE-
CIOUS METAL; IDENTIFICATION BRACELETS; IMITA-
TION JEWELLERY; INEXPENSIVE NON-JEWELRY
WATCHES; INGOTS OF PRECIOUS METAL; INSIGNIAS
OF PRECIOUS METAL; JADE; JEWEL CASES OF PRE-
CIOUS METAL; JEWEL CHAINS; JEWEL PENDANTS;
JEWELLERY; JEWELLERY AND IMITATION JEWEL-
LERY; JEWELLERY AND PRECIOUS STONES; JEWEL-
LERY AND WATCHES; JEWELLERY CASES;
JEWELLERY CASES OF PRECIOUS METAL; JEWEL-
LERY CHAIN OF PRECIOUS METAL FOR BRACELETS;
JEWELLERY CHAINS; JEWELLERY PLATED WITH
PRECIOUS METALS; JEWELLERY, CLOCKS AND
WATCHES; JEWELLERY, INCLUDING IMITATION
JEWELLERY AND PLASTIC JEWELLERY; JEWELRY;
JEWELRY AND IMITATION JEWELRY; JEWELRY AR-
MOIRES; JEWELRY BOXES; JEWELRY BOXES NOT OF
METAL; JEWELRY BOXES OF METAL; JEWELRY
BOXES OF PRECIOUS METAL; JEWELRY BROOCHES;
JEWELRY CASES; JEWELRY CASES NOT OF PRECIOUS
METAL; JEWELRY CASES OF PRECIOUS METAL;
JEWELRY CASKETS; JEWELRY CASKETS OF PRE-
CIOUS METAL; JEWELRY CHAINS; JEWELRY DISHES;
JEWELRY FINDINGS; JEWELRY FOR ATTACHMENT
TO CLOTHING; JEWELRY FOR THE HEAD; JEWELRY
IN THE NATURE OF ARMBANDS; JEWELRY INCOR-
PORATING A COMPUTER STORAGE DEVICE CON-
TAINING MEDICAL INFORMATION FOR MEDICAL
ALERT PURPOSES; JEWELRY MAKING KITS; JEWEL-
RY ORGANIZERS; JEWELRY PINS FOR USE ON
HATS; JEWELRY RING HOLDERS; JEWELRY STICK-
PINS; JEWELRY THAT FITS OVER THE FRONT TEETH;
JEWELRY THAT INCORPORATES TECHNOLOGY FOR
REBALANCING THE HUMAN ENERGY FIELD; JEWEL-
RY TO BE AFFIXED TO BIKINIS; JEWELRY
WATCHES; JEWELRY, NAMELY, AMULETS; JEWELRY,
NAMELY, ANKLETS; JEWELRY, NAMELY, ARM
CUFFS; JEWELRY, NAMELY, BRACELETS, WRIST-
BANDS AND NECKLACES THAT ALSO PROVIDES
NOTIFICATION TO THE WEARER OF A PENDING
MEDICAL RELATED TASK; JEWELRY, NAMELY,
CROSSES; JEWELRY, NAMELY, DOG TAGS FOR WEAR
BY HUMANS FOR DECORATIVE PURPOSES; JEWEL-
RY, NAMELY, MAGNETIC NECKLACES; JEWELRY,
NAMELY, MAGNETIC PENDANTS; JEWELRY,
NAMELY, PRECIOUS METAL PLATED REAL LEAVES
AND FLOWERS; JEWELRY, NAMELY, STONE PEN-
DANTS; JEWELS; KEY CHAINS AS JEWELLERY; KEY
CHAINS OF PRECIOUS METAL; KEY HOLDERS OF
PRECIOUS METALS; KEY RINGS OF PRECIOUS METAL;
KEY RINGS OF PRECIOUS METALS; LAPEL PINS;
LEATHER JEWELRY AND ACCESSORY BOXES; ME-
CHANICAL AND AUTOMATIC WATCHES; METAL
WIRE FOR USE IN THE MAKING OF JEWELRY,
NAMELY, JEWELRY CABLE; NECKLACES; NYLON
ANKLE BRACELETS; NYLON BRACELETS; ORNA-
MENTAL PINS MADE OF PRECIOUS METAL; ORNA-
MENTS OF PRECIOUS METAL; PARTS FOR WATCHES;
PEARLS; PET JEWELRY; PINS BEING JEWELRY; PLAS-
TIC BRACELETS IN THE NATURE OF JEWELRY;
POCKET WATCHES; PRECIOUS AND SEMI-PRECIOUS
CRYSTAL STONES AND BEADS FOR USE IN JEWEL-
RY; PRECIOUS AND SEMI-PRECIOUS GEMS; PRE-
CIOUS AND SEMI-PRECIOUS MINERALS; PRECIOUS
AND SEMI-PRECIOUS STONES; PRECIOUS GEM-
STONES; PRECIOUS JEWELS; PRECIOUS STONES
AND WATCHES; REAL AND IMITATION JEWELLERY;
RINGS; RINGS BEING JEWELRY; RUBBER OR SILI-
CON WRISTBANDS IN THE NATURE OF A BRACELET;
SLAP BRACELETS; SLAPBAND BRACELETS; SMALL
JEWELLERY BOXES OF PRECIOUS METALS; SPORTS

CLASS 14—(Continued).

WATCHES; STAINLESS STEEL JEWELRY BRACELETS; STOP WATCHES; WATCH AND CLOCK SPRINGS; WATCH BANDS; WATCH BANDS AND STRAPS; WATCH BOXES; WATCH BRACELETS; WATCH CASES; WATCH CHAINS; WATCH CLASPS; WATCH CROWNS; WATCH FACES; WATCH FOBS; WATCH GLASSES; WATCH MOVEMENTS; WATCH PARTS; WATCH STRAPS; WATCH STRAPS MADE OF METAL OR LEATHER OR PLASTIC; WATCH WINDERS; WATCH WINDING BUTTONS; WATCHES; WATCHES AND CLOCKS; WATCHES AND JEWELLERY; WATCHES AND JEWELRY; WATCHES AND STRAPS FOR WATCHES; WATCHES CONTAINING A GAME FUNCTION; WATCHES CONTAINING AN ELECTRONIC GAME FUNCTION; WATCHES FOR OUTDOOR USE; WATCHES FOR SPORTING USE; WATCHES MADE OF PRECIOUS METALS OR COATED THEREWITH; WATCHES, CLOCKS; WATCHES, CLOCKS, JEWELLERY AND IMITATION JEWELLERY; WATCHES, CLOCKS, JEWELRY AND IMITATION JEWELRY; WOMEN'S JEWELRY; WOMEN'S WATCHES; WOODEN JEWELLERY BOXES; WRIST WATCHES (U.S. CLS. 2, 27, 28 AND 50).

RONALD AIKENS, EXAMINING ATTORNEY

SN 85-294,936. FABRIKANT TARA INTERNATIONAL, LLC, NEW YORK, NY. FILED 4-14-2011.

SYMPHONY OF LOVE

THE MARK CONSISTS OF STANDARD CHARACTERS WITHOUT CLAIM TO ANY PARTICULAR FONT, STYLE, SIZE, OR COLOR.
FOR JEWELRY (U.S. CLS. 2, 27, 28 AND 50).
DAVID H. STINE, EXAMINING ATTORNEY

SN 85-295,258. TOSYALI INTERNATIONAL INC., TUSCALOOSA, AL. FILED 4-14-2011.

SIVOLD

THE MARK CONSISTS OF STANDARD CHARACTERS WITHOUT CLAIM TO ANY PARTICULAR FONT, STYLE, SIZE, OR COLOR.
FOR JEWELRY (U.S. CLS. 2, 27, 28 AND 50).
FIRST USE 1-0-2011; IN COMMERCE 1-0-2011.
CHRISTINA SOBRAL, EXAMINING ATTORNEY

CLASS 14—(Continued).

SN 85-295,647. NEXTTEN STAUER, LLC, BURNSVILLE, MN. FILED 4-14-2011.

BERZELIAN

THE MARK CONSISTS OF STANDARD CHARACTERS WITHOUT CLAIM TO ANY PARTICULAR FONT, STYLE, SIZE, OR COLOR.

FOR JEWELRY; WATCHES (U.S. CLS. 2, 27, 28 AND 50).

PATRICIA EVANKO, EXAMINING ATTORNEY

SN 85-295,659. NEXTTEN STAUER, LLC, BURNSVILLE, MN. FILED 4-14-2011.

DE DUILLIER

THE MARK CONSISTS OF STANDARD CHARACTERS WITHOUT CLAIM TO ANY PARTICULAR FONT, STYLE, SIZE, OR COLOR.

FOR WATCHES (U.S. CLS. 2, 27, 28 AND 50).

PATRICIA EVANKO, EXAMINING ATTORNEY

SN 85-295,751. SERTOP LLC, LAS VEGAS, NV. FILED 4-14-2011.

Get A Grip 

THE MARK CONSISTS OF THE STYLIZED TEXT "GET A GRIP" WITH A CIRCLE BEHIND A HAND COVERING IT.

FOR RUBBER OR SILICON WRISTBANDS IN THE NATURE OF A BRACELET (U.S. CLS. 2, 27, 28 AND 50).
FIRST USE 3-4-2011; IN COMMERCE 3-14-2011.

SHAILA SETTLES, EXAMINING ATTORNEY

CLASS 14—(Continued).

SN 85-296,906. ANDERSON, MARINA, DBA THE FLYING GODDESS, ENCINO, CA. FILED 4-15-2011.

The Flying Goddess

THE MARK CONSISTS OF STANDARD CHARACTERS WITHOUT CLAIM TO ANY PARTICULAR FONT, STYLE, SIZE, OR COLOR.

FOR BEADS FOR USE IN THE MANUFACTURE OF JEWELRY; BODY JEWELRY; BRACELETS; BROACHES; BROOCHES; CHARMS; CHARMS FOR COLLAR JEWELRY AND BRACELET; COSTUME JEWELRY; DIAMOND JEWELRY; GEMSTONE JEWELRY; HAIR JEWELRY IN THE NATURE OF JEWELRY FOR USE IN THE HAIR; JEWELRY; JEWELRY AND IMITATION JEWELRY; JEWELRY BROOCHES; JEWELRY CHAINS; JEWELRY FOR ATTACHMENT TO CLOTHING; JEWELRY FOR THE HEAD; JEWELRY PINS FOR USE ON HATS; JEWELRY STICKPINS; JEWELRY TO BE AFFIXED TO BIKINIS; JEWELRY, NAMELY, AMULETS; JEWELRY, NAMELY, ANKLETS; JEWELRY, NAMELY, CROSSES; JEWELRY, NAMELY, DOG TAGS FOR WEAR BY HUMANS FOR DECORATIVE PURPOSES; JEWELRY, NAMELY, STONE PENDANTS; LAPEL PINS; PET JEWELRY; PINS BEING JEWELRY; PRECIOUS AND SEMI-PRECIOUS CRYSTAL STONES AND BEADS FOR USE IN JEWELRY; RINGS; RINGS BEING JEWELRY; WOMEN'S JEWELRY (U.S. CLS. 2, 27, 28 AND 50).
FIRST USE 9-23-1997; IN COMMERCE 9-23-1997.
HENRY S. ZAK, EXAMINING ATTORNEY

SN 85-296,974. ROGERS JEWELRY COMPANY, DBA ROGERS JEWELRY CO., MODESTO, CA. FILED 4-15-2011.

fire&ice

OWNER OF U.S. REG. NO. 2,456,648.

THE MARK CONSISTS OF "FIRE&ICE" IN STYLIZED LETTERING WITH A STYLIZED FLAME IN LIEU OF THE DOT OVER THE LETTER "I" IN THE WORD FIRE. FOR GEMSTONES, NAMELY, DIAMONDS (U.S. CLS. 2, 27, 28 AND 50).
FIRST USE 2-6-2010; IN COMMERCE 2-6-2010.
WON TEAK OH, EXAMINING ATTORNEY

SN 85-300,405. BDSRSCO, INC., WILMINGTON, DE. FILED 4-20-2011.

BRIGHTEN THE SEASON

THE MARK CONSISTS OF STANDARD CHARACTERS WITHOUT CLAIM TO ANY PARTICULAR FONT, STYLE, SIZE, OR COLOR.

OWNER OF U.S. REG. NOS. 3,610,533 AND 3,814,908. FOR WATCHES AND JEWELRY (U.S. CLS. 2, 27, 28 AND 50).
MATTHEW MCDOWELL, EXAMINING ATTORNEY

CLASS 14—(Continued).

SN 85-300,799. DIAMOND DIRECT, LLC, NEW YORK, NY. FILED 4-21-2011.

CATARA COBALT

THE MARK CONSISTS OF STANDARD CHARACTERS WITHOUT CLAIM TO ANY PARTICULAR FONT, STYLE, SIZE, OR COLOR.

NO CLAIM IS MADE TO THE EXCLUSIVE RIGHT TO USE "COBALT", APART FROM THE MARK AS SHOWN. FOR JEWELRY (U.S. CLS. 2, 27, 28 AND 50).
JOHN DWYER, EXAMINING ATTORNEY

SN 85-301,319. FINDINGS INCORPORATED, KEENE, NH. FILED 4-21-2011.

QUICK LOCK

THE MARK CONSISTS OF STANDARD CHARACTERS WITHOUT CLAIM TO ANY PARTICULAR FONT, STYLE, SIZE, OR COLOR.

FOR JEWELRY (U.S. CLS. 2, 27, 28 AND 50).
WILLIAM P. SHANAHAN, EXAMINING ATTORNEY

SN 85-310,480. GOT SHADES, INC., S. EL MONTE, CA. FILED 5-3-2011.



THE MARK CONSISTS OF A CROWNED LION HEAD. FOR WATCHES AND JEWELRY (U.S. CLS. 2, 27, 28 AND 50).
ANTHONY RINKER, EXAMINING ATTORNEY

CLASS 14—(Continued).

SN 85-317,976. BRILLIANT JEWELERS/MJJ INC., NEW YORK, NY. FILED 5-11-2011.

SWEET KARATS

THE MARK CONSISTS OF STANDARD CHARACTERS WITHOUT CLAIM TO ANY PARTICULAR FONT, STYLE, SIZE, OR COLOR.

FOR JEWELRY (U.S. CLS. 2, 27, 28 AND 50).
AISHA CLARKE, EXAMINING ATTORNEY

SN 85-318,247. GEORGE NEIL SAWYER, MINNEAPOLIS, MN. FILED 5-11-2011.

Koi

THE MARK CONSISTS OF STANDARD CHARACTERS WITHOUT CLAIM TO ANY PARTICULAR FONT, STYLE, SIZE, OR COLOR.

FOR BRACELETS; BROOCHES; JEWELRY; RINGS; WOMEN'S JEWELRY (U.S. CLS. 2, 27, 28 AND 50).
FIRST USE 2-0-2007; IN COMMERCE 2-0-2007.
SKYE YOUNG, EXAMINING ATTORNEY

SN 85-328,396. BRILLIANT JEWELERS/MJJ INC., NEW YORK, NY. FILED 5-24-2011.

TREASURED HEARTS

THE MARK CONSISTS OF STANDARD CHARACTERS WITHOUT CLAIM TO ANY PARTICULAR FONT, STYLE, SIZE, OR COLOR.

FOR JEWELRY (U.S. CLS. 2, 27, 28 AND 50).
AISHA CLARKE, EXAMINING ATTORNEY

CLASS 15—MUSICAL INSTRUMENTS

SN 85-125,002. CAJON DRUMZ, LLC, DBA LEWI CUSTOM CAJON DRUMZ, OAKLAND TOWNSHIP, MI. FILED 9-8-2010.



THE MARK CONSISTS OF A STYLIZED BIRD, A RING AND TWO FEATHERS. NEITHER COLOR NOR SHADING IS CLAIMED AS A FEATURE OF THE MARK.

FOR PERCUSSION INSTRUMENTS (U.S. CLS. 2, 21 AND 36).

FIRST USE 6-17-2010; IN COMMERCE 6-17-2010.
KHANH LE, EXAMINING ATTORNEY

SN 85-165,845. GIBSON GUITAR CORP., NASHVILLE, TN. FILED 11-1-2010.

AEOLIAN

THE MARK CONSISTS OF STANDARD CHARACTERS WITHOUT CLAIM TO ANY PARTICULAR FONT, STYLE, SIZE, OR COLOR.

FOR PIANOS (U.S. CLS. 2, 21 AND 36).
ELIZABETH KAJUBI, EXAMINING ATTORNEY

SN 85-247,683. CHARLES GREG DEERING, EL CAJON, CA. AND JANET L. DEERING, EL CAJON, CA. FILED 2-21-2011.



THE MARK CONSISTS OF THE WORD "GOODTIME" WITHIN A BANNER OUTLINE.

FOR MUSICAL INSTRUMENTS (U.S. CLS. 2, 21 AND 36).

FIRST USE 1-1-1997; IN COMMERCE 1-1-1997.
HENRY S. ZAK, EXAMINING ATTORNEY

CLASS 15—(Continued).

SN 85-258,352. WORLD LIBERTY (THAILAND) CO. LTD., BANGKOK, THAILAND, FILED 3-4-2011.

Karura

THE MARK CONSISTS OF STANDARD CHARACTERS WITHOUT CLAIM TO ANY PARTICULAR FONT, STYLE, SIZE, OR COLOR.

THE WORDING "KARURA" HAS NO MEANING IN A FOREIGN LANGUAGE.

FOR MUSICAL INSTRUMENT ACCESSORIES, NAMELY, STANDS, CASES, CARRYING BAGS AND STORAGE BAGS (U.S. CLS. 2, 21 AND 36).

FIRST USE 4-3-2006; IN COMMERCE 4-3-2006.
MAYUR VAGHANI, EXAMINING ATTORNEY

CLASS 15—(Continued).

SN 85-291,251. OCEAN BEACH DIGITAL, SAN DIEGO, CA. FILED 4-11-2011.



THE MARK CONSISTS OF A PALM TREE. FOR ELECTRIC AND ELECTRONIC MUSICAL INSTRUMENTS IN THE NATURE OF ELECTRONIC EFFECTS LEVERS FOR USE WITH MUSICAL INSTRUMENTS (U.S. CLS. 2, 21 AND 36).

FIRST USE 5-24-2010; IN COMMERCE 6-2-2010.
MICHAEL TANNER, EXAMINING ATTORNEY

SN 85-292,356. JARED B. REDDICK, DBA FREEFOOT, LLC, DUNNELLON, FL. FILED 4-11-2011.

FreeFoot

THE MARK CONSISTS OF STANDARD CHARACTERS WITHOUT CLAIM TO ANY PARTICULAR FONT, STYLE, SIZE, OR COLOR.

FOR DRUM PEDALS; DRUMS (U.S. CLS. 2, 21 AND 36).

MATTHEW EINSTEIN, EXAMINING ATTORNEY

SN 85-283,354. MOSTERT, MICHAEL, CALABASAS, CA. FILED 4-1-2011.



NO CLAIM IS MADE TO THE EXCLUSIVE RIGHT TO USE "THE ORIGINAL" AND "TUNERS", APART FROM THE MARK AS SHOWN.

THE COLOR(S) RED, GRAY, WHITE AND BLACK IS/ ARE CLAIMED AS A FEATURE OF THE MARK.

THE MARK CONSISTS OF THE LITERAL ELEMENTS "THE ORIGINAL GOGO TUNERS" WHEREIN THE WORDS "THE ORIGINAL" IN WHITE COLOR ARE PLACED ABOVE THE WORDS "GOGO TUNERS" IN RED COLOR WITH A NO. OF BROAD HORIZONTAL STRIPS IN GRAY COLOR DEPICTS AS A KEYS OF PIANO PLACED ABOVE THE WORDS "THE ORIGINAL" ALL ON A BLACK COLOR BACKGROUND AS SHOWN IN THE MARK.

FOR MUSICAL INSTRUMENT TUNER (U.S. CLS. 2, 21 AND 36).

SHAILA SETTLES, EXAMINING ATTORNEY

SN 85-293,773. GEORGE T. BRAITHWAITE, STATEN ISLAND, NY. FILED 4-13-2011.

BRAITHOPHONE

THE MARK CONSISTS OF STANDARD CHARACTERS WITHOUT CLAIM TO ANY PARTICULAR FONT, STYLE, SIZE, OR COLOR.

FOR MUSICAL INSTRUMENTS (U.S. CLS. 2, 21 AND 36).

RENEE MCCRAY, EXAMINING ATTORNEY

CLASS 15—(Continued).

SN 85-293,791. MUSAFIA ITALIA S.R.L., CREMONA, ITALY,
FILED 4-13-2011.

MUSAFIA

THE MARK CONSISTS OF STANDARD CHARACTERS WITHOUT CLAIM TO ANY PARTICULAR FONT, STYLE, SIZE, OR COLOR.

OWNER OF U.S. REG. NO. 2,115,664.
FOR CARRYING CASES FOR MUSICAL INSTRUMENTS (U.S. CLS. 2, 21 AND 36).
FIRST USE 0-0-1984; IN COMMERCE 0-0-1985.
GEORGE LORENZO, EXAMINING ATTORNEY

CLASS 16—PAPER GOODS AND PRINTED MATTER

SN 76-703,683. MONTOYA, BARBARA, EL PASO, TX. FILED 7-6-2010.

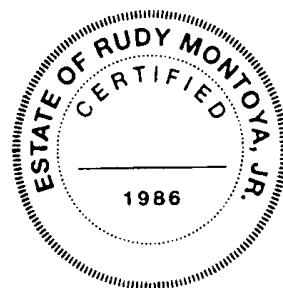

NO CLAIM IS MADE TO THE EXCLUSIVE RIGHT TO USE "ESTATE", "CERTIFIED" AND "1986", APART FROM THE MARK AS SHOWN.

THE NAME "RUDY MONTOYA, JR." DOES NOT IDENTIFY A LIVING INDIVIDUAL.

THE MARK CONSISTS OF THE DESIGN OF TWO CONCENTRIC CIRCLES WHICH ARE FORMED BY DOTTED LINES WITH THE STYLIZED WORDING "ESTATE OF RUDY MONTOYA, JR." APPEARING BETWEEN THE OUTER AND INNER CIRCLES AND THE WORDING "1986" APPEARING UNDER A LINE IN THE CENTER OF THE INNER CIRCLE.

FOR ART PICTURES, ART PRINTS, PRINTED ART REPRODUCTIONS (U.S. CLS. 2, 5, 22, 23, 29, 37, 38 AND 50).

FIRST USE 0-0-1986; IN COMMERCE 0-0-1986.
AMY C. KEAN, EXAMINING ATTORNEY

SN 76-704,903. HARVEY, STEVE, HOUSTON, TX. AND MCDONALD, RUSHION, HOUSTON, TX. AND ANDERSON, RICKY, HOUSTON, TX. FILED 10-15-2010.



OWNER OF U.S. REG. NO. 3,875,238.
THE COLOR(S) BLACK AND RED IS/ARE CLAIMED AS A FEATURE OF THE MARK.

THE MARK CONSISTS OF THE WORD "LOCATE" IN BLACK. THE "O" IN IS THE FORM OF A BLACK MAGNIFYING GLASS, AND THE WORD "YOUR" APPEARS IN RED INSIDE THE "O". THIS ALL APPEARS ABOVE THE WORD "LOVE" WITH A RED HEART FORMING THE "V" AND THE REST OF THE LETTERS IN BLACK. THE PRESENCE OF WHITE IS INTENDED TO INDICATE TRANSPARENCY AND IS NOT A FEATURE OF THE MARK.

FOR PRINTED GOODS, NAMELY, BOOKS IN THE FIELD OF LOVE, ROMANCE, RELATIONSHIPS, COMMITMENT, SEX, MARRIAGE, AND DATING, STATIONERY, CALENDARS, BOOKMARKS, POSTCARDS, ADHESIVE NOTE PADS, PENS AND PENCILS (U.S. CLS. 2, 5, 22, 23, 29, 37, 38 AND 50).

KATHERINE CHANG, EXAMINING ATTORNEY

SN 85-293,958. DREADNOUGHT, INC., WILMINGTON, DE.
FILED 4-13-2011.

Heart. Tone. Legend.

THE MARK CONSISTS OF STANDARD CHARACTERS WITHOUT CLAIM TO ANY PARTICULAR FONT, STYLE, SIZE, OR COLOR.

FOR STRINGS FOR MUSICAL INSTRUMENTS (U.S. CLS. 2, 21 AND 36).
GEORGE LORENZO, EXAMINING ATTORNEY

CLASS 16—(Continued).

SN 76-707,234. HANSEN PUBLISHING ENTERPRISES, INC., TOMS RIVER, NJ. FILED 4-12-2011.

BEACHCOMBER MAGAZINE.COM

THE MARK CONSISTS OF STANDARD CHARACTERS WITHOUT CLAIM TO ANY PARTICULAR FONT, STYLE, SIZE, OR COLOR.

NO CLAIM IS MADE TO THE EXCLUSIVE RIGHT TO USE "MAGAZINE.COM", APART FROM THE MARK AS SHOWN.

FOR PUBLICATIONS, NAMELY, A MAGAZINE IN THE FIELD OF ADVERTISEMENTS AND INFORMATION CONCERNING THE NEW JERSEY BEACH AREA (U.S. CLS. 2, 5, 22, 23, 29, 37, 38 AND 50).

FIRST USE 1-0-1988; IN COMMERCE 1-0-1988.
IRA J. GOODSaid, EXAMINING ATTORNEY

CLASS 16—(Continued).

SN 77-248,388. PATTON, ANTWAN, LOS ANGELES, CA. FILED 8-6-2007.

BIG BOI

THE MARK CONSISTS OF STANDARD CHARACTERS WITHOUT CLAIM TO ANY PARTICULAR FONT, STYLE, SIZE, OR COLOR.

THE WORDING "BOI" HAS NO MEANING IN A FOREIGN LANGUAGE.

FOR PRINTED MATTER, PAPER AND STATIONERY PRODUCTS, NAMELY, POSTERS, POSTER BOOKS, CALENDARS, CONCERT SOUVENIR PROGRAMS, STICKERS, BUMPER STICKERS, TRADING CARDS, PENS, PENCILS, DECALS, PHOTOGRAPHS, SHEET MUSIC, AND BOOKS AND MAGAZINES IN THE FIELDS OF MUSIC, ENTERTAINMENT, ART AND/OR CULTURE (U.S. CLS. 2, 5, 22, 23, 29, 37, 38 AND 50).

FRANK LATTUCA, EXAMINING ATTORNEY

SN 77-922,268. THE CLIMATIC CORPORATION, COLUMBIA, SC. FILED 1-28-2010.



SN 76-708,184. 3L-LUDVIGSEN A/S, TOMMERUP, DENMARK, FILED 7-10-2009.

Click 'n Stick

THE MARK CONSISTS OF STANDARD CHARACTERS WITHOUT CLAIM TO ANY PARTICULAR FONT, STYLE, SIZE, OR COLOR.

PRIORITY CLAIMED UNDER SEC. 44(D) ON DENMARK APPLICATION NO. VA200901745, FILED 6-8-2009.

FOR DISPENSERS FOR DISPENSING ADHESIVES FOR HOUSEHOLD, SCHOOL AND STATIONERY PURPOSES; DISPENSERS FOR DISPENSING ADHESIVES FOR MOUNTING PHOTOGRAPHS, PAPER, IMAGES, PICTURES, DECORATIVE ELEMENTS AND ARTICLES USED IN SCRAPBOOKING; ADHESIVES AND GLUE FOR HOUSEHOLD, SCHOOL AND STATIONERY PURPOSES; ADHESIVES AND GLUE FOR MOUNTING PHOTOGRAPHS, PAPER, IMAGES, PICTURES, DECORATIVE ELEMENTS AND ARTICLES USED IN SCRAPBOOKING; REFILLS FOR THE MENTIONED DISPENSERS (U.S. CLS. 2, 5, 22, 23, 29, 37, 38 AND 50).

SUZANNE BLANE, EXAMINING ATTORNEY

NO CLAIM IS MADE TO THE EXCLUSIVE RIGHT TO USE "CLIMATIC COMFORT PRODUCTS MANAGED AIR PROGRAM", APART FROM THE MARK AS SHOWN.

THE COLOR(S) BLUE, ORANGE, YELLOW AND RED IS/ARE CLAIMED AS A FEATURE OF THE MARK.

THE MARK CONSISTS OF SIX (6) CRESCENT-SHAPED FIGURES OF DIFFERENT SIZES ARRANGED IN A CIRCULAR PATTERN TO CREATE A SWIRL. THREE (3) OF THE CRESCENT SHAPES ARE VARYING SHADES OF BLUE, AND THE OTHER THREE (3) CRESCENT SHAPES ARE VARYING SHADES OF YELLOW, ORANGE AND RED. THERE ARE TWO (2) LINES OF TEXT TO THE RIGHT OF THE SWIRL. THE WORDS "CLIMATIC COMFORT PRODUCTS" APPEAR ON THE TOP LINE IN SMALLER TYPE THAN THE WORDS "MANAGED AIR PROGRAM", WHICH APPEAR ON THE LOWER LINE. ALL OF THE TEXT IS BLUE WITH RED SHADING AROUND/BEHIND THE TEXT.

FOR PUBLICATIONS, NAMELY, BROCHURES, BOOKLETS, AND TEACHING MATERIALS IN THE FIELD OF HEATING, VENTILATING AND AIR CONDITIONING (U.S. CLS. 2, 5, 22, 23, 29, 37, 38 AND 50).

FIRST USE 3-19-2009; IN COMMERCE 3-24-2009.
LINDA M. KING, EXAMINING ATTORNEY

CLASS 16—(Continued).

SN 77-940,779. THE PLAYMAKER COMPANY, GLEN MILLS, PA. FILED 2-21-2010.

PLAYMAKERXO

THE MARK CONSISTS OF STANDARD CHARACTERS WITHOUT CLAIM TO ANY PARTICULAR FONT, STYLE, SIZE, OR COLOR.

FOR MECHANICAL DRAWING DEVICE IN THE FORM OF A CLIPBOARD WITH THE CAPABILITY TO INSTANTLY ERASE FOR INSTRUCTIONAL USE IN SPORTS OR ATHLETICS (U.S. CLS. 2, 5, 22, 23, 29, 37, 38 AND 50).

MARC LEIPZIG, EXAMINING ATTORNEY

SN 77-965,035. BENJAMIN, ERIC, EMPORIO, KS. FILED 3-22-2010.

ADVENTURE MONKEY

THE MARK CONSISTS OF STANDARD CHARACTERS WITHOUT CLAIM TO ANY PARTICULAR FONT, STYLE, SIZE, OR COLOR.

FOR GENERAL FEATURE MAGAZINE IN THE FIELD OF OUTDOOR ACTIVITIES AND GENERAL LIFESTYLE TOPICS (U.S. CLS. 2, 5, 22, 23, 29, 37, 38 AND 50).

FIRST USE 3-0-2010; IN COMMERCE 3-0-2010.

HOWARD B. LEVINE, EXAMINING ATTORNEY



SN 79-088,884. ACCO UK LIMITED, UNITED KINGDOM, FILED 10-11-2010.

KLIX

THE MARK CONSISTS OF STANDARD CHARACTERS WITHOUT CLAIM TO ANY PARTICULAR FONT, STYLE, SIZE, OR COLOR.

OWNER OF INTERNATIONAL REGISTRATION 1037761 DATED 4-14-2010, EXPIRES 4-14-2020.

FOR PAPER CLIPS; STATIONERY CLIPS, NAMELY PAPER FASTENERS; BINDER CLIPS, MEMO CLIPS AND NOTE CLIPS (U.S. CLS. 2, 5, 22, 23, 29, 37, 38 AND 50).

STEVEN JACKSON, EXAMINING ATTORNEY

CLASS 16—(Continued).

SN 79-090,020. HEILONGJIANG ZHONGHAO STARCH-BASED BIODEGRADABLE MATERIALS CO., LTD, CHINA, FILED 5-11-2010.

PRIORITY DATE OF 3-9-2010 IS CLAIMED.

OWNER OF INTERNATIONAL REGISTRATION 1058384 DATED 5-11-2010, EXPIRES 5-11-2020.

THE MARK CONSISTS OF A STYLIZED SMILEY FACE WITH THE EYES AND MOUTH IN DARK SHADING. THE SMILEY FACE IS OUTLINED IN LIGHT SHADING WITH AN INCOMPLETE OVAL. THE TOP OF OUTLINE IS COMPRISED OF THREE STYLIZED LEAVES.

FOR PACKAGING MATERIAL MADE OF STARCHES AS PAPER SUBSTITUTES; GARBAGE BAGS OF PAPER AND OF PLASTICS; BAGS IN THE NATURE OF ENVELOPES AND POUCHES AND PLASTICS, FOR PACKAGING; CANDY WRAPPING PAPER; PLASTIC FILM FOR WRAPPING; FILMS FOR WRAPPING FOODSTUFFS FOR HOUSEHOLD USE; PLASTIC BUBBLE PACKS FOR WRAPPING OR PACKAGING; PACKING PAPER; PENCILS; COASTERS OF PAPER (U.S. CLS. 2, 5, 22, 23, 29, 37, 38 AND 50).

MARILYN IZZI, EXAMINING ATTORNEY

CLASS 16—(Continued).

SN 85-013,215. NJENGA, WAMORO P., MAMARONECK, NY.
FILED 4-13-2010.



THE MARK CONSISTS, IN PART, OF TWO HUMAN FIGURES REACHING FOR THE STAR WHILE STANDING ON THE MOON WHICH IS PROPPED UP BY TWO GIRAFFES.

FOR ART PRINTS; ART PRINTS ON CANVAS; BABY BOOKS; BIRTHDAY BOOKS; BLANK CARDS; BLANK OR PARTIALLY PRINTED POSTCARDS; CARTOON PRINTS; CHILDREN'S ACTIVITY BOOKS; CHILDREN'S BOOKS; CHRISTMAS CARDS; COLOR PRINTS; FLIP BOOKS; FRAMED ART PRINTS; GIFT BOOKS FEATURING ART, PHOTOGRAPHS AND RELIGIOUS PASSAGES, SERIES OF FICTION BOOKS, NAMELY, NOVELS, INSPIRATIONAL AND SELF HELP BOOKS AND CHILDRENS BOOKS; GREETING CARDS; GREETING CARDS HAVING A CHRISTIAN MESSAGE; GREETINGS CARDS AND POSTCARDS; HOLIDAY CARDS; INVITATION CARDS; MOTIVATIONAL CARDS; PATTERNS FOR MAKING CLOTHES; PATTERNS FOR MAKING CLOTHING; PAPER GOODS, NAMELY, PAPER PARTY DECORATIONS AND PAPER PARTY BAGS; PHOTOGRAPHIC PRINTS; PICTORIAL PRINTS; PICTURE BOOKS; PRAYER BOOKS; PRINTED ART REPRODUCTIONS; PRINTED CALENDARS; PRINTED CERTIFICATES; PRINTED EDUCATIONAL MATERIALS IN THE FIELD OF SCIENCE; PERIODICALS, NAMELY, MAGAZINES, NEWSLETTERS, AND WORKBOOKS IN THE FIELD OF SCIENCE, SELF-HELP AND POETRY; ART REPRODUCTIONS; PAPER LABELS; CALENDARS; PRINTED FORMS; PRINTED INVITATIONS; PRINTED PAPER LABELS; PRINTED PAPER SIGNS; PRINTED PATTERNS; PRINTS; PUBLICATIONS, NAMELY, FUNDRAISING PAMPHLETS IN THE FIELD OF DISPLACED CHILDREN AND ORPHANS; SERIES OF FICTION WORKS, NAMELY, NOVELS AND BOOKS (U.S. CLS. 2, 5, 22, 23, 29, 37, 38 AND 50).

MICHELE SWAIN, EXAMINING ATTORNEY

SN 85-015,165. KNOWLEDGE UNIVERSE EDUCATION LLC,
PORTLAND, OR. FILED 4-15-2010.

GUIDED DISCOVERY

THE MARK CONSISTS OF STANDARD CHARACTERS WITHOUT CLAIM TO ANY PARTICULAR FONT, STYLE, SIZE, OR COLOR.

FOR PRINTED INSTRUCTIONAL, EDUCATIONAL, AND TEACHING MATERIALS, NAMELY, TEACHING ACTIVITY GUIDES, CURRICULUM SHEETS, PLANNING MAPS, TRAINING GUIDES, AGE GROUP MANUALS, ALL IN THE SUBJECTS OF ELEMENTARY EDUCATION (U.S. CLS. 2, 5, 22, 23, 29, 37, 38 AND 50).
FIRST USE 9-0-1997; IN COMMERCE 9-0-1997.

LEIGH CAROLINE CASE, EXAMINING ATTORNEY

CLASS 16—(Continued).

SN 85-017,790. PAL BRANDS LIMITED, AUCKLAND, NEW ZEALAND, FILED 4-20-2010.



OWNER OF NEW ZEALAND REG. NO. 732064, DATED 1-5-2006, EXPIRES 7-1-2015.

NO CLAIM IS MADE TO THE EXCLUSIVE RIGHT TO USE "CONTRACT PROFESSIONAL", APART FROM THE MARK AS SHOWN.

THE MARK CONSISTS OF A "P" INSIDE A CIRCLE SURROUNDED BY THE WORDS "CONTRACT PROFESSIONAL".

FOR PAINT BRUSHES, PAINT ROLLERS, PAINT PADDLES, PAINT STIRRERS, PAINT APPLICATORS AND PAINT TRAYS (U.S. CLS. 2, 5, 22, 23, 29, 37, 38 AND 50).

SHAILA SETTLES, EXAMINING ATTORNEY

SN 85-064,215. TEXAS EDUCATION AGENCY, AUSTIN, TX.
FILED 6-16-2010.

STAAR

THE MARK CONSISTS OF STANDARD CHARACTERS WITHOUT CLAIM TO ANY PARTICULAR FONT, STYLE, SIZE, OR COLOR.

FOR PRINTED INSTRUCTIONAL, EDUCATIONAL, AND TEACHING MATERIALS FOR THE ASSESSMENT OF THE EDUCATIONAL DEVELOPMENT IN CHILDREN (U.S. CLS. 2, 5, 22, 23, 29, 37, 38 AND 50).

GINA HAYES, EXAMINING ATTORNEY

CLASS 16—(Continued).

SN 85-081,394. NINTENDO OF AMERICA INC., REDMOND, WA. FILED 7-9-2010.

POKÉMON

THE MARK CONSISTS OF STANDARD CHARACTERS WITHOUT CLAIM TO ANY PARTICULAR FONT, STYLE, SIZE, OR COLOR.

OWNER OF U.S. REG. NOS. 2,358,735, 2,358,738 AND OTHERS.

FOR ADDRESS BOOKS; ARTISTS' BRUSHES; ARTISTS' PASTELS; ARTS AND CRAFTS PAINT KITS; BOOK COVERS; BOOKPLATES; CALENDARS; CARDBOARD GIFT BOXES; COLORING BOOKS; COMIC BOOKS; CRAYONS; DECORATIVE FIGURES ATTACHABLE TO PENCILS, NAMELY, PENCIL ORNAMENTS; DRAWING RULERS; DRY ERASE WRITING BOARDS; ERASERS; FELT-TIP MARKERS; GIFT WRAPPING PAPER; IRON-ON TRANSFERS; BOOKS, BOOKLETS AND MANUALS REGARDING VIDEO GAMES; MAGNETIC SLATE BOARDS FOR WRITING; MEMO BOARDS; MEMO PADS; NEWSPAPER CARTOONS; NOTEBOOKS; NOTEPADS; PAINTING SETS FOR CHILDREN; PAPER BANNERS; PAPER DECORATIONS MOUNTABLE ON DOORS; PAPER NAPKINS; PAPER PARTY FAVORS; PAPER PLACEMATS; PAPER STAPLERS; UNFITTED PAPER TABLE COVERS; PENCIL BOXES WITH MAGNETIC CLOSURES; PENCIL SHARPENERS; PENCILS; PENS; POSTCARDS; RUBBER STAMPS; SCORE BOOKS; SCRAPBOOKS AND STAMP COLLECTOR BOOKS; SCRATCH PADS; STAPLERS IN THE NATURE OF OFFICE REQUISITES; STATIONERY-TYPE PORTFOLIOS; STICKER ALBUMS; STYLUS (U.S. CLS. 2, 5, 22, 23, 29, 37, 38 AND 50).

ANNE FARRELL, EXAMINING ATTORNEY

CLASS 16—(Continued).

SN 85-099,529. IMAGINATION BRANDS CO., LLC, BEVERLY, MA. FILED 8-3-2010.

Handswrap

THE MARK CONSISTS OF STANDARD CHARACTERS WITHOUT CLAIM TO ANY PARTICULAR FONT, STYLE, SIZE, OR COLOR.

FOR PAPER FOR WRAPPING GROCERY CART HANDLES (U.S. CLS. 2, 5, 22, 23, 29, 37, 38 AND 50).

WARREN L. OLANDRIA, EXAMINING ATTORNEY

SN 85-112,878. W.B. MASON CO., INC., BROCKTON, MA. FILED 8-21-2010.



The logo for "mycopy PAPER" features the word "mycopy" in a lowercase, sans-serif font. "my" is blue and "copy" is red. Below "mycopy", the word "PAPER" is written in a smaller, blue, all-caps, sans-serif font, with each letter centered under a corresponding letter in "mycopy".

NO CLAIM IS MADE TO THE EXCLUSIVE RIGHT TO USE "PAPER", APART FROM THE MARK AS SHOWN.

THE COLOR(S) RED AND BLUE IS/ARE CLAIMED AS A FEATURE OF THE MARK.

THE MARK CONSISTS OF STYLIZED LETTERING, WITH THE WORD "MY" IN BLUE AND "COPY" IN RED WITH THE WORD "PAPER" IN SMALLER CAPITAL LETTERS IN BLUE IMMEDIATELY BELOW STARTING AT THE END OF THE WORD "MY" AND THE BEGINNING OF THE WORD "COPY".

FOR COPIER PAPER; COPYING PAPER; COPYPAPER (U.S. CLS. 2, 5, 22, 23, 29, 37, 38 AND 50).

FIRST USE 10-1-2007; IN COMMERCE 10-1-2007.

JOSETTE BEVERLY, EXAMINING ATTORNEY

SN 85-118,602. CATHY CONNER JORDAN, BOISE, ID. FILED 8-30-2010.



THE MARK CONSISTS OF THE WORD "WARI" PRESENTED IN STYLIZED HANDWRITTEN FORM SET AT A DIAGONAL. THE MARK APPEARS IN REVERSE TONES ON A SOLID BACKGROUND.

THE WORDING "WARI" HAS NO MEANING IN A FOREIGN LANGUAGE.

FOR ART PICTURES, ART PRINTS, ART ETCHINGS (U.S. CLS. 2, 5, 22, 23, 29, 37, 38 AND 50).

FIRST USE 1-1-1990; IN COMMERCE 1-1-1990.

STEVEN PEREZ, EXAMINING ATTORNEY

SN 85-092,261. BUCCELLI JAMES, SHERMAN OAKS, CA. FILED 7-24-2010.

Fake Magazine

THE MARK CONSISTS OF STANDARD CHARACTERS WITHOUT CLAIM TO ANY PARTICULAR FONT, STYLE, SIZE, OR COLOR.

NO CLAIM IS MADE TO THE EXCLUSIVE RIGHT TO USE "MAGAZINE", APART FROM THE MARK AS SHOWN.

FOR MAGAZINES IN THE FIELD OF FASHION, BEAUTY, ENTERTAINMENT AND LIFESTYLE (U.S. CLS. 2, 5, 22, 23, 29, 37, 38 AND 50).

MICHELE SWAIN, EXAMINING ATTORNEY

CLASS 16—(Continued).

SN 85-122,151. DIXON TICONDEROGA COMPANY, HEATHROW, FL. FILED 9-2-2010.

PRANG

THE MARK CONSISTS OF STANDARD CHARACTERS WITHOUT CLAIM TO ANY PARTICULAR FONT, STYLE, SIZE, OR COLOR.

OWNER OF U.S. REG. NOS. 747,882, 1,005,583 AND 3,387,731.

FOR MODELING CLAY, CRAYONS, PENCILS, MARKERS, PENS, CHALK, CHALKBOARD ERASERS, ERASERS, PAINT BRUSHES, GLUE STICKS FOR STATIONERY OR HOUSEHOLD USE, AND PAINTING SETS FOR CHILDREN COMPRISED OF PAINT-BRUSHES AND PAINTS (U.S. CLS. 2, 5, 22, 23, 29, 37, 38 AND 50).

FIRST USE 6-1-1993; IN COMMERCE 6-1-1993.
NELSON SNYDER, EXAMINING ATTORNEY

SN 85-123,710. GROVE ATLANTIC LIMITED, LONDON, UNITED KINGDOM, FILED 9-7-2010.

CALLISTO

THE MARK CONSISTS OF STANDARD CHARACTERS WITHOUT CLAIM TO ANY PARTICULAR FONT, STYLE, SIZE, OR COLOR.

OWNER OF UNITED KINGDOM REG. NO. 2542138, DATED 6-25-2010, EXPIRES 6-25-2020.

FOR BOOKS IN THE FIELD OF GENERAL NON-FICTION (U.S. CLS. 2, 5, 22, 23, 29, 37, 38 AND 50).

JOHN WILKE, EXAMINING ATTORNEY

CLASS 16—(Continued).

SN 85-126,062. ZALLINGER FAMILY, LLC, GREENVILLE, DE. FILED 9-9-2010.



THE MARK CONSISTS OF A PICTORIAL DESCRIPTION OF A PROGRESSION OF HUMAN DEVELOPMENT ON A STRAIGHT HORIZONTAL, FROM LEFT TO RIGHT, MOVING FROM THE LEAST DEVELOPED TO THE MOST DEVELOPED.

FOR METAL MONEY CLIPS, PAPER GOODS AND PRINTED MATTER, NAMELY, TRADING CARDS, PLAYING CARDS, BUMPER STICKERS, POSTERS, STICKERS, DECALS, BOOKMARKS, PRINTED PAPER SIGNS, WRITING PADS, STICKY NOTES IN THE NATURE OF ADHESIVE NOTE PADS, NOTE PAPER, NOTEBOOKS, COLORING BOOKS, PREPRINTED AGENDA ORGANIZERS FOR STATIONERY USE, BOOKS AND BOOKLETS FEATURING EVOLUTION, BOOK COVERS, CALENDARS, WALL CALENDARS, DESK CALENDARS, PAPER PENNANTS, GIFT WRAPPING PAPER, PACKAGING FOR FOOD IN THE FORM OF PAPER PACKAGING CONTAINERS, PACKAGING FOR CANDY IN THE FORM OF PAPER PACKAGING CONTAINERS, PAPER GIFT WRAP BOWS, PAPER GIFT AND PARTY BAGS, PAPER PARTY DECORATIONS, PAPER COASTERS, PAPER FLAGS, PAPER NAPKINS, PAPER TABLECLOTHS, PAPER PLACEMATS, GREETING CARDS, POSTCARDS, UNMOUNTED PHOTOGRAPHS, LITHOGRAPHS, DOOR SIGNS, PHOTOGRAPH ALBUMS, SCRAPBOOKS, BINDERS, STATIONERY-TYPE PORTFOLIOS, STATIONERY FOLDERS, BANK CHECKS, CHECKBOOK COVERS, CREDIT CARDS WITHOUT MAGNETIC CODING, PAPERWEIGHTS, LETTER OPENERS, PAPER CLIPS, PENS, PENCILS, MARKERS, DESK STANDS AND HOLDERS FOR PENS, PENCILS AND INK, NON-ELECTRIC ERASERS, PENCIL SHARPENERS, DRAFTING AND DRAWING RULERS, COLLECTIBLE STAMPS IN THE NATURE OF COMMEMORATIVE STAMP SHEETS, FACIAL TISSUE, DECORATIVE PENCIL TOP ORNAMENTS, NON-METAL MONEY CLIPS, TEMPORARY TATTOOS, PAPER FOOD AND BEVERAGE LABELS INCLUDING ALCOHOLIC BEVERAGE LABELS (U.S. CLS. 2, 5, 22, 23, 29, 37, 38 AND 50).

TINA MAI, EXAMINING ATTORNEY

SN 85-129,444. ENTERTAINMENT WEEKLY INC., NEW YORK, NY. FILED 9-14-2010.

EW

THE MARK CONSISTS OF STANDARD CHARACTERS WITHOUT CLAIM TO ANY PARTICULAR FONT, STYLE, SIZE, OR COLOR.

OWNER OF U.S. REG. NOS. 2,649,314, 3,548,428 AND OTHERS.

FOR MAGAZINE SECTIONS IN THE FIELD OF MOVIES, TELEVISION, PUBLISHING, MUSIC, MULTIMEDIA, VIDEOS, PERSONALITIES, CELEBRITIES, POPULAR CULTURE AND TOPICS OF GENERAL INTEREST; MAGAZINES IN THE FIELD OF MOVIES, TELEVISION, PUBLISHING, MUSIC, MULTIMEDIA, VIDEOS, PERSONALITIES, CELEBRITIES, POPULAR CULTURE AND TOPICS OF GENERAL INTEREST (U.S. CLS. 2, 5, 22, 23, 29, 37, 38 AND 50).

VIVIAN MICZNIK FIRST, EXAMINING ATTORNEY

CLASS 16—(Continued).

SN 85-129,732. PACOBOND, INC., SUN VALLEY, CA. FILED 9-15-2010.

EUROSAC

THE MARK CONSISTS OF STANDARD CHARACTERS WITHOUT CLAIM TO ANY PARTICULAR FONT, STYLE, SIZE, OR COLOR.

FOR GENERAL PURPOSE PLASTIC BAGS; MERCHANDISE BAGS; PAPER BAGS AND SACKS; PAPER BAGS FOR PACKAGING; PAPER GIFT BAGS; PAPER SHOPPING BAGS; PLASTIC BAGS FOR PACKAGING; PLASTIC BAGS FOR PACKING; PLASTIC OR PAPER BAGS FOR MERCHANDISE PACKAGING; PLASTIC SHOPPING BAGS (U.S. CLS. 2, 5, 22, 23, 29, 37, 38 AND 50).

FIRST USE 1-1-1991; IN COMMERCE 1-1-1991.
CIMMERIAN COLEMAN, EXAMINING ATTORNEY

SN 85-130,272. LJMC, LLC, FORT THOMAS, KY. FILED 9-15-2010.

GET LICKED

THE MARK CONSISTS OF STANDARD CHARACTERS WITHOUT CLAIM TO ANY PARTICULAR FONT, STYLE, SIZE, OR COLOR.

FOR TEMPORARY TATTOOS (U.S. CLS. 2, 5, 22, 23, 29, 37, 38 AND 50).

HANNO RITTNER, EXAMINING ATTORNEY

SN 85-130,341. EMILY JO FOWLER, HARRISON TOWNSHIP, MI. FILED 9-15-2010.

THE ZXK ADVERSARY

THE MARK CONSISTS OF STANDARD CHARACTERS WITHOUT CLAIM TO ANY PARTICULAR FONT, STYLE, SIZE, OR COLOR.

FOR SERIES OF SCIENCE FICTION BOOKS (U.S. CLS. 2, 5, 22, 23, 29, 37, 38 AND 50).

APRIL ROACH, EXAMINING ATTORNEY

CLASS 16—(Continued).

SN 85-131,672. OPPORTUNITY HOLDING, LLC, SAN ANTONIO, TX. FILED 9-16-2010.

ARDYSS

THE MARK CONSISTS OF STANDARD CHARACTERS WITHOUT CLAIM TO ANY PARTICULAR FONT, STYLE, SIZE, OR COLOR.

OWNER OF U.S. REG. NOS. 2,768,771, 3,221,455 AND OTHERS.

FOR DIRECT SELLING AIDS AND SALES LITERATURE, NAMELY, BUSINESS CARDS, LETTERHEAD, WRITING PAPER, ENVELOPES, POSTCARDS, NEWSLETTERS IN THE FIELD OF DIRECT SALES AND MARKETING AND MAGAZINES IN THE FIELD OF DIRECT SALES AND MARKETING (U.S. CLS. 2, 5, 22, 23, 29, 37, 38 AND 50).

FIRST USE 1-22-2002; IN COMMERCE 1-22-2002.
ALEXANDER L. POWERS, EXAMINING ATTORNEY

SN 85-133,663. ONE RACE - WRYBB, INC., ORLANDO, FL. FILED 9-20-2010.

One Race Kids

THE MARK CONSISTS OF STANDARD CHARACTERS WITHOUT CLAIM TO ANY PARTICULAR FONT, STYLE, SIZE, OR COLOR.

NO CLAIM IS MADE TO THE EXCLUSIVE RIGHT TO USE "KIDS", APART FROM THE MARK AS SHOWN.

FOR CHILDREN'S BOOKS (U.S. CLS. 2, 5, 22, 23, 29, 37, 38 AND 50).

FIRST USE 9-15-2010; IN COMMERCE 9-15-2010.
LINDA ORNDORFF, EXAMINING ATTORNEY

CLASS 16—(Continued).

SN 85-134,100. OPPORTUNITY HOLDING, LLC, SAN ANTONIO, TX. FILED 9-20-2010.



OWNER OF U.S. REG. NOS. 2,768,771, 3,221,455 AND OTHERS.

THE MARK CONSISTS OF THE WORD "ARDYSS" WITH A DOUBLE LEAF DESIGN OVER THE "D" AND "Y" IN "ARDYSS".

FOR DIRECT SELLING AIDS AND SALES LITERATURE, NAMELY, BUSINESS CARDS, LETTERHEAD, WRITING PAPER, ENVELOPES, POSTCARDS, NEWSLETTERS IN THE FIELD OF DIRECT SALES AND MARKETING AND MAGAZINES IN THE FIELD OF DIRECT SALES AND MARKETING (U.S. CLS. 2, 5, 22, 23, 29, 37, 38 AND 50).

FIRST USE 3-31-2008; IN COMMERCE 3-31-2008.
ALEXANDER L. POWERS, EXAMINING ATTORNEY

CLASS 16—(Continued).

SN 85-138,471. DEAN, KENDEN, BEDFORD, TX. FILED 9-27-2010.



NO CLAIM IS MADE TO THE EXCLUSIVE RIGHT TO USE "THE PROGRAM", APART FROM THE MARK AS SHOWN.

THE COLOR(S) WHITE, BLACK AND RED IS/ARE CLAIMED AS A FEATURE OF THE MARK.

THE MARK CONSISTS OF THE LETTER "G" WITH A RIBBON OVER IT IN WHITE COLOR WITH BLACK AND RED BORDERS AND THE WORDS "THE PROGRAM" ARE WRITTEN ON THE RIBBON IN BLACK COLOR.

FOR POSTERS, TEXT BOOKS, WORKBOOK AND ACTIVITY BOOKS TO PROMOTE THE TEACHINGS OF VALUES AND GOOD CHARACTER (U.S. CLS. 2, 5, 22, 23, 29, 37, 38 AND 50).

FIRST USE 6-14-2008; IN COMMERCE 6-14-2008.
KAREN K. BUSH, EXAMINING ATTORNEY

SN 85-140,951. NOVELLUS HEALTHCARE COMMUNICATIONS, LLC, MONROE TOWNSHIP, NJ. FILED 9-29-2010.

SN 85-135,218. KITARU INNOVATIONS INC., LASCELLES, BARBADOS, FILED 9-22-2010.



2 SIDE IT

THE MARK CONSISTS OF STANDARD CHARACTERS WITHOUT CLAIM TO ANY PARTICULAR FONT, STYLE, SIZE, OR COLOR.

OWNER OF U.S. REG. NO. 2,848,136.

FOR ADHESIVE TAPE FOR HOME, OFFICE, SCHOOL AND GENERAL USE, EXCLUDING REMOVABLE OR REPOSITIONABLE ADHESIVE TAPE PRODUCTS (U.S. CLS. 2, 5, 22, 23, 29, 37, 38 AND 50).

FIRST USE 1-30-2002; IN COMMERCE 1-30-2002.
TIMOTHY FINNEGAN, EXAMINING ATTORNEY

NO CLAIM IS MADE TO THE EXCLUSIVE RIGHT TO USE "PEDIATRIC NP/PA THE OFFICIAL NEWSPAPER FOR THE PEDIATRIC/ADOLESCENT NURSE AND ADVANCED PRACTITIONER", APART FROM THE MARK AS SHOWN.

THE MARK CONSISTS OF THE WORDS "PEDIATRIC NP/PA" WHERE THERE IS A CHILDREN'S CRAYON-LIKE DRAWING OF A SUN BETWEEN THE WORDS "PEDIATRIC AND NP/PA". SUPERIMPOSED IN FRONT OF THE SUN IS AN IMPRESSIONISTIC RENDERING OF A BOY AND A GIRL WITH THEIR ARMS UP IN THE AIR. THERE IS A STRAIGHT HORIZONTAL LINE UNDERSCORING THE PHRASE "PEDIATRIC NP/PA". UNDERNEATH THE HORIZONTAL LINE IS THE TAG-LINE, ON TWO SEPARATE LINES "THE OFFICIAL NEWSPAPER FOR THE PEDIATRIC/ADOLESCENT NURSE AND ADVANCED PRACTITIONER".

FOR PRINTED PUBLICATIONS, NAMELY, NEWSPAPERS, NEWSLETTERS, FEATURE REPORTS, MONOGRAPHS, AND SUPPLEMENTS IN THE FIELDS OF PEDIATRICS AND NURSING (U.S. CLS. 2, 5, 22, 23, 29, 37, 38 AND 50).

DANNEAN HETZEL, EXAMINING ATTORNEY

CLASS 16—(Continued).

SN 85-143,315. YOSEMITE FOUNDATION, SAN FRANCISCO, CA. FILED 10-1-2010.



**YOSEMITE
CONSERVANCY**

OWNER OF U.S. REG. NO. 3,190,567.

NO CLAIM IS MADE TO THE EXCLUSIVE RIGHT TO USE "YOSEMITE CONSERVANCY", APART FROM THE MARK AS SHOWN.

THE MARK CONSISTS OF A MOUNTAIN WITH TREES IN FRONT INSIDE A SQUARE BORDER WITH THE WORDS "YOSEMITE CONSERVANCY" BELOW THE DESIGN.

FOR GREETING CARDS; HOLIDAY CARDS; POSTCARDS; PRINTED ART REPRODUCTIONS; CALENDARS; POSTERS, MAPS; BOOKS, BOOKLETS, PAMPHLETS, MAGAZINES AND NEWSLETTERS ALL IN THE FIELDS OF CONSERVATION OF NATURAL RESOURCES, BIOLOGY, BOTANY, ART, PHOTOGRAPHY, AND HISTORY (U.S. CLS. 2, 5, 22, 23, 29, 37, 38 AND 50).

FIRST USE 9-27-2010; IN COMMERCE 9-27-2010.
JAMES STEIN, EXAMINING ATTORNEY

SN 85-143,924. LITTLE, RODNEY TRENT, DBA RODNEY LITTLE, WASHINGTON, DC. FILED 10-3-2010.



THE COLOR(S) BLACK, BLUE, AND RED IS/ARE CLAIMED AS A FEATURE OF THE MARK.

THE MARK CONSISTS OF THE WORDING, "CHEAP AZZ BROTHA", IN RED LETTERS ON A BLUE BACKGROUND WITH BLACK INSERTS BETWEEN AND INSIDE THE LETTERS, WITH THE "C" REPRESENTED BY THE CENT SYMBOL, AND THE ENTIRE DESIGN OUTLINED IN BLACK.

FOR COMIC STRIPS (U.S. CLS. 2, 5, 22, 23, 29, 37, 38 AND 50).

BARBARA A. GOLD, EXAMINING ATTORNEY

CLASS 16—(Continued).

SN 85-147,786. PHOTO DISPLAY PRODUCTS, LLC, DBA PHOTOGRAPHER'S EDGE, COLORADO SPRINGS, CO. FILED 10-7-2010.



Greetings to frame and enjoy

NO CLAIM IS MADE TO THE EXCLUSIVE RIGHT TO USE "EDITION", APART FROM THE MARK AS SHOWN.

THE MARK CONSISTS OF THE WORDING "THE GALLERY EDITION" SUPERIMPOSED ON TOP OF A PICTURE FRAME. THE WORDING "THE" IS SHOWN VERTICALLY. THE WORDING "GALLERY" IS UNDERLINED AND THE WORDING "EDITION" IS IN STYLIZED FONT. THE WORDING "GREETINGS TO FRAME AND ENJOY" APPEARS UNDER THE WORDING "THE GALLERY EDITION".

FOR GREETING CARDS (U.S. CLS. 2, 5, 22, 23, 29, 37, 38 AND 50).

SETH A. RAPPAPORT, EXAMINING ATTORNEY

SN 85-149,246. RIEPE, BRIAN, GUNNISON, CO. FILED 10-10-2010.

MOUNTAINFLYER

THE MARK CONSISTS OF STANDARD CHARACTERS WITHOUT CLAIM TO ANY PARTICULAR FONT, STYLE, SIZE, OR COLOR.

FOR GENERAL FEATURE MAGAZINE IN THE FIELD OF CYCLING (U.S. CLS. 2, 5, 22, 23, 29, 37, 38 AND 50).

FIRST USE 4-19-2004; IN COMMERCE 4-19-2004.
BARBARA A. GOLD, EXAMINING ATTORNEY

SN 85-149,512. BEE INSPIRED, LLC, OKEMOS, MI. FILED 10-11-2010.

BEE INSPIRED

THE MARK CONSISTS OF STANDARD CHARACTERS WITHOUT CLAIM TO ANY PARTICULAR FONT, STYLE, SIZE, OR COLOR.

FOR PAPER PRODUCTS, NAMELY, MULTIPLE PIECES OF PAPER, EACH HAVING AN INDIVIDUAL MOTIVATIONAL AND INSPIRATIONAL MESSAGE IMPRINTED THEREON, SOLD TOGETHER IN A DECORATIVE CONTAINER (U.S. CLS. 2, 5, 22, 23, 29, 37, 38 AND 50).

FIRST USE 11-20-2009; IN COMMERCE 11-20-2009.
ANDREA HACK, EXAMINING ATTORNEY

CLASS 16—(Continued).

SN 85-150,240. JOHNSON, LEE R., KNOXVILLE, TN. FILED 10-12-2010.

MY LIFE FROM ZERO to 101

THE MARK CONSISTS OF STANDARD CHARACTERS WITHOUT CLAIM TO ANY PARTICULAR FONT, STYLE, SIZE, OR COLOR.

FOR BOOK, NAMELY, A COMBINATION SCRAPBOOK AND JOURNAL FOR RECORDING AND DOCUMENTING PERSONAL AND FAMILY HISTORIES (U.S. CLS. 2, 5, 22, 23, 29, 37, 38 AND 50).

RONALD MCMORROW, EXAMINING ATTORNEY

SN 85-163,416. WORLD WRESTLING ENTERTAINMENT, INC., STAMFORD, CT. FILED 10-28-2010.



OWNER OF U.S. REG. NOS. 3,441,496, 3,755,039 AND OTHERS.

NO CLAIM IS MADE TO THE EXCLUSIVE RIGHT TO USE "ASSOCIATION", APART FROM THE MARK AS SHOWN.

THE MARK CONSISTS OF "AMERICAN WRESTLING ASSOCIATION" WRITTEN IN A U-SHAPE, SURROUNDING THE LETTERS "AWA", 5 STYLIZED SUNBURSTS, ALL OF WHICH ARE FEATURED INSIDE A SHIELD-LIKE SHAPED DESIGN.

FOR PAPER HANGTAGS; CARDBOARD HANGTAGS; PACKAGING, NAMELY, BLISTER CARDS, PAPER FOR WRAPPING AND PACKAGING, PAPER POUCHES FOR PACKAGING, PLASTIC BAGS FOR PACKAGING, PLASTIC BUBBLE PACKS FOR WRAPPING OR PACKAGING; COLLECTOR ALBUMS, NAMELY, FOR STICKER COLLECTABLE CARDS, PHOTO COLLECTABLES; LABELS, NAMELY, PRINTED PAPER LABELS, PRINTED SHIPPING LABELS; RETURN ADDRESS LABELS NOT OF TEXTILE; FOLDERS; PLASTIC BAGS FOR GENERAL USE; PAPER TABLEWARE, NAMELY, PAPER PLACE MATS, PAPER TABLE MATS, PAPER NAPKINS, PAPER TABLE LINENS, PAPER TABLECLOTHS; PAPER LUNCH BAGS; STICKERS; BUMPER STICKERS; WINDOW DECALS; PENS; PENCILS; PENCIL SHARPENERS; PENCIL CASES; CHALK; ERASERS, NAMELY, RUBBER ERASERS, CHALK ERASERS, BLACKBOARD ERASERS; POSTERS; NOTEBOOKS; TRADING CARDS; CALENDARS; PHOTOGRAPHS; FRAMED PICTURES; PHOTOGRAPHIC PRINTS; PICTURES; PHOTO ALBUMS;

CLASS 16—(Continued).

BROCHURES, NEWSLETTERS, MAGAZINES, AND NEWSPAPERS CONCERNING SPORTS ENTERTAINMENT; POSTCARDS; GREETING CARDS; DECALS; TEMPORARY TATTOO TRANSFERS; COLORING BOOKS; CHILDREN'S ACTIVITY BOOKS; SOUVENIR PROGRAMS CONCERNING SPORTS ENTERTAINMENT; BOOKS FEATURING PICTORIAL BIOGRAPHIES; AUTOGRAPH BOOKS; COMIC BOOKS; PICTURE BOOKS; STICKER ALBUMS; BOOK COVERS; PAPER BOOK MARKERS; BOOKPLATES; MEMO PADS; SCRIBBLE PADS; DATE BOOKS; ADDRESS BOOKS; AGENDA BOOKS; RUBBER STAMPS; STAMP PADS; COLLECTIBLE PREPAID TELEPHONE CARDS NOT MAGNETICALLY ENCODED; COLLECTOR STAMPS, NAMELY, COMMEMORATIVE STAMP SHEETS; CUSTOMIZED PERSONAL CHECKS; CHECKBOOK COVERS; PAPER BANNERS; PRINTED PAPER SIGNS FOR DOORS; DRAWING RULERS; LITHOGRAPHS; PAPER PARTY BAGS; STENCILS FOR TRACING DESIGNS ONTO PAPER; PAPER GIFT WRAP; PAPER CAKE DECORATIONS (U.S. CLS. 2, 5, 22, 23, 29, 37, 38 AND 50).

CARRIE GENOVESE, EXAMINING ATTORNEY

SN 85-166,117. THE SWEETEST AFFAIR, LLC, CLARKSBURG, MD. FILED 11-1-2010.



THE MARK CONSISTS OF AN ABSTRACT FLOWER ICON ABOVE THE WORDS "SWEETEST AFFAIR" WITH THE WORD "THE" TO THE LEFT.

FOR DECORATIVE PAPER CENTERPIECES; PAPER PARTY FAVORS (U.S. CLS. 2, 5, 22, 23, 29, 37, 38 AND 50).

FIRST USE 8-1-2010; IN COMMERCE 9-1-2010.

ANN E. SAPPENFIELD, EXAMINING ATTORNEY

SN 85-178,814. OPERATION BASS, INC., BENTON, KY. FILED 11-17-2010.



OWNER OF U.S. REG. NOS. 2,452,208, 2,887,398 AND OTHERS.

NO CLAIM IS MADE TO THE EXCLUSIVE RIGHT TO USE "WALLEYE" AND "PUBLICATION", APART FROM THE MARK AS SHOWN.

THE MARK CONSISTS OF THE WORDS: "WALLEYE AN FLW OUTDOORS PUBLICATION" WITH A HOOK DESIGN OVER THE "W" OF "WALLEYE".

SEC. 2(F) AS TO "OUTDOORS".

FOR MAGAZINES IN THE FIELD OF FISHING (U.S. CLS. 2, 5, 22, 23, 29, 37, 38 AND 50).

FRANK LATTUCA, EXAMINING ATTORNEY

CLASS 16—(Continued).

SN 85-191,674. ROYER, MADELEINE, DBA ITPRETTY, NASHVILLE, TN. FILED 12-6-2010.



THE COLOR(S) BROWN IS/ARE CLAIMED AS A FEATURE OF THE MARK.
THE MARK CONSISTS OF THE WORD "ITPRETTY" AND IS THE COLOR BROWN.
FOR ART PRINTS (U.S. CLS. 2, 5, 22, 23, 29, 37, 38 AND 50).
FIRST USE 11-1-2010; IN COMMERCE 11-1-2010.
WENDY JUN, EXAMINING ATTORNEY

SN 85-202,699. WORLD WRESTLING ENTERTAINMENT, INC., STAMFORD, CT. FILED 12-21-2010.



THE MARK CONSISTS OF STANDARD CHARACTERS WITHOUT CLAIM TO ANY PARTICULAR FONT, STYLE, SIZE, OR COLOR.
OWNER OF U.S. REG. NOS. 1,571,823, 1,884,646 AND 2,702,648.

FOR CARDBOARD AND PAPER HANG TAGS; PACKAGING, NAMELY, BLISTER CARDS; PAPER FOR WRAPPING AND PACKAGING; COLLECTOR ALBUMS, NAMELY, FOR STICKER COLLECTABLE CARDS; STICKERS; STICKER ALBUMS; PHOTO COLLECTABLES; PHOTO ALBUMS; PHOTOGRAPHS; FRAMED PICTURES; LABELS, NAMELY, PRINTED PAPER LABELS; FOLDERS; PENS; PENCILS; NOTEBOOKS; CALENDARS; TRADING CARDS; CHALKS; POSTCARDS; GREETING CARDS; PICTURES; POSTERS; DECALS; TEMPORARY TATTOO TRANSFERS; BROCHURES, MAGAZINES AND NEWSPAPERS CONCERNING SPORTS ENTERTAINMENT; COLORING BOOKS; CHILDREN'S ACTIVITY BOOKS; SOUVENIR PROGRAMS CONCERNING SPORTS ENTERTAINMENT; BOOKS CONCERNING SPORTS ENTERTAINMENT; BOOKS FEATURING PICTORIAL BIOGRAPHIES; COMIC BOOKS; PICTURE BOOKS; BOOK COVERS; PAPER BOOK MARKERS; MEMO PADS; NOTE PADS; SCRIBBLE PAD; DATE BOOKS; ADDRESS BOOKS; AGENDA BOOKS; PENCIL SHARPENERS; PENCIL CASES; RUBBER STAMPS; STAMP PADS; PAPER BANNERS; PRINTED PAPER SIGNS FOR DOORS; DRAWING RULERS; ERASERS, RUBBER ERASERS; BUMPER STICKERS; WINDOW DECALS; LITHOGRAPHS; PAPER PARTY BAGS; PAPER PARTY FAVORS; STENCILS FOR TRACING DESIGNS ONTO PAPER; PAPER GIFT WRAP; PAPER CAKE DECORATIONS; PLATES OF PAPER OR CARDBOARDS; PAPER (U.S. CLS. 2, 5, 22, 23, 29, 37, 38 AND 50).

FIRST USE 7-29-1988; IN COMMERCE 7-29-1988.
DANNEAN HETZEL, EXAMINING ATTORNEY

CLASS 16—(Continued).

SN 85-205,358. FOOD IN MY HOOD, INC., SAN FRANCISCO, CA. FILED 12-23-2010.



THE MARK CONSISTS OF STANDARD CHARACTERS WITHOUT CLAIM TO ANY PARTICULAR FONT, STYLE, SIZE, OR COLOR.
NO CLAIM IS MADE TO THE EXCLUSIVE RIGHT TO USE "FOOD", APART FROM THE MARK AS SHOWN.
FOR COUPON BOOKS (U.S. CLS. 2, 5, 22, 23, 29, 37, 38 AND 50).
FIRST USE 10-1-2010; IN COMMERCE 12-1-2010.
WILLIAM BRECKENFELD, EXAMINING ATTORNEY

SN 85-208,343. LAKE, TIFFANY, GLENDALE, CA. FILED 12-30-2010.



THE MARK CONSISTS OF THE STYLIZED WORD "STELLETWAL".
FOR SERIES OF FICTION WORKS, NAMELY, NOVELS AND BOOKS (U.S. CLS. 2, 5, 22, 23, 29, 37, 38 AND 50).
FIRST USE 12-16-2010; IN COMMERCE 3-4-2011.
JOHN GARTNER, EXAMINING ATTORNEY

SN 85-209,119. NEBB JACOB C. DBA KEEPSAKE NAMES, ERIE, MI. AND NEBB DIANE C. DBA KEEPSAKE NAMES, ERIE, MI. FILED 1-3-2011.

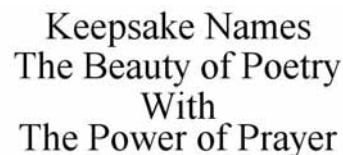

THE MARK CONSISTS OF STANDARD CHARACTERS WITHOUT CLAIM TO ANY PARTICULAR FONT, STYLE, SIZE, OR COLOR.
NO CLAIM IS MADE TO THE EXCLUSIVE RIGHT TO USE "KEEPSAKE", APART FROM THE MARK AS SHOWN.
FOR POEMS AND PRAYERS PRINTED ON PAPER (U.S. CLS. 2, 5, 22, 23, 29, 37, 38 AND 50).
FIRST USE 12-1-1994; IN COMMERCE 12-1-1994.
FRANK LATTUCA, EXAMINING ATTORNEY

CLASS 16—(Continued).

SN 85-212,417. MOUNTAIN WINE CELLARS LLC, DBA MOUNTAIN WINE CELLARS LLC, MIAMI, FL. FILED 1-6-2011.



PRIORITY CLAIMED UNDER SEC. 44(D) ON CHILE APPLICATION NO. 917,057, FILED 9-16-2010.

THE COLOR(S) BLACK, GREY, GOLD. IS/ARE CLAIMED AS A FEATURE OF THE MARK.

THE MARK CONSISTS OF THREE BLACK HORSES RUNNING. THE LETTERS "CABALLO BRAVO" ARE WRITTEN IN GOLD, AND THE DRAWING IS ON A GREY BACKGROUND.

THE ENGLISH TRANSLATION OF "CABALLO BRAVO" IN THE MARK IS "BRAVE HORSE".

FOR (BASED ON USE IN COMMERCE) PRINTED NOVELTY WINE LABELS(BASED ON 1(A) PRIORITY APPLICATION) PRINTED NOVELTY WINE LABELS. THE APPLICATION WAS 44D AND AS THERE IS NO LONGER A REGISTRATION IN A FOREIGN COUNTRY, IT HAS BEEN CHANGED TO 1A AS IT IS ONLY IN THE UNITED STATES (U.S. CLS. 2, 5, 22, 23, 29, 37, 38 AND 50).

FIRST USE 5-1-2010; IN COMMERCE 12-1-2010.
INGA ERVIN, EXAMINING ATTORNEY

SN 85-218,660. KARMASU TECHNOLOGY INC., VANCOUVER, CANADA, FILED 1-15-2011.

BOMBAY BAGS

THE MARK CONSISTS OF STANDARD CHARACTERS WITHOUT CLAIM TO ANY PARTICULAR FONT, STYLE, SIZE, OR COLOR.

OWNER OF CANADA REG. NO. TMA797,434, DATED 5-12-2011, EXPIRES 5-12-2026.

NO CLAIM IS MADE TO THE EXCLUSIVE RIGHT TO USE "BAGS", APART FROM THE MARK AS SHOWN.

FOR STATIONERY, NAMELY, DOCUMENT FOLIOS (U.S. CLS. 2, 5, 22, 23, 29, 37, 38 AND 50).

LINDA M. KING, EXAMINING ATTORNEY

CLASS 16—(Continued).

SN 85-256,229. HARE IN THE GATE PRODUCTIONS, LLC, PORTLAND, OR. FILED 3-2-2011.

BOTANICAPRINTS

THE MARK CONSISTS OF STANDARD CHARACTERS WITHOUT CLAIM TO ANY PARTICULAR FONT, STYLE, SIZE, OR COLOR.

FOR GREETING CARDS (U.S. CLS. 2, 5, 22, 23, 29, 37, 38 AND 50).

FIRST USE 1-1-2011; IN COMMERCE 1-1-2011.
ALLISON SCHRODY, EXAMINING ATTORNEY

SN 85-256,303. THOMASPAUL STUDIO, LLC, NEW YORK, NY. FILED 3-2-2011.

Counterfeit Studio

THE MARK CONSISTS OF STANDARD CHARACTERS WITHOUT CLAIM TO ANY PARTICULAR FONT, STYLE, SIZE, OR COLOR.

NO CLAIM IS MADE TO THE EXCLUSIVE RIGHT TO USE "STUDIO", APART FROM THE MARK AS SHOWN.

FOR STATIONERY, NAMELY, NOTE CARDS, BLANK JOURNALS, NOTEPADS, CALENDARS; DESK ACCESSORIES, NAMELY, PENCIL CUPS AND HOLDERS, FILE FOLDERS, MAGAZINE HOLDERS MADE OF PAPER AND CARDBOARD, LETTER TRAYS, BINDERS, PENCIL CASES, PENCILS, PAPER EXPANDING FILES, FILE BOXES FOR STORAGE OF MAGAZINES, FILE BOXES FOR STORAGE OF BUSINESS AND PERSONAL RECORD (U.S. CLS. 2, 5, 22, 23, 29, 37, 38 AND 50).

FIRST USE 1-1-2009; IN COMMERCE 7-1-2009.
DOMINICK J. SALEMI, EXAMINING ATTORNEY

CLASS 16—(Continued).

SN 85-260,570. CLINICAL DIAGNOSTIC SOLUTIONS, INC., PLANTATION, FL. FILED 3-8-2011.



NO CLAIM IS MADE TO THE EXCLUSIVE RIGHT TO USE "CLINICAL DIAGNOSTIC SOLUTIONS, INC.", APART FROM THE MARK AS SHOWN.

THE MARK CONSISTS OF THE LETTER "C" AND THE LETTER "D" COMBINED TO FORM THE LETTER S WITH THREE SMALL TRIANGLES ALL SUPERIMPOSED ON TWO LARGE TRIANGLES, ALL TO THE LEFT OF THE WORDS "CLINICAL DIAGNOSTIC SOLUTIONS, INC."

FOR NEWSLETTER DEALING WITH IN VITRO DIAGNOSTIC HEMATOLOGY INSTRUMENTS AND REAGENTS; PRODUCT CATALOGS IN THE FIELDS OF PARTICLE STUDY AND ANALYSIS, HEMATOLOGY, CYTOLOGY, INSTRUMENTATION AND RELATED BIOLOGICAL, MEDICAL, CLINICAL, INDUSTRIAL AND APPLICATIONS TECHNOLOGY; CUSTOMER ORIENTED PERIODICALLY ISSUED NEWSLETTER IN THE FIELDS OF PARTICLE STUDY AND ANALYSIS, HEMATOLOGY, CYTOLOGY, INSTRUMENTATION AND RELATED BIOLOGICAL, MEDICAL, CLINICAL, INDUSTRIAL AND APPLICATIONS TECHNOLOGY; PERIODICALLY ISSUED CORPORATE NEWSLETTER DEALING WITH MATTERS OF CORPORATE EMPLOYEE INTEREST IN THE FIELD OF PARTICLE STUDY AND ANALYSIS, HEMATOLOGY, CYTOLOGY, INSTRUMENTATION AND RELATED BIOLOGICAL, MEDICAL, CLINICAL, INDUSTRIAL AND APPLICATIONS TECHNOLOGY, CORPORATE ACTIVITIES AND POLICIES AND EMPLOYEE ACTIVITIES (U.S. CLS. 2, 5, 22, 23, 29, 37, 38 AND 50).

FIRST USE 3-0-1999; IN COMMERCE 6-1-1999.
JOHN SCHUYLER YARD, EXAMINING ATTORNEY

CLASS 16—(Continued).

TURING MACHINE HAVING A RECTANGULAR BODY WITH THE ALPHA-NUMERIC DESIGNATIONS "Q1", "Q2", "Q3", "Q4", "Q5", AND "Q6", EACH WITHIN A CIRCLE AND ARRANGED IN A CIRCULAR PATTERN AROUND AN ARROW SHAPED POINTER; A LIGHT BULB APPEARS ON THE LEFT SIDE; A ROBOTIC ARM HOLDING AN EXCLAMATION MARK APPEARS ON THE RIGHT SIDE; A WHEEL WITH SPOKES APPEARS UNDERNEATH; ABOVE THE MACHINE IS A BANNER WITH THE LETTERS "HMC" AND "CS".

FOR PRINTED EDUCATIONAL MATERIALS IN THE FIELD OF COMPUTER SCIENCE (U.S. CLS. 2, 5, 22, 23, 29, 37, 38 AND 50).
DAVID ELTON, EXAMINING ATTORNEY

SN 85-269,359. AMERICAN COLLEGE OF SPORTS MEDICINE, INC., INDIANAPOLIS, IN. FILED 3-17-2011.

LET'S MOVE HEALTHCARE

THE MARK CONSISTS OF STANDARD CHARACTERS WITHOUT CLAIM TO ANY PARTICULAR FONT, STYLE, SIZE, OR COLOR.

NO CLAIM IS MADE TO THE EXCLUSIVE RIGHT TO USE "HEALTHCARE", APART FROM THE MARK AS SHOWN.

FOR PRINTED MATERIALS IN THE NATURE OF REPORTS, SURVEYS, PAMPHLETS, FLYERS, BROCHURES, INFORMATIONAL CARDS, INFORMATIONAL SHEETS, GUIDES AND FOLDERS, ALL IN THE FIELD OF HEALTHCARE (U.S. CLS. 2, 5, 22, 23, 29, 37, 38 AND 50).
FLORENTINA BLANDU, EXAMINING ATTORNEY

SN 85-264,672. ERLINGER, MICHAEL, CLAREMONT, CA. FILED 3-11-2011.

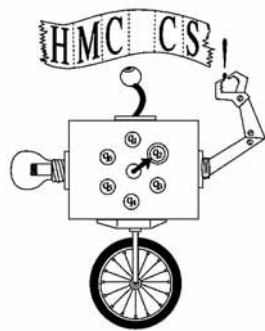

NO CLAIM IS MADE TO THE EXCLUSIVE RIGHT TO USE "CS", APART FROM THE MARK AS SHOWN.
THE MARK CONSISTS OF A CARICATURE OF A

SN 85-270,207. BREAKAWAY MEDIA, LLC, ST. PETERSBURG, FL. FILED 3-17-2011.



NO CLAIM IS MADE TO THE EXCLUSIVE RIGHT TO USE "JOURNAL", APART FROM THE MARK AS SHOWN.

THE MARK CONSISTS OF THE WORDING "THE JOURNAL OF SPECIAL OPERATIONS MEDICINE" TO THE RIGHT OF A DESIGN OF AN ANDROGYNOUS MAN WITH TWO SETS OF ARMS AND LEGS DEPICTING MOTION AND TWO ARROWS FORMING AN "X" OVER HIS MIDSECTION. THE DESIGN IS ENCIRCLED BY THE WORDING "UNCONVENTIONAL WARFARE" CURVING AROUND THE TOP AND "UNCONVENTIONAL MEDICINE" CURVING AROUND THE BOTTOM.

SEC. 2(F).
FOR JOURNALS CONCERNING MEDICINE (U.S. CLS. 2, 5, 22, 23, 29, 37, 38 AND 50).
FIRST USE 3-15-2001; IN COMMERCE 3-15-2001.
MATTHEW MCDOWELL, EXAMINING ATTORNEY

CLASS 16—(Continued).

SN 85-270,509. JOANNE WANAT, ROLLING MEADOWS, IL.
FILED 3-18-2011.

KUPKAKES

THE MARK CONSISTS OF STANDARD CHARACTERS WITHOUT CLAIM TO ANY PARTICULAR FONT, STYLE, SIZE, OR COLOR.

FOR ADDRESS BOOKS; ADHESIVE TAPE DISPENSERS FOR HOUSEHOLD OR STATIONERY USE; ADHESIVES FOR STATIONERY OR HOUSEHOLD PURPOSES; AGENDAS; ANNIVERSARY BOOKS; APPLIQUES IN THE FORM OF DECALS; APPOINTMENT BOOKS; ART ETCHINGS; ART PICTURES; ART PRINTS; ARTISTS' BRUSHES; ARTISTS' PASTELS; ARTS AND CRAFT CLAY KITS; ARTS AND CRAFT PAINT KITS; AUTOGRAPH BOOKS; BABY BOOKS; BANK CHECKS; BINDER CLIPS; BINDERS; BIRTHDAY BOOKS; BLANK JOURNALS; BLANK PAPER NOTEBOOKS; BOOK COVERS; BOOKBINDING MATERIALS; BOOKENDS; BOOKMARKS; BOXES, CARTONS, STORAGE CONTAINERS, AND PACKAGING CONTAINERS MADE OF PAPER OR CARDBOARD; BRAG BOOKS; BUMPER STICKERS; CALENDAR DESK PADS; CALENDAR REFILLS; CALENDARS; CARDS, NAMELY, ANNOUNCEMENT CARDS, BLANK CARDS, BLANK NOTE CARDS, BUSINESS CARDS, CHRISTMAS CARDS, FLASH CARDS, GIFT CARDS, GREETING CARDS, HOLIDAY CARDS, INVITATION CARDS, NOTE CARDS, OCCASION CARDS, PLACE CARDS, PICTURE CARDS, PICTURE POSTCARDS, TRADING CARDS, TELEPHONE CALLING CARDS, NOT MAGNETICALLY ENCODED; CARTOON PRINTS; CARTOON STRIPS; CASES FOR CHECKS; CHALK AND BLACKBOARDS; CHALK ERASERS; CHECKBOOK COVERS; CHILDREN'S ACTIVITY BOOKS; CHILDREN'S BOOKS; CHILDREN'S INTERACTIVE EDUCATIONAL BOOKS; CHILDREN'S STORYBOOKS; CHILDREN'S WALL STICKERS AND MURALS; CHILDREN'S ARTS AND CRAFTS PAPER KITS; COASTERS MADE OF PAPER; COLORING BOOKS; COMIC BOOKS; COMIC STRIPS; COMPOSITION BOOKS; CRAYONS; CREDIT CARDS WITHOUT MAGNETIC CODING; CUSTOM PAINTINGS; DAILY PLANNERS; DATE BOOKS; DECALCOMANIAS; DECALS; DECORATIONS FOR PENCILS; DECORATIVE DECALS FOR VEHICLE WINDOWS; DECORATIVE PAPER BOWS FOR WRAPPING; DECORATIVE PAPER CENTERPIECES; DECORATIVE PENCIL-TOP ORNAMENTS; DECORATIVE STICKERS FOR HELMETS; DESK SETS; DESKTOP ORGANIZERS; DESKTOP PLANNERS; DIARIES; DISPOSABLE NAPKINS; DOCUMENT COVERS; DRIVER'S LICENSE CASES; EMBROIDERY DESIGN PATTERNS; ENGRAVINGS AND THEIR REPRODUCTIONS; ENVELOPES; ERASERS; FABRIC GIFT BAGS; FACIAL TISSUE; FIGURES MADE OF PAPER; FOLDERS; GARBAGE BAGS OF PAPER; GARBAGE BAGS OF PLASTICS; GIFT BAGS; GIFT BOXES; GIFT WRAPPING PAPER; GLUE FOR STATIONERY OR HOUSEHOLD USE; GRAPHIC FINE ART PRINTS; GUEST BOOKS; HALLOWEEN GOODIE BAGS OF PAPER OR PLASTIC; HAND TOWELS OF PAPER; HANDKERCHIEFS OF PAPER; HAT BOXES OF CARDBOARD; ILLUSTRATIONS; IMPRESSION STAMPS; LAP DESKS; LETTER OPENERS; LETTERHEAD PAPER; LITHOGRAPHS; LUNCH BAGS; MAGNETIC BOARDS; MAGNETIC BUMPER STICKERS; MARKERS; MECHANICAL PENCILS; MEMO PADS; MEMORY BOOKS; MURALS; NOTEBOOK DIVIDERS; NOTEBOOK PAPER; NOTEBOOKS; NOTEPADS; NOVELTY IDENTIFICATION CARDS; ORGANIZERS FOR STATIONERY USE; PACKAGING CONTAINERS OF PAPER; PAINT BRUSHES; PAINTING SETS FOR CHILDREN; PAINTINGS; PAPER AND CARDBOARD; PAPER BABY BIBS; PAPER BADGES; PAPER BAGS AND SACKS; PAPER BOWS FOR GIFT WRAP; PAPER CLIPS; PAPER DECORATIVE GARLANDS FOR PARTIES; PAPER LABELS; PAPER PARTY DECORATIONS; PAPER PARTY FAVORS; PAPER PLACE MATS; PAPER RIBBONS; PAPER TABLECLOTHS; PAPERWEIGHTS; PARTY ORNA-

CLASS 16—(Continued).

MENTS OF PAPER; PASSPORT CASES; PASSPORT HOLDERS; PATTERNS FOR MAKING CLOTHES; PEN AND PENCIL CASES AND BOXES; PEN OR PENCIL HOLDERS; PENCIL LEADS; PENCIL SHARPENERS; PENCILS; PENNANTS OF PAPER; PENS; PERSONALIZED COLORING BOOKS FOR CHILDREN; PICTORIAL PRINTS; PICTURE BOOKS; PICTURES; PLASTIC BAGS FOR PACKING; PLASTIC GIFT WRAP; PLASTIC SHOPPING BAGS; POCKET SECRETARIES; POSTERS; PRINTED ART REPRODUCTIONS; PRINTED PAPER LABELS; PRINTED PAPER SIGNS; PRINTED STORIES IN ILLUSTRATED FORM; PRINTS; PROTECTIVE COVERS FOR BOOKS; PROTRACTORS; PUSH PINS; RUBBER BANDS; RUBBER STAMPS; SCENTED DRAWER LINERS; SCRAPBOOK PAGES; SCRAPBOOKS; STAMP PAD INKS; STAPLE REMOVERS; STAPLES; STATIONERY; STENCILS; STICKERS AND STICKER ALBUMS; WEDDING ALBUMS; WRAPPING PAPER; WRITING PADS; IRON-ON TRANSFERS (U.S. CLS. 2, 5, 22, 23, 29, 37, 38 AND 50).

RENEE MCCRAY, EXAMINING ATTORNEY

SN 85-271,157. LEN GRATCH, LEE CENTER, NY. FILED 3-18-2011.



NO CLAIM IS MADE TO THE EXCLUSIVE RIGHT TO USE "NO. 2", APART FROM THE MARK AS SHOWN.

THE MARK CONSISTS OF THE LETTERS "HME" WITH A SUN AND CLOUDS IMAGE ABOVE, AND A PENCIL BELOW AND THE WORDS "NO. 2 HANDWRITING MADE EASY" WITHIN THE PENCIL.

FOR DRY ERASE WRITING BOARDS AND WRITING SURFACES; PLASTIC SHEETS FOR WRITING, PRINTING, AND MARKING; SCHOOL WRITING BOOKS; WRITING PADS; WRITING PAPER; WRITING UTENSILS (U.S. CLS. 2, 5, 22, 23, 29, 37, 38 AND 50).

JENNY PARK, EXAMINING ATTORNEY

CLASS 16—(Continued).

SN 85-271,497. BALL UP, LLC, FORT WORTH, TX. FILED 3-19-2011.

PROSBL

THE MARK CONSISTS OF STANDARD CHARACTERS WITHOUT CLAIM TO ANY PARTICULAR FONT, STYLE, SIZE, OR COLOR.

FOR PUBLICATIONS AND PRINTED MATTER, NAMELY, BASKETBALL TRADING CARDS, DANCE TEAM TRADING CARDS, MASCOT TRADING CARDS, ENTERTAINMENT TRADING CARDS, STICKERS, DECALS, COMMEMORATIVE BASKETBALL STAMPS, COLLECTIBLE CARDBOARD TRADING DISCS, POST CARDS, PAPER PLACE MATS, NOTE CARDS, MEMO PADS, BALL POINT PENS, PENCILS, 3-RING BINDERS, STATIONERY FOLDERS, WIREBOUND NOTEBOOKS, PORTFOLIO NOTEBOOKS, UNMOUNTED AND MOUNTED PHOTOGRAPHS, POSTERS, CALENDARS, BUMPER STICKERS, BOOK COVERS, WRAPPING PAPER, CHILDREN'S ACTIVITY BOOKS, STATISTICAL BOOKS, GUIDE BOOKS AND REFERENCE BOOKS FOR BASKETBALL, MAGAZINES IN THE FIELD OF BASKETBALL, COMMEMORATIVE GAME PROGRAMS, PAPER PENNANTS, STATIONERY, STATIONERY-TYPE PORTFOLIOS, AND STATISTICAL SHEETS FOR BASKETBALL TOPICS, NEWSLETTERS AND PAMPHLETS IN THE FIELD OF BASKETBALL FOR DISTRIBUTION TO THE TELEVISION AND RADIO MEDIA (U.S. CLS. 2, 5, 22, 23, 29, 37, 38 AND 50).

ROBIN CHOSID, EXAMINING ATTORNEY

SN 85-273,414. PATRICIA J. HAYS, LITTLE ROCK, AR. FILED 3-22-2011.

MOMACLE

THE MARK CONSISTS OF STANDARD CHARACTERS WITHOUT CLAIM TO ANY PARTICULAR FONT, STYLE, SIZE, OR COLOR.

FOR NOTEBOOKS, NOTEBOOK DIVIDERS, NOTEPADS, NOTE CARDS, STATIONERY, INK PENS, PENCILS, COLORING BOOKS, CALENDARS, SCRAPBOOK ALBUMS, PHOTOGRAPH ALBUMS, PRINTED TEACHING MATERIALS IN THE FIELD OF EDUCATION AND SPECIAL EDUCATION, PRINTED EDUCATIONAL MATERIALS IN THE FIELD OF EDUCATION AND SPECIAL EDUCATION LAW (U.S. CLS. 2, 5, 22, 23, 29, 37, 38 AND 50).

TINA MAI, EXAMINING ATTORNEY

CLASS 16—(Continued).

SN 85-273,685. CONTROL PAPERS COMPANY, INC., CRANFORD, NJ. FILED 3-22-2011.

SAFELOK

THE MARK CONSISTS OF STANDARD CHARACTERS WITHOUT CLAIM TO ANY PARTICULAR FONT, STYLE, SIZE, OR COLOR.

OWNER OF U.S. REG. NOS. 2,160,638, 3,255,808 AND 3,720,973.

FOR PLASTIC SECURITY AND DEPOSIT ENVELOPES AND COURIER ENVELOPES FOR VALUABLE DOCUMENTS, CURRENCY AND OTHER VALUABLE ITEMS (U.S. CLS. 2, 5, 22, 23, 29, 37, 38 AND 50).

FIRST USE 6-22-1998; IN COMMERCE 6-22-1998.
SIMON TENG, EXAMINING ATTORNEY

SN 85-273,794. PHIFER INCORPORATED, TUSCALOOSA, AL. FILED 3-22-2011.

G/P LAPDESK

THE MARK CONSISTS OF STANDARD CHARACTERS WITHOUT CLAIM TO ANY PARTICULAR FONT, STYLE, SIZE, OR COLOR.

NO CLAIM IS MADE TO THE EXCLUSIVE RIGHT TO USE "LAPDESK", APART FROM THE MARK AS SHOWN.

FOR FOLDING LAPDESKS (U.S. CLS. 2, 5, 22, 23, 29, 37, 38 AND 50).

FIRST USE 12-1-2010; IN COMMERCE 12-1-2010.
MATTHEW MCDOWELL, EXAMINING ATTORNEY

SN 85-274,494. CENTRILL MEDIA CORPORATION, ALBUQUERQUE, NM. FILED 3-23-2011.

Faces of New Mexico

THE MARK CONSISTS OF STANDARD CHARACTERS WITHOUT CLAIM TO ANY PARTICULAR FONT, STYLE, SIZE, OR COLOR.

NO CLAIM IS MADE TO THE EXCLUSIVE RIGHT TO USE "NEW MEXICO", APART FROM THE MARK AS SHOWN.

FOR ART PICTURES; ART PRINTS ON CANVAS; COFFEE TABLE BOOKS FEATURING PEOPLE OF NEW MEXICO; FRAMED ART PICTURES; GICLEE PRINTS; PHOTOGRAPHIC PRINTS; PHOTOGRAPHS; PHOTOGRAPHS THAT HAVE BEEN COMPUTER MANIPULATED AND ENHANCED TO LOOK LIKE PAINTINGS; PICTORIAL PRINTS; PICTURE BOOKS; PRINTS IN THE NATURE OF PHOTOGRAPHS (U.S. CLS. 2, 5, 22, 23, 29, 37, 38 AND 50).

FIRST USE 6-1-2010; IN COMMERCE 11-21-2010.
WILLIAM ROSSMAN, EXAMINING ATTORNEY

CLASS 16—(Continued).

SN 85-275,534. SENIORQUEST PUBLISHING, LLC, DBA SENIORQUEST, KANSAS CITY, MO. FILED 3-24-2011.

Kansas City SeniorLife

THE MARK CONSISTS OF STANDARD CHARACTERS WITHOUT CLAIM TO ANY PARTICULAR FONT, STYLE, SIZE, OR COLOR.

NO CLAIM IS MADE TO THE EXCLUSIVE RIGHT TO USE "KANSAS CITY", APART FROM THE MARK AS SHOWN.

FOR NEWSLETTERS IN THE FIELD OF SENIOR LIVING AND LIFESTYLES (U.S. CLS. 2, 5, 22, 23, 29, 37, 38 AND 50).

FIRST USE 12-5-2010; IN COMMERCE 12-5-2010.
JAY FLOWERS, EXAMINING ATTORNEY

SN 85-276,033. KATY INDEPENDENT SCHOOL DISTRICT, KATY, TX. FILED 3-24-2011.

ALARMS AT SCHOOL

THE MARK CONSISTS OF STANDARD CHARACTERS WITHOUT CLAIM TO ANY PARTICULAR FONT, STYLE, SIZE, OR COLOR.

FOR PACKAGED KITS COMPRISING PRINTED INSTRUCTIONAL, EDUCATIONAL, AND TEACHING MATERIALS FOR EDUCATIONAL ACTIVITIES IN THE FIELD OF SAFETY (U.S. CLS. 2, 5, 22, 23, 29, 37, 38 AND 50).

FIRST USE 6-19-2009; IN COMMERCE 6-19-2009.
MARK PILARO, EXAMINING ATTORNEY

SN 85-277,393. WINTERBORNE, INC., CHATSWORTH, CA. FILED 3-25-2011.



OWNER OF U.S. REG. NOS. 3,011,122 AND 3,017,636.
NO CLAIM IS MADE TO THE EXCLUSIVE RIGHT TO USE "INCORPORATED", APART FROM THE MARK AS SHOWN.

THE MARK CONSISTS OF THE STYLIZED WORDING "WINTERBORNE INCORPORATED".

FOR CARDBOARD PACKAGING; DISPLAY CARDS PRIMARILY COMPOSED OF CARDBOARD (U.S. CLS. 2, 5, 22, 23, 29, 37, 38 AND 50).

FIRST USE 1-0-1999; IN COMMERCE 1-0-1999.
KELLEY WELLS, EXAMINING ATTORNEY

CLASS 16—(Continued).

SN 85-277,542. MISSION INFORMATION RESOURCES, INC., LANCASTER, NH. FILED 3-25-2011.



NO CLAIM IS MADE TO THE EXCLUSIVE RIGHT TO USE "MISSION INFORMATION RESOURCES" OR "EST 1999", APART FROM THE MARK AS SHOWN.

THE MARK CONSISTS OF AN OUTER MULTI-BORDERED RING WITH THE WORDS "MISSION INFORMATION RESOURCES" PRINTED THEREIN. THE WORDS "MISSION" AND "INFORMATION" ARE SEPARATED BY A DOT. THE WORDS "INFORMATION" AND "RESOURCES" ARE SIMILARLY SEPARATED BY A DOT. TWO SMALL BRANCHES WITH LEAVES AND ACORNS ARE SHOWN AT THE BOTTOM OF THE OUTER RING, SEPARATED BY THE WORDS "EST 1999". THE OUTER RING SURROUNDS A MULTI-BORDERED INNER CIRCLE WHICH SHOWS A CASTLE WITH ARROW SHAFTS WITH ARROW HEADS EXTENDING FROM THE BOTTOM AND ARROW SHAFTS WITH ARROW FLETCHING EXTENDING FROM THE TOP. A WAVY BANNER WITH THE WORDS "A VERBIS AD VERBERA" PRINTED ON THE BANNER IS SEEN BEHIND THE CASTLE. THE WORDS "A VERBIS" ARE ON THE LEFT SIDE OF THE CASTLE AND THE WORDS "AD VERBERA" ARE ON THE RIGHT SIDE OF THE CASTLE. A FIVE POINT STAR IS IN THE CASTLE'S WINDOW AND A SWORD IS IN THE CASTLE'S DOORWAY.

THE ENGLISH TRANSLATION OF "A VERBIS AD VERBERA" IN THE MARK IS "FROM WORDS TO BLOWS".

FOR MANUALS IN THE FIELD OF COMBAT, TACTICAL, LOGISTICAL AND/OR RESCUE OPERATIONS (U.S. CLS. 2, 5, 22, 23, 29, 37, 38 AND 50).

FIRST USE 1-15-2008; IN COMMERCE 6-18-2008.
ELLEN B. AWRICH, EXAMINING ATTORNEY

SN 85-277,872. HAMMERLE, RICK, CHATSWORTH, CA. FILED 3-26-2011.

internet
simplify your ^life

THE MARK CONSISTS OF SCRIPT FOR THE WORDS "SIMPLIFY", "YOUR", AND "LIFE". A HANDWRITING SCRIPT FOR "INTERNET", WHICH IS INSERTED ABOVE THE "I" AND THE OTHER WORDS.

FOR BLANK PAPER NOTEBOOKS (U.S. CLS. 2, 5, 22, 23, 29, 37, 38 AND 50).

JESSICA A. POWERS, EXAMINING ATTORNEY

CLASS 16—(Continued).

SN 85-278,256. HENSCHEL, THOMAS, VENTURA, CA.
FILED 3-28-2011.

Ruinedlands Role-Playing Game

THE MARK CONSISTS OF STANDARD CHARACTERS WITHOUT CLAIM TO ANY PARTICULAR FONT, STYLE, SIZE, OR COLOR.

NO CLAIM IS MADE TO THE EXCLUSIVE RIGHT TO USE "ROLE-PLAYING GAME", APART FROM THE MARK AS SHOWN.

FOR ROLE PLAYING GAME EQUIPMENT IN THE NATURE OF GAME BOOK MANUALS (U.S. CLS. 2, 5, 22, 23, 29, 37, 38 AND 50).

RUSS HERMAN, EXAMINING ATTORNEY

SN 85-278,581. STALLINGS, ROBERT M., HOUSTON, TX.
AND YATES, STEVE W., CONROE, TX. FILED 3-28-2011.

Just Drive; it's not a race.

THE MARK CONSISTS OF STANDARD CHARACTERS WITHOUT CLAIM TO ANY PARTICULAR FONT, STYLE, SIZE, OR COLOR.

FOR BUMPER STICKERS (U.S. CLS. 2, 5, 22, 23, 29, 37, 38 AND 50).

ZACHARY BELLO, EXAMINING ATTORNEY

SN 85-279,009. ASSOCIATION OF PERFORMING ARTS
PRESENTERS, WASHINGTON, DC. FILED 3-28-2011.

INSIDE ARTS

THE MARK CONSISTS OF STANDARD CHARACTERS WITHOUT CLAIM TO ANY PARTICULAR FONT, STYLE, SIZE, OR COLOR.

OWNER OF U.S. REG. NO. 1,638,370.

NO CLAIM IS MADE TO THE EXCLUSIVE RIGHT TO USE "ARTS", APART FROM THE MARK AS SHOWN.

FOR MAGAZINES FEATURING THE PERFORMING ARTS (U.S. CLS. 2, 5, 22, 23, 29, 37, 38 AND 50).

FIRST USE 3-5-1990; IN COMMERCE 3-5-1990.

ROBIN CHOSID, EXAMINING ATTORNEY

CLASS 16—(Continued).

SN 85-279,192. PRECIOUS MOMENTS, INCORPORATED,
ROLLING MEADOWS, IL. FILED 3-28-2011.

STINK BUGS

THE MARK CONSISTS OF STANDARD CHARACTERS WITHOUT CLAIM TO ANY PARTICULAR FONT, STYLE, SIZE, OR COLOR.

FOR ADDRESS BOOKS; ADDRESS LABELS; ADHESIVE BANDS FOR STATIONERY OR HOUSEHOLD PURPOSES; ADHESIVE NOTE PADS; ADHESIVE TAPE DISPENSERS FOR HOUSEHOLD OR STATIONERY USE; ADHESIVES FOR STATIONERY OR HOUSEHOLD PURPOSES; AGENDAS; ALBUMS FOR STICKERS; ANNI-VERSARY BOOKS; ART PICTURES; ART PRINTS; ARTISTS' BRUSHES; ARTISTS' PASTELS; ARTISTS' PENCILS; ARTS AND CRAFT CLAY KITS; ARTS AND CRAFT PAINT KITS; AUTOGRAPH BOOKS; BABIES' DIAPERS OF PAPER; BABY BOOKS; BANK CHECKS; BANNERS OF PAPER; BIBLES; BIBS OF PAPER; BINDER CLIPS; BINDERS; BIRTHDAY BOOKS; BLANK JOURNALS; BOOKBINDING MATERIALS; BOOKENDS; BOOKMARKS; BOXES, CARTONS, STORAGE CONTAINERS, AND PACKAGING CONTAINERS MADE OF PAPER OR CARDBOARD; BRAG BOOKS; BUMPER STICKERS; CALENDAR DESK PADS; CALENDAR REFILLS; CALENDARS; CARDBOARD CAKE BOXES; CARDS, NAMELY, ANNOUNCEMENT CARDS, BLANK CARDS, BLANK NOTE CARDS, BUSINESS CARDS, CHRISTMAS CARDS, FLASH CARDS, GIFT CARDS, GREETING CARDS, HOLIDAY CARDS, INVITATION CARDS, NOTE CARDS, OCCASION CARDS, PLACE CARDS, PICTURE CARDS, PICTURE POSTCARDS, TRADING CARDS, TELEPHONE CALLING CARDS, NOT MAGNETICALLY ENCODED; CARTOON PRINTS; CARTOON STRIPS; CASES FOR CHECKS; CHALK AND CHALKBOARDS; CHALK ERASERS; CHAPLETS (ROSARIES); CHECKBOOK COVERS; CHILDREN'S ACTIVITY BOOKS; CHILDREN'S BOOKS; CHILDREN'S INTERACTIVE EDUCATIONAL BOOKS; CHILDREN'S STORYBOOKS; CHILDREN'S WALL STICKERS AND MURALS; CHILDREN'S ARTS AND CRAFTS PAPER KITS; CLIP BOARDS; COASTERS MADE OF PAPER; COMIC BOOKS; COMIC STRIPS; COMPOSITION BOOKS; COOK BOOKS; COOKBOOK HOLDERS; CRAYONS; CROSSWORD PUZZLES; DAILY PLANNERS; DATE BOOKS; DAY PLANNERS; DECALCOMANIAS; DECALS; DECORATIONS FOR PENCILS; DECORATIVE DECALS FOR VEHICLE WINDOWS; DECORATIVE PAPER BOWS FOR WRAPPING; DECORATIVE PAPER CENTERPIECES; DECORATIVE PENCIL-TOP ORNAMENTS; DECORATIVE STICKERS FOR HELMETS; DESK SETS; DESK STANDS AND HOLDERS FOR PENS, PENCILS, AND INK; DESKTOP BUSINESS CARD HOLDERS; DESKTOP ORGANIZERS; DIARIES; DICTIONARIES; DISPOSABLE NAPKINS; DISPOSABLE TRAINING PANTS; DOCUMENT COVERS; DRAWINGS; DRIVER'S LICENSE CASES; DRIVER'S LICENSE HOLDERS; DRY TRANSFER CHARACTERS; EASELS; EMBROIDERY DESIGN PATTERNS; ENGAGEMENT BOOKS; ENVELOPES; ERASERS; FABRIC GIFT BAGS; FACIAL TISSUE; FIGURES MADE OF PAPER; FLAGS AND PENNANTS OF PAPER; FOLDERS; FRAMED ART PICTURES; FRAMED ART PRINTS; GARBAGE BAGS OF PAPER; GARBAGE BAGS OF PLASTICS; GIFT BAGS; GIFT BOXES; GLUE FOR STATIONERY OR HOUSEHOLD PURPOSES; GLUE STICKS FOR STATIONERY OR HOUSEHOLD USE; GUEST BOOKS; HALLOWEEN GOODIE BAGS OF PAPER OR PLASTIC; HAND TOWELS OF PAPER; HANDKERCHIEFS OF PAPER; HAT BOXES OF CARDBOARD; HAT BOXES OF PAPER; ILLUSTRATIONS; IMPRESSION STAMPS; LAP DESKS; LETTER OPENERS; LETTERHEAD PAPER; LITHOGRAPHS; LUNCH BAGS; MAGNETIC BOARDS; MAGNETIC BUMPER STICKERS; MARKERS; MEMO PADS; MEMORY BOOKS; MODELING CLAY; MODELING COMPOUNDS; MOISTURE-PROOF CELLOPHANE PAPER; MURALS; NOTEBOOK DIVIDERS; NOTEBOOKS; NOTEPADS; PAINT BRUSHES; PAINTING SETS

CLASS 16—(Continued).

FOR CHILDREN; PAINTINGS; PAINTINGS IN MIXED MEDIA; PAPER AND CARDBOARD; PAPER BABY BIBS; PAPER BADGES; PAPER BAGS AND SACKS; PAPER BOWS FOR GIFT WRAP; PAPER CAKE DECORATIONS; PAPER CLIP HOLDERS; PAPER CLIPS; PAPER DECORATIVE GARLANDS FOR PARTIES; PAPER NAPKINS; PAPER PARTY DECORATIONS; PAPER PARTY FAVORS; PAPER PLACE MATS; PAPER RIBBONS; PAPER TABLECLOTHS; PAPERWEIGHTS; PARTY GOODIE BAGS OF PAPER OR PLASTIC; PARTY ORNAMENTS OF PAPER; PASSPORT CASES; PASSPORT HOLDERS; PATTERNS FOR MAKING CLOTHES; PEN AND PENCIL CASES AND BOXES; PENCIL LEADS; PENCILS; PENS; PERSONAL ORGANIZERS; PHOTOGRAPH ALBUMS; PICTORIAL PRINTS; PICTURE BOOKS; PICTURES; PLASTIC BAGS FOR PACKING; PLASTIC GIFT WRAP; PLASTIC SHOPPING BAGS; POCKET SECRETARIES; POSTERS; PRINTED ART REPRODUCTIONS; PRINTED AWARD CERTIFICATES; PRINTED CHILDREN'S COLORING PAGES; PRINTED PAPER LABELS; PRINTED PAPER SIGNS; PRINTS; PROTECTIVE COVERS FOR BOOKS; PROTRACTORS; PUSH PINS; RECIPE BOOKS; RUBBER BANDS; RUBBER STAMPS; SCENTED DRAWER LINERS; SCRAPBOOK PAGES; SCRAPBOOKS; SERIES OF FICTION BOOKS; STAMP PAD INKS; STAPLE REMOVERS; STAPLERS; STAPLES; STATIONERY; STENCILS; STICK-ON WHITEBOARDS AND DRY-ERASE BOARDS; STICKERS AND STICKER ALBUMS; STORY BOOKS; TEMPORARY TATTOOS; WEDDING ALBUMS; WRAPPING PAPER; WRITING PADS (U.S. CLS. 2, 5, 22, 23, 29, 37, 38 AND 50).

JUDITH HELFMAN, EXAMINING ATTORNEY

SN 85-280,425. BIRGEOGLU, OSMAN, PHOENIX, AZ. FILED 3-29-2011.

Search for God Series

THE MARK CONSISTS OF STANDARD CHARACTERS WITHOUT CLAIM TO ANY PARTICULAR FONT, STYLE, SIZE, OR COLOR.

NO CLAIM IS MADE TO THE EXCLUSIVE RIGHT TO USE "SERIES", APART FROM THE MARK AS SHOWN.

FOR PRINTED MATTER, NAMELY, BOOKS IN THE FIELD OF FAITH AND RELIGION (U.S. CLS. 2, 5, 22, 23, 29, 37, 38 AND 50).

FIRST USE 7-15-2002; IN COMMERCE 7-15-2002.
AMY HELLA, EXAMINING ATTORNEY

SN 85-283,471. BRIGNOL, FRANTZ, TAVARES, FL. FILED 4-1-2011.

wonder comics

THE MARK CONSISTS OF STANDARD CHARACTERS WITHOUT CLAIM TO ANY PARTICULAR FONT, STYLE, SIZE, OR COLOR.

NO CLAIM IS MADE TO THE EXCLUSIVE RIGHT TO USE "COMICS", APART FROM THE MARK AS SHOWN.

FOR COMIC BOOKS (U.S. CLS. 2, 5, 22, 23, 29, 37, 38 AND 50).

JAY FLOWERS, EXAMINING ATTORNEY

CLASS 16—(Continued).

SN 85-285,898. ENRIQUEZ, MICHAEL, PALOS VERDES ESTATES, CA. FILED 4-4-2011.



THE STIPPLING IS FOR SHADING PURPOSES ONLY.

THE MARK CONSISTS OF A HALF CIRCLE OF SEVEN CHILDREN HOLDING HANDS AROUND A GLOBE. SEVERAL CONTINENTS ARE DISPLAYED ON THE GLOBE. THE WORDS "HELPING BUILD A SOLID FOUNDATION FOR TOMORROW" ARCH ACROSS THE TOP OF THE GLOBE, AND THE WORDS "THE T.R.U.C.E. PROJECT" CURVE AROUND THE BOTTOM OF THE GLOBE.

FOR EDUCATIONAL PUBLICATIONS, NAMELY, EDUCATIONAL ACTIVITY CARDS, WORKBOOKS, TEXTBOOKS, ACTIVITY BOOKS, STORY BOOKS, TEACHER GUIDES, MANUALS, POSTERS AND EDUCATIONAL BOOKLETS IN THE FIELD OF PSYCHOEDUCATION, THERAPY, COUNSELING, MEDIATION, PEACE-BUILDING, AND CONFLICT RESOLUTION (U.S. CLS. 2, 5, 22, 23, 29, 37, 38 AND 50).

BRIDGETT SMITH, EXAMINING ATTORNEY

SN 85-286,080. SHANE'S INSPIRATION, VAN NUYS, CA. FILED 4-5-2011.

INCLUSION LUNCHBOX

THE MARK CONSISTS OF STANDARD CHARACTERS WITHOUT CLAIM TO ANY PARTICULAR FONT, STYLE, SIZE, OR COLOR.

FOR PRINTED EDUCATIONAL MATERIALS IN THE FIELD OF INTEGRATION OF CHILDREN OF ALL ABILITY LEVELS IN A UNIVERSALLY ACCESSIBLE PLAYGROUND ENVIRONMENT AND THE FACILITATION OF UNDERSTANDING AMONG CHILDREN OF ALL ABILITY LEVELS (U.S. CLS. 2, 5, 22, 23, 29, 37, 38 AND 50).

MARGERY A. TIERNEY, EXAMINING ATTORNEY

CLASS 16—(Continued).

SN 85-286,276. TOMASI, TIMOTHY J., AKA TOMASI, TJ, PORT SAINT LUCIE, FL. FILED 4-5-2011.

YOUR BRAIN ON GOLF

THE MARK CONSISTS OF STANDARD CHARACTERS WITHOUT CLAIM TO ANY PARTICULAR FONT, STYLE, SIZE, OR COLOR.

NO CLAIM IS MADE TO THE EXCLUSIVE RIGHT TO USE "GOLF", APART FROM THE MARK AS SHOWN.

FOR EDUCATIONAL PUBLICATIONS, NAMELY, BOOKS, HAND-OUTS, WORKBOOKS, JOURNALS, PLAYBOOKS, WORKSHEETS AND CARDS IN THE FIELD OF RIGHT-BRAIN FITNESS (U.S. CLS. 2, 5, 22, 23, 29, 37, 38 AND 50).

AMY HELLA, EXAMINING ATTORNEY

SN 85-288,997. LIVE NATION WORLDWIDE, INC., BEVERLY HILLS, CA. FILED 4-7-2011.

ELECTRONIC NATION

THE MARK CONSISTS OF STANDARD CHARACTERS WITHOUT CLAIM TO ANY PARTICULAR FONT, STYLE, SIZE, OR COLOR.

FOR PRINTED MATTER, NAMELY, CALENDARS, POSTCARDS, POSTERS, STICKERS, DECALS, NOTE CARDS, NOTEPADS, PRINTED TICKETS (U.S. CLS. 2, 5, 22, 23, 29, 37, 38 AND 50).

DAVID HOFFMAN, EXAMINING ATTORNEY

SN 85-289,722. RISING PHOENIX ENTERPRISES, INC., BEVERLY HILLS, CA. FILED 4-8-2011.

YOUR LIFE DOES NOT HAVE TO BE A SOAP OPERA

THE MARK CONSISTS OF STANDARD CHARACTERS WITHOUT CLAIM TO ANY PARTICULAR FONT, STYLE, SIZE, OR COLOR.

FOR A SERIES OF BOOKS AND WRITTEN ARTICLES IN THE FIELD OF SELF-HELP, SPIRITUALITY, AND MOTIVATIONAL TOPICS; BOOKS IN THE FIELD OF SELF-HELP, SPIRITUALITY, AND MOTIVATIONAL TOPICS; EDUCATIONAL BOOKS FEATURING SELF-HELP, SPIRITUALITY, AND MOTIVATIONAL TOPICS; SERIES OF NON-FICTION BOOKS IN THE FIELD OF SELF-HELP, SPIRITUALITY, AND MOTIVATIONAL TOPICS (U.S. CLS. 2, 5, 22, 23, 29, 37, 38 AND 50).

GENE MACIOL, EXAMINING ATTORNEY

CLASS 16—(Continued).

SN 85-289,787. WILSON, DAVID, PORTLAND, OR. FILED 4-8-2011.

THE BOOGIES

THE MARK CONSISTS OF STANDARD CHARACTERS WITHOUT CLAIM TO ANY PARTICULAR FONT, STYLE, SIZE, OR COLOR.

FOR SERIES OF CHILDREN'S BOOKS (U.S. CLS. 2, 5, 22, 23, 29, 37, 38 AND 50).

GENE MACIOL, EXAMINING ATTORNEY

SN 85-290,990. AMRON, ALAN, MIAMI BEACH, FL. FILED 4-9-2011.

HOW NOT TO

THE MARK CONSISTS OF STANDARD CHARACTERS WITHOUT CLAIM TO ANY PARTICULAR FONT, STYLE, SIZE, OR COLOR.

FOR A SERIES OF BOOKS AND WRITTEN ARTICLES IN THE FIELD OF EXPERIENCES ACQUIRED IN LIFE, A BUSINESS, ENTERTAINMENT, A TRADE, OR THE LAW (U.S. CLS. 2, 5, 22, 23, 29, 37, 38 AND 50).

COURTNEY ALVAREZ, EXAMINING ATTORNEY

SN 85-291,282. A SLICE IN TIME, LA VERNE, CA. FILED 4-11-2011.

A SLICE IN TIME

THE MARK CONSISTS OF STANDARD CHARACTERS WITHOUT CLAIM TO ANY PARTICULAR FONT, STYLE, SIZE, OR COLOR.

FOR PAPER AND GOODS MADE FROM PAPER, NAMELY, HISTORICAL ART PRINTS, CRATE LABELS, TRADE CARDS, VINTAGE ANIMAL PRINTS, NOTE CARDS, CALENDARS, AND POST CARDS (U.S. CLS. 2, 5, 22, 23, 29, 37, 38 AND 50).

FIRST USE 5-1-2003; IN COMMERCE 5-1-2003.

TIMOTHY FINNEGAN, EXAMINING ATTORNEY

CLASS 16—(Continued).

SN 85-291,411. SALT LIFE HOLDINGS, LLC, JACKSONVILLE, FL. FILED 4-11-2011.

LIVE THE SALT LIFE

THE MARK CONSISTS OF STANDARD CHARACTERS WITHOUT CLAIM TO ANY PARTICULAR FONT, STYLE, SIZE, OR COLOR.

OWNER OF U.S. REG. NOS. 2,959,429, 3,762,960 AND OTHERS.

FOR CALENDARS; COASTERS OF PAPER; COIN HOLDERS; DECALS; STICKERS; MAGAZINES IN THE FIELD OF SPORTS AND OUTDOOR LIFE; MONEY CLIPS; PAPER BANNERS; PAPER NAPKINS; PAPER TABLE CLOTHS; PHOTOGRAPH ALBUMS; POSTERS; STATIONERY (U.S. CLS. 2, 5, 22, 23, 29, 37, 38 AND 50).
JORDAN BAKER, EXAMINING ATTORNEY

SN 85-291,565. GLASER, JAMES, VAIL, AZ. FILED 4-11-2011.

Begin at Thin

THE MARK CONSISTS OF STANDARD CHARACTERS WITHOUT CLAIM TO ANY PARTICULAR FONT, STYLE, SIZE, OR COLOR.

FOR A SERIES OF BOOKS AND WRITTEN ARTICLES IN THE FIELD OF WEIGHT LOSS (U.S. CLS. 2, 5, 22, 23, 29, 37, 38 AND 50).

JUSTINE D. PARKER, EXAMINING ATTORNEY

SN 85-291,568. VILLAR, OCTAVE, LAGUNA HILLS, CA. AND VILLAR, PAUL, LAGUNA HILLS, CA. FILED 4-11-2011.

Ordo Sylvanus

THE MARK CONSISTS OF STANDARD CHARACTERS WITHOUT CLAIM TO ANY PARTICULAR FONT, STYLE, SIZE, OR COLOR.

FOR COMICS; LITHOGRAPHIC WORKS OF ART; NOVELS (U.S. CLS. 2, 5, 22, 23, 29, 37, 38 AND 50).

DAVID H. STINE, EXAMINING ATTORNEY

CLASS 16—(Continued).

SN 85-291,573. ROBERT F. PAWLOWSKI, SUMMIT, NJ. AND TREMAIN L. STANLEY, SUMMIT, NJ. FILED 4-11-2011.

TWO COOL DOODS

THE MARK CONSISTS OF STANDARD CHARACTERS WITHOUT CLAIM TO ANY PARTICULAR FONT, STYLE, SIZE, OR COLOR.

FOR PRINTED MATERIALS, NAMELY, A SERIES OF CHILDRENS BOOKS ABOUT DOGS (U.S. CLS. 2, 5, 22, 23, 29, 37, 38 AND 50).

JUSTINE D. PARKER, EXAMINING ATTORNEY

SN 85-291,621. FALSTREAU, MARYLOU, MORRO BAY, CA. AND FALSTREAU, ALAN, MORRO BAY, CA. FILED 4-11-2011.

Women and the Hourglass

THE MARK CONSISTS OF STANDARD CHARACTERS WITHOUT CLAIM TO ANY PARTICULAR FONT, STYLE, SIZE, OR COLOR.

FOR ART PRINTS; GREETING CARDS; PAINTINGS (U.S. CLS. 2, 5, 22, 23, 29, 37, 38 AND 50).

FIRST USE 6-1-2010; IN COMMERCE 6-1-2010.
ANDREW LEASER, EXAMINING ATTORNEY

SN 85-291,717. MONAHAN, PAUL, STRONGSVILLE, OH. AND MONAHAN, PAULA, STRONGSVILLE, OH. FILED 4-11-2011.

Feed Your Body Not Your Face

THE MARK CONSISTS OF STANDARD CHARACTERS WITHOUT CLAIM TO ANY PARTICULAR FONT, STYLE, SIZE, OR COLOR.

FOR BOOKS IN THE FIELD OF LIVING A HEALTHY LIFESTYLE; WORKBOOKS DIRECTED TO HELP LIVE A HEALTHY LIFESTYLE (U.S. CLS. 2, 5, 22, 23, 29, 37, 38 AND 50).

LINDA E. BLOHM, EXAMINING ATTORNEY

CLASS 16—(Continued).

SN 85-292,056. S. C. JOHNSON & SON, INC., RACINE, WI. FILED 4-11-2011.

GLADE

THE MARK CONSISTS OF STANDARD CHARACTERS WITHOUT CLAIM TO ANY PARTICULAR FONT, STYLE, SIZE, OR COLOR.

OWNER OF U.S. REG. NOS. 642,470, 3,919,899 AND OTHERS.

FOR FRAGRANCES SOLD AS AN INTEGRAL COMPONENT OF TRASH BAGS (U.S. CLS. 2, 5, 22, 23, 29, 37, 38 AND 50).

GRETTA YAO, EXAMINING ATTORNEY

SN 85-292,516. TROIANI, DARIO, CHARLESTON, SC. FILED 4-12-2011.

SANDOKAN

THE MARK CONSISTS OF STANDARD CHARACTERS WITHOUT CLAIM TO ANY PARTICULAR FONT, STYLE, SIZE, OR COLOR.

FOR CHILDREN'S BOOKS; COFFEE TABLE BOOKS FEATURING COMIC, DRAMATIC, ACTION AND ADVENTURE WORKS; COMIC BOOKS; COMIC MAGAZINES; COMIC STRIPS; COMIC STRIPS' COMIC FEATURES; COMICS; GRAPHIC NOVELS; NEWSPAPER COMIC STRIPS; NOVELS; PICTURE BOOKS; POSTERS; POSTERS MADE OF PAPER; PRINTED MATERIALS, NAMELY, NOVELS AND SERIES OF FICTION BOOKS AND SHORT STORIES FEATURING SCENES AND CHARACTERS BASED ON VIDEO GAMES; PRINTED VISUALS IN THE NATURE OF PROMOTIONAL MATERIAL; ROMANCE NOVELS; SERIES OF FICTION BOOKS; SERIES OF FICTION WORKS, NAMELY, NOVELS AND BOOKS (U.S. CLS. 2, 5, 22, 23, 29, 37, 38 AND 50).

RONALD MCMORROW, EXAMINING ATTORNEY

SN 85-292,738. IBASIS, INC., BURLINGTON, MA. FILED 4-12-2011.

LA MAS NUEVA

THE MARK CONSISTS OF STANDARD CHARACTERS WITHOUT CLAIM TO ANY PARTICULAR FONT, STYLE, SIZE, OR COLOR.

THE ENGLISH TRANSLATION OF "LA MAS NUEVA" IN THE MARK IS "THE NEWEST".

FOR PRE-PAID TELEPHONE CALLING CARDS, NOT MAGNETICALLY ENCODED; TELEPHONE CALLING CARDS, NOT MAGNETICALLY ENCODED (U.S. CLS. 2, 5, 22, 23, 29, 37, 38 AND 50).

GIANCARLO CASTRO, EXAMINING ATTORNEY

CLASS 16—(Continued).

SN 85-293,125. BIRMINGHAM, SUSAN E, TINLEY PARK, IL. AND LASKEY, SUSAN A, MCKINNEY, TX. FILED 4-12-2011.

The Reader Keeper

THE MARK CONSISTS OF STANDARD CHARACTERS WITHOUT CLAIM TO ANY PARTICULAR FONT, STYLE, SIZE, OR COLOR.

FOR BOOKMARKERS; BOOKMARKS (U.S. CLS. 2, 5, 22, 23, 29, 37, 38 AND 50).

FIRST USE 2-0-2010; IN COMMERCE 4-5-2011.

TINA MAI, EXAMINING ATTORNEY

SN 85-293,376. MYSTIC PLAYGROUND PRODUCTIONS, SAINT PETERSBURG, FL. FILED 4-12-2011.



NO CLAIM IS MADE TO THE EXCLUSIVE RIGHT TO USE "PRODUCTIONS", APART FROM THE MARK AS SHOWN.

THE MARK CONSISTS OF THE WORDING "MYSTIC PLAYGROUND PRODUCTIONS" CENTERED AND UNDERNEATH A DANCING PONY AND BUTTERFLY.

FOR CHILDREN'S ACTIVITY BOOKS; CHILDREN'S BOOKS; COLORING BOOKS; SERIES OF FICTION BOOKS; SERIES OF FICTION WORKS, NAMELY, NOVELS AND BOOKS; TALKING CHILDREN'S BOOKS (U.S. CLS. 2, 5, 22, 23, 29, 37, 38 AND 50).

ANDREA HACK, EXAMINING ATTORNEY

SN 85-293,860. MACCABI ART LLC, AVENTURA, FL. FILED 4-13-2011.

MACCABI

THE MARK CONSISTS OF STANDARD CHARACTERS WITHOUT CLAIM TO ANY PARTICULAR FONT, STYLE, SIZE, OR COLOR.

FOR TEMPORARY TATTOOS (U.S. CLS. 2, 5, 22, 23, 29, 37, 38 AND 50).

FIRST USE 11-8-2010; IN COMMERCE 11-8-2010.

TEJBIR SINGH, EXAMINING ATTORNEY

CLASS 16—(Continued).

SN 85-294,204. AGC, LLC, CLEVELAND, OH. FILED 4-13-2011.

GIFTS & GOOD WISHES

THE MARK CONSISTS OF STANDARD CHARACTERS WITHOUT CLAIM TO ANY PARTICULAR FONT, STYLE, SIZE, OR COLOR.

NO CLAIM IS MADE TO THE EXCLUSIVE RIGHT TO USE "GIFTS", APART FROM THE MARK AS SHOWN.

FOR GREETING CARDS (U.S. CLS. 2, 5, 22, 23, 29, 37, 38 AND 50).

FIRST USE 7-22-1988; IN COMMERCE 1-31-2010.
COURTNEY ALVAREZ, EXAMINING ATTORNEY

SN 85-294,232. STEPPING STONES MUSEUM FOR CHILDREN, INC., NORWALK, CT. FILED 4-13-2011.

BOOZOO

THE MARK CONSISTS OF STANDARD CHARACTERS WITHOUT CLAIM TO ANY PARTICULAR FONT, STYLE, SIZE, OR COLOR.

FOR ADDRESS BOOKS; ARTISTS' PENCILS; ARTISTS' PENS; BOOK MARKS; BOOK PLATES; CALENDARS; CHILDREN'S BOOKS; COMIC BOOKS; ERASERS; FIGURES MADE OF PAPER; GREETING CARDS; NOTEBOOKS; PAPER GIFT BAGS; PAPER GIFT TAGS; PAPER GIFT WRAP; PAPER NAPKINS; PAPER PARTY BAGS; PAPER PARTY DECORATIONS; PAPER TABLE CLOTHS; PENCILS; PENS; PERSONAL ORGANIZERS; POSTCARDS; POSTERS; PRINTED INVITATIONS; SCHOOL SUPPLY KITS CONTAINING VARIOUS COMBINATIONS OF SELECTED SCHOOL SUPPLIES, NAMELY, WRITING INSTRUMENTS, PENS, PENCILS, MECHANICAL PENCILS, ERASERS, MARKERS, CRAYONS, HIGHLIGHTER PENS, FOLDERS, NOTEBOOKS, PAPER, PROTRACTORS, PAPER CLIPS, PENCIL SHARPENERS, WRITING GRIPS, GLUE AND BOOK MARKS; SERIES OF FICTION BOOKS; STICKER ALBUMS; STICKERS; TEMPORARY TATTOOS; TRADING CARDS (U.S. CLS. 2, 5, 22, 23, 29, 37, 38 AND 50).

JAY BESCH, EXAMINING ATTORNEY

SN 85-294,263. INTEGRATED MANUFACTURING SYSTEMS, INC., TA IMS PAPER GROUP, COCKEYSVILLE, MD. FILED 4-13-2011.

SAVE-A-SHEET

THE MARK CONSISTS OF STANDARD CHARACTERS WITHOUT CLAIM TO ANY PARTICULAR FONT, STYLE, SIZE, OR COLOR.

FOR PAPER TOWELS (U.S. CLS. 2, 5, 22, 23, 29, 37, 38 AND 50).

RONALD MCMORROW, EXAMINING ATTORNEY

CLASS 16—(Continued).

SN 85-295,199. GIBBS M. SMITH, INC., LAYTON, UT. FILED 4-14-2011.

BabyLit

THE MARK CONSISTS OF STANDARD CHARACTERS WITHOUT CLAIM TO ANY PARTICULAR FONT, STYLE, SIZE, OR COLOR.

FOR CHILDREN'S BOOKS (U.S. CLS. 2, 5, 22, 23, 29, 37, 38 AND 50).

FIRST USE 2-15-2011; IN COMMERCE 2-24-2011.
MIDGE BUTLER, EXAMINING ATTORNEY

SN 85-295,650. ELLINGHAUS, JOY, NEW ROCHELLE, NY. FILED 4-14-2011.

NOFO MOFO

THE MARK CONSISTS OF STANDARD CHARACTERS WITHOUT CLAIM TO ANY PARTICULAR FONT, STYLE, SIZE, OR COLOR.

FOR BUMPER STICKERS (U.S. CLS. 2, 5, 22, 23, 29, 37, 38 AND 50).

PATRICIA EVANKO, EXAMINING ATTORNEY

SN 85-295,767. INGRASELINO, ROBERT L., CORAM, NY. AND INGRASELINO, JOSEPH V., RIVERDALE AVE, NY. FILED 4-14-2011.

MY LITTLE MASTERPIECE

THE MARK CONSISTS OF STANDARD CHARACTERS WITHOUT CLAIM TO ANY PARTICULAR FONT, STYLE, SIZE, OR COLOR.

FOR COLORING BOOKS (U.S. CLS. 2, 5, 22, 23, 29, 37, 38 AND 50).

KEVIN CORWIN, EXAMINING ATTORNEY

CLASS 16—(Continued).

SN 85-299,952. CRAYOLA PROPERTIES, INC., EASTON, PA.
FILED 4-20-2011.



OWNER OF U.S. REG. NOS. 1,173,166, 3,177,981 AND OTHERS.

THE MARK CONSISTS OF THE WORD "CRAYOLA" INSIDE A TILTED OVAL WITH THE WORD "CREATIONS" DEPICTED UNDERNEATH IN STYLIZED LETTERING, WHICH CONTAINS A HEART ABOVE THE LETTER "I".

FOR CHILDREN'S CRAFT KITS COMPRISED PRIMARILY OF MARKERS, HIGHLIGHTERS, STENCIL SHEETS, STICKER SHEETS, GLITTER GLUE, COLORED PAPER, PATTERNED PAPER, ERASERS, NOTE PADS, CUTOUTS AND ACTIVITY BOOKLETS (U.S. CLS. 2, 5, 22, 23, 29, 37, 38 AND 50).

TOBY BULLOFF, EXAMINING ATTORNEY

SN 85-306,352. AGC, LLC, CLEVELAND, OH. FILED 4-27-2011.

TURBO BUTTON

THE MARK CONSISTS OF STANDARD CHARACTERS WITHOUT CLAIM TO ANY PARTICULAR FONT, STYLE, SIZE, OR COLOR.

FOR GREETING CARDS (U.S. CLS. 2, 5, 22, 23, 29, 37, 38 AND 50).

COURTNEY ALVAREZ, EXAMINING ATTORNEY

SN 85-313,339. KIMBERLY-CLARK WORLDWIDE, INC., NEENAH, WI. FILED 5-5-2011.

A CLEAN, FRESH TOWEL EVERY TIME

THE MARK CONSISTS OF STANDARD CHARACTERS WITHOUT CLAIM TO ANY PARTICULAR FONT, STYLE, SIZE, OR COLOR.

FOR DISPOSABLE PAPER HAND-TOWELS (U.S. CLS. 2, 5, 22, 23, 29, 37, 38 AND 50).

FIRST USE 2-15-2010; IN COMMERCE 2-15-2010.

JOHN HWANG, EXAMINING ATTORNEY

CLASS 16—(Continued).

SN 85-320,145. IRIS PROPERTIES, INC., NEW YORK, NY.
FILED 5-13-2011.

ME MY OCD AND I

THE MARK CONSISTS OF STANDARD CHARACTERS WITHOUT CLAIM TO ANY PARTICULAR FONT, STYLE, SIZE, OR COLOR.

FOR PUBLICATIONS, NAMELY, A SERIES OF BOOKS, BOOKLETS, WRITTEN ARTICLES, AND MAGAZINES IN THE FIELD OF COGNITIVE BIO-BEHAVIORAL THERAPY; PHOTO COLLECTIONS, DIAGRAMS IN THE NATURE OF VISUAL AIDS, SCHOLARLY ARTICLES, CASE-STUDIES AND RESEARCH REPORTS, ALL IN THE FIELD OF COGNITIVE BIO-BEHAVIORAL THERAPY; MAGAZINES, BOOKS, BOOKLETS THAT CONTAIN PHONOGRAPHIC RECORDINGS AND DVDS SOLD TOGETHER THEREWITH, ALL CONTAINING HISTORICAL, INSTRUCTIONAL AND EDUCATIONAL INFORMATION ABOUT THE FIELD OF COGNITIVE BIO-BEHAVIORAL THERAPY; BLANK AND PARTIALLY PRINTED PAPER LABELS, STICKERS, POST CARDS, STATIONERY, PRINTED INVITATIONS, GIFT BAGS, PAPER AND CARDBOARD GIFT PACKAGING AND ENVELOPES (U.S. CLS. 2, 5, 22, 23, 29, 37, 38 AND 50).

SANDRA BUJA, EXAMINING ATTORNEY

SN 85-324,118. CONTROL PAPERS COMPANY, INC., CRANFORD, NJ. FILED 5-18-2011.

INTERLOK

THE MARK CONSISTS OF STANDARD CHARACTERS WITHOUT CLAIM TO ANY PARTICULAR FONT, STYLE, SIZE, OR COLOR.

OWNER OF U.S. REG. NOS. 2,160,638, 3,255,808 AND 3,720,973.

FOR PLASTIC SECURITY AND DEPOSIT ENVELOPES AND COURIER ENVELOPES FOR VALUABLE DOCUMENTS, CURRENCY AND OTHER VALUABLE ITEMS (U.S. CLS. 2, 5, 22, 23, 29, 37, 38 AND 50).

SIMON TENG, EXAMINING ATTORNEY

SN 85-325,307. SPARTAN BRANDS, INC., NEW YORK, NY.
FILED 5-19-2011.

BLACK & BETTER

THE MARK CONSISTS OF STANDARD CHARACTERS WITHOUT CLAIM TO ANY PARTICULAR FONT, STYLE, SIZE, OR COLOR.

FOR MAGAZINES DIRECTED TO MATTERS OF INTEREST TO THE AFRICAN-AMERICAN COMMUNITY (U.S. CLS. 2, 5, 22, 23, 29, 37, 38 AND 50).

MARK SPARACINO, EXAMINING ATTORNEY

CLASS 16—(Continued).

SN 85-333,592. MARTIN, DAVID, LOUISVILLE, KY. FILED 5-31-2011.

Louisville Lips

THE MARK CONSISTS OF STANDARD CHARACTERS WITHOUT CLAIM TO ANY PARTICULAR FONT, STYLE, SIZE, OR COLOR.

NO CLAIM IS MADE TO THE EXCLUSIVE RIGHT TO USE "LOUISVILLE", APART FROM THE MARK AS SHOWN.

FOR MAGAZINES IN THE FIELD OF FASHION (U.S. CLS. 2, 5, 22, 23, 29, 37, 38 AND 50).

CORY BOONE, EXAMINING ATTORNEY

SN 85-343,136. BARILLA G. E. R. FRATELLI - SOCIETÀ PER AZIONI, PARMA, ITALY, FILED 6-10-2011.

SPAGHETTATA

THE MARK CONSISTS OF STANDARD CHARACTERS WITHOUT CLAIM TO ANY PARTICULAR FONT, STYLE, SIZE, OR COLOR.

FOR PRINTED PUBLICATIONS IN THE NATURE OF MAGAZINES, PAMPHLETS, BROCHURES, AND BOOKS OFFERING RECIPES AND INFORMATION RELATING TO FOOD PRODUCTS, MEALS, DINNERS, AND FAMILY RELATIONSHIPS; PAPER BANNERS, POSTERS, NOTEPADS, CALENDARS, FOLDERS, PENS, PAPER NAPKINS, PAPER PLACEMATS; PAPER STORAGE CONTAINERS FOR PASTA; AND TABLE CLOTHS OF PAPER (U.S. CLS. 2, 5, 22, 23, 29, 37, 38 AND 50).

AISHA CLARKE, EXAMINING ATTORNEY

CLASS 17—RUBBER GOODS

SN 77-783,352. CURWOOD, INC, OSHKOSH, WI. FILED 7-17-2009.



THE MARK CONSISTS OF LEMON SHAPED OBJECT WITH THE WORDS "RESEAL" AND "EZPEEL" IN ARROWS GOING IN DIFFERENT DIRECTIONS.

FOR PLASTIC FLEXIBLE FILM FOR USE IN EASY TO OPEN AND RESEALABLE PACKAGES, SOLD IN BULK TO INDUSTRIAL AND COMMERCIAL MANUFACTURERS (U.S. CLS. 1, 5, 12, 13, 35 AND 50).

FIRST USE 4-17-2009; IN COMMERCE 4-17-2009.

KHANH LE, EXAMINING ATTORNEY

CLASS 17—(Continued).

SN 79-088,060. NORRES SCHLAUCHTECHNIK GMBH & CO. KG, FED REP GERMANY, FILED 10-1-2010.

Pre-PUR

OWNER OF INTERNATIONAL REGISTRATION 0903408 DATED 7-20-2006, EXPIRES 7-20-2016.

FOR NON-METAL FLEXIBLE PIPES; FLEXIBLE PIPES OF PLASTIC; PLASTIC WOUND HOSES, PLASTIC SPIRAL HOSES, PLASTIC SPIRAL HOSES, PLASTIC SPIRAL HOSES WITH SUPPORT COILS, PLASTIC EXTRACTION HOSES, PLASTIC FEED HOSES AND NON-METAL CONNECTION PIECES FOR HOSES FOR USE IN INDUSTRIAL APPLICATION, PLUMBING, VENTILATION AND AGRICULTURE (U.S. CLS. 1, 5, 12, 13, 35 AND 50).

KRISTIN CARLSON, EXAMINING ATTORNEY

SN 85-104,479. HAMMERHEAD INDUSTRIES, INC., VENTURA, CA. FILED 8-10-2010.

GLASS KEEPER

THE MARK CONSISTS OF STANDARD CHARACTERS WITHOUT CLAIM TO ANY PARTICULAR FONT, STYLE, SIZE, OR COLOR.

NO CLAIM IS MADE TO THE EXCLUSIVE RIGHT TO USE "GLASS", APART FROM THE MARK AS SHOWN.

FOR GLASS SAFETY DEVICE, NAMELY, A DEVICE FOR REDUCING SPREAD OF BROKEN GLASS WHEN BREAKING A WINDOW OR WINDSHIELD IN THE NATURE OF ADHESIVE FILM (U.S. CLS. 1, 5, 12, 13, 35 AND 50).

KRISTIN DAHLING, EXAMINING ATTORNEY

SN 85-137,868. NISSIN KOGYO CO., LTD., UEDA-SHI, NAGANO, JAPAN, FILED 9-24-2010.

CELLULATION

THE MARK CONSISTS OF STANDARD CHARACTERS WITHOUT CLAIM TO ANY PARTICULAR FONT, STYLE, SIZE, OR COLOR.

PRIORITY CLAIMED UNDER SEC. 44(D) ON JAPAN APPLICATION NO. 2010-25670, FILED 4-1-2010, REG. NO. 5374826, DATED 12-10-2010, EXPIRES 12-10-2020.

FOR NON-METAL GASKETS FOR COMMERCIAL AND INDUSTRIAL USE; PACKING MATERIALS FOR FORMING SEALS; NON-METAL SEALS FOR COMMERCIAL AND INDUSTRIAL USE, DUST PROOFING SEALANTS, SEALANT COMPOUNDS FOR JOINTS, WATERPROOF SEALANTS; RAW OR SEMI-WORKED RUBBER; RAW OR SEMI-WORKED RUBBER WHICH CONTAINS CARBON NANOTUBES; SYNTHETIC RUBBER (U.S. CLS. 1, 5, 12, 13, 35 AND 50).

ADA HAN, EXAMINING ATTORNEY

CLASS 17—(Continued).

SN 85-289,834. NORTHERN TECHNOLOGIES INTERNATIONAL CORPORATION, BEACHWOOD, OH. FILED 4-8-2011.

FLANGE SAVER

THE MARK CONSISTS OF STANDARD CHARACTERS WITHOUT CLAIM TO ANY PARTICULAR FONT, STYLE, SIZE, OR COLOR.

NO CLAIM IS MADE TO THE EXCLUSIVE RIGHT TO USE "FLANGE", APART FROM THE MARK AS SHOWN.

FOR POLYMERIC FLEXIBLE AND RIGID PACKAGING STRUCTURES AND AIDS, NAMELY, FILMS, FORMS, SHEETING, AND WRAPPING MADE OF PLASTICS AND DESIGNED TO PROTECT INDUSTRIAL AND COMMERCIAL PRODUCTS NAMELY, FLANGES, VALVES, PIPE CONNECTORS, AGAINST CHEMICAL, ELECTROSTATIC, PHYSICAL AND ENVIRONMENTAL DAMAGE DURING USE, TRANSPORTATION AND STORAGE (U.S. CLS. 1, 5, 12, 13, 35 AND 50).

FIRST USE 9-21-2010; IN COMMERCE 9-21-2010.
MICHAEL KEATING, EXAMINING ATTORNEY

SN 85-291,743. STRAIT-FLEX INTERNATIONAL, INC., O'FALLON, MO. FILED 4-11-2011.

PERFECT-90°

THE MARK CONSISTS OF STANDARD CHARACTERS WITHOUT CLAIM TO ANY PARTICULAR FONT, STYLE, SIZE, OR COLOR.

FOR DRYWALL JOINT TAPE (U.S. CLS. 1, 5, 12, 13, 35 AND 50).

FIRST USE 11-29-2010; IN COMMERCE 11-29-2010.
ALLISON SCHRODY, EXAMINING ATTORNEY

SN 85-295,143. STRAIGHT LINE INDUSTRIAL SERVICES, INC., HOUSTON, TX. FILED 4-14-2011.

STRAIGHT-WRAP

THE MARK CONSISTS OF STANDARD CHARACTERS WITHOUT CLAIM TO ANY PARTICULAR FONT, STYLE, SIZE, OR COLOR.

FOR HIGH TEMPERATURE THERMAL INSULATION IN THE FORM OF KNITTED, BRAIDED OR WOVEN FLEXIBLE SLEEVES, TAPES, PADS AND BLANKETS USED TO REDUCE HEAT LOSS, REDUCE EMISSIONS AND TO IMPROVE PERSONNEL SAFETY IN INDUSTRIAL FACILITIES, MANUFACTURING FACILITIES AND COMMERCIAL BUILDINGS (U.S. CLS. 1, 5, 12, 13, 35 AND 50).

JOHN HWANG, EXAMINING ATTORNEY

CLASS 18—LEATHER GOODS

SN 79-089,804. CAMILLE FOURNET, FRANCE, FILED 9-28-2010.

Dédale

THE MARK CONSISTS OF STANDARD CHARACTERS WITHOUT CLAIM TO ANY PARTICULAR FONT, STYLE, SIZE, OR COLOR.

PRIORITY DATE OF 3-30-2010 IS CLAIMED.

OWNER OF INTERNATIONAL REGISTRATION 1057827 DATED 9-28-2010, EXPIRES 9-28-2020.

THE WORDING "DEDALE" HAS NO MEANING IN A FOREIGN LANGUAGE.

FOR LEATHER AND IMITATIONS OF LEATHER, NAMELY, HANDBAGS, EVENING HANDBAGS, TRAVELLING BAG SETS, RUCKSACKS, BEACH BAGS, SHOPPING BAGS, BAGS FOR SPORTS, POCKET WALLETS, DOCUMENT CARRYING CASES, CASES OF LEATHER FOR KEYS AND TELEPHONES; LEATHER CREDIT CARD HOLDERS; ANIMAL SKINS; TRUNKS AND SUITCASES; UMBRELLAS, PARASOLS AND WALKING STICKS; WHIPS, HARNESS AND SADDLERY; WALLETS; PURSES; HANDBAGS, BACKPACKS, WHEELED BAGS; BAGS FOR CLIMBERS IN THE NATURE OF ALL PURPOSE CARRYING BAGS; BAGS FOR CAMPERS; TRAVELING BAGS, BEACH BAGS, SCHOOL BAGS; UNFITTED VANITY CASES; COLLARS OR COVERS FOR ANIMALS; LEATHER SHOPPING BAGS, MESH SHOPPING BAGS, CANVAS SHOPPING BAGS, REUSABLE SHOPPING BAGS, TEXTILE SHOPPING BAGS, WHEELED SHOPPING BAGS, STRING BAGS FOR SHOPPING; LEATHER BAGS FOR MERCHANDISE PACKAGING AND BAGS FOR PACKAGING OF LEATHER (U.S. CLS. 1, 2, 3, 22 AND 41).

DOMINICK J. SALEMI, EXAMINING ATTORNEY

CLASS 18—(Continued).

SN 79-089,855. CAMILLE FOURNET, FRANCE, FILED 9-28-2010.

Thémis

THE MARK CONSISTS OF STANDARD CHARACTERS WITHOUT CLAIM TO ANY PARTICULAR FONT, STYLE, SIZE, OR COLOR.

PRIORITY DATE OF 3-31-2010 IS CLAIMED.
OWNER OF INTERNATIONAL REGISTRATION 1057988 DATED 9-28-2010, EXPIRES 9-28-2020.

THE WORDING "THEMIS" HAS NO MEANING IN A FOREIGN LANGUAGE.

FOR LEATHER AND IMITATIONS OF LEATHER, NAMELY, HANDBAGS, EVENING HANDBAGS, TRAVELLING BAG SETS, RUCKSACKS, BEACH BAGS, SHOPPING BAGS, BAGS FOR SPORTS, POCKET WALLETS, DOCUMENT CARRYING CASES, CASES OF LEATHER FOR KEYS AND TELEPHONES; LEATHER CREDIT CARD HOLDERS; ANIMAL SKINS; TRUNKS AND SUITCASES; UMBRELLAS, PARASOLS AND WALKING STICKS; WHIPS, HARNESS AND SADDLERY; WALLETS; PURSES; HANDBAGS, BACKPACKS, WHEELED BAGS; BAGS FOR CLIMBERS IN THE NATURE OF ALL PURPOSE CARRYING BAGS; BAGS FOR CAMPERS, TRAVELING BAGS, BEACH BAGS, SCHOOL BAGS; UNFITTED VANITY CASES; COLLARS OR COVERS FOR ANIMALS; LEATHER SHOPPING BAGS, MESH SHOPPING BAGS, CANVAS SHOPPING BAGS, REUSABLE SHOPPING BAGS, TEXTILE SHOPPING BAGS, WHEELED SHOPPING BAGS, STRING BAGS FOR SHOPPING; LEATHER BAGS FOR MERCHANDISE PACKAGING AND BAGS FOR PACKAGING OF LEATHER (U.S. CLS. 1, 2, 3, 22 AND 41).

DOMINICK J. SALEMI, EXAMINING ATTORNEY

CLASS 18—(Continued).

SN 79-089,856. CAMILLE FOURNET, FRANCE, FILED 9-28-2010.

Nérée

THE MARK CONSISTS OF STANDARD CHARACTERS WITHOUT CLAIM TO ANY PARTICULAR FONT, STYLE, SIZE, OR COLOR.

PRIORITY DATE OF 3-31-2010 IS CLAIMED.
OWNER OF INTERNATIONAL REGISTRATION 1057989 DATED 9-28-2010, EXPIRES 9-28-2020.

THE WORDING "NERÉE" HAS NO MEANING IN A FOREIGN LANGUAGE.

FOR LEATHER AND IMITATIONS OF LEATHER, NAMELY, HANDBAGS, EVENING HANDBAGS, TRAVELLING BAG SETS, RUCKSACKS, BEACH BAGS, SHOPPING BAGS, BAGS FOR SPORTS, POCKET WALLETS, DOCUMENT CARRYING CASES, CASES OF LEATHER FOR KEYS AND TELEPHONES; LEATHER CREDIT CARD HOLDERS; ANIMAL SKINS; TRUNKS AND SUITCASES; UMBRELLAS, PARASOLS AND WALKING STICKS; WHIPS, HARNESS AND SADDLERY; WALLETS; PURSES; HANDBAGS, BACKPACKS, WHEELED BAGS; BAGS FOR CLIMBERS IN THE NATURE OF ALL PURPOSE CARRYING BAGS; BAGS FOR CAMPERS, TRAVELING BAGS, BEACH BAGS, SCHOOL BAGS; UNFITTED VANITY CASES; COLLARS OR COVERS FOR ANIMALS; LEATHER SHOPPING BAGS, MESH SHOPPING BAGS, CANVAS SHOPPING BAGS, REUSABLE SHOPPING BAGS, TEXTILE SHOPPING BAGS, WHEELED SHOPPING BAGS, STRING BAGS FOR SHOPPING; LEATHER BAGS FOR MERCHANDISE PACKAGING AND BAGS FOR PACKAGING OF LEATHER (U.S. CLS. 1, 2, 3, 22 AND 41).

DOMINICK J. SALEMI, EXAMINING ATTORNEY

SN 85-056,873. SCHAAP, BREANNE, VISALIA, CA. FILED 6-8-2010.

AIRHART

THE MARK CONSISTS OF STANDARD CHARACTERS WITHOUT CLAIM TO ANY PARTICULAR FONT, STYLE, SIZE, OR COLOR.

FOR LEATHER PRODUCTS, NAMELY, LUGGAGE, TRUNKS, SUIT CASES, TRAVEL GEAR, NAMELY, TRAVEL BAGS; LEATHER AND IMITATIONS OF LEATHER, AND GOODS MADE OF THESE MATERIALS AND NOT INCLUDED IN OTHER CLASSES, NAMELY, LEATHER KEY CHAINS; ANIMAL SKINS, HIDES; TRUNKS AND TRAVELLING BAGS; PARASOLS AND WALKING STICKS; WHIPS, HARNESS AND SADDLERY, LUGGAGE, HAT BOX MADE OF LEATHER, SUIT CASE, ALL PURPOSE CARRYING BAG, TRAVEL TRUNK, HAND BAGS, TOILETRY CASES SOLD EMPTY, CARRY ON BAG AND CARRYING CASE FOR CONSUMERS (U.S. CLS. 1, 2, 3, 22 AND 41).

DAVID MURRAY, EXAMINING ATTORNEY

CLASS 18—(Continued).

SN 85-063,870. PAS FOR THE WORLD, DBA CORDOBAGS, JUPITER, FL. FILED 6-15-2010.



THE COLOR(S) BROWN AND TAN IS/ARE CLAIMED AS A FEATURE OF THE MARK.

THE MARK CONSISTS OF THE WORDING "CORDOBAGS" IN STYLIZED TEXT WITH "C" SHAPED LIKE A HANDBAG. THE MARK IS BROWN WITH A TAN BACKGROUND.

FOR HANDCRAFTED WOMEN'S ACCESSORIES, NAMELY, HANDBAGS (U.S. CLS. 1, 2, 3, 22 AND 41). FIRST USE 10-28-2009; IN COMMERCE 10-29-2009.

KEVON CHISOLM, EXAMINING ATTORNEY

SN 85-089,243. MILLY LLC, NEW YORK, NY. FILED 7-21-2010.

OWNER OF U.S. REG. NOS. 3,136,107, 3,820,409 AND OTHERS.

THE NAME(S), PORTRAIT(S), AND/OR SIGNATURE(S) SHOWN IN THE MARK DOES NOT IDENTIFY A PARTICULAR LIVING INDIVIDUAL.

THE MARK CONSISTS OF THE WORD "MILLY" IN SCRIPT FORMAT.

FOR HOBO BAGS, SPORTS BAGS, HANDBAGS, CLUTCHES, PURSES, OVERNIGHT BAGS, TOTE BAGS, GYM BAGS, BEACH BAGS, CARRY-ON BAGS, COSMETIC BAGS SOLD EMPTY (U.S. CLS. 1, 2, 3, 22 AND 41).

FIRST USE 9-30-2001; IN COMMERCE 2-28-2002. MARY I. SPARROW, EXAMINING ATTORNEY

CLASS 18—(Continued).

SN 85-127,032. MITCH SPINACH PRODUCTIONS INC., CORAL SPRINGS, FL. FILED 9-10-2010.

Nutripak

THE MARK CONSISTS OF STANDARD CHARACTERS WITHOUT CLAIM TO ANY PARTICULAR FONT, STYLE, SIZE, OR COLOR.

FOR ALL PURPOSE SPORT BAGS; ALL-PURPOSE ATHLETIC BAGS; ALL-PURPOSE CARRYING BAGS; ALL-PURPOSE REUSABLE CARRYING BAGS; ATHLETIC BAGS; BABY BACKPACKS; BABY CARRYING BAGS; BACKPACKS; BACKPACKS; BACKPACKS WITH ROLLING WHEELS; BACKPACKS, BOOK BAGS, SPORTS BAGS, BUM BAGS, WALLETS AND HANDBAGS; BAGS AND HOLDALLS FOR SPORTS CLOTHING; BAGS FOR CARRYING BABIES' ACCESSORIES; BAGS FOR CLIMBERS IN THE NATURE OF ALL-PURPOSE CARRYING BAGS; BOOK BAGS; CARRY-ALL BAGS; CARRY-ON BAGS; DRAWSTRING BAGS; DUFFEL BAGS; DUFFEL BAGS FOR TRAVEL; DUFFLE BAGS; FLEXIBLE BAGS FOR GARMENTS; FLIGHT BAGS; GARMENT BAGS FOR TRAVEL; GARMENT BAGS FOR TRAVEL MADE OF LEATHER; GENERAL PURPOSE SPORT TROLLEY BAGS; GYM BAGS; HARD-SIDED AND SOFT-SIDED CARRY-ON BAGS AND GYM BAGS; HIKING BAGS; HUNTERS' GAME BAGS; KIT BAGS; KNITTED BAGS, NOT OF PRECIOUS METALS; LEATHER AND IMITATION LEATHER BAGS; LEATHER BAGS AND WALLETS; LEATHER BAGS FOR MERCHANDISE PACKAGING; MILITARY DUFFLE BAGS, GARMENT BAGS FOR TRAVEL, TOTE BAGS, SHOULDER BAGS AND BACKPACKS; POUCHES AND BAGS SOLD EMPTY FOR ATTACHMENT TO BACKPACKS; PROTECTIVE FITTED LINERS FOR BACKPACKS AND LUGGAGE; ROLL BAGS; SACK PACKS, NAMELY, DRAWSTRING BAGS USED AS BACKPACKS; SCHOOLCHILDREN'S BACKPACKS; SMALL BACKPACKS; SPORTS PACKS (U.S. CLS. 1, 2, 3, 22 AND 41).

SUSAN LESLIE DUBOIS, EXAMINING ATTORNEY

SN 85-152,099. PROVO, INC., DBA RVR NECKWEAR, NEW YORK, NY. FILED 10-13-2010.

THE MARK CONSISTS OF A STYLIZED BACKWARDS LETTER "R", A STYLIZED LETTER "V", AND A STYLIZED BACKWARDS "R".

FOR LEATHER AND IMITATION LEATHER PRODUCTS, NAMELY, WALLETS, KEY CHAINS, CHECKBOOK HOLDERS, COIN WALLETS, TRAVEL TIE CASES, TOILETRY CASES SOLD EMPTY, PASSPORT CASES, LUGGAGE TAGS (U.S. CLS. 1, 2, 3, 22 AND 41).

JANICE L. MCMORROW, EXAMINING ATTORNEY

CLASS 18—(Continued).

SN 85-174,794. MJB LICENSING, LLC, WHITE PLAINS, NY.
FILED 11-11-2010.

CLASS 18—(Continued).

SN 85-209,647. LI, ZHI YONG, GUANGZHOU, GUANG-
DONG., CHINA, FILED 1-4-2011.

MARY J. BLIGE

THE MARK CONSISTS OF STANDARD CHARACTERS
WITHOUT CLAIM TO ANY PARTICULAR FONT, STYLE,
SIZE, OR COLOR.

OWNER OF U.S. REG. NOS. 3,404,914 AND 3,448,206.
THE NAME "MARY J. BLIGE" IDENTIFIES A LIVING
INDIVIDUAL WHOSE CONSENT IS OF RECORD.
FOR TOTE BAGS; WALLETS (U.S. CLS. 1, 2, 3, 22 AND
41).

JAMES LOVELACE, EXAMINING ATTORNEY



SN 85-208,921. CHRISTINA JIAN, SAN JOSE, CA. FILED 1-3-
2011.



NO CLAIM IS MADE TO THE EXCLUSIVE RIGHT TO
USE "BAG MANUFACTURING EXPERTS", APART FROM
THE MARK AS SHOWN.

THE COLOR(S) BLACK AND RED IS/ARE CLAIMED AS
A FEATURE OF THE MARK.

THE MARK CONSISTS OF THE STYLIZED TERM "ZOE'S"
IN BLACK WITH THE LETTERS "ZOE" IN UPPER CASE
AND THE LETTER "S" IN LOWER CASE. INSIDE THE
LETTER "O" IS A RED STAR. BELOW ARE THE STYLIZED
TERMS "DIGITAL COOL BAG MANUFACTURING EX-
PERTS" IN BLACK.

FOR FASHION HANDBAGS (U.S. CLS. 1, 2, 3, 22 AND
41).

FIRST USE 8-30-2010; IN COMMERCE 8-30-2010.
DAVID ELTON, EXAMINING ATTORNEY

NO CLAIM IS MADE TO THE EXCLUSIVE RIGHT TO
USE "1995", APART FROM THE MARK AS SHOWN.

THE MARK CONSISTS OF A CROSS APPEARING AT
THE TOP OF THE MARK ABOVE A STYLIZED CROWN.
BENEATH THE CROWN APPEARS A STYLIZED WING
SHAPE DESIGN. THE WORDING "YUNNIKA" APPEARS
BENEATH THE WING DESIGN, FOLLOWED BY THE
NUMBERS OR YEAR 1995.

THE WORDING "YUNNIKA" HAS NO MEANING IN A
FOREIGN LANGUAGE.

FOR ALL-PURPOSE ATHLETIC BAGS; ALL-PURPOSE
CARRYING BAGS; ANIMAL SKINS; ARTIFICIAL FUR;
ATTACHE CASES; BACKPACKS, NAMELY, BOOK
BAGS, SPORTS BAGS, BUM BAGS, WALLETS AND
HANDBAGS; BEACHBAGS; BELT BAGS AND HIP
BAGS; BRIEFCASES; BUSINESS CARD CASES; CANVAS
SHOPPING BAGS; CARD WALLETS; CASES FOR KEYS;
CLUTCH BAGS; COIN PURSES; COSMETIC BAGS SOLD
EMPTY; CREDIT CARD CASES AND HOLDERS; DRY
BAGS; EVENING HANDBAGS; FASHION HANDBAGS;
FUR, NAMELY, SYNTHETIC FUR, FUR PELTS, FURS
SOLD IN BULK AND FIGURES MADE OF FUR; GAR-
MENT BAGS FOR TRAVEL; GYM BAGS; HANDBAGS,
PURSES AND WALLETS; LEATHER AND IMITATION
LEATHER; IMITATION LEATHER KEY CHAINS; KEY
BAGS; KEYCASES; LEATHER BAGS, NAMELY, SUIT-
CASES AND WALLETS; LUGGAGE AND TRUNKS;
MULTI-PURPOSE PURSES; POCHETTES; PURSES AND
WALLETS; SATCHELS; SCHOOLBAGS; SHOULDER
BAGS; TRAVELING BAGS; UMBRELLAS; VALISES;
WALLETS MADE OF LEATHER OR OTHER MATERI-
ALS; WINE CARRYING CASES (U.S. CLS. 1, 2, 3, 22 AND
41).

DARRYL SPRUILL, EXAMINING ATTORNEY

CLASS 18—(Continued).

SN 85-218,666. KARMASU TECHNOLOGY INC., VANCOUVER, CANADA, FILED 1-15-2011.

BOMBAY BAGS

THE MARK CONSISTS OF STANDARD CHARACTERS WITHOUT CLAIM TO ANY PARTICULAR FONT, STYLE, SIZE, OR COLOR.

OWNER OF CANADA REG. NO. TMA797,434, DATED 5-12-2011, EXPIRES 5-12-2026.

NO CLAIM IS MADE TO THE EXCLUSIVE RIGHT TO USE "BAGS", APART FROM THE MARK AS SHOWN.

FOR BACKPACKS; FASHION HANDBAGS; HANDBAGS; REUSABLE SHOPPING BAGS; REUSABLE TEXTILE PRODUCE BAGS TO CARRY PRODUCE FROM GROCERY STORES AND FARMER'S MARKETS; TOTE BAGS; WINE BAGS WITH HANDLES FOR CARRYING OR HOLDING WINE (U.S. CLS. 1, 2, 3, 22 AND 41).

LINDA M. KING, EXAMINING ATTORNEY

CLASS 18—(Continued).

SN 85-269,819. BRIAN KELLY ENTERPRISES, LLC, NOTRE DAME, IN. FILED 3-17-2011.

NEXT MAN IN

THE MARK CONSISTS OF STANDARD CHARACTERS WITHOUT CLAIM TO ANY PARTICULAR FONT, STYLE, SIZE, OR COLOR.

OWNER OF U.S. REG. NO. 3,909,104.

FOR BAGS FOR GENERAL AND SPORT USE, NAMELY, ALL-PURPOSE ATHLETIC BAGS, ALL-PURPOSE CARRYING BAGS, DUFFEL BAGS, BACKPACKS, AND TRAVEL BAGS (U.S. CLS. 1, 2, 3, 22 AND 41).

DOMINICK J. SALEMI, EXAMINING ATTORNEY

SN 85-268,963. BAIK, JONAS INHO, LOS ANGELES, CA. FILED 3-16-2011.

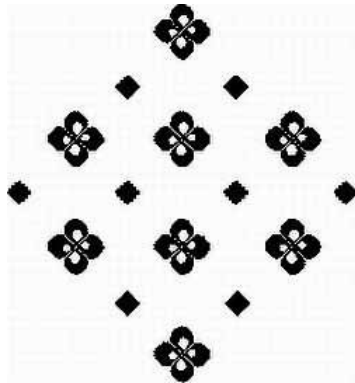

THE MARK CONSISTS OF STYLIZED FLOWERS AND DIAMONDS IN AN OVERALL DIAMOND SHAPE.

FOR BACKPACKS, BOOK BAGS, SPORTS BAGS, BUM BAGS, WALLETS AND HANDBAGS; EVENING HANDBAGS; FASHION HANDBAGS; GENTLEMEN'S HANDBAGS; HANDBAG FRAMES; HANDBAGS; HANDBAGS FOR LADIES; HANDBAGS FOR MEN; HANDBAGS, PURSES AND WALLETS; LEATHER HANDBAGS; STRAPS FOR HANDBAGS (U.S. CLS. 1, 2, 3, 22 AND 41).

NICHOLAS COLEMAN, EXAMINING ATTORNEY

SN 85-273,924. FARID MESKIN, LOS ANGELES, CA. FILED 3-22-2011.



OWNER OF U.S. REG. NO. 1,941,196.

THE COLOR(S) RED, BLACK, WHITE, PINKISH TAN AND BLUE IS/ARE CLAIMED AS A FEATURE OF THE MARK.

THE MARK CONSISTS OF THE TERM "LAVIVE" IN RED IN STYLIZED FORM WITH THE DESIGN OF OPEN RED LIPS AND AN OPEN MOUTH IN BLACK WITH THREE TEETH IN WHITE AND A LOWER PORTION OF A FACE IN PROFILE IN PINKISH TAN ON A BLUE BACKGROUND.

FOR HANDBAGS, TOTE BAGS, COSMETIC BAGS SOLD EMPTY, WALLETS, ATTACHE CASES, BACKPACKS, LUGGAGE AND LEATHER KEY CHAINS (U.S. CLS. 1, 2, 3, 22 AND 41).

JOHN E. MICHOS, EXAMINING ATTORNEY

CLASS 18—(Continued).

SN 85-276,932. SYMONS, DOMINIC, PASADENA, CA. FILED 3-25-2011.

BLUELOUNGE

THE MARK CONSISTS OF STANDARD CHARACTERS WITHOUT CLAIM TO ANY PARTICULAR FONT, STYLE, SIZE, OR COLOR.

FOR ALL PURPOSE SPORT BAGS; ALL-PURPOSE ATHLETIC BAGS; ALL-PURPOSE CARRYING BAGS; ALL-PURPOSE REUSABLE CARRYING BAGS; AMENITY BAGS SOLD EMPTY; ANIMAL GAME BAGS; ATHLETIC BAGS; BABY CARRYING BAGS; BACKPACKS, BOOK BAGS, SPORTS BAGS, BUM BAGS, WALLETS AND HANDBAGS; BAGS FOR PACKAGING OF LEATHER; BAGS AND HOLDALLS FOR SPORTS CLOTHING; BAGS FOR CARRYING BABIES' ACCESSORIES; BAGS FOR CLIMBERS IN THE NATURE OF ALL-PURPOSE CARRYING BAGS; BAGS FOR SPORTS; BAGS FOR UMBRELLAS; BARREL BAGS; BEACH BAGS; BELT BAGS; BELT BAGS AND HIP BAGS; BOOK BAGS; BOSTON BAGS; BUM BAGS; CANTLE BAGS; CANVAS SHOPPING BAGS; CARRY-ALL BAGS; CARRY-ON BAGS; CHALK BAGS; CHARM BAGS (OMAMORI-IRE); CLUTCH BAGS; COSMETIC BAGS SOLD EMPTY; DIAPER BAGS; DOLLY BAGS; DRAWSTRING BAGS; DRY BAGS; DUFFEL BAGS; DUFFEL BAGS FOR TRAVEL; DUFFLE BAGS; FEED BAGS FOR ANIMALS; FLEXIBLE BAGS FOR GARMENTS; FLIGHT BAGS; GARMENT BAGS FOR TRAVEL; GARMENT BAGS FOR TRAVEL MADE OF LEATHER; GENERAL PURPOSE BAGS FOR CARRYING YOGA EQUIPMENT; GENERAL PURPOSE BAGS FOR HOLDING DANCE EQUIPMENT; GENERAL PURPOSE SPORT TROLLEY BAGS; GLADSTONE BAGS; GYM BAGS; HARD-SIDED AND SOFT-SIDED CARRY-ON BAGS AND GYM BAGS; HIKING BAGS; HOBO BAGS; HORSE TAIL BAGS; HUNTERS' GAME BAGS; HUNTING BAGS; KEY BAGS; KIT BAGS; KNITTED BAGS, NOT OF PRECIOUS METALS; LEATHER AND IMITATION LEATHER BAGS; LEATHER AND IMITATION LEATHER SPORT BAGS AND GENERAL PURPOSE TROLLEY BAGS; LEATHER BAGS AND WALLETS; LEATHER BAGS FOR MERCHANDISE PACKAGING; LEATHER BAGS, SUITCASES AND WALLETS; LEATHER SHOPPING BAGS; MAKE-UP BAGS SOLD EMPTY; MEN'S CLUTCH BAGS; MESH SHOPPING BAGS; MESSENGER BAGS; MILITARY DUFFLE BAGS, GARMENT BAGS FOR TRAVEL, TOTE BAGS, SHOULDER BAGS AND BACKPACKS; OVERNIGHT BAGS; PET ACCESSORIES, NAMELY, CANVAS, VINYL AND LEATHER POUCHES FOR HOLDING DISPOSABLE BAGS TO PLACE PET WASTE IN; PET ACCESSORIES, NAMELY, SPECIALLY DESIGNED CANVAS, VINYL OR LEATHER BAGS ATTACHED TO ANIMAL LEASHES FOR HOLDING SMALL ITEMS SUCH AS KEYS, CREDIT CARDS, MONEY OR DISPOSABLE BAGS FOR DISPOSING OF PET WASTE; POMMEL BAGS; POUCHES AND BAGS SOLD EMPTY FOR ATTACHMENT TO BACKPACKS; REUSABLE SHOPPING BAGS; REUSABLE TEXTILE PRODUCE BAGS TO CARRY PRODUCE FROM GROCERY STORES AND FARMER'S MARKETS; ROLL BAGS; SACK PACKS, NAMELY, DRAWSTRING BAGS USED AS BACKPACKS; SADDLE HORN BAGS; SADDLERY, NAMELY, HORN BAGS; SCHOOL BAGS; SCHOOL BOOK BAGS; SHAVING BAGS SOLD EMPTY; SHOE BAGS FOR TRAVEL; SHOPPING BAGS MADE OF SKIN; SHOPPING BAGS WITH WHEELS ATTACHED; SHOULDER BAGS; SLING BAGS; SLING BAGS FOR CARRYING INFANTS; SMALL BAGS

CLASS 18—(Continued).

FOR MEN; SOUVENIR BAGS; SPORT BAGS; SPORTS BAGS; SPORTSMAN'S HUNTING BAGS; STRING BAGS FOR SHOPPING; SUIT BAGS; TEXTILE SHOPPING BAGS; TOILETRY BAGS SOLD EMPTY; TOOL BAGS SOLD EMPTY; TOTE BAGS; TRAVEL BAGS; TRAVELLING BAGS; TRAVELLING BAGS; WAIST BAGS; WASH BAGS FOR CARRYING TOILETRIES; WHEELED BAGS; WHEELED DUFFLE BAGS; WHEELED MESSENGER BAGS; WHEELED SHOPPING BAGS; WHEELED TOTE BAGS; WINE BAGS WITH HANDLES FOR CARRYING OR HOLDING WINE; WRIST MOUNTED CARRYALL BAGS; WRISTLET BAGS (U.S. CLS. 1, 2, 3, 22 AND 41).
ANDREW RHIM, EXAMINING ATTORNEY

SN 85-278,952. GENESIS HANDBAGS, INC, SOUTH EL MONTE, CA. FILED 3-28-2011.



THE MARK CONSISTS OF A DESIGN OF TWO HEARTS OVERLAPPING WITH ARTISTIC DESIGNS INSIDE.

FOR COSMETIC BAGS SOLD EMPTY; HANDBAGS; MESSENGER BAGS; WALLETS (U.S. CLS. 1, 2, 3, 22 AND 41).

APRIL HESIK, EXAMINING ATTORNEY

SN 85-279,496. MCCLOSKEY, JULIE MITCHELL, SAN PEDRO, CA. FILED 3-29-2011.

EPONA

THE MARK CONSISTS OF STANDARD CHARACTERS WITHOUT CLAIM TO ANY PARTICULAR FONT, STYLE, SIZE, OR COLOR.

FOR BACKPACKS, BOOK BAGS, SPORTS BAGS, BUM BAGS, WALLETS AND HANDBAGS; CHANGE PURSES; CLUTCH PURSES; CLUTCHES; COIN PURSES; COIN PURSES NOT MADE OF PRECIOUS METAL; DOLLY BAGS; EVENING HANDBAGS; FASHION HANDBAGS; GENTLEMEN'S HANDBAGS; HANDBAGS; HANDBAGS FOR LADIES; HANDBAGS FOR MEN; HANDBAGS, PURSES AND WALLETS; LEATHER HANDBAGS; LEATHER PURSES; MULTI-PURPOSE PURSES; PURSES; PURSES AND WALLETS; PURSES NOT MADE OF PRECIOUS METAL; SMALL CLUTCH PURSES; SMALL PURSES; STRAPS FOR HANDBAGS (U.S. CLS. 1, 2, 3, 22 AND 41).

JENNIFER MARTIN, EXAMINING ATTORNEY

CLASS 18—(Continued).

SN 85-283,228. PURA BOTANICA, LLC, LIGHTHOUSE POINT, FL. FILED 3-31-2011.

Passport To Bliss

THE MARK CONSISTS OF STANDARD CHARACTERS WITHOUT CLAIM TO ANY PARTICULAR FONT, STYLE, SIZE, OR COLOR.

FOR TRAVEL BAGS (U.S. CLS. 1, 2, 3, 22 AND 41).
FIRST USE 9-1-2010; IN COMMERCE 9-1-2010.
JEFFREY LOOK, EXAMINING ATTORNEY

CLASS 18—(Continued).

SN 85-291,057. DOKUR CENGIZ, HANDE, LA GRANGE, IL. FILED 4-9-2011.

SILLY BUDDY 

THE MARK CONSISTS OF THE STYLIZED TEXT "SILLY BUDDY" ON TO THE LEFT, AND A BALL ON THE RIGHT. FOR DOG AND CAT COLLARS ; HARNESES FOR DOGS ; DOG BOW TIES ; DOG LEASHES (U.S. CLS. 1, 2, 3, 22 AND 41).

FIRST USE 5-1-2010; IN COMMERCE 6-1-2010.
JOHN HWANG, EXAMINING ATTORNEY

SN 85-289,001. LIVE NATION WORLDWIDE, INC., BEVERLY HILLS, CA. FILED 4-7-2011.

ELECTRONIC NATION

THE MARK CONSISTS OF STANDARD CHARACTERS WITHOUT CLAIM TO ANY PARTICULAR FONT, STYLE, SIZE, OR COLOR.

FOR BAGS, NAMELY, TOTE BAGS, ALL-PURPOSE CARRYING BAGS, BACKPACKS, DUFFEL BAGS (U.S. CLS. 1, 2, 3, 22 AND 41).
DAVID HOFFMAN, EXAMINING ATTORNEY

SN 85-291,069. ZEIDMAN, ROBERT M, DBA SAMANNA DESIGNS, CUPERTINO, CA. FILED 4-9-2011.

SamAnna

THE MARK CONSISTS OF STANDARD CHARACTERS WITHOUT CLAIM TO ANY PARTICULAR FONT, STYLE, SIZE, OR COLOR.

FOR WALLETS (U.S. CLS. 1, 2, 3, 22 AND 41).
FIRST USE 12-22-2010; IN COMMERCE 2-8-2011.
GEORGE LORENZO, EXAMINING ATTORNEY

SN 85-290,752. GROTEN, VICKIE, HONOLULU, HI. FILED 4-8-2011.

aller-pak

THE MARK CONSISTS OF STANDARD CHARACTERS WITHOUT CLAIM TO ANY PARTICULAR FONT, STYLE, SIZE, OR COLOR.

FOR POUCHES DESIGNED TO HOUSE ALLERGY MEDICINES WITH CLEAR OUTER COMPARTMENT FOR VISIBLE PERTINENT MEDICAL/CONTACT INFORMATION (U.S. CLS. 1, 2, 3, 22 AND 41).
JENNY PARK, EXAMINING ATTORNEY

SN 85-291,415. PRORODEO FILMS, INC., NEW YORK, NY. FILED 4-11-2011.

COWGIRLS OF FAITH

THE MARK CONSISTS OF STANDARD CHARACTERS WITHOUT CLAIM TO ANY PARTICULAR FONT, STYLE, SIZE, OR COLOR.

OWNER OF U.S. REG. NOS. 3,337,150, 3,932,847 AND OTHERS.

NO CLAIM IS MADE TO THE EXCLUSIVE RIGHT TO USE "COWGIRLS", APART FROM THE MARK AS SHOWN.

FOR HANDBAGS, EVENING BAGS, PURSES, WALLETS, POCKET WALLETS, COIN PURSES, TOTE BAGS, TRAVEL BAGS, ALL PURPOSE CARRYING BAGS, SHOULDER BAGS, ATHLETIC BAGS, BEACH BAGS, SCHOOL BAGS, BACKPACKS, OVERNIGHT BAGS, COSMETIC BAGS SOLD EMPTY, HANDBAG STRAPS; KEY HOLDERS, NAMELY, POUCHES FOR HOLDING KEYS; LUGGAGE (U.S. CLS. 1, 2, 3, 22 AND 41).
FRANK LATTUCA, EXAMINING ATTORNEY

CLASS 18—(Continued).

SN 85-292,318. GENESIS HANDBAGS, INC., SOUTH EL MONTE, CA. FILED 4-11-2011.

Doble Corazon

THE MARK CONSISTS OF STANDARD CHARACTERS WITHOUT CLAIM TO ANY PARTICULAR FONT, STYLE, SIZE, OR COLOR.

THE ENGLISH TRANSLATION OF "DOBLE CORAZON" IN THE MARK IS "TWO HEARTS".

FOR COSMETIC BAGS SOLD EMPTY; HANDBAGS; MESSENGER BAGS; WALLET(S) (U.S. CLS. 1, 2, 3, 22 AND 41).

MARK SPARACINO, EXAMINING ATTORNEY



SN 85-292,887. GABLE, ALEXANDRIA, WEST COVINA, CA. FILED 4-12-2011.

DOGMOPOLITAN

THE MARK CONSISTS OF STANDARD CHARACTERS WITHOUT CLAIM TO ANY PARTICULAR FONT, STYLE, SIZE, OR COLOR.

FOR ANIMAL HARNESSSES; ANIMAL LEASHES; COLLARS FOR PETS; PET CLOTHING (U.S. CLS. 1, 2, 3, 22 AND 41).

FIRST USE 6-8-1998; IN COMMERCE 6-8-1998. JAY BESCH, EXAMINING ATTORNEY



SN 85-295,653. NEXTTEN STAUER, LLC, BURNSVILLE, MN. FILED 4-14-2011.

DE DUILLIER

THE MARK CONSISTS OF STANDARD CHARACTERS WITHOUT CLAIM TO ANY PARTICULAR FONT, STYLE, SIZE, OR COLOR.

FOR HANDBAGS (U.S. CLS. 1, 2, 3, 22 AND 41). PATRICIA EVANKO, EXAMINING ATTORNEY

CLASS 18—(Continued).

SN 85-318,402. TONY MARGERIE & ASSOCIATES, SAUSALITO, CA. FILED 5-11-2011.

SUPERBLAST

THE MARK CONSISTS OF STANDARD CHARACTERS WITHOUT CLAIM TO ANY PARTICULAR FONT, STYLE, SIZE, OR COLOR.

OWNER OF U.S. REG. NOS. 1,613,960, 2,579,122 AND OTHERS.

FOR BACKPACKS; HANDBAGS; SPORTS BAGS; TOTE BAGS (U.S. CLS. 1, 2, 3, 22 AND 41).

REGINA DRUMMOND, EXAMINING ATTORNEY



SN 85-319,530. TONY MARGERIE & ASSOCIATES, SAUSALITO, CA. FILED 5-12-2011.



OWNER OF U.S. REG. NOS. 1,613,960, 1,887,253 AND 2,579,122.

THE MARK CONSISTS OF ROUND OWL WITH LARGE CIRCULAR EYES WITH A PUPIL IN THE MIDDLE, HAIR TUFTS ON EACH SIDE OF THE OWL, A TRIANGULAR NOSE, 3 LINES FOR EACH FOOT AND THE WORD SUPERBLAST CIRCLING THE DEPICTION OF THE OWL.

FOR BACKPACKS; HANDBAGS; SPORTS BAGS; TOTE BAGS (U.S. CLS. 1, 2, 3, 22 AND 41).

REGINA DRUMMOND, EXAMINING ATTORNEY

CLASS 18—(Continued).

SN 85-320,119. TONY MARGERIE & ASSOCIATES, SAUSALITO, CA. FILED 5-13-2011.



OWNER OF U.S. REG. NOS. 1,613,960, 1,887,253 AND 2,579,122.

THE MARK CONSISTS OF BLACK CHEETAH ON TOP OF THE WORD SUPERBLAST.

FOR BACKPACKS; HANDBAGS; SPORTS BAGS; TOTE BAGS (U.S. CLS. 1, 2, 3, 22 AND 41).
REGINA DRUMMOND, EXAMINING ATTORNEY

SN 85-326,211. LIVE NATION WORLDWIDE, INC., BEVERLY HILLS, CA. FILED 5-20-2011.

VENUE NATION

THE MARK CONSISTS OF STANDARD CHARACTERS WITHOUT CLAIM TO ANY PARTICULAR FONT, STYLE, SIZE, OR COLOR.

FOR BAGS, NAMELY, TOTE BAGS, ALL-PURPOSE CARRYING BAGS, BACKPACKS, DUFFEL BAGS, LEATHER KEY CHAINS (U.S. CLS. 1, 2, 3, 22 AND 41).
DAVID HOFFMAN, EXAMINING ATTORNEY

SN 85-344,618. BARILLA G. E R. FRATELLI - SOCIETÀ PER AZIONI, PARMA, ITALY, FILED 6-13-2011.

SPAGHETTATA

THE MARK CONSISTS OF STANDARD CHARACTERS WITHOUT CLAIM TO ANY PARTICULAR FONT, STYLE, SIZE, OR COLOR.

FOR TOTE BAGS; ALL PURPOSE CARRYING BAGS (U.S. CLS. 1, 2, 3, 22 AND 41).
AISHA CLARKE, EXAMINING ATTORNEY

CLASS 19—NON-METALLIC BUILDING MATERIALS

SN 79-089,242. METSÄLIITTO OSUUSKUNTA, FINLAND, FILED 10-19-2010.

THE MARK CONSISTS OF STANDARD CHARACTERS WITHOUT CLAIM TO ANY PARTICULAR FONT, STYLE, SIZE, OR COLOR.

OWNER OF INTERNATIONAL REGISTRATION 1056392 DATED 10-19-2010, EXPIRES 10-19-2020.

THE WORDING "KERTO" HAS NO MEANING IN A FOREIGN LANGUAGE.

FOR LAMINATED VENEER LUMBER (U.S. CLS. 1, 12, 33 AND 50).

WARREN L. OLANDRIA, EXAMINING ATTORNEY

SN 85-098,954. QUINN HOLTBY, EDMONTON, ALBERTA, CANADA, FILED 8-3-2010.

EXTENDED MINI KELLY KAN

THE MARK CONSISTS OF STANDARD CHARACTERS WITHOUT CLAIM TO ANY PARTICULAR FONT, STYLE, SIZE, OR COLOR.

PRIORITY CLAIMED UNDER SEC. 44(D) ON CANADA APPLICATION NO. 1468584, FILED 2-5-2010, REG. NO. TMA794310, DATED 3-31-2011, EXPIRES 3-31-2026.

NO CLAIM IS MADE TO THE EXCLUSIVE RIGHT TO USE "EXTENDED MINI KELLY", APART FROM THE MARK AS SHOWN.

FOR FLUID CONTAINMENT AND REDIRECTION APPARATUSES, NAMELY, NON-METAL PIPE JOINT ENCLOSURES FOR USE ON PIPE USED IN THE DRILLING AND SERVICING OF WELLS (U.S. CLS. 1, 12, 33 AND 50).

DAVID TOOLEY, EXAMINING ATTORNEY

SN 85-098,964. QUINN HOLTBY, EDMONTON, ALBERTA, CANADA, FILED 8-3-2010.

MINI ME KELLY KAN

THE MARK CONSISTS OF STANDARD CHARACTERS WITHOUT CLAIM TO ANY PARTICULAR FONT, STYLE, SIZE, OR COLOR.

OWNER OF CANADA REG. NO. TMA794055, DATED 3-28-2011, EXPIRES 3-28-2026.

NO CLAIM IS MADE TO THE EXCLUSIVE RIGHT TO USE "KELLY", APART FROM THE MARK AS SHOWN.

FOR FLUID CONTAINMENT AND REDIRECTION APPARATUSES, NAMELY, NON-METAL PIPE JOINT ENCLOSURES FOR USE ON PIPE USED IN THE DRILLING AND SERVICING OF WELLS (U.S. CLS. 1, 12, 33 AND 50).

DAVID TOOLEY, EXAMINING ATTORNEY

CLASS 19—(Continued).

SN 85-098,968. QUINN HOLTBY, EDMONTON, ALBERTA, CANADA, FILED 8-3-2010.

WELL SERVICING KELLY KAN

THE MARK CONSISTS OF STANDARD CHARACTERS WITHOUT CLAIM TO ANY PARTICULAR FONT, STYLE, SIZE, OR COLOR.

PRIORITY CLAIMED UNDER SEC. 44(D) ON CANADA APPLICATION NO. 1468580, FILED 2-5-2010, REG. NO. TMA794054, DATED 3-28-2011, EXPIRES 3-28-2026.

NO CLAIM IS MADE TO THE EXCLUSIVE RIGHT TO USE "WELL SERVICING KELLY", APART FROM THE MARK AS SHOWN.

FOR FLUID CONTAINMENT AND REDIRECTION APPARATUSES, NAMELY, NON-METAL PIPE JOINT ENCLOSURES FOR USE ON PIPE USED IN THE DRILLING AND SERVICING OF WELLS (U.S. CLS. 1, 12, 33 AND 50).

DAVID TOOLEY, EXAMINING ATTORNEY

SN 85-098,975. QUINN HOLTBY, EDMONTON, ALBERTA, CANADA, FILED 8-3-2010.

MINI KELLY KAN

THE MARK CONSISTS OF STANDARD CHARACTERS WITHOUT CLAIM TO ANY PARTICULAR FONT, STYLE, SIZE, OR COLOR.

PRIORITY CLAIMED UNDER SEC. 44(D) ON CANADA APPLICATION NO. 1468581, FILED 2-5-2010, REG. NO. TMA794309, DATED 3-31-2011, EXPIRES 3-31-2026.

NO CLAIM IS MADE TO THE EXCLUSIVE RIGHT TO USE "MINI KELLY", APART FROM THE MARK AS SHOWN.

FOR FLUID CONTAINMENT AND REDIRECTION APPARATUSES, NAMELY, NON-METAL PIPE JOINT ENCLOSURES FOR USE ON PIPE USED IN THE DRILLING AND SERVICING OF WELLS (U.S. CLS. 1, 12, 33 AND 50).

DAVID TOOLEY, EXAMINING ATTORNEY

SN 85-100,307. WESTROC, INC, PLEASANT GROVE, UT. FILED 8-4-2010.

ENVIROCRETE

THE MARK CONSISTS OF STANDARD CHARACTERS WITHOUT CLAIM TO ANY PARTICULAR FONT, STYLE, SIZE, OR COLOR.

FOR CONCRETE, CEMENT MIXES AND ASPHALT (U.S. CLS. 1, 12, 33 AND 50).

ROBERT C. CLARK JR., EXAMINING ATTORNEY

CLASS 19—(Continued).

SN 85-128,250. HH TECHNOLOGIES, INC., BREMEN, AL. FILED 9-13-2010.



NO CLAIM IS MADE TO THE EXCLUSIVE RIGHT TO USE "DOCK SHADE", APART FROM THE MARK AS SHOWN.

THE MARK CONSISTS OF "DOCK SHADE" IN STYLIZED LETTERS UNDERNEATH AN IMAGE OF AN OPEN STYLIZED CIRCLE ENCOMPASSING A STYLIZED IMAGE OF A BOAT HULL AND WAVES OF WATER.

FOR NONMETAL PROTECTION SCREENS FOR ATTACHMENT TO OUTDOOR STRUCTURES FOR PROTECTING OBJECTS LOCATED THEREIN AGAINST STRONG WINDS AND DIRECT SUNLIGHT AND RAIN, NAMELY, FOR ATTACHMENT TO DOCKS TO PROTECT BOATS AND OTHER WATERCRAFT OR FURNITURE LOCATED THEREIN (U.S. CLS. 1, 12, 33 AND 50).

FIRST USE 3-15-2010; IN COMMERCE 3-15-2010.

TARA PATE, EXAMINING ATTORNEY

SN 85-134,583. THE WALL DOCTORX, LLC, UWCHLAND, PA. FILED 9-21-2010.



THE COLOR(S) YELLOW AND BLACK IS/ARE CLAIMED AS A FEATURE OF THE MARK.

THE MARK CONSISTS OF A RECTANGULAR BOX MADE UP OF ALTERNATING BLACK AND YELLOW DIAGONAL BARS SERVING AS AN OUTSIDE BORDER FOR ANOTHER RECTANGLE.

FOR REPAIR KITS CONTAINING VARIOUS COMBINATIONS OF, NAMELY, WALL-PLASTER COMPOUND, PATCHES MADE OF PLASTIC, PATCHES MADE OF DRYWALL, SANDPAPER, AND APPLICATORS MADE OF PLASTIC AND CARDBOARD, FOR REPAIRING WALLS, CEILINGS AND OTHER BUILDING SURFACES (U.S. CLS. 1, 12, 33 AND 50).

DARRYL SPRULL, EXAMINING ATTORNEY

CLASS 19—(Continued).

SN 85-137,201. CAYLOR SPORTS SANDS LP, HEWITT, TX. FILED 9-24-2010.

CAYLOR GREEN'S PLUS

THE MARK CONSISTS OF STANDARD CHARACTERS WITHOUT CLAIM TO ANY PARTICULAR FONT, STYLE, SIZE, OR COLOR.

NO CLAIM IS MADE TO THE EXCLUSIVE RIGHT TO USE "GREEN'S", APART FROM THE MARK AS SHOWN.

FOR SILICA SAND USED FOR TOP DRESSING SPORTS FIELDS SUCH AS VOLLEY BALL COURTS AND GOLF COURSES (U.S. CLS. 1, 12, 33 AND 50).

DANIEL CAPSHAW, EXAMINING ATTORNEY

CLASS 19—(Continued).

SN 85-152,212. ZHEJIANG DADONGWU GREENHOME WOOD CO., LTD., HUZHOU CITY, CHINA, FILED 10-13-2010.



NO CLAIM IS MADE TO THE EXCLUSIVE RIGHT TO USE "GREENHOME", APART FROM THE MARK AS SHOWN.

THE MARK CONSISTS OF A STYLIZED LETTER "G" WITH FOUR CHINESE CHARACTERS AND THE TERM "GREENHOME" IMMEDIATELY TO THE RIGHT OF THE LETTER "G".

THE ENGLISH TRANSLATION OF THE NON-LATIN CHARACTERS TRANSLITERATE TO "LU JIA DI BAN" IN THE MARK IS "LU" MEANS "OF CALLIGRAPHY" AND IS ALSO "A SURNAME"; "JIA" MEANS "A FAMILY, A HOUSEHOLD OR A HOME" AND AS A SUFFIX "IT DESIGNATES THE SPECIALTY OF A PERSON"; "DI" MEANS "THE EARTH; LAND; SOIL; THE GROUND; THE FIELDS; A PLACE; A STAND; A POSITION OR THE BACKGROUND"; AND "BAN" MEANS "A BOARD; A PLANK OR A SLAB".

THE NON-LATIN CHARACTERS IN THE MARK TRANSLITERATE TO "LU JIA DI BAN" AND THIS HAS NO MEANING IN A FOREIGN LANGUAGE.

FOR FLOOR BOARDS (U.S. CLS. 1, 12, 33 AND 50).
GIANCARLO CASTRO, EXAMINING ATTORNEY

SN 85-144,855. LG HAUSYS, LTD, SEOUL, REPUBLIC OF KOREA, FILED 10-4-2010.

HI-SASH

THE MARK CONSISTS OF STANDARD CHARACTERS WITHOUT CLAIM TO ANY PARTICULAR FONT, STYLE, SIZE, OR COLOR.

OWNER OF REPUBLIC OF KOREA REG. NO. 267794, DATED 6-30-1993, EXPIRES 6-30-2013.

FOR NON-METALLIC WINDOWS; NON-METALLIC WINDOW FRAMES; NON-METALLIC ROTARY WINDOW FASTENERS (U.S. CLS. 1, 12, 33 AND 50).

LINDA E. BLOHM, EXAMINING ATTORNEY

SN 85-180,840. CALIFORNIA INDUSTRIAL FACILITIES RESOURCES, INC., MONROE, WA. FILED 11-19-2010.

CALIFORNIA MEDIUM SHELTER SYSTEM

THE MARK CONSISTS OF STANDARD CHARACTERS WITHOUT CLAIM TO ANY PARTICULAR FONT, STYLE, SIZE, OR COLOR.

NO CLAIM IS MADE TO THE EXCLUSIVE RIGHT TO USE "MEDIUM SHELTER SYSTEM", APART FROM THE MARK AS SHOWN.

FOR NON-METAL SHELTER STRUCTURE (U.S. CLS. 1, 12, 33 AND 50).

FIRST USE 0-0-1998; IN COMMERCE 0-0-1998.
ERNEST SHOSHO, EXAMINING ATTORNEY

CLASS 19—(Continued).

SN 85-191,094. MOSHE KONSTANTIN, LAKE FOREST, IL.
FILED 12-6-2010.

SolaGlaze

THE MARK CONSISTS OF STANDARD CHARACTERS WITHOUT CLAIM TO ANY PARTICULAR FONT, STYLE, SIZE, OR COLOR.

FOR BUILDING MATERIALS, NAMELY, SOLAR AND DAYLIGHTING ROOF AND WALL PANELS FOR CONTROLLING LIGHT, SHADE AND SOLAR TRANSMISSION (U.S. CLS. 1, 12, 33 AND 50).

NAPOLEON SHARMA, EXAMINING ATTORNEY

CLASS 19—(Continued).

SN 85-206,383. LT RESOURCES, INC., SPRING, TX. FILED 12-28-2010.

"GREEN" RAILWAY PRODUCTS
FOR THE LONG HAUL

THE MARK CONSISTS OF STANDARD CHARACTERS WITHOUT CLAIM TO ANY PARTICULAR FONT, STYLE, SIZE, OR COLOR.

NO CLAIM IS MADE TO THE EXCLUSIVE RIGHT TO USE "GREEN RAILWAY PRODUCTS", APART FROM THE MARK AS SHOWN.

FOR GRADE CROSSINGS AND OTHER RELATED RAILROAD PRODUCTS MANUFACTURED FROM RECYCLED AND RECYCLABLE PLASTICS, NAMELY, RAILROAD GRADE CROSSINGS FOR ROADWAYS, PEDESTRIANS, ATVS, AND TRANSIT APPLICATIONS; RE-RAILING BLOCKS MANUFACTURED FROM RECYCLED AND RECYCLABLE PLASTICS; COMPOSITE TIES, NAMELY, RAILROAD TIES MANUFACTURED FROM RECYCLED AND RECYCLABLE PLASTICS; COMPOSITE BRIDGE MATERIAL MANUFACTURED FROM RECYCLED AND RECYCLABLE PLASTICS, NAMELY, BRIDGE TIES, STRINGERS, GUARDRAILS, CAPS, BRACES, DECKING, AND PILING (U.S. CLS. 1, 12, 33 AND 50).

FIRST USE 4-2-2010; IN COMMERCE 4-2-2010.

SCOTT BIBB, EXAMINING ATTORNEY

SN 85-204,139. LINDSAY MCKENZIE, HARROGATE N.YORKSHIRE, UNITED KINGDOM, FILED 12-22-2010.

BIOCLAD

THE MARK CONSISTS OF STANDARD CHARACTERS WITHOUT CLAIM TO ANY PARTICULAR FONT, STYLE, SIZE, OR COLOR.

OWNER OF ERP N CMNTY TM OFC REG. NO. 009589607, DATED 5-20-2011, EXPIRES 5-20-2021.

FOR BUILDING MATERIALS, NAMELY, NON-METALLIC ANTI-MICROBIAL PANELS, TILES OR BOARDS; NON-METAL CEILING PANELS; NON-METAL CLADDING FOR CONSTRUCTION AND BUILDING; NON-METAL DOOR PANELS; NON-METAL FLOOR PANELS; NON-METAL STRUCTURES FOR CONSTRUCTION OF WALLS, DOORS, CEILINGS; SYNTHETIC FLOORING MATERIALS OR WALL-CLADDINGS (U.S. CLS. 1, 12, 33 AND 50).

SUZANNE BLANE, EXAMINING ATTORNEY

SN 85-213,199. USPLY TRADING COMPANY, MEDLEY, FL. FILED 1-7-2011.



THE COLOR(S) GREEN AND WHITE IS/ARE CLAIMED AS A FEATURE OF THE MARK.

THE MARK CONSISTS OF THE WORD "USPLY" IN WHITE WITHIN A GREEN SLANTED RECTANGLE. THE REMAINDER OF THE WHITE IN THE DRAWING REPRESENTS BACKGROUND AREAS ONLY AND IS NOT PART OF THE MARK.

FOR PLYWOOD (U.S. CLS. 1, 12, 33 AND 50).

FIRST USE 8-1-2010; IN COMMERCE 8-1-2010.

MAUREEN DALL, EXAMINING ATTORNEY

CLASS 19—(Continued).

SN 85-218,811. COOK PRODUCTS, GREENFIELD, OH. FILED 1-16-2011.

Handy Post

THE MARK CONSISTS OF STANDARD CHARACTERS WITHOUT CLAIM TO ANY PARTICULAR FONT, STYLE, SIZE, OR COLOR.

NO CLAIM IS MADE TO THE EXCLUSIVE RIGHT TO USE "POST", APART FROM THE MARK AS SHOWN.

FOR CEMENT POSTS; NON-METAL FENCE POSTS; NON-METAL POSTS; PLASTIC BOUNDARY MARKING POSTS; PLASTIC POSTS WITH REFLECTIVE UV COATED DISCS ATTACHED; WOOD POSTS (U.S. CLS. 1, 12, 33 AND 50).

APRIL ROACH, EXAMINING ATTORNEY

CLASS 19—(Continued).

SN 85-269,128. SINGH, GURJEET, SHAH ALAM, SELANGOR, MALAYSIA, FILED 3-17-2011.



NO CLAIM IS MADE TO THE EXCLUSIVE RIGHT TO USE "PARQUETRY", APART FROM THE MARK AS SHOWN.

THE COLOR(S) BROWN, WHITE, AND BLACK IS/ARE CLAIMED AS A FEATURE OF THE MARK.

THE MARK CONSISTS OF THE WORD, "WOODLINE", NEXT TO AND STAGGERED ABOVE THE WORD, "PARQUETRY", BOTH IN WHITE STYLISTIC LETTERS; ABOVE GROUPINGS OF BROWN VERTICAL PARALLEL LINES APPEARING THROUGH THE TOP OF "WOODLINE" AND THROUGH THE BOTTOM OF "PARQUETRY"; WITH MIRROR IMAGES OF STYLISTIC BROWN SEA SHELLS; ALL AGAINST A BLACK BACKGROUND.

FOR ENGINEERED HARDWOOD FLOORING; PARQUET WOOD FLOORING; WOODEN FLOORING (U.S. CLS. 1, 12, 33 AND 50).

JOHN DWYER, EXAMINING ATTORNEY

SN 85-270,864. PANEL REY S.A., MONTERREY, N.L., MEXICO, FILED 3-18-2011.

SN 85-251,123. GROWING SPACES, LLC, PAGOSA SPRINGS, CO. FILED 2-24-2011.

Growing Spaces

THE MARK CONSISTS OF STANDARD CHARACTERS WITHOUT CLAIM TO ANY PARTICULAR FONT, STYLE, SIZE, OR COLOR.

OWNER OF U.S. REG. NOS. 3,671,337 AND 3,687,918.

NO CLAIM IS MADE TO THE EXCLUSIVE RIGHT TO USE "GROWING", APART FROM THE MARK AS SHOWN. FOR NON-METAL GEODESIC DOME SHAPED GREENHOUSE (U.S. CLS. 1, 12, 33 AND 50).

FIRST USE 7-1-1989; IN COMMERCE 7-1-1989.

JULIE VEPPUMTHARA, EXAMINING ATTORNEY

The logo for Panel Rey Glass Rey features the words "PANEL REY" and "GLASS REY" in a bold, black, sans-serif font. The words are arranged in two lines, with "PANEL REY" above "GLASS REY".

OWNER OF U.S. REG. NOS. 1,495,117, 3,692,587 AND 3,692,588.

NO CLAIM IS MADE TO THE EXCLUSIVE RIGHT TO USE "PANEL" AND "GLASS", APART FROM THE MARK AS SHOWN.

THE MARK CONSISTS OF THE WORDS "PANEL REY GLASS REY" WHEREIN THE WORDS "PANEL REY" ARE WRITTEN IN BOXES ABOVE AND IN SMALLER LETTER THAN THE WORDS "GLASS REY".

THE ENGLISH TRANSLATION OF "PANEL REY GLASS REY" IN THE MARK IS "KING PANEL KING GLASS".

FOR CONSTRUCTION MATERIAL, NAMELY, FIBER-GLASS FACED PANELS (U.S. CLS. 1, 12, 33 AND 50).

NELSON SNYDER, EXAMINING ATTORNEY

CLASS 19—(Continued).

SN 85-270,947. INNERFACE ARCHITECTURAL SIGNAGE, INC., ATLANTA, GA. FILED 3-18-2011.

ClearView

THE MARK CONSISTS OF THE WORDS "CLEARVIEW" WRITTEN WITHOUT A SPACE BETWEEN THE WORDS AND WITH A CAPITAL "C" AND A CAPITAL "V"; ALL OTHER LETTERS ARE LOWER CASE.

FOR ARCHITECTURAL SIGNAGE CONSISTING OF NON-LUMINOUS PLASTIC AND LAMINATE SIGNS AND REPLACEMENT PARTS USING MECHANICAL WALL FASTENERS AND PLASTIC STAND-OFFS SOLD AS A UNIT (U.S. CLS. 1, 12, 33 AND 50).

FIRST USE 6-1-2010; IN COMMERCE 6-1-2010.
CIMMERIAN COLEMAN, EXAMINING ATTORNEY

SN 85-271,363. BURNS, KEITH, ARVADA, CO. FILED 3-18-2011.

Brute Force Sandbags

THE MARK CONSISTS OF STANDARD CHARACTERS WITHOUT CLAIM TO ANY PARTICULAR FONT, STYLE, SIZE, OR COLOR.

NO CLAIM IS MADE TO THE EXCLUSIVE RIGHT TO USE "SANDBAGS", APART FROM THE MARK AS SHOWN.

FOR SANDBAGS (U.S. CLS. 1, 12, 33 AND 50).
FIRST USE 3-1-2010; IN COMMERCE 3-1-2010.
RONALD AIKENS, EXAMINING ATTORNEY

CLASS 19—(Continued).

SN 85-278,049. BOXLEY MATERIALS COMPANY, FORMERLY BLUE RIDGE STONE CORPORATION, ROANOKE, VA. FILED 3-27-2011.

BOXLEY

THE MARK CONSISTS OF STANDARD CHARACTERS WITHOUT CLAIM TO ANY PARTICULAR FONT, STYLE, SIZE, OR COLOR.

SEC. 2(F).

FOR STONE, SAND, CONCRETE, CONCRETE BLOCK, GRAVEL, BRICK, LIMESTONE AND MASONRY PRODUCTS, NAMELY, CINDERBLOCK, RETAINING WALL BLOCK, STEPPING STONES, CONCRETE PARKING BUMPERS, CONCRETE AIR CONDITIONING PADS, MASONRY LINTELS, SAND ABSORBING MASONRY UNITS AND CONCRETE CONTROL JOINTS (U.S. CLS. 1, 12, 33 AND 50).

FIRST USE 3-1-1996; IN COMMERCE 3-1-1996.
KIM MONINGHOFF, EXAMINING ATTORNEY

SN 85-290,529. CREATIVE MINES, LLC, ENCINITAS, CA. FILED 4-8-2011.

WE REALLY DIG ROCK

THE MARK CONSISTS OF STANDARD CHARACTERS WITHOUT CLAIM TO ANY PARTICULAR FONT, STYLE, SIZE, OR COLOR.

FOR BUILDING STONE; MANTELS FOR FIREPLACES OF STONE; NATURAL STONE; POOL SURROUNDS MADE OF STONE; STONES; WALL STONE (U.S. CLS. 1, 12, 33 AND 50).

MICHAEL ENGEL, EXAMINING ATTORNEY

SN 85-293,944. BORAL STONE PRODUCTS LLC, ROSWELL, GA. FILED 4-13-2011.

WOLF CREEK

THE MARK CONSISTS OF STANDARD CHARACTERS WITHOUT CLAIM TO ANY PARTICULAR FONT, STYLE, SIZE, OR COLOR.

FOR MANUFACTURED STONE; MANUFACTURED STONE VENEER (U.S. CLS. 1, 12, 33 AND 50).

FIRST USE 11-0-2010; IN COMMERCE 11-0-2010.
LIEF MARTIN, EXAMINING ATTORNEY

CLASS 19—(Continued).

SN 85-294,233. ASPHALT MATERIALS, INC., INDIANAPOLIS, IN. FILED 4-13-2011.

C-CAP

THE MARK CONSISTS OF STANDARD CHARACTERS WITHOUT CLAIM TO ANY PARTICULAR FONT, STYLE, SIZE, OR COLOR.

FOR ASPHALT; ASPHALT PAVING COMPOSITIONS (U.S. CLS. 1, 12, 33 AND 50).
JAY BESCH, EXAMINING ATTORNEY

CLASS 19—(Continued).

SN 85-295,076. BORAL STONE PRODUCTS LLC, ROSWELL, GA. FILED 4-14-2011.

BLACK MOUNTAIN

THE MARK CONSISTS OF STANDARD CHARACTERS WITHOUT CLAIM TO ANY PARTICULAR FONT, STYLE, SIZE, OR COLOR.

FOR MANUFACTURED STONE; MANUFACTURED STONE VENEER (U.S. CLS. 1, 12, 33 AND 50).
FIRST USE 1-0-2011; IN COMMERCE 1-0-2011.
LIEF MARTIN, EXAMINING ATTORNEY

SN 85-294,276. FLEXDECK, LLC, MIAMI, FL. FILED 4-13-2011.

FlexDeck

THE MARK CONSISTS OF STANDARD CHARACTERS WITHOUT CLAIM TO ANY PARTICULAR FONT, STYLE, SIZE, OR COLOR.

FOR HARDWOOD DECKING FLOOR TILES; HARDWOOD DECKING AND FLOORING FOR OUTDOOR USE (U.S. CLS. 1, 12, 33 AND 50).
MARK SPARACINO, EXAMINING ATTORNEY

SN 85-301,018. THERMA-TRU CORP., MAUMEE, OH. FILED 4-21-2011.

ASHLEIGH

THE MARK CONSISTS OF STANDARD CHARACTERS WITHOUT CLAIM TO ANY PARTICULAR FONT, STYLE, SIZE, OR COLOR.

FOR DECORATIVE GLASS PANELS FOR DOORS (U.S. CLS. 1, 12, 33 AND 50).
ROBERT C. CLARK JR., EXAMINING ATTORNEY

SN 85-294,439. GUARDIAN INDUSTRIES CORP., AUBURN HILLS, MI. FILED 4-13-2011.

GUARDIAN AGRO

THE MARK CONSISTS OF STANDARD CHARACTERS WITHOUT CLAIM TO ANY PARTICULAR FONT, STYLE, SIZE, OR COLOR.

OWNER OF U.S. REG. NOS. 2,839,435, 3,943,489 AND OTHERS.
FOR BUILDING GLASS FOR USE IN THE ARCHITECTURAL FIELD; BUILDING GLASS FOR USE IN GREENHOUSES (U.S. CLS. 1, 12, 33 AND 50).
ERNEST SHOSHO, EXAMINING ATTORNEY

SN 85-308,342. AMCOL INTERNATIONAL CORPORATION, HOFFMAN ESTATES, IL. FILED 4-29-2011.

SWELLTITE

THE MARK CONSISTS OF STANDARD CHARACTERS WITHOUT CLAIM TO ANY PARTICULAR FONT, STYLE, SIZE, OR COLOR.

OWNER OF U.S. REG. NO. 1,503,029.
FOR WATERPROOFING MEMBRANES FOR ROOFING, FLOORS, WALLS, FOUNDATIONS, SLABS, DECKS AND TUNNELS (U.S. CLS. 1, 12, 33 AND 50).
FIRST USE 5-30-1986; IN COMMERCE 5-30-1986.
DOMINIC FATHY, EXAMINING ATTORNEY

CLASS 19—(Continued).

SN 85-310,139. COLUMBIA FOREST PRODUCTS, INC., GREENSBORO, NC. FILED 5-2-2011.

PLYprints

THE MARK CONSISTS OF STANDARD CHARACTERS WITHOUT CLAIM TO ANY PARTICULAR FONT, STYLE, SIZE, OR COLOR.

FOR DECORATIVE HARDWOOD PLYWOOD AND VENEER (U.S. CLS. 1, 12, 33 AND 50).

FIRST USE 11-0-2008; IN COMMERCE 11-0-2008.
MIDGE BUTLER, EXAMINING ATTORNEY

CLASS 19—(Continued).

SN 85-323,316. COLUMBIA FOREST PRODUCTS, INC., GREENSBORO, NC. FILED 5-17-2011.

CAN/AM GOLD+

THE MARK CONSISTS OF STANDARD CHARACTERS WITHOUT CLAIM TO ANY PARTICULAR FONT, STYLE, SIZE, OR COLOR.

FOR DECORATIVE HARDWOOD PLYWOOD AND WOOD VENEER (U.S. CLS. 1, 12, 33 AND 50).

FIRST USE 1-15-2009; IN COMMERCE 1-15-2009.
MIDGE BUTLER, EXAMINING ATTORNEY

SN 85-318,089. TAPHANDLES LLC, SEATTLE, WA. FILED 5-11-2011.

SELL MORE BEER

THE MARK CONSISTS OF STANDARD CHARACTERS WITHOUT CLAIM TO ANY PARTICULAR FONT, STYLE, SIZE, OR COLOR.

FOR NON-LUMINOUS, NON-MECHANICAL SIGNS NOT OF METAL (U.S. CLS. 1, 12, 33 AND 50).

DAWN FELDMAN, EXAMINING ATTORNEY

SN 85-328,594. CREATIVE MINES, LLC, ENCINITAS, CA. FILED 5-24-2011.

CHOICE CUTS

THE MARK CONSISTS OF STANDARD CHARACTERS WITHOUT CLAIM TO ANY PARTICULAR FONT, STYLE, SIZE, OR COLOR.

FOR BUILDING STONE; MANTELS FOR FIREPLACES OF STONE; NATURAL STONE; POOL SURROUNDS MADE OF STONE; STONES; WALL STONE (U.S. CLS. 1, 12, 33 AND 50).

MICHAEL ENGEL, EXAMINING ATTORNEY

SN 85-320,681. ROBERTS CONSOLIDATED INDUSTRIES, INC., BOCA RATON, FL. FILED 5-13-2011.

SOFT STRIDE

THE MARK CONSISTS OF STANDARD CHARACTERS WITHOUT CLAIM TO ANY PARTICULAR FONT, STYLE, SIZE, OR COLOR.

FOR UNDERLAYMENT FOR LAMINATE FLOORING (U.S. CLS. 1, 12, 33 AND 50).

FIRST USE 7-0-2010; IN COMMERCE 7-0-2010.
MATTHEW KLINE, EXAMINING ATTORNEY

SN 85-343,544. UNITED STATES GYPSUM COMPANY, CHICAGO, IL. FILED 6-10-2011.

LEVELROCK UltraArmor

THE MARK CONSISTS OF STANDARD CHARACTERS WITHOUT CLAIM TO ANY PARTICULAR FONT, STYLE, SIZE, OR COLOR.

OWNER OF U.S. REG. NO. 2,498,435.
FOR FLOORING UNDERLAYMENTS (U.S. CLS. 1, 12, 33 AND 50).

RONALD MCMORROW, EXAMINING ATTORNEY

CLASS 20—FURNITURE AND ARTICLES NOT OTHERWISE CLASSIFIED

SN 76-706,234. CHANNELL COMMERCIAL CORPORATION, TEMECULA, CA. FILED 2-1-2011.

BUSHMAN

THE MARK CONSISTS OF STANDARD CHARACTERS WITHOUT CLAIM TO ANY PARTICULAR FONT, STYLE, SIZE, OR COLOR.

OWNER OF U.S. REG. NOS. 3,268,901 AND 3,481,152. FOR POLYETHYLENE TANKS, NAMELY, RAIN-WATER STORAGE TANKS, MOLASSES TANKS, TRANSPORTER TANKS, BELLY TANKS; OTHER POLY-ETHYLENE PRODUCTS, NAMELY, GRADE LEVEL BOXES, VAULTS, AND HAND HOLES ALL IN THE NATURE OF PLASTIC STORAGE CONTAINERS FOR INDUSTRIAL OR COMMERCIAL USE (U.S. CLS. 2, 13, 22, 25, 32 AND 50).

TASNEEM HUSSAIN, EXAMINING ATTORNEY

SN 77-686,364. DIFFRIENT, NIELS, RIDGEFIELD, CT. FILED 3-9-2009.

DIFFRIENT WORLD

THE MARK CONSISTS OF STANDARD CHARACTERS WITHOUT CLAIM TO ANY PARTICULAR FONT, STYLE, SIZE, OR COLOR.

THE NAME(S), PORTRAIT(S), AND/OR SIGNATURE(S) SHOWN IN THE MARK IDENTIFIES NIELS DIFFRIENT, WHOSE CONSENT(S) TO REGISTER IS MADE OF RECORD.

FOR FURNITURE, NAMELY, SEATING, CHAIRS, AND STOOLS (U.S. CLS. 2, 13, 22, 25, 32 AND 50).

FIRST USE 12-20-2010; IN COMMERCE 12-20-2010. WILLIAM BRECKENFELD, EXAMINING ATTORNEY

SN 79-098,056. OI OI PTY LTD, MALVERN VIC 3144, AUSTRALIA, FILED 3-24-2011.

Oi Oi

THE MARK CONSISTS OF STANDARD CHARACTERS WITHOUT CLAIM TO ANY PARTICULAR FONT, STYLE, SIZE, OR COLOR.

OWNER OF INTERNATIONAL REGISTRATION 1079203 DATED 3-24-2011, EXPIRES 3-24-2021.

FOR NURSERY FURNITURE, INCLUDING HIGH-CHAIRS (U.S. CLS. 2, 13, 22, 25, 32 AND 50).

STEVEN R. FINE, EXAMINING ATTORNEY

CLASS 20—(Continued).

SN 85-047,659. HOME PLUS GROUP INC, DBA 405 CABINETS & STONE, GARDEN GROVE, CA. FILED 5-25-2010.



NO CLAIM IS MADE TO THE EXCLUSIVE RIGHT TO USE "CABINETS", APART FROM THE MARK AS SHOWN.

THE MARK CONSISTS OF AN ELLIPSE; AND INSIDE THE ELLIPSE, THERE ARE "ARTCRAFT", "CABINETS", AND A LINE. THEY ARE ARRANGED AS FOLLOWS: "ARTCRAFT" IS BIG AND AT THE CENTER OF THE ELLIPSE; BELOW "ARTCRAFT" IS THE LINE WHICH HAS A GAP UNDER THE LETTER "C" OF "ARTCRAFT" BECAUSE THE LETTER "C" THAT IS BIGGER OCCUPIES THE SPACE OF THIS LINE; BELOW THE LINE IS "CABINETS".

FOR KITCHEN CABINETS (U.S. CLS. 2, 13, 22, 25, 32 AND 50).

FIRST USE 8-22-2007; IN COMMERCE 2-22-2008. STEVEN JACKSON, EXAMINING ATTORNEY

SN 85-063,525. PLUNKETT HOME FURNISHINGS, GLENVIEW, IL. FILED 6-15-2010.



NO CLAIM IS MADE TO THE EXCLUSIVE RIGHT TO USE "HOME FURNISHINGS", APART FROM THE MARK AS SHOWN.

THE MARK CONSISTS OF THE STYLIZED WORDING "PLUNKETT HOME FURNISHINGS" WITH A SEAL DESIGN CONSISTING OF A HELMET WITH A CASTLE ABOVE IT AND A HORSE ON EITHER SIDE. THE HORSES APPEAR ABOVE A SHIELD CONTAINING A DIAGONAL BAND EXTENDING FROM THE TOP LEFT TO THE LOWER RIGHT CORNER WITH TWO CROSSED SWORDS APPEARING IN THE UPPER RIGHT CORNER OF THE SHIELD AND THREE CASTLE SHAPED ROOKS APPEARING IN THE BOTTOM LEFT CORNER OF THE SHIELD.

FOR FURNITURE (U.S. CLS. 2, 13, 22, 25, 32 AND 50). JOHN KELLY, EXAMINING ATTORNEY

CLASS 20—(Continued).

SN 85-099,704. MARTIN, JOHN C, BIRMINGHAM, MI. FILED 8-4-2010.

LAMPLOCK

THE MARK CONSISTS OF STANDARD CHARACTERS WITHOUT CLAIM TO ANY PARTICULAR FONT, STYLE, SIZE, OR COLOR.

FOR A PLASTIC DEVICE IN THE NATURE OF A NON-METAL CLAMP THAT ATTACHES TO FURNITURE TO RESTRAIN ELECTRICAL CORDS OF OBJECTS INDEPENDENT OF THE FURNITURE TO THAT FURNITURE (U.S. CLS. 2, 13, 22, 25, 32 AND 50).

JOHN DWYER, EXAMINING ATTORNEY

CLASS 20—(Continued).

SN 85-142,733. LOWE, KRESTEN, FT. MYERS, FL. FILED 10-1-2010.

THE DRESSING BUTLER

THE MARK CONSISTS OF STANDARD CHARACTERS WITHOUT CLAIM TO ANY PARTICULAR FONT, STYLE, SIZE, OR COLOR.

NO CLAIM IS MADE TO THE EXCLUSIVE RIGHT TO USE "DRESSING", APART FROM THE MARK AS SHOWN.

FOR A MANUALLY OPERATED DEVICE COMPRISED OF RODS, RACKS, SPRINGS, LEVERS, PULL-EYS AND CLAMPS FOR HOLDING, RAISING AND MANIPULATING GARMENTS TO AID IN DRESSING AND UNDRRESSING (U.S. CLS. 2, 13, 22, 25, 32 AND 50).

ANTHONY RINKER, EXAMINING ATTORNEY

SN 85-108,939. FUSION GOURMET, INC., GARDENA, CA. FILED 8-17-2010.

Louvre

THE MARK CONSISTS OF STANDARD CHARACTERS WITHOUT CLAIM TO ANY PARTICULAR FONT, STYLE, SIZE, OR COLOR.

FOR DECORATIVE BOXES MADE OF WOOD; PICTURE FRAMES; SHADOW BOXES (U.S. CLS. 2, 13, 22, 25, 32 AND 50).

FIRST USE 8-1-2007; IN COMMERCE 1-1-2009.
JIM RINGLE, EXAMINING ATTORNEY

SN 85-156,370. KINGSDOWN, INC., MEBANE, NC. FILED 10-19-2010.

CHILLY WAVE

THE MARK CONSISTS OF STANDARD CHARACTERS WITHOUT CLAIM TO ANY PARTICULAR FONT, STYLE, SIZE, OR COLOR.

NO CLAIM IS MADE TO THE EXCLUSIVE RIGHT TO USE "WAVE", APART FROM THE MARK AS SHOWN.

FOR FOAM INLAY SOLD AS AN INTEGRAL COMPONENT OF A MATTRESS (U.S. CLS. 2, 13, 22, 25, 32 AND 50).

KATHERINE CHANG, EXAMINING ATTORNEY

SN 85-130,038. KELLY OBRIOT, GROSSE POINTE PARK, MI. FILED 9-15-2010.

SECURE BEGINNINGS

THE MARK CONSISTS OF STANDARD CHARACTERS WITHOUT CLAIM TO ANY PARTICULAR FONT, STYLE, SIZE, OR COLOR.

FOR MATTRESSES, MATTRESS FOUNDATIONS (U.S. CLS. 2, 13, 22, 25, 32 AND 50).

DARRYL SPRUILL, EXAMINING ATTORNEY

SN 85-156,665. UNIVERSAL HOSPITAL SERVICES, INC., EDINA, MN. FILED 10-20-2010.

HARMONY

THE MARK CONSISTS OF STANDARD CHARACTERS WITHOUT CLAIM TO ANY PARTICULAR FONT, STYLE, SIZE, OR COLOR.

FOR MEDICAL APPARATUS, NAMELY, MEDICAL-SURGICAL HOSPITAL BED FRAMES (U.S. CLS. 2, 13, 22, 25, 32 AND 50).

VERNA BETH RIRIE, EXAMINING ATTORNEY

CLASS 20—(Continued).

SN 85-160,108. ARTSANA S.P.A., 22070 GRANDATE, COMO, ITALY, FILED 10-25-2010.



OWNER OF ERPN CMNTY TM OFC REG. NO. 008967821, DATED 8-10-2010, EXPIRES 3-19-2020.

THE COLOR(S) GRAY IS/ARE CLAIMED AS A FEATURE OF THE MARK.

THE MARK CONSISTS OF THE WORDING "I-SIT" IN STYLIZED FORM IN LIGHT AND DARK SHADES OF GRAY.

FOR HIGH CHAIRS FOR BABIES (U.S. CLS. 2, 13, 22, 25, 32 AND 50).

DAWN HAN, EXAMINING ATTORNEY

CLASS 20—(Continued).

SN 85-173,115. XIAMEN MILLION STONE ARTS & CRAFTS CO., LTD., XIAMEN, CHINA, FILED 11-10-2010.



NO CLAIM IS MADE TO THE EXCLUSIVE RIGHT TO USE "STONE ARTS", APART FROM THE MARK AS SHOWN.

THE MARK CONSISTS OF AN EAGLE'S HEAD WITH THE WORDING "MILLION STONE ARTS" BENEATH.

FOR FRAMES FOR PAINTINGS; FURNITURE; MIRRORS; ORNAMENTS OF HORN OR IVORY; PICTURE FRAMES WITH PLUSH DECORATIVE OUTER SURFACE; WORKS OF ART MADE OF WOOD; WORKS OF ART OF STONE WOOD, WAX, PLASTER, RESIN, LACQUER, FEATHERS AND PLASTIC (U.S. CLS. 2, 13, 22, 25, 32 AND 50).

FIRST USE 12-9-1999; IN COMMERCE 12-9-2002.

KIMBERLY PERRY, EXAMINING ATTORNEY

SN 85-210,623. MECHOSHADE SYSTEMS, INC., LONG ISLAND CITY, NY. FILED 1-5-2011.

EUROSHADE

THE MARK CONSISTS OF STANDARD CHARACTERS WITHOUT CLAIM TO ANY PARTICULAR FONT, STYLE, SIZE, OR COLOR.

FOR MOTORIZED AND MANUAL WINDOW SHADES (U.S. CLS. 2, 13, 22, 25, 32 AND 50).

FIRST USE 11-1-2010; IN COMMERCE 1-1-2011.

SARA BENJAMIN, EXAMINING ATTORNEY

SN 85-164,795. HOLLANDER HOME FASHIONS, LLC, BOCA RATON, FL. FILED 10-29-2010.

PERFECT REST

SN 85-219,868. HOLLANDER HOME FASHIONS, LLC, BOCA RATON, FL. FILED 1-18-2011.

CUDDLEBED

THE MARK CONSISTS OF STANDARD CHARACTERS WITHOUT CLAIM TO ANY PARTICULAR FONT, STYLE, SIZE, OR COLOR.

OWNER OF U.S. REG. NO. 2,900,607.

FOR PILLOWS, MATTRESS TOPPERS AND FEATHERBEDS (U.S. CLS. 2, 13, 22, 25, 32 AND 50).

CHERYL CLAYTON, EXAMINING ATTORNEY

THE MARK CONSISTS OF STANDARD CHARACTERS WITHOUT CLAIM TO ANY PARTICULAR FONT, STYLE, SIZE, OR COLOR.

OWNER OF U.S. REG. NO. 1,695,364.

FOR MATTRESS TOPPERS (U.S. CLS. 2, 13, 22, 25, 32 AND 50).

FIRST USE 7-9-2009; IN COMMERCE 7-9-2009.

JAMES GRIFFIN, EXAMINING ATTORNEY

CLASS 20—(Continued).

SN 85-224,198. CARROLL HOSPITAL GROUP INC., LONDON, ONTARIO, CANADA, FILED 1-24-2011.



PRIORITY CLAIMED UNDER SEC. 44(D) ON CANADA APPLICATION NO. 1,492,239, FILED 8-13-2010.

OWNER OF U.S. REG. NOS. 3,935,517 AND 3,935,518.

NO CLAIM IS MADE TO THE EXCLUSIVE RIGHT TO USE "HOSPITAL BEDS", APART FROM THE MARK AS SHOWN.

THE MARK CONSISTS OF THE LETTERS "CHG" WITH THE WORDS "HOSPITAL BEDS" DIRECTLY BELOW REVERSED OUT OF A SHADED RECTANGULAR BACKGROUND.

FOR HOSPITAL BEDS (U.S. CLS. 2, 13, 22, 25, 32 AND 50).

FIRST USE 7-16-2010; IN COMMERCE 7-16-2010.

BRENDAN REGAN, EXAMINING ATTORNEY

SN 85-244,856. KOLARITS, DANIEL, YORKVILLE, IL. FILED 2-17-2011.

GAY SPRAY

THE MARK CONSISTS OF STANDARD CHARACTERS WITHOUT CLAIM TO ANY PARTICULAR FONT, STYLE, SIZE, OR COLOR.

NO CLAIM IS MADE TO THE EXCLUSIVE RIGHT TO USE "SPRAY", APART FROM THE MARK AS SHOWN.

FOR NOVELTY GOODS IN THE NATURE OF A PLACEBO SPRAY USED TO ALTER ONE'S REACTION TO A SITUATION (U.S. CLS. 2, 13, 22, 25, 32 AND 50).

SUSAN STIGLITZ, EXAMINING ATTORNEY

SN 85-259,248. SANFORD, PETER B., MORRO BAY, CA. FILED 3-6-2011.



NO CLAIM IS MADE TO THE EXCLUSIVE RIGHT TO USE "THE ULTIMATE PAINTING SYSTEM", APART FROM THE MARK AS SHOWN.

THE MARK CONSISTS OF THE PHRASE "SNAPNSAVE" POSITIONED ABOVE THE WORDS "THE ULTIMATE PAINTING SYSTEM" WITH LIQUID APPEARING TO DRAIN FROM THE MIDDLE "N" IN "SNAPNSAVE" INTO THE "U" IN THE WORD "ULTIMATE".

FOR CAN LIDS MADE OUT OF PLASTIC AND SPECIALLY ADAPTED FOR TRANSFERRING THE CONTENTS OF A CAN TO ANOTHER CAN, POURING THE CONTENTS FROM A CAN, SEALING A CAN AND STACKING CANS (U.S. CLS. 2, 13, 22, 25, 32 AND 50).

JAMES LOVELACE, EXAMINING ATTORNEY

CLASS 20—(Continued).

SN 85-265,034. KIKKERLAND DESIGN, INC., NEW YORK, NY. FILED 3-11-2011.

RHINO

THE MARK CONSISTS OF STANDARD CHARACTERS WITHOUT CLAIM TO ANY PARTICULAR FONT, STYLE, SIZE, OR COLOR.

FOR PORTABLE STOOL, NAMELY, PLASTIC FOLDING STOOL (U.S. CLS. 2, 13, 22, 25, 32 AND 50).

FIRST USE 1-8-2011; IN COMMERCE 1-8-2011.

RENEE MCCRAY, EXAMINING ATTORNEY

SN 85-269,090. JOTLEY'S, LLC, CROWN POINT, IN. FILED 3-16-2011.



THE LINING IS FOR SHADING AND OUTLINING PURPOSES.

THE MARK CONSISTS OF A STYLIZED CAPITAL LETTER "E", FOLLOWED BY THE REVERSED IMAGE OF A STYLIZED LETTER "E" WHERE THE DISTAL EDGES OF THE TWO LETTERS FORM A BROKEN OVAL.

FOR NON-METAL CABLE CLIPS (U.S. CLS. 2, 13, 22, 25, 32 AND 50).

KATINA MISTER, EXAMINING ATTORNEY

CLASS 20—(Continued).

SN 85-271,027. SCHROEDER, CAROL H., DBA A-1 CAR STOP COMPANY, BRECKSVILLE, OH. FILED 3-18-2011.



NO CLAIM IS MADE TO THE EXCLUSIVE RIGHT TO USE "CAR", APART FROM THE MARK AS SHOWN.

THE MARK CONSISTS OF STANDARD TRAFFIC STOP SIGN, WITH THE WORD "CAR", WHICH IS ITALICIZED AT AN UPWARD ANGLE AND IS BUTTING UP AGAINST THE LEFT SIDE OF THE STOP SIGN. A VERTICAL LINE RUNS FROM THE TOP EDGE OF THE STOP SIGN TO THE TOP CENTER OF THE LETTER "O" IN THE WORD "STOP".

FOR VEHICLE PARKING ASSIST DEVICE FOR HELPING MOTORISTS PARK THEIR VEHICLE IN A DESIRED PLACE IN A GARAGE, NAMELY, A NYLON, POLYESTER AND POLYPROPYLENE LINE EXTENDING FROM THE CEILING AND SUPPORTING A BALL FOR THE PURPOSE OF DETERMINING THE DEPTH OF ENTRY INTO A PARKING AREA BY CONTACTING THE VEHICLE WINDSHIELD (U.S. CLS. 2, 13, 22, 25, 32 AND 50).

FIRST USE 2-17-2011; IN COMMERCE 2-17-2011.
GIANCARLO CASTRO, EXAMINING ATTORNEY

SN 85-274,059. SAWYER ETHAN JAMES, ENTERPRISE, AL. FILED 3-22-2011.

Yard Rides

THE MARK CONSISTS OF STANDARD CHARACTERS WITHOUT CLAIM TO ANY PARTICULAR FONT, STYLE, SIZE, OR COLOR.

FOR BENCHES MADE OF RECYCLED AUTOMOBILE HOODS (U.S. CLS. 2, 13, 22, 25, 32 AND 50).

TAMARA FRAZIER, EXAMINING ATTORNEY

SN 85-274,243. TRITON PRODUCTS, SOLON, OH. FILED 3-23-2011.

XtraWall

THE MARK CONSISTS OF STANDARD CHARACTERS WITHOUT CLAIM TO ANY PARTICULAR FONT, STYLE, SIZE, OR COLOR.

FOR WALL-MOUNTED TOOL RACKS (U.S. CLS. 2, 13, 22, 25, 32 AND 50).

FIRST USE 1-1-2011; IN COMMERCE 1-1-2011.
AMY HELLA, EXAMINING ATTORNEY

CLASS 20—(Continued).

SN 85-276,705. PRESENCE FROM INNOVATION, LLC, ST. LOUIS, MO. FILED 3-25-2011.

ECO-GLIDE

THE MARK CONSISTS OF STANDARD CHARACTERS WITHOUT CLAIM TO ANY PARTICULAR FONT, STYLE, SIZE, OR COLOR.

FOR PRODUCT MERCHANDISING DISPLAY UNITS AND INSERT FLOORS FOR USE THEREIN (U.S. CLS. 2, 13, 22, 25, 32 AND 50).

JOHN KELLY, EXAMINING ATTORNEY

SN 85-276,793. Q10 PRODUCTS LLC, TENAFLY, NJ. FILED 3-25-2011.

ENCHANTED HOME

THE MARK CONSISTS OF STANDARD CHARACTERS WITHOUT CLAIM TO ANY PARTICULAR FONT, STYLE, SIZE, OR COLOR.

NO CLAIM IS MADE TO THE EXCLUSIVE RIGHT TO USE "HOME", APART FROM THE MARK AS SHOWN.

FOR BOOK RESTS; BOOK STANDS; CHAIRS; CLOSET ACCESSORIES, NAMELY, BELT RACKS; CLOSET ACCESSORIES, NAMELY, CLOTHES BARS; CLOSET ACCESSORIES, NAMELY, SHOE RACKS; CLOTHES HANGERS; CLOTHES RODS; COAT RACKS; DECORATIVE BOXES MADE OF WOOD; DRESSERS; END TABLES; FOOT RESTS; FURNITURE; HAT RACKS; MAGAZINE RACKS; NON-METAL BINS; NON-METAL FABRIC HANGING ORGANIZER; NONMETAL AND NON-PAPER CONTAINERS FOR STORAGE OR TRANSPORT; OTTOMANS; PLASTIC BOXES; PREFABRICATED CLOSET ORGANIZATION SYSTEMS MADE OF WOOD; SHELVES FOR BOOKS; SHOE RACKS; STORAGE RACKS; TABLES; TIE RACKS; TOOL CHESTS NOT OF METAL; TOWEL RACKS; UPHOLSTERED FURNITURE; WINE RACKS; WRITING DESKS (U.S. CLS. 2, 13, 22, 25, 32 AND 50).

JOHN SCHUYLER YARD, EXAMINING ATTORNEY

SN 85-280,124. MICHAEL J. ELL, FREMONT, CA. FILED 3-29-2011.

CPAP NOOK

THE MARK CONSISTS OF STANDARD CHARACTERS WITHOUT CLAIM TO ANY PARTICULAR FONT, STYLE, SIZE, OR COLOR.

FOR CABINETS (U.S. CLS. 2, 13, 22, 25, 32 AND 50).
SUSAN RICHARDS, EXAMINING ATTORNEY

CLASS 20—(Continued).

SN 85-287,439. SIMPLISSE, INC., ST. LOUIS, MO. FILED 4-6-2011.

A WHOLE NEW ANGLE IN NURSING PILLOWS

THE MARK CONSISTS OF STANDARD CHARACTERS WITHOUT CLAIM TO ANY PARTICULAR FONT, STYLE, SIZE, OR COLOR.

NO CLAIM IS MADE TO THE EXCLUSIVE RIGHT TO USE "NURSING PILLOWS", APART FROM THE MARK AS SHOWN.

FOR MATERNITY PILLOWS (U.S. CLS. 2, 13, 22, 25, 32 AND 50).

FIRST USE 11-8-2010; IN COMMERCE 11-8-2010.
TEJBIR SINGH, EXAMINING ATTORNEY

SN 85-289,396. BEXCO ENTERPRISES, INC., MONTEBELLO, CA. FILED 4-7-2011.

FRANKLIN BEN

THE MARK CONSISTS OF THE WORDS "FRANKLIN" AND "BEN", SEPARATED BY A STYLIZED SEAL BEARING AN AMPERSAND.

FOR INDOOR HOUSEHOLD FURNITURE FOR BABIES AND CHILDREN; INDOOR HOUSEHOLD FURNITURE FOR BABIES AND CHILDREN, NAMELY DRESSERS, BUREAUS, ARMOIRES, ROCKING CHAIRS, CRIBS, TOY CHESTS, CHANGING TABLES, BEDS AND MATTRESSES, CONVERTIBLE BEDS, NAMELY, CRIBS WHICH CONVERT TO DAY BEDS OR FULL SIZE BEDS, AND TABLE AND CHAIR SETS (U.S. CLS. 2, 13, 22, 25, 32 AND 50).

BRENDAN REGAN, EXAMINING ATTORNEY

SN 85-289,651. BLUMENTHAL DISTRIBUTING, INC., DBA OFFICE STAR PRODUCTS, ONTARIO, CA. FILED 4-7-2011.

OSP HOSPITALITY

THE MARK CONSISTS OF STANDARD CHARACTERS WITHOUT CLAIM TO ANY PARTICULAR FONT, STYLE, SIZE, OR COLOR.

OWNER OF U.S. REG. NOS. 3,440,465 AND 3,517,819.
FOR OFFICE FURNITURE (U.S. CLS. 2, 13, 22, 25, 32 AND 50).

FIRST USE 10-0-2010; IN COMMERCE 10-0-2010.
GINA FINK, EXAMINING ATTORNEY

CLASS 20—(Continued).

SN 85-291,615. FOLLIS, MICHELE, MONTROSE, CO. FILED 4-11-2011.

hearts4globalgoodness.com

THE MARK CONSISTS OF STANDARD CHARACTERS WITHOUT CLAIM TO ANY PARTICULAR FONT, STYLE, SIZE, OR COLOR.

FOR WIND CHIMES (U.S. CLS. 2, 13, 22, 25, 32 AND 50).

FIRST USE 2-26-2011; IN COMMERCE 3-13-2011.
ANDREW LEASER, EXAMINING ATTORNEY

SN 85-291,637. PGS-PARAGON GLOBAL SOURCING, INC., SOUTHLAKE, TX. FILED 4-11-2011.

PURESANA

THE MARK CONSISTS OF STANDARD CHARACTERS WITHOUT CLAIM TO ANY PARTICULAR FONT, STYLE, SIZE, OR COLOR.

FOR BEAUTY SALON FURNITURE (U.S. CLS. 2, 13, 22, 25, 32 AND 50).

ANDREW LEASER, EXAMINING ATTORNEY

SN 85-292,785. DATUMZERO DESIGN OFFICE INC, NEW YORK, NY. FILED 4-12-2011.

LOT 61

THE MARK CONSISTS OF STANDARD CHARACTERS WITHOUT CLAIM TO ANY PARTICULAR FONT, STYLE, SIZE, OR COLOR.

FOR FURNITURE (U.S. CLS. 2, 13, 22, 25, 32 AND 50).
FIRST USE 0-0-2009; IN COMMERCE 0-0-2009.

ZACHARY BELLO, EXAMINING ATTORNEY

CLASS 20—(Continued).

SN 85-293,642. HICKORY SPRINGS MANUFACTURING COMPANY, HICKORY, NC. FILED 4-13-2011.

INCHEX

THE MARK CONSISTS OF STANDARD CHARACTERS WITHOUT CLAIM TO ANY PARTICULAR FONT, STYLE, SIZE, OR COLOR.

FOR MATTRESS INNERSPRING ASSEMBLY, NAMELY, A NETWORK OF A PLURALITY OF COIL SPRINGS INTERCONNECTED TOGETHER (U.S. CLS. 2, 13, 22, 25, 32 AND 50).

ALLISON HOLTZ, EXAMINING ATTORNEY

SN 85-293,771. BOYD FLOTATION, INC., MARYLAND HEIGHTS, MO. FILED 4-13-2011.

Contour Sense

THE MARK CONSISTS OF STANDARD CHARACTERS WITHOUT CLAIM TO ANY PARTICULAR FONT, STYLE, SIZE, OR COLOR.

FOR AIR MATTRESSES FOR USE WHEN CAMPING; BEDS, MATTRESSES, PILLOWS AND BOLSTERS; INFLATABLE MATTRESSES FOR USE WHEN CAMPING; MATTRESS FOUNDATIONS; MATTRESS TOPPERS; MATTRESSES; MATTRESSES AND PILLOWS; SLEEP PRODUCTS, NAMELY, MATTRESSES, SPRING MATTRESSES, BOX SPRINGS AND MATTRESS FOUNDATIONS (U.S. CLS. 2, 13, 22, 25, 32 AND 50).

TEJBIR SINGH, EXAMINING ATTORNEY

SN 85-293,800. BOYD FLOTATION, INC, MARYLAND HEIGHTS, MO. FILED 4-13-2011.

Eco Sense

THE MARK CONSISTS OF STANDARD CHARACTERS WITHOUT CLAIM TO ANY PARTICULAR FONT, STYLE, SIZE, OR COLOR.

FOR AIR MATTRESSES FOR USE WHEN CAMPING; BEDS, MATTRESSES, PILLOWS AND BOLSTERS; INFLATABLE MATTRESSES FOR USE WHEN CAMPING; MATTRESS FOUNDATIONS; MATTRESS TOPPERS; MATTRESSES; MATTRESSES AND PILLOWS; SLEEP PRODUCTS, NAMELY, MATTRESSES, SPRING MATTRESSES, BOX SPRINGS AND MATTRESS FOUNDATIONS (U.S. CLS. 2, 13, 22, 25, 32 AND 50).

KEVIN CORWIN, EXAMINING ATTORNEY

CLASS 20—(Continued).

SN 85-295,675. NOYES ART DESIGNS, DENVER, CO. FILED 4-14-2011.



THE STIPPLING IS FOR SHADING PURPOSES ONLY. THE MARK CONSISTS OF THE TEXT "MAIL'ABLES" ACROSS A SKY WITH CLOUDS AT THE BOTTOM AND SKY ABOVE. THE PHOTO IS SURROUNDED BY A BORDER THAT RESEMBLES A STAMP.

FOR WORKS OF ART OF WOOD (U.S. CLS. 2, 13, 22, 25, 32 AND 50).

JOHN HWANG, EXAMINING ATTORNEY

SN 85-307,804. WEISS, DAVID, I., PLANTATION, FL. FILED 4-28-2011.

FEEL & SEAL

THE MARK CONSISTS OF STANDARD CHARACTERS WITHOUT CLAIM TO ANY PARTICULAR FONT, STYLE, SIZE, OR COLOR.

NO CLAIM IS MADE TO THE EXCLUSIVE RIGHT TO USE "SEAL", APART FROM THE MARK AS SHOWN.

FOR PLASTIC LIDS (U.S. CLS. 2, 13, 22, 25, 32 AND 50).

SANDRA BUJA, EXAMINING ATTORNEY

SN 85-339,484. LEXINGTON FURNITURE INDUSTRIES, INC., DBA LEXINGTON HOME BRANDS, THOMASVILLE, NC. FILED 6-7-2011.

QUAIL HOLLOW

THE MARK CONSISTS OF STANDARD CHARACTERS WITHOUT CLAIM TO ANY PARTICULAR FONT, STYLE, SIZE, OR COLOR.

FOR FURNITURE (U.S. CLS. 2, 13, 22, 25, 32 AND 50).

MARK SPARACINO, EXAMINING ATTORNEY

CLASS 20—(Continued).

SN 85-343,130. KELLWOOD COMPANY, CHESTERFIELD, MO. FILED 6-10-2011.

MY MICHELLE

THE MARK CONSISTS OF STANDARD CHARACTERS WITHOUT CLAIM TO ANY PARTICULAR FONT, STYLE, SIZE, OR COLOR.

OWNER OF U.S. REG. NO. 1,442,190.
FOR ACCENT PILLOWS; BED PILLOWS; PILLOWS (U.S. CLS. 2, 13, 22, 25, 32 AND 50).
EUGENIA MARTIN, EXAMINING ATTORNEY

CLASS 21—(Continued).

SN 85-102,924. MARC STEVENSON, EDMONTON, ALBERTA, CANADA, FILED 8-9-2010.

GRIP CADDIE

THE MARK CONSISTS OF STANDARD CHARACTERS WITHOUT CLAIM TO ANY PARTICULAR FONT, STYLE, SIZE, OR COLOR.

NO CLAIM IS MADE TO THE EXCLUSIVE RIGHT TO USE "GRIP", APART FROM THE MARK AS SHOWN.

FOR PORTABLE CLEANING BRUSH FOR GOLF GRIPS CONTAINED IN A FITTED HOUSING (U.S. CLS. 2, 13, 23, 29, 30, 33, 40 AND 50).
JULIE WATSON, EXAMINING ATTORNEY

SN 85-105,425. OMS INVESTMENTS, INC., LOS ANGELES, CA. FILED 8-11-2010.

CLASS 21—HOUSEWARES AND GLASS

SN 78-696,330. GUY, GEORGE B., CHICAGO, IL. FILED 8-19-2005.

LEGENDS

THE MARK CONSISTS OF STANDARD CHARACTERS WITHOUT CLAIM TO ANY PARTICULAR FONT, STYLE, SIZE, OR COLOR.

FOR COFFEE MUGS AND SHOT GLASSES (U.S. CLS. 2, 13, 23, 29, 30, 33, 40 AND 50).
FIRST USE 6-0-1989; IN COMMERCE 6-0-1989.
PATRICIA EVANKO, EXAMINING ATTORNEY

SMART SOLUTIONS

THE MARK CONSISTS OF STANDARD CHARACTERS WITHOUT CLAIM TO ANY PARTICULAR FONT, STYLE, SIZE, OR COLOR.

FOR MULTI-USE HOSE END SPRAYERS FOR SPRAYING PESTICIDES, INSECTICIDES, HERBICIDES, AND FERTILIZERS; HOSE-END TRIGGER SPRAYERS FOR SPRAYING PESTICIDES, INSECTICIDES, HERBICIDES, AND FERTILIZERS; DISPENSER FOR APPLYING READY-TO-USE CHEMICALS, NAMELY, A MANUALLY ACTUATED PUMP DISPENSER CONNECTED TO AN APPLICATOR WAND NOZZLE; PEST REPELLENT DEVICES, NAMELY, FLYING INSECT TRAPS, ANT TRAPS (U.S. CLS. 2, 13, 23, 29, 30, 33, 40 AND 50).
KAREN K. BUSH, EXAMINING ATTORNEY

SN 85-141,948. TABLETOPS UNLIMITED, INC., CARSON, CA. FILED 9-30-2010.

**TABLETOPS GALLERY TIMELESS
DESIGNS SINCE 1983**

SN 85-043,148. CEDAR WORKS, LLC, PEBBLES, OH. FILED 5-19-2010.

ALLSEED

THE MARK CONSISTS OF STANDARD CHARACTERS WITHOUT CLAIM TO ANY PARTICULAR FONT, STYLE, SIZE, OR COLOR.

SEC. 2(F).
FOR BIRD FEEDERS (U.S. CLS. 2, 13, 23, 29, 30, 33, 40 AND 50).
FIRST USE 7-20-2001; IN COMMERCE 12-0-2004.
MARK SHINER, EXAMINING ATTORNEY

THE MARK CONSISTS OF STANDARD CHARACTERS WITHOUT CLAIM TO ANY PARTICULAR FONT, STYLE, SIZE, OR COLOR.

OWNER OF U.S. REG. NOS. 1,797,554, 3,422,945 AND OTHERS.

NO CLAIM IS MADE TO THE EXCLUSIVE RIGHT TO USE "DESIGNS SINCE 1983", APART FROM THE MARK AS SHOWN.

FOR DINNERWARE, PLATES, BOWLS, MUGS, CASEROLE DISHES, CUTTING BOARDS, BAKING DISHES, SERVING DISHES, GRAVY BOATS, BREAD BASKETS FOR DOMESTIC USE, AND CANISTER SETS (U.S. CLS. 2, 13, 23, 29, 30, 33, 40 AND 50).
ROSELLE HERRERA, EXAMINING ATTORNEY

CLASS 21—(Continued).

SN 85-145,162. CAPITOL TEA COMPANY, LLC, BISMARCK, ND. FILED 10-5-2010.



THE COLOR(S) LIGHT GREEN, DARK GREEN AND BLACK IS/ARE CLAIMED AS A FEATURE OF THE MARK. THE MARK CONSISTS OF A DARK GREEN TEA LEAF PORTRAYED ON A LIGHT GREEN CIRCLE, ACCOMPANIED BY THE WORDS "STEEP ME A CUP OF TEA" IN BLACK.

FOR TEA INFUSERS (U.S. CLS. 2, 13, 23, 29, 30, 33, 40 AND 50).

FIRST USE 7-8-2008; IN COMMERCE 7-9-2008.

DORITT L. CARROLL, EXAMINING ATTORNEY

CLASS 21—(Continued).

SN 85-211,876. GOURMET WORKS MANUFACTURING CO., LTD., ZHONGSHAN, GUANGDONG, CHINA, FILED 1-6-2011.

gourmetworks
cookware

NO CLAIM IS MADE TO THE EXCLUSIVE RIGHT TO USE "COOKWARE", APART FROM THE MARK AS SHOWN.

THE COLOR(S) YELLOW, RED AND BLACK IS/ARE CLAIMED AS A FEATURE OF THE MARK.

THE MARK CONSISTS OF THE WORDING "GOURMET-WORKS COOKWARE" WITH THE WORDING "GOURMET" IN YELLOW WITH BLACK OUTLINES, THE WORDING "WORKS" IN RED, AND THE WORDING "COOKWARE" UNDERNEATH IN BLACK.

FOR COOKING WARES AND COOKING UTENSILS, NAMELY, POTS, PANS, WOKS, KETTLES, GRILLS (U.S. CLS. 2, 13, 23, 29, 30, 33, 40 AND 50).

JANET LEE, EXAMINING ATTORNEY

SN 85-228,901. WESMILL INC., HOFFMAN ESTATES, IL. FILED 1-28-2011.

Nipple Shots

THE MARK CONSISTS OF STANDARD CHARACTERS WITHOUT CLAIM TO ANY PARTICULAR FONT, STYLE, SIZE, OR COLOR.

NO CLAIM IS MADE TO THE EXCLUSIVE RIGHT TO USE "SHOTS", APART FROM THE MARK AS SHOWN.

FOR BOTTLES, SOLD EMPTY (U.S. CLS. 2, 13, 23, 29, 30, 33, 40 AND 50).

ROBERT C. CLARK JR., EXAMINING ATTORNEY

SN 85-170,891. ICEY-TEK PTY. LTD., TWEED HEADS, NSW, AUSTRALIA, FILED 11-6-2010.

ICEY-TEK

SN 85-258,546. ALF OPERATING PARTNER LP, FORT WORTH, TX. FILED 3-4-2011.

UltraFiber

THE MARK CONSISTS OF STANDARD CHARACTERS WITHOUT CLAIM TO ANY PARTICULAR FONT, STYLE, SIZE, OR COLOR.

FOR PORTABLE COOLERS (U.S. CLS. 2, 13, 23, 29, 30, 33, 40 AND 50).

MICHAEL ENGEL, EXAMINING ATTORNEY

THE MARK CONSISTS OF STANDARD CHARACTERS WITHOUT CLAIM TO ANY PARTICULAR FONT, STYLE, SIZE, OR COLOR.

FOR RAISED GARDEN BEDS, NAMELY, RAISED CONTAINERS FOR PLANTING CONTAINED GARDENS (U.S. CLS. 2, 13, 23, 29, 30, 33, 40 AND 50).

ARETHA SOMERVILLE, EXAMINING ATTORNEY

CLASS 21—(Continued).

SN 85-264,965. SLY BOARD COMPANY, NORTH MIAMI BEACH, FL. FILED 3-11-2011.

L'BORD

THE MARK CONSISTS OF STANDARD CHARACTERS WITHOUT CLAIM TO ANY PARTICULAR FONT, STYLE, SIZE, OR COLOR.

FOR CUTTING BOARDS (U.S. CLS. 2, 13, 23, 29, 30, 33, 40 AND 50).

RON FAIRBANKS, EXAMINING ATTORNEY

SN 85-271,706. DEPHILLIPPO, ASHLEE, TEMECULA, CA. FILED 3-20-2011.

Bob Barley

THE MARK CONSISTS OF STANDARD CHARACTERS WITHOUT CLAIM TO ANY PARTICULAR FONT, STYLE, SIZE, OR COLOR.

THE NAME(S), PORTRAIT(S), AND/OR SIGNATURE(S) SHOWN IN THE MARK DOES NOT IDENTIFY A PARTICULAR LIVING INDIVIDUAL.

FOR PLANTERS FOR FLOWERS AND PLANTS (U.S. CLS. 2, 13, 23, 29, 30, 33, 40 AND 50).

LINDA POWELL, EXAMINING ATTORNEY

SN 85-275,269. CORNING INCORPORATED, CORNING, NY. FILED 3-24-2011.

CORNING LOTUS

THE MARK CONSISTS OF STANDARD CHARACTERS WITHOUT CLAIM TO ANY PARTICULAR FONT, STYLE, SIZE, OR COLOR.

OWNER OF U.S. REG. NOS. 618,649, 1,748,228 AND OTHERS.

SEC. 2(F) AS TO "CORNING".

FOR SEMI-FINISHED SUBSTRATES MADE PRIMARILY OF GLASS FOR USE IN THE MANUFACTURE OF INFORMATIONAL DISPLAYS COMPRISED OF ORGANIC LIGHT-EMITTING DIODES (OLEDs) (U.S. CLS. 2, 13, 23, 29, 30, 33, 40 AND 50).

MICHAEL TANNER, EXAMINING ATTORNEY

CLASS 21—(Continued).

SN 85-277,584. DALE CHIHULY, SEATTLE, WA. FILED 3-25-2011.

CHIHULY

THE MARK CONSISTS OF STANDARD CHARACTERS WITHOUT CLAIM TO ANY PARTICULAR FONT, STYLE, SIZE, OR COLOR.

OWNER OF U.S. REG. NOS. 2,418,814, 2,682,143 AND OTHERS.

FOR SCULPTURES MADE PRIMARILY OF GLASS (U.S. CLS. 2, 13, 23, 29, 30, 33, 40 AND 50).

FIRST USE 12-31-1959; IN COMMERCE 12-31-1959.

KELLEY WELLS, EXAMINING ATTORNEY

SN 85-280,355. TSOU, PETER CHRISTIAN, SAN FRANCISCO, CA. FILED 3-29-2011.

schatzii

THE MARK CONSISTS OF STANDARD CHARACTERS WITHOUT CLAIM TO ANY PARTICULAR FONT, STYLE, SIZE, OR COLOR.

THE WORDING "SCHATZII" HAS NO MEANING IN A FOREIGN LANGUAGE.

FOR SCREEN CLEANING CLOTH (U.S. CLS. 2, 13, 23, 29, 30, 33, 40 AND 50).

JEFFERY COWARD, EXAMINING ATTORNEY

SN 85-283,783. MIKE GRONHOLM, MILWAUKEE, OR. FILED 4-1-2011.

EXACTA-K

THE MARK CONSISTS OF STANDARD CHARACTERS WITHOUT CLAIM TO ANY PARTICULAR FONT, STYLE, SIZE, OR COLOR.

FOR DISPENSERS FOR STORING AND DISPENSING SOLID, DRY GRANULES OF COFFEE, TEA, COCOA, OR APPLE CIDER INTO A REUSABLE, SINGLE SERVING CONTAINER COMPATIBLE WITH BEVERAGE BREWING DEVICES (U.S. CLS. 2, 13, 23, 29, 30, 33, 40 AND 50).

REGINA DRUMMOND, EXAMINING ATTORNEY

CLASS 21—(Continued).

SN 85-286,414. FERGUSON ENTERPRISES, INC., NEWPORT NEWS, VA. FILED 4-5-2011.

SOPHISTISPA

THE MARK CONSISTS OF STANDARD CHARACTERS WITHOUT CLAIM TO ANY PARTICULAR FONT, STYLE, SIZE, OR COLOR.

FOR BATHROOM ACCESSORIES, NAMELY, TOWEL BARS, TOWEL RINGS, TOWEL RAILS, TOILET TISSUE HOLDERS, TOOTHBRUSH HOLDERS, CUP HOLDERS, BATHROOM GLASS HOLDERS NOT OF PRECIOUS METAL, SOAP DISHES, SOAP DISPENSERS, AND SHOWER BASKETS IN THE NATURE OF SHOWER CADDIES (U.S. CLS. 2, 13, 23, 29, 30, 33, 40 AND 50).
LAURIE MAYES, EXAMINING ATTORNEY

CLASS 21—(Continued).

SN 85-291,386. NINTENDO OF AMERICA INC., REDMOND, WA. FILED 4-11-2011.



THE MARK CONSISTS OF A SOLID INNER CIRCLE, ENCLOSED WITHIN A FIRST INNER ANNULUS WHICH IN TURN IS ENCLOSED WITHIN A SECOND OUTER ANNULUS, WHICH IN TURN IS ENCLOSED BY A THICKER OUTER CIRCLE THAT IS DIVIDED BY A HORIZONTAL LINE. PORTIONS OF THE UPPER AND LOWER HALVES OF THE OUTER CIRCLE ARE SHADED.

FOR CUPS; ELECTRIC AND NON-ELECTRIC TOOTHBRUSHES; INSULATED CONTAINERS FOR FOOD OR BEVERAGE; LUNCH BOXES; LUNCH PAILS; MUGS; PLASTIC CUPS; TOOTHBRUSHES (U.S. CLS. 2, 13, 23, 29, 30, 33, 40 AND 50).

B. PARADEWELAI, EXAMINING ATTORNEY

SN 85-291,757. HOME DYNAMIX LLC., MOONACHIE, NJ. FILED 4-11-2011.

DYNAMIX SOLUTIONS

THE MARK CONSISTS OF STANDARD CHARACTERS WITHOUT CLAIM TO ANY PARTICULAR FONT, STYLE, SIZE, OR COLOR.

FOR COLLAPSIBLE STORAGE CONTAINERS FOR DOMESTIC USE (U.S. CLS. 2, 13, 23, 29, 30, 33, 40 AND 50).

TIMOTHY FINNEGAN, EXAMINING ATTORNEY

SN 85-291,794. FOCUS PRODUCTS GROUP LLC, LINCOLNSHIRE, IL. FILED 4-11-2011.

ELECTRONIC NATION

FILL N' GRILL

THE MARK CONSISTS OF STANDARD CHARACTERS WITHOUT CLAIM TO ANY PARTICULAR FONT, STYLE, SIZE, OR COLOR.

FOR MUGS (U.S. CLS. 2, 13, 23, 29, 30, 33, 40 AND 50).
DAVID HOFFMAN, EXAMINING ATTORNEY

THE MARK CONSISTS OF STANDARD CHARACTERS WITHOUT CLAIM TO ANY PARTICULAR FONT, STYLE, SIZE, OR COLOR.

FOR NON-ELECTRIC PATTY MAKER (U.S. CLS. 2, 13, 23, 29, 30, 33, 40 AND 50).

FIRST USE 11-0-2010; IN COMMERCE 11-0-2010.

KARANENDRA S. CHHINA, EXAMINING ATTORNEY

CLASS 21—(Continued).

SN 85-292,676. BONA AB, SE-200 21 MALMÖ, SWEDEN, FILED 4-12-2011.

CURVE

THE MARK CONSISTS OF STANDARD CHARACTERS WITHOUT CLAIM TO ANY PARTICULAR FONT, STYLE, SIZE, OR COLOR.

FOR FLOOR MOPS (U.S. CLS. 2, 13, 23, 29, 30, 33, 40 AND 50).

ELIZABETH KAJUBI, EXAMINING ATTORNEY

CLASS 21—(Continued).

SN 85-295,332. HUTZLER MANUFACTURING COMPANY, INC., CANAAN, CT. FILED 4-14-2011.

Pro-Line Savers

THE MARK CONSISTS OF STANDARD CHARACTERS WITHOUT CLAIM TO ANY PARTICULAR FONT, STYLE, SIZE, OR COLOR.

FOR PLASTIC CONTAINERS IN THE SHAPE OF FRUITS AND VEGETABLES FOR STORING INDIVIDUAL FRUITS AND VEGETABLES, AND FOR EXTENDING THE LIFE OF THOSE FRUITS AND VEGETABLES (U.S. CLS. 2, 13, 23, 29, 30, 33, 40 AND 50).

FIRST USE 1-1-2010; IN COMMERCE 8-1-2010.
ALLISON HOLTZ, EXAMINING ATTORNEY

SN 85-292,780. BONA AB, SE-200 21 MALMÖ, SWEDEN, FILED 4-12-2011.

MOTION

THE MARK CONSISTS OF STANDARD CHARACTERS WITHOUT CLAIM TO ANY PARTICULAR FONT, STYLE, SIZE, OR COLOR.

FOR FLOOR MOPS (U.S. CLS. 2, 13, 23, 29, 30, 33, 40 AND 50).

ELIZABETH KAJUBI, EXAMINING ATTORNEY

SN 85-300,083. SPORNETTE INTERNATIONAL, INC., HOMEWOOD, IL. FILED 4-20-2011.

THE FEEL GOOD BRUSH

THE MARK CONSISTS OF STANDARD CHARACTERS WITHOUT CLAIM TO ANY PARTICULAR FONT, STYLE, SIZE, OR COLOR.

NO CLAIM IS MADE TO THE EXCLUSIVE RIGHT TO USE "BRUSH", APART FROM THE MARK AS SHOWN.

FOR HAIR BRUSHES AND COMBS (U.S. CLS. 2, 13, 23, 29, 30, 33, 40 AND 50).

FIRST USE 6-30-2010; IN COMMERCE 6-30-2010.
CHRIS WELLS, EXAMINING ATTORNEY

SN 85-293,499. VALENTINE, ERICA, NAPA, CA. FILED 4-12-2011.

Hydrafy

THE MARK CONSISTS OF STANDARD CHARACTERS WITHOUT CLAIM TO ANY PARTICULAR FONT, STYLE, SIZE, OR COLOR.

FOR BOTTLES, SOLD EMPTY (U.S. CLS. 2, 13, 23, 29, 30, 33, 40 AND 50).

MARK RADEMACHER, EXAMINING ATTORNEY

SN 85-302,165. CRAYOLA PROPERTIES, INC., EASTON, PA. FILED 4-22-2011.

CRAYON CRUNCHER

THE MARK CONSISTS OF STANDARD CHARACTERS WITHOUT CLAIM TO ANY PARTICULAR FONT, STYLE, SIZE, OR COLOR.

NO CLAIM IS MADE TO THE EXCLUSIVE RIGHT TO USE "CRAYON", APART FROM THE MARK AS SHOWN.

FOR HAND OPERATED PLASTIC DEVICE FOR GRINDING CRAYONS (U.S. CLS. 2, 13, 23, 29, 30, 33, 40 AND 50).

TOBY BULLOFF, EXAMINING ATTORNEY

CLASS 21—(Continued).

SN 85-306,742. ORE ORIGINALS, INC., LONG BEACH, CA. FILED 4-28-2011.



OWNER OF U.S. REG. NOS. 3,690,658, 3,690,728 AND 3,690,733.

THE MARK CONSISTS OF THE DESIGN OF A BABY WITH TOOTH, HAIR AND STAR.

FOR BOWLS; CUPS; PLATES (U.S. CLS. 2, 13, 23, 29, 30, 33, 40 AND 50).

FIRST USE 1-1-2009; IN COMMERCE 1-1-2009.

JERI J. FICKES, EXAMINING ATTORNEY

SN 85-309,165. KOLLER ENTERPRISES, INC., DBA HAWKEYE INTERNATIONAL, SHAWNEE, KS. FILED 4-30-2011.

PANAVIEW

THE MARK CONSISTS OF STANDARD CHARACTERS WITHOUT CLAIM TO ANY PARTICULAR FONT, STYLE, SIZE, OR COLOR.

FOR AQUARIUMS (U.S. CLS. 2, 13, 23, 29, 30, 33, 40 AND 50).

TRACY FLETCHER, EXAMINING ATTORNEY

SN 85-325,625. KIMBERLY-CLARK WORLDWIDE, INC., NEENAH, WI. FILED 5-20-2011.

MOD

THE MARK CONSISTS OF STANDARD CHARACTERS WITHOUT CLAIM TO ANY PARTICULAR FONT, STYLE, SIZE, OR COLOR.

FOR DISPENSERS FOR PAPER TOWELS, PAPER TISSUE AND SKIN CARE SOAPS AND CLEANSERS (U.S. CLS. 2, 13, 23, 29, 30, 33, 40 AND 50).

JOHN HWANG, EXAMINING ATTORNEY

CLASS 21—(Continued).

SN 85-327,805. IGLOO PRODUCTS CORP., KATY, TX. FILED 5-23-2011.



OWNER OF U.S. REG. NOS. 718,413, 961,185 AND 3,454,203.

NO CLAIM IS MADE TO THE EXCLUSIVE RIGHT TO USE "OUTDOORS", APART FROM THE MARK AS SHOWN.

THE MARK CONSISTS OF A STYLIZED IMAGE OF A UNSHADED TREE, BRANCHES AND LEAVES, ON A PARTIALLY SHADED BACKGROUND, WITH A STYLIZED IGLOO HOUSE TO THE RIGHT, CONSISTING OF A HALF CIRCLE AND TWO ARCHES, ONE SHADED AND ONE UNSHADED EXTENDING OUT FROM THE HALF CIRCLE, WITH THE WORDING, "IGLOO" INSIDE A RECTANGLE WITH ONE CURVED CORNER BELOW, AND WITH THE WORDING, "OUTDOORS" INSIDE A RECTANGLE, BELOW "IGLOO".

FOR PORTABLE CONTAINERS FOR ICE, FOOD, AND BEVERAGES (U.S. CLS. 2, 13, 23, 29, 30, 33, 40 AND 50).
ODESSA BIBBINS, EXAMINING ATTORNEY

SN 85-344,636. BARILLA G. E R. FRATELLI - SOCIETÀ PER AZIONI, PARMA, ITALY, FILED 6-13-2011.

SPAGHETTATA

THE MARK CONSISTS OF STANDARD CHARACTERS WITHOUT CLAIM TO ANY PARTICULAR FONT, STYLE, SIZE, OR COLOR.

FOR CHEESE GRATERS; COLANDERS; PLASTIC PASTA STORAGE CONTAINERS FOR HOUSEHOLD USE; COOKWARE, NAMELY, PASTA COOKING POTS; DINNERWARE; DISHWARE; PLATES; MUGS; BOWLS; TABLE PLACE CARD HOLDERS NOT OF PRECIOUS METAL; HOUSEHOLD UTENSILS, NAMELY, STRAINERS, COLANDER (U.S. CLS. 2, 13, 23, 29, 30, 33, 40 AND 50).

AISHA CLARKE, EXAMINING ATTORNEY

CLASS 22—CORDAGE AND FIBERS

SN 85-273,247. GAINES, RICHARD, BRECKENRIDGE, MI.
FILED 3-22-2011.



NO CLAIM IS MADE TO THE EXCLUSIVE RIGHT TO USE "LOCK", APART FROM THE MARK AS SHOWN.
THE MARK CONSISTS OF THE STYLIZED TEXT "LOCK SOCK" WITH A LOCK IN THE MIDDLE.
FOR WATERPROOF AND WIND-RESISTANT UNFITTED NYLON FABRIC COVER FOR PADLOCKS TO PREVENT RUST AND FREEZING AND EXPOSURE TO RAIN AND SNOW (U.S. CLS. 1, 2, 7, 19, 22, 42 AND 50).
CHRISTINE COOPER, EXAMINING ATTORNEY

SN 85-275,072. EDWARD JOSEPH POZZI, AKA POZZI RANCH, BODEGA, CA. FILED 3-23-2011.

PUREGROW WOOL

THE MARK CONSISTS OF STANDARD CHARACTERS WITHOUT CLAIM TO ANY PARTICULAR FONT, STYLE, SIZE, OR COLOR.
NO CLAIM IS MADE TO THE EXCLUSIVE RIGHT TO USE "WOOL", APART FROM THE MARK AS SHOWN.
FOR SUSTAINABLY PRODUCED WOOL FOR THE BEDDING INDUSTRY (U.S. CLS. 1, 2, 7, 19, 22, 42 AND 50).
FIRST USE 5-10-1993; IN COMMERCE 5-10-1993.
MICHAEL GAAFAR, EXAMINING ATTORNEY

SN 85-275,078. EDWARD JOSEPH POZZI, AKA POZZI RANCH, BODEGA, CA. FILED 3-23-2011.

POZZI WOOL

THE MARK CONSISTS OF STANDARD CHARACTERS WITHOUT CLAIM TO ANY PARTICULAR FONT, STYLE, SIZE, OR COLOR.
NO CLAIM IS MADE TO THE EXCLUSIVE RIGHT TO USE "WOOL", APART FROM THE MARK AS SHOWN.
SEC. 2(F).
FOR SUSTAINABLY PRODUCED WOOL FOR THE BEDDING INDUSTRY (U.S. CLS. 1, 2, 7, 19, 22, 42 AND 50).
FIRST USE 6-1-1993; IN COMMERCE 6-1-1993.
MICHAEL GAAFAR, EXAMINING ATTORNEY

CLASS 22—(Continued).

SN 85-289,721. LIANG, DANIEL, AKA LIANG, CHIA TUNG, CERRITOS, CA. FILED 4-8-2011.

Mega Straps

THE MARK CONSISTS OF STANDARD CHARACTERS WITHOUT CLAIM TO ANY PARTICULAR FONT, STYLE, SIZE, OR COLOR.
NO CLAIM IS MADE TO THE EXCLUSIVE RIGHT TO USE "STRAPS", APART FROM THE MARK AS SHOWN.
FOR CARGO AND CARRIER EQUIPMENT FOR VEHICLES, NAMELY, TOW ROPES, TOW STRAPS, RATCHET TIE-DOWN STRAPS, QUICK RELEASE TIE DOWN STRAPS, LASHING STRAPS, AND TARP STRAPS (U.S. CLS. 1, 2, 7, 19, 22, 42 AND 50).
B. PARADEWELAI, EXAMINING ATTORNEY

SN 85-289,729. LIANG, DANIEL, AKA LIANG, CHIA TUNG, CERRITOS, CA. FILED 4-8-2011.

Tie Safe Straps

THE MARK CONSISTS OF STANDARD CHARACTERS WITHOUT CLAIM TO ANY PARTICULAR FONT, STYLE, SIZE, OR COLOR.
NO CLAIM IS MADE TO THE EXCLUSIVE RIGHT TO USE "TIE" AND "STRAPS", APART FROM THE MARK AS SHOWN.
FOR CARGO AND CARRIER EQUIPMENT FOR VEHICLES, NAMELY, TOW ROPES, TOW STRAPS, RATCHET TIE-DOWN STRAPS, QUICK RELEASE TIE DOWN STRAPS, LASHING STRAPS, AND TARP STRAPS (U.S. CLS. 1, 2, 7, 19, 22, 42 AND 50).
B. PARADEWELAI, EXAMINING ATTORNEY

SN 85-339,064. GLEN RAVEN, INC., GLEN RAVEN, NC. FILED 6-6-2011.

SOLAIR COMFORT

THE MARK CONSISTS OF STANDARD CHARACTERS WITHOUT CLAIM TO ANY PARTICULAR FONT, STYLE, SIZE, OR COLOR.
OWNER OF U.S. REG. NOS. 1,181,824 AND 3,660,882.
FOR RETRACTABLE AWNINGS (U.S. CLS. 1, 2, 7, 19, 22, 42 AND 50).
FIRST USE 11-0-2008; IN COMMERCE 11-0-2008.
ROSELLE HERRERA, EXAMINING ATTORNEY

CLASS 23—YARNS AND THREADS

SN 85-313,981, J. & P. COATS, LIMITED, GLASGOW, UNITED KINGDOM, FILED 5-6-2011.

KISS

THE MARK CONSISTS OF STANDARD CHARACTERS WITHOUT CLAIM TO ANY PARTICULAR FONT, STYLE, SIZE, OR COLOR.

FOR YARNS AND THREADS FOR KNITTING, SEWING AND CROCHETING (U.S. CL. 43).
CHERYL CLAYTON, EXAMINING ATTORNEY

CLASS 24—FABRICS

SN 76-707,226, JAY FRANCO & SONS, INC., NEW YORK, NY. FILED 4-12-2011.

PILLOWTIME PLAY PALS

THE MARK CONSISTS OF STANDARD CHARACTERS WITHOUT CLAIM TO ANY PARTICULAR FONT, STYLE, SIZE, OR COLOR.

FOR BED SHEETS, PILLOW CASES, BATH TOWELS, HAND TOWELS, WASH CLOTHS, KITCHEN TOWELS, DISH TOWELS, TEXTILE POT HOLDERS, OVEN MITTS, TEXTILE PLACEMATS, BEACH TOWELS, AND SHOWER CURTAINS (U.S. CLS. 42 AND 50).
PAM WILLIS, EXAMINING ATTORNEY

SN 77-706,208, LONDON LUXURY LLC, NEW ROCHELLE, NY. FILED 4-3-2009.

FLEX TOWEL

THE MARK CONSISTS OF STANDARD CHARACTERS WITHOUT CLAIM TO ANY PARTICULAR FONT, STYLE, SIZE, OR COLOR.

NO CLAIM IS MADE TO THE EXCLUSIVE RIGHT TO USE "TOWEL", APART FROM THE MARK AS SHOWN.
FOR TOWELS (U.S. CLS. 42 AND 50).
EMILY CHUO, EXAMINING ATTORNEY

CLASS 24—(Continued).

SN 77-769,894, VINTEX INC., MOUNT FOREST, ONTARIO, CANADA, FILED 6-29-2009.

SAFE GUARD BARRIER SYSTEMS

THE MARK CONSISTS OF STANDARD CHARACTERS WITHOUT CLAIM TO ANY PARTICULAR FONT, STYLE, SIZE, OR COLOR.

PRIORITY CLAIMED UNDER SEC. 44(D) ON CANADA APPLICATION NO. 1441696, FILED 6-16-2009, REG. NO. TMA800.030, DATED 6-16-2011, EXPIRES 6-16-2026.

NO CLAIM IS MADE TO THE EXCLUSIVE RIGHT TO USE "BARRIER SYSTEMS", APART FROM THE MARK AS SHOWN.

FOR FABRICS COATED WITH THERMAL PLASTIC COATING FOR USE IN THE MANUFACTURE OF GOODS USED IN HOMES, HEALTH CARE FACILITIES, HOSPITALS, ASSISTED LIVING, NURSING HOMES, DORMITORIES, AND CORRECTIONAL FACILITIES, NAMELY, ABSORBENT INCONTINENCE PADS, LAUNDRY BAGS, ADULT DIAPERS, MATTRESS TICKING AND BED PILLOWS (U.S. CLS. 42 AND 50).
MARLENE BELL, EXAMINING ATTORNEY

SN 79-088,090, ZHEJIANG ZHENYA INDUSTRIAL GROUP CO., LTD., CHINA, FILED 9-23-2010.



OWNER OF INTERNATIONAL REGISTRATION 1053134 DATED 9-23-2010, EXPIRES 9-23-2020.

THE MARK CONSISTS OF THE GREEK LETTER "PSI" IN THE NATURE OF AN "IU" DESIGN FEATURING A CAPITAL "I" BISECTING A STYLIZED "U". SUCH GREEK LETTER OR DESIGN BEING WITHIN A CIRCLE THAT IS ITSELF WITHIN AN OVAL, ALL THE ABOVE BEING SUPERIMPOSED ON A QUADRILATERAL DESIGN

FOR CLOTH, NAMELY, TEXTILE TABLE CLOTHS, DISH CLOTHS, WASH CLOTHS, TEXTILE USED AS LINING FOR CLOTHING; POLYESTER FABRICS; STATIC FLOCKING CLOTH; TRACED CLOTH FOR EMBROIDERY; GUNNY CLOTH; PRINTED CALICO CLOTH; WOOLLEN CLOTH; LINEN CLOTH; OXFORD CLOTH; CANVAS FOR TAPESTRY OR EMBROIDERY (U.S. CLS. 42 AND 50).
STEVEN R. FINE, EXAMINING ATTORNEY

CLASS 24—(Continued).

SN 79-090,322. GUANGDONG JINLIAN WINDOW FASHION CO.,LTD, CHINA, FILED 11-12-2010.

JIN LIAN 金联

OWNER OF INTERNATIONAL REGISTRATION 1059380 DATED 11-12-2010, EXPIRES 11-12-2020.

NO CLAIM IS MADE TO THE EXCLUSIVE RIGHT TO USE "JIN" AND THE NON-LATIN CHARACTERS THAT TRANSLITERATE TO "JIN", APART FROM THE MARK AS SHOWN.

THE MARK CONSISTS OF THE STYLIZED WORDS "JIN LIAN" TO THE LEFT OF TWO CHINESE CHARACTERS WITH A TRANSLITERATION OF "JIN LIAN".

THE ENGLISH TRANSLATION OF THE FOREIGN WORD(S) IN THE MARK IS: GOLDEN UNION.

THE TRANSLITERATION OF THE NON-LATIN CHARACTERS IN THE MARK IS: "JIN LIAN".

FOR CURTAINS MADE OF TEXTILE FABRICS; CURTAINS; CURTAINS OF TEXTILE OR PLASTIC; NET CURTAINS; BED COVERS; QUILTS; BED SHEETS; BED BLANKETS; MOSQUITO NETS (U.S. CLS. 42 AND 50).

MARY BOAGNI, EXAMINING ATTORNEY

SN 85-176,326. LAWRENCE J. KONCELIK, JR., EAST HAMPTON, NY. FILED 11-14-2010.

Power Towel

THE MARK CONSISTS OF STANDARD CHARACTERS WITHOUT CLAIM TO ANY PARTICULAR FONT, STYLE, SIZE, OR COLOR.

NO CLAIM IS MADE TO THE EXCLUSIVE RIGHT TO USE "TOWEL", APART FROM THE MARK AS SHOWN.

FOR GOLF TOWELS (U.S. CLS. 42 AND 50).

KATINA MISTER, EXAMINING ATTORNEY

SN 85-194,251. SAGE MANUFACTURING CORPORATION, BAINBRIDGE ISLAND, WA. FILED 12-9-2010.

VAPORSTREAM

THE MARK CONSISTS OF STANDARD CHARACTERS WITHOUT CLAIM TO ANY PARTICULAR FONT, STYLE, SIZE, OR COLOR.

FOR FABRICS, NAMELY, TWO LAYER FABRICS HAVING AN INNER LAYER FOR WICKING MOISTURE FROM THE SKIN AND AN OUTER LAYER TO REPEL WATER AND PROVIDES INSULATION (U.S. CLS. 42 AND 50).

DEIRDRE ROBERTSON, EXAMINING ATTORNEY

CLASS 24—(Continued).

SN 85-220,195. MANUFACTURES INDUSTRIALS DE TORTELLA, S.A., TORTELLA (GIRONA), SPAIN, FILED 1-18-2011.

DERMOFRESH

THE MARK CONSISTS OF STANDARD CHARACTERS WITHOUT CLAIM TO ANY PARTICULAR FONT, STYLE, SIZE, OR COLOR.

PRIORITY CLAIMED UNDER SEC. 44(D) ON ERP N CMNTY TM OFC APPLICATION NO. 9398306, FILED 9-23-2010, REG. NO. 9398306, DATED 3-6-2011, EXPIRES 9-23-2020.

FOR BED COVERS, TEXTILE TABLE COVERS, PLASTIC TABLE COVERS, MATTRESS COVERS (U.S. CLS. 42 AND 50).

KAREN K. BUSH, EXAMINING ATTORNEY

SN 85-266,014. DIAZ, RAQUEL, SOMERSET, NY. FILED 3-14-2011.

**Shower Power Liners
Xtraordinaire**

THE MARK CONSISTS OF STANDARD CHARACTERS WITHOUT CLAIM TO ANY PARTICULAR FONT, STYLE, SIZE, OR COLOR.

NO CLAIM IS MADE TO THE EXCLUSIVE RIGHT TO USE "SHOWER" OR "LINERS", APART FROM THE MARK AS SHOWN.

FOR SHOWER CURTAIN LINERS (U.S. CLS. 42 AND 50).

TAMARA FRAZIER, EXAMINING ATTORNEY

SN 85-275,835. HOLLANDER HOME FASHIONS, LLC, BOCA RATON, FL. FILED 3-24-2011.

MEGA

THE MARK CONSISTS OF STANDARD CHARACTERS WITHOUT CLAIM TO ANY PARTICULAR FONT, STYLE, SIZE, OR COLOR.

OWNER OF U.S. REG. NO. 2,834,611.

FOR MATTRESS PADS (U.S. CLS. 42 AND 50).

KELLY BOULTON, EXAMINING ATTORNEY

CLASS 24—(Continued).

SN 85-291,258. SOTO, ROBERTO F., NEW YORK CITY, NY.
FILED 4-11-2011.

TOEL

THE MARK CONSISTS OF STANDARD CHARACTERS
WITHOUT CLAIM TO ANY PARTICULAR FONT, STYLE,
SIZE, OR COLOR.

THE WORDING TOEL HAS NO MEANING IN A FOR-
EIGN LANGUAGE.

FOR TOWELS (U.S. CLS. 42 AND 50).

MICHAEL TANNER, EXAMINING ATTORNEY

SN 85-295,740. AEOLUS DOWN, INC., CHINO, CA. FILED 4-
14-2011.

SIMPLE FIT

THE MARK CONSISTS OF STANDARD CHARACTERS
WITHOUT CLAIM TO ANY PARTICULAR FONT, STYLE,
SIZE, OR COLOR.

FOR MATTRESS PADS (U.S. CLS. 42 AND 50).

GRETTA YAO, EXAMINING ATTORNEY

SN 85-312,023. GOLDEN MILLS, LLC, CHATSWORTH, CA.
FILED 5-4-2011.

GOLDEN SPLENDOR

THE MARK CONSISTS OF STANDARD CHARACTERS
WITHOUT CLAIM TO ANY PARTICULAR FONT, STYLE,
SIZE, OR COLOR.

OWNER OF U.S. REG. NOS. 3,342,088, 3,365,067 AND
3,728,151.

FOR BED BLANKETS (U.S. CLS. 42 AND 50).

MARTHA SANTOMARTINO, EXAMINING ATTORNEY

CLASS 24—(Continued).

SN 85-313,682. MCALLISTER MILLS, INC., INDEPEN-
DENCE, VA. FILED 5-5-2011.

RICOCHET

THE MARK CONSISTS OF STANDARD CHARACTERS
WITHOUT CLAIM TO ANY PARTICULAR FONT, STYLE,
SIZE, OR COLOR.

FOR METALLIC FIBERGLASS FABRICS USED IN
COMMERCIAL HIGH HEAT APPLICATIONS IN THE
NATURE OF A MATERIAL THAT REFLECTS HEAT
(U.S. CLS. 42 AND 50).

DOMINICK J. SALEMI, EXAMINING ATTORNEY

SN 85-320,606. THE RITZ-CARLTON HOTEL COMPANY,
L.L.C., BETHESDA, MD. FILED 5-13-2011.

RITZ-CARLTON

THE MARK CONSISTS OF STANDARD CHARACTERS
WITHOUT CLAIM TO ANY PARTICULAR FONT, STYLE,
SIZE, OR COLOR.

OWNER OF U.S. REG. NO. 1,905,234.

FOR BED LINENS, TABLE LINENS, BED BLANKETS,
BED COVERS, QUILTS, DUVETS, BED SPREADS, BED
SHEETS, COMFORTERS, CLOTH NAPKINS, TOWELS,
SHOWER CURTAINS (U.S. CLS. 42 AND 50).

NAKWAMA ANKRAH, EXAMINING ATTORNEY

SN 85-343,124. KELLWOOD COMPANY, CHESTERFIELD,
MO. FILED 6-10-2011.

MY MICHELLE

THE MARK CONSISTS OF STANDARD CHARACTERS
WITHOUT CLAIM TO ANY PARTICULAR FONT, STYLE,
SIZE, OR COLOR.

OWNER OF U.S. REG. NO. 1,442,190.

FOR BED BLANKETS; BED CANOPIES; BED COVERS;
BED LINEN; BED PADS; BED SHEETS; BED SKIRTS;
BED SPREADS; BED THROWS; BLANKET THROWS;
COMFORTERS; DUVET COVERS; DUVETS; PILLOW
CASES; PILLOW SHAMS; QUILTS; SHEET SETS (U.S.
CLS. 42 AND 50).

EUGENIA MARTIN, EXAMINING ATTORNEY

CLASS 24—(Continued).

SN 85-344,644. BARILLA G. E R. FRATELLI - SOCIETÀ PER AZIONI, PARMA, ITALY, FILED 6-13-2011.

SPAGHETTATA

THE MARK CONSISTS OF STANDARD CHARACTERS WITHOUT CLAIM TO ANY PARTICULAR FONT, STYLE, SIZE, OR COLOR.

FOR TABLE CLOTHS NOT OF PAPER, CLOTH BANNERS, AND PLACE MATS NOT OF PAPER (U.S. CLS. 42 AND 50).

AISHA CLARKE, EXAMINING ATTORNEY

CLASS 25—(Continued).

SN 76-707,213. ROMANO-MCCOY, LENOR, NEW YORK, NY. FILED 4-11-2011.

MAN:U:SCRIPT BY L.ROMANO

THE MARK CONSISTS OF STANDARD CHARACTERS WITHOUT CLAIM TO ANY PARTICULAR FONT, STYLE, SIZE, OR COLOR.

OWNER OF U.S. REG. NO. 2,305,981.

THE NAME L. ROMANO IDENTIFIES A LIVING INDIVIDUAL WHOSE CONSENT IS OF RECORD.

FOR TOPS AND SWEATERS (U.S. CLS. 22 AND 39).

KAREN SEVERSON, EXAMINING ATTORNEY

SN 76-707,220. JONES, AMERICA LYNN, DAPHNE, AL. FILED 4-11-2011.

GOTTA BE BY THE WATER

THE MARK CONSISTS OF STANDARD CHARACTERS WITHOUT CLAIM TO ANY PARTICULAR FONT, STYLE, SIZE, OR COLOR.

FOR APPAREL - NAMELY, SHIRTS, CAMP SHIRTS, FISHING SHIRTS, HOODED SWEAT SHIRTS, NIGHT SHIRTS, SHORT-SLEEVED OR LONG-SLEEVED T-SHIRTS, SPORT SHIRTS, SWEAT PANTS AND SWEAT SHIRTS (U.S. CLS. 22 AND 39).

FIRST USE 11-1-2010; IN COMMERCE 11-1-2010.

WARREN L. OLANDRIA, EXAMINING ATTORNEY

SN 77-014,226. WHITELAW, JENNIFER, NAPLES, FL. FILED 10-4-2006.

ibelieve

THE MARK CONSISTS OF STANDARD CHARACTERS WITHOUT CLAIM TO ANY PARTICULAR FONT, STYLE, SIZE, OR COLOR.

FOR SPORTSWEAR, NAMELY, SHORTS, SHIRTS, T-SHIRTS, SKIRTS, TIES, BELTS FOR CLOTHING, DRESSES, PANTS, COATS, SCARVES, MITTENS, GLOVES AND SWEATERS, SUITS, JACKETS, HATS, CAPS, BOOTS, SANDALS, HEADWEAR, SHAWLS; VESTS; SLEEPWEAR; SWIMWEAR, FOOTWEAR (U.S. CLS. 22 AND 39).

JAMES MACFARLANE, EXAMINING ATTORNEY

CLASS 25—CLOTHING

SN 76-645,158. RUNWAY, NEW YORK, NY. FILED 8-18-2005.

CELEBRITY JEANS

THE MARK CONSISTS OF STANDARD CHARACTERS WITHOUT CLAIM TO ANY PARTICULAR FONT, STYLE, SIZE, OR COLOR.

NO CLAIM IS MADE TO THE EXCLUSIVE RIGHT TO USE "JEANS", APART FROM THE MARK AS SHOWN.

FOR DENIM JEANS (U.S. CLS. 22 AND 39).

FIRST USE 5-1-2005; IN COMMERCE 5-1-2005.

DANIEL CAPSHAW, EXAMINING ATTORNEY

SN 76-692,668. BALLY, JEFFREY DAVID, DBA PROVING GROUND CLOTHING CO., AND PROVING GROUND INTERNATIONAL, LAGUNA HILLS, CA. FILED 9-9-2008.

PROVING GROUND

THE MARK CONSISTS OF STANDARD CHARACTERS WITHOUT CLAIM TO ANY PARTICULAR FONT, STYLE, SIZE, OR COLOR.

FOR CLOTHING, NAMELY, HEADWEAR, T-SHIRTS AND SHORTS; AND SURF WEAR (U.S. CLS. 22 AND 39).

MARTHA FROMM, EXAMINING ATTORNEY

CLASS 25—(Continued).

SN 77-701,548. LANIER, DERRICK RENARD, LAKELAND, FL. FILED 3-28-2009.

Xcuse Me!
"Clothes Making A Statement"

THE COLOR(S) RED AND BLACK IS/ARE CLAIMED AS A FEATURE OF THE MARK.

THE MARK CONSISTS OF THE WORDING "XCUSE ME!" "CLOTHES MAKING A STATEMENT" WITH THE "X" APPEARING IN THE COLOR RED AND "CUSE ME! CLOTHES MAKING A STATEMENT" APPEARING IN THE COLOR BLACK.

FOR ATHLETIC APPAREL, NAMELY, SHIRTS, PANTS, JACKETS, FOOTWEAR, HATS AND CAPS, ATHLETIC UNIFORMS; ATHLETIC FOOTWEAR; BEACH FOOTWEAR; BELTS; BIBS NOT OF CLOTH OR PAPER; CAPS; CHILDREN'S AND INFANTS' CLOTH BIBS; CLOTH BIBS FOR USE BY SENIOR CITIZENS OR PHYSICALLY- OR MENTALLY-CHALLENGED PERSONS; CLOTH DIAPERS; CLOTHING FOR ATHLETIC USE, NAMELY, PADDED SHORTS; CLOTHING FOR WEAR IN JUDO PRACTICES; CLOTHING FOR WEAR IN WRESTLING GAMES; CLOTHING, NAMELY, ARM WARMERS; CLOTHING, NAMELY, BASE LAYERS; CLOTHING, NAMELY, FOLK COSTUMES; CLOTHING, NAMELY, HAND-WARMERS; CLOTHING, NAMELY, KHAKIS; CLOTHING, NAMELY, KNEE WARMERS; CLOTHING, NAMELY, NECK TUBES; CLOTHING, NAMELY, THOBES; CLOTHING, NAMELY, WRAP-AROUNDS; CORSETS; DUSTERS; EYESHADES; FLIP FLOPS; FOOTWEAR FOR MEN; FOOTWEAR FOR MEN AND WOMEN; FOOTWEAR FOR TRACK AND FIELD ATHLETICS; FOOTWEAR FOR WOMEN; FOOTWEAR, NAMELY, PUMPS; FOULARDS; HEADGEAR, NAMELY, HATS, CAPS, HEADBANDS; HOODS; INFANT AND TODDLER ONE PIECE CLOTHING; INFANT CLOTH DIAPERS; JAPANESE FOOTWEAR OF RICE STRAW (WARAJI); JAPANESE SPLIT-TOED WORK FOOTWEAR (JIKATABI); JERSEYS; LEATHER BELTS; MANTLES; MUFFLERS; NON-DISPOSABLE CLOTH TRAINING PANTS; PAPER HATS FOR USE AS CLOTHING ITEMS; PARTS OF CLOTHING, NAMELY, GUSSETS FOR TIGHTS, GUSSETS FOR STOCKINGS, GUSSETS FOR BATHING SUITS, GUSSETS FOR UNDERWEAR, GUSSETS FOR LEOTARDS AND GUSSETS FOR FOOTLETS; PARTS OF CLOTHING, NAMELY, UNDERARM GUSSETS; PARTY HATS; PERSPIRATION ABSORBENT UNDERWEAR CLOTHING; PUMPS; SCIENTIFIC AND TECHNOLOGICAL APPAREL, NAMELY, SHIRTS, PANTS, JACKETS, FOOTWEAR, HATS AND CAPS, UNIFORMS; SHIFTS; SHORT SETS; SHOULDER WRAPS; SOLES FOR FOOTWEAR; SWADDLING CLOTHES; THONGS; TIES; TIPS FOR FOOTWEAR; TOPS; TRAVEL CLOTHING CONTAINED IN A PACKAGE COMPRISING REVERSIBLE JACKETS, PANTS, SKIRTS, TOPS AND A BELT OR SCARF; TRIATHLON CLOTHING ; UNDERARM CLOTHING SHIELDS; WEARABLE GARMENTS AND CLOTHING, NAMELY, SHIRTS; WRAPS (U.S. CLS. 22 AND 39).

LESLIE RICHARDS, EXAMINING ATTORNEY

CLASS 25—(Continued).

SN 77-707,559. WASHBURN UNIVERSITY, TOPEKA, KS. FILED 4-6-2009.

ICHABODS

THE MARK CONSISTS OF STANDARD CHARACTERS WITHOUT CLAIM TO ANY PARTICULAR FONT, STYLE, SIZE, OR COLOR.

FOR CLOTHING, NAMELY, SWEATSHIRTS, SWEAT-PANTS, SPORT SHIRTS, NECKTIES, SHORTS, JACKETS, SWEATERS, TANK TOPS, JERSEYS, T-SHIRTS, MITTENS, SCARVES, BOXER SHORTS, SUN VISORS, SOCKS, WRISTBANDS, GLOVES, PONCHOS AND JOGGING SUITS, HATS AND CAPS, ALL FOR PROMOTING ACTIVITIES OF, SHOWING SUPPORT FOR, AND/OR SHOWING AFFILIATION WITH A UNIVERSITY, ITS STUDENTS, ALUMNI AND ATHLETIC TEAMS (U.S. CLS. 22 AND 39).

FIRST USE 0-0-2008; IN COMMERCE 0-0-2008.

NICHOLAS COLEMAN, EXAMINING ATTORNEY

SN 77-856,681. MOGAVERO, MARCELLO, ERMA, NJ. FILED 10-24-2009.

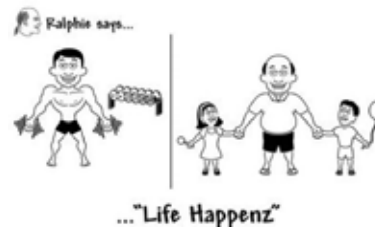

THE MARK CONSISTS OF THE PROFILE OF A MAN'S HEAD WITH A PONYTAIL TO THE LEFT OF THE WORDING "RALPHIE SAYS..." OVER THE DRAWING OF A BODYBUILDER LIFTING WEIGHTS NEXT TO A BAR HOLDING EXTRA WEIGHTS, TO THE LEFT OF A BALDING MAN HOLDING THE HAND OF A GIRL WITH A LOLLIPOP AND HOLDING THE HAND OF A BOY WITH A BALLOON, OVER THE WORDING "LIFE HAPPENZ".

FOR CLOTHING FOR ATHLETIC USE, NAMELY, PADDED SHIRTS; FISHING SHIRTS; GOLF PANTS, SHIRTS AND SKIRTS; HATS; HEADGEAR, NAMELY, HATS; HOODED SWEAT SHIRTS; LONG-SLEEVED SHIRTS; MOISTURE-WICKING SPORTS SHIRTS; NIGHT SHIRTS; OPEN-NECKED SHIRTS; PARTY HATS; POLO SHIRTS; SHIRTS; SHIRTS AND SHORT-SLEEVED SHIRTS; SHORT-SLEEVED OR LONG-SLEEVED T-SHIRTS; SHORT-SLEEVED SHIRTS; SMALL HATS; SPORT SHIRTS; SPORTS SHIRTS; SPORTS SHIRTS WITH SHORT SLEEVES; SWEAT SHIRTS; T-SHIRTS; TEE SHIRTS; TURTLE NECK SHIRTS; WEARABLE GARMENTS AND CLOTHING, NAMELY, SHIRTS (U.S. CLS. 22 AND 39).

ANN E. SAPPENFIELD, EXAMINING ATTORNEY

CLASS 25—(Continued).

SN 77-876,554. MAX AND MIGHTY GLOBAL CORPORATION, GOYANG-SI, GYEONGGI-DO, REPUBLIC OF KOREA, FILED 11-19-2009.

t.odo

THE MARK CONSISTS OF STANDARD CHARACTERS WITHOUT CLAIM TO ANY PARTICULAR FONT, STYLE, SIZE, OR COLOR.

PRIORITY CLAIMED UNDER SEC. 44(D) ON REPUBLIC OF KOREA APPLICATION NO. 2009-0034922, FILED 7-22-2009, REG. NO. 0843303, DATED 11-16-2010, EXPIRES 11-16-2020.

FOR TRAINING SHOES; SNEAKERS; RIDING BOOTS; KNEE TROUSERS; ANORAKS EXCLUDING EXERCISE WEAR; JUMPERS; BLUE JEANS; SWIMSUITS; SPORT SHIRTS; HEAD WEAR, NAMELY, CAPS; SUSPENDERS; LEATHER CLOTHING BELTS (U.S. CLS. 22 AND 39).

KIM MONINGHOFF, EXAMINING ATTORNEY

SN 77-876,987. QUIJADA, FRANCIS, LOS ANGELES, CA. FILED 11-19-2009.



THE MARK CONSISTS OF BOTTOM EYELASHES WITH THE WORD "EYELID" APPEARING ABOVE THE IMAGE IN SCRIPT FONT.

FOR CLOTHING, NAMELY, SHIRTS, T-SHIRTS, DRESSES AND SHORTS; SHOES; FOOTWEAR (U.S. CLS. 22 AND 39).

MARLENE BELL, EXAMINING ATTORNEY

SN 77-912,320. KIM, YOUNG JOON, DBA IRIS, LOS ANGELES, CA. FILED 1-14-2010.

IRIS

THE MARK CONSISTS OF STANDARD CHARACTERS WITHOUT CLAIM TO ANY PARTICULAR FONT, STYLE, SIZE, OR COLOR.

OWNER OF U.S. REG. NO. 3,443,353.

FOR BLOUSES; JEANS; KNIT SHIRTS; MEN'S AND WOMEN'S JACKETS, COATS, TROUSERS, VESTS; OVERALLS; SHIRTS; WOMEN'S TOPS, NAMELY, CAMIS (U.S. CLS. 22 AND 39).

FIRST USE 1-1-2008; IN COMMERCE 1-1-2008.

LESLIE RICHARDS, EXAMINING ATTORNEY

CLASS 25—(Continued).

SN 77-932,659. WHO DAT?, INC., NEW ORLEANS, LA. FILED 2-10-2010.

Two Dat

THE MARK CONSISTS OF STANDARD CHARACTERS WITHOUT CLAIM TO ANY PARTICULAR FONT, STYLE, SIZE, OR COLOR.

OWNER OF U.S. REG. NO. 2,890,070.

FOR CLOTHING, NAMELY, T-SHIRTS, HOODED SWEATSHIRTS, SWEATSHIRTS, BODYSUITS, CLOTH BIBS, TANK TOPS, POLO SHIRTS, HATS (U.S. CLS. 22 AND 39).

FIRST USE 2-10-2010; IN COMMERCE 2-10-2010.

ALEX KEAM, EXAMINING ATTORNEY

SN 77-947,624. PERLMAN, TERRY, VERNON, CA. FILED 3-1-2010.

VEIL

THE MARK CONSISTS OF STANDARD CHARACTERS WITHOUT CLAIM TO ANY PARTICULAR FONT, STYLE, SIZE, OR COLOR.

FOR CLOTHING, NAMELY, SHIRTS, DRESSES, SKIRTS, SHORTS, PANTS, KNIT TOPS, CAMISOLES, LEGGINGS, SCARVES, BELTS, SWEATERS, COATS, JACKETS, JEANS, SWIMSUITS, T-SHIRTS, TIGHTS, BLAZERS, TANK TOPS, UNDERGARMENTS, TOPS (U.S. CLS. 22 AND 39).

CIMMERIAN COLEMAN, EXAMINING ATTORNEY

SN 77-951,449. ZHUKOV, PAUL, TIMONIUM, MD. FILED 3-5-2010.

KILLA INSTINCT

THE MARK CONSISTS OF THE CURVING WORDS "KILLA INSTINCT" WITH A BACKWARDS "K".

FOR GYM SHORTS; HATS; HOODED SWEAT SHIRTS; LONG-SLEEVED SHIRTS; SHORT-SLEEVED SHIRTS; SHORTS; SPORTS CAPS AND HATS; SPORTS PANTS; SPORTS SHIRTS; SWEAT PANTS; SWEAT SHIRTS; T-SHIRTS; TANK TOPS; WIND PANTS (U.S. CLS. 22 AND 39).

FIRST USE 11-1-2009; IN COMMERCE 11-1-2009.

KARANENDRA S. CHHINA, EXAMINING ATTORNEY

CLASS 25—(Continued).

SN 77-963,216. CNH AMERICA, LLC, RACINE, WI. FILED 3-19-2010.

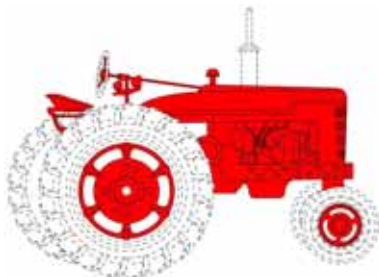

THE COLOR(S) RED, BLACK AND WHITE IS/ARE CLAIMED AS A FEATURE OF THE MARK.

THE MARK CONSISTS OF A STYLIZED DESIGN OF A TRACTOR. THE BODY AND WHEELS OF THE TRACTOR ARE RED WITH BLACK ACCENTS. THE STEERING WHEEL, TIRES AND EXHAUST PIPE ARE WHITE WITH BLACK ACCENTS.

FOR WEARING APPAREL AND CLOTHING, NAMELY, HEADWEAR, SHIRTS, COATS, JACKETS AND SWEATSHIRTS (U.S. CLS. 22 AND 39).

JESSICA FATHY, EXAMINING ATTORNEY

SN 78-346,187. DO-GREE FASHIONS LTD., QUEBEC, CANADA, FILED 12-29-2003.

CHAOS

THE MARK CONSISTS OF STANDARD CHARACTERS WITHOUT CLAIM TO ANY PARTICULAR FONT, STYLE, SIZE, OR COLOR.

OWNER OF U.S. REG. NO. 2,724,918.

FOR HEADWEAR, NAMELY, HATS AND HEADBANDS; SOCKS, SCARVES, MITTENS, GLOVES, DICKIES, SKI MASKS AND NECKTUBES, EXCLUDING MOTORCYCLE WEAR, ALL SOLD THROUGH SPORTING GOODS STORES (U.S. CLS. 22 AND 39).

FIRST USE 2-1-1997; IN COMMERCE 2-1-1997.
CURTIS FRENCH, EXAMINING ATTORNEY

CLASS 25—(Continued).

SN 79-065,089. FELINA GMBH, FED REP GERMANY, FILED 1-9-2009.

[UN: USUAL]

THE MARK CONSISTS OF STANDARD CHARACTERS WITHOUT CLAIM TO ANY PARTICULAR FONT, STYLE, SIZE, OR COLOR.

PRIORITY DATE OF 7-24-2008 IS CLAIMED.

OWNER OF INTERNATIONAL REGISTRATION 0992622 DATED 1-9-2009, EXPIRES 1-9-2019.

FOR CLOTHING, NAMELY, CORSETRY, UNDERWEAR, SWIMWEAR (U.S. CLS. 22 AND 39).
AISHA SALEM, EXAMINING ATTORNEY

SN 79-084,452. KONG LING GUO, CHINA, FILED 6-3-2010.



OWNER OF INTERNATIONAL REGISTRATION 1043666 DATED 6-3-2010, EXPIRES 6-3-2020.

THE MARK CONSISTS OF THE WORD "ENNESY" AND TWO ARCS.

FOR SWIMSUITS; BATHING CAPS; BATHING TRUNKS; BODYSUITS; BRASSIERES; SHOES (U.S. CLS. 22 AND 39).

JENNY PARK, EXAMINING ATTORNEY

SN 79-089,425. MORTELS SHEEPSKIN FACTORY PTY LTD, AUSTRALIA, FILED 9-24-2010.

Mortels

THE MARK CONSISTS OF STANDARD CHARACTERS WITHOUT CLAIM TO ANY PARTICULAR FONT, STYLE, SIZE, OR COLOR.

OWNER OF INTERNATIONAL REGISTRATION 1025781 DATED 12-17-2009, EXPIRES 12-17-2019.

FOR FOOTWEAR, CLOTHING, NAMELY, JACKETS, COATS, SHIRTS, THERMAL UNDERSHIRTS, TROUSERS, OVERALLS, SWEAT PANTS, VESTS, JUMPERS, HOODED JUMPERS, THERMAL LEGGINGS, SOCKS, T-SHIRTS, SKIRTS, SHORTS, SCARVES, NECK WARMERS, GLOVES, MITTENS, NECK AND LEG GAITERS; AND HEADWEAR, NAMELY, HATS, CAPS, BEANIES, EARMUFFS, EARBANDS AND BALACLAVAS (U.S. CLS. 22 AND 39).

CHRISTOPHER BUONGIORNO, EXAMINING ATTORNEY

CLASS 25—(Continued).

SN 79-089,623. LITTLE SHRIMP LTD., SOMERSET BA11 1NA, UNITED KINGDOM, FILED 4-30-2010.

Little Shrimp

THE MARK CONSISTS OF STANDARD CHARACTERS WITHOUT CLAIM TO ANY PARTICULAR FONT, STYLE, SIZE, OR COLOR.

OWNER OF INTERNATIONAL REGISTRATION 1057286 DATED 4-30-2010, EXPIRES 4-30-2020.

FOR CLOTHING, FOR BABIES, TODDLERS AND CHILDREN, NAMELY, DRESSES, PANTS, HATS, SHIRTS, TOPS, COATS, SKIRTS, VESTS, TROUSERS, DUNGAREES, ONE PIECE PLAY SUITS, GLOVES, BABY LAYETTES, BEACH SHOES, BOAT SHOES (U.S. CLS. 22 AND 39).

KAREN SEVERSON, EXAMINING ATTORNEY

SN 79-090,219. MIMOSKA S.R.L., ITALY, FILED 10-22-2010.

PAOLA SORMANI

THE MARK CONSISTS OF STANDARD CHARACTERS WITHOUT CLAIM TO ANY PARTICULAR FONT, STYLE, SIZE, OR COLOR.

OWNER OF INTERNATIONAL REGISTRATION 1058964 DATED 10-22-2010, EXPIRES 10-22-2020.

THE NAME(S), PORTRAIT(S), AND/OR SIGNATURE(S) SHOWN IN THE MARK DOES NOT IDENTIFY A PARTICULAR LIVING INDIVIDUAL.

FOR CLOTHING ARTICLES, NAMELY, DRESSES, OVERCOATS, RAINCOATS, JACKETS, ANORAKS, WAISTCOATS, BLOUSE JACKETS, TROUSERS, JEANS, SKIRTS, PULLOVERS, T-SHIRTS, CARDIGANS, DRESSING GOWNS, SHIRTS, BEACHWEAR, GYMNASTIC SUITS, SPORTSWEAR, NAMELY, BATHING SUITS, BEACH ROBES, PAREOS AND BERMUDA SHORTS; SWEATERS, TRACKSUITS, SHORTS; FOOTWEAR, NAMELY, SHOES, BOOTS, SANDALS, SLIPPERS; CLOTHING ACCESSORIES, NAMELY, NECKTIES, BELTS; HOSIERY, TIGHTS, STOCKINGS, GLOVES, HATS AND BERETS, SCARVES, NECKERCHIEFS AND FOULARDS (U.S. CLS. 22 AND 39).

TASNEEM HUSSAIN, EXAMINING ATTORNEY

SN 79-090,411. SOCIETE NOUVELLE MAESTRO, FRANCE, FILED 11-8-2010.

ALAIN FIGARET

Little Edition

PRIORITY DATE OF 5-31-2010 IS CLAIMED.

OWNER OF INTERNATIONAL REGISTRATION 1059690 DATED 11-8-2010, EXPIRES 11-8-2020.

OWNER OF U.S. REG. NO. 2,745,683.

NO CLAIM IS MADE TO THE EXCLUSIVE RIGHT TO USE "LITTLE EDITION", APART FROM THE MARK AS SHOWN.

THE NAME "ALAIN FIGARET" IDENTIFIES A LIVING INDIVIDUAL WHOSE CONSENT IS OF RECORD.

FOR CLOTHING FOR CHILDREN, NAMELY, BATHING SUITS, TROUSERS, BERMUDA SHORTS, SHORTS, SHIRTS, TEE-SHIRTS, POLO SHIRTS, PULLOVERS, JACKETS, SOCKS, HEADWEAR, CAPS, SCARVES (U.S. CLS. 22 AND 39).

KELLY TRUSILO, EXAMINING ATTORNEY

CLASS 25—(Continued).

SN 79-091,126. STONEFLY SPA, TREVISO, ITALY, FILED 7-5-2010.

BLUSOFT PROJECT

THE MARK CONSISTS OF STANDARD CHARACTERS WITHOUT CLAIM TO ANY PARTICULAR FONT, STYLE, SIZE, OR COLOR.

PRIORITY DATE OF 1-22-2010 IS CLAIMED.

OWNER OF INTERNATIONAL REGISTRATION 1061282 DATED 7-5-2010, EXPIRES 7-5-2020.

FOR CLOTHING, NAMELY, ATHLETIC UNIFORMS, PULLOVERS, GLOVES, CARDIGANS, JERSEYS, NECKWEAR, SWEATERS, SOCKS, STOCKINGS, TOPS, TIGHTS, TROUSERS, LEGGINGS, SKIRTS, JACKETS, JERKINS, SHIRTS, VESTS, WAISTCOATS, JUMPERS, TRACK SUITS, BLOUSES, BLOUSONS, JEANS, PANTIES, SWEAT PANTS, BERMUDA SHORTS, GYM SUITS, KNICKERS, PANTS, SHORTS, T-SHIRTS, SWEAT-SHIRTS, SUITS AND DRESSES, OVERCOATS, COATS, ANORAKS, RAINCOATS, BELTS, FOULARDS, SCARVES, LOUNGEWEAR, UNDERWEAR, BEACHWEAR, SLEEPWEAR; FOOTWEAR AND HEADGEAR, NAMELY, BERETS, HOODS, HATS, CAPS, CAPS WITH VISORS (U.S. CLS. 22 AND 39).

TRACY FLETCHER, EXAMINING ATTORNEY

SN 85-019,877. JOFIT, LLC, WARMINSTER, PA. FILED 4-21-2010.



OWNER OF U.S. REG. NO. 3,515,915.

THE MARK CONSISTS OF THE FANCIFUL REPRESENTATION OF THE NUMBER "4" AND THE WORDS "ALL BY JOFIT".

FOR MEN'S AND WOMEN'S SPORTSWEAR, NAMELY, SWEATER VESTS, CARDIGAN SWEATERS, JACKETS, SHIRTS, BERMUDA SHORTS, SKORTS, CAPRIS, PANTS, FITNESS WEAR, NAMELY, PANTS, SHORTS, CAPRIS, TOPS AND BRAS AND TENNIS WEAR, NAMELY, HALTER TOPS, SKORTS, SHIRTS AND SLEEVELESS TOPS (U.S. CLS. 22 AND 39).

KHANH LE, EXAMINING ATTORNEY

CLASS 25—(Continued).

SN 85-053,063. ELIM BIBLE INSTITUTE INC., DBA KINGDOM FORCE, LIMA, NY. FILED 6-2-2010.

Kingdom Force

THE MARK CONSISTS OF STANDARD CHARACTERS WITHOUT CLAIM TO ANY PARTICULAR FONT, STYLE, SIZE, OR COLOR.

FOR T-SHIRTS (U.S. CLS. 22 AND 39).
FIRST USE 9-1-2000; IN COMMERCE 9-1-2000.
TINA L. SNAPP, EXAMINING ATTORNEY

SN 85-056,316. MARCHELLI CORPORATION, HIALEAH, FL. FILED 6-7-2010.

Ego and Greed

THE MARK CONSISTS OF STANDARD CHARACTERS WITHOUT CLAIM TO ANY PARTICULAR FONT, STYLE, SIZE, OR COLOR.

FOR SHOES; T-SHIRTS (U.S. CLS. 22 AND 39).
FIRST USE 2-0-2002; IN COMMERCE 6-0-2008.
JANET LEE, EXAMINING ATTORNEY

SN 85-072,716. WISE, CYNTHIA, CARMEL, IN. FILED 6-28-2010.

INHERITED JEANS

THE MARK CONSISTS OF STANDARD CHARACTERS WITHOUT CLAIM TO ANY PARTICULAR FONT, STYLE, SIZE, OR COLOR.

NO CLAIM IS MADE TO THE EXCLUSIVE RIGHT TO USE "JEANS", APART FROM THE MARK AS SHOWN.

FOR INFANT WEAR; JEANS; PANTS; SHIRTS; T-SHIRTS (U.S. CLS. 22 AND 39).

GRETTA YAO, EXAMINING ATTORNEY

CLASS 25—(Continued).

SN 85-076,382. SHAHEEN, PHIL, LONG BEACH, CA. FILED 7-1-2010.

GANGSTER GOVERNMENT

THE MARK CONSISTS OF STANDARD CHARACTERS WITHOUT CLAIM TO ANY PARTICULAR FONT, STYLE, SIZE, OR COLOR.

FOR SHORT-SLEEVED OR LONG-SLEEVED T-SHIRTS (U.S. CLS. 22 AND 39).

FIRST USE 1-10-2009; IN COMMERCE 1-10-2009.
EDWARD NELSON, EXAMINING ATTORNEY

SN 85-080,314. PAUL WILLIAMS, KENT, UNITED KINGDOM, FILED 7-8-2010.



PRIORITY CLAIMED UNDER SEC. 44(D) ON ERPN CMNTY TM OFC APPLICATION NO. 009106154, FILED 5-14-2010, REG. NO. 009106154, DATED 11-2-2010, EXPIRES 5-14-2020.

OWNER OF U.S. REG. NO. 3,499,172.

THE MARK CONSISTS OF AN IMAGE OF A WORLD GLOBE WITH A MUSICAL NOTE IN THE CENTER THAT COMES OUT THE TOP OF THE WORLD GLOBE.

FOR CLOTHING, NAMELY, SWEATERS, COATS, T-SHIRTS, CAPS, SHOES (U.S. CLS. 22 AND 39).

MARK T. MULLEN, EXAMINING ATTORNEY

CLASS 25—(Continued).

SN 85-082,862. SUPER STAR INTERNATIONAL, INC., SOUTH EL MONTE, CA. FILED 7-12-2010.

 The logo for AIR SPORT features the words "AIR" and "SPORT" in a bold, sans-serif font. A four-pointed star is positioned between the two words, with its points extending towards the letters.

NO CLAIM IS MADE TO THE EXCLUSIVE RIGHT TO USE "SPORT", APART FROM THE MARK AS SHOWN. THE MARK CONSISTS OF THE WORDING "AIR SPORT" IN STYLIZED FONT AND A 4 SPOKED STAR DESIGN IS DISPOSED BETWEEN THE WORDS "AIR" AND "SPORT". FOR ATHLETIC SHOES; FOOTWEAR; RUNNING SHOES; SHOES (U.S. CLS. 22 AND 39). FIRST USE 3-1-2010; IN COMMERCE 3-1-2010. MELISSA VALLILLO, EXAMINING ATTORNEY

SN 85-100,221. CLASSMATES ONLINE, INC., SEATTLE, WA. FILED 8-4-2010.

MEMORY LANE

THE MARK CONSISTS OF STANDARD CHARACTERS WITHOUT CLAIM TO ANY PARTICULAR FONT, STYLE, SIZE, OR COLOR. OWNER OF U.S. REG. NOS. 2,996,110, 2,996,111 AND 3,330,431. FOR JACKETS, PAJAMAS, BATHROBES, FOOTWEAR AND HEAD WEAR (U.S. CLS. 22 AND 39). BRIAN CALLAGHAN, EXAMINING ATTORNEY

SN 85-100,227. CLASSMATES ONLINE, INC., SEATTLE, WA. FILED 8-4-2010.

MEMORYLANE

THE MARK CONSISTS OF STANDARD CHARACTERS WITHOUT CLAIM TO ANY PARTICULAR FONT, STYLE, SIZE, OR COLOR. OWNER OF U.S. REG. NOS. 2,996,110, 2,996,111 AND 3,330,431. FOR JACKETS, PAJAMAS, BATHROBES, FOOTWEAR AND HEAD WEAR (U.S. CLS. 22 AND 39). BRIAN CALLAGHAN, EXAMINING ATTORNEY

CLASS 25—(Continued).

SN 85-100,230. CLASSMATES ONLINE, INC., SEATTLE, WA. FILED 8-4-2010.

MEMORYLANE.COM

THE MARK CONSISTS OF STANDARD CHARACTERS WITHOUT CLAIM TO ANY PARTICULAR FONT, STYLE, SIZE, OR COLOR.

OWNER OF U.S. REG. NOS. 2,996,110, 2,996,111 AND 3,330,431.

FOR JACKETS, PAJAMAS, BATHROBES, FOOTWEAR AND HEAD WEAR (U.S. CLS. 22 AND 39). BRIAN CALLAGHAN, EXAMINING ATTORNEY

SN 85-102,268. WASHINGTON NATIONALS BASEBALL CLUB, LLC, WASHINGTON, DC. FILED 8-6-2010.

 The logo for WASHINGTON features the word "WASHINGTON" in a bold, sans-serif font. The letters are outlined and have a slight 3D effect, giving them a blocky appearance.

OWNER OF U.S. REG. NOS. 3,280,485, 3,399,436 AND OTHERS.

THE MARK CONSISTS OF THE WORD "WASHINGTON" IN STYLIZED FORM. SEC. 2(F).

FOR CLOTHING, NAMELY, HEADWEAR, JERSEYS, T-SHIRTS, SHIRTS, JACKETS, AND SWEATSHIRTS (U.S. CLS. 22 AND 39).

FIRST USE 3-0-2005; IN COMMERCE 3-0-2005. HEATHER THOMPSON, EXAMINING ATTORNEY

SN 85-112,301. KADIKI CREATIVE, LLC, WATERTOWN, MA. FILED 8-20-2010.

Life's About Change

THE MARK CONSISTS OF STANDARD CHARACTERS WITHOUT CLAIM TO ANY PARTICULAR FONT, STYLE, SIZE, OR COLOR.

FOR T-SHIRTS (U.S. CLS. 22 AND 39). BERYL GARDNER, EXAMINING ATTORNEY

CLASS 25—(Continued).

SN 85-113,912. JAKKS PACIFIC, INC., MALIBU, CA. FILED 8-23-2010.

D|COMPOSED

THE MARK CONSISTS OF STANDARD CHARACTERS WITHOUT CLAIM TO ANY PARTICULAR FONT, STYLE, SIZE, OR COLOR.

FOR HALLOWEEN, MASQUERADE, DRESS-UP, AND PLAY COSTUMES, AND COSTUME MASKS SOLD IN CONNECTION THEREWITH, HALLOWEEN, MASQUERADE, DRESS-UP AND PLAY COSTUMES AND COSTUME MASKS AND COSTUME ACCESSORIES SOLD IN CONNECTION THEREWITH SOLD AS A UNIT; PLAY COSTUMES WITH ELECTRONIC LIGHTS AND/OR SOUNDS; DRESS UP ACCESSORIES AND ROLE PLAY PROPS, NAMELY, OVERSHOES, GLOVES, HATS, BELTS, BANDANAS; HEADWEAR, FOOTWEAR, AND HOSIERY (U.S. CLS. 22 AND 39).
CIMMERIAN COLEMAN, EXAMINING ATTORNEY

CLASS 25—(Continued).

SN 85-118,285. LOVESTRENGTH LLC, SAN MARCOS, CA. FILED 8-30-2010.



THE COLOR(S) PINK AND BLACK IS/ARE CLAIMED AS A FEATURE OF THE MARK.

THE MARK CONSISTS OF THE FOLLOWING: THE WORDING "LOVESTRENGTH" IN BLACK AND A DESIGN OF A SOLID PINK ABSTRACT HEART.

FOR BELTS; BELTS FOR CLOTHING; BELTS MADE OUT OF CLOTH; BOTTOMS; BUTTON DOWN SHIRTS; DRESS SHIRTS; DUSTERS; HEADBANDS FOR CLOTHING; HOODED SWEAT SHIRTS; HOODS; JACKETS; JERSEYS; LEATHER BELTS; MUFFLERS; OPEN-NECKED SHIRTS; POLO SHIRTS; SHIRTS; SHORT SETS; SHORT-SLEEVED OR LONG-SLEEVED T-SHIRTS; SHOULDER WRAPS; SHOULDER WRAPS FOR CLOTHING; T-SHIRTS; TEE SHIRTS; TIES; TOPS; WEARABLE GARMENTS AND CLOTHING, NAMELY, SHIRTS; WRAPS (U.S. CLS. 22 AND 39).

FIRST USE 8-25-2010; IN COMMERCE 8-25-2010.
PATRICIA EVANKO, EXAMINING ATTORNEY

SN 85-120,402. EGGLETON, DORIS MARTÍNEZ, NAUCALPAN DE JUÁREZ, MEXICO, FILED 8-31-2010.

IRONWIFE

THE MARK CONSISTS OF STANDARD CHARACTERS WITHOUT CLAIM TO ANY PARTICULAR FONT, STYLE, SIZE, OR COLOR.

FOR CASUAL WEAR, SPORTS WEAR, AND PROPER ATTIRE, NAMELY, DRESS PANTS, CASUAL PANTS, DRESS SHIRTS, CASUAL SHIRTS, T-SHIRTS, SPORT PANTS, AND SWEATSHIRTS (U.S. CLS. 22 AND 39).

ALYSSA STEEL, EXAMINING ATTORNEY

SN 85-117,698. HUPEDEN & CO. (GMBH & CO.) KG, HAMBURG, FED REP GERMANY, FILED 8-27-2010.

FIRST BIKER

THE MARK CONSISTS OF STANDARD CHARACTERS WITHOUT CLAIM TO ANY PARTICULAR FONT, STYLE, SIZE, OR COLOR.

NO CLAIM IS MADE TO THE EXCLUSIVE RIGHT TO USE "BIKER", APART FROM THE MARK AS SHOWN.

FOR BICYCLING CLOTHING, NAMELY, SAFETY VESTS AND VESTS FOR USE IN ASSISTING PEOPLE IN LEARNING HOW TO RIDE A BICYCLE (U.S. CLS. 22 AND 39).

ANNE FARRELL, EXAMINING ATTORNEY

SN 85-120,477. EAMES, DANIEL, LITCHFIELD PARK, AZ. FILED 9-1-2010.

PROBABLY ILLEGAL

THE MARK CONSISTS OF STANDARD CHARACTERS WITHOUT CLAIM TO ANY PARTICULAR FONT, STYLE, SIZE, OR COLOR.

FOR CLOTHING, NAMELY, T-SHIRTS, SWEATSHIRTS, TOPS, BOTTOMS, HEADWEAR (U.S. CLS. 22 AND 39).

PAUL F. GAST, EXAMINING ATTORNEY

CLASS 25—(Continued).

SN 85-123,662. ADAM DAVID RAPP, DBA CLOTHING ARTS LTD, N. WOODMERE, NY. FILED 9-6-2010.



NO CLAIM IS MADE TO THE EXCLUSIVE RIGHT TO USE "PICK POCKET PROOF", APART FROM THE MARK AS SHOWN.

THE COLOR(S) BLACK, LIGHT GREY, MEDIUM GREY, DARK GREY, WHITE, AND PURPLE IS/ARE CLAIMED AS A FEATURE OF THE MARK.

THE MARK CONSISTS OF A LIGHT GREY CUBE WITH BLACK BORDERS AND A MEDIUM GREY DROP SHADOW WITH BLACK BORDERS WITHIN WHICH APPEARS A STYLIZED DARK GREY LETTER "P", UPWARD FACING, WITH A DARK GREY CARET AT AN ANGLE AND THE WORDING "CUBED" IN STYLIZED DARK GREY LETTERING, ABOVE WHICH APPEARS A THREE DIMENSIONAL CUBE WITH PURPLE VERTICES AND WHITE BORDERS EXTENDING PARTIALLY INWARD, BELOW WHICH APPEARS THE WORDING "PICK POCKET PROOF" IN STYLIZED BLACK LETTERING FOLLOWED BY AN ASTERISK IN BLACK.

FOR CAMOUFLAGE PANTS; CAPRI PANTS; CARGO PANTS; DRESS PANTS; HUNTING PANTS; PANTS; SHORTS; SKIRTS AND DRESSES (U.S. CLS. 22 AND 39).
FIRST USE 7-15-2009; IN COMMERCE 8-3-2010.
ERIN FALK, EXAMINING ATTORNEY

SN 85-124,775. FINNEY, JANINE, SCOTTSDALE, AZ. AND MUIRHEAD, LORY, SCOTTSDALE, AZ. FILED 9-8-2010.

THE FLIP FLOP CEO

THE MARK CONSISTS OF STANDARD CHARACTERS WITHOUT CLAIM TO ANY PARTICULAR FONT, STYLE, SIZE, OR COLOR.

NO CLAIM IS MADE TO THE EXCLUSIVE RIGHT TO USE "FLIP FLOP", APART FROM THE MARK AS SHOWN. FOR CLOTHING, NAMELY, T-SHIRTS, HOODED PULLOVERS, HOODED SWEATSHIRTS; FOOTWEAR; HEADWEAR (U.S. CLS. 22 AND 39).

ANGELA M. MICHELI, EXAMINING ATTORNEY

CLASS 25—(Continued).

SN 85-125,654. FLOOD, DENNIS M., BRENTWOOD, NY. FILED 9-9-2010.



OWNER OF U.S. REG. NO. 3,576,640.

NO CLAIM IS MADE TO THE EXCLUSIVE RIGHT TO USE "HOCKEY", APART FROM THE MARK AS SHOWN.

THE MARK CONSISTS OF THE WORDS "DMF HOCKEY" IN STYLIZED FORM, WITH A LINE UNDERLINING THE WORDING.

FOR PADDED HOCKEY PANTS (U.S. CLS. 22 AND 39).

EUGENIA MARTIN, EXAMINING ATTORNEY

SN 85-126,601. FLOOD, DENNIS M., BRENTWOOD, NY. FILED 9-10-2010.



THE COLOR(S) BLUE IS/ARE CLAIMED AS A FEATURE OF THE MARK.

THE MARK CONSISTS OF A THREE STRIPE MISCELLANEOUS DESIGN IN BLUE.

FOR PADDED HOCKEY PANTS (U.S. CLS. 22 AND 39).

EUGENIA MARTIN, EXAMINING ATTORNEY

SN 85-127,088. RILES & COMPANY, INC., ALBANY, NY. FILED 9-10-2010.

THREEPEAT

THE MARK CONSISTS OF STANDARD CHARACTERS WITHOUT CLAIM TO ANY PARTICULAR FONT, STYLE, SIZE, OR COLOR.

OWNER OF U.S. REG. NOS. 1,552,980, 1,878,690 AND 1,886,018.

SEC. 2(F).

FOR HATS; JACKETS; SHIRTS (U.S. CLS. 22 AND 39).
FIRST USE 9-20-1988; IN COMMERCE 9-20-1988.

CAROLYN CATALDO, EXAMINING ATTORNEY

CLASS 25—(Continued).

SN 85-129,271. GRAN FONDO NEW YORK INC., NEW YORK, NY. FILED 9-14-2010.

Gran Fondo New York

THE MARK CONSISTS OF STANDARD CHARACTERS WITHOUT CLAIM TO ANY PARTICULAR FONT, STYLE, SIZE, OR COLOR.

NO CLAIM IS MADE TO THE EXCLUSIVE RIGHT TO USE "NEW YORK", APART FROM THE MARK AS SHOWN.

THE ENGLISH TRANSLATION OF "GRAN FONDO" IN THE MARK IS "LONG DISTANCE RACE".

FOR COTTON AND SYNTHETIC CLOTHING, NAMELY, PANTS AND SHIRTS; GLOVES FOR BICYCLE TRAINING AND TOURING AND RACING; AND EVERYDAY WEAR, NAMELY, T-SHIRTS; BICYCLE JERSEYS; BICYCLE SHORTS; BICYCLE GLOVES; BICYCLE SOCKS; BICYCLE VEST; BICYCLE CAP (U.S. CLS. 22 AND 39).

FIRST USE 4-4-2010; IN COMMERCE 6-15-2010.
BRENDAN MCCAULEY, EXAMINING ATTORNEY

SN 85-131,518. STEVE SCHWARTZ, GREENWOOD VILLAGE, CO. FILED 9-16-2010.

GGO

THE MARK CONSISTS OF STANDARD CHARACTERS WITHOUT CLAIM TO ANY PARTICULAR FONT, STYLE, SIZE, OR COLOR.

FOR CARDIGANS; COATS; DRESSES; HATS; HOODED SWEAT SHIRTS; JACKETS; LEGGINGS; SCARVES; SHIRTS; SHORTS; SWEAT PANTS; SWEAT SHIRTS; TOPS (U.S. CLS. 22 AND 39).

FIRST USE 9-0-2009; IN COMMERCE 9-0-2009.
ANDREW RHIM, EXAMINING ATTORNEY

SN 85-138,393. ZIEHL, HEATHER R, BEL AIR, MD. AND GABINET, MELISSA D, BEL AIR, MD. FILED 9-26-2010.



THE COLOR(S) PINK, WHITE, AND BLACK IS/ARE CLAIMED AS A FEATURE OF THE MARK.

THE MARK CONSISTS OF THE WORDING "TRUE HOUSEWIVES" IN THE COLOR WHITE WITH A PINK WOMAN SITTING ON THE LETTER "S" IN THE WORD "HOUSEWIVES", ALL ON A BLACK RECTANGLE.

FOR ATHLETIC APPAREL, NAMELY, SHIRTS, PANTS, JACKETS, FOOTWEAR, HATS AND CAPS, ATHLETIC UNIFORMS; SHORT-SLEEVED OR LONG-SLEEVED T-SHIRTS; SWEAT SHIRTS; T-SHIRTS; TEE SHIRTS; WEARABLE GARMENTS AND CLOTHING, NAMELY, SHIRTS (U.S. CLS. 22 AND 39).

FIRST USE 8-31-2010; IN COMMERCE 9-25-2010.
COLLEEN DOMBROW, EXAMINING ATTORNEY

CLASS 25—(Continued).

SN 85-138,805. BABY BOY STREET COUTURE, LLC, NORTH HOLLYWOOD, CA. FILED 9-27-2010.



NO CLAIM IS MADE TO THE EXCLUSIVE RIGHT TO USE "BOY" AND "STREET COUTURE LOS ANGELES", APART FROM THE MARK AS SHOWN.

THE COLOR(S) GOLD AND BLACK IS/ARE CLAIMED AS A FEATURE OF THE MARK.

THE MARK CONSISTS OF THE STYLIZED GOLD AND BLACK WORDS "BABY BOY", ABOVE THE BLACK WORDS "STREET COUTURE" AND "LOS ANGELES".

FOR SWEATSHIRTS; T-SHIRTS (U.S. CLS. 22 AND 39).
LESLIE RICHARDS, EXAMINING ATTORNEY

SN 85-140,596. JOAS, JENELLE A, DBA URBANHALO, PRIOR LAKE, MN. FILED 9-29-2010.



NO CLAIM IS MADE TO THE EXCLUSIVE RIGHT TO USE "COUTURE", APART FROM THE MARK AS SHOWN.

THE COLOR(S) PURPLE, LAVENDER, GRAY AND BLACK IS/ARE CLAIMED AS A FEATURE OF THE MARK.

THE MARK CONSISTS OF THE WORDS "URBANHALO COMFORT COUTURE". THE NAME "URBANHALO" IS BLACK AND IS SUPERIMPOSED ON A SET OF THREE OVERLAPPING HALOS IN COLORS PURPLE, LAVENDER AND GRAY. THE PHRASE "COMFORT COUTURE" IS LOCATED BENEATH THE NAME "URBAN HALO" AND IS IN BLACK.

FOR HEADBANDS; HEADBANDS AGAINST SWEATING; HEADBANDS FOR CLOTHING (U.S. CLS. 22 AND 39).

FIRST USE 2-1-2010; IN COMMERCE 2-1-2010.
ELLEN BURNS, EXAMINING ATTORNEY

CLASS 25—(Continued).

SN 85-140,604. ST. AMBROSE UNIVERSITY, DAVENPORT, IA. FILED 9-29-2010.



THE MARK CONSISTS OF A LARGE STYLIZED "A" WITH A STYLIZED "S" INTERTWINED ON THE "A", WITH A SMALLER "T" WHICH IS CONNECTED FROM THE CROSS IN THE "T" TO THE "S".

FOR ADULT CLOTHING, NAMELY, SHIRTS, SHORTS, VESTS, HATS, SOCKS AND HOODED SWEATSHIRTS (U.S. CLS. 22 AND 39).

FIRST USE 12-31-1998; IN COMMERCE 12-31-1998.
CAROLINE WOOD, EXAMINING ATTORNEY

SN 85-143,730. TERRI MALLON, FORT MYERS, FL. FILED 10-2-2010.

HOOK WHAT

THE MARK CONSISTS OF STANDARD CHARACTERS WITHOUT CLAIM TO ANY PARTICULAR FONT, STYLE, SIZE, OR COLOR.

FOR CLOTHING, NAMELY, SHIRTS, T-SHIRTS, HATS, SWEATSHIRTS, SHORTS AND TANK TOPS (U.S. CLS. 22 AND 39).

ELLEN BURNS, EXAMINING ATTORNEY

SN 85-143,923. RIEPE, BRIAN, GUNNISON, CO. FILED 10-3-2010.

MOUNTAINFLYER

THE MARK CONSISTS OF STANDARD CHARACTERS WITHOUT CLAIM TO ANY PARTICULAR FONT, STYLE, SIZE, OR COLOR.

FOR ATHLETIC APPAREL, NAMELY, SHIRTS, PANTS, JACKETS, FOOTWEAR, HATS AND CAPS, ATHLETIC UNIFORMS (U.S. CLS. 22 AND 39).

FIRST USE 8-19-2004; IN COMMERCE 8-19-2004.
BARBARA A. GOLD, EXAMINING ATTORNEY

CLASS 25—(Continued).

SN 85-143,933. BELKIN LANA, FOREST HILLS, NY. AND LARA'OLIVAN L. ANDREA, GREENWICH, CT. FILED 10-3-2010.



NO CLAIM IS MADE TO THE EXCLUSIVE RIGHT TO USE "CHILDREN", APART FROM THE MARK AS SHOWN. THE COLOR(S) GREEN AND GRAY IS/ARE CLAIMED AS A FEATURE OF THE MARK.

THE MARK CONSISTS OF THE WORD, "DOLCEZZE" IN GREEN WITH THREE GRAY DOTS IN THE OUTER LOOP ON THE LEFT SIDE OF THE "D." ABOVE THE WORD, "CHILDREN" IN GRAY, WITH EACH LETTER SEPARATED BY A RAISED GRAY DOT.

THE ENGLISH TRANSLATION OF "DOLCEZZE" IN THE MARK IS "SWEETNESS".

FOR CHILDREN'S APPAREL, NAMELY, SKIRTS, PANTS, TOPS, DRESSES, JACKETS, SHORTS, SWEATERS, CARDIGANS, HEADBANDS, SWIMWEAR, TIGHTS, AND HATS (U.S. CLS. 22 AND 39).

BARBARA A. GOLD, EXAMINING ATTORNEY

SN 85-146,106. PAYLESS SHOESOURCE WORLDWIDE, INC., TOPEKA, KS. FILED 10-6-2010.

METAFLEX

THE MARK CONSISTS OF STANDARD CHARACTERS WITHOUT CLAIM TO ANY PARTICULAR FONT, STYLE, SIZE, OR COLOR.

FOR SHOE OUTSOLES SOLD AS AN INTEGRAL COMPONENT OF FOOTWEAR (U.S. CLS. 22 AND 39).

FIRST USE 8-0-2006; IN COMMERCE 8-0-2006.
BARBARA GAYNOR, EXAMINING ATTORNEY

SN 85-148,363. CLUB HOUSE CREATIONS, INC., NEW YORK, NY. FILED 10-8-2010.

DISCO LEMONADE

THE MARK CONSISTS OF STANDARD CHARACTERS WITHOUT CLAIM TO ANY PARTICULAR FONT, STYLE, SIZE, OR COLOR.

FOR CHILDRENS WEARING APPAREL, NAMELY, PANTS, JACKETS, SHIRTS, VESTS, COATS, SHORTS, CAPES, DRESSES, SKIRTS, BLOUSES, AND SHOES (U.S. CLS. 22 AND 39).

JANICE KIM, EXAMINING ATTORNEY

CLASS 25—(Continued).

SN 85-148,371. CLUB HOUSE CREATIONS, INC., NEW YORK, NY. FILED 10-8-2010.

RUSTIC SOULS

THE MARK CONSISTS OF STANDARD CHARACTERS WITHOUT CLAIM TO ANY PARTICULAR FONT, STYLE, SIZE, OR COLOR.

FOR MENS AND BOYS WEARING APPAREL, NAMELY, SUITS, PANTS, JACKETS, SHIRTS, VESTS, COATS, SHORTS AND SWEATERS (U.S. CLS. 22 AND 39).

JANICE KIM, EXAMINING ATTORNEY

SN 85-151,000. RADVANY, THOMAS, BROOKLYN, NY. FILED 10-12-2010.

IMMIGRANTS NEVER SURRENDER

THE MARK CONSISTS OF STANDARD CHARACTERS WITHOUT CLAIM TO ANY PARTICULAR FONT, STYLE, SIZE, OR COLOR.

FOR BASEBALL CAPS AND HATS; BELTS; BERMUDA SHORTS; BOXER SHORTS; CAMOUFLAGE PANTS; CAPRI PANTS; CARGO PANTS; DENIMS; DRESS PANTS; GLOVES AS CLOTHING; GOLF SHORTS; GYM PANTS; GYM SHORTS; HATS; HEADBANDS FOR CLOTHING; HUNTING PANTS; JACKETS; JEANS; JEGGINGS, NAMELY, PANTS THAT ARE PARTIALLY JEANS AND PARTIALLY LEGGINGS; JERSEYS; JOGGING PANTS; PANTS; SHIRTS; SHIRTS AND SHORT-SLEEVED SHIRTS; SHORT-SLEEVED OR LONG-SLEEVED T-SHIRTS; SHORTS; SNOW PANTS; SNOWBOARD PANTS; SPORTS PANTS; SWEAT PANTS; T-SHIRTS; TIES; TOPS; TRACK PANTS; WEARABLE GARMENTS AND CLOTHING, NAMELY, SHIRTS; WIND PANTS; YOGA PANTS (U.S. CLS. 22 AND 39).

COLLEEN DOMBROW, EXAMINING ATTORNEY

SN 85-151,806. YAMA SHARIFI, INDIANAPOLIS, IN. FILED 10-13-2010.

ANI

THE MARK CONSISTS OF STANDARD CHARACTERS WITHOUT CLAIM TO ANY PARTICULAR FONT, STYLE, SIZE, OR COLOR.

FOR FOOTWEAR (U.S. CLS. 22 AND 39).

FIRST USE 8-12-2010; IN COMMERCE 8-12-2010.

CHRISTINA SOBRAL, EXAMINING ATTORNEY

CLASS 25—(Continued).

SN 85-152,116. PROVO, INC., DBA RVR NECKWEAR, NEW YORK, NY. FILED 10-13-2010.

RVR

THE MARK CONSISTS OF A STYLIZED BACKWARDS LETTER "R", A STYLIZED LETTER "V", AND A STYLIZED BACKWARDS "R".

FOR TIES, POCKET SQUARES, BELTS (U.S. CLS. 22 AND 39).

JANICE L. MCMORROW, EXAMINING ATTORNEY

SN 85-161,983. MARY FAGNANO, AKA THINK KIND, LOS ANGELES, CA. FILED 10-27-2010.



THE COLOR(S) TURQUOISE IS/ARE CLAIMED AS A FEATURE OF THE MARK.

THE MARK CONSISTS OF A DESIGN OF A CIRCLE WITH BURSTS AROUND THE OUTSIDE, THE PHRASE "THINK KIND" IN CUT OUT LETTER DESIGN PLACED IN A CIRCULAR PATTERN WITH THE WORD "THINK" AT THE TOP AND "KIND" IN THE LOWER HALF OF THE CIRCLE AND A SMALLER CIRCLE IN THE CENTER WITH AN IMAGE REPRESENTING A LOTUS FLOWER. THE MARK IS IN TURQUOISE FOR USE ON ANY COLOR BACKGROUND.

FOR MENS AND WOMENS CLOTHING, NAMELY, T-SHIRTS, SWEATSHIRTS, SWEAT PANTS, SHORTS, SCARVES, TIES, HATS (U.S. CLS. 22 AND 39).

CHRIS WELLS, EXAMINING ATTORNEY

CLASS 25—(Continued).

SN 85-165,746. NIEMELAE, MARKUS SAMULI, RAUMA, FINLAND, FILED 10-31-2010.

lost reality

THE MARK CONSISTS OF STANDARD CHARACTERS WITHOUT CLAIM TO ANY PARTICULAR FONT, STYLE, SIZE, OR COLOR.

OWNER OF FINLAND REG. NO. 247882, DATED 12-31-2009, EXPIRES 12-31-2019.

FOR ATHLETIC APPAREL, NAMELY, SHIRTS, PANTS, JACKETS, FOOTWEAR, HATS AND CAPS, ATHLETIC UNIFORMS (U.S. CLS. 22 AND 39).
TAMARA FRAZIER, EXAMINING ATTORNEY

SN 85-176,380. VOICES OF HUMANITY, MEMPHIS, TN. FILED 11-15-2010.

VOICES OF HUMANITY

THE MARK CONSISTS OF STANDARD CHARACTERS WITHOUT CLAIM TO ANY PARTICULAR FONT, STYLE, SIZE, OR COLOR.

FOR CLOTHING, NAMELY, TOPS, BOTTOMS, TEE SHIRTS, HOODED SWEATSHIRTS, HATS, LOUNGE WEAR, SLEEP WEAR, SWEATSHIRTS, SHORTS, SKIRTS, PANTS, DRESSES, JACKETS, CAPS, FOOTWEAR, SOCKS, BANDANAS, BEACHWEAR, COATS, NECKWEAR, AND UNDERGARMENTS (U.S. CLS. 22 AND 39).
COLLEEN DOMBROW, EXAMINING ATTORNEY

SN 85-184,867. DAN FENELON, MADISON, NJ. AND WILLIAM GLYNN, NEW YORK, NY. FILED 11-24-2010.



NO CLAIM IS MADE TO THE EXCLUSIVE RIGHT TO USE "LAX", APART FROM THE MARK AS SHOWN.

THE COLOR(S) WHITE AND BLACK IS/ARE CLAIMED AS A FEATURE OF THE MARK.

THE MARK CONSISTS OF THE WORDING "WAVEDOG LAX". THE WORDS "WAVEDOG" AND "LAX" ARE IN WHITE AND SUPERIMPOSED OVER A BLACK RECTANGLE.

FOR CLOTHING, NAMELY, T-SHIRTS, TANK-TOPS, HOODED SWEATSHIRTS, SHORTS, CAPS AND SOCKS (U.S. CLS. 22 AND 39).

FIRST USE 9-25-2010; IN COMMERCE 9-25-2010.
ELLEN BURNS, EXAMINING ATTORNEY

CLASS 25—(Continued).

SN 85-185,352. DEREK LAIDLAW., STONEY CREEK, CANADA, AND ALISON LAIDLAW., STONEY CREEK, CANADA, AND MICHELLE LAIDLAW., STONEY CREEK, CANADA, AND JESSICA KEYTE, STONEY CREEK, CANADA, FILED 11-25-2010.

chicked, chick'd

THE MARK CONSISTS OF STANDARD CHARACTERS WITHOUT CLAIM TO ANY PARTICULAR FONT, STYLE, SIZE, OR COLOR.

PRIORITY CLAIMED UNDER SEC. 44(D) ON CANADA APPLICATION NO. 1493309, FILED 9-3-2010.

FOR ATHLETIC APPAREL, NAMELY, SHIRTS, PANTS, JACKETS, FOOTWEAR, HATS AND CAPS, ATHLETIC UNIFORMS (U.S. CLS. 22 AND 39).
KELLEY WELLS, EXAMINING ATTORNEY

SN 85-185,382. HADDAD, DIANA M., NORTH HOLLYWOOD, CA. FILED 11-26-2010.

NANI BITAR

THE MARK CONSISTS OF STANDARD CHARACTERS WITHOUT CLAIM TO ANY PARTICULAR FONT, STYLE, SIZE, OR COLOR.

THE NAME(S), PORTRAIT(S), AND/OR SIGNATURE(S) SHOWN IN THE MARK DOES NOT IDENTIFY A PARTICULAR LIVING INDIVIDUAL.

THE WORDING "NANI BITAR" HAS NO MEANING IN A FOREIGN LANGUAGE.

FOR CLOTHING, NAMELY, DRESSES, TOPS, BLAZERS, SCARVES (U.S. CLS. 22 AND 39).
ELIZABETH KAJUBI, EXAMINING ATTORNEY

CLASS 25—(Continued).

SN 85-186,283. JOY MARK INC, NEW YORK, NY. FILED 11-29-2010.

Jennifer Eden

THE MARK CONSISTS OF STANDARD CHARACTERS WITHOUT CLAIM TO ANY PARTICULAR FONT, STYLE, SIZE, OR COLOR.

THE NAME(S), PORTRAIT(S), AND/OR SIGNATURE(S) SHOWN IN THE MARK DOES NOT IDENTIFY A PARTICULAR LIVING INDIVIDUAL.

FOR APPAREL FOR DANCERS, NAMELY, TEE SHIRTS, SWEATSHIRTS, PANTS, LEGGINGS, SHORTS AND JACKETS; ATHLETIC APPAREL, NAMELY, SHIRTS, PANTS, JACKETS, FOOTWEAR, HATS AND CAPS, ATHLETIC UNIFORMS; KNIT BOTTOMS; KNIT DRESSES; KNIT JACKETS; KNIT SHIRTS; KNIT SKIRTS; WOVEN BOTTOMS; WOVEN DRESSES; WOVEN OR KNITTED UNDERWEAR; WOVEN SKIRTS; WOVEN TOPS (U.S. CLS. 22 AND 39).

FIRST USE 4-27-1989; IN COMMERCE 4-27-1989.
STEVEN JACKSON, EXAMINING ATTORNEY

SN 85-190,899. BLUE HERON ENTERTAINMENT, INC., WESTBURY, NY. FILED 12-5-2010.

PEACE People Embracing All Cultures Equally

THE MARK CONSISTS OF STANDARD CHARACTERS WITHOUT CLAIM TO ANY PARTICULAR FONT, STYLE, SIZE, OR COLOR.

FOR SHORT-SLEEVED OR LONG-SLEEVED T-SHIRTS (U.S. CLS. 22 AND 39).

FIRST USE 11-21-2010; IN COMMERCE 11-29-2010.
SARA BENJAMIN, EXAMINING ATTORNEY

CLASS 25—(Continued).

SN 85-201,140. ALIGN TECHNOLOGY SOLUTIONS, LLC, ARLINGTON, VA. FILED 12-17-2010.

T-BLAZER

THE MARK CONSISTS OF STANDARD CHARACTERS WITHOUT CLAIM TO ANY PARTICULAR FONT, STYLE, SIZE, OR COLOR.

FOR CUSTOM MADE TO MEASURE SUITS FOR MEN AND WOMEN; DRESS SUITS; FISHERMEN'S JACKETS; FUR COATS AND JACKETS; FUR JACKETS; HEAVY JACKETS; JACKETS; LADIES' SUITS; LEATHER JACKETS; LEISURE SUITS; MEN'S AND WOMEN'S JACKETS, COATS, TROUSERS, VESTS; MEN'S SUITS; MEN'S SUITS, WOMEN'S SUITS; OUTER JACKETS; PADDED JACKETS; SHELL JACKETS; SHIRTS FOR SUITS; SLEEVED OR SLEEVELESS JACKETS; SMOKING JACKETS; SNOWBOARD JACKETS; SPORTS JACKETS; SUEDE JACKETS; SUIT COATS; SUITS; SUITS OF LEATHER; SWEAT JACKETS (U.S. CLS. 22 AND 39).

JOHN WILKE, EXAMINING ATTORNEY

SN 85-202,663. WORLD WRESTLING ENTERTAINMENT, INC., STAMFORD, CT. FILED 12-21-2010.

SMACKDOWN

THE MARK CONSISTS OF STANDARD CHARACTERS WITHOUT CLAIM TO ANY PARTICULAR FONT, STYLE, SIZE, OR COLOR.

OWNER OF U.S. REG. NO. 2,941,520.

FOR CLOTHING, NAMELY, TOPS, JACKETS, BOTTOMS, UNDERWEAR, PAJAMAS; FOOTWEAR, NAMELY, SHOES, SNEAKERS, SLIPPERS; HEADWEAR, NAMELY, HATS (U.S. CLS. 22 AND 39).

FIRST USE 5-1-2002; IN COMMERCE 5-1-2002.
DANNEAN HETZEL, EXAMINING ATTORNEY

SN 85-202,739. WORLD WRESTLING ENTERTAINMENT, INC., STAMFORD, CT. FILED 12-21-2010.

SUMMERSLAM

THE MARK CONSISTS OF STANDARD CHARACTERS WITHOUT CLAIM TO ANY PARTICULAR FONT, STYLE, SIZE, OR COLOR.

OWNER OF U.S. REG. NOS. 1,571,823, 1,884,646 AND 2,702,648.

FOR CLOTHING, NAMELY, TOPS, JACKETS, BOTTOMS, UNDERWEAR, PAJAMAS; FOOTWEAR, NAMELY, SHOES, SNEAKERS, SLIPPERS; HEADWEAR, NAMELY, HATS (U.S. CLS. 22 AND 39).

FIRST USE 7-29-1988; IN COMMERCE 7-29-1988.
DANNEAN HETZEL, EXAMINING ATTORNEY

CLASS 25—(Continued).

SN 85-205,394. WILLIAM MICHAEL PAYNE, AKA CLIP PAYNE, WOODSTOCK, NY. FILED S.R. 12-23-2010; AM. P.R. 6-22-2011.

DRUGS

THE MARK CONSISTS OF STANDARD CHARACTERS WITHOUT CLAIM TO ANY PARTICULAR FONT, STYLE, SIZE, OR COLOR.

OWNER OF U.S. REG. NO. 3,249,431.

FOR APPAREL FOR DANCERS, NAMELY, TEE SHIRTS, SWEATSHIRTS, PANTS, LEGGINGS, SHORTS AND JACKETS; ATHLETIC APPAREL, NAMELY, SHIRTS, PANTS, JACKETS, FOOTWEAR, HATS AND CAPS, ATHLETIC UNIFORMS; BASEBALL CAPS AND HATS; JEANS; JEGGINGS, NAMELY, PANTS THAT ARE PARTIALLY JEANS AND PARTIALLY LEGGINGS (U.S. CLS. 22 AND 39).

FIRST USE 4-20-2000; IN COMMERCE 4-20-2000.
JENNIFER DIXON, EXAMINING ATTORNEY

SN 85-205,648. HUANG, QIAORAN, NEW YORK, NY. FILED 12-25-2010.

BABYGHOST

THE MARK CONSISTS OF STANDARD CHARACTERS WITHOUT CLAIM TO ANY PARTICULAR FONT, STYLE, SIZE, OR COLOR.

FOR APPAREL FOR DANCERS, NAMELY, TEE SHIRTS, SWEATSHIRTS, PANTS, LEGGINGS, SHORTS AND JACKETS; ATHLETIC APPAREL, NAMELY, SHIRTS, PANTS, JACKETS, FOOTWEAR, HATS AND CAPS, ATHLETIC UNIFORMS; BALLOON PANTS; BASEBALL CAPS AND HATS; BOMBER JACKETS; BOXER SHORTS; BOXING SHORTS; CAMOUFLAGE PANTS; DENIM JACKETS; DENIMS; DOWN JACKETS; DRESS PANTS; DRESS SHIELDS; DRESS SHIRTS; DRESS SUITS; DRESSES; FOOTWEAR FOR MEN AND WOMEN; FUR COATS AND JACKETS; FUR HATS; FUR JACKETS; GYM PANTS; HATS; KNIT DRESSES; KNIT JACKETS; LEATHER JACKETS; LEATHER PANTS; LEGGINGS; LEOTARDS AND TIGHTS FOR WOMEN, MEN AND CHILDREN OF NYLON, COTTON OR OTHER TEXTILE FIBERS; LIGHT-REFLECTING JACKETS; LONG JACKETS; MEN'S AND WOMEN'S JACKETS, COATS, TROUSERS, VESTS; MEN'S SUITS, WOMEN'S SUITS; PANTIES, SHORTS AND BRIEFS; RAINPROOF JACKETS; REVERSIBLE JACKETS; SCARFS; SHELL JACKETS; SHIRTS AND SHORT-SLEEVED SHIRTS; SHORT TROUSERS; SHORT-SLEEVED OR LONG-SLEEVED T-SHIRTS; SHORTS; SKIRT SUITS; SKIRTS; SKIRTS AND DRESSES; SLEEP PANTS; SPORTS PANTS; STRETCH PANTS; SWEAT JACKETS; SWEAT PANTS; SWEAT SHORTS; T-SHIRTS; TANK TOPS; TANK-TOPS; TROUSERS OF LEATHER; UNDERWEAR, NAMELY, BOY SHORTS; WOMEN'S HATS AND HOODS; WOMEN'S SHOES; WOMEN'S TOPS, NAMELY, CAMIS; WOMEN'S UNDERWEAR; WOVEN DRESSES; WOVEN SKIRTS (U.S. CLS. 22 AND 39).

MARK PILARO, EXAMINING ATTORNEY

CLASS 25—(Continued).

SN 85-211,980. ACOSTA MILLAN, KILLEEN, TX. FILED 1-6-2011.

Acosta Millan

THE MARK CONSISTS OF STANDARD CHARACTERS WITHOUT CLAIM TO ANY PARTICULAR FONT, STYLE, SIZE, OR COLOR.

THE NAME(S), PORTRAIT(S), AND/OR SIGNATURE(S) SHOWN IN THE MARK DOES NOT IDENTIFY A PARTICULAR LIVING INDIVIDUAL.

FOR BELTS; FOOTWEAR; SHOES; TIES (U.S. CLS. 22 AND 39).

JOHN KELLY, EXAMINING ATTORNEY

SN 85-218,667. KARMASU TECHNOLOGY INC., VANCOUVER, CANADA, FILED 1-15-2011.

BOMBAY BAGS

THE MARK CONSISTS OF STANDARD CHARACTERS WITHOUT CLAIM TO ANY PARTICULAR FONT, STYLE, SIZE, OR COLOR.

OWNER OF CANADA REG. NO. TMA797,434, DATED 5-12-2011, EXPIRES 5-12-2026.

FOR DRESSES; JACKETS; PANTS; SCARVES; SHIRTS; SHORTS; SKIRTS; SWEATPANTS; SWEATSHIRTS; T-SHIRTS (U.S. CLS. 22 AND 39).

LINDA M. KING, EXAMINING ATTORNEY

SN 85-235,041. CRISTEA, ROBERT O., DBA CRISTEA ENTERPRISES LLC, ANDOVER, NJ. FILED 2-5-2011.



THE COLOR(S) BLUE AND SILVER IS/ARE CLAIMED AS A FEATURE OF THE MARK.

THE COLOR SILVER APPEARS IN THE DESIGN OF A FOOTPRINT. THE COLOR BLUE APPEARS IN THE DEPICTION OF AN OCEAN WAVE.

FOR FLIP FLOPS (U.S. CLS. 22 AND 39).

EVELYN BRADLEY, EXAMINING ATTORNEY

CLASS 25—(Continued).

SN 85-235,122. CATURIA, KADE, DBA CONSTRUCTION LINES, BUFFALO, WY. AND PETERSON, DANIEL L., DBA CONSTRUCTION LINES, BUFFALO, WY. FILED 2-6-2011.

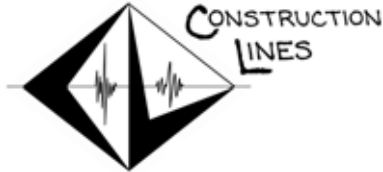

NO CLAIM IS MADE TO THE EXCLUSIVE RIGHT TO USE "CONSTRUCTION LINES", APART FROM THE MARK AS SHOWN.

THE MARK CONSISTS OF AN OVERALL DIAMOND SHAPE, A STYLIZED LETTER "C" AND "L", AND A HORIZONTAL LINE RUNNING THROUGH THE CENTER OF THE DIAMOND WITH TWO SOUND WAVES WITHIN THE DIAMOND, AND THE WORDS "CONSTRUCTION LINES".

FOR CARGO PANTS; HATS; SWEATSHIRTS; T-SHIRTS (U.S. CLS. 22 AND 39).

WARREN L. OLANDRIA, EXAMINING ATTORNEY

CLASS 25—(Continued).

SN 85-241,112. HONG, FAN, TAIPEI CITY, TAIWAN, FILED 2-13-2011.



THE MARK CONSISTS OF FOUR ENGLISH LETTERS AND ONE CHINESE CHARACTER. STARTING FROM LEFT TO RIGHT, THE ENGLISH LETTERS ARE "DAZI" IN CAPITAL FORM. THE CHINESE CALLIGRAPHY CHARACTER IS PLACED NEXT TO THE ENGLISH LETTER "I" ON THE RIGHT-HAND SIDE OF THE MARK, AND IT IS PRONOUNCED "ZHAI" IN MANDARIN.

THE ENGLISH TRANSLATION OF THE CHINESE CHARACTER (ZHAI) IN THE MARK IS VILLAGE.

THE NON-LATIN CHARACTERS IN THE MARK TRANSLITERATE TO "ZHAI".

FOR ATHLETIC APPAREL, NAMELY, SHIRTS, PANTS, JACKETS, FOOTWEAR, HATS AND CAPS, ATHLETIC UNIFORMS (U.S. CLS. 22 AND 39).

FIRST USE 1-17-2011, THE MARK WAS FIRST USED ANYWHERE IN A DIFFERENT FORM OTHER THAN THAT SOUGHT TO BE REGISTERED AT LEAST AS EARLY AS 01/17/2011; IN COMMERCE 1-17-2011, THE MARK WAS FIRST USED IN COMMERCE IN A DIFFERENT FORM OTHER THAN THAT SOUGHT TO BE REGISTERED AT LEAST AS EARLY AS 01/17/2011.

MICHAEL ENGEL, EXAMINING ATTORNEY

SN 85-242,697. MCKINLEY, JAIME, AMSTON, CT. FILED 2-15-2011.



OUT-OF-THIS-WORLD COMFORT,
WITH COSMIC BENEFITS!

THE MARK CONSISTS OF STANDARD CHARACTERS WITHOUT CLAIM TO ANY PARTICULAR FONT, STYLE, SIZE, OR COLOR.

FOR CLOTHING, NAMELY, UNDERWEAR, T-SHIRTS, SHIRTS, BLOUSES, PANTS, SHORTS, SOCKS, LEGGINGS, STOCKINGS, TIGHTS, AND BELTS; HEADWEAR, NAMELY, CAPS, HATS, VISORS, HOODED T-SHIRTS AND HOODED SWEATSHIRTS; AND FOOTWEAR (U.S. CLS. 22 AND 39).

NAPOLEON SHARMA, EXAMINING ATTORNEY

THE COLOR(S) BLACK, WHITE, BLUE AND ORANGE IS/ ARE CLAIMED AS A FEATURE OF THE MARK.

THE MARK CONSISTS OF A TORSO SILHOUETTE WITH THE WORDING "FIT" IN WHITE WITH A BLUE DOT OVER THE LETTER "I", "TO" IN ORANGE, AND "FLATTER" IN WHITE LOWER CASE LETTERS, ALL OVERLAPPING AND PLACED WITHIN THE CENTRAL PORTION OF THE SILHOUETTE.

FOR CLOTHING, NAMELY, SHIRTS, CAMISOLES AND UNDERGARMENTS (U.S. CLS. 22 AND 39).

ESTHER A. BORSUK, EXAMINING ATTORNEY

CLASS 25—(Continued).

SN 85-242,845. MOACTIM LIMITED, DUBAI, UNITED ARAB EMIR., FILED 2-15-2011.



THE MARK CONSISTS OF THE SILHOUETTE OF A DUCK PLACED INSIDE A CIRCLE AND THE WORDING "BLING DUCK" GOING AROUND THE CIRCLE AND IN A RECTANGLE UNDERNEATH THE CIRCLE FOR FOOTWEAR (U.S. CLS. 22 AND 39).
LESLIE RICHARDS, EXAMINING ATTORNEY

SN 85-249,065. BLOTZER, ROBERT, CASTAIC, CA. FILED 2-23-2011.

RATT N ROLL

THE MARK CONSISTS OF STANDARD CHARACTERS WITHOUT CLAIM TO ANY PARTICULAR FONT, STYLE, SIZE, OR COLOR.
FOR CLOTHING, NAMELY, T-SHIRTS, TANK TOPS, LONG SLEEVE SHIRTS, HOODED SWEATSHIRTS, UNDERWEAR, HATS, JACKETS, COATS, WRIST BANDS, SWEAT BANDS, PANTS, SHORTS, FOOTWEAR (U.S. CLS. 22 AND 39).
ROBERT C. CLARK JR., EXAMINING ATTORNEY

SN 85-252,203. DIVING EQUIPMENT AND MARKETING ASSOCIATION, SAN DIEGO, CA. FILED 2-25-2011.

DiveCaching

THE MARK CONSISTS OF STANDARD CHARACTERS WITHOUT CLAIM TO ANY PARTICULAR FONT, STYLE, SIZE, OR COLOR.
FOR CLOTHING, NAMELY, SHIRTS, SWEATSHIRTS, AND HATS (U.S. CLS. 22 AND 39).
CHARISMA HAMPTON, EXAMINING ATTORNEY

CLASS 25—(Continued).

SN 85-252,566. FRANDRUP, ERIN L, DBA FRANKENSWEATER, WAUPACA, WI. FILED 2-26-2011.

Frankensweater

THE MARK CONSISTS OF STANDARD CHARACTERS WITHOUT CLAIM TO ANY PARTICULAR FONT, STYLE, SIZE, OR COLOR.
FOR COATS; JACKETS; OUTER JACKETS; SWEATERS (U.S. CLS. 22 AND 39).
FIRST USE 7-28-2010; IN COMMERCE 7-28-2010.
PRISCILLA MILTON, EXAMINING ATTORNEY

SN 85-253,620. KATY POP INC., NEW YORK, NY. FILED 2-28-2011.

LADY KATIE

THE MARK CONSISTS OF STANDARD CHARACTERS WITHOUT CLAIM TO ANY PARTICULAR FONT, STYLE, SIZE, OR COLOR.
THE NAME "LADY KATIE" DOES NOT IDENTIFY A LIVING INDIVIDUAL.
FOR WEARING APPAREL, NAMELY, MEN'S, WOMEN'S AND CHILDREN'S JEANS, T-SHIRTS, SHORTS, SWEAT PANTS, SWEAT SHIRTS, UNDERWEAR, SOCKS; FOOTWEAR (U.S. CLS. 22 AND 39).
RUDY R. SINGLETON, EXAMINING ATTORNEY

SN 85-254,123. LE MIGNOT, SUZANNE, CHICAGO, IL. FILED S.R. 3-1-2011; AM. P.R. 7-18-2011.

Mess free in 1, 2, 3!

THE MARK CONSISTS OF STANDARD CHARACTERS WITHOUT CLAIM TO ANY PARTICULAR FONT, STYLE, SIZE, OR COLOR.
FOR BABY BIBS NOT OF PAPER; CHILDREN'S AND INFANT'S APPAREL, NAMELY, JUMPERS, OVERALL SLEEPWEAR, PAJAMAS, ROMPERS AND ONE-PIECE GARMENTS; CHILDREN'S AND INFANTS' APPAREL TREATED WITH FIRE AND HEAT RETARDANTS, NAMELY, JUMPERS, OVERALL SLEEPWEAR, PAJAMAS, ROMPERS AND ONE-PIECE GARMENTS; CLOTHING FOR BABIES, TODDLERS AND CHILDREN, TREATED WITH FIRE AND HEAT RETARDANTS, NAMELY, PAJAMAS, JACKETS, SHIRTS, PANTS, JUMPERS; PLASTIC BABY BIBS (U.S. CLS. 22 AND 39).
FIRST USE 3-15-2010; IN COMMERCE 5-15-2010.
KEVIN CORWIN, EXAMINING ATTORNEY

CLASS 25—(Continued).

SN 85-257,340. JIMENEZ, RICHARD E., BRONX, NY. FILED 3-3-2011.



THE MARK CONSISTS OF THE STYLIZED WORDING "KATZ'EN" IN WHICH THE LETTER "A" IS UPSIDE DOWN, FOLLOWED BY A CIRCULAR DOT AND THE STYLIZED WORDING "JAMMER". UNDERNEATH OF THE WORDING "JAMMER" IS THE TERM "24/7" APPEARING INSIDE BRACKETS. UNDERNEATH OF THE AFOREMENTIONED STYLIZED WORDING IS A DESIGN OF A BALD CARTOON HEAD WITH TWO X'S REPRESENTING THE EYES, A SINGLE WATER DROP APPEARING ON THE TEMPLE AND THE LETTERS "K" AND "J" APPEARING ON THE LEFT AND RIGHT EARS, RESPECTIVELY.

FOR BANDANAS; BELTS; BLOUSES; HATS; HOODED SWEAT SHIRTS; JACKETS; JEANS; PANTS; POLO SHIRTS; SHIRTS; SHORTS; SOCKS; SWEATERS; T-SHIRTS; TANK TOPS; UNDERWEAR; VISORS (U.S. CLS. 22 AND 39).

HAI-LY LAM, EXAMINING ATTORNEY

CLASS 25—(Continued).

SN 85-259,263. BASLEY, IMANUEL C, CHICAGO, IL. FILED 3-6-2011.



NO CLAIM IS MADE TO THE EXCLUSIVE RIGHT TO USE "CLOTHING CO.", APART FROM THE MARK AS SHOWN.

THE MARK CONSISTS OF A CHECKERED SHIELD ENCOMPASSED BY A LAUREL WREATH, ON THE DARK SQUARES INSIDE THE SHIELD ARE THE INITIALS "U" AND "P" BOTH IN OPPOSITE SQUARES; IN THE UPPER LIGHT SQUARE ARE THREE PIGEONS WITH ONE OF THEM EATING; IN THE BOTTOM LIGHT SQUARE ARE TWO HANDS SHAKING OVER A BOOK OF KNOWLEDGE; OVER THE TOP OF THE SHIELD IS A CROWN AND BENEATH IT IS A RIBBON SCROLL CONTAINING THE WORDS "URBAN PREP CLOTHING CO.".

FOR ATHLETIC APPAREL, NAMELY, SHIRTS, PANTS, JACKETS, FOOTWEAR, HATS AND CAPS, ATHLETIC UNIFORMS; HOODED SWEATSHIRTS; SHORT-SLEEVED OR LONG-SLEEVED T-SHIRTS; SWEATSHIRTS; T-SHIRTS; TOBOGGAN HATS, PANTS AND CAPS (U.S. CLS. 22 AND 39).

FIRST USE 9-16-2010; IN COMMERCE 11-22-2010.

TOBY BULLOFF, EXAMINING ATTORNEY

SN 85-259,450. JOE'S JEANS SUBSIDIARY, INC., COMMERCE, CA. FILED 3-7-2011.

JOE'S WILD

THE MARK CONSISTS OF STANDARD CHARACTERS WITHOUT CLAIM TO ANY PARTICULAR FONT, STYLE, SIZE, OR COLOR.

OWNER OF U.S. REG. NOS. 3,156,022, 3,861,398 AND OTHERS.

FOR CLOTHING, NAMELY, SHIRTS, LONG-SLEEVED SHIRTS, T-SHIRTS, UNDER SHIRTS, NIGHT SHIRTS, RUGBY SHIRTS, POLO SHIRTS, CARDIGANS, JERSEYS, UNIFORMS, SCRUBS NOT FOR MEDICAL PURPOSES, SMOCKS, DRESS SHIRTS, BOTTOMS, PANTS, JEANS, CULOTTES, CARGO PANTS, STRETCH PANTS, DENIM JEANS, OVERALLS, COVERALLS, JUMPERS, JUMP SUITS, SHORTS, BOXER SHORTS, TOPS, STRETCH TOPS, TUBE TOPS, CROP TOPS, TANK TOPS, TANKINIS, HALTER TOPS, SWEAT SHIRTS, HOODED SWEAT SHIRTS, SWEAT JACKETS, SWEAT SHORTS, SWEAT PANTS, WRAPS, WARM-UP SUITS, JOGGING SUITS, TRACK SUITS, TRACK PANTS, PLAY SUITS, BLOUSES, SKIRTS, DRESSES, GOWNS, SWEATERS, VESTS, FLEECE VESTS, PULLOVERS, SNOW SUITS, PARKAS, CAPES, ANORAKS, PONCHOS, CLOAKS, SHRUGS, SHAWLS, PASHMINAS, JACKETS, DINNER JACKETS, REVERSIBLE JACKETS, WIND-RESISTANT JACKETS, SHELL JACKETS, SPORTS JACKETS, GOLF

SN 85-258,847. CAPITAL GARMENT CO. INC., MONTREAL, QUEBEC, CANADA, FILED 3-5-2011.

NIKKI JONES

THE MARK CONSISTS OF STANDARD CHARACTERS WITHOUT CLAIM TO ANY PARTICULAR FONT, STYLE, SIZE, OR COLOR.

THE NAME(S), PORTRAIT(S), AND/OR SIGNATURE(S) SHOWN IN THE MARK IDENTIFIES "NIKKI JONES", WHOSE CONSENT(S) TO REGISTER IS MADE OF RECORD.

FOR COATS; JACKETS (U.S. CLS. 22 AND 39).
MARK RADEMACHER, EXAMINING ATTORNEY

CLASS 25—(Continued).

AND SKI JACKETS, JEAN JACKETS, COATS, HEAVY COATS, OVER COATS, TOP COATS, PETTICOATS, BLAZERS, SUITS, TUXEDOS, CUMMERBUNDS, CUFFS, COLLARS, REMOVABLE COLLARS, COLLAR PROTECTORS, TURTLENECKS, CLOTH SKI BIBS, SWIMWEAR, BEACHWEAR, TENNIS WEAR, SURF WEAR, SKI WEAR, LAYETTES, INFANTWEAR, INFANTS SLEEPERS, BOOTIES, BABY BIBS NOT OF PAPER, CLOTH DIAPERS, CAPS, SWIM CAPS, BERETS, BEANIES, HATS, VISORS, HEADBANDS, WRIST BANDS, SWEAT BANDS, HEADWEAR, EAR MUFFS, APRONS, SCARVES, BANDANAS, BELTS, SUSPENDERS, NECKWEAR, TIES, NECKERCHIEFS, POCKET SQUARES, ASCOTS, UNDERWEAR, THERMAL UNDERWEAR, LONG UNDERWEAR, BRIEFS, SWIM AND BATHING TRUNKS, BRAS, SPORTS BRAS, BRASSIERES, BUS-TIERS, CORSETS, PANTIES, THONGS, G-STRINGS, GARTERS AND GARTER BELTS, TEDDIES, GIRDLES, FOUNDATION GARMENTS, SINGLET, SOCKS, LOUNGEWEAR, ROBES, UNDERCLOTHES, PAJAMAS, SLEEPWEAR, NIGHT GOWNS, NIGHTIES, LINGERIE, CAMISOLES, NEGLIGEEES, CHEMISES, CHEMISETTES, SLIPS, SARONGS, LEG WARMERS, HOSIERY, PANTY-HOSE, BODY STOCKINGS, KNEE HIGHS, LEGGINGS, TIGHTS, LEOTARDS, BODY SUITS, UNITARDS, BODY SHAPERS, GLOVES, MITTENS, RAIN SLICKERS, RAINWEAR, FOOTWEAR, SHOES, MULES, SNEAKERS, BOOTS, GALOSHES, SANDALS, FLIP-FLOPS, AND SLIPPERS (U.S. CLS. 22 AND 39).

SUZANNE BLANE, EXAMINING ATTORNEY

SN 85-259,732. BBC INTERNATIONAL LLC, BOCA RATON, FL. FILED 3-7-2011.

BOBBY C

THE MARK CONSISTS OF STANDARD CHARACTERS WITHOUT CLAIM TO ANY PARTICULAR FONT, STYLE, SIZE, OR COLOR.

THE NAME(S), PORTRAIT(S), AND/OR SIGNATURE(S) SHOWN IN THE MARK IDENTIFIES A LIVING INDIVIDUAL, WHOSE CONSENT(S) TO REGISTER IS MADE OF RECORD.

FOR FOOTWEAR (U.S. CLS. 22 AND 39).

LESLIE RICHARDS, EXAMINING ATTORNEY

CLASS 25—(Continued).

SN 85-260,971. BIGGIN INDUSTRIES INC., INDIAN HARBOR BEACH, FL. FILED 3-8-2011.



NO CLAIM IS MADE TO THE EXCLUSIVE RIGHT TO USE "FISHING & HUNTING", APART FROM THE MARK AS SHOWN.

THE MARK CONSISTS OF THE WORD "BIGGIN" WITH THE WORDS "FISHING & HUNTING" BELOW IT. A FISHING ROD WITH THE REEL IN THE CENTER OF THE TARGET WITH CROSS HAIRS ABOVE THE SECOND "I" IN THE TEXT "BIGGIN". ANTLERS ARE INCORPORATED TO THE LEFT SIDE OF THE LETTER "B" AND THE RIGHT SIDE OF THE LETTER "N". FISHING HOOKS ARE INCORPORATED TO THE BOTTOM PORTION OF THE LETTERS "G".

FOR ATHLETIC APPAREL, NAMELY, SHIRTS, PANTS, JACKETS, FOOTWEAR, HATS AND CAPS, ATHLETIC UNIFORMS; BEANIES; CAMOUFLAGE GLOVES; CAMOUFLAGE JACKETS; CAMOUFLAGE PANTS; CAMOUFLAGE SHIRTS; CAMOUFLAGE VESTS; FISHERMEN'S JACKETS; FISHING SHIRTS; FISHING VESTS; HOODED SWEATSHIRTS; HUNTING BOOT BAGS; HUNTING JACKETS; HUNTING PANTS; HUNTING SHIRTS; HUNTING VESTS; SHORT-SLEEVED OR LONG-SLEEVED T-SHIRTS; SKULLIES; SWEATSHIRTS; T-SHIRTS (U.S. CLS. 22 AND 39).

FIRST USE 2-11-2011; IN COMMERCE 2-11-2011.

DEZMONA MIZELLE, EXAMINING ATTORNEY

SN 85-261,023. ASTRAL BUOYANCY COMPANY, ASHEVILLE, NC. FILED 3-8-2011.

ASTRAL

THE MARK CONSISTS OF STANDARD CHARACTERS WITHOUT CLAIM TO ANY PARTICULAR FONT, STYLE, SIZE, OR COLOR.

FOR HATS; T-SHIRTS (U.S. CLS. 22 AND 39).

FIRST USE 8-0-2003; IN COMMERCE 8-0-2003.

THOMAS MANOR, EXAMINING ATTORNEY

CLASS 25—(Continued).

SN 85-261,687. JAMES MICHAEL CHANG, DBA BOX HEAD CLOTHING, LOS ANGELES, CA. FILED 3-9-2011.



THE MARK CONSISTS OF STYLIZED LETTERING "BH" APPEARING TO THE RIGHT OF A SQUARE CONTAINING TWO "X" LETTERS FOR EYES AND A SLANTED LINE FOR A MOUTH.
FOR (BASED ON USE IN COMMERCE) T-SHIRTS(-BASED ON INTENT TO USE) DENIMS (U.S. CLS. 22 AND 39).

FIRST USE 10-7-2007; IN COMMERCE 3-26-2009.
MICHAEL TANNER, EXAMINING ATTORNEY

CLASS 25—(Continued).

SN 85-263,155. THE WRAP, LLC, ORANGEBURG, NY. FILED 3-10-2011.



NO CLAIM IS MADE TO THE EXCLUSIVE RIGHT TO USE "WRAP", APART FROM THE MARK AS SHOWN.

THE MARK CONSISTS OF A CIRCLE, ENCASING A SMALLER BROKEN CIRCLE WITH THE BEGINNING OF THE SMALLER CIRCLE ATTACHED TO THE "B" IN "BOOTY" AND THE END OF THE SMALLER CIRCLE ATTACHED TO THE "W" IN "WRAP".

FOR CLOTHING ITEMS, NAMELY FABRIC TIED AROUND THE WAIST HAVING POCKETS (U.S. CLS. 22 AND 39).

KATHRYN COWARD, EXAMINING ATTORNEY

SN 85-262,485. KASSOF, MARK, ANN ARBOR, MI. FILED 3-9-2011.

MEATHEADS

THE MARK CONSISTS OF STANDARD CHARACTERS WITHOUT CLAIM TO ANY PARTICULAR FONT, STYLE, SIZE, OR COLOR.

FOR NOVELTY HATS FOR SPORTS FANS (U.S. CLS. 22 AND 39).

DAVID HOFFMAN, EXAMINING ATTORNEY

SN 85-264,285. GENTLEMAN JACK, ESSEX FELLS, NJ. FILED 3-11-2011.



SN 85-262,861. WILLIAMSON DEVELOPMENT INC., LAS VEGAS, NV. FILED 3-9-2011.

YN YOGA NADIS

THE MARK CONSISTS OF STANDARD CHARACTERS WITHOUT CLAIM TO ANY PARTICULAR FONT, STYLE, SIZE, OR COLOR.

NO CLAIM IS MADE TO THE EXCLUSIVE RIGHT TO USE "YOGA", APART FROM THE MARK AS SHOWN.

FOR YOGA PANTS; YOGA SHIRTS (U.S. CLS. 22 AND 39).

JASON TURNER, EXAMINING ATTORNEY

THE MARK CONSISTS OF A HUMAN SILHOUETTE WALKING WITH A SURFBOARD.

FOR CLOTHING, NAMELY, SHORTS, SHIRTS, SWEATSHIRTS, SWEATERS, ATHLETIC UNIFORMS, CAPS, HATS, WET SUITS, SOCKS, SCARVES; PROTECTIVE NECK GUARDS MADE OF NEOPRENE OR OTHER MATERIALS TO PREVENT WETSUIT CHAFING (U.S. CLS. 22 AND 39).

FIRST USE 7-31-2010; IN COMMERCE 7-31-2010.

SUSAN RICHARDS, EXAMINING ATTORNEY

CLASS 25—(Continued).

SN 85-265,318. UEB- THE BEST OF THE BEST, INC., DBA BIGG GIRLZ, HOUSTON, TX. FILED 3-12-2011.



THE COLOR(S) BLACK, BLUE, YELLOW, MAGENTA AND BROWN IS/ARE CLAIMED AS A FEATURE OF THE MARK.

THE MARK CONSISTS OF PLUS SIZE BROWN SKIN WOMAN WITH BACK TURNED, STANDING AND FACING TO HER RIGHT LOOKING OVER HER RIGHT SHOULDER WITH LONG BLACK CURLY HAIR WEARING BLUE HEAD BAND AND MATCHING BLUE DRESS. FACIAL FEATURES INCLUDE MAGENTA LIP STICK AND BROWN EYES. WEARING A SINGLE YELLOW HOOP EARRING AND MATCHING YELLOW BRACELET ON RIGHT ARM WITH LETTERS "BG" ON BRACELET. WEARING BLACK HIGH HEEL SHOES.

FOR WOMEN'S CLOTHING, NAMELY, SHIRTS, DRESSES, SKIRTS, BLOUSES (U.S. CLS. 22 AND 39).
AMY C. KEAN, EXAMINING ATTORNEY

CLASS 25—(Continued).

SN 85-266,103. RIGHTEOUS WALKS, LLC, TURLOCK, CA. FILED 3-14-2011.

RIGHTEOUS WALKS

THE MARK CONSISTS OF STANDARD CHARACTERS WITHOUT CLAIM TO ANY PARTICULAR FONT, STYLE, SIZE, OR COLOR.

FOR SHOES (U.S. CLS. 22 AND 39).

ANTHONY RINKER, EXAMINING ATTORNEY

SN 85-266,423. HER LOOK ENTERPRISES, LLC, SOUTH BURLINGTON, VT. FILED 3-14-2011.

SN 85-265,387. GLOVER, LAURA J, LOS ANGELES, CA. FILED 3-12-2011.

DAYDREAMER LA

THE MARK CONSISTS OF STANDARD CHARACTERS WITHOUT CLAIM TO ANY PARTICULAR FONT, STYLE, SIZE, OR COLOR.

NO CLAIM IS MADE TO THE EXCLUSIVE RIGHT TO USE "LA", APART FROM THE MARK AS SHOWN.

FOR DRESSES; KNIT TOPS; SWEAT SHIRTS; T-SHIRTS; TANK TOPS; TOPS; WOMEN'S CLOTHING, NAMELY, SHIRTS, DRESSES, SKIRTS, BLOUSES; WOVEN TOPS (U.S. CLS. 22 AND 39).

FIRST USE 2-1-2011; IN COMMERCE 3-5-2011.
ERNEST SHOSHO, EXAMINING ATTORNEY

PANTY PATROL

THE MARK CONSISTS OF STANDARD CHARACTERS WITHOUT CLAIM TO ANY PARTICULAR FONT, STYLE, SIZE, OR COLOR.

NO CLAIM IS MADE TO THE EXCLUSIVE RIGHT TO USE "PANTY", APART FROM THE MARK AS SHOWN.

FOR WOMEN'S UNDERWEAR (U.S. CLS. 22 AND 39).
JUSTINE D. PARKER, EXAMINING ATTORNEY

CLASS 25—(Continued).

SN 85-268,415. EUGENIA'S FASHION, BROOKLYN, NY.
FILED 3-16-2011.



NO CLAIM IS MADE TO THE EXCLUSIVE RIGHT TO USE "FASHION", APART FROM THE MARK AS SHOWN.

THE COLOR(S) MAROON, GOLD AND BROWN IS/ARE CLAIMED AS A FEATURE OF THE MARK.

THE MARK CONSISTS OF THE WORDING "EUGENIA'S FASHION" IN MAROON STYLIZED LETTERING APPEARING INSIDE OF A CARRIER THAT JOINS THE TOP OF THE LARGE STYLIZED LETTERS "EF". THE CARRIER AND THE LETTERS "EF" APPEAR IN GOLD WITH A BROWN OUTLINE. BENEATH THIS DESIGN APPEARS THE WORDING "WWW.EUGENIAFASHION.COM" IN BROWN STYLIZED LETTERING.

FOR CLOTHING, NAMELY, PANTS, SHIRTS, T-SHIRTS, HOODED T-SHIRTS, TROUSERS, PYJAMAS, JEANS, SHORTS, UNDERWEAR, VESTS; HEADWEAR, NAMELY, CAPS, SCARVES, BANDANAS AND HATS (U.S. CLS. 22 AND 39).

DEBRA LEE, EXAMINING ATTORNEY

SN 85-268,645. 360SWEATER COMPANY, LLC, SANTA MONICA, CA. FILED 3-16-2011.

SEA CASHMERE

THE MARK CONSISTS OF STANDARD CHARACTERS WITHOUT CLAIM TO ANY PARTICULAR FONT, STYLE, SIZE, OR COLOR.

OWNER OF U.S. REG. NOS. 3,848,802 AND 3,875,010.

NO CLAIM IS MADE TO THE EXCLUSIVE RIGHT TO USE "CASHMERE", APART FROM THE MARK AS SHOWN.

FOR BOTTOMS; DRESSES; GLOVES; HEADWEAR; JACKETS; SCARVES; TOPS; ALL OF THE FOREGOING MADE IN WHOLE OR SUBSTANTIAL PART OF CASHMERE (U.S. CLS. 22 AND 39).

GRETCHEN ULRICH, EXAMINING ATTORNEY

CLASS 25—(Continued).

SN 85-269,389. RENFRO CORPORATION, MOUNT AIRY, NC. FILED 3-17-2011.

ALASKAN NITS

THE MARK CONSISTS OF STANDARD CHARACTERS WITHOUT CLAIM TO ANY PARTICULAR FONT, STYLE, SIZE, OR COLOR.

NO CLAIM IS MADE TO THE EXCLUSIVE RIGHT TO USE "KNITS", APART FROM THE MARK AS SHOWN.

FOR SOCKS (U.S. CLS. 22 AND 39).

FIRST USE 8-0-2010; IN COMMERCE 8-0-2010.

EMILY CHUO, EXAMINING ATTORNEY

SN 85-270,248. LEJH LLC, ATLANTA, GA. FILED 3-17-2011.



THE NAME SHOWN IN THE MARK IDENTIFIES EFRAN LEBRON, WHOSE CONSENT TO REGISTER IS MADE OF RECORD.

THE MARK CONSISTS OF A STYLIZED, SCRIPT LETTER "E" INSIDE A RECTANGULAR BORDER, ALL ABOVE THE STYLIZED, SCRIPT WORDING "E. LEBRON".

FOR BRIDESMAID DRESSES; EVENING GOWNS; WEDDING GOWNS (U.S. CLS. 22 AND 39).

CORY BOONE, EXAMINING ATTORNEY

SN 85-270,431. MORSE, KIZE, CANYON, TX. AND MORSE, MAE, CANYON, TX. FILED 3-18-2011.

Dependent Shorts

THE MARK CONSISTS OF STANDARD CHARACTERS WITHOUT CLAIM TO ANY PARTICULAR FONT, STYLE, SIZE, OR COLOR.

NO CLAIM IS MADE TO THE EXCLUSIVE RIGHT TO USE "SHORTS", APART FROM THE MARK AS SHOWN.

FOR BOXER SHORTS (U.S. CLS. 22 AND 39).

JASON TURNER, EXAMINING ATTORNEY

CLASS 25—(Continued).

SN 85-270,690. JULIANELLI, JANE, WAINSCOTT, NY.
FILED 3-18-2011.



THE SIGNATURE SHOWN IN THE MARK IDENTIFIES A LIVING INDIVIDUAL WHOSE CONSENT IS OF RECORD. THE COLOR(S) GOLD IS/ARE CLAIMED AS A FEATURE OF THE MARK.

THE MARK CONSISTS OF THE BRAND SIGNATURE AND LOGO "JULIANELLI" APPEARING IN GOLD.

FOR FOOTWEAR OF MEN AND WOMEN, HOSIERY, SKIRTS AND DRESSES, BLOUSES, PANTS, WOMEN'S SUITS, T-SHIRTS, TANK TOPS, KNIT SHIRTS, COATS, HATS, SCARVES, AND GLOVES (U.S. CLS. 22 AND 39).
GISELLE AGOSTO, EXAMINING ATTORNEY

CLASS 25—(Continued).

SN 85-272,240. SHERELLE MOORE, BROOKLYN, NY.
FILED 3-21-2011.

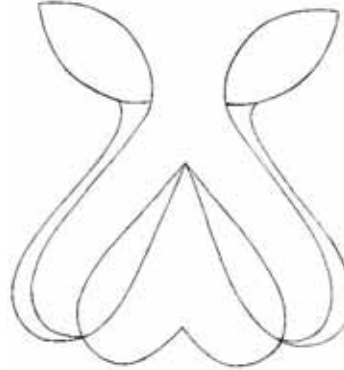

THE MARK CONSISTS OF AN UPSIDE DOWN HEART WITH AN ABSTRACT DESIGN OF A PAIR OF HIGH-HEELED SHOES WITH THE HEEL OF EACH SHOE INTERSECTING/OVERLAPPING WITH THE HEART DESIGN. EACH SHOE REPRESENTS/RESEMBLES A LETTER "L".

FOR FOOTWEAR FOR WOMEN (U.S. CLS. 22 AND 39).
MEGHAN REINHART, EXAMINING ATTORNEY

SN 85-272,458. TIMOTHY RUSSELL WARMOTH, VISTA, CA.
AND ALEXANDRA ANDERSON MARINO, VISTA, CA.
FILED 3-21-2011.

Cool for a Fool

THE MARK CONSISTS OF STANDARD CHARACTERS WITHOUT CLAIM TO ANY PARTICULAR FONT, STYLE, SIZE, OR COLOR.

FOR CLOTHING, NAMELY, T-SHIRTS, SWEAT JACKETS, SWEAT SHIRTS, HATS, CAPS, V-NECK SWEATERS, TANK TOPS, SOCKS, SWEAT PANTS, PANTS, SHIRTS, SCARVES, JACKETS, UNDERWEAR, GLOVES (U.S. CLS. 22 AND 39).

TAMARA FRAZIER, EXAMINING ATTORNEY

SN 85-271,856. HEDBERG, JEFFREY, ROCKFORD, IL.
FILED 3-21-2011.

MANPOLAR

THE MARK CONSISTS OF STANDARD CHARACTERS WITHOUT CLAIM TO ANY PARTICULAR FONT, STYLE, SIZE, OR COLOR.

FOR SPORTS WEAR AND MOTOR CYCLE WEAR, NAMELY, T-SHIRTS, SHIRTS, TROUSERS, JACKETS, HOODED T-SHIRTS, FLEECE TOPS, FLEECE BOTTOMS, JEANS; HEAD WEAR, NAMELY, HATS AND CAPS; FOOTWEAR, NAMELY, SPORTS SHOES, BOOTS (U.S. CLS. 22 AND 39).

ELLEN BURNS, EXAMINING ATTORNEY

SN 85-272,517. FLORACAROLINA, LLC, WHITAKERS, NC.
FILED 3-21-2011.

The Collard Shirt

THE MARK CONSISTS OF STANDARD CHARACTERS WITHOUT CLAIM TO ANY PARTICULAR FONT, STYLE, SIZE, OR COLOR.

NO CLAIM IS MADE TO THE EXCLUSIVE RIGHT TO USE "SHIRT", APART FROM THE MARK AS SHOWN.

FOR SHORT-SLEEVED OR LONG-SLEEVED T-SHIRTS (U.S. CLS. 22 AND 39).

FIRST USE 3-21-2011; IN COMMERCE 3-21-2011.
NICHOLAS ALTREE, EXAMINING ATTORNEY

CLASS 25—(Continued).

SN 85-272,628. TRAVIS SIFLINGER, SIMI VALLEY, CA.
FILED S.R. 3-21-2011; AM. P.R. 7-12-2011.



THE MARK CONSISTS OF A THIN ITALICIZED "4" NESTED INSIDE OF A BOLD "4".

FOR BELTS FOR CLOTHING; BOXER BRIEFS; BOXER SHORTS; BRAS; CHILDREN'S AND INFANT'S APPAREL, NAMELY, JUMPERS, OVERALL SLEEPWEAR, PAJAMAS, ROMPERS AND ONE-PIECE GARMENTS; FOOTWEAR; GLOVES; HEADWEAR; JACKETS; JEANS; JERSEYS; LINGERIE; LOUNGEWEAR; MEN'S UNDERWEAR; PANTS; POLO SHIRTS; SHIRTS; SHORTS; SOCKS; T-SHIRTS; TANK TOPS; TRUNKS; WOMEN'S UNDERWEAR (U.S. CLS. 22 AND 39).

FIRST USE 3-6-2010; IN COMMERCE 3-6-2010.
BARBARA GAYNOR, EXAMINING ATTORNEY

CLASS 25—(Continued).

SN 85-273,760. MCGILL, DEBRA, PLYMOUTH, MN. FILED 3-22-2011.



NO CLAIM IS MADE TO THE EXCLUSIVE RIGHT TO USE "JAMMIE CAMI" AND "SMOOTH, SHAPE AND SUPPORT", APART FROM THE MARK AS SHOWN.

THE STIPPLING IS FOR SHADING PURPOSES ONLY.

THE MARK CONSISTS OF A TANK TOP SHIRT WITH A FLOWER SUPERIMPOSED OVER THE NECKLINE TO EXTEND OVER THE BUST WITH THE STYLIZED WORDING "JAMMIE CAMI" APPEARING IN THE FLOWER AND "SMOOTH, SHAPE AND SUPPORT IT FEELS GOOD" ON THE BOTTOM OF THE TANK TOP.

FOR SUPPORTIVE TOPS FOR SLEEPWEAR AND LOUNGEWEAR THAT PROVIDE BUST SUPPORT, SHAPE AND COMFORT (U.S. CLS. 22 AND 39).

JENNIFER MARTIN, EXAMINING ATTORNEY

SN 85-273,504. TREK APPAREL COMPANY, LLC, HOUSTON, TX. FILED 3-22-2011.

RICK MARTIN

THE MARK CONSISTS OF STANDARD CHARACTERS WITHOUT CLAIM TO ANY PARTICULAR FONT, STYLE, SIZE, OR COLOR.

THE NAME(S), PORTRAIT(S), AND/OR SIGNATURE(S) SHOWN IN THE MARK IDENTIFIES FREDERICK "RICK MARTIN", WHOSE CONSENT(S) TO REGISTER IS MADE OF RECORD.

FOR GOLF CAPS; GOLF SHIRTS; GOLF SHOES; GOLF PANTS, SHIRTS AND SKIRTS; VISORS, GLOVES, RAINWEAR, CLOTHING, NAMELY, T-SHIRTS, SOCKS, JACKETS, COATS, TURTLENECKS, LONG SLEEVE T-SHIRTS, VESTS, SWEATERS, AND SWEATSHIRTS (U.S. CLS. 22 AND 39).

JAY FLOWERS, EXAMINING ATTORNEY

SN 85-273,791. TCJ MANUFACTURING, LLC, LOS ANGELES, CA. FILED 3-22-2011.

VELVET BUTTERFLY

THE MARK CONSISTS OF STANDARD CHARACTERS WITHOUT CLAIM TO ANY PARTICULAR FONT, STYLE, SIZE, OR COLOR.

NO CLAIM IS MADE TO THE EXCLUSIVE RIGHT TO USE "VELVET", APART FROM THE MARK AS SHOWN.

FOR BELTS; BLOUSES; DRESSES; JACKETS; PANTS; SHIRTS; SHOES; SHORTS; SKIRTS; SKORTS; SWEAT PANTS; SWEAT SHIRTS; SWEATERS; T-SHIRTS; VESTS (U.S. CLS. 22 AND 39).

MATTHEW MCDOWELL, EXAMINING ATTORNEY

CLASS 25—(Continued).

SN 85-273,846. TERRA'S DANCEWEAR AND DALLA-SWEAR LLC, DALLAS, TX. FILED 3-22-2011.



NO CLAIM IS MADE TO THE EXCLUSIVE RIGHT TO USE "UNIFORMS", APART FROM THE MARK AS SHOWN. THE MARK CONSISTS OF A STYLIZED DEPICTION OF A FEMALE FOOD SERVER FROM THE WAIST UP HOLDING A TRAY WITHIN A DOUBLE CIRCLE. HER ARM AND TRAY ARE SUPERIMPOSED OVER THE DOUBLE CIRCLE. THE WORDING "BREASTAURANT UNIFORMS" IS PRESENTED IN STYLIZED FONT WITHIN THE BAND FORMED BY THE DOUBLE CIRCLE. "BREASTAURANT" EXTENDS OVER THE TOP HALF OF THE BAND AND "UNIFORMS" APPEARS IN THE LOWER RIGHT SIDE OF THE BAND. THE DESIGN ELEMENT AND WORDING APPEAR ON A SHADED SQUARE BACKGROUND WHICH IS USED TO SHOW MARK PLACEMENT AND IS NOT CLAIMED AS A FEATURE OF THE MARK.

FOR PANTS; SUITS; UNIFORMS; WOMEN'S CLOTHING, NAMELY, SHIRTS, DRESSES, SKIRTS, BLOUSES (U.S. CLS. 22 AND 39).

FIRST USE 1-21-2010; IN COMMERCE 1-21-2010.
GRETCHEN ULRICH, EXAMINING ATTORNEY

SN 85-273,851. TERRA'S DANCEWEAR AND DALLA-SWEAR LLC, DALLAS, TX. FILED 3-22-2011.

BREASTAURANT UNIFORMS

THE MARK CONSISTS OF STANDARD CHARACTERS WITHOUT CLAIM TO ANY PARTICULAR FONT, STYLE, SIZE, OR COLOR.

NO CLAIM IS MADE TO THE EXCLUSIVE RIGHT TO USE "UNIFORMS", APART FROM THE MARK AS SHOWN. FOR PANTS; SUITS; UNIFORMS; WOMEN'S CLOTHING, NAMELY, SHIRTS, DRESSES, SKIRTS, BLOUSES (U.S. CLS. 22 AND 39).

FIRST USE 1-14-2008; IN COMMERCE 1-14-2008.
GRETCHEN ULRICH, EXAMINING ATTORNEY

CLASS 25—(Continued).

SN 85-274,058. AFFLICTION HOLDINGS LLC, SEAL BEACH, CA. FILED 3-22-2011.

AFFLICTION AMERICAN METAL

THE MARK CONSISTS OF STANDARD CHARACTERS WITHOUT CLAIM TO ANY PARTICULAR FONT, STYLE, SIZE, OR COLOR.

OWNER OF U.S. REG. NOS. 3,109,069, 3,915,077 AND OTHERS.

NO CLAIM IS MADE TO THE EXCLUSIVE RIGHT TO USE "AMERICAN", APART FROM THE MARK AS SHOWN. FOR CLOTHING, NAMELY, T-SHIRTS, SHIRTS, TANK TOPS, BABY T-SHIRTS, THERMAL SHIRTS, LONG SLEEVE SHIRTS, SHORT SLEEVE SHIRTS, WOVEN SHIRTS, POLO SHIRTS, DRESS SHIRTS, JACKETS, LEATHER JACKETS, DRESSES, SKIRTS, PANTS, DENIM PANTS, DENIM SHORTS, SHORTS, BOARD SHORTS, SWEATSHIRTS, HOODED SWEATSHIRTS, SWEATERS, LEGGINGS, BEANIES, HATS, CAPS, BELTS, FOOTWEAR, NAMELY, CANVAS SHOES, LOW TOP SHOES, HIGH TOP SHOES, AND THONGS (U.S. CLS. 22 AND 39).

TAMARA FRAZIER, EXAMINING ATTORNEY

SN 85-274,074. THIS IS B.S., INC., BLOOMINGTON, IL. FILED 3-23-2011.



NO CLAIM IS MADE TO THE EXCLUSIVE RIGHT TO USE "INC.", APART FROM THE MARK AS SHOWN.

THE MARK CONSISTS OF THE STYLIZED IMAGE OF A BULL, WITH THE WORDING "THIS IS B.S., INC.".

FOR BOTTOMS; HATS; HEADWEAR; SHIRTS; TOPS (U.S. CLS. 22 AND 39).

DEIRDRE ROBERTSON, EXAMINING ATTORNEY

CLASS 25—(Continued).

SN 85-274,089. SARWAR, SHAREEN, MIAMI BEACH, FL. FILED 3-23-2011.

WE ARE VINTAGE MAVENS

THE MARK CONSISTS OF STANDARD CHARACTERS WITHOUT CLAIM TO ANY PARTICULAR FONT, STYLE, SIZE, OR COLOR.

NO CLAIM IS MADE TO THE EXCLUSIVE RIGHT TO USE "VINTAGE", APART FROM THE MARK AS SHOWN.

FOR BLOUSES; BOTTOMS; COATS; DRESSES; JUMPSUITS; PANTS; ROMPERS; SCARVES; SHIRTS; SHORTS; TOPS (U.S. CLS. 22 AND 39).

FIRST USE 3-18-2011; IN COMMERCE 3-18-2011.
DAWN HAN, EXAMINING ATTORNEY

SN 85-274,174. JEFFERIES SOCKS, LLC, BURLINGTON, NC. FILED 3-23-2011.



NO CLAIM IS MADE TO THE EXCLUSIVE RIGHT TO USE "SOCKS", APART FROM THE MARK AS SHOWN.

THE COLOR(S) BLUE, PURPLE, GREEN, ORANGE AND YELLOW IS/ARE CLAIMED AS A FEATURE OF THE MARK.

THE MARK CONSISTS OF THE WORD "JEFFERIES" IN ALL BLUE LETTERS AND THE WORD "SOCKS" HAVING A PURPLE "S", A GREEN "O", A BLUE "C", AN ORANGE "K" AND A YELLOW "S".

FOR SOCKS (U.S. CLS. 22 AND 39).
FIRST USE 8-0-2008; IN COMMERCE 8-0-2008.
ROBIN CHOSID, EXAMINING ATTORNEY

SN 85-274,706. STONE, DAVID R., LANSING, IL. FILED 3-23-2011.

REEFERWEAR

THE MARK CONSISTS OF STANDARD CHARACTERS WITHOUT CLAIM TO ANY PARTICULAR FONT, STYLE, SIZE, OR COLOR.

FOR CLOTHING, NAMELY, T-SHIRTS, HOODED SWEATSHIRTS, SWIMSUITS, HATS, BEANIES, WOMEN'S CAMISOLES, TANK TOPS, HALTER TOPS, SHORTS, LONG SLEEVE SHIRTS (U.S. CLS. 22 AND 39).

PAULA MAHONEY, EXAMINING ATTORNEY

CLASS 25—(Continued).

SN 85-274,948. ARMORTERIA, CAMBRIA HEIGHTS, NY. FILED 3-23-2011.



THE MARK CONSISTS OF THE TERMS "HALO" ABOVE THE TERMS "SANI- CUFFS" WITH THE LETTER "H" INSIDE OF A CIRCLE WITH A PARTIAL RING AROUND IT.

FOR WRISTBANDS (U.S. CLS. 22 AND 39).
FIRST USE 12-26-2010; IN COMMERCE 1-1-2011.
ANTHONY RINKER, EXAMINING ATTORNEY

SN 85-275,494. POSVAR, RANDY, TRACY, CA. FILED 3-24-2011.

doin dirt industries.

THE MARK CONSISTS OF STANDARD CHARACTERS WITHOUT CLAIM TO ANY PARTICULAR FONT, STYLE, SIZE, OR COLOR.

NO CLAIM IS MADE TO THE EXCLUSIVE RIGHT TO USE "INDUSTRIES", APART FROM THE MARK AS SHOWN.

FOR HATS; SHIRTS; SHORTS; SWEATERS; TANK TOPS (U.S. CLS. 22 AND 39).

ALYSSA STEEL, EXAMINING ATTORNEY

SN 85-275,530. KASWIT, INC., LA QUINTA, CA. FILED 3-24-2011.



OWNER OF U.S. REG. NO. 3,955,871.

THE MARK CONSISTS OF THE TERM "STASH 'N DASH" WITH A DESIGN OF A CURVED LINE OF NON-UNIFORM WIDTH CONNECTING WITH THE HORIZONTAL LINE IN THE LETTER "T" IN THE WORD "STASH" AND EXTENDING TO THE RIGHT AND SUPERIMPOSED OVER THE LETTER "N" IN THE MIDDLE OF THE LOGO.

FOR SCARVES (U.S. CLS. 22 AND 39).
FIRST USE 11-1-2010; IN COMMERCE 11-1-2010.
KAELIE KUNG, EXAMINING ATTORNEY

CLASS 25—(Continued).

SN 85-275,760. ROBINSON, MARY H, LAWRENCEVILLE, GA. FILED 3-24-2011.



THE MARK CONSISTS OF THE LETTERS "JMATG" IN STYLIZED FONT BELOW AND PARTIALLY SURROUNDED BY A SEMI-CIRCULAR CURVED LINE AND THE STYLIZED WORDS "JUST ME AND THE GIRLS" AND "DOING OUR THANG".

FOR A-SHIRTS; ADULT NOVELTY GAG CLOTHING ITEM, NAMELY, SOCKS; ANKLE SOCKS; ANKLETS; ANTI-PERSPIRANT SOCKS; APPAREL FOR DANCERS, NAMELY, TEE SHIRTS, SWEATSHIRTS, PANTS, LEGGINGS, SHORTS AND JACKETS; ATHLETIC APPAREL, NAMELY, SHIRTS, PANTS, JACKETS, FOOTWEAR, HATS AND CAPS, ATHLETIC UNIFORMS; ATHLETIC FOOTWEAR; BABY TOPS; BALLOON PANTS; BANDEAU TOPS; BASEBALL CAPS; BASEBALL CAPS AND HATS; BASEBALL SHOES; BASEBALL UNIFORMS; BASELAYER TOPS; BASKETBALL SNEAKERS; BATH SLIPPERS; BATHING CAPS; BATHING COSTUMES; BATHING COSTUMES FOR WOMEN; BATHING SUITS; BATHING SUITS FOR MEN; BATHING TRUNKS; BATHROBES; BEACH COVER-UPS; BEACH COVERUPS; BEACH FOOTWEAR; BEACH SHOES; BEACHWEAR; BED JACKETS; BELTS; BELTS FOR CLOTHING; BELTS MADE FROM IMITATION LEATHER; BELTS MADE OF LEATHER; BELTS MADE OUT OF CLOTH; BELTS OF TEXTILE; BERMUDA SHORTS; BIB OVERALLS; BIB OVERALLS FOR HUNTING; BIB SHORTS; BICYCLE GLOVES; BICYCLING GLOVES; BIKINIS; BLAZERS; BLOUSES; BOARD SHORTS; BODY SHIRTS; BODY SUITS; BOMBER JACKETS; BOXER BRIEFS; BOXER SHORTS; BOXING SHORTS; BRAS; BRIEFS; BUCKET CAPS; BUTTON DOWN SHIRTS; BUTTON-FRONT ALOHA SHIRTS; CAMISOLES; CAMOUFLAGE GLOVES; CAMOUFLAGE JACKETS; CAMOUFLAGE PANTS; CAMOUFLAGE SHIRTS; CAMP SHIRTS; CAP PEAKS; CAP VISORS; CAPES; CAPES FOR USE IN SALONS AND BARBER SHOPS; CAPRI PANTS; CAPS; CAPS WITH VISORS; CARDIGANS; CARGO PANTS; CHEF'S COATS; CHEF'S HATS; CHILDREN'S AND INFANT'S APPAREL, NAMELY, JUMPERS, OVERALL SLEEPWEAR, PAJAMAS, ROMPERS AND ONE-PIECE GARMENTS; CHILDREN'S AND INFANTS' APPAREL TREATED WITH FIRE AND HEAT RETARDANTS, NAMELY, JUMPERS, OVERALL SLEEPWEAR, PAJAMAS, ROMPERS AND ONE-PIECE GARMENTS; CHOIR ROBES; CLIMBING FOOTWEAR; CLOGS; CLOTHING FOR ATHLETIC USE, NAMELY, PADDED PANTS; CLOTHING FOR ATHLETIC USE, NAMELY, PADDED SHIRTS; CLOTHING FOR ATHLETIC USE, NAMELY, PADDED SHORTS; CLOTHING FOR BABIES, TODDLERS AND CHILDREN, TREATED WITH FIRE AND HEAT RETARDANTS, NAMELY, PAJAMAS, JACKETS, SHIRTS, PANTS, JUMPERS; CLOTHING FOR WEAR IN JUDO PRACTICES; CLOTHING FOR WEAR IN WRESTLING GAMES; CLOTHING SHIELDS, NAMELY, PADS APPLIED TO THE UNDERARMS OF SHIRTS, BLOUSES AND SWEATERS; CLOTHING, NAMELY, ARM WARMERS; CLOTHING, NAMELY, COWLS AND SMOKE RING SCARVES; CLOTHING, NAMELY, HAND-WARMERS; CLOTHING, NAMELY, KNEE WARMERS; COATS; COATS FOR MEN AND WOMEN; COATS MADE OF COTTON; COATS OF DENIM; COLLARED SHIRTS; CREW NECK SWEATERS; CROP PANTS; CROP TOPS; CROSS-COUNTRY GLOVES; CYCLING SHORTS; CYCLISTS' JERSEYS; DENIM JACKETS; DENIMS; DISPOSABLE UNDERWEAR; DOWN JACKETS; DRESS PANTS;

CLASS 25—(Continued).

DRESS SHIRTS; DRESS SUITS; DRESSING GOWNS AND BATH ROBES; DUNGAREES; EAR BANDS; EAR MUFFS; EAR WARMERS; FABRIC BELTS; FINGERLESS GLOVES; FISHERMEN'S JACKETS; FISHING SHIRTS; FITTED SWIMMING COSTUMES WITH BRA CUPS; FLEECE PULLOVERS; FLEECE SHORTS; FLEECE TOPS; FLIP FLOPS; FLOOD PANTS; FOOTWEAR; FOOTWEAR FOR MEN; FOOTWEAR FOR MEN AND WOMEN; FOOTWEAR FOR TRACK AND FIELD ATHLETICS; FOOTWEAR FOR WOMEN; FOOTWEAR MADE OF WOOD; FOOTWEAR NOT FOR SPORTS; FOOTWEAR, NAMELY, PUMPS; FOOTWEAR, NAMELY, RUBBERS; FOOTWEAR, NAMELY, WORK BOOTS; FUR COATS AND JACKETS; FUR HATS; FUR JACKETS; GLOVES; GLOVES AS CLOTHING; GLOVES FOR APPAREL; GLOVES FOR PERSONAL HAND CONDITIONING USE; GLOVES INCLUDING THOSE MADE OF SKIN, HIDE OR FUR; GOLF CAPS; GOLF PANTS, SHIRTS AND SKIRTS; GOLF SHIRTS; GOLF SHORTS; GYM PANTS; GYM SHORTS; GYM SUITS; HALTER TOPS; HAT BANDS; HATS; HATS FOR INFANTS, BABIES, TODDLERS AND CHILDREN; HEAD SCARVES; HEAD WEAR; HEAVY COATS; HEAVY JACKETS; HOODED PULLOVERS; HOODED SWEAT SHIRTS; HOODS; HOSIERY; HUNTING JACKETS; HUNTING PANTS; HUNTING SHIRTS; INFANT WEAR; INFANT WEARABLE BLANKETS; INSOLES FOR FOOTWEAR; JACKET LINERS; JACKETS; JACKETS AND SOCKS; JAPANESE STYLE SOCKS (TABI COVERS); JAPANESE STYLE SOCKS (TABI); JEANS; JEGGINGS, NAMELY, PANTS THAT ARE PARTIALLY JEANS AND PARTIALLY LEGGINGS; JERSEYS; JOGGING PANTS; JOGGING SUITS; JUMP SUITS; JUMPSUITS; KNEE HIGHS; KNEE-HIGH STOCKINGS; KNIT JACKETS; KNIT SHIRTS; KNIT SKIRTS; KNIT TOPS; KNITTED CAPS; KNITTED GLOVES; KNITTED UNDERWEAR; KNOT CAPS; KNOTTED CAPS; LADIES' UNDERWEAR; LEATHER BELTS; LEATHER COATS; LEATHER HATS; LEATHER JACKETS; LEATHER PANTS; LEATHER SHIRTS; LEG SHIELDING DEVICE, ATTACHABLE TO AND DETACHABLE FROM A PERSON'S PANTS, COMPRISED OF PADDING TO SHIELD THE LEGS FROM FLYING DEBRIS WHEN MOWING WITH A STRING TRIMMER; LEG WARMERS; LEGGINS; LEOTARDS AND TIGHTS FOR WOMEN, MEN AND CHILDREN OF NYLON, COTTON OR OTHER TEXTILE FIBERS; LIGHT-REFLECTING COATS; LIGHT-REFLECTING JACKETS; LONG JACKETS; LONG SLEEVE PULLOVERS; LONG UNDERWEAR; LONG-SLEEVED SHIRTS; LOUNGE PANTS; LOUNGEWEAR; MEN'S AND WOMEN'S JACKETS, COATS, TROUSERS, VESTS; MEN'S DRESS SOCKS; MEN'S SOCKS; MEN'S UNDERWEAR; MINISKIRTS; MITTENS; MITTENS MODIFIED TO COVER THE HAND AND AN ANIMAL LEASH HANDLE OR OTHER LOOP; MOCK TURTLE-NECK SWEATERS; MOISTURE-WICKING SPORTS PANTS; MOISTURE-WICKING SPORTS SHIRTS; MONEY BELTS; MORNING COATS; MOTORCYCLE GLOVES; MOTORCYCLE JACKETS; MUFFLERS; MUFFS; MUSCLE TOPS; NECKTIES; NIGHT SHIRTS; NON-DISPOSABLE CLOTH TRAINING PANTS; NON-SLIP SOCKS; NURSE OVERALLS; NURSE PANTS; ONE-PIECE PLAY SUITS; OPEN-NECKED SHIRTS; OUTDOOR GLOVES; OUTDOOR MITTENS; OUTER JACKETS; OVER COATS; OVER SHIRTS; OVERALLS; OVERALLS FOR USE IN SALONS AND BARBER SHOPS; PADDED JACKETS; PADDING JACKETS; PAJAMA BOTTOMS; PAJAMAS; PAJAMAS TREATED WITH FIRE AND HEAT RETARDANTS; PANTIES; PANTIES, SHORTS AND BRIEFS; PANTS; PAPER HATS FOR USE AS CLOTHING ITEMS; PAPER SHOES USED WHEN GOING THROUGH METAL DETECTORS TO KEEP FEET AND SOCKS CLEAN; PARTS OF CLOTHING, NAMELY, GUSSETS FOR TIGHTS, GUSSETS FOR STOCKINGS, GUSSETS FOR BATHING SUITS, GUSSETS FOR UNDERWEAR, GUSSETS FOR LEOTARDS AND GUSSETS FOR FOOTLETS; PARTY HATS; PERSPIRATION ABSORBENT STRAP TO BE USED IN THE BILL OF A HAT; PETTI-PANTS; PIQUE SHIRTS; PLAY SUITS; POLO KNIT TOPS; POLO SHIRTS; PONCHOS; PULLOVERS; PUMPS; RAIN COATS; RAIN HATS; RAIN JACKETS; RAIN SUITS; RAIN WEAR; RAINPROOF JACKETS; REVERSIBLE JACKETS; RIDING COATS; RIDING GLOVES; ROBES; RUGBY SHIRTS; RUGBY SHORTS; RUGBY TOPS; RUNNING SUITS; SANDAL-CLOGS; SANDALS; SANDALS AND BEACH SHOES; SARONGS; SASHES; SCARVES; SCIENTIFIC AND TECHNOLOGICAL APPAREL, NAMELY, SHIRTS,

CLASS 25—(Continued).

PANTS, JACKETS, FOOTWEAR, HATS AND CAPS, UNIFORMS; SEDGE HATS (SUGE-GASA); SHAWLS; SHAWLS AND HEADSCARVES; SHAWLS AND STOLEES; SHELL JACKETS; SHIFTS; SHIRT FRONTS; SHIRT INSERTS, NAMELY, DICKIES; SHIRT YOKES; SHIRTS; SHIRTS AND SHORT-SLEEVED SHIRTS; SHIRTS AND SLIPS; SHIRTS FOR INFANTS, BABIES, TODDLERS AND CHILDREN; SHIRTS FOR SUITS; SHOE COVERS FOR USE WHEN WEARING SHOES; SHORT OVERCOAT FOR KIMONO (HAORI); SHORT PETTICOATS; SHORT SETS; SHORT TROUSERS; SHORT-SLEEVED OR LONG-SLEEVED T-SHIRTS; SHORT-SLEEVED SHIRTS; SHORTS; SHOULDER SCARVES; SHOWER CAPS; SILK SCARVES; SKI GLOVES; SKI JACKETS; SKI PANTS; SKI SUITS; SKI WEAR; SKIRT SUITS; SKIRTS; SKIRTS AND DRESSES; SKORTS; SKULL CAPS; SLEEP PANTS; SLEEP SHIRTS; SLEEPING GARMENTS; SLEEPWEAR; SLEEPWEAR TREATED WITH FIRE AND HEAT RETARDANTS; SLEEVED OR SLEEVELESS JACKETS; SLEEVELESS JERSEYS; SLEEVES WORN SEPARATE AND APART FROM BLOUSES, SHIRTS AND OTHER TOPS; SLIDING SHORTS; SLIPPER SOCKS; SLIPPERS; SLIPS; SMALL HATS; SMOKING JACKETS; SNEAKERS; SNOW PANTS; SNOWBOARD GLOVES; SNOWBOARD JACKETS; SNOWBOARD MITTENS; SNOWBOARD PANTS; SOCK SUSPENDERS; SOCKS; SOCKS AND STOCKINGS; SOLES FOR FOOTWEAR; SPORT COATS; SPORT SHIRTS; SPORTS BRA; SPORTS BRAS; SPORTS CAPS AND HATS; SPORTS JACKETS; SPORTS JERSEYS; SPORTS JERSEYS AND BREECHES FOR SPORTS; SPORTS PANTS; SPORTS SHIRTS; SPORTS SHIRTS WITH SHORT SLEEVES; STRAPLESS BRAS; STRAPS FOR BRAS; STRETCH PANTS; STUFF JACKETS; SUEDE JACKETS; SUIT COATS; SUN LEGGINGS; SUN VISORS; SURF WEAR; SWEAT JACKETS; SWEAT PANTS; SWEAT SHIRTS; SWEAT SHORTS; SWEAT SUITS; SWEATERS; SWEATSHIRTS; SWIM CAPS; SWIM SUITS; SWIM TRUNKS; SWIM WEAR; SWIM WEAR FOR GENTLEMEN AND LADIES; SWIMMING CAPS; SWIMMING TRUNKS; SWIMWEAR; T-SHIRTS; TANK TOPS; TANK-TOPS; TAP PANTS; TEE SHIRTS; TENNIS WEAR; THERMAL SOCKS; THERMAL UNDERWEAR; THONGS; TIGHTS; TIPS FOR FOOTWEAR; TOBOGGAN HATS, PANTS AND CAPS; TOE CAPS; TOP COATS; TOPS; TRACK JACKETS; TRACK PANTS; TRACK SUITS; TRAINING SUITS; TRAVEL CLOTHING CONTAINED IN A PACKAGE COMPRISING REVERSIBLE JACKETS, PANTS, SKIRTS, TOPS AND A BELT OR SCARF; TRENCH COATS; TRIATHLON CLOTHING, NAMELY, TRIATHLON TIGHTS, TRIATHLON SHORTS, TRIATHLON SINGLET, TRIATHLON SHIRTS, TRIATHLON SUITS; TRUNKS; TUBE TOPS; TUNICS; TURTLE NECK SHIRTS; TURTLENECK PULLOVERS; TURTLENECK SWEATERS; UNDERGARMENT ACCESSORIES, NAMELY, REMOVABLE SILICONE BUTTOCK ENHANCER PADS; UNDERGARMENTS; UNDERGARMENTS, NAMELY, WASPIES; UNDERWEAR; UNDERWEAR, NAMELY, BOY SHORTS; V-NECK SWEATERS; VESTED SUITS; VISCOUS GEL POLYMER SOLD AS A COMPONENT OF FINISHED CUSTOM CUSHIONED FOOTWEAR FOR NON-ORTHOPEDIC PURPOSES AND APPAREL; VISORS; WAIST BELTS; WALKING SHORTS; WARM UP SUITS; WARM-UP SUITS; WATER REPELLENT FOOTWEAR; WATER SOCKS; WATERPROOF FOOTWEAR; WATERPROOF JACKETS AND PANTS; WEARABLE BLANKETS IN THE NATURE OF BLANKETS WITH SLEEVES; WEARABLE GARMENTS AND CLOTHING, NAMELY, SHIRTS; WET SUIT GLOVES; WIND COATS; WIND PANTS; WIND RESISTANT JACKETS; WIND SHIRTS; WIND-JACKETS; WOMEN'S ATHLETIC TOPS WITH BUILT-IN BRAS; WOMEN'S CLOTHING, NAMELY, SHIRTS, DRESSES, SKIRTS, BLOUSES; WOMEN'S FOLDABLE SLIPPERS; WOMEN'S HATS AND HOODS; WOMEN'S TOPS, NAMELY, CAMIS; WOMEN'S UNDERWEAR; WOODEN SHOES; WOOLLEN SOCKS; WOOLLY HATS; WORKING OVERALLS; WOVEN OR KNITTED UNDERWEAR; WOVEN SKIRTS; WOVEN TOPS; WRISTBANDS; YOGA PANTS; YOGA SHIRTS (U.S. CLS. 22 AND 39).

DAVID YONTEF, EXAMINING ATTORNEY

CLASS 25—(Continued).

SN 85-276,196. NEUVILLE INDUSTRIES, INC., HILDEBRAN, NC. FILED 3-24-2011.

SOCK UNIVERSITY

THE MARK CONSISTS OF STANDARD CHARACTERS WITHOUT CLAIM TO ANY PARTICULAR FONT, STYLE, SIZE, OR COLOR.

NO CLAIM IS MADE TO THE EXCLUSIVE RIGHT TO USE "SOCK", APART FROM THE MARK AS SHOWN.

FOR SOCKS (U.S. CLS. 22 AND 39).

FIRST USE 10-15-1987; IN COMMERCE 10-15-1987.

MAYUR VAGHANI, EXAMINING ATTORNEY

SN 85-276,255. LUKE BURRETT, CAPISTRANO BEACH, CA. FILED 3-24-2011.

PRICELESS

THE MARK CONSISTS OF STANDARD CHARACTERS WITHOUT CLAIM TO ANY PARTICULAR FONT, STYLE, SIZE, OR COLOR.

FOR CLOTHING, NAMELY, TOPS, BOTTOMS, SHIRTS, PANTS, JEANS, SHORTS, SKIRTS, DRESSES, COATS, JACKETS, HEADWEAR, FOOTWEAR, SWEATSHIRTS, SWEATERS, SOCKS, BELTS, PAJAMAS, T-SHIRTS, HATS, OUTERWEAR, UNDERWEAR, VESTS, COVER-UPS, ROBES, TANK-TOPS, PULLOVERS (U.S. CLS. 22 AND 39).

IRA J. GOODSaid, EXAMINING ATTORNEY

SN 85-276,329. THINKIE WINKS, LLC, SOLON, OH. FILED 3-24-2011.



THE MARK CONSISTS THE WORDING "THINKIE WINKS THINK IT! BE IT!" WITH THE DESIGN OF A POLICE BADGE OVER THE FIRST "I" IN "THINKIE", AND OVER THE SECOND "I" IS A DESIGN OF A CUPCAKE WITH FROSTING AND TOPPED WITH A CHERRY. THE "I" IN "WINKS" CONTAINS A STYLIZED HANDLED PAINT BRUSH DIPPED IN PAINT TOPPED OFF WITH A SPLATTER. THE WORDS "THINK IT! BE IT!" ARE IN CAPITAL LETTERS. ALL THE FORE MENTIONED DESCRIPTION IS INSIDE OF A THINK BUBBLE WITH TWO SMALL BUBBLES COMING OUT OF THE BOTTOM AS A TAIL.

FOR TEE SHIRTS (U.S. CLS. 22 AND 39).

SEAN CROWLEY, EXAMINING ATTORNEY

CLASS 25—(Continued).

SN 85-276,330. STASIAK, JAMES, VICTORVILLE, CA. AND STASIAK, KAREN, VICTORVILLE, CA. AND STASIAK, ELIZABETH, VICTORVILLE, CA. FILED 3-24-2011.



THE MARK CONSISTS OF 4 CURVED CORNER SQUARES THAT MAKE A BOX FIGURE WITH 3 OF THE SQUARES SHADED AND "FLOPSIDE OUT" IN STYLIZED FONT WITH THE "P" SHADED.

FOR HATS; JACKETS; SCARFS; SHIRTS; SHOES; SOCKS; SWEATERS (U.S. CLS. 22 AND 39).

APRIL HESIK, EXAMINING ATTORNEY

SN 85-276,481. MEGA CAP INC., RANCHO CUCAMONGA, CA. FILED 3-25-2011.



NO CLAIM IS MADE TO THE EXCLUSIVE RIGHT TO USE "CAP", APART FROM THE MARK AS SHOWN.

THE COLOR(S) BLUE AND RED IS/ARE CLAIMED AS A FEATURE OF THE MARK.

THE MARK CONSISTS OF TWO BLUE-COLORED SLANTING BARS CONNECTED TOGETHER WITH A THIN BLUE LINE AT THE UPPER PORTION AND A LETTER "G" IN RED COLOR ON THE RIGHT SIDE OF THE BARS, WITH THE WORDS "MEGA CAP" IN BLUE UNDERNEATH.

FOR GLOVES; HEADGEAR, NAMELY, BEANIES, BERETS, BONNETS, CAPS, CHULLOS IN THE NATURE OF HATS WITH EARFLAPS, HATS, HEAD BANDS, AND HOODS; KERCHIEFS; SCARFS; SOCKS AND STOCKINGS; SPORTS CAPS AND HATS; VISORS; WEARABLE BLANKETS IN THE NATURE OF BLANKETS WITH SLEEVES; WRIST BANDS (U.S. CLS. 22 AND 39).

FIRST USE 1-1-1998; IN COMMERCE 1-1-1998.

SIMON TENG, EXAMINING ATTORNEY

CLASS 25—(Continued).

SN 85-276,484. MEGA CAP INC., RANCHO CUCAMONGA, CA. FILED 3-25-2011.



THE COLOR(S) BLUE AND RED IS/ARE CLAIMED AS A FEATURE OF THE MARK.

THE MARK CONSISTS OF TWO SLANTING BARS IN BLUE COLOR WITH A THIN BLUE LINE CONNECTING EACH OTHER AT THE UPPER PORTION OF THE BARS, FOLLOWED BY A STYLIZED LETTER "G" IN RED COLOR ON THE RIGHT SIDE.

FOR GLOVES; HEADGEAR, NAMELY, BEANIES, BERETS, BONNETS, CAPS, CHULLOS IN THE NATURE OF HATS WITH EARFLAPS, HATS, HEAD BANDS, AND HOODS; KERCHIEFS; SCARFS; SOCKS AND STOCKINGS; SPORTS CAPS AND HATS; VISORS; WEARABLE BLANKETS IN THE NATURE OF BLANKETS WITH SLEEVES; WRIST BANDS (U.S. CLS. 22 AND 39).

FIRST USE 1-1-1998; IN COMMERCE 1-1-1998.

SIMON TENG, EXAMINING ATTORNEY

SN 85-276,863. THE DOG PERK CORPORATION, MINNEAPOLIS, MN. FILED 3-25-2011.

FunDog Bandanas

THE MARK CONSISTS OF STANDARD CHARACTERS WITHOUT CLAIM TO ANY PARTICULAR FONT, STYLE, SIZE, OR COLOR.

NO CLAIM IS MADE TO THE EXCLUSIVE RIGHT TO USE "BANDANAS", APART FROM THE MARK AS SHOWN.

FOR BANDANAS (U.S. CLS. 22 AND 39).

FIRST USE 1-15-2010; IN COMMERCE 1-15-2010.

JEFFERY COWARD, EXAMINING ATTORNEY

CLASS 25—(Continued).

SN 85-276,948. ANGEL DEAR, UNION CITY, CA. FILED 3-25-2011.

ANGEL GIRL

THE MARK CONSISTS OF STANDARD CHARACTERS WITHOUT CLAIM TO ANY PARTICULAR FONT, STYLE, SIZE, OR COLOR.

FOR CHILDREN'S CLOTHING, NAMELY, SHIRTS, PANTS, JUMPERS, HATS, COVERALLS, SLEEPWEAR, OVERALLS, BOOTIES, SWEATERS, DRESSES, LAYETTES, LEGGINGS (U.S. CLS. 22 AND 39).

CHRISTOPHER BUONGIORNO, EXAMINING ATTORNEY

SN 85-277,187. CAPSMITH, INC., SANFORD, FL. FILED 3-25-2011.



NO CLAIM IS MADE TO THE EXCLUSIVE RIGHT TO USE "CAPS", APART FROM THE MARK AS SHOWN.

THE MARK CONSISTS OF THE STYLIZED WORD "CRITTER" WITH A FURRY APPEARANCE AND CARTOON EARS ON THE LETTER "C" AND A TAIL EXTENDING FROM THE LETTER "R" THAT SWOOPS DOWNWARD UNDER THE WORD "CAPS" AND EXTENDS TO THE LEFT SIDE OF THE DESIGN, ENDING IN A CIRCLE UNDER THE LETTER "C". THE TERM "CAPS" APPEARS IN SMALL FONT UNDER THE LETTERS "ER" IN "CRITTER".

FOR HEADWEAR (U.S. CLS. 22 AND 39).
MARLENE BELL, EXAMINING ATTORNEY

SN 85-277,521. GROENING, MATT, LOS ANGELES, CA. FILED 3-25-2011.

THE CURIOSITY COMPANY

THE MARK CONSISTS OF STANDARD CHARACTERS WITHOUT CLAIM TO ANY PARTICULAR FONT, STYLE, SIZE, OR COLOR.

NO CLAIM IS MADE TO THE EXCLUSIVE RIGHT TO USE "COMPANY", APART FROM THE MARK AS SHOWN.

FOR CLOTHING, NAMELY, T-SHIRTS, SWEATSHIRTS, PANTS, SHORTS, JACKETS, BOOTS, BEACHWEAR, CLOTHING BELTS, BATHING CAPS, CLOTH BIBS, COATS, GLOVES, HATS, PAJAMAS, SHIRTS, SHOES, SOCKS, SUN VISORS, SWIMSUITS AND UNDERGARMENTS (U.S. CLS. 22 AND 39).

HEATHER SAPP, EXAMINING ATTORNEY

CLASS 25—(Continued).

SN 85-277,688. SKIP CHANDLER, BAKERSFIELD, CA. FILED 3-25-2011.

Dik Gear

THE MARK CONSISTS OF STANDARD CHARACTERS WITHOUT CLAIM TO ANY PARTICULAR FONT, STYLE, SIZE, OR COLOR.

NO CLAIM IS MADE TO THE EXCLUSIVE RIGHT TO USE "GEAR", APART FROM THE MARK AS SHOWN.

FOR HATS; HOODED SWEAT SHIRTS; HOODED SWEATSHIRTS; JACKETS; PANTS; SHORT-SLEEVED OR LONG-SLEEVED T-SHIRTS; SHORTS; SOCKS; SWEAT SHIRTS; SWEATSHIRTS; T-SHIRTS; TANK TOPS; TANK-TOPS; UNDERWEAR (U.S. CLS. 22 AND 39).

HEATHER THOMPSON, EXAMINING ATTORNEY

SN 85-277,692. EDISON, JENNIFER L, NOVI, MI. FILED 3-25-2011.

STRAPables

THE MARK CONSISTS OF STANDARD CHARACTERS WITHOUT CLAIM TO ANY PARTICULAR FONT, STYLE, SIZE, OR COLOR.

FOR REMOVABLE STRAPS THAT ATTACH TO CLOTHING, TOPS, DRESSES, BRAS AND SWIMSUITS (U.S. CLS. 22 AND 39).

HEATHER THOMPSON, EXAMINING ATTORNEY

SN 85-277,867. T.R.B. SERVICES LLC, GLENDALE, AZ. FILED 3-26-2011.



THE MARK CONSISTS OF A CHRISTIAN "CROSS" BELOW THE ARCHED TEXT "LOYAL TO ONE".

FOR BELTS; HATS; JACKETS; T-SHIRTS (U.S. CLS. 22 AND 39).

GISELLE AGOSTO, EXAMINING ATTORNEY

CLASS 25—(Continued).

SN 85-277,873. CASTILLO, FERNANDO, HUNTINGTON PARK, CA. FILED 3-26-2011.



THE MARK CONSISTS OF AN OVAL SHAPE WITH WINGS CONTAINING A SKELETON WEARING A HAT, HOLDING A MATCH AND CIGAR, AND A BROKEN TIMER IS ON THE BOTTOM OF THE OVAL. BELOW THAT IS THE WORDING "BUDDHA HEAD SQUAD" IN STYLIZED CHARACTERS.

FOR JACKETS; PANTS; SHIRTS; SHOES (U.S. CLS. 22 AND 39).

JESSICA A. POWERS, EXAMINING ATTORNEY

CLASS 25—(Continued).

SN 85-279,461. ESPENUSA PRODUCTS OF CALIFORNIA, LLC, ALISO VIEJO, CA. FILED 3-29-2011.

EDGY VISIBILITY

THE MARK CONSISTS OF STANDARD CHARACTERS WITHOUT CLAIM TO ANY PARTICULAR FONT, STYLE, SIZE, OR COLOR.

FOR CLOTHING, NAMELY, SHIRTS, JACKETS, COATS, PANTS, TIGHTS, SOCKS, SKIRTS, SHORTS, T-SHIRTS, SHOES, LEG WARMERS, ARM WARMERS, HATS, TIES, BOOTS, GLOVES, MITTENS, BELTS AND VESTS (U.S. CLS. 22 AND 39).

FIRST USE 3-11-2011; IN COMMERCE 3-11-2011.
NICHOLAS ALTREE, EXAMINING ATTORNEY

SN 85-278,081. BAMBOO BOOBOO, TOMS RIVER, NJ. FILED 3-27-2011.



NO CLAIM IS MADE TO THE EXCLUSIVE RIGHT TO USE "BAMBOO", APART FROM THE MARK AS SHOWN.

THE COLOR(S) YELLOW AND GREEN IS/ARE CLAIMED AS A FEATURE OF THE MARK.

THE MARK CONSISTS OF THE WORDS "BAMBOO BOOBOO". THE WORD "BAMBOO" IS YELLOW. THE WORD "BOOBOO" IS LIGHT GREEN. THERE ARE THREE GREEN BAMBOO STALKS WITH LEAVES BEHIND THE WORDS.

FOR INFANT AND TODDLER ONE PIECE CLOTHING; SWEATSHIRTS FOR MEN, WOMEN AND CHILDREN; T-SHIRTS FOR MEN, WOMEN AND CHILDREN, ALL OF THE FOREGOING MADE IN SIGNIFICANT PART OF BAMBOO (U.S. CLS. 22 AND 39).

FIRST USE 1-20-2011; IN COMMERCE 3-15-2011.
JILL PRATER, EXAMINING ATTORNEY

SN 85-279,627. WRIGHT JR., WILLIAM HOWARD, DETROIT, MI. FILED 3-29-2011.

Bwilly Bwightt 1974

THE MARK CONSISTS OF STANDARD CHARACTERS WITHOUT CLAIM TO ANY PARTICULAR FONT, STYLE, SIZE, OR COLOR.

NO CLAIM IS MADE TO THE EXCLUSIVE RIGHT TO USE "1974", APART FROM THE MARK AS SHOWN.

THE NAME "BWILLY BWIGHTT" IDENTIFIES A LIVING INDIVIDUAL WHOSE CONSENT IS OF RECORD. FOR TEE SHIRTS (U.S. CLS. 22 AND 39).

JENNIFER MARTIN, EXAMINING ATTORNEY

CLASS 25—(Continued).

SN 85-280,536. SKIP CHANDLER, BAKERSFIELD, CA. FILED 3-29-2011.



NO CLAIM IS MADE TO THE EXCLUSIVE RIGHT TO USE "GEAR", APART FROM THE MARK AS SHOWN.

THE MARK CONSISTS OF A DESIGN THAT DEPICTS A SUN SETTING, DIRECTLY BELOW THE SUN SETTING ARE THE CHARACTERS "DG" IN STYLIZED FONT AND INTERSECTING, DIRECTLY BELOW THE CHARACTERS "DG" ARE THE CHARACTERS "DIK GEAR" IN STYLIZED FONT.

FOR HATS; HOODED SWEAT SHIRTS; HOODED SWEATSHIRTS; JACKETS; PANTS; SHORT-SLEEVED OR LONG-SLEEVED T-SHIRTS; SHORTS; SOCKS; SWEAT SHIRTS; SWEATSHIRTS; T-SHIRTS; TANK TOPS; TANK-TOPS; UNDERWEAR (U.S. CLS. 22 AND 39).

HEATHER THOMPSON, EXAMINING ATTORNEY

CLASS 25—(Continued).

SN 85-284,810. FORESIDE, CARL, DBA LAST GLADIATOR, MAYWOOD, IL. FILED 4-3-2011.



THE MARK CONSISTS OF "LAST GLADIATOR", OCTAGON ARENA (BIRDS EYE VIEW), SWORD, BALL SHAPED Mallet WITH SPIKES.

FOR ATHLETIC APPAREL, NAMELY, SHIRTS, PANTS, JACKETS, FOOTWEAR, HATS AND CAPS, ATHLETIC UNIFORMS (U.S. CLS. 22 AND 39).

TEJBIR SINGH, EXAMINING ATTORNEY

SN 85-282,332. MELANY BARTHOLOW, DALLAS, TX. FILED 3-31-2011.

Kids Karma

THE MARK CONSISTS OF STANDARD CHARACTERS WITHOUT CLAIM TO ANY PARTICULAR FONT, STYLE, SIZE, OR COLOR.

NO CLAIM IS MADE TO THE EXCLUSIVE RIGHT TO USE "KIDS", APART FROM THE MARK AS SHOWN.

FOR HATS; PANTS; SHORT-SLEEVED OR LONG-SLEEVED T-SHIRTS; SHORTS; T-SHIRTS; TENNIS DRESSES; TENNIS SHOES; TENNIS WEAR (U.S. CLS. 22 AND 39).

AMY KERTGATE, EXAMINING ATTORNEY

SN 85-287,473. HAUGHTON ANGELA MARIE, DBA DEVORI, BRONX, NY. FILED 4-6-2011.



THE MARK CONSISTS OF THE WORDING "DE VORI" WHEREIN THE LETTER "I" IS DEPICTED AS A MICROPHONE.

THE WORDING "DE VORI" HAS NO MEANING IN A FOREIGN LANGUAGE.

FOR POLO SHIRTS; T-SHIRTS FOR BABIES, KIDS, ADULTS, MEN, WOMEN; TEE SHIRTS (U.S. CLS. 22 AND 39).

MELISSA VALLILLO, EXAMINING ATTORNEY

CLASS 25—(Continued).

SN 85-287,512. SISCO TEXTILES N.V., WILLEMSTAD, CURAÇAO, NETHERLANDS ANTILLES, FILED 4-6-2011.

HYPERFREAK

THE MARK CONSISTS OF STANDARD CHARACTERS WITHOUT CLAIM TO ANY PARTICULAR FONT, STYLE, SIZE, OR COLOR.

OWNER OF U.S. REG. NOS. 3,128,634 AND 3,921,762. FOR CLOTHING, NAMELY, SWIMWEAR, BOARD SHORTS, T-SHIRTS AND JACKETS (U.S. CLS. 22 AND 39).

FIRST USE 3-13-2009; IN COMMERCE 3-13-2009. THOMAS MANOR, EXAMINING ATTORNEY

CLASS 25—(Continued).

SN 85-289,013. LIVE NATION WORLDWIDE, INC., BEVERLY HILLS, CA. FILED 4-7-2011.

ELECTRONIC NATION

THE MARK CONSISTS OF STANDARD CHARACTERS WITHOUT CLAIM TO ANY PARTICULAR FONT, STYLE, SIZE, OR COLOR.

FOR CLOTHING, NAMELY, SHIRTS, SWEATSHIRTS, PANTS, JACKETS, HATS AND CAPS (U.S. CLS. 22 AND 39).

DAVID HOFFMAN, EXAMINING ATTORNEY

SN 85-288,494. ETERNAL GOSPEL, WALLA WALLA, WA. FILED 4-7-2011.

EYEKILL

THE MARK CONSISTS OF STANDARD CHARACTERS WITHOUT CLAIM TO ANY PARTICULAR FONT, STYLE, SIZE, OR COLOR.

FOR CLOTHING; NAMELY T-SHIRTS (U.S. CLS. 22 AND 39).

STEVEN R. FINE, EXAMINING ATTORNEY

SN 85-289,025. D & A IND., BEVERLY HILLS, CA. FILED 4-7-2011.

RETRO DOLL

THE MARK CONSISTS OF STANDARD CHARACTERS WITHOUT CLAIM TO ANY PARTICULAR FONT, STYLE, SIZE, OR COLOR.

FOR COATS; DRESSES; JACKETS; PANTS; SKIRTS; TOPS (U.S. CLS. 22 AND 39).

FIRST USE 1-1-2008; IN COMMERCE 1-1-2008. COLLEEN DOMBROW, EXAMINING ATTORNEY

SN 85-288,772. UNION FASHION, LTD., DBA STARR WESTERN WEAR, EL PASO, TX. FILED 4-7-2011.

STARR

THE MARK CONSISTS OF STANDARD CHARACTERS WITHOUT CLAIM TO ANY PARTICULAR FONT, STYLE, SIZE, OR COLOR.

OWNER OF U.S. REG. NO. 2,996,865. SEC. 2(F). FOR CAPS; JACKETS; JEANS; LONG-SLEEVED SHIRTS; POLO SHIRTS; SHORT-SLEEVED SHIRTS; T-SHIRTS (U.S. CLS. 22 AND 39).

FIRST USE 8-1-0991; IN COMMERCE 8-1-1991. TINA MAI, EXAMINING ATTORNEY

SN 85-289,796. JACKSON, CHRISTINE, FAR ROCKAWAY, NY. FILED 4-8-2011.

WADDLE VAMPIRE

THE MARK CONSISTS OF STANDARD CHARACTERS WITHOUT CLAIM TO ANY PARTICULAR FONT, STYLE, SIZE, OR COLOR.

FOR CLOTHING, NAMELY, T-SHIRTS, HOODED SWEATSHIRTS, HATS (U.S. CLS. 22 AND 39).

GENE MACIOL, EXAMINING ATTORNEY

CLASS 25—(Continued).

SN 85-290,624. MOORER, LEONARDO, PFLUGERVILLE, TX. FILED 4-8-2011.



THE MARK CONSISTS OF A SMILE WITH SPARKLE AND THE STYLIZED TEXT "TEEZUR".
FOR CAPS; HATS; PANTS; SHOES; SOCKS; T-SHIRTS; UNDERWEAR (U.S. CLS. 22 AND 39).
FIRST USE 1-1-2000; IN COMMERCE 2-1-2002.
JENNY PARK, EXAMINING ATTORNEY

SN 85-290,825. MAHONEY, MICHELLE, JOI, BROOKLYN, NY. FILED 4-8-2011.

Durati

THE MARK CONSISTS OF STANDARD CHARACTERS WITHOUT CLAIM TO ANY PARTICULAR FONT, STYLE, SIZE, OR COLOR.

FOR BOTTOMS; COATS FOR MEN AND WOMEN; FOOTWEAR FOR MEN; FOOTWEAR FOR MEN AND WOMEN; JACKETS; MEN'S AND WOMEN'S JACKETS, COATS, TROUSERS, VESTS; MEN'S SUITS; MEN'S SUITS, WOMEN'S SUITS; MEN'S UNDERWEAR; SWEATSHIRTS FOR MEN, WOMEN, AND CHILDREN; T-SHIRTS FOR MEN, WOMEN, AND CHILDREN; TOPS; WEARABLE GARMENTS AND CLOTHING, NAMELY, SHIRTS; WOMEN'S CLOTHING, NAMELY, SHIRTS, DRESSES, SKIRTS, BLOUSES (U.S. CLS. 22 AND 39).

MICHAEL ENGEL, EXAMINING ATTORNEY

SN 85-290,917. PERRY, SCOTT, LONG BEACH, CA. FILED 4-9-2011.

Steady Mobbin'

THE MARK CONSISTS OF STANDARD CHARACTERS WITHOUT CLAIM TO ANY PARTICULAR FONT, STYLE, SIZE, OR COLOR.

FOR T-SHIRTS (U.S. CLS. 22 AND 39).

JAMES A. RAUEN, EXAMINING ATTORNEY

CLASS 25—(Continued).

SN 85-290,921. RAMSAY, ELIZABETH, JACKSONVILLE, FL. FILED 4-9-2011.

BLOSSOMING SECRETS

THE MARK CONSISTS OF STANDARD CHARACTERS WITHOUT CLAIM TO ANY PARTICULAR FONT, STYLE, SIZE, OR COLOR.

FOR CLOTHING, NAMELY, TOPS, BOTTOMS, SHIRTS, T-SHIRTS, PANTS, FOOTWEAR, HEADWEAR, UNDERWEAR, SLEEPWEAR, BEACHWEAR, LOUNGEWEAR, NECKWEAR, RAIN WEAR, SWIM WEAR (U.S. CLS. 22 AND 39).

JAMES A. RAUEN, EXAMINING ATTORNEY

SN 85-291,048. HERBERT, DIANA, MALIBU, CA. FILED 4-9-2011.

Maison De Diana

THE MARK CONSISTS OF STANDARD CHARACTERS WITHOUT CLAIM TO ANY PARTICULAR FONT, STYLE, SIZE, OR COLOR.

THE ENGLISH TRANSLATION OF "MAISON DE" IN THE MARK IS "HOUSE OF".

FOR DRESSES; SWEATERS; TOPS (U.S. CLS. 22 AND 39).

MICHAEL KEATING, EXAMINING ATTORNEY

SN 85-291,050. VELA, RAUL, SAN ANTONIO, TX. FILED 4-9-2011.

Keep San Marcos Cooler Than Austin

THE MARK CONSISTS OF STANDARD CHARACTERS WITHOUT CLAIM TO ANY PARTICULAR FONT, STYLE, SIZE, OR COLOR.

FOR CLOTHING, NAMELY, SHORT-SLEEVED T-SHIRTS, 3/4-SLEEVED T-SHIRTS, SLEEVELESS T-SHIRTS, HATS, AND SWEATSHIRTS (U.S. CLS. 22 AND 39).

JOHN HWANG, EXAMINING ATTORNEY

CLASS 25—(Continued).

SN 85-291,113. JONATHAN M. FIELDS, AKA J-MATTHEW, CORAL SPRINGS, FL. FILED 4-10-2011.

Eternal Faith

THE MARK CONSISTS OF STANDARD CHARACTERS WITHOUT CLAIM TO ANY PARTICULAR FONT, STYLE, SIZE, OR COLOR.

FOR BELTS; BELTS FOR CLOTHING; BOTTOMS; CLOTHING FOR BABIES, TODDLERS AND CHILDREN, TREATED WITH FIRE AND HEAT RETARDANTS, NAMELY, PAJAMAS, JACKETS, SHIRTS, PANTS, JUMPERS; JACKETS; JERSEYS; LEATHER BELTS; TOPS; WEARABLE GARMENTS AND CLOTHING, NAMELY, SHIRTS; WOMEN'S CLOTHING, NAMELY, SHIRTS, DRESSES, SKIRTS, BLOUSES (U.S. CLS. 22 AND 39).

FIRST USE 10-1-2010; IN COMMERCE 10-5-2010.
EDWARD NELSON, EXAMINING ATTORNEY

SN 85-291,202. ALEX JR., TIMOTHY JOHN, MARINE CITY, MI. FILED 4-10-2011.

Bro-Pilot

THE MARK CONSISTS OF STANDARD CHARACTERS WITHOUT CLAIM TO ANY PARTICULAR FONT, STYLE, SIZE, OR COLOR.

FOR T-SHIRTS (U.S. CLS. 22 AND 39).
FONG HSU, EXAMINING ATTORNEY

SN 85-291,237. DEGANI DESIGNS, LLC, DBA CHOOZE, DALLAS, TX. FILED 4-10-2011.

chooze shoes

THE MARK CONSISTS OF STANDARD CHARACTERS WITHOUT CLAIM TO ANY PARTICULAR FONT, STYLE, SIZE, OR COLOR.

NO CLAIM IS MADE TO THE EXCLUSIVE RIGHT TO USE "SHOES", APART FROM THE MARK AS SHOWN.
FOR SHOES (U.S. CLS. 22 AND 39).
JAMES A. RAUEN, EXAMINING ATTORNEY

CLASS 25—(Continued).

SN 85-291,284. LEHLA FREELANCE SERVICES, LLC, DBA LEHLA SHOP, BOSSIER CITY, LA. FILED 4-11-2011.

Magneblooms

THE MARK CONSISTS OF STANDARD CHARACTERS WITHOUT CLAIM TO ANY PARTICULAR FONT, STYLE, SIZE, OR COLOR.

FOR HEADBANDS; HEADBANDS FOR CLOTHING (U.S. CLS. 22 AND 39).

FIRST USE 4-1-2011; IN COMMERCE 4-1-2011.

TIMOTHY FINNEGAN, EXAMINING ATTORNEY

SN 85-291,338. HARD NINETY, INC., GILROY, CA. FILED 4-11-2011.



THE MARK CONSISTS OF THE STYLIZED WORDING "HARD NINETY" BENEATH A DESIGN OF THREE VERTICAL CURVED LINES CONNECTED BY AN ANGLED LINE. THE VERTICAL CURVED LINE ON THE FAR RIGHT CONTAINS A STAR.

FOR SPORTS APPAREL AND GARMENTS, NAMELY T-SHIRTS, SWEATSHIRTS, SHORTS AND TANK TOPS (U.S. CLS. 22 AND 39).

FIRST USE 12-19-2010; IN COMMERCE 12-19-2010.
GEOFFREY FOSDICK, EXAMINING ATTORNEY

SN 85-291,342. HARD NINETY, INC., GILROY, CA. FILED 4-11-2011.

DEDICATION HEART AND SOUL

THE MARK CONSISTS OF STANDARD CHARACTERS WITHOUT CLAIM TO ANY PARTICULAR FONT, STYLE, SIZE, OR COLOR.

FOR SPORTS APPAREL AND GARMENTS, NAMELY, T-SHIRTS, SWEATSHIRTS, SHORTS AND TANK TOPS (U.S. CLS. 22 AND 39).

GEOFFREY FOSDICK, EXAMINING ATTORNEY

CLASS 25—(Continued).

SN 85-291,355. SALT LIFE HOLDINGS, LLC, JACKSONVILLE, FL. FILED 4-11-2011.

LIVE THE SALT LIFE

THE MARK CONSISTS OF STANDARD CHARACTERS WITHOUT CLAIM TO ANY PARTICULAR FONT, STYLE, SIZE, OR COLOR.

OWNER OF U.S. REG. NOS. 2,959,429, 3,762,960 AND OTHERS.

FOR MEN'S, WOMEN'S, CHILDREN'S, TODDLER'S, AND INFANT'S CLOTHING AND APPAREL, NAMELY, CAPS, SHIRTS, T-SHIRTS, UNDERWEAR, SOCKS, PANTS, SWEATERS, JACKETS, SHOES, SANDALS, BATHING SUITS, BERMUDA SHORTS, SHORTS, GLOVES, WET SUITS, SWIM TRUNKS, HATS, CAPS WITH VISORS, VISORS, FLEECE PULLOVERS, SWEAT SHIRTS, SURF WEAR, BRIEFS, BOXER BRIEFS, PANTIES, WIND RESISTANT JACKETS AND PANTS; ATHLETIC APPAREL, NAMELY, SHIRTS, PANTS, JACKETS, FOOTWEAR, HATS, CAPS AND ATHLETIC UNIFORMS; INFANT AND TODDLER ONE PIECE CLOTHING; SUN SLEEVES (U.S. CLS. 22 AND 39).

JORDAN BAKER, EXAMINING ATTORNEY

SN 85-291,377. EVIDENSE, INC, BOYNTON BEACH, FL. FILED 4-11-2011.



THE MARK CONSISTS OF THE WORD "EVIDENSE" IN A SPECIFIC GRAFFITI FONT ABOVE THE THUMBPRINT IMAGE.

FOR ATHLETIC APPAREL, NAMELY, SHIRTS, PANTS, JACKETS, FOOTWEAR, HATS AND CAPS, ATHLETIC UNIFORMS (U.S. CLS. 22 AND 39).

FIRST USE 1-1-2001; IN COMMERCE 4-20-2006.
EMILY CARLSEN, EXAMINING ATTORNEY

CLASS 25—(Continued).

SN 85-291,414. ACACIA SWIMWEAR, KULA, HI. FILED 4-11-2011.

ACACIA

THE MARK CONSISTS OF STANDARD CHARACTERS WITHOUT CLAIM TO ANY PARTICULAR FONT, STYLE, SIZE, OR COLOR.

FOR SWIMWEAR (U.S. CLS. 22 AND 39).
FIRST USE 3-31-2010; IN COMMERCE 3-31-2010.
FRANK LATTUCA, EXAMINING ATTORNEY

SN 85-291,633. KAYSER-ROTH CORPORATION, GREENSBORO, NC. FILED 4-11-2011.



OWNER OF U.S. REG. NOS. 1,639,830 AND 3,647,553.
THE MARK CONSISTS OF WORDS "THE GREEN SEAM MEANS MORE SOCK FOR THE MONEY" INSIDE A POLYGON WITH SEAM DESIGN.

FOR CLOTHING, NAMELY, SOCKS (U.S. CLS. 22 AND 39).

FIRST USE 4-1-1997. THE MARK WAS FIRST USED ANYWHERE IN A DIFFERENT FORM OTHER THAN THAT SOUGHT TO BE REGISTERED AT LEAST AS EARLY AS 06/01/1990.; IN COMMERCE 4-1-1997, THE MARK WAS FIRST USED IN COMMERCE IN A DIFFERENT FORM OTHER THAN THAT SOUGHT TO BE REGISTERED AT LEAST AS EARLY AS 06/01/1990..

ANDREW LEASER, EXAMINING ATTORNEY

SN 85-291,748. VZYCO VSS BRAND,LLC, MISSOURI CITY, TX. FILED 4-11-2011.



THE MARK CONSISTS OF THE STYLIZED TEXT "VZYCO" WITH A LINE ON TOP OF THE LETTER "O".

FOR JACKETS; PANTS; SHIRTS; SHOES (U.S. CLS. 22 AND 39).

FIRST USE 1-1-2007; IN COMMERCE 1-1-2007.
RAMONA ORTIGA, EXAMINING ATTORNEY

CLASS 25—(Continued).

SN 85-291,789. CASANELLAS SOLER, SANTIAGO, BARCELONA, SPAIN, AND GÜELL CAMPRUBÍ, RAMÓN, BARCELONA, SPAIN, FILED 4-11-2011.



OWNER OF SPAIN REG. NO. 2.908.328, DATED 5-18-2010, EXPIRES 1-13-2020.

THE MARK CONSISTS OF THE WORD REFERENDUM IN STYLIZED LETTERS.

FOR BATHROBES; BELTS; BIBS NOT OF PAPER; BRASSIERES; CAPS; COATS; DRESSES; FOOTWEAR; GLOVES; HATS; JACKETS; JERSEYS; LAYETTES; LEATHER BELTS; LEATHER BOOTS; LEATHER COATS; LEATHER HATS; LEATHER HEADWEAR; LEATHER JACKETS; LEATHER PANTS; LEATHER SHIRTS; LEATHER SHOES; LEATHER SKIRTS; LEATHER SLIPPERS; LEATHER VESTS; NECKTIES; PAJAMAS; PANTS; RAINCOATS; SCARFS; SHIRTS; SKIRTS; SOCKS; SUITS OF LEATHER; SWEATERS; SWIMMING COSTUMES; T-SHIRTS; TROUSERS OF LEATHER; UNDERWEAR; UNIFORMS (U.S. CLS. 22 AND 39).

ROSELLE HERRERA, EXAMINING ATTORNEY

SN 85-291,849. BARNEY'S, INC., NEW YORK, NY. FILED 4-12-2011.



THE MARK CONSISTS OF STANDARD CHARACTERS WITHOUT CLAIM TO ANY PARTICULAR FONT, STYLE, SIZE, OR COLOR.

FOR ATHLETIC UNIFORMS; BELTS; BANDANAS; BATHING CAPS; BATHING SUITS; BATHROBES; BEACHWEAR; BODY SUITS; BOOTS; BOW TIES; CAPS; COATS; DRESSES; EAR MUFFS; GLOVES; GARTER BELTS; GYM SUITS; HATS; HEADBANDS; HEADWEAR; HOODS; HOSIERY; JACKETS; JEANS; JUMPSUITS; KERCHIEFS; LEGGINGS; LEOTARDS; LINGERIE; MONEY BELTS; MITTENS; NECKTIES; OVERALLS; PAJAMAS; PANTS; PARKAS; ROBES; SCARVES; SHIRTS; SHOES; SHORTS; SKIRTS; SLEEPWEAR; SLIPS; SOCKS; SPORT SHIRTS; SWEATERS; SWEAT BANDS; SWEAT PANTS; SWEAT SHIRTS; SWEAT SHORTS; SUITS; SWIMSUITS; T-SHIRTS; TANK TOPS; TIES; TOPS; TRACKSUITS; TUXEDOS; UNDERSHIRTS; UNDERWEAR; VESTS; VISORS; WRIST BANDS (U.S. CLS. 22 AND 39).

MATTHEW EINSTEIN, EXAMINING ATTORNEY

CLASS 25—(Continued).

SN 85-291,870. THE BOARD OF REGENTS OF THE UNIVERSITY OF NEBRASKA, LINCOLN, NE. FILED 4-11-2011.



THE MARK CONSISTS OF A STYLIZED RENDERING OF THE LETTER O.

FOR CLOTHING, NAMELY SHIRTS, T-SHIRTS, SWEAT SHIRTS, JACKETS AND CAPS (U.S. CLS. 22 AND 39).

FIRST USE 4-1-2010; IN COMMERCE 4-1-2010.

ELIZABETH HUGHITT, EXAMINING ATTORNEY

SN 85-291,882. WEST PLANET GROUP, TAMPA, FL. FILED 4-11-2011.



THE MARK CONSISTS OF STANDARD CHARACTERS WITHOUT CLAIM TO ANY PARTICULAR FONT, STYLE, SIZE, OR COLOR.

FOR DRESS SHIRTS; HATS; HOODED SWEATSHIRTS FOR WOMEN (U.S. CLS. 22 AND 39).

FIRST USE 2-11-2010; IN COMMERCE 2-11-2010.

BRENDAN MCCAULEY, EXAMINING ATTORNEY

SN 85-291,907. REVISE CLOTHING, INC., TETERBORO, NJ. FILED 4-11-2011.



THE MARK CONSISTS OF STANDARD CHARACTERS WITHOUT CLAIM TO ANY PARTICULAR FONT, STYLE, SIZE, OR COLOR.

OWNER OF U.S. REG. NO. 2,762,901.

FOR CLOTHING, NAMELY, CAPRIS, DENIMS, JACKETS, JEANS, PANTS, SHORTS, SKIRTS, AND TOPS FOR WOMEN, MISSES AND JUNIORS (U.S. CLS. 22 AND 39).

ELIZABETH HUGHITT, EXAMINING ATTORNEY

CLASS 25—(Continued).

SN 85-291,993. SKELLERUP INDUSTRIES LIMITED, CHRISTCHURCH, NEW ZEALAND, FILED 4-11-2011.

AQUA TERRA

THE MARK CONSISTS OF STANDARD CHARACTERS WITHOUT CLAIM TO ANY PARTICULAR FONT, STYLE, SIZE, OR COLOR.

FOR BOOTS; FOOTWEAR, NAMELY, WORK BOOTS; WATER PROOF BOOTS; WORK SHOES AND BOOTS (U.S. CLS. 22 AND 39).

FIRST USE 4-1-2011; IN COMMERCE 4-1-2011.
ALEX KEAM, EXAMINING ATTORNEY

SN 85-292,153. COUP CLOTHING, LLC, BOISE, ID. FILED 4-11-2011.

COUP

THE MARK CONSISTS OF STANDARD CHARACTERS WITHOUT CLAIM TO ANY PARTICULAR FONT, STYLE, SIZE, OR COLOR.

FOR BEANIES; BELTS; CAPS; COATS; GLOVES; HATS; PANTS; SCARFS; SHIRTS; SHOES; SHORTS; SOCKS; SWEATSHIRTS; T-SHIRTS (U.S. CLS. 22 AND 39).

FIRST USE 10-17-2009; IN COMMERCE 10-17-2009.
MARK SHINER, EXAMINING ATTORNEY

SN 85-292,286. C TRIMMING USA INC., EL MONTE, CA. FILED 4-11-2011.

Balladusa

THE MARK CONSISTS OF STANDARD CHARACTERS WITHOUT CLAIM TO ANY PARTICULAR FONT, STYLE, SIZE, OR COLOR.

FOR KNIT TOPS; SWEATERS (U.S. CLS. 22 AND 39).
MORGAN WYNNE, EXAMINING ATTORNEY

CLASS 25—(Continued).

SN 85-292,300. JONES, LUIS, JONESBORO, GA. AND CLIFTON, JUAN, JONESBORO, GA. AND REID, JAMEL, JONESBORO, GA. AND GAY, ANTWAIN, JONESBORO, GA. AND HOLLEY, MAURICE, JONESBORO, GA. FILED 4-11-2011.



THE MARK CONSISTS OF A CAPITAL "S" WITH THE WORD "SWANGK" UNDER IT DIAGONALLY, AND THE "S" HAS SHARP CORNERS ALL THE WAY AROUND.

FOR HATS; JACKETS; PANTS; SHIRTS; SHOES; SOCKS (U.S. CLS. 22 AND 39).

ANNE E. GUSTASON, EXAMINING ATTORNEY

SN 85-292,315. RECKLESS VENTURES, LLC, ANN ARBOR, MI. FILED 4-11-2011.



THE MARK CONSISTS OF A SILHOUETTE OF A WOMAN LAYING ON TOP OF WORD "SIDECHICK" (IN ALL CAPITAL LETTERS), AND "WWW.SIDECHICK.COM" BELOW "SIDECHICK".

FOR PANTS; SHIRTS; SHORTS; SWIM SUITS (U.S. CLS. 22 AND 39).

MARK SPARACINO, EXAMINING ATTORNEY

CLASS 25—(Continued).

SN 85-292,353. OLD TOLEDO BRANDS, INC., NEW YORK, NY. FILED 4-11-2011.

OLD TOLEDO BRANDS ORIGINAL
GYM EQUIPMENT

THE MARK CONSISTS OF STANDARD CHARACTERS WITHOUT CLAIM TO ANY PARTICULAR FONT, STYLE, SIZE, OR COLOR.

NO CLAIM IS MADE TO THE EXCLUSIVE RIGHT TO USE "BRANDS ORIGINAL GYM EQUIPMENT", APART FROM THE MARK AS SHOWN.

FOR JACKETS, SHIRTS, T-SHIRTS, BLOUSES, TOPS, PANTS, BOTTOMS, SKIRTS, CAPS, HATS (U.S. CLS. 22 AND 39).

BRIAN PINO, EXAMINING ATTORNEY

SN 85-292,373. ZHAO, KEMIN, LOS ANGELES, CA. FILED 4-11-2011.

—————

JIUYU

THE MARK CONSISTS OF STANDARD CHARACTERS WITHOUT CLAIM TO ANY PARTICULAR FONT, STYLE, SIZE, OR COLOR.

FOR HOSE (U.S. CLS. 22 AND 39).

FIRST USE 1-1-2011; IN COMMERCE 1-1-2011.

GEORGE LORENZO, EXAMINING ATTORNEY

SN 85-292,377. HYUN MEE KIM, STEVENSON RANCH, CA. FILED 4-12-2011.

—————

HOONOO

THE MARK CONSISTS OF STANDARD CHARACTERS WITHOUT CLAIM TO ANY PARTICULAR FONT, STYLE, SIZE, OR COLOR.

FOR HATS; SHIRTS; SPORTS JACKETS; SWEATSHIRTS (U.S. CLS. 22 AND 39).

APRIL ROACH, EXAMINING ATTORNEY

CLASS 25—(Continued).

SN 85-292,393. DEVIN GRACE, HANA, HI. FILED 4-12-2011.

THE NEW HIGH

THE MARK CONSISTS OF STANDARD CHARACTERS WITHOUT CLAIM TO ANY PARTICULAR FONT, STYLE, SIZE, OR COLOR.

FOR CLOTHING, NAMELY, T-SHIRTS, TANK TOPS, SWEATSHIRTS, JACKETS, SHORTS, PANTS, LEGGINGS, DRESSES, SKIRTS, SOCKS, SLEEPWEAR, UNDERWEAR, FOOTWEAR, NECKWEAR AND HATS (U.S. CLS. 22 AND 39).

CAROLINE WOOD, EXAMINING ATTORNEY

SN 85-292,396. DEVIN GRACE, HANA, HI. FILED 4-12-2011.

—————

MY NEW HIGH

THE MARK CONSISTS OF STANDARD CHARACTERS WITHOUT CLAIM TO ANY PARTICULAR FONT, STYLE, SIZE, OR COLOR.

FOR CLOTHING NAMELY, T-SHIRTS, TANK TOPS, SWEATSHIRTS, JACKETS, SHORTS, PANTS, LEGGINGS, DRESSES, SKIRTS, SOCKS, SLEEPWEAR, UNDERWEAR, FOOTWEAR, NECKWEAR AND HATS (U.S. CLS. 22 AND 39).

CAROLINE WOOD, EXAMINING ATTORNEY

SN 85-292,398. DEVIN GRACE, HANA, HI. FILED 4-12-2011.

—————

THE OLD HIGH

THE MARK CONSISTS OF STANDARD CHARACTERS WITHOUT CLAIM TO ANY PARTICULAR FONT, STYLE, SIZE, OR COLOR.

FOR CLOTHING, NAMELY, T-SHIRTS, TANK TOPS, SWEATSHIRTS, JACKETS, SHORTS, PANTS, LEGGINGS, DRESSES, SKIRTS, SOCKS, SLEEPWEAR, UNDERWEAR, FOOTWEAR, NECKWEAR AND HATS (U.S. CLS. 22 AND 39).

CAROLINE WOOD, EXAMINING ATTORNEY

CLASS 25—(Continued).

SN 85-292,400. DEVIN GRACE, HANA, HI. FILED 4-12-2011.

SOBER THE NEW HIGH

THE MARK CONSISTS OF STANDARD CHARACTERS WITHOUT CLAIM TO ANY PARTICULAR FONT, STYLE, SIZE, OR COLOR.

FOR CLOTHING, NAMELY, T-SHIRTS, TANK TOPS, SWEATSHIRTS, JACKETS, SHORTS, PANTS, LEGGINGS, DRESSES, SKIRTS, SOCKS, SLEEPWEAR, UNDERWEAR, FOOTWEAR, NECKWEAR AND HATS (U.S. CLS. 22 AND 39).

CAROLINE WOOD, EXAMINING ATTORNEY

SN 85-292,402. DEVIN GRACE, HANA, HI. FILED 4-12-2011.

LOVE THE NEW HIGH

THE MARK CONSISTS OF STANDARD CHARACTERS WITHOUT CLAIM TO ANY PARTICULAR FONT, STYLE, SIZE, OR COLOR.

FOR CLOTHING, NAMELY, T-SHIRTS, TANK TOPS, SWEATSHIRTS, JACKETS, SHORTS, PANTS, LEGGINGS, DRESSES, SKIRTS, SOCKS, SLEEPWEAR, UNDERWEAR, FOOTWEAR, NECKWEAR AND HATS (U.S. CLS. 22 AND 39).

CAROLINE WOOD, EXAMINING ATTORNEY

SN 85-292,417. MADISON MARCUS INC., BROOKLYN, NY. FILED 4-12-2011.

CIRI

THE MARK CONSISTS OF STANDARD CHARACTERS WITHOUT CLAIM TO ANY PARTICULAR FONT, STYLE, SIZE, OR COLOR.

FOR CLOTHING, NAMELY, TOPS, BOTTOMS, FOOTWEAR, HEADWEAR, WOMEN'S BLOUSE, DRESSES, JACKETS, SKIRTS, KNITWEAR, NAMELY, KNIT BOTTOMS, KNIT DRESSES, KNIT JACKETS, KNIT SHIRTS, KNIT SKIRTS, KNIT TOPS, KNITTED CAPS, KNITTED UNDERWEAR, KNITTED GLOVES (U.S. CLS. 22 AND 39).

ALLISON HOLTZ, EXAMINING ATTORNEY

CLASS 25—(Continued).

SN 85-292,566. SIMMONS, TERENCE, COUNTRY CLUB HILLS, IL. FILED 4-12-2011.



THE MARK CONSISTS OF THE WORD "FUSHURE" DISPLAYED IN A STYLIZED FONT, LOCATED DIRECTLY UNDERNEATH THE WORD "FUSHURE" ARE THE LETTERS "F","U","J","O","R","E" ENCASED IN BRACKETS. LOCATED DIRECTLY UNDERNEATH "/FU.JORE/" IS THE PHRASE, "IS THE FUTURE", ALSO DISPLAYED IN A STYLIZED FONT AND IMMEDIATELY FOLLOWED BY AN ELLIPSIS.

FOR APPAREL FOR DANCERS, NAMELY, TEE SHIRTS, SWEATSHIRTS, PANTS, LEGGINGS, SHORTS AND JACKETS; APRONS; ATHLETIC APPAREL, NAMELY, SHIRTS, PANTS, JACKETS, FOOTWEAR, HATS AND CAPS, ATHLETIC UNIFORMS, ATHLETIC TIGHTS; BEACHWEAR, NAMELY, BATHING SUITS; BIKINIS; BEACH COVER-UPS, BEACH SHOES, AQUA SHOES, TANKINIS; BATHROBES; BEANIES; BELTS, NAMELY, BELTS MADE OF FABRIC, BELTS MADE FROM IMITATION LEATHER, BELTS MADE OF LEATHER, BELTS THAT ARE DESIGNED TO ACCOMMODATE PREGNANCY SIZE CHANGES; BICYCLING GLOVES; BOARD SHORTS; BALLET SHOES; BALLET SLIPPERS; BLAZERS; BODY SHIRTS; BODY SUITS; BOMBER JACKETS; BRAS; STRAPLESS BRAS; SPORTS BRAS; CAPES; CAPES FOR USE IN SALONS AND BARBER SHOPS; CAPRIS; CARDIGANS; CARGO PANTS; CLOTHING FOR BABIES, TODDLERS, AND CHILDREN TREATED WITH FIRE AND HEAT RETARDANTS, NAMELY, PAJAMAS, SOCKS, JACKETS, SHIRTS, PANTS, AND JUMPERS; CYCLISTS' JERSEYS; CYCLING SHOES; CYCLING SHORTS; DANCE COSTUMES; DANCE SLIPPERS; DANCE SHOES; DO RAGS; EAR BANDS; EAR MUFFS; EAR WARMERS; FINGERLESS GLOVES; GLOVES AND MITTENS; FOOTWEAR; FOUNDATION GARMENTS WORN AROUND THE MIDSECTION OR THIGHS TO KEEP THE STOMACH IN AND CREATE A SLIMMING EFFECT; UNDERWEAR, NAMELY, BRIEFS, PANTIES, THONGS, BOY SHORTS, G-STRINGS, BOXER SHORTS; TANK TOPS, MUSCLE SHIRTS, HOODED PULLOVERS, HOODED SWEAT SHIRTS; DENIM JACKETS, COATS, SHORTS, PANTS, AND SHIRTS; DOWN JACKETS AND SUITS; DRESSES; EVENING DRESSES AND GOWNS; DRESSES THAT MAY ALSO BE USED AS TOWELS; FLEECE PANTS, SHORTS, PULLOVERS, TOPS, AND VESTS; FLIGHT SUITS; FLIP FLOPS; FUR COATS, JACKETS, HATS, MUFFS, AND STOLE; GOLF APPAREL AND FOOTWEAR, NAMELY, SHIRTS, PANTS, SKIRTS, SHORTS, SHOES, CLEATS, SPIKES, HATS, CAPS, AND VISORS; GYM APPAREL, NAMELY, SHORTS, PANTS, GYM SUITS, AND BOOTS; HATS; HATBANDS; HEADWEAR, NAMELY, HEAD SCARVES, HEAD SWEATBANDS, HEADBANDS; INFANT APPAREL, NAMELY, SLEEPERS, WEARABLE BLANKETS, BODYSUITS, LAYETTES, SHIRTS, PANTS, SHOES, AND BOOTS; INSOLES FOR FOOTWEAR; JEGGINGS, NAMELY, PANTS THAT ARE PARTIALLY JEANS AND PARTIALLY LEGGINGS; JEANS; JOGGING SUITS AND PANTS; JUMPERS; JUMP SUITS; KNEE-HIGH STOCKINGS; LEG SHAPERS; LEG WARMERS; LEGGINGS; LEOTARDS AND TIGHTS FOR WOMEN AND CHILDREN OF NYLON, COTTON OR OTHER TEXTILE FIBERS; LIGHT-REFLECTING COATS AND JACKETS; LINGERIE; LINGERIE ACCESSORIES, NAMELY, REMOVABLE SILICONE BREAST ENHANCER PADS USED IN A BRA; LONG JOHN; LONG AND SHORT SLEEVED TEE SHIRTS; LOUNGEWEAR, NAMELY, LOUNGE SHIRTS AND PANTS; LONG AND SHORT SLEEVED POLO SHIRTS; MASQUERADE COSTUMES AND MASKS; MATERNITY APPAREL,

CLASS 25—(Continued).

NAMELY, LEGGINGS FEATURING BUILT-IN MATERNITY BANDS, LINGERIE, BRAS, SHIRTS, PANTS, AND SLEEPWEAR; MOISTURE-WICKING SPORTS SHIRTS, PANTS, AND BRAS; MONEY BELTS; MOTORCYCLE JACKETS, GLOVES, RAIN SUITS, AND BOOTS; NIGHT-GOWNS, NIGHT SHIRTS; NIPPLE COVERS, NAMELY, PASTIES; PAJAMAS; RAINWEAR; SARONGS; SCARVES; SKI AND SNOWBOARDING CLOTHING AND ACCESSORIES, NAMELY, SNOW PANTS, SNOW SUITS, JACKETS, HATS, GLOVES, MASKS, BOOTS, BOOT BAGS, AND BOOT CASES; SLIPPER SOCKS; SUNDRESSES; SURF WEAR; VISORS; WAIST CINCHERS; WETSUITS; WETSUIT GLOVES; WRISTBANDS; WRISTBANDS CONTAINING A COOLING SUBSTANCE TO COOL THE WEARER; YOGA PANTS AND SHIRTS (U.S. CLS. 22 AND 39).

LOURDES AYALA, EXAMINING ATTORNEY

SN 85-292,655. JUNGWIRTH, BRETT, OSHKOSH, WI. AND JUNGWIRTH, BILLIE JO, OSHKOSH, WI. FILED 4-12-2011.



THE MARK CONSISTS OF THE WORDS "ALL IN POKER" ABOVE SIX STACKS OF CASINO-STYLE GAME CHIPS, THE STACKS ENCIRCLED WITH A CHAIN LINK BRACELET HAVING THE WORD "CHAMPION" ON IT, AND THE WORDS "WEAR IT LIKE A CHAMPION" BELOW THE STACKS AND BRACELET.

FOR CLOTHING, NAMELY, CAPS AND HATS, BANDANAS, SHORTS, SHIRTS, T-SHIRTS, SWEATSHIRTS, JACKETS, PAJAMAS, PANTS, SKIRTS, DRESSES, SOCKS, UNDERWEAR (U.S. CLS. 22 AND 39).

KATHLEEN M. VANSTON, EXAMINING ATTORNEY

SN 85-292,671. MJEK, LLC, PORTLAND, OR. FILED 4-12-2011.

THE MARK CONSISTS OF THE STYLIZED WORD "MJEK".

FOR JACKETS; PANTS; SHIRTS; SHOES (U.S. CLS. 22 AND 39).

RONALD MCMORROW, EXAMINING ATTORNEY

CLASS 25—(Continued).

SN 85-292,848. DAN LORITZ, GLENDALE, CA. AND GINA TERRONES, GLENDALE, CA. FILED 4-12-2011.

BEAR HUGS

THE MARK CONSISTS OF STANDARD CHARACTERS WITHOUT CLAIM TO ANY PARTICULAR FONT, STYLE, SIZE, OR COLOR.

FOR SHOES (U.S. CLS. 22 AND 39).

JUDITH HELFMAN, EXAMINING ATTORNEY

SN 85-293,078. UTEX CORPORATION, MONT-ROYAL, QUÉBEC, CANADA, FILED 4-12-2011.

TRUE TO ME

THE MARK CONSISTS OF STANDARD CHARACTERS WITHOUT CLAIM TO ANY PARTICULAR FONT, STYLE, SIZE, OR COLOR.

FOR MEN'S AND LADIES' CLOTHING, NAMELY, OUTERWEAR, NAMELY, RAINWEAR, JACKETS AND COATS; SPORTSWEAR, NAMELY, SHIRTS, PANTS, JACKETS, BLAZERS, SPORT COATS, VESTS, DRESSES, SKIRTS AND BLOUSES; SUITS, BLOUSES, SKIRTS, PANTS, SWEATERS, JACKETS, BELTS, AND SOCKS (U.S. CLS. 22 AND 39).

LESLEY LAMOTHE, EXAMINING ATTORNEY

SN 85-293,094. FUNNY MAN DESIGNS, KATY, TX. FILED 4-12-2011.

Lisa and Lynn

THE MARK CONSISTS OF STANDARD CHARACTERS WITHOUT CLAIM TO ANY PARTICULAR FONT, STYLE, SIZE, OR COLOR.

FOR MEN'S AND WOMEN'S JACKETS, COATS, TROUSERS, VESTS (U.S. CLS. 22 AND 39).

FIRST USE 4-12-2011; IN COMMERCE 4-12-2011.

LESLIE RICHARDS, EXAMINING ATTORNEY

CLASS 25—(Continued).

SN 85-293,101. UTEX CORPORATION, MONT-ROYAL, QUÉBEC, CANADA, FILED 4-12-2011.

JUST AS YOU ARE

THE MARK CONSISTS OF STANDARD CHARACTERS WITHOUT CLAIM TO ANY PARTICULAR FONT, STYLE, SIZE, OR COLOR.

FOR MEN'S AND LADIES' PLUS SIZE CLOTHING, NAMELY - PLUS SIZE OUTERWEAR, NAMELY RAINWEAR, JACKETS AND COATS; PLUS SIZE SPORTSWEAR, NAMELY SHIRTS, PANTS, JACKETS, BLAZERS, SPORT COATS, VESTS, DRESSES, SKIRTS AND BLOUSES; PLUS SIZE SUITS, BLOUSES, SKIRTS, PANTS, SWEATERS, JACKETS, BELTS, SOCKS, UNDERWEAR, AND LINGERIE (U.S. CLS. 22 AND 39).

LESLEY LAMOTHE, EXAMINING ATTORNEY

SN 85-293,120. SWIM STRONG FOUNDATION, INC., EAST ELMHURST, NY. FILED 4-12-2011.



THE MARK CONSISTS OF A SINE-WAVE LIKE FORM WITH A CIRCULAR DOT NESTLED IN THE TROUGH OF THE WAVE.

FOR BEACH COVER-UPS; PANTS; SHORTS; SWEAT PANTS; SWEAT SHIRTS; T-SHIRTS (U.S. CLS. 22 AND 39).

LIEF MARTIN, EXAMINING ATTORNEY

SN 85-293,245. THRASHER, BENJAMIN, LONG BEACH, CA. FILED 4-12-2011.

People Are the Reason

THE MARK CONSISTS OF STANDARD CHARACTERS WITHOUT CLAIM TO ANY PARTICULAR FONT, STYLE, SIZE, OR COLOR.

FOR JACKETS; PANTS; SHIRTS (U.S. CLS. 22 AND 39).

DAVID COLLIER, EXAMINING ATTORNEY

CLASS 25—(Continued).

SN 85-293,328. WACHTEL, MICHAEL, RIVERSIDE, CA. FILED 4-12-2011.



THE MARK CONSISTS OF A CIRCLE CONTAINING A LARGE "Y" WITH ARCS ON EACH END OF THE Y AND WITH 3 SEMI CIRCLES IN BETWEEN THE Y LINES. MANY LINES SPREADING FROM AROUND THE CIRCLE ORIGINATING FROM THE CENTER AS A FOCAL POINT. ON TOP OF THE LETTER "Y" THERE IS THE STYLIZED TEXT "GENERATION".

FOR BATHING SUITS; BUTTON DOWN SHIRTS; HATS; HOODED SWEAT SHIRTS; LONG-SLEEVED SHIRTS; POLO SHIRTS; SHORT-SLEEVED OR LONG-SLEEVED T-SHIRTS; SHORTS (U.S. CLS. 22 AND 39).

NAKWAMA ANKRAH, EXAMINING ATTORNEY

SN 85-293,486. BUFFORD, WESLEY, HOUSTON, TX. FILED 4-12-2011.

DMNEE JRMNE

THE MARK CONSISTS OF STANDARD CHARACTERS WITHOUT CLAIM TO ANY PARTICULAR FONT, STYLE, SIZE, OR COLOR.

FOR HATS; JACKETS; PANTS; SHIRTS; SHOES (U.S. CLS. 22 AND 39).

MARK SPARACINO, EXAMINING ATTORNEY

CLASS 25—(Continued).

SN 85-293,504. SIMON, JEROME ANDRE, COVENTON, GA. AND SIMON, LENORE, COVENTON, GA. FILED 4-12-2011.

WASIA J&L SIMON

THE MARK CONSISTS OF STANDARD CHARACTERS WITHOUT CLAIM TO ANY PARTICULAR FONT, STYLE, SIZE, OR COLOR.

THE NAME(S), PORTRAIT(S), AND/OR SIGNATURE(S) SHOWN IN THE MARK IDENTIFIES JEROME ANDRE "SIMON" AND LENORE "SIMON", WHOSE CONSENT(S) TO REGISTER IS MADE OF RECORD.

THE ENGLISH TRANSLATION OF "WASIA" IN THE MARK IS "TESTAMENT".

FOR FOOTWEAR; HEADGEAR, NAMELY, CAPS AND HATS; JEANS; SUITS; T-SHIRTS (U.S. CLS. 22 AND 39). FIRST USE 3-10-2011; IN COMMERCE 3-10-2011. JUDITH HELFMAN, EXAMINING ATTORNEY

SN 85-293,571. ROBERTS, HARRY, TAMPA, FL. FILED 4-13-2011.



THE MARK CONSISTS OF AN IMAGE OF A STICK FIGURE WITH A BOW TIE WITH ITS LEGS COCKED TO THE LEFT WITH ITS HEELS CLICKING TOGETHER. THE ARMS OF THE IMAGE ARE EXTENDED OUT FROM THE BODY. THE IMAGE HAS A FACE WITH AN EXAGGERATED CURLED NOSE, LARGE SMILE AND TWO EYES WITH THE LEFT EYE SLIGHTLY LARGER THAN THE RIGHT EYE. THE FACE FOR THE IMAGE HAS NO OUTLINE. ABOVE THE IMAGE IS WORDING THAT READS, "BE A JOEY". BELOW THE IMAGE IS WORDING THAT READS, "DREAM BIG" AS SHOWN IN THE MARK.

FOR CLOTHING, NAMELY, T-SHIRTS, LONG SLEEVE SHIRTS, SWEAT SHIRTS, HATS, TIES, SLEEPWEAR, CLOTH BIBS; BABY APPAREL, NAMELY, PAMAMAS, JACKETS, SHIRTS, PANTS, JUMPERS, TOPS, BOTTOMS (U.S. CLS. 22 AND 39).

DAVID C. REIHNER, EXAMINING ATTORNEY

CLASS 25—(Continued).

SN 85-293,574. MADISON MARCUS INC., BROOKLYN, NY. FILED 4-13-2011.

TAZIA

THE MARK CONSISTS OF STANDARD CHARACTERS WITHOUT CLAIM TO ANY PARTICULAR FONT, STYLE, SIZE, OR COLOR.

FOR CLOTHING, NAMELY, TOPS, BOTTOMS, FOOTWEAR, HEADWEAR, WOMEN'S BLOUSE, DRESSES, JACKETS, SKIRTS, KNITWEAR, NAMELY, KNIT BOTTOMS, KNIT DRESSES, KNIT JACKETS, KNIT SHIRTS, KNIT SKIRTS, KNIT TOPS, KNITTED CAPS, KNITTED UNDERWEAR, KNITTED GLOVES (U.S. CLS. 22 AND 39).

ALLISON HOLTZ, EXAMINING ATTORNEY

SN 85-293,667. BAREFOOTERS CORP., TORONTO, ONTARIO, CANADA, FILED 4-13-2011.

BAREFOOTERS

THE MARK CONSISTS OF STANDARD CHARACTERS WITHOUT CLAIM TO ANY PARTICULAR FONT, STYLE, SIZE, OR COLOR.

FOR SLIP-RESISTANT BOOTS, SANDALS AND SHOES, T-SHIRTS, HATS (U.S. CLS. 22 AND 39). FONG HSU, EXAMINING ATTORNEY

SN 85-293,695. HARD NINETY, INC., GILROY, CA. FILED 4-13-2011.



THE MARK CONSISTS OF THREE VERTICAL CURVED LINES CONNECTED BY AN ANGLED LINE. THE VERTICAL CURVED LINE ON THE FAR RIGHT CONTAINS A STAR.

FOR SPORTS APPAREL AND GARMENTS, NAMELY, T-SHIRTS, SWEATSHIRTS, SHORTS AND TANK TOPS (U.S. CLS. 22 AND 39).

GEOFFREY FOSDICK, EXAMINING ATTORNEY

CLASS 25—(Continued).

SN 85-293,763. HAODE NEW YORK INC., FRESH MEADOWS, NY. FILED 4-13-2011.



THE COLOR(S) RED, YELLOW, BLACK, LIGHTER RED, AND GREY IS/ARE CLAIMED AS A FEATURE OF THE MARK.

THE MARK CONSISTS OF YELLOW EQUILATERAL TRIANGLE WITH CURVED CORNERS, FRAMED WITH RED OUTLINING. THE TOP LINE OF THE TRIANGLE GOES HORIZONTALLY, AND THE ANGLE OPPOSITE TO THE TOP LINE OF THE TRIANGLE POINTS PERPENDICULARLY DOWNWARDS. ENCLOSED BY THE RED FRAME AND ON THE YELLOW TRIANGLE, THERE ARE TWO STYLIZED UPPER CASE LETTERS "S" AND "F". LETTER "S" IS LOCATED AT THE UPPER LEFT OF THE LETTER "F", AND LETTER "F" IS LOCATED AT THE LOWER RIGHT OF THE LETTER "S". BOTH LETTERS ARE IN RED. LETTER "S" STARTS FROM THE MIDDLE OF THE INNER TOP LINE OF THE RED FRAME, AND ENDS AT TWO FIFTHS OF THE INNER LEFT LINE OF THE RED FRAME. THE LETTER "F" CONNECTS SEPARATELY WITH ONE THIRD, TWO THIRDS, AND SIX SEVENTHS OF THE INNER RIGHT LINE OF THE RED FRAME, AND SIX SEVENTHS OF THE INNER LEFT LINE OF THE RED FRAME. FOR THE OUTER LINES OF THE RED FRAME OF THE TRIANGLE, STARING FROM THE LEFT ANGLE OF THE RED FRAME AND GOES CLOCKWISE, THERE IS A LIGHTER RED SHADE ALONG THE OUTER TOP LINE OF THE RED FRAME, THEN WHEN IT GOES AROUND THE RIGHT ANGLE OF THE RED FRAME, THE COLOR LIGHTER RED CHANGES GRADUALLY TO BLACK, THE RIGHT OUTER LINE OF THE RED FRAME IS BLACK, UNTIL IT REACHES THE ANGLE POINTING PERPENDICULARLY DOWNWARDS THE COLOR BLACK CHANGES GRADUALLY TO GREY, THE LEFT OUTER LINE OF THE RED FRAME IS GREY, UNTIL IT MEETS THE LEFT ANGLE OF THE RED FRAME. FOR THE INNER LINES OF THE RED FRAME OF THE TRIANGLE, STARING FROM THE LEFT ANGLE OF THE RED FRAME AND GOES CLOCKWISE, THERE IS A BLACK SHADE ALONG THE INNER TOP LINE OF THE RED FRAME, THEN WHEN IT GOES AROUND THE RIGHT ANGLE OF THE RED FRAME, THE COLOR BLACK CHANGES GRADUALLY TO LIGHTER RED, THE RIGHT INNER LINE OF THE RED FRAME IS LIGHTER RED, UNTIL IT REACHES THE ANGLE POINTING PERPENDICULARLY DOWNWARDS THE COLOR LIGHTER RED CHANGES GRADUALLY TO GREY, THE LEFT INNER LINE OF THE RED FRAME IS GREY, UNTIL IT MEETS THE LEFT ANGLE OF THE RED FRAME. WHEN THE LETTERS "S" AND "F" CONNECTS WITH THE INNER LINES OF THE RED FRAME OF THE TRIANGLE, NAMELY, FROM ONE THIRD TO ONE HALF OF THE INNER LINE OF THE RED FRAME, TWO FIFTHS AND SIX SEVENTHS OF THE INNER LEFT LINE OF THE RED FRAME, AND ONE THIRD, TWO THIRDS, AND SIX SEVENTHS OF THE INNER RIGHT LINE OF THE RED FRAME, THE CONNECTING AREAS ARE IN RED. THE SHADES ON THE LEFT AND ABOVE OF THE LETTERS "S", EXCEPT FOR THE CONNECTING AREAS BETWEEN THE LETTERS "S" AND THE INNER TOP LINE AND INNER LEFT LINE OF THE RED FRAME, ARE IN LIGHTER RED COLOR. THE SHADES ON THE LEFT AND ABOVE OF THE LETTER "F", EXCEPT FOR THE CONNECTING AREAS BETWEEN THE LETTER "F" AND THE INNER TOP LINE AND INNER LEFT LINE OF THE RED FRAME, ARE IN LIGHTER RED COLOR. THE SHADES ON THE RIGHT

CLASS 25—(Continued).

AND BELOW OF THE LETTERS "S", EXCEPT FOR THE CONNECTING AREAS BETWEEN THE LETTERS "S" AND THE INNER LEFT LINE AND INNER RIGHT LINE OF THE RED FRAME, ARE IN BLACK COLOR. THE SHADES ON THE RIGHT AND BELOW OF THE LETTER "F", EXCEPT FOR THE CONNECTING AREAS BETWEEN THE LETTER "F" AND THE INNER LEFT LINE AND INNER RIGHT LINE OF THE RED FRAME, ARE IN BLACK COLOR. THE SHADES OF THE LETTERS "S" AND "F" CREATES A 3-D EFFECT.

FOR A-SHIRTS; ATHLETIC APPAREL, NAMELY, SHIRTS, PANTS, JACKETS, FOOTWEAR, HATS AND CAPS, ATHLETIC UNIFORMS; ATHLETIC SHOES; BELTS; BLOUSES; BOOTS; CAPS; CLOTHING, NAMELY, NECK TUBES; COATS; COATS FOR MEN AND WOMEN; COATS MADE OF COTTON; DENIMS; DRESS SHIRTS; DRESS SUITS; DRESSES; FOOTWEAR; FUR COATS AND JACKETS; FUR HATS; GLOVES; HATS; HEAD WEAR; JEANS; KNIT BOTTOMS; KNIT JACKETS; KNIT SHIRTS; KNIT SKIRTS; LEATHER JACKETS; LEATHER PANTS; LEATHER SHIRTS; LEG WARMERS; LEGGINGS; NECKERCHIEFS; NECKWEAR; PANTS; POLO SHIRTS; SCARFS; SHIRTS; SHOES; SHORT TROUSERS; SHORTS; SILK SCARVES; SLEEP SHIRTS; SOCKS; SUITS; SWEATERS; SWEATPANTS; SWEATSHIRTS; T-SHIRTS; TEE SHIRTS; TOPS; TROUSERS; UNDERCLOTHES; UNDERPANTS; UNDERSHIRTS; VESTS; WIND-JACKETS; WINDSHIRTS (U.S. CLS. 22 AND 39).

LOURDES AYALA, EXAMINING ATTORNEY

SN 85-293,885. JASON DOLL, MANDAN, ND. FILED 4-13-2011.

TATTOO'D DEVIANT

THE MARK CONSISTS OF STANDARD CHARACTERS WITHOUT CLAIM TO ANY PARTICULAR FONT, STYLE, SIZE, OR COLOR.

FOR HOODED SWEAT SHIRTS; JACKETS; LONG-SLEEVED SHIRTS; OPEN-NECKED SHIRTS; SHIRTS; SHORT-SLEEVED OR LONG-SLEEVED T-SHIRTS; SWEAT SHIRTS (U.S. CLS. 22 AND 39).

JOHN WILKE, EXAMINING ATTORNEY

SN 85-293,895. JASON DOLL, MANDAN, ND. FILED 4-13-2011.

TATTOOED DEVIANT

THE MARK CONSISTS OF STANDARD CHARACTERS WITHOUT CLAIM TO ANY PARTICULAR FONT, STYLE, SIZE, OR COLOR.

FOR HOODED SWEAT SHIRTS; JACKETS; SHIRTS; SHORT-SLEEVED OR LONG-SLEEVED T-SHIRTS; WOMEN'S CLOTHING, NAMELY, SHIRTS, DRESSES, SKIRTS, BLOUSES (U.S. CLS. 22 AND 39).

JOHN WILKE, EXAMINING ATTORNEY

CLASS 25—(Continued).

SN 85-293,946. BOLT, GREG, CLACKAMAS, OR. FILED 4-13-2011.

Let's Get Better

THE MARK CONSISTS OF STANDARD CHARACTERS WITHOUT CLAIM TO ANY PARTICULAR FONT, STYLE, SIZE, OR COLOR.

FOR CLOTHING, NAMELY T-SHIRTS, GOLF-SHIRTS, SWEATSHIRTS, CAPS, AND BASKETBALL UNIFORMS (U.S. CLS. 22 AND 39).

GINA HAYES, EXAMINING ATTORNEY

SN 85-293,973. BOLT, GREG, CLACKAMAS, OR. FILED 4-13-2011.

Getting Better

THE MARK CONSISTS OF STANDARD CHARACTERS WITHOUT CLAIM TO ANY PARTICULAR FONT, STYLE, SIZE, OR COLOR.

FOR CLOTHING, NAMELY T-SHIRTS, GOLF-SHIRTS, SWEATSHIRTS, CAPS, AND BASKETBALL UNIFORMS (U.S. CLS. 22 AND 39).

GINA HAYES, EXAMINING ATTORNEY

SN 85-294,065. BOSWELL, NICHOLAS, OMAHA, NE. FILED 4-13-2011.

NATURAL DOMINATION

THE MARK CONSISTS OF STANDARD CHARACTERS WITHOUT CLAIM TO ANY PARTICULAR FONT, STYLE, SIZE, OR COLOR.

FOR SHORTS; SWEATSHIRTS; T-SHIRTS (U.S. CLS. 22 AND 39).

YAT SYE, LEE, EXAMINING ATTORNEY

CLASS 25—(Continued).

SN 85-294,066. CISNEROS, MARIO, PHOENIX, AZ. AND FIGUEROA, LAURA, PHOENIX, AZ. FILED 4-13-2011.

MY HERO DIED TO SAVE ME,
WHAT HAS YOUR HERO DONE TO
SAVE YOU?

THE MARK CONSISTS OF STANDARD CHARACTERS WITHOUT CLAIM TO ANY PARTICULAR FONT, STYLE, SIZE, OR COLOR.

FOR BOXER SHORTS; BUTTON DOWN SHIRTS; CAPRI PANTS; CAPS; CAPS WITH VISORS; CARGO PANTS; COATS; COLLARED SHIRTS; CROP PANTS; DENIMS; DRESS SHIRTS; GOLF SHIRTS; HATS; HOODED SWEAT SHIRTS; JACKETS; JEANS; JOGGING PANTS; KNIT SHIRTS; LONG-SLEEVED SHIRTS; PANTS; POLO SHIRTS; SHIRTS; SHIRTS AND SHORT-SLEEVED SHIRTS; SHIRTS FOR INFANTS, BABIES, TODDLERS AND CHILDREN; SHORT-SLEEVED SHIRTS; SHORTS; SPORTS PANTS; SPORTS SHIRTS; SWEAT PANTS; SWEAT SHIRTS; SWEAT SHORTS; T-SHIRTS; TRACK PANTS (U.S. CLS. 22 AND 39).

YAT SYE, LEE, EXAMINING ATTORNEY

SN 85-294,097. MILLER-SCHINDLER, FRANCESCA, SAN DIEGO, CA. FILED 4-13-2011.



THE STIPPLING IS FOR SHADING PURPOSES ONLY. THE MARK CONSISTS OF A GENERIC HUMAN SHAPE WITH A QUESTION MARK ALONG THE RIGHT SIDE OF THE FIGURE, THE RIGHT HAND OF THE FIGURE ON ITS CHEST. THE QUESTION MARK APPEARS TO MERGE WITH THE FIGURE'S LEFT ARM RAISED ABOVE ITS HEAD.

FOR SHIRTS (U.S. CLS. 22 AND 39).

LIEF MARTIN, EXAMINING ATTORNEY

CLASS 25—(Continued).

SN 85-294,119. NICKERSON, MATT, RIO RANCHO, NM. FILED 4-13-2011.

CLEAN & SOBER

THE MARK CONSISTS OF STANDARD CHARACTERS WITHOUT CLAIM TO ANY PARTICULAR FONT, STYLE, SIZE, OR COLOR.

FOR BATHING SUITS; BLOUSES; BODY SUITS; BOXER BRIEFS; BOXER SHORTS; BRAS; BRIEFS; BUTTON DOWN SHIRTS; CAMP SHIRTS; CAPRI PANTS; CARGO PANTS; CLOTHING FOR WEAR IN WRESTLING GAMES; CLOTHING, NAMELY, ARM WARMERS; CLOTHING, NAMELY, HAND-WARMERS; CLOTHING, NAMELY, KNEE WARMERS; CLOTHING, NAMELY, NECK TUBES; CLOTHING, NAMELY, WRAP AROUNDS; COATS; COLLARED SHIRTS; CREW NECK SWEATERS; DENIMS; DRESS PANTS; DRESS SHIRTS; DRESS SUITS; DRESSES; DUSTERS; FLIP FLOPS; GOLF PANTS, SHIRTS AND SKIRTS; GOLF SHORTS; GYM PANTS; GYM SHORTS; GYM SUITS; HALTER TOPS; HATS; HEADGEAR, NAMELY, CAPS, BEANIES, HEADBANDS; INFANT AND TODDLER ONE PIECE CLOTHING; JACKETS; JERSEYS; JOGGING PANTS; JOGGING SUITS; JUDO SUITS; KNIT SHIRTS; LEATHER BELTS; LINGERIE; LONG-SLEEVED SHIRTS; MANTLES; MEN'S SUITS; MEN'S SUITS, WOMEN'S SUITS; MUFFLERS; OPEN-NECKED SHIRTS; OVER SHIRTS; PAJAMAS; PANTIES, SHORTS AND BRIEFS; PIQUE SHIRTS; POLO SHIRTS; ROBES; RUGBY TOPS; SHIRTS; SHIRTS AND SHORT-SLEEVED SHIRTS; SHOES; SHORT-SLEEVED OR LONG-SLEEVED T-SHIRTS; SHORTS; SKI PANTS; SKI SUITS; SKIRTS AND DRESSES; SNOW PANTS; SOCKS; SPORT SHIRTS; SPORTS BRA; SPORTS BRAS; SPORTS SHIRTS; SUIT COATS; SUITS; SWEAT PANTS; SWEAT SHIRTS; SWEAT SUITS; SWEATERS; SWIMSUITS; T-SHIRTS; TANK TOPS; TANK-TOPS; TEE SHIRTS; THERMAL UNDERWEAR; THONGS; THONGS; TOP COATS; TOPCOATS; TRACK PANTS; TURTLE NECK SHIRTS; TURTLENECK SWEATERS; V-NECK SWEATERS; WARM UP SUITS; WET SUITS; WIND PANTS; YOGA PANTS (U.S. CLS. 22 AND 39).

JAMES A. RAUEN, EXAMINING ATTORNEY

CLASS 25—(Continued).

SN 85-294,266. WORLD RECORD SUMMIT, LLC, VENICE, CA. FILED 4-13-2011.

CONCEIVE DESIGN AND EXECUTE

THE MARK CONSISTS OF STANDARD CHARACTERS WITHOUT CLAIM TO ANY PARTICULAR FONT, STYLE, SIZE, OR COLOR.

FOR ATHLETIC APPAREL, NAMELY, SHIRTS, PANTS, JACKETS, FOOTWEAR, HATS AND CAPS, ATHLETIC UNIFORMS; BASEBALL CAPS AND HATS; BODY SHIRTS; BUTTON DOWN SHIRTS; CAMOUFLAGE SHIRTS; HATS; HEADBANDS FOR CLOTHING; HEADGEAR, NAMELY, HATS, BEANIES, HOODIES; HOODED SWEAT SHIRTS; JACKETS; JERSEYS; LONG-SLEEVED SHIRTS; SHORT-SLEEVED SHIRTS; SPORTS CAPS AND HATS; SPORTS SHIRTS; SPORTS SHIRTS WITH SHORT SLEEVES; SWEAT SHIRTS; T-SHIRTS; T-SHIRTS FOR KIDS, MEN AND WOMEN; TEE SHIRTS; TOBOGGAN HATS, PANTS AND CAPS; TRIATHLON CLOTHING, NAMELY, TRIATHLON TIGHTS, TRIATHLON SHORTS, TRIATHLON SINGLET, TRIATHLON SHIRTS, TRIATHLON SUITS; TURTLE NECK SHIRTS; WEARABLE GARMENTS AND CLOTHING, NAMELY, SHIRTS; WIND SHIRTS; WOMEN'S CLOTHING, NAMELY, SHIRTS, DRESSES, SKIRTS, BLOUSES; WOMEN'S HATS AND HOODS; WOOLLY HATS; YOGA SHIRTS (U.S. CLS. 22 AND 39).

ELIZABETH KAJUBI, EXAMINING ATTORNEY

SN 85-294,290. HAZUT, DON, LOS ANGELES, CA. FILED 4-13-2011.

WHITE MARK

THE MARK CONSISTS OF STANDARD CHARACTERS WITHOUT CLAIM TO ANY PARTICULAR FONT, STYLE, SIZE, OR COLOR.

FOR MEN'S, BOY'S, AND CHILDREN'S WEARING APPAREL, NAMELY, T-SHIRTS, SWEATSHIRTS, TANK TOPS, WOVEN SHIRTS, SWEATERS, CARDIGANS, VESTS, JACKETS, PANTS, SWEATPANTS, JEANS, SHORTS, HATS, CAPS, COATS, SCARVES, NECKERCHIEFS, NECK BANDS, WRIST BANDS, HEAD BANDS, GLOVES, BELTS WORN WITH CLOTHING, PAJAMAS, SHOES, SOCKS, UNDERWEAR, SWIM WEAR, AND TRUNKS; AND WOMEN'S, GIRL'S, AND CHILDREN'S WEARING APPAREL, NAMELY, T-SHIRTS, SWEATSHIRTS, TANK TOPS, WOVEN SHIRTS, SWEATERS, CARDIGANS, VESTS, JACKETS, PANTS, SWEATPANTS, JEANS, SHORTS, HATS, CAPS, COATS, BELTS WORN WITH CLOTHING, SCARVES, NECKERCHIEFS, NECK BANDS, WRIST BANDS, HEAD BANDS, GLOVES, PAJAMAS, SHOES, SOCKS, UNDERWEAR, FOUNDATION GARMENTS, PANTYHOSE, TEDDIES, BRAS, SKIRTS, DRESSES, BLOUSES, SWIM WEAR, AND BIKINIS (U.S. CLS. 22 AND 39).

JOHN HWANG, EXAMINING ATTORNEY

SN 85-294,128. HALO INNOVATIONS, INC., MINNETONKA, MN. FILED 4-13-2011.

HEALTHY HIPS

THE MARK CONSISTS OF STANDARD CHARACTERS WITHOUT CLAIM TO ANY PARTICULAR FONT, STYLE, SIZE, OR COLOR.

FOR INFANT DIAPER COVERS (U.S. CLS. 22 AND 39).
 NAAKWAMA ANKRAH, EXAMINING ATTORNEY

CLASS 25—(Continued).

SN 85-294,367. DEGAN BARBER, BILLINGS, MT. FILED 4-13-2011.

POSITIVE FLOW

THE MARK CONSISTS OF STANDARD CHARACTERS WITHOUT CLAIM TO ANY PARTICULAR FONT, STYLE, SIZE, OR COLOR.

FOR CLOTHING, NAMELY, SHIRTS, SHORTS, PANTS, SOCKS, AND HOODIES; FOOTWEAR, NAMELY, FLIP FLOPS (U.S. CLS. 22 AND 39).
EDWARD FENNESSY, EXAMINING ATTORNEY

SN 85-294,419. RAWLINGS SPORTING GOODS COMPANY, INC., ST. LOUIS, MO. FILED 4-13-2011.



THE MARK CONSISTS OF A DESIGN REPRESENTING A SHIRT COLLAR ABOVE AND CENTERED OVER THE TEXT UNIFORM SELECT.

FOR CLOTHING, NAMELY, SHIRTS, TIES, APRONS, JACKETS, HOODED JACKETS, MESH T-SHIRTS, T-SHIRTS, HATS, CAPS, VISORS, BUTTON UP SHIRTS, POLO SHIRTS, JERSEYS, PANTS, SHORTS (U.S. CLS. 22 AND 39).

KAREN K. BUSH, EXAMINING ATTORNEY

SN 85-294,484. NO ROOM, LLC, SEATTLE, WA. FILED 4-13-2011.



THE MARK CONSISTS OF THE STYLIZED TEXT "NR4E NO ROOM 4 ERROR".

FOR CAPS; COATS; HATS; HOODED SWEATSHIRTS; JACKETS; JEANS; PANTS; SHIRTS; SHORTS; SWEATERS; SWEATSHIRTS; T-SHIRTS; TANK TOPS; TOP COATS (U.S. CLS. 22 AND 39).

FIRST USE 2-15-2011; IN COMMERCE 3-28-2011.

ELISSA GARBER KON, EXAMINING ATTORNEY

CLASS 25—(Continued).

SN 85-294,525. PALIDIUM, INC., HUGO, MN. FILED 4-13-2011.

ZEROTIE

THE MARK CONSISTS OF STANDARD CHARACTERS WITHOUT CLAIM TO ANY PARTICULAR FONT, STYLE, SIZE, OR COLOR.

FOR FOOTWEAR (U.S. CLS. 22 AND 39).
DAVID H. STINE, EXAMINING ATTORNEY

SN 85-294,546. A. ALRADWAN AND PARTNER FOR GENERAL TRADING & CONTRACTING LLC, SAFAT, KUWAIT, FILED 4-13-2011.

MEXICAN ELEPHANT

THE MARK CONSISTS OF STANDARD CHARACTERS WITHOUT CLAIM TO ANY PARTICULAR FONT, STYLE, SIZE, OR COLOR.

FOR ATHLETIC APPAREL, NAMELY, SHIRTS, PANTS, JACKETS, FOOTWEAR, HATS AND CAPS, ATHLETIC UNIFORMS; SHOES; SLEEPWEAR; T-SHIRTS; UNDERWEAR (U.S. CLS. 22 AND 39).

FIRST USE 1-1-2008; IN COMMERCE 1-1-2008.
HANNO RITTNER, EXAMINING ATTORNEY

SN 85-294,609. CHANDELIERS AND BEERS, LLC, CULVER CITY, CA. FILED 4-13-2011.

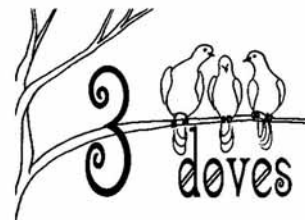

THE MARK CONSISTS OF 3 DRAWN, OUTLINED DOVE BIRDS AND A TREE, WITH A NUMBER "3", AND THE WORD "DOVES" BELOW THE DOVE BIRDS.

FOR HATS; JACKETS; SCARVES; SHIRTS (U.S. CLS. 22 AND 39).

FIRST USE 3-30-2011; IN COMMERCE 3-30-2011.

ALEX KEAM, EXAMINING ATTORNEY

CLASS 25—(Continued).

SN 85-294,701. SAVAGE, CHRISTIAN S., PHOENIX, AZ. FILED 4-13-2011.

3 HOURS BEHIND, LIGHT YEARS AHEAD

THE MARK CONSISTS OF STANDARD CHARACTERS WITHOUT CLAIM TO ANY PARTICULAR FONT, STYLE, SIZE, OR COLOR.
FOR T-SHIRTS (U.S. CLS. 22 AND 39).
KATHRYN COWARD, EXAMINING ATTORNEY

SN 85-294,723. HOKUA LLC, WHEAT RIDGE, CO. FILED 4-13-2011.

Hokua

THE MARK CONSISTS OF STANDARD CHARACTERS WITHOUT CLAIM TO ANY PARTICULAR FONT, STYLE, SIZE, OR COLOR.
THE ENGLISH TRANSLATION OF "HOKUA" IN THE MARK IS "CREST OF THE WAVE"
FOR ATHLETIC APPAREL, NAMELY, SHIRTS, PANTS, JACKETS, FOOTWEAR, HATS AND CAPS, ATHLETIC UNIFORMS; BOARD SHORTS; BOXER SHORTS; COLLARED SHIRTS; DRESS SHIRTS; HOODED SWEAT SHIRTS; LONG-SLEEVED SHIRTS; MOISTURE-WICKING SPORTS SHIRTS; SHIRTS; SHIRTS AND SHORT-SLEEVED SHIRTS; SHORT-SLEEVED SHIRTS; SHORTS; SPORT SHIRTS; SPORTS SHIRTS; SPORTS SHIRTS WITH SHORT SLEEVES; SWEAT SHIRTS; T-SHIRTS; TEE SHIRTS (U.S. CLS. 22 AND 39).
LINDA E. BLOHM, EXAMINING ATTORNEY

SN 85-294,957. SMOKED TERRAIN, UPPER MARLBORO, MD. FILED 4-14-2011.



THE MARK CONSISTS OF AN OUTLINE OF THREE SNOWBOARDERS AND A SKIER STANDING. TO THE LEFT THERE IS THE STYLIZED TEXT "SMOKED TERRAIN".
FOR GLOVES; HATS; JACKETS; PANTS; SHIRTS (U.S. CLS. 22 AND 39).
KATHERINE CHANG, EXAMINING ATTORNEY

CLASS 25—(Continued).

SN 85-294,991. PALOMBA, NICHOLAS, TAMPA, FL. FILED 4-14-2011.

Happy Hour is My Hour

THE MARK CONSISTS OF STANDARD CHARACTERS WITHOUT CLAIM TO ANY PARTICULAR FONT, STYLE, SIZE, OR COLOR.
FOR HATS; SHIRTS; SHOES (U.S. CLS. 22 AND 39).
INGRID C. EULIN, EXAMINING ATTORNEY

SN 85-294,994. HBI BRANDED APPAREL ENTERPRISES, LLC, WINSTON-SALEM, NC. FILED 4-14-2011.

SIMPLY SMOOTH

THE MARK CONSISTS OF STANDARD CHARACTERS WITHOUT CLAIM TO ANY PARTICULAR FONT, STYLE, SIZE, OR COLOR.
OWNER OF U.S. REG. NOS. 1,639,800, 2,931,506 AND 3,345,907.
FOR BRAS (U.S. CLS. 22 AND 39).
APRIL ROACH, EXAMINING ATTORNEY

SN 85-295,130. DAVIS, LARRY, QUEEN CREEK, AZ. FILED 4-14-2011.

GET XCITED

THE MARK CONSISTS OF STANDARD CHARACTERS WITHOUT CLAIM TO ANY PARTICULAR FONT, STYLE, SIZE, OR COLOR.
FOR HATS; HEADBANDS; INFANTS' SHOES AND BOOTS; JACKETS; LONG-SLEEVED SHIRTS; PANTS; POLO SHIRTS; SHIRTS; SHOES; SHORTS; SOCKS; TANK TOPS; WRISTBANDS (U.S. CLS. 22 AND 39).
FIRST USE 9-1-2010; IN COMMERCE 10-1-2010.
APRIL ROACH, EXAMINING ATTORNEY

CLASS 25—(Continued).

SN 85-295,136. FARLEY'S & SATHERS CANDY COMPANY, INC., ROUND LAKE, MN. FILED 4-14-2011.

JUM-BLO

THE MARK CONSISTS OF STANDARD CHARACTERS WITHOUT CLAIM TO ANY PARTICULAR FONT, STYLE, SIZE, OR COLOR.

OWNER OF U.S. REG. NO. 1,541,777.
FOR CLOTHING, NAMELY, SHIRTS, HATS, JACKETS, SWEATSHIRTS (U.S. CLS. 22 AND 39).
KAREN BRACEY, EXAMINING ATTORNEY

SN 85-295,139. DENHAM, LEIGH, LONG BEACH, CA. FILED 4-14-2011.

Your Soul Can Sing

THE MARK CONSISTS OF STANDARD CHARACTERS WITHOUT CLAIM TO ANY PARTICULAR FONT, STYLE, SIZE, OR COLOR.

FOR DRESSES; PANTS; SKIRTS; SWEAT SHIRTS; T-SHIRTS (U.S. CLS. 22 AND 39).
APRIL ROACH, EXAMINING ATTORNEY

SN 85-295,140. FARLEY'S & SATHERS CANDY COMPANY, INC., ROUND LAKE, MN. FILED 4-14-2011.

HEIDE

THE MARK CONSISTS OF STANDARD CHARACTERS WITHOUT CLAIM TO ANY PARTICULAR FONT, STYLE, SIZE, OR COLOR.

OWNER OF U.S. REG. NO. 243,976.
FOR CLOTHING, NAMELY, SHIRTS, HATS, JACKETS, SWEATSHIRTS (U.S. CLS. 22 AND 39).
KAREN BRACEY, EXAMINING ATTORNEY

CLASS 25—(Continued).

SN 85-295,144. FARLEY'S & SATHERS CANDY COMPANY, INC., ROUND LAKE, MN. FILED 4-14-2011.

RAIN-BLO HOT DOG!

THE MARK CONSISTS OF STANDARD CHARACTERS WITHOUT CLAIM TO ANY PARTICULAR FONT, STYLE, SIZE, OR COLOR.

OWNER OF U.S. REG. NOS. 786,497 AND 968,775.
FOR CLOTHING, NAMELY, SHIRTS, HATS, JACKETS, SWEATSHIRTS (U.S. CLS. 22 AND 39).
KAREN BRACEY, EXAMINING ATTORNEY

SN 85-295,424. KIM, JEAN P, GLENDALE, CA. AND TAO, CAROLYN, GLENDALE, CA. FILED 4-14-2011.

WHITE MAGNOLIA

THE MARK CONSISTS OF STANDARD CHARACTERS WITHOUT CLAIM TO ANY PARTICULAR FONT, STYLE, SIZE, OR COLOR.

FOR WOMEN'S CLOTHING, NAMELY, SHIRTS, DRESSES, SKIRTS, BLOUSES (U.S. CLS. 22 AND 39).
JAY FLOWERS, EXAMINING ATTORNEY

SN 85-295,492. BRITTANY DAY, COLLEYVILLE, TX. FILED 4-14-2011.



THE COLOR(S) BLUE, GREEN, BLACK AND RED IS/ARE CLAIMED AS A FEATURE OF THE MARK.

THE MARK CONSISTS OF GREEN YARN LOOSELY WRAPPED AROUND A BLUE CORE AND HAVING A BLACK TRAILING END EXTENDING TO THE RIGHT AND BENEATH THE STYLIZED WORD "GRUFF" IN RED.
FOR HOODED SCARVES, LEG WARMERS, ARM WARMERS, GLOVES AND MITTENS (U.S. CLS. 22 AND 39).
LINDA M. KING, EXAMINING ATTORNEY

CLASS 25—(Continued).

SN 85-295,591. BANANA SPLIT USA, INC., DANIA, FL. FILED 4-14-2011.



THE MARK CONSISTS OF A CARTOON VERSION OF A HIGHLY STYLIZED BREAKING WAVE.
FOR BIKINIS; BOARD SHORTS; COVERUPS; DRESSES; RASH GUARDS; SHIRTS; SHORTS; SWIM-SUITS; T-SHIRTS (U.S. CLS. 22 AND 39).
FIRST USE 0-0-2002; IN COMMERCE 0-0-2002.
RONALD DELGIZZI, EXAMINING ATTORNEY

SN 85-295,636. UNDERWARES LLC, HIGHLAND PARK, IL. FILED 4-14-2011.

comfyKitty

THE MARK CONSISTS OF STANDARD CHARACTERS WITHOUT CLAIM TO ANY PARTICULAR FONT, STYLE, SIZE, OR COLOR.
FOR WOMEN'S UNDERWEAR (U.S. CLS. 22 AND 39).
WENDY JUN, EXAMINING ATTORNEY

SN 85-295,660. L & L MANUFACURING CO., INC., EL SEGUNDO, CA. FILED 4-14-2011.

JOHNNY FOUND

THE MARK CONSISTS OF STANDARD CHARACTERS WITHOUT CLAIM TO ANY PARTICULAR FONT, STYLE, SIZE, OR COLOR.

THE NAME(S), PORTRAIT(S), AND/OR SIGNATURE(S) SHOWN IN THE MARK DOES NOT IDENTIFY A PARTICULAR LIVING INDIVIDUAL.

FOR CAPS; HOODED SWEATSHIRTS; KNIT TOPS; SWEATERS; SWEATSHIRTS; T-SHIRTS; TOPS (U.S. CLS. 22 AND 39).

PATRICIA EVANKO, EXAMINING ATTORNEY

CLASS 25—(Continued).

SN 85-295,713. ANTONIO CARMELO CULICETTO, MIAMI, FL. FILED 4-14-2011.

PICCADILLY CLOUD

THE MARK CONSISTS OF STANDARD CHARACTERS WITHOUT CLAIM TO ANY PARTICULAR FONT, STYLE, SIZE, OR COLOR.

FOR SHOES (U.S. CLS. 22 AND 39).
TEJBIR SINGH, EXAMINING ATTORNEY

SN 85-295,716. PALIDIUM, INC., HUGO, MN. FILED 4-14-2011.

ZEROTIE

THE MARK CONSISTS OF THE WORD ZEROTIE, THE "O" IN THE WORD BEING FORMED BY THE DESIGN OF A RATCHET WHEEL.

FOR FOOTWEAR (U.S. CLS. 22 AND 39).
DAVID H. STINE, EXAMINING ATTORNEY

SN 85-295,738. BYARS, ANDREW, BRADLEY, LITHONIA, GA. FILED 4-14-2011.

BEDOPE.

THE COLOR(S) BLACK IS/ARE CLAIMED AS A FEATURE OF THE MARK.

THE MARK CONSISTS OF THE FONT USED IS "IMPACT" AND THE ENTIRE PHRASE "BEDOPE." IS IN BLACK.

FOR WEARABLE GARMENTS AND CLOTHING, NAMELY, SHIRTS (U.S. CLS. 22 AND 39).

GRETTA YAO, EXAMINING ATTORNEY

CLASS 25—(Continued).

SN 85-295,790. WORLD RECORD SUMMIT, LLC, VENICE, CA. FILED 4-14-2011.

FROM SKETCH TO EXECUTION

THE MARK CONSISTS OF STANDARD CHARACTERS WITHOUT CLAIM TO ANY PARTICULAR FONT, STYLE, SIZE, OR COLOR.

FOR ATHLETIC APPAREL, NAMELY, SHIRTS, PANTS, JACKETS, FOOTWEAR, HATS AND CAPS, ATHLETIC UNIFORMS; BASEBALL CAPS AND HATS; HEADGEAR, NAMELY, HEADBANDS BANDANAS; SHORT-SLEEVED OR LONG-SLEEVED T-SHIRTS; SPORTS CAPS AND HATS; T-SHIRTS; T-SHIRTS FOR KIDS, WOMEN AND MEN; WOMEN'S HATS AND HOODS (U.S. CLS. 22 AND 39).

ELIZABETH KAJUBI, EXAMINING ATTORNEY

SN 85-295,823. DE CASTRO DE ARMAS, ALVARO ENRIQUE, MIAMI, FL. AND DEL POZO, SALVATORE, MIAMI, FL. FILED 4-14-2011.



THE MARK CONSISTS OF A SQUIRREL WITH THE STYLIZED TEXT "A.B.T. ALL 'BOUT TREES".

FOR BELTS; DRESS SHIRTS; HATS; JACKETS; LINGERIE; POLO SHIRTS; SWEATERS; T-SHIRTS; TIES (U.S. CLS. 22 AND 39).

SHAILA SETTLES, EXAMINING ATTORNEY

SN 85-296,624. OLD TOLEDO BRANDS, INC., NEW YORK, NY. FILED 4-15-2011.

PRIME CUTS

THE MARK CONSISTS OF STANDARD CHARACTERS WITHOUT CLAIM TO ANY PARTICULAR FONT, STYLE, SIZE, OR COLOR.

FOR CLOTHING, NAMELY, SHIRTS, T-SHIRTS, BLOUSES, TOPS, JACKETS, PANTS, SKIRTS, BOTTOMS, CAPS, HATS (U.S. CLS. 22 AND 39).

BRIAN PINO, EXAMINING ATTORNEY

CLASS 25—(Continued).

SN 85-296,729. LINDSEY, LUKE, AMARILLO, TX. FILED 4-15-2011.

GENERATION Rx

THE MARK CONSISTS OF STANDARD CHARACTERS WITHOUT CLAIM TO ANY PARTICULAR FONT, STYLE, SIZE, OR COLOR.

FOR BELTS; HATS; HOODED SWEATSHIRTS; JACKETS; SHIRTS (U.S. CLS. 22 AND 39).

PAM WILLIS, EXAMINING ATTORNEY

SN 85-296,737. GRABY, SARAH, BEACON, NY. FILED 4-15-2011.

Sparkle My Head Scarves
"Holding Your Spirits Up
In Style"

THE MARK CONSISTS OF STANDARD CHARACTERS WITHOUT CLAIM TO ANY PARTICULAR FONT, STYLE, SIZE, OR COLOR.

FOR EMBELLISHED KNIT JERSEY HEAD SCARVES (U.S. CLS. 22 AND 39).

FIRST USE 3-29-2011; IN COMMERCE 4-7-2011.
MATTHEW KLINE, EXAMINING ATTORNEY

SN 85-296,828. COLON, STEPHANIE, MOUNT HOLLY, NJ. FILED 4-15-2011.

NIELKI

THE MARK CONSISTS OF STANDARD CHARACTERS WITHOUT CLAIM TO ANY PARTICULAR FONT, STYLE, SIZE, OR COLOR.

FOR CLOTHING, NAMELY, TOPS, BOTTOMS, PANTS, SHIRTS, ONE-PIECE GARMENTS FOR CHILDREN, DRESSES, SHOES, SWEATERS, JACKETS, COATS, HATS, SWIMSUITS, TRUNKS, SHORTS, SKIRTS (U.S. CLS. 22 AND 39).

ANDREA HACK, EXAMINING ATTORNEY

CLASS 25—(Continued).

SN 85-296,891. NICE TEAM LLC, BEVERLY HILLS, CA. FILED 4-15-2011.

PEACE IS NICE!

THE MARK CONSISTS OF STANDARD CHARACTERS WITHOUT CLAIM TO ANY PARTICULAR FONT, STYLE, SIZE, OR COLOR.
FOR COATS; FOOTWEAR; GLOVES; HEADWEAR; JACKETS; PANTS; SWEAT PANTS; SWEAT SHIRTS; SWEAT SUITS; T-SHIRTS (U.S. CLS. 22 AND 39).
HENRY S. ZAK, EXAMINING ATTORNEY

SN 85-296,911. NICE TEAM LLC, BEVERLY HILLS, CA. FILED 4-15-2011.

LOVE IS NICE!

THE MARK CONSISTS OF STANDARD CHARACTERS WITHOUT CLAIM TO ANY PARTICULAR FONT, STYLE, SIZE, OR COLOR.
FOR COATS; FOOTWEAR; GLOVES; HEADWEAR; JACKETS; PANTS; SHIRTS; SHORTS; SOCKS; SWEAT PANTS; SWEAT SHIRTS; SWEATERS; T-SHIRTS (U.S. CLS. 22 AND 39).
HENRY S. ZAK, EXAMINING ATTORNEY

SN 85-296,935. CARRARA, CONNOR, DAVENPORT, IA. FILED 4-15-2011.



THE MARK CONSISTS OF LARGE BUBBLE, BORDERED LETTERS SPELLING "FLIBY".
FOR HATS; JACKETS; PANTS; SHIRTS (U.S. CLS. 22 AND 39).
FIRST USE 4-1-2008; IN COMMERCE 7-1-2010.
JOHN GARTNER, EXAMINING ATTORNEY

CLASS 25—(Continued).

SN 85-300,108. ALEX, TIMOTHY, MARINE CITY, MI. FILED 4-20-2011.

BRO-PILOT

THE MARK CONSISTS OF STANDARD CHARACTERS WITHOUT CLAIM TO ANY PARTICULAR FONT, STYLE, SIZE, OR COLOR.
FOR CLOTHING, NAMELY, T-SHIRTS, CAPS, SWEATSHIRTS, HOODED SHIRTS, HOODED SWEATSHIRTS, SHORTS, PANTS, LONG SLEEVE SHIRTS, TANK-TOPS (U.S. CLS. 22 AND 39).
FONG HSU, EXAMINING ATTORNEY

SN 85-300,354. APIFENI, INC., POTOMAC, MD. FILED 4-20-2011.



THE MARK CONSISTS OF STYLIZED FIVE-PETALLED FLOWER SURMOUNTED BY THREE DOTS.
FOR BATHING SUITS; BRAS; CAMISOLES; CAPRI PANTS; COATS; CYCLING SHORTS; FOOTWEAR; GIRDLES; GYM SHORTS; HATS; JACKETS; JEGGINGS, NAMELY, PANTS THAT ARE PARTIALLY JEANS AND PARTIALLY LEGGINGS; LEGGINGS; LEOTARDS; PANTIES; PANTS; PANTYHOSE; SHIRTS; SHORTS; SKIWEAR; SLACKS; SLIPS; SOCKS; SPORTS BRAS; SPORTS PANTS; SPORTS SHIRTS; SPORTS VESTS; SWEATERS; SWEATPANTS; SWEATSHIRTS; T-SHIRTS; TANK TOPS; TIGHTS; TOPS; TROUSERS; UNDERWEAR; WOMEN'S ATHLETIC TOPS WITH BUILT-IN BRAS; WOMEN'S TOPS, NAMELY, CAMIS; WRAPS (U.S. CLS. 22 AND 39).
CAROLYN CATALDO, EXAMINING ATTORNEY

SN 85-300,567. NO ROOM, LLC, SEATTLE, WA. FILED 4-20-2011.

NO ROOM 4 ERROR

THE MARK CONSISTS OF STANDARD CHARACTERS WITHOUT CLAIM TO ANY PARTICULAR FONT, STYLE, SIZE, OR COLOR.
FOR CAPS; COATS; HATS; HOODED SWEATSHIRTS; JACKETS; JEANS; PANTS; SHIRTS; SHORTS; SWEATERS; SWEATSHIRTS; T-SHIRTS (U.S. CLS. 22 AND 39).
FIRST USE 2-15-2011; IN COMMERCE 3-28-2011.
ELISSA GARBER KON, EXAMINING ATTORNEY

CLASS 25—(Continued).

SN 85-301,398. WRANGLER APPAREL CORP., WILMINGTON, DE. FILED 4-21-2011.



OWNER OF U.S. REG. NO. 3,899,246.
 THE MARK CONSISTS OF A STYLIZED "W" IN A ROPE
 FORMAT INSIDE A CIRCLE.
 FOR CLOTHING, NAMELY, TOPS, BOTTOMS,
 DRESSES, SWEATERS, VESTS, JACKETS, UNDER-
 WEAR, SOCKS, HOSIERY, LOUNGEWEAR, SLEEP-
 WEAR, ROBES, BELTS, SUSPENDERS, TIES,
 BANDANAS, SCARVES, GLOVES AND MITTENS;
 FOOTWEAR; HEADWEAR (U.S. CLS. 22 AND 39).
 SIMON TENG, EXAMINING ATTORNEY

SN 85-301,922. WRANGLER APPAREL CORP., WILMINGTON, DE. FILED 4-22-2011.

ROOM2REACH

THE MARK CONSISTS OF STANDARD CHARACTERS
 WITHOUT CLAIM TO ANY PARTICULAR FONT, STYLE,
 SIZE, OR COLOR.
 OWNER OF U.S. REG. NO. 3,512,443.
 FOR CLOTHING, NAMELY, TOPS, BOTTOMS,
 DRESSES, SWEATERS, VESTS, JACKETS, UNDER-
 WEAR, SOCKS, HOSIERY, LOUNGEWEAR, SLEEP-
 WEAR, ROBES, BELTS, SUSPENDERS, TIES,
 BANDANAS, SCARVES, GLOVES AND MITTENS;
 FOOTWEAR; HEADWEAR (U.S. CLS. 22 AND 39).
 SIMON TENG, EXAMINING ATTORNEY

SN 85-304,058. SKECHERS U.S.A., INC. II, MANHATTAN BEACH, CA. FILED 4-25-2011.

GET BACK IN THE GAME

THE MARK CONSISTS OF STANDARD CHARACTERS
 WITHOUT CLAIM TO ANY PARTICULAR FONT, STYLE,
 SIZE, OR COLOR.
 FOR FOOTWEAR (U.S. CLS. 22 AND 39).
 KATHRYN COWARD, EXAMINING ATTORNEY

CLASS 25—(Continued).

SN 85-305,258. LEVI STRAUSS & CO., SAN FRANCISCO, CA. FILED 4-26-2011.

550

THE MARK CONSISTS OF STANDARD CHARACTERS
 WITHOUT CLAIM TO ANY PARTICULAR FONT, STYLE,
 SIZE, OR COLOR.
 FOR JEANS; PANTS; SHORTS (U.S. CLS. 22 AND 39).
 FIRST USE 12-0-1988; IN COMMERCE 12-0-1988.
 MICHAEL WEBSTER, EXAMINING ATTORNEY

SN 85-306,852. FANPLAY, INC., SLATON, TX. FILED 4-28-2011.

**FANPLAY WE ARE "TEAM"
 SPORTS**

THE MARK CONSISTS OF STANDARD CHARACTERS
 WITHOUT CLAIM TO ANY PARTICULAR FONT, STYLE,
 SIZE, OR COLOR.
 FOR CAPS WITH VISORS; T-SHIRTS; VISORS (U.S.
 CLS. 22 AND 39).
 LESLIE RICHARDS, EXAMINING ATTORNEY

SN 85-308,076. FANPLAY, INC., SLATON, TX. FILED 4-29-2011.

FANPLAY NATION

THE MARK CONSISTS OF STANDARD CHARACTERS
 WITHOUT CLAIM TO ANY PARTICULAR FONT, STYLE,
 SIZE, OR COLOR.
 FOR CAPS WITH VISORS; T-SHIRTS; VISORS (U.S.
 CLS. 22 AND 39).
 LESLIE RICHARDS, EXAMINING ATTORNEY

CLASS 25—(Continued).

SN 85-308,138. ONEFASTBUFFALO CORP, DALLAS, TX.
FILED 4-29-2011.

ONEFASTCO

THE MARK CONSISTS OF STANDARD CHARACTERS
WITHOUT CLAIM TO ANY PARTICULAR FONT, STYLE,
SIZE, OR COLOR.
FOR PANTS; SHOES; T-SHIRTS (U.S. CLS. 22 AND 39).
NORA BUCHANAN WILL, EXAMINING ATTORNEY

SN 85-308,421. WEST PLANET GROUP, DBA LITTLE LOCOS
CLOTHING, TAMPA, FL. FILED 4-29-2011.

Little Locos Clothing

THE MARK CONSISTS OF STANDARD CHARACTERS
WITHOUT CLAIM TO ANY PARTICULAR FONT, STYLE,
SIZE, OR COLOR.
NO CLAIM IS MADE TO THE EXCLUSIVE RIGHT TO
USE "CLOTHING", APART FROM THE MARK AS SHOWN.
FOR HOODED SWEAT SHIRTS; LONG-SLEEVED
SHIRTS; NIGHT SHIRTS; POLO SHIRTS; SHIRTS;
SHORT-SLEEVED SHIRTS; SLEEP SHIRTS; SWEAT
SHIRTS; T-SHIRTS (U.S. CLS. 22 AND 39).
FIRST USE 1-22-2011; IN COMMERCE 4-22-2011.
BRENDAN MCCAULEY, EXAMINING ATTORNEY

SN 85-308,558. CONFIDENCE MATTERS, YORBA LINDA,
CA. FILED 4-29-2011.

Confidence Matters

THE MARK CONSISTS OF STANDARD CHARACTERS
WITHOUT CLAIM TO ANY PARTICULAR FONT, STYLE,
SIZE, OR COLOR.
FOR BEANIES; HATS; HEADBANDS; HOODED
SWEATSHIRTS; JACKETS; POLO SHIRTS; SHORT-
SLEEVED OR LONG-SLEEVED T-SHIRTS; SOCKS;
SPORTS BRA; SWEAT SUITS; SWEATSHIRTS; TANK
TOPS; UNDERWEAR; WRISTBANDS (U.S. CLS. 22 AND
39).
ANTHONY RINKER, EXAMINING ATTORNEY

CLASS 25—(Continued).

SN 85-308,701. FANPLAY, INC., SLATON, TX. FILED 4-29-
2011.

FANPLAY HEROES

THE MARK CONSISTS OF STANDARD CHARACTERS
WITHOUT CLAIM TO ANY PARTICULAR FONT, STYLE,
SIZE, OR COLOR.
FOR CAPS WITH VISORS; T-SHIRTS; VISORS (U.S.
CLS. 22 AND 39).
LESLIE RICHARDS, EXAMINING ATTORNEY

SN 85-309,285. SANSONE, JAMES, NEW ORLEANS, LA.
FILED 5-1-2011.

Fraegi

THE MARK CONSISTS OF STANDARD CHARACTERS
WITHOUT CLAIM TO ANY PARTICULAR FONT, STYLE,
SIZE, OR COLOR.
FOR CLOTHING, NAMELY, SHIRTS, T-SHIRTS,
JACKETS, SWEATSHIRTS, SHORTS, CAPS, HATS (U.S.
CLS. 22 AND 39).
ALICE BENMAMAN, EXAMINING ATTORNEY

SN 85-309,610. CHRISTINA AMERICA INC., SAINT-LAUR-
ENT, QUEBEC, CANADA, FILED 5-2-2011.

STUDIO BY SEA

THE MARK CONSISTS OF STANDARD CHARACTERS
WITHOUT CLAIM TO ANY PARTICULAR FONT, STYLE,
SIZE, OR COLOR.
FOR SWIMWEAR AND ACCESSORIES, NAMELY
SWIMSUITS, PAREOS, BEACH COVER-UPS, SHORTS,
SHIRTS, TOPS, NAMELY BLOUSES, SWEATERS,
SHIRTS, TANK TOPS AND HALTERS, JACKETS AND
T-SHIRTS (U.S. CLS. 22 AND 39).
HEATHER SAPP, EXAMINING ATTORNEY

CLASS 25—(Continued).

SN 85-310,497. RAMSAY, ELIZABETH, JACKSONVILLE, FL.
FILED 5-3-2011.

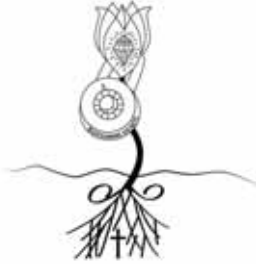

THE MARK CONSISTS OF AN IMAGE OF CURVED LINE DEPICTING THE SOIL BELOW WHICH THERE IS AN IMAGE OF ROOTS WITH A CROSS SYMBOL AT THE BOTTOM. ABOVE THE SOIL THERE IS A FLOWER WITH A SPARKLING DIAMOND IN THE CENTER WHICH IS ENLOCKED AND THE WORDS BLOSSOMING SECRETS ARE WRITTEN OVER THE LOCK AS SHOWN IN THE MARK.

FOR CLOTHING, NAMELY, TOPS, BOTTOMS, SHIRTS, T-SHIRTS, PANTS, FOOTWEAR, HEADWEAR, UNDERWEAR, SLEEPWEAR, BEACHWEAR, LOUNGEWEAR, NECKWEAR, RAIN WEAR, SWIM WEAR (U.S. CLS. 22 AND 39).

JAMES A. RAUEN, EXAMINING ATTORNEY

SN 85-313,871. NOLL, JED, SAN CLEMENTE, CA. AND
NOLL, GREG, SAN CLEMENTE, CA. FILED 5-5-2011.



THE MARK CONSISTS OF THE SILHOUETTE OF A MAN STANDING ALONG THE LEFT SIDE OF A LONG UPRIGHT SURFBOARD.

FOR BEACH FOOTWEAR; BEANIES; BOARD SHORTS; FLIP FLOPS; HATS; HOODED SWEATSHIRTS; PANTS; SANDALS; SHIRTS; SHORTS; SWEATERS; SWEATSHIRTS (U.S. CLS. 22 AND 39).

FIRST USE 7-0-1991; IN COMMERCE 6-0-1993.
SUSAN RICHARDS, EXAMINING ATTORNEY

CLASS 25—(Continued).

SN 85-314,065. LONGLIVENY, LLC, RIVERDALE, NY.
FILED 5-6-2011.



THE MARK CONSISTS OF THE STYLIZED TEXT "LLNY".

FOR BASEBALL CAPS; SWEATSHIRTS; T-SHIRTS (U.S. CLS. 22 AND 39).

JASON TURNER, EXAMINING ATTORNEY

SN 85-317,471. CONFIDENCE MATTERS, YORBA LINDA,
CA. FILED 5-10-2011.

UNLOCK YOUR POTENTIAL

THE MARK CONSISTS OF STANDARD CHARACTERS WITHOUT CLAIM TO ANY PARTICULAR FONT, STYLE, SIZE, OR COLOR.

FOR BEANIES; HATS; HEADBANDS; HOODED SWEATSHIRTS; JACKETS; POLO SHIRTS; SOCKS; SPORTS BRA; SWEAT SUITS; SWEATSHIRTS; T-SHIRTS; TANK TOPS; UNDERWEAR; WRISTBANDS (U.S. CLS. 22 AND 39).

ANTHONY RINKER, EXAMINING ATTORNEY

SN 85-317,917. ACI INTERNATIONAL, LOS ANGELES, CA.
FILED 5-11-2011.



NO CLAIM IS MADE TO THE EXCLUSIVE RIGHT TO USE "SOLES", APART FROM THE MARK AS SHOWN.

THE MARK CONSISTS OF THE STYLIZED WORDING "BUYAMBA SOLES" IN FRONT OF A STYLIZED HAND-PRINT DESIGN WITH A SPIRAL AS THE PALM.

THE ENGLISH TRANSLATION OF "BUYAMBA" IN THE MARK IS "HELP".

FOR FOOTWEAR (U.S. CLS. 22 AND 39).
NELSON SNYDER, EXAMINING ATTORNEY

CLASS 25—(Continued).

SN 85-318,040. SKECHERS U.S.A., INC. II, MANHATTAN BEACH, CA. FILED 5-11-2011.

RESAGRIP

THE MARK CONSISTS OF STANDARD CHARACTERS WITHOUT CLAIM TO ANY PARTICULAR FONT, STYLE, SIZE, OR COLOR.

FOR FOOTWEAR (U.S. CLS. 22 AND 39).
KATHRYN COWARD, EXAMINING ATTORNEY

CLASS 25—(Continued).

SN 85-319,519. TONY MARGERIE & ASSOCIATES, SAUSA-LITO, CA. FILED 5-12-2011.



SN 85-318,426. TONY MARGERIE & ASSOCIATES, SAUSA-LITO, CA. FILED 5-11-2011.

SUPERBLAST

OWNER OF U.S. REG. NOS. 1,613,960, 1,887,253 AND 2,579,122.

THE MARK CONSISTS OF BLACK CHEETAH ON TOP OF THE WORD SUPERBLAST.

FOR BELTS; CAPS; FOOTWEAR; HATS; HOSIERY; JACKETS; JERSEYS; PANTS; SCARVES; SHORTS; SKIRTS; SOCKS; SWEAT SHIRTS; SWEATERS; T-SHIRTS; TOPS; UNDERWEAR; VESTS (U.S. CLS. 22 AND 39).

REGINA DRUMMOND, EXAMINING ATTORNEY

THE MARK CONSISTS OF STANDARD CHARACTERS WITHOUT CLAIM TO ANY PARTICULAR FONT, STYLE, SIZE, OR COLOR.

OWNER OF U.S. REG. NOS. 1,613,960, 2,579,122 AND OTHERS.

FOR BELTS; CAPS; FOOTWEAR; HATS; HOSIERY; JACKETS; JERSEYS; PANTS; SCARVES; SHORTS; SKIRTS; SOCKS; SWEAT SHIRTS; SWEATERS; T-SHIRTS; TOPS; UNDERWEAR; VESTS (U.S. CLS. 22 AND 39).

REGINA DRUMMOND, EXAMINING ATTORNEY

SN 85-320,061. LUCCHESI, INC., EL PASO, TX. FILED 5-13-2011.



SN 85-318,952. HBI BRANDED APPAREL ENTERPRISES, LLC, WINSTON-SALEM, NC. FILED 5-12-2011.

SIMPLY SIZED

THE MARK CONSISTS OF STANDARD CHARACTERS WITHOUT CLAIM TO ANY PARTICULAR FONT, STYLE, SIZE, OR COLOR.

FOR BRAS (U.S. CLS. 22 AND 39).
APRIL ROACH, EXAMINING ATTORNEY

OWNER OF U.S. REG. NOS. 916,764, 1,835,901 AND OTHERS.

THE MARK CONSISTS OF A DRAWING OF A COWGIRL ABOVE THE STYLIZED WORD "SPIRIT" ABOVE THE WORDS "BY LUCCHESI".

FOR BOOTS; MOCCASINS; SANDALS; SHOES (U.S. CLS. 22 AND 39).

FIRST USE 1-0-2011; IN COMMERCE 1-0-2011.

CORY BOONE, EXAMINING ATTORNEY

CLASS 25—(Continued).

SN 85-320,129. TONY MARGERIE & ASSOCIATES, SAUSALITO, CA. FILED 5-13-2011.



OWNER OF U.S. REG. NOS. 1,613,960, 2,579,122 AND OTHERS.

THE MARK CONSISTS OF ROUND OWL WITH LARGE CIRCULAR EYES WITH A PUPIL IN THE MIDDLE, HAIR TUFTS ON EACH SIDE OF THE OWL, A TRIANGULAR NOSE, 3 LINES FOR EACH FOOT AND THE WORD SUPERBLAST CIRCLING THE DEPICTION OF THE OWL.

FOR BELTS; CAPS; FOOTWEAR; HATS; HOSIERY; JACKETS; JERSEYS; PANTS; SCARVES; SHORTS; SKIRTS; SOCKS; SWEAT SHIRTS; SWEATERS; T-SHIRTS; TOPS; UNDERWEAR; VESTS (U.S. CLS. 22 AND 39).

REGINA DRUMMOND, EXAMINING ATTORNEY

CLASS 25—(Continued).

SN 85-324,961. SCI DIRECT, LLC, NORTH CANTON, OH. FILED 5-19-2011.

PRETTY FIT

THE MARK CONSISTS OF STANDARD CHARACTERS WITHOUT CLAIM TO ANY PARTICULAR FONT, STYLE, SIZE, OR COLOR.

FOR BASEBALL CAPS; CAPS; FOOTWEAR; GLOVES; HATS; HEADWEAR; HOODED SWEAT SHIRTS; JACKETS; LEOTARDS; MOISTURE-WICKING SPORTS PANTS; PANTS; SHIRTS; SHORTS; SOCKS; SWEAT PANTS; SWEAT SHIRTS; SWEAT SUITS; SWEATERS; T-SHIRTS; TANK TOPS; TIGHTS; TOPS; VISORS; YOGA PANTS (U.S. CLS. 22 AND 39).

JENNY PARK, EXAMINING ATTORNEY

SN 85-326,225. LIVE NATION WORLDWIDE, INC., BEVERLY HILLS, CA. FILED 5-20-2011.

VENUE NATION

THE MARK CONSISTS OF STANDARD CHARACTERS WITHOUT CLAIM TO ANY PARTICULAR FONT, STYLE, SIZE, OR COLOR.

FOR CLOTHING, NAMELY, SHIRTS, T-SHIRTS, RUGBY SHIRTS, POLO SHIRTS, CARDIGANS, JERSEYS, UNIFORMS, PANTS, TANK TOPS, SWEAT SHIRTS, SWEAT PANTS, WARM-UP SUITS, AND JACKETS (U.S. CLS. 22 AND 39).

DAVID HOFFMAN, EXAMINING ATTORNEY

SN 85-321,031. ALAN HENDERSON, BONITA SPRINGS, FL. FILED 5-13-2011.

SWITCHATS

THE MARK CONSISTS OF STANDARD CHARACTERS WITHOUT CLAIM TO ANY PARTICULAR FONT, STYLE, SIZE, OR COLOR.

FOR BASEBALL CAPS AND HATS; HATS; HATS FOR INFANTS, BABIES, TODDLERS AND CHILDREN; HEADGEAR, NAMELY, HATS, VISORS; SPORTS CAPS AND HATS (U.S. CLS. 22 AND 39).

GENE MACIOL, EXAMINING ATTORNEY

SN 85-326,687. ESFANDI, JOSEPH, BEVERLY HILLS, CA. FILED 5-21-2011.



THE MARK CONSISTS OF THE LITERAL ELEMENTS "SKULL & BEAR" BELOW THE SYMBOL OF SKULL AND BEAR. THE LITERAL ELEMENTS ARE SEPARATED BY A PLUS SIGN.

FOR CLOTHING, NAMELY, TOPS, BOTTOMS, T-SHIRTS, SHIRTS, SWEATSHIRTS, JACKETS, JEANS, SHORTS, UNDERWEAR, SOCKS, SCARFS, AND BELTS (U.S. CLS. 22 AND 39).

KATHERINE M. DUBRAY, EXAMINING ATTORNEY

CLASS 25—(Continued).

SN 85-327,957. CANNA PROMOTIONS, LLC, COLORADO SPRINGS, CO. FILED 5-23-2011.

CANNATOONZ

THE MARK CONSISTS OF STANDARD CHARACTERS WITHOUT CLAIM TO ANY PARTICULAR FONT, STYLE, SIZE, OR COLOR.

FOR T-SHIRTS, SWEATSHIRTS, BASEBALL CAPS, HATS, UNDERWEAR, JACKETS, FLEECE TOPS, SCARVES, SLEEPWEAR, SOCKS AND TANKTOPS (U.S. CLS. 22 AND 39).

LINDSEY RUBIN, EXAMINING ATTORNEY

SN 85-327,966. CANNA PROMOTIONS, LLC, COLORADO SPRINGS, CO. FILED 5-23-2011.

CANNATEEZ

THE MARK CONSISTS OF STANDARD CHARACTERS WITHOUT CLAIM TO ANY PARTICULAR FONT, STYLE, SIZE, OR COLOR.

FOR T-SHIRTS, SWEATSHIRTS, BASEBALL CAPS, HATS, UNDERWEAR, JACKETS, FLEECE TOPS, SCARVES, SLEEPWEAR, SOCKS AND TANKTOPS (U.S. CLS. 22 AND 39).

ROBERT STRUCK, EXAMINING ATTORNEY

SN 85-334,455. IPANEMA INC., WATSONVILLE, CA. FILED 5-31-2011.

Nico and Valentina

THE MARK CONSISTS OF STANDARD CHARACTERS WITHOUT CLAIM TO ANY PARTICULAR FONT, STYLE, SIZE, OR COLOR.

OWNER OF U.S. REG. NOS. 3,183,173 AND 3,738,738. FOR FOOTWEAR; FOOTWEAR FOR WOMEN (U.S. CLS. 22 AND 39).

FIRST USE 1-1-2011; IN COMMERCE 3-1-2011.

KATHLEEN M. VANSTON, EXAMINING ATTORNEY

CLASS 25—(Continued).

SN 85-339,855. SALT LIFE HOLDINGS, LLC, JACKSONVILLE, FL. FILED 6-7-2011.

SALT LIFE

THE MARK CONSISTS OF STANDARD CHARACTERS WITHOUT CLAIM TO ANY PARTICULAR FONT, STYLE, SIZE, OR COLOR.

OWNER OF U.S. REG. NOS. 2,959,429, 3,843,123 AND OTHERS.

FOR CLOTHING AND APPAREL, NAMELY, WET SUITS, JACKETS, PANTS, SHOES, SANDALS, AND SWEATERS (U.S. CLS. 22 AND 39).

JORDAN BAKER, EXAMINING ATTORNEY

SN 85-344,647. BARILLA G. E. R. FRATELLI - SOCIETÀ PER AZIONI, PARMA, ITALY, FILED 6-13-2011.

SPAGHETTATA

THE MARK CONSISTS OF STANDARD CHARACTERS WITHOUT CLAIM TO ANY PARTICULAR FONT, STYLE, SIZE, OR COLOR.

FOR CLOTHING, NAMELY, T-SHIRTS, SWEATSHIRTS, JACKETS, PANTS, SHORTS, SWEATERS, HATS, APRONS (U.S. CLS. 22 AND 39).

AISHA CLARKE, EXAMINING ATTORNEY

CLASS 26—FANCY GOODS

SN 77-621,812. SHAKE-N-GO FASHION, INC., PORT WASHINGTON, NY. FILED 11-25-2008.

IKON

THE MARK CONSISTS OF STANDARD CHARACTERS WITHOUT CLAIM TO ANY PARTICULAR FONT, STYLE, SIZE, OR COLOR.

FOR HAIR PRODUCTS, NAMELY, WIGS AND ADD-ON HAIR ACCESSORIES, NAMELY, PONYTAILS AND HAIR PIECES CONSTRUCTED PRIMARILY OF HUMAN HAIR; HAIR EXTENSIONS (U.S. CLS. 37, 39, 40, 42 AND 50).

FIRST USE 1-3-2008; IN COMMERCE 1-3-2008.

KIM SAITO, EXAMINING ATTORNEY

CLASS 26—(Continued).

SN 85-139,219. CHO, YOUNG SOO, DBA EVE HAIR, INC., LAKEWOOD, CA. FILED 9-27-2010.



NO CLAIM IS MADE TO THE EXCLUSIVE RIGHT TO USE "INDIAN," "REMY," OR "PREMIUM VIRGIN HAIR", APART FROM THE MARK AS SHOWN.

THE MARK CONSISTS OF THE STYLIZED WORDING "INDIAN REMY PREMIUM VIRGIN HAIR" AND DESIGN. THE DESIGN CONSISTS OF THREE LIONS SITTING ON A PEDESTAL BELOW WHICH ARE TWO SIDE VIEWS OF LIONS ON EITHER SIDE OF A CIRCLE DESIGN.

FOR CLOWN WIGS MADE FROM REMY VIRGIN HAIR; HAIR PIECES AND WIGS MADE FROM REMY VIRGIN HAIR; TAPE FOR FIXING WIGS; WIG CAPS; WIGS MADE FROM REMY VIRGIN HAIR; WIGS, HAIRPIECES, AND ADD-IN AND ADD-ON HAIR ACCESSORIES CONSTRUCTED PRIMARILY OF REMY VIRGIN HUMAN HAIR (U.S. CLS. 37, 39, 40, 42 AND 50).

FIRST USE 7-1-2007; IN COMMERCE 9-14-2010.
BRIAN PINO, EXAMINING ATTORNEY

CLASS 26—(Continued).

SN 85-229,380. BONNER, RACHEL, A, DUBLIN, CA. AND BONNER, LESLIE, C, DUBLIN, CA. FILED 1-29-2011.



THE NAME(S), PORTRAIT(S), AND/OR SIGNATURE(S) SHOWN IN THE MARK IDENTIFIES RACHEL A. BONNER, WHOSE CONSENT(S) TO REGISTER IS MADE OF RECORD.

THE COLOR(S) ROYAL BLUE, WHITE, LIGHT BLUE, AND GOLD IS/ARE CLAIMED AS A FEATURE OF THE MARK.

THE MARK CONSISTS OF A ROYAL BLUE RIBBON TRIMMED IN GOLD, A WHITE AND LIGHT BLUE DOVE TRIMMED IN GOLD OVERLAYED ON ROYAL BLUE RIBBON WITH THE ROYAL BLUE LETTER "R" IN THE RIBBON LOOP AND ROYAL BLUE LETTER "A" BETWEEN THE RIBBON ENDS AND THE ROYAL BLUE LETTERING OF THE WORD "BONNER" AT THE BASE OF THE DESIGN. FOR FRAMED LOGO, NAMELY, FRAMED EMBROIDERY (U.S. CLS. 37, 39, 40, 42 AND 50).

FIRST USE 1-1-2011; IN COMMERCE 1-24-2011.
MARK SPARACINO, EXAMINING ATTORNEY

SN 85-148,958. NCGALLERY COM INC, DBA NCGC USA, RALEIGH, NC. FILED 10-8-2010.

Wynga

THE MARK CONSISTS OF STANDARD CHARACTERS WITHOUT CLAIM TO ANY PARTICULAR FONT, STYLE, SIZE, OR COLOR.

FOR WIGS, HAIRPIECES, AND ADD-IN AND ADD-ON HAIR ACCESSORIES CONSTRUCTED PRIMARILY OF SYNTHETIC AND/OR HUMAN HAIR (U.S. CLS. 37, 39, 40, 42 AND 50).

FIRST USE 2-14-2009; IN COMMERCE 10-31-2009.
CHRISTINE MARTIN, EXAMINING ATTORNEY

SN 85-273,073. HANSON, MICHELLE, RAYNHAM, MA. FILED 3-22-2011.



THE COLOR(S) BROWN, RED, PINK, AND GREEN IS/ARE CLAIMED AS A FEATURE OF THE MARK.

THE MARK CONSISTS OF THREE LONG STEM, RED, PINK, AND GREEN FLOWERS WITH "LILLIEMAGS" IN BROWN WRITTEN UNDERNEATH OF FLOWERS.

FOR ARTIFICIAL FLORAL ARRANGEMENTS MADE IN PART OF MAGAZINES AND PLACED IN GLASS CONTAINERS (U.S. CLS. 37, 39, 40, 42 AND 50).

RICHARD WHITE, EXAMINING ATTORNEY

CLASS 26—(Continued).

SN 85-274,270. NEW IMAGE GROUP LLC, UNION, SC.
FILED 3-23-2011.

FUN BUTTONS

THE MARK CONSISTS OF STANDARD CHARACTERS WITHOUT CLAIM TO ANY PARTICULAR FONT, STYLE, SIZE, OR COLOR.

NO CLAIM IS MADE TO THE EXCLUSIVE RIGHT TO USE "BUTTONS", APART FROM THE MARK AS SHOWN. FOR NOVELTY BUTTONS (U.S. CLS. 37, 39, 40, 42 AND 50).

FIRST USE 1-1-1988; IN COMMERCE 1-1-1988.
DOMINICK J. SALEMI, EXAMINING ATTORNEY

SN 85-274,320. NEW IMAGE GROUP LLC, UNION, SC.
FILED 3-23-2011.

SURPRIZE RIBBON

THE MARK CONSISTS OF STANDARD CHARACTERS WITHOUT CLAIM TO ANY PARTICULAR FONT, STYLE, SIZE, OR COLOR.

NO CLAIM IS MADE TO THE EXCLUSIVE RIGHT TO USE "RIBBON", APART FROM THE MARK AS SHOWN. FOR FELT RIBBONS (U.S. CLS. 37, 39, 40, 42 AND 50).
DOMINICK J. SALEMI, EXAMINING ATTORNEY

SN 85-275,876. TRIPLE AUGHT DESIGN, LLC, SAN FRANCISCO, CA. FILED 3-24-2011.

TRIPLE AUGHT DESIGN

THE MARK CONSISTS OF STANDARD CHARACTERS WITHOUT CLAIM TO ANY PARTICULAR FONT, STYLE, SIZE, OR COLOR.

OWNER OF U.S. REG. NO. 3,338,705.
NO CLAIM IS MADE TO THE EXCLUSIVE RIGHT TO USE "DESIGN", APART FROM THE MARK AS SHOWN. FOR ORNAMENTAL CLOTH PATCHES (U.S. CLS. 37, 39, 40, 42 AND 50).

FIRST USE 2-1-1997; IN COMMERCE 9-30-2010.
JOHN SCHUYLER YARD, EXAMINING ATTORNEY

CLASS 26—(Continued).

SN 85-280,562. HAIR SOLUTIONS BY M.E., INC., MCLEAN, VA. FILED 3-29-2011.

FEELsoREAL

THE MARK CONSISTS OF STANDARD CHARACTERS WITHOUT CLAIM TO ANY PARTICULAR FONT, STYLE, SIZE, OR COLOR.

FOR SYNTHETIC HAIR EXTENSIONS (U.S. CLS. 37, 39, 40, 42 AND 50).

JACLYN KIDWELL WALKER, EXAMINING ATTORNEY

SN 85-326,241. LIVE NATION WORLDWIDE, INC., BEVERLY HILLS, CA. FILED 5-20-2011.

VENUE NATION

THE MARK CONSISTS OF STANDARD CHARACTERS WITHOUT CLAIM TO ANY PARTICULAR FONT, STYLE, SIZE, OR COLOR.

FOR ORNAMENTAL NOVELTY BUTTONS AND PINS (U.S. CLS. 37, 39, 40, 42 AND 50).

DAVID HOFFMAN, EXAMINING ATTORNEY

CLASS 27—FLOOR COVERINGS

SN 79-091,380. PLASTIC EXTRUDERS LIMITED, ESSEX, UNITED KINGDOM, FILED 11-29-2010.

HERON

THE MARK CONSISTS OF STANDARD CHARACTERS WITHOUT CLAIM TO ANY PARTICULAR FONT, STYLE, SIZE, OR COLOR.

OWNER OF INTERNATIONAL REGISTRATION 1062002 DATED 11-29-2010, EXPIRES 11-29-2020.

FOR MATS INCLUDED IN THIS CLASS, ALL MADE FROM EXTRUDED PLASTICS, NAMELY, FLOOR MATS; COVERINGS FOR EXISTING FLOORS, ALL MADE FROM EXTRUDED PLASTICS (U.S. CLS. 19, 20, 37, 42 AND 50).

JAMES MACFARLANE, EXAMINING ATTORNEY

CLASS 27—(Continued).

SN 85-112,120. PREFERRED BRANDS, BURNSVILLE, MN.
FILED 8-20-2010.



The logo for "Natural Trends" features the word "Natural" in a cursive script font above the word "Trends" in a smaller, sans-serif font. Two horizontal lines are positioned below the word "Natural".

THE MARK CONSISTS OF "NATURAL" IN STYLIZED FONT WITH TWO LINES BELOW IT; "TRENDS" APPEARS SLIGHTLY BELOW AND TO THE RIGHT OF "NATURAL" IN STYLIZED FONT.

FOR CARPET BACKING; CARPET PADDING; CARPET TILES; CARPET UNDERLAY; CARPETS (U.S. CLS. 19, 20, 37, 42 AND 50).

FIRST USE 9-0-2007; IN COMMERCE 9-0-2007.
MICHAEL ENGEL, EXAMINING ATTORNEY

CLASS 27—(Continued).

SN 85-315,643. MOHAWK CARPET DISTRIBUTION, INC.,
CHATSWORTH, GA. FILED 5-9-2011.

ECOSTRAND

THE MARK CONSISTS OF STANDARD CHARACTERS WITHOUT CLAIM TO ANY PARTICULAR FONT, STYLE, SIZE, OR COLOR.

FOR FIBER SOLD AS A COMPONENT OF CARPET (U.S. CLS. 19, 20, 37, 42 AND 50).

PAULA MAHONEY, EXAMINING ATTORNEY

SN 85-283,908. MOHAWK CARPET DISTRIBUTION, INC.,
CHATSWORTH, GA. FILED 4-1-2011.

UNIBOND FLEX

THE MARK CONSISTS OF STANDARD CHARACTERS WITHOUT CLAIM TO ANY PARTICULAR FONT, STYLE, SIZE, OR COLOR.

OWNER OF U.S. REG. NOS. 1,844,537, 3,734,643 AND OTHERS.

NO CLAIM IS MADE TO THE EXCLUSIVE RIGHT TO USE "FLEX", APART FROM THE MARK AS SHOWN.

FOR CARPET BACKING (U.S. CLS. 19, 20, 37, 42 AND 50).

PAULA MAHONEY, EXAMINING ATTORNEY

SN 85-315,668. MOHAWK CARPET DISTRIBUTION, INC.,
CHATSWORTH, GA. FILED 5-9-2011.

GREENSTRAND

THE MARK CONSISTS OF STANDARD CHARACTERS WITHOUT CLAIM TO ANY PARTICULAR FONT, STYLE, SIZE, OR COLOR.

OWNER OF U.S. REG. NOS. 3,674,067, 3,941,575 AND OTHERS.

FOR ENVIRONMENTALLY FRIENDLY FIBER SOLD AS A COMPONENT OF CARPET (U.S. CLS. 19, 20, 37, 42 AND 50).

PAULA MAHONEY, EXAMINING ATTORNEY

SN 85-283,938. MOHAWK CARPET DISTRIBUTION, INC.,
CHATSWORTH, GA. FILED 4-1-2011.

UNIBOND FLEX BLOC

THE MARK CONSISTS OF STANDARD CHARACTERS WITHOUT CLAIM TO ANY PARTICULAR FONT, STYLE, SIZE, OR COLOR.

OWNER OF U.S. REG. NOS. 1,844,537, 3,734,643 AND OTHERS.

NO CLAIM IS MADE TO THE EXCLUSIVE RIGHT TO USE "FLEX", APART FROM THE MARK AS SHOWN.

FOR CARPET BACKING (U.S. CLS. 19, 20, 37, 42 AND 50).

PAULA MAHONEY, EXAMINING ATTORNEY

SN 85-315,778. MOHAWK CARPET DISTRIBUTION, INC.,
CHATSWORTH, GA. FILED 5-9-2011.

ENVIROSTRAND

THE MARK CONSISTS OF STANDARD CHARACTERS WITHOUT CLAIM TO ANY PARTICULAR FONT, STYLE, SIZE, OR COLOR.

FOR FIBER SOLD AS A COMPONENT OF CARPET (U.S. CLS. 19, 20, 37, 42 AND 50).

PAULA MAHONEY, EXAMINING ATTORNEY

CLASS 27—(Continued).

SN 85-316,029. HOME DYNAMIX LLC., MOONACHIE, NJ.
FILED 5-9-2011.

Relief Mat

THE MARK CONSISTS OF STANDARD CHARACTERS WITHOUT CLAIM TO ANY PARTICULAR FONT, STYLE, SIZE, OR COLOR.

NO CLAIM IS MADE TO THE EXCLUSIVE RIGHT TO USE "MAT", APART FROM THE MARK AS SHOWN.

FOR ANTI-FATIGUE FLOOR MAT (U.S. CLS. 19, 20, 37, 42 AND 50).

TIMOTHY FINNEGAN, EXAMINING ATTORNEY

CLASS 28—TOYS AND SPORTING GOODS

SN 76-707,238. EB BRANDS HOLDINGS, INC., YONKERS, NY. FILED 4-12-2011.

Turn Key

THE MARK CONSISTS OF STANDARD CHARACTERS WITHOUT CLAIM TO ANY PARTICULAR FONT, STYLE, SIZE, OR COLOR.

FOR MANUALLY OPERATED HAND HELD EXERCISE EQUIPMENT (U.S. CLS. 22, 23, 38 AND 50).

ALLISON HOLTZ, EXAMINING ATTORNEY

SN 85-316,056. HOME DYNAMIX LLC., MOONACHIE, NJ.
FILED 5-9-2011.

Premier Kitchen

THE MARK CONSISTS OF STANDARD CHARACTERS WITHOUT CLAIM TO ANY PARTICULAR FONT, STYLE, SIZE, OR COLOR.

NO CLAIM IS MADE TO THE EXCLUSIVE RIGHT TO USE "KITCHEN", APART FROM THE MARK AS SHOWN.

FOR FLOOR MATS (U.S. CLS. 19, 20, 37, 42 AND 50).

TIMOTHY FINNEGAN, EXAMINING ATTORNEY

SN 77-351,521. SPIN MASTER LTD., TORONTO ONTARIO, CANADA, FILED 12-13-2007.

STREET CREW

SN 85-317,216. L&P PROPERTY MANAGEMENT COMPANY, SOUTH GATE, CA. FILED 5-10-2011.

BIOBASIC

THE MARK CONSISTS OF STANDARD CHARACTERS WITHOUT CLAIM TO ANY PARTICULAR FONT, STYLE, SIZE, OR COLOR.

FOR NATURAL SEED OIL POLYOL AS AN INTEGRAL COMPONENT OF REBOND FOAM CARPET CUSHION (U.S. CLS. 19, 20, 37, 42 AND 50).

FIRST USE 1-0-2008; IN COMMERCE 1-0-2008.

KATHERINE STOIDES, EXAMINING ATTORNEY

THE MARK CONSISTS OF STANDARD CHARACTERS WITHOUT CLAIM TO ANY PARTICULAR FONT, STYLE, SIZE, OR COLOR.

PRIORITY CLAIMED UNDER SEC. 44(D) ON CANADA APPLICATION NO. 1361748, FILED 8-30-2007, REG. NO. TMA793067, DATED 3-16-2011, EXPIRES 3-16-2026.

FOR TOYS, GAMES AND PLAYTHINGS, NAMELY, COLLECTABLE FIGURES, MINIATURE SKATEBOARDS AND ACCESSORIES, NAMELY, MINIATURE RAMPS AND MINIATURE OBSTACLES RELATED TO SKATEBOARDING (U.S. CLS. 22, 23, 38 AND 50).

JASON BLAIR, EXAMINING ATTORNEY

CLASS 28—(Continued).

SN 77-631,343. KNUT, BUDIG, KOLN, FED REP GERMANY, AND KASELER, DANIEL GILBRETH, PORT ANGELES, WA. FILED 12-11-2008.

VANDAL

THE MARK CONSISTS OF STANDARD CHARACTERS WITHOUT CLAIM TO ANY PARTICULAR FONT, STYLE, SIZE, OR COLOR.

PRIORITY CLAIMED UNDER SEC. 44(D) ON ERP CMNTY TM OFC APPLICATION NO. 007005325, FILED 6-12-2008, REG. NO. 007005325, DATED 6-8-2011, EXPIRES 6-12-2018.

FOR SURFBOARDS; SAILBOARDS; SNOWBOARDS; WAKEBOARDS, SAIL MASTS FOR SURFBOARDS, FOOT STRAPS FOR SURFBOARDS; BAGS FOR SURFBOARDS AND SURFBOARD ACCESSORIES, SURFBAGS ESPECIALLY DESIGNED FOR SURFBOARDS; SNOWBOARD BAGS; SKATEBOARDS; KITES FOR USE WITH KITEBOARDS; WINDSURFING ARTICLES AND KITEBOARDING ARTICLES, NAMELY, SAILS AND MATS; KITES; KITE ACCESSORIES AND WINDSURFING ACCESSORIES, NAMELY, ROPES AND COUPLINGS (U.S. CLS. 22, 23, 38 AND 50).

RAUL CORDOVA, EXAMINING ATTORNEY

SN 77-915,574. REIZEN, RICHARD A, LAUDERDALE BY THE SEA, FL. FILED 1-20-2010.

WOODS & WATER

THE MARK CONSISTS OF STANDARD CHARACTERS WITHOUT CLAIM TO ANY PARTICULAR FONT, STYLE, SIZE, OR COLOR.

FOR BOARD GAMES; DICE GAMES; PARLOR GAMES; PARLOUR GAMES (U.S. CLS. 22, 23, 38 AND 50).

FIRST USE 5-28-1995; IN COMMERCE 5-28-1995.
REBECCA SMITH, EXAMINING ATTORNEY

CLASS 28—(Continued).

SN 79-089,586. ACTOY APS, DK-4500 NYKØBING SJÆLLAND, DENMARK, FILED 9-1-2010.



OWNER OF INTERNATIONAL REGISTRATION 1057208 DATED 9-1-2010, EXPIRES 9-1-2020.

THE COLOR(S) GREEN AND BLACK IS/ARE CLAIMED AS A FEATURE OF THE MARK.

THE MARK CONSISTS OF THE WORD "ACTOY" IN STYLIZED GREEN LETTERS WITH THE WORDING "ACTIVITY TO YOU" IN BLACK UNDER THE WORD "ACTOY".

FOR TOY STILTS (U.S. CLS. 22, 23, 38 AND 50).
DAWN FELDMAN, EXAMINING ATTORNEY

SN 79-093,244. NANTONG LIVEUP SPORTS CO., LTD, JIANGSU, CHINA, FILED 1-4-2011.



OWNER OF INTERNATIONAL REGISTRATION 1066899 DATED 1-4-2011, EXPIRES 1-4-2021.

NO CLAIM IS MADE TO THE EXCLUSIVE RIGHT TO USE "SPORTS", APART FROM THE MARK AS SHOWN.

THE MARK CONSISTS OF THE STYLIZED WORDING "LIVEUP" ABOVE THE WORD "SPORTS" CONTAINED IN A SHADED RECTANGULAR CARRIER.

FOR BALLS FOR GAMES; RACKETS FOR TABLE TENNIS OR TENNIS OR BADMINTON; BODY-TRAINING APPARATUS; DUMBBELLS; ANKLE AND WRIST WEIGHTS FOR EXERCISE; ELBOW GUARDS FOR ATHLETIC USE; TOY MOBILES FOR CHILDREN (U.S. CLS. 22, 23, 38 AND 50).

JOHN SCHUYLER YARD, EXAMINING ATTORNEY

CLASS 28—(Continued).

SN 85-001,389. KENNEY, JAKE, BEVERLY HILLS, MI.
FILED 3-29-2010.

SCORPION 

THE MARK CONSISTS OF THE CAPITALIZED WORD "SCORPION" IN A STYLIZED FONT, FOLLOWED BY A PICTURE OF A DIGITALLY RENDERED SCORPION DRAWING INSIDE A CIRCLE WITH THE TOP OPEN, POINTED UPWARDS. THE MARK FOR THE PICTURE OF THE SCORPION GIVES THE RENDERING OF THE ANIMAL SCORPION THE LOOK OF BEING INSIDE TWO PARENTHETICAL PINCERS, ENCIRCLING THE SCORPION.

FOR FIELD HOCKEY GLOVES; FIELD HOCKEY GOALIE PADS; FIELD HOCKEY STICKS; FOOTBALL BODY PROTECTORS; FOOTBALL ELBOW PADS; FOOTBALL GLOVES; FOOTBALL LEG PADS; FOOTBALL SHOULDER PADS; HOCKEY GLOVES; HOCKEY STICKS; ICE HOCKEY GOALIE PADS; LACROSSE GLOVES; LACROSSE STICKS; PADS FOR USE IN SHOULDER PADS FOR USE IN HOCKEY AND LACROSSE; SPORTS EQUIPMENT FOR BOXING AND MARTIAL ARTS, NAMELY, BOXING GLOVES, BOXING BAGS, PUNCHING MITTS, BELLY PROTECTORS, GROIN PROTECTORS AND SHIN GUARDS (U.S. CLS. 22, 23, 38 AND 50).

FIRST USE 1-0-2007; IN COMMERCE 1-0-2007.
DAVID COLLIER, EXAMINING ATTORNEY

CLASS 28—(Continued).

SN 85-063,880. SHRUNKEN HEAD STUDIOS, BURBANK, CA. FILED 6-16-2010.

SHRUNKEN HEAD STUDIOS

THE MARK CONSISTS OF STANDARD CHARACTERS WITHOUT CLAIM TO ANY PARTICULAR FONT, STYLE, SIZE, OR COLOR.

NO CLAIM IS MADE TO THE EXCLUSIVE RIGHT TO USE "STUDIOS", APART FROM THE MARK AS SHOWN.

FOR ACTION FIGURES; ACTION FIGURES AND ACCESSORIES THEREFOR; COLLECTABLE TOY FIGURES; MOLDED TOY FIGURES; PLAY FIGURES; PLAY SETS FOR ACTION FIGURES; POSITIONABLE TOY FIGURES; TOY ACTION FIGURES; TOY ACTION FIGURES AND ACCESSORIES THEREFOR; TOY FIGURES (U.S. CLS. 22, 23, 38 AND 50).

SARA BENJAMIN, EXAMINING ATTORNEY

SN 85-099,616. LITTLE WING WORLD, LLC, MIAMI BEACH, FL. FILED 8-4-2010.

WHISTLERS WORLD

SN 85-018,399. CARLTON SPORTS COMPANY LIMITED, SHIREBROOK, UNITED KINGDOM, FILED 4-20-2010.

CARLTON

THE MARK CONSISTS OF STANDARD CHARACTERS WITHOUT CLAIM TO ANY PARTICULAR FONT, STYLE, SIZE, OR COLOR.

OWNER OF ERPN CMNTY TM OFC REG. NO. 001087659, DATED 7-3-2000, EXPIRES 2-22-2019.

FOR RACKETS AND STRINGS FOR RACKETS; RACKET STRING PROTECTORS; TABLE TENNIS TABLES; BALLS FOR RACKET SPORTS; SHUTTLECOCKS; HANDLE GRIPS FOR SPORTS RACKETS; RACKET GRIP TAPE AND GRIP BANDS; NETS FOR BALL GAMES; NETS FOR SPORTS; BAGS SPECIALLY ADAPTED FOR RACKET SPORTS EQUIPMENT; BAGS SPECIALLY ADAPTED FOR SPORTS RACKETS; HEAD COVERS FOR SPORTS RACKETS; PROTECTIVE COVERS FOR RACKETS; BADMINTON GAME PLAYING EQUIPMENT; BADMINTON SETS (U.S. CLS. 22, 23, 38 AND 50).

LINDA POWELL, EXAMINING ATTORNEY

THE MARK CONSISTS OF STANDARD CHARACTERS WITHOUT CLAIM TO ANY PARTICULAR FONT, STYLE, SIZE, OR COLOR.

FOR TOYS FOR CHILDREN, NAMELY, RUBBER ACTION BALLS, ACTION FIGURES, STAND ALONE VIDEO GAME MACHINES, PLUSH DOLLS, PLUSH TOYS, CLOTHING FOR DOLLS, CLOTHING FOR PLUSH DOLLS, CLOTHING FOR PLUSH TOYS; PLUSH DOLL AND TOY ACCESSORIES, NAMELY, TOY FURNITURE AND TOY JEWELRY; MULTIPLE ACTIVITY TOYS FOR BABIES; BABY RATTLES; BALLOONS; BATH TOYS; CRIB MOBILES; CRIB TOYS; DOLLS, DOLL ACCESSORIES; PAPER DOLLS; PUPPETS; SOFT SCULPTURE DOLLS; PARTY FAVORS IN THE NATURE OF SMALL TOYS AND NOISEMAKERS; PUZZLES; KITES; DOLL COSTUMES; COSTUME MASKS; TOY MOBILES; WATER SQUIRTING TOYS; CHRISTMAS TREE ORNAMENTS AND CHRISTMAS STOCKINGS; MODELED PLASTIC TOY FIGURINES; SAND TOYS, NAMELY, TOY PLASTIC PAIL AND TOY PLASTIC SHOVEL; CONSTRUCTION TOYS; TOY BUILDING BLOCKS; BOARD GAMES; CARD GAMES; TRADING CARD GAMES; TOY MUSICAL INSTRUMENTS (U.S. CLS. 22, 23, 38 AND 50).

CHRISTINA SOBRAL, EXAMINING ATTORNEY

CLASS 28—(Continued).

SN 85-112,072. MATTEL, INC., EL SEGUNDO, CA. FILED 8-20-2010.

MADE BY ME!

THE MARK CONSISTS OF STANDARD CHARACTERS WITHOUT CLAIM TO ANY PARTICULAR FONT, STYLE, SIZE, OR COLOR.

FOR DRAWING TOYS; CHILDRENS' ART ACTIVITY TABLE (U.S. CLS. 22, 23, 38 AND 50).

SKYE YOUNG, EXAMINING ATTORNEY

SN 85-120,431. ROBOBUILDER CO., LTD., SEOUL, REPUBLIC OF KOREA, FILED 9-1-2010.

SMARTBOT

THE MARK CONSISTS OF STANDARD CHARACTERS WITHOUT CLAIM TO ANY PARTICULAR FONT, STYLE, SIZE, OR COLOR.

PRIORITY CLAIMED UNDER SEC. 44(D) ON REPUBLIC OF KOREA APPLICATION NO. 40-2010-0012, FILED 3-12-2010, REG. NO. 0862979, DATED 5-2-2011, EXPIRES 5-2-2021.

FOR TOYS, NAMELY, REMOTE CONTROLLED MOBILE TOY IN THE NATURE OF ROBOTS; GAMES, NAMELY, REMOTE CONTROLLED TOY MOBILE ROBOT GAME CONTROLLED VIA COMPUTER GAME SOFTWARE; DOLLS, NAMELY, REMOTE CONTROLLED MOBILE DOLLS (U.S. CLS. 22, 23, 38 AND 50).

SUSAN LESLIE DUBOIS, EXAMINING ATTORNEY

SN 85-124,964. ZERO SKATEBOARDS LLC, CARLSBAD, CA. FILED 9-8-2010.

THREAT

THE MARK CONSISTS OF STANDARD CHARACTERS WITHOUT CLAIM TO ANY PARTICULAR FONT, STYLE, SIZE, OR COLOR.

FOR SKATEBOARD PARTS, NAMELY, DECKS, WHEELS, TRUCKS, BEARINGS AND BOLTS; SKATEBOARD WAX (U.S. CLS. 22, 23, 38 AND 50).

FIRST USE 8-12-2010; IN COMMERCE 8-12-2010.

KHANH LE, EXAMINING ATTORNEY

CLASS 28—(Continued).

SN 85-125,857. CANARIAM S.A.S., MEDELLÍN, COLOMBIA, FILED 9-9-2010.



OWNER OF COLOMBIA REG. NO. 331054, DATED 4-27-2007, EXPIRES 4-27-2017.

THE MARK CONSISTS OF A CIRCULAR ABSTRACT DESIGN CONTAINING LITTLE DOTS OVER A SOLID BACKGROUND FOLLOWED BY THE WORD "CANARIAM" IN STYLIZED LETTERS OVER A BACKGROUND CONTAINING LITTLE DOTS, THE ENTIRE DESIGN APPEARING INSIDE A RECTANGLE.

THE WORDING "CANARIAM" HAS NO MEANING IN A FOREIGN LANGUAGE.

FOR BAGS FOR SKATEBOARDS; BALL BEARINGS FOR ROLLER SKATES; BALL BEARINGS FOR SKATEBOARDS; LONGBOARD WHEELS; LONGBOARDS; NUTS AND BOLTS FOR SKATEBOARDS; ROLLER SKATES; SKATEBOARD DECKS; SKATEBOARD GRIP TAPES; SKATEBOARD RISER PADS; SKATEBOARD TRUCKS; SKATEBOARD WHEELS; SKATEBOARDS; SKATING BOOTS WITH SKATES ATTACHED; SPORTS EQUIPMENT, NAMELY, INLINE ROLLER SKATING WHEELS AT THE END OF A CRUTCH-LIKE FRAME (U.S. CLS. 22, 23, 38 AND 50).

TINA L. SNAPP, EXAMINING ATTORNEY

SN 85-127,925. MATTEL, INC., EL SEGUNDO, CA. FILED 9-13-2010.

UNO ROBOTO

THE MARK CONSISTS OF STANDARD CHARACTERS WITHOUT CLAIM TO ANY PARTICULAR FONT, STYLE, SIZE, OR COLOR.

OWNER OF U.S. REG. NOS. 1,005,397, 2,444,828 AND OTHERS.

THE ENGLISH TRANSLATION OF "UNO" IN THE MARK IS "ONE".

FOR CARD GAME AND ELECTRONIC TOY ROBOT FIGURE SOLD TOGETHER AS A UNIT (U.S. CLS. 22, 38 AND 50).

JACQUELINE A. LAVINE, EXAMINING ATTORNEY

CLASS 28—(Continued).

SN 85-132,688. THINKING TECHNOLOGY, INC., NASSAU, BAHAMAS, FILED 9-17-2010.

PENGUIN PETS

THE MARK CONSISTS OF STANDARD CHARACTERS WITHOUT CLAIM TO ANY PARTICULAR FONT, STYLE, SIZE, OR COLOR.

NO CLAIM IS MADE TO THE EXCLUSIVE RIGHT TO USE "PENGUIN", APART FROM THE MARK AS SHOWN. FOR PLASTIC TOY FIGURES (U.S. CLS. 22, 23, 38 AND 50).

ARETHA SOMERVILLE, EXAMINING ATTORNEY

CLASS 28—(Continued).

SN 85-145,898. FOX, DAVID WILLIAM, WARRENTON, VA. FILED 10-6-2010.

CULTURE POP

THE MARK CONSISTS OF STANDARD CHARACTERS WITHOUT CLAIM TO ANY PARTICULAR FONT, STYLE, SIZE, OR COLOR.

FOR PARTY GAMES (U.S. CLS. 22, 23, 38 AND 50). KRISTINA MORRIS, EXAMINING ATTORNEY

SN 85-139,680. AQUA-LEISURE INDUSTRIES, INC., AVON, MA. FILED 9-28-2010.

WATER LIFE

THE MARK CONSISTS OF STANDARD CHARACTERS WITHOUT CLAIM TO ANY PARTICULAR FONT, STYLE, SIZE, OR COLOR.

NO CLAIM IS MADE TO THE EXCLUSIVE RIGHT TO USE "WATER", APART FROM THE MARK AS SHOWN.

FOR INFLATABLE FLOATING RECREATIONAL LOUNGE CHAIRS, CHAIRS, RECLINING CHAIRS AND INFLATABLE TUBES FOR USE IN AND AROUND WATER (U.S. CLS. 22, 23, 38 AND 50).

KAREN BRACEY, EXAMINING ATTORNEY

SN 85-169,701. MATTEL, INC., EL SEGUNDO, CA. FILED 11-4-2010.

ULTIMATE CRUSH KIT

THE MARK CONSISTS OF STANDARD CHARACTERS WITHOUT CLAIM TO ANY PARTICULAR FONT, STYLE, SIZE, OR COLOR.

NO CLAIM IS MADE TO THE EXCLUSIVE RIGHT TO USE "KIT", APART FROM THE MARK AS SHOWN.

FOR TOY VEHICLE PLAYSETS AND ACCESSORIES THEREFOR (U.S. CLS. 22, 23, 38 AND 50). JENNIFER MARTIN, EXAMINING ATTORNEY

SN 85-143,977. MITCHELL, MICHAEL, NASHUA, NH. FILED 10-4-2010.

WORLDS WITHIN

THE MARK CONSISTS OF STANDARD CHARACTERS WITHOUT CLAIM TO ANY PARTICULAR FONT, STYLE, SIZE, OR COLOR.

FOR FANTASY AND ROLE PLAYING GAMES, NAMELY, PARLOR GAMES, TRADING CARD GAMES, BOARD GAMES, CARD GAMES, FANTASY ROLE PLAYING GAMES, COLLECTABLE TOY ACTION FIGURES AND ACCESSORIES FOR USE THEREWITH; COLLECTABLE TOY FIGURES; DICE; EQUIPMENT SOLD AS A UNIT FOR PLAYING BOARD GAMES, NAMELY, GAME BOARDS AND GAME PIECES (U.S. CLS. 22, 23, 38 AND 50).

KIMBERLY FRYE, EXAMINING ATTORNEY

SN 85-172,088. SAUNDERS PERFORMANCE GROUP LTD, DELTA, CANADA, FILED 11-9-2010.

SEE IT, ROLL IT, HOLE IT

THE MARK CONSISTS OF STANDARD CHARACTERS WITHOUT CLAIM TO ANY PARTICULAR FONT, STYLE, SIZE, OR COLOR.

FOR GOLF TRAINING AIDS IN THE NATURE OF GOLF PUTTING PRACTICE SYSTEMS COMPRISED PRIMARILY OF TARGET GATES, STANCE RULERS, AND FEEDBACK MIRRORS (U.S. CLS. 22, 23, 38 AND 50).

SUSAN STIGLITZ, EXAMINING ATTORNEY

CLASS 28—(Continued).

SN 85-182,173. LEE OLIVER, HUNTINGTON BEACH, CA.
FILED 11-22-2010.



OWNER OF U.S. REG. NOS. 3,724,890 AND 3,901,114.
THE MARK CONSISTS OF A CLAW IN STYLIZED FORM.
FOR SURF FINNS; SURFBOARD FINNS (U.S. CLS. 22, 23,
38 AND 50).
DAVID HOFFMAN, EXAMINING ATTORNEY

SN 85-188,413. RAWLINGS SPORTING GOODS COMPANY,
INC., ST. LOUIS, MO. FILED 12-1-2010.



NO CLAIM IS MADE TO THE EXCLUSIVE RIGHT TO
USE "EST. 1887", APART FROM THE MARK AS SHOWN.

THE MARK CONSISTS OF A BACKGROUND IN THE
MIDDLE OF WHICH IS A SCRIPT WORD "RAWLINGS" AT
A SLIGHT ANGLE UPWARDS FROM LOWER LEFT TO
UPPER RIGHT. BELOW THE WORD "RAWLINGS" AND
CUTTING ACROSS THE TAIL OF THE "R" IS AN OVAL
CONTAINING A SCRIPT LETTER "R". ABOVE AND
BELOW THE CENTERED WORD AND LOGO ARE DOUBLE
HORIZONTAL LINES FROM LOWER LEFT TO UPPER
RIGHT. BELOW THE LOWER HORIZONTAL LINE IS THE
LANGUAGE "EST. 1887".

FOR BASEBALL BATting TEES; SOFTBALL BAT-
TING TEES; BASEBALL TRAINING PLATES, NAMELY,
HOME PLATES, PITCHERS PLATES; SOFTBALL TRAIN-
ING PLATES, NAMELY, HOME PLATES, PITCHERS
PLATES; SPORTS KNEE PADS; SPORTS ELBOW PADS;
BASEBALL PITCHBACKS, NAMELY, BALL REBOUN-
DING SCREENS; SOFTBALL PITCHBACKS, NAMELY,
BALL REBOUNding SCREENS; FOOTBALL PITCH-
BACKS, NAMELY, BALL REBOUNding SCREENS;
BASES FOR BASEBALL; BASES FOR SOFTBALL; PRAC-
TICE NETS FOR SPORTS, NAMELY, THROWING NETS
FOR BASEBALL; THROWING NETS FOR SOFTBALL;
THROWING NETS FOR FOOTBALL; HITTING NETS
FOR BASEBALL; HITTING NETS FOR SOFTBALL;
HITTING NETS FOR FOOTBALL; SOCCER BALLS;
PUMPS ESPECIALLY ADAPTED FOR USE WITH BALLS
FOR GAMES; PROTECTIVE PADDING FOR SPORTS IN
THE NATURE OF SHIN SLEEVES; SPORTS SHIN
GUARDS; SOCCER GOALS; PRACTICE NETS FOR
SPORTS, NAMELY, SOCCER REBOUNders; SPORTS
FIELD EQUIPMENT, NAMELY, SPORTS MARKER
CONES; SPORTS GOAL NETS; VOLLEYBALLS; SPORTS
FIELD EQUIPMENT, NAMELY, COACHES STANDS;
SPIKE TRAINERS, NAMELY, BLOCKING DUMMIES;
BUNGEE BLOCKERS FOR FOOTBALL; SPORTS NET
STORAGE RACKS; SPORTS BALL STORAGE RACKS;
SPORTS FIELD EQUIPMENT, NAMELY, REFEREE
STANDS; SPORTS FIELD EQUIPMENT, NAMELY,
FOOTBALL LINESMAN FLAGS; BASEBALL TARGET

CLASS 28—(Continued).

TRAINERS; SOFTBALL TARGET TRAINERS; FOOT-
BALL TARGET TRAINERS; BASKETBALLS; PRACTICE
NETS FOR SPORTS, NAMELY, BASEBALL BALL RE-
TURN NETS, SOFTBALL BALL RETURN NETS, FOOT-
BALL BALL RETURN NETS; BASEBALL NETS;
SOFTBALL NETS; FOOTBALL NETS; SOCCER NETS;
FOOTBALL KICK TEES; PROTECTIVE PADDING FOR
FOOTBALL FIELD GOALS; PRACTICE NETS FOR
SPORTS, NAMELY, FOOTBALL KICK NETS; FOOT-
BALL SHOULDER PAD STORAGE RACKS; BASEBALL
HELMET STORAGE RACKS; SOFTBALL HELMET STO-
RAGE RACKS; FOOTBALL HELMET STORAGE RACKS;
FOOTBALL FACEGUARD REMOVAL TOOLS; FOOT-
BALL SHOULDER PAD LACES FOR ATHLETIC USE;
FOOTBALL BLOCKING PADS FOR FOOTBALL PRAC-
TICE; FOOTBALL TACKLING SHIELDS; FOOTBALL
AGILITY BLOCKING DUMMIES; FOOTBALL PULL
SLEDS; FOOTBALL FOREARM PADS; BAGS SPE-
CIALLY ADAPTED FOR SPORTS BALLS; SPORTS
FIELD EQUIPMENT, NAMELY, SPORTS PYLONS,
FOOTBALL DOWN BOXES, DOWN CHAINS, HOCKEY
PENALTY FLAGS, FOOTBALL SIDELINE MARKERS,
HOCKEY SIDELINE MARKERS, FOOTBALL SIDELINE
FLAGS, SOCCER SIDELINE FLAGS; TRAMPOLINES;
TOY SCOOTERS; STREET HOCKEY EQUIPMENT,
NAMELY, HOCKEY NETS, ATHLETIC PROTECTIVE
PADS; HOCKEY STICKS; BALLS FOR PLAYING
STREET HOCKEY; PORTABLE BASKETBALL HOOPS;
SKATE BOARDS; PROTECTIVE PADS FOR SKATE-
BOARDING (U.S. CLS. 22, 23, 38 AND 50).
LEIGH LOWRY, EXAMINING ATTORNEY

SN 85-207,540. WORLD WRESTLING ENTERTAINMENT,
INC., STAMFORD, CT. FILED 12-29-2010.

TOUGH ENOUGH

THE MARK CONSISTS OF STANDARD CHARACTERS
WITHOUT CLAIM TO ANY PARTICULAR FONT, STYLE,
SIZE, OR COLOR.

FOR TOY ACTION FIGURES AND ACCESSORIES
THEREFOR; CASES FOR ACTION FIGURES; TOY
VEHICLES; BOARD GAMES; PLAYING CARDS; TOY
SPINNING TOPS; STAND ALONE VIDEO OUTPUT
GAME MACHINES; ARCADE GAMES; PINBALL
GAMES; HAND-HELD UNITS FOR PLAYING ELEC-
TRONIC GAME OTHER THAN THOSE ADOPTED FOR
USE WITH AN ELECTRONIC DISPLAY SCREEN OR
MONITOR; TABLETOP ACTION SKILL GAMES; JIG-
SAW PUZZLES; KITES; DOLLS; BOBBLE-HEAD DOLLS;
PUPPETS; STUFFED TOY ANIMALS; CARD GAMES;
WATER GUNS; CHRISTMAS TREE DECORATIONS;
COSTUME MASKS; DOLL FURNITURE; SKATE-
BOARDS; WINDUP TOYS; TOY SCOOTERS; YO-YO'S;
NOVELTY TOYS, NAMELY, TOY FOAM HANDS, NO-
VELTY FACE MASKS (U.S. CLS. 22, 23, 38 AND 50).

DANNEAN HETZEL, EXAMINING ATTORNEY

CLASS 28—(Continued).

SN 85-235,446. VLOSICH RICHARD T., PRESCOT VALLEY, AZ. FILED 2-7-2011.

Mr. V Putter it rolls

THE MARK CONSISTS OF STANDARD CHARACTERS WITHOUT CLAIM TO ANY PARTICULAR FONT, STYLE, SIZE, OR COLOR.

NO CLAIM IS MADE TO THE EXCLUSIVE RIGHT TO USE "PUTTER", APART FROM THE MARK AS SHOWN. THE NAME(S), PORTRAIT(S), AND/OR SIGNATURE(S) SHOWN IN THE MARK DOES NOT IDENTIFY A PARTICULAR LIVING INDIVIDUAL.

FOR GOLF PUTTERS (U.S. CLS. 22, 23, 38 AND 50).
TINA L. SNAPP, EXAMINING ATTORNEY

SN 85-239,138. NOODLE HEAD, INC., SANTA BARBARA, CA. FILED 2-10-2011.

PAWPARAZZI

THE MARK CONSISTS OF STANDARD CHARACTERS WITHOUT CLAIM TO ANY PARTICULAR FONT, STYLE, SIZE, OR COLOR.

OWNER OF U.S. REG. NOS. 3,467,841 AND 3,955,847.
FOR ACTION FIGURE TOYS; ARTICLES OF CLOTHING FOR TOYS; BENDABLE TOYS; CHILDREN'S MULTIPLE ACTIVITY TOYS; FANTASY CHARACTER TOYS; PLAY HOUSES AND TOY ACCESSORIES THEREFOR; PLUSH TOYS; POSITIONABLE TOY FIGURES; SOFT SCULPTURE PLUSH TOYS; SOFT SCULPTURE TOYS; STUFFED AND PLUSH TOYS; STUFFED TOY ANIMALS; STUFFED TOYS; TOY ANIMALS; TOY ANIMALS AND ACCESSORIES THEREFOR; TOY FIGURES; TOY FURNITURE; TOY HOUSES (U.S. CLS. 22, 23, 38 AND 50).

FIRST USE 7-15-2005; IN COMMERCE 7-15-2005.
KELLY BOULTON, EXAMINING ATTORNEY

CLASS 28—(Continued).

SN 85-244,641. TOYHOUSE MANUFACTURE CO. LTD., DBA PLAYTIME TOYS, DONGGUAN CITY, CHINA, FILED 2-17-2011.



NO CLAIM IS MADE TO THE EXCLUSIVE RIGHT TO USE "POWER RIDERS" AND "TOYS", APART FROM THE MARK AS SHOWN.

THE COLOR(S) BLACK, YELLOW, RED AND WHITE IS/ARE CLAIMED AS A FEATURE OF THE MARK.

THE MARK CONSISTS OF THE WORDING "POWER RIDERS" IN BLACK LETTERS WITH YELLOW AND RED OUTLINING OVER THE WORDING "WE PUT THE POWER IN PLAYTIME" IN BLACK AND TO THE LEFT OF THE DESIGN OF A BLACK STEERING WHEEL WITH WHITE INTERIOR AND WHITE DETAIL BELOW THE WORDING "PLAYTIME TOYS" IN BLACK.

FOR RIDE-ON TOYS (U.S. CLS. 22, 23, 38 AND 50).
BARBARA BROWN, EXAMINING ATTORNEY

SN 85-247,484. MARTHA JO MASSENGILL, TERRELL, TX. FILED 2-21-2011.



OWNER OF U.S. REG. NO. 3,931,750.

THE MARK CONSISTS OF THE WORD "SPINNER" WITH A FIGURE REPRESENTATIVE OF A SPINNING MOTION ABOVE THE "I".

FOR EQUIPMENT SOLD AS A UNIT FOR PLAYING A PARLOUR GAME (U.S. CLS. 22, 23, 38 AND 50).
WILLIAM ROSSMAN, EXAMINING ATTORNEY

SN 85-252,389. JADA GROUP INC., DBA JADA TOYS, CITY OF INDUSTRY, CA. FILED 2-25-2011.

LOPRO

THE MARK CONSISTS OF STANDARD CHARACTERS WITHOUT CLAIM TO ANY PARTICULAR FONT, STYLE, SIZE, OR COLOR.

FOR ELECTRONIC TOY VEHICLES; ELECTRONICALLY OPERATED TOY MOTOR VEHICLES; MODEL TOY VEHICLES; RADIO CONTROLLED TOY VEHICLES; SCALE-MODEL VEHICLES; TOY MODEL KIT CARS; TOY VEHICLES AND ACCESSORIES THEREFOR (U.S. CLS. 22, 23, 38 AND 50).

RUSS HERMAN, EXAMINING ATTORNEY

CLASS 28—(Continued).

SN 85-255,435. KELLY, BRENDAN, DBA KELLY KON-
CEPTS, HAVERTOWN, PA. FILED 3-2-2011.



NO CLAIM IS MADE TO THE EXCLUSIVE RIGHT TO
USE "GAME", APART FROM THE MARK AS SHOWN.
THE COLOR(S) RED, GREEN, BLUE, WHITE, BLACK IS/
ARE CLAIMED AS A FEATURE OF THE MARK.

THE MARK CONSISTS OF A GREEN AND BLACK
CIRCLE SURROUNDS A CENTERED RED AND BLUE
STAR WITH THE WORDS "GAME ON" IN RED AND BLUE
SUPERIMPOSED OVER AND WITHIN THE STAR, WITH A
WHITE INTERIOR BACKGROUND.

FOR PLAYING CARDS AND CARD GAMES (U.S. CLS.
22, 23, 38 AND 50).

WARREN L. OLANDRIA, EXAMINING ATTORNEY

CLASS 28—(Continued).

SN 85-259,190. PRYCE-THOMAS, JOAN, HUMBLE, TX.
FILED 3-6-2011.



NO CLAIM IS MADE TO THE EXCLUSIVE RIGHT TO
USE "TIME", APART FROM THE MARK AS SHOWN.

THE MARK CONSISTS OF A CLOCK DESIGN BETWEEN
THE WORDS "TIME" AND DESIGN.

FOR BATTERY OPERATED ACTION TOYS; CHIL-
DREN'S MULTIPLE ACTIVITY TOYS; CLOCKWORK
TOYS (U.S. CLS. 22, 23, 38 AND 50).

PAUL F. GAST, EXAMINING ATTORNEY

SN 85-257,846. PLASSMART, INC., OTTAWA, ONTARIO,
CANADA, FILED 3-4-2011.

SMART MAT

THE MARK CONSISTS OF STANDARD CHARACTERS
WITHOUT CLAIM TO ANY PARTICULAR FONT, STYLE,
SIZE, OR COLOR.

NO CLAIM IS MADE TO THE EXCLUSIVE RIGHT TO
USE "MAT", APART FROM THE MARK AS SHOWN.

FOR PLAY MATS FOR USE WITH TOY VEHICLES,
ACTION FIGURES AND OTHER SIMILAR TOYS (U.S.
CLS. 22, 23, 38 AND 50).

FIRST USE 6-14-2011; IN COMMERCE 6-14-2011.

KATHLEEN M. VANSTON, EXAMINING ATTORNEY

SN 85-267,554. OCTANE FITNESS, LLC, BROOKLYN PARK,
MN. FILED 3-15-2011.

CROSS CIRCUIT

THE MARK CONSISTS OF STANDARD CHARACTERS
WITHOUT CLAIM TO ANY PARTICULAR FONT, STYLE,
SIZE, OR COLOR.

FOR EXERCISE MACHINE ACCESSORY IN THE
NATURE OF A STRENGTH TRAINING ATTACHMENT
FOR A CARDIOVASCULAR EXERCISE MACHINE (U.S.
CLS. 22, 23, 38 AND 50).

FIRST USE 10-16-2009; IN COMMERCE 10-16-2009.

FRED CARL, EXAMINING ATTORNEY

CLASS 28—(Continued).

SN 85-267,841. WAYNE L. RICH, GOLETA, CA. FILED 3-15-2011.



OWNER OF U.S. REG. NO. 2,471,630.
NO CLAIM IS MADE TO THE EXCLUSIVE RIGHT TO USE "CUSTOM SURFBOARDS", APART FROM THE MARK AS SHOWN.

THE NAME "WAYNE RICH" IDENTIFIES A LIVING INDIVIDUAL WHOSE CONSENT IS OF RECORD.

THE MARK CONSISTS OF A FOUR POINTED STAR SHAPE WITH A CIRCLE APPEARING BEHIND THE STAR WITH A BLACK AND WHITE DESIGN AND THE WORDS "WAYNE RICH" APPEARING HORIZONTALLY AND "CUSTOM SURFBOARDS" APPEARING VERTICALLY INSIDE OF THE STAR DESIGN.

FOR SURFBOARDS; CLOTHING, NAMELY, T-SHIRTS, SWEATERS AND JACKETS, STICKERS (U.S. CLS. 22, 23, 38 AND 50).

FIRST USE 12-31-2002; IN COMMERCE 12-31-2002.
HEATHER SAPP, EXAMINING ATTORNEY

SN 85-269,200. EBONITE HOLDINGS, INC., HOPKINSVILLE, KY. FILED 3-17-2011.

WHITE DOT

THE MARK CONSISTS OF STANDARD CHARACTERS WITHOUT CLAIM TO ANY PARTICULAR FONT, STYLE, SIZE, OR COLOR.

OWNER OF U.S. REG. NO. 1,149,949.
FOR BOWLING BALLS (U.S. CLS. 22, 23, 38 AND 50).
FIRST USE 5-1-2007; IN COMMERCE 5-1-2007.
WILLIAM VERHOSEK, EXAMINING ATTORNEY

CLASS 28—(Continued).

SN 85-269,857. BRIAN KELLY ENTERPRISES LLC, NOTRE DAME, IN. FILED 3-17-2011.

NEXT MAN IN

THE MARK CONSISTS OF STANDARD CHARACTERS WITHOUT CLAIM TO ANY PARTICULAR FONT, STYLE, SIZE, OR COLOR.

OWNER OF U.S. REG. NO. 3,909,104.
FOR TROLLEY BAGS SPECIALLY ADAPTED FOR SPORTS EQUIPMENT; BAGS SPECIALLY ADAPTED FOR SPORTS EQUIPMENT (U.S. CLS. 22, 23, 38 AND 50).
DOMINICK J. SALEMI, EXAMINING ATTORNEY

SN 85-270,601. NICOLAS M LEASON, AGUADILLA, PUERTO RICO, FILED 3-18-2011.



THE MARK CONSISTS OF THE WORD "LIFT" IN A STYLIZED LETTERING WITH AN EAGLE WING UNDERNEATH IT.

FOR BODY BOARDS; KITE BOARDS; KITE HANDLES; KITE LINES; KITE PARTS; KITE REELS; KITE STRING; KITE TAILS; LEASHES FOR SURFBOARDS; PADDLE SURFBOARDS; PADDLES FOR USE WITH SURFBOARDS; SKIM BOARDS; STAND-UP SURF PADDLES; SURFBOARD FINS; SURFBOARD LEASHES; SURFBOARD WAX; SURFBOARDS; WAKE BOARDS (U.S. CLS. 22, 23, 38 AND 50).

JACLYN KIDWELL WALKER, EXAMINING ATTORNEY

SN 85-271,208. ISOBREATHING, INC., DALLAS, TX. FILED 3-18-2011.

W.H.I.P. Board

THE MARK CONSISTS OF STANDARD CHARACTERS WITHOUT CLAIM TO ANY PARTICULAR FONT, STYLE, SIZE, OR COLOR.

NO CLAIM IS MADE TO THE EXCLUSIVE RIGHT TO USE "BOARD", APART FROM THE MARK AS SHOWN.

FOR EXERCISE EQUIPMENT, NAMELY, APPARATUS SIMULATING SINGLE-PADDLE ROWING MOVEMENT (U.S. CLS. 22, 23, 38 AND 50).

JILL PRATER, EXAMINING ATTORNEY

CLASS 28—(Continued).

SN 85-271,323. FITNESS DESIGN GROUP, INC, SANTA MONICA, CA. FILED 3-18-2011.

ADVANTAGE FITNESS PRODUCTS

THE MARK CONSISTS OF STANDARD CHARACTERS WITHOUT CLAIM TO ANY PARTICULAR FONT, STYLE, SIZE, OR COLOR.

OWNER OF U.S. REG. NOS. 3,221,635 AND 3,246,325. NO CLAIM IS MADE TO THE EXCLUSIVE RIGHT TO USE "FITNESS PRODUCTS", APART FROM THE MARK AS SHOWN.

SEC. 2(F).
FOR DUMB-BELLS; DUMBBELL SETS; EXERCISE BALLS; EXERCISE BARS; EXERCISE EQUIPMENT, NAMELY, INFLATABLE BALLS; FITNESS EQUIPMENT, NAMELY, STRAPS USED FOR YOGA AND OTHER FITNESS ACTIVITIES AND FOR CARRYING A YOGA MAT; MEDICINE BALLS; YOGA MATS (U.S. CLS. 22, 23, 38 AND 50).

FIRST USE 11-15-1996; IN COMMERCE 11-15-1996.
RONALD AIKENS, EXAMINING ATTORNEY

SN 85-271,371. FITNESS DESIGN GROUP, INC, SANTA MONICA, CA. FILED 3-18-2011.

ADVANTAGE

THE MARK CONSISTS OF STANDARD CHARACTERS WITHOUT CLAIM TO ANY PARTICULAR FONT, STYLE, SIZE, OR COLOR.

OWNER OF U.S. REG. NOS. 3,221,635 AND 3,246,325. SEC. 2(F).
FOR DUMB-BELLS; DUMBBELL SETS; EXERCISE BALLS; EXERCISE BARS; EXERCISE EQUIPMENT, NAMELY, INFLATABLE BALLS; FITNESS EQUIPMENT, NAMELY, STRAPS USED FOR YOGA AND OTHER FITNESS ACTIVITIES AND FOR CARRYING A YOGA MAT; MEDICINE BALLS; YOGA MATS (U.S. CLS. 22, 23, 38 AND 50).

FIRST USE 11-15-1996; IN COMMERCE 11-15-1996.
RONALD AIKENS, EXAMINING ATTORNEY

CLASS 28—(Continued).

SN 85-271,499. BALL UP, LLC, FORT WORTH, TX. FILED 3-19-2011.

PROSBL

THE MARK CONSISTS OF STANDARD CHARACTERS WITHOUT CLAIM TO ANY PARTICULAR FONT, STYLE, SIZE, OR COLOR.

FOR TOYS AND SPORTING GOODS, NAMELY, BASKETBALLS, GOLF BALLS, PLAYGROUND BALLS, SPORTS BALLS, RUBBER ACTION BALLS AND FOAM ACTION BALLS, BASKETBALL NETS, BASKETBALL BACKBOARDS, PUMPS FOR INFLATING BASKETBALLS AND NEEDLES THEREFOR, GOLF CLUBS, GOLF BAGS, ELECTRONIC BASKETBALL TABLE TOP GAMES, STAND-ALONE VIDEO GAME MACHINES, BASKETBALL TABLE TOP GAMES, BASKETBALL BOARD GAMES, ELECTRONIC VIDEO ARCADE GAME MACHINES, BASKETBALL KIT COMPRISED OF A BASKETBALL NET AND WHISTLE, DOLLS, STUFFED TOYS, JIGSAW PUZZLES AND CHRISTMAS TREE ORNAMENTS (U.S. CLS. 22, 23, 38 AND 50).

ROBIN CHOSID, EXAMINING ATTORNEY

SN 85-271,877. SENARIO LLC, WOODSTOCK, IL. FILED 3-21-2011.

Little Emu

THE MARK CONSISTS OF STANDARD CHARACTERS WITHOUT CLAIM TO ANY PARTICULAR FONT, STYLE, SIZE, OR COLOR.

NO CLAIM IS MADE TO THE EXCLUSIVE RIGHT TO USE "EMU", APART FROM THE MARK AS SHOWN.

FOR TOY ANIMALS (U.S. CLS. 22, 23, 38 AND 50).
ELI HELLMAN, EXAMINING ATTORNEY

SN 85-271,883. SENARIO LLC, WOODSTOCK, IL. FILED 3-21-2011.

Little Keko

THE MARK CONSISTS OF STANDARD CHARACTERS WITHOUT CLAIM TO ANY PARTICULAR FONT, STYLE, SIZE, OR COLOR.

NO CLAIM IS MADE TO THE EXCLUSIVE RIGHT TO USE "KEKO", APART FROM THE MARK AS SHOWN.

THE ENGLISH TRANSLATION OF "KEKO" IN THE MARK IS "MONKEY" OR "APE".
FOR TOY ANIMALS (U.S. CLS. 22, 23, 38 AND 50).
ELI HELLMAN, EXAMINING ATTORNEY

CLASS 28—(Continued).

SN 85-272,072. MILLER, DAVID, DALLAS, TX. FILED 3-21-2011.

FLIIP FOOTBALL

THE MARK CONSISTS OF STANDARD CHARACTERS WITHOUT CLAIM TO ANY PARTICULAR FONT, STYLE, SIZE, OR COLOR.

NO CLAIM IS MADE TO THE EXCLUSIVE RIGHT TO USE "FOOTBALL", APART FROM THE MARK AS SHOWN. FOR CARD GAMES (U.S. CLS. 22, 23, 38 AND 50). FLORENTINA BLANDU, EXAMINING ATTORNEY

SN 85-272,893. TIBBETTS, KIRSTEN, GOLF, IL. FILED 3-21-2011.

Original DreamPuffs

THE MARK CONSISTS OF STANDARD CHARACTERS WITHOUT CLAIM TO ANY PARTICULAR FONT, STYLE, SIZE, OR COLOR.

NO CLAIM IS MADE TO THE EXCLUSIVE RIGHT TO USE "ORIGINAL", APART FROM THE MARK AS SHOWN. FOR TOYS, NAMELY, CHILDREN'S DRESS-UP ACCESSORIES (U.S. CLS. 22, 23, 38 AND 50). BARBARA RUTLAND, EXAMINING ATTORNEY

SN 85-272,976. CONFIDENCE BAIT, LLC, FREDERICK, MD. FILED 3-22-2011.

BELLY BUTTON WEIGHT

THE MARK CONSISTS OF STANDARD CHARACTERS WITHOUT CLAIM TO ANY PARTICULAR FONT, STYLE, SIZE, OR COLOR.

NO CLAIM IS MADE TO THE EXCLUSIVE RIGHT TO USE "WEIGHT", APART FROM THE MARK AS SHOWN. FOR FISHING WEIGHTS (U.S. CLS. 22, 23, 38 AND 50). ELLEN BURNS, EXAMINING ATTORNEY

CLASS 28—(Continued).

SN 85-273,155. SEARS BRANDS, LLC, HOFFMAN ESTATES, IL. FILED 3-22-2011.

WINTERS NIGHT

THE MARK CONSISTS OF STANDARD CHARACTERS WITHOUT CLAIM TO ANY PARTICULAR FONT, STYLE, SIZE, OR COLOR.

FOR ARTIFICIAL CHRISTMAS GARLANDS; ARTIFICIAL CHRISTMAS WREATHS; PRE-LIT ARTIFICIAL CHRISTMAS GARLANDS; PRE-LIT ARTIFICIAL CHRISTMAS WREATHS; CHRISTMAS TREE ORNAMENTS; CHRISTMAS TREE DECORATIONS, NAMELY, TREE TOPPERS; CHRISTMAS TREE DECORATIONS; CHRISTMAS TREE SKIRTS; CHRISTMAS STOCKINGS; TINSEL FOR CHRISTMAS TREES (U.S. CLS. 22, 23, 38 AND 50).

FIRST USE 10-0-2010; IN COMMERCE 10-0-2010. ELIZABETH HUGHITT, EXAMINING ATTORNEY

SN 85-273,986. SCHANTANK SKATEBOARDS, DELRAY BEACH, FL. FILED 3-22-2011.

Schantank Skateboards

THE MARK CONSISTS OF STANDARD CHARACTERS WITHOUT CLAIM TO ANY PARTICULAR FONT, STYLE, SIZE, OR COLOR.

NO CLAIM IS MADE TO THE EXCLUSIVE RIGHT TO USE "SKATEBOARDS", APART FROM THE MARK AS SHOWN.

FOR SKATEBOARD DECKS (U.S. CLS. 22, 23, 38 AND 50).

FIRST USE 6-20-2008; IN COMMERCE 6-20-2008. SAMUEL E. SHARPER JR., EXAMINING ATTORNEY

SN 85-274,002. PATCH PRODUCTS, INC., BELOIT, WI. FILED 3-22-2011.

Cap Toys

THE MARK CONSISTS OF STANDARD CHARACTERS WITHOUT CLAIM TO ANY PARTICULAR FONT, STYLE, SIZE, OR COLOR.

NO CLAIM IS MADE TO THE EXCLUSIVE RIGHT TO USE "TOYS", APART FROM THE MARK AS SHOWN.

FOR BUBBLE MAKING WAND AND SOLUTION SETS (U.S. CLS. 22, 23, 38 AND 50).

CHERYL CLAYTON, EXAMINING ATTORNEY

CLASS 28—(Continued).

SN 85-274,042. GOLD CIRCLE VIDEO & DIGITAL SERVICES LLC, VISTA, CA. FILED 3-22-2011.

**STRENGTH AND COACHING
REACTOR**

NO CLAIM IS MADE TO THE EXCLUSIVE RIGHT TO USE "STRENGTH AND COACHING", APART FROM THE MARK AS SHOWN.

THE MARK CONSISTS OF THE STYLIZED TEXT "STRENGTH AND COACHING REACTOR".

FOR SPORTS TRAINING APPARATUS, NAMELY, A DIRECTIONAL LIGHTED DEVICE THAT SIGNALS A DIRECTION AN ATHLETE MUST MOVE TOWARD FROM A STANDING POSITION (U.S. CLS. 22, 23, 38 AND 50).

TAMARA FRAZIER, EXAMINING ATTORNEY

SN 85-274,159. ZING TOYS, INC., BANKS, OR. FILED 3-23-2011.

BENDA' BLASTER

THE MARK CONSISTS OF STANDARD CHARACTERS WITHOUT CLAIM TO ANY PARTICULAR FONT, STYLE, SIZE, OR COLOR.

NO CLAIM IS MADE TO THE EXCLUSIVE RIGHT TO USE "BLASTER", APART FROM THE MARK AS SHOWN.

FOR TOY GUNS; TOY PISTOLS; TOY WEAPONS (U.S. CLS. 22, 23, 38 AND 50).

FIRST USE 1-1-2011; IN COMMERCE 1-1-2011.

JENNY PARK, EXAMINING ATTORNEY

SN 85-274,444. ZING TOYS, INC., BANKS, OR. FILED 3-23-2011.

ZX CROSS-BOW

THE MARK CONSISTS OF STANDARD CHARACTERS WITHOUT CLAIM TO ANY PARTICULAR FONT, STYLE, SIZE, OR COLOR.

NO CLAIM IS MADE TO THE EXCLUSIVE RIGHT TO USE "CROSS-BOW", APART FROM THE MARK AS SHOWN.

FOR ARROWS; TOY BOWS AND ARROWS; TOY WEAPONS (U.S. CLS. 22, 23, 38 AND 50).

FIRST USE 1-1-2011; IN COMMERCE 1-1-2011.

JENNY PARK, EXAMINING ATTORNEY

CLASS 28—(Continued).

SN 85-274,561. ZING TOYS, INC., BANKS, OR. FILED 3-23-2011.

ZIP-BAK BOW

THE MARK CONSISTS OF STANDARD CHARACTERS WITHOUT CLAIM TO ANY PARTICULAR FONT, STYLE, SIZE, OR COLOR.

NO CLAIM IS MADE TO THE EXCLUSIVE RIGHT TO USE "BOW", APART FROM THE MARK AS SHOWN.

FOR ARROWS; TOY BOWS AND ARROWS; TOY WEAPONS (U.S. CLS. 22, 23, 38 AND 50).

FIRST USE 1-1-2011; IN COMMERCE 1-1-2011.

JENNY PARK, EXAMINING ATTORNEY

SN 85-274,872. PATCH PRODUCTS, INC., BELOIT, WI. FILED 3-23-2011.

Farkle Fanatic

THE MARK CONSISTS OF STANDARD CHARACTERS WITHOUT CLAIM TO ANY PARTICULAR FONT, STYLE, SIZE, OR COLOR.

NO CLAIM IS MADE TO THE EXCLUSIVE RIGHT TO USE "FARKLE", APART FROM THE MARK AS SHOWN.

FOR DICE GAMES (U.S. CLS. 22, 23, 38 AND 50).

CHERYL CLAYTON, EXAMINING ATTORNEY

SN 85-275,216. VAZQUEZ, DAVID, DBA LURKVILLE, USA, SAN DIEGO, CA. AND VAZQUEZ, JULIAN, DBA LURKVILLE, USA, SAN DIEGO, CA. AND TAYLOR, TYRONE, DBA LURKVILLE, USA, SAN DIEGO, CA. FILED 3-24-2011.

**LURKVILLE!
USA**

NO CLAIM IS MADE TO THE EXCLUSIVE RIGHT TO USE "USA", APART FROM THE MARK AS SHOWN.

THE MARK CONSISTS OF STYLIZED FONT OF "LURKVILLE, USA" WITH AN EXCLAMATION MARK AT THE END OF "LURKVILLE".

FOR SKATEBOARD DECKS (U.S. CLS. 22, 23, 38 AND 50).

FIRST USE 11-15-2010; IN COMMERCE 11-15-2010.

DORITT L. CARROLL, EXAMINING ATTORNEY

CLASS 28—(Continued).

SN 85-275,396. LUCAS, JAMES O., ST. AUGUSTINE, FL. FILED 3-24-2011.

PLAYERS

THE MARK CONSISTS OF STANDARD CHARACTERS WITHOUT CLAIM TO ANY PARTICULAR FONT, STYLE, SIZE, OR COLOR.

OWNER OF U.S. REG. NOS. 2,255,758 AND 3,477,564. SEC. 2(F).
FOR BILLIARD CUES; POOL CUE CASES; POOL CUES (U.S. CLS. 22, 23, 38 AND 50).
FIRST USE 6-0-1991; IN COMMERCE 6-0-1991.
CARRIE GENOVESE, EXAMINING ATTORNEY

SN 85-275,806. DIANE POLICASRO, BAYONNE, NJ. FILED 3-24-2011.

P  **L GURU INC**

NO CLAIM IS MADE TO THE EXCLUSIVE RIGHT TO USE "POOL" AND "INC", APART FROM THE MARK AS SHOWN.

THE COLOR(S) YELLOW, BLACK, GRAY AND WHITE IS/ARE CLAIMED AS A FEATURE OF THE MARK.

THE MARK CONSISTS OF THE WORD "POOL". THE TWO LETTER "O"'S IN "POOL" ARE FORMED BY A BILLIARD BALL IN YELLOW, WHITE AND GRAY WITH THE NUMBER "9" IN BLACK AND A BILLIARD BALL IN BLACK AND WHITE WITH THE NUMBER "8" IN BLACK. THE LETTERS "P" AND "L" IN "POOL" AND "GURU INC" ARE IN BLACK.

FOR BILLIARD GAME PLAYING EQUIPMENT; BILLIARD TALLY BALLS; CHALK FOR BILLIARD CUES (U.S. CLS. 22, 23, 38 AND 50).

EDWARD NELSON, EXAMINING ATTORNEY

SN 85-275,808. DIANE POLICASRO, BAYONNE, NJ. FILED 3-24-2011.

POOL GURU

THE MARK CONSISTS OF STANDARD CHARACTERS WITHOUT CLAIM TO ANY PARTICULAR FONT, STYLE, SIZE, OR COLOR.

NO CLAIM IS MADE TO THE EXCLUSIVE RIGHT TO USE "POOL", APART FROM THE MARK AS SHOWN.

FOR BILLIARD GAME PLAYING EQUIPMENT; BILLIARD TALLY BALLS; CHALK FOR BILLIARD CUES (U.S. CLS. 22, 23, 38 AND 50).

EDWARD NELSON, EXAMINING ATTORNEY

CLASS 28—(Continued).

SN 85-276,068. SHOOT THE MOON PRODUCTS II, LLC, PLEASANTON, CA. FILED 3-24-2011.

DAISY CLOVER

THE MARK CONSISTS OF STANDARD CHARACTERS WITHOUT CLAIM TO ANY PARTICULAR FONT, STYLE, SIZE, OR COLOR.

FOR DOLLS AND ACCESSORIES THEREFOR; PLAYSETS FOR DOLLS (U.S. CLS. 22, 23, 38 AND 50).
GEOFFREY FOSDICK, EXAMINING ATTORNEY

SN 85-276,619. SQWISHLAND, LLC, SCOTTSDALE, AZ. FILED 3-25-2011.

IF IT'S SOFT 'N SQUISHY, IT
BELONGS IN SQWISHLAND!

THE MARK CONSISTS OF STANDARD CHARACTERS WITHOUT CLAIM TO ANY PARTICULAR FONT, STYLE, SIZE, OR COLOR.

OWNER OF U.S. REG. NO. 3,872,820.
FOR ATTACHABLE, WEARABLE, MAGNETIC TOY FIGURINES; MOLDED TOY FIGURES; PLASTIC CHARACTER TOYS; RUBBER CHARACTER TOYS; TOY ANIMALS; TOY FIGURES (U.S. CLS. 22, 23, 38 AND 50).
FIRST USE 1-20-2011; IN COMMERCE 1-20-2011.
MATTHEW MCDOWELL, EXAMINING ATTORNEY

SN 85-277,111. ARMADILLO BRAND, INC., LUMBERTON, TX. FILED 3-25-2011.

ROCKLAND OUTDOORS

THE MARK CONSISTS OF STANDARD CHARACTERS WITHOUT CLAIM TO ANY PARTICULAR FONT, STYLE, SIZE, OR COLOR.

NO CLAIM IS MADE TO THE EXCLUSIVE RIGHT TO USE "OUTDOORS", APART FROM THE MARK AS SHOWN.

FOR FISHING TACKLE, ANIMAL HUNTING DECOYS, FISHING FLOATS (U.S. CLS. 22, 23, 38 AND 50).
FIRST USE 10-7-2009; IN COMMERCE 10-7-2009.

HOWARD B. LEVINE, EXAMINING ATTORNEY

CLASS 28—(Continued).

SN 85-279,375. LITTLE KIDS, INC., SEEKONK, MA. FILED 3-29-2011.

SOAK 'N SPLASH

THE MARK CONSISTS OF STANDARD CHARACTERS WITHOUT CLAIM TO ANY PARTICULAR FONT, STYLE, SIZE, OR COLOR.

FOR WATER TOYS; WATER SLIDES; WATER SHOOTING TOYS; TOY WATER SPRINKLERS; SWIMMING POOL TOYS, TOY BALLOONS; PUMPS FOR INFLATING TOY BALLOONS; PADDLE BALLS; PADDLES FOR USE IN PADDLE BALL GAMES; BATS FOR GAMES; BALLS FOR GAMES (U.S. CLS. 22, 23, 38 AND 50).

GENE MACIOL, EXAMINING ATTORNEY

CLASS 28—(Continued).

SN 85-286,474. CALLAWAY GOLF COMPANY, CARLSBAD, CA. FILED 4-5-2011.

Through The Bag Technology

THE MARK CONSISTS OF STANDARD CHARACTERS WITHOUT CLAIM TO ANY PARTICULAR FONT, STYLE, SIZE, OR COLOR.

NO CLAIM IS MADE TO THE EXCLUSIVE RIGHT TO USE "TECHNOLOGY", APART FROM THE MARK AS SHOWN.

FOR GOLF BALLS (U.S. CLS. 22, 23, 38 AND 50).

BARBARA A. GOLD, EXAMINING ATTORNEY

SN 85-280,546. MATTEL, INC., EL SEGUNDO, CA. FILED 3-29-2011.

RING BLASTERS

THE MARK CONSISTS OF STANDARD CHARACTERS WITHOUT CLAIM TO ANY PARTICULAR FONT, STYLE, SIZE, OR COLOR.

NO CLAIM IS MADE TO THE EXCLUSIVE RIGHT TO USE "RING", APART FROM THE MARK AS SHOWN.

FOR ROLE PLAY TOY RINGS WORN BY CHILDREN AND HAVING LIGHT AND SOUND FEATURES (U.S. CLS. 22, 23, 38 AND 50).

ASMAT KHAN, EXAMINING ATTORNEY

SN 85-291,074. HOWARD NOLEN, DBA ITG SLYDER FOOTBALL, LEECHBURG, PA. FILED 4-9-2011.

SLYDER FOOTBALL

THE MARK CONSISTS OF STANDARD CHARACTERS WITHOUT CLAIM TO ANY PARTICULAR FONT, STYLE, SIZE, OR COLOR.

NO CLAIM IS MADE TO THE EXCLUSIVE RIGHT TO USE "FOOTBALL", APART FROM THE MARK AS SHOWN.

FOR ACTION SKILL GAMES; TABLETOP GAMES (U.S. CLS. 22, 23, 38 AND 50).

FIRST USE 11-29-2010; IN COMMERCE 11-29-2010.

CARYN GLASSER, EXAMINING ATTORNEY

SN 85-286,408. ANDREA M. GRISWELL, STONE MOUNTAIN, GA. FILED 4-5-2011.

THE 21ST CENTURY TEDDY BEAR

THE MARK CONSISTS OF STANDARD CHARACTERS WITHOUT CLAIM TO ANY PARTICULAR FONT, STYLE, SIZE, OR COLOR.

NO CLAIM IS MADE TO THE EXCLUSIVE RIGHT TO USE "TEDDY BEAR", APART FROM THE MARK AS SHOWN.

FOR TOYS, NAMELY, PLUSH DOLLS (U.S. CLS. 22, 23, 38 AND 50).

TIMOTHY FINNEGAN, EXAMINING ATTORNEY

SN 85-291,345. EXEMPLAR DESIGN, LLC, CINCINNATI, OH. FILED 4-11-2011.



THE MARK CONSISTS OF A SHARK WITH AN OPEN MOUTH, A DARK UPPER SURFACE, AND A LIGHT LOWER SURFACE.

FOR AEROBIC STEPS; EXERCISE EQUIPMENT, NAMELY, HURDLES, PULL-UP BARS, SUSPENSION BARS FOR ATTACHING RESISTANCE BANDS, RESISTANCE BANDS; EXERCISE WEIGHTS; MEDICINE BALLS (U.S. CLS. 22, 23, 38 AND 50).

GEOFFREY FOSDICK, EXAMINING ATTORNEY

CLASS 28—(Continued).

SN 85-291,418. APPEL, STEPHEN W., MANASQUAN, NJ. FILED 4-11-2011.

chikwax

THE MARK CONSISTS OF STANDARD CHARACTERS WITHOUT CLAIM TO ANY PARTICULAR FONT, STYLE, SIZE, OR COLOR.

FOR SURFBOARD WAX (U.S. CLS. 22, 23, 38 AND 50).
FRANK LATTUCA, EXAMINING ATTORNEY

CLASS 28—(Continued).

SN 85-291,591. COMO, KENNETH, SUNNYSIDE, NY. FILED 4-11-2011.

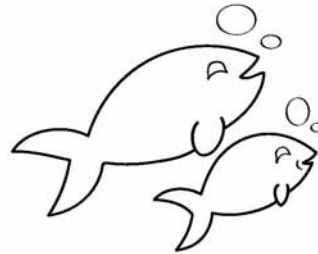

THE MARK CONSISTS OF TWO FISH. ONE LARGE SWIMMING OVER A SMALLER FISH. EACH FISH HAS TWO BUBBLES OVER THEIR HEAD.

FOR WOODEN TOY ROBOTS; WOODEN TOY CARS; WOODEN TOY BABY RATTLES (U.S. CLS. 22, 23, 38 AND 50).

FIRST USE 10-1-2010; IN COMMERCE 10-1-2010.
ESTHER A. BORSUK, EXAMINING ATTORNEY

SN 85-291,628. ANGLER INNOVATIONS, ORLANDO, FL. FILED 4-11-2011.

SN 85-291,423. L & M FISHERIES, INC., POMPANO BEACH, FL. FILED 4-11-2011.



Rod Jacket

THE MARK CONSISTS OF STANDARD CHARACTERS WITHOUT CLAIM TO ANY PARTICULAR FONT, STYLE, SIZE, OR COLOR.

NO CLAIM IS MADE TO THE EXCLUSIVE RIGHT TO USE "ROD", APART FROM THE MARK AS SHOWN.
FOR FISHING ROD CASES (U.S. CLS. 22, 23, 38 AND 50).

FIRST USE 1-10-2010; IN COMMERCE 1-10-2010.
ANDREW LEASER, EXAMINING ATTORNEY

SN 85-291,762. KOLLER ENTERPRISES, INC., DBA HAWKEYE INTERNATIONAL, SHAWNEE, KS. FILED 4-11-2011.

POOCH PULL

THE COLOR(S) RED, WHITE AND BLACK IS/ARE CLAIMED AS A FEATURE OF THE MARK.

THE MARK CONSISTS OF A CIRCLE SUBDIVIDED IN BLACK AND RED PORTIONS WITH A PRIMARILY WHITE FISH WITH BLACK LINES THAT CONTAINS A SMALL RED RECTANGLE OVER THE CIRCLE.

FOR ARTIFICIAL FISHING BAIT; ARTIFICIAL FISHING LURES; FISHING LURES; FISHING TACKLE (U.S. CLS. 22, 23, 38 AND 50).

FIRST USE 5-0-1996; IN COMMERCE 5-0-1996.
GEORGE LORENZO, EXAMINING ATTORNEY

THE MARK CONSISTS OF STANDARD CHARACTERS WITHOUT CLAIM TO ANY PARTICULAR FONT, STYLE, SIZE, OR COLOR.

OWNER OF U.S. REG. NO. 3,072,257.
NO CLAIM IS MADE TO THE EXCLUSIVE RIGHT TO USE "PULL", APART FROM THE MARK AS SHOWN.
SEC. 2(F) AS TO "POOCH PULL".

FOR DOG TOYS (U.S. CLS. 22, 23, 38 AND 50).
FIRST USE 6-0-2004; IN COMMERCE 11-0-2004.

TRACY FLETCHER, EXAMINING ATTORNEY

CLASS 28—(Continued).

SN 85-291,868. TENACIOUS TOYZ, LLC, PARK CITY, UT. FILED 4-11-2011.

PARK ZARZ

THE MARK CONSISTS OF STANDARD CHARACTERS WITHOUT CLAIM TO ANY PARTICULAR FONT, STYLE, SIZE, OR COLOR.

FOR ACTION FIGURES; ACTION FIGURES AND ACCESSORIES THEREFOR; CASES FOR ACTION FIGURES; COLLECTABLE TOY FIGURES; PLAY SETS FOR ACTION FIGURES; POSITIONABLE TOY FIGURES (U.S. CLS. 22, 23, 38 AND 50).

CAROLINE WOOD, EXAMINING ATTORNEY

SN 85-291,966. PRIMEEVIL LURE, INC., METTAWA, IL. FILED 4-11-2011.



THE MARK CONSISTS OF THE WORD "PRIMEEVIL" AND A FISH WITH JAGGED TEETH IN THE JAW AND WITH A JAGGED FIN ON THE TOP, WITH THE TAIL OF THE FISH BEING A PART OF LETTER "V" IN THE WORD "PRIMEEVIL".

FOR FISHING EQUIPMENT, NAMELY, FISHING LURES (U.S. CLS. 22, 23, 38 AND 50).

DAVID I, EXAMINING ATTORNEY

SN 85-292,094. MYFORTBOX, LLC, DBA MYFORTBOX, PROVO, UT. FILED 4-11-2011.

The Tower of London

THE MARK CONSISTS OF STANDARD CHARACTERS WITHOUT CLAIM TO ANY PARTICULAR FONT, STYLE, SIZE, OR COLOR.

THE WORDING "THE TOWER OF LONDON" HAS NO MEANING IN A FOREIGN LANGUAGE.

FOR PLAY HOUSES (U.S. CLS. 22, 23, 38 AND 50). FIRST USE 12-8-2009; IN COMMERCE 11-19-2010.

TOBY BULLOFF, EXAMINING ATTORNEY

CLASS 28—(Continued).

SN 85-292,186. COMFITPRO PTY LTD, ALEXANDRIA NSW 2015, AUSTRALIA, FILED 4-11-2011.



OWNER OF U.S. REG. NOS. 3,426,981 AND 3,432,703. NO CLAIM IS MADE TO THE EXCLUSIVE RIGHT TO USE "MADE BY", APART FROM THE MARK AS SHOWN.

THE MARK CONSISTS OF THE WORDING "AEROBOWLS" ON ONE LINE WITH THE WORDING "MADE BY COMFITPRO" ON THE LINE BELOW. A DESIGN OF A HIGHLY STYLIZED BALL WITH AN ABSTRACT FLARING DESIGN TO GIVE THE IMPRESSION OF MOVEMENT IS ABOVE THE WORD "AEROBOWLS". THE MARK APPEARS INSIDE A RECTANGLE.

FOR SPORTING GOODS IN THE NATURE OF LAWN BOWLS EQUIPMENT AND APPARATUS, NAMELY, BOWLING BALLS, BOWLS BAGS (U.S. CLS. 22, 23, 38 AND 50).

CHRISTINE COOPER, EXAMINING ATTORNEY

SN 85-292,378. FLOPPY DISC ROYALTY CORP., BOULDER, CO. FILED 4-12-2011.

SMALL FRY

THE MARK CONSISTS OF STANDARD CHARACTERS WITHOUT CLAIM TO ANY PARTICULAR FONT, STYLE, SIZE, OR COLOR.

FOR DISC TOSS TOYS (U.S. CLS. 22, 23, 38 AND 50). FIRST USE 10-11-1991; IN COMMERCE 10-11-1991.

GEORGE LORENZO, EXAMINING ATTORNEY

SN 85-292,408. IMAGINATION HOLDINGS PTY LTD, ADELAIDE, AUSTRALIA, FILED 4-12-2011.



THE MARK CONSISTS OF THE WORD "KA'LIDE" WITH THE APOSTROPHE REPRESENTED BY A LIGHTNING BOLT.

FOR TOYS, PLAYTHINGS AND GAMES, NAMELY, BOARD GAMES, PARTY GAMES AND PARLOR GAMES AND COMPONENT PIECES THEREOF FOR USE AS A SET AND SOLD AS A UNIT THEREWITH FOR PLAYING SUCH GAMES (U.S. CLS. 22, 23, 38 AND 50).

DAVID H. STINE, EXAMINING ATTORNEY

CLASS 28—(Continued).

SN 85-292,475. INNEGRITY, SIMPSONVILLE, SC. FILED 4-12-2011.

INNEGRA

THE MARK CONSISTS OF STANDARD CHARACTERS WITHOUT CLAIM TO ANY PARTICULAR FONT, STYLE, SIZE, OR COLOR.

OWNER OF U.S. REG. NOS. 3,792,471, 3,792,472 AND 3,792,473.

FOR TENNIS RACQUETS, BASEBALL BATS, CRICKET BATS, GOLF CLUBS AND HOCKEY STICKS (U.S. CLS. 22, 23, 38 AND 50).

FIRST USE 3-31-2010; IN COMMERCE 10-31-2010.
EMILY CARLSEN, EXAMINING ATTORNEY

CLASS 28—(Continued).

SN 85-293,386. MATTEL, INC., EL SEGUNDO, CA. FILED 4-12-2011.

PERIL PEAK

THE MARK CONSISTS OF STANDARD CHARACTERS WITHOUT CLAIM TO ANY PARTICULAR FONT, STYLE, SIZE, OR COLOR.

FOR TOY VEHICLE PLAYSETS AND ACCESSORIES THEREFOR (U.S. CLS. 22, 23, 38 AND 50).

DOMINIC FATHY, EXAMINING ATTORNEY

SN 85-292,533. B FIT, LLC, GRAND HAVEN, MI. FILED 4-12-2011.



THE MARK CONSISTS OF THE WORD "BEACHFIT" WHEREIN THE "B" COMPRISES A RUNNING FIGURE.

FOR EXERCISE BALLS; EXERCISE EQUIPMENT, NAMELY, A SPECIALIZED DEVICE FOR DIGGING IN SAND; FLYING DISCS (U.S. CLS. 22, 23, 38 AND 50).

JORDAN BAKER, EXAMINING ATTORNEY

SN 85-293,387. MATTEL, INC., EL SEGUNDO, CA. FILED 4-12-2011.

SHELLCASTER

THE MARK CONSISTS OF STANDARD CHARACTERS WITHOUT CLAIM TO ANY PARTICULAR FONT, STYLE, SIZE, OR COLOR.

FOR TOY ACTION FIGURES AND ACCESSORIES THEREFOR; BOARD GAMES AND PARLOR GAMES (U.S. CLS. 22, 23, 38 AND 50).

DOMINIC FATHY, EXAMINING ATTORNEY

SN 85-292,690. LANNY JOHNSON, OKEMOS, OH. FILED 4-12-2011.

SYNAPSE

THE MARK CONSISTS OF STANDARD CHARACTERS WITHOUT CLAIM TO ANY PARTICULAR FONT, STYLE, SIZE, OR COLOR.

FOR GOLF CLUB GRIPS (U.S. CLS. 22, 23, 38 AND 50).
JAY BESCH, EXAMINING ATTORNEY

SN 85-293,389. MATTEL, INC., EL SEGUNDO, CA. FILED 4-12-2011.

SHELLCASTERS

THE MARK CONSISTS OF STANDARD CHARACTERS WITHOUT CLAIM TO ANY PARTICULAR FONT, STYLE, SIZE, OR COLOR.

FOR TOY ACTION FIGURES AND ACCESSORIES THEREFOR; BOARD GAMES AND PARLOR GAMES (U.S. CLS. 22, 23, 38 AND 50).

DOMINIC FATHY, EXAMINING ATTORNEY

CLASS 28—(Continued).

SN 85-293,463. NORTH AMERICAN SOCCER LEAGUE, LLC, MIAMI, FL. FILED 4-12-2011.

NASL

THE MARK CONSISTS OF STANDARD CHARACTERS WITHOUT CLAIM TO ANY PARTICULAR FONT, STYLE, SIZE, OR COLOR.

FOR SOCCER BALLS (U.S. CLS. 22, 23, 38 AND 50).
BRENDAN MCCAULEY, EXAMINING ATTORNEY

SN 85-293,498. BILLITTI, JOSEPH W, OAKHURST, CA. FILED 4-12-2011.

DETOURS

THE MARK CONSISTS OF THE STYLIZED TEXT "DETOURS" WITH TWO SETS OF CURVED DIRECTIONAL ARROWS THROUGH THE "O".

FOR BOARD GAMES (U.S. CLS. 22, 23, 38 AND 50).
JUDITH HELFMAN, EXAMINING ATTORNEY

SN 85-294,173. THOSE CHARACTERS FROM CLEVELAND, INC., CLEVELAND, OH. FILED 4-13-2011.

BUTTER COOKIE

THE MARK CONSISTS OF STANDARD CHARACTERS WITHOUT CLAIM TO ANY PARTICULAR FONT, STYLE, SIZE, OR COLOR.

FOR PLUSH TOYS; TOY ACTION FIGURES AND ACCESSORIES THEREFOR (U.S. CLS. 22, 23, 38 AND 50).
DOMINICK J. SALEMI, EXAMINING ATTORNEY

CLASS 28—(Continued).

SN 85-294,568. MUELLER, ANDREW T., DBA THE QUIET LIFE, LOS ANGELES, CA. FILED 4-13-2011.

THE QUIET LIFE

THE MARK CONSISTS OF STANDARD CHARACTERS WITHOUT CLAIM TO ANY PARTICULAR FONT, STYLE, SIZE, OR COLOR.

FOR TOYS AND SPORTING GOODS, NAMELY, SKATEBOARDS, SNOWBOARDS, SURFBOARDS, WAKEBOARDS, LONGBOARDS, ROLLER SKATES, IN-LINE SKATES, LEASHES FOR SURFBOARDS, BAGS FOR SKATEBOARDS, BAGS SPECIALLY DESIGNED FOR SNOWBOARDS, BAGS SPECIALLY DESIGNED FOR SURFBOARDS, GOLF BAGS, DART CARRYING CASES, TABLE TENNIS BALLS, TABLE TENNIS PADDLES, TABLE TENNIS PADDLE CASES, TABLE TENNIS TABLES, TENNIS RACKETS, TENNIS RACKET COVERS, TENNIS BALLS, BADMINTON SETS, SOCCER BALLS, GOLF BALLS, BASEBALLS, BASEBALL BATS, BASEBALL GLOVES, BOXING GLOVES, KARATE HEAD GUARDS, TOY FIGURES, COLLECTABLE TOY FIGURES, ACTION FIGURES, DOLLS, BOBBLEHEAD DOLLS, TEDDY BEARS, MECHANICAL TOYS, BABY RATTLES, BALLOONS, KITES, PAINTBALL GUNS, PET TOYS, AND YOGA MATS (U.S. CLS. 22, 23, 38 AND 50).
FIRST USE 2-1-1997; IN COMMERCE 7-27-1997.
ALEX KEAM, EXAMINING ATTORNEY

SN 85-294,836. GLOBERIDE, INC., TOKYO, JAPAN, FILED 4-14-2011.

MADDRAGON

THE MARK CONSISTS OF STANDARD CHARACTERS WITHOUT CLAIM TO ANY PARTICULAR FONT, STYLE, SIZE, OR COLOR.

FOR FISHING RODS (U.S. CLS. 22, 23, 38 AND 50).
MICHAEL WEBSTER, EXAMINING ATTORNEY

SN 85-295,234. CORN-FUSION LLC, ROCK HILL, SC. FILED 4-14-2011.

DON'T FEED 'EM, CORN-FUSE 'EM

THE MARK CONSISTS OF STANDARD CHARACTERS WITHOUT CLAIM TO ANY PARTICULAR FONT, STYLE, SIZE, OR COLOR.

FOR SCENTED DEER ATTRACTANT (U.S. CLS. 22, 23, 38 AND 50).
FIRST USE 8-21-2009; IN COMMERCE 8-21-2009.
ERIN FALK, EXAMINING ATTORNEY

CLASS 28—(Continued).

SN 85-295,240. CORN-FUSION LLC, ROCK HILL, SC. FILED 4-14-2011.

LIKE A CORN FIELD IN A BOTTLE

THE MARK CONSISTS OF STANDARD CHARACTERS WITHOUT CLAIM TO ANY PARTICULAR FONT, STYLE, SIZE, OR COLOR.

FOR SCENTED DEER ATTRACTANT (U.S. CLS. 22, 23, 38 AND 50).

FIRST USE 8-21-2009; IN COMMERCE 8-21-2009.
ERIN FALK, EXAMINING ATTORNEY

CLASS 28—(Continued).

SN 85-299,281. MATTEL, INC., EL SEGUNDO, CA. FILED 4-19-2011.

BARBIE CHAMPIONS

THE MARK CONSISTS OF STANDARD CHARACTERS WITHOUT CLAIM TO ANY PARTICULAR FONT, STYLE, SIZE, OR COLOR.

OWNER OF U.S. REG. NOS. 689,055, 741,208 AND OTHERS.

FOR DOLLS, DOLL CLOTHING AND DOLL ACCESSORIES (U.S. CLS. 22, 23, 38 AND 50).

JOHN GARTNER, EXAMINING ATTORNEY

SN 85-295,411. SJ ASSETS, LLC, EVANSTON, IL. FILED 4-14-2011.

EVERSQUEAK

THE MARK CONSISTS OF STANDARD CHARACTERS WITHOUT CLAIM TO ANY PARTICULAR FONT, STYLE, SIZE, OR COLOR.

FOR PET TOYS (U.S. CLS. 22, 23, 38 AND 50).
REBECCA SMITH, EXAMINING ATTORNEY

SN 85-299,283. MATTEL, INC., EL SEGUNDO, CA. FILED 4-19-2011.

SISTERS' PUP WALK

THE MARK CONSISTS OF STANDARD CHARACTERS WITHOUT CLAIM TO ANY PARTICULAR FONT, STYLE, SIZE, OR COLOR.

OWNER OF U.S. REG. NOS. 3,084,813, 3,253,350 AND 3,253,351.

NO CLAIM IS MADE TO THE EXCLUSIVE RIGHT TO USE "PUP", APART FROM THE MARK AS SHOWN.

FOR DOLLS, DOLL CLOTHING AND DOLL ACCESSORIES; TOY ANIMAL FIGURES AND ACCESSORIES THEREFOR (U.S. CLS. 22, 23, 38 AND 50).

JOHN GARTNER, EXAMINING ATTORNEY

SN 85-295,785. RAIDEN TECHNOLOGY INC, INDUSTRY, CA. FILED 4-14-2011.

MADHAWK 300

THE MARK CONSISTS OF STANDARD CHARACTERS WITHOUT CLAIM TO ANY PARTICULAR FONT, STYLE, SIZE, OR COLOR.

FOR REMOTE CONTROL TOYS, NAMELY, HELICOPTER (U.S. CLS. 22, 23, 38 AND 50).

FIRST USE 11-1-2009; IN COMMERCE 11-1-2009.
WILLIAM VERHOSEK, EXAMINING ATTORNEY

SN 85-300,376. MATTEL, INC., EL SEGUNDO, CA. FILED 4-20-2011.

SISTERS TRAIN TAFFY

THE MARK CONSISTS OF STANDARD CHARACTERS WITHOUT CLAIM TO ANY PARTICULAR FONT, STYLE, SIZE, OR COLOR.

OWNER OF U.S. REG. NOS. 3,084,790, 3,253,351 AND OTHERS.

FOR DOLLS, DOLL CLOTHING AND DOLL ACCESSORIES; TOY ANIMAL FIGURES AND ACCESSORIES THEREFOR (U.S. CLS. 22, 23, 38 AND 50).

JOHN GARTNER, EXAMINING ATTORNEY

CLASS 28—(Continued).

SN 85-308,761. CRAYOLA PROPERTIES, INC., EASTON, PA.
FILED 4-29-2011.

GLOW EXPLOSION

THE MARK CONSISTS OF STANDARD CHARACTERS
WITHOUT CLAIM TO ANY PARTICULAR FONT, STYLE,
SIZE, OR COLOR.

NO CLAIM IS MADE TO THE EXCLUSIVE RIGHT TO
USE "GLOW", APART FROM THE MARK AS SHOWN.
FOR BENDABLE TOYS (U.S. CLS. 22, 23, 38 AND 50).
FIRST USE 12-31-2010; IN COMMERCE 12-31-2010.
TOBY BULLOFF, EXAMINING ATTORNEY

CLASS 28—(Continued).

SN 85-311,972. MATTEL, INC., EL SEGUNDO, CA. FILED 5-
4-2011.

BOMB BLASTIN'

THE MARK CONSISTS OF STANDARD CHARACTERS
WITHOUT CLAIM TO ANY PARTICULAR FONT, STYLE,
SIZE, OR COLOR.

FOR TOY VEHICLES AND ACCESSORIES THEREFOR
(U.S. CLS. 22, 23, 38 AND 50).
JOHN GARTNER, EXAMINING ATTORNEY

SN 85-309,119. HOWARD S GOLD, SUDBURY, MA. FILED 4-
30-2011.

Galaxy Pals

THE MARK CONSISTS OF STANDARD CHARACTERS
WITHOUT CLAIM TO ANY PARTICULAR FONT, STYLE,
SIZE, OR COLOR.

FOR FANTASY CHARACTER TOYS (U.S. CLS. 22, 23,
38 AND 50).
MARK SPARACINO, EXAMINING ATTORNEY

SN 85-316,771. CALLAWAY GOLF COMPANY, CARLSBAD,
CA. FILED 5-10-2011.

UPUTT

THE MARK CONSISTS OF STANDARD CHARACTERS
WITHOUT CLAIM TO ANY PARTICULAR FONT, STYLE,
SIZE, OR COLOR.

FOR GOLF CLUBS (U.S. CLS. 22, 23, 38 AND 50).
BARBARA A. GOLD, EXAMINING ATTORNEY

SN 85-311,969. MATTEL, INC., EL SEGUNDO, CA. FILED 5-
4-2011.

BASH 'N' GO

THE MARK CONSISTS OF STANDARD CHARACTERS
WITHOUT CLAIM TO ANY PARTICULAR FONT, STYLE,
SIZE, OR COLOR.

FOR TOY VEHICLES AND ACCESSORIES THEREFOR
(U.S. CLS. 22, 23, 38 AND 50).
JOHN GARTNER, EXAMINING ATTORNEY

SN 85-316,912. CALLAWAY GOLF COMPANY, CARLSBAD,
CA. FILED 5-10-2011.

UDRIVE

THE MARK CONSISTS OF STANDARD CHARACTERS
WITHOUT CLAIM TO ANY PARTICULAR FONT, STYLE,
SIZE, OR COLOR.

FOR GOLF CLUBS (U.S. CLS. 22, 23, 38 AND 50).
BARBARA A. GOLD, EXAMINING ATTORNEY

CLASS 28—(Continued).

SN 85-318,750. GREENMASTER INDUSTRIAL CORP., TAI-CHUNG, TAIWAN, FILED 5-12-2011.

fit • do • be

THE MARK CONSISTS OF THREE WORDS "FIT", "DO" AND "BE" IN LOWER CASE FONT, AND TWO DOTS, ONE SITS IN THE MIDDLE BETWEEN WORDS "FIT" AND "DO", THE OTHER SITS IN THE MIDDLE BETWEEN WORDS "DO" AND "BE".

FOR AEROBIC STEP MACHINES; ELLIPTICAL EXERCISE MACHINES; EXERCISE EQUIPMENT NAMELY, ROWING MACHINES; EXERCISE EQUIPMENT, NAMELY, ABDOMINAL BOARDS; EXERCISE EQUIPMENT, NAMELY, CHEST PULLS; EXERCISING EQUIPMENT, NAMELY, POWERED TREADMILLS FOR RUNNING; EXERCISING EQUIPMENT, NAMELY, WEIGHT LIFTING MACHINES; FITNESS MACHINES AND EQUIPMENT, NAMELY, WEIGHTS, TREADMILLS, ROWING MACHINES, STAIR STEPPING MACHINES, RESISTANCE MACHINES, STATIONARY CYCLES; LEG WEIGHTS FOR EXERCISING; STATIONARY EXERCISE BICYCLES; STATIONARY EXERCISE BICYCLES AND ROLLERS THEREFOR; VIBRATING APPARATUS USED IN FITNESS AND EXERCISE PROGRAMS TO STIMULATE MUSCLES AND INCREASE STRENGTH AND PHYSICAL PERFORMANCE (U.S. CLS. 22, 23, 38 AND 50).

MICHAEL ENGEL, EXAMINING ATTORNEY

SN 85-322,804. WARRIOR SPORTS, INC., WARREN, MI. FILED 5-17-2011.



OWNER OF U.S. REG. NOS. 1,955,026, 3,580,473 AND OTHERS.

THE MARK CONSISTS OF A STYLIZED LETTER "W". FOR GOALKEEPERS' GLOVES; SHIN PADS FOR USE IN SOCCER; SOCCER BALL KNEE PADS; SOCCER BALLS; SOCCER GOALS (U.S. CLS. 22, 23, 38 AND 50). COLLEEN DOMBROW, EXAMINING ATTORNEY

CLASS 28—(Continued).

SN 85-325,177. PATCH PRODUCTS, INC., BELOIT, WI. FILED 5-19-2011.

Big Little Games

THE MARK CONSISTS OF STANDARD CHARACTERS WITHOUT CLAIM TO ANY PARTICULAR FONT, STYLE, SIZE, OR COLOR.

NO CLAIM IS MADE TO THE EXCLUSIVE RIGHT TO USE "GAMES", APART FROM THE MARK AS SHOWN.

FOR PARLOR GAMES (U.S. CLS. 22, 23, 38 AND 50). CHERYL CLAYTON, EXAMINING ATTORNEY

SN 85-332,756. CALLAWAY GOLF COMPANY, CARLSBAD, CA. FILED 5-27-2011.

RAZR XP_F

THE MARK CONSISTS OF THE TERM "RAZR" FOLLOWED BY THE UNITARY TERM, "XP_F", WITH THE "F" IN SUBSCRIPT, ALL IN SPECIAL FORM.

FOR GOLF BAGS; GOLF CLUBS; FITTED HEAD COVERS FOR GOLF CLUBS (U.S. CLS. 22, 23, 38 AND 50).

BARBARA A. GOLD, EXAMINING ATTORNEY

SN 85-332,787. CALLAWAY GOLF COMPANY, CARLSBAD, CA. FILED 5-27-2011.

RAZR XT_F

THE MARK CONSISTS OF THE TERM "RAZR" FOLLOWED BY THE UNITARY TERM, "XT_F", WITH THE "F" IN SUBSCRIPT, ALL IN SPECIAL FORM.

FOR GOLF BAGS; GOLF CLUBS; FITTED HEAD COVERS FOR GOLF CLUBS (U.S. CLS. 22, 23, 38 AND 50).

BARBARA A. GOLD, EXAMINING ATTORNEY

CLASS 29—MEATS AND PROCESSED FOODS

SN 76-702,819. AD ROSENBLATT KOSHER MEATS, LLC, DALLAS, TX. FILED 5-5-2010.

ROSENBLATT

THE MARK CONSISTS OF STANDARD CHARACTERS WITHOUT CLAIM TO ANY PARTICULAR FONT, STYLE, SIZE, OR COLOR.

THE NAME "ROSENBLATT" DOES NOT IDENTIFY A LIVING INDIVIDUAL.

SEC. 2(F).

FOR PREPARED MEAT; SAUSAGES (U.S. CL. 46).

FIRST USE 3-0-2004; IN COMMERCE 3-0-2004.

JAMES STEIN, EXAMINING ATTORNEY

CLASS 29—(Continued).

SN 77-931,450. MARTINEZ-GALLEGO, ANTONIO M., AKA ANTONIO MIGUEL MARTINEZ, SAN YSIDRO, CA. FILED 2-9-2010.



NO CLAIM IS MADE TO THE EXCLUSIVE RIGHT TO USE "BAJA GOLDEN DATES", APART FROM THE MARK AS SHOWN.

THE COLOR(S) GOLD IS/ARE CLAIMED AS A FEATURE OF THE MARK.

THE MARK CONSISTS OF THE FOLLOWING: THE WORDING "BAJA GOLDEN DATES" AND A DECORATIVE BORDER IN GOLD AND OUTLINE IN A DARKER SHADE OF GOLD.

THE ENGLISH TRANSLATION OF "BAJA" IN THE MARK IS "LOW".

FOR DRIED DATES (U.S. CL. 46).

MARIA-VICTORIA SUAREZ, EXAMINING ATTORNEY

SN 77-800,327. CORPORATIVE BRANDINGS AND INVESTMENTS, S.A. DE C.V., MEXICO, MEXICO D.F., MEXICO, FILED 8-8-2009.



OWNER OF MEXICO REG. NO. 1086114, DATED 2-19-2009, EXPIRES 2-4-2019.

THE COLOR(S) DARK BLUE, LIGHT BLUE AND GRAY IS/ARE CLAIMED AS A FEATURE OF THE MARK.

THE MARK CONSISTS OF THE WORD "BIOSURE" IN STYLIZED LETTERS. ALL LETTERS SHOW A SHADOW ON THE BACKGROUND. A DARKER COLOR BLUE APPEARS IN THE LETTERS "B" AND "S" AND A LIGHTER BLUE APPEARS ON THE LETTERS "IO" AND "SURE". THE COLOR GRAY APPEARS IN THE BACKGROUND.

THE WORDING "BIOSURE" HAS NO MEANING IN A FOREIGN LANGUAGE.

FOR COOKED FRUITS AND VEGETABLES; DAIRY PRODUCTS EXCLUDING ICE CREAM, ICE MILK AND FROZEN YOGURT; DRIED FRUIT AND VEGETABLES; EDIBLE OILS AND FATS; EGGS; FISH; FRUIT CONSERVES; JELLIES AND JAMS; MARMALADES; MEAT AND MEAT EXTRACTS; MILK; POULTRY AND GAME; PRESERVED FRUIT AND VEGETABLES (U.S. CL. 46).

LAURA KOVALSKY, EXAMINING ATTORNEY

SN 77-956,404. JLS FOODS INTERNATIONAL, INC., SCHAUMBURG, IL. FILED 3-11-2010.

SN 77-917,598. CROFTERS FOOD LTD., PARRY SOUND, ONTARIO, CANADA, FILED 1-22-2010.

PERFECTLY SWEETENED

THE MARK CONSISTS OF STANDARD CHARACTERS WITHOUT CLAIM TO ANY PARTICULAR FONT, STYLE, SIZE, OR COLOR.

OWNER OF CANADA REG. NO. TMA790995, DATED 2-17-2011, EXPIRES 2-17-2026.

NO CLAIM IS MADE TO THE EXCLUSIVE RIGHT TO USE "SWEETENED", APART FROM THE MARK AS SHOWN.

FOR FRUIT SPREADS, JAMS AND PRESERVES (U.S. CL. 46).

KAREN BRACEY, EXAMINING ATTORNEY

PROLAC

THE MARK CONSISTS OF STANDARD CHARACTERS WITHOUT CLAIM TO ANY PARTICULAR FONT, STYLE, SIZE, OR COLOR.

FOR FOOD ADDITIVES FOR THE PRODUCTION OF CHEESE, NAMELY, PROTEIN FOR USE AS A FOOD ADDITIVE IN CHEESE (U.S. CL. 46).

MAUREEN DALL, EXAMINING ATTORNEY

CLASS 29—(Continued).

SN 79-093,442. PESQUERA RODRIGUEZ, S.A., SAN SEBASTIAN (GUIPUZCOA), SPAIN, FILED 2-3-2011.



OWNER OF INTERNATIONAL REGISTRATION 1067227 DATED 2-3-2011, EXPIRES 2-3-2021.

NO CLAIM IS MADE TO THE EXCLUSIVE RIGHT TO USE "SA", APART FROM THE MARK AS SHOWN.

THE COLOR(S) RED AND BLUE IS/ARE CLAIMED AS A FEATURE OF THE MARK.

THE LETTERS "PR SA" ARE RED AS WELL AS THE EDGE, THE SHIELD, THE BAND WHICH CROSSES THIS IS BLUE.

FOR FISH AND PARTICULARLY CANNED FISH AND SEAFOOD (U.S. CL. 46).

ANGELA M. MICHELI, EXAMINING ATTORNEY

CLASS 29—(Continued).

SN 79-096,081. FUJIAN YADA GROUP CO.,LTD., CHINA, FILED 1-4-2011.



OWNER OF INTERNATIONAL REGISTRATION 1073728 DATED 1-4-2011, EXPIRES 1-4-2021.

THE COLOR(S) GREEN AND RED IS/ARE CLAIMED AS A FEATURE OF THE MARK.

THE MARK CONSISTS OF TWO CHINESE CHARACTERS LOCATED BELOW THE DEPICTION OF TWO SEMI-CIRCLES, THE LEFT ONE WHICH PARTIALLY SURROUNDS A CIRCLE. THE COLOR GREEN APPEARS IN THE TWO CHINESE CHARACTERS AS WELL AS THE TWO SEMI-CIRCLES. THE COLOR RED APPEARS IN THE CIRCLE THAT IS PARTIALLY SURROUNDED BY THE LEFT SEMI-CIRCLE AS WELL AS THE SMALL CIRCLE IN THE SECOND CHINESE CHARACTER.

THE NON-LATIN CHARACTERS IN THE MARK TRANSLITERATE TO "YADA" AND THIS HAS NO MEANING IN A FOREIGN LANGUAGE.

FOR POTATO CHIPS; YOLK OF EGGS; LOBSTERS, NOT LIVE; VEGETABLES, COOKED; VEGETABLES, DRIED; VEGETABLES, PRESERVED; MEAT JELLIES; GINGER JAM; JELLIES FOR FOOD; ONIONS, PRESERVED (U.S. CL. 46).

MICHAEL TANNER, EXAMINING ATTORNEY

SN 85-006,043. CALORIE COMFORT, LLC, ST. LOUIS, MO. FILED 4-5-2010.

CALORIE COMFORT

OWNER OF INTERNATIONAL REGISTRATION 1067227 DATED 2-3-2011, EXPIRES 2-3-2021.

NO CLAIM IS MADE TO THE EXCLUSIVE RIGHT TO USE "SA", APART FROM THE MARK AS SHOWN.

THE COLOR(S) RED AND BLUE IS/ARE CLAIMED AS A FEATURE OF THE MARK.

THE LETTERS "PR SA" ARE RED AS WELL AS THE EDGE, THE SHIELD, THE BAND WHICH CROSSES THIS IS BLUE.

FOR FISH AND PARTICULARLY CANNED FISH AND SEAFOOD (U.S. CL. 46).

ANGELA M. MICHELI, EXAMINING ATTORNEY

THE MARK CONSISTS OF STANDARD CHARACTERS WITHOUT CLAIM TO ANY PARTICULAR FONT, STYLE, SIZE, OR COLOR.

FOR FROZEN MEALS CONSISTING PRIMARILY OF MEAT, FISH, POULTRY OR VEGETABLES (U.S. CL. 46).

ANDREA HACK, EXAMINING ATTORNEY

CLASS 29—(Continued).

SN 85-006,482. ORGANIZACION ALTEX SA DE CV, MIGUEL HIDALGO, MEXICO, FILED 4-5-2010.

Citrex

THE MARK CONSISTS OF STANDARD CHARACTERS WITHOUT CLAIM TO ANY PARTICULAR FONT, STYLE, SIZE, OR COLOR.

PRIORITY CLAIMED UNDER SEC. 44(D) ON MEXICO APPLICATION NO. 1078544, FILED 3-30-2010, REG. NO. 1155381, DATED 3-27-2010, EXPIRES 3-27-2020.

OWNER OF U.S. REG. NO. 3,692,619.
FOR FROZEN FRUITS; FROZEN VEGETABLES (U.S. CL. 46).

BRIDGETT SMITH, EXAMINING ATTORNEY

SN 85-155,222. SPUD U CRAVE, LLC, LONGWOOD, FL. FILED 10-18-2010.

SPUD U CRAVE

THE MARK CONSISTS OF STANDARD CHARACTERS WITHOUT CLAIM TO ANY PARTICULAR FONT, STYLE, SIZE, OR COLOR.

NO CLAIM IS MADE TO THE EXCLUSIVE RIGHT TO USE "SPUD", APART FROM THE MARK AS SHOWN.

FOR POTATOES READY FOR CONSUMPTION, NAMELY, BAKED POTATOES AND SWEET POTATOES AND YAMS WITH VARIOUS FILLINGS AND/OR TOPPINGS; SALADS, NAMELY, VEGETABLE SALADS AND POTATO SALADS; PASTRIES, NAMELY, SWEET AND/OR SAVORY PASTRIES; AND BEVERAGES, NAMELY, MILK (U.S. CL. 46).

APRIL ROACH, EXAMINING ATTORNEY

SN 85-158,545. CREAM BEANS, INC., LAS VEGAS, NV. FILED 10-21-2010.

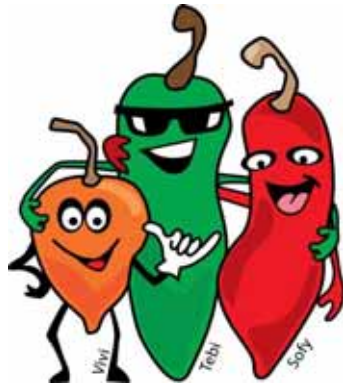

THE COLOR(S) ORANGE, DARK ORANGE, GREEN, RED, DARK RED, PINK, BROWN, TAN, BLACK, AND WHITE IS/ARE CLAIMED AS A FEATURE OF THE MARK.
THE MARK CONSISTS OF A DESIGN OF THREE

CLASS 29—(Continued).

PEPPERS, A HABANERO, JALAPENO AND CHIPOTLE, THE HABANERO PEPPER HAS THE WORDING "VIVI" IN BLACK BELOW IT WITH AN ORANGE AND DARK ORANGE BODY, TAN STEM, BLACK LEGS AND ARMS, RED TONGUE AND WHITE EYES AND HAND; THE JALAPENO PEPPER HAS THE WORDING "TEBI" IN BLACK BELOW IT WITH A GREEN BODY, BROWN STEM, BLACK SUNGLASSES WITH WHITE TEETH AND HIGHLIGHTS IN SUNGLASSES; THE CHIPOTLE PEPPER HAS THE WORDING "SOFY" IN BLACK BELOW IT WITH RED AND DARK RED BODY, TAN STEM, PINK TONGUE AND WHITE EYES.

FOR BEAN DIP (U.S. CL. 46).

DANIEL CAPSHAW, EXAMINING ATTORNEY

SN 85-164,656. ELDIB, MONA, DBA ELDIB ENGINEERING & RESEARCH, INC., LOS ANGELES, CA. FILED 10-29-2010.

Goat-Gurt

THE MARK CONSISTS OF STANDARD CHARACTERS WITHOUT CLAIM TO ANY PARTICULAR FONT, STYLE, SIZE, OR COLOR.

FOR YOGURTS MADE FROM GOAT'S MILK (U.S. CL. 46).

TARA PATE, EXAMINING ATTORNEY

SN 85-179,816. SOCIETE DES PRODUITS NESTLE S.A., 1800 VEVEY, SWITZERLAND, FILED 11-18-2010.

NINHO

THE MARK CONSISTS OF STANDARD CHARACTERS WITHOUT CLAIM TO ANY PARTICULAR FONT, STYLE, SIZE, OR COLOR.

THE ENGLISH TRANSLATION OF "NINHO" IN THE MARK IS "NEST".

FOR POWDERED MILK (U.S. CL. 46).

DAVID TOOLEY, EXAMINING ATTORNEY

CLASS 29—(Continued).

SN 85-204,769. ANDERSON INTERNATIONAL FOODS, INC., MINEOLA, NY. FILED 12-23-2010.

MONSEY DAIRY

THE MARK CONSISTS OF STANDARD CHARACTERS WITHOUT CLAIM TO ANY PARTICULAR FONT, STYLE, SIZE, OR COLOR.

NO CLAIM IS MADE TO THE EXCLUSIVE RIGHT TO USE "DAIRY", APART FROM THE MARK AS SHOWN.

FOR CHEESE (U.S. CL. 46).

FIRST USE 8-8-2001; IN COMMERCE 8-8-2001.

MARY BOAGNI, EXAMINING ATTORNEY

SN 85-226,475. HOME MARKET FOODS, INC., NORWOOD, MA. FILED 1-26-2011.

BOLDER BITES

THE MARK CONSISTS OF STANDARD CHARACTERS WITHOUT CLAIM TO ANY PARTICULAR FONT, STYLE, SIZE, OR COLOR.

NO CLAIM IS MADE TO THE EXCLUSIVE RIGHT TO USE "BITES", APART FROM THE MARK AS SHOWN.

FOR MEAT BASED SNACK FOODS (U.S. CL. 46).

CHRISTINE COOPER, EXAMINING ATTORNEY

SN 85-227,204. GREEN VISIONS, INC., DYERSVILLE, IA. FILED 1-26-2011.



NO CLAIM IS MADE TO THE EXCLUSIVE RIGHT TO USE "ORGANIC", APART FROM THE MARK AS SHOWN.

THE MARK CONSISTS OF A SHIELD, AS IN A COAT OF ARMS, WITH A BOAR'S HEAD IN THE UPPER RIGHT CORNER, AND AN ACORN IN THE LOWER LEFT CORNER, IN THE MIDDLE, RUNNING FROM UPPER LEFT TO LOWER RIGHT, A WAVY BEND. BELOW THE COAT OF ARMS IS A SCROLL CONTAINING THE WORDS "BECKER

CLASS 29—(Continued).

LANE ORGANIC". THE MARK IS ALSO RENDERED WITH MANTLING ABOVE THE SHIELD AND A ROPE SHAPED BORDER, WITH A STYLIZED BACKGROUND. THE DESCRIPTION HERALDICALLY IS: A SHIELD, GULES, A BEND WAVY, IN CHIEF A BOAR'S HEAD COUPED (SCOTTISH), IN BASE AN ACORN REVERSED, ARGENT. MANTLING GULES AND ARGENT. BELOW, A SCROLL WITH "BECKER LANE", SABLE, "ORGANIC", GULES. ALL WITHIN A ROPE CIRCLE, ARGENT, UPON A STYLIZED BACKGROUND.

FOR ORGANICALLY RAISED PORK; ORGANIC PORK PRODUCTS, NAMELY, SAUSAGES, CURED PORK, FRESH PORK, FROZEN PORK, PRIMAL AND SUB-PRIMAL CUTS OF PORK, WHOLE CARCASSES OF PORK, AND BOXED PORK FOR HUMAN CONSUMPTION (U.S. CL. 46).

FIRST USE 7-28-2007; IN COMMERCE 12-2-2008.

CURTIS FRENCH, EXAMINING ATTORNEY

SN 85-258,574. DERYAN INC., DBA HEALTHY SENSATIONS, LOS ANGELES, CA. FILED 3-4-2011.



NO CLAIM IS MADE TO THE EXCLUSIVE RIGHT TO USE "HEALTHY", APART FROM THE MARK AS SHOWN. THE COLOR(S) WHITE, GREEN, AND RED IS/ARE CLAIMED AS A FEATURE OF THE MARK.

THE MARK CONSISTS OF THE FOLLOWING: THE GREEN WORD "HEALTHY" IN STYLIZED FONT WITH TWO GREEN AND WHITE LEAVES PROTRUDING FROM THE TOP OF THE LETTER "L", AND THE RED WORD "SENSATIONS" BELOW.

FOR DAIRY PRODUCTS EXCLUDING ICE CREAM, ICE MILK AND FROZEN YOGURT; MEAT, FISH, POULTRY AND GAME; MEAT, POULTRY AND GAME; FROZEN MEALS CONSISTING PRIMARILY OF MEAT, FISH, POULTRY OR VEGETABLES; FROZEN VEGETABLE-BASED ENTREES (U.S. CL. 46).

JOHN KELLY, EXAMINING ATTORNEY

SN 85-264,251. GREENISLAND SEAFOOD PRODUCTS LTD., TORONTO, ON, CANADA, FILED 3-11-2011.

GREEN OCEAN

THE MARK CONSISTS OF STANDARD CHARACTERS WITHOUT CLAIM TO ANY PARTICULAR FONT, STYLE, SIZE, OR COLOR.

OWNER OF CANADA REG. NO. 773250, DATED 7-29-2010, EXPIRES 7-29-2025.

FOR FRESH AND FROZEN RAW FISH, SEAFOOD AND CRUSTACEA; FRESH AND FROZEN PREPARED FISH, SEAFOOD AND CRUSTACEA; COOKED FISH, SEAFOOD AND CRUSTACEA; PREPARED FROZEN ENTREES COMPRISED MAINLY OF FISH, SEAFOOD OR CRUSTACEA; BREADED, BATTERED AND MARINATED FISH, SEAFOOD AND CRUSTACEA (U.S. CL. 46).

KELLEY WELLS, EXAMINING ATTORNEY

CLASS 29—(Continued).

SN 85-264,410. NELVANA INTERNATIONAL LIMITED, LIMERICK, IRELAND, FILED 3-11-2011.



THE MARK CONSISTS OF THE WORDING "BADOU" IN A STYLIZED FONT. THE COLORS "BLACK", "WHITE" AND "GRAY" REPRESENT OUTLINING AND SHADING AND ARE NOT PART OF THE MARK.

THE WORDING "BADOU" HAS NO MEANING IN A FOREIGN LANGUAGE.

FOR MEAT, FISH, POULTRY AND GAME; MEAT EXTRACTS; PRESERVED, DRIED AND COOKED FRUITS AND VEGETABLES; JELLIES, JAMS, COMPOTES; EGGS, MILK AND MILK PRODUCTS EXCLUDING ICE CREAM, ICE MILK AND FROZEN YOGURT; EDIBLE OILS AND FATS (U.S. CL. 46).

RENEE MCCRAY, EXAMINING ATTORNEY

CLASS 29—(Continued).

SN 85-268,845. MUNIZ JULIO, MIAMI, FL. FILED 3-16-2011.



NO CLAIM IS MADE TO THE EXCLUSIVE RIGHT TO USE "AGROINDUSTRIA", APART FROM THE MARK AS SHOWN.

THE COLOR(S) WHITE, GREEN, AND YELLOW IS/ARE CLAIMED AS A FEATURE OF THE MARK.

THE MARK CONSISTS OF THE GREEN WORDING "AGROINDUSTRIA", THE YELLOW WORDING "XOMOR", WITH GREEN OUTLINING AROUND THE LETTER "X" AND GREEN SHADOWING BEHIND THE OTHER LETTERS. THE MARK ALSO INCLUDES CURVED OVERLAPPING YELLOW AND GREEN LINES, A GREEN AND WHITE TRACTOR, AND A GREEN AND WHITE RACCOON. THE MARK APPEARS ON A WHITE BACKGROUND.

THE ENGLISH TRANSLATION OF "AGROINDUSTRIA" IN THE MARK IS "AGRO INDUSTRY". THE WORDING "XOMOR" HAS NO MEANING IN A FOREIGN LANGUAGE.

FOR CANDIED NUTS; FIG AND DATE ROLL CONSISTING OF DRIED FRUITS, NUTS, AND SPICES; FLAVORED NUTS; FRUIT-BASED ORGANIC FOOD BARS, ALSO CONTAINING NUTS; NUT AND SEED-BASED SNACK BARS; NUT BUTTERS; PROCESSED NUTS, NAMELY, NUT CREAM; NUT CHEESE, NAMELY, CHEESE-TYPE PRODUCT MADE FROM NUTS; NUT FLOURS; NUT MEATS; NUT TOPPING; NUT-BASED MILK; NUT-BASED SNACK FOODS; NUT-BASED SNACK FOODS, NAMELY, NUT CLUSTERS; NUT-BASED SNACK FOODS, NAMELY, NUT CRISPS; ORGANIC NUT AND SEED-BASED SNACK BARS; PREPARED NUTS; PROCESSED FRUIT- AND NUT-BASED FOOD BARS; PROCESSED NUTS; PROCESSED PIGNOLI PINE NUTS; ROASTED NUTS; SEASONED NUTS; SHELLED NUTS; SNACK MIX CONSISTING OF DEHYDRATED FRUIT AND PROCESSED NUTS; SNACK MIX CONSISTING OF PRIMARILY OF PROCESSED NUTS, SEEDS, DRIED FRUIT AND ALSO INCLUDING CHOCOLATE; SNACK MIX CONSISTING OF WASABI PEAS, PROCESSED NUTS, DEHYDRATED FRUIT AND/OR RAISINS; SNACK MIX CONSISTING PRIMARILY OF DEHYDRATED FRUITS, PROCESSED NUTS AND ALSO INCLUDING SESAME STICKS; SNACK MIX CONSISTING PRIMARILY OF PROCESSED FRUITS, PROCESSED NUTS AND/OR RAISINS; SNACK MIX CONSISTING PRIMARILY OF PROCESSED NUTS AND SALTED SQUASH SEEDS AND ALSO INCLUDING TOASTED CORN; SOY-BASED FOOD BARS ALSO CONTAINING NUTS; TRAIL MIX CONSISTING PRIMARILY OF PROCESSED NUTS, SEEDS, DRIED FRUIT AND ALSO INCLUDING CHOCOLATE (U.S. CL. 46).

KIM MONINGHOFF, EXAMINING ATTORNEY

SN 85-268,705. MUNIZ JULIO, MIAMI, FL. FILED 3-16-2011.



THE MARK CONSISTS OF A STYLISH IMAGE OF A JAPANESE TEMPLE WITH THE WORD "KIOTO" ON TOP ALL IN A CIRCLE.

THE ENGLISH TRANSLATION OF "KIOTO" IN THE MARK IS "KYOTO".

FOR CANNED PEANUTS; PEANUT BUTTER; PEANUT BUTTER TOPPINGS; PEANUT PASTE; PEANUT SPREAD; PEANUT-BASED FOOD BEVERAGES; PROCESSED PEANUTS (U.S. CL. 46).

KIM MONINGHOFF, EXAMINING ATTORNEY

CLASS 29—(Continued).

SN 85-269,658. WESTERN MIXERS PRODUCE & NUTS, INC., FORMERLY WESTERN MIXERS, INC., LOS ANGELES, CA. FILED 3-17-2011.



THE MARK CONSISTS OF A RECTANGLE DIVIDED TWICE INTO THREE SECTIONS, WITH THE TOP AND BOTTOM SECTIONS WITH A DECORATIVE BORDER. BACKGROUND OF CENTER RECTANGLE AREA RESEMBLES BUILDING STUCCO TEXTURE AND A SEMI-CIRCLE SHAPED ARCH IS BORDERED WITH BRICKS. ROSES ADORN THE SEMI-CIRCLE ON BOTH SIDES. THE WORDING "TESORO DE LA COSECHA" APPEARS IN THE MIDDLE WITH "TREASURED HARVEST" BELOW THE WORDING. SPECIFIC COLORS ARE NOT CLAIMED AS A FEATURE OF THE MARK.

THE ENGLISH TRANSLATION OF "TESORO DE LA COSECHA" IN THE MARK IS "TREASURED HARVEST". FOR PROCESSED NUTS (U.S. CL. 46). FIRST USE 1-1-1998; IN COMMERCE 1-1-1998. ALICE BENMAMAN, EXAMINING ATTORNEY

SN 85-270,283. GRANDMA LU'S SPICE CABINET, LLC, AUSTIN, TX. FILED 3-18-2011.

World Peas
BRINGING PEAS TO THE WORLD

THE MARK CONSISTS OF THE TERM "WORLD PEAS" AND CENTERED BELOW IS "BRINGING PEAS TO THE WORLD".

FOR PEAS, NAMELY, PREPARED, FRIED AND SPICED PEAS (U.S. CL. 46).

Laurie Mayes, Examining Attorney

CLASS 29—(Continued).

SN 85-272,239. JERKIN' IT LLC, PANAMA CITY, FL. FILED 3-21-2011.

JERKIN' IT

THE MARK CONSISTS OF STANDARD CHARACTERS WITHOUT CLAIM TO ANY PARTICULAR FONT, STYLE, SIZE, OR COLOR.

NO CLAIM IS MADE TO THE EXCLUSIVE RIGHT TO USE "JERKING", APART FROM THE MARK AS SHOWN. FOR JERKY (U.S. CL. 46).

FIRST USE 4-20-2010; IN COMMERCE 4-20-2010. MEGHAN REINHART, EXAMINING ATTORNEY

SN 85-273,615. J.T. FARMS, LLC, MANCHESTER, CT. FILED 3-22-2011.

Leanmaster

THE MARK CONSISTS OF STANDARD CHARACTERS WITHOUT CLAIM TO ANY PARTICULAR FONT, STYLE, SIZE, OR COLOR.

FOR MEAT (U.S. CL. 46).

NELSON SNYDER, EXAMINING ATTORNEY

SN 85-274,177. NAKED JUICE CO. OF GLENDORA, INC., MONROVIA, CA. FILED 3-23-2011.



OWNER OF U.S. REG. NOS. 1,486,401, 3,316,179 AND OTHERS.

THE MARK CONSISTS OF THE WORD "NAKED" AND A LEAF DESIGN BETWEEN THE LETTERS K AND E OF THE WORD. THE MARK IS SET WITHIN A BANNER TYPE BACKGROUND.

FOR VEGETABLE-BASED SOUP AND VEGETABLE-BASED CHILI (U.S. CL. 46).

ROBIN CHOSID, EXAMINING ATTORNEY

CLASS 29—(Continued).

SN 85-274,916. CARL BUDDIG AND COMPANY, HOMEWOOD, IL. FILED 3-23-2011.

BUDDIG ORIGINAL

THE MARK CONSISTS OF STANDARD CHARACTERS WITHOUT CLAIM TO ANY PARTICULAR FONT, STYLE, SIZE, OR COLOR.

OWNER OF U.S. REG. NOS. 1,166,688, 2,998,828 AND OTHERS.

NO CLAIM IS MADE TO THE EXCLUSIVE RIGHT TO USE "ORIGINAL", APART FROM THE MARK AS SHOWN. FOR BEEF, HAM, TURKEY AND CHICKEN (U.S. CL. 46).

FIRST USE 5-1-2010; IN COMMERCE 5-1-2010.
JILL C. ALT, EXAMINING ATTORNEY

SN 85-274,968. CARL BUDDIG AND COMPANY, HOMEWOOD, IL. FILED 3-23-2011.



OWNER OF U.S. REG. NOS. 1,166,688, 2,940,596 AND 2,998,828.

NO CLAIM IS MADE TO THE EXCLUSIVE RIGHT TO USE "ORIGINAL", APART FROM THE MARK AS SHOWN.

THE MARK CONSISTS OF TWO CONCENTRIC OVALS IN THE CENTER OF WHICH LIES THE WORD "BUDDIG" IN HIGHLY STYLIZED, THICK, UPPER-AND-LOWER CASE CURSIVE SCRIPT WITH DOUBLE OUTLINING AND SHADOW, AND UNDERNEATH IT, THE WORD "ORIGINAL" IN SMALLER, LESS STYLIZED CAPITAL LETTERS.

FOR BEEF, HAM, TURKEY AND CHICKEN (U.S. CL. 46).

FIRST USE 5-1-2010; IN COMMERCE 5-1-2010.
JILL C. ALT, EXAMINING ATTORNEY

SN 85-276,166. LAWRENCE, JACKSON, ROCKY MOUNT, NC. FILED 3-24-2011.

WINGNUTS

THE MARK CONSISTS OF STANDARD CHARACTERS WITHOUT CLAIM TO ANY PARTICULAR FONT, STYLE, SIZE, OR COLOR.

OWNER OF U.S. REG. NO. 2,866,821.
FOR ROASTED NUTS; SEASONED NUTS; SHELLED NUTS (U.S. CL. 46).

FIRST USE 6-13-2003; IN COMMERCE 7-1-2003.
JUDITH HELFMAN, EXAMINING ATTORNEY

CLASS 29—(Continued).

SN 85-276,209. TREE TOP, INC., SELAH, WA. FILED 3-24-2011.

FRUIT DIMENSIONS

THE MARK CONSISTS OF STANDARD CHARACTERS WITHOUT CLAIM TO ANY PARTICULAR FONT, STYLE, SIZE, OR COLOR.

OWNER OF U.S. REG. NOS. 2,931,728, 3,701,928 AND OTHERS.

NO CLAIM IS MADE TO THE EXCLUSIVE RIGHT TO USE "FRUIT", APART FROM THE MARK AS SHOWN. FOR FRUIT-BASED SNACK FOOD (U.S. CL. 46).
MAYUR VAGHANI, EXAMINING ATTORNEY

SN 85-289,647. THE BOMB STEAK, LOS ANGELES, CA. FILED 4-7-2011.

THE BOMB STEAK

THE MARK CONSISTS OF STANDARD CHARACTERS WITHOUT CLAIM TO ANY PARTICULAR FONT, STYLE, SIZE, OR COLOR.

NO CLAIM IS MADE TO THE EXCLUSIVE RIGHT TO USE "STEAK", APART FROM THE MARK AS SHOWN.

FOR BEEF; MARINATED MEAT; SEASONED MEAT (U.S. CL. 46).

JOHN WILKE, EXAMINING ATTORNEY

SN 85-289,887. SKI'S ENTERPRISES LLC, POUND, WI. FILED 4-8-2011.

MEATSKI'S

THE MARK CONSISTS OF STANDARD CHARACTERS WITHOUT CLAIM TO ANY PARTICULAR FONT, STYLE, SIZE, OR COLOR.

FOR BEEF; HAMBURGER; HOT DOGS; MEAT; PORK; SAUSAGES (U.S. CL. 46).

GENE MACIOL, EXAMINING ATTORNEY

CLASS 29—(Continued).

SN 85-291,641. PRODUCTOS NATURALES DE LA SABANA S.A. ALQUERIA, CAJICA, COLOMBIA, FILED 4-11-2011.



OWNER OF U.S. REG. NO. 3,308,097.
THE COLOR(S) RED AND WHITE IS/ARE CLAIMED AS A FEATURE OF THE MARK.
THE MARK CONSISTS OF A RED COW'S HEAD DRAWING, FORMED BY A WHITE SPLASH OVER A RED BACKGROUND.

FOR CREAM; DAIRY PRODUCTS EXCLUDING ICE CREAM, ICE MILK AND FROZEN YOGURT; MILK; MILK BEVERAGES CONTAINING FRUITS; MILK BEVERAGES WITH HIGH MILK CONTENT; MILK PRODUCTS EXCLUDING ICE CREAM, ICE MILK AND FROZEN YOGURT (U.S. CL. 46).

ANDREW LEASER, EXAMINING ATTORNEY

SN 85-292,074. MICAL SEAFOOD INC, MARGATE, FL. FILED 4-11-2011.

HONDUFARMS BRAND

THE MARK CONSISTS OF STANDARD CHARACTERS WITHOUT CLAIM TO ANY PARTICULAR FONT, STYLE, SIZE, OR COLOR.

NO CLAIM IS MADE TO THE EXCLUSIVE RIGHT TO USE "BRAND", APART FROM THE MARK AS SHOWN.

FOR SHRIMPS, NOT LIVE (U.S. CL. 46).
BRIAN PINO, EXAMINING ATTORNEY

SN 85-292,237. JOHN FERRENTINO, FAIR LAWN, NJ. FILED 4-11-2011.

COWBOY BEEF

THE MARK CONSISTS OF STANDARD CHARACTERS WITHOUT CLAIM TO ANY PARTICULAR FONT, STYLE, SIZE, OR COLOR.

NO CLAIM IS MADE TO THE EXCLUSIVE RIGHT TO USE "BEEF", APART FROM THE MARK AS SHOWN.

FOR CHILI (U.S. CL. 46).
MICHAEL WEBSTER, EXAMINING ATTORNEY

CLASS 29—(Continued).

SN 85-292,240. JOHN FERRENTINO, FAIR LAWN, NJ. FILED 4-11-2011.

BANZO MASALA

THE MARK CONSISTS OF STANDARD CHARACTERS WITHOUT CLAIM TO ANY PARTICULAR FONT, STYLE, SIZE, OR COLOR.

NO CLAIM IS MADE TO THE EXCLUSIVE RIGHT TO USE "MASALA", APART FROM THE MARK AS SHOWN.

THE ENGLISH TRANSLATION OF THE WORD "MASALA" IN THE MARK IS "SPICE".

FOR CHILI (U.S. CL. 46).
MICHAEL WEBSTER, EXAMINING ATTORNEY

SN 85-292,245. JOHN FERRENTINO, FAIR LAWN, NJ. FILED 4-11-2011.

BaBOOM! BEEF

THE MARK CONSISTS OF STANDARD CHARACTERS WITHOUT CLAIM TO ANY PARTICULAR FONT, STYLE, SIZE, OR COLOR.

NO CLAIM IS MADE TO THE EXCLUSIVE RIGHT TO USE "BEEF", APART FROM THE MARK AS SHOWN.

FOR CHILI (U.S. CL. 46).
MICHAEL WEBSTER, EXAMINING ATTORNEY

SN 85-292,247. JOHN FERRENTINO, FAIR LAWN, NJ. FILED 4-11-2011.

ALL-STAR TURKEY

THE MARK CONSISTS OF STANDARD CHARACTERS WITHOUT CLAIM TO ANY PARTICULAR FONT, STYLE, SIZE, OR COLOR.

NO CLAIM IS MADE TO THE EXCLUSIVE RIGHT TO USE "TURKEY", APART FROM THE MARK AS SHOWN.

FOR CHILI (U.S. CL. 46).
MICHAEL WEBSTER, EXAMINING ATTORNEY

CLASS 29—(Continued).

SN 85-293,241. THE HAPPY PIG LLC, DALLAS, TX. FILED 4-12-2011.

Faconator

THE MARK CONSISTS OF STANDARD CHARACTERS WITHOUT CLAIM TO ANY PARTICULAR FONT, STYLE, SIZE, OR COLOR.

FOR MEAT SUBSTITUTES, NAMELY, VEGETARIAN MEATLOAF (U.S. CL. 46).
DAVID COLLIER, EXAMINING ATTORNEY

SN 85-294,032. CYPRESS GROVE CHEVRE, INC., ARCATA, CA. FILED 4-13-2011.

PURPLE HAZE

THE MARK CONSISTS OF STANDARD CHARACTERS WITHOUT CLAIM TO ANY PARTICULAR FONT, STYLE, SIZE, OR COLOR.

FOR CHEESE (U.S. CL. 46).
FIRST USE 8-2-2002; IN COMMERCE 8-2-2002.
GIANCARLO CASTRO, EXAMINING ATTORNEY

SN 85-294,127. PT. CENTRAL PERTIWI BAHARI, JAKARTA, INDONESIA, FILED 4-13-2011.

Bird River

THE MARK CONSISTS OF STANDARD CHARACTERS WITHOUT CLAIM TO ANY PARTICULAR FONT, STYLE, SIZE, OR COLOR.

OWNER OF U.S. REG. NO. 3,205,901.
FOR TILAPIA FISH, NAMELY SKINLESS TILAPIA FISH, SKIN-ON TILAPIA FILLET, MEAT BLOCK TILAPIA, WHOLE ROUND TILAPIA, WHOLE GUTTED AND SCALED TILPIA, WHOLE GILLED, GUTTED AND SCALED TILAPIA (U.S. CL. 46).
NAAKWAMA ANKRAH, EXAMINING ATTORNEY

CLASS 29—(Continued).

SN 85-311,321. KRAFT FOODS GLOBAL BRANDS LLC, NORTHFIELD, IL. FILED 5-3-2011.

MAKE SOMETHING AMAZING

THE MARK CONSISTS OF STANDARD CHARACTERS WITHOUT CLAIM TO ANY PARTICULAR FONT, STYLE, SIZE, OR COLOR.

FOR CHEESE (U.S. CL. 46).
SETH A. RAPPAPORT, EXAMINING ATTORNEY

SN 85-312,138. THE KROGER CO. OF MICHIGAN, NOVI, MI. FILED 5-4-2011.

SIMPLE TRUTH NATURAL

THE MARK CONSISTS OF STANDARD CHARACTERS WITHOUT CLAIM TO ANY PARTICULAR FONT, STYLE, SIZE, OR COLOR.

NO CLAIM IS MADE TO THE EXCLUSIVE RIGHT TO USE "NATURAL", APART FROM THE MARK AS SHOWN. FOR NATURAL EGGS; NATURAL MILK (U.S. CL. 46).
BARBARA BROWN, EXAMINING ATTORNEY

SN 85-312,167. THE KROGER CO. OF MICHIGAN, NOVI, MI. FILED 5-4-2011.

SIMPLE TRUTH ORGANIC

THE MARK CONSISTS OF STANDARD CHARACTERS WITHOUT CLAIM TO ANY PARTICULAR FONT, STYLE, SIZE, OR COLOR.

NO CLAIM IS MADE TO THE EXCLUSIVE RIGHT TO USE "ORGANIC", APART FROM THE MARK AS SHOWN. FOR ORGANIC EGGS; ORGANIC MILK (U.S. CL. 46).
BARBARA BROWN, EXAMINING ATTORNEY

SN 85-344,649. BARILLA G. E R. FRATELLI - SOCIETÀ PER AZIONI, PARMA, ITALY, FILED 6-13-2011.

SPAGHETTATA

THE MARK CONSISTS OF STANDARD CHARACTERS WITHOUT CLAIM TO ANY PARTICULAR FONT, STYLE, SIZE, OR COLOR.

FOR OLIVE OIL, CHEESE, PREPARED AND/OR PACKAGED FOODS, DISHES, AND MEALS, CONSISTING PRIMARILY OF MEATS, POULTRY, VEGETABLES AND/OR FRUITS (U.S. CL. 46).
AISHA CLARKE, EXAMINING ATTORNEY

CLASS 29—(Continued).

SN 85-356,919. SF INVESTMENTS, INC., WILMINGTON, DE.
FILED 6-27-2011.

SUMMER SPIRAL

THE MARK CONSISTS OF STANDARD CHARACTERS
WITHOUT CLAIM TO ANY PARTICULAR FONT, STYLE,
SIZE, OR COLOR.

NO CLAIM IS MADE TO THE EXCLUSIVE RIGHT TO
USE "SPIRAL", APART FROM THE MARK AS SHOWN.

FOR HAM (U.S. CL. 46).
JUDITH HELFMAN, EXAMINING ATTORNEY

CLASS 30—(Continued).

SN 77-522,518. CANTERBURY COFFEE CORPORATION,
RICHMOND, CANADA, FILED 7-15-2008.

resIPROcate

PRIORITY CLAIMED UNDER SEC. 44(D) ON CANADA
APPLICATION NO. 1,394,966, FILED 5-9-2008, REG. NO.
TMA797,007, DATED 5-9-2011, EXPIRES 5-9-2026.

THE MARK CONSISTS OF THE TERM "RESIPROCATE"
IN STYLIZED FORM.

FOR COFFEE (U.S. CL. 46).
HEATHER BIDDULPH, EXAMINING ATTORNEY

SN 78-470,877. BEN & JERRY'S HOMEMADE, INC., BUR-
LINGTON, VT. FILED 8-20-2004.

CHOCOLATE THERAPY**CLASS 30—STAPLE FOODS**

SN 76-706,008. BE MY GUEST, LTD., EDGARTOWN, MA.
FILED 1-14-2011.

BE MY GUEST

THE MARK CONSISTS OF STANDARD CHARACTERS
WITHOUT CLAIM TO ANY PARTICULAR FONT, STYLE,
SIZE, OR COLOR.

NO CLAIM IS MADE TO THE EXCLUSIVE RIGHT TO
USE "CHOCOLATE", APART FROM THE MARK AS
SHOWN.

FOR ICE CREAM AND FROZEN CONFECTIONS (U.S.
CL. 46).
JENNIFER DIXON, EXAMINING ATTORNEY

SN 78-901,028. EDWARD B. BEHARRY & CO., LTD.,
GEORGETOWN, GUYANA, FILED 6-5-2006.

THE MARK CONSISTS OF STANDARD CHARACTERS
WITHOUT CLAIM TO ANY PARTICULAR FONT, STYLE,
SIZE, OR COLOR.

FOR GRANOLA (U.S. CL. 46).
FIRST USE 7-28-2009; IN COMMERCE 7-28-2009.
JEFFREY LOOK, EXAMINING ATTORNEY

SN 76-707,241. JJI HEALTH PRODUCTS, LLC, BEAUMONT,
TX. FILED 4-13-2011.

EASY BAR

THE MARK CONSISTS OF STANDARD CHARACTERS
WITHOUT CLAIM TO ANY PARTICULAR FONT, STYLE,
SIZE, OR COLOR.

NO CLAIM IS MADE TO THE EXCLUSIVE RIGHT TO
USE "BAR", APART FROM THE MARK AS SHOWN.

FOR CANDY CONTAINING CALMING AGENTS FOR
PROMOTING RELAXATION (U.S. CL. 46).

MICHAEL WIENER, EXAMINING ATTORNEY



NO CLAIM IS MADE TO THE EXCLUSIVE RIGHT TO
USE "ICING SUGAR", APART FROM THE MARK AS
SHOWN.

THE COLOR(S) YELLOW, RED, PINK, PURPLE, BLUE,
GREEN, BROWN, BLACK AND WHITE IS/ARE CLAIMED
AS A FEATURE OF THE MARK.

THE COLOR YELLOW APPEARS IN THE LINES ABOVE
AND BELOW THE WORD "CHAMPION", IN THE BOX
SURROUNDING THE WORD "CHAMPION", OUTLINING
THE WORDS "ICING SUGAR", IN THE FIRST CURVY
LINE IN THE BOTTOM PORTION OF THE MARK AND IN
THE BACKGROUND AT THE BOTTOM OF THE MARK;

CLASS 30—(Continued).

THE COLOR RED APPEARS IN THE LINES ABOVE AND BELOW AND TO THE LEFT AND RIGHT OF THE WORD "CHAMPION", IN THE WORDS "ICING SUGAR", AND IN THE FIFTH CURVY LINE IN THE BOTTOM PORTION OF THE MARK; THE COLOR PINK APPEARS IN THE CONFECTION DESIGN IN THE BACKGROUND OF THE MARK AND IN THE SECOND CURVY LINE IN THE BOTTOM PORTION OF THE MARK; THE COLOR PURPLE APPEARS IN THE FOURTH CURVY LINE IN THE BOTTOM PORTION OF THE MARK; THE COLOR BLUE APPEARS IN THE THIRD CURVY LINE IN THE BOTTOM PORTION OF THE MARK; THE COLOR GREEN APPEARS IN THE SIXTH CURVY LINE IN THE BOTTOM PORTION OF THE MARK; THE COLOR BROWN APPEARS IN THE CONFECTION DESIGN IN THE BACKGROUND OF THE MARK; THE COLOR BLACK APPEARS IN THE WORD "CHAMPION" AND IN THE DESIGNS OUTLINING THE WORD "CHAMPION"; THE COLOR WHITE APPEARS IN THE UPPER PORTION OF THE BACKGROUND OF THE MARK.

FOR SUGAR; ICING SUGAR; FROSTING FOR CAKES AND PASTRIES (U.S. CL. 46).

SALLY SHIH, EXAMINING ATTORNEY

CLASS 30—(Continued).

SN 85-044,055. SPICY WORLD OF USA, INC, HOUSTON, TX. FILED 5-20-2010.



NO CLAIM IS MADE TO THE EXCLUSIVE RIGHT TO USE "SPICY", APART FROM THE MARK AS SHOWN.

THE COLOR(S) RED, WHITE, GOLD AND BROWN IS/ARE CLAIMED AS A FEATURE OF THE MARK.

THE MARK CONSISTS OF OVAL SHAPED LOGO CONSISTING OF THE WORDS "SPICY WORLD". BACKGROUND COLOR OF LOGO IS RED, WORDS "SPICY WORLD" ARE IN WHITE, AND SURROUNDING BORDER IS BROWN AND GOLD.

FOR EDIBLE FLOUR; EDIBLE SPICES; ENRICHED RICE (U.S. CL. 46).

FIRST USE 12-9-2003; IN COMMERCE 12-9-2003.

HENRY S. ZAK, EXAMINING ATTORNEY

SN 79-087,767. VIRMINA TRADING LIMITED, CYPRUS, FILED 9-27-2010.

EGOISTE

THE MARK CONSISTS OF STANDARD CHARACTERS WITHOUT CLAIM TO ANY PARTICULAR FONT, STYLE, SIZE, OR COLOR.

OWNER OF INTERNATIONAL REGISTRATION 0923263 DATED 4-9-2007, EXPIRES 4-9-2017.

THE ENGLISH TRANSLATION OF "EGOISTE" IN THE MARK IS "EGOISTIC" OR "SELFISH".

FOR COFFEE; TEA; ARTIFICIAL COFFEE; COCOA; SUGAR; RICE; TAPIOCA; SAGO; FLOUR; PREPARATIONS MADE FROM CEREALS, NAMELY, MUESLI, PASTA, BREAKFAST CEREALS, CEREAL BASED SNACK FOODS, READY TO EAT CEREAL DERIVED FOOD BARS; BREAD; PASTRY; CONFECTIONERY, NAMELY, SWEETS, CANDIES, MARZIPAN, COOKIES, CAKES, HALVA, FROZEN CONFECTIONERY, CHOCOLATE; ICES; HONEY; TREACLE; YEAST; BAKING-POWDER; SALT; MUSTARD; VINEGAR; CONDIMENTS, NAMELY, SAUCES, SEASONINGS FOR SOUPS, PASTRIES, MEAT DISHES, FISH AND POULTRY; SPICES; (U.S. CL. 46).

TINA BROWN, EXAMINING ATTORNEY

SN 85-078,929. 2R-HEALTH, INC., VERO BEACH, FL. FILED 7-6-2010.



OWNER OF U.S. REG. NO. 3,784,254.

THE MARK CONSISTS OF "2RHEALTH" DISPOSED BELOW AN ARCH CURVING DOWNWARD AND EXTENDING FROM THE "2" TO OVER THE "T" IN "HEALTH" AND THEN BEHIND THE "T", "L" AND "A" IN "HEALTH" AND HAVING A SPHERE DISPOSED ON THE ARCH OVER THE "H" AND "E" OF "HEALTH", AND WHEREIN THE "2R", THE ARCH AND THE SPHERE ARE IN CONTRAST TO THE "HEALTH" PORTION OF THE MARK.

FOR BAKED NUTRITIONAL WHOLE GRAIN-BASED FOOD BARS FOR THE PURPOSE OF MEAL SUPPLEMENTATION, NAMELY, AS A SIDE DISH AND NOT AS A MEAL REPLACEMENT; BATTER FOR BAKING NUTRITIONAL WHOLE GRAIN-BASED FOOD BARS FOR THE PURPOSE OF MEAL SUPPLEMENTATION (U.S. CL. 46).

TASNEEM HUSSAIN, EXAMINING ATTORNEY

CLASS 30—(Continued).

SN 85-079,346. EXPANSION MANAGEMENT GROUP, LLC, ATLANTA, GA. FILED 7-7-2010.

FLATWICH

THE MARK CONSISTS OF STANDARD CHARACTERS WITHOUT CLAIM TO ANY PARTICULAR FONT, STYLE, SIZE, OR COLOR.

FOR SANDWICHES (U.S. CL. 46).
FIRST USE 6-30-2003; IN COMMERCE 6-30-2003.
HENRY S. ZAK, EXAMINING ATTORNEY

SN 85-089,925. EL ANTOJITO NACIONAL ENTERPRISES, INC., LANSING, IL. FILED 7-21-2010.



NO CLAIM IS MADE TO THE EXCLUSIVE RIGHT TO USE "EL ANTOJITO MORELIANO", APART FROM THE MARK AS SHOWN.

THE COLOR(S) RED, WHITE, GREEN, BLUE, ORANGE, BROWN, YELLOW, BLACK AND GRAY IS/ARE CLAIMED AS A FEATURE OF THE MARK.

THE MARK CONSISTS OF AN ANIMATED CACTUS IN GREEN, BROWN, YELLOW, BLACK AND WHITE, ENCLOSED BY FOUR GRAY PEBBLES, ADORNED WITH A HAT AND HOLDING A TACO IN FRONT OF A MOUNTAINOUS HORIZON WITH A SUNSET IN DESERT LANDSCAPE IN GREEN, BROWN, BLACK, BLUE, WHITE, GRAY, YELLOW AND ORANGE. THE WORDS "EL ANTOJITO" SPREAD IN WHITE WITHIN A RED TOP HALF CIRCLE AND THE WORD "MORELIANO" APPEARS IN WHITE ACROSS THE BOTTOM INSIDE A GREEN RECTANGLE, WITH TWO RED FLOWER FIGURES ON EACH SIDE OF THE WORD "MORELIANO" IN WHITE BACKGROUND.

THE ENGLISH TRANSLATION OF "EL ANTOJITO MORELIANO" IS "THE SNACKS OR APPETIZERS OF MORELIA".

FOR TORTILLA CHIPS, TOSTADAS, CANDY, CANDY BARS, ADOBOS FOR SAUSAGE AND MEATS (U.S. CL. 46).

ELISSA GARBER KON, EXAMINING ATTORNEY

CLASS 30—(Continued).

SN 85-110,269. BRUNO THE RAVIOLI KING, INC., HACKENSACK, NJ. FILED 8-18-2010.



THE MARK CONSISTS OF A RAVIOLI PASTA CHARACTER WEARING A CROWN WITH THE WORD "BRUNO" PRINTED THEREON.

FOR CANNELLONI; DOUGH-ENROBED FOODS CONSISTING OF A DOUGH-BASED WRAPPER WITH FILLINGS CONSISTING PRIMARILY OF MEATS, POULTRY, FISH, FRUITS AND VEGETABLES AND CHEESE; DRIED PASTA; FLOUR-BASED GNOCCHI; FRESH PASTA; LASAGNA; MACARONI; MACARONI; NOODLES; PASTA; PASTA AND NOODLES; PASTA SAUCE; PASTA SHELLS; PESTO; PREPARED PASTA; RAVIOLI; RAVIOLI; SAUCES; SPAGHETTI; SPAGHETTI; SPAGHETTI SAUCE; ZITI; FROZEN, PREPARED AND PACKAGED ENTREES CONSISTING PRIMARILY OF PASTA OR RICE; FROZEN, PREPARED AND PACKAGED MEALS CONSISTING PRIMARILY OF PASTA OR RICE (U.S. CL. 46).

FIRST USE 11-27-1963; IN COMMERCE 11-27-1963.
DAVID TOOLEY, EXAMINING ATTORNEY

SN 85-123,764. INTERSTATE GOURMET COFFEE ROASTERS, INC., SOUTH EASTON, MA. FILED 9-7-2010.

Café Leona

NO CLAIM IS MADE TO THE EXCLUSIVE RIGHT TO USE "CAFE", APART FROM THE MARK AS SHOWN.

THE COLOR(S) RED AND WHITE IS/ARE CLAIMED AS A FEATURE OF THE MARK.

THE MARK CONSISTS OF THE WORDS "CAFE LEONA" IN THE HARRINGTON FONT WITH RED AS THE MAIN COLOR AND WHITE AS AN OUTSIDE STROKE COLOR.

FOR COFFEE (U.S. CL. 46).

FIRST USE 3-18-2009; IN COMMERCE 3-18-2009.

NAKWAMA ANKRAH, EXAMINING ATTORNEY

CLASS 30—(Continued).

SN 85-124,501. THE FITNESS, LLC, YOUNGSTOWN, OH. FILED 9-7-2010.

FEATHERSS

THE MARK CONSISTS OF STANDARD CHARACTERS WITHOUT CLAIM TO ANY PARTICULAR FONT, STYLE, SIZE, OR COLOR.

FOR LOW CALORIE, LIGHTWEIGHT, DISC-SHAPED, INDIVIDUALLY-WRAPPED DARK CHOCOLATES (U.S. CL. 46).

KHANH LE, EXAMINING ATTORNEY

SN 85-125,488. JUICE & ESSENCE, HOBE SOUND, FL. FILED 9-8-2010.

Juice & Essence

THE MARK CONSISTS OF STANDARD CHARACTERS WITHOUT CLAIM TO ANY PARTICULAR FONT, STYLE, SIZE, OR COLOR.

FOR SPICES; SEASONINGS; CONDIMENTS, NAMELY, TROPICAL SALSA, SPAGHETTI SQUASH CHANTERELLE RELISH; SAUCES, NAMELY, MANGO BRANDY CITRUS DRIZZLE, STRAWBERRY LAVENDER SAUCE, BELINI BASTING SAUCE, RASPBERRY CHIPOTLE SAUCE, MEDITERRANEAN VEGETABLE SAUCE, TOMATILLO SAUCE, BEET DRIZZLE, WALNUT CHERRY GLAZE (U.S. CL. 46).

GRETTA YAO, EXAMINING ATTORNEY

SN 85-126,588. NONGSHIM CO., LTD., SEOUL, REPUBLIC OF KOREA, FILED 9-10-2010.



NO CLAIM IS MADE TO THE EXCLUSIVE RIGHT TO USE "SAVORY BOWL NOODLE" AND THE NON-LATIN CHARACTERS THAT TRANSLITERATE TO SABALMYUN, APART FROM THE MARK AS SHOWN.

THE COLOR(S) WHITE, ORANGE, BLUE, YELLOW, RED, AND BLACK IS/ARE CLAIMED AS A FEATURE OF THE MARK.

THE MARK CONSISTS OF THE DESIGN OF A RED CIRCLE HAVING A WHITE TEARDROP LOCATED WITHIN THE TOP HALF THEREOF, THE RED CIRCLE HAVING A WHITE OUTLINE, THE LATIN LETTERS "NONGSHIM" IN WHITE LETTERING LOCATED TO THE RIGHT OF THE

CLASS 30—(Continued).

RED CIRCLE, THE ENGLISH WORD "SAVORY" IN YELLOW LETTERING WITHIN A BLUE BANNER LOCATED BELOW THE WORD "NONGSHIM", THE ENGLISH WORDS "BOWL NOODLE" IN BLUE LETTERING WITH WHITE OUTLINE LOCATED BELOW THE BLUE BANNER, A PROFILE VIEW OF THE BODY OF A CHICKEN IN ORANGE WITH WHITE HACKLES OUTLINED AND WITH MARKINGS IN BLACK LOCATED TO THE RIGHT OF THE WORD "BOWL", AND THE KOREAN CHARACTERS FOR "BOWL NOODLE" IN WHITE LETTERING WITH BLUE OUTLINE LOCATED TO THE RIGHT OF THE WORD "NOODLE", ALL ON AN APPROXIMATELY CIRCULAR BACKGROUND WITH A LIP AT THE BOTTOM, THE BACKGROUND BEING BIASECTED BY A DIAMETER THAT RUNS DIAGONALLY THROUGH THE WORDS "BOWL NOODLE" INTO APPROXIMATELY TWO SEMI-CIRCULAR AREAS HAVING TOP-TO-BOTTOM RECIPROCAL ORANGE-TO-WHITE GRADIENT COLOR. THE DOTTED LINES ARE INTENDED TO SHOW THE POSITION OF THE MARK AND ARE NOT PART OF THE MARK AS SHOWN. THE MARK AS SHOWN MAY FORM THE LID PORTION OF PRODUCT PACKAGING.

THE ENGLISH TRANSLATION OF "NONGSHIM" IN THE MARK IS "HEART OF THE FARMER" AND THE ENGLISH TRANSLATION OF THE KOREAN CHARACTERS IN THE MARK IS "BOWL NOODLE."

THE NON-LATIN CHARACTERS IN THE MARK TRANSLITERATE TO SABALMYUN AND THIS MEANS "BOWL NOODLE" IN ENGLISH.

FOR UNCOOKED NOODLES; RAMEN INSTANT NOODLES; PACKED INSTANT NOODLES; PASTA; CHINESE NOODLES; PROCESSED NOODLES; VERMICELLI NOODLES (U.S. CL. 46).

ANDREA BUTLER, EXAMINING ATTORNEY

SN 85-128,429. I-CANDY INTERNATIONAL, LLC, NEW YORK, NY. FILED 9-13-2010.

TRIPLE LIC-ABLES

THE MARK CONSISTS OF STANDARD CHARACTERS WITHOUT CLAIM TO ANY PARTICULAR FONT, STYLE, SIZE, OR COLOR.

FOR LOLLIPOPS (U.S. CL. 46).

RENEE SERVANCE, EXAMINING ATTORNEY

SN 85-130,907. GOMEZ FAJARDO, FELIPE, ZAPOPAN, JALISCO, MEXICO, FILED 9-16-2010.

HOJUELITAS

THE MARK CONSISTS OF STANDARD CHARACTERS WITHOUT CLAIM TO ANY PARTICULAR FONT, STYLE, SIZE, OR COLOR.

THE ENGLISH TRANSLATION OF "HOJUELITAS" IN THE MARK IS "SMALL LEAVES".

FOR BREAKFAST CEREAL, PROCESSED CEREAL, GRANOLA, AND COOKIES (U.S. CL. 46).

LAURA HAMMEL, EXAMINING ATTORNEY

CLASS 30—(Continued).

SN 85-130,985. GOMEZ FAJARDO, FELIPE, ZAPOPAN, JALISCO, MEXICO, FILED 9-16-2010.

MORDY

THE MARK CONSISTS OF STANDARD CHARACTERS WITHOUT CLAIM TO ANY PARTICULAR FONT, STYLE, SIZE, OR COLOR.

THE WORDING "MORDY" HAS NO MEANING IN A FOREIGN LANGUAGE.

FOR BREAKFAST CEREAL, PROCESSED CEREAL, GRANOLA, COOKIES, AND BISCUITS (U.S. CL. 46).

LAURA HAMMEL, EXAMINING ATTORNEY

CLASS 30—(Continued).

SN 85-139,802. MIRROTEK INTERNATIONAL LLC, PASAIC, NJ. FILED 9-28-2010.

Baker's Apprentice

THE MARK CONSISTS OF STANDARD CHARACTERS WITHOUT CLAIM TO ANY PARTICULAR FONT, STYLE, SIZE, OR COLOR.

NO CLAIM IS MADE TO THE EXCLUSIVE RIGHT TO USE "BAKER'S", APART FROM THE MARK AS SHOWN.

FOR CAKE INGREDIENTS, NAMELY, CAKE MIX, CAKE FROSTING, FONDANT, BUTTERCREAM, NAMELY, BUTTERCREAM FROSTING (U.S. CL. 46).

KATHLEEN LORENZO, EXAMINING ATTORNEY

SN 85-138,094. KHONG GUAN CORPORATION, UNION CITY, CA. FILED 9-24-2010.



THE MARK CONSISTS OF AN OVAL BAND. WITHIN THE OVAL BAND IS THE WORD "RAYA" IN STYLIZED LETTERS. THE LETTER "R" IN "RAYA" IS FURTHER STYLIZED ROUNDING THE TOP OF THE "R" TO SUGGEST A SNOW-COVERED MOUNTAIN PEAK, WITH SNOW SUGGESTED BY A HOLLOW SPACE AT THE TOP OF THE "R". ABOVE THE LETTER "R" IS A NARROW FINIAL SUGGESTING A MOSQUE'S MINARET. TO THE RIGHT OF THE LETTER "R" AND ABOVE THE REMAINING LETTERS "AYA" ARE FIVE EXPLODING FIREWORK DESIGNS UTILIZING SHADED CIRCLES AND LINES FORMING A CIRCULAR FIREWORK. THE WHITE BACKGROUND IS NOT PART OF THE MARK.

THE WORDING "RAYA" HAS NO MEANING IN A FOREIGN LANGUAGE.

FOR ASIAN NOODLES; BUNS; CHILI SAUCE; CHINESE NOODLES; CONDIMENT, NAMELY, PEPPER SAUCE; CURRY PASTES; CURRY POWDER; HOT SAUCE; NOODLES; PANCAKES; PASTA AND NOODLES; SAUCE MIXES; SAUCES (U.S. CL. 46).

FIRST USE 3-1-2004; IN COMMERCE 3-1-2004.
RENEE SERVANCE, EXAMINING ATTORNEY

SN 85-142,514. FERRERO S.P.A., ALBA, CUNEO, ITALY, FILED 9-30-2010.



OWNER OF U.S. REG. NOS. 953,894, 1,102,282 AND 1,390,123.

THE MARK CONSISTS OF A THREE-DIMENSIONAL OVAL SHAPED CANDY WITH SLIGHTLY FLATTENED SIDES AND ROUNDED EDGES. COLOR IS NOT CLAIMED AS A FEATURE OF THE MARK. THE SHADING DOES NOT INDICATE COLOR, BUT RATHER EMPHASIZES THE THREE-DIMENSIONAL QUALITY OF THE MARK.

SEC. 2(F).

FOR CANDY MINTS (U.S. CL. 46).

FIRST USE 0-0-1968; IN COMMERCE 0-0-1970.

GINA FINK, EXAMINING ATTORNEY

CLASS 30—(Continued).

SN 85-142,706. CALDERON, FRANCISCO E, WESTON, FL.
FILED 9-30-2010.

Ohriko

THE MARK CONSISTS OF STANDARD CHARACTERS WITHOUT CLAIM TO ANY PARTICULAR FONT, STYLE, SIZE, OR COLOR.

THE ENGLISH TRANSLATION OF "OHRIKO" IN THE MARK IS "OH HOW GOOD".

FOR ICES AND ICE CREAMS (U.S. CL. 46).
FIRST USE 10-1-2007; IN COMMERCE 7-1-2008.
JOHN DWYER, EXAMINING ATTORNEY

SN 85-144,489. NONG SHIM CO., LTD., SEOUL, REPUBLIC OF KOREA, FILED 10-4-2010.



OWNER OF U.S. REG. NOS. 2,674,488, 3,326,320 AND OTHERS.

THE COLOR(S) RED, WHITE, AND BLACK IS/ARE CLAIMED AS A FEATURE OF THE MARK.

THE MARK CONSISTS OF A RED CIRCLE DEVICE WITH A WHITE INNER CIRCLE; THE WORDS "NONGSHIM" IN BLACK APPEAR UNDERNEATH THE RED CIRCLE DEVICE.

THE ENGLISH TRANSLATION OF NONGSHIM IS "HEART OF THE FARMER".

FOR INSTANT NOODLES; RICE-BASED SNACK FOODS, FLOUR-BASED SNACK FOODS; INSTANT RICE (U.S. CL. 46).

FIRST USE 3-19-1984; IN COMMERCE 1-16-1990.
ANDREA BUTLER, EXAMINING ATTORNEY

SN 85-144,953. MASSIMO ZANETTI BEVERAGE USA, INC., PORTSMOUTH, VA. FILED 10-5-2010.

REVEILLE

THE MARK CONSISTS OF STANDARD CHARACTERS WITHOUT CLAIM TO ANY PARTICULAR FONT, STYLE, SIZE, OR COLOR.

FOR COFFEE; COFFEE BEANS; GREEN COFFEE; GROUND COFFEE BEANS; INSTANT COFFEE; PREPARED COFFEE AND COFFEE-BASED BEVERAGES (U.S. CL. 46).

FIRST USE 9-15-2010; IN COMMERCE 9-15-2010.
ESTHER A. BORSUK, EXAMINING ATTORNEY

CLASS 30—(Continued).

SN 85-168,104. GENERAL MILLS IP HOLDINGS II, LLC, MINNEAPOLIS, MN. FILED 11-3-2010.

FIBER ONE

THE MARK CONSISTS OF STANDARD CHARACTERS WITHOUT CLAIM TO ANY PARTICULAR FONT, STYLE, SIZE, OR COLOR.

OWNER OF U.S. REG. NOS. 1,335,787, 3,554,995 AND OTHERS.

NO CLAIM IS MADE TO THE EXCLUSIVE RIGHT TO USE "FIBER", APART FROM THE MARK AS SHOWN.

FOR PITA BREAD; SANDWICH WRAPS, NAMELY, TORTILLAS (U.S. CL. 46).

MATTHEW MCDOWELL, EXAMINING ATTORNEY

SN 85-169,616. CHOCOLATE DIVE, INC., THE, QUINCY, MA. FILED 11-4-2010.

PUREFECTIONS

THE MARK CONSISTS OF STANDARD CHARACTERS WITHOUT CLAIM TO ANY PARTICULAR FONT, STYLE, SIZE, OR COLOR.

FOR SWEETS, CANDY, CHOCOLATES, BAKERY GOODS AND COOKIES (U.S. CL. 46).

FIRST USE 6-0-2011; IN COMMERCE 6-0-2011.

KATHERINE CHANG, EXAMINING ATTORNEY

SN 85-172,221. LOS BAGELS COMPANY INC., DBA LOS BAGELS, ARCATA, CA. FILED 11-9-2010.

SLUG SLIME

THE MARK CONSISTS OF STANDARD CHARACTERS WITHOUT CLAIM TO ANY PARTICULAR FONT, STYLE, SIZE, OR COLOR.

FOR BAKING SPICES; DRY SPICE RUB FOR MEATS AND FISH; EDIBLE SPICES; SPICE BLENDS; SPICE RUBS; SPICES (U.S. CL. 46).

FIRST USE 3-0-1984; IN COMMERCE 3-0-1984.

GENE MACIOL, EXAMINING ATTORNEY

CLASS 30—(Continued).

SN 85-172,527. SMALL PLANET FOODS, INC., MINNEAPOLIS, MN. FILED 11-9-2010.

MUIR GLEN

THE MARK CONSISTS OF STANDARD CHARACTERS WITHOUT CLAIM TO ANY PARTICULAR FONT, STYLE, SIZE, OR COLOR.

OWNER OF U.S. REG. NOS. 1,665,958 AND 3,101,872. THE NAME(S), PORTRAIT(S), AND/OR SIGNATURE(S) SHOWN IN THE MARK DOES NOT IDENTIFY A PARTICULAR LIVING INDIVIDUAL.
FOR SALSA (U.S. CL. 46).
FIRST USE 12-31-1995; IN COMMERCE 12-31-1995.
JOSETTE BEVERLY, EXAMINING ATTORNEY

SN 85-173,372. WELLS ENTERPRISES, INC., LE MARS, IA. FILED 11-10-2010.

CHOCOLATE LOVERS TRIPLE CHOCOLATE CAKE

THE MARK CONSISTS OF STANDARD CHARACTERS WITHOUT CLAIM TO ANY PARTICULAR FONT, STYLE, SIZE, OR COLOR.

NO CLAIM IS MADE TO THE EXCLUSIVE RIGHT TO USE "CHOCOLATE" AND "TRIPLE CHOCOLATE CAKE", APART FROM THE MARK AS SHOWN.
FOR FROZEN CONFECTIONS (U.S. CL. 46).
ROBERT C. CLARK JR., EXAMINING ATTORNEY

SN 85-177,689. CUMBERLAND PACKING CORP., BROOKLYN, NY. FILED 11-16-2010.

FLOUR IN THE RAW

THE MARK CONSISTS OF STANDARD CHARACTERS WITHOUT CLAIM TO ANY PARTICULAR FONT, STYLE, SIZE, OR COLOR.

OWNER OF U.S. REG. NOS. 937,695, 2,643,110 AND OTHERS.
NO CLAIM IS MADE TO THE EXCLUSIVE RIGHT TO USE "FLOUR", APART FROM THE MARK AS SHOWN.
FOR FLOUR (U.S. CL. 46).
REBECCA EISINGER, EXAMINING ATTORNEY

CLASS 30—(Continued).

SN 85-198,509. GSBL PRODUCTIONS, INC., SAN FRANCISCO, CA. FILED 12-15-2010.

SIXTH COURSE

THE MARK CONSISTS OF STANDARD CHARACTERS WITHOUT CLAIM TO ANY PARTICULAR FONT, STYLE, SIZE, OR COLOR.

FOR CANDIES; CARAMELS; CHOCOLATE TRUFFLES; PRALINES; SWEETS (U.S. CL. 46).
FIRST USE 4-24-2010; IN COMMERCE 4-24-2010.
JENNIFER DIXON, EXAMINING ATTORNEY

SN 85-203,070. NATIONAL IMPORTERS INC., RICHMOND, BC, CANADA, FILED 12-21-2010.



PRIORITY CLAIMED UNDER SEC. 44(D) ON CANADA APPLICATION NO. 1504588, FILED 11-26-2010.

THE MARK CONSISTS OF THE WORD "TIAN" IN STYLIZED FONT WITH THE LETTER "I" BEING FORMED IN PART BY A TEA LEAF.

THE ENGLISH TRANSLATION OF THE WORD "TIAN" IN THE MARK IS "SKY".
FOR TEA (U.S. CL. 46).
FIRST USE 12-19-2009; IN COMMERCE 12-19-2009.
DAVID TAYLOR, EXAMINING ATTORNEY

SN 85-205,724. UNILEVER SUPPLY CHAIN, INC., CLINTON, CT. FILED 12-26-2010.

CORNETTO

THE MARK CONSISTS OF STANDARD CHARACTERS WITHOUT CLAIM TO ANY PARTICULAR FONT, STYLE, SIZE, OR COLOR.

THE ENGLISH TRANSLATION OF "CORNETTO" IN THE MARK IS "CROISSANT".
FOR FROZEN CONFECTIONARY, FROZEN YOGURT AND ICE CREAM (U.S. CL. 46).
ANNE MADDEN, EXAMINING ATTORNEY

CLASS 30—(Continued).

SN 85-207,527. UNITED AMERICAN INDUSTRIES, INC., GILBERT, AZ. FILED 12-29-2010.

SUGARLEAF

THE MARK CONSISTS OF STANDARD CHARACTERS WITHOUT CLAIM TO ANY PARTICULAR FONT, STYLE, SIZE, OR COLOR.

OWNER OF U.S. REG. NO. 3,701,042.

FOR NATURAL SWEETENERS; SUGAR SUBSTITUTES; SUGAR FREE SWEETS; SUGARLESS SWEETS; EXTRACTS USED AS FLAVORING; FLAVOR ENHANCERS USED IN FOOD AND BEVERAGE PRODUCTS; FLAVORING ADDITIVES FOR NON-NUTRITIONAL PURPOSES; FLAVORINGS FOR BEVERAGES; FLAVORINGS FOR FOODS; FLAVORINGS, OTHER THAN ESSENTIAL OILS, FOR CAKES; FLAVORING SYRUP; FOOD ADDITIVES FOR NON-NUTRITIONAL PURPOSES FOR USE AS A FLAVORING; HONEY SUBSTITUTES; TOPPING SYRUP (U.S. CL. 46).

JOHN DALIER, EXAMINING ATTORNEY

SN 85-231,733. CHECKERS DRIVE-IN RESTAURANTS, INC., TAMPA, FL. FILED 2-1-2011.

BBQZILLA

THE MARK CONSISTS OF STANDARD CHARACTERS WITHOUT CLAIM TO ANY PARTICULAR FONT, STYLE, SIZE, OR COLOR.

FOR HAMBURGER SANDWICHES (U.S. CL. 46).

FIRST USE 2-17-2011; IN COMMERCE 2-17-2011.

WON TEAK OH, EXAMINING ATTORNEY

SN 85-231,734. CHECKERS DRIVE-IN RESTAURANTS, INC., TAMPA, FL. FILED 2-1-2011.

MEGAZILLA

THE MARK CONSISTS OF STANDARD CHARACTERS WITHOUT CLAIM TO ANY PARTICULAR FONT, STYLE, SIZE, OR COLOR.

FOR HAMBURGER SANDWICHES (U.S. CL. 46).

FIRST USE 2-17-2011; IN COMMERCE 2-17-2011.

WON TEAK OH, EXAMINING ATTORNEY

CLASS 30—(Continued).

SN 85-238,984. ICHIBAN SAUCE COMPANY LLC, NEW-BERRY, FL. FILED 2-10-2011.



NO CLAIM IS MADE TO THE EXCLUSIVE RIGHT TO USE "SAUCE COMPANY", APART FROM THE MARK AS SHOWN.

THE MARK CONSISTS OF ONE FISH WITH SCALES ABOVE THE TEXT "ICHIBAN SAUCE COMPANY" AND ONE FISH WITH SCALES BELOW THE TEXT.

THE ENGLISH TRANSLATION OF "ICHIBAN" IN THE MARK IS "THE BEST, NUMBER ONE".

FOR SAUCES (U.S. CL. 46).

FIRST USE 1-12-2011; IN COMMERCE 1-12-2011.

ROSELLE HERRERA, EXAMINING ATTORNEY

SN 85-245,150. VITALICO LLC, SAN MATEO, CA. FILED 2-17-2011.

EXQUINA

THE MARK CONSISTS OF STANDARD CHARACTERS WITHOUT CLAIM TO ANY PARTICULAR FONT, STYLE, SIZE, OR COLOR.

FOR FOOD THICKENING AND BINDING AGENTS MADE OF NATURAL PLANT INGREDIENTS (U.S. CL. 46).

DOUGLAS LEE, EXAMINING ATTORNEY

SN 85-246,786. IT'S A SECRET, INC., MANHATTAN BEACH, CA. FILED 2-18-2011.

Marjorie's Big Ass

THE MARK CONSISTS OF STANDARD CHARACTERS WITHOUT CLAIM TO ANY PARTICULAR FONT, STYLE, SIZE, OR COLOR.

FOR SAUCES (U.S. CL. 46).

DEZMONA MIZELLE, EXAMINING ATTORNEY

CLASS 30—(Continued).

SN 85-255,619. TIME BANDITS, LLC, CHICAGO, IL. FILED 3-2-2011.

DRUNKEN CITRUS MOCHA

THE MARK CONSISTS OF STANDARD CHARACTERS WITHOUT CLAIM TO ANY PARTICULAR FONT, STYLE, SIZE, OR COLOR.

NO CLAIM IS MADE TO THE EXCLUSIVE RIGHT TO USE "CITRUS MOCHA", APART FROM THE MARK AS SHOWN.

FOR ESPRESSO BASED DRINKS (U.S. CL. 46).
FIRST USE 6-5-2010; IN COMMERCE 6-5-2010.
JOHN E. MICHOS, EXAMINING ATTORNEY

SN 85-258,396. THE CANDY CRATE, LLP, RED RIVER, NM. FILED 3-4-2011.

CANDY MOUNTAIN FUDGE

THE MARK CONSISTS OF STANDARD CHARACTERS WITHOUT CLAIM TO ANY PARTICULAR FONT, STYLE, SIZE, OR COLOR.

NO CLAIM IS MADE TO THE EXCLUSIVE RIGHT TO USE "CANDY" AND "FUDGE", APART FROM THE MARK AS SHOWN.

FOR CONFECTIONARIES, NAMELY, CANDY AND FUDGE (U.S. CL. 46).
FIRST USE 5-31-1990; IN COMMERCE 5-31-1990.
LAURIE MAYES, EXAMINING ATTORNEY

CLASS 30—(Continued).

SN 85-258,791. MANGIAMELE, DENA, SAN DIEGO, CA. FILED 3-5-2011.



NO CLAIM IS MADE TO THE EXCLUSIVE RIGHT TO USE "FITNESS", APART FROM THE MARK AS SHOWN.

THE NAME(S), PORTRAIT(S), AND/OR SIGNATURE(S) SHOWN IN THE MARK IDENTIFIES DENA MANGIAMELE, WHOSE CONSENT(S) TO REGISTER IS MADE OF RECORD.

THE COLOR(S) THE COLORS GREEN, ORANGE, BLACK, PURPLE AND YELLOW IS/ARE CLAIMED AS A FEATURE OF THE MARK.

THE MARK CONSISTS OF THE STYLIZED WORDS "DENA'S FUEL FOR FITNESS" IN BLACK FONT WITH AN IMAGE OF A YELLOW AND ORANGE CARROT WITH A WITH GREEN TOP UNDERNEATH THE WORDS AND AN IMAGE OF A GREEN LEAF WITH PURPLE VEINS TO THE LEFT OF THE WORDS.

FOR VEGAN FOODS, NAMELY, GRAIN BASED CHIPS, FLOUR BASED CHIPS, COOKIES, CRACKERS, GRANOLA, BREAKFAST CEREALS, AND GRANOLA BASED SNACK BARS (U.S. CL. 46).

FIRST USE 10-1-2010; IN COMMERCE 10-1-2010.
LINDA MICKLEBURGH, EXAMINING ATTORNEY

SN 85-259,125. OSTREICHER, DAVID, LEVITTOWN, NY. FILED 3-6-2011.

AlignMint Chewing Gum

THE MARK CONSISTS OF STANDARD CHARACTERS WITHOUT CLAIM TO ANY PARTICULAR FONT, STYLE, SIZE, OR COLOR.

NO CLAIM IS MADE TO THE EXCLUSIVE RIGHT TO USE "CHEWING GUM", APART FROM THE MARK AS SHOWN.

FOR SUGARFREE CHEWING GUM (U.S. CL. 46).
MATTHEW PAPPAS, EXAMINING ATTORNEY

CLASS 30—(Continued).

SN 85-259,138. EN-R-G FOODS, LLC, STEAMBOAT SPRINGS, CO. FILED 3-6-2011.



NO CLAIM IS MADE TO THE EXCLUSIVE RIGHT TO USE "HONEY", APART FROM THE MARK AS SHOWN.

THE MARK CONSISTS OF AN ATTACKING BEE IN FRONT OF A MOUNTAIN PEAK BACKGROUND WITH THE WORDS "HONEY STINGER".

FOR GRAIN-BASED FOOD BARS ALSO CONTAINING HONEY; GRAIN-BASED SNACK FOODS; GRANOLA-BASED SNACK BARS; GUMMY CANDIES; HONEY; SNACK FOOD CHEWS MADE PRIMARILY FROM BROWN RICE SYRUP (U.S. CL. 46).

FIRST USE 7-10-2002; IN COMMERCE 7-10-2002.
MATTHEW KLINE, EXAMINING ATTORNEY

CLASS 30—(Continued).

SN 85-266,971. R. TWINING AND COMPANY LIMITED, LONDON, GREAT BRITAIN, FILED 3-15-2011.



OWNER OF U.S. REG. NOS. 556,838 AND 1,255,487.
NO CLAIM IS MADE TO THE EXCLUSIVE RIGHT TO USE "LONDON", THE ROYAL CREST, "BY APPOINTMENT TO HER MAJESTY QUEEN ELIZABETH II", "TEA AND COFFEE MERCHANTS", "AND COMPANY LIMITED, LONDON", AND "ESTD. 1706 216 THE STRAND, LONDON WC2, ENGLAND", APART FROM THE MARK AS SHOWN.

THE MARK CONSISTS OF THE WORDS "TWININGS OF LONDON", A ROYAL CREST FOLLOWED BY THE WORDS "BY APPOINTMENT TO HER MAJESTY QUEEN ELIZABETH II TEA AND COFFEE MERCHANTS R. TWINING AND COMPANY LIMITED, LONDON, AND ESTD. 1706 216 THE STRAND, LONDON WC2, ENGLAND" ALL WITHIN AN OVAL.

FOR TEAS AND HERBAL TEAS (U.S. CL. 46).
FIRST USE 0-0-1973; IN COMMERCE 0-0-1973.
PAUL F. GAST, EXAMINING ATTORNEY

SN 85-264,683. SANCHEZ, KATHLYN N., PLYMOUTH, MN. FILED 3-11-2011.

Bee Free Honee

THE MARK CONSISTS OF STANDARD CHARACTERS WITHOUT CLAIM TO ANY PARTICULAR FONT, STYLE, SIZE, OR COLOR.

NO CLAIM IS MADE TO THE EXCLUSIVE RIGHT TO USE "HONEY", APART FROM THE MARK AS SHOWN.

FOR HONEY SUBSTITUTES (U.S. CL. 46).
FIRST USE 7-1-2010; IN COMMERCE 7-1-2010.
RON FAIRBANKS, EXAMINING ATTORNEY

SN 85-266,991. R. TWINING AND COMPANY LIMITED, LONDON, GREAT BRITAIN, FILED 3-15-2011.



OWNER OF U.S. REG. NOS. 556,838 AND 1,255,487.
NO CLAIM IS MADE TO THE EXCLUSIVE RIGHT TO USE "LONDON", AND "ESTD. 1706 216 THE STRAND, LONDON WC2, ENGLAND", APART FROM THE MARK AS SHOWN.

THE MARK CONSISTS OF THE WORDS "TWININGS OF LONDON", AND "ESTD. 1706 216 THE STRAND, LONDON WC2, ENGLAND" ALL WITHIN AN OVAL.

FOR COFFEE, COCOA, CHOCOLATE (U.S. CL. 46).
FIRST USE 9-0-2006; IN COMMERCE 9-0-2006.
PAUL F. GAST, EXAMINING ATTORNEY

CLASS 30—(Continued).

SN 85-267,002. R. TWINING AND COMPANY LIMITED, LONDON, GREAT BRITAIN, FILED 3-15-2011.

TWININGS OF LONDON

THE MARK CONSISTS OF STANDARD CHARACTERS WITHOUT CLAIM TO ANY PARTICULAR FONT, STYLE, SIZE, OR COLOR.

OWNER OF U.S. REG. NOS. 556,838 AND 1,255,487. NO CLAIM IS MADE TO THE EXCLUSIVE RIGHT TO USE "LONDON", APART FROM THE MARK AS SHOWN. FOR TEAS AND HERBAL TEAS (U.S. CL. 46). FIRST USE 0-0-1973; IN COMMERCE 0-0-1973. PAUL F. GAST, EXAMINING ATTORNEY

SN 85-267,007. R. TWINING AND COMPANY LIMITED, LONDON, GREAT BRITAIN, FILED 3-15-2011.

TWININGS OF LONDON

THE MARK CONSISTS OF STANDARD CHARACTERS WITHOUT CLAIM TO ANY PARTICULAR FONT, STYLE, SIZE, OR COLOR.

OWNER OF U.S. REG. NOS. 556,838 AND 1,255,487. NO CLAIM IS MADE TO THE EXCLUSIVE RIGHT TO USE "LONDON", APART FROM THE MARK AS SHOWN. FOR COFFEE, COCOA, CHOCOLATE (U.S. CL. 46). FIRST USE 9-0-2006; IN COMMERCE 9-0-2006. PAUL F. GAST, EXAMINING ATTORNEY

SN 85-270,785. EEZZR CORPORATION, CORAL SPRINGS, FL. FILED 3-18-2011.

Sun Flower Chocolates

THE MARK CONSISTS OF STANDARD CHARACTERS WITHOUT CLAIM TO ANY PARTICULAR FONT, STYLE, SIZE, OR COLOR.

NO CLAIM IS MADE TO THE EXCLUSIVE RIGHT TO USE "CHOCOLATES", APART FROM THE MARK AS SHOWN. FOR CHOCOLATE TRUFFLES (U.S. CL. 46). FIRST USE 12-20-2010; IN COMMERCE 12-20-2010. DEBRA LEE, EXAMINING ATTORNEY

CLASS 30—(Continued).

SN 85-270,820. DALTON, RYAN A, MURRIETA, CA. FILED S.R. 3-18-2011; AM. P.R. 6-21-2011.

Intazza

THE MARK CONSISTS OF STANDARD CHARACTERS WITHOUT CLAIM TO ANY PARTICULAR FONT, STYLE, SIZE, OR COLOR.

THE WORDING "INTAZZA" HAS NO MEANING IN A FOREIGN LANGUAGE. FOR COFFEE; COFFEE; COFFEE AND TEA; COFFEE EXTRACTS; COFFEE PODS; GROUND COFFEE BEANS; ROASTED COFFEE BEANS; TEA PODS (U.S. CL. 46). FIRST USE 11-17-2010; IN COMMERCE 11-17-2010. MICHAEL WIENER, EXAMINING ATTORNEY

SN 85-272,323. AMY HASTEN MURPHY, GLENDALE, AZ. FILED 3-21-2011.

Yin Yang Yogurt

THE MARK CONSISTS OF STANDARD CHARACTERS WITHOUT CLAIM TO ANY PARTICULAR FONT, STYLE, SIZE, OR COLOR.

NO CLAIM IS MADE TO THE EXCLUSIVE RIGHT TO USE "YOGURT", APART FROM THE MARK AS SHOWN. FOR FROZEN YOGURT (U.S. CL. 46). ROBIN CHOSID, EXAMINING ATTORNEY

CLASS 30—(Continued).

SN 85-272,632. IT'S TEALICIOUS FINE TEAS, TREATS AND TREASURES LLC, FAYETTEVILLE, GA. FILED 3-21-2011.



NO CLAIM IS MADE TO THE EXCLUSIVE RIGHT TO USE "FINE TEAS", APART FROM THE MARK AS SHOWN. THE COLOR(S) BLACK AND GREEN IS/ARE CLAIMED AS A FEATURE OF THE MARK.

THE MARK CONSISTS OF THE STYLIZED WORDING "IT'S TEALICIOUS FINE TEAS, TREATS, AND TREASURES" IN BLACK AND A DESIGN OF A GREEN TEA LEAF APPEARING DIRECTLY ABOVE THE SECOND LETTER "I" IN THE WORD "TEALICIOUS".

FOR ARTIFICIAL COFFEE AND TEA; BEVERAGES MADE OF TEA; BEVERAGES WITH A TEA BASE; BLACK TEA; CHAI TEA; COFFEE AND TEA; DISPOSABLE CUPS WITH A TEA-FILLED POUCH ULTRASONICALLY WELDED TO ONE SIDE OF THE BOTTOM OF THE CUP, WHICH ALLOWS THE NATURAL FIBER POUCH TO FLOAT NEAR THE BOTTOM; FLAVOURINGS OF TEA; FRUIT TEAS; GINSENG TEA; GREEN TEA; HERB TEA; HERBAL TEA; ICED TEA; INSTANT TEA; JAPANESE GREEN TEA; LIME TEA; MIXES IN THE NATURE OF CONCENTRATES, SYRUPS OR POWDERS USED IN THE PREPARATION OF TEA BASED BEVERAGES; OOLONG TEA; SAGE TEA; SYRUPS FOR MAKING TEA; TEA; TEA BAGS; TEA EXTRACTS; TEA FOR INFUSIONS; TEA OF PARCHED POWDER OF BARLEY WITH HUSK (MUGI-CHA); TEA OF SALTY KELP POWDER (KOMBU-CHA); TEA PODS; TEA SUBSTITUTES; TEA-BASED BEVERAGES; TEA-BASED BEVERAGES WITH FRUIT FLAVORING; THEINE-FREE TEA SWEETENED WITH SWEETENERS (U.S. CL. 46).
KELLY BOULTON, EXAMINING ATTORNEY

SN 85-272,779. LSLIHS, LLC, LOS ANGELES, CA. FILED 3-21-2011.

Lizzard's Some Like It Hot Sauce

THE MARK CONSISTS OF STANDARD CHARACTERS WITHOUT CLAIM TO ANY PARTICULAR FONT, STYLE, SIZE, OR COLOR.

NO CLAIM IS MADE TO THE EXCLUSIVE RIGHT TO USE "SAUCE", APART FROM THE MARK AS SHOWN.

FOR HOT SAUCE (U.S. CL. 46).
FIRST USE 2-11-2011; IN COMMERCE 2-12-2011.
KIMBERLY FRYE, EXAMINING ATTORNEY

CLASS 30—(Continued).

SN 85-273,683. PL POPCORN, LLC, FRISCO, TX. FILED 3-22-2011.



NO CLAIM IS MADE TO THE EXCLUSIVE RIGHT TO USE "GOURMET POPCORN AND TREATS!", APART FROM THE MARK AS SHOWN.

THE MARK CONSISTS OF THE STYLIZED WORD "POPARELLA'S" HAVING BOTH OF THE LETTERS "P" CAPITALIZED AND HAVING AN OVERFLOWING BAG OF POPCORN USED AS THE "O" IN THE WORD "POP". THE REMAINING LETTERS ARE ALL LOWER CASE AND USE A PIECE OF POPCORN AS THE APOSTROPHE LOCATED BETWEEN THE "A" AND THE "S"; THE LOWER CASE, CURSIVE WORDS "GOURMET POPCORN AND TREATS!" ARE SITUATED DIRECTLY BENEATH THE LETTERS "PARELLA'S" AND A FEMALE FIGURE HOLDING A STEAMING BAG OF POPCORN IS STANDING TO THE RIGHT OF THE WORDS "POPARELLA'S GOURMET POPCORN AND TREATS!".

FOR SNACK FOODS, NAMELY, POPCORN, GOURMET POPCORN, GOURMET AND PACKAGED CANDY (U.S. CL. 46).

FIRST USE 2-4-2011; IN COMMERCE 2-9-2011.
SIMON TENG, EXAMINING ATTORNEY

SN 85-273,917. BRAGG LIVE FOOD PRODUCTS, SANTA BARBARA, CA. FILED 3-22-2011.

Braggberry

THE MARK CONSISTS OF STANDARD CHARACTERS WITHOUT CLAIM TO ANY PARTICULAR FONT, STYLE, SIZE, OR COLOR.

OWNER OF U.S. REG. NO. 3,638,207.
FOR SALAD DRESSING AND MARINADE MADE FROM A UNIQUE BERRY BLEND OF B-BLUEBERRY, R-RASPBERRY, A-ACAI BERRY, G-GOGI BERRY AND G-GRAPES (U.S. CL. 46).

FIRST USE 3-1-2011; IN COMMERCE 3-1-2011.
JOHN E. MICHOS, EXAMINING ATTORNEY

CLASS 30—(Continued).

SN 85-274,028. WILLIAM R. POWELL, SANTA FE, TX.
FILED 3-22-2011.

HERBAL RED

THE MARK CONSISTS OF STANDARD CHARACTERS WITHOUT CLAIM TO ANY PARTICULAR FONT, STYLE, SIZE, OR COLOR.

OWNER OF U.S. REG. NO. 2,880,546.

NO CLAIM IS MADE TO THE EXCLUSIVE RIGHT TO USE "HERBAL", APART FROM THE MARK AS SHOWN.

SEC. 2(F).

FOR SEASONINGS, NAMELY, DRY SPICE BLEND FOR FOOD (U.S. CL. 46).

FIRST USE 1-2-2003; IN COMMERCE 1-2-2003.

ESTHER A. BORSUK, EXAMINING ATTORNEY

SN 85-274,031. WILLIAM R. POWELL, SANTA FE, TX.
FILED 3-22-2011.

JALAPENO DUSTED

THE MARK CONSISTS OF STANDARD CHARACTERS WITHOUT CLAIM TO ANY PARTICULAR FONT, STYLE, SIZE, OR COLOR.

OWNER OF U.S. REG. NO. 2,896,478.

NO CLAIM IS MADE TO THE EXCLUSIVE RIGHT TO USE "JALAPENO", APART FROM THE MARK AS SHOWN.

SEC. 2(F).

FOR SEASONINGS, NAMELY, DRY SPICE BLEND FOR FOOD (U.S. CL. 46).

FIRST USE 1-2-2003; IN COMMERCE 1-2-2003.

ESTHER A. BORSUK, EXAMINING ATTORNEY

SN 85-274,077. DSD MERCHANDISERS, INC., PLEASANTON, CA. FILED 3-23-2011.

The Nutty Shoppe

THE MARK CONSISTS OF STANDARD CHARACTERS WITHOUT CLAIM TO ANY PARTICULAR FONT, STYLE, SIZE, OR COLOR.

NO CLAIM IS MADE TO THE EXCLUSIVE RIGHT TO USE SHOPPE, APART FROM THE MARK AS SHOWN.

FOR CANDY (U.S. CL. 46).

HEATHER SAPP, EXAMINING ATTORNEY

CLASS 30—(Continued).

SN 85-274,457. SECOND CHANCE COFFEE COMPANY LLC,
WHEATON, IL. FILED 3-23-2011.

Inspired Coffee

THE MARK CONSISTS OF STANDARD CHARACTERS WITHOUT CLAIM TO ANY PARTICULAR FONT, STYLE, SIZE, OR COLOR.

NO CLAIM IS MADE TO THE EXCLUSIVE RIGHT TO USE "COFFEE", APART FROM THE MARK AS SHOWN.

FOR COFFEE (U.S. CL. 46).

FIRST USE 7-16-2009; IN COMMERCE 7-16-2009.

JAY FLOWERS, EXAMINING ATTORNEY

SN 85-274,512. TASTEFULLY SIMPLE, INC., ALEXANDRIA,
MN. FILED 3-23-2011.

CARIBBEAN BEACH BREAD MIX

THE MARK CONSISTS OF STANDARD CHARACTERS WITHOUT CLAIM TO ANY PARTICULAR FONT, STYLE, SIZE, OR COLOR.

NO CLAIM IS MADE TO THE EXCLUSIVE RIGHT TO USE "BREAD MIX", APART FROM THE MARK AS SHOWN.

FOR BREAD MIXES (U.S. CL. 46).

HELENE LIWINSKI, EXAMINING ATTORNEY

SN 85-277,136. TOFFEE TO GO, INC., TAMPA, FL. FILED 3-25-2011.

TOFFEE TO GO

THE MARK CONSISTS OF STANDARD CHARACTERS WITHOUT CLAIM TO ANY PARTICULAR FONT, STYLE, SIZE, OR COLOR.

NO CLAIM IS MADE TO THE EXCLUSIVE RIGHT TO USE "TOFFEE", APART FROM THE MARK AS SHOWN.

FOR TOFFEE (U.S. CL. 46).

FIRST USE 5-2-2002; IN COMMERCE 5-2-2002.

BARBARA GAYNOR, EXAMINING ATTORNEY

CLASS 30—(Continued).

SN 85-277,446. SILVER PALATE KITCHENS, INC., CRESSKILL, NJ. FILED 3-25-2011.

HEART GRAINS

THE MARK CONSISTS OF STANDARD CHARACTERS WITHOUT CLAIM TO ANY PARTICULAR FONT, STYLE, SIZE, OR COLOR.

NO CLAIM IS MADE TO THE EXCLUSIVE RIGHT TO USE "GRAINS", APART FROM THE MARK AS SHOWN.

FOR BAKERY GOODS, BREAD MIXES, BREAKFAST CEREALS, CAKE MIXES, MUFFIN MIXES, CEREAL BASED SNACK FOOD, COOKIES, COOKIE MIXES, CRACKERS, DIPPING SAUCES, DOUGH, DRIED PASTA, ICE CREAM, PANCAKE AND WAFFLE MIXES, NOODLES, PASTA, SAUCE MIXES, SAUCES, SEASONINGS, SPICES (U.S. CL. 46).

MARIA-VICTORIA SUAREZ, EXAMINING ATTORNEY

SN 85-279,132. SHORT 'N SWEETS LLC, CHICAGO, IL. FILED 3-28-2011.

Short 'n Sweets

THE MARK CONSISTS OF STANDARD CHARACTERS WITHOUT CLAIM TO ANY PARTICULAR FONT, STYLE, SIZE, OR COLOR.

FOR BAKED GOODS AND CANDIES, MADE FROM SCRATCH, NAMELY, PIES, CAKES, COOKIES, COOKIE BARS, HAND MADE CHOCOLATES, BREAKFAST PASTRIES, SPECIALTY PASTRIES, BREAD, AND ICE CREAM (U.S. CL. 46).

FIRST USE 11-1-2010; IN COMMERCE 11-1-2010.
KATHY DE JONGE, EXAMINING ATTORNEY

SN 85-280,597. BROOKSIDE FARMS HOMEMADE, CLARKESVILLE, GA. FILED 3-29-2011.

Bellflower Mountain Bakery

THE MARK CONSISTS OF STANDARD CHARACTERS WITHOUT CLAIM TO ANY PARTICULAR FONT, STYLE, SIZE, OR COLOR.

NO CLAIM IS MADE TO THE EXCLUSIVE RIGHT TO USE "BAKERY", APART FROM THE MARK AS SHOWN.

FOR BISCUITS; COOKIES; ROLLS (U.S. CL. 46).
JAMES STEIN, EXAMINING ATTORNEY

CLASS 30—(Continued).

SN 85-280,991. JL BEERS, INC., FARGO, ND. FILED 3-30-2011.

JL BURGER

THE MARK CONSISTS OF STANDARD CHARACTERS WITHOUT CLAIM TO ANY PARTICULAR FONT, STYLE, SIZE, OR COLOR.

OWNER OF U.S. REG. NO. 3,943,622.

NO CLAIM IS MADE TO THE EXCLUSIVE RIGHT TO USE "BURGER", APART FROM THE MARK AS SHOWN.

FOR CHEESEBURGER SANDWICHES; HAMBURGER SANDWICHES (U.S. CL. 46).

FIRST USE 10-26-2009; IN COMMERCE 12-29-2010.

CARYN GLASSER, EXAMINING ATTORNEY

SN 85-281,247. KRONFIELD, KAI R., SAN FRANCISCO, CA. FILED 3-30-2011.

Bacon Crack

THE MARK CONSISTS OF STANDARD CHARACTERS WITHOUT CLAIM TO ANY PARTICULAR FONT, STYLE, SIZE, OR COLOR.

NO CLAIM IS MADE TO THE EXCLUSIVE RIGHT TO USE "BACON", APART FROM THE MARK AS SHOWN.

FOR CHOCOLATE; CHOCOLATE BARS; CHOCOLATE CANDIES; TOFFEE (U.S. CL. 46).

FIRST USE 9-1-2010; IN COMMERCE 9-1-2010.

GINA FINK, EXAMINING ATTORNEY

SN 85-287,030. AMY HASTEN MURPHY, GLENDALE, AZ. FILED 4-5-2011.



NO CLAIM IS MADE TO THE EXCLUSIVE RIGHT TO USE "YOGURT", APART FROM THE MARK AS SHOWN.

THE COLOR(S) RASPBERRY AND PEAR IS/ARE CLAIMED AS A FEATURE OF THE MARK.

THE MARK CONSISTS OF THE WORDING "YIN YANG" IN RASPBERRY COLOR FOLLOWED BY A STYLIZED CHINESE SYMBOL FOR YIN YANG IN PEAR AND RASPBERRY COLORS SITTING ON A PEAR-COLORED SPOON FOLLOWED BY THE WORD "YOGURT" IN PEAR COLOR.

FOR FROZEN YOGURT (U.S. CL. 46).

ROBIN CHOSID, EXAMINING ATTORNEY

CLASS 30—(Continued).

SN 85-287,525. GREENLANDS FARM, LLC, BOLIVIA, NC. FILED 4-6-2011.



THE MARK CONSISTS OF THE WORDING "THE TIPPING CUP" IS CENTERED AT THE TOP WITHIN A BANNER WITH FLOURISHES AROUND IT. THERE IS A DRAWING OF A COLLARED AND CROWNED ELEPHANT RIDING A BICYCLE WITH A TEACUP ON HIS TRUNK AND TEAPOT ON HIS TAIL. THERE IS A WATCH FACE BEHIND THE ELEPHANT. THERE IS AN ORNAMENTAL BORDER AROUND THE ELEPHANT AND WATCH FACE WHICH HAS SWIRL DESIGNS ON IT, ABOVE AND BELOW IT AND HAS HOPS ON THE CORNERS.

FOR COFFEE AND TEA (U.S. CL. 46).
FIRST USE 11-12-2010; IN COMMERCE 2-17-2011.
THOMAS MANOR, EXAMINING ATTORNEY

SN 85-289,828. RICHARD ANDERSON, NASHVILLE, IN. AND MICHAEL WATSON, WESTFIELD, IN. FILED 4-8-2011.

Maystard

THE MARK CONSISTS OF STANDARD CHARACTERS WITHOUT CLAIM TO ANY PARTICULAR FONT, STYLE, SIZE, OR COLOR.

FOR MAYONNAISE; MUSTARD (U.S. CL. 46).
GENE MACIOL, EXAMINING ATTORNEY

SN 85-289,956. TIFF'S TREATS HOLDINGS, INC., AUSTIN, TX. FILED 4-8-2011.

TIFFWICH

THE MARK CONSISTS OF STANDARD CHARACTERS WITHOUT CLAIM TO ANY PARTICULAR FONT, STYLE, SIZE, OR COLOR.

OWNER OF U.S. REG. NOS. 3,083,436 AND 3,847,417.
FOR ICE CREAM SANDWICHES (U.S. CL. 46).
FIRST USE 3-1-2006; IN COMMERCE 3-1-2006.
SHANNON TWOHIG, EXAMINING ATTORNEY

CLASS 30—(Continued).

SN 85-290,897. MAXIM'S NUTRICARE, INC., DBA PAPA PITA BAKERY, SALT LAKE CITY, UT. FILED 4-8-2011.



NO CLAIM IS MADE TO THE EXCLUSIVE RIGHT TO USE "PITA", APART FROM THE MARK AS SHOWN.

THE MARK CONSISTS OF PICTURE OF OLD MAN WITH SPECTACLES IN A ROUND, FLANKED BY EARS OF CORN ON EITHER SIDE WITH A BANNER UNDERNEATH THE ROUND CONTAINING THE WORDS "PAPA PITA".

FOR BREAD (U.S. CL. 46).
FIRST USE 10-1-1982; IN COMMERCE 10-1-1982.
JOHN E. MICHOS, EXAMINING ATTORNEY

SN 85-290,976. GELMAN, LUKAS, DBA BLACK AND BLUE BBQ, CHICAGO, IL. FILED 4-9-2011.



NO CLAIM IS MADE TO THE EXCLUSIVE RIGHT TO USE "BBQ", APART FROM THE MARK AS SHOWN.

THE COLOR(S) BLACK AND BLUE IS/ARE CLAIMED AS A FEATURE OF THE MARK.

THE MARK CONSISTS OF ON THE TOP THERE ARE 2 LINES OF TEXT WHERE THE LETTERS ARE DIFFERENT SIZES CENTERED. THE WORDS ON THE TOP ROW ARE "BLACK & BLUE" AND THE LETTERS ON THE BOTTOM ROW ARE "BBQ" STANDING FOR BARBECUE. THERE IS A FIST UNDER "BBQ" WITH BLACK FINGERS AND THERE ARE BLUE COW STYLED HORNS COMING OUT FROM EITHER SIDE.

FOR BARBEQUE DRY RUB, BARBECUE SAUCE AND PRINTED RECIPES THEREFOR SOLD AS A UNIT, AND BARBEQUE SAUCE (U.S. CL. 46).

PATRICIA EVANKO, EXAMINING ATTORNEY

CLASS 30—(Continued).

SN 85-291,491. FRITO-LAY NORTH AMERICA, INC., PLANO, TX. FILED 4-11-2011.

SIGN OF AN INTELLIGENT LIFE

THE MARK CONSISTS OF STANDARD CHARACTERS WITHOUT CLAIM TO ANY PARTICULAR FONT, STYLE, SIZE, OR COLOR.

FOR POPPED POPCORN (U.S. CL. 46).
FIRST USE 7-21-1995; IN COMMERCE 7-21-1995.
SHARON MEIER, EXAMINING ATTORNEY

SN 85-291,545. ABRAMS, MARK, GRANADA HILLS, CA. FILED 4-11-2011.



THE MARK CONSISTS OF A WILLOW TREE IN A SEMI-CIRCLE WITH THE STYLIZED TEXT "RAINING WILLOWS". BELOW THERE IS THE STYLIZED TEXT "A FLAVOR EXPERIENCE FOR THE WHOLE FAMILY." COMPLETING THE BOTTOM HALF OF THE SEMI-CIRCLE.

FOR SALSA; SAUCES; SPICE RUBS (U.S. CL. 46).
KELLY BOULTON, EXAMINING ATTORNEY

SN 85-291,720. CHRISTINA-CLARE, L.L.C., ALLENDALE, MI. FILED 4-11-2011.



THE MARK CONSISTS OF SMILING YOUNG GIRL WITH CURLY HAIR AND THE NAME "CHRISTINA-CLARE".

FOR BREAD; CAKES; COOKIES; MUFFINS; PIES (U.S. CL. 46).
STEVEN JACKSON, EXAMINING ATTORNEY

CLASS 30—(Continued).

SN 85-291,763. LADYBIRD & FRIENDS LLC, PONTE VEDRA BEACH, FL. FILED 4-11-2011.

HOT BOX

THE MARK CONSISTS OF STANDARD CHARACTERS WITHOUT CLAIM TO ANY PARTICULAR FONT, STYLE, SIZE, OR COLOR.

FOR HOT SAUCE (U.S. CL. 46).
FIRST USE 12-15-2010; IN COMMERCE 12-15-2010.
ASMAT KHAN, EXAMINING ATTORNEY

SN 85-291,867. ROLLINS, SIVONNE, ELMONT, NY. FILED 4-11-2011.

Sweetly Demented

THE MARK CONSISTS OF STANDARD CHARACTERS WITHOUT CLAIM TO ANY PARTICULAR FONT, STYLE, SIZE, OR COLOR.

FOR CANDIES; CANDY WITH CARAMEL; CANDY WITH COCOA; CHOCOLATE CANDIES; CHOCOLATES AND CHOCOLATE BASED READY TO EAT CANDIES AND SNACKS (U.S. CL. 46).

CAROLINE WOOD, EXAMINING ATTORNEY

SN 85-292,155. JOVAN'S PURE NUTRITION, L.L.C., BLAINE, WA. FILED 4-11-2011.

JOVAN'S PURE NUTRITION

THE MARK CONSISTS OF STANDARD CHARACTERS WITHOUT CLAIM TO ANY PARTICULAR FONT, STYLE, SIZE, OR COLOR.

NO CLAIM IS MADE TO THE EXCLUSIVE RIGHT TO USE "NUTRITION", APART FROM THE MARK AS SHOWN.

FOR CRACKERS (U.S. CL. 46).

FIRST USE 2-10-2011; IN COMMERCE 3-7-2011.

DEIRDRE ROBERTSON, EXAMINING ATTORNEY

CLASS 30—(Continued).

SN 85-292,185. JOVAN'S PURE NUTRITION, L.L.C., BLAINE, WA. FILED 4-11-2011.

GIVE YOUR BODY SOMETHING
EXTRAORDINARILY GOOD

THE MARK CONSISTS OF STANDARD CHARACTERS WITHOUT CLAIM TO ANY PARTICULAR FONT, STYLE, SIZE, OR COLOR.

FOR CRACKERS (U.S. CL. 46).
FIRST USE 2-10-2011; IN COMMERCE 3-7-2011.
DEIRDRE ROBERTSON, EXAMINING ATTORNEY

SN 85-292,308. SANTA BARBARA, INC., HOUSTON, TX. FILED 4-11-2011.

EDULZO

THE MARK CONSISTS OF STANDARD CHARACTERS WITHOUT CLAIM TO ANY PARTICULAR FONT, STYLE, SIZE, OR COLOR.

THE WORDING "EDULZO" HAS NO MEANING IN A FOREIGN LANGUAGE.

FOR SUGAR (U.S. CL. 46).
MARK SHINER, EXAMINING ATTORNEY

SN 85-292,352. MAXIM'S NUTRICARE, INC., DBA PAPA PITA BAKERY, SALT LAKE CITY, UT. FILED 4-11-2011.



THE MARK CONSISTS OF STYLIZED WORD "WRAPIDO", WITH A BANNER UNDERNEATH, THREE OVAL DOTS ON CURLED "O" AND A ROLLING PIN ABOVE THE END OF THE LAST THREE LETTERS OF SAID WORD.

FOR BREAD (U.S. CL. 46).
FIRST USE 1-1-2005; IN COMMERCE 1-1-2005.
JOHN E. MICHOS, EXAMINING ATTORNEY

CLASS 30—(Continued).

SN 85-292,372. MAXIM'S NUTRICARE, INC., DBA PAPA PITA BAKERY, SALT LAKE CITY, UT. FILED 4-11-2011.



NO CLAIM IS MADE TO THE EXCLUSIVE RIGHT TO USE "BAGELS", APART FROM THE MARK AS SHOWN.

THE MARK CONSISTS OF IMAGE OF MUSCULAR YOUNG MALE, WEARING A BELT, EATING A BAGEL WITH THE WORDS "BUBBA'S BAGELS" ON THE SLEEVELESS T-SHIRT, THE WORD "BUBBA'S" IN BIG LETTERS LOCATED OVER A BANNER CONTAINING THE WORD "BAGELS".

FOR BREAD AND BAGELS (U.S. CL. 46).
FIRST USE 1-1-1996; IN COMMERCE 1-1-1996.
JOHN E. MICHOS, EXAMINING ATTORNEY

SN 85-292,469. ANDRE PROST, INC., OLD SAYBROOK, CT. FILED 4-12-2011.



OWNER OF U.S. REG. NO. 1,696,339.
THE MARK CONSISTS OF THE STYLIZED WORDS "ENERGYPLUS" IN A RELATIVELY LIGHTER SHADE WITH A RELATIVELY DARKER BACKGROUND/BORDER.

FOR CANDY (U.S. CL. 46).
EMILY CARLSEN, EXAMINING ATTORNEY

SN 85-292,614. ROBINSON, LAMONT, SICKLERVILLE, NJ. FILED 4-12-2011.

The T.I.C. Menu (Turkey In
Charge)

THE MARK CONSISTS OF STANDARD CHARACTERS WITHOUT CLAIM TO ANY PARTICULAR FONT, STYLE, SIZE, OR COLOR.

FOR PIZZA (U.S. CL. 46).
AMY HELLA, EXAMINING ATTORNEY

CLASS 30—(Continued).

SN 85-292,835. DAN LORITZ, GLENDALE, CA. AND GINA TERRONES, GLENDALE, CA. FILED 4-12-2011.

XO MINTS

THE MARK CONSISTS OF STANDARD CHARACTERS WITHOUT CLAIM TO ANY PARTICULAR FONT, STYLE, SIZE, OR COLOR.

NO CLAIM IS MADE TO THE EXCLUSIVE RIGHT TO USE "MINTS", APART FROM THE MARK AS SHOWN. FOR CANDY MINTS (U.S. CL. 46).
JUDITH HELFMAN, EXAMINING ATTORNEY

SN 85-292,842. DAN LORITZ, GLENDALE, CA. AND GINA TERRONES, GLENDALE, CA. FILED 4-12-2011.

THE FLIRTATIOUS MINT

THE MARK CONSISTS OF STANDARD CHARACTERS WITHOUT CLAIM TO ANY PARTICULAR FONT, STYLE, SIZE, OR COLOR.

NO CLAIM IS MADE TO THE EXCLUSIVE RIGHT TO USE "MINT", APART FROM THE MARK AS SHOWN. FOR CANDY MINTS (U.S. CL. 46).
JUDITH HELFMAN, EXAMINING ATTORNEY

SN 85-292,964. PUGZEE'S FARM, LLC, LENOX, MA. FILED 4-12-2011.



NO CLAIM IS MADE TO THE EXCLUSIVE RIGHT TO USE "FARM" AND "WASHINGTON, MASSACHUSETTS", APART FROM THE MARK AS SHOWN.

THE MARK CONSISTS OF A GREEN OVAL SHAPE WITH THE PHRASE "VETERANS HARVESTING HOPE" ABOVE IT AND THE PHRASE "WASHINGTON, MASSACHUSETTS" BELOW IT. THESE PHRASES ARE BOTH FLANKED BY TWO DOTS. THE WORD "PUGZEE'S" IS WITHIN THE OVAL AT THE TOP AND THE WORD "FARM" IS ON THE BOTTOM WITHIN THE OVAL. BETWEEN "PUGZEE'S" AND "FARM" IS A DRAWING OF A PUG STANDING IN THE MIDDLE WITH A DRAWING OF TWO RED APPLES TO ITS LEFT AND A DRAWING OF A HONEYPOT AND DIPPER TO ITS RIGHT.

FOR BAKERY GOODS, HONEY (U.S. CL. 46).
GEOFFREY FOSDICK, EXAMINING ATTORNEY

CLASS 30—(Continued).

SN 85-293,259. TEAM CANDY SUCKERS, LLC, MOUNT PLEASANT, SC. FILED 4-12-2011.

VICTORY NEVER TASTED SO SWEET

THE MARK CONSISTS OF STANDARD CHARACTERS WITHOUT CLAIM TO ANY PARTICULAR FONT, STYLE, SIZE, OR COLOR.

FOR LOLLIPOPS (U.S. CL. 46).
FIRST USE 9-1-2010; IN COMMERCE 9-1-2010.
DAVID COLLIER, EXAMINING ATTORNEY

SN 85-293,270. PUGZEE'S FARM, LLC, LENOX, MA. FILED 4-12-2011.



NO CLAIM IS MADE TO THE EXCLUSIVE RIGHT TO USE "FARM" AND "WASHINGTON, MASSACHUSETTS", APART FROM THE MARK AS SHOWN.

THE COLOR(S) GREEN, RED, GREY, BEIGE, WHITE AND BROWN IS/ARE CLAIMED AS A FEATURE OF THE MARK.

THE MARK CONSISTS OF A GREEN OVAL SHAPE WITH THE PHRASE "VETERANS HARVESTING HOPE" ABOVE IT AND THE PHRASE "WASHINGTON, MASSACHUSETTS" BELOW IT, BOTH IN GREEN LETTERING. THESE PHRASES ARE BOTH FLANKED BY TWO GREEN DOTS. THE WORD "PUGZEE'S" IN WHITE IS WITHIN THE OVAL AT THE TOP AND THE WORD "FARM" IN WHITE IS ON THE BOTTOM WITHIN THE OVAL. BETWEEN "PUGZEE'S" AND "FARM" IS A DRAWING OF A GREY PUG STANDING IN THE MIDDLE WITH A DRAWING OF TWO RED APPLES WITH GREEN LEAVES AND GREY STEM TO ITS LEFT AND A DRAWING OF A BEIGE AND BROWN HONEYPOT AND A BEIGE DIPPER TO ITS RIGHT.

FOR BAKERY GOODS, HONEY (U.S. CL. 46).
GEOFFREY FOSDICK, EXAMINING ATTORNEY

CLASS 30—(Continued).

SN 85-294,168. HILL COUNTRY BAKERY, LLC, SAN ANTONIO, TX. FILED 4-13-2011.

EONI

THE MARK CONSISTS OF STANDARD CHARACTERS WITHOUT CLAIM TO ANY PARTICULAR FONT, STYLE, SIZE, OR COLOR.
FOR COFFEE CAKES (U.S. CL. 46).
FIRST USE 3-4-2011; IN COMMERCE 3-4-2011.
DOMINICK J. SALEMI, EXAMINING ATTORNEY

SN 85-294,182. HILL COUNTRY BAKERY, LLC, SAN ANTONIO, TX. FILED 4-13-2011.

**EARTH'S OWN NATURAL
INGREDIENTS**

THE MARK CONSISTS OF STANDARD CHARACTERS WITHOUT CLAIM TO ANY PARTICULAR FONT, STYLE, SIZE, OR COLOR.
FOR COFFEE CAKES (U.S. CL. 46).
FIRST USE 3-4-2011; IN COMMERCE 3-4-2011.
DOMINICK J. SALEMI, EXAMINING ATTORNEY

SN 85-294,219. TERRY HARRIS, CORDOVA, TN. FILED 4-13-2011.

UP SNAX ENERGY

THE MARK CONSISTS OF STANDARD CHARACTERS WITHOUT CLAIM TO ANY PARTICULAR FONT, STYLE, SIZE, OR COLOR.
FOR BROWNIES; COOKIES; SNACK CAKES (U.S. CL. 46).
GIANCARLO CASTRO, EXAMINING ATTORNEY

CLASS 30—(Continued).

SN 85-294,417. ALEXANDER L. BILLAN, PARANAQUE, METRO MANILA, PHILIPPINES, FILED 4-13-2011.

**ONCE TASTED EVER WANTED
...!**

THE MARK CONSISTS OF STANDARD CHARACTERS WITHOUT CLAIM TO ANY PARTICULAR FONT, STYLE, SIZE, OR COLOR.
FOR NOODLES, NAMELY, RICE STICKS AND FLOUR STICKS (U.S. CL. 46).
FIRST USE 2-1-1982; IN COMMERCE 2-1-1982.
WILLIAM VERHOSEK, EXAMINING ATTORNEY

SN 85-294,579. BEE LINE, INC., WOODLAND HILLS, CA. FILED 4-13-2011.



THE NAME "LAILA ALI" IDENTIFIES A LIVING INDIVIDUAL WHOSE CONSENT IS OF RECORD.
THE MARK CONSISTS OF LAILA ALI'S SIGNATURE.
FOR MARINADES; SALAD DRESSINGS; SALSA; SAUCES; SEASONINGS; SPICES (U.S. CL. 46).
ALEX KEAM, EXAMINING ATTORNEY

SN 85-294,592. BEE LINE, INC., WOODLAND HILLS, CA. FILED 4-13-2011.

LAILA ALI

THE MARK CONSISTS OF STANDARD CHARACTERS WITHOUT CLAIM TO ANY PARTICULAR FONT, STYLE, SIZE, OR COLOR.
THE NAME "LAILA ALI" IDENTIFIES A LIVING INDIVIDUAL WHOSE CONSENT IS OF RECORD.
FOR MARINADES; SALAD DRESSINGS; SALSA; SAUCES; SEASONINGS; SPICES (U.S. CL. 46).
ALEX KEAM, EXAMINING ATTORNEY

CLASS 30—(Continued).

SN 85-295,404. UNCLE WALLY'S LLC, SHIRLEY, NY. FILED 4-14-2011.

FUN MUFFINS

THE MARK CONSISTS OF STANDARD CHARACTERS WITHOUT CLAIM TO ANY PARTICULAR FONT, STYLE, SIZE, OR COLOR.

NO CLAIM IS MADE TO THE EXCLUSIVE RIGHT TO USE "MUFFINS", APART FROM THE MARK AS SHOWN. FOR MUFFINS (U.S. CL. 46).

DAVID H. STINE, EXAMINING ATTORNEY

SN 85-295,617. OOGIE'S SNACKS, LLC, DENVER, CO. FILED 4-14-2011.

STIX & STONZ

THE MARK CONSISTS OF STANDARD CHARACTERS WITHOUT CLAIM TO ANY PARTICULAR FONT, STYLE, SIZE, OR COLOR.

FOR SNACK MIX CONSISTING PRIMARILY OF CRACKERS, PRETZELS AND/OR POPPED POPCORN (U.S. CL. 46).

CARYN GLASSER, EXAMINING ATTORNEY

SN 85-297,790. GRUMA CORPORATION, IRVING, TX. FILED 4-18-2011.



OWNER OF U.S. REG. NOS. 3,778,071, 3,798,895 AND OTHERS.

NO CLAIM IS MADE TO THE EXCLUSIVE RIGHT TO USE "CALIDAD Y FRESCURA", APART FROM THE MARK AS SHOWN.

THE COLOR(S) RED, GREEN, YELLOW AND WHITE IS/ARE CLAIMED AS A FEATURE OF THE MARK.

THE MARK CONSISTS OF A CIRCLE DESIGN THE OUTER PERIMETER OF WHICH CONSISTS OF FOUR BANDS: ONE YELLOW, ONE RED, ONE YELLOW AND ONE GREEN. THE WORDS "CALIDAD Y FRESCURA" ARE IN WHITE ACROSS THE TOP OF THE UPPER PART OF THE RED BAND. IN THE UPPER HALF OF THE INTERIOR

CLASS 30—(Continued).

OF THE CIRCLE IS A PHOTOGRAPH OF PART OF AN EAR OF CORN WHICH IS YELLOW WITH GREEN LEAVES ON EITHER SIDE OF THE EAR OF CORN. THE LOWER HALF OF THE INTERIOR CIRCLE IS YELLOW WITH THE WORDS "UN PEDACITO DE MEXICO" IN GREEN ACROSS THE TOP. ACROSS THE MIDDLE OF THE CIRCLE IS A WHITE BANNER OUTLINED IN GREEN WITH THE WORD "GUERRERO" IN STYLIZED GREEN LETTERS. THERE IS A GREEN STRIPE ACROSS THE TOP AND BOTTOM OF THE BANNER.

THE ENGLISH TRANSLATION OF "CALIDAD Y FRESCURA", "GUERRERO" AND "UN PEDACITO DE MEXICO" IN THE MARK IS "QUALITY AND FRESHNESS", "WARRIOR" AND "A LITTLE PIECE OF MEXICO".

FOR TORTILLAS, TOSTADAS (U.S. CL. 46).

FIRST USE 10-0-2008; IN COMMERCE 10-0-2008.

WILLIAM P. SHANAHAN, EXAMINING ATTORNEY

SN 85-298,987. MCDONALD'S CORPORATION, OAK BROOK, IL. FILED 4-19-2011.

MCCHICKEN

THE MARK CONSISTS OF STANDARD CHARACTERS WITHOUT CLAIM TO ANY PARTICULAR FONT, STYLE, SIZE, OR COLOR.

OWNER OF U.S. REG. NOS. 1,065,885 AND 1,481,974.

FOR CHICKEN SANDWICHES (U.S. CL. 46).

FIRST USE 6-16-1975; IN COMMERCE 6-16-1975.

DAVID COLLIER, EXAMINING ATTORNEY

SN 85-300,646. WYSTONE'S WORLD TEAS IP, LLC, CASTLE ROCK, CO. FILED 4-21-2011.

BOS KOEKIE

THE MARK CONSISTS OF STANDARD CHARACTERS WITHOUT CLAIM TO ANY PARTICULAR FONT, STYLE, SIZE, OR COLOR.

NO CLAIM IS MADE TO THE EXCLUSIVE RIGHT TO USE "KOEKIE", APART FROM THE MARK AS SHOWN.

THE ENGLISH TRANSLATION OF "BOS KOEKIE" IN THE MARK IS "FOREST COOKIE".

FOR COOKIES (U.S. CL. 46).

FIRST USE 2-13-2011; IN COMMERCE 2-13-2011.

LESLEY LAMOTHE, EXAMINING ATTORNEY

CLASS 30—(Continued).

SN 85-302,525. SOREMARTEC S.A., ARLON, BELGIUM, FILED 4-22-2011.



OWNER OF U.S. REG. NOS. 983,418, 3,300,496 AND OTHERS.

THE COLOR(S) GREEN, BROWN, GRAY AND WHITE IS/ARE CLAIMED AS A FEATURE OF THE MARK.

THE MARK CONSISTS OF THE WORDS "TIC TAC" IN WHITE INSIDE A GRAPHIC LEAF DESIGN IN GREEN AND OUTLINED IN WHITE WITH A GRAY SHADOW; BELOW THE LEAF DESIGN THE WORD "CHOCs" IN BROWN LETTERING WITH GRAY AND WHITE BORDERS APPEARS.

FOR CANDY (U.S. CL. 46).

PATRICIA EVANKO, EXAMINING ATTORNEY

CLASS 30—(Continued).

SN 85-305,104. LANCE MFG. LLC, CHARLOTTE, NC. FILED 4-26-2011.



OWNER OF U.S. REG. NOS. 1,668,706, 1,671,959 AND 2,452,523.

NO CLAIM IS MADE TO THE EXCLUSIVE RIGHT TO USE "HOMESTYLE COOKIES", APART FROM THE MARK AS SHOWN.

THE MARK CONSISTS OF AN OBLONG DESIGN, FLAT ON EACH END AND ROUNDED ON TOP AND BOTTOM, WITH THE WORD "ARCHWAY" IN LARGER FONT CENTERED INSIDE, THE WORD "HOMESTYLE" IN SMALLER FONT ON TOP INSIDE AND THE WORD "COOKIES" IN SMALLER FONT ON BOTTOM INSIDE.

FOR COOKIES (U.S. CL. 46).

ROBERT C. CLARK JR., EXAMINING ATTORNEY

SN 85-307,022. WAL-MART STORES, INC., BENTONVILLE, AR. FILED 4-28-2011.

SWITCH-A-ROOS

THE MARK CONSISTS OF STANDARD CHARACTERS WITHOUT CLAIM TO ANY PARTICULAR FONT, STYLE, SIZE, OR COLOR.

FOR COOKIES (U.S. CL. 46).

CORY BOONE, EXAMINING ATTORNEY

SN 85-303,366. OOGIE'S SNACKS, LLC, DENVER, CO. FILED 4-25-2011.

STICKS & STONEZ

THE MARK CONSISTS OF STANDARD CHARACTERS WITHOUT CLAIM TO ANY PARTICULAR FONT, STYLE, SIZE, OR COLOR.

FOR SNACK MIX CONSISTING PRIMARILY OF CRACKERS, PRETZELS AND/OR POPPED POPCORN (U.S. CL. 46).

CARYN GLASSER, EXAMINING ATTORNEY

SN 85-308,455. LANCE MFG. LLC, CHARLOTTE, NC. FILED 4-29-2011.

HOMEKIST

THE MARK CONSISTS OF STANDARD CHARACTERS WITHOUT CLAIM TO ANY PARTICULAR FONT, STYLE, SIZE, OR COLOR.

OWNER OF U.S. REG. NO. 2,337,901.

FOR CRACKERS (U.S. CL. 46).

FIRST USE 10-26-1998; IN COMMERCE 10-26-1998.

ROBERT C. CLARK JR., EXAMINING ATTORNEY

CLASS 30—(Continued).

SN 85-308,464. LANCE MFG. LLC, CHARLOTTE, NC. FILED 4-29-2011.

HOMEKIST

THE MARK CONSISTS OF STANDARD CHARACTERS WITHOUT CLAIM TO ANY PARTICULAR FONT, STYLE, SIZE, OR COLOR.

OWNER OF U.S. REG. NO. 2,337,901.
FOR COOKIES (U.S. CL. 46).
ROBERT C. CLARK JR., EXAMINING ATTORNEY

SN 85-308,487. LANCE MFG. LLC, CHARLOTTE, NC. FILED 4-29-2011.



OWNER OF U.S. REG. NO. 2,337,901.
THE MARK CONSISTS OF THE WORD "HOMEKIST" IN AN UPWARD DIRECTION, OUTLINED, WITH DUAL HEARTS DOTTING THE "I".
FOR COOKIES AND CRACKERS (U.S. CL. 46).
ROBERT C. CLARK JR., EXAMINING ATTORNEY

SN 85-312,966. FARLEY'S & SATHERS CANDY COMPANY, INC., ROUND LAKE, MN. FILED 5-5-2011.

PEANUT BUTTER POPPINS

THE MARK CONSISTS OF STANDARD CHARACTERS WITHOUT CLAIM TO ANY PARTICULAR FONT, STYLE, SIZE, OR COLOR.

NO CLAIM IS MADE TO THE EXCLUSIVE RIGHT TO USE "PEANUT BUTTER", APART FROM THE MARK AS SHOWN.

FOR CANDY (U.S. CL. 46).
FIRST USE 1-1-2011; IN COMMERCE 1-1-2011.
KAREN BRACEY, EXAMINING ATTORNEY

CLASS 30—(Continued).

SN 85-313,069. WHOLE FOODS MARKET IP, L.P., AUSTIN, TX. FILED 5-5-2011.

WHOLE PLANET FOUNDATION

THE MARK CONSISTS OF STANDARD CHARACTERS WITHOUT CLAIM TO ANY PARTICULAR FONT, STYLE, SIZE, OR COLOR.

OWNER OF U.S. REG. NOS. 3,410,427, 3,577,894 AND OTHERS.
FOR SPICES, SPICE BLENDS, FOOD SEASONINGS AND FOOD FLAVORINGS; PROCESSED HERBS (U.S. CL. 46).
MARY CRAWFORD, EXAMINING ATTORNEY

SN 85-313,154. HOMEBOY INDUSTRIES, LOS ANGELES, CA. FILED 5-5-2011.

HOMEBOY

THE MARK CONSISTS OF STANDARD CHARACTERS WITHOUT CLAIM TO ANY PARTICULAR FONT, STYLE, SIZE, OR COLOR.

OWNER OF U.S. REG. NOS. 2,775,900, 3,376,965 AND OTHERS.
FOR SALSA; CORN, TACO, TORTILLA AND FLOUR-BASED CHIPS; MOLE AND TACO SAUCES (U.S. CL. 46).
DOMINICK J. SALEMI, EXAMINING ATTORNEY

SN 85-313,162. HOMEBOY INDUSTRIES, LOS ANGELES, CA. FILED 5-5-2011.



OWNER OF U.S. REG. NOS. 2,775,900, 3,376,965 AND OTHERS.

THE MARK CONSISTS OF THE WORD "HOMEBOY" PRESENTED IN A STYLIZED FORMAT INSIDE OF AN IRREGULARLY SHAPED BOX BORDER.

FOR SALSA; CORN, TACO, TORTILLA AND FLOUR-BASED CHIPS; MOLE AND TACO SAUCES (U.S. CL. 46).
DOMINICK J. SALEMI, EXAMINING ATTORNEY

CLASS 30—(Continued).

SN 85-313,501. PEPPERIDGE FARM, INCORPORATED, NORWALK, CT. FILED 5-5-2011.

MAUI

THE MARK CONSISTS OF STANDARD CHARACTERS WITHOUT CLAIM TO ANY PARTICULAR FONT, STYLE, SIZE, OR COLOR.
FOR COOKIES (U.S. CL. 46).
CHRISTINA SOBRAL, EXAMINING ATTORNEY

SN 85-313,512. PEPPERIDGE FARM, INCORPORATED, NORWALK, CT. FILED 5-5-2011.

LEXINGTON

THE MARK CONSISTS OF STANDARD CHARACTERS WITHOUT CLAIM TO ANY PARTICULAR FONT, STYLE, SIZE, OR COLOR.
FOR COOKIES (U.S. CL. 46).
CHRISTINA SOBRAL, EXAMINING ATTORNEY

SN 85-314,155. FERRARA PAN CANDY CO., INC., FOREST PARK, IL. FILED 5-6-2011.

FROSTY CHEWY LEMONHEAD & FRIENDS

THE MARK CONSISTS OF STANDARD CHARACTERS WITHOUT CLAIM TO ANY PARTICULAR FONT, STYLE, SIZE, OR COLOR.
OWNER OF U.S. REG. NOS. 781,824, 3,635,238 AND OTHERS.
NO CLAIM IS MADE TO THE EXCLUSIVE RIGHT TO USE "CHEWY", APART FROM THE MARK AS SHOWN.
FOR CANDY (U.S. CL. 46).
CHRISTINE COOPER, EXAMINING ATTORNEY

CLASS 30—(Continued).

SN 85-318,124. AUSJOR FOODS CORPORATION, PEMBROKE PINES, FL. FILED 5-11-2011.

Saucy Ray's

THE MARK CONSISTS OF STANDARD CHARACTERS WITHOUT CLAIM TO ANY PARTICULAR FONT, STYLE, SIZE, OR COLOR.
FOR BARBECUE SAUCE; BARBEQUE SAUCE; CHIMICHURRI SAUCE; SAUCE MIXES; SAUCES; SAUCES FOR BARBECUED MEAT; STEAK SAUCE (U.S. CL. 46).
FIRST USE 1-1-2011; IN COMMERCE 1-1-2011.
JENNIFER DIXON, EXAMINING ATTORNEY

SN 85-318,253. LEWIS BROTHERS BAKERIES, INCORPORATED, DBA LEWIS BAKERIES, INC., EVANSVILLE, IN. FILED 5-11-2011.

TRIM O'S

THE MARK CONSISTS OF STANDARD CHARACTERS WITHOUT CLAIM TO ANY PARTICULAR FONT, STYLE, SIZE, OR COLOR.
FOR BAKERY PRODUCTS (U.S. CL. 46).
WILLIAM ROSSMAN, EXAMINING ATTORNEY

SN 85-324,861. ANDRE PROST, INC., OLD SAYBROOK, CT. FILED 5-19-2011.

HONEES

THE MARK CONSISTS OF STANDARD CHARACTERS WITHOUT CLAIM TO ANY PARTICULAR FONT, STYLE, SIZE, OR COLOR.
OWNER OF U.S. REG. NO. 1,696,339.
FOR CANDY (U.S. CL. 46).
FIRST USE 10-9-1964; IN COMMERCE 10-9-1964.
EMILY CARLSEN, EXAMINING ATTORNEY

CLASS 30—(Continued).

SN 85-342,321. CLAFFEY, DANIEL F., STEVENSON RANCH, CA. FILED 6-9-2011.

MAJOR LEAGUE COFFEE

THE MARK CONSISTS OF STANDARD CHARACTERS WITHOUT CLAIM TO ANY PARTICULAR FONT, STYLE, SIZE, OR COLOR.

NO CLAIM IS MADE TO THE EXCLUSIVE RIGHT TO USE "COFFEE", APART FROM THE MARK AS SHOWN, FOR COFFEE; COFFEE BEANS; ALL OF THE FOREGOING NOT RELATING TO BASEBALL OR SOFTBALL OR A BASEBALL OR SOFTBALL TEAM (U.S. CL. 46).
KAPIL BHANOT, EXAMINING ATTORNEY

SN 85-344,655. BARILLA G. E R. FRATELLI - SOCIETÀ PER AZIONI, PARMA, ITALY, FILED 6-13-2011.

SPAGHETTATA

THE MARK CONSISTS OF STANDARD CHARACTERS WITHOUT CLAIM TO ANY PARTICULAR FONT, STYLE, SIZE, OR COLOR.

FOR PASTA, SAUCE, SALAD DRESSINGS, FOOD SEASONINGS, SEASONING MIXES, SEASONINGS, PREPARED AND/OR PACKAGED FOODS, DISHES, AND MEALS, CONSISTING PRIMARILY OF RICE, BREAD, CEREALS, NOODLES, READY-MADE SAUCES AND/OR PASTRIES (U.S. CL. 46).
AISHA CLARKE, EXAMINING ATTORNEY

SN 85-345,230. HO-CHUNK NATION, BLACK RIVER FALLS, WI. FILED 6-14-2011.

DA-XU

THE MARK CONSISTS OF STANDARD CHARACTERS WITHOUT CLAIM TO ANY PARTICULAR FONT, STYLE, SIZE, OR COLOR.

FOR COFFEE (U.S. CL. 46).
FIRST USE 8-0-2010; IN COMMERCE 8-0-2010.
KATHLEEN M. VANSTON, EXAMINING ATTORNEY

CLASS 31—NATURAL AGRICULTURAL PRODUCTS

SN 76-703,814. EYES WIDE OPEN (EWO) CORPORATION, ENCINO, CA. FILED 7-16-2010.

MY BFF

THE MARK CONSISTS OF STANDARD CHARACTERS WITHOUT CLAIM TO ANY PARTICULAR FONT, STYLE, SIZE, OR COLOR.

OWNER OF U.S. REG. NO. 3,936,135.
FOR LIVE FISH, AQUARIUM FISH; SOIL INFUSED WITH FISH EGGS FOR SUBSEQUENT HYDRATION AND EGG HATCHING (U.S. CLS. 1 AND 46).
FIRST USE 5-0-2010; IN COMMERCE 5-0-2010.
ALYSSA STEEL, EXAMINING ATTORNEY

SN 77-553,978. MASTRONARDI PRODUCE LTD., SANTA BARBARA, CA. FILED 8-22-2008.

POM POM TOMS

THE MARK CONSISTS OF STANDARD CHARACTERS WITHOUT CLAIM TO ANY PARTICULAR FONT, STYLE, SIZE, OR COLOR.

PRIORITY CLAIMED UNDER SEC. 44(D) ON CANADA APPLICATION NO. 1406073, FILED 8-5-2008, REG. NO. TMA801632, DATED 7-6-2011, EXPIRES 7-6-2026.

FOR FRESH VEGETABLES; FRESH TOMATOES; RAW TOMATOES; UNPROCESSED TOMATOES (U.S. CLS. 1 AND 46).
FIRST USE 5-16-2009; IN COMMERCE 5-16-2009.
CHRISTINA SOBRAL, EXAMINING ATTORNEY

SN 85-105,577. WHOLESUM FAMILY FARMS, INC., NO-GALES, AZ. FILED 8-11-2010.



NO CLAIM IS MADE TO THE EXCLUSIVE RIGHT TO USE "WHOLESOME", APART FROM THE MARK AS SHOWN.

THE MARK CONSISTS OF THREE LEAVES APPEARING ABOVE THE STYLIZED WORDS "WHOLESUM HARVEST"; THE WORDING IS CONTAINED WITHIN A SHADED RECTANGLE.

FOR FRESH FRUITS AND FRESH VEGETABLES (U.S. CLS. 1 AND 46).
FIRST USE 10-1-2010; IN COMMERCE 10-1-2010.
MICHAEL LITZAU, EXAMINING ATTORNEY

CLASS 31—(Continued).

SN 85-128,825. MOÑO AZUL S.A., GUERRICO, RIO NEGRO, ARGENTINA, FILED 9-14-2010.



THE COLOR(S) BLUE IS/ARE CLAIMED AS A FEATURE OF THE MARK.

THE MARK CONSISTS OF A BLUE BOW ABOVE THE WORDS "MOÑO AZUL" IN BLUE STYLIZED LETTERS.

THE ENGLISH TRANSLATION OF "MONO AZUL" IN THE MARK IS "BLUE BOW OR BLUE BUN (HAIRSTYLE)".

FOR FRESH FRUIT (U.S. CLS. 1 AND 46).

FIRST USE 6-30-1961; IN COMMERCE 1-20-1999.

JESSICA A. POWERS, EXAMINING ATTORNEY

SN 85-140,890. KELLY FOODS CORPORATION, BERLIN, MD. FILED 9-29-2010.

NOGGIN NUGGETS

THE MARK CONSISTS OF STANDARD CHARACTERS WITHOUT CLAIM TO ANY PARTICULAR FONT, STYLE, SIZE, OR COLOR.

NO CLAIM IS MADE TO THE EXCLUSIVE RIGHT TO USE "NUGGETS", APART FROM THE MARK AS SHOWN.

FOR PET FOOD; PET TREATS (U.S. CLS. 1 AND 46).

BRENDAN MCCAULEY, EXAMINING ATTORNEY

SN 85-144,911. KELLY FOODS CORPORATION, BERLIN, MD. FILED 10-5-2010.

BRILLIANCE BITES

THE MARK CONSISTS OF STANDARD CHARACTERS WITHOUT CLAIM TO ANY PARTICULAR FONT, STYLE, SIZE, OR COLOR.

NO CLAIM IS MADE TO THE EXCLUSIVE RIGHT TO USE "BITES", APART FROM THE MARK AS SHOWN.

FOR PET FOOD; PET TREATS (U.S. CLS. 1 AND 46).

BRENDAN MCCAULEY, EXAMINING ATTORNEY

CLASS 31—(Continued).

SN 85-151,187. TIANJIN DONGJIANG FOOD CO., LTD., TIANJIN CITY, CHINA, FILED 10-13-2010.



THE MARK CONSISTS OF A VERTICAL FISH SHAPE CONTAINING A DESIGN COMPOSED OF HOLLOW STROKES, FIVE CIRCULAR DOTS ABOVE THE FISH SHAPE, AND TWO CHINESE CHARACTERS UNDER THE FISH SHAPE.

THE NON-LATIN CHARACTERS IN THE MARK TRANSLITERATE TO JIE; LONG AND THIS MEANS "CLEAN"; "PROSPEROUS" IN ENGLISH. THE SYMBOL IN THE FISH SHAPE HAS NO MEANING IN A FOREIGN LANGUAGE.

FOR ANIMAL FEED; ANIMAL FOODSTUFFS; BIRD FOOD; FISH MEAL FOR ANIMAL CONSUMPTION; FODDER; FOOD FOR ANIMALS; LIVE BAITS; LIVE FISHING BAIT; PET FOOD; PROTEIN FOR ANIMAL CONSUMPTION (U.S. CLS. 1 AND 46).

FIRST USE 7-23-2010; IN COMMERCE 7-23-2010.

APRIL ROACH, EXAMINING ATTORNEY

SN 85-185,265. MARENGO FOODS COMPANY, LLC, DALLAS, TX. FILED 11-25-2010.



FOR FRESH FRUIT AND VEGETABLES (U.S. CLS. 1 AND 46).

FIRST USE 10-1-2009; IN COMMERCE 12-1-2009.

JOHN KELLY, EXAMINING ATTORNEY

CLASS 31—(Continued).

SN 85-196,684. PREVAR LIMITED, HASTINGS, NEW ZEALAND, FILED 12-13-2010.



PRIORITY CLAIMED UNDER SEC. 44(D) ON NEW ZEALAND APPLICATION NO. 829377, FILED 8-24-2010, REG. NO. 829377, DATED 8-24-2010, EXPIRES 8-24-2020.

THE MARK CONSISTS OF THE LETTERS "S", "M" AND "I" IN LOWER-CASE BLOCK LETTERING, FOLLOWED BY THE LETTERS "T" AND "X", IN LOWER-CASE LETTERING, TILTED TO THE LEFT, FOLLOWED BY THE LETTERS "E" AND "N", IN LOWER-CASE BLOCK LETTERING. FOR FRESH FRUITS (U.S. CLS. 1 AND 46). ALLISON HOLTZ, EXAMINING ATTORNEY

SN 85-197,307. FRUIT TRADE, LLC, CORAL GABLES, FL. FILED 12-14-2010.

KING BANANA

NO CLAIM IS MADE TO THE EXCLUSIVE RIGHT TO USE "BANANA", APART FROM THE MARK AS SHOWN.

THE COLOR(S) YELLOW AND BLUE IS/ARE CLAIMED AS A FEATURE OF THE MARK.

THE MARK CONSISTS OF YELLOW BANANAS WITH A BLUE CROWN ON TOP OF THE BANANA STEM AND THE WORDS "KING BANANA" ALSO ON TOP OF THE FINGERS; THE CROWN HAS YELLOW DOTS THROUGHOUT.

FOR FRESH BANANAS (U.S. CLS. 1 AND 46). FIRST USE 1-15-2009; IN COMMERCE 1-15-2009. DAVID I, EXAMINING ATTORNEY

CLASS 31—(Continued).

SN 85-210,189. GOLDEN LIGHT, LLC, CORAL GABLES, FL. FILED 1-4-2011.



OWNER OF U.S. REG. NO. 3,294,457.

THE MARK CONSISTS OF THE WORD "PUPPITOS" IN STYLIZED TEXT IN A RISING DIAGONAL DIRECTION AND THE ILLUSTRATION OF A DOG IMMEDIATELY ABOVE THE WORD.

FOR PET FOOD; PET TREATS (U.S. CLS. 1 AND 46). SUZANNE BLANE, EXAMINING ATTORNEY

SN 85-210,224. GOLDEN LIGHT, LLC, CORAL GABLES, FL. FILED 1-4-2011.

PUPPITOS

THE MARK CONSISTS OF STANDARD CHARACTERS WITHOUT CLAIM TO ANY PARTICULAR FONT, STYLE, SIZE, OR COLOR.

OWNER OF U.S. REG. NO. 3,294,457.

FOR PET FOOD; PET TREATS (U.S. CLS. 1 AND 46). SUZANNE BLANE, EXAMINING ATTORNEY

SN 85-226,552. NICK-EM BUILDERS, LLC, DBA FOPPERS GOURMET PET TREAT BAKERY, LOGANSPORT, IN. FILED 1-26-2011.

Foppers

THE MARK CONSISTS OF STANDARD CHARACTERS WITHOUT CLAIM TO ANY PARTICULAR FONT, STYLE, SIZE, OR COLOR.

FOR DOG BISCUITS; DOG FOOD; DOG TREATS; EDIBLE CHEWS FOR DOGS; PET TREATS (U.S. CLS. 1 AND 46).

FIRST USE 3-1-2004; IN COMMERCE 3-1-2004.

JEFFREY LOOK, EXAMINING ATTORNEY

CLASS 31—(Continued).

SN 85-263,162. PRECISION PET PRODUCTS, INC., COSTA MESA, CA. FILED 3-10-2011.

THE REVOLUTION HAS BEGUN

THE MARK CONSISTS OF STANDARD CHARACTERS WITHOUT CLAIM TO ANY PARTICULAR FONT, STYLE, SIZE, OR COLOR.
FOR CONSUMABLE CHEW TOY FOR PETS (U.S. CLS. 1 AND 46).
APRIL ROACH, EXAMINING ATTORNEY

SN 85-269,461. PENINSULA CHEMICAL, LLC, GEORGETOWN, DE. FILED 3-17-2011.

BUCK IN A BOX FOOD PLOT

THE MARK CONSISTS OF STANDARD CHARACTERS WITHOUT CLAIM TO ANY PARTICULAR FONT, STYLE, SIZE, OR COLOR.
NO CLAIM IS MADE TO THE EXCLUSIVE RIGHT TO USE "FOOD PLOT", APART FROM THE MARK AS SHOWN.
FOR WILDLIFE SEED MIXTURES (U.S. CLS. 1 AND 46).
SEAN CROWLEY, EXAMINING ATTORNEY

SN 85-269,525. CALIFORNIA ARTICHOKE AND VEGETABLE GROWERS CORPORATION, DBA OCEAN MIST FARMS, CASTROVILLE, CA. FILED 3-17-2011.

CASTROVILLE GREEN GLOBE

THE MARK CONSISTS OF STANDARD CHARACTERS WITHOUT CLAIM TO ANY PARTICULAR FONT, STYLE, SIZE, OR COLOR.
OWNER OF U.S. REG. NO. 2,937,078.
NO CLAIM IS MADE TO THE EXCLUSIVE RIGHT TO USE "GREEN GLOBE", APART FROM THE MARK AS SHOWN.
SEC. 2(F).
FOR FRESH ARTICHOKE; FRESH VEGETABLES (U.S. CLS. 1 AND 46).
FIRST USE 8-1-1994; IN COMMERCE 8-1-1994.
JUDITH HELFMAN, EXAMINING ATTORNEY

CLASS 31—(Continued).

SN 85-274,431. NOOTIE LLC, DELRAY BEACH, FL. FILED 3-23-2011.

YUMZIES YUMMY TASTE! ZERO GRAINS!

THE MARK CONSISTS OF STANDARD CHARACTERS WITHOUT CLAIM TO ANY PARTICULAR FONT, STYLE, SIZE, OR COLOR.
NO CLAIM IS MADE TO THE EXCLUSIVE RIGHT TO USE "YUMMY TASTE! ZERO GRAINS!", APART FROM THE MARK AS SHOWN.
FOR CONSUMABLE PET CHEWS; PET TREATS (U.S. CLS. 1 AND 46).
GEOFFREY FOSDICK, EXAMINING ATTORNEY

SN 85-274,550. KELLY FOODS CORPORATION, BERLIN, MD. FILED 3-23-2011.

CAT TREATS PLUS

THE MARK CONSISTS OF STANDARD CHARACTERS WITHOUT CLAIM TO ANY PARTICULAR FONT, STYLE, SIZE, OR COLOR.
NO CLAIM IS MADE TO THE EXCLUSIVE RIGHT TO USE "CAT TREATS", APART FROM THE MARK AS SHOWN.
FOR PET TREATS (U.S. CLS. 1 AND 46).
MORGAN WYNNE, EXAMINING ATTORNEY

SN 85-274,566. KELLY FOODS CORPORATION, BERLIN, MD. FILED 3-23-2011.

CAT FOOD PLUS

THE MARK CONSISTS OF STANDARD CHARACTERS WITHOUT CLAIM TO ANY PARTICULAR FONT, STYLE, SIZE, OR COLOR.
NO CLAIM IS MADE TO THE EXCLUSIVE RIGHT TO USE "CAT FOOD", APART FROM THE MARK AS SHOWN.
FOR PET FOOD (U.S. CLS. 1 AND 46).
MORGAN WYNNE, EXAMINING ATTORNEY

CLASS 31—(Continued).

SN 85-274,595. KELLY FOODS CORPORATION, BERLIN, MD. FILED 3-23-2011.

FRUIT FIT

THE MARK CONSISTS OF STANDARD CHARACTERS WITHOUT CLAIM TO ANY PARTICULAR FONT, STYLE, SIZE, OR COLOR.

NO CLAIM IS MADE TO THE EXCLUSIVE RIGHT TO USE "FRUIT", APART FROM THE MARK AS SHOWN.

FOR PET FOOD AND PET TREATS (U.S. CLS. 1 AND 46).

MORGAN WYNNE, EXAMINING ATTORNEY

CLASS 31—(Continued).

SN 85-276,884. PUGZEE'S FARM, LLC, LENOX, MA. FILED 3-25-2011.

PUGZEE'S FARM

THE MARK CONSISTS OF STANDARD CHARACTERS WITHOUT CLAIM TO ANY PARTICULAR FONT, STYLE, SIZE, OR COLOR.

NO CLAIM IS MADE TO THE EXCLUSIVE RIGHT TO USE "FARM", APART FROM THE MARK AS SHOWN.

FOR FRESH FRUIT AND VEGETABLES; LIVE CHRISTMAS TREES (U.S. CLS. 1 AND 46).

GEOFFREY FOSDICK, EXAMINING ATTORNEY

SN 85-274,612. KELLY FOODS CORPORATION, BERLIN, MD. FILED 3-23-2011.

RAW PERFECTION

THE MARK CONSISTS OF STANDARD CHARACTERS WITHOUT CLAIM TO ANY PARTICULAR FONT, STYLE, SIZE, OR COLOR.

NO CLAIM IS MADE TO THE EXCLUSIVE RIGHT TO USE "RAW", APART FROM THE MARK AS SHOWN.

FOR PET FOOD AND PET TREATS (U.S. CLS. 1 AND 46).

MORGAN WYNNE, EXAMINING ATTORNEY

SN 85-277,199. PENNFIELD CORPORATION, LANCASTER, PA. FILED 3-25-2011.

EnduroEvent Ener-G

THE MARK CONSISTS OF STANDARD CHARACTERS WITHOUT CLAIM TO ANY PARTICULAR FONT, STYLE, SIZE, OR COLOR.

NO CLAIM IS MADE TO THE EXCLUSIVE RIGHT TO USE "ENERGY", APART FROM THE MARK AS SHOWN.

FOR ANIMAL FEED (U.S. CLS. 1 AND 46).

TRACY WHITTAKER-BROWN, EXAMINING ATTORNEY

SN 85-275,293. HOWDEN FARM, LLC, SHEFFIELD, MA. FILED 3-24-2011.

HOWDEN FARM

THE MARK CONSISTS OF STANDARD CHARACTERS WITHOUT CLAIM TO ANY PARTICULAR FONT, STYLE, SIZE, OR COLOR.

NO CLAIM IS MADE TO THE EXCLUSIVE RIGHT TO USE "FARM", APART FROM THE MARK AS SHOWN.

FOR FRESH FRUIT AND VEGETABLES; PLANT SEEDS (U.S. CLS. 1 AND 46).

KELLEY WELLS, EXAMINING ATTORNEY

SN 85-277,210. PENNFIELD CORPORATION, LANCASTER, PA. FILED 3-25-2011.

Grand Prix Granola

THE MARK CONSISTS OF STANDARD CHARACTERS WITHOUT CLAIM TO ANY PARTICULAR FONT, STYLE, SIZE, OR COLOR.

NO CLAIM IS MADE TO THE EXCLUSIVE RIGHT TO USE "GRANOLA", APART FROM THE MARK AS SHOWN.

FOR ANIMAL FEED (U.S. CLS. 1 AND 46).

TRACY WHITTAKER-BROWN, EXAMINING ATTORNEY

CLASS 31—(Continued).

SN 85-277,233. PENNFIELD CORPORATION, LANCASTER, PA. FILED 3-25-2011.

Fibregized Omega

THE MARK CONSISTS OF STANDARD CHARACTERS WITHOUT CLAIM TO ANY PARTICULAR FONT, STYLE, SIZE, OR COLOR.

NO CLAIM IS MADE TO THE EXCLUSIVE RIGHT TO USE "OMEGA", APART FROM THE MARK AS SHOWN.

FOR ANIMAL FEED (U.S. CLS. 1 AND 46).
TRACY WHITTAKER-BROWN, EXAMINING ATTORNEY

CLASS 31—(Continued).

SN 85-277,271. PENNFIELD CORPORATION, LANCASTER, PA. FILED 3-25-2011.

Equinox Sales Prep

THE MARK CONSISTS OF STANDARD CHARACTERS WITHOUT CLAIM TO ANY PARTICULAR FONT, STYLE, SIZE, OR COLOR.

NO CLAIM IS MADE TO THE EXCLUSIVE RIGHT TO USE "SALES PREP", APART FROM THE MARK AS SHOWN.

FOR ANIMAL FEED (U.S. CLS. 1 AND 46).
TRACY WHITTAKER-BROWN, EXAMINING ATTORNEY

SN 85-277,241. PENNFIELD CORPORATION, LANCASTER, PA. FILED 3-25-2011.

Senior Energized Choice

THE MARK CONSISTS OF STANDARD CHARACTERS WITHOUT CLAIM TO ANY PARTICULAR FONT, STYLE, SIZE, OR COLOR.

NO CLAIM IS MADE TO THE EXCLUSIVE RIGHT TO USE "SENIOR", APART FROM THE MARK AS SHOWN.

FOR ANIMAL FEED (U.S. CLS. 1 AND 46).
TRACY WHITTAKER-BROWN, EXAMINING ATTORNEY

SN 85-277,416. GRATEFUL PET, INC., VERO BEACH, FL. FILED 3-25-2011.

Grateful Pet

THE MARK CONSISTS OF STANDARD CHARACTERS WITHOUT CLAIM TO ANY PARTICULAR FONT, STYLE, SIZE, OR COLOR.

NO CLAIM IS MADE TO THE EXCLUSIVE RIGHT TO USE "PET", APART FROM THE MARK AS SHOWN.

FOR PET FOOD; PET TREATS (U.S. CLS. 1 AND 46).
FIRST USE 4-16-2010; IN COMMERCE 7-6-2010.
ANDREA HACK, EXAMINING ATTORNEY

SN 85-277,262. PENNFIELD CORPORATION, LANCASTER, PA. FILED 3-25-2011.

Cool 'n' Lite

THE MARK CONSISTS OF STANDARD CHARACTERS WITHOUT CLAIM TO ANY PARTICULAR FONT, STYLE, SIZE, OR COLOR.

NO CLAIM IS MADE TO THE EXCLUSIVE RIGHT TO USE "LITE", APART FROM THE MARK AS SHOWN.

FOR ANIMAL FEED (U.S. CLS. 1 AND 46).
TRACY WHITTAKER-BROWN, EXAMINING ATTORNEY

SN 85-278,001. FRESHFETCH PET FOODS, INC., AKA FRESHFETCH, PALM SPRINGS, CA. FILED 3-27-2011.

freshfetch

THE MARK CONSISTS OF STANDARD CHARACTERS WITHOUT CLAIM TO ANY PARTICULAR FONT, STYLE, SIZE, OR COLOR.

FOR PET FOOD (U.S. CLS. 1 AND 46).
FIRST USE 1-28-2008; IN COMMERCE 1-28-2008.
H. M. FISHER, EXAMINING ATTORNEY

CLASS 31—(Continued).

SN 85-279,623. J. FRANK SCHMIDT & SON CO., BORING,
OR. FILED 3-29-2011.

HEARTLAND

THE MARK CONSISTS OF STANDARD CHARACTERS
WITHOUT CLAIM TO ANY PARTICULAR FONT, STYLE,
SIZE, OR COLOR.

FOR LIVING TREES (U.S. CLS. 1 AND 46).
FIRST USE 2-19-2011; IN COMMERCE 2-19-2011.
GILBERT SWIFT, EXAMINING ATTORNEY

SN 85-279,668. J. FRANK SCHMIDT & SON CO., BORING,
OR. FILED 3-29-2011.

COBBLESTONE

THE MARK CONSISTS OF STANDARD CHARACTERS
WITHOUT CLAIM TO ANY PARTICULAR FONT, STYLE,
SIZE, OR COLOR.

FOR LIVING TREES (U.S. CLS. 1 AND 46).
FIRST USE 2-19-2011; IN COMMERCE 2-19-2011.
GILBERT SWIFT, EXAMINING ATTORNEY

SN 85-290,966. EXPORTALIZAS MEXICANAS SA DE CV,
CULIACÁN SINALOA, MEXICO, FILED 4-9-2011.

THUNDER

THE MARK CONSISTS OF STANDARD CHARACTERS
WITHOUT CLAIM TO ANY PARTICULAR FONT, STYLE,
SIZE, OR COLOR.

FOR FRESH FRUITS AND VEGETABLES (U.S. CLS. 1
AND 46).
KELLY TRUSILO, EXAMINING ATTORNEY

CLASS 31—(Continued).

SN 85-291,515. J. FRANK SCHMIDT & SON CO., BORING,
OR. FILED 4-11-2011.

BEACON

THE MARK CONSISTS OF STANDARD CHARACTERS
WITHOUT CLAIM TO ANY PARTICULAR FONT, STYLE,
SIZE, OR COLOR.

FOR LIVING ORNAMENTAL TREES (U.S. CLS. 1 AND
46).
GILBERT SWIFT, EXAMINING ATTORNEY

SN 85-292,477. 1-800-FLOWERS.COM, INC., CARLE PLACE,
NY. FILED 4-12-2011.

A-DOG-ABLE

THE MARK CONSISTS OF STANDARD CHARACTERS
WITHOUT CLAIM TO ANY PARTICULAR FONT, STYLE,
SIZE, OR COLOR.

FOR (BASED ON USE) LIVE FLOWER ARRANGE-
MENTS; (BASED ON INTENT-TO-USE) LIVE PLANTS
(U.S. CLS. 1 AND 46).
FIRST USE 9-27-2010; IN COMMERCE 9-27-2010.
CHRISTINE MARTIN, EXAMINING ATTORNEY

SN 85-293,019. PUGZEE'S FARM, LLC, LENOX, MA. FILED
4-12-2011.



NO CLAIM IS MADE TO THE EXCLUSIVE RIGHT TO
USE "FARM" AND "WASHINGTON, MASSACHUSETTS",
APART FROM THE MARK AS SHOWN.

THE MARK CONSISTS OF AN OVAL SHAPE WITH THE
PHRASE "VETERANS HARVESTING HOPE" ABOVE IT
AND THE PHRASE "WASHINGTON, MASSACHUSETTS"
BELOW IT. THESE PHRASES ARE BOTH FLANKED BY
TWO DOTS. THE WORD "PUGZEE'S" IS WITHIN THE
OVAL AT THE TOP AND THE WORD "FARM" IS ON THE
BOTTOM WITHIN THE OVAL. BETWEEN "PUGZEE'S"
AND "FARM" IS A DRAWING OF A PUG STANDING IN
THE MIDDLE WITH A DRAWING OF TWO APPLES TO ITS
LEFT AND A DRAWING OF A HONEYDIPPER TO ITS
RIGHT.

FOR FRESH FRUIT AND VEGETABLES; LIVE
CHRISTMAS TREES (U.S. CLS. 1 AND 46).
GEOFFREY FOSDICK, EXAMINING ATTORNEY

CLASS 31—(Continued).

SN 85-293,070. MICROBASICS, SAN DIEGO, CA. FILED 4-12-2011.

Surveillance

THE MARK CONSISTS OF STANDARD CHARACTERS WITHOUT CLAIM TO ANY PARTICULAR FONT, STYLE, SIZE, OR COLOR.

FOR ADDITIVES TO ANIMAL FEED, NOT FOR MEDICAL PURPOSES; NON-MEDICATED ADDITIVES FOR ANIMAL FEED; NUTRITIONAL ADDITIVES FOR ANIMAL FOODSTUFFS, NOT FOR MEDICAL PURPOSES (U.S. CLS. 1 AND 46).

FIRST USE 4-5-2010; IN COMMERCE 4-5-2010.
GRETTA YAO, EXAMINING ATTORNEY

SN 85-293,229. NEWSHAM CHOICE GENETICS, LLC, WEST DES MOINES, IA. FILED 4-12-2011.

MAP YOUR SUCCESS

OWNER OF U.S. REG. NO. 3,667,936.

THE MARK CONSISTS OF THE WORDING "MAP YOUR SUCCESS" WHERE THE "O" IN "YOUR" IS REPRESENTED BY A COMPASS LIKE DESIGN.

FOR LIVE ANIMALS, NAMELY, SWINE FOR BREEDING PURPOSES (U.S. CLS. 1 AND 46).

FIRST USE 11-30-2007; IN COMMERCE 11-30-2007.
REBECCA SMITH, EXAMINING ATTORNEY

SN 85-293,338. PUGZEE'S FARM, LLC, LENOX, MA. FILED 4-12-2011.



NO CLAIM IS MADE TO THE EXCLUSIVE RIGHT TO USE "FARM" AND "WASHINGTON, MASSACHUSETTS", APART FROM THE MARK AS SHOWN.

THE COLOR(S) GREEN, RED, WHITE, GREY, BEIGE AND BROWN IS/ARE CLAIMED AS A FEATURE OF THE MARK.

THE MARK CONSISTS OF A GREEN OVAL SHAPE WITH THE PHRASE "VETERANS HARVESTING HOPE" ABOVE IT AND THE PHRASE "WASHINGTON, MASSACHUSETTS"

CLASS 31—(Continued).

BELOW IT, BOTH IN GREEN LETTERING. THESE PHRASES ARE BOTH FLANKED BY TWO GREEN DOTS. THE WORD "PUGZEE'S" IN WHITE IS WITHIN THE OVAL AT THE TOP AND THE WORD "FARM" IN WHITE IS WITHIN THE OVAL ON THE BOTTOM. BETWEEN "PUGZEE'S" AND "FARM" IS A DRAWING OF A GREY PUG STANDING IN THE MIDDLE WITH A DRAWING OF TWO RED APPLES WITH GREEN LEAVES AND GREY STEM TO ITS LEFT AND A DRAWING OF A BEIGE AND BROWN HONEYPOT AND A BEIGE DIPPER TO ITS RIGHT.

FOR FRESH FRUIT AND VEGETABLES; LIVE CHRISTMAS TREES (U.S. CLS. 1 AND 46).
GEOFFREY FOSDICK, EXAMINING ATTORNEY

SN 85-294,296. MID-WEST FEED & BEDDING LLC, LA-CYGNE, KS. FILED 4-13-2011.

GEN-X

THE MARK CONSISTS OF STANDARD CHARACTERS WITHOUT CLAIM TO ANY PARTICULAR FONT, STYLE, SIZE, OR COLOR.

FOR ANIMAL FEED (U.S. CLS. 1 AND 46).
FIRST USE 9-30-2010; IN COMMERCE 9-30-2010.
THOMAS MANOR, EXAMINING ATTORNEY

SN 85-294,343. PET KING CORPORATION, INDUSTRY, CA. FILED 4-13-2011.



THE MARK CONSISTS OF THE LITERAL ELEMENT P WHEREIN THERE IS AN IMAGE OF PUPPY HOLDING BONE IN HIS MOUTH INSIDE LETTER P AS SHOWN IN THE MARK.

FOR PET FOOD; CONSUMABLE PET CHEWS (U.S. CLS. 1 AND 46).
GEORGE LORENZO, EXAMINING ATTORNEY

CLASS 31—(Continued).

SN 85-294,359. MICROBASICS, SAN DIEGO, CA. FILED 4-13-2011.

AquaMune

THE MARK CONSISTS OF STANDARD CHARACTERS WITHOUT CLAIM TO ANY PARTICULAR FONT, STYLE, SIZE, OR COLOR.

FOR AQUACULTURE FEED (U.S. CLS. 1 AND 46).
FIRST USE 6-5-2007; IN COMMERCE 6-5-2007.
GRETTA YAO, EXAMINING ATTORNEY

CLASS 31—(Continued).

SN 85-308,726. GREEN FUSE BOTANICALS, INC., SANTA MONICA, CA. FILED 4-29-2011.

GOOD AND PLENTY

THE MARK CONSISTS OF STANDARD CHARACTERS WITHOUT CLAIM TO ANY PARTICULAR FONT, STYLE, SIZE, OR COLOR.

FOR LIVE PLANTS, NAMELY, PETUNIA (U.S. CLS. 1 AND 46).
FIRST USE 12-1-2010; IN COMMERCE 12-1-2010.
JOHN DWYER, EXAMINING ATTORNEY

SN 85-296,685. TARAMIKO, INC., LOS ANGELES, CA. FILED 4-15-2011.

happy hemp

THE MARK CONSISTS OF STANDARD CHARACTERS WITHOUT CLAIM TO ANY PARTICULAR FONT, STYLE, SIZE, OR COLOR.

NO CLAIM IS MADE TO THE EXCLUSIVE RIGHT TO USE "HEMP", APART FROM THE MARK AS SHOWN.
FOR HEMP SEEDS (U.S. CLS. 1 AND 46).
FIRST USE 4-0-2011; IN COMMERCE 4-0-2011.
CHRISTINA SOBRAL, EXAMINING ATTORNEY

SN 85-320,869. CAMPO VERDE TUCAN S.A. DE C.V., MONTERREY, MEXICO, FILED 5-13-2011.



THE COLOR(S) BLUE AND GREEN IS/ARE CLAIMED AS A FEATURE OF THE MARK.

THE MARK CONSISTS OF THE TERMS "GREEN FIELD" IN BLUE STYLIZED FONT OUTLINED IN GREEN AND "BY GREEN TUCAN" IN BLUE STYLIZED FONT, WITH A FANCIFUL TOUCAN PROFILE DESIGN AND A FANCIFUL MOUNTAIN DESIGN IN GREEN.

FOR FRESH FRUIT AND VEGETABLES (U.S. CLS. 1 AND 46).
JESSICA A. POWERS, EXAMINING ATTORNEY

SN 85-308,298. GREEN FUSE BOTANICALS, INC., SANTA MONICA, CA. FILED 4-29-2011.

SHADOW KING

THE MARK CONSISTS OF STANDARD CHARACTERS WITHOUT CLAIM TO ANY PARTICULAR FONT, STYLE, SIZE, OR COLOR.

FOR LIVE PLANTS, NAMELY, REX BEGONIA (U.S. CLS. 1 AND 46).
FIRST USE 9-1-2010; IN COMMERCE 9-1-2010.
JOHN DWYER, EXAMINING ATTORNEY

SN 85-333,125. FESTFARE, INC, LAS VEGAS, NV. FILED 5-28-2011.

Doghouse Bouquet

THE MARK CONSISTS OF STANDARD CHARACTERS WITHOUT CLAIM TO ANY PARTICULAR FONT, STYLE, SIZE, OR COLOR.

NO CLAIM IS MADE TO THE EXCLUSIVE RIGHT TO USE "BOUQUET", APART FROM THE MARK AS SHOWN.
FOR CUT FLOWERS; LIVE FLOWER ARRANGEMENTS; LIVE FLOWERS; NATURAL PLANTS AND FLOWERS (U.S. CLS. 1 AND 46).

FIRST USE 5-28-2011; IN COMMERCE 5-28-2011.
EMILY CHUO, EXAMINING ATTORNEY

CLASS 31—(Continued).

SN 85-350,754. SYNGENTA PARTICIPATIONS AG, BASEL, SWITZERLAND, FILED 6-20-2011.



OWNER OF U.S. REG. NOS. 802,033 AND 1,486,371.
THE MARK CONSISTS OF THE LETTERS "NK" WITHIN AN OVAL WHEREIN THE OVAL IS DIVIDED BY A WAVY LINE.

FOR AGRICULTURAL SEEDS (U.S. CLS. 1 AND 46).
FIRST USE 6-4-1997; IN COMMERCE 6-4-1997.
JOHN HWANG, EXAMINING ATTORNEY

CLASS 32—(Continued).

SN 77-904,743. GT BEVERAGE COMPANY, LLC, LAGUNA NIGUEL, CA. FILED 1-4-2010.



THE MARK CONSISTS OF A THREE-DIMENSIONAL CONFIGURATION OF THE PACKAGING FOR THE GOODS, NAMELY, A BEVERAGE CONTAINER FEATURING A GLOBULAR BOTTLE SHAPE RESEMBLING A COCONUT. THE BROKEN LINES IN THE BOTTOM OF THE BOTTLE AND IN THE NECK AND CAP OF THE BOTTLE ARE NOT CLAIMED AS PART OF THE MARK BUT ARE INSTEAD FOR CONTEXT AND TO SHOW PLACEMENT OF THE MARK ON THE BEVERAGE CONTAINER.

FOR COCONUT JUICE; COCONUT MILK; COCONUT WATER; COCONUT-BASED BEVERAGES; ENERGY DRINKS; FRUIT DRINKS; FRUIT FLAVORED DRINKS; ISOTONIC DRINKS; SPORTS DRINKS (U.S. CLS. 45, 46 AND 48).

REGINA DRUMMOND, EXAMINING ATTORNEY

CLASS 32—LIGHT BEVERAGES

SN 76-706,871. JIL HEALTH PRODUCTS, LLC, BEAUMONT, TX. FILED 3-17-2011.

KICKBACK AND RELAX

THE MARK CONSISTS OF STANDARD CHARACTERS WITHOUT CLAIM TO ANY PARTICULAR FONT, STYLE, SIZE, OR COLOR.

FOR NON-ALCOHOLIC, LIGHTLY CARBONATED BEVERAGES CONTAINING CALMING AGENTS FOR PROMOTING RELAXATION (U.S. CLS. 45, 46 AND 48).
MICHAEL WIENER, EXAMINING ATTORNEY

SN 79-095,070. NEMECO, PARIS, FRANCE, FILED 2-18-2011.

SN 77-259,727. WOLLMAN, RONALD, SILVER SPRING, MD. FILED 8-20-2007.

GIO CAFE

THE MARK CONSISTS OF STANDARD CHARACTERS WITHOUT CLAIM TO ANY PARTICULAR FONT, STYLE, SIZE, OR COLOR.

OWNER OF U.S. REG. NO. 3,881,749.

NO CLAIM IS MADE TO THE EXCLUSIVE RIGHT TO USE "CAFE", APART FROM THE MARK AS SHOWN.

THE NAME IN THE MARK DOES NOT IDENTIFY ANY LIVING INDIVIDUAL.

THE FOREIGN WORDING IN THE MARK "GIO" TRANSLATES TO AN ABBREVIATION OF THE ITALIAN WORD GIOVEDI, WHICH MEANS THURSDAY.

FOR SOFT DRINKS, COFFEE FLAVORED SOFT DRINKS, BOTTLED OR CANNED EXPRESSO FLAVORED BEVERAGES (U.S. CLS. 45, 46 AND 48).

THOMAS MANOR, EXAMINING ATTORNEY

nu

PRIORITY DATE OF 1-7-2011 IS CLAIMED.

OWNER OF INTERNATIONAL REGISTRATION 1070968 DATED 2-18-2011, EXPIRES 2-18-2021.

THE MARK CONSISTS OF THE WORDING "NU" IN A STYLIZED FONT.

FOR BEER; MINERAL AND AERATED WATERS; FRUIT DRINKS AND FRUIT JUICES; SYRUPS AND OTHER PREPARATIONS, NAMELY, SYRUP SUBSTITUTES FOR MAKING BEVERAGES, LEMONADES; FRUIT NECTARS, NON-ALCOHOLIC BEVERAGES, NAMELY, SODA WATER; APERITIFS (U.S. CLS. 45, 46 AND 48).

RENEE MCCRAY, EXAMINING ATTORNEY

CLASS 32—(Continued).

SN 85-014,033. OLD OAK BEER CO., LLC, SAN FRANCISCO, CA. FILED 4-14-2010.

Farm to Bottle

THE MARK CONSISTS OF STANDARD CHARACTERS WITHOUT CLAIM TO ANY PARTICULAR FONT, STYLE, SIZE, OR COLOR.

FOR BEER (U.S. CLS. 45, 46 AND 48).
ANDREA BUTLER, EXAMINING ATTORNEY

SN 85-027,669. CULLIGAN INTERNATIONAL COMPANY, ROSEMONT, IL. FILED 4-30-2010.



OWNER OF U.S. REG. NOS. 1,008,612, 1,588,702 AND OTHERS.

THE COLOR(S) BLUE IS/ARE CLAIMED AS A FEATURE OF THE MARK.

THE MARK CONSISTS OF THE WORDS "CULLIGAN CARES" IN BLUE STYLIZED LETTERING WITH A BLUE STYLIZED HEART THAT REPLACES THE LETTER "S" IN THE WORD "CARES".

FOR BOTTLED WATER (U.S. CLS. 45, 46 AND 48).
FIRST USE 2-1-2010; IN COMMERCE 2-1-2010.
JULIE VEPPUMTHARA, EXAMINING ATTORNEY

SN 85-061,887. EPIC H2O, WILLISTON, VT. FILED 6-14-2010.



NO CLAIM IS MADE TO THE EXCLUSIVE RIGHT TO USE "H2O", APART FROM THE MARK AS SHOWN.

THE MARK CONSISTS OF THE STYLIZED TEXT "EPIC H2O" WITH CURVED LINE AROUND.

FOR POWDERS USED IN THE PREPARATION OF SPORTS HYDRATION DRINKS (U.S. CLS. 45, 46 AND 48).

JACQUELINE A. LAVINE, EXAMINING ATTORNEY

CLASS 32—(Continued).

SN 85-083,442. LA PAZ PRODUCTS, INC., BREA, CA. FILED 7-13-2010.

QUICKWAY SKINNY MARGARITA MIX

THE MARK CONSISTS OF STANDARD CHARACTERS WITHOUT CLAIM TO ANY PARTICULAR FONT, STYLE, SIZE, OR COLOR.

OWNER OF U.S. REG. NOS. 1,184,061, 3,749,538 AND OTHERS.

NO CLAIM IS MADE TO THE EXCLUSIVE RIGHT TO USE "SKINNY MARGARITA MIX", APART FROM THE MARK AS SHOWN.

FOR NON-ALCOHOLIC COCKTAIL MIXES (U.S. CLS. 45, 46 AND 48).

FIRST USE 4-15-2010; IN COMMERCE 4-15-2010.
LOURDES AYALA, EXAMINING ATTORNEY

SN 85-112,304. TARGET BRANDS, INC., MINNEAPOLIS, MN. FILED 8-20-2010.



OWNER OF U.S. REG. NOS. 2,562,603, 2,564,715 AND 3,715,221.

NO CLAIM IS MADE TO THE EXCLUSIVE RIGHT TO USE "VALUE & QUALITY GUARANTEED", APART FROM THE MARK AS SHOWN.

THE MARK CONSISTS OF THE WORDS "VALUE & QUALITY GUARANTEED" INSIDE A CIRCLE POSITIONED TO THE LEFT AND DIVIDED BY A VERTICAL LINE OF THE STACKED WORDS "MARKET PANTRY" ALL WITHIN A ROUNDED HORIZONTAL RECTANGLE.

FOR FLAVORED AND NON-FLAVORED BOTTLED WATERS; SPARKLING WATERS; FRUIT JUICES; VEGETABLE JUICES; FRUIT FLAVORED DRINKS AND JUICES; SELTZER WATER; SMOOTHIES; SOFT DRINKS; FRUIT JUICE CONCENTRATES (U.S. CLS. 45, 46 AND 48).

FIRST USE 11-0-2003; IN COMMERCE 11-0-2003.

ANN E. SAPPENFIELD, EXAMINING ATTORNEY

CLASS 32—(Continued).

SN 85-116,457. INTELLIGENT NUTRIENTS, LLC, MINNEAPOLIS, MN. FILED 8-26-2010.

**INTELLIGENT NUTRIENTS
PLANT STEM CELL SCIENCE**

THE MARK CONSISTS OF STANDARD CHARACTERS WITHOUT CLAIM TO ANY PARTICULAR FONT, STYLE, SIZE, OR COLOR.

OWNER OF U.S. REG. NOS. 3,161,714, 3,867,492 AND OTHERS.

NO CLAIM IS MADE TO THE EXCLUSIVE RIGHT TO USE "NUTRIENTS PLANT STEM CELL SCIENCE", APART FROM THE MARK AS SHOWN.

FOR BEVERAGES, NAMELY, WATER (U.S. CLS. 45, 46 AND 48).

Laurie Kaufman, Examining Attorney

SN 85-127,183. CAROLINA CANNERS, INC., CHERAW, SC. FILED 9-10-2010.

TRUADE

THE MARK CONSISTS OF STANDARD CHARACTERS WITHOUT CLAIM TO ANY PARTICULAR FONT, STYLE, SIZE, OR COLOR.

FOR CONCENTRATES, SYRUPS OR POWDERS USED IN THE PREPARATION OF SOFT DRINKS; SOFT DRINKS (U.S. CLS. 45, 46 AND 48).

FIRST USE 4-18-2011; IN COMMERCE 4-18-2011.

Ernest Shosho, Examining Attorney

SN 85-164,361. CALPIS CO., LTD., TOKYO, JAPAN, FILED 10-29-2010.

CALPIS SODA

THE MARK CONSISTS OF STANDARD CHARACTERS WITHOUT CLAIM TO ANY PARTICULAR FONT, STYLE, SIZE, OR COLOR.

PRIORITY CLAIMED UNDER SEC. 44(D) ON JAPAN APPLICATION NO. 2010-059720, FILED 7-29-2010, REG. NO. 5382293, DATED 1-7-2011, EXPIRES 1-7-2021.

OWNER OF U.S. REG. NOS. 1,014,240, 3,110,530 AND OTHERS.

NO CLAIM IS MADE TO THE EXCLUSIVE RIGHT TO USE "SODA", APART FROM THE MARK AS SHOWN.

FOR NON-ALCOHOLIC BEVERAGES, NAMELY, CARBONATED BEVERAGES; CARBONATED WATERS; FRUIT FLAVORED CARBONATED DRINKS; CARBONATED SOFT DRINKS; SODA WATER (U.S. CLS. 45, 46 AND 48).

Beryl Gardner, Examining Attorney

CLASS 32—(Continued).

SN 85-201,729. WHATABURGER PARTNERSHIP, SAN ANTONIO, TX. FILED 12-20-2010.

THE EXTINGUISHER

THE MARK CONSISTS OF STANDARD CHARACTERS WITHOUT CLAIM TO ANY PARTICULAR FONT, STYLE, SIZE, OR COLOR.

OWNER OF U.S. REG. NO. 2,360,396.

FOR NON-ALCOHOLIC DRINKS SOLD FOR CONSUMPTION ON OR OFF THE PREMISES, NAMELY, FRUIT JUICES, FRUIT DRINKS, FRUIT FLAVORED DRINKS, SPORTS DRINKS, DRINKING WATER, FLAVORED WATER, LEMONADE, FROZEN AND NON-FROZEN CARBONATED BEVERAGES, FROZEN FRUIT BEVERAGES, FRUIT PUNCH (U.S. CLS. 45, 46 AND 48).

Ingrid C. Eulin, Examining Attorney

SN 85-245,921. JOHN J. BALBONI, BEDFORD, NY. FILED 2-18-2011.

**NATURE'S PURE THE ORIGINAL
ORGANIC COLA**

THE MARK CONSISTS OF STANDARD CHARACTERS WITHOUT CLAIM TO ANY PARTICULAR FONT, STYLE, SIZE, OR COLOR.

NO CLAIM IS MADE TO THE EXCLUSIVE RIGHT TO USE "PURE THE ORIGINAL ORGANIC COLA", APART FROM THE MARK AS SHOWN.

FOR FRUIT DRINKS AND FRUIT JUICES MADE IN WHOLE OR SUBSTANTIAL PART OF ORGANIC MATERIALS; SOFT DRINKS, NAMELY, CARBONATED AND NON-CARBONATED SOFT DRINKS IN WHOLE OR SUBSTANTIAL PART OF ORGANIC MATERIALS (U.S. CLS. 45, 46 AND 48).

Michael Tanner, Examining Attorney

SN 85-252,805. MICHAEL B. RIZIK JR., OKEMOS, MI. FILED 2-27-2011.

Beggars Brewery

THE MARK CONSISTS OF STANDARD CHARACTERS WITHOUT CLAIM TO ANY PARTICULAR FONT, STYLE, SIZE, OR COLOR.

NO CLAIM IS MADE TO THE EXCLUSIVE RIGHT TO USE "BREWERY", APART FROM THE MARK AS SHOWN.

FOR BEERS (U.S. CLS. 45, 46 AND 48).

Daniel Capshaw, Examining Attorney

CLASS 32—(Continued).

SN 85-259,028. DWIGHT MEMMOTT, FILLMORE, UT. AND DIANE MEMMOTT, FILLMORE, UT. FILED 3-5-2011.

Texas Twisted Drink

THE MARK CONSISTS OF STANDARD CHARACTERS WITHOUT CLAIM TO ANY PARTICULAR FONT, STYLE, SIZE, OR COLOR.

NO CLAIM IS MADE TO THE EXCLUSIVE RIGHT TO USE "DRINK", APART FROM THE MARK AS SHOWN. FOR MIXED FRUIT JUICE (U.S. CLS. 45, 46 AND 48). FIRST USE 7-4-1996; IN COMMERCE 7-4-1996. ELISSA GARBER KON, EXAMINING ATTORNEY

SN 85-260,797. 21ST CENTURY BRANDS LLC, PHOENIX, AZ. FILED 3-8-2011.



OWNER OF U.S. REG. NO. 3,846,553. THE MARK CONSISTS OF THE LETTER "E" SUPERIMPOSED OVER THE DESIGN OF AN ATOMIC MODEL. THE NUMERAL "6" APPEARS IN THE UPPER RIGHT-HAND CORNER OF THE "E".

FOR ENERGY DRINKS (U.S. CLS. 45, 46 AND 48). FIRST USE 2-23-2010; IN COMMERCE 2-23-2010. LESLEY LAMOTHE, EXAMINING ATTORNEY

CLASS 32—(Continued).

SN 85-261,500. WESLEY P. RICHEY, DBA EXSTA BEVERAGE COMPANY, CORONADO, CA. FILED 3-8-2011.



NO CLAIM IS MADE TO THE EXCLUSIVE RIGHT TO USE "Q10", APART FROM THE MARK AS SHOWN.

THE MARK CONSISTS OF THE LETTERS "Q.TEN" CAPITALIZED UNDER THE LETTER "Q" FOLLOWED BY A RAISED NUMBER "10" THAT IS SURROUNDED IN A SQUARE BOX.

FOR CONCENTRATES AND POWDERS USED IN THE PREPARATION OF ENERGY DRINKS AND FRUIT-FLAVORED BEVERAGES; CONCENTRATES, SYRUPS OR POWDERS USED IN THE PREPARATION OF SPORTS AND ENERGY DRINKS; ENERGY DRINKS; FRUIT FLAVORED DRINKS; FRUIT FLAVORED SOFT DRINKS; FRUIT-BASED SOFT DRINKS FLAVORED WITH TEA; NON-ALCOHOLIC DRINKS, NAMELY, ENERGY SHOTS; POP; POWDERS USED IN THE PREPARATION OF FRUIT-BASED BEVERAGES; POWDERS USED IN THE PREPARATION OF ISOTONIC SPORTS DRINKS AND SPORTS BEVERAGES; SPORTS DRINKS; ALL THE AFOREMENTIONED GOODS CONTAINING COENZYME Q10 (U.S. CLS. 45, 46 AND 48).

LINDA POWELL, EXAMINING ATTORNEY

SN 85-266,168. THE BLACK ABBEY BREWING COMPANY, LLC, FRANKLIN, TN. FILED 3-14-2011.



NO CLAIM IS MADE TO THE EXCLUSIVE RIGHT TO USE "BREWING COMPANY", APART FROM THE MARK AS SHOWN.

THE MARK CONSISTS OF THE WORD "THE" IN SMALL STYLIZED LETTERS DEPICTED OVER THE LETTER "B" IN THE WORD "BLACK", ALSO IN STYLIZED LETTERING, WITH THE LETTER "A" IN THE WORD "BLACK" BEING DEPICTED AS A STAINED GLASS WINDOW; THE WORD "ABBAY" IS BELOW THE WORD "BLACK" IN STYLIZED LETTERS WITH THE WORDING "BREWING COMPANY" IN SMALLER STYLIZED LETTERS BELOW "ABBAY", WITH A CROSS DESIGN DEPICTED BETWEEN THE WORDS "BREWING" AND "COMPANY".

FOR BEER (U.S. CLS. 45, 46 AND 48). KATHERINE STOIDES, EXAMINING ATTORNEY

CLASS 32—(Continued).

SN 85-269,064. LIFE SOLUTIONS GROUP, LLC, SAN DIEGO, CA. FILED 3-16-2011.

Voli

THE MARK CONSISTS OF THE STANDARD CAPITAL LETTER "V" FOLLOWED BY THE STANDARD LOWER CASE LETTERS "O" AND "L" FOLLOWED BY THE LOWER CASE LETTER "I" WITH AN ACUTE ACCENT.

THE ENGLISH TRANSLATION OF "VOLI" IN THE MARK IS "FLIGHTS".

FOR POWDERS USED IN THE PREPARATION OF ISOTONIC SPORTS DRINKS AND SPORTS BEVERAGES (U.S. CLS. 45, 46 AND 48).

ANTHONY RINKER, EXAMINING ATTORNEY

SN 85-271,481. IN ZONE BRANDS, INC., SMYRNA, GA. FILED 3-19-2011.

Belly Washers

OWNER OF U.S. REG. NOS. 2,823,383, 2,881,473 AND 3,567,597.

THE MARK CONSISTS OF THE STYLIZED WORDS "BELLY WASHERS".

FOR FRUIT JUICES; FRUIT JUICES AND FRUIT DRINKS; NON-ALCOHOLIC BEVERAGES CONTAINING FRUIT JUICES (U.S. CLS. 45, 46 AND 48).

FIRST USE 6-15-2010; IN COMMERCE 8-15-2010.

JOHN DWYER, EXAMINING ATTORNEY

CLASS 32—(Continued).

SN 85-271,485. IN ZONE BRANDS, INC., SMYRNA, GA. FILED 3-19-2011.

tummy tickler

OWNER OF U.S. REG. NO. 2,643,602.
THE MARK CONSISTS OF THE STYLIZED WORDS "TUMMY TICKLER".

FOR FRUIT JUICES; FRUIT JUICES AND FRUIT DRINKS; NON-ALCOHOLIC BEVERAGES CONTAINING FRUIT JUICES (U.S. CLS. 45, 46 AND 48).

FIRST USE 6-15-2010; IN COMMERCE 8-15-2010.

JOHN DWYER, EXAMINING ATTORNEY

SN 85-271,487. IN ZONE BRANDS, INC., SMYRNA, GA. FILED 3-19-2011.

tummy tickler
TOTS

OWNER OF U.S. REG. NO. 2,643,602.
NO CLAIM IS MADE TO THE EXCLUSIVE RIGHT TO USE "TOTS", APART FROM THE MARK AS SHOWN.

THE MARK CONSISTS OF THE STYLIZED WORDS "TUMMY TICKLER TOTS".

FOR FRUIT JUICES; FRUIT JUICES AND FRUIT DRINKS; NON-ALCOHOLIC BEVERAGES CONTAINING FRUIT JUICES (U.S. CLS. 45, 46 AND 48).

FIRST USE 6-15-2010; IN COMMERCE 8-15-2010.

JOHN DWYER, EXAMINING ATTORNEY

SN 85-271,713. HARTHORN, ALLEN, L, DBA HARPOS ORGANICS, CHICO, CA. FILED 3-20-2011.

OMG OJ

THE MARK CONSISTS OF STANDARD CHARACTERS WITHOUT CLAIM TO ANY PARTICULAR FONT, STYLE, SIZE, OR COLOR.

NO CLAIM IS MADE TO THE EXCLUSIVE RIGHT TO USE "OJ", APART FROM THE MARK AS SHOWN.

FOR ORANGE JUICE (U.S. CLS. 45, 46 AND 48).

FIRST USE 7-17-2010; IN COMMERCE 7-17-2010.

LINDA POWELL, EXAMINING ATTORNEY

CLASS 32—(Continued).

SN 85-273,957. MELORO, MICHAEL, LAFLIN, PA. FILED 3-22-2011.

WARNING

THE MARK CONSISTS OF THE WORD "WARNING" WITH A CIRCLE AROUND THE LETTER "A".
FOR ENERGY DRINKS (U.S. CLS. 45, 46 AND 48).
ALYSSA STEEL, EXAMINING ATTORNEY

SN 85-276,914. PUGZEE'S FARM, LLC, LENOX, MA. FILED 3-25-2011.

PUGZEE'S FARM

THE MARK CONSISTS OF STANDARD CHARACTERS WITHOUT CLAIM TO ANY PARTICULAR FONT, STYLE, SIZE, OR COLOR.

NO CLAIM IS MADE TO THE EXCLUSIVE RIGHT TO USE "FARM", APART FROM THE MARK AS SHOWN.

FOR FRUIT AND VEGETABLE JUICES AND NON-ALCOHOLIC CIDERS (U.S. CLS. 45, 46 AND 48).
GEOFFREY FOSDICK, EXAMINING ATTORNEY

SN 85-277,610. BOUNDARY WATERS BRANDS, LLC, MINNEAPOLIS, MN. FILED 3-25-2011.

JOIA

THE MARK CONSISTS OF STANDARD CHARACTERS WITHOUT CLAIM TO ANY PARTICULAR FONT, STYLE, SIZE, OR COLOR.

THE ENGLISH TRANSLATION OF "JOIA" IS "JEWEL".
FOR SOFT DRINKS, NAMELY, SODAS (U.S. CLS. 45, 46 AND 48).

MARTHA SANTOMARTINO, EXAMINING ATTORNEY

CLASS 32—(Continued).

SN 85-280,800. BALORU S.A., GUAYAQUIL, ECUADOR, FILED 3-30-2011.



OWNER OF U.S. REG. NOS. 3,927,391 AND 3,927,392.
NO CLAIM IS MADE TO THE EXCLUSIVE RIGHT TO USE "SABOR" OR "PIÑA", APART FROM THE MARK AS SHOWN.

THE COLOR(S) WHITE, RED, BLUE, YELLOW IS/ARE CLAIMED AS A FEATURE OF THE MARK.

THE MARK CONSISTS OF THE WORDING "BALORU SABOR TROPICAL PINA", APPEARING OVER A DESIGN COMPRISED OF A YELLOW AND RED OVAL IN THE FOREGROUND AND A BACKGROUND CONSISTING OF YELLOW SWIRLING OVALS WITH TRAILS COMPRISED OF MANY SMALL DIAMOND SHAPES, WITH AN ABSTRACT TRIANGULAR DOT DESIGN APPEARING ABOVE THE WORD "BALORU". THE COLOR RED APPEARS IN THE TRIANGULAR DOT DESIGN ABOVE THE WORD "BALORU". THE OUTLINE OF THE WORD "BALORU", THE WORD "PIÑA", AND IN A RING OUTLINING THE YELLOW OVAL. THE COLOR WHITE APPEARS IN THE WORD "BALORU" AND THE OUTLINE OF THE WORD "TROPICAL". THE COLOR BLUE APPEARS IN THE WORDING "SABOR TROPICAL". THE COLOR YELLOW APPEARS IN THE OVAL AT THE CENTER OF THE DESIGN, AND IN THE SWIRLING BACKGROUND DESIGN.

THE ENGLISH TRANSLATION OF THE WORDS "SABOR" AND "PIÑA" IN THE MARK IS FLAVOR AND PINEAPPLE. THE WORDING "BALORU" HAS NO MEANING IN A FOREIGN LANGUAGE.

FOR SOFT DRINKS; SYRUPS FOR MAKING SOFT DRINKS (U.S. CLS. 45, 46 AND 48).

MORGAN WYNNE, EXAMINING ATTORNEY

SN 85-280,809. BALORU S.A., GUAYAQUIL, ECUADOR, FILED 3-30-2011.



OWNER OF U.S. REG. NOS. 3,927,391 AND 3,927,392.
NO CLAIM IS MADE TO THE EXCLUSIVE RIGHT TO USE "SABOR", APART FROM THE MARK AS SHOWN.

THE COLOR(S) WHITE, RED, BLUE, YELLOW IS/ARE CLAIMED AS A FEATURE OF THE MARK.

THE MARK CONSISTS OF THE WORDING "BALORU SABOR TROPICAL TUTTI FRUTTI", APPEARING OVER A DESIGN COMPRISED OF A YELLOW AND RED OVAL IN

CLASS 32—(Continued).

THE FOREGROUND AND A BACKGROUND CONSISTING OF BLUE SWIRLING OVALS WITH TRAILS COMPRISED OF MANY SMALL DIAMOND SHAPES, WITH AN ABSTRACT TRIANGULAR DOT DESIGN APPEARING ABOVE THE WORD "BALORU". THE COLOR RED APPEARS IN THE TRIANGULAR DOT DESIGN ABOVE THE WORD "BALORU", THE OUTLINE OF THE WORD "BALORU", THE WORD "TUTTIFRUTTI", AND IN A RING OUTLINING THE YELLOW OVAL. THE COLOR WHITE APPEARS IN THE WORD "BALORU" AND THE OUTLINE OF THE WORD "TROPICAL". THE COLOR BLUE APPEARS IN THE WORDING "SABOR TROPICAL" AND IN THE SWIRLING BACKGROUND DESIGN.

THE ENGLISH TRANSLATION OF "SABOR" IN THE MARK IS "FLAVOR". THE WORDING "BALORU" HAS NO MEANING IN A FOREIGN LANGUAGE.

FOR SOFT DRINKS; SYRUPS FOR MAKING SOFT DRINKS (U.S. CLS. 45, 46 AND 48).

MORGAN WYNNE, EXAMINING ATTORNEY

SN 85-280,816. BALORU S.A., GUAYAQUIL, ECUADOR, FILED 3-30-2011.



OWNER OF U.S. REG. NOS. 3,927,392, 3,946,679 AND OTHERS.

NO CLAIM IS MADE TO THE EXCLUSIVE RIGHT TO USE "SABOR MANZANA", APART FROM THE MARK AS SHOWN.

THE COLOR(S) GREEN, WHITE, ORANGE IS/ARE CLAIMED AS A FEATURE OF THE MARK.

THE MARK CONSISTS OF THE WORDING "BALORU SABOR MANZANA", APPEARING OVER AN ORANGE SQUARE BACKGROUND CARRIER, WITH AN ABSTRACT TRIANGULAR DOT DESIGN APPEARING ABOVE THE WORD "BALORU", SIX CIRCLES OF VARIOUS SIZES TO THE LEFT OF THE WORD "SABOR", AND FOUR STRAIGHT LINES AND BUBBLES UNDERNEATH THE WORD "MANZANA", WHICH WORD IS SUPERIMPOSED OVER A WHITE BACKGROUND CARRIER. THE COLOR GREEN APPEARS IN ABSTRACT TRIANGULAR DOT DESIGN ABOVE THE WORD "BALORU", THREE OF THE CIRCLES TO THE LEFT OF THE WORD "SABOR", A LINE OUTLINING THE PERIMETER OF THE WORD "MANZANA", THE FOUR HORIZONTAL LINES UNDER THE WORD "MANZANA", THE OUTLINE OF THE WORD "BALORU", AND IN THE BUBBLES. THE COLOR WHITE APPEARS IN THE WORD "BALORU", THREE OF THE CIRCLES TO THE LEFT OF THE WORD "SABOR", THE BACKGROUND UNDER THE WORD "MANZANA", AND IN THE BUBBLES. THE COLOR ORANGE APPEARS IN THE SQUARE BACKGROUND CARRIER, THE WORD "MANZANA" AND IN THE BUBBLES.

THE ENGLISH TRANSLATION OF "SABOR" AND "MANZANA" IN THE MARK IS "FLAVOR" AND "APPLE". THE WORDING "BALORU" HAS NO MEANING IN A FOREIGN LANGUAGE.

FOR SOFT DRINKS; SYRUPS FOR MAKING SOFT DRINKS (U.S. CLS. 45, 46 AND 48).

MORGAN WYNNE, EXAMINING ATTORNEY

CLASS 32—(Continued).

SN 85-287,107. NIAGARA BOTTLING, LLC, SANTA BARBARA, CA. FILED 4-5-2011.

GAME PLAN

THE MARK CONSISTS OF STANDARD CHARACTERS WITHOUT CLAIM TO ANY PARTICULAR FONT, STYLE, SIZE, OR COLOR.

FOR BOTTLED DRINKING WATER; BOTTLED WATER; DRINKING WATER; DRINKING WATER WITH VITAMINS; DRINKING WATERS; ENERGY DRINKS; FLAVORED BOTTLED WATER; FLAVORED ENHANCED WATER; FLAVORED WATERS; FLAVOURED WATERS; FRUIT DRINKS; FRUIT DRINKS AND FRUIT JUICES; FRUIT DRINKS AND JUICES; FRUIT FLAVORED DRINKS; FRUIT FLAVORED SOFT DRINKS; FRUIT FLAVOURED DRINKS; FRUIT JUICES AND FRUIT DRINKS; FRUIT-FLAVORED BEVERAGES; ISOTONIC DRINKS; SOFT DRINKS; SOFT DRINKS, NAMELY, NAMELY, VITAMIN ENHANCED FLAVORED DRINKING WATER; SPORTS DRINKS; SPORTS DRINKS CONTAINING ELECTROLYTES; SPORTS DRINKS, NAMELY, ENERGY DRINKS (U.S. CLS. 45, 46 AND 48).

HENRY S. ZAK, EXAMINING ATTORNEY

SN 85-287,425. ADAM M. BAK, BROOKLYN, NY. FILED S.R. 4-6-2011; AM. P.R. 7-7-2011.



THE MARK CONSISTS OF "PERUN" AND A SUN DESIGN.

THE WORDING "PERUN" HAS NO MEANING IN A FOREIGN LANGUAGE.

FOR SPARKLING WATER; SPRING WATER (U.S. CLS. 45, 46 AND 48).

FIRST USE 4-1-2011; IN COMMERCE 4-1-2011.

JOHN HWANG, EXAMINING ATTORNEY

CLASS 32—(Continued).

SN 85-287,528. THE BRONX BREWERY, LLC, NEW YORK, NY. FILED 4-6-2011.



THE COLOR(S) BLACK, WHITE AND GOLD IS/ARE CLAIMED AS A FEATURE OF THE MARK.

THE MARK CONSISTS OF THE LETTERS "BxB", IN A BLACK CUSTOM FONT WITH WHITE SLOTTES, DIAGONALLY-ORIENTED LEFT-TO-RIGHT AT A SLIGHT DOWNWARD ANGLE, WITH "B" AT THE UPPER LEFT, "X" IN THE MIDDLE AND "B" AT THE LOWER RIGHT, WITH A THIN GOLD BAR COMING OUT OF BOTH THE LEFT AND RIGHT SIDES, VERTICALLY CENTERED AT THE MIDDLE OF THE LOGO, TAPERING TO A POINT AWAY FROM THE LETTERS.

FOR BEER; BEER, ALE AND LAGER; BEER, ALE AND PORTER; BEER, ALE, LAGER, STOUT AND PORTER; BEER, ALE, LAGER, STOUT, PORTER, SHANDY; BEERS; BLACK BEER; BREWED MALT-BASED ALCOHOLIC BEVERAGE IN THE NATURE OF A BEER; COFFEE-FLAVORED BEER; DE-ALCOHOLISED BEER; EXTRACTS OF HOPS FOR MAKING BEER; FLAVORED BEERS; GINGER BEER; HOP EXTRACTS FOR MANUFACTURING BEER; IMITATION BEER; MALT BEER; MALT EXTRACTS FOR MAKING BEER; MALT LIQUOR; NON-ALCOHOLIC BEER; PALE BEER; PORTER (U.S. CLS. 45, 46 AND 48).

THOMAS MANOR, EXAMINING ATTORNEY

SN 85-291,125. SWATER, INC., MALDEN, MA. FILED 4-10-2011.

Swater

THE MARK CONSISTS OF STANDARD CHARACTERS WITHOUT CLAIM TO ANY PARTICULAR FONT, STYLE, SIZE, OR COLOR.

FOR BOTTLED WATER (U.S. CLS. 45, 46 AND 48).
MICHELE SWAIN, EXAMINING ATTORNEY

SN 85-291,788. MAD SCIENTISTS BREWING PARTNERS LLC, DBA SIXPOINT CRAFT ALES, BROOKLYN, NY. FILED 4-11-2011.

ESPRIT DE CORPS

THE MARK CONSISTS OF STANDARD CHARACTERS WITHOUT CLAIM TO ANY PARTICULAR FONT, STYLE, SIZE, OR COLOR.

FOR BEER (U.S. CLS. 45, 46 AND 48).
FIRST USE 4-5-2011; IN COMMERCE 4-5-2011.
ROSELLE HERRERA, EXAMINING ATTORNEY

CLASS 32—(Continued).

SN 85-292,069. SIERRA NEVADA BREWING CO., CHICO, CA. FILED 4-11-2011.

FOAM

THE MARK CONSISTS OF STANDARD CHARACTERS WITHOUT CLAIM TO ANY PARTICULAR FONT, STYLE, SIZE, OR COLOR.

FOR BEER AND ALE (U.S. CLS. 45, 46 AND 48).
FIRST USE 10-30-2009; IN COMMERCE 10-30-2009.
ANGELA DUONG, EXAMINING ATTORNEY

SN 85-292,384. FLAVOR 4 U, LLC, PACIFIC PALISADES, CA. FILED 4-12-2011.

DO YOURSELF A FLAVOR!

THE MARK CONSISTS OF STANDARD CHARACTERS WITHOUT CLAIM TO ANY PARTICULAR FONT, STYLE, SIZE, OR COLOR.

FOR CONCENTRATES, SYRUPS AND POWDERS USED IN THE PREPARATION OF ENERGY DRINKS AND FRUIT-FLAVORED BEVERAGES (U.S. CLS. 45, 46 AND 48).

IRA J. GOODSID, EXAMINING ATTORNEY

SN 85-293,044. PUGZEE'S FARM, LLC, LENOX, MA. FILED 4-12-2011.



NO CLAIM IS MADE TO THE EXCLUSIVE RIGHT TO USE "FARM" AND "WASHINGTON, MASSACHUSETTS", APART FROM THE MARK AS SHOWN.

THE MARK CONSISTS OF AN OVAL SHAPE WITH THE PHRASE VETERANS HARVESTING HOPE ABOVE IT AND THE PHRASE WASHINGTON, MASSACHUSETTS BELOW IT. THESE PHRASES ARE BOTH FLANKED BY TWO DOTS. THE WORD PUGZEE'S IS WITHIN THE OVAL AT THE TOP AND THE WORD FARM IS ON THE BOTTOM WITHIN THE OVAL. BETWEEN PUGZEE'S AND FARM IS A DRAWING OF A PUG STANDING IN THE MIDDLE WITH A DRAWING OF TWO APPLES TO ITS LEFT AND A DRAWING OF A HONEYDIPPER AND DIPPER TO ITS RIGHT.

FOR FRUIT AND VEGETABLE JUICES AND NON-ALCOHOLIC CIDERS (U.S. CLS. 45, 46 AND 48).
GEOFFREY FOSDICK, EXAMINING ATTORNEY

CLASS 32—(Continued).

SN 85-293,363. PUGZEE'S FARM, LLC, LENOX, MA. FILED 4-12-2011.



NO CLAIM IS MADE TO THE EXCLUSIVE RIGHT TO USE "FARM" AND "WASHINGTON, MASSACHUSETTS", APART FROM THE MARK AS SHOWN.

THE COLOR(S) GREEN, RED, WHITE, GREY, BEIGE AND BROWN IS/ARE CLAIMED AS A FEATURE OF THE MARK.

THE MARK CONSISTS OF A GREEN OVAL SHAPE WITH THE PHRASE "VETERANS HARVESTING HOPE" ABOVE IT AND THE PHRASE "WASHINGTON, MASSACHUSETTS" BELOW IT, BOTH IN GREEN LETTERING. THESE PHRASES ARE BOTH FLANKED BY TWO GREEN DOTS. THE WORD "PUGZEE'S" IN WHITE IS WITHIN THE OVAL AT THE TOP AND THE WORD "FARM" IN WHITE IS WITHIN THE OVAL ON THE BOTTOM. BETWEEN "PUGZEE'S" AND "FARM" IS A DRAWING OF A GREY PUG STANDING IN THE MIDDLE WITH A DRAWING OF TWO RED APPLES WITH GREEN LEAVES AND GREY STEM TO ITS LEFT AND A DRAWING OF A BEIGE AND BROWN HONEYPOT AND A BEIGE DIPPER TO ITS RIGHT.

FOR FRUIT AND VEGETABLE JUICES AND NON-ALCOHOLIC CIDERS (U.S. CLS. 45, 46 AND 48).

GEOFFREY FOSDICK, EXAMINING ATTORNEY

SN 85-293,367. WINE BY JOE, LLC, DUNDEE, OR. FILED 4-12-2011.

BEER BY JOE

THE MARK CONSISTS OF STANDARD CHARACTERS WITHOUT CLAIM TO ANY PARTICULAR FONT, STYLE, SIZE, OR COLOR.

OWNER OF U.S. REG. NO. 2,924,180. NO CLAIM IS MADE TO THE EXCLUSIVE RIGHT TO USE "BEER", APART FROM THE MARK AS SHOWN.

FOR BEER (U.S. CLS. 45, 46 AND 48).
IRA J. GOODSAD, EXAMINING ATTORNEY

CLASS 32—(Continued).

SN 85-293,620. BALORU S.A., GUAYAQUIL, ECUADOR, FILED 4-13-2011.



OWNER OF U.S. REG. NOS. 3,927,391 AND 3,927,392. NO CLAIM IS MADE TO THE EXCLUSIVE RIGHT TO USE "SABOR", APART FROM THE MARK AS SHOWN.

THE COLOR(S) WHITE, RED, BLUE, AND YELLOW IS/ARE CLAIMED AS A FEATURE OF THE MARK.

THE MARK CONSISTS OF THE WORDING "BALORU SABOR TROPICAL ORO", APPEARING OVER A DESIGN COMPRISED OF A YELLOW AND RED OVAL IN THE FOREGROUND AND A BACKGROUND CONSISTING OF BLUE SWIRLING OVALS WITH TRAILS COMPRISED OF MANY SMALL DIAMOND SHAPES, WITH AN ABSTRACT TRIANGULAR DOT DESIGN APPEARING ABOVE THE WORD "BALORU". THE COLOR RED APPEARS IN THE TRIANGULAR DOT DESIGN ABOVE THE WORD "BALORU", THE OUTLINE OF THE WORD "BALORU", THE WORD "ORO", AND IN A RING OUTLINING THE YELLOW OVAL. THE COLOR WHITE APPEARS IN THE WORD "BALORU" AND THE OUTLINE OF THE WORD "TROPICAL". THE COLOR BLUE APPEARS IN THE WORDING "SABOR TROPICAL" AND IN THE SWIRLING BACKGROUND DESIGN.

THE ENGLISH TRANSLATION OF "SABOR" AND "ORO" IN THE MARK IS "FLAVOR" AND "GOLD". THE WORDING "BALORU" HAS NO MEANING IN A FOREIGN LANGUAGE.

FOR SOFT DRINKS; SYRUPS FOR MAKING SOFT DRINKS (U.S. CLS. 45, 46 AND 48).

MORGAN WYNNE, EXAMINING ATTORNEY

SN 85-294,157. MOTHER EARTH BREWING, LLC, KINSTON, NC. FILED 4-13-2011.

SECOND WIND

THE MARK CONSISTS OF STANDARD CHARACTERS WITHOUT CLAIM TO ANY PARTICULAR FONT, STYLE, SIZE, OR COLOR.

FOR BEER; BREWED MALT-BASED ALCOHOLIC BEVERAGE IN THE NATURE OF A BEER (U.S. CLS. 45, 46 AND 48).

DOMINICK J. SALEMI, EXAMINING ATTORNEY

CLASS 32—(Continued).

SN 85-294,167. MOTHER EARTH BREWING, LLC, KINSTON, NC. FILED 4-13-2011.

SUNNY HAZE

THE MARK CONSISTS OF STANDARD CHARACTERS WITHOUT CLAIM TO ANY PARTICULAR FONT, STYLE, SIZE, OR COLOR.

FOR BEER; BREWED MALT-BASED ALCOHOLIC BEVERAGE IN THE NATURE OF A BEER (U.S. CLS. 45, 46 AND 48).

DOMINICK J. SALEMI, EXAMINING ATTORNEY

SN 85-294,530. DR PEPPER/SEVEN UP, INC., PLANO, TX. FILED 4-13-2011.

ALOHA MORNING

THE MARK CONSISTS OF STANDARD CHARACTERS WITHOUT CLAIM TO ANY PARTICULAR FONT, STYLE, SIZE, OR COLOR.

FOR CONCENTRATES FOR MAKING FRUIT DRINKS; FRUIT FLAVORED DRINKS (U.S. CLS. 45, 46 AND 48).

MIDGE BUTLER, EXAMINING ATTORNEY

SN 85-295,620. INCOMMAND LLC, MIDDLETOWN, OH. FILED 4-14-2011.

KLOTTER & SOHN

THE MARK CONSISTS OF STANDARD CHARACTERS WITHOUT CLAIM TO ANY PARTICULAR FONT, STYLE, SIZE, OR COLOR.

FOR BEER (U.S. CLS. 45, 46 AND 48).

WON TEAK OH, EXAMINING ATTORNEY

CLASS 32—(Continued).

SN 85-295,635. EVIVA CONCEPTS, INC., RANCHO PALOS VERDES, CA. FILED 4-14-2011.



THE MARK CONSISTS OF THE WORD "EVIVA" IN LOWERCASE LETTERS WHERE THE FIRST LETTER E IS MADE WITH AN UPSIDE DOWN LETTER A AND THE LETTER I HAS TWO DOTS, ONE ABOVE IT AND ONE UNDER IT, IN ORDER TO GIVE A SYMMETRICAL IMPRESSION.

FOR BOTTLED DRINKING WATER (U.S. CLS. 45, 46 AND 48).

KRISTIN CARLSON, EXAMINING ATTORNEY

SN 85-295,782. ADVANCED FOOD CONCEPTS, INCORPORATED, BERKELEY, CA. FILED 4-14-2011.

ROCTANE

THE MARK CONSISTS OF STANDARD CHARACTERS WITHOUT CLAIM TO ANY PARTICULAR FONT, STYLE, SIZE, OR COLOR.

OWNER OF U.S. REG. NO. 3,636,337.

FOR NON-ALCOHOLIC BEVERAGES, NAMELY, SPORTS DRINKS INFUSED WITH MALTODEXTRIN, PROTEIN, CARBOHYDRATES, VITAMINS AND ELECTROLYTES; ENERGY DRINKS; SPORTS DRINKS; CONCENTRATES, TABLETS AND POWDERS FOR USE IN PREPARATION OF SPORTS DRINKS (U.S. CLS. 45, 46 AND 48).

DORITT L. CARROLL, EXAMINING ATTORNEY

SN 85-296,993. ROBERT WALDER, PLAINFIELD, VT. FILED 4-15-2011.

Fizzleblitz

THE MARK CONSISTS OF STANDARD CHARACTERS WITHOUT CLAIM TO ANY PARTICULAR FONT, STYLE, SIZE, OR COLOR.

FOR NON-ALCOHOLIC BEVERAGES, NAMELY, CARBONATED BEVERAGES (U.S. CLS. 45, 46 AND 48).

FIRST USE 1-1-2011; IN COMMERCE 1-1-2011.

GIANCARLO CASTRO, EXAMINING ATTORNEY

CLASS 32—(Continued).

SN 85-299,870. RIO JOE'S BRANDS, INC., VALLEY VIL-
LAGE, CA. FILED 4-20-2011.

Saude

THE MARK CONSISTS OF STANDARD CHARACTERS
WITHOUT CLAIM TO ANY PARTICULAR FONT, STYLE,
SIZE, OR COLOR.
THE ENGLISH TRANSLATION OF "SAUDE" IN THE
MARK IS "HEALTH".
FOR BEER, ALE, LAGER, STOUT AND PORTER (U.S.
CLS. 45, 46 AND 48).
JILL PRATER, EXAMINING ATTORNEY

SN 85-305,128. BOUNDARY WATERS BRANDS, LLC, MIN-
NEAPOLIS, MN. FILED 4-26-2011.

JOYA

THE MARK CONSISTS OF STANDARD CHARACTERS
WITHOUT CLAIM TO ANY PARTICULAR FONT, STYLE,
SIZE, OR COLOR.
THE ENGLISH TRANSLATION OF "JOYA" IS "JEWEL".
FOR SOFT DRINKS, NAMELY, SODAS (U.S. CLS. 45,
46 AND 48).
MARTHA SANTOMARTINO, EXAMINING ATTORNEY

SN 85-306,888. BALORU S.A., GUAYAQUIL, ECUADOR,
FILED 4-28-2011.



OWNER OF U.S. REG. NO. 1,474,395.
NO CLAIM IS MADE TO THE EXCLUSIVE RIGHT TO
USE "PURO SABOR", APART FROM THE MARK AS
SHOWN.
THE MARK CONSISTS OF THE WORDING "PURO
SABOR NACIONAL", ALL IN LOWER CASE EXCEPT THE
"N" IN "NACIONAL" WITH THE WORDS ARRANGED IN A
WAVE SHAPE.
THE ENGLISH TRANSLATION OF "PURO SABOR NA-
CIONAL" IN THE MARK IS "REAL NATIONAL FLAVOR".
FOR SOFT DRINKS; SYRUPS FOR MAKING SOFT
DRINKS (U.S. CLS. 45, 46 AND 48).
MORGAN WYNNE, EXAMINING ATTORNEY

CLASS 32—(Continued).

SN 85-306,996. BALORU S.A., GUAYAQUIL, ECUADOR,
FILED 4-28-2011.

PURO SABOR NACIONAL

THE MARK CONSISTS OF STANDARD CHARACTERS
WITHOUT CLAIM TO ANY PARTICULAR FONT, STYLE,
SIZE, OR COLOR.
OWNER OF U.S. REG. NO. 1,474,395.
NO CLAIM IS MADE TO THE EXCLUSIVE RIGHT TO
USE "PURO SABOR", APART FROM THE MARK AS
SHOWN.
THE ENGLISH TRANSLATION OF "PURO SABOR NA-
CIONAL" IN THE MARK IS "REAL NATIONAL FLAVOR".
FOR SOFT DRINKS; SYRUPS FOR MAKING SOFT
DRINKS (U.S. CLS. 45, 46 AND 48).
MORGAN WYNNE, EXAMINING ATTORNEY

SN 85-313,397. BOULEVARD BREWING ASSOCIATES LIM-
ITED PARTNERSHIP, DBA BOULEVARD BREWING
COMPANY, KANSAS CITY, MO. FILED 5-5-2011.

Love Child

THE MARK CONSISTS OF STANDARD CHARACTERS
WITHOUT CLAIM TO ANY PARTICULAR FONT, STYLE,
SIZE, OR COLOR.
FOR BEER, ALE AND MALT LIQUOR (U.S. CLS. 45, 46
AND 48).
STEVEN PEREZ, EXAMINING ATTORNEY

SN 85-316,440. MCKENZIE RIVER CORPORATION, SAN
FRANCISCO, CA. FILED 5-10-2011.

ALCOWATER

THE MARK CONSISTS OF STANDARD CHARACTERS
WITHOUT CLAIM TO ANY PARTICULAR FONT, STYLE,
SIZE, OR COLOR.
FOR ALE; BEER (U.S. CLS. 45, 46 AND 48).
VERNA BETH RIRIE, EXAMINING ATTORNEY

CLASS 32—(Continued).

SN 85-316,442. MCKENZIE RIVER CORPORATION, SAN FRANCISCO, CA. FILED 5-10-2011.

ALCO-WATER

THE MARK CONSISTS OF STANDARD CHARACTERS WITHOUT CLAIM TO ANY PARTICULAR FONT, STYLE, SIZE, OR COLOR.

FOR ALE; BEER (U.S. CLS. 45, 46 AND 48).
VERNA BETH RIRIE, EXAMINING ATTORNEY

SN 85-320,320. THE COCA-COLA COMPANY, ATLANTA, GA. FILED 5-13-2011.

MORE FANTA, LESS SERIOUS

THE MARK CONSISTS OF STANDARD CHARACTERS WITHOUT CLAIM TO ANY PARTICULAR FONT, STYLE, SIZE, OR COLOR.

OWNER OF U.S. REG. NOS. 513,565, 3,011,381 AND OTHERS.

FOR SOFT DRINKS (U.S. CLS. 45, 46 AND 48).
AMY C. KEAN, EXAMINING ATTORNEY

SN 85-321,307. BLUEPRINTCLEANSE LLC, NEW YORK, NY. FILED 5-15-2011.

BluePrintKit

THE MARK CONSISTS OF STANDARD CHARACTERS WITHOUT CLAIM TO ANY PARTICULAR FONT, STYLE, SIZE, OR COLOR.

OWNER OF U.S. REG. NO. 3,523,499.

FOR FRUIT BEVERAGES; FRUIT JUICES AND FRUIT DRINKS; NON-ALCOHOLIC BEVERAGES CONTAINING FRUIT JUICES; NON-ALCOHOLIC FRUIT EXTRACTS USED IN THE PREPARATION OF BEVERAGES; NON-ALCOHOLIC FRUIT JUICE BEVERAGES; PREPARED ENTREES CONSISTING OF FRUIT DRINKS AND FRUIT JUICES, FRUIT-BASED BEVERAGES, NON-ALCOHOLIC BEVERAGES CONTAINING FRUIT JUICES, NON-ALCOHOLIC FRUIT EXTRACTS USED IN THE PREPARATION OF BEVERAGES, NON-ALCOHOLIC FRUIT JUICE BEVERAGES, VEGETABLE JUICES, VEGETABLE-FRUIT JUICES AND SMOOTHIES; VEGETABLE DRINKS; VEGETABLE JUICE; VEGETABLE JUICES; VEGETABLE-FRUIT JUICES (U.S. CLS. 45, 46 AND 48).

FIRST USE 12-9-2010; IN COMMERCE 12-9-2010.
KATINA MISTER, EXAMINING ATTORNEY

CLASS 32—(Continued).

SN 85-321,372. ZETA ORGANIC NEW ZEALAND LIMITED, OREWA AUCKLAND, NEW ZEALAND, FILED 5-16-2011.

ZIWI

THE MARK CONSISTS OF STANDARD CHARACTERS WITHOUT CLAIM TO ANY PARTICULAR FONT, STYLE, SIZE, OR COLOR.

FOR FRUIT JUICES; FRUIT NECTARS; FRUIT BASED BEVERAGES; VEGETABLE JUICE BEVERAGES; ORGANIC FRUIT JUICES; SYRUPS AND PREPARATIONS FOR MAKING BEVERAGES; CARBONATED FRUIT JUICES; FRESH AND CONCENTRATED FRUIT JUICES; FRESH AND CONCENTRATED VEGETABLE JUICES; SOFT DRINKS; LEMONADE; FRUIT PUNCH; SPORTS DRINKS; SPARKLING WATER; MINERAL WATER; SPRING WATER AND BOTTLED DRINKING WATER; FRESH AND CONCENTRATED FRUIT AND VEGETABLE JUICE COMBINATIONS; SPORTS DRINKS; COCONUT WATER; ALOE VERA DRINKS (U.S. CLS. 45, 46 AND 48).

GINA HAYES, EXAMINING ATTORNEY

SN 85-321,789. BOSTON BEER CORPORATION, BOSTON, MA. FILED 5-16-2011.

MAD SCATTER

THE MARK CONSISTS OF STANDARD CHARACTERS WITHOUT CLAIM TO ANY PARTICULAR FONT, STYLE, SIZE, OR COLOR.

FOR ALE; BEER (U.S. CLS. 45, 46 AND 48).
LINDA POWELL, EXAMINING ATTORNEY

SN 85-344,812. HO-CHUNK NATION, BLACK RIVER FALLS, WI. FILED 6-13-2011.

Niisini

THE MARK CONSISTS OF STANDARD CHARACTERS WITHOUT CLAIM TO ANY PARTICULAR FONT, STYLE, SIZE, OR COLOR.

OWNER OF U.S. REG. NO. 2,988,625.
FOR BEVERAGES, NAMELY, DRINKING WATER (U.S. CLS. 45, 46 AND 48).

FIRST USE 2-1-2011, THE MARK WAS FIRST USED ANYWHERE IN A DIFFERENT FORM OTHER THAN THAT SOUGHT TO BE REGISTERED AT LEAST AS EARLY AS 04/00/2003.; IN COMMERCE 2-1-2011, THE MARK WAS FIRST USED IN COMMERCE IN A DIFFERENT FORM OTHER THAN THAT SOUGHT TO BE REGISTERED AT LEAST AS EARLY AS 04/00/2003..

KATHLEEN M. VANSTON, EXAMINING ATTORNEY

CLASS 33—WINES AND SPIRITS

SN 77-604,245. DOMAINES OTT, LA LONDE, FRANCE,
FILED 10-30-2008.



NO CLAIM IS MADE TO THE EXCLUSIVE RIGHT TO USE "BLANC", "CLOS" AND "COTES" AND THE SHAPE OF THE BOTTLE AND CAP, APART FROM THE MARK AS SHOWN.

THE COLOR(S) GOLD, YELLOW, RED AND BLACK IS/ ARE CLAIMED AS A FEATURE OF THE MARK.

THE MARK CONSISTS OF A THREE-DIMENSIONAL CONFIGURATION OF A WINE BOTTLE MADE OF CLEAR GLASS WITH A WIDE-MOUTHED TOP, TWO SEPARATE GLASS RINGS AROUND THE NECK OF THE BOTTLE, THE LOWER ONE BEING BIGGER THAN THE UPPER ONE, AND AN ENLARGED FLAT BOTTOM. A GOLD FOIL COVERS THE TOP OF THE BOTTLE AND A PORTION OF THE UPPER GLASS RING. BELOW THE GOLD FOIL AND BETWEEN THE TWO GLASS RINGS IS A YELLOW LABEL. BELOW THE LOWER GLASS RING AROUND THE NECK OF THE BOTTLE IS A YELLOW LABEL WITH THE WORDS: "CLOS MIREILLE" IN RED, "DOMAINES" IN A BLACK SCRIPT FONT, AND "OTT" IN A SCRIPT FONT. A STAR IS LOCATED AFTER THE WORD "OTT." A YELLOW BANNER EXTENDS DIAGONALLY ACROSS THE LOWER PORTION OF THE BOTTLE WITH THE WORDS "BLANC DE BLANCS" IN A BLACK SCRIPT FONT. ABOVE AND BELOW THE WORDS "BLANC DE BLANCS" ON THE DIAGONAL LABEL ARE THE WORDS "COTES DE PROVENCE" IN A RED, BASIC FONT.

THE ENGLISH TRANSLATION OF "BLANC DE BLANCS CLOS MIREILLE DOMAINES OTT COTES DE PROVENCE" IN THE MARK IS WHITE OF WHITES (IS "BLANC DE BLANCS"); MIREILLE VINEYARD (IS "CLOS MIREILLE") (DOMAINES OTT IS APPLICANT'S NAME), PROVENCE HILLS (IS "COTES DE PROVENCE").

FOR WINES (U.S. CLS. 47 AND 49).
FIRST USE 11-30-2006; IN COMMERCE 11-30-2006.
GINA HAYES, EXAMINING ATTORNEY

CLASS 33—(Continued).

SN 77-690,276. STRANGER & STRANGER LTD, LONDON,
UNITED KINGDOM, FILED 3-13-2009.

SERPIENTE

THE MARK CONSISTS OF STANDARD CHARACTERS WITHOUT CLAIM TO ANY PARTICULAR FONT, STYLE, SIZE, OR COLOR.

OWNER OF UNITED KINGDOM REG. NO. 2510413,
DATED 3-6-2009, EXPIRES 3-6-2019.

THE ENGLISH TRANSLATION OF THE WORD "SERPIENTE" IN THE MARK IS "SERPENT".
FOR ALCOHOLIC BEVERAGES EXCEPT BEERS (U.S. CLS. 47 AND 49).

ESTHER A. BORSUK, EXAMINING ATTORNEY

SN 77-690,297. STRANGER & STRANGER LTD, LONDON,
UNITED KINGDOM, FILED 3-13-2009.

NUEVA OLA

THE MARK CONSISTS OF STANDARD CHARACTERS WITHOUT CLAIM TO ANY PARTICULAR FONT, STYLE, SIZE, OR COLOR.

OWNER OF UNITED KINGDOM REG. NO. 2510418,
DATED 3-6-2009, EXPIRES 3-6-2019.

THE ENGLISH TRANSLATION OF THE WORD "NUEVA OLA" IN THE MARK IS "NEW WAVE".
FOR ALCOHOLIC BEVERAGES EXCEPT BEERS (U.S. CLS. 47 AND 49).

ESTHER A. BORSUK, EXAMINING ATTORNEY

SN 77-690,366. STRANGER & STRANGER LTD, LONDON,
UNITED KINGDOM, FILED 3-13-2009.

EL CORTE

THE MARK CONSISTS OF STANDARD CHARACTERS WITHOUT CLAIM TO ANY PARTICULAR FONT, STYLE, SIZE, OR COLOR.

OWNER OF UNITED KINGDOM REG. NO. 2510417,
DATED 3-6-2009, EXPIRES 3-6-2019.

THE ENGLISH TRANSLATION OF THE WORD "EL CORTE" IN THE MARK IS "THE COURT".
FOR ALCOHOLIC BEVERAGES EXCEPT BEERS (U.S. CLS. 47 AND 49).

ESTHER A. BORSUK, EXAMINING ATTORNEY

CLASS 33—(Continued).

SN 79-080,959. HUGH HAMILTON WINES PTY LTD, AUSTRALIA, FILED 3-10-2010.

Jekyll & Hyde

THE MARK CONSISTS OF STANDARD CHARACTERS WITHOUT CLAIM TO ANY PARTICULAR FONT, STYLE, SIZE, OR COLOR.

OWNER OF INTERNATIONAL REGISTRATION 1034379 DATED 3-10-2010, EXPIRES 3-10-2020.
FOR WINES (U.S. CLS. 47 AND 49).
SHARON MEIER, EXAMINING ATTORNEY

CLASS 33—(Continued).

SN 79-088,031. SOCIETE D'EXPLOITATION DU CHATEAU SOUTARD, F-33330 SAINT-EMILION, FRANCE, FILED 9-15-2010.

CHATEAU SOUTARD

THE MARK CONSISTS OF STANDARD CHARACTERS WITHOUT CLAIM TO ANY PARTICULAR FONT, STYLE, SIZE, OR COLOR.

OWNER OF INTERNATIONAL REGISTRATION 1052995 DATED 9-15-2010, EXPIRES 9-15-2020.

NO CLAIM IS MADE TO THE EXCLUSIVE RIGHT TO USE "CHATEAU", APART FROM THE MARK AS SHOWN. THE WORDING "SOUTARD" HAS NO MEANING IN A FOREIGN LANGUAGE.

FOR AOC WINES, NAMELY, WINES WITH PROTECTED APPELLATION OF ORIGIN (U.S. CLS. 47 AND 49).

MYRIAH HABEEB, EXAMINING ATTORNEY

SN 79-088,032. SOCIETE D'EXPLOITATION DU CHATEAU SOUTARD, FRANCE, FILED 9-15-2010.

Les Jardins de Soutard

THE MARK CONSISTS OF STANDARD CHARACTERS WITHOUT CLAIM TO ANY PARTICULAR FONT, STYLE, SIZE, OR COLOR.

OWNER OF INTERNATIONAL REGISTRATION 1052997 DATED 9-15-2010, EXPIRES 9-15-2020.

THE ENGLISH TRANSLATION OF "LES JARDINS DE SOUTARD" IN THE MARK IS "THE GARDENS OF SOUTARD". THE WORDING "SOUTARD" HAS NO MEANING IN A FOREIGN LANGUAGE.

FOR ALCOHOLIC BEVERAGES EXCEPT BEER; HARD CIDER; DIGESTERS, NAMELY, LIQUEURS AND SPIRITS; WINE; SPIRITS; ALCOHOLIC EXTRACTS OR ESSENCES (U.S. CLS. 47 AND 49).

MYRIAH HABEEB, EXAMINING ATTORNEY

SN 79-087,504. ALTADONNA SRL, ITALY, FILED 7-8-2010.



PRIORITY DATE OF 5-14-2010 IS CLAIMED.
OWNER OF INTERNATIONAL REGISTRATION 1051479 DATED 7-8-2010, EXPIRES 7-8-2020.

NO CLAIM IS MADE TO THE EXCLUSIVE RIGHT TO USE "ITALIA", APART FROM THE MARK AS SHOWN.

THE NAME(S), PORTRAIT(S), AND/OR SIGNATURE(S) SHOWN IN THE MARK IDENTIFIES MRS. ANNA ALTADONNA, WHOSE CONSENT(S) TO REGISTER IS MADE OF RECORD.

THE MARK CONSISTS OF A LABEL INCORPORATING THE WORDINGS "ALTADONNA" AT THE TOP AND "ITALIA" AT THE BOTTOM, BOTH WORDS BEING IN SPECIAL CAPITAL LETTERS; IN THE CENTRAL AREA THERE APPEARS A WOMAN'S HEAD SEEN FROM THE SIDE AND PLACED WITHIN A ROUND FRAME DECORATED WITH FANCIFUL DETAILS.

THE WORDING "ALTADONNA" HAS NO MEANING IN A FOREIGN LANGUAGE.

FOR WINES (U.S. CLS. 47 AND 49).

KRISTIN DAHLING, EXAMINING ATTORNEY

SN 79-088,073. SOCIETE D'EXPLOITATION DU CHATEAU SOUTARD, FRANCE, FILED 9-15-2010.

CHATEAU LARMANDE

THE MARK CONSISTS OF STANDARD CHARACTERS WITHOUT CLAIM TO ANY PARTICULAR FONT, STYLE, SIZE, OR COLOR.

OWNER OF INTERNATIONAL REGISTRATION 1053083 DATED 9-15-2010, EXPIRES 9-15-2020.

NO CLAIM IS MADE TO THE EXCLUSIVE RIGHT TO USE "CHATEAU", APART FROM THE MARK AS SHOWN. THE WORDING "LARMANDE" HAS NO MEANING IN A FOREIGN LANGUAGE.

FOR AOC WINES, NAMELY, WINES WITH PROTECTED APPELLATION OF ORIGIN (U.S. CLS. 47 AND 49).

MYRIAH HABEEB, EXAMINING ATTORNEY

CLASS 33—(Continued).

SN 79-089,759. CASA DE STA. VITÓRIA - SOCIEDADE AGRO-INDUSTRIAL, S.A., PORTUGAL, FILED 10-4-2010.

CASA DE SANTA VITÓRIA

THE MARK CONSISTS OF STANDARD CHARACTERS WITHOUT CLAIM TO ANY PARTICULAR FONT, STYLE, SIZE, OR COLOR.

OWNER OF INTERNATIONAL REGISTRATION 1057692 DATED 10-4-2010, EXPIRES 10-4-2020.

NO CLAIM IS MADE TO THE EXCLUSIVE RIGHT TO USE "SANTA VITORIA", APART FROM THE MARK AS SHOWN.

THE ENGLISH TRANSLATION OF "CASA DE SANTA VITORIA" IN THE MARK IS "SAINT VICTORIA'S HOUSE". FOR WINES (U.S. CLS. 47 AND 49).

AMY HELLA, EXAMINING ATTORNEY

SN 79-089,910. FIRST CAPE LIMITED, UNITED KINGDOM, FILED 11-1-2010.

FirstCape

THE MARK CONSISTS OF STANDARD CHARACTERS WITHOUT CLAIM TO ANY PARTICULAR FONT, STYLE, SIZE, OR COLOR.

OWNER OF INTERNATIONAL REGISTRATION 1032980 DATED 3-3-2010, EXPIRES 3-3-2020.

FOR WINES; WINE-BASED SPIRITS AND LIQUEURS; LOW-ALCOHOL BEVERAGES, NAMELY, LOW-ALCOHOL WINES AND LOW-ALCOHOL WINE-BASED SPIRITS AND LIQUEURS (U.S. CLS. 47 AND 49).

INGRID C. EULIN, EXAMINING ATTORNEY

SN 79-090,997. CHAMPAGNE LOUIS ROEDERER (CLR), F-51100 REIMS, FRANCE, FILED 9-8-2010.



PRIORITY DATE OF 3-30-2010 IS CLAIMED. OWNER OF INTERNATIONAL REGISTRATION 1061088 DATED 9-8-2010, EXPIRES 9-8-2020.

OWNER OF U.S. REG. NO. 3,643,757.

NO CLAIM IS MADE TO THE EXCLUSIVE RIGHT TO USE "CHAMPAGNE", "CHAMPAGNE A REIMS FRANCE", "A REIMS", "ALC. 12% BY VOL", "PRODUCT OF FRANCE-REIMS," AND "750 ML BRUT", APART FROM THE MARK AS SHOWN.

THE COLOR(S) BLACK, WHITE, SILVER AND DARK GREY IS/ARE CLAIMED AS A FEATURE OF THE MARK.

THE MARK CONSISTS OF A LABEL AND A NECK LABEL WITH A PREDOMINANTLY BLACK BACK-

CLASS 33—(Continued).

GROUND IN A COMBINATION OF A PATTERN OF SILVER AND WHITE. THE NECK LABEL CONSISTS OF A CENTER MEDALLION AND TWO BRANCHES. THE CENTER MEDALLION IS IN WHITE AND CONTAINS CONCENTRIC CIRCLES AND AN UPSIDE DOWN TRIANGLE IN BLACK. THE CIRCLES ARE IN BLACK AND SILVER AND CONTAIN THE WORDS "CHAMPAGNE THEOPHILE A REIMS FRANCE" AND THE INTERTWINED LETTERS "T" AND "C" AND ARE ALL IN SILVER. THE WORDS "CHAMPAGNE THEOPHILE" ARE ABOVE AND BELOW THE OUTER CIRCLE IN BLACK. THE TWO BRANCHES ARE IN BLACK AND EACH CONTAINS THE WORD "THEOPHILE" IN WHITE. TO THE FAR RIGHT OF ONE OF THE BRANCHES APPEARS AN OVAL IN BLACK AND IT CONTAINS THE WORDS "CHAMPAGNE THEOPHILE" IN WHITE WITH THE INTERTWINED LETTERS "T" AND "C" IN DARK GREY. BELOW APPEARS A RECTANGULAR LABEL IN BLACK WITH WHITE AND SILVER STRIPES. THE WORDING "CHAMPAGNE" APPEARS AT THE TOP IN SILVER, THE WORDS "THEOPHILE" AND "A REIMS" APPEARS IN THE MIDDLE IN BLACK AND SILVER AND THE WORDING "ALC. 12% BY VOL", "PRODUCT OF FRANCE-REIMS, NM-291-005", AND "750 ML BRUT" ALL APPEARS BELOW IN DARK GREY AND WHITE.

THE ENGLISH TRANSLATION OF "A REIMS" IN THE MARK IS "IN REIMS".

FOR FRENCH WINES, NAMELY, PROTECTED APPELLATION OF ORIGIN WINES FROM CHAMPAGNE (U.S. CLS. 47 AND 49).

SANI KHOURI, EXAMINING ATTORNEY

SN 79-092,414. STEPHEN ROCHE, HARRINGTON, AUSTRALIA, FILED 12-15-2010.

FUKOV

THE MARK CONSISTS OF STANDARD CHARACTERS WITHOUT CLAIM TO ANY PARTICULAR FONT, STYLE, SIZE, OR COLOR.

OWNER OF INTERNATIONAL REGISTRATION 1064686 DATED 12-15-2010, EXPIRES 12-15-2020.

FOR ALCOHOLIC BEVERAGES EXCEPT BEERS; ALCOHOLIC BEVERAGES CONTAINING MORE THAN 1.15 OF ALCOHOL BY VOLUME EXCEPT BEERS; ALCOHOLIC BEVERAGES CONTAINING FRUIT; DISTILLED ALCOHOLIC BEVERAGES; LIQUORS FOR ALCOHOLIC BEVERAGES; PRE-MIXED ALCOHOLIC BEVERAGES EXCEPT BEERS; PREPARATIONS FOR MAKING ALCOHOLIC BEVERAGES, NAMELY, SYRUPS FOR MAKING NON-ALCOHOLIC BEVERAGES EXCEPT BEERS (U.S. CLS. 47 AND 49).

JANET LEE, EXAMINING ATTORNEY

SN 79-097,838. GALASSO ETTORE, ITALY, FILED 4-11-2011.

TANTO

THE MARK CONSISTS OF STANDARD CHARACTERS WITHOUT CLAIM TO ANY PARTICULAR FONT, STYLE, SIZE, OR COLOR.

PRIORITY DATE OF 1-26-2011 IS CLAIMED.

OWNER OF INTERNATIONAL REGISTRATION 1078539 DATED 4-11-2011, EXPIRES 4-11-2021.

THE ENGLISH TRANSLATION OF THE FOREIGN WORD(S) IN THE MARK IS "MUCH".

FOR ALCOHOLIC BEVERAGES EXCEPT BEERS (U.S. CLS. 47 AND 49).

REBECCA POVARCHUK, EXAMINING ATTORNEY

CLASS 33—(Continued).

SN 85-025,193. MAROON WINERY LLC, DBA MAROON WINES, NAPA, CA. FILED 4-28-2010.

Oakville Bench

THE MARK CONSISTS OF STANDARD CHARACTERS WITHOUT CLAIM TO ANY PARTICULAR FONT, STYLE, SIZE, OR COLOR.

NO CLAIM IS MADE TO THE EXCLUSIVE RIGHT TO USE "OAKVILLE", APART FROM THE MARK AS SHOWN. FOR GRAPE WINE (U.S. CLS. 47 AND 49). BRIAN NEVILLE, EXAMINING ATTORNEY

SN 85-025,199. MAROON WINERY LLC, DBA MAROON WINES, NAPA, CA. FILED 4-28-2010.

Rutherford Bench

THE MARK CONSISTS OF STANDARD CHARACTERS WITHOUT CLAIM TO ANY PARTICULAR FONT, STYLE, SIZE, OR COLOR.

NO CLAIM IS MADE TO THE EXCLUSIVE RIGHT TO USE "RUTHERFORD", APART FROM THE MARK AS SHOWN.

FOR GRAPE WINE (U.S. CLS. 47 AND 49). BRIAN NEVILLE, EXAMINING ATTORNEY

SN 85-058,652. PAGO DE LUNA, S.L., VALENCIA, SPAIN, FILED 6-9-2010.

DEHESA DE LUNA

PRIORITY CLAIMED UNDER SEC. 44(D) ON ERPNTM CMNTY TM OFC APPLICATION NO. 008779101, FILED 12-23-2009, REG. NO. 008779101, DATED 5-21-2010, EXPIRES 12-23-2019.

THE MARK CONSISTS OF THE WORDING "DEHESA DE" ABOVE THE WORDING "LUNA".

THE ENGLISH TRANSLATION OF "DEHESA DE LUNA" IN THE MARK IS "MEADOW OF THE MOON".

FOR ALCOHOLIC BEVERAGES EXCEPT BEERS (U.S. CLS. 47 AND 49).

MICHAEL ENGEL, EXAMINING ATTORNEY

CLASS 33—(Continued).

SN 85-109,916. ANTMOORE WINEWORKS LTD, MARLBOROUGH, NEW ZEALAND, FILED 8-18-2010.

kiki

THE MARK CONSISTS OF STANDARD CHARACTERS WITHOUT CLAIM TO ANY PARTICULAR FONT, STYLE, SIZE, OR COLOR.

PRIORITY CLAIMED UNDER SEC. 44(D) ON NEW ZEALAND APPLICATION NO. 685326, FILED 8-5-2010, REG. NO. 828359, DATED 3-8-2011, EXPIRES 8-5-2017.

FOR RED WINE; SPARKLING WINES; WHITE WINE; WINES AND SPARKLING WINES (U.S. CLS. 47 AND 49). JEFF DEFORD, EXAMINING ATTORNEY

SN 85-110,090. BODEGAS CASADO MORALES, ALAVA, SPAIN, FILED 8-18-2010.



OWNER OF ERPNTM CMNTY TM OFC REG. NO. 7332638, DATED 5-27-2009, EXPIRES 10-21-2018.

THE NAME(S), PORTRAIT(S), AND/OR SIGNATURE(S) SHOWN IN THE MARK DOES NOT IDENTIFY A PARTICULAR LIVING INDIVIDUAL.

THE MARK CONSISTS OF THE WORDS "CASADO MORALES" IN STYLIZED SCRIPT SURROUNDED BY AN IRREGULAR SINUSOIDAL LINE.

THE ENGLISH TRANSLATION OF "CASADO" IN THE MARK IS "MARRIED".

FOR WINES (U.S. CLS. 47 AND 49).

FIRST USE 5-17-1994; IN COMMERCE 5-22-2009.

AISHA SALEM, EXAMINING ATTORNEY

CLASS 33—(Continued).

SN 85-116,988. REICHEL VINEYARD, HEALDSBURG, CA.
FILED 8-26-2010.

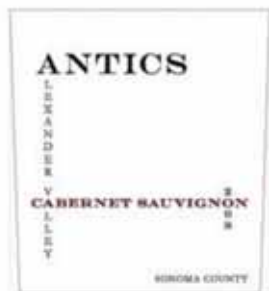

NO CLAIM IS MADE TO THE EXCLUSIVE RIGHT TO USE "ALEXANDER VALLEY", "2008", "CABERNET SAUVIGNON", OR "SONOMA COUNTY", APART FROM THE MARK AS SHOWN.

THE COLOR(S) BLACK, RED AND GRAY IS/ARE CLAIMED AS A FEATURE OF THE MARK.

THE MARK CONSISTS OF A GRAY BACKGROUND WHICH CONTAIN THE WORDS "ANTICS" IN BLACK, "ALEXANDER VALLEY" IN BLACK AND "SONOMA COUNTY" IN BLACK, "CABERNET SAUVIGNON" IN RED, AND THE NUMBERS "2", "0", & "8" IN BLACK. THE MARK ARRANGES THE WORDS AND NUMBERS AS IF ON A CROSSWORD PUZZLE WITH THE WORDS "CABERNET SAUVIGNON" & "SONOMA COUNTY" LISTED HORIZONTALLY AND THE WORDS "ALEXANDER VALLEY" AND "2008" LISTED VERTICALLY.

FOR WINES (U.S. CLS. 47 AND 49).
FIRST USE 8-26-2010; IN COMMERCE 12-1-2010.
C. DIONNE CLYBURN, EXAMINING ATTORNEY

CLASS 33—(Continued).

SN 85-159,056. 750 ML, LLC, MILFORD, DE. FILED 10-22-2010.

BUTTERMILK FALLS

THE MARK CONSISTS OF STANDARD CHARACTERS WITHOUT CLAIM TO ANY PARTICULAR FONT, STYLE, SIZE, OR COLOR.

FOR ALCOHOLIC BEVERAGES EXCEPT BEERS (U.S. CLS. 47 AND 49).

KIM MONINGHOFF, EXAMINING ATTORNEY

SN 85-165,420. CRAIG, PETER C., DAVIS, CA. FILED 10-29-2010.

THE CRAIG FAMILY VINEYARD

THE MARK CONSISTS OF STANDARD CHARACTERS WITHOUT CLAIM TO ANY PARTICULAR FONT, STYLE, SIZE, OR COLOR.

NO CLAIM IS MADE TO THE EXCLUSIVE RIGHT TO USE "FAMILY VINEYARD", APART FROM THE MARK AS SHOWN.

FOR ALCOHOLIC BEVERAGES, NAMELY, WINES (U.S. CLS. 47 AND 49).

CHRISTINA SOBRAL, EXAMINING ATTORNEY

SN 85-128,957. KIMBERLY PFENDLER AS TRUSTEE OF THE KIMBERLY PFENDLER MARITAL TRUST CREATED UNDER THE PETER G. PFENDLER TRUST, DATED JUNE 15, 2007, PETALUMA, CA. FILED 9-14-2010.

PFENDLER

THE MARK CONSISTS OF STANDARD CHARACTERS WITHOUT CLAIM TO ANY PARTICULAR FONT, STYLE, SIZE, OR COLOR.

OWNER OF U.S. REG. NO. 2,984,303.
SEC. 2(F).

FOR WINE (U.S. CLS. 47 AND 49).

FIRST USE 12-31-2008, THE MARK WAS FIRST USED ANYWHERE IN A DIFFERENT FORM OTHER THAN THAT SOUGHT TO BE REGISTERED AT LEAST AS EARLY AS 03/17/2003.; IN COMMERCE 12-31-2008, THE MARK WAS FIRST USED IN COMMERCE IN A DIFFERENT FORM OTHER THAN THAT SOUGHT TO BE REGISTERED AT LEAST AS EARLY AS 03/17/2003..

AISHA CLARKE, EXAMINING ATTORNEY

SN 85-194,244. DESTILADORA SAN NICOLAS, S.A. DE C.V., ARANDAS, JALISCO, MEXICO, FILED 12-9-2010.



THE STIPPLING IS A FEATURE OF THE MARK AND DOES NOT INDICATE COLOR.

THE MARK CONSISTS OF A ROOSTER WITH ITS WINGS EXPANDED.

FOR TEQUILA (U.S. CLS. 47 AND 49).

JOHN E. MICHOS, EXAMINING ATTORNEY

CLASS 33—(Continued).

SN 85-230,250. HUDSON FERUS, LLC, SAN ANTONIO, TX.
FILED 1-31-2011.

SLIZZARD

THE MARK CONSISTS OF STANDARD CHARACTERS WITHOUT CLAIM TO ANY PARTICULAR FONT, STYLE, SIZE, OR COLOR.

FOR ALCOHOLIC BEVERAGES, NAMELY, WINE COOLERS (U.S. CLS. 47 AND 49).

NAAKWAMA ANKRAH, EXAMINING ATTORNEY

SN 85-233,938. ASP WINE COMPANY LLC, RUTHERFORD, CA. FILED 2-4-2011.



THE COLOR(S) BLACK, WHITE, RED AND GRAY IS/ ARE CLAIMED AS A FEATURE OF THE MARK.

THE MARK CONSISTS OF A BLACK AND WHITE JELLY JAR THAT IS HALF FULL OF RED WINE. A GRAY-COLORED SHADOW APPEARS AT THE BOTTOM LEFT OF THE MARK.

FOR WINES (U.S. CLS. 47 AND 49).

FIRST USE 2-5-2007; IN COMMERCE 2-5-2007.

ANDREW RHIM, EXAMINING ATTORNEY

SN 85-236,072. DESTILADORA DE AGAVE AZUL, S.A. DE C.V., GUADALAJARA, JALISCO, MEXICO, FILED 2-7-2011.

EL PIAL

THE MARK CONSISTS OF STANDARD CHARACTERS WITHOUT CLAIM TO ANY PARTICULAR FONT, STYLE, SIZE, OR COLOR.

OWNER OF MEXICO REG. NO. 992896, DATED 6-4-2007, EXPIRES 6-4-2017.

THE ENGLISH TRANSLATION OF "EL PIAL" IN THE MARK IS "THE LASSO".

FOR TEQUILA (U.S. CLS. 47 AND 49).

TASNEEM HUSSAIN, EXAMINING ATTORNEY

CLASS 33—(Continued).

SN 85-237,754. TASSEL RIDGE WINERY, LLC, OSKALOOSA, IA. FILED 2-9-2011.

SWEET ROXIE RED

THE MARK CONSISTS OF STANDARD CHARACTERS WITHOUT CLAIM TO ANY PARTICULAR FONT, STYLE, SIZE, OR COLOR.

NO CLAIM IS MADE TO THE EXCLUSIVE RIGHT TO USE "RED", APART FROM THE MARK AS SHOWN.

FOR WINE (U.S. CLS. 47 AND 49).

FIRST USE 2-1-2008; IN COMMERCE 10-6-2008.

ELIZABETH HUGHITT, EXAMINING ATTORNEY

SN 85-238,601. SEVENOAKS LLC., NEWARK, DE. FILED 2-10-2011.

IVANKA

THE MARK CONSISTS OF STANDARD CHARACTERS WITHOUT CLAIM TO ANY PARTICULAR FONT, STYLE, SIZE, OR COLOR.

THE NAME "IVANKA" DOES NOT IDENTIFY A LIVING INDIVIDUAL.

FOR VODKA (U.S. CLS. 47 AND 49).

MICHAEL ENGEL, EXAMINING ATTORNEY

SN 85-241,949. THE LADIES HERMITAGE ASSOCIATION, DBA THE HERMITAGE, HOME OF PRESIDENT ANDREW JACKSON, HERMITAGE, TN. FILED 2-14-2011.

BATTLE OF NEW ORLEANS

THE MARK CONSISTS OF STANDARD CHARACTERS WITHOUT CLAIM TO ANY PARTICULAR FONT, STYLE, SIZE, OR COLOR.

FOR DISTILLED SPIRITS (U.S. CLS. 47 AND 49).

SUZANNE BLANE, EXAMINING ATTORNEY

CLASS 33—(Continued).

SN 85-242,517. FINCA LUNLUNTA S.A., MAIPU, MENDOZA, ARGENTINA, FILED 2-15-2011.



NO CLAIM IS MADE TO THE EXCLUSIVE RIGHT TO USE "FINCA", APART FROM THE MARK AS SHOWN.

THE MARK CONSISTS OF THE WORDS "FINCA LA CHAMIZA" WITH THE WORD "FINCA" SUPERIMPOSED OVER A HORSESHOE AND A SHADED CIRCLE APPEARING BEFORE AND AFTER THE WORD "FINCA".

THE ENGLISH TRANSLATION OF "FINCA LA CHAMIZA" IN THE MARK IS "BRUSHWOOD FARM".

FOR WINE (U.S. CLS. 47 AND 49).

ANDREW LEASER, EXAMINING ATTORNEY

CLASS 33—(Continued).

SN 85-254,609. FRANZ HAAS S.R.L., MONTAGNA (BOLZANO), ITALY, FILED 3-1-2011.



THE MARK CONSISTS OF A DESIGN OF AN ARM HOLDING A HEART TO THE RIGHT OF A DESIGN OF LIPS, WITH A SUN DESIGN POSITIONED IN THE UPPER LEFT-HAND AREA.

FOR WINES AND SPARKLING WINES (U.S. CLS. 47 AND 49).

FIRST USE 0-0-1996; IN COMMERCE 0-0-1996.

KATHERINE STOIDES, EXAMINING ATTORNEY

SN 85-254,598. FRANZ HAAS S.R.L., MONTAGNA (BOLZANO), ITALY, FILED 3-1-2011.



THE MARK CONSISTS OF A DESIGN OF A HAND PRINT WITH A VINE OF GRAPES INTERMINGLED IN THE FINGERS TO THE RIGHT OF A DESIGN OF LIPS, WITH A SUN DESIGN POSITIONED IN THE UPPER LEFT-HAND AREA.

FOR WINES AND SPARKLING WINES (U.S. CLS. 47 AND 49).

FIRST USE 0-0-1996; IN COMMERCE 0-0-1996.

KATHERINE STOIDES, EXAMINING ATTORNEY

SN 85-257,107. GLJR WINE LLC, NAPA, CA. FILED 3-3-2011.

AONAIR WINES

THE MARK CONSISTS OF STANDARD CHARACTERS WITHOUT CLAIM TO ANY PARTICULAR FONT, STYLE, SIZE, OR COLOR.

NO CLAIM IS MADE TO THE EXCLUSIVE RIGHT TO USE "WINES", APART FROM THE MARK AS SHOWN.

THE ENGLISH TRANSLATION OF THE WORD "AONAIR" IN THE MARK IS "ONE MAN".

FOR WINE (U.S. CLS. 47 AND 49).

NELSON SNYDER, EXAMINING ATTORNEY

CLASS 33—(Continued).

SN 85-259,913. TEMPLÁRSKÉ SKLEPY CEJKOVICE, VINÁRSKÉ DRUZSTVO, CEJKOVICE, CZECH REPUBLIC, FILED 3-7-2011.



OWNER OF CZECH REPUBLIC REG. NO. 249359, DATED 11-25-2002, EXPIRES 1-15-2012.

NO CLAIM IS MADE TO THE EXCLUSIVE RIGHT TO USE "WINE CELLARS CEJKOVICE 1248", APART FROM THE MARK AS SHOWN.

THE COLOR(S) RED, WHITE, AND BLACK IS/ARE CLAIMED AS A FEATURE OF THE MARK.

THE MARK CONSISTS OF THE STYLIZED WORDS "TEMPLAR WINE CELLARS CEJKOVICE 1248" SUPERIMPOSED OVER A STYLIZED CROSS. THE LETTERS ARE DEPICTED IN BLACK, THE NUMERALS "1248" ARE DEPICTED IN WHITE, AND THE CROSS IS DEPICTED IN RED.

FOR WINE (U.S. CLS. 47 AND 49).

COURTNEY ALVAREZ, EXAMINING ATTORNEY

SN 85-260,049. GOOD HOPE CONSULTING CC, SEA POINT, SOUTH AFRICA, FILED 3-7-2011.

AMERICAN PIE

THE MARK CONSISTS OF STANDARD CHARACTERS WITHOUT CLAIM TO ANY PARTICULAR FONT, STYLE, SIZE, OR COLOR.

NO CLAIM IS MADE TO THE EXCLUSIVE RIGHT TO USE "AMERICAN", APART FROM THE MARK AS SHOWN.

FOR WINES (U.S. CLS. 47 AND 49).

PAUL F. GAST, EXAMINING ATTORNEY

SN 85-263,185. ADULT BEVERAGE COMPANY, LAS VEGAS, NV. FILED 3-10-2011.

ADULT ORANGE 50/50

THE MARK CONSISTS OF STANDARD CHARACTERS WITHOUT CLAIM TO ANY PARTICULAR FONT, STYLE, SIZE, OR COLOR.

NO CLAIM IS MADE TO THE EXCLUSIVE RIGHT TO USE "ADULT ORANGE", APART FROM THE MARK AS SHOWN.

FOR ALCOHOLIC BEVERAGES, NAMELY, LIQUEURS AND FLAVORED SPIRITS; FROZEN BEVERAGES CONTAINING LIQUOR AND FLAVORED SPIRITS (U.S. CLS. 47 AND 49).

JENNIFER MARTIN, EXAMINING ATTORNEY

CLASS 33—(Continued).

SN 85-263,558. TEQUILA SAUZA, S. DE R.L. DE C.V., JALISCO, MEXICO, FILED 3-10-2011.

HORNITOS

THE MARK CONSISTS OF STANDARD CHARACTERS WITHOUT CLAIM TO ANY PARTICULAR FONT, STYLE, SIZE, OR COLOR.

OWNER OF U.S. REG. NO. 1,057,158.

THE ENGLISH TRANSLATION OF "HORNITOS" IN THE MARK IS "LITTLE OVENS".

FOR ALCOHOLIC BEVERAGES, NAMELY, TEQUILA (U.S. CLS. 47 AND 49).

FIRST USE 6-0-2007; IN COMMERCE 7-0-2007.

STEVEN JACKSON, EXAMINING ATTORNEY

SN 85-267,355. GRANDES VINOS Y VIÑEDOS, S.A., CARINENA, ZARAGOZA, SPAIN, FILED 3-15-2011.

DON VINICO

THE MARK CONSISTS OF STANDARD CHARACTERS WITHOUT CLAIM TO ANY PARTICULAR FONT, STYLE, SIZE, OR COLOR.

THE NAME "DON VINICO" DOES NOT IDENTIFY A LIVING INDIVIDUAL.

FOR RED, WHITE AND ROSÉ WINE (U.S. CLS. 47 AND 49).

JEFFERY COWARD, EXAMINING ATTORNEY

CLASS 33—(Continued).

SN 85-269,732. FAIRWAY GROUP ACQUISITION COMPANY, NEW YORK, NY. FILED 3-17-2011.



OWNER OF U.S. REG. NOS. 3,545,835, 3,641,831 AND OTHERS.

NO CLAIM IS MADE TO THE EXCLUSIVE RIGHT TO USE "WINES & SPIRITS", APART FROM THE MARK AS SHOWN.

THE MARK CONSISTS OF THE REPRESENTATION OF A CORKSCREW, WITH THE WORD "FAIRWAY" UNDERLINED BY A THICK CURVED BAND, ALL INSIDE THE CORKSCREW; UNDERNEATH THE CORKSCREW ARE THE WORDS "WINES & SPIRITS" WITH THE SCREW FROM THE CORKSCREW FORMING THE "I" IN THE WORD "WINES" AND THE FIRST "I" IN THE WORD "SPIRITS". ALL ENCASED IN A SQUARE.

FOR WINE (U.S. CLS. 47 AND 49).
CARYN GLASSER, EXAMINING ATTORNEY

SN 85-270,759. KENEFAKE & CALINI GROUP LLC, OVERLAND PARK, KS. FILED 3-18-2011.

PETITE DERRIERE

THE MARK CONSISTS OF STANDARD CHARACTERS WITHOUT CLAIM TO ANY PARTICULAR FONT, STYLE, SIZE, OR COLOR.

THE ENGLISH TRANSLATION OF THE WORD "PETITE DERRIERE" IN THE MARK IS "LITTLE BEHIND".

FOR WINES AND SPARKLING WINES (U.S. CLS. 47 AND 49).

MARIA-VICTORIA SUAREZ, EXAMINING ATTORNEY

SN 85-271,591. LOST DOG LLC, CHARLESTON, SC. FILED 3-19-2011.

NO CLAIM IS MADE TO THE EXCLUSIVE RIGHT TO USE "WINES", APART FROM THE MARK AS SHOWN.

THE MARK CONSISTS OF THE WORDS "LOST DOG WINES" WITH THE "O" IN "LOST" AND IN "DOG" BEING DEPICTED BY PAW PRINTS.

FOR WINE (U.S. CLS. 47 AND 49).
FIRST USE 4-15-2010; IN COMMERCE 4-15-2010.
JEFFERY COWARD, EXAMINING ATTORNEY

CLASS 33—(Continued).

SN 85-273,336. NOBLE EIGHT CELLARS, LLC, PORTLAND, OR. FILED 3-22-2011.

Noble Eight Cellars

THE MARK CONSISTS OF STANDARD CHARACTERS WITHOUT CLAIM TO ANY PARTICULAR FONT, STYLE, SIZE, OR COLOR.

NO CLAIM IS MADE TO THE EXCLUSIVE RIGHT TO USE "CELLARS", APART FROM THE MARK AS SHOWN. FOR WINE (U.S. CLS. 47 AND 49).

REBECCA EISINGER, EXAMINING ATTORNEY

SN 85-273,966. TIGER JUICE LLC, HARTSVILLE, SC. FILED 3-22-2011.

Carolina Cowboy

THE MARK CONSISTS OF STANDARD CHARACTERS WITHOUT CLAIM TO ANY PARTICULAR FONT, STYLE, SIZE, OR COLOR.

NO CLAIM IS MADE TO THE EXCLUSIVE RIGHT TO USE "CAROLINA", APART FROM THE MARK AS SHOWN. FOR BLENDED SPIRITS; BOURBON; DISTILLED SPIRITS; VODKA; WHISKY (U.S. CLS. 47 AND 49).

JOHN GARTNER, EXAMINING ATTORNEY

SN 85-274,799. LIBERTINE COMPANY, LIMITED, THE VALLEY, ANGUILLA, FILED 3-23-2011.

MARQUIS VODKA

THE MARK CONSISTS OF STANDARD CHARACTERS WITHOUT CLAIM TO ANY PARTICULAR FONT, STYLE, SIZE, OR COLOR.

NO CLAIM IS MADE TO THE EXCLUSIVE RIGHT TO USE "VODKA", APART FROM THE MARK AS SHOWN. FOR VODKA (U.S. CLS. 47 AND 49).

BARBARA A. GOLD, EXAMINING ATTORNEY

CLASS 33—(Continued).

SN 85-275,430. SELECTIVE WINE ESTATES, INC., EAST HANOVER, NJ. FILED 3-24-2011.

MOMMY'S

THE MARK CONSISTS OF STANDARD CHARACTERS WITHOUT CLAIM TO ANY PARTICULAR FONT, STYLE, SIZE, OR COLOR.

OWNER OF U.S. REG. NO. 3,218,976.
FOR WINES (U.S. CLS. 47 AND 49).
DEIRDRE ROBERTSON, EXAMINING ATTORNEY

SN 85-285,891. ROTELLA HOLDINGS LLC, NAPLES, FL. FILED 4-4-2011.

Vitamin V Vodka

THE MARK CONSISTS OF STANDARD CHARACTERS WITHOUT CLAIM TO ANY PARTICULAR FONT, STYLE, SIZE, OR COLOR.

NO CLAIM IS MADE TO THE EXCLUSIVE RIGHT TO USE "VITAMIN" AND "VODKA", APART FROM THE MARK AS SHOWN.

FOR VODKA, NAMELY, VODKA INFUSED WITH ALL NATURAL VITAMINS AND MINERALS, AS WELL AS OTHER NATURAL INGREDIENTS AND FLAVORS (U.S. CLS. 47 AND 49).

BRIDGETT SMITH, EXAMINING ATTORNEY

SN 85-287,361. FINCA LUNLUNTA S.A., MENDOZA, ARGENTINA, FILED 4-6-2011.

FINCA LA CHAMIZA POLO PROFESIONAL

THE MARK CONSISTS OF STANDARD CHARACTERS WITHOUT CLAIM TO ANY PARTICULAR FONT, STYLE, SIZE, OR COLOR.

NO CLAIM IS MADE TO THE EXCLUSIVE RIGHT TO USE "FINCA", APART FROM THE MARK AS SHOWN.

THE ENGLISH TRANSLATION OF "FINCA LA CHAMIZA" AND "PROFESIONAL" IN THE MARK IS "BRUSHWOOD ESTATE" AND "PROFESSIONAL", RESPECTIVELY. FOR WINE (U.S. CLS. 47 AND 49).

ANDREW LEASER, EXAMINING ATTORNEY

CLASS 33—(Continued).

SN 85-287,521. PAGE MILL WINERY, LIVERMORE, CA. FILED 4-6-2011.



Page Mill Winery

NO CLAIM IS MADE TO THE EXCLUSIVE RIGHT TO USE "WINERY", APART FROM THE MARK AS SHOWN.

THE MARK CONSISTS OF THE WORDS "PAGE MILL WINERY" WITH TWO TREES ABOVE THE WORD "PAGE". FOR WINES (U.S. CLS. 47 AND 49).

FIRST USE 5-13-1978; IN COMMERCE 5-29-1981.
THOMAS MANOR, EXAMINING ATTORNEY

SN 85-288,936. SOUTHERN COMFORT PROPERTIES, INC., SAN RAFAEL, CA. FILED 4-7-2011.



OWNER OF U.S. REG. NOS. 317,529, 2,650,502 AND OTHERS.

THE MARK CONSISTS OF A CIRCLE WITHIN A CIRCLE WITH A POINT ON BOTH THE RIGHT AND LEFT SIDE. INSIDE THE CIRCLE IS AN IMAGE OF AN ALLIGATOR'S HEAD. THE WORDS "BEST GET AFTER IT" ARE IN BETWEEN THE ALLIGATOR'S OPEN MOUTH. UNDER THE ALLIGATOR'S MOUTH ARE THE WORDS "SOUTHERN COMFORT". ABOVE THE ALLIGATOR'S HEAD IS A FLEUR-DE-LIS WITH FOUR DOTS ON EITHER SIDE.

FOR DISTILLED SPIRITS (U.S. CLS. 47 AND 49).
SUZANNE BLANE, EXAMINING ATTORNEY

CLASS 33—(Continued).

SN 85-289,154. DOLIUM S.A., MENDOZA, ARGENTINA, FILED 4-7-2011.

MALBON

THE MARK CONSISTS OF STANDARD CHARACTERS WITHOUT CLAIM TO ANY PARTICULAR FONT, STYLE, SIZE, OR COLOR.

FOR WINE (U.S. CLS. 47 AND 49).
TINA MAI, EXAMINING ATTORNEY

SN 85-289,531. M. DRAXTON, INC., WINDSOR, CA. FILED 4-7-2011.

HENRY BRONSON

THE MARK CONSISTS OF STANDARD CHARACTERS WITHOUT CLAIM TO ANY PARTICULAR FONT, STYLE, SIZE, OR COLOR.

THE NAME(S), PORTRAIT(S), AND/OR SIGNATURE(S) SHOWN IN THE MARK DOES NOT IDENTIFY A PARTICULAR LIVING INDIVIDUAL.

FOR WINES (U.S. CLS. 47 AND 49).
FIRST USE 12-1-2010; IN COMMERCE 12-1-2010.
GEORGE LORENZO, EXAMINING ATTORNEY

SN 85-290,544. DROSTDY WINES LIMITED, STELLENBOSCH, SOUTH AFRICA, FILED 4-8-2011.



THE MARK CONSISTS OF AN IMAGE OF A BODY OF WATER SPLIT BY A CURVING LAND MASS ALL UNDERNEATH A HORIZONTAL LINE. THE BROKEN LINES DEPICTED ARE NOT A PART OF THE MARK AND ARE USED TO SHOW THE POSITION OF THE MARK ON A LABEL.

FOR WINES (U.S. CLS. 47 AND 49).
FIRST USE 3-0-2010; IN COMMERCE 3-0-2011.
ALLISON SCHRODY, EXAMINING ATTORNEY

CLASS 33—(Continued).

SN 85-291,146. STAWSKI DISTRIBUTING CO., INC., CHICAGO, IL. FILED 4-10-2011.

STAWSKI KRUPNIK

THE MARK CONSISTS OF STANDARD CHARACTERS WITHOUT CLAIM TO ANY PARTICULAR FONT, STYLE, SIZE, OR COLOR.

OWNER OF U.S. REG. NOS. 3,214,227 AND 3,702,481.
NO CLAIM IS MADE TO THE EXCLUSIVE RIGHT TO USE "KRUPNIK", APART FROM THE MARK AS SHOWN. THE ENGLISH TRANSLATION OF "KRUPNIK" IN THE MARK IS "MEAD".

SEC. 2(F).
FOR ALCOHOLIC BEVERAGES, NAMELY, HONEY LIQUEURS, WINE, AND MEAD (U.S. CLS. 47 AND 49).
FIRST USE 4-7-2006; IN COMMERCE 4-7-2006.
SAMUEL E. SHARPER JR., EXAMINING ATTORNEY

SN 85-291,172. GRAPEVINE ASSOCIATES INC., UNDERWOOD, WA. FILED 4-10-2011.

PUKEKO

THE MARK CONSISTS OF STANDARD CHARACTERS WITHOUT CLAIM TO ANY PARTICULAR FONT, STYLE, SIZE, OR COLOR.

FOR WINES (U.S. CLS. 47 AND 49).
DAVID TAYLOR, EXAMINING ATTORNEY

SN 85-291,184. DAVID KANBAR, NEW YORK, NY. FILED 4-10-2011.

Chesed

THE MARK CONSISTS OF STANDARD CHARACTERS WITHOUT CLAIM TO ANY PARTICULAR FONT, STYLE, SIZE, OR COLOR.

THE ENGLISH TRANSLATION OF "CHESED" IN THE MARK IS "KINDNESS".
FOR WINE (U.S. CLS. 47 AND 49).
JOHN DWYER, EXAMINING ATTORNEY

CLASS 33—(Continued).

SN 85-291,274. MIRABEAU EIRL, COTIGNAC, FRANCE,
FILED 4-11-2011.

Mirabeau

THE MARK CONSISTS OF STANDARD CHARACTERS
WITHOUT CLAIM TO ANY PARTICULAR FONT, STYLE,
SIZE, OR COLOR.

FOR WINE; ALCOHOLIC BEVERAGES EXCEPT
BEERS (U.S. CLS. 47 AND 49).
KATHRYN COWARD, EXAMINING ATTORNEY

SN 85-292,493. 203 WINE WORKS LTD., BEAUMONT, TX.
FILED 4-12-2011.

Tapdance

THE MARK CONSISTS OF STANDARD CHARACTERS
WITHOUT CLAIM TO ANY PARTICULAR FONT, STYLE,
SIZE, OR COLOR.

FOR ALCOHOLIC BEVERAGES, NAMELY, WINE
(U.S. CLS. 47 AND 49).
JAY FLOWERS, EXAMINING ATTORNEY

SN 85-292,988. JOSE DE JESÚS DOMINGUEZ FIGUEROA,
CIUDAD GUZMAN, MEXICO, FILED 4-12-2011.



MONTAÑEZ

THE NAME(S), PORTRAIT(S), AND/OR SIGNATURE(S)
SHOWN IN THE MARK DOES NOT IDENTIFY A PARTI-
CULAR LIVING INDIVIDUAL.

THE COLOR(S) BLACK, ORANGE AND YELLOW IS/ARE
CLAIMED AS A FEATURE OF THE MARK.

THE MARK CONSISTS OF AN HERALDIC SHIELD
ELEMENT THAT INCLUDES AN AGAVE PLANT, THE
SOIL WHERE THE AGAVE IS PLANTED, AND THE SUN-
LIGHT. BELOW THE HERALDIC SHIELD APPEARS THE
WORDING "MONTAÑEZ". THE COLOR BLACK APPEARS
ON THE WORDING "MONTAÑEZ", THE AGAVE PLANT,
THE SOIL, THE SUNLIGHT, AND THE OUTLINE OF THE
HERALDIC SHIELD. THE ORANGE COLOR IS SHOWN IN
THE SOIL WHERE THE AGAVE IS PLANTED. THE COLOR
YELLOW IS SHOWN IN THE SUNLIGHT.

FOR ALCOHOLIC BEVERAGES EXCEPT BEERS (U.S.
CLS. 47 AND 49).

MARK SHINER, EXAMINING ATTORNEY

CLASS 33—(Continued).

SN 85-293,043. BOEKENHOUTSKLOOF WINERY (PROPRI-
ETARY) LIMITED, STELLENBOSCH, W. CAPE PR, SOUTH
AFRICA, FILED 4-12-2011.

PORSELEIN BERG

THE MARK CONSISTS OF STANDARD CHARACTERS
WITHOUT CLAIM TO ANY PARTICULAR FONT, STYLE,
SIZE, OR COLOR.

OWNER OF SOUTH AFRICA REG. NO. 2009/02626,
DATED 2-4-2009, EXPIRES 2-4-2019.

THE ENGLISH TRANSLATION OF "PORSELEIN BERG"
IN THE MARK IS "PORCELAIN HILL/MOUNTAIN".

FOR WINE (U.S. CLS. 47 AND 49).

RONALD MCMORROW, EXAMINING ATTORNEY

SN 85-293,049. BANFI PRODUCTS CORPORATION, OLD
BROOKVILLE, NY. FILED 4-12-2011.

SOGNO TOSCANO

THE MARK CONSISTS OF STANDARD CHARACTERS
WITHOUT CLAIM TO ANY PARTICULAR FONT, STYLE,
SIZE, OR COLOR.

THE ENGLISH TRANSLATION OF "SOGNO TOSCANO"
IN THE MARK IS "TUSCAN DREAM".

FOR WINES (U.S. CLS. 47 AND 49).

JORDAN BAKER, EXAMINING ATTORNEY

SN 85-293,051. BANFI PRODUCTS CORPORATION, OLD
BROOKVILLE, NY. FILED 4-12-2011.

BELLISA

THE MARK CONSISTS OF STANDARD CHARACTERS
WITHOUT CLAIM TO ANY PARTICULAR FONT, STYLE,
SIZE, OR COLOR.

FOR WINES (U.S. CLS. 47 AND 49).

JORDAN BAKER, EXAMINING ATTORNEY

CLASS 33—(Continued).

SN 85-293,248. VAN RUITEN FAMILY WINERY, LLC, LODI, CA. FILED 4-12-2011.

PRIZIN

THE MARK CONSISTS OF STANDARD CHARACTERS WITHOUT CLAIM TO ANY PARTICULAR FONT, STYLE, SIZE, OR COLOR.
FOR WINES (U.S. CLS. 47 AND 49).
JORDAN BAKER, EXAMINING ATTORNEY

CLASS 33—(Continued).

SN 85-293,784. TROY AND SONS, LLC, ASHEVILLE, NC. FILED 4-13-2011.

LOVIN'

THE MARK CONSISTS OF STANDARD CHARACTERS WITHOUT CLAIM TO ANY PARTICULAR FONT, STYLE, SIZE, OR COLOR.
FOR DISTILLED SPIRITS; SPIRITS; SPIRITS AND LIQUEURS (U.S. CLS. 47 AND 49).
CHRIS WELLS, EXAMINING ATTORNEY

SN 85-293,352. CHACEWATER, INC., DBA CHACEWATER WINE COMPANY AND OLIVE MILL, GRASS VALLEY, CA. FILED 4-12-2011.

Chacewater

THE MARK CONSISTS OF STANDARD CHARACTERS WITHOUT CLAIM TO ANY PARTICULAR FONT, STYLE, SIZE, OR COLOR.
FOR GRAPE WINE (U.S. CLS. 47 AND 49).
FIRST USE 1-1-2008; IN COMMERCE 1-1-2008.
STEVEN JACKSON, EXAMINING ATTORNEY

SN 85-293,789. TROY & SONS LLC, ASHEVILLE, NC. FILED 4-13-2011.

CRYIN'

THE MARK CONSISTS OF STANDARD CHARACTERS WITHOUT CLAIM TO ANY PARTICULAR FONT, STYLE, SIZE, OR COLOR.
FOR DISTILLED SPIRITS; POTABLE SPIRITS; SPIRITS; SPIRITS AND LIQUEURS (U.S. CLS. 47 AND 49).
TEJBIR SINGH, EXAMINING ATTORNEY

SN 85-293,420. OBSESSION WINE COMPANY, OAKVILLE, CA. FILED 4-12-2011.

MELLOWOOD VINEYARD

THE MARK CONSISTS OF STANDARD CHARACTERS WITHOUT CLAIM TO ANY PARTICULAR FONT, STYLE, SIZE, OR COLOR.
OWNER OF U.S. REG. NO. 3,149,979.
NO CLAIM IS MADE TO THE EXCLUSIVE RIGHT TO USE "VINEYARD", APART FROM THE MARK AS SHOWN.
FOR WINES (U.S. CLS. 47 AND 49).
FIRST USE 5-5-2009; IN COMMERCE 5-5-2009.
DOMINIC FATHY, EXAMINING ATTORNEY

SN 85-293,790. TROY & SONS LLC, ASHEVILLE, NC. FILED 4-13-2011.

FIGHTIN'

THE MARK CONSISTS OF STANDARD CHARACTERS WITHOUT CLAIM TO ANY PARTICULAR FONT, STYLE, SIZE, OR COLOR.
FOR DISTILLED SPIRITS; POTABLE SPIRITS; SPIRITS; SPIRITS AND LIQUEURS (U.S. CLS. 47 AND 49).
TEJBIR SINGH, EXAMINING ATTORNEY

CLASS 33—(Continued).

SN 85-294,084. TEQUILA QUIOTE, S.A. DE C.V., CP 47755 JALISCO, MEXICO, FILED 4-13-2011.

QUIOTE

THE MARK CONSISTS OF STANDARD CHARACTERS WITHOUT CLAIM TO ANY PARTICULAR FONT, STYLE, SIZE, OR COLOR.

OWNER OF MEXICO REG. NO. 556296, DATED 4-7-1995, EXPIRES 4-7-2015.

FOR TEQUILA (U.S. CLS. 47 AND 49).
LINDA E. BLOHM, EXAMINING ATTORNEY

CLASS 33—(Continued).

SN 85-299,016. PURPLE WINE COMPANY, GRATON, CA. FILED 4-19-2011.

TTYL

THE MARK CONSISTS OF STANDARD CHARACTERS WITHOUT CLAIM TO ANY PARTICULAR FONT, STYLE, SIZE, OR COLOR.

FOR WINE; WINES (U.S. CLS. 47 AND 49).
HEATHER SAPP, EXAMINING ATTORNEY

SN 85-299,022. BOOTLEGGERS HOMEMADE WINE, LLC, GATLINBURG, TN. FILED 4-19-2011.

Put the South in Your Mouth

THE MARK CONSISTS OF STANDARD CHARACTERS WITHOUT CLAIM TO ANY PARTICULAR FONT, STYLE, SIZE, OR COLOR.

FOR APERITIF WINES; APERITIFS WITH A WINE BASE; COOKING WINE; FORTIFIED WINES; FRUIT WINE; GRAPE WINE; HONEY WINE; KITS FOR MAKING WINE; NATURAL SPARKLING WINES; PORT WINES; PREPARED WINE COCKTAILS; RED WINE; RED WINES; ROSE WINE; SPARKLING FRUIT WINE; SPARKLING GRAPE WINE; SPARKLING WINES; STILL WINES; STRAWBERRY WINE; SWEET WINES; TABLE WINES; TONIC SWEET GRAPE WINE CONTAINING EXTRACTS FROM GINSENG AND CONCHONA BARK (NINJIN-KINATETSU WINE); WHITE WINE; WINE; WINE COOLERS; WINE PUNCH; WINE PUNCHES; WINE-BASED BEVERAGE, NAMELY, PIQUETTE; WINE-BASED DRINKS; WINES; WINES AND FORTIFIED WINES; WINES AND LIQUEURS; WINES AND SPARKLING WINES (U.S. CLS. 47 AND 49).

JULIE GUTTADAURO, EXAMINING ATTORNEY

SN 85-295,690. PURPLE WINE PRODUCTION COMPANY, AKA WHEELHOUSE WINE, GRATON, CA. FILED 4-14-2011.

CRYPTIC

THE MARK CONSISTS OF STANDARD CHARACTERS WITHOUT CLAIM TO ANY PARTICULAR FONT, STYLE, SIZE, OR COLOR.

FOR WINE; WINES (U.S. CLS. 47 AND 49).
BILL DAWE, EXAMINING ATTORNEY

SN 85-297,787. BANFI PRODUCTS CORPORATION, OLD BROOKVILLE, NY. FILED 4-18-2011.

VIA ROSA

THE MARK CONSISTS OF STANDARD CHARACTERS WITHOUT CLAIM TO ANY PARTICULAR FONT, STYLE, SIZE, OR COLOR.

THE ENGLISH TRANSLATION OF "VIA ROSA" IN THE MARK IS "ROSE ROAD" OR "ROSE WAY".

FOR WINES (U.S. CLS. 47 AND 49).
JORDAN BAKER, EXAMINING ATTORNEY

SN 85-303,773. CARIBBEAN DISTILLERS, LLC, LAKE ALFRED, FL. FILED 4-25-2011.

Beauty Mix

THE MARK CONSISTS OF STANDARD CHARACTERS WITHOUT CLAIM TO ANY PARTICULAR FONT, STYLE, SIZE, OR COLOR.

NO CLAIM IS MADE TO THE EXCLUSIVE RIGHT TO USE "MIX", APART FROM THE MARK AS SHOWN.

FOR LIQUOR (U.S. CLS. 47 AND 49).
TOBY BULLOFF, EXAMINING ATTORNEY

CLASS 33—(Continued).

SN 85-305,361. HARLAN ESTATE WINERY, INC., OAKVILLE, CA. FILED 4-26-2011.

PRINCE

THE MARK CONSISTS OF STANDARD CHARACTERS WITHOUT CLAIM TO ANY PARTICULAR FONT, STYLE, SIZE, OR COLOR.
FOR WINE (U.S. CLS. 47 AND 49).
JIM RINGLE, EXAMINING ATTORNEY

SN 85-305,908. FIRESTONE & ROBERTSON SPIRITS, LLC, FORT WORTH, TX. FILED 4-27-2011.

BARON TEXAS BLENDED WHISKEY

THE MARK CONSISTS OF STANDARD CHARACTERS WITHOUT CLAIM TO ANY PARTICULAR FONT, STYLE, SIZE, OR COLOR.
NO CLAIM IS MADE TO THE EXCLUSIVE RIGHT TO USE "TEXAS BLENDED WHISKEY", APART FROM THE MARK AS SHOWN.
FOR WHISKEY (U.S. CLS. 47 AND 49).
ANGELA M. MICHELI, EXAMINING ATTORNEY

SN 85-308,263. UNITED STATES DISTILLED PRODUCTS COMPANY, PRINCETON, MN. FILED 4-29-2011.

FOUREVER

THE MARK CONSISTS OF STANDARD CHARACTERS WITHOUT CLAIM TO ANY PARTICULAR FONT, STYLE, SIZE, OR COLOR.
FOR ALCOHOLIC BEVERAGES EXCEPT BEERS (U.S. CLS. 47 AND 49).
GEORGE LORENZO, EXAMINING ATTORNEY

CLASS 33—(Continued).

SN 85-308,381. OSEZ VOUS? INTERNATIONAL SPIRITS, LLC, WILMINGTON, DE. FILED 4-29-2011.

LAS PLACAS

THE MARK CONSISTS OF STANDARD CHARACTERS WITHOUT CLAIM TO ANY PARTICULAR FONT, STYLE, SIZE, OR COLOR.
THE ENGLISH TRANSLATION OF "LAS PLACAS" IN THE MARK IS "THE PLATES".
FOR ALCOHOLIC BEVERAGES EXCEPT BEERS (U.S. CLS. 47 AND 49).
MARK T. MULLEN, EXAMINING ATTORNEY

SN 85-308,530. OSEZ VOUS? INTERNATIONAL SPIRITS, LLC, WILMINGTON, DE. FILED 4-29-2011.

VIM AND VIGOR

THE MARK CONSISTS OF STANDARD CHARACTERS WITHOUT CLAIM TO ANY PARTICULAR FONT, STYLE, SIZE, OR COLOR.
FOR ALCOHOLIC BEVERAGES EXCEPT BEERS (U.S. CLS. 47 AND 49).
MARK T. MULLEN, EXAMINING ATTORNEY

SN 85-309,181. RIO JOE'S BRANDS, INC., VALLEY VILLAGE, CA. FILED 4-30-2011.



THE COLOR(S) GREEN AND WHITE IS/ARE CLAIMED AS A FEATURE OF THE MARK.
THE MARK CONSISTS OF "ROUTE 1" DESIGN IS IN THE SHAPE OF A MINER'S SPADE. IT IS GREEN WITH WHITE BORDER AND THE TEXT "ROUTE 1" IS IN WHITE AS WELL.
FOR WINE (U.S. CLS. 47 AND 49).
JILL PRATER, EXAMINING ATTORNEY

CLASS 33—(Continued).

SN 85-310,431. CATHERINE-ELIZABETH, INC., SEBASTOPOL, CA. FILED 5-2-2011.

SK

THE MARK CONSISTS OF STANDARD CHARACTERS WITHOUT CLAIM TO ANY PARTICULAR FONT, STYLE, SIZE, OR COLOR.

FOR WINE (U.S. CLS. 47 AND 49).
JUDITH HELFMAN, EXAMINING ATTORNEY

SN 85-310,434. CATHERINE-ELIZABETH, INC., SEBASTOPOL, CA. FILED 5-2-2011.

SWK

THE MARK CONSISTS OF STANDARD CHARACTERS WITHOUT CLAIM TO ANY PARTICULAR FONT, STYLE, SIZE, OR COLOR.

FOR WINE (U.S. CLS. 47 AND 49).
JUDITH HELFMAN, EXAMINING ATTORNEY

SN 85-312,134. HBM ENTERPRISES, INC., SANTA CLARA, CA. FILED 5-4-2011.

WASTED

THE MARK CONSISTS OF STANDARD CHARACTERS WITHOUT CLAIM TO ANY PARTICULAR FONT, STYLE, SIZE, OR COLOR.

FOR VODKA (U.S. CLS. 47 AND 49).
JERI J. FICKES, EXAMINING ATTORNEY

SN 85-314,614. JF STROTHMAN DISTILLERY, INC., GRAND JUNCTION, CO. FILED 5-6-2011.

SMOKEY JOES

THE MARK CONSISTS OF STANDARD CHARACTERS WITHOUT CLAIM TO ANY PARTICULAR FONT, STYLE, SIZE, OR COLOR.

FOR DISTILLED SPIRITS (U.S. CLS. 47 AND 49).
MATTHEW PAPPAS, EXAMINING ATTORNEY

CLASS 33—(Continued).

SN 85-316,441. MCKENZIE RIVER CORPORATION, SAN FRANCISCO, CA. FILED 5-10-2011.

ALCOWATER

THE MARK CONSISTS OF STANDARD CHARACTERS WITHOUT CLAIM TO ANY PARTICULAR FONT, STYLE, SIZE, OR COLOR.

FOR ALCOHOLIC BEVERAGE PRODUCED FROM A BREWED MALT BASE WITH NATURAL FLAVORS; DISTILLED SPIRITS; SPIRITS (U.S. CLS. 47 AND 49).
VERNA BETH RIRIE, EXAMINING ATTORNEY

SN 85-316,443. MCKENZIE RIVER CORPORATION, SAN FRANCISCO, CA. FILED 5-10-2011.

ALCO-WATER

THE MARK CONSISTS OF STANDARD CHARACTERS WITHOUT CLAIM TO ANY PARTICULAR FONT, STYLE, SIZE, OR COLOR.

FOR ALCOHOLIC BEVERAGE PRODUCED FROM A BREWED MALT BASE WITH NATURAL FLAVORS; DISTILLED SPIRITS; SPIRITS (U.S. CLS. 47 AND 49).
VERNA BETH RIRIE, EXAMINING ATTORNEY

SN 85-319,857. PURPLE WINE PRODUCTION COMPANY, GRATON, CA. FILED 5-12-2011.

Linen Napkin

THE MARK CONSISTS OF STANDARD CHARACTERS WITHOUT CLAIM TO ANY PARTICULAR FONT, STYLE, SIZE, OR COLOR.

FOR WINE; WINES (U.S. CLS. 47 AND 49).
BILL DAWE, EXAMINING ATTORNEY

CLASS 33—(Continued).

SN 85-321,783. BOSTON BEER CORPORATION, BOSTON, MA. FILED 5-16-2011.

MAD SCATTER

THE MARK CONSISTS OF STANDARD CHARACTERS WITHOUT CLAIM TO ANY PARTICULAR FONT, STYLE, SIZE, OR COLOR.
FOR HARD CIDER (U.S. CLS. 47 AND 49).
LINDA POWELL, EXAMINING ATTORNEY

SN 85-322,762. CONSTELLATION WINES U.S. INC., CANANDAIGUA, NY. FILED 5-17-2011.

SPYGLASS

THE MARK CONSISTS OF STANDARD CHARACTERS WITHOUT CLAIM TO ANY PARTICULAR FONT, STYLE, SIZE, OR COLOR.
OWNER OF U.S. REG. NO. 2,961,314.
FOR WINE (U.S. CLS. 47 AND 49).
KAPIL BHANOT, EXAMINING ATTORNEY

SN 85-326,346. SARGSYAN, HENRIK, LOS ANGELES, CA. FILED 5-20-2011.

RUSSIAN FANTASY

THE MARK CONSISTS OF STANDARD CHARACTERS WITHOUT CLAIM TO ANY PARTICULAR FONT, STYLE, SIZE, OR COLOR.
NO CLAIM IS MADE TO THE EXCLUSIVE RIGHT TO USE "RUSSIAN", APART FROM THE MARK AS SHOWN.
FOR VODKA PRODUCED IN WHOLE OR IN PART IN RUSSIA (U.S. CLS. 47 AND 49).
LEIGH CAROLINE CASE, EXAMINING ATTORNEY

CLASS 33—(Continued).

SN 85-352,776. PURPLE WINE COMPANY, GRATON, CA. FILED 6-22-2011.

The Sophisticate

THE MARK CONSISTS OF STANDARD CHARACTERS WITHOUT CLAIM TO ANY PARTICULAR FONT, STYLE, SIZE, OR COLOR.
FOR WINE (U.S. CLS. 47 AND 49).
FIRST USE 4-6-2002; IN COMMERCE 4-6-2002.
HEATHER SAPP, EXAMINING ATTORNEY

SN 85-352,790. PURPLE WINE COMPANY, GRATON, CA. FILED 6-22-2011.

Four Vines

THE MARK CONSISTS OF STANDARD CHARACTERS WITHOUT CLAIM TO ANY PARTICULAR FONT, STYLE, SIZE, OR COLOR.
NO CLAIM IS MADE TO THE EXCLUSIVE RIGHT TO USE "VINES", APART FROM THE MARK AS SHOWN.
FOR WINE (U.S. CLS. 47 AND 49).
FIRST USE 6-1-1998; IN COMMERCE 6-1-1998.
HEATHER SAPP, EXAMINING ATTORNEY

CLASS 34—SMOKERS' ARTICLES

SN 76-700,738. J.C. NEWMAN CIGAR COMPANY, TAMPA, FL. FILED 12-8-2009.

FACTORY THROWOUTS

THE MARK CONSISTS OF STANDARD CHARACTERS WITHOUT CLAIM TO ANY PARTICULAR FONT, STYLE, SIZE, OR COLOR.
SEC. 2(F).
FOR CIGARS (U.S. CLS. 2, 8, 9 AND 17).
FIRST USE 3-0-2006; IN COMMERCE 3-0-2006.
WARREN L. OLANDRIA, EXAMINING ATTORNEY

CLASS 34—(Continued).

SN 77-878,680. BRITISH AMERICAN TOBACCO (BRANDS) LIMITED, LONDON, UNITED KINGDOM, FILED 11-23-2009.

MÖBI

THE MARK CONSISTS OF STANDARD CHARACTERS WITHOUT CLAIM TO ANY PARTICULAR FONT, STYLE, SIZE, OR COLOR.

PRIORITY CLAIMED UNDER SEC. 44(D) ON ERP N CMNTY TM OFC APPLICATION NO. 8333031, FILED 6-1-2009, REG. NO. 008333031, DATED 12-24-2009, EXPIRES 6-1-2019.

THE WORDING "MÖBI" HAS NO MEANING IN A FOREIGN LANGUAGE.

FOR CIGARETTES; TOBACCO; TOBACCO PRODUCTS, NAMELY, CUT TOBACCO, LEAF TOBACCO, CHEWING TOBACCO, ORAL TOBACCO, SNUFF AND SNUSS; AND MATCHES (U.S. CLS. 2, 8, 9 AND 17).

WENDY GOODMAN, EXAMINING ATTORNEY

SN 79-086,806. MEDI PLUS TEC MEDIZINISCH-TECHNISCHE HANDELSGESELLSCHAFT MBH, FED REP GERMANY, FILED 8-11-2010.

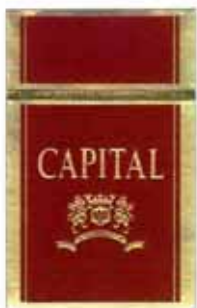

OWNER OF INTERNATIONAL REGISTRATION 0992130 DATED 12-24-2008, EXPIRES 12-24-2018.

THE COLOR(S) RED AND GOLD IS/ARE CLAIMED AS A FEATURE OF THE MARK.

THE MARK CONSISTS OF THE FRONT OF A CIGARETTE BOX WITH AN INTERIOR RECTANGULAR DESIGN AND HORIZONTAL BAND ACROSS THE UPPER PORTION OF THE BOX. THE WORD "CAPITAL" APPEARS REPEATEDLY WITHIN THE HORIZONTAL BAND, IN LARGE LETTERS IN THE CENTER OF THE BOX, AND WITHIN THE CURVED BANNER DESIGN BELOW. A LION INSIGNIA, CROWN AND SHIELD APPEAR BELOW THE WORD "CAPITAL" SHOWN IN THE CENTER OF THE BOX. THE COLOR RED APPEARS IN THE INTERIOR RECTANGULAR DESIGN, IN THE SHIELD DESIGN, AND IN THE WORD "CAPITAL" WITHIN THE CURVED BANNER DESIGN; THE COLOR GOLD APPEARS IN THE EXTERIOR RECTANGULAR OUTLINE AND IN THE TWO VERTICAL LINES FRAMING THE INTERIOR RECTANGULAR DESIGN AND IN THE HORIZONTAL BAND ACROSS THE UPPER PORTION OF THE MARK, IN THE WORD "CAPITAL" SHOWN IN THE CENTER OF THE MARK, AND IN THE LION INSIGNIA, CROWN, SHIELD AND BANNER DESIGNS.

FOR TOBACCO GOODS, IN PARTICULAR CIGARETTES AND FILTER-TIP CIGARETTES; SMOKERS' ARTICLES, NAMELY, ASHTRAYS, CIGARETTE LIGHTERS OF PRECIOUS METAL, CIGARETTE LIGHTERS NOT OF PRECIOUS METAL, CIGARETTE CASES AND CIGARETTE HOLDERS NOT OF PRECIOUS METAL; MATCHES (U.S. CLS. 2, 8, 9 AND 17).

ANDREW RHIM, EXAMINING ATTORNEY

CLASS 34—(Continued).

SN 85-136,093. 13TH FLOOR CIGARS LLC, GILBERT, AZ. FILED 9-22-2010.



THE MARK CONSISTS OF THE WORDING "13FL" ON A CUBE DESIGN.

FOR CIGARS (U.S. CLS. 2, 8, 9 AND 17).
FIRST USE 4-0-2010; IN COMMERCE 4-0-2010.
SARA BENJAMIN, EXAMINING ATTORNEY

SN 85-265,928. OJEDA, RAUL, MIAMI, FL. FILED 3-14-2011.

TAISI

THE MARK CONSISTS OF STANDARD CHARACTERS WITHOUT CLAIM TO ANY PARTICULAR FONT, STYLE, SIZE, OR COLOR.

THE WORDING "TAISI" HAS NO MEANING IN A FOREIGN LANGUAGE.

FOR CIGARS (U.S. CLS. 2, 8, 9 AND 17).
FIRST USE 2-0-2011; IN COMMERCE 2-0-2011.
ANTHONY RINKER, EXAMINING ATTORNEY

SN 85-273,811. LAMBERTZ, KIM, WEST COVINA, CA. FILED 3-22-2011.

Butts Only

THE MARK CONSISTS OF STANDARD CHARACTERS WITHOUT CLAIM TO ANY PARTICULAR FONT, STYLE, SIZE, OR COLOR.

NO CLAIM IS MADE TO THE EXCLUSIVE RIGHT TO USE "BUTTS", APART FROM THE MARK AS SHOWN.

FOR CIGARETTE ASH RECEPTACLES (U.S. CLS. 2, 8, 9 AND 17).

FIRST USE 1-1-2008; IN COMMERCE 1-1-2008.
KAPIL BHANOT, EXAMINING ATTORNEY

CLASS 34—(Continued).

SN 85-275,236. HOGGARD, DANIEL, GLENCOE, CA. FILED 3-24-2011.

CAPTAIN STONE

THE MARK CONSISTS OF STANDARD CHARACTERS WITHOUT CLAIM TO ANY PARTICULAR FONT, STYLE, SIZE, OR COLOR.

THE NAME "CAPTAIN STONE" DOES NOT IDENTIFY A LIVING INDIVIDUAL.

FOR SMOKING PIPES (U.S. CLS. 2, 8, 9 AND 17).

FIRST USE 2-24-2010; IN COMMERCE 2-7-2011.

CHRISTINE COOPER, EXAMINING ATTORNEY

CLASS 34—(Continued).

SN 85-291,658. DORTA AND ORTEGA, P.A., CORAL GABLES, FL. FILED 4-11-2011.



THE MARK CONSISTS OF AN SQUARE WITH "DORTA" IN AN STYLIZED FONT AND BELOW "ORTEGA". THE "&" SEPARATES BOTH NAMES IN THE MIDDLE OF THE SQUARE.

FOR CIGARS (U.S. CLS. 2, 8, 9 AND 17).

GEORGE LORENZO, EXAMINING ATTORNEY

SN 85-290,280. SWEDISH MATCH NORTH EUROPE AB, STOCKHOLM, SWEDEN, FILED 4-8-2011.



SN 85-292,801. BAY HARBOUR VENTURES, LLC, MIAMI BEACH, FL. FILED 4-12-2011.

U CIGS

OWNER OF U.S. REG. NOS. 3,018,074, 3,725,636 AND OTHERS.

NO CLAIM IS MADE TO THE EXCLUSIVE RIGHT TO USE "SWEDISH SNUS", APART FROM THE MARK AS SHOWN.

THE MARK CONSISTS OF A CREST DECORATED WITH LEAVES DISPLAYED ABOVE A CURVED HORIZONTAL RECTANGLE. INSIDE THE RECTANGLE ARE THE WORDS "SWEDISH SNUS" DEPICTED IN THE COLOR WHITE AGAINST A BLACK BACKGROUND ABOVE THE STYLIZED WORD "GENERAL" DEPICTED IN THE COLOR BLACK AGAINST A WHITE BACKGROUND IN THE LOWER PORTION.

THE ENGLISH TRANSLATION OF "SNUS" IN THE MARK IS "SNUFF".

FOR TOBACCO; MATCHES; TOBACCO SUBSTITUTES NOT FOR MEDICAL PURPOSES; SNUFF AND TOBACCO ALTERNATIVES IN THE FORM OF PRODUCTS BASED ON VEGETABLE FIBERS, FOR ORAL USE, NOT FOR CONSUMPTION; SNUFF; TOBACCO FREE SNUFF; HERBAL SNUFF (U.S. CLS. 2, 8, 9 AND 17).

DORITT L. CARROLL, EXAMINING ATTORNEY

THE MARK CONSISTS OF STANDARD CHARACTERS WITHOUT CLAIM TO ANY PARTICULAR FONT, STYLE, SIZE, OR COLOR.

NO CLAIM IS MADE TO THE EXCLUSIVE RIGHT TO USE "CIGS", APART FROM THE MARK AS SHOWN.

FOR ELECTRONIC CIGARETTES; ELECTRONIC CIGARETTE CARTRIDGES; ELECTRONIC CIGARETTE ATOMIZERS; ELECTRONIC CIGARETTE FILTERS; ELECTRONIC CIGARETTE REFILL LIQUIDS; CIGARETTES CONTAINING TOBACCO SUBSTITUTES NOT FOR MEDICAL PURPOSES; ELECTRONIC CIGARETTE LIGHTERS (U.S. CLS. 2, 8, 9 AND 17).

JESSICA A. POWERS, EXAMINING ATTORNEY

CLASS 34—(Continued).

SN 85-300,101. BAY HARBOUR VENTURES, LLC, MIAMI BEACH, FL. FILED 4-20-2011.

AMERICAN VAPOR

THE MARK CONSISTS OF STANDARD CHARACTERS WITHOUT CLAIM TO ANY PARTICULAR FONT, STYLE, SIZE, OR COLOR.

NO CLAIM IS MADE TO THE EXCLUSIVE RIGHT TO USE "AMERICAN", APART FROM THE MARK AS SHOWN. FOR ELECTRONIC CIGARETTES; ELECTRONIC CIGARETTE CARTRIDGES; ELECTRONIC CIGARETTE ATOMIZERS; ELECTRONIC CIGARETTE FILTERS; ELECTRONIC CIGARETTE REFILL LIQUIDS; CIGARETTES CONTAINING TOBACCO SUBSTITUTES NOT FOR MEDICAL PURPOSES; ELECTRONIC CIGARETTE LIGHTERS (U.S. CLS. 2, 8, 9 AND 17).

JESSICA A. POWERS, EXAMINING ATTORNEY

SERVICE MARKS**CLASS 35—ADVERTISING AND BUSINESS**

SN 76-704,445. AOL INC, DULLES, VA. FILED 9-10-2010.

**PROJECT
DEVIL**

THE MARK CONSISTS OF STANDARD CHARACTERS WITHOUT CLAIM TO ANY PARTICULAR FONT, STYLE, SIZE, OR COLOR.

FOR ADVERTISING SERVICES (U.S. CLS. 100, 101 AND 102).

FIRST USE 9-20-2010; IN COMMERCE 9-20-2010.
HELENE LIWINSKI, EXAMINING ATTORNEY

CLASS 35—(Continued).

SN 76-704,692. JDR VENTURES, LLC, BLOOMFIELD HILLS, MI. FILED 9-27-2010.



THE MARK CONSISTS OF THE STYLIZED TERM "IT" ENCLOSED IN A ROUNDED-CORNER SQUARE WITH A CURVED BAND ACROSS THE TOP OF THE SQUARE.

FOR ADVERTISING AND BUSINESS SERVICES, NAMELY, MATCHING MERCHANTS' PRODUCTS WITH CONSUMERS BASED ON TARGET DEMOGRAPHICS DEFINED BY MERCHANTS (U.S. CLS. 100, 101 AND 102).

MYRIAH HABEEB, EXAMINING ATTORNEY

SN 76-705,206. LOGOS DIRECT, LLC, WILMINGTON, NC. FILED 11-3-2010.

LOGOS DIRECT

THE MARK CONSISTS OF STANDARD CHARACTERS WITHOUT CLAIM TO ANY PARTICULAR FONT, STYLE, SIZE, OR COLOR.

NO CLAIM IS MADE TO THE EXCLUSIVE RIGHT TO USE "DIRECT", APART FROM THE MARK AS SHOWN.

SEC. 2(F).

FOR PROMOTING THE GOODS AND SERVICES OF OTHERS BY OPERATING AN ON-LINE SHOPPING MALL WITH LINKS TO RETAIL WEB SITES OF OTHERS (U.S. CLS. 100, 101 AND 102).

JEAN IM, EXAMINING ATTORNEY

SN 76-706,777. BONUS OF AMERICA, INC., MCALESTER, OK. FILED 3-14-2011.

TRAINPRO

THE MARK CONSISTS OF STANDARD CHARACTERS WITHOUT CLAIM TO ANY PARTICULAR FONT, STYLE, SIZE, OR COLOR.

FOR FRANCHISE SERVICES, NAMELY, OFFERING BUSINESS MANAGEMENT ASSISTANCE IN THE ESTABLISHMENT AND OPERATION OF COMMERCIAL CLEANING SERVICE FRANCHISES AND BUSINESSES (U.S. CLS. 100, 101 AND 102).

FIRST USE 1-16-2011; IN COMMERCE 2-23-2011.
TINA L. SNAPP, EXAMINING ATTORNEY

CLASS 35—(Continued).

SN 76-706,778. BONUS OF AMERICA, INC., MCALESTER, OK. FILED 3-14-2011.

MYMARKET

THE MARK CONSISTS OF STANDARD CHARACTERS WITHOUT CLAIM TO ANY PARTICULAR FONT, STYLE, SIZE, OR COLOR.

FOR PROVIDING MARKETING SOLUTIONS FOR COMMERCIAL CLEANING FRANCHISES AND BUSINESSES (U.S. CLS. 100, 101 AND 102).

FIRST USE 1-16-2011; IN COMMERCE 2-23-2011.
TINA L. SNAPP, EXAMINING ATTORNEY

SN 76-706,781. BONUS OF AMERICA, INC., MCALESTER, OK. FILED 3-14-2011.

MASTERFRAN

THE MARK CONSISTS OF STANDARD CHARACTERS WITHOUT CLAIM TO ANY PARTICULAR FONT, STYLE, SIZE, OR COLOR.

FOR FRANCHISING SERVICES, NAMELY, OFFERING BUSINESS MANAGEMENT ASSISTANCE IN THE ESTABLISHMENT, OPERATION AND MANAGEMENT OF COMMERCIAL CLEANING BUSINESSES (U.S. CLS. 100, 101 AND 102).

FIRST USE 1-16-2011; IN COMMERCE 2-23-2011.
TINA L. SNAPP, EXAMINING ATTORNEY

SN 76-706,782. BONUS OF AMERICA, INC., MCALESTER, OK. FILED 3-14-2011.

OPSPRO

THE MARK CONSISTS OF STANDARD CHARACTERS WITHOUT CLAIM TO ANY PARTICULAR FONT, STYLE, SIZE, OR COLOR.

FOR FRANCHISE SERVICES, NAMELY, OFFERING BUSINESS MANAGEMENT ASSISTANCE IN THE ESTABLISHMENT AND OPERATION OF COMMERCIAL CLEANING SERVICE FRANCHISES AND BUSINESSES IN RELATION TO QUALITY CONTROL (U.S. CLS. 100, 101 AND 102).

FIRST USE 1-16-2011; IN COMMERCE 2-23-2011.
TINA L. SNAPP, EXAMINING ATTORNEY

CLASS 35—(Continued).

SN 76-706,784. BONUS OF AMERICA, INC., MCALESTER, OK. FILED 3-14-2011.

OPSCARE

THE MARK CONSISTS OF STANDARD CHARACTERS WITHOUT CLAIM TO ANY PARTICULAR FONT, STYLE, SIZE, OR COLOR.

FOR FRANCHISE SERVICES, NAMELY, OFFERING BUSINESS MANAGEMENT ASSISTANCE IN THE ESTABLISHMENT AND OPERATION OF COMMERCIAL CLEANING SERVICE FRANCHISES AND BUSINESSES IN RELATION TO QUALITY CONTROL (U.S. CLS. 100, 101 AND 102).

FIRST USE 1-16-2011; IN COMMERCE 2-23-2011.
TINA L. SNAPP, EXAMINING ATTORNEY

SN 76-706,785. BONUS OF AMERICA, INC., MCALESTER, OK. FILED 3-14-2011.

UNIFRAN

THE MARK CONSISTS OF STANDARD CHARACTERS WITHOUT CLAIM TO ANY PARTICULAR FONT, STYLE, SIZE, OR COLOR.

FOR FRANCHISING SERVICES, NAMELY, OFFERING BUSINESS MANAGEMENT ASSISTANCE IN THE ESTABLISHMENT, OPERATION AND MANAGEMENT OF COMMERCIAL CLEANING BUSINESSES (U.S. CLS. 100, 101 AND 102).

FIRST USE 1-16-2011; IN COMMERCE 2-23-2011.
TINA L. SNAPP, EXAMINING ATTORNEY

SN 76-706,802. ROGERS, ALEXANDER, BRICK, NJ. FILED 3-14-2011.

PROTEIN FACTORY

THE MARK CONSISTS OF STANDARD CHARACTERS WITHOUT CLAIM TO ANY PARTICULAR FONT, STYLE, SIZE, OR COLOR.

NO CLAIM IS MADE TO THE EXCLUSIVE RIGHT TO USE "PROTEIN", APART FROM THE MARK AS SHOWN.

FOR ONLINE NUTRITIONAL STORE FEATURING SPORTS NUTRITION PRODUCTS, WHICH PRODUCTS INCLUDE UNDER ITS LABEL, WHICH PRODUCTS INCLUDE PROTEIN POWDERS, DIETARY FATS, CARBOHYDRATE POWDERS, INCLUDING WHEY PROTEIN, EGG PROTEIN, AND CASEIN PROTEINS (U.S. CLS. 100, 101 AND 102).

FIRST USE 5-28-1998; IN COMMERCE 5-28-1998.
MARK SPARACINO, EXAMINING ATTORNEY

CLASS 35—(Continued).

SN 76-706,845. SCALES 'N TAILS FRANCHISING, LLC, NORTHGLENN, CO. FILED 3-16-2011.



NO CLAIM IS MADE TO THE EXCLUSIVE RIGHT TO USE "EXOTIC REPTILE PET SHOP", APART FROM THE MARK AS SHOWN.

THE WORDS "SCALES 'N TAILS" APPEAR IN ALL CAPITALIZED LETTERS AND THE WORDS ARE ARCHED OVER THE WORDING "EXOTIC REPTILE PET SHOP" APPEARING IN ALL CAPITAL LETTERS WITH A STRIPED SNAKE CURLED FROM THE BOTTOM OF THE MARK TO THE TOP OF THE MARK, BEHIND AND IN PLACES ABOVE THE WORDS "SCALES 'N TAILS," AND THEN CURLS BACK AROUND AGAIN TO THE BOTTOM OF THE MARK; THE SNAKE'S HEAD IS SEEN FROM THE SIDE WITH ONE EYE VISIBLE AND THE SNAKE'S FORKED TONGUE IS EXTENDED.

FOR RETAIL PET STORES SPECIALIZING IN REPTILES AND OTHER EXOTIC PETS, PET SUPPLIES, AND PET RELATED GOOD (U.S. CLS. 100, 101 AND 102).

FIRST USE 2-17-2011; IN COMMERCE 2-17-2011.
BARBARA BROWN, EXAMINING ATTORNEY

SN 76-706,849. NET RESULTS NINJA, L.L.C., AUSTIN, TX. FILED 3-16-2011.

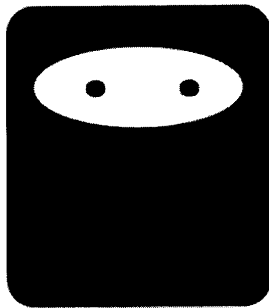

THE MARK CONSISTS OF A FACE WITH TWO EYES INSIDE A RECTANGLE.

FOR ON-LINE ADVERTISING AND MARKETING SERVICES, NAMELY, PROMOTING THE GOODS AND SERVICES OF OTHERS THROUGH SEARCH ENGINE REFERRAL TRAFFIC ANALYSIS AND REPORTING, AND THE PROMOTION, ADVERTISING AND MARKETING OF ON-LINE WEBSITES (U.S. CLS. 100, 101 AND 102).

FIRST USE 9-13-2006; IN COMMERCE 9-13-2006.
B. PARADEWELAI, EXAMINING ATTORNEY

CLASS 35—(Continued).

SN 77-515,351. OMEGA & BEYOND, INC., HONOLULU, HI. FILED 7-6-2008.

Omega Federation

THE MARK CONSISTS OF STANDARD CHARACTERS WITHOUT CLAIM TO ANY PARTICULAR FONT, STYLE, SIZE, OR COLOR.

NO CLAIM IS MADE TO THE EXCLUSIVE RIGHT TO USE "FEDERATION", APART FROM THE MARK AS SHOWN.

FOR BUSINESS CONSULTATION SERVICES (U.S. CLS. 100, 101 AND 102).

FIRST USE 1-1-2008; IN COMMERCE 1-1-2008.
KRISTINA MORRIS, EXAMINING ATTORNEY

SN 77-587,255. TRANS.L SYSTEMS PTY. LTD., SOUTH YARRA, VICTORIA, AUSTRALIA, FILED 10-7-2008.

TRANS.L SYSTEMS

THE MARK CONSISTS OF STANDARD CHARACTERS WITHOUT CLAIM TO ANY PARTICULAR FONT, STYLE, SIZE, OR COLOR.

OWNER OF AUSTRALIA REG. NO. 1233071, DATED 4-3-2008, EXPIRES 4-3-2018.

NO CLAIM IS MADE TO THE EXCLUSIVE RIGHT TO USE "SYSTEMS", APART FROM THE MARK AS SHOWN.

FOR BUSINESS SERVICES, NAMELY, BUSINESS EFFICIENCY AUDITS AND STUDIES, BUSINESS SUPPLY CHAIN EFFICIENCY AUDITS AND STUDIES, BUSINESS PROCESS AUDITING SERVICES, BUSINESS EFFICIENCY EXPERT SERVICES, BUSINESS FEASIBILITY STUDIES, BUSINESS PLANNING SERVICES, MANAGEMENT OF BUSINESS PLAN IMPLEMENTATION, BUSINESS CONSULTANCY AND ADVISORY SERVICES RELATING TO SUPPLY CHAINS, BUSINESS CONSULTANCY AND ADVISORY SERVICES RELATING TO MANUFACTURING, BUSINESS CONSULTANCY AND ADVISORY SERVICES RELATING TO PRODUCT DEVELOPMENT, OUTSOURCING SERVICES, BUSINESS ADVISORY SERVICES FOR MANAGEMENT OF OUTSOURCING; BUSINESS RESEARCH, PROVIDING BUSINESS DATA ANALYSIS AND BUSINESS INFORMATION SERVICES; COMPILATION OF BUSINESS STATISTICS, NAMELY, PROVIDING STATISTICAL INFORMATION RELATING TO SUPPLY CHAINS, MANUFACTURERS, PROCESSORS AND THE PACKAGING INDUSTRY AND PROVIDING STATISTICAL INFORMATION RELATING TO LOGISTICS IN THE FIELD OF MANUFACTURING, PRIMARY PRODUCTION, PACKAGING, SUPERMARKETS AND FOOD SERVICE; BUSINESS CONSULTANCY AND ADVISORY SERVICES, NAMELY, PROVIDING LOGISTICS CONSULTANCY IN THE FIELD OF SUPPLY CHAINS, PACKAGING, STORAGE, TRANSPORTATION, MANUFACTURING, AUTOMATION, PRIMARY INDUSTRY, NAMELY, FRUIT AND VEGETABLE PRODUCTION, MEAT, POULTRY AND FISH PRODUCTION, SECONDARY INDUSTRY, NAMELY, GOODS MANUFACTURING, SUPERMARKETS AND FOOD SERVICE AND PROVIDING LOGISTICS ADVICE IN THE FIELD OF SUPPLY CHAINS, PACKAGING, STORAGE, TRANSPORTATION, MANUFACTURING, AUTOMATION, PRIMARY INDUSTRY, NAMELY, FRUIT AND VEGETABLE PRODUCTION, MEAT, POULTRY AND FISH PRODUCTION, SECONDARY INDUSTRY,

CLASS 35—(Continued).

NAMELY, GOODS MANUFACTURING, SUPERMARKETS AND FOOD SERVICE; BUSINESS MANAGEMENT SERVICES, NAMELY, CHANGE MANAGEMENT, PROJECT MANAGEMENT SERVICES FOR OTHERS IN THE FIELD OF MANUFACTURING, PRIMARY PRODUCTION, PACKAGING, STORAGE, TRANSPORTATION, AUTOMATION, SUPERMARKETS AND FOOD SERVICE; BUSINESS LOGISTICS MANAGEMENT IN THE FIELD OF SUPPLY CHAINS, PACKAGING, STORAGE, TRANSPORTATION, MANUFACTURING, AUTOMATION, PRIMARY INDUSTRY, NAMELY, FRUIT AND VEGETABLE PRODUCTION, MEAT, POULTRY AND FISH PRODUCTION, SECONDARY INDUSTRY, NAMELY, GOODS MANUFACTURING, SUPERMARKETS AND FOOD SERVICE, COMPUTERIZED INVENTORY CONTROL MANAGEMENT, COMPUTERIZED FILE MANAGEMENT, BUSINESS MANAGEMENT OF OUTSOURCING IN THE FIELDS OF PACKAGING, STORAGE, AUTOMATION AND TRANSPORTATION OF PRODUCE, GOODS AND MATERIALS; BUSINESS MANAGEMENT ADVISORY SERVICES, BUSINESS MANAGEMENT AND BUSINESS MANAGEMENT ASSISTANCE TO INDUSTRIAL, AGRICULTURAL OR COMMERCIAL COMPANIES; BUSINESS OPERATION FOR OTHERS; PROCUREMENT SERVICES FOR OTHERS, NAMELY, PROCURING, ON BEHALF OF OTHER BUSINESSES, PACKAGING, REUSABLE PACKAGING, PACKAGING SYSTEMS, CRATES, BINS, MACHINES FOR PACKAGING, MACHINES FOR CLEANING PACKAGING, MACHINES FOR RECYCLING PACKAGING, PACKAGING HANDLING EQUIPMENT, CRATE ERECTORS, CRATE PALLETIZERS, PACKAGING EQUIPMENT, PACKAGING SYSTEMS, LOGISTICS AUTOMATION TECHNOLOGY AND LOGISTICS SOFTWARE; WHOLESALE DISTRIBUTORSHIPS FEATURING PACKAGING, REUSABLE PACKAGING, PACKAGING SYSTEMS, CRATES, BINS, MACHINES FOR PACKAGING, MACHINES FOR CLEANING PACKAGING, MACHINES FOR RECYCLING PACKAGING, PACKAGING HANDLING EQUIPMENT, CRATE ERECTORS, CRATE PALLETIZERS, PACKAGING EQUIPMENT, PACKAGING SYSTEMS, LOGISTICS AUTOMATION TECHNOLOGY AND LOGISTICS SOFTWARE; WHOLESALE ORDERING SERVICES IN THE FIELD OF PACKAGING, REUSABLE PACKAGING, PACKAGING SYSTEMS, CRATES, BINS, MACHINES FOR PACKAGING, MACHINES FOR CLEANING PACKAGING, MACHINES FOR RECYCLING PACKAGING, PACKAGING HANDLING EQUIPMENT, CRATE ERECTORS, CRATE PALLETIZERS, PACKAGING EQUIPMENT, PACKAGING SYSTEMS, LOGISTICS AUTOMATION TECHNOLOGY AND LOGISTICS SOFTWARE; WHOLESALE STORES FEATURING PACKAGING, REUSABLE PACKAGING, PACKAGING SYSTEMS, CRATES, MACHINES FOR PACKAGING, MACHINES FOR CLEANING PACKAGING, MACHINES FOR RECYCLING PACKAGING, PACKAGING HANDLING EQUIPMENT, CRATE ERECTORS, CRATE PALLETIZERS, PACKAGING EQUIPMENT, PACKAGING SYSTEMS, LOGISTICS AUTOMATION TECHNOLOGY AND LOGISTICS SOFTWARE; RETAIL SERVICES, NAMELY, RETAIL STORE SERVICES, RETAIL STORE SERVICES PROVIDED ONLINE OVER A COMPUTER NETWORK, RETAIL MAIL ORDER SERVICES, ALL IN RESPECT OF PACKAGING, REUSABLE PACKAGING, PACKAGING SYSTEMS, CRATES, BINS, MACHINES FOR PACKAGING, MACHINES FOR CLEANING PACKAGING, MACHINES FOR RECYCLING PACKAGING, PACKAGING HANDLING EQUIPMENT, CRATE ERECTORS, CRATE PALLETIZERS, PACKAGING EQUIPMENT, PACKAGING SYSTEMS, LOGISTICS AUTOMATION TECHNOLOGY AND LOGISTICS SOFTWARE; DISTRIBUTORSHIP SERVICES IN THE FIELD OF PACKAGING, REUSABLE PACKAGING, PACKAGING SYSTEMS, CRATES, BINS, MACHINES FOR PACKAGING, MACHINES FOR CLEANING PACKAGING, MACHINES FOR RECYCLING PACKAGING, PACKAGING HANDLING EQUIPMENT, CRATE ERECTORS, CRATE PALLETIZERS, PACKAGING EQUIPMENT, PACKAGING SYSTEMS, LOGISTICS AUTOMATION TECHNOLOGY AND LOGISTICS SOFTWARE; ARRANGING OF BUSINESS EXHIBITIONS FOR ADVERTISING PURPOSES, AND FOR BUSINESS, COMMERCIAL OR TRADE PURPOSES, NAMELY, EXHIBITIONS FEATURING PACKAGING, REUSABLE PACKAGING, PACKAGING SYSTEMS, CRATES, MACHINES FOR PACKAGING, MACHINES

CLASS 35—(Continued).

FOR CLEANING PACKAGING, MACHINES FOR RECYCLING PACKAGING, PACKAGING HANDLING EQUIPMENT, PACKAGING TECHNOLOGY, CRATE ERECTORS, CRATE PALLETIZERS, PACKAGING EQUIPMENT, PACKAGING SYSTEMS, LOGISTICS TECHNOLOGY, RECYCLING TECHNOLOGY, AUTOMATION TECHNOLOGY AND LOGISTICS SOFTWARE; AND EXHIBITIONS RELATING TO LOGISTICS, SUPPLY CHAIN AND PACKAGING PRODUCTS AND SERVICES; ORGANIZATION, OPERATION AND SUPERVISION OF INCENTIVE SCHEMES, NAMELY, CUSTOMER LOYALTY SERVICES FOR COMMERCIAL, PROMOTIONAL AND/OR ADVERTISING PURPOSES; AND PROVIDING BUSINESS INFORMATION AND INFORMATION IN THE FIELD OF LOGISTICS, NAMELY, MANAGING LOGISTICS, REVERSE LOGISTICS, SUPPLY CHAIN SERVICES, SUPPLY CHAIN VISIBILITY AND SYNCHRONIZATION, SUPPLY AND DEMAND FORECASTING AND PRODUCT DISTRIBUTION PROCESSES FOR OTHERS; BUSINESS MANAGEMENT SERVICES, NAMELY, SUPPLY CHAIN LOGISTICS, REVERSE LOGISTICS AND LIQUIDATION OF GOODS OF OTHERS; FREIGHT LOGISTICS MANAGEMENT; TRANSPORTATION LOGISTICS SERVICES, NAMELY, ARRANGING THE TRANSPORTATION OF GOODS FOR OTHERS; TRANSPORTATION LOGISTICS SERVICES, NAMELY, PLANNING AND SCHEDULING SHIPMENTS FOR USERS OF TRANSPORTATION SERVICES; PROVIDING BUSINESS INFORMATION AND INFORMATION IN THE FIELD OF BUSINESS MANAGEMENT, BUSINESS INFORMATION IN THE FIELD OF BUSINESS ORGANIZATION OF FACILITIES AND IMPLEMENTATION OF STRATEGIC BUSINESS PLANS (U.S. CLS. 100, 101 AND 102).

LOURDES AYALA, EXAMINING ATTORNEY

SN 77-681,408. AMERIMARK DIRECT LLC, CLEVELAND, OH. FILED 3-2-2009.

EASYLIVING

THE MARK CONSISTS OF STANDARD CHARACTERS WITHOUT CLAIM TO ANY PARTICULAR FONT, STYLE, SIZE, OR COLOR.

FOR BUYING CLUB SERVICES FOR LEGAL ADVICE AND TAX PREPARATION, ONLINE FITNESS AND NUTRITION PROGRAMS, FITNESS CLUB NETWORKS, PET CARE, AUTOMOTIVE AND EMERGENCY ROADSIDE AUTOMOBILE SERVICES AND EXTENDED WARRANTY PROGRAMS (U.S. CLS. 100, 101 AND 102).

FIRST USE 2-2-2009; IN COMMERCE 2-2-2009.

KATHERINE CHANG, EXAMINING ATTORNEY

CLASS 35—(Continued).

SN 77-706,226. FALLS CHURCH PILATES, LLC, FALLS CHURCH, VA. FILED 4-3-2009.

BeBetter

THE MARK CONSISTS OF STANDARD CHARACTERS WITHOUT CLAIM TO ANY PARTICULAR FONT, STYLE, SIZE, OR COLOR.

FOR RETAIL STORE AND ON-LINE RETAIL STORE SERVICES FEATURING CLOTHING AND HEALTH AND FITNESS PRODUCTS (U.S. CLS. 100, 101 AND 102).
KHANH LE, EXAMINING ATTORNEY

SN 77-777,266. JOHN M. EARLE, HULL, MA. FILED 7-9-2009.



OWNER OF U.S. REG. NOS. 3,110,914, 3,140,914 AND 3,523,569.

THE NAME "JOHNNY CUPCAKE" IN THE MARK DOES NOT IDENTIFY A LIVING INDIVIDUAL.

THE MARK CONSISTS OF A THREE-DIMENSIONAL TRADE DRESS DEPICTING THE INTERIOR OF A RETAIL CLOTHING STORE EVOKING THE THEME OF A BAKERY. WHEN ENTERING THE INTERIOR OF THE STORE, A LARGE COMMERCIAL MIXER APPEARS NEXT TO A WALL PARTITION, A LARGE BAKERY DISPLAY CASE APPEARS AGAINST THE WALL AND ACROSS FROM THE COMMERCIAL MIXER. A BAKERY DISPLAY CASE WITH A RECTANGULAR GLASS FRONT APPEARS NEXT TO THE LARGE BAKERY DISPLAY CASE. THE STYLIZED WORDING "JOHNNY CUPCAKE" WITH A DESIGN OF A CUPCAKE WITH CROSSBONES UNDERNEATH APPEARS TO THE LEFT OF THE WORDING ON THE WALL ABOVE THE DISPLAY CASE WITH RECTANGULAR SHAPED GLASS FRONT. A GLASS FRONT BAKERY DISPLAY CASE APPEARS NEXT TO THE RECTANGULAR SHAPED GLASS FRONT CASE. TWO GLASS FRONT REFRIGERATOR UNITS WITH SIDE BY SIDE DOORS WITH THE UPPER PORTION CONTAINING A DESIGN OF MULTIPLE CUPCAKES WITH TWO LONG ONES CROSSED TOGETHER UNDER EACH OF THE CUPCAKES APPEARS AGAINST THE WALL PARALLEL TO THE WALL CONTAINING THE BAKERY DISPLAY CASES. A NARROW SHELF APPEARS BETWEEN THE TWO GLASS FRONT REFRIGERATOR UNITS. A SMALL TABLE APPEARS ON THE FLOOR ACROSS FROM THE "JOHNNY CUPCAKE" SIGN. THE WALL CONTAINING THE SIGN IS MADE OF BRICKS. THE WALL NEAR THE MIXER IS MADE OF BRICKS.

SEC. 2(F) AS TO "THE INTERIOR OF A RETAIL CLOTHING STORE CONSISTING OF A LARGE COMMERCIAL MIXER APPEARING NEXT TO A WALL PARTITION, A LARGE BAKERY DISPLAY CASE APPEARING AGAINST THE WALL AND ACROSS FROM THE COMMERCIAL MIXER, A BAKERY DISPLAY CASE WITH A RECTANGULAR GLASS FRONT APPEARING NEXT TO THE LARGE

CLASS 35—(Continued).

BAKERY DISPLAY CASE, A GLASS FRONT BAKERY DISPLAY CASE APPEARING NEXT TO THE RECTANGULAR SHAPED GLASS FRONT CASE, TWO GLASS FRONT REFRIGERATOR UNITS WITH SIDE BY SIDE DOORS APPEARING AGAINST THE WALL PARALLEL TO THE WALL CONTAINING THE BAKERY DISPLAY CASES, A NARROW SHELF APPEARING BETWEEN THE TWO GLASS FRONT REFRIGERATOR UNITS, A SMALL TABLE APPEARING ON THE FLOOR, AND THE BRICK WALLS, CEILING, AND FLOORING".

FOR RETAIL STORE SERVICES FEATURING DUFFLE BAGS, PURSES, BACKPACKS, SPORTS BAGS, WALLETS, JEWELRY, NECKLACES, ORNAMENTAL PINS, KEY CHAINS, DOG TAGS, CLOTHING, SHIRTS, POLO SHIRTS, HATS, SHORTS, PANTS, SCARVES, GLOVES, BELTS, JACKETS, SHOES, UNDERGARMENTS, BOXERS, PANTIES, GIFT BOXES, GIFT CARDS, POSTERS, AND PHONE CASES (U.S. CLS. 100, 101 AND 102).

FIRST USE 5-27-2006; IN COMMERCE 5-27-2006.

CIMMERIAN COLEMAN, EXAMINING ATTORNEY

SN 77-818,019. LE, TRAMERICA Q., DBA TRADE EMBASSY, SAN DIEGO, CA. FILED 9-1-2009.

Trade Embassy

THE MARK CONSISTS OF STANDARD CHARACTERS WITHOUT CLAIM TO ANY PARTICULAR FONT, STYLE, SIZE, OR COLOR.

NO CLAIM IS MADE TO THE EXCLUSIVE RIGHT TO USE "TRADE", APART FROM THE MARK AS SHOWN.

FOR PROVIDING A SEARCHABLE ON-LINE ADVERTISING GUIDE FEATURING THE GOODS AND SERVICES OF OTHER ON-LINE VENDORS ON THE INTERNET; PROVIDING ON-LINE VIDEO BUSINESS DIRECTORY; PROVIDING BUSINESS SERVICES, NAMELY, TELEPRESENCE ENVIRONMENTS OF OTHERS; PROVIDING AN ON-LINE ELECTRONIC DATABASE ON GLOBAL COMPUTER NETWORKS FEATURING BUSINESS INFORMATION IN THE FIELDS OF INFORMATION TECHNOLOGY, BUSINESS MANAGEMENT SERVICES INCLUDING PROMOTION OF BRAND IDENTITY, BRANDING STRATEGY, ACCOUNTING, FINANCIAL MANAGEMENT SERVICES, MARKETING, BUSINESS PROJECT MANAGEMENT, AND BUSINESS DEVELOPMENT; PROVIDING ON-LINE ADVERTISING, MARKETING, AND PROMOTIONAL SERVICES; PROVIDING BUSINESS INFORMATION, ON-LINE ADVERTISING ON COMPUTER COMMUNICATION NETWORKS, SERVICES RELATING TO THE ANALYSIS, EVALUATION, CREATION, PROTECTION OF INTELLECTUAL PROPERTY RIGHTS AND BRAND ESTABLISHMENT OF TRADEMARKS, TRADE NAMES AND DOMAIN NAMES; PROJECT MANAGEMENT SERVICES FOR OTHERS IN THE FIELDS OF LANGUAGE TRANSLATION, CUSTOM WRITING, TEXT ADAPTATION, INTERPRETING AND PROOFREADING; FOREIGN AND GLOBAL TRADE CONSULTATION; PROVIDING ONLINE VIRTUAL WORLDS RETAIL STORE SERVICES FEATURING VIRTUAL GOODS, CONDUCTING EVENT PLANNINGS AND TRADE SHOWS IN THE FIELD OF INTELLECTUAL PROPERTY, INTERNATIONAL TRADE, IMPORT, EXPORT, TOURISM, EDUCATION, INFORMATION TECHNOLOGY, HEALTHCARE, BUSINESS MANAGEMENT SERVICES INCLUDING PROMOTION OF BRAND IDENTITY, BRANDING STRATEGY, MARKETING, BUSINESS PROJECT MANAGEMENT, AND BUSINESS DEVELOPMENT, BUSINESS NETWORKING VIA SOCIAL MEDIA NETWORKS AND PROVIDING AN ON-LINE ELECTRONIC DATABASE ON GLOBAL COMPUTER NETWORKS FEATURING BUSINESS INFORMA-

CLASS 35—(Continued).

TION IN THE FIELDS OF INTELLECTUAL PROPERTY, INTERNATIONAL TRADE, IMPORT/EXPORT POLICIES, IMPORT/EXPORT FOREIGN AUTHORITIES, FOREIGN CURRENCIES, INTERNATIONAL IMPORT/EXPORT COMPANIES, INTERNATIONAL TRADE REPRESENTATIVES, INTERNATIONAL TRADE SHOWS, INTERNATIONAL CONVENTION FACILITIES AND INTERNATIONAL TRADE HOUSES, FOREIGN EMBASSIES, FOREIGN TRADE ORGANIZATIONS AND ASSOCIATIONS, FOREIGN TRADE DEVELOPMENT ORGANIZATIONS AND FOREIGN CHAMBERS OF COMMERCE, HEALTHCARE, EDUCATION, INFORMATION TECHNOLOGY AND TOURISM; COMPUTER SERVICES, NAMELY, PROVIDING AN ON-LINE ELECTRONIC DATABASE ON GLOBAL COMPUTER NETWORKS FEATURING BUSINESS INFORMATION IN THE FIELDS OF INTERNATIONAL TRADE, INTERNATIONAL AND NATIONAL CUSTOMS REGULATIONS, INTERNATIONAL TAX REGULATIONS AND INTERNATIONAL SHIPPING REGULATIONS (U.S. CLS. 100, 101 AND 102).

CAROLYN CATALDO, EXAMINING ATTORNEY

SN 77-820,928. AMERICAN INTERNATIONAL RADIO, INC., ROLLING MEADOWS, IL. FILED 9-4-2009.



THE COLOR(S) RED, WHITE, BLACK IS/ARE CLAIMED AS A FEATURE OF THE MARK.

THE MARK CONSISTS OF THE LETTERS "A" "I" "R". THE LETTERS ARE RED. EACH LETTER IS WITHIN A CIRCLE. THE CIRCLE LINING IS BLACK. EACH CIRCLE IS WITHIN A CIRCLE. THE INSIDE OF THE CIRCLE IS WHITE. UNDER THE LETTERS "A" "I" "R", IS THE PHRASE "COMMUNICATION SOLUTIONS WHEN IT MATTERS". THE WORDS OF THIS PHRASE ARE BLACK.

FOR DISTRIBUTORSHIP SERVICES IN THE FIELD OF PROFESSIONAL RADIO COMMUNICATION PRODUCTS, RADIO SYSTEM INTEGRATORS, AND WIRELESS BROADBAND SYSTEMS (U.S. CLS. 100, 101 AND 102).

FIRST USE 1-1-2007; IN COMMERCE 1-1-2007.
MICHAEL ENGEL, EXAMINING ATTORNEY

SN 77-843,079. PFF BRANDS, LLC, DELRAY BEACH, FL. FILED 10-7-2009.



THE MARK CONSISTS OF DESIGN OF A TRUCK DISPOSED THROUGH A RING, SAID RING HAVING A GROOVED OUTER EDGE AND A THINNER GROOVED INNER EDGE AND HAVING MULTIPLE DARKENED

CLASS 35—(Continued).

CIRCLES WITHIN THE INNER AREA OF THE RING VISIBLE AROUND THE TRUCK, WITH THREE WING-LIKE PROJECTIONS EXTENDING FROM THE LEFT SIDE OF THE RING AND THE RIGHT SIDE OF THE RING, WITH A CURVED CIRCULAR BANNER DISPOSED AROUND THE BOTTOM HALF OF THE RING WITH A LINE ALONG THE TOP AND BOTTOM EDGES AND THE WORDS "ON THE ROAD TO A BETTER TOMORROW" ALONG THE MIDDLE PORTION OF THE CURVED BANNER.

FOR TRANSPORTATION LOGISTICS SERVICES, NAMELY, ARRANGING THE TRANSPORTATION OF GOODS FOR OTHERS (U.S. CLS. 100, 101 AND 102).

ROBIN CHOSID, EXAMINING ATTORNEY

SN 77-853,230. PUBLICINSITE WEB ANALYTICS INC., OTTOWA, ONTARIO, CANADA, FILED 10-20-2009.

CROWDSENSE

THE MARK CONSISTS OF STANDARD CHARACTERS WITHOUT CLAIM TO ANY PARTICULAR FONT, STYLE, SIZE, OR COLOR.

PRIORITY CLAIMED UNDER SEC. 44(D) ON CANADA APPLICATION NO. 1435155, FILED 4-20-2009, REG. NO. TMA769,154, DATED 6-8-2010, EXPIRES 6-8-2025.

FOR MARKETING ANALYSIS SERVICES, NAMELY, CONDUCTING CONSUMER TRACKING BEHAVIOR RESEARCH AND CONSUMER TREND ANALYSIS THROUGH THE USE OF WEB-BASED ANALYTICAL TOOLS IN THE FIELD OF WEBSITE AND MARKET ANALYSIS, MARKETING DATA AND STATISTICS RELATING TO SEARCH ENGINE OPTIMIZATION AND MARKETING (U.S. CLS. 100, 101 AND 102).

JULIE GUTTADAURO, EXAMINING ATTORNEY

SN 77-898,939. FOODIE REGISTRY, LLC, CHICAGO, IL. FILED 12-22-2009.



NO CLAIM IS MADE TO THE EXCLUSIVE RIGHT TO USE "FOODIE REGISTRY", APART FROM THE MARK AS SHOWN.

THE MARK CONSISTS OF RECTANGULAR SHIELD WITH WORDS "FOODIE REGISTRY" BELOW CROSSED FORK AND KNIFE WITH THREE DOTS ON EITHER SIDE.

FOR ADVERTISING SERVICES, NAMELY, PROMOTING THE GIFT CARDS OF OTHERS; GIFT REGISTRY SERVICES; ISSUING GIFT CERTIFICATES WHICH MAY THEN BE REDEEMED FOR GOODS OR SERVICES; PROMOTIONAL SERVICES, NAMELY, PROMOTING THE GOODS OF OTHERS BY MEANS OF PROVIDING ONLINE GIFT CARDS (U.S. CLS. 100, 101 AND 102).

FIRST USE 9-15-2009; IN COMMERCE 9-15-2009.
STEPHANIE ALI, EXAMINING ATTORNEY

CLASS 35—(Continued).

SN 77-915,285. IDEXCEL, INC., HERNDON, VA. FILED 1-19-2010.

IDEXCEL

THE MARK CONSISTS OF STANDARD CHARACTERS WITHOUT CLAIM TO ANY PARTICULAR FONT, STYLE, SIZE, OR COLOR.

THE WORDING "IDEXCEL" HAS NO MEANING IN A FOREIGN LANGUAGE.

FOR BUSINESS CONSULTATION; BUSINESS CONSULTATION IN THE FIELD OF UTILITIES, HEALTH CARE, TRANSPORTATION, RETAIL AND DISTRIBUTION, TELECOMMUNICATIONS, INSURANCE, FINANCIAL SERVICES, BANKING, MANUFACTURING AND PROCESS INDUSTRIES, AND ELECTRONIC COMMERCE, INFORMATION TECHNOLOGY, SYSTEMS MANAGEMENT AND INTEGRATION, PRODUCT DEVELOPMENT AND SUPPORT, SOFTWARE ENGINEERING, INFORMATION TECHNOLOGY OUTSOURCING SERVICES, SYSTEMS MANAGEMENT AND INTEGRATION, PRODUCT DEVELOPMENT AND SUPPORT; BUSINESS CONSULTATION SERVICES; BUSINESS CONSULTATION SERVICES, NAMELY, BUSINESS PROCESS IMPROVEMENT AND ENTERPRISE ARCHITECTURE DESIGN; COMPILING OF INFORMATION INTO COMPUTER DATABASES; COMPUTERIZED DATABASE MANAGEMENT; DATABASE MANAGEMENT; MANAGEMENT AND COMPILATION OF COMPUTERISED DATABASES (U.S. CLS. 100, 101 AND 102).

FIRST USE 1-4-2010; IN COMMERCE 1-4-2010.
MYRIAH HABEEB, EXAMINING ATTORNEY

SN 77-927,441. JULIUS KEDVESSY, OSHAWA, ONTARIO, CANADA, FILED 2-3-2010.

Game Junkyz

THE MARK CONSISTS OF STANDARD CHARACTERS WITHOUT CLAIM TO ANY PARTICULAR FONT, STYLE, SIZE, OR COLOR.

NO CLAIM IS MADE TO THE EXCLUSIVE RIGHT TO USE "GAME", APART FROM THE MARK AS SHOWN.

FOR RETAIL STORE SERVICES FEATURING VIDEO GAMES, VIDEO GAME SYSTEMS AND VIDEO GAME ITEMS, NAMELY, CONTROLLERS (U.S. CLS. 100, 101 AND 102).

AMY C. KEAN, EXAMINING ATTORNEY

CLASS 35—(Continued).

SN 77-945,758. BAY PARKWAY PRODUCTION, PACIFIC PALISADES, CA. FILED 2-26-2010.

ARCHITECTURE MAN

THE MARK CONSISTS OF STANDARD CHARACTERS WITHOUT CLAIM TO ANY PARTICULAR FONT, STYLE, SIZE, OR COLOR.

NO CLAIM IS MADE TO THE EXCLUSIVE RIGHT TO USE "ARCHITECTURE", APART FROM THE MARK AS SHOWN.

FOR PUBLICITY SERVICES (U.S. CLS. 100, 101 AND 102).

JOHN DWYER, EXAMINING ATTORNEY

SN 77-950,786. BIEBER, CRAIG J., LEOLA, SD. FILED 3-4-2010.

BIEBER

THE MARK CONSISTS OF STANDARD CHARACTERS WITHOUT CLAIM TO ANY PARTICULAR FONT, STYLE, SIZE, OR COLOR.

OWNER OF U.S. REG. NOS. 3,953,332, 3,953,337 AND 3,953,351.

SEC. 2(F).

FOR ARRANGING AND CONDUCTING SALES FOR OTHERS OF LIVESTOCK AND REGISTERED AND COMMERCIAL CATTLE; LIVESTOCK AUCTION SERVICES; BUSINESS CONSULTING SERVICES IN THE FIELD OF ANIMAL BREEDING AND ANIMAL GENETICS (U.S. CLS. 100, 101 AND 102).

FIRST USE 0-0-2006; IN COMMERCE 0-0-2006.

LIEF MARTIN, EXAMINING ATTORNEY

CLASS 35—(Continued).

SN 77-966,883. SCREENVISION HOLDINGS, INC., NEW YORK, NY. FILED 3-24-2010.



OWNER OF U.S. REG. NOS. 2,635,252, 2,706,601 AND 2,857,983.

NO CLAIM IS MADE TO THE EXCLUSIVE RIGHT TO USE "PREMIERE SERIES", APART FROM THE MARK AS SHOWN.

THE COLOR(S) RED, BLACK AND GRAY IS/ARE CLAIMED AS A FEATURE OF THE MARK.

THE MARK CONSISTS OF INTERSECTING WAVES OF SCROLLS OVERARCHING TO THE LEFT AND RIGHT OF FIVE LINES OF TEXT, STARTING AT THE BEGINNING OF LINE 2 ON THE LEFT, AND AT THE END OF LINE 2 ON THE RIGHT, AND CURLING UNDER LINE 4 OF THE TEXT. THERE IS A SIX POINTED STAR DESIGN TO THE LEFT OF THE WORD "SCREENVISION". THE SCROLL DESIGN IS IN GRAY, THE TEXT "ALL ACCESS" IS IN RED, AND "SCREENVISION" AND "RED CARPET PREMIERE SERIES" AND THE STAR DESIGN ARE IN BLACK.

FOR ADVERTISING AND MARKETING SERVICES, NAMELY, PROMOTING THE GOODS AND SERVICES OF OTHERS BY ARRANGING FOR SPONSORS TO AFFILIATE THEIR GOODS AND SERVICES WITH MOVIE PREMIERES AND AFTER-PARTIES (U.S. CLS. 100, 101 AND 102).

FIRST USE 1-25-2010; IN COMMERCE 1-25-2010.
ANNE FARRELL, EXAMINING ATTORNEY

SN 77-980,644. KILZER, THOMAS, LOS ANGELES, CA. FILED 1-5-2010.

HUSH LITTLE BABY

THE MARK CONSISTS OF STANDARD CHARACTERS WITHOUT CLAIM TO ANY PARTICULAR FONT, STYLE, SIZE, OR COLOR.

OWNER OF U.S. REG. NO. 2,925,164.

FOR ONLINE RETAIL STORE SERVICES FEATURING A VARIETY OF CONSUMER GOODS TO HELP BABIES FALL ASLEEP, BABY WEAR, DIGITAL AUDIO AND VIDEO DISCS FOR PARENTS, BABIES AND CARE-GIVERS, SLEEP-INDUCING TOYS AND PILLOWS, NIGHT LIGHTS, BLANKETS, SWADDLING BLANKETS, BOOKS, SLEEPWEAR, BREAST PUMPS AND KITS, BREAST CARE PRODUCTS, BABY MONITORS, MOBILES, STROLLERS, BABY CARRIERS, SLINGS FOR BABIES, CAR SEATS, BOOSTERS AND HIGH CHAIRS (U.S. CLS. 100, 101 AND 102).

FIRST USE 11-1-2003; IN COMMERCE 11-1-2003.
COLLEEN KEARNEY, EXAMINING ATTORNEY

CLASS 35—(Continued).

SN 78-963,341. PCC LICENSING, INC., CALABASAS, CA. FILED 8-29-2006.

SUZANNE

THE MARK CONSISTS OF STANDARD CHARACTERS WITHOUT CLAIM TO ANY PARTICULAR FONT, STYLE, SIZE, OR COLOR.

OWNER OF U.S. REG. NO. 3,164,724.

FOR SHOP-AT-HOME PARTIES FEATURING COSMETICS AND SKIN CARE PRODUCTS, VITAMINS, FOOD SUPPLEMENTS, DIETARY AND NUTRITIONAL SUPPLEMENTS, FOOD PRODUCTS, JEWELRY, EXERCISE EQUIPMENT, VIDEOS, BOOKS, AND KITCHENWARE; DOOR-TO-DOOR RETAIL MERCHANDISING OF PRODUCTS, DISTRIBUTORSHIP SERVICES, RETAIL STORE SERVICES, RETAIL SERVICES BY DIRECT SOLICITATION BY INDEPENDENT SALES REPRESENTATIVES, TELEPHONE SHOP AT HOME SERVICES, MAIL ORDER CATALOG SERVICES, INTERACTIVE RETAIL STORE SERVICES RENDERED BY MEANS OF A GLOBAL COMPUTER INFORMATION NETWORK, ALL IN THE FIELDS OF COSMETICS AND SKIN CARE PRODUCTS, VITAMINS, FOOD SUPPLEMENTS, DIETARY AND NUTRITIONAL SUPPLEMENTS, FOOD PRODUCTS, JEWELRY, EXERCISE EQUIPMENT, VIDEOS, BOOKS, AND KITCHENWARE; RENDERING TECHNICAL ASSISTANCE IN CONNECTION WITH THE ESTABLISHMENT AND OPERATION OF HOUSE-TO-HOUSE RETAIL MERCHANDISING OF VARIOUS GOODS IN THE FIELDS OF COSMETICS AND SKIN CARE PRODUCTS, VITAMINS, FOOD SUPPLEMENTS, DIETARY AND NUTRITIONAL SUPPLEMENTS, FOOD PRODUCTS, JEWELRY, EXERCISE EQUIPMENT, VIDEOS, BOOKS, AND KITCHENWARE (U.S. CLS. 100, 101 AND 102).

MIDGE BUTLER, EXAMINING ATTORNEY

SN 79-087,070. ITALSERVICES SPA, ITALY, FILED 6-1-2010.

MET
in EUROPE

PRIORITY DATE OF 5-18-2010 IS CLAIMED.

OWNER OF INTERNATIONAL REGISTRATION 1050381 DATED 6-1-2010, EXPIRES 6-1-2020.

FOR RETAIL AND WHOLESALE STORE SERVICES ON BEHALF OF OTHERS FEATURING CLOTHING, FOOTWEAR, HEADGEAR, BAGS, SUITCASES, BRIEFCASES, BELTS, JEWELRY, PERFUMES; SALES PROMOTION ON BEHALF OF OTHERS; PRODUCT PRESENTATIONS ON MEDIA, NAMELY, RETAIL STORES SERVICES AVAILABLE THROUGH COMPUTER COMMUNICATION AND INTERACTIVE TELEVISION FEATURING CLOTHING, FOOTWEAR, HEADGEAR, BAGS, SUITCASES, BRIEFCASES, BELTS, JEWELRY, PERFUMES; ORGANIZATION OF EXHIBITIONS FOR COMMERCIAL OR ADVERTISING PURPOSES (U.S. CLS. 100, 101 AND 102).

MARILYN IZZI, EXAMINING ATTORNEY

CLASS 35—(Continued).

SN 79-091,625. OTKRYTOE AKTSIONERNOE OBSHCHESTVO "ASTON PRODUKTY PITANIA I PISHCHEVYE INGREDIENTY", RUSSIAN FED., FILED 10-14-2010.

MAGIC VALLEY

OWNER OF INTERNATIONAL REGISTRATION 1062517 DATED 10-14-2010, EXPIRES 10-14-2020.

THE MARK CONSISTS OF "MAGIC VALLEY" IN CAPITAL BLOCK LETTERS.

FOR AUCTIONEERING; CONDUCTING MARKETING STUDIES; COMMERCIAL INFORMATION AGENCIES; IMPORT-EXPORT AGENCIES IN THE FIELD OF EDIBLE OILS; DEMONSTRATION OF PRODUCTS, NAMELY, EDIBLE OILS; ADVERTISING; DISSEMINATION OF ADVERTISING MATTER; ORGANIZATION OF EXHIBITIONS FOR COMMERCIAL OR ADVERTISING PURPOSES; COMMERCIAL AND INDUSTRIAL MANAGEMENT ASSISTANCE; SALES PROMOTION FOR OTHERS (U.S. CLS. 100, 101 AND 102).

CHRISTOPHER BUONGIORNO, EXAMINING ATTORNEY

SN 79-092,851. DIGITALMR INTERNATIONAL LIMITED, CYPRUS, FILED 1-12-2011.

Digital:MR

PRIORITY DATE OF 8-11-2010 IS CLAIMED. OWNER OF INTERNATIONAL REGISTRATION 1065883 DATED 1-12-2011, EXPIRES 1-12-2021.

THE COLOR(S) DARK BLUE, LIGHT BLUE AND BLACK IS/ARE CLAIMED AS A FEATURE OF THE MARK.

THE MARK CONSISTS OF THE WORD "DIGITAL" IN DARK BLUE. CONNECTED TO THE RIGHT ARE THREE SHADED CIRCLES IN BLACK VERTICALLY LINED, AND CONNECTED TO THE RIGHT IS THE TERM "MR" IN LIGHT BLUE.

FOR MARKET RESEARCH SERVICES, BUSINESS INFORMATION AND CONSULTANCY SERVICES (U.S. CLS. 100, 101 AND 102).

MICHAEL WIENER, EXAMINING ATTORNEY

SN 79-093,685. LE PAGE ERWAN, FRANCE, AND LE ROUX YANN, FRANCE, FILED 1-5-2011.

matiro

OWNER OF INTERNATIONAL REGISTRATION 1067399 DATED 1-5-2011, EXPIRES 1-5-2021.

THE COLOR(S) BLACK, WHITE AND PURPLE IS/ARE CLAIMED AS A FEATURE OF THE MARK.

THE MARK CONSISTS OF THE WORDS "MATIRO" WITH A TARGET DESIGN FORMING THE LETTER "O". THE LETTERS "MATIR" APPEAR IN BLACK AND THE TARGET DESIGN IS FORMED BY ALTERNATING PURPLE AND WHITE RINGS.

THE WORDING "MATIRO" HAS NO MEANING IN A FOREIGN LANGUAGE.

FOR ON-LINE ADVERTISING ON A COMPUTER NETWORK; TRADING OF ADVERTISING SPACE ON THE INTERNET FOR OTHERS (U.S. CLS. 100, 101 AND 102).

DEBRA LEE, EXAMINING ATTORNEY

CLASS 35—(Continued).

SN 85-013,223. WAGGENER EDSTROM WORLDWIDE, INC., LAKE OSWEGO, OR. FILED 4-13-2010.

WE TWENDZ PRO

THE MARK CONSISTS OF STANDARD CHARACTERS WITHOUT CLAIM TO ANY PARTICULAR FONT, STYLE, SIZE, OR COLOR.

NO CLAIM IS MADE TO THE EXCLUSIVE RIGHT TO USE "PRO", APART FROM THE MARK AS SHOWN.

FOR BUSINESS MONITORING, ANALYTICS, AND CONSULTING SERVICES RELATING TO STRATEGY AND MARKETING, NAMELY, TRACKING ONLINE WEBSITES FEATURING SOCIAL NETWORKING POSTINGS OF ALL KINDS, ONLINE WEBSITES FEATURING TEXT-BASED POSTS AND APPLICATIONS OF OTHERS, PARTICULARLY SPECIALIZING IN THE USE OF ANALYTIC AND STATISTICS MODELS FOR THE UNDERSTANDING OF ONLINE COMMUNICATIONS BY CONSUMERS, ACTIONS BASED ON THOSE COMMUNICATIONS, AND MARKET TRENDS, CONSULTING SERVICES IN THE FIELD OF ONLINE CONSUMER COMMUNICATIONS PERTAINING TO BUSINESSES, NAMELY, CONSULTING IN THE FIELD OF DEVELOPMENT OF MARKETING STRATEGIES, NAMELY, AUDIENCE DEVELOPMENT, MESSAGE DEVELOPMENT, BRAND AWARENESS, CUSTOMER RELATIONS, ONLINE COMMUNITY BUILDING, AND DIGITAL WORD OF MOUTH COMMUNICATIONS (U.S. CLS. 100, 101 AND 102).

FIRST USE 11-17-2009; IN COMMERCE 11-17-2009.

SETH A. RAPPAPORT, EXAMINING ATTORNEY

SN 85-022,121. UTBW, L.L.C., SANTA FE, NM. FILED 4-23-2010.

A TO Z

THE MARK CONSISTS OF STANDARD CHARACTERS WITHOUT CLAIM TO ANY PARTICULAR FONT, STYLE, SIZE, OR COLOR.

FOR RETAIL STORE SERVICES, NAMELY, FEATURING SUNGLASSES, POST CARDS, READING GLASSES, CAMERA FILM, BATTERIES, GREETING CARDS, NYLONS, BOTTLED WATER, SOFT DRINKS, CANDY AND SNACKS, CLOTHING, BAGS, FANNY PACKS, BACK PACKS, TOTE BAGS, HATS, GLOVES, UMBRELLAS, T-SHIRTS, SANDALS, TENNIS SHOES, SOCKS, COLD REMEDIES, SUNSCREEN, DENTAL FLOSS, TOOTH-PASTE, EYE DROPS, SKIN AND HAIR CARE PRODUCTS, NAIL POLISH, MASCARA, LIPSTICK AND PONYTAIL CLIPS, TOYS AND NOVELTY ITEMS FOR KIDS OF ALL AGES, HAMMERS, EXTENSION CORDS, PAPER TOWELS AND LIGHT BULBS (U.S. CLS. 100, 101 AND 102).

WILLIAM ROSSMAN, EXAMINING ATTORNEY

CLASS 35—(Continued).

SN 85-025,285. CHALL, FRED, DBA FRED CHALL MARINE, MUTTONTOWN, NY. FILED 4-28-2010.



NO CLAIM IS MADE TO THE EXCLUSIVE RIGHT TO USE "MARINE", APART FROM THE MARK AS SHOWN. THE NAME "FRED CHALL" IDENTIFIES A LIVING INDIVIDUAL WHOSE CONSENT IS OF RECORD.

THE MARK CONSISTS OF THE WORDING "FCM FRED CHALL MARINE" AND DESIGN. THE LETTERS "F" AND "M" IN THE TERM "FCM" ARE COMPRISED OF LETTERS WITH WAVES AT THE TOP OF EACH LETTER AND THE LETTER "C" IS COMPRISED OF A STYLIZED FISH. THE TERM "FCM" IS ABOVE THE WORDING "FRED CHALL MARINE".

FOR RETAIL OUTLET SERVICES IN THE FIELD OF BOATS AND MARINE ACCESSORIES (U.S. CLS. 100, 101 AND 102).

FIRST USE 4-28-2010; IN COMMERCE 4-28-2010.
DARRYL SPRUILL, EXAMINING ATTORNEY

CLASS 35—(Continued).

SN 85-043,823. IDENTITY BRANDING, INC., GREENSBORO, NC. FILED 5-20-2010.

e-Relationship

THE MARK CONSISTS OF STANDARD CHARACTERS WITHOUT CLAIM TO ANY PARTICULAR FONT, STYLE, SIZE, OR COLOR.

SEC. 2(F).

FOR PROVIDING ADVERTISING SERVICES TO ENABLE FINANCIAL SERVICES SALESPERSONS TO MAINTAIN CONTACT WITH CUSTOMERS AND PROSPECTS BY DISTRIBUTING ADVERTISEMENTS FOR DISPLAY ON THE INTERNET, NAMELY, IN WEBSITES, SOCIAL CONVERSATIONS OVER THE INTERNET, EMAILS, MICROBLOGS, BLOGS, ELECTRONIC MESSAGES, INSTANT MESSAGES, TEXT MESSAGES, MULTIMEDIA MESSAGES, SOCIAL NETWORKS, STATUS UPDATES, FORUMS, AND ELECTRONIC BULLETIN BOARDS; THE FOREGOING EXCLUDING LOYALTY REWARD PROGRAMS (U.S. CLS. 100, 101 AND 102).

FIRST USE 6-16-2004; IN COMMERCE 6-16-2004.

H. M. FISHER, EXAMINING ATTORNEY

SN 85-049,397. HIGH LINER FOODS INCORPORATED, LUNENBURG, NOVA SCOTIA, CANADA, FILED 5-27-2010.



PRIORITY CLAIMED UNDER SEC. 44(D) ON CANADA APPLICATION NO. 1480409, FILED 5-10-2010.

THE MARK CONSISTS OF THE WORDS "R.E.S.P.E.C.T." PRINTED IN UPPERCASE STYLIZED LETTERS, WITH THE PHRASE "OUR PLANET, OUR PROMISE" PRINTED IN STYLIZED TYPE BELOW IT. THE LETTERS IN "R.E.S.P.E.C.T." ARE SEPARATED BY CIRCULAR AND OVAL SHAPES REPLACING THE PERIODS, AND THE LETTER "P" IN "R.E.S.P.E.C.T." IS ENCLOSED IN A SPHERE REPRESENTING A DROP OF WATER. CIRCULAR AND OVAL SHAPES OF VARYING SIZE, REPRESENTING DROPS OF WATER, APPEAR ABOVE THE WORD "R.E.S.P.E.C.T."

FOR PROMOTING PUBLIC AWARENESS OF ENVIRONMENTALLY FRIENDLY PRACTICES WITHIN THE SEAFOOD INDUSTRY THROUGH THE OPERATION OF PROMOTIONAL PROGRAMS FOR THE CONSUMPTION OF FISH AND SEAFOOD AND BY MEANS OF EXHIBITING AT TRADE SHOWS, FAIRS, SPECIAL EVENTS AND BY LIVE PRESENTATIONS FOR THE BENEFIT OF FISH WHOLESALERS, RETAILERS AND CONSUMERS; PROMOTING PUBLIC AWARENESS OF SUSTAINABLE SEAFOOD THROUGH OPERATION OF MARKETING PROGRAMS FOR WHOLESALERS, RETAILERS AND CONSUMERS AND BY MEANS OF EXHIBITING AT TRADE SHOWS, FAIRS, SPECIAL EVENTS AND BY LIVE PRESENTATIONS IN RESPECT OF FISH AND SEAFOOD; OPERATION OF A BUSINESS FOR OTHERS, NAMELY, A WHOLESALE DISTRIBUTORSHIP SUPPLYING PRIVATE LABEL FISH AND SEAFOOD TO FOOD RETAILERS AND FOOD SERVICE DISTRIBUTORS (U.S. CLS. 100, 101 AND 102).

FIRST USE 3-31-2010; IN COMMERCE 3-31-2010.
CHRISTINA SOBRAL, EXAMINING ATTORNEY

SN 85-026,796. CONNEXITY LLC, CAMARILLO, CA. FILED 4-29-2010.

CONNEXITY

THE MARK CONSISTS OF STANDARD CHARACTERS WITHOUT CLAIM TO ANY PARTICULAR FONT, STYLE, SIZE, OR COLOR.

FOR ON-LINE ADVERTISING AND MARKETING SERVICES (U.S. CLS. 100, 101 AND 102).

FIRST USE 4-29-2010; IN COMMERCE 4-29-2010.
SARA BENJAMIN, EXAMINING ATTORNEY

CLASS 35—(Continued).

SN 85-065,332. TRIPLE CANOPY, INC., HERNDON, VA. FILED 6-17-2010.

ASSESS AVERT ACHIEVE

THE MARK CONSISTS OF STANDARD CHARACTERS WITHOUT CLAIM TO ANY PARTICULAR FONT, STYLE, SIZE, OR COLOR.

FOR MANAGEMENT OF FACILITIES AT MILITARY, GOVERNMENTAL, NONGOVERNMENTAL AND COMMERCIAL BASE CAMPS; LOGISTICAL SERVICES IN THE NATURE OF WEAPONS PROCUREMENT (U.S. CLS. 100, 101 AND 102).

SUSAN RICHARDS, EXAMINING ATTORNEY

SN 85-072,218. CHASES TREASURES, NEW YORK, NY. FILED 6-25-2010.



THE STIPLING IS FOR SHADING PURPOSES ONLY. THE COLOR(S) BLUE, HOT PINK, ORANGE AND MINT GREEN IS/ARE CLAIMED AS A FEATURE OF THE MARK.

THE MARK CONSISTS OF A LIGHT BLUE CRESCENT MOON WITH A SMILING FACE, SURROUNDED BY 3 STARS, ONE HOT PINK, ONE ORANGE, AND ONE MINT GREEN. TO THE RIGHT OF THE MOON ARE THE WORDS "CHASE'S TREASURES", WHICH APPEAR IN 2 DIFFERENT COLORS OF BLUE.

FOR ON-LINE RETAIL STORE SERVICES FEATURING BABY AND CHILDREN'S CLOTHING, TOYS AND GEAR, AND WOMEN'S JEWELRY (U.S. CLS. 100, 101 AND 102).

FIRST USE 7-1-2004; IN COMMERCE 6-21-2006.

TINA MAI, EXAMINING ATTORNEY

CLASS 35—(Continued).

SN 85-074,552. NOVATION, LLC, IRVING, TX. FILED 6-30-2010.

Novation

OWNER OF U.S. REG. NO. 2,371,501.

THE MARK CONSISTS OF THE WORDING "NOVATION" WITH A STYLIZED COMET DESIGN FORMING THE DOT IN THE LETTER "I" WITH THE TAIL STREAMING OVER THE LETTERS "OVAT".

FOR BUSINESS MANAGEMENT ANALYSIS AND CONSULTATION PERTAINING TO SUPPLY CHAIN LOGISTICS AND MANAGEMENT SERVICES; CONTRACT NEGOTIATION SERVICES ON BEHALF OF HEALTH CARE AND NON-HEALTH CARE ENTITIES, INCLUDING EDUCATIONAL INSTITUTIONS, MUNICIPALITIES AND CORPORATE ENTITIES, NAMELY, MANAGING A CONTRACTING PROCESS ON BEHALF OF SUCH ENTITIES IN THE NATURE OF PROCURING OF CONTRACTS FOR THE PURCHASE AND SALE OF GOODS AND SERVICES (U.S. CLS. 100, 101 AND 102).

FIRST USE 3-0-2001; IN COMMERCE 3-0-2001.

MATTHEW MCDOWELL, EXAMINING ATTORNEY

SN 85-083,189. DOTOMI, INC., CHICAGO, IL. FILED 7-13-2010.

PROMOBUILDER

THE MARK CONSISTS OF STANDARD CHARACTERS WITHOUT CLAIM TO ANY PARTICULAR FONT, STYLE, SIZE, OR COLOR.

FOR ADVERTISING VIA ELECTRONIC MEDIA AND SPECIFICALLY THE INTERNET EXCLUDING THE MEDICAL FIELD; DISSEMINATION OF ADVERTISING FOR OTHERS VIA THE INTERNET EXCLUDING THE MEDICAL FIELD (U.S. CLS. 100, 101 AND 102).

THOMAS MANOR, EXAMINING ATTORNEY

SN 85-096,293. BAXTER, DAVID, SANTA CRUZ, CA. FILED 7-29-2010.

CarSavingsNow.com

THE MARK CONSISTS OF STANDARD CHARACTERS WITHOUT CLAIM TO ANY PARTICULAR FONT, STYLE, SIZE, OR COLOR.

FOR ADVERTISING AND DIRECTORY SERVICES, NAMELY, PROMOTING THE SERVICES OF OTHERS BY PROVIDING A WEB PAGE ORGANIZED BY CITY AND FEATURING LINKS TO WEBSITES OF OTHERS OFFERING AUTOMOTIVE SERVICES (U.S. CLS. 100, 101 AND 102).

FIRST USE 6-20-2009; IN COMMERCE 7-5-2010.

MARK SPARACINO, EXAMINING ATTORNEY

CLASS 35—(Continued).

SN 85-104,876. DAYMON INTERACTIONS INC., STAMFORD, CT. FILED 8-11-2010.

DAYMON INTERACTIONS

THE MARK CONSISTS OF STANDARD CHARACTERS WITHOUT CLAIM TO ANY PARTICULAR FONT, STYLE, SIZE, OR COLOR.

FOR DEMONSTRATING THE GOODS OF OTHERS IN RETAIL STORES AND PROVIDING PRODUCT SAMPLES OF OTHERS IN RETAIL STORES (U.S. CLS. 100, 101 AND 102).

FIRST USE 7-12-2009; IN COMMERCE 7-12-2009.
MICHAEL WIENER, EXAMINING ATTORNEY

SN 85-107,694. NADINE WEIL, SAN FRANCISCO, CA. FILED 8-14-2010.



THE COLOR(S) GREEN AND WHITE IS/ARE CLAIMED AS A FEATURE OF THE MARK.

THE MARK CONSISTS OF THE WORDS "HEART OF GREEN" IN THE COLOR GREEN WITH A GREEN STYLIZED HEART TO THE LEFT ON A WHITE BACKGROUND.

FOR PROMOTING ENVIRONMENTAL AWARENESS AT LIVE EVENTS; SPECIAL EVENT PLANNING FOR BUSINESS PURPOSES IN THE FIELD OF ENVIRONMENTALLY-SUSTAINABLE PRACTICES; ORGANIZING, PROMOTING AND CONDUCTING EXHIBITIONS, TRADESHOWS AND EVENTS FOR BUSINESS PURPOSES IN THE FIELD OF ENVIRONMENTALLY-SUSTAINABLE PRACTICES (U.S. CLS. 100, 101 AND 102).

FIRST USE 10-8-2006; IN COMMERCE 10-8-2006.
ROBERT C. CLARK JR., EXAMINING ATTORNEY

SN 85-109,211. CLOUD SECURITY ALLIANCE, FERNDALE, WA. FILED 8-17-2010.



NO CLAIM IS MADE TO THE EXCLUSIVE RIGHT TO USE "CLOUD SECURITY ALLIANCE", APART FROM THE MARK AS SHOWN.

THE MARK CONSISTS OF THE LETTERS "CSA" IN A STYLIZED FORM NEXT TO THE WORDS "CLOUD SECURITY ALLIANCE".

FOR PROMOTING THE USE OF THE SECURITY ASSURANCE BEST PRACTICES OF OTHERS IN THE FIELD OF CLOUD COMPUTING (U.S. CLS. 100, 101 AND 102).

FIRST USE 3-31-2009; IN COMMERCE 3-31-2009.
HEATHER THOMPSON, EXAMINING ATTORNEY

CLASS 35—(Continued).

SN 85-110,469. COUNCIL OF FASHION DESIGNERS OF AMERICA, INC., AKA CFDA, NEW YORK, NY. FILED 8-18-2010.

CFDA FASHION INCUBATOR

THE MARK CONSISTS OF STANDARD CHARACTERS WITHOUT CLAIM TO ANY PARTICULAR FONT, STYLE, SIZE, OR COLOR.

OWNER OF U.S. REG. NO. 2,037,093.
NO CLAIM IS MADE TO THE EXCLUSIVE RIGHT TO USE "FASHION INCUBATOR", APART FROM THE MARK AS SHOWN.

FOR BUSINESS SERVICES, NAMELY, BUSINESS CONSULTING, BUSINESS DEVELOPMENT; BUSINESS STAFF SUPPORT SERVICES IN THE NATURE OF ORGANIZATION OF RECEPTIONIST SERVICES, MAIL SORTING, HANDLING AND RECEIVING (U.S. CLS. 100, 101 AND 102).

FIRST USE 11-1-2009; IN COMMERCE 11-1-2009.
CAROLINE WOOD, EXAMINING ATTORNEY

SN 85-111,995. IOS HEALTH SYSTEMS, INC., MIAMI, FL. FILED 8-20-2010.



NO CLAIM IS MADE TO THE EXCLUSIVE RIGHT TO USE "HEALTH SYSTEMS", APART FROM THE MARK AS SHOWN.

THE COLOR(S) BLUE, GOLD, GRAY IS/ARE CLAIMED AS A FEATURE OF THE MARK.

THE MARK CONSISTS OF "IOS" IN BLUE WITH THE WORDING "HEALTH SYSTEMS" BELOW IN GRAY THE DOT ABOVE THE LETTER "I" IS HOLLOW IN THE CENTER ABOVE THE "I" IS A CURVE DESIGN IN GOLD.

FOR PROVIDING AN INTERNET DATABASE OF PATIENT MEDICAL INFORMATION TO FACILITATE PATIENT-AUTHORIZED, HIPAA-COMPLIANT SHARING OF PATIENT MEDICAL INFORMATION AMONGST PATIENTS, PHYSICIANS AND ORGANIZATIONS SUCH THAT THIS INFORMATION CAN BE DIRECTLY INSERTED INTO THE DOCTOR'S MEDICAL REPORTS AS A MEANS OF INCREASING MEDICAL RECORD GENERATION EFFICIENCY AND ACCURACY (U.S. CLS. 100, 101 AND 102).

FIRST USE 7-7-2007; IN COMMERCE 7-7-2007.
MAYUR VAGHANI, EXAMINING ATTORNEY

CLASS 35—(Continued).

SN 85-115,462. CREATIVE REALITIES, INC., BOSTON, MA. FILED 8-25-2010.

CREATIVE REALITIES

THE MARK CONSISTS OF STANDARD CHARACTERS WITHOUT CLAIM TO ANY PARTICULAR FONT, STYLE, SIZE, OR COLOR.

FOR BUSINESS CONSULTATION SERVICES, NAMELY, STRATEGIC BUSINESS PLANNING; CUSTOMER RELATIONS, NAMELY, CUSTOMER RELATIONSHIP MANAGEMENT (U.S. CLS. 100, 101 AND 102).

FIRST USE 8-1-1988; IN COMMERCE 8-1-1988.
MICHAEL TANNER, EXAMINING ATTORNEY

SN 85-116,990. NABVETS, AKA NATIONAL ASSOCIATION FOR BLACK VETERANS, INC., MILWAUKEE, WI. FILED 8-26-2010.

NABVETS

THE MARK CONSISTS OF STANDARD CHARACTERS WITHOUT CLAIM TO ANY PARTICULAR FONT, STYLE, SIZE, OR COLOR.

SEC. 2(F).

FOR CHARITABLE SERVICES, NAMELY, ORGANIZING AND CONDUCTING VOLUNTEER PROGRAMS AND COMMUNITY SERVICE PROJECTS AIMED AT INCREASING SUPPORT AND MORALE OF FAMILIES OF DECEASED WAR VETERANS, WAR VETERANS, CURRENT MEMBERS AND FUTURE MEMBERS OF THE U.S. MILITARY (U.S. CLS. 100, 101 AND 102).

FIRST USE 6-9-1970; IN COMMERCE 6-9-1970.
C. DIONNE CLYBURN, EXAMINING ATTORNEY

SN 85-119,343. DENTON, ERIC, CARLSBAD, CA. FILED 8-31-2010.

MUSIC POWER

THE MARK CONSISTS OF STANDARD CHARACTERS WITHOUT CLAIM TO ANY PARTICULAR FONT, STYLE, SIZE, OR COLOR.

OWNER OF U.S. REG. NO. 3,368,158.

NO CLAIM IS MADE TO THE EXCLUSIVE RIGHT TO USE "MUSIC", APART FROM THE MARK AS SHOWN.

FOR ON-LINE RETAIL STORE SERVICES FEATURING MUSICAL INSTRUMENTS AND RELATED ACCESSORIES (U.S. CLS. 100, 101 AND 102).

FIRST USE 12-21-2008; IN COMMERCE 12-22-2008.
KATHERINE E. HALMEN, EXAMINING ATTORNEY

CLASS 35—(Continued).

SN 85-122,096. I2A SOLUTIONS INC, SAN DIEGO, CA. FILED 9-2-2010.

Ideas into Applications

THE MARK CONSISTS OF STANDARD CHARACTERS WITHOUT CLAIM TO ANY PARTICULAR FONT, STYLE, SIZE, OR COLOR.

FOR PROVIDING BUSINESS MANAGEMENT INFORMATION IN CONNECTION WITH CONSULTING AND ADVISORY SERVICES IN THE FIELD OF STRATEGIC PLANNING (U.S. CLS. 100, 101 AND 102).

FIRST USE 3-1-2010; IN COMMERCE 3-1-2010.
JESSICA A. POWERS, EXAMINING ATTORNEY

SN 85-125,044. GREEN WORKS, LLC, BATON ROUGE, LA. FILED 9-8-2010.

ECOVIA

THE MARK CONSISTS OF STANDARD CHARACTERS WITHOUT CLAIM TO ANY PARTICULAR FONT, STYLE, SIZE, OR COLOR.

FOR DISTRIBUTORSHIP SERVICES IN THE FIELD OF FINISHED BUILDING MATERIALS, CONSTRUCTION TOOLS AND CONSTRUCTION EQUIPMENT; SALES PROMOTION SERVICES FEATURING WHOLESALE FINISHED BUILDING MATERIALS, CONSTRUCTION TOOLS AND CONSTRUCTION EQUIPMENT (U.S. CLS. 100, 101 AND 102).

COLLEEN KEARNEY, EXAMINING ATTORNEY

SN 85-126,482. MIKO, VICKI, DBA FRILLED LIZARD PRODUCTIONS, MURRIETA, CA. AND HARPER, LYNN, DBA FRILLED LIZARD PRODUCTIONS, CARLSBAD, CA. FILED 9-9-2010.

Frilled Lizard Productions

THE MARK CONSISTS OF STANDARD CHARACTERS WITHOUT CLAIM TO ANY PARTICULAR FONT, STYLE, SIZE, OR COLOR.

NO CLAIM IS MADE TO THE EXCLUSIVE RIGHT TO USE "PRODUCTIONS", APART FROM THE MARK AS SHOWN.

FOR PROVIDING CONSULTING SERVICES IN THE FIELD OF FACILITATING THE PLANNING, BUYING, AND SELLING OF MEDIA (U.S. CLS. 100, 101 AND 102).

FIRST USE 8-23-2010; IN COMMERCE 9-6-2010.
WENDY JUN, EXAMINING ATTORNEY

CLASS 35—(Continued).

SN 85-126,536. KRS INTERNATIONAL, LLC., DORAL, FL. FILED 9-10-2010.



NO CLAIM IS MADE TO THE EXCLUSIVE RIGHT TO USE "USA AND INTERNATIONAL, LLC", APART FROM THE MARK AS SHOWN.

THE COLOR(S) BLUE, GREEN AND ORANGE IS/ARE CLAIMED AS A FEATURE OF THE MARK.

THE MARK CONSISTS OF IMAGE OF GLOBE IN BLUE AND GREEN COLOR WITH THE WORDS "KRS" WRITTEN VERTICALLY TO "KRS". THE WORDS "KR'S INTERNATIONAL, LLC." IS WRITTEN TO THE RIGHT HAND SIDE OF THE GLOBE IN BLUE COLOR AS SHOWN IN THE MARK.

FOR ADVERTISING SERVICES, RETAIL STORE SERVICES FEATURING AFTERMARKET CAR PRODUCTS (U.S. CLS. 100, 101 AND 102).

BRIAN NEVILLE, EXAMINING ATTORNEY

SN 85-127,829. GFK HEALTHCARE, LP, BLUE BELL, PA. FILED 9-13-2010.

**MEDICAL MARKETING
CONFERENCE**

THE MARK CONSISTS OF STANDARD CHARACTERS WITHOUT CLAIM TO ANY PARTICULAR FONT, STYLE, SIZE, OR COLOR.

OWNER OF U.S. REG. NOS. 952,465 AND 2,824,740. SEC. 2(F).

FOR MARKET RESEARCH FOR PHARMACEUTICAL COMPANIES DEALING WITH PHYSICIANS (U.S. CLS. 100, 101 AND 102).

FIRST USE 8-25-1969; IN COMMERCE 8-25-1969.
ERNEST SHOSHO, EXAMINING ATTORNEY

SN 85-131,456. LENMAR ENTERPRISES, INC., CAMARILLO, CA. FILED 9-16-2010.

BATTERY CENTRAL

THE MARK CONSISTS OF STANDARD CHARACTERS WITHOUT CLAIM TO ANY PARTICULAR FONT, STYLE, SIZE, OR COLOR.

NO CLAIM IS MADE TO THE EXCLUSIVE RIGHT TO USE "BATTERY", APART FROM THE MARK AS SHOWN.

FOR IN STORE SERVICES ADVERTISING BATTERIES AND BATTERY CHARGING DEVICES; ADVERTISING BATTERIES AND BATTERY CHARGING DEVICES ON KIOSKS (U.S. CLS. 100, 101 AND 102).

MARK SHINER, EXAMINING ATTORNEY

CLASS 35—(Continued).

SN 85-132,139. MILK PROMOTION SERVICES OF INDIANA, INC., INDIANAPOLIS, IN. FILED 9-17-2010.



OWNER OF U.S. REG. NO. 1,754,601.

THE MARK CONSISTS OF THE WORDS "WINNERS DRINK MILK" AND A MILK BOTTLE AND CHECKERED FLAG.

FOR ADVERTISING SERVICES RELATED TO THE PROMOTION OF DAIRY PRODUCTS AND PRODUCERS (U.S. CLS. 100, 101 AND 102).

FIRST USE 10-5-1991; IN COMMERCE 10-5-1991.

JULIE WATSON, EXAMINING ATTORNEY

SN 85-132,256. MILK PROMOTION SERVICES OF INDIANA, INC., INDIANAPOLIS, IN. FILED 9-17-2010.



THE MARK CONSISTS OF THE WORDS "WINNERS DRINK MILK" SUPERIMPOSED ON A MUSICAL CLEFT AND A MILK BOTTLE.

FOR ADVERTISING SERVICES RELATED TO THE PROMOTION OF DAIRY PRODUCTS AND PRODUCERS (U.S. CLS. 100, 101 AND 102).

FIRST USE 10-31-2006; IN COMMERCE 10-31-2006.

JULIE WATSON, EXAMINING ATTORNEY

SN 85-134,523. PISKORSKI, MIKOLAJ JAN, BOSTON, MA. FILED 9-21-2010.

Mikolaj Jan Piskorski

THE MARK CONSISTS OF STANDARD CHARACTERS WITHOUT CLAIM TO ANY PARTICULAR FONT, STYLE, SIZE, OR COLOR.

THE NAME "MIKOLAJ JAN PISKORSKI" IDENTIFIES A LIVING INDIVIDUAL WHOSE CONSENT IS OF RECORD.

FOR ADVERTISING AND MARKETING CONSULTANCY; BUSINESS CONSULTATION (U.S. CLS. 100, 101 AND 102).

LEIGH CAROLINE CASE, EXAMINING ATTORNEY

CLASS 35—(Continued).

SN 85-134,738. AMDEC, LLC, NEW YORK, NY. FILED 9-21-2010.

AMDEC

THE MARK CONSISTS OF STANDARD CHARACTERS WITHOUT CLAIM TO ANY PARTICULAR FONT, STYLE, SIZE, OR COLOR.

FOR ASSOCIATION SERVICES, NAMELY, PROMOTING THE INTERESTS OF MEMBER ACADEMIC RESEARCH INSTITUTIONS FOR THE BENEFIT AND ADVANCEMENT OF BIOMEDICAL RESEARCH (U.S. CLS. 100, 101 AND 102).

FIRST USE 7-0-1997; IN COMMERCE 7-0-1997.
MAUREEN DALL, EXAMINING ATTORNEY

SN 85-136,697. AQREVA, LLC, SIOUX FALLS, ND. FILED 9-23-2010.

Aqreva

THE MARK CONSISTS OF STANDARD CHARACTERS WITHOUT CLAIM TO ANY PARTICULAR FONT, STYLE, SIZE, OR COLOR.

THE WORDING "AQREVA" HAS NO MEANING IN A FOREIGN LANGUAGE.

FOR MEDICAL BILLING OUTSOURCING SERVICES; MEDICAL BILLING SUPPORT SERVICES; MEDICAL CLAIMS MANAGEMENT SERVICES, NAMELY, ELECTRONIC RE-PRICING OF PHYSICIAN, HOSPITAL, AND ANCILLARY MEDICAL CARE PROVIDER TRANSACTIONS VIA THE GLOBAL INFORMATION NETWORK; MEDICAL CLAIMS MANAGEMENT SERVICES, NAMELY, RECEIVING, DATA ENTERING, AND RE-PRICING OF TRANSACTIONS THAT ARE ORIGINATED BY PHYSICIANS, HOSPITALS, AND ANCILLARY MEDICAL CARE PROVIDERS; MEDICAL COST MANAGEMENT (U.S. CLS. 100, 101 AND 102).

TINA BROWN, EXAMINING ATTORNEY

CLASS 35—(Continued).

SN 85-138,078. U.S. DEPARTMENT OF EDUCATION, WASHINGTON, DC. FILED 9-24-2010.

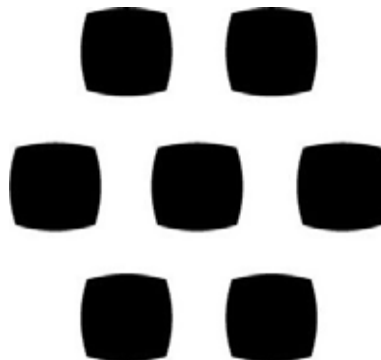

THE MARK CONSISTS OF 7 DOTS WITH ONE IN THE CENTER AND 6 SURROUNDING.

FOR PROVIDING A TEACHER RECRUITMENT CAMPAIGN IN THE NATURE OF PROVIDING THE RECRUITMENT OF TEACHERS FOR ELEMENTARY, MIDDLE AND HIGH SCHOOLS AND PROMOTING PUBLIC AWARENESS OF THE TEACHING PROFESSION (U.S. CLS. 100, 101 AND 102).

FIRST USE 5-15-2010; IN COMMERCE 5-15-2010.
LAURIE MAYES, EXAMINING ATTORNEY

SN 85-140,492. USIPN HOLDINGS LLC, MACCLENNY, FL. FILED 9-28-2010.

PRESTIGERX PHARMACY

THE MARK CONSISTS OF STANDARD CHARACTERS WITHOUT CLAIM TO ANY PARTICULAR FONT, STYLE, SIZE, OR COLOR.

NO CLAIM IS MADE TO THE EXCLUSIVE RIGHT TO USE "PHARMACY", APART FROM THE MARK AS SHOWN.

FOR RETAIL PHARMACY SERVICES (U.S. CLS. 100, 101 AND 102).

CIMMERIAN COLEMAN, EXAMINING ATTORNEY

CLASS 35—(Continued).

SN 85-142,545. ROTH I.G.A. FOODLINER, INCORPORATED, SALEM, OR. FILED 9-30-2010.

FRESH MARKET AT ROTH'S

THE MARK CONSISTS OF STANDARD CHARACTERS WITHOUT CLAIM TO ANY PARTICULAR FONT, STYLE, SIZE, OR COLOR.

OWNER OF U.S. REG. NO. 2,268,623.

NO CLAIM IS MADE TO THE EXCLUSIVE RIGHT TO USE "FRESH MARKET", APART FROM THE MARK AS SHOWN.

FOR RETAIL GROCERY STORE SERVICES (U.S. CLS. 100, 101 AND 102).

FIRST USE 2-10-2000; IN COMMERCE 2-10-2000.

STEVEN JACKSON, EXAMINING ATTORNEY

SN 85-143,949. SUSUMI INVESTMENTS, LLC, EL PASO, TX. FILED 10-4-2010.

AKARI
JAPANESE BISTRO

NO CLAIM IS MADE TO THE EXCLUSIVE RIGHT TO USE "JAPANESE BISTRO", APART FROM THE MARK AS SHOWN.

THE MARK CONSISTS OF "AKARI JAPANESE BISTRO". THE ENGLISH TRANSLATION OF "AKARI" IN THE MARK IS "LIGHT".

FOR FRANCHISING, NAMELY, OFFERING BUSINESS MANAGEMENT ASSISTANCE IN THE ESTABLISHMENT AND/OR OPERATION OF A JAPANESE RESTAURANT; OFFERING BUSINESS MANAGEMENT ASSISTANCE IN THE ESTABLISHMENT AND/OR OPERATION OF RESTAURANTS; RESTAURANT FRANCHISING, NAMELY, OFFERING BUSINESS MANAGEMENT ASSISTANCE IN THE ESTABLISHMENT AND/OR OPERATION OF RESTAURANTS; RESTAURANT MANAGEMENT FOR OTHERS (U.S. CLS. 100, 101 AND 102).

BRIAN CALLAGHAN, EXAMINING ATTORNEY

SN 85-145,930. WAYNE AUTO SALVAGE, INC., GOLDSBORO, NC. FILED 10-6-2010.

BEVELL'S PULL IT YOURSELF

THE MARK CONSISTS OF STANDARD CHARACTERS WITHOUT CLAIM TO ANY PARTICULAR FONT, STYLE, SIZE, OR COLOR.

FOR RETAIL STORE SERVICES FEATURING AUTOMOBILE PARTS (U.S. CLS. 100, 101 AND 102).

FIRST USE 2-0-2010; IN COMMERCE 2-0-2010.

SHAUNIA CARLYLE, EXAMINING ATTORNEY

CLASS 35—(Continued).

SN 85-148,530. THE TRUSTEE OF THE RODNEY A HAMILTON LIVING TRUST, THE TRUSTEE COMPRISING RODNEY A. HAMILTON, A U.S. CITIZEN, LOS ANGELES, CA. FILED 10-8-2010.

No time for generic brands

THE MARK CONSISTS OF STANDARD CHARACTERS WITHOUT CLAIM TO ANY PARTICULAR FONT, STYLE, SIZE, OR COLOR.

FOR ADVERTISING RELATING TO ELECTRONIC PRODUCTS, CLOCKS AND GENUINE BRANDS (U.S. CLS. 100, 101 AND 102).

FIRST USE 10-6-2010; IN COMMERCE 10-6-2010.

TARA PATE, EXAMINING ATTORNEY

SN 85-152,295. PICKHOLZ JASON, NEW YORK, NY. FILED 10-14-2010.

LAWYEROWL

THE MARK CONSISTS OF STANDARD CHARACTERS WITHOUT CLAIM TO ANY PARTICULAR FONT, STYLE, SIZE, OR COLOR.

FOR ONLINE LAWYER REFERRALS (U.S. CLS. 100, 101 AND 102).

FIRST USE 7-9-2011; IN COMMERCE 7-9-2011.

KIM SAITO, EXAMINING ATTORNEY

CLASS 35—(Continued).

SN 85-155,991. THE AMERICAN NATURAL GAS ALLIANCE, INC., WASHINGTON, DC. FILED 10-19-2010.



NO CLAIM IS MADE TO THE EXCLUSIVE RIGHT TO USE "NATURAL GAS NY" AND THE DESIGN OF THE STATE OF NEW YORK, APART FROM THE MARK AS SHOWN.

THE MARK CONSISTS OF THE WORDS "FRIENDS OF" ON TOP OF THE WORD "NATURAL", ALL TO THE LEFT OF AN OUTLINED DRAWING OF THE STATE OF NEW YORK; THE WORDS "GAS NY" OVERLAYING THE STATE DESIGN; THE TOP OF THE LETTER "A" IN "GAS" HAS A FLAME DESIGN.

FOR ASSOCIATION SERVICES, NAMELY, PROMOTING THE PUBLIC INTERESTS AND AWARENESS IN THE BENEFITS OF NATURAL GAS; ADVERTISING SERVICES, NAMELY, DEVELOPING AND DISSEMINATING PRINTED AND ONLINE PROMOTIONAL OR ADVERTISING MATERIALS IN THE FIELD OF NATURAL GAS (U.S. CLS. 100, 101 AND 102).

FIRST USE 6-4-2010; IN COMMERCE 9-29-2010.

ANDREA K. NADELMAN, EXAMINING ATTORNEY

SN 85-156,722. TRIBUNE INTERACTIVE, INC., CHICAGO, IL. FILED 10-20-2010.

LIQUID COUPON

THE MARK CONSISTS OF STANDARD CHARACTERS WITHOUT CLAIM TO ANY PARTICULAR FONT, STYLE, SIZE, OR COLOR.

NO CLAIM IS MADE TO THE EXCLUSIVE RIGHT TO USE "COUPON", APART FROM THE MARK AS SHOWN.

FOR PROMOTING THE GOODS AND SERVICES OF OTHERS VIA A GLOBAL COMPUTER NETWORK (U.S. CLS. 100, 101 AND 102).

CHRISTOPHER BUONGIORNO, EXAMINING ATTORNEY

CLASS 35—(Continued).

SN 85-158,772. EXPRESS SCRIPTS, INC., ST. LOUIS, MO. FILED 10-22-2010.

ECONDISC CONTRACTING SOLUTIONS

THE MARK CONSISTS OF STANDARD CHARACTERS WITHOUT CLAIM TO ANY PARTICULAR FONT, STYLE, SIZE, OR COLOR.

NO CLAIM IS MADE TO THE EXCLUSIVE RIGHT TO USE "CONTRACTING SOLUTIONS", APART FROM THE MARK AS SHOWN.

FOR GROUP PURCHASING ORGANIZATION SERVICES, NAMELY, PURCHASING AGENT SERVICES; GROUP PURCHASING ORGANIZATION SERVICES, NAMELY, COORDINATION AND NEGOTIATION OF CONTRACTS FOR OTHERS TO PURCHASE PHARMACEUTICALS AND RELATED GOODS AND SERVICES; ASSISTING WITH THE NEGOTIATION OF CONTRACTS WITH PHARMACEUTICAL MANUFACTURERS AND SUPPLIERS; PHARMACY SERVICES, NAMELY, PROVIDING STRATEGIC ANALYSIS AND ADVICE REGARDING PHARMACY PROCUREMENT CONTRACTS FOR THE PURCHASE AND SALE OF GOODS AND SERVICES; ASSISTING WITH THE FORMATION, NEGOTIATION, AND MANAGEMENT OF CONTRACTS WITH PHARMACEUTICAL MANUFACTURERS AND SUPPLIERS FOR THE PURCHASE AND SALE OF GOODS AND SERVICES (U.S. CLS. 100, 101 AND 102).

JEAN IM, EXAMINING ATTORNEY

SN 85-161,573. MAURICES INCORPORATED, DULUTH, MN. FILED 10-26-2010.

WINSPIRE

THE MARK CONSISTS OF STANDARD CHARACTERS WITHOUT CLAIM TO ANY PARTICULAR FONT, STYLE, SIZE, OR COLOR.

THE WORDING "WINSPIRE" HAS NO MEANING IN A FOREIGN LANGUAGE.

FOR CONTESTS AND INCENTIVE AWARD PROGRAMS TO ENCOURAGE RETAIL STORE MANAGERS AND DISTRICT MANAGERS TO ACHIEVE GOALS IN VARIOUS CATEGORIES, NAMELY, SALES, MARKETING, CREDIT CARD APPLICATIONS AND ADVERTISING (U.S. CLS. 100, 101 AND 102).

BILL DAWE, EXAMINING ATTORNEY

CLASS 35—(Continued).

SN 85-162,073. PROTECT AMERICA, INC., ROUND ROCK, TX. FILED 10-27-2010.



THE MARK CONSISTS OF STAR WITH LETTERS "P","A" OVERLAY.

FOR ON-LINE RETAIL STORE SERVICES FEATURING HOME AND COMMERCIAL SECURITY AND ALARM SYSTEMS (U.S. CLS. 100, 101 AND 102).

FIRST USE 12-31-2004; IN COMMERCE 12-31-2004.
WILLIAM ROSSMAN, EXAMINING ATTORNEY

CLASS 35—(Continued).

SN 85-162,714. MICHEL EDOUARD ROGER CELAYETA, DISTRITO FEDERAL, MEXICO, FILED 10-27-2010.



SN 85-162,112. PROTECT AMERICA, INC., ROUND ROCK, TX. FILED 10-27-2010.

PROTECT AMERICA

THE MARK CONSISTS OF STANDARD CHARACTERS WITHOUT CLAIM TO ANY PARTICULAR FONT, STYLE, SIZE, OR COLOR.

OWNER OF U.S. REG. NO. 1,853,965.

NO CLAIM IS MADE TO THE EXCLUSIVE RIGHT TO USE "AMERICA", APART FROM THE MARK AS SHOWN.

FOR ON-LINE RETAIL STORE SERVICES FEATURING HOME AND COMMERCIAL SECURITY AND ALARM SYSTEMS (U.S. CLS. 100, 101 AND 102).

FIRST USE 12-31-1993; IN COMMERCE 12-31-1993.

WILLIAM ROSSMAN, EXAMINING ATTORNEY

OWNER OF MEXICO REG. NO. 1075028, DATED 11-28-2008, EXPIRES 11-28-2018.

THE COLOR(S) RED, BLUE, GRAY, WHITE AND YELLOW IS/ARE CLAIMED AS A FEATURE OF THE MARK.

THE MARK CONSISTS OF THE WORDS "TU BEBÉ Y TÚ" ARRANGED WITH THE WORD "TU" AT THE TOP APPEARING IN BLUE, "BEBÉ" UNDERNEATH APPEARING IN RED AND YELLOW; "Y" APPEARING IN BLUE AND "TÚ" APPEARING IN RED. THE MARK IS OUTLINED IN GRAY AND WHITE.

THE ENGLISH TRANSLATION OF WORDS "TU BEBÉ Y TÚ" IS "YOUR BABY AND YOU".

FOR (BASED ON USE IN COMMERCE) ADVERTISING AND MARKETING(BASED ON 44(E)) ADVERTISING AND MARKETING (U.S. CLS. 100, 101 AND 102).

FIRST USE 11-28-2008; IN COMMERCE 11-28-2008.

SAIMA MAKHDOOM, EXAMINING ATTORNEY

CLASS 35—(Continued).

SN 85-162,863. BIOFUELS AUTOMATION, INC., PLYMOUTH, MN. FILED 10-27-2010.



NO CLAIM IS MADE TO THE EXCLUSIVE RIGHT TO USE "SALES", APART FROM THE MARK AS SHOWN.

THE MARK CONSISTS OF THE STYLIZED TERM "TITAN" WITH A STYLIZED FLAME DOTTING THE LETTER "I" AND SHADED TERM "SALES" WITH A PARTIAL BIFURCATED SHIELD TO THE LEFT CONTAINING THREE WAVY LINES AND TWO OVERLAPPING WATER DROPS.

FOR BUSINESS MARKETING SERVICES IN THE FIELD OF ENERGY TRANSFER APPARATUS, NAMELY, HEAT EXCHANGERS NOT BEING PART OF MACHINES, FOR HARNESSING AND RE-DIRECTING HEAT, DURING THE MANUFACTURING OR ENERGY PRODUCTION PROCESSES FOR USE IN OTHER PARTS OF THOSE PROCESSES OR BUILDING; ADVERTISING AND MARKETING IN THE FIELD OF ENERGY TRANSFER APPARATUS, NAMELY, HEAT EXCHANGERS NOT BEING PART OF MACHINES, FOR HARNESSING AND RE-DIRECTING HEAT, DURING THE MANUFACTURING OR ENERGY PRODUCTION PROCESSES FOR USE IN OTHER PARTS OF THOSE PROCESSES OR BUILDING; BUSINESS MARKETING SERVICES IN THE FIELD OF INSTALLATION AND DESIGN SERVICES RELATED TO ENERGY TRANSFER APPARATUS, NAMELY, HEAT EXCHANGERS NOT BEING PART OF MACHINES, FOR HARNESSING AND RE-DIRECTING HEAT DURING THE MANUFACTURING OR ENERGY PRODUCTION PROCESSES FOR USE IN OTHER PARTS OF THOSE PROCESSES OR BUILDING; ADVERTISING AND MARKETING SERVICES IN THE FIELD OF INSTALLATION AND DESIGN SERVICES RELATED TO ENERGY TRANSFER APPARATUS, NAMELY, HEAT EXCHANGERS NOT BEING PART OF MACHINES, FOR HARNESSING AND RE-DIRECTING HEAT DURING THE MANUFACTURING OR ENERGY PRODUCTION PROCESSES FOR USE IN OTHER PARTS OF THOSE PROCESSES OR BUILDING (U.S. CLS. 100, 101 AND 102).

JOHN SCHUYLER YARD, EXAMINING ATTORNEY

SN 85-169,290. DESSY MARKETING & DISTRIBUTION, INC., NEW YORK, NY. FILED 11-4-2010.

NEWLYMAID

THE MARK CONSISTS OF STANDARD CHARACTERS WITHOUT CLAIM TO ANY PARTICULAR FONT, STYLE, SIZE, OR COLOR.

FOR ARRANGING OF TRADING IN BRIDESMAID DRESSES IN EXCHANGE FOR DISCOUNTS AND SAVINGS ON PURCHASES (U.S. CLS. 100, 101 AND 102).

KEVON CHISOLM, EXAMINING ATTORNEY

CLASS 35—(Continued).

SN 85-170,140. DENTON, MIKE, JEFFERSON CITY, TN. FILED 11-5-2010.

My Fabulous Day

THE MARK CONSISTS OF STANDARD CHARACTERS WITHOUT CLAIM TO ANY PARTICULAR FONT, STYLE, SIZE, OR COLOR.

FOR ADVERTISING SERVICES, NAMELY, PROMOTING AND MARKETING THE GOODS AND SERVICES OF OTHERS THROUGH ALL PUBLIC COMMUNICATION MEANS (U.S. CLS. 100, 101 AND 102).

FIRST USE 4-1-2010; IN COMMERCE 7-1-2010.

ELIZABETH KAJUBI, EXAMINING ATTORNEY

SN 85-172,291. LOS BAGELS COMPANY INC., DBA LOS BAGELS, ARCATA, CA. FILED 11-9-2010.

Los Bagels

THE MARK CONSISTS OF STANDARD CHARACTERS WITHOUT CLAIM TO ANY PARTICULAR FONT, STYLE, SIZE, OR COLOR.

NO CLAIM IS MADE TO THE EXCLUSIVE RIGHT TO USE "BAGELS", APART FROM THE MARK AS SHOWN.

THE ENGLISH TRANSLATION OF "LOS" IN THE MARK IS "THE".

FOR ON-LINE WHOLESALE AND RETAIL STORE SERVICES FEATURING BAGELS AND BAKED GOODS; RETAIL BAKERY SHOPS; TAKE-OUT BAKERY SERVICES; WHOLESALE AND RETAIL STORE SERVICES AND ON-LINE RETAIL AND WHOLESALE STORE SERVICES FEATURING BAGELS AND BAKED GOODS; WHOLESALE DISTRIBUTORSHIPS FEATURING BAGELS (U.S. CLS. 100, 101 AND 102).

FIRST USE 3-0-1984; IN COMMERCE 3-0-1984.

GENE MACIOL, EXAMINING ATTORNEY

SN 85-174,750. REA'S OLIVE RANCH, INC., TEMPE, AZ. FILED 11-11-2010.

OILS AND OLIVES BY QUEEN CREEK OLIVE MILL

THE MARK CONSISTS OF STANDARD CHARACTERS WITHOUT CLAIM TO ANY PARTICULAR FONT, STYLE, SIZE, OR COLOR.

NO CLAIM IS MADE TO THE EXCLUSIVE RIGHT TO USE "OILS AND OLIVES" AND "OLIVE", APART FROM THE MARK AS SHOWN.

FOR RETAIL STORE SERVICES IN THE FIELD OF CLOTHING, LINENS, CANDY, TAPENADES, VINEGARS, OLIVES, OLIVE OILS, OLIVE-OIL BASED BEAUTY PRODUCTS, OLIVE WOOD PRODUCTS, AND SOAPS (U.S. CLS. 100, 101 AND 102).

PAM WILLIS, EXAMINING ATTORNEY

CLASS 35—(Continued).

SN 85-176,000. COMVERGE, INC., NORCROSS, GA. FILED 11-12-2010.

IntelliPLAN

THE MARK CONSISTS OF STANDARD CHARACTERS WITHOUT CLAIM TO ANY PARTICULAR FONT, STYLE, SIZE, OR COLOR.

FOR ENERGY USAGE MANAGEMENT; LOAD MANAGEMENT SERVICES, NAMELY, CONTROLLING ENERGY USAGE AND A WORKING PROGRAM FOR DELIVERING THE SYSTEM OPERATIONS OF SUCH ENERGY MANAGEMENT DEVICES VIA A SWITCH, THERMOSTAT, OR ENERGY MANAGEMENT CONTROLLER LOCATED AT THE END CUSTOMER'S PREMISES; UTILITY BILL MANAGEMENT SERVICES, NAMELY, TRACKING, REPORTING, ANALYZING AND DELIVERING ENERGY INFORMATION IN THE FORM OF THERMOSTAT DISPLAYS, WEB PAGES, OR MAILINGS; MANAGEMENT OF ENERGY DATA, CUSTOMER DATA AND THEIR ENERGY USAGE, NAMELY, MEASUREMENT OR VERIFICATION OF ENERGY USAGE; BUSINESS CONSULTING, MANAGEMENT, PLANNING AND SUPERVISION IN THE FIELD OF ENERGY; INFORMATION AND DATA COMPILING AND ANALYZING RELATING TO BUSINESS MANAGEMENT (U.S. CLS. 100, 101 AND 102).

FIRST USE 10-18-2010; IN COMMERCE 10-18-2010.
KATHY DE JONGE, EXAMINING ATTORNEY

SN 85-176,597. UNITED NATURAL FOODS, INC., PROVIDENCE, RI. FILED 11-15-2010.

YOUR LOCAL ROOTS

THE MARK CONSISTS OF STANDARD CHARACTERS WITHOUT CLAIM TO ANY PARTICULAR FONT, STYLE, SIZE, OR COLOR.

NO CLAIM IS MADE TO THE EXCLUSIVE RIGHT TO USE "LOCAL", APART FROM THE MARK AS SHOWN.

FOR MARKETING SERVICES, NAMELY, PROVIDING AN INFORMATIONAL MARKETING PROGRAM TO PROMOTE THE SALE OF LOCAL PRODUCTS WITHIN NATURAL AND ORGANIC RETAIL GROCERY STORES FOR PARTICIPATING SUPPLIERS (U.S. CLS. 100, 101 AND 102).

TINA MAI, EXAMINING ATTORNEY

CLASS 35—(Continued).

SN 85-177,499. TOTS ON-THE-GO, LLC, MIDLOTHIAN, VA. FILED 11-16-2010.

TOTS ON-THE-GO

THE MARK CONSISTS OF STANDARD CHARACTERS WITHOUT CLAIM TO ANY PARTICULAR FONT, STYLE, SIZE, OR COLOR.

NO CLAIM IS MADE TO THE EXCLUSIVE RIGHT TO USE "TOTS", APART FROM THE MARK AS SHOWN.

FOR ONLINE RETAIL STORE SERVICES FEATURING INFANT AND CHILD PRODUCTS (U.S. CLS. 100, 101 AND 102).

FIRST USE 12-15-2005; IN COMMERCE 12-15-2005.
PAUL MORENO, EXAMINING ATTORNEY

SN 85-180,237. IMMIGRANT INVESTORS ASSOCIATION, INC., DBA ASSOCIATION TO INVEST IN THE USA (IIUSA), CHICAGO, IL. FILED 11-18-2010.

IIUSA

THE MARK CONSISTS OF STANDARD CHARACTERS WITHOUT CLAIM TO ANY PARTICULAR FONT, STYLE, SIZE, OR COLOR.

FOR TRADE ASSOCIATION SERVICES, NAMELY, PROMOTING THE BUSINESS MANAGEMENT INTERESTS OF REGIONAL IMMIGRATION CENTERS THAT MUST COMPLY WITH FEDERAL REGULATIONS (U.S. CLS. 100, 101 AND 102).

FIRST USE 11-30-2007; IN COMMERCE 11-30-2007.
BERYL GARDNER, EXAMINING ATTORNEY

SN 85-180,261. IMMIGRANT INVESTORS ASSOCIATION, INC., DBA ASSOCIATION TO INVEST IN THE USA (IIUSA), CHICAGO, IL. FILED 11-18-2010.



NO CLAIM IS MADE TO THE EXCLUSIVE RIGHT TO USE "ASSOCIATION TO INVEST IN USA", APART FROM THE MARK AS SHOWN.

THE MARK CONSISTS OF THE STYLIZED WORDING "IIUSA" SEPARATED BY AN ANGLE FROM THE STYLIZED WORDING "ASSOCIATION TO INVEST IN USA" ALL INSIDE A SHADED RECTANGLE.

FOR TRADE ASSOCIATION SERVICES, NAMELY, PROMOTING THE BUSINESS MANAGEMENT INTERESTS OF REGIONAL IMMIGRATION CENTERS THAT MUST COMPLY WITH FEDERAL REGULATIONS (U.S. CLS. 100, 101 AND 102).

FIRST USE 11-30-2007; IN COMMERCE 11-30-2007.
BERYL GARDNER, EXAMINING ATTORNEY

CLASS 35—(Continued).

SN 85-181,625. MAC AND CO., SEATTLE, WA. FILED 11-19-2010.

MACRINA

THE MARK CONSISTS OF STANDARD CHARACTERS WITHOUT CLAIM TO ANY PARTICULAR FONT, STYLE, SIZE, OR COLOR.

SEC. 2(F).

FOR TAKE-OUT BAKERY SERVICES (U.S. CLS. 100, 101 AND 102).

FIRST USE 8-1-1993; IN COMMERCE 8-1-1993.

BRENDAN REGAN, EXAMINING ATTORNEY

SN 85-190,637. COMVERGE, INC., NORCROSS, GA. FILED 12-3-2010.

IntelliMEASURE

THE MARK CONSISTS OF STANDARD CHARACTERS WITHOUT CLAIM TO ANY PARTICULAR FONT, STYLE, SIZE, OR COLOR.

FOR ENERGY USAGE MANAGEMENT; LOAD MANAGEMENT SERVICES, NAMELY, CONTROLLING ENERGY USAGE AND A WORKING PROGRAM FOR DELIVERING THE SYSTEM OPERATIONS OF SUCH ENERGY MANAGEMENT DEVICES VIA A SWITCH, THERMOSTAT, OR ENERGY MANAGEMENT CONTROLLER LOCATED AT THE END CUSTOMER'S PREMISES; UTILITY BILL MANAGEMENT SERVICES, NAMELY, TRACKING, REPORTING, ANALYZING AND DELIVERING ENERGY INFORMATION IN THE FORM OF THERMOSTAT DISPLAYS, WEB PAGES, OR MAILINGS; MANAGEMENT OF ENERGY DATA, CUSTOMER DATA AND THEIR ENERGY USAGE, NAMELY, MEASUREMENT OR VERIFICATION OF ENERGY USAGE; BUSINESS CONSULTING, MANAGEMENT, PLANNING AND SUPERVISION IN THE FIELD OF ENERGY; INFORMATION AND DATA COMPILING AND ANALYZING RELATING TO BUSINESS MANAGEMENT (U.S. CLS. 100, 101 AND 102).

FIRST USE 10-18-2010; IN COMMERCE 10-18-2010.

KATHY DE JONGE, EXAMINING ATTORNEY

CLASS 35—(Continued).

SN 85-192,584. COMVERGE, INC., NORCROSS, GA. FILED 12-7-2010.

IntelliMARKET

THE MARK CONSISTS OF STANDARD CHARACTERS WITHOUT CLAIM TO ANY PARTICULAR FONT, STYLE, SIZE, OR COLOR.

FOR ENERGY USAGE MANAGEMENT; LOAD MANAGEMENT SERVICES, NAMELY, ASSISTING IN THE RECRUITMENT OF END CUSTOMERS WHO ALLOW CONTROL OF ENERGY USAGE AND PARTICIPATE IN PROGRAMS FOR DELIVERING THE SYSTEM OPERATIONS OF SUCH ENERGY MANAGEMENT DEVICES VIA A SWITCH, THERMOSTAT, OR ENERGY MANAGEMENT CONTROLLER LOCATED AT THE END CUSTOMER'S PREMISES; UTILITY BILL MANAGEMENT SERVICES, NAMELY, TRACKING, REPORTING, ANALYZING AND DELIVERING ENERGY INFORMATION IN THE FORM OF THERMOSTAT DISPLAYS, WEB PAGES, OR MAILINGS; MANAGEMENT OF ENERGY DATA, CUSTOMER DATA AND THEIR ENERGY USAGE, NAMELY, MEASUREMENT OR VERIFICATION OF ENERGY USAGE; BUSINESS CONSULTING, MANAGEMENT, PLANNING AND SUPERVISION IN THE FIELD OF ENERGY; INFORMATION AND DATA COMPILING AND ANALYZING RELATING TO BUSINESS MANAGEMENT (U.S. CLS. 100, 101 AND 102).

FIRST USE 10-18-2010; IN COMMERCE 10-18-2010.

KATHY DE JONGE, EXAMINING ATTORNEY

SN 85-194,178. MORGAN STANLEY, NEW YORK, NY. FILED 12-9-2010.

MORGAN STANLEY CIRCA INDEX

THE MARK CONSISTS OF STANDARD CHARACTERS WITHOUT CLAIM TO ANY PARTICULAR FONT, STYLE, SIZE, OR COLOR.

OWNER OF U.S. REG. NOS. 1,707,196, 2,995,473 AND OTHERS.

NO CLAIM IS MADE TO THE EXCLUSIVE RIGHT TO USE "INDEX", APART FROM THE MARK AS SHOWN.

FOR FINANCIAL SERVICES, NAMELY, PROVIDING FINANCIAL DATA IN THE NATURE OF FINANCIAL INDICES (U.S. CLS. 100, 101 AND 102).

TINA MAI, EXAMINING ATTORNEY

CLASS 35—(Continued).

SN 85-199,827. THE FAMILY BUSINESS CONSULTING GROUP, INC., MARIETTA, GA. FILED 12-16-2010.

BEYOND BEST PRACTICES

THE MARK CONSISTS OF STANDARD CHARACTERS WITHOUT CLAIM TO ANY PARTICULAR FONT, STYLE, SIZE, OR COLOR.

NO CLAIM IS MADE TO THE EXCLUSIVE RIGHT TO USE "BEST PRACTICES", APART FROM THE MARK AS SHOWN.

FOR BUSINESS CONSULTING SERVICES, NAMELY, ADVISING FAMILY BUSINESSES ON HOW TO SUSTAIN THEIR OPERATIONS ACROSS GENERATIONAL LINES (U.S. CLS. 100, 101 AND 102).

CURTIS FRENCH, EXAMINING ATTORNEY

SN 85-200,883. NAGANO TECTRON CO., LTD., NAGANO 388-8014, JAPAN, FILED 12-17-2010.



NO CLAIM IS MADE TO THE EXCLUSIVE RIGHT TO USE "RETRIEVAL OF GOURMET AROUND HOTEL", APART FROM THE MARK AS SHOWN.

THE MARK CONSISTS OF SETTINGS OF FLATWARE WITH PLATES; STYLIZED WORD FOR "HOTEGURU" AND "RETRIEVAL OF GOURMET AROUND HOTEL".

FOR ONLINE ADVERTISEMENT ON THE COMPUTER NETWORK; PROVIDING A WEB SITE WHICH FEATURES ADVERTISEMENTS FOR THE GOODS AND SERVICES OF OTHERS ON A GLOBAL COMPUTER NETWORK; ADVERTISING PROMOTING THE GOODS AND SERVICES OF OTHERS USING COMPUTER KIOSKS AND INTERACTIVE KIOSKS; ADVERTISING PROMOTING STORES, SHOPS, AND RESTAURANTS AROUND HOTELS USING COMPUTERS SET UP IN THE HOTELS; ADVERTISEMENTS FOR OTHERS THROUGH ELECTRONIC MEDIA AND THE INTERNET (U.S. CLS. 100, 101 AND 102).

PAUL E. FAHRENKOPF, EXAMINING ATTORNEY

CLASS 35—(Continued).

SN 85-203,447. CHRISTCOT MEDICAL COMPANY, SUD-BURY, MA. FILED S.R. 12-21-2010; AM. P.R. 6-8-2011.



NO CLAIM IS MADE TO THE EXCLUSIVE RIGHT TO USE "MEDICAL COMPANY", APART FROM THE MARK AS SHOWN.

THE COLOR(S) WHITE, GREY AND MIDNIGHT BLUE IS/ARE CLAIMED AS A FEATURE OF THE MARK.

THE MARK CONSISTS OF A GREY CIRCLE WITH A VERTICAL, PIE SHAPED CUT OUT AT THE TOP CULMINATING IN A WHITE SPRITE IN THE CENTER OF THE CIRCLE. THE GREY CIRCLE IS SURROUNDED BY MIDNIGHT BLUE CRESCENTS ON EITHER SIDE. THE RIGHT, SMALLER, CRESCENT FITS WITHIN THE LEFT CRESCENT. TO THE RIGHT OF THE MARK "CHRISTCOT" APPEARS IN MIDNIGHT BLUE, BENEATH "CHRISTCOT" AND STARTING UNDER THE LETTER "H", "MEDICAL COMPANY" APPEARS IN GREY.

FOR DISTRIBUTORSHIPS IN THE FIELD OF MEDICAL SUPPLIES AND RELATED GOODS (U.S. CLS. 100, 101 AND 102).

FIRST USE 10-13-2008; IN COMMERCE 3-16-2010.

JESSICA A. POWERS, EXAMINING ATTORNEY

SN 85-204,548. THE AMERICAN NATURAL GAS ALLIANCE, INC., WASHINGTON, DC. FILED 12-22-2010.

SMARTER POWER TODAY

THE MARK CONSISTS OF STANDARD CHARACTERS WITHOUT CLAIM TO ANY PARTICULAR FONT, STYLE, SIZE, OR COLOR.

FOR ASSOCIATION SERVICES, NAMELY, PROMOTING THE PUBLIC INTERESTS AND AWARENESS IN THE BENEFITS OF NATURAL GAS; ADVERTISING SERVICES, NAMELY, DEVELOPING AND DISSEMINATING PRINTED AND ONLINE PROMOTIONAL OR ADVERTISING MATERIALS IN THE FIELD OF NATURAL GAS (U.S. CLS. 100, 101 AND 102).

ANDREA K. NADELMAN, EXAMINING ATTORNEY

CLASS 35—(Continued).

SN 85-205,281. GO FISH INC., FANNY BAY, BC, CANADA, FILED 12-23-2010.

CLASS 35—(Continued).

SN 85-206,033. CATHERINES OF CALIFORNIA, INC., LOS ANGELES, CA. FILED 12-27-2010.

ZONE OF UNCERTAINTY

THE MARK CONSISTS OF STANDARD CHARACTERS WITHOUT CLAIM TO ANY PARTICULAR FONT, STYLE, SIZE, OR COLOR.

PRIORITY CLAIMED UNDER SEC. 44(D) ON CANADA APPLICATION NO. 1488165, FILED 7-9-2010, REG. NO. TMA801,930, DATED 7-11-2011, EXPIRES 7-11-2026.

FOR BUSINESS RISK MANAGEMENT CONSULTING SERVICES (U.S. CLS. 100, 101 AND 102).

GIANCARLO CASTRO, EXAMINING ATTORNEY

SN 85-206,012. CATHERINES OF CALIFORNIA, INC., LOS ANGELES, CA. FILED 12-27-2010.

SUPREMA BY CATHERINES

THE MARK CONSISTS OF STANDARD CHARACTERS WITHOUT CLAIM TO ANY PARTICULAR FONT, STYLE, SIZE, OR COLOR.

OWNER OF U.S. REG. NOS. 1,343,457, 3,006,871 AND 3,345,802.

THE NAME(S), PORTRAIT(S), AND/OR SIGNATURE(S) SHOWN IN THE MARK DOES NOT IDENTIFY A PARTICULAR LIVING INDIVIDUAL.

FOR RETAIL STORE SERVICES FEATURING WOMEN'S WEARING APPAREL AND ACCESSORIES; COMPUTERIZED ON-LINE RETAIL STORE SERVICES FEATURING WOMEN'S WEARING APPAREL AND ACCESSORIES; DISSEMINATION OF THE PRINT ADVERTISING MATTER OF OTHERS; MAIL ORDER CATALOG SERVICES FEATURING WOMEN'S WEARING APPAREL AND ACCESSORIES; ADVERTISING SERVICE TO DISTRIBUTE ADVERTISEMENTS FOR DISPLAY ON INTERNET, NAMELY, IN WEBSITES, SOCIAL CONVERSATIONS OVER THE INTERNET, EMAILS, MICROBLOGS, BLOGS, ELECTRONIC MESSAGES, INSTANT MESSAGES, TEXT MESSAGES, MULTIMEDIA MESSAGES, SOCIAL NETWORKS, STATUS UPDATES, FORUMS, ELECTRONIC BULLETIN BOARDS (U.S. CLS. 100, 101 AND 102).

GISELLE AGOSTO, EXAMINING ATTORNEY

SOFTNESS HAS A NEW NAME

THE MARK CONSISTS OF STANDARD CHARACTERS WITHOUT CLAIM TO ANY PARTICULAR FONT, STYLE, SIZE, OR COLOR.

FOR RETAIL STORE SERVICES FEATURING WOMEN'S WEARING APPAREL AND ACCESSORIES; COMPUTERIZED ON-LINE RETAIL STORE SERVICES FEATURING WOMEN'S WEARING APPAREL AND ACCESSORIES; DISSEMINATION OF THE PRINT ADVERTISING MATTER OF OTHERS; MAIL ORDER CATALOG SERVICES FEATURING WOMEN'S WEARING APPAREL AND ACCESSORIES; ADVERTISING SERVICE TO DISTRIBUTE ADVERTISEMENTS FOR DISPLAY ON INTERNET, NAMELY, IN WEBSITES, SOCIAL CONVERSATIONS OVER THE INTERNET, EMAILS, MICROBLOGS, BLOGS, ELECTRONIC MESSAGES, INSTANT MESSAGES, TEXT MESSAGES, MULTIMEDIA MESSAGES, SOCIAL NETWORKS, STATUS UPDATES, FORUMS, ELECTRONIC BULLETIN BOARDS (U.S. CLS. 100, 101 AND 102).

GISELLE AGOSTO, EXAMINING ATTORNEY

SN 85-211,057. DISTRICT SPORTS, WASHINGTON, DC. FILED 1-5-2011.

DISTRICT SPORTS

THE MARK CONSISTS OF STANDARD CHARACTERS WITHOUT CLAIM TO ANY PARTICULAR FONT, STYLE, SIZE, OR COLOR.

NO CLAIM IS MADE TO THE EXCLUSIVE RIGHT TO USE "SPORTS", APART FROM THE MARK AS SHOWN. SEC. 2(F).

FOR PROVIDING ON-LINE REGISTRATION SERVICES FOR SPORTS TEAMS, LEAGUES AND INDIVIDUALS; ADMINISTRATION OF RECREATIONAL SPORTS LEAGUES AND TEAMS; COORDINATION OF RECREATIONAL SPORTING OPPORTUNITIES FOR INDIVIDUALS WHO WISH TO PARTICIPATE IN TEAM LEAGUE SPORTS; AND PROVIDING A WEBSITE THAT PROVIDES SPORTS LEAGUE MANAGEMENT (U.S. CLS. 100, 101 AND 102).

FIRST USE 9-0-2004; IN COMMERCE 9-0-2004.
AMY KERTGATE, EXAMINING ATTORNEY

CLASS 35—(Continued).

SN 85-211,600. STATE FARM MUTUAL AUTOMOBILE INSURANCE COMPANY, BLOOMINGTON, IL. FILED 1-6-2011.

Not Now. I'm Driving.

THE MARK CONSISTS OF STANDARD CHARACTERS WITHOUT CLAIM TO ANY PARTICULAR FONT, STYLE, SIZE, OR COLOR.

FOR PROMOTING PUBLIC AWARENESS OF THE DANGER OF TEXTING AND DRIVING AMONGST TEEN DRIVERS (U.S. CLS. 100, 101 AND 102).

DAVID ELTON, EXAMINING ATTORNEY

SN 85-218,670. KARMASU TECHNOLOGY INC., VANCOUVER, CANADA, FILED 1-15-2011.

BOMBAY BAGS

THE MARK CONSISTS OF STANDARD CHARACTERS WITHOUT CLAIM TO ANY PARTICULAR FONT, STYLE, SIZE, OR COLOR.

OWNER OF CANADA REG. NO. TMA797,434, DATED 5-12-2011, EXPIRES 5-12-2026.

NO CLAIM IS MADE TO THE EXCLUSIVE RIGHT TO USE "BAGS", APART FROM THE MARK AS SHOWN.

FOR ON-LINE RETAIL STORE SERVICES FEATURING BAGS, CLOTHING, FASHION ACCESSORIES AND STATIONERY (U.S. CLS. 100, 101 AND 102).

LINDA M. KING, EXAMINING ATTORNEY

CLASS 35—(Continued).

SN 85-218,758. MLBC, INC, DBA WWW.MEETLOCALBIZ.COM, COLUMBIA, MD. FILED 1-16-2011.

Weekly ^{Local} Deals

NO CLAIM IS MADE TO THE EXCLUSIVE RIGHT TO USE "WEEKLY LOCAL DEALS", APART FROM THE MARK AS SHOWN.

THE COLOR(S) BLACK, RED IS/ARE CLAIMED AS A FEATURE OF THE MARK.

THE MARK CONSISTS OF THE WORDS "WEEKLY LOCAL DEALS"; "WEEKLY" IN BLACK COLOR, "LOCAL" WRITTEN IN CHALK STYLE LETTERS FONT INCLUDING ARROW HEAD IN RED COLOR OVER "WEEKLY DEALS" AND IN BETWEEN THE WORDS "WEEKLY DEALS", "DEALS" IN BLACK COLOR.

FOR AD SERVING, NAMELY, PLACING ADVERTISEMENTS ON WEBSITES FOR OTHERS USING SPECIALIZED COMPUTER SOFTWARE; ADVERTISEMENT AND PUBLICITY SERVICES BY TELEVISION, RADIO, MAIL; ADVERTISEMENT FOR OTHERS ON THE INTERNET; ADVERTISEMENT VIA MOBILE PHONE NETWORKS; ADVERTISING AGENCIES PROVIDING THE STRATEGY, DESIGN AND EXECUTION OF PROGRAMS TO PROMOTE BUSINESSES IN THE FOOD AND FOODSERVICE INDUSTRIES; ADVERTISING AGENCIES, NAMELY, PROMOTING THE GOODS AND SERVICES OF OTHERS; ADVERTISING AGENCY SPECIALIZING IN THE DESIGN AND EXECUTION OF WORD OF MOUTH, VIRAL, BUZZ AND EXPERIENTIAL MARKETING PROGRAMS; ADVERTISING AND ADVERTISEMENT SERVICES; ADVERTISING AND BUSINESS SERVICES, NAMELY, PROVIDING AN ONLINE WEBSITE WHERE ADVERTISERS, MARKETERS, AND CONTENT PROVIDERS CAN INTERACT WITH USERS FOR ADVERTISING, BRANDING, AND PROMOTING KNOWLEDGE, PRODUCTS, AND SERVICES, AND TRADESHOWS, ON BEHALF OF THEMSELVES AND OTHERS, AND FOR EVALUATING AND RATING THE SAME, ALL THE FOREGOING RELEVANT TO HUMAN ACTIVITIES AFFECTING CLIMATE CHANGE AND RELATED FIELDS; ADVERTISING AND COMMERCIAL INFORMATION SERVICES, VIA THE INTERNET; ADVERTISING AND DIRECTORY SERVICES, NAMELY, PROMOTING THE SERVICES OF OTHERS BY PROVIDING A WEB PAGE FEATURING LINKS TO THE WEBSITES OF OTHERS; ADVERTISING AND MARKETING SERVICES PROVIDED BY MEANS OF INDIRECT METHODS OF MARKETING COMMUNICATIONS, NAMELY, SOCIAL MEDIA, SEARCH ENGINE MARKETING, INQUIRY MARKETING, INTERNET MARKETING, MOBILE MARKETING, BLOGGING AND OTHER FORMS OF PASSIVE, SHARABLE OR VIRAL COMMUNICATIONS CHANNELS; ADVERTISING AND MARKETING SERVICES, NAMELY, PROMOTING THE GOODS AND SERVICES OF OTHERS; ADVERTISING ON THE INTERNET FOR OTHERS (U.S. CLS. 100, 101 AND 102).

FIRST USE 10-6-2010; IN COMMERCE 11-24-2010.

KRISTIN CARLSON, EXAMINING ATTORNEY

CLASS 35—(Continued).

SN 85-222,176. TRAKLOK CORPORATION, KNOXVILLE, TN. FILED 1-20-2011.



NO CLAIM IS MADE TO THE EXCLUSIVE RIGHT TO USE "CORPORATION," AND "WORLDWIDE TRACKING, WORLD CLASS SECURITY", APART FROM THE MARK AS SHOWN.

THE MARK CONSISTS OF THE TERMS "TRAKLOK", "CORPORATION", AND "WORLDWIDE TRACKING WORLD CLASS SECURITY" IN A SUBSTANTIALLY STACKED CONFIGURATION ADJACENT AN IMAGE OF A CIRCLE DEFINED IN PART BY SUBSTANTIALLY PARALLEL ANGLED LINES WITH TWO ARCHES APPEARING TO ENCIRCLE THE IMAGE OF THE CIRCLE AT DIFFERENT ANGLES.

FOR PROVIDING TRACKING SERVICES AND INFORMATION CONCERNING TRACKING OF INTERMODAL SHIPPING CONTAINERS; PROVIDING A WEBSITE FEATURING TRACKING SERVICES AND LOCATION INFORMATION FOR THE TRACKING OF INTERMODAL SHIPPING CONTAINERS (U.S. CLS. 100, 101 AND 102).

FIRST USE 7-31-2009; IN COMMERCE 7-31-2009.
ALICE BENMAMAN, EXAMINING ATTORNEY

CLASS 35—(Continued).

SN 85-232,037. THE ANNUITY STORE FINANCIAL & INSURANCE SERVICES, LLC, SACRAMENTO, CA. FILED 2-2-2011.

SUCCESS MADE SIMPLE

THE MARK CONSISTS OF STANDARD CHARACTERS WITHOUT CLAIM TO ANY PARTICULAR FONT, STYLE, SIZE, OR COLOR.

FOR PROVIDING MARKETING SERVICES TO INSURANCE AGENTS IN THE FIELDS OF ANNUITIES, LIFE INSURANCE, AND LONG TERM CARE INSURANCE (U.S. CLS. 100, 101 AND 102).

KATHERINE CHANG, EXAMINING ATTORNEY

SN 85-232,225. MASK, LINDSEY, ARLINGTON, VA. FILED 2-2-2011.

SN 85-227,908. AGDATA, L.P., CHARLOTTE, NC. FILED 1-27-2011.



DIRECTIONS RESEARCH

THE MARK CONSISTS OF STANDARD CHARACTERS WITHOUT CLAIM TO ANY PARTICULAR FONT, STYLE, SIZE, OR COLOR.

NO CLAIM IS MADE TO THE EXCLUSIVE RIGHT TO USE "RESEARCH", APART FROM THE MARK AS SHOWN. FOR AGRICULTURAL MARKET RESEARCH (U.S. CLS. 100, 101 AND 102).

FIRST USE 0-0-1983; IN COMMERCE 0-0-1983.
DOMINIC J. FERRAIUOLO, EXAMINING ATTORNEY

NO CLAIM IS MADE TO THE EXCLUSIVE RIGHT TO USE "LADIES DC", APART FROM THE MARK AS SHOWN. THE STIPPLING IS FOR SHADING PURPOSES ONLY.

THE MARK CONSISTS OF A CIRCLE DESIGN CONTAINING A RAY PATTERN AND AN OUTLINE OF THE DOME OF THE US CAPITOL BUILDING. THE OUTLINE OF THE DOME SITS ABOVE THE WORD "LADIES DC", AND TO THE LEFT OF A DESIGN OF THE WASHINGTON MONUMENT. TO THE LEFT OF THE CIRCULAR DESIGN IS THE SILHOUETTE OF A FEMALE HOLDING A BOOK.

FOR ASSOCIATION SERVICES, NAMELY, PROMOTING THE INTERESTS OF PROFESSIONAL WOMEN IN THE DISTRICT OF COLUMBIA METROPOLITAN REGION (U.S. CLS. 100, 101 AND 102).

JANICE L. MCMORROW, EXAMINING ATTORNEY

CLASS 35—(Continued).

SN 85-232,938. ELKHART GENERAL HOSPITAL, INC., ELKHART, IN. FILED 2-3-2011.



THE MARK CONSISTS OF THE WORDS "DAME TU MANO" UNDERNEATH A HALF CIRCLE AND TWO HANDS.

THE ENGLISH TRANSLATION OF "DAME TU MANO" IN THE MARK IS "GIVE ME YOUR HAND".

FOR PROMOTING HEALTH AWARENESS AND HEALTHY LIFESTYLES (U.S. CLS. 100, 101 AND 102).

FIRST USE 8-11-2007; IN COMMERCE 8-28-2007.
TIMOTHY FINNEGAN, EXAMINING ATTORNEY

SN 85-235,479. AMES, LISA, LOS ANGELES, CA. AND AMES, MARK, LOS ANGELES, CA. FILED 2-7-2011.

Art Meets Architecture

THE MARK CONSISTS OF STANDARD CHARACTERS WITHOUT CLAIM TO ANY PARTICULAR FONT, STYLE, SIZE, OR COLOR.

NO CLAIM IS MADE TO THE EXCLUSIVE RIGHT TO USE "ART" AND "ARCHITECTURE", APART FROM THE MARK AS SHOWN.

FOR ARRANGING AND CONDUCTING TRADE SHOW EXHIBITIONS IN THE FIELD OF ART; ART GALLERIES; ART GALLERY SERVICES (U.S. CLS. 100, 101 AND 102).

FIRST USE 9-25-2010; IN COMMERCE 12-9-2010.
GRETTA YAO, EXAMINING ATTORNEY

CLASS 35—(Continued).

SN 85-235,816. REVCO ELECTRICAL SUPPLY, INC., SOUTHAMPTON, NY. FILED 2-7-2011.



NO CLAIM IS MADE TO THE EXCLUSIVE RIGHT TO USE "INC. LIGHTING AND ELECTRICAL SUPPLY", APART FROM THE MARK AS SHOWN.

THE MARK CONSISTS OF THE STYLIZED WORDING "REVCO INC." ABOVE THE STYLIZED WORDING "LIGHTING + ELECTRICAL SUPPLY", WHERE THE WORDING "INC." IS INSIDE THE LETTER "C" OF "REVCO".

FOR DISTRIBUTION SERVICES, NAMELY, DISTRIBUTORSHIPS IN THE FIELD OF ELECTRIC LIGHTING AND LIGHTING SUPPLIES; RETAIL STORE SERVICES FEATURING ELECTRIC LIGHTING AND LIGHTING SUPPLIES (U.S. CLS. 100, 101 AND 102).

JAY BESCH, EXAMINING ATTORNEY

SN 85-236,240. SANTA CLARITA TRACK CLUB, INC., SANTA CLARITA, CA. FILED 2-8-2011.

Students Off And Running SOAR Santa Clarita

THE MARK CONSISTS OF STANDARD CHARACTERS WITHOUT CLAIM TO ANY PARTICULAR FONT, STYLE, SIZE, OR COLOR.

NO CLAIM IS MADE TO THE EXCLUSIVE RIGHT TO USE "SANTA CLARITA", APART FROM THE MARK AS SHOWN.

FOR CHARITABLE SERVICES, NAMELY, ORGANIZING YOUTH GROUPS TO UNDERTAKE PROJECTS TO BENEFIT THE NEEDY AND THE COMMUNITY TO ENCOURAGE LEADERSHIP, CHARACTER, COMPASSION, AND GOOD CITIZENSHIP; CLUB SERVICES, NAMELY, PROMOTING THE INTERESTS OF MARATHON RUNNING FOR AT RISK HIGH SCHOOL STUDENTS (U.S. CLS. 100, 101 AND 102).

FIRST USE 6-15-2006; IN COMMERCE 6-15-2006.
BILL DAWE, EXAMINING ATTORNEY

CLASS 35—(Continued).

SN 85-236,893. BUSINESS TRANSITIONS, LLC, DBA FP TRANSITIONS, LAKE OSWEGO, OR. FILED 2-8-2011.

TeamBuilder

THE MARK CONSISTS OF STANDARD CHARACTERS WITHOUT CLAIM TO ANY PARTICULAR FONT, STYLE, SIZE, OR COLOR.

FOR BUSINESS CONSULTATION IN THE FIELD OF BUSINESS ENTITY FORMATION; BUSINESS CONSULTING SERVICES IN THE FIELD OF CONTINUITY AND SUCCESSION PLANNING; BUSINESS MANAGEMENT SERVICES, NAMELY, PURCHASING OF AND SELLING OF COMPANIES FOR OTHERS; BUSINESS MANAGEMENT CONSULTANCY IN THE FIELD OF PURCHASES, NAMELY, ASSISTING BUSINESSES IN IMPROVEMENT OF PURCHASING FUNCTIONS; BUSINESS CONSULTATION SERVICES IN THE FIELD OF TRANSITIONING NEW MANAGEMENT TEAMS INTO EXISTING BUSINESSES (U.S. CLS. 100, 101 AND 102).

KIM SAITO, EXAMINING ATTORNEY

SN 85-238,410. SIKES, INC., COLLEGE STATION, TX. FILED 2-9-2011.

JUNK GYPSY

THE MARK CONSISTS OF STANDARD CHARACTERS WITHOUT CLAIM TO ANY PARTICULAR FONT, STYLE, SIZE, OR COLOR.

OWNER OF U.S. REG. NO. 2,814,108.

NO CLAIM IS MADE TO THE EXCLUSIVE RIGHT TO USE "JUNK", APART FROM THE MARK AS SHOWN.

FOR ORGANIZING, PROMOTING AND CONDUCTING EXHIBITIONS, EVENTS, TRADESHOWS FOR BUSINESS PURPOSES FEATURING ANTIQUES, FURNITURE, AND COLLECTIBLES; RETAIL STORE SERVICES FEATURING ANTIQUES AND COLLECTIBLES FOR HOME AND OFFICE USE; ON-LINE RETAIL STORE SERVICES FEATURING ANTIQUES AND COLLECTIBLES FOR HOME AND OFFICE USE; BUYING CLUB SERVICES FEATURING ANTIQUES AND COLLECTIBLES FOR OTHERS FOR HOME AND OFFICE USE (U.S. CLS. 100, 101 AND 102).

FIRST USE 10-1-2000; IN COMMERCE 10-1-2000.

FLORENTINA BLANDU, EXAMINING ATTORNEY

SN 85-239,042. HEALTHED ACADEMY, LLC, CLARK, NJ. FILED 2-10-2011.

SURROUNDHEALTH

THE MARK CONSISTS OF STANDARD CHARACTERS WITHOUT CLAIM TO ANY PARTICULAR FONT, STYLE, SIZE, OR COLOR.

FOR ONLINE PROFESSIONAL NETWORKING SERVICES FOR PEOPLE IN THE HEALTH EDUCATION PROFESSION (U.S. CLS. 100, 101 AND 102).

FIRST USE 4-26-2011; IN COMMERCE 4-26-2011.

JENNIFER MARTIN, EXAMINING ATTORNEY

CLASS 35—(Continued).

SN 85-239,171. HOMEWISE REFERRALS, INC., ALEXANDRIA, VA. FILED 2-10-2011.



NO CLAIM IS MADE TO THE EXCLUSIVE RIGHT TO USE "REFERRALS, INC.", APART FROM THE MARK AS SHOWN.

THE MARK CONSISTS OF THE WORDING "HOMEWISE REFERRALS, INC." WITH THE DESIGN OF AN OWL SITTING ON THE CHIMNEY OF A ROOFTOP.

FOR PROVIDING REFERRALS IN THE FIELD OF HOME RENOVATIONS, REPAIRS AND IMPROVEMENTS (U.S. CLS. 100, 101 AND 102).

FIRST USE 1-18-2011; IN COMMERCE 1-18-2011.

MELISSA VALLILLO, EXAMINING ATTORNEY

SN 85-239,920. MB COMPUTER SYSTEMS LLC, COMMACK, NY. FILED 2-11-2011.



NO CLAIM IS MADE TO THE EXCLUSIVE RIGHT TO USE "COMPUTER SYSTEMS", APART FROM THE MARK AS SHOWN.

THE COLOR(S) LIGHT BLUE, BLUE, DARK BLUE, AND WHITE IS/ARE CLAIMED AS A FEATURE OF THE MARK.

THE MARK CONSISTS OF THE STYLIZED BLUE, LIGHT BLUE, AND DARK BLUE LETTERS "MB" ABOVE THE STYLIZED LIGHT BLUE WORDING "COMPUTER SYSTEMS" SURROUNDED BY A BROKEN BLUE AND DARK BLUE CYLINDER ALL ON A WHITE BACKGROUND.

FOR RETAIL STORE SERVICES FEATURING DESKTOP COMPUTERS (U.S. CLS. 100, 101 AND 102).

DAVID TOOLEY, EXAMINING ATTORNEY

CLASS 35—(Continued).

SN 85-241,008. WRIGHT SIMONE, PHILADELPHIA, PA.
FILED S.R. 2-13-2011; AM. P.R. 7-14-2011.

Beauty Coliseum

THE MARK CONSISTS OF STANDARD CHARACTERS WITHOUT CLAIM TO ANY PARTICULAR FONT, STYLE, SIZE, OR COLOR.

NO CLAIM IS MADE TO THE EXCLUSIVE RIGHT TO USE "BEAUTY", APART FROM THE MARK AS SHOWN.

FOR RETAIL STORE SERVICES FEATURING HAIR CARE PRODUCTS AND COSMETICS (U.S. CLS. 100, 101 AND 102).

FIRST USE 1-1-2002; IN COMMERCE 1-1-2004.
EDWARD FENNESSY, EXAMINING ATTORNEY

SN 85-241,825. FRANCE PUBLICATIONS, INC., ATLANTA, GA. FILED 2-14-2011.

THE GOLDBOOK OF STUDENT HOUSING

THE MARK CONSISTS OF STANDARD CHARACTERS WITHOUT CLAIM TO ANY PARTICULAR FONT, STYLE, SIZE, OR COLOR.

NO CLAIM IS MADE TO THE EXCLUSIVE RIGHT TO USE STUDENT HOUSING, APART FROM THE MARK AS SHOWN.

FOR PROVIDING AN ON-LINE DIRECTORY INFORMATION SERVICE FEATURING INFORMATION REGARDING OWNERSHIP, OPERATING AND MANAGEMENT COMPANIES IN THE STUDENT HOUSING REAL ESTATE INDUSTRY AS WELL AS SERVICE PROVIDERS RELATED TO STUDENT HOUSING PROPERTIES (U.S. CLS. 100, 101 AND 102).

KYLE PEETE, EXAMINING ATTORNEY

SN 85-244,109. FRIENDLY, ANA ZELEDON, LOS ANGELES, CA. FILED 2-16-2011.

FRIENDLY CONSULTING

THE MARK CONSISTS OF STANDARD CHARACTERS WITHOUT CLAIM TO ANY PARTICULAR FONT, STYLE, SIZE, OR COLOR.

NO CLAIM IS MADE TO THE EXCLUSIVE RIGHT TO USE "CONSULTING", APART FROM THE MARK AS SHOWN.

FOR BUSINESS CONSULTING SERVICES IN THE FIELDS OF PUBLIC HEALTH, HEALTHCARE AND NON-PROFIT ORGANIZATION MANAGEMENT (U.S. CLS. 100, 101 AND 102).

FIRST USE 2-0-2011; IN COMMERCE 2-0-2011.
TARA PATE, EXAMINING ATTORNEY

CLASS 35—(Continued).

SN 85-246,296. MAKE THE DAYS COUNT FOUNDATION, LOS ANGELES, CA. FILED 2-18-2011.



THE COLOR(S) RED, ORANGE, YELLOW, GREEN, BLUE, DARK BLUE, BLACK AND WHITE IS/ARE CLAIMED AS A FEATURE OF THE MARK.

THE MARK CONSISTS OF RAINBOW IN THE COLORS RED, ORANGE, YELLOW, GREEN, BLUE AND DARK BLUE AND TWO HUMAN HANDS HOLDING A BOY AND GIRL LOOKING UP AT THE RAINBOW AND THE HANDS AND CHILDREN ARE IN COLORS BLACK AND WHITE.

FOR CHARITABLE SERVICES, NAMELY, ORGANIZING AND CONDUCTING VOLUNTEER PROGRAMS AND COMMUNITY SERVICES (U.S. CLS. 100, 101 AND 102).

FIRST USE 1-1-2010; IN COMMERCE 0-0-2010.
EDWARD NELSON, EXAMINING ATTORNEY

SN 85-249,066. MILLER PUBLIC RELATIONS, COLLEYVILLE, TX. FILED 2-23-2011.

LIFESTYLE LENSES

THE MARK CONSISTS OF STANDARD CHARACTERS WITHOUT CLAIM TO ANY PARTICULAR FONT, STYLE, SIZE, OR COLOR.

FOR PROVIDING ADVERTISING, MARKETING AND PROMOTIONAL SERVICES, NAMELY, DEVELOPMENT OF ADVERTISING CAMPAIGNS PROVIDED THROUGH CABLE TELEVISION BROADCAST, WEB CASTS, RADIO BROADCASTS, NEWSPAPERS, MAGAZINES, ONLINE BANNERS, OUTDOOR BILLBOARDS, TABLE DRAPING, AND BROCHURES (U.S. CLS. 100, 101 AND 102).

ROBERT C. CLARK JR., EXAMINING ATTORNEY

CLASS 35—(Continued).

SN 85-249,194. EAST PENN MANUFACTURING CO., LYON STATION, PA. FILED 2-23-2011.

Power-Perform

THE MARK CONSISTS OF STANDARD CHARACTERS WITHOUT CLAIM TO ANY PARTICULAR FONT, STYLE, SIZE, OR COLOR.

FOR WHOLESALE DISTRIBUTORSHIPS FEATURING ELECTRIC STORAGE BATTERIES (U.S. CLS. 100, 101 AND 102).

CIMMERIAN COLEMAN, EXAMINING ATTORNEY

SN 85-249,297. DMT WEB VENTURES INC, SMITHTOWN, NY. FILED 2-23-2011.

TurboRoster

THE MARK CONSISTS OF STANDARD CHARACTERS WITHOUT CLAIM TO ANY PARTICULAR FONT, STYLE, SIZE, OR COLOR.

FOR PROVIDING AN ON-LINE PORTAL THAT CONNECTS USERS TO THE WEB SITES OF FITNESS CENTERS, CONTINUING EDUCATION SCHOOLS, EXERCISE STUDIOS, MARTIAL ARTS CLASSES, AND FITNESS AND EDUCATIONAL INSTITUTIONS IN ORDER TO ALLOW APPLICANT'S TO REGISTER FOR PROGRAMS (U.S. CLS. 100, 101 AND 102).

FIRST USE 5-1-2010; IN COMMERCE 8-31-2010.
DAVID C. REIHNER, EXAMINING ATTORNEY

SN 85-249,305. DMT WEB VENTURES INC, SMITHTOWN, NY. FILED 2-23-2011.

DirectRoster

THE MARK CONSISTS OF STANDARD CHARACTERS WITHOUT CLAIM TO ANY PARTICULAR FONT, STYLE, SIZE, OR COLOR.

FOR PROVIDING AN ON-LINE PORTAL THAT CONNECTS USERS TO THE WEB SITES OF FITNESS CENTERS, CONTINUING EDUCATION SCHOOLS, EXERCISE STUDIOS, MARTIAL ARTS CLASSES, AND FITNESS AND EDUCATIONAL INSTITUTIONS IN ORDER TO ALLOW APPLICANT'S TO REGISTER FOR PROGRAMS (U.S. CLS. 100, 101 AND 102).

FIRST USE 1-1-2011; IN COMMERCE 1-1-2011.
DAVID C. REIHNER, EXAMINING ATTORNEY

CLASS 35—(Continued).

SN 85-249,449. AMARÉ STOUDEMIRE ENTERPRISES, INC., WOODLAND HILLS, CA. FILED 2-23-2011.

AMARÉ STOUDEMIRE

THE MARK CONSISTS OF STANDARD CHARACTERS WITHOUT CLAIM TO ANY PARTICULAR FONT, STYLE, SIZE, OR COLOR.

THE NAME AMARE STOUDEMIRE IDENTIFIES A LIVING INDIVIDUAL WHOSE CONSENT IS OF RECORD.

FOR ADVERTISING SERVICES, NAMELY, PROMOTING THE BRANDS, GOODS AND SERVICES OF OTHERS; ENDORSEMENT SERVICES, NAMELY, PROMOTING THE GOODS AND SERVICES OF OTHERS (U.S. CLS. 100, 101 AND 102).

ALLISON HOLTZ, EXAMINING ATTORNEY

SN 85-250,350. THE MOMTREPNEUR EXCHANGE LLC, OAK PARK, IL. FILED 2-24-2011.

THE FOUNDING MOMS

THE MARK CONSISTS OF STANDARD CHARACTERS WITHOUT CLAIM TO ANY PARTICULAR FONT, STYLE, SIZE, OR COLOR.

NO CLAIM IS MADE TO THE EXCLUSIVE RIGHT TO USE "MOMS", APART FROM THE MARK AS SHOWN.

FOR BUSINESS SERVICES, NAMELY, PROMOTING THE INTERESTS OF ENTREPRENEURIAL WOMEN THROUGH IN PERSON AND ONLINE NETWORKING EVENTS RELATED TO BUSINESS, ENTREPRENEURSHIP AND MOTHERHOOD (U.S. CLS. 100, 101 AND 102).

FIRST USE 1-13-2011; IN COMMERCE 2-7-2011.
H. M. FISHER, EXAMINING ATTORNEY

CLASS 35—(Continued).

SN 85-251,362. BOOKER, JAMES, CHARLOTTE, NC. AND BOOKER, JULES, CHARLOTTE, NC. FILED 2-25-2011.



NO CLAIM IS MADE TO THE EXCLUSIVE RIGHT TO USE "ENTERTAINMENT", APART FROM THE MARK AS SHOWN.

THE MARK CONSISTS OF A SPACESHIP SLIGHTLY TILTED TO THE RIGHT ON A SHADED BACKGROUND WITH THE WORDS "SPACESHIP FLY ENTERTAINMENT" AND A SERIES OF STARS IN A RING AROUND THE CIRCUMFERENCE OF THE CIRCULAR MARK.

FOR ENTERTAINMENT ADMISSION VENUE CONTROL SERVICES, NAMELY, THE REMOTE VERIFICATION OF TICKET VALIDITY UPON PRESENTATION OF TICKETS AT AN ENTERTAINMENT VENUE; ENTERTAINMENT MARKETING SERVICES, NAMELY, MARKETING, PROMOTION AND ADVERTISING FOR INDEPENDENT RECORDING ARTISTS; ENTERTAINMENT MARKETING SERVICES, NAMELY, MARKETING, PROMOTION AND ADVERTISING FOR RECORDING AND PERFORMING ARTISTS; PERSONAL MANAGEMENT SERVICES FOR ENTERTAINERS; PROCUREMENT, NAMELY, PURCHASING TICKETS TO ENTERTAINMENT EVENTS FOR OTHERS; PROVIDING CONSUMER INFORMATION SERVICES AND MAKING REFERRALS IN THE FIELD OF ENTERTAINMENT SERVICES FOR PRODUCTS, SERVICES, EVENTS, ACTIVITIES, FACILITIES AND LOCATIONS (U.S. CLS. 100, 101 AND 102).

ANNE MADDEN, EXAMINING ATTORNEY

CLASS 35—(Continued).

SN 85-252,520. GRAND RAPIDS/KENT COUNTY CONVENTION & VISITORS BUREAU, DBA EXPERIENCE GRAND RAPIDS, GRAND RPAIDS, MI. FILED 2-26-2011.



NO CLAIM IS MADE TO THE EXCLUSIVE RIGHT TO USE "RESTAURANT WEEK GR", APART FROM THE MARK AS SHOWN.

THE COLOR(S) RED AND WHITE IS/ARE CLAIMED AS A FEATURE OF THE MARK.

THE MARK CONSISTS OF THE WORDS "RESTAURANT WEEK GR" IN PREDOMINANTLY WHITE LETTERS EXCEPT WITH THE LETTER "U" IN RED WITH A DEPICTION OF A CHEF'S HAT IN RED OVER IT AND THE LETTERS "GR" IN RED. THE BLACK COLORING IN THE MARK REPRESENTS THE BACKGROUND AND IS NOT CLAIMED AS A FEATURE OF THE MARK.

FOR PROMOTING THE RESTAURANT SERVICES OF OTHERS, NAMELY, A RECURRING PROMOTIONAL EVENT FOR RESTAURANTS IN THE GRAND RAPIDS METROPOLITAN AREA (U.S. CLS. 100, 101 AND 102).

FIRST USE 9-1-2010; IN COMMERCE 9-1-2010.
BARBARA BROWN, EXAMINING ATTORNEY

SN 85-253,286. RAM MANAGEMENT GROUP, INC., BEACHWOOD, OH. FILED 2-28-2011.



NO CLAIM IS MADE TO THE EXCLUSIVE RIGHT TO USE "SUPPLY CHAIN, LLC", APART FROM THE MARK AS SHOWN.

THE COLOR(S) DARK GREEN, BLUE IS/ARE CLAIMED AS A FEATURE OF THE MARK.

THE MARK CONSISTS OF THE STYLIZED WORDING "RAM SUPPLY CHAIN, LLC", WITH THE WORDING "RAM" APPEARING IN DARK GREEN WITH THE TOP THIRD OF EACH LETTER SEPARATED FROM THE BOTTOM TWO THIRDS BY A SPACE THAT IS OF A GENERALLY TRIANGULAR SHAPE ON THE LETTER "R" AND THAT RESEMBLES A STRAIGHT BAND ACROSS THE LETTERS "A" AND "M", AND WITH THE WORDING "SUPPLY CHAIN, LLC" APPEARING IN BLUE.

FOR BUSINESS CONSULTING SERVICES RELATING TO PRODUCT DISTRIBUTION, OPERATIONS MANAGEMENT SERVICES, LOGISTICS, REVERSE LOGISTICS, SUPPLY CHAIN, AND PRODUCTION SYSTEMS AND DISTRIBUTION SOLUTIONS; BUSINESS MANAGEMENT SERVICES, NAMELY, MANAGING LOGISTICS, REVERSE LOGISTICS, SUPPLY CHAIN SERVICES, SUPPLY CHAIN VISIBILITY AND SYNCHRONIZATION, SUPPLY AND DEMAND FORECASTING AND PRODUCT DISTRIBUTION PROCESSES FOR OTHERS (U.S. CLS. 100, 101 AND 102).

FIRST USE 9-27-1994; IN COMMERCE 9-27-1994.
CYNTHIA TRIPI, EXAMINING ATTORNEY

CLASS 35—(Continued).

SN 85-253,462. KIDSCAUSE, INC., FOLSOM, CA. FILED 2-28-2011.



NO CLAIM IS MADE TO THE EXCLUSIVE RIGHT TO USE ".COM", APART FROM THE MARK AS SHOWN.

THE MARK CONSISTS OF THE WORDS "KIDSCAUSE.COM" WITH A STYLIZED HUMAN FIGURE FORMING THE LETTER "K" AND PART OF THE LETTER "I", AND THE REMAINING LETTERS IN STYLIZED FORMAT, AND THE ".COM" APPEARING ABOVE THE LETTER "E". THERE IS A HORIZONTAL LINE ABOVE THE LETTERS "AUS".

FOR ADVERTISING AND PROMOTIONAL SERVICES; PROMOTING THE GOODS AND SERVICES OF OTHERS VIA A GLOBAL COMPUTER NETWORK; PROMOTING THE GOODS AND SERVICES OF OTHERS, NAMELY, PROVIDING INFORMATION REGARDING DISCOUNTS, COUPONS, REBATES, VOUCHERS, AND SPECIAL OFFERS FOR THE GOODS AND SERVICES OF OTHERS (U.S. CLS. 100, 101 AND 102).

TINA BROWN, EXAMINING ATTORNEY

SN 85-253,481. GESAWORLD, S.A., 08036 BARCELONA, SPAIN, FILED 2-28-2011.

GESAWORLD

THE MARK CONSISTS OF STANDARD CHARACTERS WITHOUT CLAIM TO ANY PARTICULAR FONT, STYLE, SIZE, OR COLOR.

FOR ADVERTISING; BUSINESS MANAGEMENT; BUSINESS ADMINISTRATION; OFFICE FUNCTIONS (U.S. CLS. 100, 101 AND 102).

KELLY BOULTON, EXAMINING ATTORNEY

CLASS 35—(Continued).

SN 85-253,632. TEXAS WRANGLERS, AUSTIN, TX. FILED 2-28-2011.



NO CLAIM IS MADE TO THE EXCLUSIVE RIGHT TO USE "TEXAS AND THE OUTLINE OF THE STATE OF TEXAS", APART FROM THE MARK AS SHOWN.

THE MARK CONSISTS OF THE IMAGE OF THE OUTLINE OF THE STATE OF TEXAS IN THE BACKGROUND WITH A LASSO WRAPPING AROUND THE STATE. THERE IS ALSO A STAR IN THE MIDDLE OF "TEXAS" AND "WRANGLERS" WHICH REPRESENTS THE LOCATION OF AUSTIN. IN THE MIDDLE OF THE LASSO AT A NEAR 45 DEGREE SLANT FROM LEFT TO RIGHT IS "TEXAS WRANGLERS" IN CURSIVE.

FOR ASSOCIATION SERVICES, NAMELY, ORGANIZING CHAPTERS OF A FRATERNITY AND PROMOTING THE INTERESTS OF THE MEMBERS THEREOF (U.S. CLS. 100, 101 AND 102).

FIRST USE 10-1-1979; IN COMMERCE 10-1-1979.
KAREN K. BUSH, EXAMINING ATTORNEY

SN 85-254,880. GLOBAL REACH OUT INITIATIVE, INC., ALEXANDRIA, VA. FILED 3-1-2011.

GLOBAL REACH OUT INITIATIVE

THE MARK CONSISTS OF STANDARD CHARACTERS WITHOUT CLAIM TO ANY PARTICULAR FONT, STYLE, SIZE, OR COLOR.

NO CLAIM IS MADE TO THE EXCLUSIVE RIGHT TO USE "INITIATIVE", APART FROM THE MARK AS SHOWN. FOR PUBLIC ADVOCACY TO PROMOTE AWARENESS OF DEAF RIGHTS (U.S. CLS. 100, 101 AND 102).

FIRST USE 3-14-2007; IN COMMERCE 3-14-2007.
CHRISTINA SOBRAL, EXAMINING ATTORNEY

CLASS 35—(Continued).

SN 85-254,894. GLOBAL REACH OUT INITIATIVE, INC., ALEXANDRIA, VA. FILED 3-1-2011.



NO CLAIM IS MADE TO THE EXCLUSIVE RIGHT TO USE "INITIATIVE", APART FROM THE MARK AS SHOWN. THE MARK CONSISTS OF THE LETTERS "GR" PRECEDING A GLOBE IMAGE ENCOMPASSED BY TWO FIGURES ALL OVER THE WORD "INITIATIVE". FOR PUBLIC ADVOCACY TO PROMOTE AWARENESS OF DEAF RIGHTS (U.S. CLS. 100, 101 AND 102). FIRST USE 2-16-2008; IN COMMERCE 2-16-2008. CHRISTINA SOBRAL, EXAMINING ATTORNEY

SN 85-254,912. U.S. FOODSERVICE, INC., ROSEMONT, IL. FILED 3-1-2011.

INSIGHT FOR THE
FOODSERVICE PROFESSIONAL

THE MARK CONSISTS OF STANDARD CHARACTERS WITHOUT CLAIM TO ANY PARTICULAR FONT, STYLE, SIZE, OR COLOR.

NO CLAIM IS MADE TO THE EXCLUSIVE RIGHT TO USE "FOODSERVICE PROFESSIONAL", APART FROM THE MARK AS SHOWN.

FOR PROMOTING THE SALE OF FOODS OF OTHERS BY DISTRIBUTION OF RECIPES FEATURING SELECTED FOOD ITEMS (U.S. CLS. 100, 101 AND 102). FIRST USE 4-0-2010; IN COMMERCE 4-0-2010. GINA HAYES, EXAMINING ATTORNEY

SN 85-255,066. CHARTREUSE & IVORY LLC, NORTH-RIDGE, CA. FILED 3-1-2011.

CHARTREUSE & IVORY

THE MARK CONSISTS OF STANDARD CHARACTERS WITHOUT CLAIM TO ANY PARTICULAR FONT, STYLE, SIZE, OR COLOR.

FOR ON-LINE RETAIL GIFT SHOPS; ON-LINE RETAIL STORE SERVICES FEATURING GIFT ITEMS AND ACCESSORIES, NAMELY, BLANK WRITING JOURNALS, BOOKMARKS, POSTCARDS, GREETING CARDS, NOTE CARDS, FABRIC TRAVEL BAGS, SHOE BAGS FOR TRAVEL, SHOE BAGS FOR STORAGE, LAUNDRY BAGS SACHETS, APRONS, NAPKINS, PLACE MATS (U.S. CLS. 100, 101 AND 102).

WILLIAM BRECKENFELD, EXAMINING ATTORNEY

CLASS 35—(Continued).

SN 85-255,327. HOSTETLER, DANIEL L, ARLINGTON HEIGHTS, IL. FILED 3-2-2011.



NO CLAIM IS MADE TO THE EXCLUSIVE RIGHT TO USE "ANALYTICS", APART FROM THE MARK AS SHOWN.

THE COLOR(S) BLUE AND GOLD IS/ARE CLAIMED AS A FEATURE OF THE MARK.

THE MARK CONSISTS OF "LA" SURROUNDED BY A SQUARE BORDER AND "LEGACY ANALYTICS" UNDERNEATH, ALL APPEARING IN GOLD ON A BLUE BACKGROUND.

FOR ACCOUNTING CONSULTATION; ASSISTANCE IN MANAGEMENT OF BUSINESS ACTIVITIES; ASSISTANCE WITH BUSINESS MANAGEMENT AND PLANNING; ASSISTANCE, ADVICE AND CONSULTANCY WITH REGARD TO BUSINESS PLANNING, BUSINESS ANALYSIS, BUSINESS MANAGEMENT AND BUSINESS ORGANIZATION RELATING TO PURCHASING FUNCTIONS; ASSISTANCE, ADVISORY SERVICES AND CONSULTANCY WITH REGARD TO BUSINESS PLANNING, BUSINESS ANALYSIS, BUSINESS MANAGEMENT, AND BUSINESS ORGANIZATION; ASSISTANCE, ADVISORY SERVICES AND CONSULTANCY WITH REGARD TO BUSINESS PLANNING, BUSINESS ANALYSIS, BUSINESS MANAGEMENT, AND BUSINESS ORGANIZATION RELATING TO MICRO CREDITS, MICRO FINANCE AND ENERGY PRODUCTS; ASSISTANCE, ADVISORY SERVICES AND CONSULTANCY WITH REGARD TO BUSINESS PLANNING, BUSINESS ANALYSIS, BUSINESS MANAGEMENT, BUSINESS ORGANIZATION, MARKETING AND CUSTOMER ANALYSIS; BUSINESS ADMINISTRATION AND MANAGEMENT; BUSINESS ADMINISTRATION AND OFFICE WORK; BUSINESS ADMINISTRATION ASSISTANCE; BUSINESS ADMINISTRATION CONSULTANCY; BUSINESS ADVICE AND ANALYSIS OF MARKETS; BUSINESS ADVICE AND INFORMATION; BUSINESS ADVICE, INQUIRIES OR INFORMATION; BUSINESS CONSULTATION; BUSINESS CONSULTATION IN THE FIELD OF BUSINESS LEADERSHIP DEVELOPMENT; BUSINESS CONSULTATION SERVICES; BUSINESS CONSULTATION SERVICES, NAMELY, BUSINESS PROCESS IMPROVEMENT AND ENTERPRISE ARCHITECTURE DESIGN; BUSINESS CONSULTING AND INFORMATION SERVICES; BUSINESS CONSULTING SERVICES IN THE FIELD OF BUSINESS KNOWLEDGE TRANSFER THROUGH AUDIO TOOLS, NAMELY, RECORDING INTERVIEWS WITH SUBJECT MATTER EXPERTS FOR AN ORGANIZATION'S CAPTURE AND FUTURE USE; BUSINESS CONSULTING SERVICES IN THE FIELD OF ORGANIZATIONAL CHANGE MANAGEMENT; BUSINESS CONSULTING SERVICES RELATING TO THE INTEGRATION OF THE AREAS OF BUSINESS PROCESS TECHNOLOGY, ORGANIZATIONAL LEARNING, CHANGE MANAGEMENT, AND OPERATIONAL SUSTAINABILITY; BUSINESS CONSULTING SERVICES, NAMELY, PROVIDING A TURNKEY SOLUTION FOR REVIEWING PRODUCT AND SERVICE DOCUMENTATION AND WORKFLOW, MANAGING PROJECTS FOR BUSINESS PURPOSES, TRACKING USER SATISFACTION, AND RUNNING USABILITY STUDIES FOR BUSINESS PURPOSES; BUSINESS CONSULTING SERVICES, NAMELY, PROVIDING ASSISTANCE IN DEVELOPMENT OF BUSINESS STRATEGIES AND CREATIVE

CLASS 35—(Continued).

IDEATION; BUSINESS CONSULTING, MANAGEMENT, PLANNING AND SUPERVISION; BUSINESS DATA ANALYSIS; BUSINESS DEVELOPMENT CONSULTING SERVICES; BUSINESS DEVELOPMENT SERVICES; BUSINESS DEVELOPMENT SERVICES, NAMELY, PROVIDING START-UP SUPPORT FOR BUSINESSES OF OTHERS; BUSINESS EFFICIENCY EXPERT SERVICES; BUSINESS FEASIBILITY STUDIES; BUSINESS INFORMATION MANAGEMENT; BUSINESS INFORMATION MANAGEMENT, NAMELY, ELECTRONIC REPORTING OF BUSINESS INFORMATION, BUSINESS ANALYTICS, NAMELY, BUSINESS INVESTIGATIONS, EVALUATIONS, EXPERT APPRAISALS, INFORMATION AND RESEARCH, TRADE SPEND BUSINESS MANAGEMENT; BUSINESS INFORMATION SERVICES IN THE NATURE OF PROVIDING INFORMATION ON BUSINESS OPPORTUNITIES; BUSINESS INVESTIGATIONS; BUSINESS INVESTIGATIONS, EVALUATIONS, EXPERT APPRAISALS, INFORMATION AND RESEARCH; BUSINESS KNOWLEDGE MANAGEMENT SERVICES; BUSINESS MANAGEMENT ADVICE; BUSINESS MANAGEMENT AND ADVICE; BUSINESS MANAGEMENT AND CONSULTATION; BUSINESS MANAGEMENT AND CONSULTATION IN THE FIELD OF CASE MANAGEMENT, INTEGRATED JUSTICE, DATA CONVERSIONS, AND BUSINESS INTELLIGENCE; BUSINESS MANAGEMENT AND ENTERPRISE ORGANIZATION CONSULTANCY; BUSINESS MANAGEMENT CONSULTANCY AND ADVISORY SERVICES; BUSINESS MANAGEMENT CONSULTANCY AS WELL AS DEVELOPMENT OF PROCESSES FOR THE ANALYSIS AND THE IMPLEMENTATION OF STRATEGY PLANS AND MANAGEMENT PROJECTS; BUSINESS MANAGEMENT CONSULTANCY IN THE FIELD OF PURCHASES, NAMELY, ASSISTING BUSINESSES IN IMPROVEMENT OF PURCHASING FUNCTIONS; BUSINESS MANAGEMENT CONSULTANCY SERVICES; BUSINESS MANAGEMENT CONSULTANCY, ALSO VIA THE INTERNET; BUSINESS MANAGEMENT CONSULTATION; BUSINESS MANAGEMENT CONSULTATION AND SERVICES, NAMELY, MANAGING AND ADMINISTERING NON-CORE FUNCTIONS, NAMELY, MAILING AND SHIPPING, RECORDS MANAGEMENT, INFORMATION SERVICES, ADMINISTRATION, PAYROLL AND ACCOUNTING, AND TELEMARKETING SERVICES; BUSINESS MANAGEMENT CONSULTATION IN THE FIELD OF EXECUTIVE AND LEADERSHIP DEVELOPMENT; BUSINESS MANAGEMENT CONSULTING; BUSINESS MANAGEMENT CONSULTING AND ADVISORY SERVICES; BUSINESS MANAGEMENT CONSULTING IN THE FIELD OF TEAM DEVELOPMENT; BUSINESS MANAGEMENT CONSULTING WITH RELATION TO STRATEGY, FINANCING, MARKETING, PRODUCTION, PERSONNEL AND SALE MATTERS FOR COMPANIES INVOLVED WITH THIN FILM AND NANO TECHNOLOGIES AND PLASMA PROCESSES; BUSINESS MANAGEMENT CONSULTING WITH RELATION TO STRATEGY, MARKETING, PRODUCTION, PERSONNEL AND RETAIL SALE MATTERS; BUSINESS MANAGEMENT CONSULTING WITH RELATION TO STRATEGY, MARKETING, SALES, OPERATION, PRODUCT DESIGN PARTICULARLY SPECIALIZING IN THE USE OF ANALYTIC AND STATISTIC MODELS FOR THE UNDERSTANDING AND PREDICTING OF CONSUMERS, BUSINESSES, AND MARKET TRENDS AND ACTIONS; BUSINESS MANAGEMENT FOR A TRADE COMPANY AND FOR A SERVICE COMPANY; BUSINESS MANAGEMENT FOR SHOPS; BUSINESS MANAGEMENT FOR THE MOBILE VETERINARY PRACTICE OF OTHERS; BUSINESS MANAGEMENT IN THE FIELD OF TRANSPORT AND DELIVERY; BUSINESS MANAGEMENT SERVICES, NAMELY, MANAGING LOGISTICS, REVERSE LOGISTICS, SUPPLY CHAIN SERVICES, SUPPLY CHAIN VISIBILITY AND SYNCHRONIZATION, SUPPLY AND DEMAND FORECASTING AND PRODUCT DISTRIBUTION PROCESSES FOR OTHERS; BUSINESS MANAGEMENT SERVICES, NAMELY, PURCHASING OF AND SELLING OF COMPANIES FOR OTHERS; BUSINESS MANAGEMENT SUPERVISION; BUSINESS MARKETING CONSULTING SERVICES TO CHILD-CARE ORGANIZATIONS; BUSINESS MARKETING SERVICES; BUSINESS MERGER CONSULTATION; BUSINESS OPERATION, BUSINESS ADMINISTRATION AND OFFICE FUNCTIONS; BUSINESS ORGANIZATION CONSULTING; BUSINESS ORGANIZATION ADVICE; BUSINESS ORGANIZATION AND MANAGEMENT

CLASS 35—(Continued).

CONSULTANCY INCLUDING PERSONNEL MANAGEMENT; BUSINESS ORGANIZATION AND MANAGEMENT CONSULTING; BUSINESS ORGANIZATION AND OPERATION CONSULTANCY; BUSINESS ORGANIZATION CONSULTING; BUSINESS ORGANIZATIONAL CONSULTATION; BUSINESS PLANNING; BUSINESS PROCESS RE-ENGINEERING SERVICES; BUSINESS RECORDS MANAGEMENT; BUSINESS RELOCATION CONSULTING; BUSINESS RESEARCH; BUSINESS RESEARCH AND SURVEYS; BUSINESS RESEARCH CONSULTATION; BUSINESS RISK ASSESSMENT SERVICES; BUSINESS RISK MANAGEMENT; BUSINESS RISK MANAGEMENT CONSULTATION; BUSINESS SERVICES, NAMELY, FACILITIES MANAGEMENT OF TECHNICAL OPERATIONS (U.S. CLS. 100, 101 AND 102).

FIRST USE 8-1-2010; IN COMMERCE 8-1-2010.
ANDREA BUTLER, EXAMINING ATTORNEY

SN 85-256,151. ARIZONA CHARTER SCHOOLS ASSOCIATION, PHOENIX, AZ. FILED 3-2-2011.

Arizona Charter Schools Association

THE MARK CONSISTS OF STANDARD CHARACTERS WITHOUT CLAIM TO ANY PARTICULAR FONT, STYLE, SIZE, OR COLOR.

NO CLAIM IS MADE TO THE EXCLUSIVE RIGHT TO USE "ASSOCIATION", APART FROM THE MARK AS SHOWN.

SEC. 2(F).

FOR ASSOCIATION SERVICES, NAMELY, PROMOTING THE INTERESTS OF CHARTER SCHOOLS (U.S. CLS. 100, 101 AND 102).

FIRST USE 12-28-1995; IN COMMERCE 12-28-1995.
MIDGE BUTLER, EXAMINING ATTORNEY

SN 85-257,745. WILLIAM NEAL SCARBOROUGH, SAN ANTONIO, TX. FILED 3-4-2011.

DIALED IN SPORTS

THE MARK CONSISTS OF STANDARD CHARACTERS WITHOUT CLAIM TO ANY PARTICULAR FONT, STYLE, SIZE, OR COLOR.

NO CLAIM IS MADE TO THE EXCLUSIVE RIGHT TO USE "SPORTS", APART FROM THE MARK AS SHOWN.

FOR RETAIL SPORTING GOODS STORES (U.S. CLS. 100, 101 AND 102).

FIRST USE 2-1-2011; IN COMMERCE 2-1-2011.

MARGERY A. TIERNEY, EXAMINING ATTORNEY

CLASS 35—(Continued).

SN 85-258,076. NBCUNIVERSAL MEDIA, LLC, NEW YORK, NY. FILED 3-4-2011.

BE INFORMED. BE
ENTERTAINED. BE INSPIRED.

THE MARK CONSISTS OF STANDARD CHARACTERS WITHOUT CLAIM TO ANY PARTICULAR FONT, STYLE, SIZE, OR COLOR.

FOR PROMOTING AWARENESS OF HEALTH-RELATED ISSUES (U.S. CLS. 100, 101 AND 102).

FIRST USE 6-14-2010; IN COMMERCE 6-14-2010.
HAI-LY LAM, EXAMINING ATTORNEY

SN 85-258,234. AUTOBEGREEN, LLC, EXETER, NH. FILED 3-4-2011.

AUTOBEGREEN

THE MARK CONSISTS OF STANDARD CHARACTERS WITHOUT CLAIM TO ANY PARTICULAR FONT, STYLE, SIZE, OR COLOR.

FOR RETAIL STORE AND ON-LINE RETAIL STORE SERVICES FEATURING ENVIRONMENTALLY FRIENDLY AUTO REPLACEMENT PARTS AND RELATED SERVICES (U.S. CLS. 100, 101 AND 102).

FIRST USE 12-29-2010; IN COMMERCE 12-29-2010.
LINDA E. BLOHM, EXAMINING ATTORNEY

SN 85-258,526. H.D. SMITH WHOLESALE DRUG CO., SPRINGFIELD, IL. FILED 3-4-2011.

PharmaRxEACH

THE MARK CONSISTS OF STANDARD CHARACTERS WITHOUT CLAIM TO ANY PARTICULAR FONT, STYLE, SIZE, OR COLOR.

FOR WHOLESALE DISTRIBUTORSHIPS FEATURING PHARMACEUTICALS AND GENERIC DRUGS (U.S. CLS. 100, 101 AND 102).

PAUL MORENO, EXAMINING ATTORNEY

CLASS 35—(Continued).

SN 85-259,078. MUSELLO, DAMIAN R., SOMERVILLE, MA. FILED 3-5-2011.

The Party Of the People,
By the People, For the
People

THE MARK CONSISTS OF STANDARD CHARACTERS WITHOUT CLAIM TO ANY PARTICULAR FONT, STYLE, SIZE, OR COLOR.

FOR ADVERTISING AND PUBLICITY SERVICES, NAMELY, PROMOTING THE GOODS, SERVICES, BRAND IDENTITY AND COMMERCIAL INFORMATION AND NEWS OF THIRD PARTIES THROUGH PRINT, AUDIO, VIDEO, DIGITAL AND ON-LINE MEDIUM; ADVERTISING IN PERIODICALS, BROCHURES AND NEWSPAPERS; ADVERTISING IN THE POPULAR AND PROFESSIONAL PRESS; ADVERTISING ON THE INTERNET FOR OTHERS; ADVERTISING PARTICULARLY SERVICES FOR THE PROMOTION OF GOODS; ADVERTISING SERVICES, NAMELY, CREATING CORPORATE AND BRAND IDENTITY FOR OTHERS; ADVERTISING SERVICES, NAMELY, PROMOTING AND MARKETING THE GOODS AND SERVICES OF OTHERS THROUGH ALL PUBLIC COMMUNICATION MEANS; ADVERTISING SERVICES, NAMELY, PROMOTING THE BRANDS, GOODS AND SERVICES OF OTHERS; ADVERTISING SERVICES, NAMELY, CREATING CORPORATE AND BRAND IDENTITY FOR CANDIDATES FOR PUBLIC OFFICE, FOR CORPORATIONS WORKING IN SUPPORT OF CANDIDATES FOR PUBLIC OFFICE AND FOR ORGANIZATIONS WORKING IN SUPPORT FOR CANDIDATES FOR PUBLIC OFFICE (U.S. CLS. 100, 101 AND 102).

KIMBERLY PERRY, EXAMINING ATTORNEY

SN 85-259,893. THE CANDY CRATE, LLP, RED RIVER, NM. FILED 3-7-2011.

CANDY MOUNTAIN FUDGE

THE MARK CONSISTS OF STANDARD CHARACTERS WITHOUT CLAIM TO ANY PARTICULAR FONT, STYLE, SIZE, OR COLOR.

NO CLAIM IS MADE TO THE EXCLUSIVE RIGHT TO USE "CANDY" AND "FUDGE", APART FROM THE MARK AS SHOWN.

FOR WHOLESALE, RETAIL, AND ON-LINE STORE SERVICES FEATURING CONFECTIONARIES, POP-CORN, CHOCOLATE, GOURMET ITEMS, AND SOUVENIRS (U.S. CLS. 100, 101 AND 102).

FIRST USE 12-1-2010; IN COMMERCE 12-1-2010.
LAURIE MAYES, EXAMINING ATTORNEY

CLASS 35—(Continued).

SN 85-260,240. SMALL BUSINESS FINANCIAL MANAGEMENT GROUP, INC., DBA MY GOOD ACCOUNTANT, ROWLETT, TX. FILED 3-7-2011.

The Business Growing Accountant

THE MARK CONSISTS OF STANDARD CHARACTERS WITHOUT CLAIM TO ANY PARTICULAR FONT, STYLE, SIZE, OR COLOR.

NO CLAIM IS MADE TO THE EXCLUSIVE RIGHT TO USE "ACCOUNTANT", APART FROM THE MARK AS SHOWN.

FOR ACCOUNTANCY SERVICES; ACCOUNTING CONSULTATION; ACCOUNTING FOR THIRD PARTIES; ACCOUNTING SERVICES; ACCOUNTS RECEIVABLE SERVICES; ADMINISTRATION OF BUSINESS PAYROLL FOR OTHERS; ADMINISTRATION, BILLING AND RECONCILIATION OF ACCOUNTS ON BEHALF OF OTHERS; ADMINISTRATIVE ACCOUNTING; BUSINESS ADVISORY SERVICES, CONSULTANCY AND INFORMATION; BUSINESS CONSULTATION SERVICES; BUSINESS INFORMATION AND ACCOUNTING ADVISORY SERVICES; BUSINESS MANAGEMENT AND CONSULTING SERVICES FOR THE HEALTH CARE INDUSTRY, NAMELY, CUSTOMER SERVICE, ACCOUNTING SERVICES, AND MARKETING SERVICES; BUSINESS MANAGEMENT AND CONSULTING SERVICES FOR THE HEALTH CARE INDUSTRY, NAMELY, CUSTOMER SERVICE, ACCOUNTING SERVICES, AND WEB-BASED ADVERTISING AND MARKETING SERVICES; BUSINESS MANAGEMENT CONSULTATION AND SERVICES, NAMELY, MANAGING AND ADMINISTERING NON-CORE FUNCTIONS, NAMELY, MAILING AND SHIPPING, RECORDS MANAGEMENT, INFORMATION SERVICES, ADMINISTRATION, PAYROLL AND ACCOUNTING, AND TELEMARKETING SERVICES; COMPUTERIZED ACCOUNTING SERVICES; CONSULTING AND INFORMATION CONCERNING ACCOUNTING; CONSULTING SERVICES, NAMELY, EXPERT ANALYSIS AND MANAGEMENT CONSULTING IN ECONOMICS AND ACCOUNTING; COST ACCOUNTING; DATA MANAGEMENT SERVICE FOR USE IN REPORTING DEBT COLLECTION ACCOUNTS TO A COLLECTION AGENCY; FORENSIC ACCOUNTING SERVICES; INCOME TAX CONSULTATION; INCOME TAX PREPARATION; PROVIDING ONLINE BUSINESS MANAGEMENT SERVICES INCLUDING ACCOUNTING, MARKETING, BUSINESS PROJECT MANAGEMENT, AND BUSINESS DEVELOPMENT; TAX ADVISORY SERVICES; TAX AND TAXATION PLANNING, ADVICE, INFORMATION AND CONSULTANCY SERVICES; TAX CONSULTATION; TAX FILING SERVICES; TAX PREPARATION (U.S. CLS. 100, 101 AND 102).

ASMAT KHAN, EXAMINING ATTORNEY

CLASS 35—(Continued).

SN 85-261,413. O.N.E. INC. FASHION, DBA O.N.E. INC. FASHION [OFFICIAL NUMBER-1 ENTERTAINMENT], FOREST PARK, GA. FILED 3-8-2011.



NO CLAIM IS MADE TO THE EXCLUSIVE RIGHT TO USE "INC." "FASHION" AND "ENTERTAINMENT", APART FROM THE MARK AS SHOWN.

THE COLOR(S) BLUE, WHITE AND GRAY IS/ARE CLAIMED AS A FEATURE OF THE MARK.

THE MARK CONSISTS OF THE WORDING "O.N.E. INC. FASHION OFFICIAL NUMBER-1 ENTERTAINMENT" IN STYLIZED BLUE LETTERS, AND A DESIGN COMPRISING A THREE-DIMENSIONAL SPHERE IN BLUE OUTLINED IN WHITE AND GRAY WITH A WHITE DIAMOND, WHITE STAR AND DESIGN OF A GRAY AND WHITE LION ON A BLUE PLATFORM INSIDE THE SPHERE, THREE SMALLER BLUE BUBBLES AND A MID-SIZE BUBBLE IN BLUE WITH TWO STARS IN WHITE.

FOR BUSINESS MANAGEMENT CONSULTING SERVICES IN THE FIELD OF INTERNET MARKETING ADVERTISING; ADVERTISING AND ADVERTISEMENT SERVICES; PLACING OF ADVERTISEMENTS FOR OTHERS; PREPARING ADVERTISEMENTS FOR OTHERS; MARKETING SERVICES, NAMELY, PROMOTING THE GOODS AND SERVICES OF OTHERS; AND PROVIDING AN ON-LINE SEARCHABLE DATABASE FEATURING BUSINESS INFORMATION AND BUSINESS CONTACTS (U.S. CLS. 100, 101 AND 102).

PATRICIA EVANKO, EXAMINING ATTORNEY

SN 85-261,559. NATURAL SELECTION FOODS, LLC, SAN JUAN BAUTISTA, CA. FILED 3-8-2011.

EVERY BODY DESERVES ORGANIC

THE MARK CONSISTS OF STANDARD CHARACTERS WITHOUT CLAIM TO ANY PARTICULAR FONT, STYLE, SIZE, OR COLOR.

FOR PROMOTING PUBLIC AWARENESS IN THE FIELD OF NUTRITION AND HEALTH; PROMOTING PUBLIC AWARENESS IN THE FIELD OF FOOD PRODUCTION AND SAFETY (U.S. CLS. 100, 101 AND 102).

JACLYN KIDWELL WALKER, EXAMINING ATTORNEY

CLASS 35—(Continued).

SN 85-262,398. THE GROW ROOM, L.L.C., PHOENIX, AZ.
FILED 3-9-2011.

GROLOTS

THE MARK CONSISTS OF STANDARD CHARACTERS WITHOUT CLAIM TO ANY PARTICULAR FONT, STYLE, SIZE, OR COLOR.

FOR RETAIL STORE AND ON-LINE RETAIL STORE SERVICES FEATURING GARDEN SUPPLIES; RETAIL STORE SERVICES FEATURING GARDEN SUPPLIES; WHOLESALE AND RETAIL STORE SERVICES FEATURING GARDEN SUPPLIES (U.S. CLS. 100, 101 AND 102).
LINDA ORNDORFF, EXAMINING ATTORNEY

SN 85-262,760. TECHSTARS CENTRAL LLC, BOULDER, CO.
FILED 3-9-2011.

TECHSTARS NETWORK

THE MARK CONSISTS OF STANDARD CHARACTERS WITHOUT CLAIM TO ANY PARTICULAR FONT, STYLE, SIZE, OR COLOR.

OWNER OF U.S. REG. NO. 3,741,647.
NO CLAIM IS MADE TO THE EXCLUSIVE RIGHT TO USE "NETWORK", APART FROM THE MARK AS SHOWN.
FOR BUSINESS ADVISORY SERVICES, CONSULTANCY AND INFORMATION; ASSOCIATION SERVICES, NAMELY, PROMOTING THE INTERESTS OF PARTIES OR ORGANIZATIONS OFFERING START-UP ACCELERATOR PROGRAMS (U.S. CLS. 100, 101 AND 102).

FIRST USE 1-31-2011; IN COMMERCE 1-31-2011.
CHRISTINE COOPER, EXAMINING ATTORNEY

CLASS 35—(Continued).

SN 85-264,401. COLORECTAL CANCER COALITION, INC.,
ALEXANDRIA, VA. FILED 3-11-2011.



OWNER OF U.S. REG. NOS. 3,176,724 AND 3,956,211.
NO CLAIM IS MADE TO THE EXCLUSIVE RIGHT TO USE "FIGHT COLORECTAL CANCER", APART FROM THE MARK AS SHOWN.

THE MARK CONSISTS OF A STYLIZED BOX LOGO WITH THE WORDS "FIGHT COLORECTAL CANCER".

FOR PROMOTING PUBLIC AWARENESS OF PATIENT ISSUES RELATING TO COLORECTAL CANCER PREVENTION AND TREATMENT TO THE PUBLIC AND RESEARCHERS, PHYSICIANS AND POLICY MAKERS IN THE MEDICAL FIELD (U.S. CLS. 100, 101 AND 102).

FIRST USE 3-7-2011; IN COMMERCE 3-7-2011.
INGRID C. EULIN, EXAMINING ATTORNEY

SN 85-264,449. SWINGBLING, LLC, MOUNT PLEASANT, SC.
FILED 3-11-2011.

SWINGBLING

NO CLAIM IS MADE TO THE EXCLUSIVE RIGHT TO USE "BLING", APART FROM THE MARK AS SHOWN.

THE MARK CONSISTS OF THE WORD "SWINGBLING" WITH A CAPITAL "S" AND A CAPITAL "B". THE LETTERS "SWING" SHOWS GLASS LIKE LETTERS WITH THE LETTERS "BLING" HAVING DIAMOND LIKE LETTERS.

FOR COMPUTERIZED ON-LINE RETAIL STORE SERVICES IN THE FIELD OF JEWELRY; ON-LINE RETAIL STORE SERVICES FEATURING A WIDE VARIETY OF CONSUMER GOODS OF OTHERS; ON-LINE RETAIL STORE SERVICES FEATURING JEWELRY (U.S. CLS. 100, 101 AND 102).

FIRST USE 3-4-2011; IN COMMERCE 3-4-2011.
CHARLOTTE CORWIN, EXAMINING ATTORNEY

CLASS 35—(Continued).

SN 85-265,200. THORDSEN CUSTOMS, SOUTH SAN FRANCISCO, CA. FILED 3-11-2011.



NO CLAIM IS MADE TO THE EXCLUSIVE RIGHT TO USE "CUSTOMS", APART FROM THE MARK AS SHOWN. THE MARK CONSISTS OF THE STYLIZED WORDS AND LETTERS "THORDSEN . CUSTOMS . TC" WITHIN A CIRCULAR SHAPED DESIGN.

FOR WHOLESALE AND RETAIL STORE SERVICES FEATURING MAGAZINES AND MAGAZINE ACCESSORIES FOR RIFLES, HAND GRIPS AND ACCESSORIES FOR SMALL FIREARMS, HAND GRIPS AND ACCESSORIES FOR RIFLES, MAGAZINE RELEASE TOOLS AND ACCESSORIES FOR SMALL FIREARMS AND RIFLES (U.S. CLS. 100, 101 AND 102).

FIRST USE 1-1-2007; IN COMMERCE 1-1-2011.
WILLIAM ROSSMAN, EXAMINING ATTORNEY

SN 85-265,786. DICKENS BOOKS, LTD., MILWAUKEE, WI. FILED 3-14-2011.

800CEORead

THE MARK CONSISTS OF STANDARD CHARACTERS WITHOUT CLAIM TO ANY PARTICULAR FONT, STYLE, SIZE, OR COLOR.

OWNER OF U.S. REG. NO. 2,498,897.
FOR RETAIL STORE SERVICES FEATURING BOOKS ACCESSIBLE ON-LINE AND BY TELEPHONE, FACSIMILE AND MAIL ORDER (U.S. CLS. 100, 101 AND 102).
FIRST USE 10-0-1998; IN COMMERCE 10-0-1998.
NICHOLAS COLEMAN, EXAMINING ATTORNEY

CLASS 35—(Continued).

SN 85-266,135. SOCIAL SECURITY SOLUTIONS, INC., LEAWOOD, KS. FILED 3-14-2011.

NO CLAIM IS MADE TO THE EXCLUSIVE RIGHT TO USE "SOCIAL SECURITY", APART FROM THE MARK AS SHOWN.

THE MARK CONSISTS OF A SQUARE WITH ROUNDED CORNERS. INSIDE THE SQUARE, A CURVED LINE EXTENDS FROM THE LOWER LEFT CORNER TO THE RIGHT SIDE OF THE SQUARE. A CURVED LINE WITH AN ARROW AT THE TIP EXTENDS INSIDE THE SQUARE FROM THE BOTTOM OF THE SQUARE OUT THE TOP OF THE UPPER RIGHT CORNER. TO THE RIGHT OF THE SQUARE ARE THE WORDS "SOCIAL SECURITY SOLUTIONS".

FOR BUSINESS CONSULTING SERVICES IN THE FIELD OF SOCIAL SECURITY BENEFITS (U.S. CLS. 100, 101 AND 102).

FIRST USE 12-15-2010; IN COMMERCE 12-15-2010.
PAULA MAHONEY, EXAMINING ATTORNEY

SN 85-267,234. BV RETAIL, LLC, CHARLOTTE, NC. FILED 3-15-2011.

THE CROWN OF THE QUEEN CITY

THE MARK CONSISTS OF STANDARD CHARACTERS WITHOUT CLAIM TO ANY PARTICULAR FONT, STYLE, SIZE, OR COLOR.

NO CLAIM IS MADE TO THE EXCLUSIVE RIGHT TO USE "QUEEN CITY", APART FROM THE MARK AS SHOWN.

FOR ADVERTISING, PROMOTION, AND MARKETING SERVICES IN THE NATURE OF PRINT, WEB, RADIO, TV ADVERTISING FOR RETAIL SHOPPING CENTER TENANTS (U.S. CLS. 100, 101 AND 102).

FIRST USE 4-0-2009; IN COMMERCE 4-0-2009.
CIMMERIAN COLEMAN, EXAMINING ATTORNEY

CLASS 35—(Continued).

SN 85-269,385. AMERICAN COLLEGE OF SPORTS MEDICINE, INC., INDIANAPOLIS, IN. FILED 3-17-2011.

LET'S MOVE HEALTHCARE

THE MARK CONSISTS OF STANDARD CHARACTERS WITHOUT CLAIM TO ANY PARTICULAR FONT, STYLE, SIZE, OR COLOR.

NO CLAIM IS MADE TO THE EXCLUSIVE RIGHT TO USE "HEALTHCARE", APART FROM THE MARK AS SHOWN.

FOR PROMOTING PUBLIC AWARENESS OF THE IMPORTANCE OF THE RELATIONSHIP BETWEEN PATIENTS AND HEALTHCARE PROVIDERS, AND STRATEGIES TO INCREASE THE FREQUENCY AND EFFECTIVENESS OF INTERACTIONS BETWEEN PATIENTS AND HEALTHCARE PROVIDERS (U.S. CLS. 100, 101 AND 102).

FLORENTINA BLANDU, EXAMINING ATTORNEY

SN 85-270,153. ATTISHA, MARCO, SAN JOSE, CA. FILED 3-17-2011.

YABOYAH

THE MARK CONSISTS OF STANDARD CHARACTERS WITHOUT CLAIM TO ANY PARTICULAR FONT, STYLE, SIZE, OR COLOR.

FOR PROVIDING A WEB SITE AT WHICH USERS CAN OFFER GOODS FOR SALE AND BUY GOODS OFFERED BY OTHERS; PROVIDING A WEB SITE THAT FEATURES AN ON-LINE MARKET FOR USERS TO LIST OFFERED OR WANTED PERSONAL AND BUSINESS ASSETS AND SKILLS FOR HIRE, RENT, SALE OR AUCTION TRANSACTED ON THE BASIS OF PREDEFINED PERFORMANCE AND CLOSING TERMS AND CONDITIONS; PROVIDING A WEBSITE FEATURING AN ONLINE MARKETPLACE FOR EXCHANGING GOODS AND SERVICES WITH OTHER USERS; PROVIDING A WEBSITE FOR CONNECTING SELLERS WITH BUYERS (U.S. CLS. 100, 101 AND 102).

MARGARET POWER, EXAMINING ATTORNEY

CLASS 35—(Continued).

SN 85-270,175. GENERATION PHILANTHROPY, NORTH HOLLYWOOD, CA. FILED 3-17-2011.

Generation Philanthropy

THE MARK CONSISTS OF STANDARD CHARACTERS WITHOUT CLAIM TO ANY PARTICULAR FONT, STYLE, SIZE, OR COLOR.

NO CLAIM IS MADE TO THE EXCLUSIVE RIGHT TO USE "PHILANTHROPY", APART FROM THE MARK AS SHOWN.

FOR CHARITABLE SERVICES, NAMELY, ORGANIZING YOUTH TO RAISE FUNDS FOR AND AWARENESS OF CHARITABLE NON-PROFIT ORGANIZATIONS THAT SERVE THE COMMUNITY AND NEED SUPPORT (U.S. CLS. 100, 101 AND 102).

FIRST USE 5-13-2010; IN COMMERCE 8-22-2010.

CHRISIE B. KING, EXAMINING ATTORNEY

SN 85-270,213. MY FOOT IN THE DOOR, HAMBURG, PA. FILED 3-17-2011.

My Foot In The Door

THE MARK CONSISTS OF STANDARD CHARACTERS WITHOUT CLAIM TO ANY PARTICULAR FONT, STYLE, SIZE, OR COLOR.

FOR PROVIDING ON-LINE PERSONNEL RECRUITMENT, PERSONNEL MANAGEMENT INFORMATION AND JOB SEARCHING INFORMATION SERVICES; PROVIDING AN INTERACTIVE COMPUTER DATABASE FEATURING RECRUITMENT AND EMPLOYMENT INFORMATION, EMPLOYMENT ADVERTISING, CAREER INFORMATION AND RESOURCES, RESUME CREATION AND POSTING; PROVIDING A DATABASE OF RESUMES OF PROSPECTIVE EMPLOYEES (U.S. CLS. 100, 101 AND 102).

WILLIAM BRECKENFELD, EXAMINING ATTORNEY

SN 85-270,252. FAIRWAY GROUP ACQUISITION COMPANY, NEW YORK, NY. FILED 3-17-2011.

LIKE NO OTHER WINES & SPIRITS STORE

THE MARK CONSISTS OF STANDARD CHARACTERS WITHOUT CLAIM TO ANY PARTICULAR FONT, STYLE, SIZE, OR COLOR.

OWNER OF U.S. REG. NOS. 3,545,835, 3,928,817 AND OTHERS.

FOR RETAIL AND ONLINE RETAIL STORE SERVICES FEATURING WINES AND SPIRITS (U.S. CLS. 100, 101 AND 102).

FIRST USE 12-15-2010; IN COMMERCE 12-15-2010.

CARYN GLASSER, EXAMINING ATTORNEY

CLASS 35—(Continued).

SN 85-270,589. G.N. RESEARCH S.A., LUXEMBOURG, LUXEMBOURG, FILED 3-18-2011.

SEEDING LAB

THE MARK CONSISTS OF STANDARD CHARACTERS WITHOUT CLAIM TO ANY PARTICULAR FONT, STYLE, SIZE, OR COLOR.

NO CLAIM IS MADE TO THE EXCLUSIVE RIGHT TO USE "LAB", APART FROM THE MARK AS SHOWN.

FOR MARKET RESEARCH AND QUALITATIVE MARKET RESEARCH ANALYSIS SERVICES (U.S. CLS. 100, 101 AND 102).

JACLYN KIDWELL WALKER, EXAMINING ATTORNEY

SN 85-270,885. SWAMI BAPA INC., DBA MP MANAGEMENT COMPANY, RICHBURG, SC. FILED 3-18-2011.



NO CLAIM IS MADE TO THE EXCLUSIVE RIGHT TO USE "MANAGEMENT COMPANY", APART FROM THE MARK AS SHOWN.

THE COLOR(S) ORANGE, MAROON, GREEN, YELLOW, BLUE, BLACK, WHITE IS/ARE CLAIMED AS A FEATURE OF THE MARK.

THE MARK CONSISTS OF THE COLORS ORANGE, MAROON, GREEN, YELLOW, BLUE WHICH APPEAR ON THE FIVE BLOCKS OF THE MARK. THE COLORS APPEAR IN THE ORDER FROM ORANGE, WHICH WILL BE AT THE BOTTOM TO BLUE WHICH WILL BE THE TOP MOST BLOCK. AFTER, ORANGE WILL BE MAROON, THEN GREEN, YELLOW, AND THE LAST BLOCK WHICH WILL BE BLUE. FURTHERMORE, THE LETTERS, "MP" APPEAR IN WHITE AND THEY ARE OUTLINED WITH THE COLOR BLACK. THE WORDS "MANAGEMENT COMPANY" APPEAR UNDERNEATH THE LETTERS "MP" AND THEY ARE IN BLACK COLOR.

FOR MANAGING C-STORES FOR OTHERS (U.S. CLS. 100, 101 AND 102).

FLORENTINA BLANDU, EXAMINING ATTORNEY

CLASS 35—(Continued).

SN 85-271,147. CAMBRIA CONSULTING, INC., BOSTON, MA. FILED 3-18-2011.

COACHING DIRECTOR

THE MARK CONSISTS OF STANDARD CHARACTERS WITHOUT CLAIM TO ANY PARTICULAR FONT, STYLE, SIZE, OR COLOR.

NO CLAIM IS MADE TO THE EXCLUSIVE RIGHT TO USE "COACHING", APART FROM THE MARK AS SHOWN.

FOR PROVIDING A WEB-BASED ONLINE PORTAL IN THE FIELD OF BUSINESS MANAGEMENT AND HUMAN RESOURCES FOR BUSINESS COACHES AND BUSINESS COACHING MANAGERS TO ENTER, TRACK AND MANAGE BUSINESS COACHING ACTIVITIES AND TO ACCESS, ORGANIZE, SYNTHESIZE AND REPORT INFORMATION FOR ALL BUSINESS COACHING ENGAGEMENTS (U.S. CLS. 100, 101 AND 102).

FIRST USE 11-3-2005; IN COMMERCE 11-3-2005.

DAWN HAN, EXAMINING ATTORNEY

SN 85-271,539. LM ORGANIZING SOLUTIONS, LLC, WARWICK, NY. FILED 3-19-2011.

LM Organizing Solutions

THE MARK CONSISTS OF STANDARD CHARACTERS WITHOUT CLAIM TO ANY PARTICULAR FONT, STYLE, SIZE, OR COLOR.

NO CLAIM IS MADE TO THE EXCLUSIVE RIGHT TO USE "ORGANIZING SOLUTIONS", APART FROM THE MARK AS SHOWN.

FOR PROVIDING ORGANIZING SERVICES FOR INDIVIDUALS AT HOME, IN HOME OFFICES AND IN BUSINESS OFFICES, THAT PROVIDES HELP WITH TIME AND PAPER MANAGEMENT (U.S. CLS. 100, 101 AND 102).

FIRST USE 1-27-2002; IN COMMERCE 9-27-2002.

KIMBERLY FRYE, EXAMINING ATTORNEY

SN 85-272,502. WOODRUFF-SAWYER & CO., SAN FRANCISCO, CA. FILED 3-21-2011.

BENEFITRESPONSE

THE MARK CONSISTS OF STANDARD CHARACTERS WITHOUT CLAIM TO ANY PARTICULAR FONT, STYLE, SIZE, OR COLOR.

FOR CUSTOMER SUPPORT SERVICES FOR EMPLOYEE BENEFITS CONCERNING INSURANCE AND FINANCE, NAMELY, HELP DESK SERVICES IN THE NATURE OF RESPONDING TO CUSTOMER INQUIRIES (U.S. CLS. 100, 101 AND 102).

FIRST USE 5-18-2010; IN COMMERCE 5-18-2010.

KARANENDRA S. CHHINA, EXAMINING ATTORNEY

CLASS 35—(Continued).

SN 85-272,516. IN ADD MINUS LLC, LOS ANGELES, CA. FILED 3-21-2011.



THE MARK CONSISTS OF THE INITIALS "IAM" IN STYLIZED FONT ABOVE THE WORDS "IN ADD MINUS" IN STYLIZED FONT.

FOR RETAIL STORE SERVICES FEATURING CLOTHING, JEWELRY AND FASHION ACCESSORIES (U.S. CLS. 100, 101 AND 102).

MATTHEW MCDOWELL, EXAMINING ATTORNEY

SN 85-272,536. IN ADD MINUS LLC, LOS ANGELES, CA. FILED 3-21-2011.

IN ADD MINUS

THE MARK CONSISTS OF STANDARD CHARACTERS WITHOUT CLAIM TO ANY PARTICULAR FONT, STYLE, SIZE, OR COLOR.

FOR RETAIL STORE SERVICES FEATURING CLOTHING, JEWELRY AND FASHION ACCESSORIES (U.S. CLS. 100, 101 AND 102).

MATTHEW MCDOWELL, EXAMINING ATTORNEY

SN 85-272,970. UNITED SPECIALTY ADVERTISING LLC, FORT WORTH, TX. FILED 3-22-2011.

**UNITED SPECIALTY
ADVERTISING**

THE MARK CONSISTS OF STANDARD CHARACTERS WITHOUT CLAIM TO ANY PARTICULAR FONT, STYLE, SIZE, OR COLOR.

NO CLAIM IS MADE TO THE EXCLUSIVE RIGHT TO USE "SPECIALTY ADVERTISING", APART FROM THE MARK AS SHOWN.

FOR SPECIALTY MERCHANDISING SERVICES, NAMELY, PROMOTING THE GOODS AND SERVICES OF OTHERS THROUGH THE DISTRIBUTION OF CUSTOMIZED ADVERTISING MATERIALS, NAMELY, T-SHIRTS, HATS, JERSEYS, SWEATSHIRTS, AND LONG SLEEVE SHIRTS (U.S. CLS. 100, 101 AND 102).

FIRST USE 4-3-2003; IN COMMERCE 4-3-2003.

KATHERINE E. HALMEN, EXAMINING ATTORNEY

CLASS 35—(Continued).

SN 85-273,647. TIGERRISK PARTNERS LLC, STAMFORD, CT. FILED 3-22-2011.

TigerEye

THE MARK CONSISTS OF STANDARD CHARACTERS WITHOUT CLAIM TO ANY PARTICULAR FONT, STYLE, SIZE, OR COLOR.

FOR REINSURANCE PRICING ANALYSIS SERVICES (U.S. CLS. 100, 101 AND 102).

DAVID H. STINE, EXAMINING ATTORNEY

SN 85-273,665. TERREBONNE PARISH CONSOLIDATED GOVERNMENT, HOUMA, LA. FILED 3-22-2011.

**Saltwater Fishing Capital
of the World**

THE MARK CONSISTS OF STANDARD CHARACTERS WITHOUT CLAIM TO ANY PARTICULAR FONT, STYLE, SIZE, OR COLOR.

NO CLAIM IS MADE TO THE EXCLUSIVE RIGHT TO USE "SALTWATER FISHING", APART FROM THE MARK AS SHOWN.

FOR PROMOTING THE ECONOMIC DEVELOPMENT IN THE PARISH OF TERREBONNE, STATE OF LOUISIANA; PROMOTING TOURISM IN TERREBONNE PARISH, LOUISIANA AREA (U.S. CLS. 100, 101 AND 102).

SIMON TENG, EXAMINING ATTORNEY

SN 85-273,751. FASHION & BEAUTY WEEK, A NON-PROFIT CORPORATION, NORTH CALDWELL, NJ. FILED 3-22-2011.

**WHERE FASHION AND BEAUTY
COLLIDE ON THE RUNWAY**

THE MARK CONSISTS OF STANDARD CHARACTERS WITHOUT CLAIM TO ANY PARTICULAR FONT, STYLE, SIZE, OR COLOR.

FOR PLANNING AND ORGANIZATION OF SPECIAL EVENTS, SPECIAL EVENTS IN THE NATURE OF PARTIES AND FASHION SHOWS FOR COMMERCIAL PURPOSES, NAMELY, TO PROMOTE THE FASHION AND BEAUTY INDUSTRIES (U.S. CLS. 100, 101 AND 102).

FIRST USE 2-15-2011; IN COMMERCE 2-15-2011.

MICHAEL GAFFAR, EXAMINING ATTORNEY

CLASS 35—(Continued).

SN 85-273,951. WISCOMM, LLC, ELM GROVE, WI. FILED 3-22-2011.



NO CLAIM IS MADE TO THE EXCLUSIVE RIGHT TO USE "COMMUNICATION SOLUTIONS", APART FROM THE MARK AS SHOWN.

THE MARK CONSISTS OF A CIRCLE WITH THE LETTER "W". TO THE RIGHT THERE IS THE STYLIZED TEXT "WISCOMM.COM COMMUNICATION SOLUTIONS".

FOR ON-LINE RETAIL STORE SERVICES FEATURING NEW AND USED COMMUNICATION EQUIPMENTS (U.S. CLS. 100, 101 AND 102).

FIRST USE 1-1-2007; IN COMMERCE 1-1-2007.
ELLEN B. AWRICH, EXAMINING ATTORNEY

SN 85-273,977. PLASTECH SPECIALTIES COMPANY, MONROVIA, CA. FILED 3-22-2011.

MOBISHELF

THE MARK CONSISTS OF STANDARD CHARACTERS WITHOUT CLAIM TO ANY PARTICULAR FONT, STYLE, SIZE, OR COLOR.

FOR ADVERTISING, MARKETING AND PROMOTION SERVICES PROVIDED BY AN AT-SHELF, ELECTRONIC POINT OF PURCHASE ADVERTISING DISPLAY ACCESSED VIA MOBILE TELEPHONE CONNECTIONS AND DEVICES (U.S. CLS. 100, 101 AND 102).

FIRST USE 11-17-2010; IN COMMERCE 1-17-2011.
JENNIFER MARTIN, EXAMINING ATTORNEY

SN 85-273,978. ECTOWNUSA, LLC., QUINCY, CA. FILED 3-22-2011.

ChamberMe

THE MARK CONSISTS OF STANDARD CHARACTERS WITHOUT CLAIM TO ANY PARTICULAR FONT, STYLE, SIZE, OR COLOR.

FOR PROVIDING A WEBSITE FEATURING INFORMATION IN THE FIELD OF CHAMBERS OF COMMERCE AND THE ADVANTAGES OF MEMBERSHIP (U.S. CLS. 100, 101 AND 102).

FIRST USE 3-1-2011; IN COMMERCE 3-1-2011.
LINDA ORNDORFF, EXAMINING ATTORNEY

CLASS 35—(Continued).

SN 85-273,990. HELEN J.C. MATAUSCH, SANTA ROSA, CA. FILED 3-22-2011.

San Frantastico!

THE MARK CONSISTS OF STANDARD CHARACTERS WITHOUT CLAIM TO ANY PARTICULAR FONT, STYLE, SIZE, OR COLOR.

FOR PROMOTING TOURISM IN SAN FRANCISCO AND THE BAY AREA (U.S. CLS. 100, 101 AND 102).

SAMUEL E. SHARPER JR., EXAMINING ATTORNEY

SN 85-274,449. AGENCYRTS, LLC, HOLBROOK, NY. FILED 3-23-2011.

AGENCYRTS

THE MARK CONSISTS OF STANDARD CHARACTERS WITHOUT CLAIM TO ANY PARTICULAR FONT, STYLE, SIZE, OR COLOR.

FOR HUMAN RESOURCES, EMPLOYMENT RECRUITING AND STAFFING CONSULTING SERVICES IN THE FIELDS OF CAREER SERVICES, PLACEMENT, RECRUITMENT, AND CERTIFICATION IN THE INSURANCE AND FINANCIAL SERVICES INDUSTRIES (U.S. CLS. 100, 101 AND 102).

FIRST USE 9-1-2010; IN COMMERCE 9-1-2010.

ELISSA GARBER KON, EXAMINING ATTORNEY

SN 85-274,489. TAL, DAVID, BONITA, CA. FILED 3-23-2011.

HOW CAN I HELP

THE MARK CONSISTS OF STANDARD CHARACTERS WITHOUT CLAIM TO ANY PARTICULAR FONT, STYLE, SIZE, OR COLOR.

FOR PROMOTING THE CHARITABLE SERVICES OF OTHERS, NAMELY, PROVIDING A WEBSITE FEATURING INFORMATION ABOUT VARIOUS CHARITIES FOR THE PURPOSE OF MAKING MONETARY DONATIONS TO CHARITIES (U.S. CLS. 100, 101 AND 102).

ALYSSA STEEL, EXAMINING ATTORNEY

CLASS 35—(Continued).

SN 85-274,554. FILE RIGHT LLC, MIDDLETOWN, DE. FILED 3-23-2011.



THE MARK CONSISTS OF CHECK MARK ON TOP OF THREE STACKED SHADOWED BOXES FOLLOWED BY THE WORDS "FILERIGHT".

FOR PROVIDING ONLINE DIRECTORY INFORMATION, REFERRAL SERVICES FOR IMMIGRATION-RELATED CONSULTANTS AND PROFESSIONALS AND MATCHING SERVICES IN THE NATURE OF MATCHING POTENTIAL CLIENTS TO IMMIGRATION-RELATED CONSULTANTS AND PROFESSIONALS (U.S. CLS. 100, 101 AND 102).

DEIRDRE ROBERTSON, EXAMINING ATTORNEY

SN 85-274,652. BROKEN CHAINZ ENTERTAINMENT, COLUMBUS, OH. FILED 3-23-2011.



NO CLAIM IS MADE TO THE EXCLUSIVE RIGHT TO USE "ENTERTAINMENT", APART FROM THE MARK AS SHOWN.

THE COLOR(S) GRAY IS/ARE CLAIMED AS A FEATURE OF THE MARK.

THE MARK CONSISTS OF THE LETTERS "B" AND "C" OVERLAPPING, WITH THE LETTER "C" SLIGHTLY ROTATED UPSIDE DOWN TO MAKE IT APPEAR AS IF THE "B" AND "C" ARE A BROKEN CHAIN LINK. THE COMPANY NAME "BROKEN CHAINZ ENTERTAINMENT" IS UNDERNEATH THE "B" AND "C" WITH "BROKEN CHAINZ" IN A CURSIVE FONT. THE COLOR OF THE LETTERS IS GRAY.

FOR ENTERTAINMENT MARKETING SERVICES, NAMELY, MARKETING, PROMOTION AND ADVERTISING FOR INDEPENDENT RECORDING ARTISTS (U.S. CLS. 100, 101 AND 102).

FIRST USE 11-1-2009; IN COMMERCE 11-1-2009.
DORITT L. CARROLL, EXAMINING ATTORNEY

CLASS 35—(Continued).

SN 85-274,756. STANDARD FURNITURE COMPANY OF ALA., INC., BIRMINGHAM, AL. FILED 3-23-2011.

MATTRESS LOFT

THE MARK CONSISTS OF STANDARD CHARACTERS WITHOUT CLAIM TO ANY PARTICULAR FONT, STYLE, SIZE, OR COLOR.

NO CLAIM IS MADE TO THE EXCLUSIVE RIGHT TO USE "MATTRESS", APART FROM THE MARK AS SHOWN. FOR RETAIL STORE SERVICES FEATURING SLEEP PRODUCTS, NAMELY, MATTRESSES, SPRING MATTRESSES, SPECIALTY MATTRESSES, ADJUSTABLE MATTRESS BASES, BOX SPRINGS, MATTRESS FOUNDATIONS AND PILLOWS (U.S. CLS. 100, 101 AND 102).

FIRST USE 3-2-2011; IN COMMERCE 3-2-2011.
KARANENDRA S. CHHINA, EXAMINING ATTORNEY

SN 85-275,090. HERMANOS AUTO WHOLESALERS INC. DBA THE CAR SHACK, HIALEAH, FL. FILED 3-23-2011.

The Car Shack

THE MARK CONSISTS OF STANDARD CHARACTERS WITHOUT CLAIM TO ANY PARTICULAR FONT, STYLE, SIZE, OR COLOR.

NO CLAIM IS MADE TO THE EXCLUSIVE RIGHT TO USE "THE CAR", APART FROM THE MARK AS SHOWN. FOR AUTOMOBILE DEALERSHIPS (U.S. CLS. 100, 101 AND 102).

FIRST USE 3-15-1994; IN COMMERCE 3-15-1994.
JEFFERY COWARD, EXAMINING ATTORNEY

CLASS 35—(Continued).

SN 85-275,208. REMY EXCHANGE LLC, AKA REMY EXCHANGE BEAUTY SUPPLY, HOUSTON, TX. FILED 3-24-2011.



OWNER OF U.S. REG. NO. 3,949,595.
NO CLAIM IS MADE TO THE EXCLUSIVE RIGHT TO USE "REMY EXCHANGE BEAUTY SUPPLY", APART FROM THE MARK AS SHOWN.

THE MARK CONSISTS OF A SHADED SQUARE THAT HOLDS THE TEXTUAL MATTER; A BACKWARD "R" AND AN "E". BENEATH THE SQUARE ARE THE WORDS "REMY EXCHANGE BEAUTY SUPPLY".

FOR RETAIL STORE AND ON-LINE RETAIL STORE SERVICES FEATURING BEAUTY SUPPLIES AND EQUIPMENT (U.S. CLS. 100, 101 AND 102).

FIRST USE 8-30-2010; IN COMMERCE 8-30-2010.
MORGAN WYNNE, EXAMINING ATTORNEY

SN 85-275,456. GREATER RICHMOND CHAMBER OF COMMERCE, RICHMOND, VA. FILED 3-24-2011.



NO CLAIM IS MADE TO THE EXCLUSIVE RIGHT TO USE "RICHMOND", APART FROM THE MARK AS SHOWN.

THE MARK CONSISTS OF THE WORDS "SAVE LOW FARES RICHMOND" IN DISTRESSED-STYLE TEXT WITH SPOTS, PRESENTED IN THREE LINES, WITH THE WORD "SAVE" ON THE FIRST LINE WITH A "S" SUBSTITUTED FOR THE "S" IN "SAVE", ACCOMPANIED BY THE OUTLINE OF AN AIRPLANE DIAGONALLY PLACED WITH DISTRESSED-STYLE SPOTS INSIDE OF A CIRCLE WITH DISTRESSED-STYLE SPOTS, AND THE WORDS "LOW FARES" ON THE SECOND LINE, WITH THE WORD "FARES" PARTIALLY OVERLAPPED BY THE AIRPLANE INSIDE THE CIRCLE, AND THE WORD "RICHMOND" ON THE THIRD LINE.

FOR PUBLIC RELATIONS SERVICES, NAMELY, PROMOTING THE SERVICES OF DISCOUNT AIRLINE CARRIERS THROUGH PRINT AND VIDEO ADVERTISING; CONDUCTING PROMOTIONAL CAMPAIGNS FOR DISCOUNT AIRLINE CARRIERS (U.S. CLS. 100, 101 AND 102).

FIRST USE 1-18-2011; IN COMMERCE 1-18-2011.
PRISCILLA MILTON, EXAMINING ATTORNEY

CLASS 35—(Continued).

SN 85-275,909. XTREME POWER INC., KYLE, TX. FILED 3-24-2011.

THE POWER TO CONTROL

THE MARK CONSISTS OF STANDARD CHARACTERS WITHOUT CLAIM TO ANY PARTICULAR FONT, STYLE, SIZE, OR COLOR.

FOR BUSINESS SERVICES, NAMELY, OPERATION OF POWER GENERATION AND POWER STORAGE EQUIPMENT IN THE NATURE OF INTEGRATED ENERGY STORAGE SYSTEMS AND POWER MANAGEMENT SYSTEMS FOR OTHERS (U.S. CLS. 100, 101 AND 102).

JAMES LOVELACE, EXAMINING ATTORNEY

SN 85-276,034. XTREME POWER INC., KYLE, TX. FILED 3-24-2011.

DPR

THE MARK CONSISTS OF STANDARD CHARACTERS WITHOUT CLAIM TO ANY PARTICULAR FONT, STYLE, SIZE, OR COLOR.

FOR BUSINESS SERVICES, NAMELY, OPERATION OF POWER GENERATION AND POWER STORAGE EQUIPMENT IN THE NATURE OF INTEGRATED ENERGY STORAGE SYSTEMS AND POWER MANAGEMENT SYSTEMS FOR OTHERS (U.S. CLS. 100, 101 AND 102).

JAMES LOVELACE, EXAMINING ATTORNEY

SN 85-276,124. SNACKME, LLC, CHICAGO, IL. FILED 3-24-2011.



NO CLAIM IS MADE TO THE EXCLUSIVE RIGHT TO USE "CONVENIENT", "HEALTHY" AND "DELIVERED", APART FROM THE MARK AS SHOWN.

THE COLOR(S) PURPLE, ORANGE, GREEN AND WHITE IS/ARE CLAIMED AS A FEATURE OF THE MARK.

THE MARK CONSISTS OF A DESIGN THAT INCLUDES THE WORDS "SNACKME.COM" WITH THE "S" IN AND "M" IN UPPERCASE LETTERS AND "CONVENIENT", "HEALTHY", "DELIVERED", WITH COMMAS, WITH THE

CLASS 35—(Continued).

WORD "SNACK" IN PURPLE, THE "ME" PART OF "SNACKME.COM" IN ORANGE AND THE ".COM" PORTION, IN SCRIPT, IN WHITE INSIDE A LIGHT GREEN APPLE, WHICH HAS WITHIN IT TO THE UPPER RIGHT A FIGURE THAT RESEMBLES AN EIGHTH OF A MOON FACING LEFT, AND THE STEM OF THE APPLE IS ORANGE EXCEPT FOR SOME WHITE LINES AT ITS TOP, WITH THE WORDS "CONVENIENT," "HEALTHY," AND "DELIVERED" IN PURPLE DIRECTLY UNDER THE WORDS "SNACKME.COM" ON A WHITE BACKGROUND. FOR ON-LINE RETAIL STORE SERVICES FEATURING A DELIVERY SERVICE FOR HEALTH FOOD ITEMS SUCH AS NUTS, BARS, FRUIT AND OTHER RELATED HEALTHY FOOD ITEMS (U.S. CLS. 100, 101 AND 102).

CAROLYN CATALDO, EXAMINING ATTORNEY

CLASS 35—(Continued).

SN 85-276,536. KATHLEEN A. HALL, CLARKESVILLE, GA. FILED 3-25-2011.

MINDFUL LIVING MARKET

THE MARK CONSISTS OF STANDARD CHARACTERS WITHOUT CLAIM TO ANY PARTICULAR FONT, STYLE, SIZE, OR COLOR.

OWNER OF U.S. REG. NOS. 3,674,694, 3,849,081 AND OTHERS.

NO CLAIM IS MADE TO THE EXCLUSIVE RIGHT TO USE "MARKET", APART FROM THE MARK AS SHOWN.

FOR ONLINE RETAIL STORE SERVICES FEATURING BOOKS, CDS, DVDS, JEWELRY, CARDS, JOURNALS FOR PERSONAL REFLECTION, WOODEN GIFT BOXES, BLANKETS, CLOTHING, AND OTHER GIFT ITEMS IN THE FIELD OF PERSONAL SPIRITUAL GROWTH, AND HEALING AND WELLNESS (U.S. CLS. 100, 101 AND 102).

TARA PATE, EXAMINING ATTORNEY

SN 85-276,349. GREG FIELD MARKETING LLC, MESA, AZ. FILED 3-24-2011.

Build It Green Team

THE MARK CONSISTS OF STANDARD CHARACTERS WITHOUT CLAIM TO ANY PARTICULAR FONT, STYLE, SIZE, OR COLOR.

NO CLAIM IS MADE TO THE EXCLUSIVE RIGHT TO USE "BUILD IT GREEN", APART FROM THE MARK AS SHOWN.

FOR CONSULTING SERVICES IN THE FIELD OF ENERGY USAGE MANAGEMENT AND ENERGY EFFICIENCY (U.S. CLS. 100, 101 AND 102).

FIRST USE 3-1-2011; IN COMMERCE 3-1-2011.

MICHAEL TANNER, EXAMINING ATTORNEY

SN 85-276,622. RUG DOCTOR, INC., PLANO, TX. FILED 3-25-2011.

MIGHTY PRO X3

SN 85-276,431. ELI S. ASHER, WESTLAKE, OH. FILED 3-24-2011.

WELLDAYS

THE MARK CONSISTS OF STANDARD CHARACTERS WITHOUT CLAIM TO ANY PARTICULAR FONT, STYLE, SIZE, OR COLOR.

FOR WELLNESS SERVICES IN THE NATURE OF PROVIDING ASSISTANCE, FITNESS EVALUATION AND CONSULTATION TO CORPORATE CLIENTS TO HELP THEIR EMPLOYEES MAKE HEALTH, WELLNESS AND NUTRITIONAL CHANGES IN THEIR DAILY LIVING TO INCREASE PRODUCTIVITY AND LOWER HEALTH CARE COSTS (U.S. CLS. 100, 101 AND 102).

MICHAEL TANNER, EXAMINING ATTORNEY

THE MARK CONSISTS OF STANDARD CHARACTERS WITHOUT CLAIM TO ANY PARTICULAR FONT, STYLE, SIZE, OR COLOR.

OWNER OF U.S. REG. NOS. 2,475,799 AND 2,747,284.

NO CLAIM IS MADE TO THE EXCLUSIVE RIGHT TO USE "PRO", APART FROM THE MARK AS SHOWN.

FOR RETAIL STORE AND ON-LINE RETAIL STORE SERVICES FEATURING CARPET CLEANING MACHINES AND PRODUCTS THAT CLEAN AND REMOVE ALL FOREIGN MATTER FROM RUGS, CARPETING, UPHOLSTERY, FURNITURE, FLOORS, CEILING, WALLS AND OTHER TEXTILES OR FIBROUS FABRIC OR MATERIALS (U.S. CLS. 100, 101 AND 102).

ALICE BENMAMAN, EXAMINING ATTORNEY

CLASS 35—(Continued).

SN 85-276,646. RUG DOCTOR, INC., PLANO, TX. FILED 3-25-2011.

X3

THE MARK CONSISTS OF STANDARD CHARACTERS WITHOUT CLAIM TO ANY PARTICULAR FONT, STYLE, SIZE, OR COLOR.

FOR RETAIL STORE AND ON-LINE RETAIL STORE SERVICES FEATURING CARPET CLEANING MACHINES AND PRODUCTS THAT CLEAN AND REMOVE ALL FOREIGN MATTER FROM RUGS, CARPETING, UPHOLSTERY, FURNITURE, FLOORS, CEILING, WALLS AND OTHER TEXTILES OR FIBROUS FABRIC OR MATERIALS (U.S. CLS. 100, 101 AND 102).

ALICE BENMAMAN, EXAMINING ATTORNEY

SN 85-276,704. ENCHANTED PLANET, MURFREESBORO, TN. FILED 3-25-2011.

Enchanted Planet

THE MARK CONSISTS OF STANDARD CHARACTERS WITHOUT CLAIM TO ANY PARTICULAR FONT, STYLE, SIZE, OR COLOR.

FOR RETAIL GIFT SHOPS (U.S. CLS. 100, 101 AND 102).

FIRST USE 10-7-1994; IN COMMERCE 10-7-1994.
EDWARD NELSON, EXAMINING ATTORNEY

SN 85-277,270. RAGARCA GROUP OF AMERICA INC., DORAL, FL. FILED 3-25-2011.

RGA

THE MARK CONSISTS OF STANDARD CHARACTERS WITHOUT CLAIM TO ANY PARTICULAR FONT, STYLE, SIZE, OR COLOR.

FOR WHOLESALE AND RETAIL STORE SERVICES FEATURING AUTO-PARTS (U.S. CLS. 100, 101 AND 102).

DEZMONA MIZELLE, EXAMINING ATTORNEY

CLASS 35—(Continued).

SN 85-277,385. RAGARCA GROUP OF AMERICA INC., DORAL, FL. FILED 3-25-2011.

AFK

THE MARK CONSISTS OF STANDARD CHARACTERS WITHOUT CLAIM TO ANY PARTICULAR FONT, STYLE, SIZE, OR COLOR.

FOR WHOLESALE AND RETAIL STORE SERVICES FEATURING AUTO-PARTS (U.S. CLS. 100, 101 AND 102).

DEZMONA MIZELLE, EXAMINING ATTORNEY

SN 85-277,409. AMERICAN PUBLIC POWER ASSOCIATION, WASHINGTON, DC. FILED 3-25-2011.



NO CLAIM IS MADE TO THE EXCLUSIVE RIGHT TO USE "PRODUCT STORE", APART FROM THE MARK AS SHOWN.

THE MARK CONSISTS OF THE WORDS "APPA PRODUCT STORE" ON A BACKGROUND OF TWELVE CONNECTED SQUARES AND THE WORDS "YOUR ONE-STOP SHOP FOR ALL THINGS PUBLIC POWER" ON THE BOTTOM.

FOR COMPUTERIZED ON-LINE RETAIL STORE SERVICES FEATURING PRODUCTS IN THE FIELD OF PUBLIC POWER (U.S. CLS. 100, 101 AND 102).

KAREN K. BUSH, EXAMINING ATTORNEY

SN 85-277,590. TRIPLE PUNDIT, LLC, SAN FRANCISCO, CA. FILED 3-25-2011.

TriplePundit

THE MARK CONSISTS OF STANDARD CHARACTERS WITHOUT CLAIM TO ANY PARTICULAR FONT, STYLE, SIZE, OR COLOR.

FOR PROVIDING NEWS AND INFORMATION IN THE FIELD OF SUSTAINABLE BUSINESS VIA A WEBSITE ON THE INTERNET (U.S. CLS. 100, 101 AND 102).

FIRST USE 1-31-2005; IN COMMERCE 1-31-2005.
NICHOLAS ALTREE, EXAMINING ATTORNEY

CLASS 35—(Continued).

SN 85-277,689. MICHAEL L. MCCANN, BARRINGTON, RI. FILED 3-25-2011.

FAME OR LAME

THE MARK CONSISTS OF STANDARD CHARACTERS WITHOUT CLAIM TO ANY PARTICULAR FONT, STYLE, SIZE, OR COLOR.

FOR PROVIDING AN ONLINE INTERACTIVE WEBSITE FEATURING CONSUMER INFORMATION IN THE NATURE OF USERS' COMMENTS CONCERNING BUSINESS ORGANIZATIONS, SERVICE PROVIDERS, AND OTHER CONSUMER RESOURCES; PROVIDING CONSUMER INFORMATION, NAMELY, COMPILATIONS, RANKINGS, RATINGS, REVIEWS, REFERRALS AND RECOMMENDATIONS RELATING TO BUSINESS ORGANIZATIONS, SERVICE PROVIDERS, AND OTHER CONSUMER RESOURCES USING A GLOBAL COMPUTER NETWORK (U.S. CLS. 100, 101 AND 102).

HEATHER THOMPSON, EXAMINING ATTORNEY

CLASS 35—(Continued).

SN 85-278,352. INSITUM CONSULTING LLC, DBA INSITUM, EVANSTON, IL. FILED 3-28-2011.

IN/SITUM

THE MARK CONSISTS OF STANDARD CHARACTERS WITHOUT CLAIM TO ANY PARTICULAR FONT, STYLE, SIZE, OR COLOR.

FOR BRANDING SERVICES, NAMELY, CONSULTING, DEVELOPMENT, MANAGEMENT AND MARKETING OF BRANDS FOR BUSINESSES; BUSINESS CONSULTATION AND MANAGEMENT REGARDING MARKETING ACTIVITIES AND LAUNCHING OF NEW PRODUCTS; BUSINESS CONSULTATION IN THE FIELD OF INNOVATION; BUSINESS CONSULTING IN THE CONSUMER PRODUCTS INDUSTRY; BUSINESS RESEARCH USING FOCUS GROUPS; BUSINESS SERVICES, NAMELY, CONSUMER RESEARCH AND CONSULTING RELATED THERETO; CONSUMER MARKETING RESEARCH AND CONSULTING RELATED THERETO; CONSUMER RESEARCH (U.S. CLS. 100, 101 AND 102).

FIRST USE 10-2-2005; IN COMMERCE 10-2-2005.
GRETTA YAO, EXAMINING ATTORNEY

SN 85-278,801. BRANNAN, SION, SANTEE, CA. FILED 3-28-2011.

SN 85-277,752. EXIGENT INNOVATIONS, INC., ALBANY, NY. FILED 3-26-2011.

EXIGENT

THE MARK CONSISTS OF STANDARD CHARACTERS WITHOUT CLAIM TO ANY PARTICULAR FONT, STYLE, SIZE, OR COLOR.

FOR BUSINESS RESEARCH AND ANALYSIS IN THE FIELD OF BUSINESS INNOVATION (U.S. CLS. 100, 101 AND 102).

FIRST USE 1-14-2011; IN COMMERCE 1-14-2011.
CARYN GLASSER, EXAMINING ATTORNEY

REDCON1 TACTICAL

THE MARK CONSISTS OF STANDARD CHARACTERS WITHOUT CLAIM TO ANY PARTICULAR FONT, STYLE, SIZE, OR COLOR.

NO CLAIM IS MADE TO THE EXCLUSIVE RIGHT TO USE "TACTICAL", APART FROM THE MARK AS SHOWN.

FOR RETAIL STORE AND ON-LINE RETAIL STORE SERVICES FEATURING FIREARMS, GUNS, GUN PARTS, RIFLES AND PARTS THEREOF, PISTOLS AND PARTS THEREOF, REVOLVERS AND PARTS THEREOF, AMMUNITION, FIREARM SLINGS, SLING STRAPS FOR FIREARMS, FIREARM ATTACHMENTS, NAMELY, MOUNTS FOR ATTACHING ANCILLARY EQUIPMENT TO A FIREARM (U.S. CLS. 100, 101 AND 102).

JOHN SCHUYLER YARD, EXAMINING ATTORNEY

CLASS 35—(Continued).

SN 85-278,839. GREEN WORLD ENTERPRISES, INC., CAPITAL HEIGHTS, MD. FILED 3-28-2011.

BESTWAY MUNDO LATINO

THE MARK CONSISTS OF STANDARD CHARACTERS WITHOUT CLAIM TO ANY PARTICULAR FONT, STYLE, SIZE, OR COLOR.

NO CLAIM IS MADE TO THE EXCLUSIVE RIGHT TO USE "LATINO", APART FROM THE MARK AS SHOWN.

THE ENGLISH TRANSLATION OF "MUNDO LATINO" IN THE MARK IS LATIN WORLD.

FOR RETAIL GROCERY STORES (U.S. CLS. 100, 101 AND 102).

FIRST USE 0-0-2002; IN COMMERCE 0-0-2002.

ANTHONY RINKER, EXAMINING ATTORNEY

SN 85-278,975. GULDA, EDWARD J, WATERFORD, MI. FILED 3-28-2011.

FJC Enterprises

THE MARK CONSISTS OF STANDARD CHARACTERS WITHOUT CLAIM TO ANY PARTICULAR FONT, STYLE, SIZE, OR COLOR.

NO CLAIM IS MADE TO THE EXCLUSIVE RIGHT TO USE "ENTERPRISES", APART FROM THE MARK AS SHOWN.

FOR CORPORATE MANAGEMENT ASSISTANCE (U.S. CLS. 100, 101 AND 102).

FIRST USE 2-13-2011; IN COMMERCE 2-13-2011.

SCOTT BIBB, EXAMINING ATTORNEY

CLASS 35—(Continued).

SN 85-279,078. BRAND.NET, INC., SAN MATEO, CA. FILED 3-28-2011.

MFP ON DEMAND

THE MARK CONSISTS OF STANDARD CHARACTERS WITHOUT CLAIM TO ANY PARTICULAR FONT, STYLE, SIZE, OR COLOR.

NO CLAIM IS MADE TO THE EXCLUSIVE RIGHT TO USE "ON DEMAND", APART FROM THE MARK AS SHOWN.

FOR ADVERTISING AND PROMOTION SERVICES AND RELATED CONSULTING; ADVERTISING SERVICES, NAMELY, PROMOTING AND MARKETING THE GOODS AND SERVICES OF OTHERS THROUGH ALL PUBLIC COMMUNICATION MEANS; ADVERTISING BY TRANSMISSION OF ON-LINE PUBLICITY FOR THIRD PARTIES THROUGH ELECTRONIC COMMUNICATIONS NETWORKS; PREPARATION AND REALIZATION OF MEDIA AND ADVERTISING PLANS AND CONCEPTS; RENTAL OF ADVERTISING SPACE ON WEB SITES; ADVERTISING CONSULTING SERVICES, NAMELY, PROVIDING ADVERTISING PRICING AND INVENTORY INFORMATION; ADVERTISING CONSULTING SERVICES, NAMELY, PLACING ONLINE ADVERTISEMENTS FOR OTHERS (U.S. CLS. 100, 101 AND 102).

EDWARD FENNESSY, EXAMINING ATTORNEY

SN 85-279,181. DUGARD, WILLIAM, LENEXA, KS. FILED 3-28-2011.

AFFIRMATIONAL LEADERSHIP

THE MARK CONSISTS OF STANDARD CHARACTERS WITHOUT CLAIM TO ANY PARTICULAR FONT, STYLE, SIZE, OR COLOR.

NO CLAIM IS MADE TO THE EXCLUSIVE RIGHT TO USE "LEADERSHIP", APART FROM THE MARK AS SHOWN.

FOR CONSULTING SERVICES IN BUSINESS LEADERSHIP DEVELOPMENT AND BUSINESS MANAGEMENT (U.S. CLS. 100, 101 AND 102).

FIRST USE 1-1-2009; IN COMMERCE 5-5-2009.

HOWARD B. LEVINE, EXAMINING ATTORNEY

CLASS 35—(Continued).

SN 85-279,394. C.A. MARKETING, INC., MIAMI, FL. FILED 3-29-2011.

ShopperPak

THE MARK CONSISTS OF STANDARD CHARACTERS WITHOUT CLAIM TO ANY PARTICULAR FONT, STYLE, SIZE, OR COLOR.

FOR DIRECT MAIL ADVERTISING SERVICES; PROMOTING THE GOODS AND SERVICES OF OTHERS BY DISTRIBUTING ADVERTISING MATERIALS THROUGH A VARIETY OF METHODS; PROMOTING THE GOODS AND SERVICES OF OTHERS VIA A GLOBAL COMPUTER NETWORK (U.S. CLS. 100, 101 AND 102).

FIRST USE 4-12-2010; IN COMMERCE 1-4-2011.
NORA BUCHANAN WILL, EXAMINING ATTORNEY

CLASS 35—(Continued).

SN 85-280,635. WAL-MART STORES, INC., BENTONVILLE, AR. FILED 3-29-2011.



THE MARK CONSISTS OF THE LETTERS "AM" IN STYLIZED FORM INSIDE A CARRIER OF CONCENTRIC CIRCLES. THE CIRCLE IS COMPOSED OF A THIN OUTER RING AND INSIDE THERE IS AN EFFECT OF A METALLIC POLISH OR SHINE.

FOR ON-LINE RETAIL STORE SERVICES FEATURING A WIDE VARIETY OF CONSUMER GOODS OF OTHERS; RETAIL DEPARTMENT STORE SERVICES; RETAIL STORE SERVICES FEATURING A WIDE VARIETY OF CONSUMER GOODS OF OTHERS (U.S. CLS. 100, 101 AND 102).

CORY BOONE, EXAMINING ATTORNEY

SN 85-279,619. NEW BENEFITS, LTD., DALLAS, TX. FILED 3-29-2011.

LEADER OF THE BAC

NO CLAIM IS MADE TO THE EXCLUSIVE RIGHT TO USE "CARD", APART FROM THE MARK AS SHOWN.

THE MARK CONSISTS OF TWO BLOCK LETTER "C", ONE FACING RIGHT AND ONE POSITIONED ON TOP TO CREATE A DIMENSIONAL CUBE, FOLLOWED BY THE PHRASE "CARRY THE CARD" IN TEXT.

FOR CONSUMER BENEFITS, NAMELY, ADMINISTRATION OF A DISCOUNT PROGRAM FOR ENABLING PARTICIPANTS TO OBTAIN DISCOUNTS ON GOODS AND SERVICES OF OTHERS THROUGH THE USE OF A DISCOUNT MEMBERSHIP CARD AT THE POINT OF SERVICE FOR GENERAL HEALTHCARE SUPPLIES AND LIFESTYLE BENEFITS (U.S. CLS. 100, 101 AND 102).

DEZMONA MIZELLE, EXAMINING ATTORNEY

SN 85-281,089. BATH & BODY WORKS BRAND MANAGEMENT, INC., REYNOLDSBURG, OH. FILED 3-30-2011.

THE MARK CONSISTS OF STANDARD CHARACTERS WITHOUT CLAIM TO ANY PARTICULAR FONT, STYLE, SIZE, OR COLOR.

FOR RETAIL STORE SERVICES IN THE FIELD OF PERSONAL CARE AND HOME FRAGRANCE PRODUCTS AND ACCESSORIES FEATURING AN INCENTIVE AWARD PROGRAM FOR CUSTOMERS TO PROMOTE THE SALE OF PERSONAL CARE AND HOME FRAGRANCE PRODUCTS AND SERVICES (U.S. CLS. 100, 101 AND 102).

BARBARA RUTLAND, EXAMINING ATTORNEY

CLASS 35—(Continued).

SN 85-281,287. HOOVER'S, INC., AUSTIN, TX. FILED 3-30-2011.

MAKE US YOUR PARTNER. WE
MAKE YOUR WORK EASIER.

THE MARK CONSISTS OF STANDARD CHARACTERS WITHOUT CLAIM TO ANY PARTICULAR FONT, STYLE, SIZE, OR COLOR.

FOR PROVIDING A WEB SITE FEATURING A WIDE VARIETY OF BUSINESS RESEARCH INFORMATION RELATED TO CURRENT BUSINESS NEWS, COMPANY AND INDUSTRY PROFILES, INVESTMENT INFORMATION, JOB SEARCHES, AND RELATED BUSINESS MATTERS; PREPARING MAILING LISTS; BUSINESS MARKETING SERVICES; PROVIDING BUSINESS LEAD GENERATION ACTIVITIES AND SERVICES; CUSTOMER RELATIONSHIP MANAGEMENT SERVICES; AND SALES PROMOTION SERVICES (U.S. CLS. 100, 101 AND 102).

FIRST USE 3-15-2011; IN COMMERCE 3-15-2011.
MARK T. MULLEN, EXAMINING ATTORNEY

SN 85-281,895. MONA TERRELL & ASSOCIATES LLC, PISCATAWAY, NJ. FILED 3-30-2011.

More Than Magic

THE MARK CONSISTS OF STANDARD CHARACTERS WITHOUT CLAIM TO ANY PARTICULAR FONT, STYLE, SIZE, OR COLOR.

FOR PROMOTING PUBLIC AWARENESS OF HIV-AIDS (U.S. CLS. 100, 101 AND 102).

TAMARA FRAZIER, EXAMINING ATTORNEY

CLASS 35—(Continued).

SN 85-282,260. LILISE, LLC, CONCORD, NH. FILED 3-31-2011.



NO CLAIM IS MADE TO THE EXCLUSIVE RIGHT TO USE "DESIGNER RESALE", APART FROM THE MARK AS SHOWN.

THE COLOR(S) BLACK, WHITE, GRAY AND GOLD IS/ ARE CLAIMED AS A FEATURE OF THE MARK.

THE MARK CONSISTS OF STYLIZED WRITING OF "LILISE" IN BLACK AND IN A SLIGHTLY SMALLER FONT "DESIGNER RESALE" IN BLACK; TO THE RIGHT OF THE WORDS IS A WOMAN DRESSED IN EARLY 1900'S CLOTHING IN GRAY WITH WHITE STOCKINGS AND BLACK SHOES; LOOKING OVER HER SHOULDER WITH A GOLD PLUME ON HER BLACK HAT WITH BLACK AND WHITE TRIM, A GOLD WALKING CANE, GOLD BUTTONS AND GOLD TRIM ON HER SHOES.

FOR ON-LINE RETAIL CONSIGNMENT STORES FEATURING CLOTHING, SHOES, AND ACCESSORIES; RETAIL CONSIGNMENT STORES FEATURING CLOTHING, SHOES AND ACCESSORIES (U.S. CLS. 100, 101 AND 102).

SKYE YOUNG, EXAMINING ATTORNEY

SN 85-283,244. PETIT, MICHAEL, DBA PETIT PRODUCTIONS, PLAINVILLE, MA. FILED 3-31-2011.

OLE

THE MARK CONSISTS OF STANDARD CHARACTERS WITHOUT CLAIM TO ANY PARTICULAR FONT, STYLE, SIZE, OR COLOR.

FOR RETAIL LAWN, GARDEN AND NURSERY STORES (U.S. CLS. 100, 101 AND 102).

FIRST USE 9-19-2010; IN COMMERCE 10-14-2010.

JUDITH HELFMAN, EXAMINING ATTORNEY

CLASS 35—(Continued).

SN 85-283,852. REED ELSEVIER INC., NEW YORK, NY, AND AMERICAN GAMING ASSOCIATION, WASHINGTON, DC. FILED 4-1-2011.

G2E MOBILE

THE MARK CONSISTS OF STANDARD CHARACTERS WITHOUT CLAIM TO ANY PARTICULAR FONT, STYLE, SIZE, OR COLOR.

OWNER OF U.S. REG. NOS. 2,685,263, 3,416,170 AND OTHERS.

NO CLAIM IS MADE TO THE EXCLUSIVE RIGHT TO USE "MOBILE", APART FROM THE MARK AS SHOWN.

FOR PROVIDING MOBILE SHOWROOMS FOR THE GOODS AND SERVICES OF OTHERS DIRECTED TO THE GAMING AND ENTERTAINMENT INDUSTRIES; PROVIDING BANNER ADVERTISING; DEVELOPMENT OF TEXT MESSAGING MARKETING CAMPAIGNS FOR OTHERS VIA MOBILE DEVICES; PROVIDING ONLINE DIRECTORIES AND A SEARCHABLE ONLINE ADVERTISING GUIDE FEATURING THE GOODS AND SERVICES OF ONLINE VENDORS FOR TRADESHOW EXHIBITIONS DIRECTED TO THE GAMING AND ENTERTAINMENT INDUSTRIES (U.S. CLS. 100, 101 AND 102).

JESSICA A. POWERS, EXAMINING ATTORNEY

CLASS 35—(Continued).

SN 85-286,311. VICTOR SIGN CORPORATION, CHICAGO, IL. FILED S.R. 4-5-2011; AM. P.R. 7-8-2011.

Victor Sign Chicago's Original Billboard Company

THE MARK CONSISTS OF STANDARD CHARACTERS WITHOUT CLAIM TO ANY PARTICULAR FONT, STYLE, SIZE, OR COLOR.

NO CLAIM IS MADE TO THE EXCLUSIVE RIGHT TO USE "SIGN CHICAGO'S ORIGINAL BILLBOARD COMPANY", APART FROM THE MARK AS SHOWN.

FOR PREPARING AND PLACING OUTDOOR ADVERTISEMENTS FOR OTHERS (U.S. CLS. 100, 101 AND 102). FIRST USE 3-1-2011; IN COMMERCE 3-1-2011.

LOURDES AYALA, EXAMINING ATTORNEY

SN 85-286,592. HOOVER'S, INC., AUSTIN, TX. FILED 4-5-2011.

SN 85-285,897. WIN-STARK, LLC, WILMER, TX. FILED 4-4-2011.



FIRST AID, SURVIVAL KITS, EMERGENCY RATIONS AND MORE
888.872.8189 WWW.THESURVIVALBUREAU.COM

NO CLAIM IS MADE TO THE EXCLUSIVE RIGHT TO USE "SURVIVAL" AND "FIRST AID SURVIVAL KITS EMERGENCY RATIONS AND MORE 888 872 8189", APART FROM THE MARK AS SHOWN.

THE MARK CONSISTS OF A SHIELD WITH THE WORDS "SURVIVAL BUREAU" WITH AN OUTLINE AND BENEATH THE WORDS "FIRST AID, SURVIVAL KITS, EMERGENCY RATIONS AND MORE", FOLLOWED BY "888.872.8189 WWW.THESURVIVALBUREAU.COM".

FOR ON-LINE RETAIL STORE SERVICES FEATURING FIRST AID, SURVIVAL KITS AND ACCESSORIES (U.S. CLS. 100, 101 AND 102).

BRIDGETT SMITH, EXAMINING ATTORNEY

RESEARCHER

THE MARK CONSISTS OF STANDARD CHARACTERS WITHOUT CLAIM TO ANY PARTICULAR FONT, STYLE, SIZE, OR COLOR.

FOR PROVIDING AN ON-LINE COMPUTER DATABASE IN THE FIELD OF BUSINESS INFORMATION RELATED TO CURRENT BUSINESS NEWS, COMPANY AND INDUSTRY PROFILES, INVESTMENT INFORMATION, JOB SEARCHES, AND RELATED BUSINESS MATTERS; PREPARING MAILING LISTS; BUSINESS MARKETING SERVICES; PROVIDING BUSINESS LEAD GENERATION ACTIVITIES AND SERVICES; CUSTOMER RELATIONSHIP MANAGEMENT SERVICES; AND SALES PROMOTION SERVICES (U.S. CLS. 100, 101 AND 102).

FIRST USE 11-3-2008; IN COMMERCE 11-3-2008.

MARK T. MULLEN, EXAMINING ATTORNEY

CLASS 35—(Continued).

SN 85-287,357. ARTS THREAD LTD., LONDON, ENGLAND, FILED 4-6-2011.



NO CLAIM IS MADE TO THE EXCLUSIVE RIGHT TO USE "ARTS", APART FROM THE MARK AS SHOWN.

THE MARK CONSISTS OF THE WORDS "ARTS THREAD" IN STYLIZED LETTERS, WITH GEOMETRICAL FIGURES OF A SQUARE, CIRCLE, POLYGON, AND TRIANGLE ALIGNED AT THE UPPER LEFT CORNER.

FOR ADVERTISEMENT FOR OTHERS ON THE INTERNET; ADVERTISING AGENCIES, NAMELY, PROMOTING THE GOODS AND SERVICES OF OTHERS; ADVERTISING AND COMMERCIAL INFORMATION SERVICES, VIA THE INTERNET; ADVERTISING AND DIRECTORY SERVICES, NAMELY, PROMOTING THE SERVICES OF OTHERS BY PROVIDING A WEB PAGE FEATURING LINKS TO THE WEBSITES OF OTHERS; ADVERTISING AND MARKETING SERVICES, NAMELY, PROMOTING THE GOODS AND SERVICES OF OTHERS; ADVERTISING AND PROMOTING THE GOODS AND SERVICES OF A VISUAL ARTIST; ADVERTISING AND PUBLICITY SERVICES, NAMELY, PROMOTING THE GOODS, SERVICES, BRAND IDENTITY AND COMMERCIAL INFORMATION AND NEWS OF THIRD PARTIES THROUGH PRINT, AUDIO, VIDEO, DIGITAL AND ON-LINE MEDIUM; ADVERTISING ON THE INTERNET FOR OTHERS; ADVERTISING SERVICES, NAMELY, PROMOTING THE BRANDS, GOODS AND SERVICES OF OTHERS; ADVERTISING SERVICES, PUBLIC RELATIONS AND MARKETING SERVICES, NAMELY, PROMOTING AND MARKETING THE GOODS AND SERVICES OF OTHERS THROUGH ALL PUBLIC COMMUNICATION MEANS; ADVERTISING VIA ELECTRONIC MEDIA AND SPECIFICALLY THE INTERNET; ADVERTISING, INCLUDING ON-LINE ADVERTISING ON A COMPUTER NETWORK; CONDUCTING, ARRANGING AND ORGANIZING TRADE SHOWS AND TRADE FAIRS FOR COMMERCIAL AND ADVERTISING PURPOSES; DEVELOPMENT OF MARKETING STRATEGIES, CONCEPTS AND TACTICS, NAMELY, AUDIENCE DEVELOPMENT, BRAND AWARENESS, CUSTOMER RELATIONS, ONLINE COMMUNITY BUILDING AND DIGITAL WORD OF MOUTH COMMUNICATIONS; DEVELOPMENT OF MARKETING STRATEGIES, CONCEPTS AND TACTICS, NAMELY, AUDIENCE DEVELOPMENT, BRAND AWARENESS, ONLINE COMMUNITY BUILDING AND DIGITAL WORD OF MOUTH COMMUNICATIONS; ENDORSEMENT SERVICES, NAMELY, PROMOTING THE GOODS AND SERVICES OF OTHERS; EVENT PLANNING AND MANAGEMENT FOR MARKETING, BRANDING, PROMOTING OR ADVERTISING THE GOODS AND SERVICES OF OTHERS; GENERAL BUSINESS NETWORKING REFERRAL SERVICES, NAMELY, PROMOTING THE GOODS AND SERVICES OF OTHERS BY PASSING BUSINESS LEADS AND REFERRALS AMONG GROUP MEMBERS; INFORMATION, ADVISORY, CONSULTING, BUSINESS RESEARCH AND PLANNING SERVICES RELATING TO PUBLICITY, MARKETING COMMUNICATIONS, REPUTATION MANAGEMENT OR BUSINESS ADMINISTRATION, INCLUDING SUCH SERVICES PROVIDED ONLINE OR VIA THE INTERNET; INTERNATIONAL BUSINESS CONSULTING SERVICES RELATING TO MERCHANDISE TRADING, HUMAN RESOURCE INTERCHANGE, MANAGEMENT SUPPORT, MARKETING, ADVERTISING, PROMOTION, AND DOMESTIC AND INTERNATIONAL MARKET RESEARCH AND DEVELOPMENT; INTERNET ADVERTISING SERVICES; MARKETING SERVICES, NAMELY, PROMOTING OR ADVERTISING THE GOODS AND SERVICES OF OTHERS; MEMBERSHIP CLUB SERVICES, NAMELY, PROVIDING ON-LINE INFORMATION TO MEMBERS IN THE FIELDS OF BRANDING, BUSINESS DEVELOPMENT, BUSINESS MARKETING,

CLASS 35—(Continued).

AND MARKETING; ON-LINE ADVERTISING AND MARKETING SERVICES; ON-LINE ADVERTISING ON COMPUTER NETWORKS; ON-LINE ADVERTISING SERVICES FOR OTHERS; ONLINE ADVERTISING AND PROMOTIONAL SERVICES; ORGANISATION OF EXHIBITIONS AND TRADE FAIRS FOR BUSINESS AND PROMOTIONAL PURPOSES; PROMOTING AND CONDUCTING TRADE SHOWS IN THE FIELD OF DESIGN; PROMOTING THE GOODS AND SERVICES OF OTHERS BY PREPARING AND PLACING ADVERTISEMENTS IN AN ELECTRONIC MAGAZINE ACCESSED THROUGH A GLOBAL COMPUTER NETWORK; PROMOTING THE GOODS AND SERVICES OF OTHERS BY PROVIDING A WEB SITE AT WHICH USERS CAN LINK TO DESIGNER'S WORKS; PROMOTING THE GOODS AND SERVICES OF OTHERS VIA A GLOBAL COMPUTER NETWORK; PROMOTING THE GRAPHIC ARTS DESIGN SERVICES OF OTHERS BY MEANS OF A WEBSITE FEATURING GRAPHIC ARTWORK SUBMITTED BY GRAPHIC ART DESIGNERS; PROMOTING VISUAL AND PERFORMING ARTS EVENTS BY MEANS OF PROVIDING AN ONLINE EVENTS CALENDAR, ORIGINAL ARTICLES, INTERVIEWS, AND INFORMATION ABOUT ART, ARTISTS AND ARTS EVENTS VIA AN INTERNET WEB SITE, ALL FOR PROMOTIONAL PURPOSES; PROVIDING A SEARCHABLE ONLINE ADVERTISING WEBSITE AND INFORMATIONAL GUIDE FEATURING THE GOODS AND SERVICES OF OTHER VENDORS VIA THE INTERNET IN THE FIELD OF DESIGN; PROVISION OF SPACE ON WEBSITES FOR ADVERTISING GOODS AND SERVICES (U.S. CLS. 100, 101 AND 102).

TEJBIR SINGH, EXAMINING ATTORNEY

SN 85-287,561. GREATER FORT LAUDERDALE ALLIANCE, FORT LAUDERDALE, FL. FILED 4-6-2011.

Life. Less Taxing.

THE MARK CONSISTS OF STANDARD CHARACTERS WITHOUT CLAIM TO ANY PARTICULAR FONT, STYLE, SIZE, OR COLOR.

FOR ADVERTISING AND MARKETING SERVICES FOR ORGANIZATIONS THAT ENCOURAGE ECONOMIC GROWTH AND BUSINESS DEVELOPMENT IN BROWARD COUNTY, FLORIDA (U.S. CLS. 100, 101 AND 102).

FIRST USE 1-16-2011; IN COMMERCE 1-16-2011.
JUSTINE D. PARKER, EXAMINING ATTORNEY

CLASS 35—(Continued).

SN 85-287,650. EXTRA VIRGIN, AN OLIVE OVATION, LLC, CLAYTON, MO. FILED 4-6-2011.

AN OLIVE OVATION

THE MARK CONSISTS OF STANDARD CHARACTERS WITHOUT CLAIM TO ANY PARTICULAR FONT, STYLE, SIZE, OR COLOR.

NO CLAIM IS MADE TO THE EXCLUSIVE RIGHT TO USE "OLIVE", APART FROM THE MARK AS SHOWN.

FOR RETAIL STORE SERVICES AND ONLINE RETAIL STORE SERVICES FEATURING OLIVES, OLIVE OILS, VINEGARS, SPECIALTY FOODS, SPICES, SPREADS, SAUCES, DESSERTS, AND OLIVE-RELATED NOVELTY ITEMS AND HOUSEWARES (U.S. CLS. 100, 101 AND 102).

FIRST USE 10-0-2007; IN COMMERCE 10-0-2007.
BRENDAN REGAN, EXAMINING ATTORNEY

SN 85-287,684. KASS, DAN, MONTECITO, CA. AND JEPSEN, HELEN, LOMPOC, CA. FILED 4-6-2011.

WHODELICIOUS

THE MARK CONSISTS OF STANDARD CHARACTERS WITHOUT CLAIM TO ANY PARTICULAR FONT, STYLE, SIZE, OR COLOR.

FOR ONLINE RETAIL STORE SERVICES AND RETAIL STORE SERVICES FEATURING BAKED GOODS, CANDY AND SWEETS (U.S. CLS. 100, 101 AND 102).

BRENDAN REGAN, EXAMINING ATTORNEY

SN 85-287,689. KASS, DAN, MONTECITO, CA. AND JEPSEN, HELEN, LOMPOC, CA. FILED 4-6-2011.



THE COLOR(S) WHITE, RED, BEIGE, PURPLE, LIGHT PINK, DARK PINK, BLUE AND GREEN IS/ARE CLAIMED AS A FEATURE OF THE MARK.

THE MARK CONSISTS OF THE STYLIZED LIGHT-PINK WORDING "WHODELICIOUS" HAVING A MEDIUM-WIDTH PURPLE STROKE FOLLOWED BY A THIN LIGHT-PINK STROKE AND FINALLY A THICK DARK-PINK STROKE ON THE OUTERMOST EDGE. A BEIGE-WRAPPED CUPCAKE WITH WHITE FROSTING AND A GREEN-STEMMED RED CHERRY ON TOP DOT THE FIRST "I"; A LARGER MATCHING RED CHERRY WITH A GREEN STEM IS USED AS THE FIRST "O", AND THE WHOLE IMAGE IS OUTLINED IN EXPLODING BLUE LIGHTNING STREAKS.

FOR ONLINE RETAIL STORE SERVICES AND RETAIL STORE SERVICES FEATURING BAKED GOODS, CANDY AND SWEETS (U.S. CLS. 100, 101 AND 102).

BRENDAN REGAN, EXAMINING ATTORNEY

CLASS 35—(Continued).

SN 85-288,459. ARMBRUSTER, ADAM, SARASOTA, FL. FILED 4-7-2011.

ADVERTIMING

THE MARK CONSISTS OF STANDARD CHARACTERS WITHOUT CLAIM TO ANY PARTICULAR FONT, STYLE, SIZE, OR COLOR.

FOR ADVERTISING AND PROMOTIONAL SERVICES (U.S. CLS. 100, 101 AND 102).

FIRST USE 4-1-2010; IN COMMERCE 4-2-2010.
HEATHER SAPP, EXAMINING ATTORNEY

SN 85-288,553. ARNOLD & ASSOCIATES OF WICHITA, INC., WICHITA, KS. FILED 4-7-2011.



OWNER OF U.S. REG. NOS. 2,493,601, 2,493,602 AND 2,672,269.

NO CLAIM IS MADE TO THE EXCLUSIVE RIGHT TO USE "GROUP" AND "A HUMAN RESOURCE COMPANY", APART FROM THE MARK AS SHOWN.

THE MARK CONSISTS OF A HUMAN FIGURE JUGGLING FIVE BALLS TO THE LEFT OF THE WORDS "THE ARNOLD GROUP" AND "A HUMAN RESOURCE COMPANY".

FOR TEMPORARY EMPLOYMENT AGENCIES (U.S. CLS. 100, 101 AND 102).

FIRST USE 8-1-2000; IN COMMERCE 8-1-2000.
JOHN WILKE, EXAMINING ATTORNEY

SN 85-288,648. EDGE OF SEVEN, INC., DENVER, CO. FILED 4-7-2011.



THE MARK CONSISTS OF THE WORDING EDGE OF AND A STYLIZED 7.

FOR CHARITABLE SERVICES, NAMELY, ORGANIZING AND CONDUCTING VOLUNTEER PROGRAMS AND COMMUNITY SERVICE PROJECTS THAT INVEST IN EDUCATION, HEALTH AND ECONOMIC OPPORTUNITY FOR GIRLS IN DEVELOPING COUNTRIES (U.S. CLS. 100, 101 AND 102).

FIRST USE 3-22-2009; IN COMMERCE 3-22-2009.
JOSETTE BEVERLY, EXAMINING ATTORNEY

CLASS 35—(Continued).

SN 85-288,693. HY-VEE, INC., WEST DES MOINES, IA. FILED 4-7-2011.



OWNER OF U.S. REG. NOS. 3,217,660, 3,217,663 AND OTHERS.

THE MARK CONSISTS OF THE DRAWING OF AN APPLE WITH TWO LEAVES AND THE WORDS "HY-VEE MAINSTREET" IN STYLIZED LETTERING APPEARING TO THE RIGHT OF THE DRAWING OF THE APPLE.

FOR RETAIL GROCERY STORES (U.S. CLS. 100, 101 AND 102).

BRIAN CALLAGHAN, EXAMINING ATTORNEY

CLASS 35—(Continued).

SN 85-289,890. BURR, EVAN, NEW YORK, NY. FILED 4-8-2011.

CAMPAIGNOLOGY

THE MARK CONSISTS OF STANDARD CHARACTERS WITHOUT CLAIM TO ANY PARTICULAR FONT, STYLE, SIZE, OR COLOR.

FOR ADVERTISING AND MARKETING CONSULTANCY; ADVERTISING AND MARKETING SERVICES PROVIDED BY MEANS OF INDIRECT METHODS OF MARKETING COMMUNICATIONS, NAMELY, SOCIAL MEDIA, SEARCH ENGINE MARKETING, INQUIRY MARKETING, INTERNET MARKETING, MOBILE MARKETING, BLOGGING AND OTHER FORMS OF PASSIVE, SHARABLE OR VIRAL COMMUNICATIONS CHANNELS (U.S. CLS. 100, 101 AND 102).

FIRST USE 4-1-2011; IN COMMERCE 4-1-2011.

GENE MACIOL, EXAMINING ATTORNEY

SN 85-289,429. KALANI JEWELERS, INC., HEMPSTEAD, NY. FILED 4-7-2011.



NO CLAIM IS MADE TO THE EXCLUSIVE RIGHT TO USE "JEWELERS", APART FROM THE MARK AS SHOWN. THE STIPPLING IS FOR SHADING PURPOSES ONLY.

THE MARK CONSISTS OF THE STYLIZED WORDS "KALANI JEWELERS". THE "K" CONNECTS TO THE "N", UNDER THE LETTERS "ALANI". "JEWELERS" IS WRITTEN IN A SMALLER FONT UNDER THE "ANI" IN THE WORD "KALANI". A DIAMOND FLOATS IN THE TOP CENTER OF THE LOGO.

FOR RETAIL STORE SERVICES FEATURING FINE JEWELRY, NAMELY, GOLD, SILVER, GEMSTONE, AND DIAMOND JEWELRY (U.S. CLS. 100, 101 AND 102).

FIRST USE 7-1-2010; IN COMMERCE 3-7-2011.

GIANCARLO CASTRO, EXAMINING ATTORNEY

SN 85-289,958. KAUFMAN, LAUREL, DBA ELEVATE MY BRAND, SANTA MONICA, CA. FILED 4-8-2011.



THE COLOR(S) PURPLE IS/ARE CLAIMED AS A FEATURE OF THE MARK.

THE MARK CONSISTS OF THE WORDING "ELEVATE MY BRAND" IN PURPLE STYLIZED LETTERING.

FOR ADVERTISING AND MARKETING CONSULTANCY (U.S. CLS. 100, 101 AND 102).

FIRST USE 11-1-2010; IN COMMERCE 2-1-2011.

KATHERINE M. DUBRAY, EXAMINING ATTORNEY

CLASS 35—(Continued).

SN 85-289,985. CUTTING EDGE RECRUITING SOLUTIONS, LLC, BOCA RATON, FL. FILED 4-8-2011.

CERS

THE MARK CONSISTS OF STANDARD CHARACTERS WITHOUT CLAIM TO ANY PARTICULAR FONT, STYLE, SIZE, OR COLOR.

FOR BUSINESS CONSULTING SERVICES IN THE FIELD OF STAFFING AND RECRUITING; CONSULTANCY OF PERSONNEL RECRUITMENT; EMPLOYMENT AGENCY SERVICES; EMPLOYMENT AGENCY SERVICES, NAMELY, FILLING THE TEMPORARY AND PERMANENT STAFFING NEEDS OF BUSINESSES; EMPLOYMENT COUNSELING AND RECRUITING; EMPLOYMENT HIRING, RECRUITING, PLACEMENT, STAFFING AND CAREER NETWORKING SERVICES; EMPLOYMENT OUTPLACEMENT SERVICES; EMPLOYMENT RECRUITING CONSULTATION; EMPLOYMENT STAFFING CONSULTATION SERVICES; PERSONNEL PLACEMENT AND RECRUITMENT; PERSONNEL RECRUITMENT SERVICES AND EMPLOYMENT AGENCIES; PROFESSIONAL STAFFING AND RECRUITING SERVICES; PROVIDING AN EMPLOYER WITH CANDIDATES OR POTENTIAL EMPLOYEES TO FILL TEMPORARY, CONTRACT AND PERMANENT POSITIONS; PROVIDING AN ON-LINE SEARCHABLE DATABASE FEATURING EMPLOYMENT OPPORTUNITIES; PROVIDING AN ON-LINE SEARCHABLE DATABASE FEATURING EMPLOYMENT OPPORTUNITIES AND CONTENT ABOUT EMPLOYMENT; PROVIDING EMPLOYMENT INFORMATION; PROVIDING ON-LINE EMPLOYMENT PLACEMENT SERVICES, NAMELY, MATCHING RESUMES AND POTENTIAL EMPLOYERS VIA A GLOBAL COMPUTER NETWORK; PROVIDING ON-LINE INTERACTIVE EMPLOYMENT COUNSELING AND RECRUITMENT SERVICES; PROVIDING ONLINE DATABASES FEATURING INFORMATION RELATING TO EMPLOYERS AND EMPLOYEES AND PLACES OF EMPLOYMENT; VENDOR MANAGEMENT SERVICES FOR STAFFING AND RECRUITING (U.S. CLS. 100, 101 AND 102).

FIRST USE 10-5-2009; IN COMMERCE 11-0-2009.
LINDA M. KING, EXAMINING ATTORNEY

CLASS 35—(Continued).

SN 85-290,011. CUTTING EDGE RECRUITING SOLUTIONS, LLC, BOCA RATON, FL. FILED 4-8-2011.



THE COLOR(S) BLUE AND GREEN IS/ARE CLAIMED AS A FEATURE OF THE MARK.

THE MARK CONSISTS OF A BLUE-COLORED OPEN CIRCLE WITH A BLUE AND GREEN-COLORED ARROW POINTING AND EXTENDING OUTWARD FROM THE CENTER OF THE CIRCLE.

FOR BUSINESS CONSULTING SERVICES IN THE FIELD OF STAFFING AND RECRUITING; CONSULTANCY OF PERSONNEL RECRUITMENT; EMPLOYMENT AGENCY SERVICES; EMPLOYMENT AGENCY SERVICES, NAMELY, FILLING THE TEMPORARY AND PERMANENT STAFFING NEEDS OF BUSINESSES; EMPLOYMENT COUNSELING AND RECRUITING; EMPLOYMENT HIRING, RECRUITING, PLACEMENT, STAFFING AND CAREER NETWORKING SERVICES; EMPLOYMENT OUTPLACEMENT SERVICES; EMPLOYMENT RECRUITING CONSULTATION; EMPLOYMENT STAFFING CONSULTATION SERVICES; PERSONNEL PLACEMENT AND RECRUITMENT; PERSONNEL RECRUITMENT SERVICES AND EMPLOYMENT AGENCIES; PROFESSIONAL STAFFING AND RECRUITING SERVICES; PROVIDING AN EMPLOYER WITH CANDIDATES OR POTENTIAL EMPLOYEES TO FILL TEMPORARY, CONTRACT AND PERMANENT POSITIONS; PROVIDING AN ON-LINE SEARCHABLE DATABASE FEATURING EMPLOYMENT OPPORTUNITIES; PROVIDING AN ON-LINE SEARCHABLE DATABASE FEATURING EMPLOYMENT OPPORTUNITIES AND CONTENT ABOUT EMPLOYMENT; PROVIDING EMPLOYMENT INFORMATION; PROVIDING ON-LINE EMPLOYMENT PLACEMENT SERVICES, NAMELY, MATCHING RESUMES AND POTENTIAL EMPLOYERS VIA A GLOBAL COMPUTER NETWORK; PROVIDING ON-LINE INTERACTIVE EMPLOYMENT COUNSELING AND RECRUITMENT SERVICES; PROVIDING ONLINE DATABASES FEATURING INFORMATION RELATING TO EMPLOYERS AND EMPLOYEES AND PLACES OF EMPLOYMENT; VENDOR MANAGEMENT SERVICES FOR STAFFING AND RECRUITING (U.S. CLS. 100, 101 AND 102).

FIRST USE 10-5-2009; IN COMMERCE 11-0-2009.
LINDA M. KING, EXAMINING ATTORNEY

CLASS 35—(Continued).

SN 85-290,029. CUTTING EDGE RECRUITING SOLUTIONS, LLC, BOCA RATON, FL. FILED 4-8-2011.

A COMPANY'S FOUNDATION IS
A SOLID STAFF

THE MARK CONSISTS OF STANDARD CHARACTERS WITHOUT CLAIM TO ANY PARTICULAR FONT, STYLE, SIZE, OR COLOR.

FOR BUSINESS CONSULTING SERVICES IN THE FIELD OF STAFFING AND RECRUITING; CONSULTANCY OF PERSONNEL RECRUITMENT; EMPLOYMENT AGENCY SERVICES; EMPLOYMENT AGENCY SERVICES, NAMELY, FILLING THE TEMPORARY AND PERMANENT STAFFING NEEDS OF BUSINESSES; EMPLOYMENT COUNSELING AND RECRUITING; EMPLOYMENT HIRING, RECRUITING, PLACEMENT, STAFFING AND CAREER NETWORKING SERVICES; EMPLOYMENT OUTPLACEMENT SERVICES; EMPLOYMENT RECRUITING CONSULTATION; EMPLOYMENT STAFFING CONSULTATION SERVICES; PERSONNEL PLACEMENT AND RECRUITMENT; PERSONNEL RECRUITMENT SERVICES AND EMPLOYMENT AGENCIES; PROFESSIONAL STAFFING AND RECRUITING SERVICES; PROVIDING AN EMPLOYER WITH CANDIDATES OR POTENTIAL EMPLOYEES TO FILL TEMPORARY, CONTRACT AND PERMANENT POSITIONS; PROVIDING AN ON-LINE SEARCHABLE DATABASE FEATURING EMPLOYMENT OPPORTUNITIES; PROVIDING AN ON-LINE SEARCHABLE DATABASE FEATURING EMPLOYMENT OPPORTUNITIES AND CONTENT ABOUT EMPLOYMENT; PROVIDING EMPLOYMENT INFORMATION; PROVIDING ON-LINE EMPLOYMENT PLACEMENT SERVICES, NAMELY, MATCHING RESUMES AND POTENTIAL EMPLOYERS VIA A GLOBAL COMPUTER NETWORK; PROVIDING ON-LINE INTERACTIVE EMPLOYMENT COUNSELING AND RECRUITMENT SERVICES; PROVIDING ONLINE DATABASES FEATURING INFORMATION RELATING TO EMPLOYERS AND EMPLOYEES AND PLACES OF EMPLOYMENT; VENDOR MANAGEMENT SERVICES FOR STAFFING AND RECRUITING (U.S. CLS. 100, 101 AND 102).

FIRST USE 10-5-2009; IN COMMERCE 11-0-2009.
LINDA M. KING, EXAMINING ATTORNEY

SN 85-290,217. DSD PARTNERS, INC., MIDLOTHIAN, VA. FILED 4-8-2011.

MARGINMAX

THE MARK CONSISTS OF STANDARD CHARACTERS WITHOUT CLAIM TO ANY PARTICULAR FONT, STYLE, SIZE, OR COLOR.

FOR BUSINESS CONSULTING AND BUSINESS STRATEGY DEVELOPMENT SERVICES THAT PROVIDE STRATEGIES TO RETAIL FOOD INDUSTRY IN THE FIELD OF DIRECT STORE DELIVERY (U.S. CLS. 100, 101 AND 102).

JACQUELINE A. LAVINE, EXAMINING ATTORNEY

CLASS 35—(Continued).

SN 85-290,219. SALES DRIVE, LLC, BURR RIDGE, IL. FILED 4-8-2011.

SALESDRIVE

THE MARK CONSISTS OF STANDARD CHARACTERS WITHOUT CLAIM TO ANY PARTICULAR FONT, STYLE, SIZE, OR COLOR.

FOR CONSULTING IN THE FIELD OF SALES METHODS, SALES MANAGEMENT, AND SALES IMPROVEMENT (U.S. CLS. 100, 101 AND 102).

FIRST USE 7-20-2005; IN COMMERCE 7-20-2005.

JACQUELINE A. LAVINE, EXAMINING ATTORNEY

SN 85-290,598. TARJEFT, CHRISTOPHER T, TA LINE.COM, GROSSE POINTE, MI. FILED 4-8-2011.

Line.com

THE MARK CONSISTS OF STANDARD CHARACTERS WITHOUT CLAIM TO ANY PARTICULAR FONT, STYLE, SIZE, OR COLOR.

FOR ADVERTISING AND BUSINESS SERVICES, NAMELY, PROVIDING AN ONLINE WEBSITE WHERE ADVERTISERS, MARKETERS, AND CONTENT PROVIDERS CAN INTERACT WITH USERS FOR ADVERTISING, BRANDING, AND PROMOTING KNOWLEDGE, PRODUCTS, AND SERVICES, AND TRADESHOWS, ON BEHALF OF THEMSELVES AND OTHERS, AND FOR EVALUATING AND RATING THE SAME, ALL THE FOREGOING RELEVANT TO HUMAN ACTIVITIES AFFECTING CLIMATE CHANGE AND RELATED FIELDS (U.S. CLS. 100, 101 AND 102).

JENNIFER MARTIN, EXAMINING ATTORNEY

CLASS 35—(Continued).

SN 85-290,671. TRANSPAC, INC., DBA TRANSPAC IMPORTS, INC., VACAVILLE, CA. FILED 4-8-2011.

FORESIDE

THE MARK CONSISTS OF STANDARD CHARACTERS WITHOUT CLAIM TO ANY PARTICULAR FONT, STYLE, SIZE, OR COLOR.

FOR MAIL ORDER CATALOG SERVICES AND ON-LINE RETAIL STORE SERVICES FEATURING HOME ACCENT PRODUCTS, NAMELY, LAMPS, CHANDELIERS, LUMINARIES, LANTERNS, CANDLES, CANDLE HOLDERS, MIRRORS, WALL DECORATIONS, NON-METAL BINS, CONTAINERS, TABLES, CHAIRS, SIDEBARDS, SHELVES, PLANT STANDS, BENCHES, FURNITURE OF METAL, CLOCKS, BASKETS FOR DOMESTIC USE, PLATES, BOWLS, SERVING PLATTERS, PITCHERS, MUGS, VASES, URNS, CERAMIC FIGURINES, PLANTERS FOR FLOWERS AND PLANTS, BIRD HOUSES, ARTIFICIAL FLOWER WREATHS, ARTIFICIAL FLOWER ARRANGEMENTS, ARTIFICIAL TOPIARIES, GARDEN STAKES, BASKETS, BIRD BATHS, FIGURINES OF STONE, CONCRETE, AND CLAY (U.S. CLS. 100, 101 AND 102).

FIRST USE 1-10-2011; IN COMMERCE 1-10-2011.
MICHELLE DUBOIS, EXAMINING ATTORNEY

CLASS 35—(Continued).

SN 85-290,975. EXPRESS TAG AND TITLE, MONETA, VA. FILED 4-9-2011.

Express Tag and Title

THE MARK CONSISTS OF STANDARD CHARACTERS WITHOUT CLAIM TO ANY PARTICULAR FONT, STYLE, SIZE, OR COLOR.

NO CLAIM IS MADE TO THE EXCLUSIVE RIGHT TO USE "TAG AND TITLE", APART FROM THE MARK AS SHOWN.

FOR STATE VEHICULAR REGISTRATION AND TITLE TRANSFER (U.S. CLS. 100, 101 AND 102).
VERNA BETH RIRIE, EXAMINING ATTORNEY

SN 85-291,019. PACIFIC PEDIATRIC SUPPLY LLC, MURRIETA, CA. FILED 4-9-2011.

PACIFIC PEDIATRIC SUPPLY

THE MARK CONSISTS OF STANDARD CHARACTERS WITHOUT CLAIM TO ANY PARTICULAR FONT, STYLE, SIZE, OR COLOR.

NO CLAIM IS MADE TO THE EXCLUSIVE RIGHT TO USE "PEDIATRIC SUPPLY", APART FROM THE MARK AS SHOWN.

FOR ON-LINE WHOLESALE AND PHYSICAL RETAIL STORE SERVICES FEATURING SPECIAL TOYS, NAMELY, SENSORY INTEGRATION PRODUCTS FOR AUTISTIC AND SPECIAL NEEDS CHILDREN (U.S. CLS. 100, 101 AND 102).

FIRST USE 2-9-2006; IN COMMERCE 2-9-2009.
AMY HELLA, EXAMINING ATTORNEY

SN 85-290,770. TRUSTEDAD, INC., MENLO PARK, CA. FILED 4-8-2011.

TRUSTEDAD

THE MARK CONSISTS OF STANDARD CHARACTERS WITHOUT CLAIM TO ANY PARTICULAR FONT, STYLE, SIZE, OR COLOR.

FOR PROVIDING ADVERTISING AND PROMOTION SERVICES FOR THE GOODS AND SERVICES OF OTHERS, NAMELY, DISSEMINATION AND PLACEMENT OF ELECTRONIC ADVERTISEMENTS AND FACILITATING QUALIFIED REFERRALS, IN THE NATURE OF DIGITAL ADVERTISEMENTS, REGARDING THE GOODS AND SERVICES OF OTHERS; ADVERTISING AND PROMOTIONAL SERVICES; PROMOTING THE GOODS AND SERVICES OF OTHERS VIA A GLOBAL COMPUTER NETWORK; PROVIDING ADVERTISING AND SALE GENERATION SERVICES FOR THE GOODS AND SERVICES OF OTHERS, NAMELY, TRACKING, ADMINISTERING, BILLING, COMPENSATING AND REPORTING OF ELECTRONIC ADVERTISING OR CONSUMER ACTIVITY RELATED TO ELECTRONIC ADVERTISING; PROVIDING ADVERTISEMENTS FOR SELECTION USING AN ON-LINE COMPUTER DATABASE OR AN ON-LINE SEARCHABLE DATABASE FOR THE PURPOSE OF DISSEMINATING AND PLACING ELECTRONIC ADVERTISEMENTS (U.S. CLS. 100, 101 AND 102).

JANICE L. MCMORROW, EXAMINING ATTORNEY

SN 85-291,049. JR MEDIA PROPERTIES, NEW YORK, NY. FILED 4-9-2011.

empowerdavid.com

THE MARK CONSISTS OF STANDARD CHARACTERS WITHOUT CLAIM TO ANY PARTICULAR FONT, STYLE, SIZE, OR COLOR.

FOR CUSTOMER SERVICE CONSULTING SERVICES (U.S. CLS. 100, 101 AND 102).

JAMES STEIN, EXAMINING ATTORNEY

CLASS 35—(Continued).

SN 85-291,058. WELCOMEWELL, NEW YORK, NY. FILED 4-9-2011.



THE MARK CONSISTS OF A SHOPPING CART WHERE IN THE BASKET IS MADE OUT OF A SHAPE SIMILAR TO A "W". THE SHOPPING CART IS LOCATED OVER A GROUND LINE. THE GROUND LINE IS OVER THE WORDING "WELCOMEWELL". THERE ARE CURVED LINES BEHIND THE SHOPPING CART.

FOR AN E-COMMERCE WEBSITE, NAMELY, WEBSITE PROVIDING ON-LINE RETAIL STORE SERVICES FEATURING FURNITURE, BEDDING, ELECTRONIC APPLIANCES, AND ENTERTAINMENT GOODS (U.S. CLS. 100, 101 AND 102).

FIRST USE 6-1-2011; IN COMMERCE 6-1-2011.
JAMES STEIN, EXAMINING ATTORNEY

SN 85-291,235. CALDARA, JESSICA M., GARDEN CITY, NY. FILED 4-10-2011.



NO CLAIM IS MADE TO THE EXCLUSIVE RIGHT TO USE ".COM", APART FROM THE MARK AS SHOWN.

THE COLOR(S) YELLOW, ORANGE, BLACK, RED, BEIGE AND WHITE IS/ARE CLAIMED AS A FEATURE OF THE MARK.

THE MARK CONSISTS OF THE STYLIZED WORD "FAKE" IN RED, "FRANTIC" IN BLACK, AND ".COM" IN RED. THE WORDS "FAKE" AND "FRANTIC" ARE SEPARATED BY A WOMAN WITH YELLOW AND ORANGE HAIR, BEIGE SKIN, RED LIPS, WHITE TEETH AND WEARING A RED SHIRT, IN A YELLOW CIRCLE OUTLINED IN BLACK. THE STYLIZED WORDS "EVERYTHING'S A CRISIS" APPEAR IN BLACK BELOW THE WORD "FRANTIC".

FOR ON-LINE RETAIL STORE SERVICES FEATURING GENERAL CONSUMER MERCHANDISE AND APPAREL (U.S. CLS. 100, 101 AND 102).

VIVIAN MICZNIK FIRST, EXAMINING ATTORNEY

CLASS 35—(Continued).

SN 85-291,285. HAMSARD 3044, LTD., REDDITCH, WORCS., UNITED KINGDOM, FILED 4-11-2011.

Gainsborough Specialist Baths

THE MARK CONSISTS OF STANDARD CHARACTERS WITHOUT CLAIM TO ANY PARTICULAR FONT, STYLE, SIZE, OR COLOR.

NO CLAIM IS MADE TO THE EXCLUSIVE RIGHT TO USE "SPECIALIST BATHS", APART FROM THE MARK AS SHOWN.

FOR RETAIL SERVICES BY DIRECT SOLICITATION BY SALES AGENTS IN THE FIELD OF BATHTUBS (U.S. CLS. 100, 101 AND 102).

FIRST USE 4-7-2007; IN COMMERCE 4-7-2007.
JAMES GRIFFIN, EXAMINING ATTORNEY

SN 85-291,332. DR. ING. H.C. F. PORSCHE AKTIENGESELLSCHAFT, STUTTGART-ZUFFENHAUSEN, FED REP GERMANY, FILED 4-11-2011.

ENGINEERED FOR MAGIC. EVERY DAY.

THE MARK CONSISTS OF STANDARD CHARACTERS WITHOUT CLAIM TO ANY PARTICULAR FONT, STYLE, SIZE, OR COLOR.

FOR RETAIL STORE SERVICES AND DISTRIBUTORSHIP SERVICES FEATURING AUTOMOBILES (U.S. CLS. 100, 101 AND 102).

FIRST USE 3-0-2011; IN COMMERCE 3-0-2011.
FRANK LATTUCA, EXAMINING ATTORNEY

SN 85-291,349. AMERICAN APPAREL & FOOTWEAR ASSOCIATION, ARLINGTON, VA. FILED 4-11-2011.

WE WEAR

THE MARK CONSISTS OF STANDARD CHARACTERS WITHOUT CLAIM TO ANY PARTICULAR FONT, STYLE, SIZE, OR COLOR.

FOR PROMOTING PUBLIC AWARENESS OF THE APPAREL, FOOTWEAR AND SEWN PRODUCTS INDUSTRIES (U.S. CLS. 100, 101 AND 102).

MARK T. MULLEN, EXAMINING ATTORNEY

CLASS 35—(Continued).

SN 85-291,379. FL FOOD LION, INC., SALISBURY, NC. FILED 4-11-2011.

THERE'S ONE PRICE FOR
EVERYTHING. LOW.

THE MARK CONSISTS OF STANDARD CHARACTERS WITHOUT CLAIM TO ANY PARTICULAR FONT, STYLE, SIZE, OR COLOR.

OWNER OF U.S. REG. NO. 2,909,865.
FOR RETAIL GROCERY STORE SERVICES (U.S. CLS. 100, 101 AND 102).

EMILY CARLSEN, EXAMINING ATTORNEY

SN 85-291,473. ASSOCIATION OF ORGAN PROCUREMENT ORGANIZATIONS, VIENNA, VA. FILED 4-11-2011.

aopo
association of
organ procurement organizations

OWNER OF U.S. REG. NO. 2,894,482.
NO CLAIM IS MADE TO THE EXCLUSIVE RIGHT TO USE "ASSOCIATION", APART FROM THE MARK AS SHOWN.

THE MARK CONSISTS OF THE LITERAL ELEMENT "AOPPO" IN LOWER CASE LETTERS STACKED ABOVE THE LITERAL ELEMENT "ASSOCIATION OF ORGAN PROCUREMENT ORGANIZATIONS" IN LOWER CASE LETTERS.

SEC. 2(F) AS TO "ASSOCIATION OF ORGAN PROCUREMENT ORGANIZATIONS".

FOR ASSOCIATION SERVICES, NAMELY, PROMOTING THE INTERESTS OF THOSE CONCERNED WITH ORGAN AND TISSUE DONATION (U.S. CLS. 100, 101 AND 102).

FIRST USE 8-25-2010; IN COMMERCE 8-25-2010.
LOURDES AYALA, EXAMINING ATTORNEY

CLASS 35—(Continued).

SN 85-291,486. SANTA MONICA CONVENTION & VISITORS BUREAU, SANTA MONICA, CA. FILED 4-11-2011.



OWNER OF U.S. REG. NOS. 2,214,325, 3,704,580 AND OTHERS.

THE MARK CONSISTS OF THE NAME "SANTAMONICA" ABOVE THE WORDS "CALIFORNIA'S MOST", WHICH ARE ABOVE THE WORDS "CELEBRATED BEACH CITY". ABOVE ALL THE WORDING IS A STYLIZED SILHOUETTE DESIGN INCLUDING, FROM LEFT TO RIGHT, PALM TREES, BUILDING, FERRIS WHEEL, PALM TREES, ARCHED ENTRYWAY, PALM TREES AND BUILDING.

SEC. 2(F) AS TO "SANTA MONICA".

FOR ASSOCIATION SERVICES, NAMELY, PROMOTING THE BUSINESS INTERESTS OF MEMBERS OF THE HOTEL, RESTAURANT, RECREATION, THEATER, MUSEUM AND RETAIL SHOP INDUSTRIES; PROMOTING PUBLIC AWARENESS OF COMMUNITY AND CIVIC EVENTS, CULTURE AND THE ARTS; PROVIDING BUSINESS INFORMATION REGARDING BUSINESS DEVELOPMENTS IN THE SANTA MONICA, CALIFORNIA AREA VIA A WORLD WIDE WEB WEBSITE; PUBLIC RELATIONS; PUBLICITY SERVICES, NAMELY, PROMOTING THE GOODS AND SERVICES OF OTHERS VIA DISTRIBUTION AND DISSEMINATION OF ADVERTISING MATERIALS; CONVENTION AND VISITORS BUREAU SERVICES, NAMELY, PROMOTING BUSINESS, TOURISM AND CONVENTIONS IN THE SANTA MONICA, CALIFORNIA AREA; PROVIDING AN ONLINE DIRECTORY INFORMATION SERVICE FEATURING LISTINGS FOR RESTAURANTS AND OTHER FOOD ESTABLISHMENTS, FARMERS' MARKETS, SCHOOLS AND COLLEGES, SHOPPING MALLS AND OTHER SHOPPING VENUES, AND TOUR COMPANIES; AND CHAMBER OF COMMERCE SERVICES, NAMELY, PROMOTING BUSINESS AND TOURISM IN THE SANTA MONICA AND WESTERN AREAS OF LOS ANGELES COUNTY, CALIFORNIA (U.S. CLS. 100, 101 AND 102).

FIRST USE 2-28-2011; IN COMMERCE 2-28-2011.

LEIGH CAROLINE CASE, EXAMINING ATTORNEY

SN 85-291,539. WHITE, DELIA, LINCOLNWOOD, IL. AND LINDWALL, LAURIE, LINCOLNWOOD, IL. AND ELLIOTT, BRIAN, LINCOLNWOOD, IL. FILED 4-11-2011.

The Fox and The Bear

THE MARK CONSISTS OF STANDARD CHARACTERS WITHOUT CLAIM TO ANY PARTICULAR FONT, STYLE, SIZE, OR COLOR.

FOR RETAIL STORE SERVICES FEATURING ARTS AND CRAFTS, AND GENTLY USED CLOTHES, BOOKS AND TOYS (U.S. CLS. 100, 101 AND 102).

KELLY BOULTON, EXAMINING ATTORNEY

CLASS 35—(Continued).

SN 85-291,562. REMI COLLECTIONS LLC, HONOLULU, HI. FILED 4-11-2011.



THE STIPPLING IS FOR SHADING PURPOSES ONLY.
THE MARK CONSISTS OF AN ONE EYE MONSTER COMING OUT OF A BOX HOLDING A PRICE TAG. NEXT TO THE MONSTER IS THE STYLIZED TEXT "BUNDLE MONSTER". THERE IS A SMALL HALO ABOVE THE LETTER "B". UNDERNEATH IS THE STYLIZED TEXT "MONSTER DEALS AT ANGELIC PRICES".

FOR ON-LINE RETAIL STORE SERVICES FEATURING ELECTRONICS, BEAUTY PRODUCTS, FASHION, AND VIDEO GAME ACCESSORIES (U.S. CLS. 100, 101 AND 102).

FIRST USE 6-30-2009; IN COMMERCE 6-30-2009.
ANNE E. GUSTASON, EXAMINING ATTORNEY

SN 85-291,588. KAISER FOUNDATION HEALTH PLAN, INC., OAKLAND, CA. FILED 4-11-2011.

BASIC

THE MARK CONSISTS OF STANDARD CHARACTERS WITHOUT CLAIM TO ANY PARTICULAR FONT, STYLE, SIZE, OR COLOR.

FOR PROVIDING A DATABASE OF PATIENT MEDICAL INFORMATION DESIGNED TO FACILITATE PATIENT-AUTHORIZED AND HIPAA-COMPLIANT SHARING OF SUCH INFORMATION AMONG DIFFERENT HEALTH CARE ORGANIZATIONS (U.S. CLS. 100, 101 AND 102).

HELENE LIWINSKI, EXAMINING ATTORNEY

SN 85-291,592. KAISER FOUNDATION HEALTH PLAN, INC., OAKLAND, CA. FILED 4-11-2011.

BASIC PLUS

THE MARK CONSISTS OF STANDARD CHARACTERS WITHOUT CLAIM TO ANY PARTICULAR FONT, STYLE, SIZE, OR COLOR.

FOR PROVIDING A DATABASE OF PATIENT MEDICAL INFORMATION DESIGNED TO FACILITATE PATIENT-AUTHORIZED AND HIPAA-COMPLIANT VERIFICATION OF PATIENT IDENTITIES AND SHARING OF SUCH INFORMATION AMONG DIFFERENT HEALTH CARE ORGANIZATIONS (U.S. CLS. 100, 101 AND 102).

HELENE LIWINSKI, EXAMINING ATTORNEY

CLASS 35—(Continued).

SN 85-291,668. DEFLOURED LLC, CHICAGO, IL. FILED 4-11-2011.

Defloured

THE MARK CONSISTS OF STANDARD CHARACTERS WITHOUT CLAIM TO ANY PARTICULAR FONT, STYLE, SIZE, OR COLOR.

FOR RETAIL BAKERY SHOPS (U.S. CLS. 100, 101 AND 102).

FIRST USE 9-22-2010; IN COMMERCE 12-12-2010.
GEORGE LORENZO, EXAMINING ATTORNEY

SN 85-291,790. PENTAD, INC., PRINCETON, NJ. FILED 4-11-2011.

3PE

THE MARK CONSISTS OF STANDARD CHARACTERS WITHOUT CLAIM TO ANY PARTICULAR FONT, STYLE, SIZE, OR COLOR.

FOR EMPLOYMENT AGENCY SERVICES, NAMELY, FILLING THE TEMPORARY AND PERMANENT STAFFING NEEDS OF BUSINESSES; EMPLOYMENT HIRING, RECRUITING, PLACEMENT, STAFFING AND CAREER NETWORKING SERVICES; EMPLOYMENT STAFFING CONSULTATION SERVICES; PERSONNEL PLACEMENT AND RECRUITMENT; PERSONNEL RECRUITMENT SERVICES AND EMPLOYMENT AGENCIES; PROFESSIONAL STAFFING AND RECRUITING SERVICES; PROVIDING AN EMPLOYER WITH CANDIDATES OR POTENTIAL EMPLOYEES TO FILL TEMPORARY, CONTRACT AND PERMANENT POSITIONS (U.S. CLS. 100, 101 AND 102).

FIRST USE 3-1-2011; IN COMMERCE 3-1-2011.
KARANENDRA S. CHHINA, EXAMINING ATTORNEY

SN 85-291,884. PIONEER MICROSYSTEMS, INC., PITTSBURGH, PA. FILED 4-11-2011.

Mag-Kits

THE MARK CONSISTS OF STANDARD CHARACTERS WITHOUT CLAIM TO ANY PARTICULAR FONT, STYLE, SIZE, OR COLOR.

FOR ON-LINE RETAIL STORE SERVICES FEATURING PROTOTYPING KITS CONSISTING OF CORES, BOBBINS, WIRE, TAPE AND TOOLS THAT ENABLE THE ASSEMBLY OF SWITCH MODE TRANSFORMERS AND COILS (U.S. CLS. 100, 101 AND 102).

FIRST USE 3-21-2011; IN COMMERCE 3-21-2011.
KAPIL BHANOT, EXAMINING ATTORNEY

CLASS 35—(Continued).

SN 85-292,019. RUTLEDGE, PAMELA, PALO ALTO, CA. AND BUCKNER, BONNIE, PALO ALTO, CA. FILED 4-11-2011.

A Think Lab

THE MARK CONSISTS OF STANDARD CHARACTERS WITHOUT CLAIM TO ANY PARTICULAR FONT, STYLE, SIZE, OR COLOR.

FOR BUSINESS MANAGEMENT CONSULTING WITH RELATION TO STRATEGY, MARKETING, SALES, OPERATION, PRODUCT DESIGN PARTICULARLY SPECIALIZING IN THE USE OF ANALYTIC AND STATISTIC MODELS FOR THE UNDERSTANDING AND PREDICTING OF CONSUMERS, BUSINESSES, AND MARKET TRENDS AND ACTIONS (U.S. CLS. 100, 101 AND 102).

FIRST USE 6-1-2010; IN COMMERCE 2-19-2011.
TOBY BULLOFF, EXAMINING ATTORNEY

SN 85-292,078. WILOPEN PRODUCTS, DEERFIELD BEACH, FL. FILED 4-11-2011.



THE MARK CONSISTS OF A HIGHLY STYLIZED BOOK OF FLIPPING PAGES.

FOR ADVERTISING AGENCY SPECIALIZING IN THE DESIGN AND EXECUTION OF WORD OF MOUTH, VIRAL, BUZZ AND EXPERIENTIAL MARKETING PROGRAMS; ADVERTISING AND MARKETING; ADVERTISING AND MARKETING CONSULTANCY; ADVERTISING AND MARKETING SERVICES, NAMELY, PROMOTING THE GOODS AND SERVICES OF OTHERS; ADVERTISING SERVICES, PUBLIC RELATIONS AND MARKETING SERVICES, NAMELY, PROMOTING AND MARKETING THE GOODS AND SERVICES OF OTHERS THROUGH ALL PUBLIC COMMUNICATION MEANS; ADVERTISING, MARKETING AND PROMOTION SERVICES; ADVICE IN THE FIELD OF BUSINESS MANAGEMENT AND MARKETING; ANALYSIS OF MARKET RESEARCH DATA AND STATISTICS; BRANDING SERVICES, NAMELY, CONSULTING, DEVELOPMENT, MANAGEMENT AND MARKETING OF BRANDS FOR BUSINESSES; BUSINESS MANAGEMENT AND ADVISORY SERVICES TO COMPANIES IN FRAGMENTED INDUSTRIES DESIRING TO CONSOLIDATE/ROLL UP USING A PARTNERSHIP STRUCTURE; BUSINESS MANAGEMENT ASSISTANCE TO INDUSTRIAL OR COMMERCIAL COMPANIES; BUSINESS MANAGEMENT CONSULTING WITH RELATION TO STRATEGY, MARKETING, PRODUCTION, PERSONNEL AND RETAIL SALE MATTERS; BUSINESS MANAGEMENT CONSULTING WITH RELATION TO STRATEGY, MARKETING, SALES, OPERATION, PRODUCT DESIGN PARTICULARLY

CLASS 35—(Continued).

SPECIALIZING IN THE USE OF ANALYTIC AND STATISTIC MODELS FOR THE UNDERSTANDING AND PREDICTING OF CONSUMERS, BUSINESSES, AND MARKET TRENDS AND ACTIONS; BUSINESS MARKETING AND DIRECT MAIL CONSULTING SERVICES; BUSINESS MARKETING CONSULTING SERVICES; BUSINESS MARKETING SERVICES; BUSINESS MONITORING AND CONSULTING SERVICES, NAMELY, TRACKING WEB SITES AND APPLICATIONS OF OTHERS TO PROVIDE STRATEGY, INSIGHT, MARKETING, SALES, OPERATION, PRODUCT DESIGN, PARTICULARLY SPECIALIZING IN THE USE OF ANALYTIC AND STATISTIC MODELS FOR THE UNDERSTANDING AND PREDICTING OF CONSUMERS, BUSINESSES, AND MARKET TRENDS AND ACTIONS; BUSINESS TO BUSINESS DIRECT MARKETING SERVICES; COLLECTION OF MARKET RESEARCH INFORMATION; CONSULTATION SERVICES, NAMELY, CREATIVE AND STRATEGIC CONSULTATION REGARDING DEVELOPMENT AND PRODUCTION OF MARKETING CAMPAIGNS FOR OTHERS; CONSULTING SERVICES IN THE FIELD OF INTERNET MARKETING; CONSUMER STRATEGY BUSINESS CONSULTING IN THE FIELDS OF MARKETING, SALES, OPERATION, AND PRODUCT DESIGN PARTICULARLY SPECIALIZING IN THE USE OF ANALYTIC MODELS FOR THE UNDERSTANDING AND PREDICTING OF CONSUMER, BUSINESS, AND RETAIL MARKET TRENDS AND ACTIONS; CREATION OF MARKETING TOOLS DESIGNED TO INCREASE A CLIENT COMPANY'S KNOWLEDGE OF CUSTOMER NEEDS, AND ITS COMPETITORS' PRODUCTS AND SERVICES, PRICING, ADVERTISING STRATEGY AND SALES STRATEGY; CREATIVE MARKETING DESIGN SERVICES; CUSTOM WRITING SERVICES COMPRISING PUBLIC RELATIONS AND MARKETING MATERIALS FOR THE AUDIO, VIDEO AND TECHNOLOGY INDUSTRIES; DEVELOPMENT OF MARKETING STRATEGIES AND CONCEPTS; DEVELOPMENT OF MARKETING STRATEGIES, CONCEPTS AND TACTICS, NAMELY, AUDIENCE DEVELOPMENT, BRAND AWARENESS, CUSTOMER RELATIONS, ONLINE COMMUNITY BUILDING AND DIGITAL WORD OF MOUTH COMMUNICATIONS; DEVELOPMENT OF MARKETING STRATEGIES, CONCEPTS AND TACTICS, NAMELY, AUDIENCE DEVELOPMENT, BRAND AWARENESS, ONLINE COMMUNITY BUILDING AND DIGITAL WORD OF MOUTH COMMUNICATIONS; DIRECT MARKETING; DIRECT MARKETING ADVERTISING FOR OTHERS; DIRECT MARKETING CONSULTING SERVICES; GENERAL BUSINESS MERCHANDISING SERVICES, NAMELY, MARKETING; INFORMATION OR ENQUIRIES ON BUSINESS AND MARKETING; INTERNATIONAL BUSINESS CONSULTING SERVICES RELATING TO MERCHANDISE TRADING, HUMAN RESOURCE INTERCHANGE, MANAGEMENT SUPPORT, MARKETING, ADVERTISING, PROMOTION, AND DOMESTIC AND INTERNATIONAL MARKET RESEARCH AND DEVELOPMENT; MARKET ANALYSIS; MARKET ANALYSIS AND RESEARCH SERVICES; MARKET ASSESSMENT SERVICES; MARKET MANIPULATION, RESEARCH AND ANALYSIS, WHETHER OR NOT VIA THE INTERNET; MARKET REPORTS AND STUDIES; MARKET RESEARCH; MARKET RESEARCH AND BUSINESS ANALYSES; MARKET RESEARCH AND MARKET INTELLIGENCE SERVICES; MARKET RESEARCH BY MEANS OF A COMPUTER DATABASE; MARKET RESEARCH CONSULTATION; MARKET RESEARCH SERVICES; MARKET RESEARCH STUDIES; MARKET SEGMENTATION CONSULTATION; MARKET STUDY AND ANALYSIS OF MARKET STUDIES; MARKETING ANALYSIS SERVICES; MARKETING AND BRANDING SERVICES, NAMELY, PROVIDING CUSTOMIZED COMMUNICATION PROGRAMS TO OBTAIN CONSUMER INSIGHTS AND DEVELOP BRANDING STRATEGIES; MARKETING CONSULTING; MARKETING PLAN DEVELOPMENT; MARKETING RESEARCH SERVICES; MARKETING SERVICES, NAMELY, CONSUMER MARKETING RESEARCH; MARKETING SERVICES, NAMELY, PROMOTING OR ADVERTISING THE GOODS AND SERVICES OF OTHERS; MARKETING, ADVERTISING, AND PROMOTING THE RETAIL GOODS AND SERVICES OF OTHERS TO WIRELESS ELECTRONIC DEVICES; MEDIA PLANNING, NAMELY, ADVISING THE CLIENT ON THE CORRECT TIMES AND STATIONS TO ADVERTISE BASED ON MEDIA ANALYSIS OF THE MARKET FOR THAT MEDIA; ON-

CLASS 35—(Continued).

LINE ADVERTISING AND MARKETING SERVICES; PROMOTING AND MARKETING THE GOODS AND SERVICES OF OTHERS BY DISTRIBUTING ADVERTISING MATERIAL, COUPONS AND DISCOUNT OFFERS VIA TEXT MESSAGES; PROMOTING THE GOODS AND SERVICES OF OTHERS BY MEANS OF WORD-OF-MOUTH AND NONTRADITIONAL MARKETING PROGRAMS; PROMOTING, ADVERTISING AND MARKETING OF THE BRANDS, PRODUCTS, SERVICES OR ONLINE WEBSITES OF INDIVIDUALS, BUSINESSES AND NONPROFIT ORGANIZATIONS; PROMOTING, ADVERTISING AND MARKETING OF THE ON-LINE WEB SITES OF OTHERS; PROMOTING, ADVERTISING AND MARKETING THE ON-LINE DATABASES AND ELECTRONIC PUBLICATIONS OF OTHERS; PROMOTION AND MARKETING SERVICES AND RELATED CONSULTING; PROMOTION, ADVERTISING AND MARKETING OF ON-LINE WEBSITES; PROMOTIONAL MARKETING SERVICES USING AUDIOVISUAL MEDIA; PROVIDING ADVERTISING, MARKETING AND PROMOTIONAL SERVICES, NAMELY, DEVELOPMENT OF ADVERTISING CAMPAIGNS FOR CABLE TELEVISION.; PROVIDING ADVERTISING, MARKETING AND PROMOTIONAL SERVICES, NAMELY, DEVELOPMENT OF ADVERTISING CAMPAIGNS PROVIDED THROUGH CABLE TELEVISION BROADCAST, WEB CASTS, RADIO BROADCASTS, NEWSPAPERS, MAGAZINES, ONLINE BANNERS, OUTDOOR BILLBOARDS, WILD POSTINGS, BUS AND SUBWAY ADS; PROVIDING BUSINESS MARKETING INFORMATION; PROVIDING INCENTIVE AWARD PROGRAMS FOR CUSTOMERS THROUGH ISSUANCE AND PROCESSING OF LOYALTY POINTS FOR ON-LINE PURCHASE OF COMPANY'S GOODS AND SERVICES; PROVIDING INFORMATION IN THE FIELD OF MARKETING AND ON-LINE MARKETING MEDIA VIA THE INTERNET; STATISTICAL EVALUATIONS OF MARKETING DATA (U.S. CLS. 100, 101 AND 102).

FIRST USE 4-15-2008; IN COMMERCE 4-22-2008.
WILLIAM ROSSMAN, EXAMINING ATTORNEY

SN 85-292,152. CLEAR CHANNEL OUTDOOR, INC., SAN ANTONIO, TX. FILED 4-11-2011.

OUT SMARTS

THE MARK CONSISTS OF STANDARD CHARACTERS WITHOUT CLAIM TO ANY PARTICULAR FONT, STYLE, SIZE, OR COLOR.

FOR OUT-OF-HOME ADVERTISING SERVICES, NAMELY, RENTAL OF ADVERTISING SPACE, AND PREPARING AND PLACING ADVERTISEMENTS FOR OTHERS (U.S. CLS. 100, 101 AND 102).

FIRST USE 9-30-2010; IN COMMERCE 9-30-2010.
WILLIAM BRECKENFELD, EXAMINING ATTORNEY

CLASS 35—(Continued).

SN 85-292,166. CLEAR CHANNEL OUTDOOR, INC., SAN ANTONIO, TX. FILED 4-11-2011.

OUT PERFORMS

THE MARK CONSISTS OF STANDARD CHARACTERS WITHOUT CLAIM TO ANY PARTICULAR FONT, STYLE, SIZE, OR COLOR.

FOR OUT-OF-HOME ADVERTISING SERVICES, NAMELY, RENTAL OF ADVERTISING SPACE, AND PREPARING AND PLACING ADVERTISEMENTS FOR OTHERS (U.S. CLS. 100, 101 AND 102).

FIRST USE 9-30-2010; IN COMMERCE 9-30-2010.
WILLIAM BRECKENFELD, EXAMINING ATTORNEY

SN 85-292,169. CLEAR CHANNEL OUTDOOR, INC., SAN ANTONIO, TX. FILED 4-11-2011.

OUT SELLS

THE MARK CONSISTS OF STANDARD CHARACTERS WITHOUT CLAIM TO ANY PARTICULAR FONT, STYLE, SIZE, OR COLOR.

FOR OUT-OF-HOME ADVERTISING SERVICES, NAMELY, RENTAL OF ADVERTISING SPACE, AND PREPARING AND PLACING ADVERTISEMENTS FOR OTHERS (U.S. CLS. 100, 101 AND 102).

WILLIAM BRECKENFELD, EXAMINING ATTORNEY

SN 85-292,174. CLEAR CHANNEL OUTDOOR, INC., SAN ANTONIO, TX. FILED 4-11-2011.

OUT SPOKEN

THE MARK CONSISTS OF STANDARD CHARACTERS WITHOUT CLAIM TO ANY PARTICULAR FONT, STYLE, SIZE, OR COLOR.

FOR OUT-OF-HOME ADVERTISING SERVICES, NAMELY, RENTAL OF ADVERTISING SPACE, AND PREPARING AND PLACING ADVERTISEMENTS FOR OTHERS (U.S. CLS. 100, 101 AND 102).

WILLIAM BRECKENFELD, EXAMINING ATTORNEY

CLASS 35—(Continued).

SN 85-292,273. IT'S ALL ABOUT THE VENUE, LLC, SAN RAFAEL, CA. FILED 4-11-2011.

It's All About The Venue

THE MARK CONSISTS OF STANDARD CHARACTERS WITHOUT CLAIM TO ANY PARTICULAR FONT, STYLE, SIZE, OR COLOR.

FOR PROVIDING A SEARCHABLE ONLINE ADVERTISING WEBSITE AND INFORMATIONAL GUIDE FEATURING THE GOODS AND SERVICES OF OTHER VENDORS VIA THE INTERNET IN THE FIELD OF WEDDINGS AND EVENTS (U.S. CLS. 100, 101 AND 102).

FIRST USE 5-12-2010; IN COMMERCE 3-4-2011.
ANNE MADDEN, EXAMINING ATTORNEY

CLASS 35—(Continued).

SN 85-292,510. AMERICAN HOME SHIELD CORPORATION, MEMPHIS, TN. FILED 4-12-2011.



THE MARK CONSISTS OF AN INTERLOCKING HOUSE AND SHIELD DESIGN.

FOR WARRANTY SERVICES, NAMELY, ARRANGING FOR REPAIRS AND REPLACEMENT OF MAJOR HOME SYSTEMS, APPLIANCES AND PARTS THEREOF PROVIDED BY OTHERS PURSUANT TO SERVICE AGREEMENTS; PROVIDING BUSINESS INFORMATION IN THE FIELD OF HOME WARRANTIES TO REAL ESTATE PROFESSIONALS, HOME BUYERS, HOME SELLERS, HOME INSPECTORS AND HOME REPAIR CONTRACTORS (U.S. CLS. 100, 101 AND 102).

GISELLE AGOSTO, EXAMINING ATTORNEY

SN 85-292,287. DIRACTION USA, INC., SUNNYVALE, CA. FILED 4-11-2011.

DIRACTION

THE MARK CONSISTS OF STANDARD CHARACTERS WITHOUT CLAIM TO ANY PARTICULAR FONT, STYLE, SIZE, OR COLOR.

FOR VALUE-ADDED RESELLER SERVICES, NAMELY, DISTRIBUTORSHIP SERVICES FEATURING COMPUTER SOFTWARE, HARDWARE, AND INFORMATION TECHNOLOGY PRODUCTS (U.S. CLS. 100, 101 AND 102).

FIRST USE 10-20-2003; IN COMMERCE 11-15-2003.
ELIZABETH KAJUBI, EXAMINING ATTORNEY

SN 85-292,615. UNIQUE BLADE LLC, LAKELAND, FL. FILED 4-12-2011.

**Our number and name is one
in the same**

SN 85-292,479. B FIT, LLC, GRAND HAVEN, MI. FILED 4-12-2011.



THE MARK CONSISTS OF THE WORD "BEACHFIT" WHEREIN THE "B" COMPRISES A RUNNING FIGURE.

FOR ON-LINE RETAIL STORE SERVICES FEATURING CLOTHING, FITNESS TOOLS AND DVDS (U.S. CLS. 100, 101 AND 102).

JORDAN BAKER, EXAMINING ATTORNEY

THE MARK CONSISTS OF STANDARD CHARACTERS WITHOUT CLAIM TO ANY PARTICULAR FONT, STYLE, SIZE, OR COLOR.

FOR ON-LINE RETAIL STORE SERVICES FEATURING A WIDE COLLECTION OF VARIOUS KNIVES AND KNIFE ACCESSORIES (U.S. CLS. 100, 101 AND 102).

AMY HELLA, EXAMINING ATTORNEY

CLASS 35—(Continued).

SN 85-292,713. EXTRA VIRGIN, AN OLIVE OVATION, LLC, CLAYTON, MO. FILED 4-12-2011.

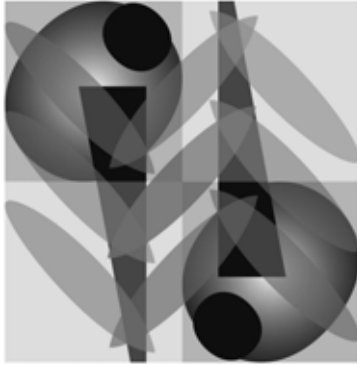

THE MARK CONSISTS OF A LARGE SQUARE CONTAINING FOUR SMALLER SQUARES, TWO STYLIZED OLIVES, AND TWO STYLIZED OLIVE BRANCHES.

FOR RETAIL STORE SERVICES AND ONLINE RETAIL STORE SERVICES FEATURING OLIVES, OLIVE OILS, VINEGARS, SPECIALTY FOODS, SPICES, SPREADS, SAUCES, DESSERTS, AND OLIVE-RELATED NOVELTY ITEMS AND HOUSEWARES (U.S. CLS. 100, 101 AND 102).

FIRST USE 10-0-2007; IN COMMERCE 10-0-2007.
BRENDAN REGAN, EXAMINING ATTORNEY

SN 85-292,720. RUTLEDGE, PAMELA, PALO ALTO, CA. AND BUCKNER, BONNIE, PALO ALTO, CA. FILED 4-12-2011.

StoryOpenings

THE MARK CONSISTS OF STANDARD CHARACTERS WITHOUT CLAIM TO ANY PARTICULAR FONT, STYLE, SIZE, OR COLOR.

FOR BUSINESS MANAGEMENT CONSULTING WITH RELATION TO STRATEGY, MARKETING, SALES, OPERATION, PRODUCT DESIGN PARTICULARLY SPECIALIZING IN THE USE OF ANALYTIC AND THEORETICAL MODELS FOR THE UNDERSTANDING AND PREDICTING OF CONSUMERS, BUSINESSES, AND MARKET TRENDS AND ACTIONS (U.S. CLS. 100, 101 AND 102).

TOBY BULLOFF, EXAMINING ATTORNEY

CLASS 35—(Continued).

SN 85-292,790. GRANT, JUSTIN, ESCONDIDO, CA. FILED 4-12-2011.

KEWLGAMEZ

THE MARK CONSISTS OF STANDARD CHARACTERS WITHOUT CLAIM TO ANY PARTICULAR FONT, STYLE, SIZE, OR COLOR.

FOR RETAIL STORE SERVICES AND ONLINE RETAIL STORE SERVICES FEATURING BOARD GAMES, VIDEO GAMES, CARD GAMES, INTERNET AND WEB GAMES, PUZZLES, GAMING ACCESSORIES SUCH AS POKER CHIPS AND POKER TABLES, ARCADE TYPE GAMES, SPORTING GAMES AND ACCESSORIES, HOBBY RELATED EQUIPMENT AND ACCESSORIES (U.S. CLS. 100, 101 AND 102).

ZACHARY BELLO, EXAMINING ATTORNEY

SN 85-292,909. GRENIER, ERIC, PARKER, CO. FILED 4-12-2011.

COMCENTRIC

THE MARK CONSISTS OF STANDARD CHARACTERS WITHOUT CLAIM TO ANY PARTICULAR FONT, STYLE, SIZE, OR COLOR.

FOR INFORMATION TECHNOLOGY CONSULTING, STAFFING AND EXECUTIVE RECRUITMENT (U.S. CLS. 100, 101 AND 102).

FIRST USE 10-22-2003; IN COMMERCE 10-22-2003.
JILL C. ALT, EXAMINING ATTORNEY

SN 85-293,000. CAESARS LICENSE COMPANY, LLC, LAS VEGAS, NV. FILED 4-12-2011.

Total Rewards Marketplace

THE MARK CONSISTS OF STANDARD CHARACTERS WITHOUT CLAIM TO ANY PARTICULAR FONT, STYLE, SIZE, OR COLOR.

OWNER OF U.S. REG. NOS. 2,830,063, 3,858,245 AND OTHERS.

NO CLAIM IS MADE TO THE EXCLUSIVE RIGHT TO USE "REWARDS MARKETPLACE", APART FROM THE MARK AS SHOWN.

FOR PROMOTING THE GOODS AND SERVICES OF OTHERS BY MEANS OF OPERATING AN ON-LINE SHOPPING MALL WITH LINKS TO THE RETAIL WEB SITES OF OTHERS; PROVIDING INCENTIVE AWARD PROGRAM FOR CUSTOMERS THROUGH ISSUANCE AND PROCESSING OF LOYALTY POINTS FOR ON-LINE PURCHASE OF RETAIL PRODUCTS AND SERVICES OF OTHERS (U.S. CLS. 100, 101 AND 102).

FIRST USE 5-9-2011; IN COMMERCE 5-9-2011.
AMY KERTGATE, EXAMINING ATTORNEY

CLASS 35—(Continued).

SN 85-293,020. WESLEY CLEGG, INC, REHOBOTH, MA.
FILED 4-12-2011.

THE CORNBEETLE

THE MARK CONSISTS OF STANDARD CHARACTERS WITHOUT CLAIM TO ANY PARTICULAR FONT, STYLE, SIZE, OR COLOR.

FOR RETAIL STORE SERVICES FEATURING CORN AND OTHER FRESH VEGETABLES AND PRODUCE (U.S. CLS. 100, 101 AND 102).

CURTIS FRENCH, EXAMINING ATTORNEY

SN 85-293,046. UNITED STATES GYPSUM COMPANY,
CHICAGO, IL. FILED 4-12-2011.

**MARKET DRIVEN, TECHNOLOGY
FUELED**

THE MARK CONSISTS OF STANDARD CHARACTERS WITHOUT CLAIM TO ANY PARTICULAR FONT, STYLE, SIZE, OR COLOR.

FOR PROVIDING CONSUMER INFORMATION IN THE FIELD OF CONSTRUCTION, NAMELY, GYPSUM AND CONCRETE PRODUCTS (U.S. CLS. 100, 101 AND 102).

RONALD MCMORROW, EXAMINING ATTORNEY

SN 85-293,182. CERTIFIED FOLDER DISPLAY SERVICE,
INC., VISTA, CA. FILED 4-12-2011.



OWNER OF U.S. REG. NOS. 1,688,066, 1,703,620 AND 1,776,726.

THE MARK CONSISTS OF THE STYLIZED WORD "VISITORTIPS" WHICH IS PARTIALLY UNDERLINED, FOLLOWED BY FOUR INTERSECTING SQUARES, FOLLOWED BY THE WORD "COM".

FOR DISSEMINATION OF ADVERTISING FOR OTHERS VIA PUBLIC AND PRIVATE WIRELESS NETWORKS FOR DISPLAY ON MOBILE DEVICES; DISSEMINATION OF ADVERTISING FOR OTHERS VIA THE INTERNET; PROVIDING A SEARCHABLE ONLINE ADVERTISING WEBSITE AND INFORMATIONAL GUIDE FEATURING THE GOODS AND SERVICES OF OTHER VENDORS VIA THE INTERNET IN THE FIELD OF TRAVEL INFORMATION (U.S. CLS. 100, 101 AND 102).

FIRST USE 4-1-2010; IN COMMERCE 3-1-2011.

JAY FLOWERS, EXAMINING ATTORNEY

CLASS 35—(Continued).

SN 85-293,184. SANDERS/WINGO ADVERTISING, INC., EL PASO, TX. FILED 4-12-2011.

Like League

THE MARK CONSISTS OF STANDARD CHARACTERS WITHOUT CLAIM TO ANY PARTICULAR FONT, STYLE, SIZE, OR COLOR.

FOR ADVERTISING AND MARKETING SERVICES PROVIDED BY MEANS OF INDIRECT METHODS OF MARKETING COMMUNICATIONS, NAMELY, SOCIAL MEDIA, SEARCH ENGINE MARKETING, INQUIRY MARKETING, INTERNET MARKETING, MOBILE MARKETING, BLOGGING AND OTHER FORMS OF PASSIVE, SHARABLE OR VIRAL COMMUNICATIONS CHANNELS (U.S. CLS. 100, 101 AND 102).

FIRST USE 1-19-2011; IN COMMERCE 1-19-2011.

JAY FLOWERS, EXAMINING ATTORNEY

SN 85-293,208. ZAEGEL, ROBERT L, NASHVILLE, TN.
FILED 4-12-2011.

Contract Confidential

THE MARK CONSISTS OF STANDARD CHARACTERS WITHOUT CLAIM TO ANY PARTICULAR FONT, STYLE, SIZE, OR COLOR.

FOR BUSINESS ADVISORY SERVICES, CONSULTANCY AND INFORMATION; BUSINESS CONSULTATION; BUSINESS CONSULTATION SERVICES IN THE FIELDS OF SUPPLY CHAIN ANALYSIS, REGULATION COMPLIANCE AND COUNTERFEIT DETECTION (U.S. CLS. 100, 101 AND 102).

FIRST USE 12-10-2010; IN COMMERCE 12-10-2010.

CHRIS WELLS, EXAMINING ATTORNEY

CLASS 35—(Continued).

SN 85-293,240. NUDGERX, INC., REDMOND, WA. FILED 4-12-2011.

NudgeRx

THE MARK CONSISTS OF STANDARD CHARACTERS WITHOUT CLAIM TO ANY PARTICULAR FONT, STYLE, SIZE, OR COLOR.

FOR BUSINESS AND MANAGEMENT CONSULTING FOR HEALTHCARE PROVIDERS AND RELATED BUSINESSES; BUSINESS CONSULTING SERVICES RELATING TO THE INTEGRATION OF THE AREAS OF BUSINESS PROCESS TECHNOLOGY, ORGANIZATIONAL LEARNING, CHANGE MANAGEMENT, AND OPERATIONAL SUSTAINABILITY; BUSINESS SERVICES PROVIDED TO THE HEALTHCARE INDUSTRY, NAMELY, THE COLLECTION, REPORTING, AND ANALYSIS OF HEALTHCARE QUALITY DATA FOR BUSINESS PURPOSES; CONSULTING IN THE FIELDS OF HEALTHCARE OPERATIONS MANAGEMENT AND HOSPITAL OPERATIONS MANAGEMENT; ELECTRONIC DATA COLLECTION AND DATA SUBMISSION SERVICES FOR BUSINESS PURPOSES IN THE FIELDS OF MEDICINE AND HEALTHCARE (U.S. CLS. 100, 101 AND 102).

FIRST USE 6-1-2009; IN COMMERCE 6-1-2009.
JOHN WILKE, EXAMINING ATTORNEY

CLASS 35—(Continued).

SN 85-293,283. ORQUEST INVERSIONES, S.A. DE C.V., NUEVO LEON, MEXICO, FILED 4-12-2011.

ORQUEST

THE MARK CONSISTS OF STANDARD CHARACTERS WITHOUT CLAIM TO ANY PARTICULAR FONT, STYLE, SIZE, OR COLOR.

FOR BUSINESS MANAGEMENT; BUSINESS OPERATION, BUSINESS ADMINISTRATION AND OFFICE FUNCTIONS; OFFICE ADMINISTRATION SERVICES (U.S. CLS. 100, 101 AND 102).

DAVID COLLIER, EXAMINING ATTORNEY

SN 85-293,419. KANE, HILL, AKA HILLARY KANE / RAISING KANE, TORRANCE, CA. FILED 4-12-2011.

BECAUSE IDEAS NEED LEGS

THE MARK CONSISTS OF STANDARD CHARACTERS WITHOUT CLAIM TO ANY PARTICULAR FONT, STYLE, SIZE, OR COLOR.

FOR ADVERTISING AND BUSINESS MANAGEMENT CONSULTANCY; ADVERTISING AND MARKETING SERVICES, NAMELY, PROMOTING THE GOODS AND SERVICES OF OTHERS; ADVICE IN THE FIELD OF BUSINESS MANAGEMENT AND MARKETING; ARRANGING AND CONDUCTING MARKETING PROMOTIONAL EVENTS FOR OTHERS; ASSISTANCE, ADVISORY SERVICES AND CONSULTANCY WITH REGARD TO BUSINESS PLANNING, BUSINESS ANALYSIS, BUSINESS MANAGEMENT, BUSINESS ORGANIZATION, MARKETING AND CUSTOMER ANALYSIS; BRAND IMAGERY CONSULTING SERVICES; BRANDING SERVICES, NAMELY, CONSULTING, DEVELOPMENT, MANAGEMENT AND MARKETING OF BRANDS FOR BUSINESSES; BUSINESS CONSULTATION AND MANAGEMENT REGARDING MARKETING ACTIVITIES AND LAUNCHING OF NEW PRODUCTS; BUSINESS CONSULTATION SERVICES; BUSINESS MEETING PLANNING; CONSULTANCY SERVICES REGARDING BUSINESS STRATEGIES; DEVELOPMENT OF MARKETING STRATEGIES, CONCEPTS AND TACTICS, NAMELY, AUDIENCE DEVELOPMENT, BRAND AWARENESS, CUSTOMER RELATIONS, ONLINE COMMUNITY BUILDING AND DIGITAL WORD OF MOUTH COMMUNICATIONS; MARKETING AND BRANDING SERVICES, NAMELY, PERFORMING CONSUMER INSIGHT AND BRAND STRATEGY OF COMPANY LOGOS; MARKETING AND BRANDING SERVICES, NAMELY, PROVIDING CUSTOMIZED COMMUNICATION PROGRAMS TO OBTAIN CONSUMER INSIGHTS AND DEVELOP BRANDING STRATEGIES (U.S. CLS. 100, 101 AND 102).

DOMINIC FATHY, EXAMINING ATTORNEY

SN 85-293,263. GRUPO NACIONAL DE CHOCOLATES S.A., MEDELLIN, COLOMBIA, FILED 4-12-2011.

NUTRESA

THE MARK CONSISTS OF STANDARD CHARACTERS WITHOUT CLAIM TO ANY PARTICULAR FONT, STYLE, SIZE, OR COLOR.

THE WORDING NUTRESA HAS NO MEANING IN A FOREIGN LANGUAGE.

FOR BUSINESS ADMINISTRATION AND MANAGEMENT; BUSINESS ADMINISTRATION AND OFFICE WORK; BUSINESS ADMINISTRATION ASSISTANCE; BUSINESS ADMINISTRATION CONSULTANCY; OFFICE ADMINISTRATION SERVICES (U.S. CLS. 100, 101 AND 102).

DAVID COLLIER, EXAMINING ATTORNEY

CLASS 35—(Continued).

SN 85-293,448. PARTICIPACTION CONSULTING, INC., ALEXANDRIA, VA. FILED 4-13-2011.

From Power Point to Powerful

THE MARK CONSISTS OF STANDARD CHARACTERS WITHOUT CLAIM TO ANY PARTICULAR FONT, STYLE, SIZE, OR COLOR.

FOR BUSINESS CONSULTATION SERVICES; BUSINESS MANAGEMENT CONSULTANCY SERVICES; CONSULTING SERVICES IN THE FIELD OF HUMAN RESOURCES DEVELOPMENT, NAMELY, FOR THE PROMOTION OF EMPLOYEE RETENTION, CAREER GROWTH, AND INCREASED PRODUCTIVITY FOR EMPLOYEES AND EMPLOYERS; CONSULTING SERVICES IN THE FIELD OF HUMAN RESOURCES DEVELOPMENT, NAMELY, UTILIZING TECHNOLOGY FOR THE PROMOTION OF EMPLOYEE RETENTION, CAREER GROWTH AND INCREASED PRODUCTIVITY FOR EMPLOYEES AND EMPLOYERS; HUMAN RESOURCES SERVICES IN THE FIELD OF EDUCATION, NAMELY, OFFERING OF ASSESSMENTS AND SURVEYS IN THE FIELD OF EDUCATOR TRAINING AND PERFORMANCE FOR THE PURPOSE OF TEACHER PLACEMENT BASED ON SUCCESS IN AN ACADEMIC PROGRAM (U.S. CLS. 100, 101 AND 102).

FIRST USE 6-24-2006; IN COMMERCE 6-24-2006.
MARGERY A. TIERNEY, EXAMINING ATTORNEY

SN 85-293,519. CITYDAPS, INC., INDIAN HARBOUR BEACH, FL. FILED 4-12-2011.

CityDAPS

THE MARK CONSISTS OF STANDARD CHARACTERS WITHOUT CLAIM TO ANY PARTICULAR FONT, STYLE, SIZE, OR COLOR.

FOR AD SERVING, NAMELY, PLACING ADVERTISEMENTS ON WEBSITES FOR OTHERS USING SPECIALIZED COMPUTER SOFTWARE (U.S. CLS. 100, 101 AND 102).

MICHAEL SOUDERS, EXAMINING ATTORNEY

CLASS 35—(Continued).

SN 85-293,672. OCEAN LINK MANAGEMENT LTD., BELIZE CITY, BELIZE, FILED 4-13-2011.

FEEDBOX

THE MARK CONSISTS OF STANDARD CHARACTERS WITHOUT CLAIM TO ANY PARTICULAR FONT, STYLE, SIZE, OR COLOR.

FOR AD SERVING, NAMELY, PLACING ADVERTISEMENTS ON WEBSITES FOR OTHERS USING SPECIALIZED COMPUTER SOFTWARE; ADVERTISEMENT FOR OTHERS ON THE INTERNET; ADVERTISING AND ADVERTISEMENT SERVICES; ADVERTISING AND COMMERCIAL INFORMATION SERVICES, VIA THE INTERNET; ADVERTISING AND DIRECTORY SERVICES, NAMELY, PROMOTING THE SERVICES OF OTHERS BY PROVIDING A WEB PAGE FEATURING LINKS TO THE WEBSITES OF OTHERS; ADVERTISING AND MARKETING; ADVERTISING AND MARKETING SERVICES, NAMELY, PROMOTING THE GOODS AND SERVICES OF OTHERS; ADVERTISING AND PROMOTIONAL SERVICES; ADVERTISING ON THE INTERNET FOR OTHERS; ADVERTISING VIA ELECTRONIC MEDIA AND SPECIFICALLY THE INTERNET; ADVERTISING, INCLUDING ON-LINE ADVERTISING ON A COMPUTER NETWORK; ADVERTISING, INCLUDING PROMOTION RELATING TO THE SALE OF ARTICLES AND SERVICES FOR THIRD PARTIES BY THE TRANSMISSION OF ADVERTISING MATERIAL AND THE DISSEMINATION OF ADVERTISING MESSAGES ON COMPUTER NETWORKS; ADVERTISING, MARKETING AND PROMOTION SERVICES; ADVERTISING, PROMOTION, AND MARKETING SERVICES IN THE NATURE OF PROVIDING A SEARCHABLE ON-LINE ADVERTISING WEBSITE FOR THE GOODS AND SERVICES OF OTHERS; BANNER ADVERTISING; DISPLAYING ADVERTISEMENTS FOR OTHERS; DISSEMINATION OF ADVERTISEMENTS; DISSEMINATION OF ADVERTISING FOR OTHERS VIA AN ON-LINE COMMUNICATIONS NETWORK ON THE INTERNET; DISSEMINATION OF ADVERTISING FOR OTHERS VIA THE INTERNET; PROMOTION, ADVERTISING AND MARKETING OF ON-LINE WEBSITES; PROVIDING A SEARCHABLE ON-LINE ADVERTISING WEBSITE AND GUIDE FEATURING THE GOODS AND SERVICES OF OTHER VENDORS VIA THE INTERNET; PROVIDING A SEARCHABLE ONLINE ADVERTISING GUIDE FEATURING THE GOODS AND SERVICES OF ONLINE VENDORS; PROVIDING A SEARCHABLE ON-LINE ADVERTISING GUIDE FEATURING THE GOODS AND SERVICES OF OTHER ON-LINE VENDORS ON THE INTERNET; PROVIDING A SEARCHABLE WEBSITE FEATURING THE GOODS AND SERVICES OF OTHER VENDORS; PROVIDING A WEB SITE WHICH FEATURES ADVERTISEMENTS FOR THE GOODS AND SERVICES OF OTHERS ON A GLOBAL COMPUTER NETWORK; PROVIDING ADVERTISING AND ADVERTISEMENT SERVICES; PROVIDING AN ON-LINE COMMERCIAL INFORMATION DIRECTORY ON THE INTERNET; PROVIDING CONSUMER PRODUCT INFORMATION VIA THE INTERNET; PROVIDING ON-LINE DIRECTORY INFORMATION SERVICES ALSO FEATURING HYPERLINKS TO OTHER WEB SITES; PROVIDING SPACE AT A WEB SITE FOR THE ADVERTISEMENT OF THE GOODS AND SERVICES OF OTHERS; PROVIDING STATISTICAL INFORMATION; PROVISION OF SPACE ON WEBSITES FOR ADVERTISING GOODS AND SERVICES (U.S. CLS. 100, 101 AND 102).

FIRST USE 1-21-2011; IN COMMERCE 1-21-2011.
IRA J. GOODSaid, EXAMINING ATTORNEY

CLASS 35—(Continued).

SN 85-293,783. OWN LLC, LOS ANGELES, CA. FILED 4-13-2011.

OWNERS

THE MARK CONSISTS OF STANDARD CHARACTERS WITHOUT CLAIM TO ANY PARTICULAR FONT, STYLE, SIZE, OR COLOR.

FOR PROVIDING CONSUMER INFORMATION SERVICES IN THE FIELD OF GENERAL HUMAN INTEREST (U.S. CLS. 100, 101 AND 102).

CHRIS WELLS, EXAMINING ATTORNEY

SN 85-293,977. RECON STRATEGY LLC, CAMBRIDGE, MA. FILED 4-13-2011.

RECON STRATEGY

THE MARK CONSISTS OF STANDARD CHARACTERS WITHOUT CLAIM TO ANY PARTICULAR FONT, STYLE, SIZE, OR COLOR.

NO CLAIM IS MADE TO THE EXCLUSIVE RIGHT TO USE "STRATEGY", APART FROM THE MARK AS SHOWN.

FOR CONSULTANCY AND ADVISORY SERVICES IN THE FIELD OF BUSINESS STRATEGY (U.S. CLS. 100, 101 AND 102).

FIRST USE 7-13-2010; IN COMMERCE 7-13-2010.

GINA HAYES, EXAMINING ATTORNEY

SN 85-294,105. TECH MOBILE LLC, MIAMI, FL. FILED 4-13-2011.

NEXTOUCH

THE MARK CONSISTS OF STANDARD CHARACTERS WITHOUT CLAIM TO ANY PARTICULAR FONT, STYLE, SIZE, OR COLOR.

FOR ON-LINE RETAIL STORE SERVICES FEATURING COMPUTER ELECTRONICS INCLUDING PORTABLE COMPUTER TABLETS, PERIPHERALS AND RELATED ACCESSORIES; RETAIL STORE SERVICES FEATURING COMPUTER ELECTRONICS INCLUDING PORTABLE COMPUTER TABLETS, PERIPHERALS AND RELATED ACCESSORIES (U.S. CLS. 100, 101 AND 102).

SETH A. RAPPAPORT, EXAMINING ATTORNEY

CLASS 35—(Continued).

SN 85-294,122. THE SEVENEX GROUP, LLC, DUBLIN, OH. FILED 4-13-2011.

SEVENEX

THE MARK CONSISTS OF STANDARD CHARACTERS WITHOUT CLAIM TO ANY PARTICULAR FONT, STYLE, SIZE, OR COLOR.

FOR BUSINESS OPERATIONS CONSULTING SERVICES FOR HOSPITALS AND NURSING FACILITIES AND ASSISTED LIVING CENTERS (U.S. CLS. 100, 101 AND 102).

NAKWAMA ANKRAH, EXAMINING ATTORNEY

SN 85-294,180. MARCO STORE, LLC, DBA MACROBABY, ORLANDO, FL. FILED 4-13-2011.

MacroBaby

THE MARK CONSISTS OF STANDARD CHARACTERS WITHOUT CLAIM TO ANY PARTICULAR FONT, STYLE, SIZE, OR COLOR.

FOR ON-LINE RETAIL STORE SERVICES FEATURING BABY AND CHILDREN ITEMS RANGING FROM DIAPERS TO STROLLERS, CHILDREN CLOTHING, CHILD SAFETY DEVICES, BOTTLES TOYS AND GIFTS; RETAIL SHOPS FEATURING BABY AND CHILDREN ITEMS RANGING FROM DIAPERS TO STROLLERS, CHILDREN CLOTHING, CHILD SAFETY DEVICES, BOTTLES TOYS AND GIFTS (U.S. CLS. 100, 101 AND 102).

FIRST USE 4-13-2002; IN COMMERCE 4-13-2002.

DOMINICK J. SALEMI, EXAMINING ATTORNEY

CLASS 35—(Continued).

SN 85-294,383. IMURGENT, LLC, CLARKSTON, WA. FILED 4-13-2011.

LOYUL

THE MARK CONSISTS OF STANDARD CHARACTERS WITHOUT CLAIM TO ANY PARTICULAR FONT, STYLE, SIZE, OR COLOR.

FOR ADMINISTRATION OF A CONSUMER LOYALTY PROGRAM TO PROMOTE RESTAURANT SERVICES AND RETAIL SERVICES OF OTHERS; CUSTOMER LOYALTY SERVICES AND CUSTOMER CLUB SERVICES, FOR COMMERCIAL, PROMOTIONAL AND/OR ADVERTISING PURPOSES; PROVIDING INCENTIVE AWARD PROGRAMS FOR CUSTOMERS THROUGH ISSUANCE AND PROCESSING OF LOYALTY POINTS FOR ON-LINE PURCHASE OF COMPANY'S GOODS AND SERVICES; PROVIDING INCENTIVE AWARD PROGRAMS FOR CUSTOMERS THROUGH THE ISSUANCE AND PROCESSING OF LOYALTY COUPONS FOR FREQUENT USE OF PARTICIPATING BUSINESSES (U.S. CLS. 100, 101 AND 102).

FIRST USE 4-1-2011; IN COMMERCE 4-1-2011.

JULIE GUTTADAURO, EXAMINING ATTORNEY

CLASS 35—(Continued).

SN 85-294,445. CLOUD 2 HOLDINGS, LODI, CA. FILED 4-13-2011.

Bettervite

THE MARK CONSISTS OF STANDARD CHARACTERS WITHOUT CLAIM TO ANY PARTICULAR FONT, STYLE, SIZE, OR COLOR.

FOR ADMINISTRATION OF A PROGRAM FOR ENABLING PARTICIPANTS TO OBTAIN DISCOUNTS ON PRODUCTS AND SERVICES; ADVERTISING, INCLUDING PROMOTION RELATING TO THE SALE OF ARTICLES AND SERVICES FOR THIRD PARTIES BY THE TRANSMISSION OF ADVERTISING MATERIAL AND THE DISSEMINATION OF ADVERTISING MESSAGES ON COMPUTER NETWORKS; BUSINESS NETWORKING; DISSEMINATION OF ADVERTISING MATTER; ELECTRONIC COMMERCE SERVICES, NAMELY, PROVIDING INFORMATION ABOUT PRODUCTS VIA TELECOMMUNICATION NETWORKS FOR ADVERTISING AND SALES PURPOSES; GENERAL BUSINESS NETWORKING REFERRAL SERVICES, NAMELY, PROMOTING THE GOODS AND SERVICES OF OTHERS BY PASSING BUSINESS LEADS AND REFERRALS AMONG GROUP MEMBERS; ONLINE ADVERTISING VIA A COMPUTER COMMUNICATIONS NETWORK; PREPARING AND PLACING OF ADVERTISEMENTS; PROMOTING THE GOODS AND SERVICES OF OTHERS BY PROVIDING A COMMUNITY-DRIVEN WEB SITE FEATURING USER-SUBMITTED CONTENT IN THE NATURE OF COUPONS, REBATES, PRICE-COMPARISON INFORMATION, PRODUCT REVIEWS, LINKS TO THE RETAIL WEB SITES OF OTHERS, AND DISCOUNT INFORMATION; PROMOTING THE GOODS AND SERVICES OF OTHERS BY PROVIDING A WEBSITE FEATURING COUPONS, REBATES, PRICE-COMPARISON INFORMATION, PRODUCT REVIEWS, LINKS TO THE RETAIL WEBSITES OF OTHERS, AND DISCOUNT INFORMATION; PROMOTING THE GOODS AND SERVICES OF OTHERS VIA A GLOBAL COMPUTER NETWORK; PROMOTING THE GOODS OF OTHERS, NAMELY, PROVIDING INFORMATION REGARDING DISCOUNTS, COUPONS, REBATES, VOUCHERS AND SPECIAL OFFERS FOR THE GOODS OF OTHERS; PROVIDING A SEARCHABLE ON-LINE ADVERTISING WEBSITE AND GUIDE FEATURING THE GOODS AND SERVICES OF OTHER VENDORS VIA THE INTERNET; PROVIDING AN ON-LINE COMPUTER DATABASE IN THE FIELD OF LOCATING PRODUCTS, DESCRIBING PRODUCTS, RATING PRODUCTS, PRICING PRODUCTS AND COMPARING PRICES OF PRODUCTS; PROVIDING AN ON-LINE DIRECTORY INFORMATION SERVICE FEATURING INFORMATION REGARDING BARGAINS, DISCOUNTS, REBATES, COUPONS, SALE ITEMS AND GOODS AND SERVICES OF OTHERS; PROVIDING CONSUMER INFORMATION SERVICES AND MAKING REFERRALS IN THE FIELD OF ENTERTAINMENT SERVICES FOR PRODUCTS, SERVICES, EVENTS, ACTIVITIES, FACILITIES AND LOCATIONS; PROVIDING INFORMATION ABOUT COMMERCIAL BUSINESS AND COMMERCIAL INFORMATION VIA THE GLOBAL COMPUTER NETWORK (U.S. CLS. 100, 101 AND 102).

JOHN WILKE, EXAMINING ATTORNEY

SN 85-294,406. BRYLLIANT.COM, SAN DIEGO, CA. FILED 4-13-2011.

Brylliant

THE MARK CONSISTS OF STANDARD CHARACTERS WITHOUT CLAIM TO ANY PARTICULAR FONT, STYLE, SIZE, OR COLOR.

FOR AUTOMOBILE DEALERSHIPS (U.S. CLS. 100, 101 AND 102).

FIRST USE 1-2-2002; IN COMMERCE 1-2-2002.

THEODORE MCBRIDE, EXAMINING ATTORNEY

CLASS 35—(Continued).

SN 85-294,511. YEXT, INC., NEW YORK, NY. FILED 4-13-2011.

POWERLISTINGS

THE MARK CONSISTS OF STANDARD CHARACTERS WITHOUT CLAIM TO ANY PARTICULAR FONT, STYLE, SIZE, OR COLOR.

FOR PROVIDING BUSINESS INFORMATION, NAMELY, PROVIDING PHONE NUMBERS, MAILING ADDRESSES, ELECTRONIC MAIL ADDRESSES AND WEBSITE LINKS FOR A WIDE VARIETY OF LOCAL BUSINESSES AND ORGANIZATIONS VIA THE INTERNET AND MOBILE COMMUNICATION DEVICES; ADVERTISING AND COMMERCIAL INFORMATION SERVICES, VIA THE INTERNET AND MOBILE COMMUNICATION DEVICES; DISSEMINATION OF ADVERTISING, SPECIAL OFFERS AND DEALS FOR OTHERS VIA THE INTERNET AND MOBILE COMMUNICATIONS DEVICES; PROMOTING THE GOODS, SERVICES AND BRANDS OF BUSINESSES TO DRIVE CONSUMER INTEREST, ENGAGEMENT, ACTION AND TO GENERATE SALES TRAFFIC BY FEATURING HYPERLINKS TO OTHER BUSINESS WEBSITES (U.S. CLS. 100, 101 AND 102).

FIRST USE 4-18-2011; IN COMMERCE 4-18-2011.
MARK RADEMACHER, EXAMINING ATTORNEY

CLASS 35—(Continued).

SN 85-294,554. EXTOLLE, INC., SAN FRANCISCO, CA. FILED 4-13-2011.

LIKESAVER

THE MARK CONSISTS OF STANDARD CHARACTERS WITHOUT CLAIM TO ANY PARTICULAR FONT, STYLE, SIZE, OR COLOR.

FOR PROMOTING THE GOODS AND SERVICES OF OTHERS THROUGH THIRD PARTY SOCIAL MEDIA SITES AND THROUGH A WEBSITE FEATURING DISCOUNT PROMOTIONS, COUPONS, COUPON CODES, REBATES, PRODUCT AND SERVICE PRICING INFORMATION, CUSTOMER AND PROFESSIONAL REVIEW INFORMATION, AND ACCESS THROUGH HYPERLINKS TO THIRD PARTY WEBSITES SELLING GOODS AND SERVICES AT RETAIL (U.S. CLS. 100, 101 AND 102).

JULIE WATSON, EXAMINING ATTORNEY

SN 85-294,632. SPACEBOUND, INC., LAGRANGE, OH. FILED 4-13-2011.

NOTHINGBUTSAVINGS

SN 85-294,518. XERIQ CREATIVE SOLUTIONS, LLC, PHOENIX, AZ. FILED 4-13-2011.

XERIQ

THE MARK CONSISTS OF STANDARD CHARACTERS WITHOUT CLAIM TO ANY PARTICULAR FONT, STYLE, SIZE, OR COLOR.

FOR BRANDING SERVICES, NAMELY, CONSULTING, DEVELOPMENT, MANAGEMENT AND MARKETING OF BRANDS FOR BUSINESSES (U.S. CLS. 100, 101 AND 102).

FIRST USE 3-27-2006; IN COMMERCE 3-27-2006.
MARK RADEMACHER, EXAMINING ATTORNEY

THE MARK CONSISTS OF STANDARD CHARACTERS WITHOUT CLAIM TO ANY PARTICULAR FONT, STYLE, SIZE, OR COLOR.

OWNER OF U.S. REG. NOS. 2,530,940 AND 2,545,398.
FOR COMPUTERIZED ON-LINE ORDERING FEATURING GENERAL MERCHANDISE AND GENERAL CONSUMER GOODS; ON-LINE RETAIL STORE SERVICES FEATURING A WIDE VARIETY OF CONSUMER GOODS OF OTHERS; PROMOTING THE GOODS AND SERVICES OF OTHERS THROUGH ON-LINE ORDERING AND CATALOGING OF THOSE GOODS AND SERVICES (U.S. CLS. 100, 101 AND 102).

MICHAEL TANNER, EXAMINING ATTORNEY

CLASS 35—(Continued).

SN 85-294,715. MATEER, SCOTT, MASSAPEQUA, NY. FILED 4-13-2011.

Gottatext

THE MARK CONSISTS OF STANDARD CHARACTERS WITHOUT CLAIM TO ANY PARTICULAR FONT, STYLE, SIZE, OR COLOR.

FOR ADVERTISING TEXT PUBLICATION SERVICES; ADVERTISING, INCLUDING PROMOTION RELATING TO THE SALE OF ARTICLES AND SERVICES FOR THIRD PARTIES BY THE TRANSMISSION OF ADVERTISING MATERIAL AND THE DISSEMINATION OF ADVERTISING MESSAGES ON COMPUTER NETWORKS; EMPLOYMENT RECRUITING AND STAFFING SERVICES PROVIDED VIA TEXT MESSAGING; ISSUING AND UPDATING OF ADVERTISING TEXTS; PROMOTING AND MARKETING THE GOODS AND SERVICES OF OTHERS BY DISTRIBUTING ADVERTISING MATERIAL, COUPONS AND DISCOUNT OFFERS VIA TEXT MESSAGES; PROVIDING ADVERTISING SERVICE TO DISTRIBUTE ADVERTISEMENTS FOR DISPLAY ON INTERNET, NAMELY, IN WEBSITES, SOCIAL CONVERSATIONS OVER THE INTERNET, E-MAILS, MICROBLOGS, BLOGS, ELECTRONIC MESSAGES, INSTANT MESSAGES, TEXT MESSAGES, MULTIMEDIA MESSAGES, SOCIAL NETWORKS, STATUS UPDATES, FORUMS, ELECTRONIC BULLETIN BOARDS; PUBLICATION OF PUBLICITY TEXTS; PUBLISHING OF ADVERTISING TEXTS (U.S. CLS. 100, 101 AND 102).

GRETNA YAO, EXAMINING ATTORNEY

SN 85-294,728. 412 LLC, DBA ARTJAIL, NEW YORK, NY. FILED 4-13-2011.

ARTJAIL

THE MARK CONSISTS OF STANDARD CHARACTERS WITHOUT CLAIM TO ANY PARTICULAR FONT, STYLE, SIZE, OR COLOR.

FOR ADVERTISING SERVICES, NAMELY, PRODUCTION OF SPECIAL EFFECTS IN THE NATURE OF MOTION IMAGERY, NAMELY, COMPUTER-GENERATED IMAGERY AND COMPUTER-GENERATED GRAPHICS FOR THE PRODUCTION OF COMMERCIALS; POST-PRODUCTION SERVICES, NAMELY, POST-PRODUCTION EDITING OF COMMERCIALS; ART GALLERIES; ART GALLERY SERVICES; ON-LINE ART GALLERIES (U.S. CLS. 100, 101 AND 102).

FIRST USE 7-14-2008; IN COMMERCE 7-14-2008.

DAWN FELDMAN, EXAMINING ATTORNEY

CLASS 35—(Continued).

SN 85-294,749. THODE, FABIOLA GLORIA, DBA CHERRY CREEK DIVAS, DENVER, CO. FILED 4-14-2011.

Divatise

THE MARK CONSISTS OF STANDARD CHARACTERS WITHOUT CLAIM TO ANY PARTICULAR FONT, STYLE, SIZE, OR COLOR.

FOR ADVERTISING AND MARKETING (U.S. CLS. 100, 101 AND 102).

FIRST USE 12-19-2010; IN COMMERCE 12-19-2010.
WILLIAM VERHOSEK, EXAMINING ATTORNEY

SN 85-294,859. PRETTY GIRLS ROCK DRESSES LLC, AUSTELL, GA. FILED 4-14-2011.

PRETTY GIRLS ROCK DRESSES

THE MARK CONSISTS OF STANDARD CHARACTERS WITHOUT CLAIM TO ANY PARTICULAR FONT, STYLE, SIZE, OR COLOR.

FOR PROMOTING PUBLIC INTEREST IN THE EMPOWERMENT OF WOMEN AND GIRLS THROUGH AWARENESS OF CLOTHING AND OTHER PERSONAL ATTRIBUTES AND ITS EFFECT ON SELF-ESTEEM AND SOCIAL RELATIONS (U.S. CLS. 100, 101 AND 102).

FIRST USE 1-26-2011; IN COMMERCE 1-26-2011.

KARANENDRA S. CHHINA, EXAMINING ATTORNEY

SN 85-294,959. U.S. MEDICAL MANAGEMENT LLC, FARMINGTON HILLS, MI. FILED 4-14-2011.

HOMESCRIPTS

THE MARK CONSISTS OF STANDARD CHARACTERS WITHOUT CLAIM TO ANY PARTICULAR FONT, STYLE, SIZE, OR COLOR.

OWNER OF U.S. REG. NO. 3,975,906.

FOR MAIL ORDER PHARMACY AND MAIL ORDER OVER THE COUNTER MEDICATION SERVICES; PHARMACEUTICAL SERVICES, NAMELY, PROCESSING MAIL ORDER, ON-LINE AND TELEPHONE PRESCRIPTION AND OVER THE COUNTER MEDICATION ORDERS; ON-LINE MAIL ORDER AND RETAIL PHARMACY SERVICES (U.S. CLS. 100, 101 AND 102).

MAYUR VAGHANI, EXAMINING ATTORNEY

CLASS 35—(Continued).

SN 85-294,989. FACES & VOICES OF RECOVERY, WASHINGTON, DC. FILED 4-14-2011.

Faces & Voices of Recovery

THE MARK CONSISTS OF STANDARD CHARACTERS WITHOUT CLAIM TO ANY PARTICULAR FONT, STYLE, SIZE, OR COLOR.

FOR PUBLIC ADVOCACY TO PROMOTE AWARENESS OF RECOVERY FROM ADDICTION TO ALCOHOL AND OTHER DRUGS (U.S. CLS. 100, 101 AND 102).
FIRST USE 9-11-2001; IN COMMERCE 9-11-2001.
INGRID C. EULIN, EXAMINING ATTORNEY

SN 85-295,091. HOME CARE TECHNOLOGY ASSOCIATION OF AMERICA, WASHINGTON, DC. FILED 4-14-2011.

HCTAA

THE MARK CONSISTS OF STANDARD CHARACTERS WITHOUT CLAIM TO ANY PARTICULAR FONT, STYLE, SIZE, OR COLOR.

FOR ASSOCIATION SERVICES, NAMELY, PROMOTING THE INTERESTS OF THE HOME CARE TECHNOLOGY INDUSTRY (U.S. CLS. 100, 101 AND 102).
FIRST USE 5-0-2005; IN COMMERCE 5-0-2005.
DAVID H. STINE, EXAMINING ATTORNEY

SN 85-295,095. CLEAR CHANNEL OUTDOOR, INC., SAN ANTONIO, TX. FILED 4-14-2011.

OUT WOWS

THE MARK CONSISTS OF STANDARD CHARACTERS WITHOUT CLAIM TO ANY PARTICULAR FONT, STYLE, SIZE, OR COLOR.

FOR OUT-OF-HOME ADVERTISING SERVICES, NAMELY, RENTAL OF ADVERTISING SPACE, AND PREPARING AND PLACING ADVERTISEMENTS FOR OTHERS (U.S. CLS. 100, 101 AND 102).
FIRST USE 9-30-2010; IN COMMERCE 9-30-2010.
WILLIAM BRECKENFELD, EXAMINING ATTORNEY

CLASS 35—(Continued).

SN 85-295,156. LOENS, CLAUDIA, SAN JOSE, CA. FILED 4-14-2011.



Wordflirt

THE MARK CONSISTS OF THE STYLIZED WORD "WORDFLIRT" AND A FLOWER THAT IS THE DOT ON THE LETTER "I".

FOR BUSINESS MARKETING SERVICES; WRITING OF PUBLICITY TEXTS (U.S. CLS. 100, 101 AND 102).
FIRST USE 2-1-2002; IN COMMERCE 1-1-2009.
SETH A. RAPPAPORT, EXAMINING ATTORNEY

SN 85-295,399. MEDICAL TECHNOLOGIES PRODUCTS INC., RIVIERA BEACH, FL. FILED 4-14-2011.

ACU-MARKET

THE MARK CONSISTS OF STANDARD CHARACTERS WITHOUT CLAIM TO ANY PARTICULAR FONT, STYLE, SIZE, OR COLOR.

FOR ONLINE WHOLESALE AND RETAIL STORE SERVICES FEATURING ELECTRIC ACUPUNCTURE EQUIPMENT, NON-ELECTRIC ACUPUNCTURE EQUIPMENT, ACUPUNCTURE INSTRUMENTS, ACUPUNCTURE NEEDLES, APPARATUSES FOR ACUPUNCTURE, BOOKS IN THE FIELD OF ACUPUNCTURE, HERBAL SUPPLEMENTS, HOMEOPATHIC SUPPLEMENTS, VITAMINS, MASSAGE LOTIONS, MASSAGE OILS, GLOVES FOR MASSAGE, MASSAGE CHAIRS, CONTAINERS FOR MEDICAL WASTE, MEDICAL GLOVES, INJECTION NEEDLES, MOXA USED FOR HEAT THERAPY, CUPPING INSTRUMENTS, TENS UNITS, AND MEDICAL SYRINGES; WHOLESALE PHARMACY SERVICES (U.S. CLS. 100, 101 AND 102).
FIRST USE 1-0-2001; IN COMMERCE 1-0-2001.
DAVID H. STINE, EXAMINING ATTORNEY

SN 85-295,454. KIMONS MOVING, INC., MANHASSET, NY. FILED 4-14-2011.

The Velvet Touch

THE MARK CONSISTS OF STANDARD CHARACTERS WITHOUT CLAIM TO ANY PARTICULAR FONT, STYLE, SIZE, OR COLOR.

FOR MOVING AND RELOCATION SERVICES, NAMELY, PLANNING AND IMPLEMENTING MOVES OF HOMES AND OFFICES (U.S. CLS. 100, 101 AND 102).
FIRST USE 3-0-2000; IN COMMERCE 7-0-2000.
NATALIE POLZER, EXAMINING ATTORNEY

CLASS 35—(Continued).

SN 85-295,494. COLLECTIVE ALLIANCE, LLC, SPRINGFIELD GARDENS, NY. FILED 4-14-2011.

GOLDLINE

THE MARK CONSISTS OF STANDARD CHARACTERS WITHOUT CLAIM TO ANY PARTICULAR FONT, STYLE, SIZE, OR COLOR.

FOR TAX PREPARATION (U.S. CLS. 100, 101 AND 102).

FIRST USE 5-21-2010; IN COMMERCE 5-21-2010.
LINDA M. KING, EXAMINING ATTORNEY

CLASS 35—(Continued).

SN 85-295,576. XV EXCLUSIVES, INC, MONTCLAIR, NJ. FILED 4-14-2011.

Feel The Euphoria

THE MARK CONSISTS OF STANDARD CHARACTERS WITHOUT CLAIM TO ANY PARTICULAR FONT, STYLE, SIZE, OR COLOR.

FOR WHOLESALE AND RETAIL STORE SERVICES FEATURING ICEWINE AND CONFECTIONS (U.S. CLS. 100, 101 AND 102).

FIRST USE 4-8-2011; IN COMMERCE 4-8-2011.
STEPHANIE ALI, EXAMINING ATTORNEY

SN 85-295,604. THE KYLE FRANKS FOUNDATION INC., TUCSON, AZ. FILED 4-14-2011.

SN 85-295,531. MILE OF CARS ASSOCIATION, INC., NATIONAL CITY, CA. FILED 4-14-2011.



toughstreet

THE MARK CONSISTS OF STANDARD CHARACTERS WITHOUT CLAIM TO ANY PARTICULAR FONT, STYLE, SIZE, OR COLOR.

FOR ADVERTISING AND MARKETING SERVICES, NAMELY, PROMOTING THE GOODS AND SERVICES OF OTHERS (U.S. CLS. 100, 101 AND 102).

ODESSA BIBBINS, EXAMINING ATTORNEY

SN 85-295,723. ANTONIO CARMELO CULICETTO, MIAMI, FL. FILED 4-14-2011.

OWNER OF U.S. REG. NOS. 2,663,234, 2,727,118 AND 2,943,948.

NO CLAIM IS MADE TO THE EXCLUSIVE RIGHT TO USE "NATIONAL CITY" AND "CARS", APART FROM THE MARK AS SHOWN.

THE MARK CONSISTS OF A CIRCLE DESIGN WHERE THE WORDS "MILE OF CARS" ARE SET WITHIN THE CIRCLE AND THE WORDS "NATIONAL CITY" ARE SET OVER THE TOP OF THE CIRCLE.

FOR ADVERTISING AND PROMOTING THE GOODS AND SERVICES OF AUTOMOBILE DEALERS BY BANNERS, TELEVISION ADVERTISING, POSTERS, PRINT ADVERTISING, BILLBOARD ADVERTISING, RADIO ADVERTISING, AND INTERNET ADVERTISING (U.S. CLS. 100, 101 AND 102).

FIRST USE 12-1-2009; IN COMMERCE 12-1-2009.
ANNE E. GUSTASON, EXAMINING ATTORNEY

PICCADILLY CLOUD

THE MARK CONSISTS OF STANDARD CHARACTERS WITHOUT CLAIM TO ANY PARTICULAR FONT, STYLE, SIZE, OR COLOR.

FOR MAIL ORDER CATALOG SERVICES FEATURING SHOES; ON-LINE RETAIL STORE SERVICES FEATURING SHOES; RETAIL STORE SERVICES FEATURING SHOES (U.S. CLS. 100, 101 AND 102).

TEJBIR SINGH, EXAMINING ATTORNEY

CLASS 35—(Continued).

SN 85-295,756. OLSON, TODD, AUSTIN, TX. FILED 4-14-2011.

THEDEALYO

THE MARK CONSISTS OF STANDARD CHARACTERS WITHOUT CLAIM TO ANY PARTICULAR FONT, STYLE, SIZE, OR COLOR.

FOR PROMOTING THE GOODS AND SERVICES OF OTHERS BY PROVIDING A WEB SITE FEATURING COUPONS, REBATES, PRICE-COMPARISON INFORMATION, PRODUCT REVIEWS, LINKS TO THE RETAIL WEB SITES OF OTHERS, AND DISCOUNT INFORMATION (U.S. CLS. 100, 101 AND 102).

FIRST USE 12-19-2009; IN COMMERCE 12-19-2009.
 NAAKWAMA ANKRAH, EXAMINING ATTORNEY

CLASS 35—(Continued).

SN 85-296,760. NORTHEAST ENERGY EFFICIENCY PARTNERSHIPS, INC., LEXINGTON, MA. FILED 4-15-2011.



THE COLOR(S) TEAL AND WHITE IS/ARE CLAIMED AS A FEATURE OF THE MARK.

THE MARK CONSISTS OF THE LOWERCASE LETTERS "N", "E", "E", AND "P" ARRANGED IN A SQUARE. THE LETTERS ARE WHITE AND THE BOTH "E" LETTERS ARE STYLIZED TO LOOK LIKE ELECTRICAL METERS. THE LETTERS ARE ENCLOSED IN A TEAL COLORED SQUARE WITH ROUNDED EDGES.

FOR INFORMATION IN THE FIELD OF ENERGY EFFICIENCY (U.S. CLS. 100, 101 AND 102).

FIRST USE 5-31-2009; IN COMMERCE 5-31-2009.
 CHRISTINA SOBRAL, EXAMINING ATTORNEY

SN 85-296,774. HAHN CONSULTING SERVICES, WESTMINSTER, CO. FILED 4-15-2011.

Come Smell The Ocean in Your Hair

THE MARK CONSISTS OF STANDARD CHARACTERS WITHOUT CLAIM TO ANY PARTICULAR FONT, STYLE, SIZE, OR COLOR.

FOR PROMOTING TOURISM IN THE CARIBBEAN AND HAWAIIAN ISLANDS AREA (U.S. CLS. 100, 101 AND 102).

COURTNEY ALVAREZ, EXAMINING ATTORNEY

SN 85-296,871. EMJAY CREATIVE, INC., DBA HUTDOGS, ARCADIA, CA. FILED 4-15-2011.

HUTdogs

THE MARK CONSISTS OF STANDARD CHARACTERS WITHOUT CLAIM TO ANY PARTICULAR FONT, STYLE, SIZE, OR COLOR.

FOR CREATIVE MARKETING DESIGN SERVICES (U.S. CLS. 100, 101 AND 102).

FIRST USE 2-1-2004; IN COMMERCE 2-1-2004.
 JOHN WILKE, EXAMINING ATTORNEY

SN 85-296,625. AUTHENTEC, INC., MELBOURNE, FL. FILED 4-15-2011.

FIDO

THE MARK CONSISTS OF STANDARD CHARACTERS WITHOUT CLAIM TO ANY PARTICULAR FONT, STYLE, SIZE, OR COLOR.

FOR ASSOCIATION SERVICES, NAMELY, PROMOTING THE INTERESTS OF A BUSINESS NETWORK TO FACILITATE AND PROTECT DIGITAL TRANSMISSION OF PERSONAL INFORMATION, SOCIAL NETWORKING, ONLINE COMMERCE, AND PRIVACY; PROMOTING A STANDARD PROTOCOL AND INTERFACE DEFINITIONS FOR THE BUSINESS NETWORK; PROMOTING THE INTERESTS OF INTEROPERABILITY AND A CERTIFICATION PROGRAM FOR THE BUSINESS NETWORK (U.S. CLS. 100, 101 AND 102).

ANDREA HACK, EXAMINING ATTORNEY

CLASS 35—(Continued).

SN 85-296,916. RESTEGHINI, MARTHA, LOS ANGELES, CA. FILED 4-15-2011.

The Tribal Chef

THE MARK CONSISTS OF STANDARD CHARACTERS WITHOUT CLAIM TO ANY PARTICULAR FONT, STYLE, SIZE, OR COLOR.

FOR ONLINE ADVERTISEMENTS (U.S. CLS. 100, 101 AND 102).

PATRICIA EVANKO, EXAMINING ATTORNEY

SN 85-296,924. LAWRENCE, MALIA, SAN JOSE, CA. FILED 4-15-2011.

The Intergalactic Nerd

THE MARK CONSISTS OF STANDARD CHARACTERS WITHOUT CLAIM TO ANY PARTICULAR FONT, STYLE, SIZE, OR COLOR.

FOR WHOLESALE AND RETAIL STORE SERVICES FEATURING BAGS, CLOTHING, AND ACCESSORIES (U.S. CLS. 100, 101 AND 102).

DORITT L. CARROLL, EXAMINING ATTORNEY

SN 85-298,450. CLEAR CHANNEL OUTDOOR, INC., SAN ANTONIO, TX. FILED 4-19-2011.

OUT REACHES

THE MARK CONSISTS OF STANDARD CHARACTERS WITHOUT CLAIM TO ANY PARTICULAR FONT, STYLE, SIZE, OR COLOR.

FOR OUT-OF-HOME ADVERTISING SERVICES, NAMELY, RENTAL OF ADVERTISING SPACE, AND PREPARING AND PLACING ADVERTISEMENTS FOR OTHERS (U.S. CLS. 100, 101 AND 102).

WILLIAM BRECKENFELD, EXAMINING ATTORNEY

CLASS 35—(Continued).

SN 85-298,460. CLEAR CHANNEL OUTDOOR, INC., SAN ANTONIO, TX. FILED 4-19-2011.

OUT DELIVERS

THE MARK CONSISTS OF STANDARD CHARACTERS WITHOUT CLAIM TO ANY PARTICULAR FONT, STYLE, SIZE, OR COLOR.

FOR OUT-OF-HOME ADVERTISING SERVICES, NAMELY, RENTAL OF ADVERTISING SPACE, AND PREPARING AND PLACING ADVERTISEMENTS FOR OTHERS (U.S. CLS. 100, 101 AND 102).

WILLIAM BRECKENFELD, EXAMINING ATTORNEY

SN 85-302,752. TARJEFT, CHRISTOPHER T, GROSSE POINTE, MI. FILED 4-22-2011.

What's your line?

THE MARK CONSISTS OF STANDARD CHARACTERS WITHOUT CLAIM TO ANY PARTICULAR FONT, STYLE, SIZE, OR COLOR.

FOR ADVERTISING AGENCY SPECIALIZING IN THE DESIGN AND EXECUTION OF WORD OF MOUTH, VIRAL, BUZZ AND EXPERIENTIAL MARKETING PROGRAMS; ADVERTISING AND ADVERTISEMENT SERVICES; ADVERTISING AND BUSINESS MANAGEMENT CONSULTANCY; ADVERTISING AND BUSINESS SERVICES, NAMELY, PROVIDING AN ONLINE WEBSITE WHERE ADVERTISERS, MARKETERS, AND CONTENT PROVIDERS CAN INTERACT WITH USERS FOR ADVERTISING, BRANDING, AND PROMOTING KNOWLEDGE, PRODUCTS, AND SERVICES, AND TRADESHOWS, ON BEHALF OF THEMSELVES AND OTHERS, AND FOR EVALUATING AND RATING THE SAME, ALL THE FOREGOING RELEVANT TO HUMAN ACTIVITIES AFFECTING CLIMATE CHANGE AND RELATED FIELDS; ADVERTISING AND COMMERCIAL INFORMATION SERVICES, VIA THE INTERNET; ADVERTISING AND DIRECTORY SERVICES, NAMELY, PROMOTING THE SERVICES OF OTHERS BY PROVIDING A WEB PAGE FEATURING LINKS TO THE WEBSITES OF OTHERS; ADVERTISING AND MARKETING SERVICES PROVIDED BY MEANS OF INDIRECT METHODS OF MARKETING COMMUNICATIONS, NAMELY, SOCIAL MEDIA, SEARCH ENGINE MARKETING, INQUIRY MARKETING, INTERNET MARKETING, MOBILE MARKETING, BLOGGING AND OTHER FORMS OF PASSIVE, SHARABLE OR VIRAL COMMUNICATIONS CHANNELS (U.S. CLS. 100, 101 AND 102).

JENNIFER MARTIN, EXAMINING ATTORNEY

CLASS 35—(Continued).

SN 85-304,773. AGENCYRTS, LLC, HOLBROOK, NY. FILED 4-26-2011.

**EMBARK ON A BRIGHTER
FUTURE, TODAY!**

THE MARK CONSISTS OF STANDARD CHARACTERS WITHOUT CLAIM TO ANY PARTICULAR FONT, STYLE, SIZE, OR COLOR.

FOR HUMAN RESOURCES, EMPLOYMENT RECRUITING AND STAFFING CONSULTING SERVICES IN THE FIELDS OF CAREER SERVICES, PLACEMENT, RECRUITMENT, AND CERTIFICATION IN THE INSURANCE AND FINANCIAL SERVICES INDUSTRIES (U.S. CLS. 100, 101 AND 102).

FIRST USE 9-1-2010; IN COMMERCE 9-1-2010.

ELISSA GARBER KON, EXAMINING ATTORNEY

SN 85-304,780. MOFTWARE, INC., SUGAR LAND, CA. FILED 4-26-2011.



The logo for Fommy.com features the word "fommy" in a bold, lowercase, sans-serif font. The letter "o" is red and has a red rectangular protrusion on its upper left side and two red dots below it. The ".com" is in a smaller, lowercase, sans-serif font and is red.

OWNER OF U.S. REG. NOS. 3,284,753 AND 3,284,754. THE COLOR(S) RED AND BLACK IS/ARE CLAIMED AS A FEATURE OF THE MARK.

THE MARK CONSISTS OF THE WORDING "FOMMY.COM" IN STYLIZED FONT; THE LETTER "F" IS IN BLACK, THE LETTER "O" IN "FOMMY" IS IN RED AND HAS A RED RECTANGULAR PROTRUSION ON THE UPPER LEFT AND HAS TWO RED DOTS BELOW IT; THE LETTERS "MMY" ARE IN BLACK AND THE WORDING ".COM" IS IN RED.

FOR RETAIL STORE AND ON-LINE RETAIL STORE SERVICES FEATURING TELEPHONES, CELL PHONES, PERSONAL ELECTRONIC DEVICES, ELECTRONIC HAND HELD DEVICES, SMART PHONES, BATTERIES, CABLES, CASES, CHARGERS, CRADLES, HEADPHONES, HEADSETS, MEMORY CARDS, SCREEN PROTECTORS, PHONES, COMPUTER SOFTWARE, SMALL BUSINESS SOFTWARE, ENTERPRISE SOFTWARE, SERVER SOFTWARE, SPEAKERS, STEREO SYSTEMS, NETWORKING EQUIPMENT AND RELATED ACCESSORIES AND EQUIPMENT THEREOF (U.S. CLS. 100, 101 AND 102).

DAVID ELTON, EXAMINING ATTORNEY

CLASS 35—(Continued).

SN 85-304,788. MOFTWARE, INC., SUGAR LAND, CA. FILED 4-26-2011.



THE COLOR(S) RED IS/ARE CLAIMED AS A FEATURE OF THE MARK.

THE MARK CONSISTS OF A RED STYLIZED LETTER "O" WITH A RED RECTANGULAR PROTRUSION ON THE UPPER LEFT AND TWO RED DOTS BELOW.

FOR RETAIL STORE AND ON-LINE RETAIL STORE SERVICES FEATURING TELEPHONES, CELL PHONES, PERSONAL ELECTRONIC DEVICES, ELECTRONIC HAND HELD DEVICES, SMART PHONES, BATTERIES, CABLES, CASES, CHARGERS, CRADLES, HEADPHONES, HEADSETS, MEMORY CARDS, SCREEN PROTECTORS, PHONES, COMPUTER SOFTWARE, SMALL BUSINESS SOFTWARE, ENTERPRISE SOFTWARE, SERVER SOFTWARE, SPEAKERS, STEREO SYSTEMS, NETWORKING EQUIPMENT AND RELATED ACCESSORIES AND EQUIPMENT THEREOF (U.S. CLS. 100, 101 AND 102).

DAVID ELTON, EXAMINING ATTORNEY

SN 85-306,397. MELALEUCA, INC., IDAHO FALLS, ID. FILED 4-27-2011.

**CLEAN HOME. CLEAN STREAMS.
CLEAN CONSCIENCE.**

THE MARK CONSISTS OF STANDARD CHARACTERS WITHOUT CLAIM TO ANY PARTICULAR FONT, STYLE, SIZE, OR COLOR.

FOR INTERNET AND MAIL ORDER CATALOG SERVICES FEATURING LAUNDRY CARE PRODUCTS, CLEANERS, SOAPS, DISHWASHER DETERGENTS, AIR FRESHENERS, DETERGENTS AND DISINFECTANTS, HEALTH CARE PRODUCTS, NUTRITIONAL SUPPLEMENTS, DIETARY SUPPLEMENTS, VITAMIN AND MINERAL SUPPLEMENTS, NUTRITIOUS FOODS, SNACKS AND BEVERAGES, COSMETICS, SKIN CARE PRODUCTS, AND TOILETRIES (U.S. CLS. 100, 101 AND 102).

FIRST USE 4-0-2011; IN COMMERCE 4-0-2011.

SUSAN LESLIE DUBOIS, EXAMINING ATTORNEY

CLASS 35—(Continued).

SN 85-306,843. FANPLAY, INC., SLATON, TX. FILED 4-28-2011.

FANPLAY WE ARE "TEAM"
SPORTS

THE MARK CONSISTS OF STANDARD CHARACTERS WITHOUT CLAIM TO ANY PARTICULAR FONT, STYLE, SIZE, OR COLOR.
FOR ADVERTISING, MARKETING AND PROMOTION SERVICES (U.S. CLS. 100, 101 AND 102).
LESLIE RICHARDS, EXAMINING ATTORNEY

SN 85-306,890. ILLUSTRATION GALLERY INC., NEW YORK, NY. FILED 4-28-2011.

Art That Pops

THE MARK CONSISTS OF STANDARD CHARACTERS WITHOUT CLAIM TO ANY PARTICULAR FONT, STYLE, SIZE, OR COLOR.
NO CLAIM IS MADE TO THE EXCLUSIVE RIGHT TO USE "ART", APART FROM THE MARK AS SHOWN.
FOR ON-LINE ART GALLERIES (U.S. CLS. 100, 101 AND 102).
CHRISTINE MARTIN, EXAMINING ATTORNEY

SN 85-307,434. AMERICAN INTERNATIONAL GROUP, INC., NEW YORK, NY. FILED 4-28-2011.

AQX

THE MARK CONSISTS OF STANDARD CHARACTERS WITHOUT CLAIM TO ANY PARTICULAR FONT, STYLE, SIZE, OR COLOR.
FOR BUSINESS EVALUATION OF MORTGAGE GUARANTY INSURANCE RISK (U.S. CLS. 100, 101 AND 102).
NAAKWAMA ANKRAH, EXAMINING ATTORNEY

CLASS 35—(Continued).

SN 85-307,437. AMERICAN INTERNATIONAL GROUP, INC., NEW YORK, NY. FILED 4-28-2011.

BQX

THE MARK CONSISTS OF STANDARD CHARACTERS WITHOUT CLAIM TO ANY PARTICULAR FONT, STYLE, SIZE, OR COLOR.
FOR BUSINESS EVALUATION OF MORTGAGE GUARANTY INSURANCE RISK (U.S. CLS. 100, 101 AND 102).
NAAKWAMA ANKRAH, EXAMINING ATTORNEY

SN 85-307,439. AMERICAN INTERNATIONAL GROUP, INC., NEW YORK, NY. FILED 4-28-2011.

BRX

THE MARK CONSISTS OF STANDARD CHARACTERS WITHOUT CLAIM TO ANY PARTICULAR FONT, STYLE, SIZE, OR COLOR.
FOR BUSINESS EVALUATION OF MORTGAGE GUARANTY INSURANCE RISK (U.S. CLS. 100, 101 AND 102).
NAAKWAMA ANKRAH, EXAMINING ATTORNEY

SN 85-307,442. AMERICAN INTERNATIONAL GROUP, INC., NEW YORK, NY. FILED 4-28-2011.

FQX

THE MARK CONSISTS OF STANDARD CHARACTERS WITHOUT CLAIM TO ANY PARTICULAR FONT, STYLE, SIZE, OR COLOR.
FOR BUSINESS EVALUATION OF MORTGAGE GUARANTY INSURANCE RISK (U.S. CLS. 100, 101 AND 102).
NAAKWAMA ANKRAH, EXAMINING ATTORNEY

CLASS 35—(Continued).

SN 85-307,992. AMERICAN INSTITUTE OF CERTIFIED PUBLIC ACCOUNTANTS, NEW YORK, NY. FILED 4-29-2011.



OWNER OF U.S. REG. NO. 3,947,982.
NO CLAIM IS MADE TO THE EXCLUSIVE RIGHT TO USE "CPA", APART FROM THE MARK AS SHOWN.

THE MARK CONSISTS OF A GENERALLY RECTANGULAR BOX WITH THE STYLIZED WORDS "THIS WAY TO" WITH AN ARROW CONTAINING THE LETTERS "CPA" TRAVERSING PART OF THE BOX.

FOR ASSOCIATION SERVICES, NAMELY, PROMOTING THE INTERESTS OF ACCOUNTANTS; PROMOTING PUBLIC AWARENESS OF THE STUDY OF ACCOUNTING AND THE NEED FOR ACCOUNTANTS (U.S. CLS. 100, 101 AND 102).

FIRST USE 9-13-2010; IN COMMERCE 9-13-2010.

NICHOLAS COLEMAN, EXAMINING ATTORNEY

CLASS 35—(Continued).

SN 85-308,897. ICONOSYS, INC., LAGUNA NIGUEL, CA. FILED 4-29-2011.

ADSHARK

THE MARK CONSISTS OF STANDARD CHARACTERS WITHOUT CLAIM TO ANY PARTICULAR FONT, STYLE, SIZE, OR COLOR.

FOR DISSEMINATION OF ADVERTISING FOR OTHERS VIA AN ON-LINE COMMUNICATIONS NETWORK ON THE INTERNET; DISSEMINATION OF ADVERTISING FOR OTHERS VIA PUBLIC AND PRIVATE WIRELESS NETWORKS FOR DISPLAY ON MOBILE DEVICES; DISSEMINATION OF ADVERTISING FOR OTHERS VIA THE INTERNET; DISSEMINATION SERVICES OF ADVERTISEMENT MATTER; DISTRIBUTION OF ADVERTISEMENTS AND COMMERCIAL ANNOUNCEMENTS; DISTRIBUTION OF ADVERTISING MATERIAL; PROVIDING A WEB SITE WHICH FEATURES ADVERTISEMENTS FOR THE GOODS AND SERVICES OF OTHERS ON A GLOBAL COMPUTER NETWORK; PROVIDING ADVERTISING AND ADVERTISEMENT SERVICES; PROVIDING ADVERTISING SERVICE TO DISTRIBUTE ADVERTISEMENTS FOR DISPLAY ON INTERNET, NAMELY, IN WEBSITES, SOCIAL CONVERSATIONS OVER THE INTERNET, E-MAILS, MICROBLOGS, BLOGS, ELECTRONIC MESSAGES, INSTANT MESSAGES, TEXT MESSAGES, MULTIMEDIA MESSAGES, SOCIAL NETWORKS, STATUS UPDATES, FORUMS, ELECTRONIC BULLETIN BOARDS; PROVIDING ON-LINE BUSINESS INFORMATION OF OTHERS, NAMELY, ADVERTISEMENTS OR SOLICITATIONS; PROVIDING SPACE AT A WEB SITE FOR THE ADVERTISEMENT OF THE GOODS AND SERVICES OF OTHERS; PROVISION OF ADVERTISING SPACE BY ELECTRONIC MEANS AND GLOBAL INFORMATION NETWORKS; PROVISION OF SPACE ON WEBSITES FOR ADVERTISING GOODS AND SERVICES (U.S. CLS. 100, 101 AND 102).

JACLYN KIDWELL WALKER, EXAMINING ATTORNEY

SN 85-309,709. ENTERPRISE HOLDINGS, INC., ST. LOUIS, MO. FILED 5-2-2011.



NO CLAIM IS MADE TO THE EXCLUSIVE RIGHT TO USE "ALLIANCE", APART FROM THE MARK AS SHOWN. THE COLOR(S) GREEN AND WHITE IS/ARE CLAIMED AS A FEATURE OF THE MARK.

THE MARK CONSISTS OF A LETTER "D" AND THE WORDS "DRIVE ALLIANCE" IN WHITE AGAINST A GREEN SQUARE BACKGROUND.

FOR CUSTOMER LOYALTY SERVICES AND CUSTOMER CLUB SERVICES, FOR COMMERCIAL, PROMOTIONAL AND/OR ADVERTISING PURPOSES (U.S. CLS. 100, 101 AND 102).

KIMBERLY FRYE, EXAMINING ATTORNEY

CLASS 35—(Continued).

SN 85-311,748. THE DORSCHER GROUP, AKA DORSCHER AUTOMOTIVE GROUP, WEST HENRIETTA, NY. FILED 5-4-2011.

clear. simple. different.

THE MARK CONSISTS OF STANDARD CHARACTERS WITHOUT CLAIM TO ANY PARTICULAR FONT, STYLE, SIZE, OR COLOR.

FOR AUTOMOBILE DEALERSHIPS (U.S. CLS. 100, 101 AND 102).

FIRST USE 4-1-2011; IN COMMERCE 4-1-2011.

CARRIE GENOVESE, EXAMINING ATTORNEY

CLASS 35—(Continued).

SN 85-321,974. ORLANDO/ORANGE COUNTY CONVENTION & VISITORS BUREAU, INC., ORLANDO, FL. FILED 5-16-2011.

SECOND SUMMER

THE MARK CONSISTS OF STANDARD CHARACTERS WITHOUT CLAIM TO ANY PARTICULAR FONT, STYLE, SIZE, OR COLOR.

FOR PROMOTIONAL SERVICES, NAMELY, THE PROMOTION OF TOURISM AND CONVENTIONS IN THE ORLANDO AREA (U.S. CLS. 100, 101 AND 102).

GINA HAYES, EXAMINING ATTORNEY

SN 85-318,927. MEDCO HEALTH SOLUTIONS, INC., FRANKLIN LAKES, NJ. FILED 5-12-2011.

Meds at Home

NO CLAIM IS MADE TO THE EXCLUSIVE RIGHT TO USE "MEDS", APART FROM THE MARK AS SHOWN.

THE MARK CONSISTS OF THE WORDS "MEDS AT HOME" WITH A RIGHT POINTING ARROW AGAINST AN OPEN CIRCLE DESIGN SURROUNDING THE WORD "AT".

FOR DRUG UTILIZATION REVIEW SERVICES; MAIL ORDER AND ON-LINE RETAIL PHARMACY SERVICES (U.S. CLS. 100, 101 AND 102).

CHRISTINA SOBRAL, EXAMINING ATTORNEY

SN 85-322,246. PETSMART STORE SUPPORT GROUP, INC., PHOENIX, AZ. FILED 5-16-2011.

CONNECT AND CELEBRATE WITH
EVERY PARENT, EVERY PET,
EVERY TIME

THE MARK CONSISTS OF STANDARD CHARACTERS WITHOUT CLAIM TO ANY PARTICULAR FONT, STYLE, SIZE, OR COLOR.

FOR RETAIL STORE SERVICES AND ON-LINE RETAIL STORE SERVICES, FEATURING PET FOOD, PET SUPPLIES AND PET ACCESSORIES (U.S. CLS. 100, 101 AND 102).

RUSS HERMAN, EXAMINING ATTORNEY

SN 85-319,285. 1STDIBS.COM, INC., NEW YORK, NY. FILED 5-12-2011.

THE FRENCH RESISTANCE

THE MARK CONSISTS OF STANDARD CHARACTERS WITHOUT CLAIM TO ANY PARTICULAR FONT, STYLE, SIZE, OR COLOR.

FOR ON-LINE RETAIL STORE SERVICES IN THE FIELD OF COOKING PRODUCTS, COOKING UTENSILS, COOKBOOKS AND INGREDIENTS (U.S. CLS. 100, 101 AND 102).

JAMES A. RAUEN, EXAMINING ATTORNEY

SN 85-322,251. PETSMART STORE SUPPORT GROUP, INC., PHOENIX, AZ. FILED 5-16-2011.

CONNECT AND CELEBRATE

THE MARK CONSISTS OF STANDARD CHARACTERS WITHOUT CLAIM TO ANY PARTICULAR FONT, STYLE, SIZE, OR COLOR.

FOR RETAIL STORE SERVICES AND ON-LINE RETAIL STORE SERVICES, FEATURING PET FOOD, PET SUPPLIES AND PET ACCESSORIES (U.S. CLS. 100, 101 AND 102).

RUSS HERMAN, EXAMINING ATTORNEY

CLASS 35—(Continued).

SN 85-323,607. WHOZAGOOD, INC., CALGARY, CANADA, FILED 5-18-2011.

WHOZABEST

THE MARK CONSISTS OF STANDARD CHARACTERS WITHOUT CLAIM TO ANY PARTICULAR FONT, STYLE, SIZE, OR COLOR.

FOR BUSINESS RESEARCH AND SURVEYS; CONDUCTING ON-LINE BUSINESS MANAGEMENT RESEARCH SURVEYS; PROVIDING A SEARCHABLE WEBSITE FEATURING THE GOODS AND SERVICES OF OTHER VENDORS; PROVIDING A WEB SITE WHERE USERS CAN POST RATINGS, REVIEWS AND RECOMMENDATIONS ON PRODUCTS AND SERVICES FOR COMMERCIAL PURPOSES (U.S. CLS. 100, 101 AND 102).

JILL C. ALT, EXAMINING ATTORNEY

SN 85-324,654. HATCH LABS, INC., NEW YORK, NY. FILED 5-19-2011.

APPEXPLORER

THE MARK CONSISTS OF STANDARD CHARACTERS WITHOUT CLAIM TO ANY PARTICULAR FONT, STYLE, SIZE, OR COLOR.

FOR DISSEMINATION OF ADVERTISING FOR OTHERS VIA WIRELESS AND MOBILE DEVICES AND ONLINE APPLICATIONS AND WEBSITES; ONLINE AND WIRELESS ADVERTISING SERVICES FOR OTHERS (U.S. CLS. 100, 101 AND 102).

NICHOLAS COLEMAN, EXAMINING ATTORNEY

SN 85-324,761. METROPCS WIRELESS, INC., RICHARDSON, TX. FILED 5-19-2011.

METROHERO

THE MARK CONSISTS OF STANDARD CHARACTERS WITHOUT CLAIM TO ANY PARTICULAR FONT, STYLE, SIZE, OR COLOR.

FOR CONDUCTING EMPLOYEE INCENTIVE AWARD PROGRAMS TO PROMOTE PRODUCT KNOWLEDGE AND AWARENESS, QUALITY, PRODUCTIVITY, AND JOB SKILLS (U.S. CLS. 100, 101 AND 102).

ANDREW LEASER, EXAMINING ATTORNEY

CLASS 35—(Continued).

SN 85-325,089. UMB FINANCIAL CORPORATION, KANSAS CITY, MO. FILED 5-19-2011.

COMPLIANCEFOCUS

THE MARK CONSISTS OF STANDARD CHARACTERS WITHOUT CLAIM TO ANY PARTICULAR FONT, STYLE, SIZE, OR COLOR.

OWNER OF U.S. REG. NO. 3,058,302.

SEC. 2(F).

FOR SUPPORT SERVICES WITH RESPECT TO COMPLIANCE WITH SECURITIES LAWS AND REGULATIONS, NAMELY, BUSINESS CONSULTING SERVICES IN THE FIELD OF COMPLIANCE WITH SECURITIES LAWS AND REGULATIONS (U.S. CLS. 100, 101 AND 102).

FIRST USE 3-25-2005; IN COMMERCE 3-25-2005.
CHRISTINA SOBRAL, EXAMINING ATTORNEY

SN 85-326,656. WONTON MEDIA INC., VANCOUVER, BC, CANADA, FILED 5-21-2011.

WINONA WONTON

THE MARK CONSISTS OF STANDARD CHARACTERS WITHOUT CLAIM TO ANY PARTICULAR FONT, STYLE, SIZE, OR COLOR.

FOR ADVERTISING, PROMOTION, AND MARKETING SERVICES IN THE NATURE OF FEATURING COUPONS, DISCOUNTS, REBATES, PRICE-COMPARISON INFORMATION, PRODUCT REVIEWS, AND LINKS TO THE RETAIL WEBSITES OF OTHERS VIA A GLOBAL COMPUTER NETWORK FOR CONSUMERS (U.S. CLS. 100, 101 AND 102).

FIRST USE 5-18-2011; IN COMMERCE 5-18-2011.
ANTHONY RINKER, EXAMINING ATTORNEY

SN 85-326,658. WONTON MEDIA INC., VANCOUVER, BC, CANADA, FILED 5-21-2011.

IT'S ALWAYS THE WEEKEND!

THE MARK CONSISTS OF STANDARD CHARACTERS WITHOUT CLAIM TO ANY PARTICULAR FONT, STYLE, SIZE, OR COLOR.

FOR ADVERTISING, PROMOTION, AND MARKETING SERVICES IN THE NATURE OF FEATURING COUPONS, DISCOUNTS, REBATES, PRICE-COMPARISON INFORMATION, PRODUCT REVIEWS, AND LINKS TO THE RETAIL WEBSITES OF OTHERS VIA A GLOBAL COMPUTER NETWORK FOR CONSUMERS (U.S. CLS. 100, 101 AND 102).

FIRST USE 5-18-2011; IN COMMERCE 5-18-2011.
ANTHONY RINKER, EXAMINING ATTORNEY

CLASS 35—(Continued).

SN 85-328,145. ONLY IN, LLC, NEW YORK, NY. FILED 5-24-2011.

ONLY IN NEW YORK

THE MARK CONSISTS OF STANDARD CHARACTERS WITHOUT CLAIM TO ANY PARTICULAR FONT, STYLE, SIZE, OR COLOR.

OWNER OF U.S. REG. NOS. 3,610,532, 3,703,624 AND OTHERS.

NO CLAIM IS MADE TO THE EXCLUSIVE RIGHT TO USE "NEW YORK", APART FROM THE MARK AS SHOWN. FOR ADVERTISING SERVICES (U.S. CLS. 100, 101 AND 102).

JAMES STEIN, EXAMINING ATTORNEY

SN 85-328,189. THE WORLDS BIGGEST BUYING CLUB, INC., CROWNSVILLE, MD. FILED 5-24-2011.

SHOP.SAVE.ENJOY.

THE MARK CONSISTS OF STANDARD CHARACTERS WITHOUT CLAIM TO ANY PARTICULAR FONT, STYLE, SIZE, OR COLOR.

FOR ON-LINE RETAIL STORE SERVICES FEATURING CLOTHING, ACCESSORIES, OFFICE PRODUCTS, ATHLETIC APPAREL AND EQUIPMENT, FOOTWEAR, TRANSPORTATION-RELATED PRODUCTS, HOME FURNISHINGS, PET PRODUCTS, BUSINESS AND FINANCIAL SERVICES, HEALTH AND BEAUTY ITEMS, ELECTRONICS AND APPLIANCES, HOME AND GARDEN, INDUSTRIAL PARTS, TRAVEL, ENTERTAINMENT, GAMES, MUSICAL INSTRUMENTS, CAMERAS AND PHOTOS, BABIES, KIDS AND TOYS (U.S. CLS. 100, 101 AND 102).

JOHN WILKE, EXAMINING ATTORNEY

SN 85-345,336. HO-CHUNK NATION, BLACK RIVER FALLS, WI. FILED 6-14-2011.

HO-CHUNK DISTRIBUTION CENTER

THE MARK CONSISTS OF STANDARD CHARACTERS WITHOUT CLAIM TO ANY PARTICULAR FONT, STYLE, SIZE, OR COLOR.

NO CLAIM IS MADE TO THE EXCLUSIVE RIGHT TO USE "DISTRIBUTION CENTER", APART FROM THE MARK AS SHOWN.

FOR RETAIL AND WHOLESALE STORE SERVICES FEATURING A WIDE VARIETY OF CONSUMER GOODS OF OTHERS (U.S. CLS. 100, 101 AND 102).

FIRST USE 7-1-2003; IN COMMERCE 7-1-2003.

KATHLEEN M. VANSTON, EXAMINING ATTORNEY

CLASS 36—INSURANCE AND FINANCIAL

SN 76-704,269. HSBC FINANCE CORPORATION, METTAWA, IL. FILED 8-25-2010.

HYPERCOLOR

THE MARK CONSISTS OF STANDARD CHARACTERS WITHOUT CLAIM TO ANY PARTICULAR FONT, STYLE, SIZE, OR COLOR.

FOR BANKING AND CREDIT CARD SERVICES (U.S. CLS. 100, 101 AND 102).

FIRST USE 9-30-2005; IN COMMERCE 9-30-2005.

BERNICE MIDDLETON, EXAMINING ATTORNEY

SN 76-704,400. C.O.D. FRIENDLY, INC., CARROLLTON, TX. FILED 9-8-2010.

C.O.D. FRIENDLY

THE MARK CONSISTS OF STANDARD CHARACTERS WITHOUT CLAIM TO ANY PARTICULAR FONT, STYLE, SIZE, OR COLOR.

NO CLAIM IS MADE TO THE EXCLUSIVE RIGHT TO USE "C.O.D.", APART FROM THE MARK AS SHOWN.

FOR FACTORING SERVICES, NAMELY, ACCOUNTS RECEIVABLES FINANCING SERVICES (U.S. CLS. 100, 101 AND 102).

FIRST USE 7-0-2006; IN COMMERCE 7-0-2006.

CHARISMA HAMPTON, EXAMINING ATTORNEY

SN 76-704,401. C.O.D. FRIENDLY, INC., CARROLLTON, TX. FILED 9-8-2010.



NO CLAIM IS MADE TO THE EXCLUSIVE RIGHT TO USE "C.O.D.", APART FROM THE MARK AS SHOWN.

THE MARK CONSISTS OF THE TERMS "C.O.D." AND "FRIENDLY" WITH THE TERM "FRIENDLY" BEING ENCOMPASSED BY THE DESIGN OF A CONCENTRIC CIRCLE. THE DESIGN OF A CURVED ARROW IS LOCATED TO THE RIGHT OF THE CONCENTRIC CIRCLE DESIGN, WHERE THE POINT OF THE ARROW IS FEATURED INSIDE THE CIRCLE ADJACENT TO THE "Y" IN THE WORD "FRIENDLY" AND THE OTHER END IS LOCATED TO THE RIGHT AND OUTSIDE OF THE CONCENTRIC CIRCLE.

FOR FACTORING SERVICES, NAMELY, ACCOUNTS RECEIVABLES FINANCING SERVICES (U.S. CLS. 100, 101 AND 102).

FIRST USE 1-0-2010; IN COMMERCE 1-0-2010.

CHARISMA HAMPTON, EXAMINING ATTORNEY

CLASS 36—(Continued).

SN 77-873,987. ALTA EQUIPMENT COMPANY, INC., WIXOM, MI. FILED 11-17-2009.

CLASS 36—(Continued).

SN 78-350,718. STERLING NATIONAL BANK, NEW YORK, NY. FILED 1-12-2004.

Alta Financial Services



THE MARK CONSISTS OF STANDARD CHARACTERS WITHOUT CLAIM TO ANY PARTICULAR FONT, STYLE, SIZE, OR COLOR.

SUBJECT TO CONCURRENT USE PROCEEDING WITH REG. NO. 3662246. APPLICANT CLAIMS EXCLUSIVE RIGHT TO USE THE MARK IN THE AREA COMPRISING THE STATES OF ALABAMA, ARKANSAS, CONNECTICUT, DELAWARE, FLORIDA, GEORGIA, ILLINOIS, IOWA, KANSAS, KENTUCKY, LOUISIANA, MAINE, MARYLAND, MASSACHUSETTS, MICHIGAN, MINNESOTA, MISSISSIPPI, MISSOURI, NEBRASKA, NEW HAMPSHIRE, NEW JERSEY, NEW YORK, NORTH CAROLINA, NORTH DAKOTA, OHIO, OKLAHOMA, PENNSYLVANIA, RHODE ISLAND, SOUTH CAROLINA, SOUTH DAKOTA, TENNESSEE, VERMONT, VIRGINIA, WEST VIRGINIA AND WISCONSIN.

OWNER OF U.S. REG. NOS. 2,598,846 AND 2,705,077.

NO CLAIM IS MADE TO THE EXCLUSIVE RIGHT TO USE "FINANCIAL SERVICES", APART FROM THE MARK AS SHOWN.

THE ENGLISH TRANSLATION OF "ALTA" IN THE MARK IS "HIGH".

FOR FACILITATING AND ARRANGING FOR THE FINANCING OF LIFT TRUCKS AND PARTS, MATERIALS HANDLING EQUIPMENT AND OTHER CONSTRUCTION EQUIPMENT (U.S. CLS. 100, 101 AND 102).

FIRST USE 11-1-2010; IN COMMERCE 11-1-2010.

CHRISTOPHER BUONGIORNO, EXAMINING ATTORNEY

NO CLAIM IS MADE TO THE EXCLUSIVE RIGHT TO USE "CAPITAL FUNDING", APART FROM THE MARK AS SHOWN.

FOR BANKING AND FINANCIAL SERVICES, NAMELY, THE PURCHASE OF ACCOUNTS RECEIVABLE, FINANCIAL MANAGEMENT AND FINANCING LOANS SECURED BY ACCOUNTS RECEIVABLE OR FACTORED BALANCES AS THE PRODUCT OF SUCH RECEIVABLES (U.S. CLS. 100, 101 AND 102).

CHRISTINE MARTIN, EXAMINING ATTORNEY

SN 77-941,114. THE NASDAQ OMX GROUP, INC., NEW YORK, NY. FILED 2-22-2010.

SN 79-088,186. CELISTICS IP S.A.R.L., LUXEMBOURG, FILED 9-13-2010.

DREAM IT. DO IT.

movilway

THE MARK CONSISTS OF STANDARD CHARACTERS WITHOUT CLAIM TO ANY PARTICULAR FONT, STYLE, SIZE, OR COLOR.

FOR FINANCIAL SERVICES, NAMELY, CONDUCTING A SECURITIES EXCHANGE; COLLECTING AND PROVIDING FINANCIAL INFORMATION IN THE NATURE OF SECURITIES MARKET QUOTATIONS, SECURITIES MARKET TRANSACTIONS, AND FINANCIAL INDEX VALUES; LISTING OF SECURITIES AND SECURITIES DERIVATIVES FOR QUOTATION AND TRADING (U.S. CLS. 100, 101 AND 102).

ALEX KEAM, EXAMINING ATTORNEY

PRIORITY DATE OF 3-24-2010 IS CLAIMED.

OWNER OF INTERNATIONAL REGISTRATION 1053456 DATED 9-13-2010, EXPIRES 9-13-2020.

THE ENGLISH TRANSLATION OF "MOVIL" IN THE MARK IS "MOBILE".

FOR FINANCIAL SERVICES, NAMELY, PROVIDING ELECTRONIC PROCESSING OF ELECTRONIC FUNDS TRANSFERS AND ELECTRONIC PAYMENTS (U.S. CLS. 100, 101 AND 102).

KAREN BRACEY, EXAMINING ATTORNEY

CLASS 36—(Continued).

SN 79-089,249. PIERRE-HENRI MARIE FLAMAND, LONDON SW3 6RS, UNITED KINGDOM, FILED 10-19-2010.

EDOMA

THE MARK CONSISTS OF STANDARD CHARACTERS WITHOUT CLAIM TO ANY PARTICULAR FONT, STYLE, SIZE, OR COLOR.

PRIORITY DATE OF 4-27-2010 IS CLAIMED.

OWNER OF INTERNATIONAL REGISTRATION 1056401 DATED 10-19-2010, EXPIRES 10-19-2020.

THE WORDING "EDOMA" HAS NO MEANING IN A FOREIGN LANGUAGE.

FOR FINANCIAL AND MONETARY AFFAIRS, NAMELY, HEDGE FUND MANAGEMENT SERVICES, HEDGE FUND INVESTMENT SERVICES, PROVISION OF FINANCIAL INFORMATION, RESEARCH AND ANALYSIS, FINANCIAL ADVISORY AND CONSULTANCY SERVICES, FINANCIAL DUE DILIGENCE, FINANCIAL CONSULTING AND ADVISING IN THE FIELD OF MERGERS AND ACQUISITIONS, VENTURE CAPITAL ADVISORY SERVICES, MANAGEMENT AND BROKERAGE IN THE FIELDS OF STOCKS, BONDS, OPTIONS, COMMODITIES, FUTURES AND OTHER SECURITIES, FINANCIAL INVESTMENT ANALYSIS AND STOCK RESEARCH; FINANCIAL SERVICES, NAMELY, INVESTMENT ADVICE, INVESTMENT MANAGEMENT, INVESTMENT CONSULTATION AND INVESTMENT OF FUNDS FOR OTHERS, INCLUDING PRIVATE AND PUBLIC EQUITY AND DEBT INVESTMENT SERVICES; MANAGEMENT OF CAPITAL INVESTMENT FUNDS, MANAGEMENT OF PRIVATE EQUITY FUNDS (U.S. CLS. 100, 101 AND 102).

WARREN L. OLANDRIA, EXAMINING ATTORNEY

SN 85-030,114. HELIX FUNDS, LLC, CHICAGO, IL. FILED 5-4-2010.

NO CLAIM IS MADE TO THE EXCLUSIVE RIGHT TO USE "FUNDS", APART FROM THE MARK AS SHOWN.

THE MARK CONSISTS OF THE LETTER "H" ENCLOSED WITHIN A BOX LOCATED TO THE LEFT OF THE WORDS "HELIX", WHICH IS DISPLAYED ON TOP THE WORD "FUNDS".

FOR MANAGING REAL ESTATE INVESTMENTS; REAL ESTATE ASSET MANAGEMENT SERVICES (U.S. CLS. 100, 101 AND 102).

FIRST USE 4-7-2005; IN COMMERCE 4-7-2005.

JESSICA A. POWERS, EXAMINING ATTORNEY

CLASS 36—(Continued).

SN 85-048,407. AZEROS HEALTHCARE, LLC, WILLIAMSVILLE, NY. FILED 5-26-2010.

AZEROS

THE MARK CONSISTS OF STANDARD CHARACTERS WITHOUT CLAIM TO ANY PARTICULAR FONT, STYLE, SIZE, OR COLOR.

FOR BENEFITS ADMINISTRATION, NAMELY, ADMINISTRATION OF EMPLOYEE BENEFIT PLANS CONCERNING INSURANCE AND FINANCE; AND INSURANCE BROKERAGE SERVICES TO SELF-FUNDED AND INSURED PLANS (U.S. CLS. 100, 101 AND 102).

FIRST USE 5-1-2006; IN COMMERCE 5-1-2006.

RAMONA ORTIGA, EXAMINING ATTORNEY

SN 85-100,483. OWNERS ADVANTAGE, LLC, AKA OWNERS.COM, SAN FRANCISCO, CA. FILED 8-4-2010.

owners.com

THE MARK CONSISTS OF STANDARD CHARACTERS WITHOUT CLAIM TO ANY PARTICULAR FONT, STYLE, SIZE, OR COLOR.

SEC. 2(F).

FOR COMMERCIAL SERVICE, NAMELY, PROVIDING INFORMATION IN THE FIELD OF REAL ESTATE CONCERNING MORTGAGE LOANS, PROPERTY VALUES, HOME BUYING, HOME SELLING, AND FOR-SALE BY OWNER REAL ESTATE TRANSACTIONS (U.S. CLS. 100, 101 AND 102).

FIRST USE 5-7-1996; IN COMMERCE 5-7-1996.

AMY KERTGATE, EXAMINING ATTORNEY

SN 85-104,319. TEXAS DOW EMPLOYEES CREDIT UNION, AKA TDECU, LAKE JACKSON, TX. FILED 8-10-2010.

TDECU

THE MARK CONSISTS OF STANDARD CHARACTERS WITHOUT CLAIM TO ANY PARTICULAR FONT, STYLE, SIZE, OR COLOR.

OWNER OF U.S. REG. NOS. 2,336,122 AND 2,620,609.

FOR FINANCIAL SERVICES, NAMELY, BANKING SERVICES, FINANCIAL PLANNING SERVICES, COMMERCIAL LENDING SERVICES, MORTGAGE LENDING SERVICES, RETIREMENT PLANNING, INVESTMENT BROKERAGE SERVICES, INSURANCE BROKERAGE SERVICES, FINANCIAL INFORMATION AND ADVISORY SERVICES (U.S. CLS. 100, 101 AND 102).

FIRST USE 12-31-1999; IN COMMERCE 12-31-1999.

KHANH LE, EXAMINING ATTORNEY

CLASS 36—(Continued).

SN 85-104,898. EDMUNDS.COM, INC., SANTA MONICA, CA. FILED 8-11-2010.

TRUE COST TO OWN

THE MARK CONSISTS OF STANDARD CHARACTERS WITHOUT CLAIM TO ANY PARTICULAR FONT, STYLE, SIZE, OR COLOR.

OWNER OF U.S. REG. NO. 3,518,664.
SEC. 2(F).

FOR COMPUTER SERVICES, NAMELY, PROVIDING AN ONLINE, INTERACTIVE DATABASE WHICH CALCULATES THE OWNERSHIP COSTS OF A VEHICLE OVER A SPECIFIED TIME PERIOD (U.S. CLS. 100, 101 AND 102).

FIRST USE 5-1-2002; IN COMMERCE 5-1-2002.
JESSICA FATHY, EXAMINING ATTORNEY

SN 85-105,031. EDMUNDS.COM, INC., SANTA MONICA, CA. FILED 8-11-2010.

TRUE COST OF INCENTIVES

THE MARK CONSISTS OF STANDARD CHARACTERS WITHOUT CLAIM TO ANY PARTICULAR FONT, STYLE, SIZE, OR COLOR.

SEC. 2(F).

FOR PROVIDING ONLINE INFORMATION IN THE NATURE OF AN ANALYSIS OF THE AVERAGE COST PER UNIT OF AUTOMOBILE MANUFACTURER INCENTIVES PROGRAMS FOR PASSENGER VEHICLES (U.S. CLS. 100, 101 AND 102).

FIRST USE 3-3-2003; IN COMMERCE 3-3-2003.
JESSICA FATHY, EXAMINING ATTORNEY

SN 85-111,362. EFG BANK EUROPEAN FINANCIAL GROUP SA, GENEVE 2, SWITZERLAND, FILED 8-19-2010.

EFG CAPITAL ASSET MANAGEMENT

THE MARK CONSISTS OF STANDARD CHARACTERS WITHOUT CLAIM TO ANY PARTICULAR FONT, STYLE, SIZE, OR COLOR.

OWNER OF U.S. REG. NOS. 2,554,449, 3,656,866 AND OTHERS.

NO CLAIM IS MADE TO THE EXCLUSIVE RIGHT TO USE "CAPITAL ASSET MANAGEMENT", APART FROM THE MARK AS SHOWN.

FOR FINANCIAL SERVICES, NAMELY, WEALTH MANAGEMENT AND FINANCIAL ADVISORY SERVICES TO HIGH NET WORTH INDIVIDUALS (U.S. CLS. 100, 101 AND 102).

BARBARA A. GOLD, EXAMINING ATTORNEY

CLASS 36—(Continued).

SN 85-113,057. CHILD CARE SERVICES ASSOCIATION, INC., CHAPEL HILL, NC. FILED 8-22-2010.

AFTERSCHOOL WAGES

THE MARK CONSISTS OF STANDARD CHARACTERS WITHOUT CLAIM TO ANY PARTICULAR FONT, STYLE, SIZE, OR COLOR.

OWNER OF U.S. REG. NO. 2,469,533.

NO CLAIM IS MADE TO THE EXCLUSIVE RIGHT TO USE "AFTERSCHOOL WAGES", APART FROM THE MARK AS SHOWN.

FOR FINANCIAL ADMINISTRATION OF A GRANT PROGRAM TO IMPROVE AFTERSCHOOL SERVICES, NAMELY, PROVIDING FINANCIAL GRANTS IN THE FORM OF SALARY SUPPLEMENTS FOR AFTERSCHOOL PROGRAM PRACTITIONERS (U.S. CLS. 100, 101 AND 102).

FIRST USE 11-20-2009; IN COMMERCE 11-20-2009.
MORGAN WYNNE, EXAMINING ATTORNEY

SN 85-113,968. COMMITTEE ON ADVANCED TUITION PAYMENT, OLYMPIA, WA. FILED 8-23-2010.



OWNER OF U.S. REG. NO. 2,419,736.

NO CLAIM IS MADE TO THE EXCLUSIVE RIGHT TO USE "GUARANTEED EDUCATION TUITION", APART FROM THE MARK AS SHOWN.

THE MARK CONSISTS OF A DEPICTION OF A PERSON IN A GRADUATION CAP AND GOWN RUNNING WITH A DIPLOMA, AND THE WORD "GET" APPEARING TO THE RIGHT OF THIS DESIGN, AND THE WORDING "GUARANTEED EDUCATION TUITION," AND "BUY TOMORROW'S COLLEGE TUITION TODAY" APPEARING BENEATH THE AFOREMENTIONED WORDING AND DESIGN.

FOR PRE-PAID EDUCATIONAL FINANCIAL SERVICES, NAMELY, ALLOWING PURCHASERS TO MAKE ADVANCE PAYMENTS TOWARDS FUTURE CONTINUING EDUCATION, AND PROVIDING INFORMATION RELATING TO EDUCATION FINANCING (U.S. CLS. 100, 101 AND 102).

FIRST USE 1-1-2008; IN COMMERCE 1-1-2008.
KEVIN CORWIN, EXAMINING ATTORNEY

CLASS 36—(Continued).

SN 85-113,971. COMMITTEE ON ADVANCED TUITION PAYMENT, OLYMPIA, WA. FILED 8-23-2010.



OWNER OF U.S. REG. NO. 2,419,736.

NO CLAIM IS MADE TO THE EXCLUSIVE RIGHT TO USE "GUARANTEED EDUCATION TUITION", APART FROM THE MARK AS SHOWN.

THE MARK CONSISTS OF A DEPICTION OF A PERSON IN A GRADUATION CAP AND GOWN RUNNING WITH A DIPLOMA WITH THE WORDS "GET" TO THE RIGHT AND THE WORDS "GUARANTEED EDUCATION TUITION" BELOW.

FOR PRE-PAID EDUCATIONAL FINANCIAL SERVICES, NAMELY, ALLOWING PURCHASERS TO MAKE ADVANCE PAYMENTS TOWARDS FUTURE CONTINUING EDUCATION, AND PROVIDING INFORMATION RELATING TO EDUCATION FINANCING (U.S. CLS. 100, 101 AND 102).

FIRST USE 1-1-2008; IN COMMERCE 1-1-2008.
KEVIN CORWIN, EXAMINING ATTORNEY

SN 85-116,128. CAIDAN MANAGEMENT COMPANY, LLC, DETROIT, MI. FILED 8-26-2010.



NO CLAIM IS MADE TO THE EXCLUSIVE RIGHT TO USE "HEALTH PLAN OF MICHIGAN" AND THE OUTLINE OF THE SHAPE OF THE STATE OF MICHIGAN, APART FROM THE MARK AS SHOWN.

THE COLOR(S) GOLD AND BLACK IS/ARE CLAIMED AS A FEATURE OF THE MARK.

THE MARK CONSISTS OF A GOLD SHADED, BLACK OUTLINED, MAP REPRESENTING THE STATE OF MICHIGAN. THE BLACK STYLIZED LETTERS "H" "P" AND "M" ARE TO THE LEFT OF THE MAP WITH THE LETTER "M" BELOW "H" AND "P", AND THE LETTER "P" SUPERIMPOSED OVER A SECTION OF THE MAP. CENTERED BENEATH THE LETTERS AND MAP ARE THE BLACK STYLIZED WORDS "HEALTH PLAN" WITH THE BLACK STYLIZED WORDS "OF MICHIGAN" UNDERNEATH.

FOR ADMINISTRATION OF PRE-PAID HEALTH CARE PLANS (U.S. CLS. 100, 101 AND 102).

FIRST USE 9-0-1995; IN COMMERCE 9-0-1995.
CARYN GLASSER, EXAMINING ATTORNEY

CLASS 36—(Continued).

SN 85-116,566. CAIDAN MANAGEMENT COMPANY, LLC, DETROIT, MI. FILED 8-26-2010.



NO CLAIM IS MADE TO THE EXCLUSIVE RIGHT TO USE "HEALTH PLAN OF MICHIGAN" OR THE SHAPE OF THE OUTLINE OF THE STATE OF MICHIGAN, APART FROM THE MARK AS SHOWN.

THE COLOR(S) GOLD, WHITE AND BLACK IS/ARE CLAIMED AS A FEATURE OF THE MARK.

THE MARK CONSISTS OF A WHITE CIRCLE, BORDERED BY A GOLDEN SHADED, BLACK OUTLINED, BAND. WITHIN THE CIRCLE IS A GOLDEN SHADED MAP OF THE STATE OF MICHIGAN OUTLINED IN BLACK. THE BLACK STYLIZED LETTERS "H" "P" AND "M" ARE TO THE LEFT OF THE MAP WITH THE LETTER "M" BELOW "H" AND "P", AND THE LETTER "P" SUPERIMPOSED OVER A SECTION OF THE MAP. THE BLACK STYLIZED WORDS "HEALTH PLAN" ARE CENTERED ON THE BOTTOM OF THE CIRCLE ABOVE THE BLACK STYLIZED WORDS "OF MICHIGAN".

FOR ADMINISTRATION OF PRE-PAID HEALTH CARE PLANS (U.S. CLS. 100, 101 AND 102).

FIRST USE 9-0-1995; IN COMMERCE 9-0-1995.
CARYN GLASSER, EXAMINING ATTORNEY

SN 85-121,101. UNITED STATES GENERAL SERVICES ADMINISTRATION, WASHINGTON, DC. FILED 9-1-2010.

GSA SmartPay

THE MARK CONSISTS OF STANDARD CHARACTERS WITHOUT CLAIM TO ANY PARTICULAR FONT, STYLE, SIZE, OR COLOR.

OWNER OF U.S. REG. NO. 2,384,615.

NO CLAIM IS MADE TO THE EXCLUSIVE RIGHT TO USE "GSA", APART FROM THE MARK AS SHOWN.

FOR CREDIT CARD AND PAYMENT CARD SERVICES (U.S. CLS. 100, 101 AND 102).

FIRST USE 9-12-2000; IN COMMERCE 9-12-2000.
JESSICA FATHY, EXAMINING ATTORNEY

CLASS 36—(Continued).

SN 85-121,940. US GENERAL SERVICES ADMINISTRATION, FAS, WASHINGTON, DC. FILED 9-2-2010.



OWNER OF U.S. REG. NOS. 2,384,615 AND 2,604,877.
NO CLAIM IS MADE TO THE EXCLUSIVE RIGHT TO USE "GSA", APART FROM THE MARK AS SHOWN.
THE MARK CONSISTS OF A SHADED SQUARE FEATURING THE LETTERS "GSA", THE LETTER "A" INCLUDES A STAR DESIGN. TO THE RIGHT IS THE WORDING "SMARTPAY".
FOR CREDIT CARD AND PAYMENT CARD SERVICES (U.S. CLS. 100, 101 AND 102).
FIRST USE 8-10-2010; IN COMMERCE 8-10-2010.
JESSICA FATHY, EXAMINING ATTORNEY

SN 85-123,372. FERNANDEZ, JORGE LUIS, MIAMI, FL. FILED 9-4-2010.

UNCLE SAMS PAWN

THE MARK CONSISTS OF STANDARD CHARACTERS WITHOUT CLAIM TO ANY PARTICULAR FONT, STYLE, SIZE, OR COLOR.
NO CLAIM IS MADE TO THE EXCLUSIVE RIGHT TO USE "PAWN", APART FROM THE MARK AS SHOWN.
FOR PAWN BROKERAGE (U.S. CLS. 100, 101 AND 102).
MAUREEN DALL, EXAMINING ATTORNEY

SN 85-123,404. WASHINGTON TRUST BANK, SPOKANE, WA. FILED 9-5-2010.

WTB ELECTRONIC FILE DEPOSIT

THE MARK CONSISTS OF STANDARD CHARACTERS WITHOUT CLAIM TO ANY PARTICULAR FONT, STYLE, SIZE, OR COLOR.
OWNER OF U.S. REG. NOS. 3,394,548 AND 3,781,572.
NO CLAIM IS MADE TO THE EXCLUSIVE RIGHT TO USE "ELECTRONIC FILE DEPOSIT", APART FROM THE MARK AS SHOWN.
FOR BANKING SERVICES; BANKING DEPOSIT PROCESSING SERVICES (U.S. CLS. 100, 101 AND 102).
JESSICA A. POWERS, EXAMINING ATTORNEY

CLASS 36—(Continued).

SN 85-124,880. SYVEN GLOBAL SERVICES, INC., NEW YORK, NY. FILED 9-8-2010.

SYVEN

THE MARK CONSISTS OF STANDARD CHARACTERS WITHOUT CLAIM TO ANY PARTICULAR FONT, STYLE, SIZE, OR COLOR.
FOR FINANCIAL CONSULTING; FINANCIAL INVESTMENT ADVISORY; FINANCIAL ANALYSIS AND RESEARCH SERVICES (U.S. CLS. 100, 101 AND 102).
FIRST USE 1-1-1998; IN COMMERCE 2-28-2008.
KHANH LE, EXAMINING ATTORNEY

SN 85-126,760. ROSENDO, GUERRA, LAREDO, TX. FILED 9-10-2010.

LUOS MASTER OFFICES

THE MARK CONSISTS OF STANDARD CHARACTERS WITHOUT CLAIM TO ANY PARTICULAR FONT, STYLE, SIZE, OR COLOR.
NO CLAIM IS MADE TO THE EXCLUSIVE RIGHT TO USE "MASTER OFFICES", APART FROM THE MARK AS SHOWN.
FOR LEASING OF OFFICE SPACE (U.S. CLS. 100, 101 AND 102).
JESSICA A. POWERS, EXAMINING ATTORNEY

SN 85-130,479. UTAH COMMUNITY FEDERAL CREDIT UNION, DBA UCCU, UTAH COMMUNITY CREDIT UNION, PROVO, UT. FILED 9-15-2010.

UTAH COMMUNITY FEDERAL CREDIT UNION

THE MARK CONSISTS OF STANDARD CHARACTERS WITHOUT CLAIM TO ANY PARTICULAR FONT, STYLE, SIZE, OR COLOR.
OWNER OF U.S. REG. NO. 2,941,156.
NO CLAIM IS MADE TO THE EXCLUSIVE RIGHT TO USE "COMMUNITY FEDERAL CREDIT UNION", APART FROM THE MARK AS SHOWN.
SEC. 2(F).
FOR BANKING AND FINANCING SERVICES; BANKING SERVICES; ELECTRONIC BANKING VIA A GLOBAL COMPUTER NETWORK; INVESTMENT BANKING SERVICES; MORTGAGE BANKING; ON-LINE BANKING SERVICES; TELEPHONE BANKING SERVICES (U.S. CLS. 100, 101 AND 102).
FIRST USE 2-28-2000; IN COMMERCE 2-28-2000.
CAROLYN CATALDO, EXAMINING ATTORNEY

CLASS 36—(Continued).

SN 85-132,016. THE SHINE FOUNDATION, NORMAN, OK. FILED 9-17-2010.

RAINBOW TOWN

THE MARK CONSISTS OF STANDARD CHARACTERS WITHOUT CLAIM TO ANY PARTICULAR FONT, STYLE, SIZE, OR COLOR.
FOR ORGANIZING AND CONDUCTING FUNDRAISING EVENTS TO RAISE MONEY FOR ORPHANAGES (U.S. CLS. 100, 101 AND 102).
FIRST USE 11-20-2009; IN COMMERCE 11-20-2009.
SUNG IN, EXAMINING ATTORNEY

SN 85-135,224. DIMENSIONAL FUND ADVISORS LP, AUSTIN, TX. FILED 9-22-2010.

DIMENSIONAL MANAGED DC

THE MARK CONSISTS OF STANDARD CHARACTERS WITHOUT CLAIM TO ANY PARTICULAR FONT, STYLE, SIZE, OR COLOR.
OWNER OF U.S. REG. NOS. 1,746,066, 2,985,014 AND OTHERS.
NO CLAIM IS MADE TO THE EXCLUSIVE RIGHT TO USE "MANAGED DC", APART FROM THE MARK AS SHOWN.
FOR ADMINISTRATION OF EMPLOYEE PENSION PLANS; FINANCIAL ADMINISTRATION OF RETIREMENT PLANS; INVESTMENT ADVISORY SERVICES; INVESTMENT CONSULTATION; INVESTMENT MANAGEMENT; INVESTMENT OF FUNDS FOR OTHERS (U.S. CLS. 100, 101 AND 102).
FIRST USE 5-26-2010; IN COMMERCE 5-26-2010.
ELLEN PERKINS, EXAMINING ATTORNEY

CLASS 36—(Continued).

SN 85-136,226. FARMERS GROUP, INC., LOS ANGELES, CA. FILED 9-23-2010.

WE ARE INSURANCE. WE ARE FARMERS.

THE MARK CONSISTS OF STANDARD CHARACTERS WITHOUT CLAIM TO ANY PARTICULAR FONT, STYLE, SIZE, OR COLOR.
NO CLAIM IS MADE TO THE EXCLUSIVE RIGHT TO USE "INSURANCE", APART FROM THE MARK AS SHOWN.
FOR INSURANCE UNDERWRITING SERVICES IN THE FIELD OF PROPERTY, CASUALTY, LIFE, AUTOMOBILE, BOAT, FARM AND RANCH, FLOOD, WORKERS COMPENSATION, RENTERS, TOWNHOUSE, CONDOMINIUM, AND HOMEOWNERS; INSURANCE CLAIMS PROCESSING, INSURANCE ADMINISTRATION, AND INSURANCE AGENCY SERVICES; PROVIDING INFORMATION IN INSURANCE MATTERS (U.S. CLS. 100, 101 AND 102).
SHAUNIA CARLYLE, EXAMINING ATTORNEY

SN 85-144,597. TRISKELE FOUNDATION INC., LAKEWOOD, CO. FILED 10-4-2010.

Triskele Foundation

THE MARK CONSISTS OF STANDARD CHARACTERS WITHOUT CLAIM TO ANY PARTICULAR FONT, STYLE, SIZE, OR COLOR.
NO CLAIM IS MADE TO THE EXCLUSIVE RIGHT TO USE "FOUNDATION", APART FROM THE MARK AS SHOWN.
FOR CHARITABLE FOUNDATION SERVICES, NAMELY, PROVIDING FUNDRAISING ACTIVITIES, FUNDING, SCHOLARSHIPS AND/OR FINANCIAL ASSISTANCE FOR GENERAL EDUCATIONAL DEVELOPMENT EDUCATION AND TESTING.; CHARITABLE FOUNDATION SERVICES, NAMELY, PROVIDING FUNDRAISING ACTIVITIES, SUPPLEMENTAL FUNDING, CAPITAL IMPROVEMENT FUNDING, SCHOLARSHIPS AND FINANCIAL ASSISTANCE FOR PROGRAMS AND SERVICES OF OTHERS; CHARITABLE FUNDRAISING SERVICES BY MEANS OF SELLING SILVER PENDANTS TO RAISE FUNDS FOR GENERAL EDUCATIONAL DEVELOPMENT EDUCATION AND TESTING; CHARITABLE SERVICES, NAMELY, GRANTING FUNDS TO SCHOOLS (U.S. CLS. 100, 101 AND 102).
FIRST USE 5-27-2010; IN COMMERCE 8-1-2010.
MARTHA FROMM, EXAMINING ATTORNEY

CLASS 36—(Continued).

SN 85-144,947. BATS GLOBAL MARKETS, INC., LENEXA, KS. FILED 10-5-2010.

BATS Options

THE MARK CONSISTS OF STANDARD CHARACTERS WITHOUT CLAIM TO ANY PARTICULAR FONT, STYLE, SIZE, OR COLOR.

OWNER OF U.S. REG. NOS. 3,288,792, 3,818,008 AND 3,818,024.

NO CLAIM IS MADE TO THE EXCLUSIVE RIGHT TO USE "OPTIONS", APART FROM THE MARK AS SHOWN.

FOR FINANCIAL SERVICES, NAMELY, CONDUCTING A SECURITIES AND DERIVATIVES EXCHANGE (U.S. CLS. 100, 101 AND 102).

FIRST USE 2-1-2009; IN COMMERCE 7-8-2009.

JULIE GUTTADAURO, EXAMINING ATTORNEY

CLASS 36—(Continued).

SN 85-176,570. PENNSYLVANIA BREAST CANCER COALITION, EPHRATA, PA. FILED 11-15-2010.

TAKE A SWING AGAINST BREAST CANCER

THE MARK CONSISTS OF STANDARD CHARACTERS WITHOUT CLAIM TO ANY PARTICULAR FONT, STYLE, SIZE, OR COLOR.

NO CLAIM IS MADE TO THE EXCLUSIVE RIGHT TO USE "BREAST CANCER", APART FROM THE MARK AS SHOWN.

FOR CHARITABLE FUNDRAISING SERVICES BY MEANS OF ORGANIZING AND CONDUCTING SPECIAL EVENTS (U.S. CLS. 100, 101 AND 102).

FIRST USE 11-1-2007; IN COMMERCE 1-15-2008.

TRACY CROSS, EXAMINING ATTORNEY

SN 85-186,019. STONER, TIMOTHY D, ZIONSVILLE, IN. AND STONER, TIFFANY P, ZIONSVILLE, IN. FILED 11-29-2010.

FamilyPrint

THE MARK CONSISTS OF STANDARD CHARACTERS WITHOUT CLAIM TO ANY PARTICULAR FONT, STYLE, SIZE, OR COLOR.

FOR CHARITABLE FUNDRAISING (U.S. CLS. 100, 101 AND 102).

FIRST USE 10-9-2009; IN COMMERCE 10-9-2009.

BARBARA BROWN, EXAMINING ATTORNEY

SN 85-144,966. BATS GLOBAL MARKETS, INC., LENEXA, KS. FILED 10-5-2010.

BATS Global Markets

THE MARK CONSISTS OF STANDARD CHARACTERS WITHOUT CLAIM TO ANY PARTICULAR FONT, STYLE, SIZE, OR COLOR.

OWNER OF U.S. REG. NOS. 3,288,792, 3,818,024 AND OTHERS.

NO CLAIM IS MADE TO THE EXCLUSIVE RIGHT TO USE "GLOBAL MARKETS", APART FROM THE MARK AS SHOWN.

FOR FINANCIAL ADMINISTRATION OF STOCK EXCHANGE TRADING OF SHARES AND OTHER FINANCIAL SECURITIES IN FINANCIAL MARKETS; FINANCIAL SECURITIES EXCHANGE SERVICES; ORGANIZATION OF ONLINE STOCK EXCHANGES FOR THE BENEFIT OF THE TRADE OF STOCKS AND OTHER FINANCIAL SECURITIES; SECURITIES TRADE EXECUTION SERVICES; SECURITIES TRADING SERVICES FOR OTHERS VIA THE INTERNET AND THE GLOBAL INFORMATION NETWORK (U.S. CLS. 100, 101 AND 102).

FIRST USE 11-1-2008; IN COMMERCE 1-30-2009.

JULIE GUTTADAURO, EXAMINING ATTORNEY

SN 85-190,451. PLANET FINANCIAL GROUP, LLC, ALGONQUIN, IL. FILED 12-3-2010.

PLANET FINANCIAL

THE MARK CONSISTS OF STANDARD CHARACTERS WITHOUT CLAIM TO ANY PARTICULAR FONT, STYLE, SIZE, OR COLOR.

NO CLAIM IS MADE TO THE EXCLUSIVE RIGHT TO USE "FINANCIAL", APART FROM THE MARK AS SHOWN.

FOR FINANCIAL SERVICES, NAMELY, THE ACQUISITION AND SALE OF FINANCIAL AND MORTGAGE RELATED ASSETS, THE ISSUANCE OF MORTGAGE BACKED SECURITIES AND THE ORIGINATION AND SERVICING OF CONSUMER AND COMMERCIAL LOANS, NAMELY, MORTGAGE LOANS (U.S. CLS. 100, 101 AND 102).

FIRST USE 5-30-2008; IN COMMERCE 5-30-2008.

JANET LEE, EXAMINING ATTORNEY

CLASS 36—(Continued).

SN 85-204,030. LOUISIANA MEDICAL MUTUAL INSURANCE COMPANY, METAIRIE, LA. FILED 12-22-2010.



THE MARK CONSISTS OF THE STYLIZED LETTERS "M" AND "I" WITH A FLOURISH ABOVE THE LETTER "I" AND THE WORD "COMMUNITY" INSIDE THE LETTER "I".

FOR CONSULTING SERVICES IN THE FIELD OF INSURANCE RISK MANAGEMENT (U.S. CLS. 100, 101 AND 102).

BRENDAN MCCAULEY, EXAMINING ATTORNEY

CLASS 36—(Continued).

SN 85-210,863. AGMOTION, INC., MINNEAPOLIS, MN. FILED 1-5-2011.

TBE CAPITAL

THE MARK CONSISTS OF STANDARD CHARACTERS WITHOUT CLAIM TO ANY PARTICULAR FONT, STYLE, SIZE, OR COLOR.

NO CLAIM IS MADE TO THE EXCLUSIVE RIGHT TO USE "CAPITAL", APART FROM THE MARK AS SHOWN.

FOR CAPITAL INVESTMENT SERVICES, NAMELY, PROVIDING FINANCIAL MANAGEMENT OF CLIENT ASSETS ON A DISCRETIONARY BASIS USING FUTURES AND OPTIONS (U.S. CLS. 100, 101 AND 102).

FIRST USE 6-0-2010; IN COMMERCE 6-0-2010.

WILLIAM ROSSMAN, EXAMINING ATTORNEY

SN 85-211,044. QATAR INVESTMENT AUTHORITY, DOHA, QATAR, FILED 1-5-2011.

SN 85-204,163. LOUISIANA MEDICAL MUTUAL INSURANCE COMPANY, METAIRIE, LA. FILED 12-22-2010.



THE MARK CONSISTS OF THE STYLIZED LETTERS "M" AND "I" WITH A FLOURISH ABOVE THE LETTER "I".

FOR CONSULTING SERVICES IN THE FIELD OF INSURANCE RISK MANAGEMENT (U.S. CLS. 100, 101 AND 102).

BRENDAN MCCAULEY, EXAMINING ATTORNEY



NO CLAIM IS MADE TO THE EXCLUSIVE RIGHT TO USE "QATAR INVESTMENT AUTHORITY" AND THE NON-LATIN CHARACTERS THAT TRANSLITERATE TO JEHAZ QATAR LELESTETHMAR, APART FROM THE MARK AS SHOWN.

THE COLOR(S) PURPLE IS/ARE CLAIMED AS A FEATURE OF THE MARK.

THE MARK CONSISTS OF THE LETTERS "QIA" CUT OUT OF A PURPLE SQUARE ALONG WITH A SERIES OF TWO PARALLEL LINES OF CIRCLES COVERING TWO AND A HALF SIDES OF THE SQUARE. TO THE RIGHT APPEARS THE WORDING "QATAR INVESTMENT AUTHORITY" IN PURPLE IN ENGLISH AND ARABIC. THE WHITE AREAS OF THE DRAWING INDICATE TRANSPARENCY AND ARE NOT INTENDED TO REPRESENT THE COLOR WHITE.

THE NON-LATIN CHARACTERS IN THE MARK TRANSLITERATE TO JEHAZ "QATAR" LELESTETHMAR AND THIS MEANS "QATAR INVESTMENT AUTHORITY" IN ENGLISH.

FOR EQUITY CAPITAL INVESTMENT; CAPITAL INVESTMENT CONSULTING; FINANCIAL CONSULTANCY; FINANCIAL MANAGEMENT; FINANCING SERVICES (U.S. CLS. 100, 101 AND 102).

CHRISIE B. KING, EXAMINING ATTORNEY

CLASS 36—(Continued).

SN 85-216,240. HARRIS NATIONAL ASSOCIATION, CHICAGO, IL. FILED 1-12-2011.

HARRIS PERSONAL SAVINGS

THE MARK CONSISTS OF STANDARD CHARACTERS WITHOUT CLAIM TO ANY PARTICULAR FONT, STYLE, SIZE, OR COLOR.

OWNER OF U.S. REG. NOS. 1,008,229, 2,891,231 AND OTHERS.

NO CLAIM IS MADE TO THE EXCLUSIVE RIGHT TO USE "PERSONAL SAVINGS", APART FROM THE MARK AS SHOWN.

SEC. 2(F) AS TO "HARRIS".
FOR BANKING SERVICES; SAVINGS ACCOUNT SERVICES (U.S. CLS. 100, 101 AND 102).
JASON TURNER, EXAMINING ATTORNEY

SN 85-216,261. HARRIS NATIONAL ASSOCIATION, CHICAGO, IL. FILED 1-12-2011.

HARRIS SELECT MONEY MARKET

THE MARK CONSISTS OF STANDARD CHARACTERS WITHOUT CLAIM TO ANY PARTICULAR FONT, STYLE, SIZE, OR COLOR.

NO CLAIM IS MADE TO THE EXCLUSIVE RIGHT TO USE "MONEY MARKET", APART FROM THE MARK AS SHOWN.

FOR BANKING SERVICES; MONEY MARKET ACCOUNT SERVICES; CHECKING ACCOUNT SERVICES (U.S. CLS. 100, 101 AND 102).
JASON TURNER, EXAMINING ATTORNEY

SN 85-224,699. A&E TELEVISION NETWORKS LLC, NEW YORK, NY. FILED 1-24-2011.

GIVE 150

THE MARK CONSISTS OF STANDARD CHARACTERS WITHOUT CLAIM TO ANY PARTICULAR FONT, STYLE, SIZE, OR COLOR.

NO CLAIM IS MADE TO THE EXCLUSIVE RIGHT TO USE "GIVE", APART FROM THE MARK AS SHOWN.

FOR CHARITABLE FUNDRAISING SERVICES; PHILANTHROPIC SERVICES, NAMELY, FINANCIAL ENDOWMENTS PRESERVATION OF CIVIL WAR MEMORABILIA AND LOCATIONS (U.S. CLS. 100, 101 AND 102).

FIRST USE 4-11-2011; IN COMMERCE 4-11-2011.
KHANH LE, EXAMINING ATTORNEY

CLASS 36—(Continued).

SN 85-230,819. RETAIL CAPITAL, LLC, BIRMINGHAM, MI. FILED 2-1-2011.

RETAIL CAPITAL

THE MARK CONSISTS OF STANDARD CHARACTERS WITHOUT CLAIM TO ANY PARTICULAR FONT, STYLE, SIZE, OR COLOR.

NO CLAIM IS MADE TO THE EXCLUSIVE RIGHT TO USE "CAPITAL", APART FROM THE MARK AS SHOWN.

FOR CASH ADVANCE SERVICES FOR BUSINESSES AND MERCHANTS (U.S. CLS. 100, 101 AND 102).
FIRST USE 6-7-2010; IN COMMERCE 11-16-2010.
JULIE GUTTADAURO, EXAMINING ATTORNEY

SN 85-231,150. RETAIL ROYALTY COMPANY, LAS VEGAS, NV. FILED 2-1-2011.



OWNER OF U.S. REG. NOS. 3,674,436, 3,819,784 AND OTHERS.

THE MARK CONSISTS OF A "BIRD" DESIGN.
FOR FINANCIAL, FINANCIALLY-RELATED, ELECTRONIC AND ONLINE-IMPLEMENTED FINANCIAL, AND CARD-IMPLEMENTED SERVICES, NAMELY, CHARGE CARD SERVICES, CREDIT CARD SERVICES, ELECTRONIC FUNDS TRANSFER SERVICES, ELECTRONIC CREDIT TRANSACTION SERVICES, POINT-OF-SALE AND POINT-OF-TRANSACTION ELECTRONIC PAYMENT SERVICES, NAMELY, CREDIT CARD TRANSACTION PROCESSING (U.S. CLS. 100, 101 AND 102).

FIRST USE 1-1-2010; IN COMMERCE 1-1-2010.
LINDA MICKLEBURGH, EXAMINING ATTORNEY

CLASS 36—(Continued).

SN 85-234,544. REALCOMP II LTD., FARMINGTON HILLS, MI. FILED 2-4-2011.



OWNER OF U.S. REG. NOS. 2,939,473 AND 3,404,731.
NO CLAIM IS MADE TO THE EXCLUSIVE RIGHT TO USE THE DEPICTION OF THE STATE OF MICHIGAN AND ".COM", APART FROM THE MARK AS SHOWN.

THE MARK CONSISTS OF THE WORDING "MOVE-INMICHIGAN.COM", SURROUNDING THE TERM "IN" IS THE OUTLINE OF A DETACHED HOUSE, TO THE LEFT OF THE WORDING IS A PICTORIAL DEPICTION OF THE STATE OF MICHIGAN.

FOR PROVIDING AN ON-LINE DATABASE WHICH FEATURES INFORMATION REGARDING REAL ESTATE LISTINGS FROM SUBSCRIBERS (U.S. CLS. 100, 101 AND 102).

FIRST USE 6-21-2010; IN COMMERCE 6-21-2010.
ALICIA COLLINS, EXAMINING ATTORNEY

SN 85-234,763. ADAM BIESK, LOS ANGELES, CA. FILED 2-4-2011.

ArtTransact

THE MARK CONSISTS OF STANDARD CHARACTERS WITHOUT CLAIM TO ANY PARTICULAR FONT, STYLE, SIZE, OR COLOR.

FOR ON-LINE ESCROW SERVICE FOR EXCHANGE OF SERVICES (U.S. CLS. 100, 101 AND 102).

FIRST USE 10-1-2010; IN COMMERCE 12-1-2010.
JULIE GUTTADAURO, EXAMINING ATTORNEY

SN 85-239,273. RANGER CAPITAL GROUP HOLDINGS, L.P., DALLAS, TX. FILED 2-10-2011.

ACTIVE BEAR

THE MARK CONSISTS OF STANDARD CHARACTERS WITHOUT CLAIM TO ANY PARTICULAR FONT, STYLE, SIZE, OR COLOR.

FOR FINANCIAL SERVICES, NAMELY, INVESTMENT MANAGEMENT SERVICES IN THE FIELD OF EXCHANGE-TRADED FUNDS, GLOBAL SECURITIES, INCLUDING STOCKS, OPTIONS AND COMMODITIES (U.S. CLS. 100, 101 AND 102).

LINDA ORNDORFF, EXAMINING ATTORNEY

CLASS 36—(Continued).

SN 85-243,449. THIRD COAST INSURANCE COMPANY, CHICAGO, IL. FILED 2-16-2011.

3CU

THE MARK CONSISTS OF STANDARD CHARACTERS WITHOUT CLAIM TO ANY PARTICULAR FONT, STYLE, SIZE, OR COLOR.

FOR SPECIALTY WORKERS COMPENSATION INSURANCE UNDERWRITING AND ADMINISTRATION SERVICES (U.S. CLS. 100, 101 AND 102).

FIRST USE 6-1-2010; IN COMMERCE 6-1-2010.
LIEF MARTIN, EXAMINING ATTORNEY

SN 85-246,141. MIKE GODIN, NIAGARA FALLS, ONTARIO, CANADA, FILED 2-18-2011.



NO CLAIM IS MADE TO THE EXCLUSIVE RIGHT TO USE "NO DEDUCTIBLE", APART FROM THE MARK AS SHOWN.

THE MARK CONSISTS OF THE WORDS "NO DEDUCTIBLE", A STAMP, AN OVAL SHAPED FIGURE LINE-CURVED.

FOR INSURANCE SERVICES, NAMELY, INSURANCE BROKERAGE SERVICES (U.S. CLS. 100, 101 AND 102).

CARYN GLASSER, EXAMINING ATTORNEY

SN 85-246,317. LOUISIANA HEALTH SERVICE AND INDEMNITY COMPANY, DBA BLUE CROSS AND BLUE SHIELD OF LOUISIANA, BATON ROUGE, LA. FILED 2-18-2011.

OUR HOME, LOUISIANA.

THE MARK CONSISTS OF STANDARD CHARACTERS WITHOUT CLAIM TO ANY PARTICULAR FONT, STYLE, SIZE, OR COLOR.

SEC. 2(F) AS TO "LOUISIANA".

FOR INSURANCE SERVICES, NAMELY, UNDERWRITING, ISSUING AND ADMINISTRATION OF HEALTH AND ACCIDENT INSURANCE (U.S. CLS. 100, 101 AND 102).

FIRST USE 10-31-2005; IN COMMERCE 10-31-2005.
DAVID HOFFMAN, EXAMINING ATTORNEY

CLASS 36—(Continued).

SN 85-250,315. ALLIANCE BANK, N.A., SYRACUSE, NY. FILED 2-24-2011.

PERSONAL eSUITE

THE MARK CONSISTS OF STANDARD CHARACTERS WITHOUT CLAIM TO ANY PARTICULAR FONT, STYLE, SIZE, OR COLOR.

NO CLAIM IS MADE TO THE EXCLUSIVE RIGHT TO USE "PERSONAL", APART FROM THE MARK AS SHOWN.

FOR ONLINE FINANCIAL SERVICES, NAMELY, BANKING SERVICES, BILL PAYMENT SERVICES, AND FINANCIAL MANAGEMENT SERVICES (U.S. CLS. 100, 101 AND 102).

CHRISTOPHER BUONGIORNO, EXAMINING ATTORNEY

SN 85-250,403. GIVEPATH, LLC, COLLEGE STATION, TX. FILED 2-24-2011.

SNOBALL

THE MARK CONSISTS OF STANDARD CHARACTERS WITHOUT CLAIM TO ANY PARTICULAR FONT, STYLE, SIZE, OR COLOR.

FOR CHARITABLE FUNDRAISING; PROVIDING FUNDRAISING SERVICES FOR OTHERS VIA A GLOBAL COMPUTER NETWORK (U.S. CLS. 100, 101 AND 102).

ROBERT C. CLARK JR., EXAMINING ATTORNEY

SN 85-252,405. HARTLEY CYLKE PACIFIC INSURANCE SERVICE INC., SAN DIEGO, CA. FILED 2-25-2011.

Southwestern Select

THE MARK CONSISTS OF STANDARD CHARACTERS WITHOUT CLAIM TO ANY PARTICULAR FONT, STYLE, SIZE, OR COLOR.

NO CLAIM IS MADE TO THE EXCLUSIVE RIGHT TO USE "SELECT", APART FROM THE MARK AS SHOWN.

FOR INSURANCE BROKERAGE IN THE FIELD OF TRUCK INSURANCE FOR TRUCKING FLEETS AND TRANSPORTATION COMPANIES AND THEIR DRIVERS (U.S. CLS. 100, 101 AND 102).

FIRST USE 2-1-2005; IN COMMERCE 2-1-2006.

JULIE GUTTADAURO, EXAMINING ATTORNEY

CLASS 36—(Continued).

SN 85-253,082. MOTORISTS MUTUAL INSURANCE COMPANY, COLUMBUS, OH. FILED 2-28-2011.

Motorists Commercial Mutual Insurance Company

THE MARK CONSISTS OF STANDARD CHARACTERS WITHOUT CLAIM TO ANY PARTICULAR FONT, STYLE, SIZE, OR COLOR.

OWNER OF U.S. REG. NOS. 989,185 AND 2,688,520.

NO CLAIM IS MADE TO THE EXCLUSIVE RIGHT TO USE "COMMERCIAL MUTUAL INSURANCE COMPANY", APART FROM THE MARK AS SHOWN.

SEC. 2(F) AS TO "MOTORISTS".

FOR COMMERCIAL PROPERTY AND CASUALTY INSURANCE UNDERWRITING SERVICES (U.S. CLS. 100, 101 AND 102).

CARRIE GENOVESE, EXAMINING ATTORNEY

SN 85-253,089. MOTORISTS MUTUAL INSURANCE COMPANY, COLUMBUS, OH. FILED 2-28-2011.

Motorists Mutual Insurance Company

THE MARK CONSISTS OF STANDARD CHARACTERS WITHOUT CLAIM TO ANY PARTICULAR FONT, STYLE, SIZE, OR COLOR.

OWNER OF U.S. REG. NOS. 989,185 AND 2,688,520.

NO CLAIM IS MADE TO THE EXCLUSIVE RIGHT TO USE "MUTUAL INSURANCE COMPANY", APART FROM THE MARK AS SHOWN.

SEC. 2(F) AS TO "MOTORISTS".

FOR HOME, BUSINESS AND LIFE INSURANCE UNDERWRITING SERVICES (U.S. CLS. 100, 101 AND 102).

FIRST USE 1-20-1973; IN COMMERCE 1-20-1973.

CARRIE GENOVESE, EXAMINING ATTORNEY

SN 85-254,193. GEPII VINCENT A., CATONSVILLE, MD. FILED 3-1-2011.

Gianni's Fundraising

THE MARK CONSISTS OF STANDARD CHARACTERS WITHOUT CLAIM TO ANY PARTICULAR FONT, STYLE, SIZE, OR COLOR.

NO CLAIM IS MADE TO THE EXCLUSIVE RIGHT TO USE "FUNDRAISING", APART FROM THE MARK AS SHOWN.

FOR FUNDRAISING SERVICES, NAMELY, ORGANIZING FUNDRAISERS FOR SCHOOLS AND OTHER GROUPS (U.S. CLS. 100, 101 AND 102).

JEFFERY COWARD, EXAMINING ATTORNEY

CLASS 36—(Continued).

SN 85-256,333. WORLD FX IQ, INC., LYNWOOD, WA. FILED 3-2-2011.



NO CLAIM IS MADE TO THE EXCLUSIVE RIGHT TO USE "FX" AND "TRADIO", APART FROM THE MARK AS SHOWN.

THE STIPPLING IS FOR SHADING PURPOSES ONLY.

THE MARK CONSISTS OF A VINTAGE, OUTLINED "50'S" SIGN WITH A PICTURE OF AN OLD TIME RADIO. A CANDLESTICK CHART IS BEHIND THE LETTERS "FX" ON THE SIGN AND NEXT TO THE RADIO. THE WORDS "FX TRADIO PIPIFY ME!" ARE STYLIZED, AND "PIPIFY ME!" ARE AT THE BOTTOM RIGHT OF THE SIGN.

FOR FINANCIAL SERVICES, NAMELY, PROVIDING FOR THE EXCHANGE OF FOREIGN CURRENCY, COMMODITIES, FINANCIAL DERIVATIVES, INTEREST RATE PRODUCTS, AND EQUITIES VIA THE INTERNET AND INTRANET SYSTEMS (U.S. CLS. 100, 101 AND 102).

ASMAT KHAN, EXAMINING ATTORNEY

CLASS 36—(Continued).

SN 85-260,481. THE CHUBB CORPORATION, WARREN, NJ. FILED 3-8-2011.

DecisionPoint

THE MARK CONSISTS OF STANDARD CHARACTERS WITHOUT CLAIM TO ANY PARTICULAR FONT, STYLE, SIZE, OR COLOR.

FOR INSURANCE SERVICES, NAMELY, PROVIDING PREMIUM RATE QUOTES VIA ON-LINE MEANS IN THE FIELDS OF MANAGEMENT AND PROFESSIONAL LIABILITY INSURANCE (U.S. CLS. 100, 101 AND 102).

HAI-LY LAM, EXAMINING ATTORNEY

SN 85-260,517. THE SURETY & FIDELITY ASSOCIATION OF AMERICA, WASHINGTON, DC. FILED 3-8-2011.

Model Contractor Development Program

THE MARK CONSISTS OF STANDARD CHARACTERS WITHOUT CLAIM TO ANY PARTICULAR FONT, STYLE, SIZE, OR COLOR.

SEC. 2(F).

FOR PROVIDING TECHNICAL INFORMATION IN THE FIELD OF SURETY BONDING FOR SMALL CONSTRUCTION FIRMS (U.S. CLS. 100, 101 AND 102).

FIRST USE 5-11-2000; IN COMMERCE 5-11-2000.

GEOFFREY FOSDICK, EXAMINING ATTORNEY

SN 85-259,600. T. ROWE PRICE GROUP, INC., BALTIMORE, MD. FILED 3-7-2011.



OWNER OF U.S. REG. NOS. 868,521, 3,046,696 AND OTHERS.

THE MARK CONSISTS OF A STYLIZED BIGHORN SHEEP.

FOR HOUSE MARK FOR PROVIDING A FULL RANGE OF SERVICES IN THE INVESTMENT AND FINANCIAL FIELD, NAMELY, BANKING, INVESTMENT BROKERAGE, INVESTMENT MANAGEMENT, ASSET MANAGEMENT, INVESTMENT ADVICE, INVESTMENT CONSULTATION, FINANCIAL RESEARCH, COLLEGE SAVINGS PLANS, CHARITABLE GIVING, RETIREMENT PLANNING, AND VARIABLE ANNUITIES INVESTMENT (U.S. CLS. 100, 101 AND 102).

FIRST USE 0-0-2001; IN COMMERCE 0-0-2001.

ELIZABETH HUGHITT, EXAMINING ATTORNEY

SN 85-261,824. LANE BRYANT PURCHASING CORP., COLUMBUS, OH. FILED 3-9-2011.

Take credit for your curves.

THE MARK CONSISTS OF STANDARD CHARACTERS WITHOUT CLAIM TO ANY PARTICULAR FONT, STYLE, SIZE, OR COLOR.

FOR CREDIT CARD AND FINANCIAL SERVICES, NAMELY, CREDIT CARD VERIFICATIONS, ISSUING OF CREDIT CARDS, AND PROVIDING CASH AND OTHER REBATES FOR CREDIT CARD USE AS PART OF A CUSTOMER LOYALTY PROGRAM (U.S. CLS. 100, 101 AND 102).

FIRST USE 12-5-2010; IN COMMERCE 12-5-2010.

KEVIN CORWIN, EXAMINING ATTORNEY

CLASS 36—(Continued).

SN 85-262,037. SILVERHAWK FINANCIAL SERVICES, INC., DBA SILVERHAWK FINANCIAL, SCOTTSDALE, AZ. FILED 3-9-2011.



THE MARK CONSISTS OF THE STYLIZED IMAGE OF A BIRD'S HEAD WITH THE WORD "SILVER" UNDERLINED AND IN CAPITAL LETTERS APPEARING THE LEFT OF THE IMAGE, AND THE WORD "HAWK" UNDERLINED AND IN CAPITAL LETTERS APPEARING TO THE RIGHT OF THE BIRD'S HEAD.

FOR FINANCIAL PLANNING (U.S. CLS. 100, 101 AND 102).

FIRST USE 4-1-2006; IN COMMERCE 7-14-2006.

CHARLES L. JENKINS, EXAMINING ATTORNEY

CLASS 36—(Continued).

SN 85-263,704. TRITON PACIFIC GROUP, INC., LOS ANGELES, CA. FILED 3-10-2011.



THE COLOR(S) BROWN AND WHITE IS/ARE CLAIMED AS A FEATURE OF THE MARK.

THE MARK CONSISTS OF A DESIGN OF AN ARMILLARY SPHERE IN BROWN WITH WHITE HIGHLIGHTING HAVING A BROWN ARROW AND SET ON A ROUNDED PEDESTAL THAT IS BROWN WITH WHITE HIGHLIGHTING.

FOR EQUITY CAPITAL INVESTMENT; MANAGEMENT OF PRIVATE EQUITY FUNDS; PRIVATE EQUITY FUND INVESTMENT SERVICES; PROVIDING VENTURE CAPITAL, DEVELOPMENT CAPITAL, PRIVATE EQUITY AND INVESTMENT FUNDING (U.S. CLS. 100, 101 AND 102).

FIRST USE 1-1-2007; IN COMMERCE 1-1-2007.

HAI-LY LAM, EXAMINING ATTORNEY

SN 85-263,028. STOREHOUSE INVESTMENT MANAGEMENT LTD., HAMILTON, BERMUDA, FILED 3-10-2011.



THE MARK CONSISTS OF A SQUARE WITH A STYLIZED IMAGE OF A BUILDING CONSISTING OF THREE VERTICAL LINES.

FOR FINANCIAL SERVICES, NAMELY, CHARITABLE TRUST ADMINISTRATION, HEDGE FUND INVESTMENT SERVICES, AND INVESTMENT ADVISORY SERVICES (U.S. CLS. 100, 101 AND 102).

LINDA M. KING, EXAMINING ATTORNEY

SN 85-266,769. LEGG MASON INVESTOR SERVICES, LLC, BALTIMORE, MD. FILED 3-14-2011.

SAVE AT WORK. BECAUSE IT WORKS.

THE MARK CONSISTS OF STANDARD CHARACTERS WITHOUT CLAIM TO ANY PARTICULAR FONT, STYLE, SIZE, OR COLOR.

FOR FINANCIAL PLANNING FOR RETIREMENT (U.S. CLS. 100, 101 AND 102).

DAWN HAN, EXAMINING ATTORNEY

SN 85-267,936. TRADESECURE, WILMINGTON, DE. FILED 3-15-2011.



NO CLAIM IS MADE TO THE EXCLUSIVE RIGHT TO USE "SECURE", "GLOBAL", AND "TRADING", APART FROM THE MARK AS SHOWN.

THE MARK CONSISTS OF THE TERM "TRADESECURE" ABOVE THE TERM "SECURE. GLOBAL. TRADING." ALL TO THE RIGHT OF A STYLIZED DEPICTION OF INTERLOCKING PARTIAL RINGS.

FOR FOREIGN EXCHANGE INFORMATION SERVICES; FOREIGN EXCHANGE TRANSACTIONS (U.S. CLS. 100, 101 AND 102).

JIM RINGLE, EXAMINING ATTORNEY

CLASS 36—(Continued).

SN 85-268,535. FCCI MUTUAL INSURANCE HOLDING COMPANY, SARASOTA, FL. FILED 3-16-2011.

FCCI-GROUP.COM

THE MARK CONSISTS OF STANDARD CHARACTERS WITHOUT CLAIM TO ANY PARTICULAR FONT, STYLE, SIZE, OR COLOR.

OWNER OF U.S. REG. NO. 2,607,167.
FOR INSURANCE SERVICES, NAMELY, UNDERWRITING, ISSUANCE AND ADMINISTRATION OF PROPERTY AND CASUALTY INSURANCE; PROVIDING A WEBSITE FEATURING EDUCATIONAL INFORMATION IN THE FIELD OF BUSINESS INSURANCE (U.S. CLS. 100, 101 AND 102).

KIM MONINGHOFF, EXAMINING ATTORNEY

SN 85-268,685. ALLSTATE INSURANCE COMPANY, NORTHBROOK, IL. FILED 3-16-2011.



NO CLAIM IS MADE TO THE EXCLUSIVE RIGHT TO USE "CLAIM SATISFACTION GUARANTEED", APART FROM THE MARK AS SHOWN.

THE MARK CONSISTS OF THE WORDS "CLAIM SATISFACTION GUARANTEED" TO THE RIGHT OF THE CUPPED HANDS DESIGN ON A DARK BACKGROUND, INSIDE A FRAME WITH RIVETS ON THE CORNERS.

FOR PROVIDING MONEY BACK GUARANTEE SERVICES FOR PROPERTY AND CASUALTY INSURANCE FOR A SELECT GROUP OF INSURANCE CUSTOMERS (U.S. CLS. 100, 101 AND 102).

FIRST USE 12-31-2010; IN COMMERCE 12-31-2010.
WILLIAM ROSSMAN, EXAMINING ATTORNEY

SN 85-268,995. HAGEMANN, MICHAEL K., CENTURY CITY, CA. FILED 3-16-2011.

CALIFORNIA BREEZE

THE MARK CONSISTS OF STANDARD CHARACTERS WITHOUT CLAIM TO ANY PARTICULAR FONT, STYLE, SIZE, OR COLOR.

NO CLAIM IS MADE TO THE EXCLUSIVE RIGHT TO USE "CALIFORNIA", APART FROM THE MARK AS SHOWN.

FOR COMMERCIAL AND RESIDENTIAL REAL ESTATE AGENCY SERVICES; REAL ESTATE SERVICE, NAMELY, RENTAL PROPERTY MANAGEMENT; REAL ESTATE SERVICES, NAMELY, PROPERTY MANAGEMENT SERVICES FOR CONDOMINIUM ASSOCIATIONS, HOMEOWNER ASSOCIATIONS AND APARTMENT BUILDINGS (U.S. CLS. 100, 101 AND 102).

TAMARA FRAZIER, EXAMINING ATTORNEY

CLASS 36—(Continued).

SN 85-269,591. CLINTON, MICHAEL, BEVERLY HILLS, CA. FILED 3-17-2011.

GAUNTLET
COMMERCIAL REAL ESTATE CAPITAL

NO CLAIM IS MADE TO THE EXCLUSIVE RIGHT TO USE "COMMERCIAL REAL ESTATE CAPITAL", APART FROM THE MARK AS SHOWN.

THE MARK CONSISTS OF THE WORD "GAUNTLET" IN ALL CAPITAL LETTERS WITH THE LETTER "A" REPLACED WITH A BUILDING THAT ALSO LOOKS LIKE A PATH LEADING INTO THE FUTURE OR BACKGROUND, AND "COMMERCIAL REAL ESTATE CAPITAL" WRITTEN BELOW "GAUNTLET".

FOR REAL ESTATE CONSULTATION; REAL ESTATE BROKERAGE; REAL ESTATE SERVICE, NAMELY, RENTAL PROPERTY MANAGEMENT; REAL ESTATE APPRAISAL; INVESTMENT BANKING SERVICES STRUCTURING AND ARRANGING DEBT AND EQUITY FOR THE ACQUISITION AND REFINANCING OF COMMERCIAL REAL ESTATE PROPERTIES AND BUSINESSES (U.S. CLS. 100, 101 AND 102).

FIRST USE 3-1-2009; IN COMMERCE 3-1-2009.
JIM RINGLE, EXAMINING ATTORNEY

SN 85-269,806. CONWAY, MICHAEL W., CALIFON, NJ. FILED 3-17-2011.

CONWAY WEALTH GROUP

THE MARK CONSISTS OF STANDARD CHARACTERS WITHOUT CLAIM TO ANY PARTICULAR FONT, STYLE, SIZE, OR COLOR.

NO CLAIM IS MADE TO THE EXCLUSIVE RIGHT TO USE "WEALTH GROUP", APART FROM THE MARK AS SHOWN.

FOR FINANCIAL SERVICES, NAMELY, WEALTH MANAGEMENT SERVICES; PROVIDING FINANCIAL SERVICES WITH RESPECT TO SECURITIES AND OTHER FINANCIAL INSTRUMENTS AND PRODUCTS, NAMELY, MONEY MANAGEMENT SERVICES (U.S. CLS. 100, 101 AND 102).

ELIZABETH HUGHITT, EXAMINING ATTORNEY

CLASS 36—(Continued).

SN 85-269,843. PRESPOINT CAPITAL, LLC, SAN FRANCISCO, CA. FILED 3-17-2011.



OWNER OF U.S. REG. NO. 3,520,164.
THE COLOR(S) DARK BLUE AND BLACK IS/ARE CLAIMED AS A FEATURE OF THE MARK.
THE MARK CONSISTS OF AN ABSTRACT DESIGN OF A MAN IN DARK BLUE WITH HIS HANDS ON HIS HIPS FORMED BY TWO STYLIZED LETTER "P"S POSITIONED BACK TO BACK; ABOVE AND CENTERED BETWEEN THE TWO LETTER "P"S IS A DOT CREATING THE HEAD OF THE MAN AND REPRESENTING "POINT" IN THE WORD "PRESPOINT"; UNDERNEATH IN LARGE FONT IS THE STYLIZED WORD "PRESPOINT" IN BLACK.
FOR HEDGE FUND INVESTMENT SERVICES (U.S. CLS. 100, 101 AND 102).
FIRST USE 3-30-2010; IN COMMERCE 3-30-2010.
JULIE GUTTADAURO, EXAMINING ATTORNEY

SN 85-270,579. AMALGAMATED BANK, NEW YORK, NY. FILED 3-18-2011.

LONGVIEW QUANTITATIVE
LARGECAP FUND

THE MARK CONSISTS OF STANDARD CHARACTERS WITHOUT CLAIM TO ANY PARTICULAR FONT, STYLE, SIZE, OR COLOR.
OWNER OF U.S. REG. NOS. 2,056,805, 2,876,948 AND OTHERS.
NO CLAIM IS MADE TO THE EXCLUSIVE RIGHT TO USE "QUANTITATIVE LARGECAP FUND", APART FROM THE MARK AS SHOWN.
FOR FINANCIAL SERVICES, NAMELY, INVESTMENT ADVISORY SERVICES, INVESTMENT MANAGEMENT SERVICES, ASSET MANAGEMENT SERVICES, AND THE COLLECTIVE INVESTMENT AND REINVESTMENT OF FUNDS (U.S. CLS. 100, 101 AND 102).
FIRST USE 1-1-1997; IN COMMERCE 1-1-1997.
MARK SHINER, EXAMINING ATTORNEY

CLASS 36—(Continued).

SN 85-270,582. AMALGAMATED BANK, NEW YORK, NY. FILED 3-18-2011.

LONGVIEW INTERNATIONAL
VALUE EQUITY FUND

THE MARK CONSISTS OF STANDARD CHARACTERS WITHOUT CLAIM TO ANY PARTICULAR FONT, STYLE, SIZE, OR COLOR.
OWNER OF U.S. REG. NOS. 2,056,805, 2,876,948 AND OTHERS.
NO CLAIM IS MADE TO THE EXCLUSIVE RIGHT TO USE "INTERNATIONAL VALUE EQUITY FUND", APART FROM THE MARK AS SHOWN.
FOR INVESTMENT SERVICES, NAMELY, THE COLLECTIVE INVESTMENT AND REINVESTMENT OF ACTIVELY MANAGED FUNDS OF ELIGIBLE TRUSTS (U.S. CLS. 100, 101 AND 102).
FIRST USE 11-1-2005; IN COMMERCE 11-1-2005.
MARK SHINER, EXAMINING ATTORNEY

SN 85-271,795. 3G FINANCIAL SOLUTIONS, LLC, SAN DIEGO, CA. FILED 3-21-2011.

Mi Adelanto

THE MARK CONSISTS OF STANDARD CHARACTERS WITHOUT CLAIM TO ANY PARTICULAR FONT, STYLE, SIZE, OR COLOR.
THE ENGLISH TRANSLATION OF "MI ADELANTO" IN THE MARK IS "MY ADVANCE".
FOR CREDIT AND LOAN SERVICES (U.S. CLS. 100, 101 AND 102).
SKYE YOUNG, EXAMINING ATTORNEY

SN 85-272,221. CFC PUBLISHING OTD, INC., MANALAPAN, NJ. FILED 3-21-2011.



NO CLAIM IS MADE TO THE EXCLUSIVE RIGHT TO USE "HEALTHCARE", APART FROM THE MARK AS SHOWN.
THE COLOR(S) BLACK AND BLUE IS/ARE CLAIMED AS A FEATURE OF THE MARK.
THE MARK CONSISTS OF THE STYLIZED WORDING "ERISA HEALTHCARE" WHERE THE "R" IN "ERISA" HAS A SUBSCRIPT "X" TO RESEMBLE "RX". "HEALTHCARE" AND THE "RX" IN "ERISA" ARE BLUE. THE "E" AND "ISA" IN "ERISA" ARE BLACK.
FOR ADMINISTRATION AND ORGANIZING OF THE SELF-FUNDED HEALTH CARE PLANS OF OTHERS (U.S. CLS. 100, 101 AND 102).
KIM SAITO, EXAMINING ATTORNEY

CLASS 36—(Continued).

SN 85-273,270. STRATFORD ARMS, L.P., AUSTIN, TX. FILED 3-22-2011.

STRATFORD ARMS

THE MARK CONSISTS OF STANDARD CHARACTERS WITHOUT CLAIM TO ANY PARTICULAR FONT, STYLE, SIZE, OR COLOR.

FOR REAL ESTATE SERVICES, NAMELY, RENTAL OF VACATION HOMES (U.S. CLS. 100, 101 AND 102).
JENNIFER MARTIN, EXAMINING ATTORNEY

CLASS 36—(Continued).

SN 85-273,713. CASTLE INSURANCE AGENCY, INC., DEERFIELD, IL. FILED 3-22-2011.



The logo features the word "SOUL" in a large, bold, sans-serif font with a horizontal gradient from dark to light. Below it, the words "you know" are written in a smaller, lowercase, sans-serif font.

THE MARK CONSISTS OF THE WORD "SOUL" WITH LEFT TO RIGHT SHADING GRADATIONS FROM DARK TO LIGHT TO DARK ABOVE THE WORDS "YOU KNOW".

FOR INSURANCE AGENCY AND UNDERWRITING SERVICES, NAMELY, PROVIDING LIFE INSURANCE AND ANNUITY POLICIES, PRE-NEED FUNERAL POLICIES, BURIAL AND FINAL EXPENSE LIFE INSURANCE; INSURANCE UNDERWRITING IN THE FIELD OF LIFE INSURANCE, PRE-NEED FUNERAL INSURANCE, BURIAL AND FINAL EXPENSE LIFE INSURANCE (U.S. CLS. 100, 101 AND 102).

JUDITH HELFMAN, EXAMINING ATTORNEY

SN 85-273,795. HYPOR CAPITAL PARTNERS LLC, PHILADELPHIA, PA. FILED 3-22-2011.

HYPOR CAPITAL PARTNERS

THE MARK CONSISTS OF STANDARD CHARACTERS WITHOUT CLAIM TO ANY PARTICULAR FONT, STYLE, SIZE, OR COLOR.

NO CLAIM IS MADE TO THE EXCLUSIVE RIGHT TO USE "CAPITAL PARTNERS", APART FROM THE MARK AS SHOWN.

FOR INVESTMENT MANAGEMENT SERVICES (U.S. CLS. 100, 101 AND 102).

MATTHEW MCDOWELL, EXAMINING ATTORNEY

SN 85-273,689. CASTLE INSURANCE AGENCY, INC., DEERFIELD, IL. FILED 3-22-2011.



The logo features the word "SOUL" in a large, bold, sans-serif font with a vertical gradient from orange to blue. Below it, the words "you know" are written in a smaller, lowercase, sans-serif font.

THE COLOR(S) BLUE AND ORANGE IS/ARE CLAIMED AS A FEATURE OF THE MARK.

THE MARK CONSISTS OF THE WORD "SOUL" WITH LEFT TO RIGHT COLOR GRADATIONS FROM ORANGE TO BLUE TO ORANGE ABOVE THE WORDS "YOU KNOW" IN BLUE LETTERS.

FOR INSURANCE AGENCY AND UNDERWRITING SERVICES, NAMELY, PROVIDING LIFE INSURANCE AND ANNUITY POLICIES, PRE-NEED FUNERAL POLICIES, BURIAL AND FINAL EXPENSE LIFE INSURANCE; INSURANCE UNDERWRITING IN THE FIELD OF LIFE INSURANCE, PRE-NEED FUNERAL INSURANCE, BURIAL AND FINAL EXPENSE LIFE INSURANCE (U.S. CLS. 100, 101 AND 102).

JUDITH HELFMAN, EXAMINING ATTORNEY

SN 85-273,950. ALLOS INVESTMENT ADVISORS, LLC, OVERLAND PARK, KS. FILED 3-22-2011.

Allos Investment Advisors

THE MARK CONSISTS OF STANDARD CHARACTERS WITHOUT CLAIM TO ANY PARTICULAR FONT, STYLE, SIZE, OR COLOR.

NO CLAIM IS MADE TO THE EXCLUSIVE RIGHT TO USE "INVESTMENT ADVISORS", APART FROM THE MARK AS SHOWN.

FOR FINANCIAL PLANNING; INVESTMENT ADVISORY SERVICES; INVESTMENT MANAGEMENT (U.S. CLS. 100, 101 AND 102).

FIRST USE 2-18-2011; IN COMMERCE 2-18-2011.

ALYSSA STEEL, EXAMINING ATTORNEY

CLASS 36—(Continued).

SN 85-274,151. MERCHANTS' GATE CAPITAL LP, NEW YORK, NY. FILED 3-23-2011.

MERCHANTS' GATE

THE MARK CONSISTS OF STANDARD CHARACTERS WITHOUT CLAIM TO ANY PARTICULAR FONT, STYLE, SIZE, OR COLOR.

OWNER OF U.S. REG. NO. 3,440,062.
FOR FINANCIAL SERVICES, NAMELY, ASSET MANAGEMENT SERVICES, INVESTMENT MANAGEMENT SERVICES AND INVESTMENT ADVISORY SERVICES (U.S. CLS. 100, 101 AND 102).

FIRST USE 8-0-2007; IN COMMERCE 8-0-2007.
HELENE LIWINSKI, EXAMINING ATTORNEY

SN 85-274,208. AMERICAN DOCUMENTARIES, INC., WALPOLE, NH. FILED 3-23-2011.

THE BETTER ANGELS SOCIETY

THE MARK CONSISTS OF STANDARD CHARACTERS WITHOUT CLAIM TO ANY PARTICULAR FONT, STYLE, SIZE, OR COLOR.

NO CLAIM IS MADE TO THE EXCLUSIVE RIGHT TO USE "SOCIETY", APART FROM THE MARK AS SHOWN.

FOR CHARITABLE FUNDRAISING SERVICES IN CONNECTION WITH MEDIA-AND ENTERTAINMENT-RELATED PROJECTS (U.S. CLS. 100, 101 AND 102).

FIRST USE 12-31-2009; IN COMMERCE 12-31-2009.
REBECCA GILBERT, EXAMINING ATTORNEY

SN 85-274,463. POPULAR, INC., SAN JUAN, PUERTO RICO, FILED 3-23-2011.

El Banco del Pueblo

THE MARK CONSISTS OF STANDARD CHARACTERS WITHOUT CLAIM TO ANY PARTICULAR FONT, STYLE, SIZE, OR COLOR.

NO CLAIM IS MADE TO THE EXCLUSIVE RIGHT TO USE "BANCO", APART FROM THE MARK AS SHOWN.

THE ENGLISH TRANSLATION OF "EL BANCO DEL PUEBLO" IN THE MARK IS "THE BANK OF THE PEOPLE".

FOR BANKING AND FINANCING SERVICES (U.S. CLS. 100, 101 AND 102).

MARK SHINER, EXAMINING ATTORNEY

CLASS 36—(Continued).

SN 85-274,788. CWS APARTMENT HOMES, LLC, AUSTIN, TX. FILED 3-23-2011.



NO CLAIM IS MADE TO THE EXCLUSIVE RIGHT TO USE "WEST CAMPUS", APART FROM THE MARK AS SHOWN.

THE COLOR(S) RED AND BLACK IS/ARE CLAIMED AS A FEATURE OF THE MARK.

THE MARK CONSISTS OF THE WORDING "I" IN BLACK, FOLLOWED BY A RED HEART DESIGN, AND BENEATH APPEARS THE WORDING "WEST CAMPUS" IN BLACK; THE COLOR WHITE IS NOT PART OF THE MARK AND REPRESENTS TRANSPARENT BACKGROUND.

FOR HOUSING SERVICES, NAMELY, RENTAL OF STUDENT HOUSING; MANAGEMENT OF APARTMENTS (U.S. CLS. 100, 101 AND 102).

FIRST USE 2-23-2011; IN COMMERCE 2-23-2011.
AMY C. KEAN, EXAMINING ATTORNEY

SN 85-274,789. AMERICAN TITLE LENDERS, LLC, TAMPA, FL. FILED 3-23-2011.



NO CLAIM IS MADE TO THE EXCLUSIVE RIGHT TO USE "TITLE LENDERS", APART FROM THE MARK AS SHOWN.

THE COLOR(S) RED, WHITE, BLACK AND GRAY IS/ARE CLAIMED AS A FEATURE OF THE MARK.

THE MARK CONSISTS OF THE FANCIFUL DESIGN OF THE FRONT PART OF THE HEAD OF THE STATUE OF LIBERTY IN GRAY AND BLACK WITH WHITE HIGHLIGHTS ON THE FACE, CONNECTED TO THE LEFT SIDE OF THE "A" OF THE WORD "AMERICAN" THE LETTERS OF WHICH ARE IMPRINTED WITH THE REPRESENTATION OF THE AMERICAN FLAG IN RED, WHITE AND BLACK, ABOVE THE WORDS, "TITLE LENDERS", IN WHITE OUTLINED IN BLACK.

SEC. 2(F) AS TO "AMERICAN".

FOR COMMERCIAL LENDING SERVICES; CONSUMER LENDING SERVICES; FINANCIAL SERVICES, NAMELY, MONEY LENDING; FINANCIAL SERVICES, NAMELY, VEHICLE TITLE LOANS; FINANCING AND LOAN SERVICES; FINANCING SERVICES (U.S. CLS. 100, 101 AND 102).

FIRST USE 1-15-2006; IN COMMERCE 1-15-2006.
BARBARA A. GOLD, EXAMINING ATTORNEY

CLASS 36—(Continued).

SN 85-274,790. FRESH ARTISTS, LAFAYETTE HILL, PA.
FILED 3-23-2011.

fresh artists

THE MARK CONSISTS OF STANDARD CHARACTERS WITHOUT CLAIM TO ANY PARTICULAR FONT, STYLE, SIZE, OR COLOR.

NO CLAIM IS MADE TO THE EXCLUSIVE RIGHT TO USE "ARTISTS", APART FROM THE MARK AS SHOWN.

FOR CHARITABLE FOUNDATION SERVICES, NAMELY, PROVIDING FUNDRAISING ACTIVITIES, FUNDING, AND ADMINISTERING MONETARY CHARITABLE CONTRIBUTIONS FOR THE PURPOSE OF SUPPORTING ART PROGRAMS IN PUBLIC EDUCATION, PUBLICLY EXHIBITING CHILDREN'S ARTWORK, AND PROVIDING ARTS AND CRAFTS SUPPLIES TO STUDENTS, TEACHERS AND SCHOOLS IN NEED (U.S. CLS. 100, 101 AND 102).

FIRST USE 5-31-2006; IN COMMERCE 12-31-2007.

BARBARA A. GOLD, EXAMINING ATTORNEY

CLASS 36—(Continued).

SN 85-275,682. THROUGH KYLE'S EYES FOUNDATION, INC., MURRIETA, CA. FILED 3-24-2011.

THROUGH KYLE'S EYES

SN 85-274,938. REPUBLIC BUSINESS CREDIT, LLC, NEW ORLEANS, LA. FILED 3-23-2011.

Republic Business Credit

THE MARK CONSISTS OF STANDARD CHARACTERS WITHOUT CLAIM TO ANY PARTICULAR FONT, STYLE, SIZE, OR COLOR.

NO CLAIM IS MADE TO THE EXCLUSIVE RIGHT TO USE "BUSINESS CREDIT", APART FROM THE MARK AS SHOWN.

FOR FINANCING SERVICES, ACCOUNTS RECEIVABLES FINANCING (U.S. CLS. 100, 101 AND 102).

FIRST USE 11-16-2010; IN COMMERCE 1-26-2011.

CYNTHIA SLOAN, EXAMINING ATTORNEY

SN 85-275,485. PALMSTAR MEDIA CAPITAL LLC, SHERMAN OAKS, CA. FILED 3-24-2011.

PALMSTAR MEDIA CAPITAL

THE MARK CONSISTS OF STANDARD CHARACTERS WITHOUT CLAIM TO ANY PARTICULAR FONT, STYLE, SIZE, OR COLOR.

NO CLAIM IS MADE TO THE EXCLUSIVE RIGHT TO USE "MEDIA CAPITAL", APART FROM THE MARK AS SHOWN.

FOR MEDIA INVESTMENT FUNDS MANAGEMENT AND INVESTMENT SERVICES (U.S. CLS. 100, 101 AND 102).

FIRST USE 3-31-2010; IN COMMERCE 3-31-2010.

JANICE L. MCMORROW, EXAMINING ATTORNEY

THE MARK CONSISTS OF STANDARD CHARACTERS WITHOUT CLAIM TO ANY PARTICULAR FONT, STYLE, SIZE, OR COLOR.

FOR CHARITABLE FUNDRAISING; CHARITABLE FUNDRAISING SERVICES; CHARITABLE FOUNDATION SERVICES, NAMELY, PROVIDING FUNDRAISING ACTIVITIES TO SUPPORT SCIENTIFIC AND CLINICAL RESEARCH, AND DEVELOPMENT OF MEDICAL TREATMENTS IN THE FIELD OF RETINOBLASTOMA; CHARITABLE FUNDRAISING SERVICES, NAMELY, ORGANIZING EVENTS TO RAISE FUNDS FOR RETINOBLASTOMA RESEARCH; CHARITABLE FUNDRAISING SERVICES BY MEANS OF A GOLF EVENT; CHARITABLE FUNDRAISING SERVICES BY MEANS OF SELLING GOLF APPAREL AND GOLF ACCESSORIES; ELEEMOSYNARY SERVICES IN THE FIELD OF MONETARY DONATIONS TO CHARITIES SUPPORTING CHILDREN; PROVIDING CHARITABLE FUNDRAISING INFORMATION VIA THE INTERNET; CHARITABLE FUNDRAISING SERVICES, NAMELY, ACCEPTING AND ADMINISTERING MONETARY CHARITABLE CONTRIBUTIONS FROM THE PUBLIC THROUGH A GLOBAL COMPUTER NETWORK (U.S. CLS. 100, 101 AND 102).

FIRST USE 3-27-2009; IN COMMERCE 3-27-2009.

DAWN HAN, EXAMINING ATTORNEY

CLASS 36—(Continued).

SN 85-275,768. THROUGH KYLE'S EYES FOUNDATION, INC., MURRIETA, CA. FILED 3-24-2011.



NO CLAIM IS MADE TO THE EXCLUSIVE RIGHT TO USE "FOUNDATION", APART FROM THE MARK AS SHOWN.

THE MARK CONSISTS OF A RECTANGULAR OUTLINE CONTAINING THE DESIGN OF A GOLFER HOLDING A GOLF CLUB AT THE END OF HIS SWING AGAINST THE BACKGROUND OF THE SKY AND CLOUDS ATOP A SHADED RECTANGULAR BOX THAT CONTAINS THE WORDING "THROUGH KYLE'S EYES FOUNDATION" IN A STACKED CENTERED CONFIGURATION.

FOR CHARITABLE FUNDRAISING; CHARITABLE FUNDRAISING SERVICES; CHARITABLE FOUNDATION SERVICES, NAMELY, PROVIDING FUNDRAISING ACTIVITIES TO SUPPORT SCIENTIFIC AND CLINICAL RESEARCH, AND DEVELOPMENT OF MEDICAL TREATMENTS IN THE FIELD OF RETINOBLASTOMA; CHARITABLE FUNDRAISING SERVICES, NAMELY, ORGANIZING EVENTS TO RAISE FUNDS FOR RETINOBLASTOMA RESEARCH; CHARITABLE FUNDRAISING SERVICES BY MEANS OF A GOLF EVENT; CHARITABLE FUNDRAISING SERVICES BY MEANS OF SELLING GOLF APPAREL AND GOLF ACCESSORIES; ELEEMOSYNARY SERVICES IN THE FIELD OF MONETARY DONATIONS TO CHARITIES SUPPORTING CHILDREN; PROVIDING CHARITABLE FUNDRAISING INFORMATION VIA THE INTERNET; CHARITABLE FUNDRAISING SERVICES, NAMELY, ACCEPTING AND ADMINISTERING MONETARY CHARITABLE CONTRIBUTIONS FROM THE PUBLIC THROUGH A GLOBAL COMPUTER NETWORK (U.S. CLS. 100, 101 AND 102).

FIRST USE 1-16-2011; IN COMMERCE 1-16-2011.

DAWN HAN, EXAMINING ATTORNEY

CLASS 36—(Continued).

SN 85-276,104. SELFRELIANCE UKRAINIAN AMERICAN FEDERAL CREDIT UNION, CHICAGO, IL. FILED 3-24-2011.



NO CLAIM IS MADE TO THE EXCLUSIVE RIGHT TO USE "UKRAINIAN AMERICAN FEDERAL CREDIT UNION", APART FROM THE MARK AS SHOWN.

THE MARK CONSISTS OF AN OPEN BOTTOM OVAL WITH TRIDENT IN CIRCLE IN MIDDLE AROUND WHICH ARE TWO WAVY LINES. LOCATED NEXT TO THE DESIGN IS THE WORD "SELFRELIANCE" BELOW WHICH ARE THE WORDS "UKRAINIAN AMERICAN FEDERAL CREDIT UNION". LOCATED BELOW THE ENGLISH WORDING IS THE CYRILLIC TRANSLATION OF THE ENGLISH WORDS ABOVE.

THE ENGLISH TRANSLATION OF THE CYRILLIC TEXT "САМОСТІЙНІСТЬ УКРАЇНСЬКО АМЕРИКАНСЬКО ЄДИНІ ПАСІБКА КРЕДИТНОЇ СПІЛНОТИ" IN THE MARK IS "SELFRELIANCE UKRAINIAN AMERICAN FEDERAL CREDIT UNION".

FOR FINANCIAL SERVICES, NAMELY, CREDIT UNIONS (U.S. CLS. 100, 101 AND 102).

FIRST USE 6-1-1997; IN COMMERCE 6-1-2001.

LAURIE MAYES, EXAMINING ATTORNEY

SN 85-276,307. V3 CAPITAL MANAGEMENT, L.P., NEW YORK, NY. FILED 3-24-2011.

V3 CAPITAL MANAGEMENT, L.P.

THE MARK CONSISTS OF STANDARD CHARACTERS WITHOUT CLAIM TO ANY PARTICULAR FONT, STYLE, SIZE, OR COLOR.

NO CLAIM IS MADE TO THE EXCLUSIVE RIGHT TO USE "CAPITAL MANAGEMENT, L.P.", APART FROM THE MARK AS SHOWN.

FOR FINANCIAL SERVICES, NAMELY, ASSET MANAGEMENT SERVICES, INVESTMENT MANAGEMENT SERVICES AND INVESTMENT ADVISORY SERVICES, ALL RENDERED IN CONNECTION WITH HEDGE FUNDS (U.S. CLS. 100, 101 AND 102).

SCOTT BIBB, EXAMINING ATTORNEY

CLASS 36—(Continued).

SN 85-276,309. V3 CAPITAL MANAGEMENT, L.P., NEW YORK, NY. FILED 3-24-2011.

V3 REALTY PARTNERS, L.P.

THE MARK CONSISTS OF STANDARD CHARACTERS WITHOUT CLAIM TO ANY PARTICULAR FONT, STYLE, SIZE, OR COLOR.

NO CLAIM IS MADE TO THE EXCLUSIVE RIGHT TO USE "REALTY PARTNERS, L.P.", APART FROM THE MARK AS SHOWN.

FOR FINANCIAL SERVICES, NAMELY, ASSET MANAGEMENT SERVICES, INVESTMENT MANAGEMENT SERVICES AND INVESTMENT ADVISORY SERVICES, ALL RENDERED IN CONNECTION WITH HEDGE FUNDS (U.S. CLS. 100, 101 AND 102).

SCOTT BIBB, EXAMINING ATTORNEY

SN 85-276,690. ROSS POWERS FOUNDATION, LONDON-DERRY, VT. FILED 3-25-2011.

LEVEL FIELD FUND

THE MARK CONSISTS OF STANDARD CHARACTERS WITHOUT CLAIM TO ANY PARTICULAR FONT, STYLE, SIZE, OR COLOR.

NO CLAIM IS MADE TO THE EXCLUSIVE RIGHT TO USE "FUND", APART FROM THE MARK AS SHOWN.

FOR CHARITABLE SERVICES, NAMELY, PROVIDING FUNDING TO SUPPORT TRAINING IN THE FIELD OF SPORTS (U.S. CLS. 100, 101 AND 102).

FIRST USE 6-16-2010; IN COMMERCE 6-16-2010.

KEVIN CORWIN, EXAMINING ATTORNEY

SN 85-276,902. DOC AUTO INSURANCE GROUP, LLC, BRADENTON, FL. FILED 3-25-2011.

DOCINS
INSURANCE

NO CLAIM IS MADE TO THE EXCLUSIVE RIGHT TO USE "INSURANCE", APART FROM THE MARK AS SHOWN.

THE MARK CONSISTS OF THE STYLIZED WORDS "DOCINS INSURANCE".

FOR INSURANCE AGENCIES (U.S. CLS. 100, 101 AND 102).

FIRST USE 1-1-2008; IN COMMERCE 1-1-2008.

JEFFERY COWARD, EXAMINING ATTORNEY

CLASS 36—(Continued).

SN 85-276,972. BELLINGHAM CORPORATION, WEST-BURY, NY. FILED 3-25-2011.

YOUR NEW REO

THE MARK CONSISTS OF STANDARD CHARACTERS WITHOUT CLAIM TO ANY PARTICULAR FONT, STYLE, SIZE, OR COLOR.

NO CLAIM IS MADE TO THE EXCLUSIVE RIGHT TO USE "REO", APART FROM THE MARK AS SHOWN.

FOR PROVIDING REAL ESTATE LISTINGS VIA THE INTERNET (U.S. CLS. 100, 101 AND 102).

HOWARD SMIGA, EXAMINING ATTORNEY

SN 85-277,038. QUEENSCLIFF PARTNERS LP, NEW YORK, NY. FILED 3-25-2011.

QUEENSCLIFF PARTNERS LP

THE MARK CONSISTS OF STANDARD CHARACTERS WITHOUT CLAIM TO ANY PARTICULAR FONT, STYLE, SIZE, OR COLOR.

NO CLAIM IS MADE TO THE EXCLUSIVE RIGHT TO USE "PARTNERS LP", APART FROM THE MARK AS SHOWN.

FOR FINANCIAL SERVICES, NAMELY, ASSET MANAGEMENT SERVICES, INVESTMENT MANAGEMENT SERVICES AND INVESTMENT ADVISORY SERVICES (U.S. CLS. 100, 101 AND 102).

DANNEAN HETZEL, EXAMINING ATTORNEY

SN 85-277,282. CAPSTONE DEVELOPMENT CORP., BIRMINGHAM, AL. FILED 3-25-2011.



OWNER OF U.S. REG. NOS. 3,467,170, 3,589,825 AND OTHERS.

NO CLAIM IS MADE TO THE EXCLUSIVE RIGHT TO USE "THE COTTAGES OF STATE COLLEGE," "EST.," "2012" AND "COMMUNITY", APART FROM THE MARK AS SHOWN.

THE MARK CONSISTS OF AN OVAL CONTAINING THE FRONT VIEW OF A 2-STORY HOUSE AND THE STYLIZED WORDS, "THE COTTAGES OF STATE COLLEGE A FRONT PORCH COMMUNITY EST. 2012".

FOR REAL ESTATE SERVICES, NAMELY, MANAGEMENT AND RENTAL OF STUDENT HOUSING FOR COLLEGE STUDENTS (U.S. CLS. 100, 101 AND 102).

AMY C. KEAN, EXAMINING ATTORNEY

CLASS 36—(Continued).

SN 85-277,293. CAPSTONE DEVELOPMENT CORP., BIRMINGHAM, AL. FILED 3-25-2011.



OWNER OF U.S. REG. NOS. 3,467,170, 3,589,825 AND OTHERS.

NO CLAIM IS MADE TO THE EXCLUSIVE RIGHT TO USE "THE COTTAGES OF DURHAM," "EST.," "2011" AND "COMMUNITY", APART FROM THE MARK AS SHOWN.

THE MARK CONSISTS OF AN OVAL CONTAINING THE FRONT VIEW OF A 2-STORY HOUSE AND THE STYLIZED WORDS, "THE COTTAGES OF DURHAM A FRONT PORCH COMMUNITY EST. 2011".

FOR REAL ESTATE SERVICES, NAMELY, MANAGEMENT AND RENTAL OF STUDENT HOUSING FOR COLLEGE STUDENTS (U.S. CLS. 100, 101 AND 102).

AMY C. KEAN, EXAMINING ATTORNEY

CLASS 36—(Continued).

SN 85-277,320. CAPSTONE DEVELOPMENT CORP., BIRMINGHAM, AL. FILED 3-25-2011.



OWNER OF U.S. REG. NOS. 3,467,170, 3,589,825 AND OTHERS.

NO CLAIM IS MADE TO THE EXCLUSIVE RIGHT TO USE "THE COTTAGES OF BLOOMINGTON," "EST.," "2012" AND "COMMUNITY", APART FROM THE MARK AS SHOWN.

THE MARK CONSISTS OF AN OVAL CONTAINING THE FRONT VIEW OF A 2-STORY HOUSE AND THE STYLIZED WORDS, "THE COTTAGES OF BLOOMINGTON A FRONT PORCH COMMUNITY EST. 2012".

FOR REAL ESTATE SERVICES, NAMELY, MANAGEMENT AND RENTAL OF STUDENT HOUSING FOR COLLEGE STUDENTS (U.S. CLS. 100, 101 AND 102).

AMY C. KEAN, EXAMINING ATTORNEY

SN 85-277,309. CAPSTONE DEVELOPMENT CORP., BIRMINGHAM, AL. FILED 3-25-2011.



OWNER OF U.S. REG. NOS. 3,467,170, 3,589,825 AND OTHERS.

NO CLAIM IS MADE TO THE EXCLUSIVE RIGHT TO USE "THE LODGES OF TALLAHASSEE," "EST.," "2012" AND "COMMUNITY", APART FROM THE MARK AS SHOWN.

THE MARK CONSISTS OF AN OVAL CONTAINING THE FRONT VIEW OF A 2-STORY HOUSE AND THE STYLIZED WORDS, "THE LODGES OF TALLAHASSEE A FRONT PORCH COMMUNITY EST. 2012".

FOR REAL ESTATE SERVICES, NAMELY, MANAGEMENT AND RENTAL OF STUDENT HOUSING FOR COLLEGE STUDENTS (U.S. CLS. 100, 101 AND 102).

AMY C. KEAN, EXAMINING ATTORNEY

SN 85-277,331. CAPSTONE DEVELOPMENT CORP., BIRMINGHAM, AL. FILED 3-25-2011.



OWNER OF U.S. REG. NOS. 3,467,170, 3,589,825 AND OTHERS.

NO CLAIM IS MADE TO THE EXCLUSIVE RIGHT TO USE "THE COTTAGES OF COLLEGE STATION," "EST.," "2011" AND "COMMUNITY", APART FROM THE MARK AS SHOWN.

THE MARK CONSISTS OF AN OVAL CONTAINING THE FRONT VIEW OF A 2-STORY HOUSE AND THE STYLIZED WORDS, "THE COTTAGES OF COLLEGE STATION A FRONT PORCH COMMUNITY EST 2011".

FOR REAL ESTATE SERVICES, NAMELY, MANAGEMENT AND RENTAL OF STUDENT HOUSING FOR COLLEGE STUDENTS (U.S. CLS. 100, 101 AND 102).

AMY C. KEAN, EXAMINING ATTORNEY

CLASS 36—(Continued).

SN 85-277,339. CAPSTONE DEVELOPMENT CORP., BIRMINGHAM, AL. FILED 3-25-2011.



OWNER OF U.S. REG. NOS. 3,467,170, 3,589,825 AND OTHERS.

NO CLAIM IS MADE TO THE EXCLUSIVE RIGHT TO USE "THE COTTAGES OF JACKSONVILLE," "EST.," "2012" AND "COMMUNITY", APART FROM THE MARK AS SHOWN.

THE MARK CONSISTS OF AN OVAL CONTAINING THE FRONT VIEW OF A 2-STORY HOUSE AND THE STYLIZED WORDS, "THE COTTAGES OF JACKSONVILLE A FRONT PORCH COMMUNITY EST. 2012".

FOR REAL ESTATE SERVICES, NAMELY, MANAGEMENT AND RENTAL OF STUDENT HOUSING FOR COLLEGE STUDENTS (U.S. CLS. 100, 101 AND 102).
AMY C. KEAN, EXAMINING ATTORNEY

CLASS 36—(Continued).

SN 85-277,490. BLESSED HOMES LLC, SAINT ALBANS, NY. FILED 3-25-2011.



NO CLAIM IS MADE TO THE EXCLUSIVE RIGHT TO USE "HOMES", APART FROM THE MARK AS SHOWN.

THE MARK CONSISTS OF THE WORDS "BLESSED HOMES" INTERSECTING WITH THE GRAPHIC IMAGE OF A HOUSE DISPLAYING THE ROOF AND FLOOR. THE BACKGROUND OF THE MARK IS TRANSPARENT.

FOR REAL ESTATE AGENCIES; REAL ESTATE BROKERAGE FOR SALE AND RENTAL OF LAND, HOMES, APARTMENTS, CONDOMINIUMS, COOPERATIVE UNITS, BUILDINGS AND OFFICES (U.S. CLS. 100, 101 AND 102).

FIRST USE 2-25-2011; IN COMMERCE 2-25-2011.
ANDREA HACK, EXAMINING ATTORNEY

SN 85-277,344. SUSSEX BANCORP, FRANKLIN, NJ. FILED 3-25-2011.



NO CLAIM IS MADE TO THE EXCLUSIVE RIGHT TO USE "SUSSEX BANK", APART FROM THE MARK AS SHOWN.

THE MARK CONSISTS OF A CIRCLE WITH BARS FORMING THE IMAGE OF A BUILDING PRECEDING THE WORDS "SUSSEX BANK".

FOR BANKING SERVICES (U.S. CLS. 100, 101 AND 102).
FIRST USE 10-1-2001; IN COMMERCE 10-1-2001.
SUE LAWRENCE, EXAMINING ATTORNEY

SN 85-279,046. TOTAL RESOURCES INTERNATIONAL, WALNUT, CA. FILED 3-28-2011.

GIVE A PENNY...FEED THE HUNGRY

THE MARK CONSISTS OF STANDARD CHARACTERS WITHOUT CLAIM TO ANY PARTICULAR FONT, STYLE, SIZE, OR COLOR.

FOR CHARITABLE FUNDRAISING SERVICES, NAMELY, RAISING MONEY FOR FEEDING THE HUNGRY BY DISTRIBUTING A VARIETY OF HOUSEHOLD ITEMS TO BE SOLD BY OTHERS (U.S. CLS. 100, 101 AND 102).

JAMES LOVELACE, EXAMINING ATTORNEY

CLASS 36—(Continued).

SN 85-279,054. DI PIAZZA, GIACOMO, SOUTH HACKENSACK, NJ. FILED 3-28-2011.



NO CLAIM IS MADE TO THE EXCLUSIVE RIGHT TO USE "FINANCIAL", APART FROM THE MARK AS SHOWN.

THE MARK CONSISTS OF A SEAL WITH THE LETTER "B" IN THE MIDDLE. AROUND THE INNER BORDER OF THE SEAL IS THE STYLIZED TEXT "BOND STREET FINANCIAL".

FOR FINANCIAL AND INVESTMENT SERVICES, NAMELY, MANAGEMENT AND BROKERAGE IN THE FIELDS OF STOCKS, BONDS, OPTIONS, COMMODITIES, FUTURES AND OTHER SECURITIES, AND THE INVESTMENT OF FUNDS OF OTHERS; INSURANCE AGENCY AND BROKERAGE (U.S. CLS. 100, 101 AND 102).

FIRST USE 10-4-2004; IN COMMERCE 10-4-2004.
SCOTT BIBB, EXAMINING ATTORNEY

SN 85-279,233. VETRADO PTE. LTD., 101A UPPER CROSS ST, SINGAPORE, FILED 3-28-2011.

VETRADO

THE MARK CONSISTS OF STANDARD CHARACTERS WITHOUT CLAIM TO ANY PARTICULAR FONT, STYLE, SIZE, OR COLOR.

THE WORDING "VETRADO" HAS NO MEANING IN A FOREIGN LANGUAGE.

FOR FINANCIAL SERVICES, NAMELY, ELECTRONIC FUNDS TRANSFER VIA ELECTRONIC COMMUNICATIONS NETWORKS; CLEARING AND RECONCILING FINANCIAL TRANSACTIONS VIA ELECTRONIC COMMUNICATIONS NETWORKS; PROVIDING PAYMENT AND FINANCIAL SERVICES, NAMELY, PROCESSING AND TRANSMISSION OF BILLS AND PAYMENTS THEREOF; BILL PAYMENT SERVICES WITH GUARANTEED PAYMENT DELIVERY ALL CONDUCTED VIA A GLOBAL COMMUNICATIONS NETWORK (U.S. CLS. 100, 101 AND 102).

DAVID C. REIHNER, EXAMINING ATTORNEY

CLASS 36—(Continued).

SN 85-280,888. SCOTT SHERWOOD, GOODLAND, FL. FILED 3-30-2011.

AATRIA

THE MARK CONSISTS OF STANDARD CHARACTERS WITHOUT CLAIM TO ANY PARTICULAR FONT, STYLE, SIZE, OR COLOR.

FOR ELECTRONIC FINANCIAL TRADING SERVICES; FINANCIAL ADVICE AND CONSULTANCY SERVICES; FINANCIAL AND INVESTMENT SERVICES, NAMELY, MANAGEMENT AND BROKERAGE IN THE FIELDS OF STOCKS, BONDS, OPTIONS, COMMODITIES, FUTURES AND OTHER SECURITIES, AND THE INVESTMENT OF FUNDS OF OTHERS; FINANCIAL EVALUATION, TRACKING, ANALYSIS, FORECASTING, CONSULTANCY, ADVISORY AND RESEARCH SERVICES RELATING TO SECURITIES AND OTHER FINANCIAL INSTRUMENTS; FINANCIAL INVESTMENT BROKERAGE SERVICES; FINANCIAL PLANNING AND INVESTMENT ADVISORY SERVICES; FINANCIAL SERVICES, NAMELY, ASSISTING OTHERS WITH THE COMPLETION OF FINANCIAL TRANSACTIONS FOR STOCKS, BONDS, SECURITIES AND EQUITIES; FINANCIAL SERVICES, NAMELY, BROKER/DEALER SERVICES ON SECURITIES EXCHANGES AND OVER-THE-COUNTER MARKETS; FINANCIAL SERVICES, NAMELY, INVESTMENT ADVICE, INVESTMENT MANAGEMENT, INVESTMENT CONSULTATION AND INVESTMENT OF FUNDS FOR OTHERS, INCLUDING PRIVATE AND PUBLIC EQUITY AND DEBT INVESTMENT SERVICES; FINANCIAL SERVICES, NAMELY, PROVIDING AN INVESTMENT OPTION AVAILABLE FOR VARIABLE ANNUITY AND VARIABLE LIFE INSURANCE PRODUCTS; FINANCIAL SERVICES, NAMELY, PROVIDING ON-LINE STORED VALUE ACCOUNTS IN AN ELECTRONIC ENVIRONMENT; FINANCIAL SERVICES, NAMELY, THE TRADING OF FINANCIAL INSTRUMENTS, SECURITIES, SHARES, OPTIONS AND OTHER DERIVATIVE PRODUCTS; INSURANCE AND FINANCIAL INFORMATION AND CONSULTANCY SERVICES; ON-LINE FINANCIAL PLANNING SERVICES; PROVIDING FINANCIAL SERVICES WITH RESPECT TO SECURITIES AND OTHER FINANCIAL INSTRUMENTS AND PRODUCTS, NAMELY, TRADING OF AND INVESTMENTS IN SECURITIES AND FINANCIAL INSTRUMENTS AND PRODUCTS FOR OTHERS (U.S. CLS. 100, 101 AND 102).

FIRST USE 2-26-2010; IN COMMERCE 2-26-2010.
REBECCA GILBERT, EXAMINING ATTORNEY

CLASS 36—(Continued).

SN 85-283,374. DANTZLER, JASON, DBA DESIGNER FREE, ALBANY, NY. FILED 4-1-2011.



DESIGNER FREE

THE MARK CONSISTS OF A HIGHLY STYLIZED LETTER "J" AND THE LITERAL ELEMENT "DESIGNER FREE" APPEARING BELOW THE STYLIZED "J". THERE IS NO COLOR BACKGROUND CLAIMED AS A FEATURE OF THE MARK.

FOR FINANCIAL ADVISORY AND CONSULTANCY SERVICES, NAMELY, THE CREATION OF PERSONALIZED STRATEGIES TO ACHIEVE FINANCIAL INDEPENDENCE (U.S. CLS. 100, 101 AND 102).

FIRST USE 10-1-1985; IN COMMERCE 12-1-2010.
THOMAS MANOR, EXAMINING ATTORNEY

SN 85-283,475. INVESCO HOLDING COMPANY LIMITED, ATLANTA, GA. FILED 4-1-2011.

**EXPLORE INTENTIONAL
INVESTING WITH INVESCO**

THE MARK CONSISTS OF STANDARD CHARACTERS WITHOUT CLAIM TO ANY PARTICULAR FONT, STYLE, SIZE, OR COLOR.

OWNER OF U.S. REG. NOS. 1,825,441, 3,877,427 AND OTHERS.

FOR FINANCIAL AND INVESTMENT SERVICES, NAMELY, MANAGEMENT AND BROKERAGE IN THE FIELDS OF STOCKS, BONDS, OPTIONS, COMMODITIES, FUTURES AND OTHER SECURITIES, AND INVESTMENT OF FUNDS OF OTHERS; TRANSFER AGENCY SERVICES RENDERED TO THE ISSUERS OF INVESTMENT SECURITIES; FINANCIAL ANALYSIS, MANAGEMENT, CONSULTING AND ADVISORY SERVICES; FUND INVESTMENT, FINANCIAL ACCOUNT REPORTING SERVICES RELATING TO INVESTMENT FUNDS; ELECTRONIC FUNDS TRANSFER; FINANCIAL INFORMATION AND EVALUATION SERVICES; SAVINGS AND LOAN SERVICES; INDIVIDUAL SAVINGS ACCOUNT SERVICES; CAPITAL INVESTMENT SERVICES; FINANCIAL TRANSACTION SERVICES, NAMELY, TRADING OF FINANCIAL INSTRUMENTS; INVESTMENT SERVICES, NAMELY, ASSET MANAGEMENT; FINANCIAL, SECURITIES AND COMMODITIES EXCHANGE SERVICES; INVESTMENT ANALYSIS; REAL ESTATE MANAGEMENT; RENTAL OF OFFICE SPACE; RETIREMENT PAYMENT SERVICES, NAMELY, INVESTMENT MANAGEMENT OF AND DISTRIBUTION OF ANNUITIES; AND TRUSTEESHIP REPRESENTATIVES (U.S. CLS. 100, 101 AND 102).

LESLEY LAMOTHE, EXAMINING ATTORNEY

CLASS 36—(Continued).

SN 85-284,566. ELEGANTREE LTD., SINGAPORE, SINGAPORE, FILED 4-2-2011.

ELEGANTREE

THE MARK CONSISTS OF STANDARD CHARACTERS WITHOUT CLAIM TO ANY PARTICULAR FONT, STYLE, SIZE, OR COLOR.

FOR FINANCIAL ANALYSIS AND INFORMATION; CAPITAL INVESTMENTS CONSULTANCY; INFORMATION, ADVISORY, CONSULTANCY AND RESEARCH SERVICES RELATING TO FINANCE AND INVESTMENTS; FINANCIAL ADVICE AND CONSULTANCY SERVICES; INVESTMENT CONSULTANCY; FINANCIAL MANAGEMENT; FISCAL VALUATIONS; FUND INVESTMENTS; OPERATE AND MANAGE MUTUAL FUNDS (U.S. CLS. 100, 101 AND 102).

MARILYN IZZI, EXAMINING ATTORNEY

SN 85-286,389. TRIPLETT, ROBERT M & ARCHIE, LINDA, THOUSAND OAKS, CA. FILED 4-5-2011.

IF YOU'RE 50+ CALL ON US!

THE MARK CONSISTS OF STANDARD CHARACTERS WITHOUT CLAIM TO ANY PARTICULAR FONT, STYLE, SIZE, OR COLOR.

FOR RESIDENTIAL REAL ESTATE AGENCY SERVICES (U.S. CLS. 100, 101 AND 102).

FIRST USE 2-1-2011; IN COMMERCE 2-1-2011.

KIMBERLY PERRY, EXAMINING ATTORNEY

SN 85-287,306. BERTRAM CAPITAL MANAGEMENT LLC, SAN MATEO, CA. FILED 4-6-2011.

UNLOCK YOUR POTENTIAL

THE MARK CONSISTS OF STANDARD CHARACTERS WITHOUT CLAIM TO ANY PARTICULAR FONT, STYLE, SIZE, OR COLOR.

FOR FINANCIAL INVESTMENT SERVICES, NAMELY, PROVIDING VENTURE CAPITAL FUNDING SERVICES TO EMERGING COMPANIES, FINANCIAL PLANNING AND CONSULTATION, INVESTMENT MANAGEMENT OF EQUITY SHARES, FINANCING SERVICES, FINANCIAL ANALYSIS, FINANCIAL MANAGEMENT, FUNDS INVESTMENTS, MANAGEMENT OF CAPITAL INVESTMENTS, ASSET MANAGEMENT, INVESTMENT ANALYSIS (U.S. CLS. 100, 101 AND 102).

FIRST USE 2-25-2007; IN COMMERCE 2-25-2007.

TARA PATE, EXAMINING ATTORNEY

CLASS 36—(Continued).

SN 85-288,566. ROH, SCOTT A, NEENAH, WI. FILED 4-7-2011.

THE WATER'S JUST RIGHT!

THE MARK CONSISTS OF STANDARD CHARACTERS WITHOUT CLAIM TO ANY PARTICULAR FONT, STYLE, SIZE, OR COLOR.

FOR RESIDENTIAL REAL ESTATE AGENCY SERVICES (U.S. CLS. 100, 101 AND 102).

FIRST USE 5-9-2008; IN COMMERCE 5-9-2008.

KATHLEEN M. VANSTON, EXAMINING ATTORNEY

SN 85-290,168. OPPENHEIMERFUNDS, INC., NEW YORK, NY. FILED 4-8-2011.

GLOMESTIC

THE MARK CONSISTS OF STANDARD CHARACTERS WITHOUT CLAIM TO ANY PARTICULAR FONT, STYLE, SIZE, OR COLOR.

FOR INVESTMENT SERVICES, NAMELY, FORMULATION OF INVESTMENT STRATEGIES (U.S. CLS. 100, 101 AND 102).

DOMINICK J. SALEMI, EXAMINING ATTORNEY

SN 85-290,768. BRINK PROPERTY MANAGEMENT, INC., BELLEVUE, WA. FILED 4-8-2011.

BRINK PROPERTY MANAGEMENT

THE MARK CONSISTS OF STANDARD CHARACTERS WITHOUT CLAIM TO ANY PARTICULAR FONT, STYLE, SIZE, OR COLOR.

NO CLAIM IS MADE TO THE EXCLUSIVE RIGHT TO USE "PROPERTY MANAGEMENT", APART FROM THE MARK AS SHOWN.

FOR REAL ESTATE SERVICE, NAMELY, RENTAL PROPERTY MANAGEMENT; REAL ESTATE SERVICES, NAMELY, PROPERTY MANAGEMENT SERVICES FOR CONDOMINIUM ASSOCIATIONS, HOMEOWNER ASSOCIATIONS AND APARTMENT BUILDINGS; REAL ESTATE SERVICES, NAMELY, RENTAL, BROKERAGE, LEASING AND MANAGEMENT OF COMMERCIAL PROPERTY, OFFICES AND OFFICE SPACE (U.S. CLS. 100, 101 AND 102).

FIRST USE 5-31-1996; IN COMMERCE 5-31-1996.

THEODORE MCBRIDE, EXAMINING ATTORNEY

CLASS 36—(Continued).

SN 85-290,874. DOTY, CHAD, RICHMOND, VA. FILED 4-8-2011.

ACHIEVE PERMANENT WEALTH

THE MARK CONSISTS OF STANDARD CHARACTERS WITHOUT CLAIM TO ANY PARTICULAR FONT, STYLE, SIZE, OR COLOR.

FOR REAL ESTATE AGENCIES, REAL ESTATE BROKERAGE, REAL ESTATE MANAGEMENT (U.S. CLS. 100, 101 AND 102).

JESSICA A. POWERS, EXAMINING ATTORNEY

SN 85-291,091. NORTHWEST REAL ESTATE CAPITAL CORP., BOISE, ID. FILED 4-9-2011.



THE COLOR(S) BLUE AND ORANGE IS/ARE CLAIMED AS A FEATURE OF THE MARK.

THE MARK CONSISTS OF TWO ARROW-SHAPED DESIGNS WITH ONE SIDE OF EACH ARROW SHAPE ELONGATED. THE BLUE ARROW ON THE LEFT SIDE OF THE DESIGN IS POINTED UPWARD WITH THE LEFT SIDE ELONGATED. THE ORANGE ARROW TO THE RIGHT OF THE BLUE ARROW IS POINTED DOWNWARD WITH THE RIGHT SIDE ELONGATED.

FOR REAL ESTATE SERVICE, NAMELY, RENTAL PROPERTY MANAGEMENT (U.S. CLS. 100, 101 AND 102).

FIRST USE 10-6-2010; IN COMMERCE 10-6-2010.

HENRY S. ZAK, EXAMINING ATTORNEY

CLASS 36—(Continued).

SN 85-291,601. SCHWARTZ, JAMIE, UPPER BLACK EDDY, PA. FILED 4-11-2011.



THE NAME "JAMIE SCHWARTZ" IDENTIFIES A LIVING INDIVIDUAL WHOSE CONSENT IS OF RECORD.

THE MARK CONSISTS OF THE STYLIZED WORDING "ART IS THE PITS" ABOVE THE STYLIZED WORDING "ARTSY BULLIES BY JAMIE SCHWARTZ". THE LOOP IN THE LETTER "P" IN "PITS" CONTAINS A GRAPHIC OF A PAW PRINT. BELOW THE TEXT IS A GRAPHIC OF TWO PIT BULLS.

FOR CHARITABLE FUNDRAISING SERVICES BY MEANS OF SELLING NOTE CARDS, ART PRINTS, BUTTONS, HANDBAGS, T-SHIRTS, AND VARIOUS ARTWORK TO RAISE FUNDS FOR ANIMAL RIGHTS AND ANIMAL ADVOCACY (U.S. CLS. 100, 101 AND 102).

FIRST USE 8-24-2010; IN COMMERCE 9-7-2010.
ALYSSA STEEL, EXAMINING ATTORNEY

SN 85-291,721. BEDEL FINANCIAL CONSULTING, INC., INDIANAPOLIS, IN. FILED 4-11-2011.

Generation NeXt

THE MARK CONSISTS OF STANDARD CHARACTERS WITHOUT CLAIM TO ANY PARTICULAR FONT, STYLE, SIZE, OR COLOR.

FOR FINANCIAL PLANNING; INVESTMENT ADVISORY SERVICES; INVESTMENT MANAGEMENT (U.S. CLS. 100, 101 AND 102).

SUSAN STIGLITZ, EXAMINING ATTORNEY

CLASS 36—(Continued).

SN 85-291,724. BEDEL FINANCIAL CONSULTING, INC., INDIANAPOLIS, IN. FILED 4-11-2011.

Plan - Invest - Achieve

THE MARK CONSISTS OF STANDARD CHARACTERS WITHOUT CLAIM TO ANY PARTICULAR FONT, STYLE, SIZE, OR COLOR.

FOR FINANCIAL PLANNING; INVESTMENT ADVISORY SERVICES; INVESTMENT MANAGEMENT (U.S. CLS. 100, 101 AND 102).

SUSAN STIGLITZ, EXAMINING ATTORNEY

SN 85-291,958. WELLNESS FINANCIAL ADVISORS, LLC, BRENTWOOD, TN. FILED 4-11-2011.



THE MARK CONSISTS OF A STYLIZED LETTER "W" IN A CIRCLE.

FOR FINANCIAL ADVICE; FINANCIAL CONSULTANCY AND INSURANCE CONSULTANCY; FINANCIAL PLANNING CONSULTATION (U.S. CLS. 100, 101 AND 102).

JULIE WATSON, EXAMINING ATTORNEY

SN 85-292,121. NASSAU, MARLA JAFFE, CORAL SPRINGS, FL. FILED 4-11-2011.

HOPPING 4 THE CURE

THE MARK CONSISTS OF STANDARD CHARACTERS WITHOUT CLAIM TO ANY PARTICULAR FONT, STYLE, SIZE, OR COLOR.

NO CLAIM IS MADE TO THE EXCLUSIVE RIGHT TO USE "HOPPING", APART FROM THE MARK AS SHOWN. FOR CHARITABLE FUNDRAISING SERVICES; CHARITABLE FUNDRAISING SERVICES BY MEANS OF ORGANIZING AND CONDUCTING SPECIAL EVENTS (U.S. CLS. 100, 101 AND 102).

FIRST USE 9-12-2010; IN COMMERCE 11-2-2010.
SETH A. RAPPAPORT, EXAMINING ATTORNEY

CLASS 36—(Continued).

SN 85-292,201. VOGOGO, INC., CALGARY - ALBERTA, CANADA, FILED 4-11-2011.



THE COLOR(S) DARK GREY AND ORANGE IS/ARE CLAIMED AS A FEATURE OF THE MARK.

THE MARK CONSISTS OF THE WORD "VOGOGO" IN DARK GREY IN LOWER CASE AND A STYLIZED COLON IN THE COLOR ORANGE.

FOR ELECTRONIC BILL PAYMENTS, NAMELY, ELECTRONIC FUNDS TRANSFER, ELECTRONIC PROCESSING AND TRANSMISSION OF BILL PAYMENT DATA; AND CREDIT AND DEBIT CARD SERVICES (U.S. CLS. 100, 101 AND 102).

LINDA E. BLOHM, EXAMINING ATTORNEY

SN 85-292,232. PIKE PLACE MARKET PRESERVATION AND DEVELOPMENT AUTHORITY, SEATTLE, WA. FILED 4-11-2011.



OWNER OF U.S. REG. NOS. 2,233,478, 3,189,234 AND OTHERS.

NO CLAIM IS MADE TO THE EXCLUSIVE RIGHT TO USE "SEATTLE'S," "SINCE 1907," "PIKE PLACE" AND "MARKET", APART FROM THE MARK AS SHOWN.

THE MARK CONSISTS OF A BANNER WITH THE WORDS "SEATTLE'S OWN SINCE 1907" WRITTEN ON IT, OVERLAID WITH THE MARKET CLOCK SET AT 2:07, ABOVE THE WORDS "PIKE PLACE MARKET" AND A HORIZONTAL LINE SEPARATING THE WORDS "PIKE PLACE" AND "MARKET".

FOR LEASING AND MANAGEMENT OF BUILDINGS AND SPACE FOR A VARIETY OF RETAIL SHOPS, FARMERS' AND CRAFTS MARKETS, RESTAURANTS, BREWERIES, BAKERIES, OFFICES, RETIREMENT AND ASSISTED LIVING FACILITIES, MEDICAL CLINICS, FOOD BANKS, APARTMENTS AND HOTELS (U.S. CLS. 100, 101 AND 102).

FIRST USE 12-31-2007; IN COMMERCE 12-31-2007.
DEIRDRE ROBERTSON, EXAMINING ATTORNEY

CLASS 36—(Continued).

SN 85-292,270. MERITUS CAPITAL, INC., SEBASTOPOL, CA. FILED 4-11-2011.



THE MARK CONSISTS OF STANDARD CHARACTERS WITHOUT CLAIM TO ANY PARTICULAR FONT, STYLE, SIZE, OR COLOR.

FOR FINANCING AND INSURANCE CLAIM MANAGEMENT SERVICES TO MEDICAL AND HEALTH-CARE PROVIDERS (U.S. CLS. 100, 101 AND 102).

FIRST USE 4-1-2011; IN COMMERCE 4-1-2011.

LAURIE KAUFMAN, EXAMINING ATTORNEY

SN 85-292,487. COMPASS FINANCIAL PARTNERS, LLC, GREENSBORO, NC. FILED 4-12-2011.



THE MARK CONSISTS OF STANDARD CHARACTERS WITHOUT CLAIM TO ANY PARTICULAR FONT, STYLE, SIZE, OR COLOR.

FOR FINANCIAL PLANNING FOR RETIREMENT (U.S. CLS. 100, 101 AND 102).

MELISSA VALLILLO, EXAMINING ATTORNEY

SN 85-292,564. ALABAMA ACQUISITION CORP., ATLANTA, GA. FILED 4-12-2011.

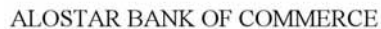

THE MARK CONSISTS OF STANDARD CHARACTERS WITHOUT CLAIM TO ANY PARTICULAR FONT, STYLE, SIZE, OR COLOR.

NO CLAIM IS MADE TO THE EXCLUSIVE RIGHT TO USE "BANK OF COMMERCE", APART FROM THE MARK AS SHOWN.

FOR BANKING SERVICES (U.S. CLS. 100, 101 AND 102).

ELLEN B. AWRICH, EXAMINING ATTORNEY

CLASS 36—(Continued).

SN 85-292,593. FRIEDLANDER GROUP, INC., PURCHASE, NY. FILED 4-12-2011.

CULTURE OF CARING

THE MARK CONSISTS OF STANDARD CHARACTERS WITHOUT CLAIM TO ANY PARTICULAR FONT, STYLE, SIZE, OR COLOR.

FOR PROVIDING INFORMATION IN THE FIELD OF WORKERS' COMPENSATION (U.S. CLS. 100, 101 AND 102).

JASON BLAIR, EXAMINING ATTORNEY

SN 85-292,760. BELLWETHER COMMUNITY CREDIT UNION, MANCHESTER, NH. FILED 4-12-2011.



OWNER OF U.S. REG. NOS. 3,172,412 AND 3,172,413.
NO CLAIM IS MADE TO THE EXCLUSIVE RIGHT TO USE "COMMUNITY CREDIT UNION", APART FROM THE MARK AS SHOWN.

THE COLOR(S) BLUE AND GREEN IS/ARE CLAIMED AS A FEATURE OF THE MARK.

THE MARK CONSISTS OF THREE ARCHES THAT GET PROGRESSIVELY LARGER FROM LEFT TO RIGHT, THE FIRST TWO ARCHES COLORED GREEN AND THE THIRD BLUE; OVER THE BLOCK LETTER WORD "BELLWETHER" IN BLUE; OVER THE BLOCK LETTER WORDS "COMMUNITY CREDIT UNION" IN GREEN; OVER THE WORDS "WHERE EASY ADDS UP." PRESENTED IN A SCRIPT FONT IN BLUE.

FOR CREDIT UNION SERVICES (U.S. CLS. 100, 101 AND 102).

LAURA KOVALSKY, EXAMINING ATTORNEY

CLASS 36—(Continued).

SN 85-293,130. ALL RISKS, LTD., COCKEYSVILLE, MD. FILED 4-12-2011.

QuickComp

OWNER OF U.S. REG. NOS. 3,427,512 AND 3,677,271.
THE MARK CONSISTS OF THE WORDS QUICK AND COMP, WITH THE WORD COMP PORTRAYED UNDER THE WORD QUICK AND SHARING THE LETTER "C" WITH THE WORD QUICK.

FOR INSURANCE UNDERWRITING IN THE FIELD OF WORKERS COMPENSATION COVERAGE OFFERED THROUGH INDEPENDENT RETAIL INSURANCE AGENTS (U.S. CLS. 100, 101 AND 102).

FIRST USE 2-1-2008; IN COMMERCE 2-1-2008.

GRETTA YAO, EXAMINING ATTORNEY

SN 85-293,273. FUTURENEST, INC., ZIONSVILLE, IN. FILED 4-12-2011.

Your Plan, Your Future

THE MARK CONSISTS OF STANDARD CHARACTERS WITHOUT CLAIM TO ANY PARTICULAR FONT, STYLE, SIZE, OR COLOR.

FOR FINANCIAL PLANNING; FINANCIAL PLANNING CONSULTATION (U.S. CLS. 100, 101 AND 102).

FIRST USE 2-1-2011; IN COMMERCE 2-21-2011.

HANNO RITTNER, EXAMINING ATTORNEY

SN 85-293,415. CHARITYMOBI TECHNOLOGY TRUST FUND, SANDY SPRINGS, GA. FILED 4-12-2011.

CharityMobi
HAPPY TO HELP

THE MARK CONSISTS OF THE WORDING CHARITY-MOBI WRITTEN IN TWO DIFFERENT STYLES OF FONT, SPECIFICALLY THE "CHARITY" WORDING IS DISPLAYED IN A HANDWRITTEN STYLIZED FONT AND "MOBI" APPEARS IN A BOLD, TRADITIONAL FONT WITH THE "I" FEATURING A BEATING HEART DESIGN AND THE WORDING HAPPY TO HELP APPEARING UNDERNEATH "MOBI" IN A SMALLER, ALL-CAPS TRADITIONAL FONT.

FOR CHARITABLE FUNDRAISING SERVICES (U.S. CLS. 100, 101 AND 102).

FIRST USE 3-9-2011; IN COMMERCE 3-9-2011.

PATRICIA EVANKO, EXAMINING ATTORNEY

CLASS 36—(Continued).

SN 85-293,557. CONSOLIDATED ASSET RECOVERY SYSTEMS, INC., RALEIGH, NC. FILED 4-13-2011.



THE COLOR(S) ORANGE AND WHITE IS/ARE CLAIMED AS A FEATURE OF THE MARK.

THE MARK CONSISTS OF AN ORANGE BOX CONTAINING A LARGE WHITE STYLISTIC LETTER "C"; WITH A SECOND SMALLER WHITE LETTER "C" INSIDE THE LARGER "C", TERMINATING IN A WHITE ARROWHEAD EXTENDING OUTSIDE THE BOX, OUTLINED IN ORANGE.

FOR DEBT RECOVERY AND COLLECTION AGENCIES; DEBT RECOVERY SERVICES; REPOSSESSION SERVICES IN THE NATURE OF DEBT COLLECTION (U.S. CLS. 100, 101 AND 102).

FIRST USE 2-1-2005; IN COMMERCE 2-1-2005.
KEVIN DINALLO, EXAMINING ATTORNEY

SN 85-293,741. CUTWATER HOLDINGS, LLC, ARMONK, NY. FILED 4-13-2011.



OWNER OF U.S. REG. NO. 3,874,700.
NO CLAIM IS MADE TO THE EXCLUSIVE RIGHT TO USE "ASSET MANAGEMENT", APART FROM THE MARK AS SHOWN.

THE MARK CONSISTS OF THE WORD "CUTWATER", IN LARGE UPPER CASE LETTERS, TO THE LEFT OF AN ARC-SHAPED LINE OF SOLID CIRCLES WHICH VARY IN SIZE FROM SMALL TO LARGE TO SMALL; TO THE RIGHT OF THE CIRCLES ARE THE WORDS "ASSET MANAGEMENT" IN SMALL UPPERCASE LETTERS.

FOR INVESTMENT MANAGEMENT SERVICES; FINANCIAL ASSET MANAGEMENT SERVICES; INVESTMENT ADVISORY SERVICES; INVESTMENT BROKERAGE SERVICES; INVESTMENT CONSULTATION SERVICES; PROVIDING FINANCIAL INVESTMENT ADMINISTRATION AND SHAREHOLDER SERVICES TO LOCAL GOVERNMENT INVESTMENT PROGRAMS, NAMELY, ACCOUNT INFORMATION, DATA, MARKET DATA, SHARE PRICE MOVEMENT AND SECURITIES REPORTING (U.S. CLS. 100, 101 AND 102).

FIRST USE 2-8-2010; IN COMMERCE 2-8-2010.
SETH A. RAPPAPORT, EXAMINING ATTORNEY

CLASS 36—(Continued).

SN 85-293,942. PATELCO CREDIT UNION, PLEASANTON, CA. FILED 4-13-2011.

InvestDaily

THE MARK CONSISTS OF STANDARD CHARACTERS WITHOUT CLAIM TO ANY PARTICULAR FONT, STYLE, SIZE, OR COLOR.

FOR FINANCIAL INVESTMENT BROKERAGE SERVICES; INFORMATION, ADVISORY, CONSULTANCY AND RESEARCH SERVICES RELATING TO FINANCE AND INVESTMENTS; INVESTMENT ADVISORY SERVICES; INVESTMENT CONSULTANCY; INVESTMENT MANAGEMENT; INVESTMENT OF FUNDS FOR OTHERS (U.S. CLS. 100, 101 AND 102).

DAVID C. REIHNER, EXAMINING ATTORNEY

SN 85-294,058. DSS SERVICES, LLC, NEW YORK, NY. FILED 4-13-2011.

WE CAN SATISFY ALL YOUR REAL ESTATE NEEDS

THE MARK CONSISTS OF STANDARD CHARACTERS WITHOUT CLAIM TO ANY PARTICULAR FONT, STYLE, SIZE, OR COLOR.

FOR REAL ESTATE AGENCIES (U.S. CLS. 100, 101 AND 102).

FIRST USE 4-7-1993; IN COMMERCE 4-7-1993.
YAT SYE, LEE, EXAMINING ATTORNEY

SN 85-294,267. FOUNDERS FINANCIAL, INC., TOWSON, MD. FILED 4-13-2011.



FOR FINANCIAL INVESTMENT BROKERAGE SERVICES; FINANCIAL MANAGEMENT; FINANCIAL PLANNING AND INVESTMENT ADVISORY SERVICES; FINANCIAL SERVICES, NAMELY, INVESTMENT ADVICE, INVESTMENT MANAGEMENT, INVESTMENT CONSULTATION AND INVESTMENT OF FUNDS FOR OTHERS, INCLUDING PRIVATE AND PUBLIC EQUITY AND DEBT INVESTMENT SERVICES (U.S. CLS. 100, 101 AND 102).

FIRST USE 5-31-2002; IN COMMERCE 5-31-2002.
MARILYN IZZI, EXAMINING ATTORNEY

CLASS 36—(Continued).

SN 85-294,289. FOUNDERS FINANCIAL, INC., TOWSON, MD. FILED 4-13-2011.

**SHARED RESOURCES. SHARED
VALUES.**

THE MARK CONSISTS OF STANDARD CHARACTERS WITHOUT CLAIM TO ANY PARTICULAR FONT, STYLE, SIZE, OR COLOR.

FOR FINANCIAL INVESTMENT BROKERAGE SERVICES; FINANCIAL MANAGEMENT; FINANCIAL PLANNING AND INVESTMENT ADVISORY SERVICES; FINANCIAL SERVICES, NAMELY, INVESTMENT ADVICE, INVESTMENT MANAGEMENT, INVESTMENT CONSULTATION AND INVESTMENT OF FUNDS FOR OTHERS, INCLUDING PRIVATE AND PUBLIC EQUITY AND DEBT INVESTMENT SERVICES (U.S. CLS. 100, 101 AND 102).

FIRST USE 5-31-2002; IN COMMERCE 5-31-2002.
MARILYN IZZI, EXAMINING ATTORNEY

SN 85-294,399. BEACON POINTE ADVISORS, LLC, NEWPORT BEACH, CA. FILED 4-13-2011.

BEACON POINTE

THE MARK CONSISTS OF STANDARD CHARACTERS WITHOUT CLAIM TO ANY PARTICULAR FONT, STYLE, SIZE, OR COLOR.

FOR FINANCIAL PLANNING AND INVESTMENT ADVISORY SERVICES (U.S. CLS. 100, 101 AND 102).

FIRST USE 2-1-2002; IN COMMERCE 2-1-2002.
MIDGE BUTLER, EXAMINING ATTORNEY

SN 85-294,581. REZOLVE GROUP, INC., BOSTON, MA. FILED 4-13-2011.

ACCESS FOR ALL

THE MARK CONSISTS OF STANDARD CHARACTERS WITHOUT CLAIM TO ANY PARTICULAR FONT, STYLE, SIZE, OR COLOR.

FOR FINANCIAL COUNSELING SERVICES, NAMELY, ASSISTING LOW INCOME STUDENTS WITH UNDERSTANDING AND PLANNING FOR COLLEGE EXPENSES, ASSISTING LOW INCOME STUDENTS WITH THE PREPARATION OF FEDERAL FINANCIAL AID FORMS AND PROVIDING INFORMATION ON THE COSTS OF HIGHER EDUCATION, SCHOLARSHIPS AND FINANCIAL AID (U.S. CLS. 100, 101 AND 102).

FIRST USE 9-30-2009; IN COMMERCE 9-30-2009.
KAREN BRACEY, EXAMINING ATTORNEY

CLASS 36—(Continued).

SN 85-294,710. SPARKLES OF LIFE, INC, SUGAR LAND, TX. FILED 4-13-2011.

Mother's Heart Brunch

THE MARK CONSISTS OF STANDARD CHARACTERS WITHOUT CLAIM TO ANY PARTICULAR FONT, STYLE, SIZE, OR COLOR.

NO CLAIM IS MADE TO THE EXCLUSIVE RIGHT TO USE "BRUNCH", APART FROM THE MARK AS SHOWN. FOR CHARITABLE FUNDRAISING TO SUPPORT SPARKLES OF LIFE AND ITS PROGRAMS (U.S. CLS. 100, 101 AND 102).

FIRST USE 7-0-2010; IN COMMERCE 7-0-2010.
GRETTA YAO, EXAMINING ATTORNEY

SN 85-294,973. CASTLEBRIDGE CAPITAL, LLC, AUSTIN, TX. FILED 4-14-2011.

Castlebridge Capital

THE MARK CONSISTS OF STANDARD CHARACTERS WITHOUT CLAIM TO ANY PARTICULAR FONT, STYLE, SIZE, OR COLOR.

NO CLAIM IS MADE TO THE EXCLUSIVE RIGHT TO USE "CAPITAL", APART FROM THE MARK AS SHOWN.

FOR REAL ESTATE FINANCING (U.S. CLS. 100, 101 AND 102).

FIRST USE 11-26-2008; IN COMMERCE 11-26-2008.
REBECCA EISINGER, EXAMINING ATTORNEY

SN 85-294,987. TIB THE INDEPENDENT BANKERSBANK, IRVING, TX. FILED 4-14-2011.

POINT. CLICK. CLEAR.

THE MARK CONSISTS OF STANDARD CHARACTERS WITHOUT CLAIM TO ANY PARTICULAR FONT, STYLE, SIZE, OR COLOR.

FOR FINANCIAL SERVICES, NAMELY PROVIDING CASH LETTER AND CHECK PROCESSING SERVICES (U.S. CLS. 100, 101 AND 102).

ANDREA HACK, EXAMINING ATTORNEY

CLASS 36—(Continued).

SN 85-295,019. HOMETOWN OF HOMESTEAD BANKING COMPANY, HOMESTEAD, FL. FILED 4-14-2011.



OWNER OF U.S. REG. NO. 2,667,967.
NO CLAIM IS MADE TO THE EXCLUSIVE RIGHT TO USE "THE IMAGE OF A RECYCLING SYMBOL AND DESIGNATION 1ST"., APART FROM THE MARK AS SHOWN.

THE MARK CONSISTS OF A DOG'S FACE, COLLAR WITH "1ST" ATTACHED AS THE DOG TAG, AND PAWS WITHIN A RECYCLE BACKGROUND DESIGN CONSISTING OF THREE BENT ARROWS COMPRISING A TRIANGLE DESIGN.

FOR BANKING SERVICES (U.S. CLS. 100, 101 AND 102).

FIRST USE 12-21-2010; IN COMMERCE 12-21-2010.
DAVID C. REIHNER, EXAMINING ATTORNEY

SN 85-296,793. AIR AMBULANCE CARD, LLC, BIRMINGHAM, AL. FILED 4-15-2011.



OWNER OF U.S. REG. NOS. 3,144,234 AND 3,190,963.
THE MARK CONSISTS OF AN AIRPLANE TAILFIN CONTAINING A STYLIZED EMERGENCY MEDICAL CROSS.

FOR ADMINISTRATION OF A PRE-PAID HEALTH PLAN PROVIDING PRE-PAID AIR MEDICAL TRANSPORTATION (U.S. CLS. 100, 101 AND 102).

FIRST USE 6-30-2010; IN COMMERCE 6-30-2010.
JULIE WATSON, EXAMINING ATTORNEY

CLASS 36—(Continued).

SN 85-296,896. PINE RIVER CAPITAL MANAGEMENT L.P., MINNETONKA, MN. FILED 4-15-2011.

PINE RIVER

THE MARK CONSISTS OF STANDARD CHARACTERS WITHOUT CLAIM TO ANY PARTICULAR FONT, STYLE, SIZE, OR COLOR.

FOR FINANCIAL ASSET MANAGEMENT (U.S. CLS. 100, 101 AND 102).

FIRST USE 6-30-2002; IN COMMERCE 6-30-2002.
ELLEN B. AWRICH, EXAMINING ATTORNEY

SN 85-304,191. GAP (APPAREL), LLC, SAN FRANCISCO, CA. FILED 4-25-2011.

BE WHAT'S POSSIBLE

THE MARK CONSISTS OF STANDARD CHARACTERS WITHOUT CLAIM TO ANY PARTICULAR FONT, STYLE, SIZE, OR COLOR.

FOR CHARITABLE FOUNDATION SERVICES, NAMELY, PROVIDING FINANCIAL ASSISTANCE FOR PROGRAMS AND SERVICES OF OTHERS (U.S. CLS. 100, 101 AND 102).

ANNE MADDEN, EXAMINING ATTORNEY

SN 85-309,484. QUICKEN LOANS INC., DETROIT, MI. FILED 5-2-2011.

YOURGAGE

THE MARK CONSISTS OF STANDARD CHARACTERS WITHOUT CLAIM TO ANY PARTICULAR FONT, STYLE, SIZE, OR COLOR.

FOR MORTGAGE LENDING, ORIGATION AND SERVICING (U.S. CLS. 100, 101 AND 102).

KATHERINE CHANG, EXAMINING ATTORNEY

CLASS 36—(Continued).

SN 85-312,328. AMALGAMATED BANK, NEW YORK, NY. FILED 5-4-2011.

AMALGAMATEDONLINE TREASURY
MANAGER

THE MARK CONSISTS OF STANDARD CHARACTERS WITHOUT CLAIM TO ANY PARTICULAR FONT, STYLE, SIZE, OR COLOR.

OWNER OF U.S. REG. NOS. 2,844,038, 3,969,735 AND OTHERS.

NO CLAIM IS MADE TO THE EXCLUSIVE RIGHT TO USE "TREASURY MANAGER", APART FROM THE MARK AS SHOWN.

FOR CASH MANAGEMENT SERVICES RELATING TO DEPOSIT ACCOUNTS MAINTAINED BY A COMMERCIAL BANK, WHICH FACILITATE PROVIDING INFORMATION REGARDING ACCOUNT BALANCES AND TRANSACTIONS, COMMUNICATING WITH ACCOUNT HOLDERS, AND EFFECTING ELECTRONIC TRANSACTIONS TO AND FROM SUCH ACCOUNTS (U.S. CLS. 100, 101 AND 102).

FIRST USE 10-1-2010; IN COMMERCE 10-1-2010.
MARK SHINER, EXAMINING ATTORNEY

SN 85-312,662. OTTER PRODUCTS, LLC, FORT COLLINS, CO. FILED 5-4-2011.

PINK IS STRENGTH!

THE MARK CONSISTS OF STANDARD CHARACTERS WITHOUT CLAIM TO ANY PARTICULAR FONT, STYLE, SIZE, OR COLOR.

FOR CHARITABLE FUNDRAISING (U.S. CLS. 100, 101 AND 102).

FIRST USE 5-8-2008; IN COMMERCE 5-8-2008.
KATHERINE CONNOLLY, EXAMINING ATTORNEY

SN 85-313,235. NORTHEAST BANCORP, BOSTON, MA. FILED 5-5-2011.

BANKWORTHY

THE MARK CONSISTS OF STANDARD CHARACTERS WITHOUT CLAIM TO ANY PARTICULAR FONT, STYLE, SIZE, OR COLOR.

FOR BANKING SERVICES (U.S. CLS. 100, 101 AND 102).

KAREN BRACEY, EXAMINING ATTORNEY

CLASS 36—(Continued).

SN 85-313,453. UNITED STATES DEPARTMENT OF THE TREASURY, WASHINGTON, DC. FILED 5-5-2011.

CheckMyNPV

THE MARK CONSISTS OF STANDARD CHARACTERS WITHOUT CLAIM TO ANY PARTICULAR FONT, STYLE, SIZE, OR COLOR.

FOR MORTGAGE SERVICES, NAMELY, AN ONLINE CALCULATOR FOR THE CALCULATION OF THE NET PRESENT VALUE (NPV) OF A MORTGAGE (U.S. CLS. 100, 101 AND 102).

ARETHA SOMERVILLE, EXAMINING ATTORNEY

SN 85-314,181. AKITA, INC., WILMINGTON, DE. FILED 5-6-2011.

EAGLE CHEMPROTECT

THE MARK CONSISTS OF STANDARD CHARACTERS WITHOUT CLAIM TO ANY PARTICULAR FONT, STYLE, SIZE, OR COLOR.

OWNER OF U.S. REG. NO. 2,069,597.

FOR INSURANCE UNDERWRITING IN THE FIELD OF POLLUTION LEGAL LIABILITY (U.S. CLS. 100, 101 AND 102).

SUSAN RICHARDS, EXAMINING ATTORNEY

SN 85-320,045. FANPLAY, INC., LUBBOCK, TX. FILED 5-13-2011.

FANPLAY4CHARITY

THE MARK CONSISTS OF STANDARD CHARACTERS WITHOUT CLAIM TO ANY PARTICULAR FONT, STYLE, SIZE, OR COLOR.

FOR ELEEMOSYNARY SERVICES IN THE FIELD OF MONETARY DONATIONS (U.S. CLS. 100, 101 AND 102).

LESLIE RICHARDS, EXAMINING ATTORNEY

CLASS 36—(Continued).

SN 85-320,690. AMERICAN INTERNATIONAL GROUP, INC., NEW YORK, NY. FILED 5-13-2011.

**MONEY WHEN IT REALLY
MATTERS...A SAFEGUARD
AGAINST LIFE'S 'WHAT IFS'**

THE MARK CONSISTS OF STANDARD CHARACTERS WITHOUT CLAIM TO ANY PARTICULAR FONT, STYLE, SIZE, OR COLOR.

FOR ANNUITY UNDERWRITING; INSURANCE UNDERWRITING IN THE FIELD OF LIFE AND ACCIDENT AND HEALTH INSURANCE; ISSUANCE AND ADMINISTRATION OF ANNUITIES (U.S. CLS. 100, 101 AND 102).

NAAKWAMA ANKRAH, EXAMINING ATTORNEY

SN 85-321,993. INSPHERE INSURANCE SOLUTIONS, INC., NORTH RICHLAND HILLS, TX. FILED 5-16-2011.

INSPHERE INVEST

THE MARK CONSISTS OF STANDARD CHARACTERS WITHOUT CLAIM TO ANY PARTICULAR FONT, STYLE, SIZE, OR COLOR.

OWNER OF U.S. REG. NOS. 3,826,236, 3,826,283 AND 3,926,658.

NO CLAIM IS MADE TO THE EXCLUSIVE RIGHT TO USE "INVEST", APART FROM THE MARK AS SHOWN.

FOR INVESTMENT OF FUNDS FOR INDEPENDENT INSURANCE AGENTS IN STOCK PURCHASE PLANS (U.S. CLS. 100, 101 AND 102).

FIRST USE 1-1-2010; IN COMMERCE 1-1-2010.
LIEF MARTIN, EXAMINING ATTORNEY

SN 85-322,000. INSPHERE INSURANCE SOLUTIONS, INC., NORTH RICHLAND HILLS, TX. FILED 5-16-2011.

INSPHERE INSITE

THE MARK CONSISTS OF STANDARD CHARACTERS WITHOUT CLAIM TO ANY PARTICULAR FONT, STYLE, SIZE, OR COLOR.

OWNER OF U.S. REG. NOS. 3,826,236, 3,917,954 AND OTHERS.

FOR PROVIDING ON-LINE INFORMATION TO INSURANCE AGENTS REGARDING INSURANCE POLICIES, ADMINISTRATION, AND UNDERWRITING (U.S. CLS. 100, 101 AND 102).

FIRST USE 1-1-2010; IN COMMERCE 1-1-2010.
LIEF MARTIN, EXAMINING ATTORNEY

CLASS 36—(Continued).

SN 85-325,682. WOUNDED WARRIOR PROJECT, INC., JACKSONVILLE, FL. FILED 5-20-2011.

**PUT THE VETERAN BACK IN
VETERANS DAY**

THE MARK CONSISTS OF STANDARD CHARACTERS WITHOUT CLAIM TO ANY PARTICULAR FONT, STYLE, SIZE, OR COLOR.

FOR CHARITABLE FUNDRAISING SERVICES (U.S. CLS. 100, 101 AND 102).

DAVID C. REIHNER, EXAMINING ATTORNEY

SN 85-328,217. HARTFORD LIFE INSURANCE COMPANY, HARTFORD, CT. FILED 5-24-2011.

INCOME FOR LIFE'S OUTCOMES

THE MARK CONSISTS OF STANDARD CHARACTERS WITHOUT CLAIM TO ANY PARTICULAR FONT, STYLE, SIZE, OR COLOR.

FOR INSURANCE SERVICES, NAMELY, INSURANCE UNDERWRITING, ISSUING, ADMINISTRATION, AGENCY AND BROKERAGE SERVICES IN THE FIELD OF INDIVIDUAL LIFE INSURANCE (U.S. CLS. 100, 101 AND 102).

FIRST USE 3-31-2011; IN COMMERCE 3-31-2011.

TIMOTHY FINNEGAN, EXAMINING ATTORNEY

SN 85-328,803. STUMPE FOUNDATION, INC., ATLANTA, GA. FILED 5-24-2011.



THE MARK CONSISTS OF A CIRCLE WITH THE WORDS "CHILDREN OF CONSERVATION" IN THE UPPER LEFT

CLASS 36—(Continued).

CORNER OF THE CIRCLE HAVING THE "C" OF "CHILDREN" AND THE "CON" OF "CONSERVATION" APPEARING OUTSIDE THE CIRCLE AND THE SILHOUETTES OF A FEMALE CHILD ON THE RIGHT HOLDING THE HAND OF A CHIMPANZEE AND THE TWO FIGURES WALKING TOGETHER WITH THE CHIMPANZEE APPEARING UNDERNEATH THE WORDING AND THE RIGHT FOOT OF THE FEMALE CHILD AND THE RIGHT LOWER ARM/HAND AND RIGHT LEG OF THE CHIMPANZEE APPEARING OUTSIDE THE CIRCLE.

FOR CHARITABLE FUNDRAISING (U.S. CLS. 100, 101 AND 102).

FIRST USE 3-30-2011; IN COMMERCE 3-30-2011.
EMILY CARLSEN, EXAMINING ATTORNEY

CLASS 36—(Continued).

SN 85-362,016. VERIT ADVISORS LLC, CHICAGO, IL. FILED 7-1-2011.

VERIT

SN 85-329,100. DART INDUSTRIES INC., ORLANDO, FL. FILED 5-24-2011.

THE MARK CONSISTS OF STANDARD CHARACTERS WITHOUT CLAIM TO ANY PARTICULAR FONT, STYLE, SIZE, OR COLOR.

FOR INVESTMENT BANKING; MERGERS AND ACQUISITIONS ADVISORY SERVICES (U.S. CLS. 100, 101 AND 102).

FIRST USE 11-3-2010; IN COMMERCE 11-3-2010.
GRETTA YAO, EXAMINING ATTORNEY

CONFIDE + CONQUER

THE MARK CONSISTS OF STANDARD CHARACTERS WITHOUT CLAIM TO ANY PARTICULAR FONT, STYLE, SIZE, OR COLOR.

FOR CHARITABLE FUNDRAISING SERVICES (U.S. CLS. 100, 101 AND 102).

JULIE GUTTADAURO, EXAMINING ATTORNEY

SN 85-362,062. VERIT ADVISORS LLC, CHICAGO, IL. FILED 7-1-2011.



SN 85-345,789. AKITA, INC., WILMINGTON, DE. FILED 6-14-2011.

MOVING A&HEAD

THE MARK CONSISTS OF STANDARD CHARACTERS WITHOUT CLAIM TO ANY PARTICULAR FONT, STYLE, SIZE, OR COLOR.

FOR INSURANCE UNDERWRITING IN THE FIELD OF ACCIDENT AND HEALTH (U.S. CLS. 100, 101 AND 102).

SUSAN RICHARDS, EXAMINING ATTORNEY

THE COLOR(S) GREEN IS/ARE CLAIMED AS A FEATURE OF THE MARK.

THE MARK CONSISTS OF THE LITERAL ELEMENT OF THE MARK RENDERED IN TWO SHADES OF GREEN LETTERING; THE INITIAL "V" APPEARS IN A SMOOTH, SANS-SERIF FONT, THE REMAINDER OF THE LETTERS OF THE LITERAL ELEMENT ARE IN SERIF FONT; A DARK GREEN CIRCULAR DISK APPEARS SUSPENDED ABOVE THE INITIAL "V", WHICH IS RENDERED IN LIGHTER GREEN, THE LETTERS "ERIT" APPEAR IN DARKER GREEN, WITH THE DOT OF THE "I" RENDERED IN LIGHTER GREEN.

FOR INVESTMENT BANKING; MERGERS AND ACQUISITIONS ADVISORY SERVICES (U.S. CLS. 100, 101 AND 102).

FIRST USE 11-3-2010; IN COMMERCE 11-3-2010.
GRETTA YAO, EXAMINING ATTORNEY

CLASS 36—(Continued).

SN 85-362,141. VERIT ADVISORS LLC, CHICAGO, IL. FILED 7-1-2011.



THE COLOR(S) GREEN IS/ARE CLAIMED AS A FEATURE OF THE MARK.

THE MARK CONSISTS OF THE LETTER "V" APPEARING IN A LIGHT GREEN AND IN A SMOOTH, SANS-SERIF FONT, A DARK GREEN CIRCULAR DISK APPEARS SUSPENDED ABOVE THE LETTER "V".

FOR INVESTMENT BANKING; MERGERS AND ACQUISITIONS ADVISORY SERVICES (U.S. CLS. 100, 101 AND 102).

FIRST USE 11-3-2010; IN COMMERCE 11-3-2010.
GRETTA YAO, EXAMINING ATTORNEY

CLASS 37—(Continued).

SN 76-707,219. PROTO HOMES, LLC, LOS ANGELES, CA. FILED 4-12-2011.

PROTO HOMES

THE MARK CONSISTS OF STANDARD CHARACTERS WITHOUT CLAIM TO ANY PARTICULAR FONT, STYLE, SIZE, OR COLOR.

NO CLAIM IS MADE TO THE EXCLUSIVE RIGHT TO USE "HOMES", APART FROM THE MARK AS SHOWN. FOR RESIDENTIAL AND COMMERCIAL BUILDING CONSTRUCTION (U.S. CLS. 100, 103 AND 106).

FIRST USE 1-0-2010; IN COMMERCE 1-0-2010.
KAREN BRACEY, EXAMINING ATTORNEY

SN 77-231,974. NERDS ON CALL, INC., REDDING, CA. FILED 7-17-2007.

CLASS 37—CONSTRUCTION AND REPAIR

SN 76-707,148. EXTERMICARE PEST SOLUTIONS, LLC, CAPE CORAL, FL. FILED 4-7-2011.

EXTERMICARE

THE MARK CONSISTS OF STANDARD CHARACTERS WITHOUT CLAIM TO ANY PARTICULAR FONT, STYLE, SIZE, OR COLOR.

FOR PEST CONTROL SERVICES (U.S. CLS. 100, 103 AND 106).

FIRST USE 11-1-2010; IN COMMERCE 11-1-2010.
MORGAN WYNNE, EXAMINING ATTORNEY

NERDS ON CALL

THE MARK CONSISTS OF STANDARD CHARACTERS WITHOUT CLAIM TO ANY PARTICULAR FONT, STYLE, SIZE, OR COLOR.

SUBJECT TO CONCURRENT USE PROCEEDING WITH NERDS ON CALL, INC. (INDIANA CORPORATION), NERDS ON CALL, INC. (CALIFORNIA CORPORATION) CLAIMS THE EXCLUSIVE RIGHT TO USE THE MARK IN THE AREA COMPRISING THE ENTIRE UNITED STATES EXCEPT FOR THE STATE OF INDIANA.

NO CLAIM IS MADE TO THE EXCLUSIVE RIGHT TO USE "ON CALL", APART FROM THE MARK AS SHOWN.

FOR INSTALLATION, MAINTENANCE AND REPAIR OF COMPUTERS FOR HOMES AND BUSINESSES (U.S. CLS. 100, 103 AND 106).

FIRST USE 3-0-2004; IN COMMERCE 3-0-2004.
KIMBERLY PERRY, EXAMINING ATTORNEY

CLASS 37—(Continued).

SN 77-353,947. BUBBLES ENTERPRISES LTD., HOUSTON, TX. FILED 12-17-2007.



OWNER OF U.S. REG. NOS. 1,930,563, 1,949,995 AND 1,949,996.

NO CLAIM IS MADE TO THE EXCLUSIVE RIGHT TO USE "HAND CAR WASH", APART FROM THE MARK AS SHOWN.

THE MARK CONSISTS OF A ROUND BUBBLE AS THE BACKGROUND WITH "BUBBLES" WRITTEN OVER IT HORIZONTALLY AND "HAND CAR WASH" WRITTEN BELOW "BUBBLES".

FOR AUTOMOBILE WASHING AND CLEANING SERVICES, NAMELY, HAND WASHING AND CLEANING SERVICES PERFORMED ON PREMISES (U.S. CLS. 100, 103 AND 106).

FIRST USE 11-30-2006; IN COMMERCE 11-30-2006.
JOHN KELLY, EXAMINING ATTORNEY

Kröme

THE MARK CONSISTS OF STANDARD CHARACTERS WITHOUT CLAIM TO ANY PARTICULAR FONT, STYLE, SIZE, OR COLOR.

FOR INSTALLATION OF CUSTOM GARAGE STORAGE SOLUTIONS AND ACCESSORIES (U.S. CLS. 100, 103 AND 106).

KHANH LE, EXAMINING ATTORNEY

CLASS 37—(Continued).

SN 77-912,242. DECO WINDSHIELD REPAIR INC., CALGARY, CANADA, FILED 1-14-2010.



NO CLAIM IS MADE TO THE EXCLUSIVE RIGHT TO USE "WINDSHIELD REPAIR INC.", APART FROM THE MARK AS SHOWN.

THE COLOR(S) ORANGE, BLACK AND WHITE IS/ARE CLAIMED AS A FEATURE OF THE MARK.

THE MARK CONSISTS OF THE WORD "DECO" IN BOLDED STYLIZED FORM IN THE COLOR ORANGE, THE WORDING "WINDSHIELD REPAIR INC." IN THE COLOR WHITE, A STAR WITH FOUR POINTS IN THE COLOR BLACK ON AN ORANGE BACKGROUND; ALL WITHIN A SQUARE; ALL AGAINST A BLACK RECTANGULAR DESIGN.

FOR AUTOMOTIVE SERVICES, NAMELY, WINDSHIELD REPAIR, DENT REPAIR, AUTOMOBILE DETAILING AND CLEANING (U.S. CLS. 100, 103 AND 106).
MARC LEIPZIG, EXAMINING ATTORNEY

SN 77-958,671. KENCO ELECTRIC, INC., WINSTON-SALEM, NC. FILED 3-15-2010.



NO CLAIM IS MADE TO THE EXCLUSIVE RIGHT TO USE "ELECTRIC, INC SINCE 1988", APART FROM THE MARK AS SHOWN.

THE COLOR(S) BLUE, WHITE, BLACK, GREY, BROWN AND YELLOW IS/ARE CLAIMED AS A FEATURE OF THE MARK.

THE MARK CONSISTS OF THE WORDING "KENCO ELECTRIC, INC SINCE 1988" IN BLUE LETTERING. BETWEEN THE WORDS "KENCO" AND "ELECTRIC, INC" IS A STYLIZED MALE CHARACTER WITH WHITE HANDS AND FACE, BLACK FACIAL FEATURES, A GREY SHIRT, BLUE OVERALLS, BROWN SHOES, BLACK HAIR, A BLUE HAT WITH A YELLOW AND BLACK LIGHTNING BOLT AND A YELLOW AND BLACK PENCIL BEHIND HIS EAR. THE CHARACTER IS HOLDING A GREY AND BLACK TOOL BOX AND IS SLIDING DOWN A YELLOW AND BLACK LIGHTNING BOLT. THE ENTIRE DESIGN IS OUTLINED IN BLACK. THE WHITE BACKGROUND IS NOT A PART OF THE MARK.

FOR ELECTRICAL CONTRACTING; ELECTRICAL CONTRACTOR SERVICES; ELECTRICAL REPAIRS AND INSTALLATION OF LIGHTING FIXTURES; ELECTRICAL REPAIRS, MAINTENANCE, AND INSTALLATION OF ELECTRICAL WIRING, OUTLETS, LIGHT FIXTURES, AND ELECTRICAL PANELS; INSTALLATION OF LIGHTING FIXTURES; INSTALLATION, MAINTENANCE AND REPAIR OF ELECTRICAL SYSTEM; REPAIR OR MAINTENANCE OF ELECTRIC LIGHTING APPARATUS (U.S. CLS. 100, 103 AND 106).

RENEE SERVANCE, EXAMINING ATTORNEY

CLASS 37—(Continued).

SN 85-041,953. INDUSTRIAL HYGIENE, ENVIRONMENTAL AND SAFETY SERVICES, LOLO, MT. FILED 5-18-2010.

"They Cook, We Clean"

THE MARK CONSISTS OF STANDARD CHARACTERS WITHOUT CLAIM TO ANY PARTICULAR FONT, STYLE, SIZE, OR COLOR.

FOR CLEANING OF ILLEGAL CLANDESTINE DRUG LAB SITES, INCLUDING METHAMPHETAMINE LABS (U.S. CLS. 100, 103 AND 106).

FIRST USE 7-1-2009; IN COMMERCE 8-15-2009.
STEVEN PEREZ, EXAMINING ATTORNEY

SN 85-063,379. THE SPRING WORKS LLC, GRAND JUNCTION, CO. FILED 6-15-2010.



NO CLAIM IS MADE TO THE EXCLUSIVE RIGHT TO USE "THE SPRING WORKS", APART FROM THE MARK AS SHOWN.

THE COLOR(S) MAROON, BLACK, GRAY AND WHITE IS/ARE CLAIMED AS A FEATURE OF THE MARK.

THE MARK CONSISTS OF THE WORDING "THE" IN BLACK, "SPRING WORKS" IN MAROON AND OUTLINED IN BLACK, WITH A BLACK SPRING REPLACING THE LETTER "I", AND A DESIGN OF A WHITE LEAF SPRING OUTLINED IN BLACK, ALL WITHIN A GRAY AND WHITE RECTANGLE.

FOR PERFORMING MAINTENANCE, MODIFICATIONS, AND GENERAL PURPOSE REPAIR ON LAND VEHICLES, RECREATIONAL VEHICLES, LIVESTOCK, UTILITY AND BOAT TRAILERS; INSTALLATION, REPAIR AND MAINTENANCE OF VEHICLE SUSPENSIONS, INCLUDING COIL SPRINGS LEAF SPRINGS AND OVERLOAD SUSPENSIONS; INSTALLATION OF VEHICLE HITCHES INCLUDING RECEIVER, GOOSE-NECK AND 5TH WHEEL HITCHES; INSTALLATION OF VEHICLE AND TRAILER ACCESSORIES (U.S. CLS. 100, 103 AND 106).

FIRST USE 3-1-1993; IN COMMERCE 3-1-1993.
APRIL ROACH, EXAMINING ATTORNEY

CLASS 37—(Continued).

SN 85-123,162. TECHTERIORS, LLC, MEQUON, WI. FILED 9-3-2010.

TECHTERIORS
Intelligent Environments

OWNER OF U.S. REG. NO. 2,686,034.

NO CLAIM IS MADE TO THE EXCLUSIVE RIGHT TO USE "INTELLIGENT ENVIRONMENTS", APART FROM THE MARK AS SHOWN.

THE COLOR(S) RED AND GRAY IS/ARE CLAIMED AS A FEATURE OF THE MARK.

THE MARK CONSISTS OF "TECHTERIORS INTELLIGENT ENVIRONMENTS" WITH THE "TECH" PORTION OF THE TERM "TECHTERIORS" IN RED AND THE REMAINING WORDING IN GRAY.

FOR INSTALLATION OF HOME AUTOMATION SYSTEMS (U.S. CLS. 100, 103 AND 106).

FIRST USE 4-4-2005; IN COMMERCE 4-4-2005.

BILL DAWE, EXAMINING ATTORNEY

SN 85-125,960. ARAMENDIA HOLDINGS, LLC, SAN ANTONIO, TX. FILED 9-9-2010.

ARAMENDIA

THE MARK CONSISTS OF STANDARD CHARACTERS WITHOUT CLAIM TO ANY PARTICULAR FONT, STYLE, SIZE, OR COLOR.

FOR REPAIR, MAINTENANCE, REPLACEMENT, AND INSTALLATION SERVICES IN THE FIELD OF PLUMBING, HEATING, VENTILATION, AND AIR CONDITIONING; SEWER AND DRAIN CLEANING (U.S. CLS. 100, 103 AND 106).

FIRST USE 3-0-1988; IN COMMERCE 3-0-1988.

KEVON CHISOLM, EXAMINING ATTORNEY

SN 85-126,535. MCKNIGHT,DANIEL, WINCHESTER, IN. FILED 9-10-2010.

FUTURE SIGNS SALES & GRAPHICS LLC.

THE MARK CONSISTS OF STANDARD CHARACTERS WITHOUT CLAIM TO ANY PARTICULAR FONT, STYLE, SIZE, OR COLOR.

NO CLAIM IS MADE TO THE EXCLUSIVE RIGHT TO USE "SIGNS SALES & GRAPHICS LLC", APART FROM THE MARK AS SHOWN.

FOR INSTALLATION, MAINTENANCE, AND REPAIR OF COMMERCIAL SIGNS AND SIGNAGE (U.S. CLS. 100, 103 AND 106).

FIRST USE 6-1-2010; IN COMMERCE 6-1-2010.

BRIAN NEVILLE, EXAMINING ATTORNEY

CLASS 37—(Continued).

SN 85-137,711. WEB INDUSTRIES, INC., MARLBOROUGH, MA. FILED 9-24-2010.

 The logo for STEP-PAC features the words "STEP-PAC" in a bold, blocky, sans-serif font. The letters are white with a thick black outline. The text is centered between two horizontal black bars, one above and one below.

OWNER OF U.S. REG. NOS. 1,335,511 AND 2,753,884.
FOR PACKAGING SERVICES, NAMELY, WINDING
OF FLEXIBLE TAPE INTO PRE-WOUND PACKAGES
FOR OTHERS (U.S. CLS. 100, 103 AND 106).
FIRST USE 3-13-1987; IN COMMERCE 3-13-1987.
KRISTINA MORRIS, EXAMINING ATTORNEY

CLASS 37—(Continued).

SN 85-245,023. PROFESSIONAL SALES RV LP, COLLEYVILLE, TX. FILED 2-17-2011.



SN 85-168,477. BOLLA OIL CORP., GARDEN CITY, NY.
FILED 11-3-2010.



THE MARK CONSISTS OF THE PROFILE OF A ROARING LION'S HEAD, WITHIN A CIRCLE, WITH A THIN BAND AROUND THE OUTER EDGE OF THE CIRCLE, WITHIN A SQUARE. APPEARING BELOW THE LION'S HEAD, CIRCLE, AND SQUARE IS THE STYLIZED WORD "BOLLA", ALL WITHIN A LARGE RECTANGLE.
FOR AUTOMOBILE SERVICE STATION SERVICES (U.S. CLS. 100, 103 AND 106).
JESSICA FATHY, EXAMINING ATTORNEY

NO CLAIM IS MADE TO THE EXCLUSIVE RIGHT TO USE TOUCH-UP, APART FROM THE MARK AS SHOWN.

THE MARK CONSISTS OF A PAINT GUN SHOOTING PAINT IN A FAN PATTERN AND THE WORDING "TOUCH-UP MASTERS".

FOR MOBILE AUTOMOBILE BODY REPAIR AND FINISHING FOR OTHERS (U.S. CLS. 100, 103 AND 106).
FIRST USE 1-3-2005; IN COMMERCE 1-3-2005.
DAVID TAYLOR, EXAMINING ATTORNEY

SN 85-253,540. COMAU, INC., SOUTHFIELD, MI. FILED 2-28-2011.

 The logo for GREEN-FIT consists of the words "GREEN-FIT" in a bold, black, sans-serif font. The letters are widely spaced and have a slightly irregular, hand-drawn appearance.

SN 85-219,770. CVZ DEZIGNS, INC., JOPPA, MD. FILED 1-18-2011.

 The logo for CVZ DEZIGNS consists of the words "CVZ DEZIGNS" in a bold, black, sans-serif font. The letters are widely spaced and have a slightly irregular, hand-drawn appearance.

THE MARK CONSISTS OF STANDARD CHARACTERS WITHOUT CLAIM TO ANY PARTICULAR FONT, STYLE, SIZE, OR COLOR.

NO CLAIM IS MADE TO THE EXCLUSIVE RIGHT TO USE "DESIGNS", APART FROM THE MARK AS SHOWN.

FOR CONSULTATION SERVICES IN THE FIELD OF GREEN BUILDING CONSTRUCTION AND BUILDING FACILITIES OPERATIONS (U.S. CLS. 100, 103 AND 106).
ANNE FARRELL, EXAMINING ATTORNEY

THE MARK CONSISTS OF STANDARD CHARACTERS WITHOUT CLAIM TO ANY PARTICULAR FONT, STYLE, SIZE, OR COLOR.

FOR IMPLEMENTATION OF TOOLS AND MODIFICATIONS FOR IMPROVING ENERGY EFFICIENCY, NAMELY, INSTALLATION OF SENSORS AND COMPUTER SYSTEMS TO MONITOR AND MEASURE ENERGY EFFICIENCY, MODIFICATION OF COMMERCIAL, INDUSTRIAL AND INSTITUTIONAL ELECTRICAL APPARATUS TO IMPROVE ENERGY EFFICIENCY (U.S. CLS. 100, 103 AND 106).

ANDREW LEASER, EXAMINING ATTORNEY

CLASS 37—(Continued).

SN 85-260,951. RAM SERVICES, INC., WOODSTOCK, GA. FILED 3-8-2011.



NO CLAIM IS MADE TO THE EXCLUSIVE RIGHT TO USE "SERVICES, INC." OR "ROLL & COIL STRAIGHTENING SERVICE", APART FROM THE MARK AS SHOWN.

THE MARK CONSISTS OF THE STYLIZED WORD "RAM" WHERE AN ANIMAL HEAD AND SEVERAL CONCENTRIC CIRCLES FORM THE TOP PORTION OF THE "R" WITH THE PHRASE "ON THE ROLL" PRINTED VERTICALLY ON THE RIGHT SIDE OF THE "M" AND THE PHRASE "SERVICES, INC." APPEARING BELOW THE WORD "RAM" AND THE PHRASE "ROLL & COIL STRAIGHTENING SERVICE" APPEARING BELOW "SERVICES, INC."

FOR ROLL AND COIL STRAIGHTENING SERVICES IN THE FIELDS OF PAPER ROLLS, METAL ROLLS, FOIL ROLLS, AND THE LIKE (U.S. CLS. 100, 103 AND 106).

FIRST USE 12-31-1996; IN COMMERCE 12-31-1996.
TINA L. SNAPP, EXAMINING ATTORNEY

SN 85-263,639. AFTERMATH RESTORATION INC., ORANGE, TX. FILED 3-10-2011.

Aftermath Restoration

THE MARK CONSISTS OF STANDARD CHARACTERS WITHOUT CLAIM TO ANY PARTICULAR FONT, STYLE, SIZE, OR COLOR.

NO CLAIM IS MADE TO THE EXCLUSIVE RIGHT TO USE "RESTORATION", APART FROM THE MARK AS SHOWN.

FOR RENOVATION AND RESTORATION OF BUILDINGS (U.S. CLS. 100, 103 AND 106).

FIRST USE 1-1-2002; IN COMMERCE 4-1-2003.
DAVID ELTON, EXAMINING ATTORNEY

SN 85-273,783. CROSS COUNTRY HOME SERVICES, INC., FT. LAUDERDALE, FL. FILED 3-22-2011.

TAG TEAM

THE MARK CONSISTS OF STANDARD CHARACTERS WITHOUT CLAIM TO ANY PARTICULAR FONT, STYLE, SIZE, OR COLOR.

FOR PROVIDING REMOTE AND ON SITE COMPUTER AND HOME ELECTRONICS INSTALLATION, MAINTENANCE AND REPAIR (U.S. CLS. 100, 103 AND 106).

JESSICA A. POWERS, EXAMINING ATTORNEY

CLASS 37—(Continued).

SN 85-275,305. ANDRZEJ GIENIEC, CHICAGO, IL. FILED 3-24-2011.



NO CLAIM IS MADE TO THE EXCLUSIVE RIGHT TO USE "POWER", APART FROM THE MARK AS SHOWN.

THE MARK CONSISTS OF THE WORDS "POWER TOWER" TO THE RIGHT OF THE IMAGE OF A RECTANGLE HAVING EXTENDED SIDES ON A BACKGROUND RECTANGLE WITH CURVED SIDES.

FOR COMPUTER AND TELEPHONE BATTERY CHARGING SERVICES; COMPUTER AND TELEPHONE BATTERY REGENERATION SERVICES; COMPUTER AND TELEPHONE BATTERY RECHARGE SERVICES; INSTALLATION AND MAINTENANCE OF CELL PHONE AND COMPUTER BATTERIES; INSTALLATION, MAINTENANCE AND REPAIR OF CELL PHONE RELATED HARDWARE; INSTALLATION, MAINTENANCE AND REPAIR OF COMPUTER HARDWARE; INSTALLATION, MAINTENANCE AND REPAIR OF CELL PHONE AND COMPUTER BATTERIES (U.S. CLS. 100, 103 AND 106).

BRENDAN MCCAULEY, EXAMINING ATTORNEY

SN 85-275,542. CF JORDAN CONSTRUCTION, LLC, EL PASO, TX. FILED 3-24-2011.

A Foundation of Excellence

THE MARK CONSISTS OF STANDARD CHARACTERS WITHOUT CLAIM TO ANY PARTICULAR FONT, STYLE, SIZE, OR COLOR.

FOR CONSTRUCTION SERVICES, NAMELY, PLANNING, LAYOUT, AND CONSTRUCTION OF COMMERCIAL AND RESIDENTIAL COMMUNITIES; CONSTRUCTION OF INFRASTRUCTURE, NAMELY, THE PLANNING AND LAYOUT OF PLANNED COMMUNITIES; CONSTRUCTION MANAGEMENT (U.S. CLS. 100, 103 AND 106).

FIRST USE 1-3-2011; IN COMMERCE 1-3-2011.

WILLIAM ROSSMAN, EXAMINING ATTORNEY

CLASS 37—(Continued).

SN 85-275,917. CINTAS HOLDINGS, LLC, MASON, OH. FILED 3-24-2011.

SHRED FIRST

THE MARK CONSISTS OF STANDARD CHARACTERS WITHOUT CLAIM TO ANY PARTICULAR FONT, STYLE, SIZE, OR COLOR.

OWNER OF U.S. REG. NOS. 2,387,889 AND 3,047,946. NO CLAIM IS MADE TO THE EXCLUSIVE RIGHT TO USE "SHRED", APART FROM THE MARK AS SHOWN. FOR SECURE DISPOSAL OF OFFICE AND BUSINESS DOCUMENTS (U.S. CLS. 100, 103 AND 106).
MATTHEW MCDOWELL, EXAMINING ATTORNEY

CLASS 37—(Continued).

SN 85-276,893. STEIN AUTOMOTIVE, INC., LOUISVILLE, KY. FILED 3-25-2011.



THE COLOR(S) BLACK, YELLOW, BROWN, RED, GRAY, AND WHITE IS/ARE CLAIMED AS A FEATURE OF THE MARK.

THE MARK CONSISTS OF A MALE FIGURE FROM THE WAIST UP, HAVING HIS RIGHT ARM CROSSED IN FRONT OF HIS TORSO WITH HIS RIGHT HAND IN A GRAY GLOVE HOLDING A GRAY WRENCH AND WEARING A DARK SHIRT COLORED BLACK WITH SOME GRAY SHADING ON THE SLEEVE, BLACK SUNGLASSES WITH A SMALL GRAY SPOT, AND A BLACK MORTARBOARD WITH YELLOW TASSEL. THE FIGURE HAS RED LIPS AND SKIN IN VARIOUS BROWN TONES WITH A FEW WHITE PORTIONS.

FOR AUTOMOBILE REPAIR AND MAINTENANCE (U.S. CLS. 100, 103 AND 106).
NORA BUCHANAN WILL, EXAMINING ATTORNEY

SN 85-276,568. OXIARMOR, INC., LEE'S SUMMIT, MO. FILED 3-25-2011.

OXIARMOR

THE MARK CONSISTS OF STANDARD CHARACTERS WITHOUT CLAIM TO ANY PARTICULAR FONT, STYLE, SIZE, OR COLOR.

FOR APPLICATION OF ANTIMICROBIAL COATINGS TO SURFACES IN COMMERCIAL AND RESIDENTIAL SETTINGS (U.S. CLS. 100, 103 AND 106).
FIRST USE 11-4-2010; IN COMMERCE 11-4-2010.
BRIAN CALLAGHAN, EXAMINING ATTORNEY

SN 85-277,312. CLEAR VENT, NEW YORK, NY. FILED 3-25-2011.

Clear Vent

THE MARK CONSISTS OF STANDARD CHARACTERS WITHOUT CLAIM TO ANY PARTICULAR FONT, STYLE, SIZE, OR COLOR.

NO CLAIM IS MADE TO THE EXCLUSIVE RIGHT TO USE "VENT", APART FROM THE MARK AS SHOWN. FOR INSTALLATION OF VENTS; REPAIR OF HOUSEHOLD APPLIANCES AND OF RESIDENTIAL HEATING, PLUMBING, AIR CONDITIONING, AND ELECTRICAL SYSTEMS (U.S. CLS. 100, 103 AND 106).
TAMARA FRAZIER, EXAMINING ATTORNEY

CLASS 37—(Continued).

SN 85-277,379. MIDWEST BASEMENT SYSTEMS, INC., DES MOINES, IA. FILED 3-25-2011.

MIDWEST BASEMENT SYSTEMS

THE MARK CONSISTS OF STANDARD CHARACTERS WITHOUT CLAIM TO ANY PARTICULAR FONT, STYLE, SIZE, OR COLOR.

NO CLAIM IS MADE TO THE EXCLUSIVE RIGHT TO USE "BASEMENT", APART FROM THE MARK AS SHOWN. SEC. 2(F).

FOR WATERPROOFING OF BASEMENTS, FOUNDATION CONTRACTOR SERVICES; CONSTRUCTION SERVICES, NAMELY, CONCRETE PAVING, CONCRETE RAISING, CONCRETE REPAIR, WALL REPAIR; CONSTRUCTION AND REPAIR OF BUILDINGS; INSTALLATION OF BUILDING INSULATION; INSTALLATION OF DRAINAGE SYSTEMS (U.S. CLS. 100, 103 AND 106).

FIRST USE 12-31-1995; IN COMMERCE 12-31-1995.
HEATHER SAPP, EXAMINING ATTORNEY

SN 85-277,524. MIDWEST BASEMENT SYSTEMS, INC., DES MOINES, IA. FILED 3-25-2011.



NO CLAIM IS MADE TO THE EXCLUSIVE RIGHT TO USE "BASEMENT", APART FROM THE MARK AS SHOWN.

THE MARK CONSISTS OF THE WORDS "MIDWEST BASEMENT SYSTEMS" WHERE THE WORDS "MIDWEST BASEMENT" ARE ON TOP OF THE WORD "SYSTEMS" AND WHERE THERE IS AN OUTLINE UNDER THE WORD "SYSTEMS" AND UP TO THE TOP OF THE "T" IN "BASEMENT".

SEC. 2(F).

FOR WATERPROOFING OF BASEMENTS, FOUNDATION CONTRACTOR SERVICES; CONSTRUCTION SERVICES, NAMELY, CONCRETE PAVING, CONCRETE RAISING, CONCRETE REPAIR, WALL REPAIR; CONSTRUCTION AND REPAIR OF BUILDINGS; INSTALLATION OF BUILDING INSULATION; INSTALLATION OF DRAINAGE SYSTEMS (U.S. CLS. 100, 103 AND 106).

FIRST USE 12-31-1995; IN COMMERCE 12-31-1995.
HEATHER SAPP, EXAMINING ATTORNEY

CLASS 37—(Continued).

SN 85-283,117. PRESUTTO, INC., LAGUNA NIGUEL, CA. FILED 3-31-2011.

Remodels Ink

THE MARK CONSISTS OF STANDARD CHARACTERS WITHOUT CLAIM TO ANY PARTICULAR FONT, STYLE, SIZE, OR COLOR.

NO CLAIM IS MADE TO THE EXCLUSIVE RIGHT TO USE "REMODELS", APART FROM THE MARK AS SHOWN. FOR BUILDING CONSTRUCTION, REMODELING AND REPAIR (U.S. CLS. 100, 103 AND 106).

FIRST USE 12-30-2002; IN COMMERCE 12-30-2002.
KATHERINE STOIDES, EXAMINING ATTORNEY

SN 85-286,324. COLORADO COMMERCIAL SERVICES, INC., DENVER, CO. FILED 4-5-2011.

Cleaning. Preventing.
Protecting.

THE MARK CONSISTS OF STANDARD CHARACTERS WITHOUT CLAIM TO ANY PARTICULAR FONT, STYLE, SIZE, OR COLOR.

FOR JANITORIAL SERVICES (U.S. CLS. 100, 103 AND 106).

FIRST USE 5-1-2010; IN COMMERCE 5-1-2010.
HEATHER SAPP, EXAMINING ATTORNEY

SN 85-288,813. OHIO BASEMENT SOLUTIONS, LLC, COLUMBUS, OH. FILED 4-7-2011.

Show Your Crack!

THE MARK CONSISTS OF STANDARD CHARACTERS WITHOUT CLAIM TO ANY PARTICULAR FONT, STYLE, SIZE, OR COLOR.

FOR MAINTENANCE AND/OR REPAIR OF CONCRETE AND FOUNDATION CRACKS; BASEMENT WALL REINFORCEMENT SERVICES; BASEMENT WATERPROOFING; INSTALLATION OF SUMP PUMPS AND SUMP PUMP BATTERY BACKUPS (U.S. CLS. 100, 103 AND 106).

FIRST USE 1-25-2011; IN COMMERCE 1-25-2011.
ANGELA DUONG, EXAMINING ATTORNEY

CLASS 37—(Continued).

SN 85-288,948. EAST TEXAS REFRIGERATION COMPANY INC, TYLER, TX. FILED 4-7-2011.



NO CLAIM IS MADE TO THE EXCLUSIVE RIGHT TO USE "EAST TEXAS REFRIGERATION" AND "AIR CONDITIONING & HEATING", APART FROM THE MARK AS SHOWN.

THE MARK CONSISTS OF THE STYLIZED TEXT "ETR EAST TEXAS REFRIGERATION AIR CONDITIONING & HEATING".

FOR INSTALLATION, MAINTENANCE AND REPAIR OF AIR CONDITIONING AND HEATING EQUIPMENT AND SYSTEMS FOR HVAC PURPOSES (U.S. CLS. 100, 103 AND 106).

FIRST USE 4-1-1978; IN COMMERCE 4-1-1978.
AMY HELLA, EXAMINING ATTORNEY

SN 85-289,876. WAHRSAGER, AARON, BELLMORE, NY. FILED 4-8-2011.

Security Doctors

THE MARK CONSISTS OF STANDARD CHARACTERS WITHOUT CLAIM TO ANY PARTICULAR FONT, STYLE, SIZE, OR COLOR.

NO CLAIM IS MADE TO THE EXCLUSIVE RIGHT TO USE "SECURITY", APART FROM THE MARK AS SHOWN.

FOR INSTALLATION AND MAINTENANCE OF SECURITY SYSTEMS (U.S. CLS. 100, 103 AND 106).
ROBIN CHOSID, EXAMINING ATTORNEY

SN 85-291,108. BELLAHEIM, INC., DBA BELLAHEIM HOMES, AUSTIN, TX. FILED 4-9-2011.

BELLAHEIM

THE MARK CONSISTS OF STANDARD CHARACTERS WITHOUT CLAIM TO ANY PARTICULAR FONT, STYLE, SIZE, OR COLOR.

FOR RESIDENTIAL AND COMMERCIAL BUILDING CONSTRUCTION (U.S. CLS. 100, 103 AND 106).
FIRST USE 2-16-2011; IN COMMERCE 2-16-2011.
MARGERY A. TIERNEY, EXAMINING ATTORNEY

CLASS 37—(Continued).

SN 85-292,698. RAGUSA, ANTHONY J., JR., WILLIAMS-VILLE, NY. FILED 4-12-2011.



NO CLAIM IS MADE TO THE EXCLUSIVE RIGHT TO USE "SERVICE", APART FROM THE MARK AS SHOWN.

THE MARK CONSISTS OF THE DESIGN OF A THREE DIMENSIONAL CUBE AND THE WORDING "WHITE BOX SERVICE" TO THE RIGHT OF THE DESIGN.

FOR REPAIR OF CONSUMER ELECTRONICS (U.S. CLS. 100, 103 AND 106).

FIRST USE 9-2-2009; IN COMMERCE 10-0-2009.
DAVID I, EXAMINING ATTORNEY

SN 85-293,146. FURNITURE ROW COLO, LLC, DENVER, CO. FILED 4-12-2011.

PROSPER

THE MARK CONSISTS OF STANDARD CHARACTERS WITHOUT CLAIM TO ANY PARTICULAR FONT, STYLE, SIZE, OR COLOR.

FOR REAL ESTATE DEVELOPMENT IN THE FIELD OF SHOPPING CENTERS AND RETAIL SHOPPING OUTLETS; CONSTRUCTION AND LAND DEVELOPMENT SERVICES, NAMELY, PLANNING, LAYING OUT AND BUILDING OF RESIDENTIAL AND MULTI-USE COMMUNITIES AND COMMERCIAL BUILDINGS FEATURING NEW RESIDENCES, RECREATIONAL FACILITIES, SOCIAL AND COMMUNITY FACILITIES AND MEETING AND CONVENTION CENTERS; RESIDENTIAL AND COMMERCIAL BUILDING CONSTRUCTION (U.S. CLS. 100, 103 AND 106).

ELLEN B. AWRICH, EXAMINING ATTORNEY

SN 85-294,270. AROUND THE TOWN, PALOS HEIGHTS, IL. FILED 4-13-2011.

Around the Town

THE MARK CONSISTS OF STANDARD CHARACTERS WITHOUT CLAIM TO ANY PARTICULAR FONT, STYLE, SIZE, OR COLOR.

FOR HVAC CONTRACTOR SERVICES (U.S. CLS. 100, 103 AND 106).
FIRST USE 12-1-1990; IN COMMERCE 12-1-1990.
JOHN HWANG, EXAMINING ATTORNEY

CLASS 37—(Continued).

SN 85-294,607. AMI AVIATION SERVICES, LLC, SANFORD, FL. FILED 4-13-2011.

AMI AVIATION

THE MARK CONSISTS OF STANDARD CHARACTERS WITHOUT CLAIM TO ANY PARTICULAR FONT, STYLE, SIZE, OR COLOR.

NO CLAIM IS MADE TO THE EXCLUSIVE RIGHT TO USE "AVIATION", APART FROM THE MARK AS SHOWN.

FOR AIRCRAFT MAINTENANCE AND REPAIR SERVICES; AVIONICS INSTALLATION AND REPAIR; REPAIR, MAINTENANCE AND MODIFICATION OF AIRCRAFT; TECHNICAL SUPPORT SERVICES, NAMELY, TECHNICAL ADVICE RELATED TO THE INSTALLATION OF AIRCRAFT PARTS AND COMPONENTS; TECHNICAL SUPPORT SERVICES, NAMELY, TECHNICAL ADVICE RELATED TO THE REPAIR OF AIRCRAFT AND AVIONICS (U.S. CLS. 100, 103 AND 106).

FIRST USE 9-28-2010; IN COMMERCE 11-4-2010.
ALEX KEAM, EXAMINING ATTORNEY

SN 85-294,610. WADDELL, RUXTON, SANTA FE, NM. FILED 4-13-2011.



THE COLOR(S) RED, YELLOW AND BLACK IS/ARE CLAIMED AS A FEATURE OF THE MARK.

THE MARK CONSISTS OF THE LITERAL ELEMENTS CARPETWORKS WHEREIN CARPETWORKS IS WRITTEN IN BLACK COLOR ON ABOVE THE IMAGE OF RED COLOR DIAMOND, INSIDE WHICH THERE IS YELLOW COLOR LIGHTNING AS SHOWN IN THE MARK.

FOR WATER DAMAGE RESTORATION SERVICES; CARPET CLEANING AND REPAIR SERVICES (U.S. CLS. 100, 103 AND 106).

FIRST USE 1-1-1985; IN COMMERCE 1-1-1985.
ALEX KEAM, EXAMINING ATTORNEY

CLASS 37—(Continued).

SN 85-294,916. THE ST. JOE COMPANY, WATERSOUND, FL. FILED 4-14-2011.

ARVIDA

THE MARK CONSISTS OF STANDARD CHARACTERS WITHOUT CLAIM TO ANY PARTICULAR FONT, STYLE, SIZE, OR COLOR.

OWNER OF U.S. REG. NO. 2,948,060.

FOR LAND DEVELOPMENT SERVICES, NAMELY, PLANNING AND LAYING OUT OF RESIDENTIAL AND/OR COMMERCIAL COMMUNITIES; REAL ESTATE DEVELOPMENT; REAL ESTATE SITE SELECTION (U.S. CLS. 100, 103 AND 106).

PAUL F. GAST, EXAMINING ATTORNEY

SN 85-295,649. HOWZ IT FLOWIN INC, BRADENTON, FL. FILED 4-14-2011.

Howz It Flowin

THE MARK CONSISTS OF STANDARD CHARACTERS WITHOUT CLAIM TO ANY PARTICULAR FONT, STYLE, SIZE, OR COLOR.

FOR PLUMBING SERVICES (U.S. CLS. 100, 103 AND 106).

FIRST USE 11-5-2003; IN COMMERCE 11-5-2003.
PATRICIA EVANKO, EXAMINING ATTORNEY

SN 85-299,042. ACCESS ENERGY, LLC, YORBA LINDA, CA. FILED 4-19-2011.

ACCESS ENERGY

THE MARK CONSISTS OF STANDARD CHARACTERS WITHOUT CLAIM TO ANY PARTICULAR FONT, STYLE, SIZE, OR COLOR.

FOR INSTALLATION, REPAIR, AND MAINTENANCE OF ELECTRICITY GENERATORS CONSISTING OF A WASTE HEAT RECOVERY SYSTEM FOR THE OIL AND GAS INDUSTRY (U.S. CLS. 100, 103 AND 106).

DAVID C. REIHNER, EXAMINING ATTORNEY

CLASS 37—(Continued).

SN 85-307,532. GENERAL ELECTRIC COMPANY, FAIRFIELD, CT. FILED 4-28-2011.

CBM-INTERVAL

THE MARK CONSISTS OF STANDARD CHARACTERS WITHOUT CLAIM TO ANY PARTICULAR FONT, STYLE, SIZE, OR COLOR.

FOR GAS TURBINE MAINTENANCE SERVICES AND GAS TURBINE REPAIR SERVICES (U.S. CLS. 100, 103 AND 106).

MICHAEL SOUDERS, EXAMINING ATTORNEY

CLASS 37—(Continued).

SN 85-319,195. INTEGRA LIFESCIENCES CORPORATION, PLAINSBORO, NJ. FILED 5-12-2011.



THE MARK CONSISTS OF FOUR BLOCKS OF DESCENDING SIZE, ARRANGED VERTICALLY.

FOR REPAIR OR MAINTENANCE OF MEDICAL APPARATUS AND INSTRUMENTS (U.S. CLS. 100, 103 AND 106).

FIRST USE 4-30-2011; IN COMMERCE 4-30-2011.

ALYSSA STEEL, EXAMINING ATTORNEY

SN 85-310,534. LAND ROVER, WARWICK, UNITED KINGDOM, FILED 5-3-2011.



SN 85-319,196. INTEGRA LIFESCIENCES CORPORATION, PLAINSBORO, NJ. FILED 5-12-2011.

LIMIT UNCERTAINTY

OWNER OF U.S. REG. NOS. 929,034, 2,100,825 AND OTHERS.

THE MARK CONSISTS OF THE LETTERS "RANGE ROVER" WITH THE WORD "RANGE" DIRECTLY ABOVE THE WORD "ROVER".

FOR AUTOMOTIVE MAINTENANCE AND REPAIR (U.S. CLS. 100, 103 AND 106).

FIRST USE 11-18-2010. THE MARK WAS FIRST USED ANYWHERE IN A DIFFERENT FORM OTHER THAN THAT SOUGHT TO BE REGISTERED AT LEAST AS EARLY AS 03/21/1989. ; IN COMMERCE 11-18-2010, THE MARK WAS FIRST USED IN COMMERCE IN A DIFFERENT FORM OTHER THAN THAT SOUGHT TO BE REGISTERED AT LEAST AS EARLY AS 03/21/1989..

EMILY CARLSEN, EXAMINING ATTORNEY

THE MARK CONSISTS OF STANDARD CHARACTERS WITHOUT CLAIM TO ANY PARTICULAR FONT, STYLE, SIZE, OR COLOR.

FOR REPAIR OR MAINTENANCE OF MEDICAL APPARATUS AND INSTRUMENTS (U.S. CLS. 100, 103 AND 106).

FIRST USE 4-30-2011; IN COMMERCE 4-30-2011.

ALYSSA STEEL, EXAMINING ATTORNEY

CLASS 37—(Continued).

SN 85-319,356. ACCESS ENERGY, LLC, YORBA LINDA, CA. FILED 5-12-2011.



THE MARK CONSISTS OF STYLIZED LETTERS A AND E WITH ARROWS AT THE TIP OF THE A AND E AND THE WORDS ACCESS ENERGY BELOW.

FOR INSTALLATION, REPAIR, AND MAINTENANCE OF ELECTRICITY GENERATORS CONSISTING OF A WASTE HEAT RECOVERY SYSTEM FOR THE OIL AND GAS INDUSTRY (U.S. CLS. 100, 103 AND 106).

DAVID C. REIHNER, EXAMINING ATTORNEY

CLASS 38—(Continued).

SN 85-020,033. GLOBE TELECOM, INC., MANDALUYONG CITY, PHILIPPINES, FILED 4-21-2010.

PRIORITY CLAIMED UNDER SEC. 44(D) ON PHILIPPINES APPLICATION NO. 42010002560, FILED 3-8-2010, REG. NO. 42010002560, DATED 10-21-2010, EXPIRES 10-21-2020.

THE COLOR(S) RED AND DARK RED IS/ARE CLAIMED AS A FEATURE OF THE MARK.

THE MARK CONSISTS OF THE WORDING "MUZTA!" IN THE COLOR RED AND DARK RED.

THE WORDING "MUZTA" HAS NO MEANING IN A FOREIGN LANGUAGE.

FOR VOICE OVER INTERNET PROTOCOL (VOIP) SERVICES (U.S. CLS. 100, 101 AND 104).

MARLENE BELL, EXAMINING ATTORNEY

SN 85-038,022. EAGLE TELECONFERENCING SERVICES, INC., NEW YORK, NY. FILED 5-13-2010.

EAGLE MESSAGING

THE MARK CONSISTS OF STANDARD CHARACTERS WITHOUT CLAIM TO ANY PARTICULAR FONT, STYLE, SIZE, OR COLOR.

OWNER OF U.S. REG. NOS. 2,761,043 AND 3,573,499.

NO CLAIM IS MADE TO THE EXCLUSIVE RIGHT TO USE "MESSAGING", APART FROM THE MARK AS SHOWN.

FOR TELECOMMUNICATION SERVICES, NAMELY, PROVIDING ADVANCED CALLING FEATURES (U.S. CLS. 100, 101 AND 104).

FIRST USE 12-7-2007; IN COMMERCE 12-7-2007.

ELLEN BURNS, EXAMINING ATTORNEY

CLASS 38—COMMUNICATION

SN 77-063,360. LODGENET INTERACTIVE CORPORATION, SIOUX FALLS, SD. FILED 12-13-2006.

THE MARK CONSISTS OF STANDARD CHARACTERS WITHOUT CLAIM TO ANY PARTICULAR FONT, STYLE, SIZE, OR COLOR.

NO CLAIM IS MADE TO THE EXCLUSIVE RIGHT TO USE "HD", APART FROM THE MARK AS SHOWN.

FOR TELEVISION TRANSMISSION SERVICES FOR USE IN HOTELS, INNS AND TEMPORARY LODGING ESTABLISHMENTS; VIDEO ON-DEMAND TRANSMISSION SERVICES FOR USE IN HOTELS, INNS AND TEMPORARY LODGING ESTABLISHMENTS; PROVIDING INTERNET ACCESS VIA THE IN-ROOM TELEVISION SYSTEM IN A HOTEL, INN AND TEMPORARY LODGING ESTABLISHMENT; TRANSMISSION OF INFORMATION TO GUESTS AND TRANSMISSION OF SERVICE REQUESTS FROM GUESTS, ALL VIA THE IN-ROOM TELEVISION SYSTEM IN A HOTEL, INN AND TEMPORARY LODGING ESTABLISHMENT (U.S. CLS. 100, 101 AND 104).

DORITT L. CARROLL, EXAMINING ATTORNEY

SN 85-091,773. ASSOCIATION OF UNIVERSITIES FOR RESEARCH IN ASTRONOMY, INC., WASHINGTON, DC. FILED 7-23-2010.

ASK MR. SUNSPOT

THE MARK CONSISTS OF STANDARD CHARACTERS WITHOUT CLAIM TO ANY PARTICULAR FONT, STYLE, SIZE, OR COLOR.

SEC. 2(F).

FOR PROVIDING AN ON-LINE FORUM FOR THE PUBLIC TO OBTAIN INFORMATION CONCERNING THE SUN AND ASTRONOMY FROM THE NATIONAL SOLAR OBSERVATORY (U.S. CLS. 100, 101 AND 104).

FIRST USE 3-31-1996; IN COMMERCE 3-31-1996.

RAMONA ORTIGA, EXAMINING ATTORNEY

CLASS 38—(Continued).

SN 85-091,976. DEEP BLUE DATA CORPORATION, HIGHLAND PARK, IL. FILED 7-23-2010.

CLASS 38—(Continued).

SN 85-137,620. REV MEDIA MARKETING LLC, MILFORD, OH. FILED 9-24-2010.

DEEP BLUE DATA

ADDICTED TO OVERDRIVE

THE MARK CONSISTS OF STANDARD CHARACTERS WITHOUT CLAIM TO ANY PARTICULAR FONT, STYLE, SIZE, OR COLOR.

NO CLAIM IS MADE TO THE EXCLUSIVE RIGHT TO USE "DATA", APART FROM THE MARK AS SHOWN.

FOR COMMUNICATION SERVICES, NAMELY, TRANSMISSION OF VOICE, AUDIO, GRAPHICS, IMAGES, VIDEO AND DATA BY TELECOMMUNICATIONS NETWORKS, WIRELESS COMMUNICATION NETWORKS, THE INTERNET, INFORMATION SERVICES NETWORKS AND DATA NETWORKS; PROVIDING VOICE COMMUNICATION SERVICES VIA THE INTERNET; PROVIDING INTERNET ACCESS VIA BROADBAND OPTICAL OR WIRELESS NETWORKS; PROVIDING MULTIPLE-USER ACCESS TO A GLOBAL COMPUTER NETWORK; CONSULTING IN THE FIELD OF TELECOMMUNICATIONS; WIRELESS BROADBAND COMMUNICATION SERVICES (U.S. CLS. 100, 101 AND 104).

SUE LAWRENCE, EXAMINING ATTORNEY

THE MARK CONSISTS OF STANDARD CHARACTERS WITHOUT CLAIM TO ANY PARTICULAR FONT, STYLE, SIZE, OR COLOR.

FOR CONSULTATION IN THE FIELD OF COMMUNICATION; AUDIO, TELEVISION AND RADIO BROADCASTING CONCERNING LIFESTYLE, STRESS AND TIME MANAGEMENT, WELLNESS, PERSONAL EMPOWERMENT, MOTIVATION, LEADERSHIP, CONFLICT RESOLUTION AND CULTURE; PROVIDING ON-LINE CHAT ROOMS FOR SOCIAL NETWORKING IN THE FIELD OF LIFESTYLE, STRESS AND TIME MANAGEMENT, WELLNESS, PERSONAL EMPOWERMENT, MOTIVATION, LEADERSHIP, CONFLICT RESOLUTION AND CULTURE (U.S. CLS. 100, 101 AND 104).

SAMUEL E. SHARPER JR., EXAMINING ATTORNEY

SN 85-125,163. REV MEDIA MARKETING LLC, MILFORD, OH. FILED 9-8-2010.

SN 85-164,990. GRABOWSKI, SZYMON, GDYNIA, POLAND, FILED 10-29-2010.

ONE CLICK SOCIETY

CLICKTRAINING

THE MARK CONSISTS OF STANDARD CHARACTERS WITHOUT CLAIM TO ANY PARTICULAR FONT, STYLE, SIZE, OR COLOR.

NO CLAIM IS MADE TO THE EXCLUSIVE RIGHT TO USE "SOCIETY", APART FROM THE MARK AS SHOWN.

FOR CONSULTATION IN THE FIELD OF COMMUNICATION (U.S. CLS. 100, 101 AND 104).

SAMUEL E. SHARPER JR., EXAMINING ATTORNEY

THE MARK CONSISTS OF STANDARD CHARACTERS WITHOUT CLAIM TO ANY PARTICULAR FONT, STYLE, SIZE, OR COLOR.

FOR PROVIDING INTERNET CHAT ROOMS; STREAMING OF AUDIO, VISUAL AND AUDIOVISUAL MATERIAL VIA A GLOBAL COMPUTER NETWORK (U.S. CLS. 100, 101 AND 104).

DAWN FELDMAN, EXAMINING ATTORNEY

CLASS 38—(Continued).

SN 85-180,355. INDEPENDENT TELEVISION SERVICE, INC., SAN FRANCISCO, CA. FILED 11-18-2010.



OWNER OF U.S. REG. NO. 2,154,718.
THE MARK CONSISTS OF THE LETTERS "I T V S" IN BRACKETS.

FOR VIDEO STREAMING SERVICES AND TRANSMISSION SERVICES OF AUDIO VISUAL WORKS VIA A GLOBAL COMPUTER NETWORK, INTERNET, CABLE, BROADBAND, COPPER, AND OPTICAL AND WIRELESS NETWORKS; BROADCASTING TRANSMISSIONS OF AUDIO VISUAL WORKS, MESSAGES AND INFORMATION VIA A GLOBAL COMPUTER NETWORK, INTERNET, CABLE, BROADBAND, COPPER, OPTICAL AND WIRELESS NETWORKS (U.S. CLS. 100, 101 AND 104).

FIRST USE 9-30-2006; IN COMMERCE 9-30-2006.
EUGENIA MARTIN, EXAMINING ATTORNEY

SN 85-243,089. CBS BROADCASTING INC., NEW YORK, NY. FILED 2-15-2011.

CBS SPORTS NETWORK

THE MARK CONSISTS OF STANDARD CHARACTERS WITHOUT CLAIM TO ANY PARTICULAR FONT, STYLE, SIZE, OR COLOR.

OWNER OF U.S. REG. NOS. 852,481, 3,616,830 AND OTHERS.

NO CLAIM IS MADE TO THE EXCLUSIVE RIGHT TO USE "SPORTS NETWORK", APART FROM THE MARK AS SHOWN.

FOR BROADCASTING SERVICES, NAMELY TRANSMITTING, DOWNLOADING AND STREAMING DIGITAL AUDIO, VIDEO, GRAPHICS, VOICE DATA IMAGES, SIGNALS, TEXT AND DATA RENDERED THROUGH THE MEDIA OF TELEVISION, CABLE, SATELLITE, RADIO, TELEPHONE AND BROADBAND SYSTEMS, AND VIA THE INTERNET AND PORTABLE AND WIRELESS COMMUNICATION DEVICES; PROVIDING AN ONLINE COMMUNITY, NAMELY PROVIDING ACCESS TO DATABASES AND TRANSMISSION AND STREAMING OF DIGITAL AUDIO, VIDEO, GRAPHICS, TEXT AND DATA ON THE INTERNET SERVICE ENABLING TRANSMISSION, DOWNLOADING AND STREAMING OF DIGITAL AUDIO, VIDEO, GRAPHICS, TEXT AND DATA (U.S. CLS. 100, 101 AND 104).

DAVID TOOLEY, EXAMINING ATTORNEY

CLASS 38—(Continued).

SN 85-256,001. ISADIS, LLC, MIAMI, FL. FILED 3-2-2011.



THE COLOR(S) BLACK, DARK GREY, GREY, YELLOW, LIGHT BLUE, GREEN, PLUM, RED AND VIOLET IS/ARE CLAIMED AS A FEATURE OF THE MARK.

THE MARK CONSISTS OF A TELEVISION SET WITH A DARK GREY FRAME, SURROUNDING A GREY FRAME, WITH SIX COLUMNS OF DIFFERENT COLORS, STARTING FROM THE LEFT: YELLOW, LIGHT BLUE, GREEN, PLUM, RED AND VIOLET. ON TOP OF THE TELEVISION SET ARE A PAIR OF ANTENNAE IN BLACK. BELOW THE TELEVISION DESIGN APPEARS THE LETTERING WREAL IN BLACK.

FOR BROADCASTING SERVICES AND PROVISION OF TELECOMMUNICATION ACCESS TO VIDEO AND AUDIO CONTENT PROVIDED VIA A VIDEO-ON-DEMAND SERVICE VIA THE INTERNET; COMMUNICATIONS SERVICES, NAMELY, TRANSMITTING STREAMED SOUND AND AUDIO-VISUAL RECORDINGS VIA THE INTERNET; STREAMING OF VIDEO MATERIAL ON THE INTERNET (U.S. CLS. 100, 101 AND 104).

ELIZABETH KAJUBI, EXAMINING ATTORNEY

SN 85-256,126. CBS BROADCASTING INC., NEW YORK, NY. FILED 3-2-2011.



OWNER OF U.S. REG. NOS. 852,481, 3,616,830 AND OTHERS.

NO CLAIM IS MADE TO THE EXCLUSIVE RIGHT TO USE "SPORTS NETWORK", APART FROM THE MARK AS SHOWN.

THE MARK CONSISTS OF AN EYE WITH THE WORDS "CBS SPORTS" ABOVE A CENTER LINE AND THE WORD "NETWORK" BELOW THE CENTER LINE.

FOR BROADCASTING SERVICES, NAMELY TRANSMITTING, DOWNLOADING AND STREAMING DIGITAL AUDIO, VIDEO, GRAPHICS, VOICE DATA IMAGES, SIGNALS, TEXT AND DATA RENDERED THROUGH THE MEDIA OF TELEVISION, CABLE, SATELLITE, RADIO, TELEPHONE AND BROADBAND SYSTEMS, AND VIA THE INTERNET AND PORTABLE AND WIRELESS COMMUNICATION DEVICES; PROVIDING AN ONLINE COMMUNITY, NAMELY PROVIDING ACCESS TO DATABASES AND TRANSMISSION AND STREAMING OF DIGITAL AUDIO, VIDEO, GRAPHICS, TEXT AND DATA ON THE INTERNET SERVICE ENABLING TRANSMISSION, DOWNLOADING AND STREAMING OF DIGITAL AUDIO, VIDEO, GRAPHICS, TEXT AND DATA (U.S. CLS. 100, 101 AND 104).

DAVID TOOLEY, EXAMINING ATTORNEY

CLASS 38—(Continued).

SN 85-266,606. MIDCONTINENT COMMUNICATIONS, MINNEAPOLIS, MN. FILED 3-14-2011.



OWNER OF U.S. REG. NO. 2,167,344.
NO CLAIM IS MADE TO THE EXCLUSIVE RIGHT TO USE "STREAM", APART FROM THE MARK AS SHOWN.
THE MARK CONSISTS OF AN "X"-SHAPED IMAGE COMPRISED OF SMALL SQUARES, EXTENDING INTO THE PAGE IN PERSPECTIVE, INTERPOSED BETWEEN THE WORDS "MIDCONET" AND "STREAM".
FOR TELECOMMUNICATIONS SERVICES, NAMELY, PROVIDING HIGH-SPEED ACCESS TO THE INTERNET AND OTHER ELECTRONIC COMMUNICATIONS NETWORKS (U.S. CLS. 100, 101 AND 104).
ERIN FALK, EXAMINING ATTORNEY

SN 85-271,938. SYNIVERSE TECHNOLOGIES, INC., TAMPA, FL. FILED 3-21-2011.

LTE LET'S TALK EVOLUTION

THE MARK CONSISTS OF STANDARD CHARACTERS WITHOUT CLAIM TO ANY PARTICULAR FONT, STYLE, SIZE, OR COLOR.
NO CLAIM IS MADE TO THE EXCLUSIVE RIGHT TO USE "LTE" AND "EVOLUTION", APART FROM THE MARK AS SHOWN.
FOR ONLINE INFORMATIONAL SERVICES IN THE FIELD OF TELECOMMUNICATIONS, NAMELY, LONG TERM EVOLUTION MOBILE COMMUNICATIONS TECHNOLOGY (U.S. CLS. 100, 101 AND 104).
ANDREA HACK, EXAMINING ATTORNEY

SN 85-271,953. SYNIVERSE TECHNOLOGIES, INC., TAMPA, FL. FILED 3-21-2011.

LET'S TALK EVOLUTION

THE MARK CONSISTS OF STANDARD CHARACTERS WITHOUT CLAIM TO ANY PARTICULAR FONT, STYLE, SIZE, OR COLOR.
NO CLAIM IS MADE TO THE EXCLUSIVE RIGHT TO USE "EVOLUTION", APART FROM THE MARK AS SHOWN.
FOR ONLINE INFORMATIONAL SERVICES IN THE FIELD OF TELECOMMUNICATIONS, NAMELY, LONG TERM EVOLUTION MOBILE COMMUNICATIONS TECHNOLOGY (U.S. CLS. 100, 101 AND 104).
ANDREA HACK, EXAMINING ATTORNEY

CLASS 38—(Continued).

SN 85-274,120. CARTWRIGHT, JEFFREY, R. CEDAR PARK, TX. FILED 3-23-2011.

TV Werx

THE MARK CONSISTS OF STANDARD CHARACTERS WITHOUT CLAIM TO ANY PARTICULAR FONT, STYLE, SIZE, OR COLOR.
NO CLAIM IS MADE TO THE EXCLUSIVE RIGHT TO USE "TV", APART FROM THE MARK AS SHOWN.
FOR INTERNET PROTOCOL TELEVISION (IPTV) TRANSMISSION SERVICES (U.S. CLS. 100, 101 AND 104).
FIRST USE 3-3-2011; IN COMMERCE 3-3-2011.
REBECCA GILBERT, EXAMINING ATTORNEY

SN 85-274,845. SEGOVIA, INC., HERNDON, VA. FILED 3-23-2011.

BGAN SECURE TERRESTRIAL ACCESS

THE MARK CONSISTS OF STANDARD CHARACTERS WITHOUT CLAIM TO ANY PARTICULAR FONT, STYLE, SIZE, OR COLOR.
NO CLAIM IS MADE TO THE EXCLUSIVE RIGHT TO USE "SECURE TERRESTRIAL ACCESS", APART FROM THE MARK AS SHOWN.
FOR SATELLITE COMMUNICATION SERVICES AND SECURE TERRESTRIAL COMMUNICATIONS SERVICES, NAMELY, TRANSMISSION OF INFORMATION BY SECURE ELECTRONIC COMMUNICATION NETWORKS; TELECOMMUNICATIONS SERVICES, NAMELY, SATELLITE TRANSMISSION OF VOICE AND DATA; SECURE TERRESTRIAL CONNECTIVITY, NAMELY, PROVIDING SECURE TELECOMMUNICATION CONNECTIVITY SERVICES FOR TRANSFER OF IMAGES, MESSAGES, AUDIO, VISUAL AND AUDIO-VISUAL MULTIMEDIA WORKS (U.S. CLS. 100, 101 AND 104).
FIRST USE 9-28-2007; IN COMMERCE 9-28-2007.
RUDY R. SINGLETON, EXAMINING ATTORNEY

CLASS 38—(Continued).

SN 85-276,763. PROFESSIONAL ARTS CONSORTIUM, INC., BOSTON, MA. FILED 3-25-2011.



THE COLOR(S) RED, BLUE, GREEN, AND PURPLE IS/ ARE CLAIMED AS A FEATURE OF THE MARK.

THE MARK CONSISTS OF FOUR, DISTINCT, SYMMETRIC LENS SHAPES, INDIVIDUALLY COLORED RED, BLUE, GREEN AND PURPLE, ORGANIZED IN A CIRCULAR PATTERN

FOR PROVIDING ONLINE FORUMS AND BULLETIN BOARDS FOR TRANSMISSION OF MESSAGES AMONG COMPUTER USERS CONCERNING CLASSIFIED LISTINGS AND LISTINGS FOR ANNOUNCEMENTS, EVENTS, CONCERTS, CLASSES, CLASS MANAGEMENT, MEETINGS, ACTIVITIES, HOUSING, REAL ESTATE, ROOMMATES, RENTALS, FOR SALE ADVERTISEMENTS, SERVICES, AND INFORMATION ON A WIDE VARIETY OF TOPICS OF GENERAL INTEREST TO THE PUBLIC; PROVIDING ON-LINE FORUMS AND DISCUSSION GROUPS FOR TRANSMISSION OF MESSAGES AMONG COMPUTER USERS CONCERNING ARTS, LEISURE, ENTERTAINMENT, CLASSES, CLASS MANAGEMENT, WORK, AND INFORMATION ON A WIDE VARIETY OF TOPICS OF GENERAL INTEREST TO THE PUBLIC; ELECTRONIC MAIL SUBSCRIPTION SERVICES; AND ELECTRONIC TRANSMISSION OF MESSAGES, DATA AND IMAGES (U.S. CLS. 100, 101 AND 104).

FIRST USE 2-1-2010; IN COMMERCE 2-1-2010.

SAMUEL E. SHARPER JR., EXAMINING ATTORNEY

SN 85-276,790. MAVERICK MEDIA OF SANTA ROSA, LLC, SANTA ROSA, CA. FILED 3-25-2011.

HOT 101.7

THE MARK CONSISTS OF STANDARD CHARACTERS WITHOUT CLAIM TO ANY PARTICULAR FONT, STYLE, SIZE, OR COLOR.

NO CLAIM IS MADE TO THE EXCLUSIVE RIGHT TO USE "101.7", APART FROM THE MARK AS SHOWN.

FOR RADIO BROADCASTING SERVICES, STREAMING OF AUDIO MATERIAL ON THE INTERNET (U.S. CLS. 100, 101 AND 104).

FIRST USE 3-24-2011; IN COMMERCE 3-24-2011.

JENNIFER MARTIN, EXAMINING ATTORNEY

CLASS 38—(Continued).

SN 85-277,345. PAPPAS, MICHAEL J., DENVER, CO. FILED 3-25-2011.

Voice of America Jazz Hour

THE MARK CONSISTS OF STANDARD CHARACTERS WITHOUT CLAIM TO ANY PARTICULAR FONT, STYLE, SIZE, OR COLOR.

NO CLAIM IS MADE TO THE EXCLUSIVE RIGHT TO USE "AMERICA JAZZ HOUR", APART FROM THE MARK AS SHOWN.

FOR AUDIO AND VIDEO BROADCASTING SERVICES OVER THE INTERNET; AUDIO BROADCASTING; BROADBAND RADIO COMMUNICATION SERVICES; BROADCASTING OF RADIO PROGRAMMES; INTERNET BROADCASTING SERVICES; INTERNET RADIO BROADCASTING SERVICES; RADIO BROADCASTING; RADIO BROADCASTING INFORMATION; RADIO COMMUNICATION; RADIO PROGRAM BROADCASTING; RADIO PROGRAMME BROADCASTING (U.S. CLS. 100, 101 AND 104).

CARYN GLASSER, EXAMINING ATTORNEY

SN 85-284,545. DISASTER INC., ST PETERSBURG, FL. FILED S.R. 4-2-2011; AM. P.R. 7-5-2011.

give tv

THE MARK CONSISTS OF STANDARD CHARACTERS WITHOUT CLAIM TO ANY PARTICULAR FONT, STYLE, SIZE, OR COLOR.

NO CLAIM IS MADE TO THE EXCLUSIVE RIGHT TO USE "TV", APART FROM THE MARK AS SHOWN.

FOR TELECOMMUNICATION SERVICES, NAMELY, BROADCASTING SERVICES, NAMELY, AUDIO BROADCASTING, VIDEO BROADCASTING, BROADCASTING PROGRAMS VIA A GLOBAL COMPUTER NETWORK; COMMUNICATION SERVICES, NAMELY, STREAMING OF AUDIO MATERIAL ON THE INTERNET, STREAMING OF VIDEO MATERIAL ON THE INTERNET; ELECTRONIC TRANSMISSION OF MESSAGES AND DATA; WEBCASTING SERVICES; PROVIDING ON-LINE FORUMS FOR TRANSMISSION OF MESSAGES AMONG COMPUTER USERS, ALL IN THE FIELD OF PHILANTHROPY AND GIVING AND CHARITY AND DONATION (U.S. CLS. 100, 101 AND 104).

FIRST USE 2-26-2011; IN COMMERCE 2-26-2011.

EDWARD NELSON, EXAMINING ATTORNEY

CLASS 38—(Continued).

SN 85-292,279. BIASBOOK.COM, GRAND RAPIDS, MI.
FILED 4-11-2011.

Biasbook

THE MARK CONSISTS OF STANDARD CHARACTERS WITHOUT CLAIM TO ANY PARTICULAR FONT, STYLE, SIZE, OR COLOR.

FOR PROVIDING ON-LINE FORUMS FOR TRANSMISSION OF MESSAGES AMONG COMPUTER USERS (U.S. CLS. 100, 101 AND 104).

ANNE MADDEN, EXAMINING ATTORNEY

SN 85-293,506. MOBILE CONTENT VENTURE LLC, NEW YORK, NY. FILED 4-12-2011.

DYLE

THE MARK CONSISTS OF STANDARD CHARACTERS WITHOUT CLAIM TO ANY PARTICULAR FONT, STYLE, SIZE, OR COLOR.

FOR BROADCASTING AND STREAMING OF AUDIO, VISUAL, AND AUDIO-VISUAL MEDIA CONTENT VIA GLOBAL COMMUNICATION NETWORKS, GLOBAL COMPUTER NETWORKS, AND WIRELESS NETWORKS; TRANSMISSION OF SOUND, VIDEO, DATA, IMAGES, SIGNALS, MESSAGES AND INFORMATION; VIDEO-ON-DEMAND TRANSMISSION SERVICES; PODCASTING SERVICES; WEBCASTING SERVICES; WEB MESSAGING SERVICES; PROVIDING ACCESS TO ONLINE FORUMS, CHAT ROOMS, AND BLOGS; ELECTRONIC BULLETIN BOARD SERVICES; PROVIDING INTERNET CHAT ROOMS; PROVIDING ONLINE LISTSERVICES FOR TRANSMISSION OF MESSAGES FEATURING CURRENT EVENTS REPORTING, ENTERTAINMENT, SPORTS, WEATHER, COMEDY, DRAMA, DOCUMENTARIES, ACTION, ADVENTURE, MUSIC, AND MUSIC VIDEOS (U.S. CLS. 100, 101 AND 104).

DOUGLAS LEE, EXAMINING ATTORNEY

SN 85-294,732. APERSONA, DBA APERSONA INC, RALEIGH, NC. FILED 4-13-2011.

aPersona

THE MARK CONSISTS OF STANDARD CHARACTERS WITHOUT CLAIM TO ANY PARTICULAR FONT, STYLE, SIZE, OR COLOR.

FOR COMMUNICATION SERVICES, NAMELY, PROVIDING ELECTRONIC TRANSMISSION OF INFORMATION STORED IN A DATABASE VIA INTERACTIVELY COMMUNICATING COMPUTER SYSTEMS (U.S. CLS. 100, 101 AND 104).

DAWN FELDMAN, EXAMINING ATTORNEY

CLASS 38—(Continued).

SN 85-296,277. HOME BOX OFFICE, INC., NEW YORK, NY.
FILED 4-15-2011.



OWNER OF U.S. REG. NOS. 1,349,993, 3,904,923 AND OTHERS.

THE MARK CONSISTS OF "CINEMAX" IN SLANTED BLOCK LETTERS ON A QUADRILATERAL BACKGROUND.

FOR BROADCASTING OF TELEVISION PROGRAMS; CABLE TELEVISION BROADCASTING SERVICES; ELECTRONIC TRANSMISSION, BROADCASTING AND DELIVERY OF AUDIO, VIDEO AND MULTIMEDIA ENTERTAINMENT CONTENT INCLUDING TEXT, DATA, IMAGES, AUDIO, VIDEO AND AUDIOVISUAL FILES BY MEANS OF THE INTERNET, WIRELESS COMMUNICATION, ELECTRONIC COMMUNICATIONS NETWORKS AND COMPUTER NETWORKS; ELECTRONIC TRANSMISSION AND STREAMING OF DIGITAL MEDIA CONTENT FOR OTHERS VIA GLOBAL AND LOCAL COMPUTER NETWORKS; ELECTRONIC TRANSMISSION OF VOICE, DATA AND IMAGES BY TELEVISION AND VIDEO BROADCASTING (U.S. CLS. 100, 101 AND 104).

SUSAN RICHARDS, EXAMINING ATTORNEY

SN 85-296,680. AUTHENTEC, INC., MELBOURNE, FL.
FILED 4-15-2011.

FIDO

THE MARK CONSISTS OF STANDARD CHARACTERS WITHOUT CLAIM TO ANY PARTICULAR FONT, STYLE, SIZE, OR COLOR.

FOR PROVIDING ELECTRONIC TRANSMISSION OF CREDIT CARD, DEBIT CARD, CARDLESS ELECTRONIC PAYMENT OR IDENTIFICATION CARD TRANSACTION DATA AND ELECTRONIC PAYMENT DATA VIA A GLOBAL COMPUTER NETWORK (U.S. CLS. 100, 101 AND 104).

ANDREA HACK, EXAMINING ATTORNEY

CLASS 38—(Continued).

SN 85-300,072. L1 TECHNOLOGIES, INC., SAN DIEGO, CA. FILED 4-20-2011.

IGOLF TV

THE MARK CONSISTS OF STANDARD CHARACTERS WITHOUT CLAIM TO ANY PARTICULAR FONT, STYLE, SIZE, OR COLOR.

OWNER OF U.S. REG. NOS. 3,926,653, 3,948,766 AND OTHERS.

NO CLAIM IS MADE TO THE EXCLUSIVE RIGHT TO USE "TV", APART FROM THE MARK AS SHOWN.

FOR INTERNET PROTOCOL TELEVISION (IPTV) TRANSMISSION SERVICES; VIDEO BROADCASTING SERVICES OVER THE INTERNET OR OTHER COMMUNICATIONS NETWORK FEATURING THE UPLOADED, POSTED AND TAGGED VIDEOS OF OTHERS; VIDEO BROADCASTING SERVICES VIA THE INTERNET; VIDEO TRANSMISSION OVER DIGITAL NETWORKS (U.S. CLS. 100, 101 AND 104).

TAMARA FRAZIER, EXAMINING ATTORNEY

SN 85-320,005. TURNER NETWORK TELEVISION, INC., ATLANTA, GA. FILED 5-13-2011.

UNLOCK THE DRAMA

THE MARK CONSISTS OF STANDARD CHARACTERS WITHOUT CLAIM TO ANY PARTICULAR FONT, STYLE, SIZE, OR COLOR.

FOR STREAMING OF AUDIO, VISUAL, AND AUDIO-VISUAL MATERIAL VIA A GLOBAL COMPUTER NETWORK (U.S. CLS. 100, 101 AND 104).

FIRST USE 5-26-2010; IN COMMERCE 5-26-2010.

ANNE E. GUSTASON, EXAMINING ATTORNEY

SN 85-322,749. UNIVISION COMMUNICATIONS INC., LOS ANGELES, CA. FILED 5-17-2011.

TU RADIO

THE MARK CONSISTS OF STANDARD CHARACTERS WITHOUT CLAIM TO ANY PARTICULAR FONT, STYLE, SIZE, OR COLOR.

THE ENGLISH TRANSLATION OF "TU RADIO" IN THE MARK IS "YOUR RADIO".

FOR STREAMING OF AUDIO CONTENT OVER MOBILE DEVICES AND OVER THE INTERNET (U.S. CLS. 100, 101 AND 104).

ZACHARY BELLO, EXAMINING ATTORNEY

CLASS 38—(Continued).

SN 85-337,495. BRIGHT HOUSE NETWORKS LLC, EAST SYRACUSE, NY. FILED 6-3-2011.

MI MEXICO

THE MARK CONSISTS OF STANDARD CHARACTERS WITHOUT CLAIM TO ANY PARTICULAR FONT, STYLE, SIZE, OR COLOR.

NO CLAIM IS MADE TO THE EXCLUSIVE RIGHT TO USE "MEXICO", APART FROM THE MARK AS SHOWN. THE ENGLISH TRANSLATION OF "MI" IN THE MARK IS "MY".

FOR INTERNATIONAL TELEPHONE CALLING PLAN SERVICES (U.S. CLS. 100, 101 AND 104).

FIRST USE 3-1-2008; IN COMMERCE 3-1-2008.

ERIN FALK, EXAMINING ATTORNEY

SN 85-975,358. BENCHMARK SOLUTIONS HOLDINGS INC., NEW YORK, NY. FILED 6-28-2010.

OpenX

THE MARK CONSISTS OF STANDARD CHARACTERS WITHOUT CLAIM TO ANY PARTICULAR FONT, STYLE, SIZE, OR COLOR.

FOR ELECTRONIC DATA INTERCHANGE (EDI) ALLOWING PARTICIPANTS TO DISSEMINATE INDICATIONS OF INTEREST ACROSS ALL FINANCIAL SERVICE ASSET CLASSES, DEVELOP AND MAINTAIN LIVE FIXED INCOME AND DERIVATIVE MARKETS, AND ACCESS QUOTATIONS AND ORDERS PROVIDED TO FINANCIAL INTERMEDIARIES AND INSTITUTIONAL INVESTORS, NAMELY, ASSET MANAGERS, HEDGE FUNDS, REGISTERED INDEPENDENT ADVISORS AND BROKER DEALERS (U.S. CLS. 100, 101 AND 104).

BARBARA BROWN, EXAMINING ATTORNEY

CLASS 39—TRANSPORTATION AND STORAGE

SN 77-933,306. ALTA EQUIPMENT COMPANY, INC., WIXOM, MI. FILED 2-11-2010.

Alta Rents

THE MARK CONSISTS OF STANDARD CHARACTERS WITHOUT CLAIM TO ANY PARTICULAR FONT, STYLE, SIZE, OR COLOR.

SUBJECT TO CONCURRENT USE PROCEEDING WITH REG. NO. 3662246. APPLICANT CLAIMS EXCLUSIVE RIGHT TO USE THE MARK IN THE AREA COMPRISING

CLASS 39—(Continued).

THE STATES OF ALABAMA, ARKANSAS, CONNECTICUT, DELAWARE, FLORIDA, GEORGIA, ILLINOIS, IOWA, KANSAS, KENTUCKY, LOUISIANA, MAINE, MARYLAND, MASSACHUSETTS, MICHIGAN, MINNESOTA, MISSISSIPPI, MISSOURI, NEBRASKA, NEW HAMPSHIRE, NEW JERSEY, NEW YORK, NORTH CAROLINA, NORTH DAKOTA, OHIO, OKLAHOMA, PENNSYLVANIA, RHODE ISLAND, SOUTH CAROLINA, SOUTH DAKOTA, TENNESSEE, VERMONT, VIRGINIA, WEST VIRGINIA AND WISCONSIN.

OWNER OF U.S. REG. NOS. 2,598,846 AND 2,705,077.

NO CLAIM IS MADE TO THE EXCLUSIVE RIGHT TO USE "RENTS", APART FROM THE MARK AS SHOWN.

THE ENGLISH TRANSLATION OF "ALTA" IN THE MARK IS HIGH.

FOR LEASING OF TRUCKS (U.S. CLS. 100 AND 105).

FIRST USE 11-1-2010; IN COMMERCE 11-1-2010.

CHRISTOPHER BUONGIORNO, EXAMINING ATTORNEY

SN 77-982,254. LUCID PATENT, LLC, MINNEAPOLIS, MN. FILED 12-5-2007.

LUCID PATENT

THE MARK CONSISTS OF STANDARD CHARACTERS WITHOUT CLAIM TO ANY PARTICULAR FONT, STYLE, SIZE, OR COLOR.

NO CLAIM IS MADE TO THE EXCLUSIVE RIGHT TO USE "PATENT", APART FROM THE MARK AS SHOWN.

FOR ELECTRONIC STORAGE OF DATA AND INFORMATION IN THE FIELD OF LEGAL AFFAIRS (U.S. CLS. 100 AND 105).

SARA BENJAMIN, EXAMINING ATTORNEY

SN 79-080,320. CARGOPLAN; VERWALTUNGSSELLSCHAFT M.B.H., AUSTRIA, FILED 12-11-2009.

CARGOMIND

THE MARK CONSISTS OF STANDARD CHARACTERS WITHOUT CLAIM TO ANY PARTICULAR FONT, STYLE, SIZE, OR COLOR.

OWNER OF INTERNATIONAL REGISTRATION 1032585 DATED 12-11-2009, EXPIRES 12-11-2019.

FOR FREIGHT FORWARDING (U.S. CLS. 100 AND 105).

FRANK LATTUCA, EXAMINING ATTORNEY

CLASS 39—(Continued).

SN 85-110,316. FILE GOFER, LLC, TRAVERSE CITY, MI. FILED 8-18-2010.



THE MARK CONSISTS OF WORDING AND DESIGNS WITHIN AN IRREGULAR RECTANGULAR BORDER. ON THE LEFT SIDE OF THE MARK, THERE IS A STYLIZED DESIGN OF A GOPHER EMERGING FROM A HOLE HOLDING A FILE FOLDER. TO THE RIGHT OF THE DESIGN THE WORDING "FILEGOFER" APPEARS.

FOR ELECTRONIC DOCUMENT ARCHIVING SERVICES; STORAGE SERVICES FOR ARCHIVING ELECTRONIC DATA (U.S. CLS. 100 AND 105).

FIRST USE 5-20-2009; IN COMMERCE 5-20-2009.

CORY BOONE, EXAMINING ATTORNEY

SN 85-124,388. FLAT RATE MOVERS, LTD., DBA FLA-TRATE MOVING, BRONX, NY. FILED 9-7-2010.

FlatRate Moving

THE MARK CONSISTS OF STANDARD CHARACTERS WITHOUT CLAIM TO ANY PARTICULAR FONT, STYLE, SIZE, OR COLOR.

OWNER OF U.S. REG. NOS. 2,910,322, 3,987,062 AND OTHERS.

NO CLAIM IS MADE TO THE EXCLUSIVE RIGHT TO USE "MOVING", APART FROM THE MARK AS SHOWN.

SEC. 2(F).

FOR FURNITURE MOVING; FURNITURE STORAGE; MOVING COMPANY SERVICES (U.S. CLS. 100 AND 105).

FIRST USE 10-21-1991; IN COMMERCE 1-22-2001.

CHRISTINA SOBRAL, EXAMINING ATTORNEY

SN 85-125,911. JOHNSON UTILITIES, LLC, SCOTTSDALE, AZ. FILED 9-9-2010.

JOHNSON UTILITIES

THE MARK CONSISTS OF STANDARD CHARACTERS WITHOUT CLAIM TO ANY PARTICULAR FONT, STYLE, SIZE, OR COLOR.

NO CLAIM IS MADE TO THE EXCLUSIVE RIGHT TO USE "UTILITIES", APART FROM THE MARK AS SHOWN.

SEC. 2(F).

FOR PUBLIC UTILITY SERVICES (U.S. CLS. 100 AND 105).

FIRST USE 8-1-1998; IN COMMERCE 8-1-1998.

DOMINICK J. SALEMI, EXAMINING ATTORNEY

CLASS 39—(Continued).

SN 85-139,124. BREWSTER INC., BANFF, ALBERTA, CANADA, FILED 9-27-2010.

**BREWSTER BANFF AIRPORT
EXPRESS**

THE MARK CONSISTS OF STANDARD CHARACTERS WITHOUT CLAIM TO ANY PARTICULAR FONT, STYLE, SIZE, OR COLOR.

PRIORITY CLAIMED UNDER SEC. 44(D) ON CANADA APPLICATION NO. 1474571, FILED 3-25-2010.

OWNER OF U.S. REG. NOS. 2,726,525 AND 3,688,182.

NO CLAIM IS MADE TO THE EXCLUSIVE RIGHT TO USE "AIRPORT EXPRESS", APART FROM THE MARK AS SHOWN.

FOR AIRPORT PASSENGER SHUTTLE SERVICES BETWEEN THE AIRPORT PARKING FACILITIES AND THE AIRPORT; TRANSPORTATION RESERVATION SERVICES FOR AIRPORT SHUTTLES (U.S. CLS. 100 AND 105).

REBECCA SMITH, EXAMINING ATTORNEY

SN 85-152,224. BREWSTER INC., BANFF, ALBERTA, CANADA, FILED 10-13-2010.

brewster  **transportation**
CONNECT.

OWNER OF U.S. REG. NOS. 2,726,525 AND 3,688,182.

NO CLAIM IS MADE TO THE EXCLUSIVE RIGHT TO USE "TRANSPORTATION", APART FROM THE MARK AS SHOWN.

THE COLOR(S) BLUE, BLACK AND GRAY IS/ARE CLAIMED AS A FEATURE OF THE MARK.

THE MARK CONSISTS OF THE WORD "BREWSTER" IN BLACK WITH WORDS "TRANSPORTATION" IN GRAY; AN ICON WHICH IS A FRAMED, STYLIZED DEPICTION OF A ROAD EXPANDING INTO THE DISTANCE IN THE COLOR BLUE IS BETWEEN WORD "BREWSTER" AND WORD "TRANSPORTATION" AND THE WORD "CONNECT" IN BLUE IS RIGHT JUSTIFIED UNDERNEATH THE WORD "TRANSPORTATION".

FOR TRANSPORTATION SERVICES, NAMELY, PROVIDING SHUTTLE SERVICES BY BUS AND VAN; TRAVEL AGENCY SERVICES, NAMELY, MAKING RESERVATIONS AND BOOKINGS FOR TRANSPORTATION; SIGHTSEEING TOURS AND TRAVEL TOURS; CHARTER BUS SERVICES; TOUR GUIDE AND SIGHTSEEING SERVICES (U.S. CLS. 100 AND 105).

REBECCA SMITH, EXAMINING ATTORNEY

CLASS 39—(Continued).

SN 85-189,007. SOUTHWEST PENNSYLVANIA RAILROAD COMPANY, OAKMONT, PA. FILED 12-2-2010.

**Southwest Pennsylvania
Railroad**

THE MARK CONSISTS OF STANDARD CHARACTERS WITHOUT CLAIM TO ANY PARTICULAR FONT, STYLE, SIZE, OR COLOR.

NO CLAIM IS MADE TO THE EXCLUSIVE RIGHT TO USE "RAILROAD", APART FROM THE MARK AS SHOWN. SEC. 2(F).

FOR TRANSPORTATION OF FREIGHT BY RAILROAD (U.S. CLS. 100 AND 105).

FIRST USE 6-24-1995; IN COMMERCE 6-24-1995.

CHRISTINA SOBRAL, EXAMINING ATTORNEY

SN 85-190,660. HDENVIRONMENTS.COM, SEBASTOPOL, CA. FILED 12-3-2010.

NATUREWINDOW

THE MARK CONSISTS OF STANDARD CHARACTERS WITHOUT CLAIM TO ANY PARTICULAR FONT, STYLE, SIZE, OR COLOR.

FOR ENTERTAINMENT SERVICES IN THE NATURE OF NON-DOWNLOADABLE VIDEOS FEATURING HIGH DEFINITION VIDEO IMAGERY ACCOMPANIED BY MUSIC AND NATURAL SOUND IN THE FIELD OF TRAVEL TRANSMITTED VIA THE INTERNET; ENTERTAINMENT SERVICES IN THE NATURE OF NON-DOWNLOADABLE VIDEOS FEATURING HIGH DEFINITION VIDEO IMAGERY ACCOMPANIED BY MUSIC AND NATURAL SOUND IN THE FIELD OF TRAVEL TRANSMITTED VIA A VIDEO-ON-DEMAND SERVICE (U.S. CLS. 100 AND 105).

FIRST USE 11-11-2010; IN COMMERCE 11-12-2010.

KATHERINE CONNOLLY, EXAMINING ATTORNEY

SN 85-208,583. KELTRANS LLC, DBA THE FREIGHT DUDE, NORTH LAS VEGAS, NV. FILED 12-31-2010.

The Freight Dude

NO CLAIM IS MADE TO THE EXCLUSIVE RIGHT TO USE "FREIGHT", APART FROM THE MARK AS SHOWN.

THE COLOR(S) BLACK IS/ARE CLAIMED AS A FEATURE OF THE MARK.

THE MARK CONSISTS OF TEXT GRAPHIC IN BLACK. THE FIRST WORD "THE" IS VERTICAL "FREIGHT DUDE" IS HORIZONTAL.

FOR FREIGHT BROKERAGE INCLUDING TRUCKLOAD, LESS THAN TRUCKLOAD, AIR FREIGHT, PARCEL AND INTERMODAL SERVICES (U.S. CLS. 100 AND 105).

FIRST USE 12-15-2010; IN COMMERCE 12-15-2010.

PRISCILLA MILTON, EXAMINING ATTORNEY

CLASS 39—(Continued).

SN 85-240,109. CLEEVES, FREDERICK GARY, SCOTTS-DALE, AZ. FILED 2-11-2011.



NO CLAIM IS MADE TO THE EXCLUSIVE RIGHT TO USE "HELICOPTERS", APART FROM THE MARK AS SHOWN.

THE MARK CONSISTS OF THE WORDING OF "SKY BLUE HELICOPTERS" ALL IN LOWER CASE. THERE IS A ROTOR GRAPHIC TO THE LEFT.

FOR AIR CHARTER SERVICES; AIR CHARTER TRANSPORTATION SERVICES; AIR TRANSPORT; AIR TRANSPORT SERVICES; AIR TRANSPORTATION; AIR TRANSPORTATION OF PASSENGERS AND FREIGHT (U.S. CLS. 100 AND 105).

FIRST USE 2-3-2011; IN COMMERCE 2-7-2011.
APRIL HESIK, EXAMINING ATTORNEY

SN 85-262,034. RODRIGUEZ-OTERO, DAVID, CIALES, PUERTO RICO, FILED 3-9-2011.

TRIPOLIN

THE MARK CONSISTS OF STANDARD CHARACTERS WITHOUT CLAIM TO ANY PARTICULAR FONT, STYLE, SIZE, OR COLOR.

FOR TRAVEL GUIDE SERVICES PROVIDED ONLINE (U.S. CLS. 100 AND 105).

FIRST USE 8-8-2010; IN COMMERCE 8-8-2010.
CHARLES L. JENKINS, EXAMINING ATTORNEY

SN 85-267,604. COOPER NATURAL RESOURCES, INC., TULSA, OK. FILED 3-15-2011.



OWNER OF U.S. REG. NOS. 3,903,028 AND 3,903,029.
NO CLAIM IS MADE TO THE EXCLUSIVE RIGHT TO USE "NATURAL RESOURCES", APART FROM THE MARK AS SHOWN.

THE MARK CONSISTS OF THE LETTERS "CNR" ABOVE A BANNER CONTAINING THE WORDING "COOPER NATURAL RESOURCES".

FOR DISTRIBUTION SERVICES, NAMELY, DELIVERY OF CHEMICALS (U.S. CLS. 100 AND 105).
FIRST USE 1-1-2007; IN COMMERCE 1-1-2007.
ALICE BENMAMAN, EXAMINING ATTORNEY

CLASS 39—(Continued).

SN 85-269,191. MEDICAL EMBASSY LLC, DELRAY BEACH, FL. FILED 3-17-2011.

MEDICAL EMBASSY

THE MARK CONSISTS OF STANDARD CHARACTERS WITHOUT CLAIM TO ANY PARTICULAR FONT, STYLE, SIZE, OR COLOR.

NO CLAIM IS MADE TO THE EXCLUSIVE RIGHT TO USE "MEDICAL", APART FROM THE MARK AS SHOWN.

FOR MEDICAL TOURISM SERVICES, NAMELY, MAKING TRANSPORTATION RESERVATIONS AND BOOKINGS FOR TRAVEL TO ANOTHER COUNTRY IN ORDER TO OBTAIN HEALTH CARE (U.S. CLS. 100 AND 105).

FIRST USE 8-8-2009; IN COMMERCE 1-5-2010.
FLORENTINA BLANDU, EXAMINING ATTORNEY

SN 85-272,514. THE HEALTH AND HOSPITAL CORPORATION OF MARION COUNTY, AKA WISHARD HEALTH SERVICES, INDIANAPOLIS, IN. FILED 3-21-2011.



NO CLAIM IS MADE TO THE EXCLUSIVE RIGHT TO USE "INDIANAPOLIS EMS", APART FROM THE MARK AS SHOWN.

THE MARK CONSISTS OF A DESIGN CONSISTING OF A CARET SIGN POINTING TO THE RIGHT, SURROUNDED BY SPOKES PROTRUDING FROM THE CARET AT THE TOP, BOTTOM AND RIGHT SIDES. TO THE RIGHT OF THE DESIGN ARE THE WORD "INDIANAPOLIS" AND THE LETTERS "EMS" THE LATTER IS UNDERLINED IN A STYLIZED FORMAT.

FOR AMBULANCE TRANSPORT (U.S. CLS. 100 AND 105).
FIRST USE 12-26-2010; IN COMMERCE 3-9-2011.
FLORENTINA BLANDU, EXAMINING ATTORNEY

CLASS 39—(Continued).

SN 85-273,554. ALASKA AIRLINES, INC., SEATTLE, WA. FILED 3-22-2011.

Alaska Air Cargo

OWNER OF U.S. REG. NOS. 1,462,269, 1,674,552 AND OTHERS.

NO CLAIM IS MADE TO THE EXCLUSIVE RIGHT TO USE "AIR CARGO", APART FROM THE MARK AS SHOWN.

THE MARK CONSISTS OF "ALASKA AIR CARGO" IN FROZEN SCRIPT.

SEC. 2(F).

FOR TRANSPORTATION OF PACKAGES, FREIGHT, AND CARGO BY AIR (U.S. CLS. 100 AND 105).

FIRST USE 11-0-2005; IN COMMERCE 11-0-2005.

HANNO RITTNER, EXAMINING ATTORNEY

CLASS 39—(Continued).

SN 85-274,253. FEDERAL EXPRESS CORPORATION, MEMPHIS, TN. FILED 3-23-2011.

FEDEX SHIP CENTER

THE MARK CONSISTS OF STANDARD CHARACTERS WITHOUT CLAIM TO ANY PARTICULAR FONT, STYLE, SIZE, OR COLOR.

OWNER OF U.S. REG. NOS. 1,311,503, 2,941,184 AND OTHERS.

NO CLAIM IS MADE TO THE EXCLUSIVE RIGHT TO USE "SHIP CENTER", APART FROM THE MARK AS SHOWN.

FOR PICK-UP, TRANSPORTATION, STORAGE AND DELIVERY OF DOCUMENTS, PACKAGES AND FREIGHT BY LAND AND AIR (U.S. CLS. 100 AND 105).

FIRST USE 3-16-2009; IN COMMERCE 3-16-2009.

ELISSA GARBER KÖN, EXAMINING ATTORNEY

SN 85-276,766. VIKING RIVER CRUISES (BERMUDA) LTD., HAMILTON HM 11, BERMUDA, FILED 3-25-2011.

SN 85-274,205. HUNT OF A LIFETIME, INC., DBA HUNT OF A LIFETIME FOUNDATION, INC., HARBORCREEK, PA. FILED 3-23-2011.

Hunt of a Lifetime Foundation

THE MARK CONSISTS OF STANDARD CHARACTERS WITHOUT CLAIM TO ANY PARTICULAR FONT, STYLE, SIZE, OR COLOR.

NO CLAIM IS MADE TO THE EXCLUSIVE RIGHT TO USE "HUNT" AND "FOUNDATION", APART FROM THE MARK AS SHOWN.

FOR ORGANIZATION OF TRIPS (U.S. CLS. 100 AND 105).

FIRST USE 3-21-2001; IN COMMERCE 3-21-2001.

LINDSEY RUBIN, EXAMINING ATTORNEY

VIKING LONGSHIPS

THE MARK CONSISTS OF STANDARD CHARACTERS WITHOUT CLAIM TO ANY PARTICULAR FONT, STYLE, SIZE, OR COLOR.

OWNER OF U.S. REG. NOS. 2,796,425, 3,980,867 AND OTHERS.

FOR TRANSPORT OF PASSENGERS AND OF GOODS; CRUISE SERVICES; CRUISE SHIP SERVICES; TRAVEL AGENCY SERVICES, NAMELY, MAKING RESERVATIONS AND TAKING BOOKINGS FOR TRANSPORTATION OF PASSENGERS AND GOODS; TOUR OPERATING SERVICES; ARRANGING OF CRUISES; RESERVATION SERVICES FOR TRANSPORTATION; CRUISE AND CRUISE SHIP RESERVATION SERVICES; ORGANIZATION OF EXCURSIONS; PROVISION OF INFORMATION AND ADVICE RELATING TO ALL THE AFORESAID SERVICES (U.S. CLS. 100 AND 105).

JOHN GARTNER, EXAMINING ATTORNEY

CLASS 39—(Continued).

SN 85-277,032. REINAUER TRANSPORTATION COMPANIES, LLC, STATEN ISLAND, NY. FILED 3-25-2011.



THE COLOR(S) "RED" IS/ARE CLAIMED AS A FEATURE OF THE MARK.

THE MARK CONSISTS OF THE LETTER "R" INSIDE A DIAMOND-SHAPED BOX ON A SWALLOWTAIL FLAG, ALL IN RED WITH THE BLACK AS SHADOWING ONLY AND IS NOT PART OF THE MARK.

FOR TUGBOAT SERVICES; MARINE TRANSPORTATION; BARGE SHIP ASSIST SERVICES, NAMELY, MARINE TOWING OF BARGES AND SHIPS; SHIP RESCUE SERVICES; VESSEL LINE HANDING SERVICES, NAMELY, ASSISTING IN THE MOORING AND UNMOORING OF BARGES; NAVAL SHIPYARD SERVICES; TRANSPORTATION, SHIPPING AND DELIVERY OF PETROLEUM PRODUCTS AND/OR BIOFUELS; CONSULTATION SERVICES IN THE FIELD OF TRANSPORTATION, SHIPPING AND DELIVERY OF PETROLEUM PRODUCTS AND/OR BIOFUELS (U.S. CLS. 100 AND 105).

FIRST USE 0-0-1923; IN COMMERCE 0-0-1923.
SCOTT BIBB, EXAMINING ATTORNEY

SN 85-277,036. REINAUER TRANSPORTATION COMPANIES, LLC, STATEN ISLAND, NY. FILED 3-25-2011.



THE COLOR(S) RED IS/ARE CLAIMED AS A FEATURE OF THE MARK.

THE MARK CONSISTS OF THE LETTER "R" INSIDE A DIAMOND-SHAPED BOX, ALL IN RED.

FOR TUGBOAT SERVICES; MARINE TRANSPORTATION; BARGE SHIP ASSIST SERVICES, NAMELY, MARINE TOWING OF BARGES AND SHIPS; SHIP RESCUE SERVICES; VESSEL LINE HANDING SERVICES, NAMELY, ASSISTING IN THE MOORING AND UNMOORING OF BARGES; NAVAL SHIPYARD SERVICES; TRANSPORTATION, SHIPPING AND DELIVERY OF PETROLEUM PRODUCTS AND/OR BIOFUELS; CONSULTATION SERVICES IN THE FIELD OF TRANSPORTATION, SHIPPING AND DELIVERY OF PETROLEUM PRODUCTS AND/OR BIOFUELS (U.S. CLS. 100 AND 105).

FIRST USE 0-0-1923; IN COMMERCE 0-0-1923.
SCOTT BIBB, EXAMINING ATTORNEY

CLASS 39—(Continued).

SN 85-283,574. GLOBAL CUSTOM COMMERCE L.P., HOUSTON, TX. FILED 4-1-2011.

SUREFIT

THE MARK CONSISTS OF STANDARD CHARACTERS WITHOUT CLAIM TO ANY PARTICULAR FONT, STYLE, SIZE, OR COLOR.

FOR SHIPPING AND DELIVERY SERVICE TO EXCHANGE OR REPLACE MIS-MEASURED WINDOW COVERING PRODUCTS SUCH AS BLINDS AND SHADES VIA VARIOUS MODES OF TRANSPORTATION (U.S. CLS. 100 AND 105).

FIRST USE 3-31-2011; IN COMMERCE 3-31-2011.
LINDSEY RUBIN, EXAMINING ATTORNEY

SN 85-289,328. FEDERAL EXPRESS CORPORATION, MEMPHIS, TN. FILED 4-7-2011.

FedEx Custom Critical SecureComm

THE MARK CONSISTS OF STANDARD CHARACTERS WITHOUT CLAIM TO ANY PARTICULAR FONT, STYLE, SIZE, OR COLOR.

OWNER OF U.S. REG. NOS. 3,125,953, 3,764,608 AND OTHERS.

FOR PICK-UP, TRANSPORTATION, STORAGE AND DELIVERY OF DOCUMENTS, PACKAGES AND FREIGHT BY LAND AND AIR (U.S. CLS. 100 AND 105).
ELISSA GARBER KON, EXAMINING ATTORNEY

SN 85-290,254. FEDERAL EXPRESS CORPORATION, MEMPHIS, TN. FILED 4-8-2011.

FEDEX INTERNATIONAL MAIL VIEW

THE MARK CONSISTS OF STANDARD CHARACTERS WITHOUT CLAIM TO ANY PARTICULAR FONT, STYLE, SIZE, OR COLOR.

OWNER OF U.S. REG. NOS. 2,067,624, 2,912,878 AND OTHERS.

NO CLAIM IS MADE TO THE EXCLUSIVE RIGHT TO USE "INTERNATIONAL MAIL", APART FROM THE MARK AS SHOWN.

FOR CARGO SERVICES, NAMELY, PICK UP, TRANSPORTATION AND DELIVERY OF DOCUMENTS AND PACKAGES BY TRUCK AND PLANE (U.S. CLS. 100 AND 105).

ELISSA GARBER KON, EXAMINING ATTORNEY

CLASS 39—(Continued).

SN 85-293,031. J&O CORPORATION, MEDINA, OH. FILED 4-12-2011.

JunkAway

THE MARK CONSISTS OF STANDARD CHARACTERS WITHOUT CLAIM TO ANY PARTICULAR FONT, STYLE, SIZE, OR COLOR.

FOR CARTAGE SERVICES, NAMELY TRANSPORTING MATERIAL BY TRUCK FOR OTHERS IN AN ENVIRONMENTALLY-FRIENDLY WAY (U.S. CLS. 100 AND 105).

FIRST USE 9-2-2010; IN COMMERCE 9-2-2010.
KAREN BRACEY, EXAMINING ATTORNEY

SN 85-294,658. HAYNIE, ASHLEY, CANBY, OR. FILED 4-13-2011.

Coffee Fairy

THE MARK CONSISTS OF STANDARD CHARACTERS WITHOUT CLAIM TO ANY PARTICULAR FONT, STYLE, SIZE, OR COLOR.

NO CLAIM IS MADE TO THE EXCLUSIVE RIGHT TO USE "COFFEE", APART FROM THE MARK AS SHOWN.

FOR DELIVERY OF DRINKS, INCLUDING SPECIALTY COFFEE DRINKS, AND FOOD TO INDIVIDUALS AND BUSINESSES (U.S. CLS. 100 AND 105).

FIRST USE 10-27-2010; IN COMMERCE 10-27-2010.
KATHERINE CHANG, EXAMINING ATTORNEY

CLASS 39—(Continued).

SN 85-294,688. HAYNIE, ASHLEY, CANBY, OR. FILED 4-13-2011.



NO CLAIM IS MADE TO THE EXCLUSIVE RIGHT TO USE "COFFEE", APART FROM THE MARK AS SHOWN.

THE MARK CONSISTS OF TWO SYMMETRICAL FAIRY WINGS, WITH WHITE WING FEATHERS OUTLINED IN BLACK, AND THE WORDS "COFFEE FAIRY" WRITTEN OVER THE WINGS. THE FIRST "F" IN THE WORD "COFFEE" IS ALSO USED AS THE "F" IN "FAIRY". THE BLACK SQUARE IS INTENDED TO REPRESENT THE BACKGROUND AND IS NOT CLAIMED AS A FEATURE OF THE MARK.

FOR DELIVERY OF DRINKS, INCLUDING SPECIALTY COFFEE DRINKS, AND FOOD TO INDIVIDUALS AND BUSINESSES (U.S. CLS. 100 AND 105).

FIRST USE 10-27-2010; IN COMMERCE 10-27-2010.
KATHERINE CHANG, EXAMINING ATTORNEY

SN 85-294,727. CHOSID, RICHARD G., LIGHTHOUSE POINT, FL. AND COURANT, SCOTT, BOCA RATON, FL. FILED 4-13-2011.

BALLET PARKING

THE MARK CONSISTS OF STANDARD CHARACTERS WITHOUT CLAIM TO ANY PARTICULAR FONT, STYLE, SIZE, OR COLOR.

NO CLAIM IS MADE TO THE EXCLUSIVE RIGHT TO USE "PARKING", APART FROM THE MARK AS SHOWN.

FOR VALET PARKING (U.S. CLS. 100 AND 105).
DAWN FELDMAN, EXAMINING ATTORNEY

CLASS 40—MATERIAL TREATMENT

SN 79-093,690. TRISOPLAST INTERNATIONAL B.V., NETHERLANDS, FILED 9-9-2010.

MULTRIWELL

THE MARK CONSISTS OF STANDARD CHARACTERS WITHOUT CLAIM TO ANY PARTICULAR FONT, STYLE, SIZE, OR COLOR.

PRIORITY DATE OF 4-13-2010 IS CLAIMED.
OWNER OF INTERNATIONAL REGISTRATION 1067414 DATED 9-9-2010, EXPIRES 9-9-2020.

THE WORDING "MULTRIWELL" HAS NO MEANING IN A FOREIGN LANGUAGE.

FOR GAS PROCESSING OF WASTE PRODUCTS, NAMELY, THE EXTRACTION OF GASSES ON DUMPING SITES; ADVISORY SERVICES IN THE FIELD OF THE EXTRACTION OF GASSES ON DUMPING SITES (U.S. CLS. 100, 103 AND 106).

KAPIL BHANOT, EXAMINING ATTORNEY

SN 85-182,710. T.S.E. CERTIFICATION, LLC, AVENTURA, FL. FILED 11-22-2010.

T.S.E. CERT.

THE MARK CONSISTS OF STANDARD CHARACTERS WITHOUT CLAIM TO ANY PARTICULAR FONT, STYLE, SIZE, OR COLOR.

FOR CONTRACT MANUFACTURING IN THE FIELD OF WATCHES (U.S. CLS. 100, 103 AND 106).

DAVID I, EXAMINING ATTORNEY

SN 85-202,444. MEDTECH HOLDINGS, INC., SOUTH PLAINFIELD, NJ. FILED 12-21-2010.

VENTION MEDICAL

THE MARK CONSISTS OF STANDARD CHARACTERS WITHOUT CLAIM TO ANY PARTICULAR FONT, STYLE, SIZE, OR COLOR.

NO CLAIM IS MADE TO THE EXCLUSIVE RIGHT TO USE "MEDICAL", APART FROM THE MARK AS SHOWN.

FOR ASSEMBLY OF PRODUCTS FOR OTHERS; CUSTOM MANUFACTURE OF MEDICAL DEVICES AND MEDICAL DEVICE COMPONENTS; CONTRACT MANUFACTURING IN THE FIELD OF MEDICAL DEVICES (U.S. CLS. 100, 103 AND 106).

SKYE YOUNG, EXAMINING ATTORNEY

CLASS 40—(Continued).

SN 85-204,290. EMILIA PERSONAL CARE INC., DUBLIN, OH. FILED 12-22-2010.

EMILIA

THE MARK CONSISTS OF STANDARD CHARACTERS WITHOUT CLAIM TO ANY PARTICULAR FONT, STYLE, SIZE, OR COLOR.

FOR CUSTOM MANUFACTURE OF NON-MEDICATED SKIN CARE PREPARATIONS, FACIAL CLEANSERS, NON-MEDICATED ACNE PREPARATIONS, HAIR CARE PREPARATIONS, DEODORANTS AND ANTIPERSPIRANTS, BODY SPRAYS, BODY WASH, SHOWER GEL, BODY LOTIONS, BODY FRAGRANCE MIST AND SPLASH, ANTI-BACTERIAL HAND SOAP, ANTI-BACTERIAL WATERLESS SANITIZERS, BAR SOAP, BODY BUTTERS, BODY CREAMS, BODY SCRUBS, BUBBLE BATH, NON-MEDICATED BODY SOAKS, EAU DE TOILETTE, FACIAL MOISTURIZERS, FACIAL ANTI-AGING, BODY LOTIONS, FADE BLEACH FOR THE SKIN, DEPILATORIES, SPF AND NON SPF SUN BLOCK PREPARATIONS AND TOWELETTES, LIQUID SOAP, BATH LOTIONS, BATH SALTS, TOWELETTES FOR FACE AND BODY, HAIR SHAMPOOS, HAIR CONDITIONERS, HAIR OILS, HAIR GELS, HAIR MOUSSE, HAIR SPRAY, MEDICATED SKIN CARE PREPARATIONS, MEDICATED HAIR CARE PREPARATIONS, MEDICATED BODY SOAKS AND MEDICATED ACNE PREPARATIONS FOR PRIVATE LABEL BRANDS (U.S. CLS. 100, 103 AND 106).

MARY BOAGNI, EXAMINING ATTORNEY

SN 85-208,901. HICKS, MAURICE, GREENSBORO, NC. FILED 1-2-2011.



THE MARK CONSISTS OF A STICK FIGURE IMAGE WITH ARMS AND LEGS SPREAD OUT, ON A SKATEBOARD WEARING A SKI-TYPE HAT ON ITS HEAD.

FOR IMPRINTING MESSAGES ON WEARING APPAREL, ACCESSORIES AND MUGS (U.S. CLS. 100, 103 AND 106).

JANICE KIM, EXAMINING ATTORNEY

CLASS 40—(Continued).

SN 85-226,425. THE HUNTON GROUP, HOUSTON, TX.
FILED 1-26-2011.



NO CLAIM IS MADE TO THE EXCLUSIVE RIGHT TO USE "CONVERGENCE", APART FROM THE MARK AS SHOWN.

THE COLOR(S) BLACK, DARK GREEN, GREEN, AND LIGHT GREEN IS/ARE CLAIMED AS A FEATURE OF THE MARK.

THE MARK CONSISTS OF THE STYLIZED WORDING "CONVERGENTZ" IN THE COLOR BLACK, EXCEPT FOR THE LETTER "V", WHICH IS COMPRISED OF A GENERALLY TRIANGULAR SHAPE FORMED BY THREE SETS OF DIAGONAL BANDS, WHERE THE OUTERMOST BAND IS IN THE COLOR DARK GREEN, THE INNERMOST BAND IS IN THE COLOR LIGHT GREEN, AND THE MIDDLE BAND IS IN THE COLOR GREEN. BELOW THE STYLIZED WORDING "CONVERGENTZ" IS THE STYLIZED WORDING "MAKING BUILDINGS SMARTER" IN THE COLOR BLACK.

FOR CUSTOM CONSTRUCTION OF NON-STRUCTURAL AUTOMATED SYSTEMS FOR BUILDINGS IN THE NATURE OF AUTOMATED ENERGY MANAGEMENT SYSTEMS, AUTOMATED LIGHTING, AUTOMATED HVAC SYSTEMS, ALARM SYSTEMS, SURVEILLANCE AND ACCESS CONTROL SYSTEMS, INTERNET AND VIDEOCONFERENCING SYSTEMS, INTERACTIVE MEDIA HARDWARE SYSTEMS, AUTOMATED DIGITAL SIGNAGE AND AUTOMATED CONTROLS FOR SYSTEMS MANAGEMENT (U.S. CLS. 100, 103 AND 106).

FIRST USE 1-24-2011; IN COMMERCE 1-24-2011.
JAY BESCH, EXAMINING ATTORNEY

SN 85-254,940. DUNNE, PATRICK, LOS ANGELES, CA.
FILED 3-1-2011.

Silverprofile

THE MARK CONSISTS OF STANDARD CHARACTERS WITHOUT CLAIM TO ANY PARTICULAR FONT, STYLE, SIZE, OR COLOR.

FOR CUSTOM MANUFACTURE OF SILVER JEWELRY TO THE ORDER AND SPECIFICATION OF OTHERS (U.S. CLS. 100, 103 AND 106).

FIRST USE 1-31-2011; IN COMMERCE 1-31-2011.
MICHELLE DUBOIS, EXAMINING ATTORNEY

CLASS 40—(Continued).

SN 85-266,693. HOVER, ERIK, RANCHO CUCAMONGA, CA.
FILED 3-14-2011.



NO CLAIM IS MADE TO THE EXCLUSIVE RIGHT TO USE "APPAREL GROUP", APART FROM THE MARK AS SHOWN.

THE STIPPLING IS FOR SHADING PURPOSES ONLY.

THE MARK CONSISTS OF 7 VERTICAL RECTANGLES, EVENLY SPACED, ASCENDING IN HEIGHT AND OPACITY FROM LEFT TO RIGHT. TO THE RIGHT THERE IS THE STYLIZED TEXT "THE SUBURBAN APPAREL GROUP".

FOR EMBROIDERY SERVICES; SCREEN PRINTING; SILK SCREEN PRINTING (U.S. CLS. 100, 103 AND 106).
FIRST USE 9-1-2007; IN COMMERCE 1-1-2010.

LAURIE KAUFMAN, EXAMINING ATTORNEY

SN 85-268,373. METROTILE MANUFACTURING, DBA METRO ROOF PRODUCTS, OCEANSIDE, CA. FILED 3-16-2011.

METROTILE

THE MARK CONSISTS OF STANDARD CHARACTERS WITHOUT CLAIM TO ANY PARTICULAR FONT, STYLE, SIZE, OR COLOR.

OWNER OF U.S. REG. NOS. 2,548,950, 3,170,626 AND OTHERS.

FOR MANUFACTURING SERVICES FOR OTHERS IN THE FIELD OF METAL ROOFING AND ROOFING COMPONENTS, NAMELY, ROOF HIPS AND RIDGE PIECES, VALLEY PIECES, ROOF AND FASCIA FLASHING AND TRIMS, AND TRANSPORTABLE METAL BUILDINGS (U.S. CLS. 100, 103 AND 106).

FIRST USE 3-12-1999; IN COMMERCE 3-12-1999.
BRIAN PINO, EXAMINING ATTORNEY

CLASS 40—(Continued).

SN 85-268,934. THE REGISTER PRINT GROUP, INC., CLIFTON, NJ. FILED 3-16-2011.



NO CLAIM IS MADE TO THE EXCLUSIVE RIGHT TO USE "PRINT GROUP", APART FROM THE MARK AS SHOWN.

THE COLOR(S) BLACK, YELLOW, MAGENTA, BLUE IS/ ARE CLAIMED AS A FEATURE OF THE MARK.

THE MARK CONSISTS OF THE WORD "THE" CENTERED ABOVE "REGISTER" CENTERED ABOVE THE WORDS "PRINT GROUP", ALL IN BLACK UPPERCASE STYLIZED FONT. ABOVE THE DESCRIBED WORDS IS A SQUARE MADE OF FOUR SMALLER SQUARES, ONE COLORED BLACK, ONE YELLOW, ONE MAGENTA AND ONE BLUE.

FOR PRINTING SERVICES (U.S. CLS. 100, 103 AND 106).

FIRST USE 2-0-2009; IN COMMERCE 2-0-2009. FLORENTINA BLANDU, EXAMINING ATTORNEY

SN 85-275,563. SYNGENTA PARTICIPATIONS AG, BASEL, SWITZERLAND, FILED 3-24-2011.

Farmore

THE MARK CONSISTS OF STANDARD CHARACTERS WITHOUT CLAIM TO ANY PARTICULAR FONT, STYLE, SIZE, OR COLOR.

FOR AGRICULTURAL SERVICES, NAMELY, SEED TREATMENT SERVICES FOR OTHERS (U.S. CLS. 100, 103 AND 106).

WILLIAM ROSSMAN, EXAMINING ATTORNEY

CLASS 40—(Continued).

SN 85-277,182. ARCADIS N.V., AMSTERDAM, NETHERLANDS, FILED 3-25-2011.



OWNER OF U.S. REG. NOS. 2,236,634, 3,662,374 AND OTHERS.

NO CLAIM IS MADE TO THE EXCLUSIVE RIGHT TO USE "INFRASTRUCTURE WATER ENVIRONMENT BUILDINGS", APART FROM THE MARK AS SHOWN.

THE NAME "MALCOLM PIRNIE" DOES NOT IDENTIFY A LIVING INDIVIDUAL.

THE MARK CONSISTS OF A STYLIZED REPRESENTATION OF A SALAMANDER FOLLOWED BY THE WORD "ARCADIS" THAT IS ADJACENT TO THE PHRASE "MALCOLM PIRNIE" FRAMED IN A RECTANGULAR BOX; ALL OF WHICH SITS ATOP THE PHRASE "INFRASTRUCTURE WATER ENVIRONMENT BUILDINGS" IN WHICH THE WORDS ARE SEPARATED FROM EACH OTHER BY DOTS.

FOR ENVIRONMENTAL REMEDIATION SERVICES, NAMELY, SOIL, WASTE, WATER AND SEDIMENT TREATMENT SERVICES (U.S. CLS. 100, 103 AND 106).

FIRST USE 1-1-2011; IN COMMERCE 3-15-2011. JAMES LOVELACE, EXAMINING ATTORNEY

SN 85-286,265. COVANTA ENERGY CORPORATION, MORRISTOWN, NJ. FILED 4-5-2011.

REF FUEL

THE MARK CONSISTS OF STANDARD CHARACTERS WITHOUT CLAIM TO ANY PARTICULAR FONT, STYLE, SIZE, OR COLOR.

OWNER OF U.S. REG. NO. 1,602,911.

NO CLAIM IS MADE TO THE EXCLUSIVE RIGHT TO USE "FUEL", APART FROM THE MARK AS SHOWN.

FOR WASTE-TO-FUEL GENERATION SERVICES; WASTE-TO-ENERGY GENERATION SERVICES (U.S. CLS. 100, 103 AND 106).

REBECCA SMITH, EXAMINING ATTORNEY

SN 85-288,788. FUTURAMIK INDUSTRIES, INC., HARTFORD, CT. FILED 4-7-2011.

FUTURAMIK GROUP

THE MARK CONSISTS OF STANDARD CHARACTERS WITHOUT CLAIM TO ANY PARTICULAR FONT, STYLE, SIZE, OR COLOR.

NO CLAIM IS MADE TO THE EXCLUSIVE RIGHT TO USE "GROUP", APART FROM THE MARK AS SHOWN.

FOR PROCESSING OF PLASTICS FOR OTHERS (U.S. CLS. 100, 103 AND 106).

FIRST USE 9-30-2010; IN COMMERCE 9-30-2010. KRISTINA MORRIS, EXAMINING ATTORNEY

CLASS 40—(Continued).

SN 85-290,704. LAY, ISAAC C., BREA, CA. FILED 4-8-2011.

PostalPix

THE MARK CONSISTS OF STANDARD CHARACTERS WITHOUT CLAIM TO ANY PARTICULAR FONT, STYLE, SIZE, OR COLOR.

FOR DIGITAL PHOTO PRINTING SERVICES (U.S. CLS. 100, 103 AND 106).

FIRST USE 7-27-2010; IN COMMERCE 12-17-2010.
MICHELLE DUBOIS, EXAMINING ATTORNEY

SN 85-291,401. GLENARY FLYING FISH, INC., MECHANICSBURG, PA. FILED 4-11-2011.

ARTCO

THE MARK CONSISTS OF STANDARD CHARACTERS WITHOUT CLAIM TO ANY PARTICULAR FONT, STYLE, SIZE, OR COLOR.

FOR MANUFACTURING SERVICES FOR OTHERS IN THE FIELD OF PRODUCING APPAREL BRANDING IDENTIFICATION MATERIALS, NAMELY, PRINTED TEXTILE LABELS, EMBROIDERED TEXTILE LABELS, PRINTED TEXTILE TAGS, EMBROIDERED TEXTILE TAGS, PRINTED PAPER RIBBONS, PRINTED PAPER TAPES/BANDS TO HOLD CLOTHING, EMBOSSED METAL MEDALLIONS, PRINTED CARDBOARD BOXES AS PACKAGING FOR APPAREL, PRINTED POLYESTER BAGS, PRINTED VINYL BAGS, PRINTED CANVAS BAGS, EMBROIDERED LEATHER, SYNTHETIC, AND RUBBER/PVC PATCHES, MOLDED PLASTIC CLOTHING HANGERS, PRINTED PAPER AND CARDBOARD ACCESSORY CARDS WHICH ATTACH TO CLOTHING FOR BRANDING IDENTIFICATION, AND STICKERS (U.S. CLS. 100, 103 AND 106).

FIRST USE 12-31-1981; IN COMMERCE 8-14-2001.
DEZMONA MIZELLE, EXAMINING ATTORNEY

SN 85-293,482. AFFINITY CLOUD MARKETING, LLC, LOS ANGELES, CA. FILED 4-12-2011.

TOUCH TEACH CONNECT

THE MARK CONSISTS OF STANDARD CHARACTERS WITHOUT CLAIM TO ANY PARTICULAR FONT, STYLE, SIZE, OR COLOR.

FOR CUSTOM MANUFACTURE FOR OTHERS OF THREE-DIMENSIONAL CUBES AND OTHER SHAPES THAT UNFOLD TO REVEAL CUSTOMIZED GRAPHICS AND DESIGNS, USED FOR ADVERTISING GOODS AND SERVICES AND FOR EDUCATIONAL PURPOSES (U.S. CLS. 100, 103 AND 106).

FIRST USE 3-10-2011; IN COMMERCE 3-10-2011.
MARK SPARACINO, EXAMINING ATTORNEY

CLASS 40—(Continued).

SN 85-293,760. ECLECTIC CONTRACT FURNITURE INDUSTRIES, INC., NEW YORK, NY. FILED 4-13-2011.

ECLECTIC

THE MARK CONSISTS OF STANDARD CHARACTERS WITHOUT CLAIM TO ANY PARTICULAR FONT, STYLE, SIZE, OR COLOR.

FOR MANUFACTURE OF FURNITURE TO THE ORDER OR TO THE SPECIFICATION OF OTHERS, CONSISTING OF CHAIRS, TABLES, ARMOIRES, NIGHT STANDS, AND HEADBOARDS DESIGNED TO SHOW VIRTUOSO CRAFTSMANSHIP AND FOR THE HOSPITALITY AND RESIDENTIAL MARKETS ONLY (U.S. CLS. 100, 103 AND 106).

FIRST USE 6-0-1996; IN COMMERCE 6-0-1996.
ALLISON HOLTZ, EXAMINING ATTORNEY

SN 85-294,652. CASHMAN PHOTO ENTERPRISES OF NEVADA, LAS VEGAS, NV. FILED 4-13-2011.

IMAGES THAT CLICK

THE MARK CONSISTS OF STANDARD CHARACTERS WITHOUT CLAIM TO ANY PARTICULAR FONT, STYLE, SIZE, OR COLOR.

FOR ALTERATION AND RETOUCHING OF PHOTOGRAPHIC IMAGES; ENHANCEMENT OF PHOTOGRAPHS; FILM DEVELOPMENT AND REPRODUCTION OF PHOTOGRAPHS; PHOTOGRAPH DEVELOPING; RESTORATION OF PHOTOGRAPHS (U.S. CLS. 100, 103 AND 106).

FIRST USE 4-30-2004; IN COMMERCE 4-30-2004.
KATHERINE CHANG, EXAMINING ATTORNEY

SN 85-295,539. GLOCON, INC., PARSIPPANY, NJ. FILED 4-14-2011.

GLOCON

THE MARK CONSISTS OF THE WORD "GLOCON" IN STYLIZED FONT. THE FIRST LETTER "O" IN "GLOCON" IS FORMED BY A DRAWING OF A SPHERE MADE FROM PARALLEL DIAGONAL LINES.

FOR CUSTOM MANUFACTURE OF INDUSTRIAL FANS AND BLOWERS, FIBERGLASS MOLDINGS AND INDUSTRIAL METAL PARTS (U.S. CLS. 100, 103 AND 106).

FIRST USE 6-6-1995; IN COMMERCE 6-6-1995.
LINDA E. BLOHM, EXAMINING ATTORNEY

CLASS 40—(Continued).

SN 85-321,740. JOHNSON, ARRON, SONOMA, CA. FILED 5-16-2011.



NO CLAIM IS MADE TO THE EXCLUSIVE RIGHT TO USE "V-TWIN", APART FROM THE MARK AS SHOWN.

THE MARK CONSISTS OF AN IMAGE OF A COMMON AMERICAN MADE V-TWIN MOTORCYCLE ENGINE, SHOWING THE UPPER CYLINDERS AND HEADS WITH A CARBURETOR IN THE MIDDLE WITH SMALL LETTERS ON IT SAYING "BAD ASS V-TWIN". ALONG SIDE EACH CYLINDER, FACING TO THE FRONT AND REAR ARE SIDE VIEWS OF SKULLS, ONE FACING LEFT, THE OTHER FACING RIGHT. GOING ACROSS THE LOWER SIDE OF THE V TWIN ENGINE IMAGE IS A FLAMED BANNER WITH LARGER WORDS "BAD ASS" INSIDE IT WITH THE FLAME TIPS INTERTWINING OUT FROM BEHIND THE IMAGE. BELOW THE BANNER IMAGE, BUT STILL ATTACHED, IS A TATTERED LOOKING HUMAN SKULL WITH FEATHERED WINGS STRETCHING OUTWARD FROM THE TEMPLE AREA OF THE SKULL THAT GO BEHIND THE FLAMED BANNER CONTAINING THE LARGE "BAD ASS" WORDS. BEHIND THE ENTIRE IMAGE ARE CLASSIC LOOKING FLAMES THAT STRETCH-OUT FROM THE SIDES AND ABOVE THE V TWIN ENGINE AND CYLINDERS. UNDERNEATH THE IMAGE AND SEPARATED FROM THE IMAGE ARE THE WORDS "V-TWIN".

FOR CUSTOM BUILDING OF MOTORCYCLES (U.S. CLS. 100, 103 AND 106).

SANDRA BUJA, EXAMINING ATTORNEY

CLASS 41—EDUCATION AND ENTERTAINMENT

SN 76-701,055. ABA TRAINING CENTER, LLC, HONOLULU, HI. FILED 12-31-2009.



NO CLAIM IS MADE TO THE EXCLUSIVE RIGHT TO USE "ABA TRAINING CENTER.COM", APART FROM THE MARK AS SHOWN.

THE MARK CONSISTS OF A DESIGN OF FOUR (4) RINGS WHERE TWO (2) ARE STACKED HORIZONTALLY INSIDE OF THE OTHER TWO (2) RINGS, WHICH ARE VERTICAL. THE DESIGN IS TO THE LEFT OF THE WORDING "ABA", WHICH IS OVER THE WORDING "TRAINING CENTER.COM".

FOR APPLICATION OF DERIVED PRINCIPLES OF BEHAVIOR TO IMPROVE SOCIALLY SIGNIFICANT BEHAVIOR, NAMELY, TRAINING SERVICES IN THE FIELD OF APPLYING VARIOUS BEHAVIOR PRINCIPLES TO IMPROVE SOCIAL BEHAVIOR (U.S. CLS. 100, 101 AND 107).

FIRST USE 5-8-2008; IN COMMERCE 5-8-2008.

MAUREEN DALL, EXAMINING ATTORNEY

SN 76-702,377. RECYCLED FISH, COUNCIL BLUFFS, IA. FILED 4-5-2010.



THE LITERAL ELEMENT OF THE MARK CONSISTS OF "RECYCLED FISH". THE MARK CONSISTS OF THE WORDING "RECYCLED FISH" IN STYLIZED LETTERING. THE WORD "RECYCLED" APPEARS PARTIALLY SUPERIMPOSING AN OUTLINE OF A FISH DESIGN. TWO CURVED OPPOSING ARROWS APPEAR AROUND THE FISH. AN OUTLINE APPEARS IN THE ARROWS.

FOR NON-PROFIT ENVIRONMENTAL EDUCATION, NAMELY, ONLINE CLASSES AND SEMINARS FOR OUTDOOR ENTHUSIASTS IN THE FIELD OF STEWARDSHIP OF NATURAL RESOURCES (U.S. CLS. 100, 101 AND 107).

FIRST USE 6-13-2007; IN COMMERCE 5-1-2009.

DANIEL CAPSHAW, EXAMINING ATTORNEY

CLASS 41—(Continued).

SN 76-704,377. LATERAL COMMUNICATIONS, WALNUT CREEK, CA. FILED 9-7-2010.



THE MARK IS CIRCULAR AND OF AN OUTER DARK BAND AROUND A SHADED HEMISPHERE WITH AN INTERMEDIATE SHADED LIGHTER BAND HAVING A STYLIZED CHECKMARK OVERLAYING THE CENTRAL HEMISPHERE. THE OUTER BAND HAS A STYLIZED WORD "LINGO" AT THE TOP AND A CONVENTIONAL CAPITALIZED "VISION" AT THE BOTTOM. COLOR IS NOT CLAIMED AS A FEATURE OF THE MARK.

FOR CONDUCTING CLASSES IN THE FIELD OF LANGUAGE EDUCATION WITH MEDIA, EXERCISES AND SERVICES, NAMELY, GAMES AND INSTRUCTIONAL SESSIONS FOR LEARNING ENGLISH PROVIDED OVER THE WORLD WIDE WEB (U.S. CLS. 100, 101 AND 107).

FIRST USE 3-30-2010; IN COMMERCE 3-30-2010.
KATINA MISTER, EXAMINING ATTORNEY

SN 76-705,721. HOUGHTON MIFFLIN HARCOURT PUBLISHING COMPANY, BOSTON, MA. FILED 12-20-2010.

DATA DIRECTOR

THE MARK CONSISTS OF STANDARD CHARACTERS WITHOUT CLAIM TO ANY PARTICULAR FONT, STYLE, SIZE, OR COLOR.

FOR PROVIDING TEMPORARY USE OF ON-LINE NON-DOWNLOADABLE SOFTWARE TO ENABLE THE CREATION, ANALYSIS, AND REPORTING OF TEST RESULTS AND INSTRUCTIONAL DATA FOR USE IN THE FIELDS OF K-12 TEACHING; AND PROVIDING TEMPORARY USE OF ON-LINE NON-DOWNLOADABLE SOFTWARE TO ENABLE TO ADMINISTER TESTS IN THE FIELD OF K-12 EDUCATION (U.S. CLS. 100, 101 AND 107).

FIRST USE 6-0-2002; IN COMMERCE 6-0-2002.
MICHELLE DUBOIS, EXAMINING ATTORNEY

CLASS 41—(Continued).

SN 76-705,722. HOUGHTON MIFFLIN HARCOURT PUBLISHING COMPANY, BOSTON, MA. FILED 12-20-2010.



THE MARK CONSISTS OF A GRAPH IMAGE CONTAINING FOUR RECTANGLES WITHIN A SHADED RECTANGLE. AN ARROW OVERLAPS THE ENTIRE GRAPH IMAGE. THE WORD "DATADIRECTOR" APPEARS TO THE RIGHT OF THE IMAGE.

FOR PROVIDING TEMPORARY USE OF ON-LINE NON-DOWNLOADABLE SOFTWARE TO ENABLE THE CREATION, ANALYSIS, AND REPORTING OF TEST RESULTS AND INSTRUCTIONAL DATA FOR USE IN THE FIELDS OF K-12 TEACHING; AND PROVIDING TEMPORARY USE OF ON-LINE NON-DOWNLOADABLE SOFTWARE TO ENABLE TO ADMINISTER TESTS IN THE FIELD OF K-12 EDUCATION (U.S. CLS. 100, 101 AND 107).

FIRST USE 6-0-2002; IN COMMERCE 6-0-2002.
MICHELLE DUBOIS, EXAMINING ATTORNEY

SN 76-706,415. BURMESE CLASSIC, INC., AUSTIN, TX. FILED 2-15-2011.

BURMESE CLASSIC

THE MARK CONSISTS OF STANDARD CHARACTERS WITHOUT CLAIM TO ANY PARTICULAR FONT, STYLE, SIZE, OR COLOR.

NO CLAIM IS MADE TO THE EXCLUSIVE RIGHT TO USE "BURMESE", APART FROM THE MARK AS SHOWN.

FOR ENTERTAINMENT SERVICES, NAMELY, PROVIDING A WEBSITE FEATURING ONLINE PUBLICATION OF ARTICLES ABOUT BURMESE CULTURAL ACTIVITIES AND EVENTS (U.S. CLS. 100, 101 AND 107).

FIRST USE 2-13-2006; IN COMMERCE 2-13-2006.
SUSAN LESLIE DUBOIS, EXAMINING ATTORNEY

SN 76-706,592. ROBBINS, EDWARD M., BOCA RATON, FL. FILED 2-28-2011.

EDDIE ROBBINS MELLO KINGS

THE MARK CONSISTS OF STANDARD CHARACTERS WITHOUT CLAIM TO ANY PARTICULAR FONT, STYLE, SIZE, OR COLOR.

THE NAME "EDDIE ROBBINS" IDENTIFIES A LIVING INDIVIDUAL WHOSE CONSENT IS OF RECORD.

FOR ENTERTAINMENT, NAMELY, LIVE MUSIC PERFORMANCE BY A VOCAL GROUP (U.S. CLS. 100, 101 AND 107).

NELSON SNYDER, EXAMINING ATTORNEY

CLASS 41—(Continued).

SN 76-706,593. TIFFANY IV, HENRY D., ESTER, AK. FILED 2-28-2011.



NO CLAIM IS MADE TO THE EXCLUSIVE RIGHT TO USE "ALASKAN", "EXPEDITIONS" AND "HUNT", APART FROM THE MARK AS SHOWN.

THE MARK CONSISTS OF AN ELONGATED RECTANGLE WITH POINTS ON EITHER END AND A HALF CIRCLE ATTACHED ABOVE THIS ELONGATED RECTANGLE. A STYLIZED SNOW-TIPPED MOUNTAIN BEHIND A STYLIZED VALLEY SCENE APPEARS IN THE HALF CIRCLE. THE WORDING "HUNT SMART" APPEARS BELOW THE DESIGN. WITHIN THE ELONGATED RECTANGLE THE WORDING "ALASKAN PERIMETER" APPEARS, AND BENEATH THAT WORDING APPEARS THE WORD "EXPEDITIONS".

FOR HUNTING GUIDE SERVICES; PROVIDING INFORMATION IN THE FIELD OF HUNTING AND FISHING VIA THE INTERNET (U.S. CLS. 100, 101 AND 107).
FIRST USE 1-17-2011; IN COMMERCE 1-17-2011.
NELSON SNYDER, EXAMINING ATTORNEY

CLASS 41—(Continued).

SN 76-706,729. NBCUNIVERSAL MEDIA, LLC, NEW YORK, NY. FILED 3-10-2011.

BE INFORMED. BE ENTERTAINED. BE INSPIRED.

THE MARK CONSISTS OF STANDARD CHARACTERS WITHOUT CLAIM TO ANY PARTICULAR FONT, STYLE, SIZE, OR COLOR.

FOR ENTERTAINMENT SERVICES, NAMELY, TELEVISION PROGRAMMING RELATED TO HEALTH ISSUES; ENTERTAINMENT SERVICES, NAMELY, A WEBSITE FEATURING INFORMATION ABOUT ENTERTAINMENT PROGRAMMING IN THE FIELD OF HEALTH ISSUES AS THEY RELATE TO FOOD, PERSONAL RELATIONSHIPS, PARENTING, STYLE, BEAUTY, HOME AND HEALTH; AMUSEMENT PARK SERVICES; PROVIDING A WEBPAGE FOR VIEWING ENTERTAINMENT PROGRAMMING RELATED TO HEALTH CONCERNS; ENTERTAINMENT AND EDUCATION SERVICES, NAMELY, CONDUCTING PROGRAMS AND INITIATIVES IN THE NATURE OF WORKSHOPS, DEMONSTRATIONS, LECTURES, PRESENTATIONS AND FITNESS CLASSES RELATED TO HEALTH ISSUES; AND CONDUCTING HEALTH FAIRS AND EVENTS IN THE NATURE OF WORKSHOPS, DEMONSTRATIONS, LECTURES, PRESENTATIONS AND FITNESS CLASSES TO PROMOTE HEALTH, ALL FOR EDUCATIONAL AND ENTERTAINMENT PURPOSES (U.S. CLS. 100, 101 AND 107).

FIRST USE 6-14-2010; IN COMMERCE 6-14-2010.
HAI-LY LAM, EXAMINING ATTORNEY

SN 76-706,596. LOCICERO SR., JOSEPH D., BOCA RATON, FL. FILED 2-28-2011.

SN 77-182,870. THE RITZ HOTEL, LIMITED, PARIS CEDEX, FRANCE, FILED 5-16-2007.

RITZ ESCOFFIER**THE RIFFS**

THE MARK CONSISTS OF STANDARD CHARACTERS WITHOUT CLAIM TO ANY PARTICULAR FONT, STYLE, SIZE, OR COLOR.

FOR LIVE VOCAL AND INSTRUMENTAL PERFORMANCES BY A MUSICAL GROUP (U.S. CLS. 100, 101 AND 107).

FIRST USE 5-1-1964; IN COMMERCE 5-1-1964.
APRIL HESIK, EXAMINING ATTORNEY

THE MARK CONSISTS OF STANDARD CHARACTERS WITHOUT CLAIM TO ANY PARTICULAR FONT, STYLE, SIZE, OR COLOR.

OWNER OF FRANCE REG. NO. 3141927, DATED 1-16-2002, EXPIRES 1-16-2012.

FOR EDUCATIONAL SERVICES, NAMELY, CONDUCTING SEMINARS, WORKSHOPS, CLASSES, CONFERENCES AND SYMPOSIUMS IN THE FIELD OF COOKING; PRODUCTION OF DVD'S, VIDEOTAPES, TELEVISION PROGRAMS AND VIDEO CONTENT, NAMELY, MOTION PICTURES AND FILMS, FOR USE AND DISTRIBUTION ON WEBSITES IN THE FIELD OF COOKING (U.S. CLS. 100, 101 AND 107).

SETH A. RAPPAPORT, EXAMINING ATTORNEY

CLASS 41—(Continued).

SN 77-209,283. ROCKSTARZ ENTERTAINMENT GROUP INC., SNELLVILLE, GA. FILED 6-19-2007.

Rockstarz Entertainment Group Inc.

THE MARK CONSISTS OF STANDARD CHARACTERS WITHOUT CLAIM TO ANY PARTICULAR FONT, STYLE, SIZE, OR COLOR.

NO CLAIM IS MADE TO THE EXCLUSIVE RIGHT TO USE "ENTERTAINMENT GROUP INC.", APART FROM THE MARK AS SHOWN.

FOR ENTERTAINMENT IN THE NATURE OF FASHION SHOWS; ENTERTAINMENT IN THE NATURE OF LIVE PERFORMANCES BY RAP/ROCK ARTISTS; ENTERTAINMENT IN THE NATURE OF BMX SPORTS GAMES; ENTERTAINMENT, NAMELY, LIVE PERFORMANCES BY A MUSICAL BAND; ENTERTAINMENT SERVICES, NAMELY, CONDUCTING PARTIES; ENTERTAINMENT, NAMELY, LIVE PERFORMANCES BY MUSICAL BANDS (U.S. CLS. 100, 101 AND 107).

DEZMONA MIZELLE, EXAMINING ATTORNEY

SN 77-239,720. SCHMITTY SAYS, LLC, NEW YORK, NY. FILED 7-26-2007.

HOLLYWOOF

THE MARK CONSISTS OF STANDARD CHARACTERS WITHOUT CLAIM TO ANY PARTICULAR FONT, STYLE, SIZE, OR COLOR.

FOR ENTERTAINMENT, NAMELY, ONGOING SPECIAL VARIETY, NEWS, MUSIC OR COMEDY SHOWS AND PROGRAMS IN THE FIELD OF CHILDREN AND TEENAGER'S ENTERTAINMENT PRODUCED AND DISTRIBUTED OVER TELEVISION, MOTION PICTURES, INTERNET, DVD, CD, WIRELESS MEDIA AND OTHER DIGITAL MEDIA (U.S. CLS. 100, 101 AND 107).

TAMARA FRAZIER, EXAMINING ATTORNEY

CLASS 41—(Continued).

SN 77-296,664. COLORADO ROCKIES BASEBALL CLUB, LTD., DENVER, CO. FILED 10-4-2007.

ROCKTOBER

THE MARK CONSISTS OF STANDARD CHARACTERS WITHOUT CLAIM TO ANY PARTICULAR FONT, STYLE, SIZE, OR COLOR.

FOR ENTERTAINMENT SERVICES, NAMELY, BASEBALL GAMES, COMPETITIONS, TOURNAMENTS AND EXHIBITIONS RENDERED LIVE AND THROUGH BROADCAST MEDIA INCLUDING TELEVISION, RADIO, SATELLITE, WIRELESS, AUDIO AND VIDEO MEDIA, TELEPHONE, FIBER OPTICS, WIRELESS FIDELITY AND OTHER ELECTRONIC MEDIA AND VIA A GLOBAL COMPUTER NETWORK OR A COMMERCIAL ON-LINE SERVICE, MOBILE TELEPHONE OR OTHER ELECTRONIC OR DIGITAL COMMUNICATIONS NETWORK OR DEVICE; INFORMATION SERVICES, NAMELY, PROVIDING INFORMATION IN THE FIELD OF SPORTS, ENTERTAINMENT AND RELATED TOPICS, AND PROVIDING FOR INFORMATIONAL MESSAGES RELATING THERETO; ENTERTAINMENT SERVICES, NAMELY, PROVIDING MULTI-USER INTERACTIVE GAMES ALL VIA A GLOBAL COMPUTER NETWORK, MOBILE TELEPHONE OR OTHER ELECTRONIC OR DIGITAL COMMUNICATIONS NETWORK OR DEVICE, OR A COMMERCIAL ON-LINE SERVICE; EDUCATIONAL SERVICES IN THE NATURE OF BASEBALL SKILLS PROGRAMS, BASEBALL CAMPS, SEMINARS AND CLINICS OFFERED LIVE AND THROUGH ON-LINE INSTRUCTION; ENTERTAINMENT SERVICES, NAMELY, PRODUCTION OF PROGRAMMING BROADCAST VIA TELEVISION, RADIO AND A GLOBAL COMPUTER NETWORK OR A COMMERCIAL ON-LINE SERVICE; ORGANIZING COMMUNITY SPORTING EVENTS; ENTERTAINMENT SERVICES, NAMELY, PRODUCTION AND DISTRIBUTION OF PROGRAMMING BROADCAST VIA TELEVISION, RADIO, CABLE TRANSMISSION, SATELLITE TRANSMISSION, A GLOBAL COMPUTER NETWORK, MOBILE TELEPHONE OR OTHER ELECTRONIC OR DIGITAL COMMUNICATIONS NETWORK OR DEVICE; PRODUCTION OF DVDS AND VIDEOTAPES FEATURING SPORTS; LIVE PERFORMANCES BY COSTUMED CHARACTERS AND PERFORMANCES FEATURING COSTUMED OR CARTOON CHARACTERS EXHIBITED OVER TELEVISION, SATELLITE AND VIDEO MEDIA; PROVIDING FACILITIES FOR SPORTS EVENTS, TOURNAMENTS, COMPETITIONS, EXHIBITIONS, AND ENTERTAINMENT, NAMELY, PROVIDING SUCH EVENTS FOR PUBLIC EXHIBITION AND TELEVISION AND RADIO BROADCAST AND OTHER MEDIA DISTRIBUTION, AND PROVIDING OTHER CUSTOMARY STADIUM SERVICES, NAMELY, RENTAL OF STADIUM FACILITIES AND PROVIDING FACILITIES FOR STADIUM TOURS AND CONCERTS; ORGANIZING AND CONDUCTING FANTASY SPORTS, SPORTS CONTESTS AND SWEEPSTAKES; WEB SITE FEATURING SPORTS, ENTERTAINMENT AND RELATED TOPICS; PROVIDING A WEB SITE FEATURING SPORTS, ENTERTAINMENT AND RELATED TOPICS; FAN CLUBS; ORGANIZING AND CONDUCTING FESTIVALS FEATURING A VARIETY OF SPORTS AND ENTERTAINMENT ACTIVITIES; PUBLISHING OF ELECTRONIC PUBLICATIONS; PROVIDING ON-LINE NEWSLETTERS IN THE FIELD OF BASEBALL; ENTERTAINMENT SERVICES IN THE NATURE OF DISPLAYS OF BASEBALL, BASEBALL GAMES, BASEBALL EXHIBITIONS AND BASEBALL HISTORY; ENTERTAINMENT SERVICES IN THE NATURE OF HONORING PLAYERS AND FANS BY MEANS OF ENGRAVED BRICKS AND PANELS LOCATED IN A SPORTS AND ENTERTAINMENT FACILITY (U.S. CLS. 100, 101 AND 107).

JAY FLOWERS, EXAMINING ATTORNEY

CLASS 41—(Continued).

SN 77-642,426. HANEY, ROY E., DBA BLUE BUFFALO PUBLISHING, HAYWARD, CA. FILED 1-1-2009.



NO CLAIM IS MADE TO THE EXCLUSIVE RIGHT TO USE "PUBLISHING", APART FROM THE MARK AS SHOWN.

THE COLOR(S) BLACK AND WHITE IS/ARE CLAIMED AS A FEATURE OF THE MARK.

THE MARK CONSISTS OF A BLACK BACKGROUND WITH A WHITE BUFFALO IN THE CENTER. THE STYLIZED WORDS "BLUE BUFFALO PUBLISHING" ARE WHITE. THE STYLIZED WORDS "BLUE BUFFALO" ARE WRITTEN ABOVE THE WHITE BUFFALO AND THE STYLIZED WORD "PUBLISHING" IS WRITTEN BELOW THE WHITE BUFFALO.

FOR BOOK PUBLISHING (U.S. CLS. 100, 101 AND 107).
BERYL GARDNER, EXAMINING ATTORNEY

CLASS 41—(Continued).

SN 77-822,159. ACADEMY OF RADIOLOGY PHYSICIAN EXTENDERS, DBA ARPE, LANDER, WY. FILED S.R. 9-8-2009; AM. P.R. 6-7-2011.



NO CLAIM IS MADE TO THE EXCLUSIVE RIGHT TO USE "ACADEMY FOR RADIOLOGY PHYSICIAN EXTENDERS" AND "IMAGING", APART FROM THE MARK AS SHOWN.

THE COLOR(S) ROYAL BLUE, BLACK, GRAY AND WHITE IS/ARE CLAIMED AS A FEATURE OF THE MARK.

THE MARK CONSISTS OF A ROYAL BLUE SHIELD DESIGN OUTLINED IN BLACK AND CONTAINING THE WHITE WORDS "ACADEMY FOR RADIOLOGY PHYSICIAN EXTENDERS"; THE MARK FURTHER CONSISTS OF A GRAY BANNER DESIGN OUTLINED IN BLACK APPEARING ACROSS THE BOTTOM OF THE SHIELD; THE WORDING "IMAGING EXCELLENCE" APPEARS IN BLACK ACROSS THE CENTER PORTION OF THE BANNER AND IS FLANKED BY THE BLACK LETTERING "ARPE" AT THE RIGHT AND LEFT ENDS OF THE BANNER DESIGN; A WHITE OVAL DESIGN CONTAINING A BLACK STYLIZED ATOMIC SYMBOL APPEARS AT THE BOTTOM OF THE SHIELD DESIGN.

FOR EDUCATIONAL SERVICES, NAMELY, OFFERING ONLINE CONTINUING EDUCATION COURSES IN MEDICAL IMAGING; EDUCATIONAL SERVICES, NAMELY, OFFERING EDUCATIONAL SEMINARS AND CONFERENCES IN MEDICAL IMAGING; PROVIDING MENTORING TO HEALTH CARE WORKERS ON TOPICS RELATED TO MEDICAL IMAGING; PROVIDING MENTORING TO INDIVIDUALS ENROLLED IN MEDICAL IMAGING EDUCATIONAL PROGRAMS (U.S. CLS. 100, 101 AND 107).

FIRST USE 10-15-2008; IN COMMERCE 3-15-2009.
KEVIN CORWIN, EXAMINING ATTORNEY

SN 77-810,162. PRESTON, CANUTE, DBA DJ MONK, NEW YORK, NY. FILED 8-21-2009.

DJ Monk

THE MARK CONSISTS OF STANDARD CHARACTERS WITHOUT CLAIM TO ANY PARTICULAR FONT, STYLE, SIZE, OR COLOR.

NO CLAIM IS MADE TO THE EXCLUSIVE RIGHT TO USE "DJ", APART FROM THE MARK AS SHOWN.

THE NAME(S), PORTRAIT(S), AND/OR SIGNATURE(S) SHOWN IN THE MARK IDENTIFIES CANUTE PRESTON, WHOSE CONSENT(S) TO REGISTER IS MADE OF RECORD.

FOR DISC JOCKEYS FOR PARTIES AND SPECIAL EVENTS (U.S. CLS. 100, 101 AND 107).

FIRST USE 2-18-2005; IN COMMERCE 2-25-2005.
MICHAEL WEBSTER, EXAMINING ATTORNEY

CLASS 41—(Continued).

SN 77-827,926. GREATER DELAWARE VALLEY SOCIETY OF TRANSPLANT SURGEONS, PHILADELPHIA, PA. FILED 9-16-2009.



OWNER OF U.S. REG. NOS. 2,003,085, 2,447,571 AND OTHERS.

NO CLAIM IS MADE TO THE EXCLUSIVE RIGHT TO USE "DONOR PROGRAM" AND "FAMILY HOUSE", APART FROM THE MARK AS SHOWN.

THE COLOR(S) BLUE, WHITE, LIGHT GREEN AND BLACK IS/ARE CLAIMED AS A FEATURE OF THE MARK.

THE MARK CONSISTS OF A MASCOT WITH A BLUE HEAD, BLACK EYES ON A WHITE BACKGROUND, WHITE SMILE OUTLINED IN BLACK, A NOSE OUTLINED IN BLACK AND BLACK EYEBROWS. THE BODY CONSISTS OF A BLUE HEART ENCIRCLING A WHITE HEART OUTLINED IN BLACK. THE ARMS ARE WHITE WITH BLUE HANDS. THE LEGS ARE WHITE WITH BLUE AND WHITE SNEAKERS WITH BLACK OUTLINES. THE SHORTS ARE BLUE WITH A LIGHT GREEN STRIPE. THE WORDING "GIFT OF LIFE DONOR PROGRAM" IN BLACK LETTERING APPEARS ON THE WHITE PATCH ON THE LEFT SIDE OF THE SHORTS WITH A STYLIZED HUMAN IN THE SHAPE OF A HEART IN BLUE. ON THE RIGHT SIDE OF THE SHORTS, THE WORDING "GIFT OF LIFE FAMILY HOUSE" APPEARS IN BLACK LETTERING ON A WHITE BACKGROUND WITH A STYLIZED HUMAN IN THE SHAPE OF A HEART ON A LIGHT GREEN AND WHITE BACKGROUND. THE BLACK SHADING UNDERNEATH THE FEET IS BACKGROUND AND IS NOT PART OF THE MARK.

FOR ENTERTAINMENT IN THE NATURE OF LIVE PRESENTATIONS, PERFORMANCES, AND PUBLIC APPEARANCES BY A COSTUMED MASCOT TO EDUCATE PEOPLE ON ORGAN DONOR AWARENESS (U.S. CLS. 100, 101 AND 107).

FIRST USE 7-12-2008; IN COMMERCE 7-12-2008.

KATHLEEN M. VANSTON, EXAMINING ATTORNEY

CLASS 41—(Continued).

SN 77-844,047. GILLMAN, MATTHEW JOHN, MELBOURNE, AUSTRALIA, AND WHITE, JASON SAMUEL, MELBOURNE, AUSTRALIA, AND DOE, ALYSSA PAMELA, MELBOURNE, AUSTRALIA, FILED 10-8-2009.

car stereo wars

THE MARK CONSISTS OF STANDARD CHARACTERS WITHOUT CLAIM TO ANY PARTICULAR FONT, STYLE, SIZE, OR COLOR.

FOR ENTERTAINMENT SERVICES IN THE NATURE OF LIVE MUSICAL PERFORMANCES; ENTERTAINMENT SERVICES, NAMELY, DANCE EVENTS BY A RECORDING ARTIST; ENTERTAINMENT SERVICES, NAMELY, PROVIDING INFORMATION ABOUT A RECORDING ARTIST VIA AN ONLINE NETWORK; ENTERTAINMENT, NAMELY, LIVE MUSIC CONCERTS; MUSIC PRODUCTION SERVICES; MUSIC VIDEO PRODUCTION; PRODUCTION OF MUSICAL SOUND RECORDING; PRODUCTION OF SOUND AND MUSIC VIDEO RECORDINGS; PROVISION OF INFORMATION RELATING TO MUSIC (U.S. CLS. 100, 101 AND 107).

STEVEN JACKSON, EXAMINING ATTORNEY

SN 77-967,523. CENTER FOR INNOVATION & APPLIED DESIGN, HOLLAND, MI. FILED 3-24-2010.

NEWNORTH CENTER

THE MARK CONSISTS OF STANDARD CHARACTERS WITHOUT CLAIM TO ANY PARTICULAR FONT, STYLE, SIZE, OR COLOR.

NO CLAIM IS MADE TO THE EXCLUSIVE RIGHT TO USE "CENTER", APART FROM THE MARK AS SHOWN.

FOR EDUCATION SERVICES, NAMELY CONDUCTING CLASSES, SEMINARS, LECTURES, AND WORKSHOPS IN THE FIELDS OF BUSINESS INNOVATION PROCESS AND DESIGN-DRIVEN INNOVATION; BUSINESS TRAINING (U.S. CLS. 100, 101 AND 107).

BRIAN PINO, EXAMINING ATTORNEY

CLASS 41—(Continued).

SN 77-979,930. SUNDoulos WORLD MOTORSPORTS, ORANGE, CA. FILED 9-15-2009.

SUNDoulos

THE MARK CONSISTS OF STANDARD CHARACTERS WITHOUT CLAIM TO ANY PARTICULAR FONT, STYLE, SIZE, OR COLOR.

THE ENGLISH TRANSLATION OF THE ANCIENT GREEK WORD "SUNDoulos" IN THE MARK IS "FELLOW SLAVE".

FOR ENTERTAINMENT, NAMELY, A CONTINUING DOCUMENTARY SHOW ABOUT THE MOTORSPORTS PERFORMANCE INDUSTRY BROADCAST OVER RADIO, TELEVISION, SATELLITE, AUDIO, VIDEO, AND COMPUTER NETWORKS; ENTERTAINMENT SERVICES IN THE NATURE OF AUTOMOBILE RACING AND EXHIBITIONS; ENTERTAINMENT, NAMELY, PRODUCTION OF DOCUMENTARY SHOWS (U.S. CLS. 100, 101 AND 107).

FIRST USE 7-4-2004; IN COMMERCE 7-4-2004.
LAURA KOVALSKY, EXAMINING ATTORNEY

CLASS 41—(Continued).

SN 79-089,412. STAGEPOOL AB, SWEDEN, FILED 9-27-2010.



OWNER OF INTERNATIONAL REGISTRATION 0761493 DATED 7-9-2001, EXPIRES 7-9-2021.

THE MARK CONSISTS OF THE WORD "STAGEPOOL" IN STYLIZED FONT WITH A WAVY HORIZONTAL LINE ABOVE THE LETTERS "AGEPO" AND FOUR SQUARES ABOVE THE WAVY LINE.

FOR ENTERTAINMENT AND CULTURAL ACTIVITIES, NAMELY, THEATRICAL PRODUCTIONS, PROVIDING INFORMATION RELATING TO SPORTING, CULTURAL AND LIVE THEATRICAL PRODUCTIONS, LIVE MUSICAL PERFORMANCES AND ORGANIZATION OF SHOWS FOR CULTURAL PURPOSES (U.S. CLS. 100, 101 AND 107).

TINA BROWN, EXAMINING ATTORNEY

SN 78-925,311. SECURITY MEDIA CORPORATION, FEDERAL WAY, WA. FILED 7-10-2006.

SECURITY 2.0

THE MARK CONSISTS OF STANDARD CHARACTERS WITHOUT CLAIM TO ANY PARTICULAR FONT, STYLE, SIZE, OR COLOR.

FOR ONLINE ELECTRONIC PUBLISHING OF MAGAZINES; PUBLICATION OF ELECTRONIC MAGAZINES; PUBLISHING OF WEB MAGAZINES (U.S. CLS. 100, 101 AND 107).

ELLEN PERKINS, EXAMINING ATTORNEY

SN 79-095,546. BAYERISCHE MOTOREN WERKE AKTIENGESELLSCHAFT, FED REP GERMANY, FILED 3-8-2011.

BMW Driving Experience

THE MARK CONSISTS OF STANDARD CHARACTERS WITHOUT CLAIM TO ANY PARTICULAR FONT, STYLE, SIZE, OR COLOR.

PRIORITY DATE OF 11-24-2010 IS CLAIMED.
OWNER OF INTERNATIONAL REGISTRATION 1072473 DATED 3-8-2011, EXPIRES 3-8-2021.

OWNER OF U.S. REG. NOS. 613,465 AND 1,450,212.
NO CLAIM IS MADE TO THE EXCLUSIVE RIGHT TO USE "DRIVING EXPERIENCE", APART FROM THE MARK AS SHOWN.

FOR DRIVER SAFETY TRAINING (U.S. CLS. 100, 101 AND 107).
NAKIA HENRY, EXAMINING ATTORNEY

CLASS 41—(Continued).

SN 85-002,525. HYPNOTHERAPY NM, LLC, DBA BLISSBORN, ALBUQUERQUE, NM. FILED 3-30-2010.

Blissborn

THE MARK CONSISTS OF STANDARD CHARACTERS WITHOUT CLAIM TO ANY PARTICULAR FONT, STYLE, SIZE, OR COLOR.

FOR EDUCATION SERVICES, NAMELY, PROVIDING CLASSES, SEMINARS, WORKSHOPS, FEATURING INFORMATION IN THE FIELD OF CHILD BIRTH, CORRESPONDENCE COURSES FEATURING INFORMATION ABOUT CHILD BIRTH, AND DISTRIBUTION OF COURSE MATERIAL IN CONNECTION THEREWITH; EDUCATIONAL SERVICES, NAMELY, CONDUCTING CLASSES, SEMINARS, WORKSHOPS, FEATURING INFORMATION IN THE FIELD OF CHILD BIRTH, CORRESPONDENCE COURSES IN THE FIELD OF CHILD BIRTH, AND DISTRIBUTION OF TRAINING MATERIALS IN CONNECTION THEREWITH (U.S. CLS. 100, 101 AND 107).

FIRST USE 1-2-2010; IN COMMERCE 1-2-2010.
DAWN FELDMAN, EXAMINING ATTORNEY

SN 85-009,655. CERTIFICATION COACH, INC., TAMPA, FL. FILED 4-8-2010.

COMPUTER COACH

THE MARK CONSISTS OF STANDARD CHARACTERS WITHOUT CLAIM TO ANY PARTICULAR FONT, STYLE, SIZE, OR COLOR.

OWNER OF U.S. REG. NO. 1,850,069.
NO CLAIM IS MADE TO THE EXCLUSIVE RIGHT TO USE "COMPUTER", APART FROM THE MARK AS SHOWN.

SEC. 2(F).
FOR COMPUTER EDUCATION TRAINING SERVICES (U.S. CLS. 100, 101 AND 107).
FIRST USE 5-15-1992; IN COMMERCE 5-15-1992.
HEATHER SAPP, EXAMINING ATTORNEY

SN 85-014,118. WORLDFLIX, MARINA DEL REY, CA. FILED 4-14-2010.

WorldFlix

THE MARK CONSISTS OF STANDARD CHARACTERS WITHOUT CLAIM TO ANY PARTICULAR FONT, STYLE, SIZE, OR COLOR.

FOR PRODUCTION AND DISTRIBUTION OF TELEVISION SHOWS AND MOVIES (U.S. CLS. 100, 101 AND 107).

FIRST USE 2-1-2007; IN COMMERCE 2-15-2007.
EMILY CHUO, EXAMINING ATTORNEY

CLASS 41—(Continued).

SN 85-021,884. GLAXO GROUP LIMITED, GREENFORD, MIDDLESEX, UNITED KINGDOM, FILED 4-23-2010.

ECLIPSE

THE MARK CONSISTS OF STANDARD CHARACTERS WITHOUT CLAIM TO ANY PARTICULAR FONT, STYLE, SIZE, OR COLOR.

PRIORITY CLAIMED UNDER SEC. 44(D) ON ERPN CMNTY TM OFC APPLICATION NO. 009015447, FILED 4-9-2010, REG. NO. 009015447, DATED 9-27-2010, EXPIRES 4-9-2020.

FOR EDUCATIONAL AND TRAINING SERVICES, NAMELY, CONDUCTING SEMINARS IN THE FIELD OF TREATMENT AND MANAGEMENT OF RESPIRATORY DISEASES AND DISORDERS AND DISTRIBUTING COURSE MATERIALS IN CONNECTION THEREWITH (U.S. CLS. 100, 101 AND 107).

BARBARA BROWN, EXAMINING ATTORNEY

SN 85-023,678. SALLMAN, JASON E, DBA SURE BET POKER INC, WESLEY CHAPEL, FL. FILED 4-26-2010.

Sure Bet Poker

THE MARK CONSISTS OF STANDARD CHARACTERS WITHOUT CLAIM TO ANY PARTICULAR FONT, STYLE, SIZE, OR COLOR.

NO CLAIM IS MADE TO THE EXCLUSIVE RIGHT TO USE "POKER", APART FROM THE MARK AS SHOWN.

FOR PROVIDING ON-LINE POKER GAMES (U.S. CLS. 100, 101 AND 107).

MATTHEW PAPPAS, EXAMINING ATTORNEY

CLASS 41—(Continued).

SN 85-024,229. HEALTHIEST EMPLOYER, LLC, INDIANAPOLIS, IN. FILED 4-27-2010.



NO CLAIM IS MADE TO THE EXCLUSIVE RIGHT TO USE "HEALTHIEST EMPLOYERS" AND "WINNER", APART FROM THE MARK AS SHOWN.

THE COLOR(S) GREEN, WHITE AND YELLOW IS/ARE CLAIMED AS A FEATURE OF THE MARK.

THE MARK CONSISTS OF A RECTANGULAR OVAL DIVIDED INTO THIRDS, OF WHICH THE TOP IS SHADED GREEN, THE MIDDLE SECTION IS WHITE, AND THE LOWER SECTION IS YELLOW. THE THREE SECTIONS ARE SURROUNDED BY A BORDER OF GREEN/WHITE/GREEN. IN THE TOP GREEN SECTION, THE TERMS "HEALTHIEST EMPLOYERS" APPEARS, WITH "HE" IN A GREEN DESIGN AND "HEALTHIEST EMPLOYERS" IS IN WHITE. IN THE BOTTOM YELLOW PORTION, THE WORD "WINNER" APPEARS IN WHITE.

FOR PROVIDING RECOGNITION AND INCENTIVES TO EMPLOYERS BY WAY OF AWARDS TO DEMONSTRATE EXCELLENCE IN THE FIELD OF PROVIDING HEALTHY WORKPLACES (U.S. CLS. 100, 101 AND 107).

FIRST USE 1-14-2009; IN COMMERCE 1-14-2009.

SANJEEV VOHRA, EXAMINING ATTORNEY

SN 85-048,536. NATIONAL BLACK ARTS FESTIVAL, INC., ATLANTA, GA. FILED 5-26-2010.

**NATIONAL BLACK ARTS
FESTIVAL**

THE MARK CONSISTS OF STANDARD CHARACTERS WITHOUT CLAIM TO ANY PARTICULAR FONT, STYLE, SIZE, OR COLOR.

NO CLAIM IS MADE TO THE EXCLUSIVE RIGHT TO USE "ARTS FESTIVAL", APART FROM THE MARK AS SHOWN.

SEC. 2(F).

FOR ENTERTAINMENT AND EDUCATIONAL SERVICES, NAMELY, ARRANGING AND CONDUCTING DANCE, MUSIC, THEATER, FILM, VISUAL ART, AND LITERARY ARTS PRESENTATIONS (U.S. CLS. 100, 101 AND 107).

FIRST USE 6-0-1988; IN COMMERCE 6-0-1988.

MICHELLE DUBOIS, EXAMINING ATTORNEY

CLASS 41—(Continued).

SN 85-049,434. FLYNN WORLD, LLC, ROSWELL, GA. FILED 5-27-2010.

GREAT GAME OF GOLF

THE MARK CONSISTS OF STANDARD CHARACTERS WITHOUT CLAIM TO ANY PARTICULAR FONT, STYLE, SIZE, OR COLOR.

NO CLAIM IS MADE TO THE EXCLUSIVE RIGHT TO USE "GOLF", APART FROM THE MARK AS SHOWN.

FOR PROVIDING A WEBSITE FOR GOLFERS TO LOCATE INFORMATION ABOUT GOLF COURSES AND GOLF TOURNAMENTS; PROVIDING A WEBSITE FEATURING INFORMATION ABOUT GOLF AND GOLF INSTRUCTIONS; PROVIDING INFORMATION TO GOLFERS CONCERNING RESERVATION OF TEE TIMES AND RATES AT GOLF COURSES; PROVIDING A WEBSITE CONCERNING NEWS AND INFORMATION ON THE SPORT OF GOLF; ELECTRONIC PUBLISHING SERVICES, NAMELY, PUBLICATION OF TEXT AND GRAPHIC WORKS OF OTHERS VIA THE INTERNET FEATURING INFORMATION IN THE FIELD OF GOLF AND GOLFING; CONDUCTING ONLINE FANTASY SPORTS GAMES, COMPUTER GAMES AND CONTESTS; EDUCATIONAL AND ENTERTAINMENT SERVICES, NAMELY, A CONTINUING PROGRAM ABOUT GOLF BROADCAST OVER RADIO, TELEVISION, SATELLITE, AUDIO, VIDEO AND COMPUTER NETWORKS (U.S. CLS. 100, 101 AND 107).

TRACY FLETCHER, EXAMINING ATTORNEY

SN 85-052,300. NO STARCH PRESS, INC., SAN FRANCISCO, CA. FILED 6-1-2010.



**no starch
press**

NO CLAIM IS MADE TO THE EXCLUSIVE RIGHT TO USE "PRESS", APART FROM THE MARK AS SHOWN.

THE MARK CONSISTS OF AN IRON WITH A STAR IN THE MIDDLE AND THE WORDS "NO STARCH PRESS". FOR PUBLICATION OF BOOKS (U.S. CLS. 100, 101 AND 107).

FIRST USE 9-1-2007; IN COMMERCE 9-1-2007.

NAKIA HENRY, EXAMINING ATTORNEY

CLASS 41—(Continued).

SN 85-066,800. SALLMAN , JASON E. DBA SURE BET POKER INC, WESLEY CHAPEL, FL. FILED 6-18-2010.

surebetpoker.com

THE MARK CONSISTS OF STANDARD CHARACTERS WITHOUT CLAIM TO ANY PARTICULAR FONT, STYLE, SIZE, OR COLOR.

FOR PROVIDING ON-LINE POKER GAMES (U.S. CLS. 100, 101 AND 107).

MATTHEW PAPPAS, EXAMINING ATTORNEY

SN 85-106,158. WRITERS RESOURCE GROUP, INC., PALOS VERDES ESTATES, CA. FILED 8-12-2010.

OUR LADY OF PERPETUAL
CORRECTNESS

THE MARK CONSISTS OF STANDARD CHARACTERS WITHOUT CLAIM TO ANY PARTICULAR FONT, STYLE, SIZE, OR COLOR.

FOR EDUCATION SERVICES, NAMELY, PROVIDING ON-LINE CLASSES, SEMINARS, AND WORKSHOPS IN THE FIELD OF INSTRUCTION ON PROPER ENGLISH-LANGUAGE USAGE, GRAMMAR, AND WRITING SKILLS; ON-LINE ELECTRONIC NEWSLETTERS DELIVERED BY E-MAIL IN THE FIELD OF INSTRUCTION ON PROPER ENGLISH-LANGUAGE USAGE, GRAMMAR, AND WRITING SKILLS; ON-LINE JOURNALS, NAMELY, BLOGS FEATURING INSTRUCTION ON PROPER ENGLISH-LANGUAGE USAGE, GRAMMAR, AND WRITING SKILLS; PROVIDING A WEBSITE FEATURING NON-DOWNLOADABLE PUBLICATIONS IN THE NATURE OF NEWSLETTERS IN THE FIELD OF INSTRUCTION ON PROPER ENGLISH-LANGUAGE USAGE, GRAMMAR, AND WRITING SKILLS (U.S. CLS. 100, 101 AND 107).

FIRST USE 1-20-2010; IN COMMERCE 1-20-2010.

JOHN GARTNER, EXAMINING ATTORNEY

CLASS 41—(Continued).

SN 85-106,192. WRITERS RESOURCE GROUP, INC., PALOS VERDES ESTATES, CA. FILED 8-12-2010.

SISTER MARY PAT

THE MARK CONSISTS OF STANDARD CHARACTERS WITHOUT CLAIM TO ANY PARTICULAR FONT, STYLE, SIZE, OR COLOR.

THE NAME(S), PORTRAIT(S), AND/OR SIGNATURE(S) SHOWN IN THE MARK DOES NOT IDENTIFY A PARTICULAR LIVING INDIVIDUAL.

FOR EDUCATION SERVICES, NAMELY, PROVIDING ON-LINE CLASSES, SEMINARS, AND WORKSHOPS IN THE FIELD OF INSTRUCTION ON PROPER ENGLISH-LANGUAGE USAGE, GRAMMAR, AND WRITING SKILLS; ON-LINE ELECTRONIC NEWSLETTERS DELIVERED BY E-MAIL IN THE FIELD OF INSTRUCTION ON PROPER ENGLISH-LANGUAGE USAGE, GRAMMAR, AND WRITING SKILLS; ON-LINE JOURNALS, NAMELY, BLOGS FEATURING INSTRUCTION ON PROPER ENGLISH-LANGUAGE USAGE, GRAMMAR, AND WRITING SKILLS; PROVIDING A WEBSITE FEATURING NON-DOWNLOADABLE PUBLICATIONS IN THE NATURE OF NEWSLETTERS IN THE FIELD OF INSTRUCTION ON PROPER ENGLISH-LANGUAGE USAGE, GRAMMAR, AND WRITING SKILLS (U.S. CLS. 100, 101 AND 107).

FIRST USE 1-20-2010; IN COMMERCE 1-20-2010.

JOHN GARTNER, EXAMINING ATTORNEY

SN 85-110,612. BAADA BOOM ENTERTAINMENT LLC, CENTURY CITY, CA. FILED 8-18-2010.

BAADABOOM
ENTERTAINMENT

NO CLAIM IS MADE TO THE EXCLUSIVE RIGHT TO USE "ENTERTAINMENT", APART FROM THE MARK AS SHOWN.

THE MARK CONSISTS OF THE WORD "BAADABOOM" WRITTEN IN UNEVENLY PLACED LETTERS ABOVE THE WORD "ENTERTAINMENT".

FOR PROVIDING AN INTERNET WEBSITE FEATURING CONTENT CREATED BY MUSIC ARTISTS; PROVIDING AN INTERNET WEBSITE FEATURING CONTENT CREATED BY MUSIC ARTISTS, NAMELY, MUSIC, PHOTOGRAPHS, ART AND LYRICS; PROVIDING LINKS TO THE WEBSITES OF OTHERS IN THE FIELD OF MUSIC AND MUSICAL ARTISTS; ENTERTAINMENT SERVICES, NAMELY, PROVIDING A WEBSITE FEATURING INFORMATION ABOUT MUSICAL ARTISTS; PROVIDING A MEMBERS ONLY SUBSCRIPTION INTERNET WEBSITE FEATURING CONTENT CREATED BY MUSIC ARTISTS, NAMELY, MUSIC, PHOTOGRAPHS, ART AND LYRICS; PROVIDING LINKS TO THE WEBSITES OF OTHERS IN THE FIELD OF MUSIC AND MUSICAL ARTISTS VIA A MEMBERS ONLY SUBSCRIPTION WEBSITE; ENTERTAINMENT SERVICES, NAMELY, PROVIDING A MEMBERS ONLY SUBSCRIPTION WEBSITE FEATURING INFORMATION ABOUT MUSICAL ARTISTS (U.S. CLS. 100, 101 AND 107).

KELLEY WELLS, EXAMINING ATTORNEY

CLASS 41—(Continued).

SN 85-111,937. CLARK STATE COMMUNITY COLLEGE, SPRINGFIELD, OH. FILED 8-20-2010.

Project Jericho

THE MARK CONSISTS OF STANDARD CHARACTERS WITHOUT CLAIM TO ANY PARTICULAR FONT, STYLE, SIZE, OR COLOR.

FOR INSTRUCTION IN THE FIELD OF ARTS; PROVIDING AFTER SCHOOL EDUCATIONAL PROGRAMS FOR CHILDREN IN GRADES PRESCHOOL THROUGH 12 (U.S. CLS. 100, 101 AND 107).

FIRST USE 1-1-1999; IN COMMERCE 1-1-1999,
SUSAN RICHARDS, EXAMINING ATTORNEY

SN 85-113,324. TENNIS PROPERTIES B.V., HEENVLIET, NETHERLANDS, FILED 8-23-2010.

TPBV TENNIS MASTERS

THE MARK CONSISTS OF STANDARD CHARACTERS WITHOUT CLAIM TO ANY PARTICULAR FONT, STYLE, SIZE, OR COLOR.

OWNER OF ERPN CMNTY TM OFC REG. NO. 9506866, DATED 4-26-2011, EXPIRES 11-9-2020.

OWNER OF U.S. REG. NO. 2,963,884.

NO CLAIM IS MADE TO THE EXCLUSIVE RIGHT TO USE "TENNIS", APART FROM THE MARK AS SHOWN.

FOR ORGANIZATION OF SPORTS COMPETITIONS; ORGANIZATION OF EVENTS FOR CULTURAL PURPOSES; ENTERTAINMENT IN THE NATURE OF TENNIS TOURNAMENTS; TENNIS INSTRUCTION; AND EDUCATIONAL SERVICES, NAMELY, CONDUCTING CLASSES IN THE FIELD OF TENNIS (U.S. CLS. 100, 101 AND 107).

SUE LAWRENCE, EXAMINING ATTORNEY

SN 85-121,421. BULGER, MARK, CITRUS HEIGHTS, CA. FILED 9-2-2010.

THE FUNKY BLUE DEVILS

THE MARK CONSISTS OF STANDARD CHARACTERS WITHOUT CLAIM TO ANY PARTICULAR FONT, STYLE, SIZE, OR COLOR.

FOR ENTERTAINMENT SERVICES IN THE NATURE OF LIVE MUSICAL PERFORMANCES (U.S. CLS. 100, 101 AND 107).

CHRIS WELLS, EXAMINING ATTORNEY

CLASS 41—(Continued).

SN 85-121,423. MCCARTHY, LARRY, CHULA VISTA, CA. FILED 9-2-2010.

GAME DOME

THE MARK CONSISTS OF STANDARD CHARACTERS WITHOUT CLAIM TO ANY PARTICULAR FONT, STYLE, SIZE, OR COLOR.

NO CLAIM IS MADE TO THE EXCLUSIVE RIGHT TO USE "GAME", APART FROM THE MARK AS SHOWN.

FOR VIDEO COMPUTER ARCADE SERVICES; AMUSEMENT ARCADES (U.S. CLS. 100, 101 AND 107).

CHRIS WELLS, EXAMINING ATTORNEY

SN 85-124,571. CASTRO-HERRERA, YUSDANY, SAN DIEGO, CA. FILED 9-8-2010.

HOUSTON GAMBLERS

THE MARK CONSISTS OF STANDARD CHARACTERS WITHOUT CLAIM TO ANY PARTICULAR FONT, STYLE, SIZE, OR COLOR.

NO CLAIM IS MADE TO THE EXCLUSIVE RIGHT TO USE "HOUSTON", APART FROM THE MARK AS SHOWN.

FOR ENTERTAINMENT IN THE NATURE OF FOOTBALL GAMES; ENTERTAINMENT IN THE NATURE OF ORGANIZING, COORDINATING, AND ARRANGING ATHLETIC COMPETITIONS; ENTERTAINMENT IN THE NATURE OF FOOTBALL GAMES AND EXHIBITIONS; ENTERTAINMENT IN THE NATURE OF PROVIDING SPORTS AND ENTERTAINMENT INFORMATION; ENTERTAINMENT IN THE NATURE OF LIVE PERFORMANCES BY A FOOTBALL TEAM; ENTERTAINMENT IN THE NATURE OF THE PRESENTATION OF LIVE SHOWS FEATURING ATHLETIC GAMES, EXHIBITIONS AND COMPETITIONS; ORGANIZATION OF SPORTS EVENTS IN THE FIELD OF FOOTBALL; ORGANIZING COMMUNITY SPORTING AND CULTURAL EVENTS; PROVIDING NEWS AND INFORMATION IN THE FIELD OF SPORTS; PROVISION OF INFORMATION RELATING TO SPORTS AND SPORTING EVENTS (U.S. CLS. 100, 101 AND 107).

SAIMA MAKHDOM, EXAMINING ATTORNEY

CLASS 41—(Continued).

SN 85-124,572. CASTRO-HERRERA, YUSDANY, SAN DIEGO, CA. FILED 9-8-2010.

BAY AREA INVADERS

THE MARK CONSISTS OF STANDARD CHARACTERS WITHOUT CLAIM TO ANY PARTICULAR FONT, STYLE, SIZE, OR COLOR.

NO CLAIM IS MADE TO THE EXCLUSIVE RIGHT TO USE "BAY AREA", APART FROM THE MARK AS SHOWN.

FOR ENTERTAINMENT IN THE NATURE OF FOOTBALL GAMES; ENTERTAINMENT IN THE NATURE OF ORGANIZING, COORDINATING, AND ARRANGING ATHLETIC COMPETITIONS; ENTERTAINMENT IN THE NATURE OF FOOTBALL GAMES AND EXHIBITIONS; ENTERTAINMENT IN THE NATURE OF PROVIDING SPORTS AND ENTERTAINMENT INFORMATION; ENTERTAINMENT IN THE NATURE OF LIVE PERFORMANCES BY A FOOTBALL TEAM; ENTERTAINMENT IN THE NATURE OF THE PRESENTATION OF LIVE SHOWS FEATURING ATHLETIC GAMES, EXHIBITIONS AND COMPETITIONS; ORGANIZATION OF SPORTS EVENTS IN THE FIELD OF FOOTBALL; ORGANIZING COMMUNITY SPORTING AND CULTURAL EVENTS; PROVIDING NEWS AND INFORMATION IN THE FIELD OF SPORTS; PROVISION OF INFORMATION RELATING TO SPORTS AND SPORTING EVENTS (U.S. CLS. 100, 101 AND 107).

SAIMA MAKHDOOM, EXAMINING ATTORNEY

CLASS 41—(Continued).

SN 85-124,574. CASTRO-HERRERA, YUSDANY, SAN DIEGO, CA. FILED 9-8-2010.

TAMPA BAY BANDITS

THE MARK CONSISTS OF STANDARD CHARACTERS WITHOUT CLAIM TO ANY PARTICULAR FONT, STYLE, SIZE, OR COLOR.

NO CLAIM IS MADE TO THE EXCLUSIVE RIGHT TO USE "TAMPA BAY", APART FROM THE MARK AS SHOWN.

FOR ENTERTAINMENT IN THE NATURE OF FOOTBALL GAMES; ENTERTAINMENT IN THE NATURE OF ORGANIZING, COORDINATING, AND ARRANGING ATHLETIC COMPETITIONS; ENTERTAINMENT IN THE NATURE OF FOOTBALL GAMES AND EXHIBITIONS; ENTERTAINMENT IN THE NATURE OF PROVIDING SPORTS AND ENTERTAINMENT INFORMATION; ENTERTAINMENT IN THE NATURE OF LIVE PERFORMANCES BY A FOOTBALL TEAM; ENTERTAINMENT IN THE NATURE OF THE PRESENTATION OF LIVE SHOWS FEATURING ATHLETIC GAMES, EXHIBITIONS AND COMPETITIONS; ORGANIZATION OF SPORTS EVENTS IN THE FIELD OF FOOTBALL; ORGANIZING COMMUNITY SPORTING AND CULTURAL EVENTS; PROVIDING NEWS AND INFORMATION IN THE FIELD OF SPORTS; PROVISION OF INFORMATION RELATING TO SPORTS AND SPORTING EVENTS (U.S. CLS. 100, 101 AND 107).

SAIMA MAKHDOOM, EXAMINING ATTORNEY

SN 85-124,573. CASTRO-HERRERA, YUSDANY, SAN DIEGO, CA. FILED 9-8-2010.

ARIZONA WRANGLERS

THE MARK CONSISTS OF STANDARD CHARACTERS WITHOUT CLAIM TO ANY PARTICULAR FONT, STYLE, SIZE, OR COLOR.

NO CLAIM IS MADE TO THE EXCLUSIVE RIGHT TO USE "ARIZONA", APART FROM THE MARK AS SHOWN.

FOR ENTERTAINMENT IN THE NATURE OF FOOTBALL GAMES; ENTERTAINMENT IN THE NATURE OF ORGANIZING, COORDINATING, AND ARRANGING ATHLETIC COMPETITIONS; ENTERTAINMENT IN THE NATURE OF FOOTBALL GAMES AND EXHIBITIONS; ENTERTAINMENT IN THE NATURE OF PROVIDING SPORTS AND ENTERTAINMENT INFORMATION; ENTERTAINMENT IN THE NATURE OF LIVE PERFORMANCES BY A FOOTBALL TEAM; ENTERTAINMENT IN THE NATURE OF THE PRESENTATION OF LIVE SHOWS FEATURING ATHLETIC GAMES, EXHIBITIONS AND COMPETITIONS; ORGANIZATION OF SPORTS EVENTS IN THE FIELD OF FOOTBALL; ORGANIZING COMMUNITY SPORTING AND CULTURAL EVENTS; PROVIDING NEWS AND INFORMATION IN THE FIELD OF SPORTS; PROVISION OF INFORMATION RELATING TO SPORTS AND SPORTING EVENTS (U.S. CLS. 100, 101 AND 107).

SAIMA MAKHDOOM, EXAMINING ATTORNEY

SN 85-124,576. CASTRO-HERRERA, YUSDANY, SAN DIEGO, CA. FILED 9-8-2010.

WASHINGTON FEDERALS

THE MARK CONSISTS OF STANDARD CHARACTERS WITHOUT CLAIM TO ANY PARTICULAR FONT, STYLE, SIZE, OR COLOR.

NO CLAIM IS MADE TO THE EXCLUSIVE RIGHT TO USE "WASHINGTON", APART FROM THE MARK AS SHOWN.

FOR ENTERTAINMENT IN THE NATURE OF FOOTBALL GAMES; ENTERTAINMENT IN THE NATURE OF ORGANIZING, COORDINATING, AND ARRANGING ATHLETIC COMPETITIONS; ENTERTAINMENT IN THE NATURE OF FOOTBALL GAMES AND EXHIBITIONS; ENTERTAINMENT IN THE NATURE OF PROVIDING SPORTS AND ENTERTAINMENT INFORMATION; ENTERTAINMENT IN THE NATURE OF LIVE PERFORMANCES BY A FOOTBALL TEAM; ENTERTAINMENT IN THE NATURE OF THE PRESENTATION OF LIVE SHOWS FEATURING ATHLETIC GAMES, EXHIBITIONS AND COMPETITIONS; ORGANIZATION OF SPORTS EVENTS IN THE FIELD OF FOOTBALL; ORGANIZING COMMUNITY SPORTING AND CULTURAL EVENTS; PROVIDING NEWS AND INFORMATION IN THE FIELD OF SPORTS; PROVISION OF INFORMATION RELATING TO SPORTS AND SPORTING EVENTS (U.S. CLS. 100, 101 AND 107).

SAIMA MAKHDOOM, EXAMINING ATTORNEY

CLASS 41—(Continued).

SN 85-124,579. CASTRO-HERRERA, YUSDANY, SAN DIEGO, CA. FILED 9-8-2010.

JACKSONVILLE BULLS

THE MARK CONSISTS OF STANDARD CHARACTERS WITHOUT CLAIM TO ANY PARTICULAR FONT, STYLE, SIZE, OR COLOR.

NO CLAIM IS MADE TO THE EXCLUSIVE RIGHT TO USE "JACKSONVILLE", APART FROM THE MARK AS SHOWN.

FOR ENTERTAINMENT IN THE NATURE OF FOOTBALL GAMES; ENTERTAINMENT IN THE NATURE OF ORGANIZING, COORDINATING, AND ARRANGING ATHLETIC COMPETITIONS; ENTERTAINMENT IN THE NATURE OF FOOTBALL GAMES AND EXHIBITIONS; ENTERTAINMENT IN THE NATURE OF PROVIDING SPORTS AND ENTERTAINMENT INFORMATION; ENTERTAINMENT IN THE NATURE OF LIVE PERFORMANCES BY A FOOTBALL TEAM; ENTERTAINMENT IN THE NATURE OF THE PRESENTATION OF LIVE SHOWS FEATURING ATHLETIC GAMES, EXHIBITIONS AND COMPETITIONS; ORGANIZATION OF SPORTS EVENTS IN THE FIELD OF FOOTBALL; ORGANIZING COMMUNITY SPORTING AND CULTURAL EVENTS; PROVIDING NEWS AND INFORMATION IN THE FIELD OF SPORTS; PROVISION OF INFORMATION RELATING TO SPORTS AND SPORTING EVENTS (U.S. CLS. 100, 101 AND 107).

SAIMA MAKHDUM, EXAMINING ATTORNEY

SN 85-127,585. TI CAINE, SHERMAN OAKS, CA. FILED 9-11-2010.

The Power of The Future

THE MARK CONSISTS OF STANDARD CHARACTERS WITHOUT CLAIM TO ANY PARTICULAR FONT, STYLE, SIZE, OR COLOR.

FOR EDUCATIONAL SERVICES, NAMELY, CONDUCTING TRAINING AND COACHING FOR GROUPS AND INDIVIDUALS, SEMINARS, RETREATS, TELESEMINARS, WEBINARS, PODCASTS AND PROGRAMS IN THE FIELDS OF PERSONAL GROWTH, SELF IMPROVEMENT, SUCCESS TRAINING, HEALING AND HEALTH, PSYCHOLOGY, CAREER AND ORGANIZATIONAL DEVELOPMENT, HYPNOTHERAPY, GUIDED VISUALIZATION, RELATIONSHIP AND FAMILY IMPROVEMENT, AND INTERPERSONAL COMMUNICATION, THAT IS LIVE OR ACCESSIBLE ON-LINE, BY PHONE, INTERNET RADIO, BROADCAST RADIO AND TELEVISION; PUBLISHING OF PRINTED BOOKS, WORKBOOKS, DIGITAL BOOKS; PRODUCTION OF VIDEO AND AUDIO RECORDINGS, NAMELY, CD, MP3, MP4, ELECTRONIC AND DIGITAL AUDIO AND VIDEO RECORDINGS; EDUCATIONAL SERVICES, NAMELY, PROFESSIONAL COACHING OF TEACHERS IN THE FIELDS OF PERSONAL GROWTH, SELF IMPROVEMENT, SUCCESS TRAINING, HEALING AND HEALTH, PSYCHOLOGY, CAREER AND ORGANIZATIONAL DEVELOPMENT, HYPNOTHERAPY, GUIDED VISUALIZATION, RELATIONSHIP AND FAMILY IMPROVEMENT, AND INTERPERSONAL COMMUNICATION ON A REAL-TIME BASIS DURING CLASSROOM INSTRUCTION (U.S. CLS. 100, 101 AND 107).

FIRST USE 3-1-2002; IN COMMERCE 3-1-2002.

TARA PATE, EXAMINING ATTORNEY

CLASS 41—(Continued).

SN 85-127,980. MAINE MUNICIPAL ASSOCIATION, AUGUSTA, ME. FILED 9-13-2010.

LOCAL GOVERNMENT
begins with YOU

NO CLAIM IS MADE TO THE EXCLUSIVE RIGHT TO USE "LOCAL GOVERNMENT", APART FROM THE MARK AS SHOWN.

THE MARK CONSISTS OF THE PHRASE "LOCAL GOVERNMENT BEGINS WITH YOU" IN FANCIFUL SCRIPT.

FOR PROVIDING EDUCATIONAL SERVICES, NAMELY, ONLINE AND IN PERSON CLASSES, SEMINARS AND WORKSHOPS IN THE FIELD OF LOCAL GOVERNMENTAL ISSUES, POLICIES AND PROCEDURES AND DISTRIBUTION OF COURSE AND EDUCATIONAL MATERIALS IN CONNECTION THEREWITH (U.S. CLS. 100, 101 AND 107).

FIRST USE 7-31-2010; IN COMMERCE 7-31-2010.

LINDA ORNDORFF, EXAMINING ATTORNEY

SN 85-128,300. EDISONLEARNING, INC., NEW YORK, NY. FILED 9-13-2010.

EdisonLearning Alliance

THE MARK CONSISTS OF STANDARD CHARACTERS WITHOUT CLAIM TO ANY PARTICULAR FONT, STYLE, SIZE, OR COLOR.

OWNER OF U.S. REG. NOS. 3,100,714, 3,787,958 AND 3,787,959.

NO CLAIM IS MADE TO THE EXCLUSIVE RIGHT TO USE "ALLIANCE", APART FROM THE MARK AS SHOWN.

FOR PROVIDING A CUSTOMIZED EDUCATIONAL CONSULTING SERVICE, NAMELY, CONSULTATION IN THE FIELD OF K-12 EDUCATIONAL SYSTEMS DEDICATED TO HELPING SCHOOLS AND SCHOOL DISTRICTS IMPROVE ACHIEVEMENT AND MEET ADEQUATE YEARLY PROGRESS (AYP) TARGETS UNDER THE NO CHILD LEFT BEHIND ACT; ARRANGING PROFESSIONAL WORKSHOPS AND TRAINING COURSES; PROVIDING EDUCATIONAL MENTORING SERVICES AND PROGRAMS IN THE FIELD OF HELPING SCHOOLS AND SCHOOL DISTRICTS IMPROVE ACHIEVEMENT AND MEET ADEQUATE YEARLY PROGRESS (AYP) TARGETS UNDER THE NO CHILD LEFT BEHIND ACT (U.S. CLS. 100, 101 AND 107).

FIRST USE 7-1-2008; IN COMMERCE 7-1-2008.

GINA FINK, EXAMINING ATTORNEY

CLASS 41—(Continued).

SN 85-128,764. BABY DREAM PHOTOGRAPHY, LLC., ISSAQUAH, WA. FILED 9-14-2010.

BABY DREAM

THE MARK CONSISTS OF STANDARD CHARACTERS WITHOUT CLAIM TO ANY PARTICULAR FONT, STYLE, SIZE, OR COLOR.

NO CLAIM IS MADE TO THE EXCLUSIVE RIGHT TO USE "BABY", APART FROM THE MARK AS SHOWN.

FOR PHOTOGRAPHY SERVICES; PHOTOGRAPHY CONSULTING AND EDITING (U.S. CLS. 100, 101 AND 107).

FIRST USE 1-1-2007; IN COMMERCE 1-1-2007.

VERNA BETH RIRIE, EXAMINING ATTORNEY

CLASS 41—(Continued).

SN 85-130,700. JONES, MATTHEW WAYNE, DBA CAROLINA ENTERTAINMENT, SPRING LAKE, NC. FILED 9-15-2010.

Carolina Entertainment

THE MARK CONSISTS OF STANDARD CHARACTERS WITHOUT CLAIM TO ANY PARTICULAR FONT, STYLE, SIZE, OR COLOR.

NO CLAIM IS MADE TO THE EXCLUSIVE RIGHT TO USE "ENTERTAINMENT", APART FROM THE MARK AS SHOWN.

SEC. 2(F).

FOR DISC JOCKEYS FOR PARTIES AND SPECIAL EVENTS (U.S. CLS. 100, 101 AND 107).

FIRST USE 10-1-2002; IN COMMERCE 10-1-2002.

PAM WILLIS, EXAMINING ATTORNEY

SN 85-130,124. NORRIS, RAY, ARNOLD, MO. FILED 9-15-2010.

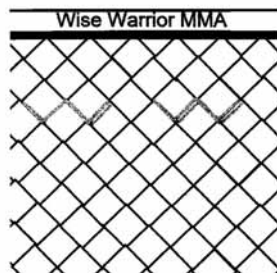

NO CLAIM IS MADE TO THE EXCLUSIVE RIGHT TO USE "MMA", APART FROM THE MARK AS SHOWN.

THE STIPPLING IS FOR SHADING PURPOSES ONLY.

THE MARK CONSISTS OF A FENCE WITH A PADDED RAIL AT THE TOP AS THE MAIN PART OF THE LOGO. ON THE PADDING AT THE TOP IT READS "WISE WARRIOR MMA". TWO LARGE CASE "W"'S ARE PART OF THE FENCING. THEY ARE LOCATED IN THE MIDDLE OF THE LOGO.

FOR INSTRUCTION IN THE FIELD OF MIXED MARTIAL ARTS (U.S. CLS. 100, 101 AND 107).

FIRST USE 6-15-2010; IN COMMERCE 7-15-2010.

MARTHA SANTOMARTINO, EXAMINING ATTORNEY

SN 85-131,651. IMAGINARY LINES, INC., SAN DIEGO, CA. FILED 9-16-2010.

SALLY RIDE SCIENCE ACADEMY

THE MARK CONSISTS OF STANDARD CHARACTERS WITHOUT CLAIM TO ANY PARTICULAR FONT, STYLE, SIZE, OR COLOR.

OWNER OF U.S. REG. NO. 3,215,455.

NO CLAIM IS MADE TO THE EXCLUSIVE RIGHT TO USE "SCIENCE ACADEMY", APART FROM THE MARK AS SHOWN.

THE NAME "SALLY RIDE" IDENTIFIES A LIVING INDIVIDUAL WHOSE CONSENT IS OF RECORD.

FOR EDUCATIONAL SERVICES, NAMELY, ORGANIZING AND CONDUCTING SCIENCE PROGRAMS IN THE NATURE OF WORKSHOPS AND SEMINARS IN THE FIELD OF SCIENCE AND ENGINEERING; EDUCATIONAL SERVICES, NAMELY, CONDUCTING PROGRAMS IN THE FIELD OF SCIENCE AND ENGINEERING; EDUCATIONAL SERVICES, NAMELY, CONTINUING EDUCATION COURSES, WORKSHOPS, AND CONFERENCES FOR TEACHERS AND EDUCATION PROFESSIONALS (U.S. CLS. 100, 101 AND 107).

FIRST USE 3-23-2009; IN COMMERCE 3-23-2009.

TARA PATE, EXAMINING ATTORNEY

CLASS 41—(Continued).

SN 85-133,932. DISCOVERY COMMUNICATIONS, LLC, SILVER SPRING, MD. FILED 9-20-2010.

LITTLE PEOPLE, BIG WORLD

THE MARK CONSISTS OF STANDARD CHARACTERS WITHOUT CLAIM TO ANY PARTICULAR FONT, STYLE, SIZE, OR COLOR.

NO CLAIM IS MADE TO THE EXCLUSIVE RIGHT TO USE "LITTLE PEOPLE", APART FROM THE MARK AS SHOWN.

FOR ENTERTAINMENT AND EDUCATIONAL SERVICES IN THE NATURE OF TELEVISION AND MULTIMEDIA PROGRAM SERIES FEATURING SUBJECTS OF GENERAL HUMAN INTEREST DISTRIBUTED VIA VARIOUS PLATFORMS ACROSS MULTIPLE FORMS OF TRANSMISSION MEDIA; PROVIDING ENTERTAINMENT INFORMATION TO OTHERS VIA A GLOBAL COMPUTER NETWORK (U.S. CLS. 100, 101 AND 107).

FIRST USE 3-4-2006; IN COMMERCE 3-4-2006.

TIMOTHY FINNEGAN, EXAMINING ATTORNEY

SN 85-133,988. NADINE'S WORLD LLC, ANAHEIM HILLS, CA. FILED 9-20-2010.

DANCE WITH YOUR TOOLS

THE MARK CONSISTS OF STANDARD CHARACTERS WITHOUT CLAIM TO ANY PARTICULAR FONT, STYLE, SIZE, OR COLOR.

FOR EDUCATIONAL SERVICES IN THE FIELD OF HAIR STYLING, NAMELY, TRAINING OF HAIR STYLISTS (U.S. CLS. 100, 101 AND 107).

EUGENIA MARTIN, EXAMINING ATTORNEY

SN 85-140,523. HARALSON, J. DAVIL, LAWRENCEVILLE, GA. FILED 9-29-2010.

NOW THAT'S A GOOD LOOK

THE MARK CONSISTS OF STANDARD CHARACTERS WITHOUT CLAIM TO ANY PARTICULAR FONT, STYLE, SIZE, OR COLOR.

FOR MULTIMEDIA PRODUCTION SERVICES, NAMELY, VIDEO PRODUCTION IN THE FIELD OF ART, ENTERTAINMENT, AND CULTURE (U.S. CLS. 100, 101 AND 107).

ANDREA HACK, EXAMINING ATTORNEY

CLASS 41—(Continued).

SN 85-140,525. UNCAGED ENTERTAINMENT LLC, JACKSON, MS. FILED 9-29-2010.

2D UNCAGED MUSIC GROUP

THE MARK CONSISTS OF STANDARD CHARACTERS WITHOUT CLAIM TO ANY PARTICULAR FONT, STYLE, SIZE, OR COLOR.

NO CLAIM IS MADE TO THE EXCLUSIVE RIGHT TO USE "MUSIC GROUP", APART FROM THE MARK AS SHOWN.

FOR ENTERTAINMENT SERVICES IN THE NATURE OF RECORDING, PRODUCTION AND POST-PRODUCTION SERVICES IN THE FIELD OF MUSIC (U.S. CLS. 100, 101 AND 107).

ANDREA HACK, EXAMINING ATTORNEY

SN 85-140,962. NOVELLUS HEALTHCARE COMMUNICATIONS, LLC, MONROE TOWNSHIP, NJ. FILED 9-29-2010.



NO CLAIM IS MADE TO THE EXCLUSIVE RIGHT TO USE "PEDIATRIC NP/PA", APART FROM THE MARK AS SHOWN.

THE MARK CONSISTS OF THE WORDS "PEDIATRIC NP/PA" WHERE THERE IS A CHILDREN'S CRAYON-LIKE DRAWING OF A SUN BETWEEN THE WORDS "PEDIATRIC AND NP/PA". SUPERIMPOSED IN FRONT OF THE SUN IS AN IMPRESSIONISTIC RENDERING OF A BOY AND A GIRL WITH THEIR ARMS UP IN THE AIR. THERE IS A STRAIGHT HORIZONTAL LINE UNDERSCORING THE PHRASE "PEDIATRIC NP/PA". UNDERNEATH THE HORIZONTAL LINE IS THE TAG-LINE, ON TWO SEPARATE LINES "THE OFFICIAL NEWSPAPER FOR THE PEDIATRIC/ADOLESCENT NURSE AND ADVANCED PRACTITIONER".

FOR EDUCATIONAL SERVICES, NAMELY, PROVIDING CONTINUING EDUCATION COURSES AND EXAMS IN THE FIELDS OF PEDIATRICS AND NURSING VIA A GLOBAL COMPUTER INFORMATION NETWORK AND VIA PRINT MEDIA; PROVIDING INFORMATION IN THE FIELD OF PEDIATRIC NURSING EDUCATION VIA THE INTERNET (U.S. CLS. 100, 101 AND 107).

DANNEAN HETZEL, EXAMINING ATTORNEY

CLASS 41—(Continued).

SN 85-141,809. CHENG & TSUI COMPANY, INC., BOSTON, MA. FILED 9-30-2010.



CHENG & TSUI

OWNER OF U.S. REG. NO. 2,093,109.
THE MARK CONSISTS OF A FAN IMAGE IN RED, AND BELOW IT APPEARS THE WORDING "CHENG & TSUI" IN BLACK.

THE WORDING "CHENG & TSUI" HAS NO MEANING IN A FOREIGN LANGUAGE.

FOR BOOK PUBLISHING; PUBLISHING OF BOOKS, E-BOOKS, AUDIO BOOKS, MUSIC AND ILLUSTRATIONS (U.S. CLS. 100, 101 AND 107).

FIRST USE 11-1-1980; IN COMMERCE 11-1-1980.
NAAKWAMA ANKRAH, EXAMINING ATTORNEY

CLASS 41—(Continued).

SN 85-142,327. ATTORNEYS' TITLE INSURANCE FUND, ORLANDO, FL. FILED 9-30-2010.

THE FUND ASSEMBLY

THE MARK CONSISTS OF STANDARD CHARACTERS WITHOUT CLAIM TO ANY PARTICULAR FONT, STYLE, SIZE, OR COLOR.

OWNER OF U.S. REG. NO. 1,613,190.

NO CLAIM IS MADE TO THE EXCLUSIVE RIGHT TO USE "ASSEMBLY", APART FROM THE MARK AS SHOWN.

FOR CONTINUING EDUCATION SERVICES, NAMELY, PROVIDING CONTINUING PROFESSIONAL EDUCATION SEMINARS IN THE FIELDS OF TITLE INSURANCE UNDERWRITING SERVICES, REAL ESTATE TRANSACTION SERVICES, REAL ESTATE CLOSING SERVICES, AND REAL ESTATE LAW SERVICES, AND DISTRIBUTION OF COURSE MATERIALS IN CONNECTION THEREWITH (U.S. CLS. 100, 101 AND 107).

FIRST USE 0-0-1964; IN COMMERCE 0-0-1997.
MICHAEL ENGEL, EXAMINING ATTORNEY

SN 85-142,674. DR. JULIA D. ROSS, MARTINSBURG, WV. FILED 9-30-2010.

SN 85-141,957. ATTORNEYS' TITLE INSURANCE FUND, ORLANDO, FL. FILED 9-30-2010.

CREATORPRENEUR

THE FUND

THE MARK CONSISTS OF STANDARD CHARACTERS WITHOUT CLAIM TO ANY PARTICULAR FONT, STYLE, SIZE, OR COLOR.

OWNER OF U.S. REG. NO. 1,613,190.

FOR EDUCATION SERVICES, NAMELY, PROVIDING LIVE AND ON-LINE CONTINUING PROFESSIONAL EDUCATION SEMINARS IN THE FIELDS OF TITLE INSURANCE UNDERWRITING SERVICES, REAL ESTATE TRANSACTION SERVICES, REAL ESTATE CLOSING SERVICES, AND REAL ESTATE LAW SERVICES (U.S. CLS. 100, 101 AND 107).

FIRST USE 0-0-1964; IN COMMERCE 0-0-1997.
MICHAEL ENGEL, EXAMINING ATTORNEY

THE MARK CONSISTS OF STANDARD CHARACTERS WITHOUT CLAIM TO ANY PARTICULAR FONT, STYLE, SIZE, OR COLOR.

FOR BUSINESS EDUCATION AND TRAINING SERVICES, NAMELY, CONDUCTING TRAINING IN THE FIELDS OF BUSINESS MANAGEMENT AND PERSONAL DEVELOPMENT TO HELP OTHERS INTEGRATE 19TH CENTURY SKILLS OF ENTERPRISE, MASTERY, SELF-RELIANCE, AND RESOLUTENESS INTO THE 21ST CENTURY ECONOMY AND DISTRIBUTION OF COURSE MATERIALS IN CONNECTION THEREWITH; PROVIDING A WEBSITE FEATURING BUSINESS EDUCATION AND TRAINING SERVICES, NAMELY, CONDUCTING TRAINING IN THE FIELDS OF BUSINESS MANAGEMENT AND PERSONAL DEVELOPMENT TO HELP OTHERS INTEGRATE 19TH CENTURY SKILLS OF ENTERPRISE, MASTERY, SELF-RELIANCE, AND RESOLUTENESS INTO THE 21ST CENTURY ECONOMY AND DISTRIBUTION OF COURSE MATERIALS IN CONNECTION THEREWITH (U.S. CLS. 100, 101 AND 107).

KAPIL BHANOT, EXAMINING ATTORNEY

CLASS 41—(Continued).

SN 85-144,721. WOOD, TRAVIS, NEW YORK, NY. FILED 10-4-2010.



NO CLAIM IS MADE TO THE EXCLUSIVE RIGHT TO USE "DATING MASTERY COURSE", APART FROM THE MARK AS SHOWN.

THE MARK CONSISTS OF A DIAMOND WITH THE STYLIZED TEXT "DATING MASTERY COURSE".

FOR LIFE COACHING SERVICES IN THE FIELD OF DATING, RELATIONSHIPS, AND BUSINESS (U.S. CLS. 100, 101 AND 107).

KIM MONINGHOFF, EXAMINING ATTORNEY

SN 85-145,362. MAGEE TV INC., TORONTO, ONTARIO, CANADA, FILED 10-5-2010.

THE SMART WOMAN SURVIVAL
GUIDE

THE MARK CONSISTS OF STANDARD CHARACTERS WITHOUT CLAIM TO ANY PARTICULAR FONT, STYLE, SIZE, OR COLOR.

NO CLAIM IS MADE TO THE EXCLUSIVE RIGHT TO USE "WOMAN" AND "GUIDE", APART FROM THE MARK AS SHOWN.

FOR ENTERTAINMENT IN THE NATURE OF AN ONGOING TELEVISION PROGRAM IN THE FIELD OF LIFESTYLE AND WOMEN'S ISSUES (U.S. CLS. 100, 101 AND 107).

HENRY S. ZAK, EXAMINING ATTORNEY

SN 85-145,435. ANSWERS CORPORATION, NEW YORK CITY, NY. FILED 10-5-2010.

BLUFR

THE MARK CONSISTS OF STANDARD CHARACTERS WITHOUT CLAIM TO ANY PARTICULAR FONT, STYLE, SIZE, OR COLOR.

FOR ENTERTAINMENT IN THE NATURE OF ONGOING TELEVISION PROGRAMS IN THE FIELD OF PUZZLES AND GAMES; ENTERTAINMENT SERVICES, NAMELY, PROVIDING ON-LINE COMPUTER GAMES; PROVIDING A COMPUTER GAME THAT MAY BE ACCESSED NETWORK-WIDE BY NETWORK USERS (U.S. CLS. 100, 101 AND 107).

EDWARD FENNESSY, EXAMINING ATTORNEY

CLASS 41—(Continued).

SN 85-146,502. THE STATE FAIR OF VIRGINIA, INC., MECHANICSVILLE, VA. FILED 10-6-2010.



OWNER OF U.S. REG. NO. 3,871,288.

NO CLAIM IS MADE TO THE EXCLUSIVE RIGHT TO USE "HIGHLAND GAMES & CELTIC FESTIVAL", APART FROM THE MARK AS SHOWN.

THE MARK CONSISTS OF CIRCLE WITH THE WORDS "MEADOW HIGHLAND GAMES" INSIDE OF THE TOP OF THE CIRCLE, AND THE WORDS "& CELTIC FESTIVAL" INSIDE THE BOTTOM OF THE CIRCLE, BOTH SURROUNDING A WHITE CIRCULAR DESIGN WITH A BLACK BACKGROUND.

FOR ENTERTAINMENT IN THE NATURE OF GAMES REFLECTING SCOTTISH CULTURE AND HISTORY, NAMELY, CABER TOSS, STONE THROW, SCOTTISH HAMMER, 28 LBS. AND 56 LBS. WEIGHTS FOR DISTANCE, WEIGHT FOR HEIGHT, SHEAF TOSS, PIPING, DRUMMING, HIGHLAND DANCE, SCOTTISH AND IRISH FIDDLE, AND HARP COMPETITIONS (U.S. CLS. 100, 101 AND 107).

FIRST USE 7-1-2009; IN COMMERCE 7-1-2009.

CAROLYN CATALDO, EXAMINING ATTORNEY

SN 85-147,059. MILLER, SALLY, MILLTOWN, NJ. FILED 10-7-2010.



NO CLAIM IS MADE TO THE EXCLUSIVE RIGHT TO USE "FASHION ACADEMY INC.", APART FROM THE MARK AS SHOWN.

THE COLOR(S) BLUE AND GREEN IS/ARE CLAIMED AS A FEATURE OF THE MARK.

THE MARK CONSISTS OF THE WORDS "FASHION ACADEMY INC." WITH THE LETTERS "FASHI" "N" IN THE COLOR GREEN, THE LETTER "O" SHAPED LIKE A BUTTON IN THE COLOR BLUE WITH A BLUE SHADOW, AND THE WORDS "ACADEMY INC." IN BLUE.

FOR WORKSHOPS, CLASSES AND SEMINARS IN THE FIELD OF FASHION DESIGN (U.S. CLS. 100, 101 AND 107).

FIRST USE 4-8-2010; IN COMMERCE 4-8-2010.

PAUL E. FAHRENKOPF, EXAMINING ATTORNEY

CLASS 41—(Continued).

SN 85-147,424. SMITH, JIMMY LEE, JACKSON, MS. FILED 10-7-2010.

TEAM 82

THE MARK CONSISTS OF STANDARD CHARACTERS WITHOUT CLAIM TO ANY PARTICULAR FONT, STYLE, SIZE, OR COLOR.

FOR PHYSICAL FITNESS CONSULTATION; PHYSICAL FITNESS INSTRUCTION; TRAINING SERVICES IN THE FIELD OF PHYSICAL FITNESS; ELITE ATHLETE TRAINING SERVICE (U.S. CLS. 100, 101 AND 107).
KIMBERLY FRYE, EXAMINING ATTORNEY

SN 85-147,446. SMITH, JIMMY LEE, JACKSON, MS. FILED 10-7-2010.



THE MARK CONSISTS OF THE PHRASE "TEAM82" SLANTED FROM LEFT TO RIGHT WITH A "T" THAT IS LARGER THAN THE REST OF THE LETTERS IN THE WORD "TEAM". WITH THE EXCEPTION OF THE LETTER "T", "TEAM82" IS UNDERLINED WITH A STRAIGHT BAR. THE UNDERLINED PHRASE "TEAM82" OVERLAYS THE SHAPE OF A STAR WHICH ALSO SLANTS FROM LEFT TO RIGHT.

FOR PHYSICAL FITNESS CONSULTATION; PHYSICAL FITNESS INSTRUCTION; TRAINING SERVICES IN THE FIELD OF PHYSICAL FITNESS; ELITE ATHLETE TRAINING SERVICES (U.S. CLS. 100, 101 AND 107).
KIMBERLY FRYE, EXAMINING ATTORNEY

SN 85-147,455. DART INDUSTRIES INC., ORLANDO, FL. FILED 10-7-2010.

**TUPPERWARE BRANDS
CONFIDENCE**

THE MARK CONSISTS OF STANDARD CHARACTERS WITHOUT CLAIM TO ANY PARTICULAR FONT, STYLE, SIZE, OR COLOR.

OWNER OF U.S. REG. NOS. 633,394, 3,690,375 AND OTHERS.

NO CLAIM IS MADE TO THE EXCLUSIVE RIGHT TO USE "BRANDS", APART FROM THE MARK AS SHOWN.

FOR ONLINE ELECTRONIC NEWSLETTERS IN THE FIELDS OF SOCIAL RESPONSIBILITY, CHARITABLE ACTIVITIES AND CHARITABLE ORGANIZATIONS (U.S. CLS. 100, 101 AND 107).

FIRST USE 9-30-2010; IN COMMERCE 9-30-2010.
DEBRA LEE, EXAMINING ATTORNEY

CLASS 41—(Continued).

SN 85-148,057. SEABROOKS, TARREZ, MACCLENNY, FL. FILED 10-8-2010.

DOING ME ENTERTAINMENT

THE MARK CONSISTS OF STANDARD CHARACTERS WITHOUT CLAIM TO ANY PARTICULAR FONT, STYLE, SIZE, OR COLOR.

NO CLAIM IS MADE TO THE EXCLUSIVE RIGHT TO USE "ENTERTAINMENT", APART FROM THE MARK AS SHOWN.

FOR RECORD LABEL SERVICES, NAMELY, MUSIC PRODUCTION AND PUBLISHING SERVICES, AND ORGANIZING EVENTS FEATURING LIVE MUSICAL PERFORMANCES; ENTERTAINMENT IN THE NATURE OF VISUAL AND AUDIO PERFORMANCES BY A GOSPEL SINGER AND MUSIC MINISTRY; LIVE PERFORMANCES BY A GOSPEL SINGER AND MUSIC MINISTRY (U.S. CLS. 100, 101 AND 107).

FIRST USE 8-21-2009; IN COMMERCE 10-12-2009.
DAVID TOOLEY, EXAMINING ATTORNEY

SN 85-150,789. FRATERNAL ORDER OF POLICE, NASHVILLE, TN. FILED 10-12-2010.



OWNER OF U.S. REG. NOS. 568,983, 1,527,776 AND OTHERS.

NO CLAIM IS MADE TO THE EXCLUSIVE RIGHT TO USE "KIDS", APART FROM THE MARK AS SHOWN.

THE COLOR(S) BLUE, GOLD, BLACK, ORANGE, RED AND GREEN IS/ARE CLAIMED AS A FEATURE OF THE MARK.

THE MARK CONSISTS OF THE WORD "COPS" IN BLUE, WITH THE "O" REPRESENTED BY THE FOP STAR IN BLUE WITH FIVE GOLD POINTS OVER A GOLD CIRCLE, WITH THE LETTERS "FOP" AND "JUS FIDUS LIBERTATUM" IN GOLD, AND A CREST OR SHIELD INSIDE IN GOLD AND BLACK, THE WORD "AND" IN BLUE, AND THE WORD "KIDS" IN CROOKED LETTERS WITH AN ORANGE "K", BLUE "I", RED "D" AND GREEN "S".

THE ENGLISH TRANSLATION OF "JUS", "FIDUS", AND "LIBERTATUM" IN THE MARK IS RESPECTIVELY, "LAW", "FAITH", AND "LIBERTY".

FOR CHARITABLE SERVICES, NAMELY, PROVIDING SCHOOL SUPPLIES TO CHILDREN IN NEED; CHARITABLE SERVICES, NAMELY, PROVIDING TOYS TO NEEDY CHILDREN (U.S. CLS. 100, 101 AND 107).
ALICE BENMAMAN, EXAMINING ATTORNEY

CLASS 41—(Continued).

SN 85-151,148. OZERSKY, JOSHUA, BROOKLYN, NY.
FILED 10-12-2010.

Meatopia

THE MARK CONSISTS OF STANDARD CHARACTERS WITHOUT CLAIM TO ANY PARTICULAR FONT, STYLE, SIZE, OR COLOR.

FOR CONDUCTING ENTERTAINMENT EXHIBITIONS IN THE NATURE OF FOOD FESTIVALS FEATURING FOOD TASTINGS, CULINARY DEMONSTRATIONS, COOKING COMPETITIONS AND LIVE MUSICAL PERFORMANCES (U.S. CLS. 100, 101 AND 107).

FIRST USE 7-1-2003; IN COMMERCE 7-1-2003.
DAWN HAN, EXAMINING ATTORNEY

SN 85-151,468. HTV MEDIA GROUP, LLC, WEST PALM BEACH, FL. FILED 10-13-2010.

CELEB GPS

THE MARK CONSISTS OF STANDARD CHARACTERS WITHOUT CLAIM TO ANY PARTICULAR FONT, STYLE, SIZE, OR COLOR.

NO CLAIM IS MADE TO THE EXCLUSIVE RIGHT TO USE "CELEB", APART FROM THE MARK AS SHOWN.

FOR ENTERTAINMENT SERVICES IN THE NATURE OF A TELEVISION SERIES IN THE FIELD OF CELEBRITY ENTERTAINMENT NEWS; ENTERTAINMENT SERVICES, NAMELY, PROVIDING A WEBSITE FEATURING CELEBRITY ENTERTAINMENT NEWS AND INFORMATION, CELEBRITY INTERVIEWS IN THE FIELD OF MOVIES, MUSIC, TELEVISION, AND SPORTS; ENTERTAINMENT SERVICES, NAMELY, PROVIDING NON-DOWNLOADABLE VIDEOS, FILM CLIPS, PHOTOGRAPHS, AND OTHER MULTIMEDIA MATERIALS IN THE FIELD OF MOVIES, MUSIC, TELEVISION AND SPORTS FOR ENTERTAINMENT PURPOSES (U.S. CLS. 100, 101 AND 107).

ELIZABETH HUGHITT, EXAMINING ATTORNEY

SN 85-152,078. PROVO, INC., DBA RVR NECKWEAR, NEW YORK, NY. FILED 10-13-2010.

THE MARK CONSISTS OF A STYLIZED BACKWARDS LETTER "R", A STYLIZED LETTER "V", AND A STYLIZED BACKWARDS "R".

FOR BOOK PUBLISHING SERVICES IN THE FIELDS OF FASHION, STYLE, AND CULTURE FOR MEN (U.S. CLS. 100, 101 AND 107).

FIRST USE 6-29-2010; IN COMMERCE 6-29-2010.
JANICE L. MCMORROW, EXAMINING ATTORNEY

CLASS 41—(Continued).

SN 85-152,961. LEITE'S CULINARIA, INC., NEW YORK, NY.
FILED 10-14-2010.

WEEKEND PROJECT

THE MARK CONSISTS OF STANDARD CHARACTERS WITHOUT CLAIM TO ANY PARTICULAR FONT, STYLE, SIZE, OR COLOR.

FOR PROVIDING ON-LINE, NON-DOWNLOADABLE PUBLICATIONS IN THE NATURE OF NEWSLETTERS IN THE FIELD OF COOKING AND RECIPES (U.S. CLS. 100, 101 AND 107).

FIRST USE 1-4-2010; IN COMMERCE 1-4-2010.
RONALD AIKENS, EXAMINING ATTORNEY

SN 85-154,366. ATTORNEYS' TITLE INSURANCE FUND, ORLANDO, FL. FILED 10-16-2010.

FUND ALERT

THE MARK CONSISTS OF STANDARD CHARACTERS WITHOUT CLAIM TO ANY PARTICULAR FONT, STYLE, SIZE, OR COLOR.

OWNER OF U.S. REG. NOS. 1,613,190 AND 2,252,081.

NO CLAIM IS MADE TO THE EXCLUSIVE RIGHT TO USE "ALERT", APART FROM THE MARK AS SHOWN.

FOR PROVIDING ON-LINE NEWSLETTERS IN THE FIELD OF INSURANCE UNDERWRITING (U.S. CLS. 100, 101 AND 107).

FIRST USE 4-0-2003; IN COMMERCE 4-0-2003.
BARBARA GAYNOR, EXAMINING ATTORNEY

SN 85-154,699. BROTHERHOOD INSTRUCTOR'S LLC, WASHINGTONVILLE, NY. FILED 10-18-2010.

WE TALK TO YOU, NOT AT YOU

THE MARK CONSISTS OF STANDARD CHARACTERS WITHOUT CLAIM TO ANY PARTICULAR FONT, STYLE, SIZE, OR COLOR.

FOR EDUCATIONAL SERVICES, NAMELY, CONDUCTING LECTURES, DISCUSSIONS, FIELD TRAINING AND ON-LINE TUTORIALS IN THE FIELD OF FIREFIGHTING OPERATIONS (U.S. CLS. 100, 101 AND 107).

FIRST USE 2-28-2006; IN COMMERCE 2-28-2008.
LOURDES AYALA, EXAMINING ATTORNEY

CLASS 41—(Continued).

SN 85-154,925. BROTHERHOOD INSTRUCTOR'S LLC, WASHINGTONVILLE, NY. FILED 10-18-2010.



NO CLAIM IS MADE TO THE EXCLUSIVE RIGHT TO USE "BROTHERHOOD INSTRUCTORS LLC AND EST. 2006", APART FROM THE MARK AS SHOWN.

THE COLOR(S) BLACK, YELLOW, SILVER AND DARK GREY IS/ARE CLAIMED AS A FEATURE OF THE MARK.

THE MARK CONSISTS OF THE WORDING "BRINGING BACK THE BASICS TO TODAY'S FIRE SERVICE BROTHERHOOD INSTRUCTORS, LLC "WE TALK TO YOU, NOT AT YOU" EST. 2006." THE WORDING "BRINGING BACK THE BASICS TO TODAY'S FIRE SERVICE" IS IN BLACK, THE WORDING "BROTHERHOOD INSTRUCTORS, LLC "WE TALK TO YOU, NOT AT YOU" EST. 2006" IS IN YELLOW. THE WORDING IS FEATURED INSIDE OF A CIRCLE PATCH WITH A FIREFIGHTING HOSE IN YELLOW CIRCLING THE OUTSIDE EDGE OF THE PATCH AND A FIREFIGHTING NOZZLE IN SILVER, WITH THE WORDS, "BRINGING BACK THE BASICS TO TODAY'S FIRE SERVICE" WITHIN THE HOSE; THE INTERIOR OF THE PATCH IS BLACK WITH A CENTER PIECE CONTAINING FIREFIGHTING TOOLS COMPRISING OF A POWER SAW, AXE, PICK AND PRY BAR IN YELLOW, BLACK, SILVER AND DARK GREY; THE INTERIOR OF THE PATCH CONTAINS THE WORDS, "BROTHERHOOD INSTRUCTORS, LLC" IN YELLOW, "WE TALK TO YOU, NOT AT YOU" IN YELLOW AND "EST. 2006" IN YELLOW.

FOR EDUCATIONAL SERVICES, NAMELY, CONDUCTING LECTURES, DISCUSSIONS, FIELD TRAINING AND ON-LINE TUTORIALS IN THE FIELD OF FIREFIGHTING OPERATIONS (U.S. CLS. 100, 101 AND 107).

FIRST USE 2-26-2006; IN COMMERCE 2-28-2008.
LOURDES AYALA, EXAMINING ATTORNEY

CLASS 41—(Continued).

SN 85-157,058. PARR, RYAN MATTHEW, DBA CONSCIOUS MUSIC, AUSTIN, TX. FILED 10-20-2010.



NO CLAIM IS MADE TO THE EXCLUSIVE RIGHT TO USE "MUSIC", APART FROM THE MARK AS SHOWN.

THE MARK CONSISTS OF THE GLOBE OF THE EARTH IN THE MIDDLE, HEADPHONES AROUND THE GLOBE, WITH CONSCIOUS MUSIC RIGHT BELOW. ON THE OUTSIDE OF THE HEADPHONES THERE ARE SOUNDWAVES COMING FROM THE HEADPHONES.

FOR COMPOSITION OF MUSIC FOR OTHERS; ENTERTAINMENT SERVICES BY A MUSICAL ARTIST AND PRODUCER, NAMELY, MUSICAL COMPOSITION FOR OTHERS AND PRODUCTION OF MUSICAL SOUND RECORDINGS; ENTERTAINMENT SERVICES IN THE NATURE OF LIVE MUSICAL PERFORMANCES; ENTERTAINMENT SERVICES IN THE NATURE OF RECORDING, PRODUCTION AND POST-PRODUCTION SERVICES IN THE FIELD OF MUSIC; ENTERTAINMENT SERVICES, NAMELY, PROVIDING A WEB SITE FEATURING NON-DOWNLOADABLE MUSICAL PERFORMANCES, MUSICAL VIDEOS, RELATED FILM CLIPS, PHOTOGRAPHS, AND OTHER MULTIMEDIA MATERIALS FEATURING MUSIC; ENTERTAINMENT, NAMELY, LIVE MUSIC CONCERTS; MUSIC COMPOSITION AND TRANSCRIPTION FOR OTHERS; MUSIC COMPOSITION FOR OTHERS; MUSIC PRODUCTION SERVICES; PRODUCTION OF MUSICAL SOUND RECORDING (U.S. CLS. 100, 101 AND 107).

ROBERT STRUCK, EXAMINING ATTORNEY

SN 85-158,192. MINDAVATION INC, BAXTER, MN. FILED 10-21-2010.

THE MARK CONSISTS OF THE STYLIZED WORD "MINDAVATION" WITH A CURVED LINE OVER THE "V", UNDERLINING UNDER THE LETTER "T" AND "D" AND OVERLINING OVER THE LETTER "O" AND AN OVAL OVER THE LETTER "M".

FOR EDUCATIONAL SERVICES, NAMELY, CONDUCTING WORKSHOPS AND PRESENTATIONS IN THE FIELDS OF TEAM BUILDING, PROJECT MANAGEMENT, PERSONAL MOTIVATION AND TEAMWORK AND DISTRIBUTION OF TRAINING MATERIALS IN CONNECTION THEREWITH (U.S. CLS. 100, 101 AND 107).

FIRST USE 5-1-2000; IN COMMERCE 5-1-2000.
KIMBERLY FRYE, EXAMINING ATTORNEY

CLASS 41—(Continued).

SN 85-161,238. ERIKA'S LIGHTHOUSE: A BEACON OF HOPE FOR ADOLESCENT DEPRESSION, WINNETKA, IL. FILED 10-26-2010.

ERIKA'S LIGHTHOUSE

THE MARK CONSISTS OF STANDARD CHARACTERS WITHOUT CLAIM TO ANY PARTICULAR FONT, STYLE, SIZE, OR COLOR.

FOR EDUCATIONAL SERVICES, NAMELY, CONDUCTING CLASSES, SEMINARS, WORKSHOPS, PROGRAMS, AND PANEL DISCUSSIONS RELATED TO CHILDHOOD AND ADOLESCENT DEPRESSION, AND DISTRIBUTION OF COURSE AND EDUCATIONAL MATERIALS IN PRINTED AND ELECTRONIC FORM IN CONNECTION THEREWITH (U.S. CLS. 100, 101 AND 107).

FIRST USE 6-1-2004; IN COMMERCE 6-1-2004.

PAUL E. FAHRENKOPF, EXAMINING ATTORNEY

CLASS 41—(Continued).

SN 85-163,707. POST-NEWSWEEK STATIONS, FLORIDA, INC., JACKSONVILLE, FL. FILED 10-28-2010.

NEWS4JAX

THE MARK CONSISTS OF STANDARD CHARACTERS WITHOUT CLAIM TO ANY PARTICULAR FONT, STYLE, SIZE, OR COLOR.

SEC. 2(F).

FOR PROVIDING AN ONLINE NEWSPAPER FEATURING INFORMATION IN THE FIELDS OF NEWS, POLITICS, WEATHER, SPORTS, BUSINESS, HEALTH, REAL ESTATE, ENTERTAINMENT, TRAVEL, AND CLASSIFIED ADVERTISING (U.S. CLS. 100, 101 AND 107).

FIRST USE 6-5-2000; IN COMMERCE 6-5-2000.

MICHELLE DUBOIS, EXAMINING ATTORNEY

SN 85-163,122. CHINA ORIENTAL PERFORMING ARTS GROUP, BEIJING 100027, CHINA, FILED 10-27-2010.



NO CLAIM IS MADE TO THE EXCLUSIVE RIGHT TO USE "CHINA ORIENTAL PERFORMING ARTS GROUP" OR THE NON-LATIN CHARACTERS THAT TRANSLITERATE TO ZHONG, GUÓ, DONG, FANG, YAN, YÌ, JÌ, TUAN, APART FROM THE MARK AS SHOWN.

THE MARK CONSISTS OF CHINESE CHARACTERS ABOVE THE WORDING "CHINA ORIENTAL PERFORMING ARTS GROUP" WITH THE CHARACTERS AND WORDING TO THE RIGHT OF A SWIRL SHAPED DESIGN.

THE NON-LATIN CHARACTERS IN THE MARK TRANSLITERATE TO ZHONG, GUÓ, DONG, FANG, YAN, YÌ, JÌ, TUAN AND THIS MEANS "CHINA ORIENTAL PERFORMING ARTS GROUP" IN ENGLISH.

FOR ENTERTAINMENT SERVICES IN THE NATURE OF THEATER PRODUCTIONS; ENTERTAINER SERVICES, NAMELY, LIVE PERFORMANCES OF THEATRICAL PRODUCTIONS; PRESENTATION OF LIVE SHOW PERFORMANCES; ENTERTAINMENT, NAMELY, PRODUCTION OF THEATRE SHOWS (U.S. CLS. 100, 101 AND 107).

JAMES LOVELACE, EXAMINING ATTORNEY

SN 85-164,164. INTERNET SPORT GAMES ASSOCIATES, LLC, HOLMDEL, NJ. FILED 10-28-2010.



NO CLAIM IS MADE TO THE EXCLUSIVE RIGHT TO USE "SCHOLAR GAMERS.COM", APART FROM THE MARK AS SHOWN.

THE COLOR(S) DARK BLUE, WHITE, GREY AND YELLOW IS/ARE CLAIMED AS A FEATURE OF THE MARK.

THE MARK CONSISTS OF THE WORDING "SCHOLAR GAMERS.COM" IN WHITE CAPITAL LETTERS. BEHIND THE WORDING THERE APPEARS A STYLIZED YELLOW SHIELD WITH A GREY GRADUATION CAP OUTLINED IN DARK BLUE. THE BACKGROUND IS DARK BLUE.

FOR PROVIDING A WEBSITE THROUGH WHICH PEOPLE CAN PARTICIPATE IN TOURNAMENTS AND COMPETITIONS, NAMELY, ENTERTAINMENT SERVICES IN THE NATURE OF PROVIDING ONLINE COMPUTER AND VIDEO GAMES, AND PROVIDING A WEBSITE THROUGH WHICH PEOPLE LOCATE INFORMATION ABOUT TOURNAMENTS, EVENTS AND COMPETITIONS IN THE VIDEO GAME FIELD (U.S. CLS. 100, 101 AND 107).

FIRST USE 8-28-2010; IN COMMERCE 8-28-2010.

SARA BENJAMIN, EXAMINING ATTORNEY

CLASS 41—(Continued).

SN 85-165,075. CETRUS - CENTRO DE ENSINO EM TOMOGRAFIA RESSONANCIA E ULTRA SONOGRAFIA LTDA, SAO PAULO, BRAZIL, FILED 10-29-2010.



NO CLAIM IS MADE TO THE EXCLUSIVE RIGHT TO USE "SCHOOL", APART FROM THE MARK AS SHOWN.

THE MARK CONSISTS OF THE WORDING "SONO SCHOOL" PLACED SO THAT "SONO" APPEARS ABOVE "SCHOOL", IN STYLIZED LETTERS, OVER A SQUARE POSITIONED SIDWAYS. A CURVED LINE CROSSES THE SQUARE FROM SIDE TO SIDE RIGHT IN THE MIDDLE.

THE WORDING "SONO" HAS NO MEANING IN A FOREIGN LANGUAGE.

FOR TEACHING, TRAINING, TUTORING AND COURSES OF INSTRUCTION IN THE FIELD OF HEALTHCARE FOR MEDICAL TECHNICIANS, PARAMEDICS, AND HEALTHCARE PROFESSIONALS (U.S. CLS. 100, 101 AND 107).

APRIL HESIK, EXAMINING ATTORNEY

CLASS 41—(Continued).

SN 85-170,171. INTERNATIONAL PLANT NUTRITION INSTITUTE, NORCROSS, GA. FILED 11-5-2010.



NO CLAIM IS MADE TO THE EXCLUSIVE RIGHT TO USE "CONFERENCE", APART FROM THE MARK AS SHOWN.

THE MARK CONSISTS OF A LAPTOP COMPUTER DESIGN FEATURING BOTH COMPUTER SCREEN AND KEYBOARD WITH 3 AGRICULTURAL CROP YIELD MAPS BEHIND THE LAPTOP AND UNDERNEATH A GLOBE WITH OUTLINE OF CONTINENTS. A SATELLITE IS IN THE UPPER RIGHT PORTION OF THE MARK, WITH A LIGHTNING-LIKE RAY TRAVELING FROM THE SATELLITE TO THE GLOBE. THE STYLIZED WORDING "THE INFOAG CONFERENCE" APPEARS ON THE LAPTOP.

FOR EDUCATIONAL SERVICES, NAMELY, CONDUCTING CONFERENCES, WORKSHOPS AND SEMINARS ON ADVANCEMENTS IN SITE SPECIFIC AGRICULTURE, ORGANIZING EDUCATIONAL EXHIBITIONS IN THE FIELD OF ADVANCEMENT IN SITE SPECIFIC AGRICULTURE (U.S. CLS. 100, 101 AND 107).

FIRST USE 7-0-1996; IN COMMERCE 7-0-1996.

TRACY WHITTAKER-BROWN, EXAMINING ATTORNEY

SN 85-170,579. SHIVANAND, ISHAN, DWARKA, NEW DELHI, INDIA, AND RATRA, SADHANA, DWARKA, NEW DELHI, INDIA, FILED 11-5-2010.

SHIV YOG

THE MARK CONSISTS OF STANDARD CHARACTERS WITHOUT CLAIM TO ANY PARTICULAR FONT, STYLE, SIZE, OR COLOR.

THE ENGLISH TRANSLATION OF "SHIV YOG" IN THE MARK IS "MERGING WITH THE INFINITE" OR "EMERGING INFINITE".

FOR ONLINE PUBLISHING OF DOCUMENTS, NAMELY, EDUCATIONAL, INSTRUCTIONAL AND TEACHING MATERIALS, STORIES, BLOG ARTICLES, AND WEB PUBLISHED NEWSLETTERS IN THE FIELDS OF CULTURE, LIFESTYLE, MOTIVATION, PERFORMANCE, PERSONAL EMPOWERMENT, PERSONAL AND PROFESSIONAL DEVELOPMENT, STRESS, PERSONAL GROWTH AND DEVELOPMENT, PERSONAL ASPIRATIONS AND GOALS, HEALTH, HEALING, NATURAL LIVING, FITNESS, EXERCISE, SPIRITUALITY, MYSTICISM, METAPHYSICS, CONSCIOUSNESS, SUBTLE BODIES AND/OR SUBTLE ENERGIES RELATED TO BODY, MIND AND SOUL CONNECTION, HEALTH, HEALING, SELF-HELP, RELATIONSHIPS, MEDITATION AND SELF-REALIZATION; PROVIDING AN ONLINE JOURNAL, NAMELY, AN INTERACTIVE WEB BLOG AND MICRO-BLOG IN THE FIELDS OF CULTURE, LIFESTYLE, MOTIVATION, PERFORMANCE, PERSONAL EMPOWERMENT, PERSONAL AND PROFESSIONAL DEVELOPMENT, STRESS, PER-

SN 85-168,264. MONTEREY BAY AQUARIUM FOUNDATION, MONTEREY, CA. FILED 11-3-2010.

SPLASH ZONE

THE MARK CONSISTS OF STANDARD CHARACTERS WITHOUT CLAIM TO ANY PARTICULAR FONT, STYLE, SIZE, OR COLOR.

OWNER OF U.S. REG. NOS. 2,466,455 AND 3,665,710.

FOR EDUCATIONAL SERVICES FOR CHILDREN AND FAMILIES, NAMELY, CONDUCTING AQUARIUM INTERACTIVE EXHIBITS AND PROGRAMS IN THE FIELDS OF SCIENCE, MARINE LIFE CONSERVATION AND HEALTHY OCEANS (U.S. CLS. 100, 101 AND 107).

FIRST USE 4-8-2000; IN COMMERCE 4-8-2000.

KRISTIN CARLSON, EXAMINING ATTORNEY

CLASS 41—(Continued).

SONAL GROWTH AND DEVELOPMENT, PERSONAL ASPIRATIONS AND GOALS, HEALTH, HEALING, NATURAL LIVING, FITNESS, EXERCISE, SPIRITUALITY, MYSTICISM, METAPHYSICS, CONSCIOUSNESS, SUBTLE BODIES AND/OR SUBTLE ENERGIES RELATED TO BODY, MIND AND SOUL CONNECTION, HEALTH, HEALING, SELF-HELP, RELATIONSHIPS, MEDITATION AND SELF-REALIZATION; EDUCATIONAL SERVICES, NAMELY, CONDUCTING SELF-DEVELOPMENT AND SPIRITUAL COURSES OF INSTRUCTION IN THE FIELD OF MEDITATION, CONSCIOUSNESS AND PRAYER-TECHNIQUES; CONDUCTING CLASSES, SEMINARS, EDUCATIONAL CONFERENCES AND WORKSHOPS IN THE FIELD OF MEDITATION, CONSCIOUSNESS, SPIRITUALITY, AND PRAYER TECHNIQUES AND DISTRIBUTING COURSE MATERIALS IN CONNECTION THEREWITH; EDUCATIONAL SERVICES, NAMELY, CONDUCTING WORKSHOPS, SEMINARS, ELECTRONIC CLASSES, ONLINE NON-DOWNLOADABLE WEBINARS AND MENTORING IN THE FIELD OF SPIRITUALITY, MYSTICISM, METAPHYSICS, CONSCIOUSNESS, SUBTLE BODIES AND/OR SUBTLE ENERGIES RELATED TO BODY, MIND AND SOUL CONNECTION AND DISTRIBUTION OF PRINTED MATERIALS IN CONNECTION THEREWITH IN HARD COPY OR ELECTRONIC FORMAT ON THE SAME TOPICS (U.S. CLS. 100, 101 AND 107).

FIRST USE 1-1-1991; IN COMMERCE 1-1-2006.
LAURIE MAYES, EXAMINING ATTORNEY

SN 85-176,457. CROI FOUNDATION, PITTSBURGH, PA.
FILED 11-15-2010.

CROI

THE MARK CONSISTS OF STANDARD CHARACTERS WITHOUT CLAIM TO ANY PARTICULAR FONT, STYLE, SIZE, OR COLOR.

FOR EDUCATIONAL SERVICES, NAMELY, CONDUCTING SCIENTIFIC AND EDUCATIONAL CONFERENCES AND PROGRAMS IN THE FIELDS OF AIDS AND HIV-RELATED INFECTIONS AND RESEARCH; DISTRIBUTING AND COMPILING MATERIALS IN CONNECTION THEREWITH IN HARD COPY OR ELECTRONIC FORMAT ON THE SAME TOPICS (U.S. CLS. 100, 101 AND 107).

FIRST USE 2-8-2004; IN COMMERCE 2-8-2004.
JACLYN KIDWELL WALKER, EXAMINING ATTORNEY

CLASS 41—(Continued).

SN 85-180,084. UBISOFT ENTERTAINMENT, RENNES, FRANCE, FILED 11-19-2010.



THE TRADEMARK CONSISTS OF A STYLIZED TRIANGLE MADE OF 3 BLACK TRAPEZOIDS.

FOR ENTERTAINMENT SERVICES, NAMELY, PROVIDING AN ON-LINE COMPUTER GAME FOR OTHERS OVER LOCAL AREA COMPUTER NETWORKS AND PROVIDING TECHNICAL INFORMATION ON-LINE RELATING TO COMPUTER GAMES, VIDEO GAMES AND COMPUTER AND VIDEO GAMES RELATED PRODUCTS (U.S. CLS. 100, 101 AND 107).

FIRST USE 10-31-2007; IN COMMERCE 10-31-2007.
JOHN WILKE, EXAMINING ATTORNEY

SN 85-190,434. CBS BROADCASTING INC., NEW YORK, NY.
FILED 12-3-2010.

**JETHRO BODINE'S BEVERLY
HILLBILLIES MANSION &
CASINO**

THE MARK CONSISTS OF STANDARD CHARACTERS WITHOUT CLAIM TO ANY PARTICULAR FONT, STYLE, SIZE, OR COLOR.

OWNER OF U.S. REG. NOS. 3,002,477, 3,510,103 AND OTHERS.

NO CLAIM IS MADE TO THE EXCLUSIVE RIGHT TO USE "MANSION & CASINO", APART FROM THE MARK AS SHOWN.

THE NAME "JETHRO BODINE" DOES NOT IDENTIFY A LIVING INDIVIDUAL.

FOR CASINO SERVICES (U.S. CLS. 100, 101 AND 107).
MAUREEN DALL, EXAMINING ATTORNEY

CLASS 41—(Continued).

SN 85-200,914. S & G HOLDINGS, INC., NASHVILLE, TN. FILED 12-17-2010.

**BURNOUT: THE ULTIMATE
DRAG RACE CHALLENGE**

THE MARK CONSISTS OF STANDARD CHARACTERS WITHOUT CLAIM TO ANY PARTICULAR FONT, STYLE, SIZE, OR COLOR.

NO CLAIM IS MADE TO THE EXCLUSIVE RIGHT TO USE "THE ULTIMATE DRAG RACE CHALLENGE", APART FROM THE MARK AS SHOWN.

FOR ENTERTAINMENT SERVICES IN THE NATURE OF CONTINUING PROGRAM SERIES, FEATURING LIVE ACTION, COMEDY AND DRAMA PROVIDED THROUGH CABLE TELEVISION, BROADCAST TELEVISION, INTERNET, VIDEO-ON-DEMAND, AND THROUGH OTHER DISTRIBUTION PLATFORMS; PROVIDING ONLINE INFORMATION IN THE FIELD OF ENTERTAINMENT CONCERNING TELEVISION PROGRAMS (U.S. CLS. 100, 101 AND 107).

JEFFERY COWARD, EXAMINING ATTORNEY

CLASS 41—(Continued).

SN 85-204,125. LOUISIANA MEDICAL MUTUAL INSURANCE COMPANY, METAIRIE, LA. FILED 12-22-2010.



THE MARK CONSISTS OF THE STYLIZED LETTERS "M" AND "I" WITH A FLOURISH ABOVE THE LETTER "I".

FOR EDUCATIONAL SERVICES, NAMELY, CONDUCTING ONLINE SEMINARS IN THE FIELD OF INSURANCE RISK MANAGEMENT (U.S. CLS. 100, 101 AND 107).

BRENDAN MCCAULEY, EXAMINING ATTORNEY

SN 85-203,971. LOUISIANA MEDICAL MUTUAL INSURANCE COMPANY, METAIRIE, LA. FILED 12-22-2010.



THE MARK CONSISTS OF THE STYLIZED LETTERS "M" AND "I" WITH A FLOURISH ABOVE THE LETTER "I" AND THE WORD "COMMUNITY" INSIDE THE LETTER "I".

FOR EDUCATIONAL SERVICES, NAMELY, CONDUCTING ONLINE SEMINARS IN THE FIELD OF INSURANCE RISK MANAGEMENT (U.S. CLS. 100, 101 AND 107).

BRENDAN MCCAULEY, EXAMINING ATTORNEY

SN 85-211,282. NUERNBERGER, TRUDY F., DBA THE GOOD NEIGHBOR DOG, SPARROWBUSH, NY. FILED 1-5-2011.

Good Neighbors

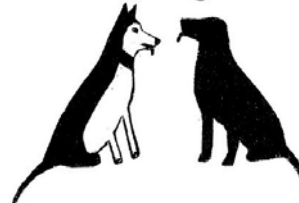

THE MARK CONSISTS OF THE WORDING "GOOD NEIGHBORS" ABOVE TWO DOGS FACING EACH OTHER. THE DOG ON LEFT HAS A SHADED BODY, WITH LIGHTENED FACE, STOMACH, FRONT LEGS AND PAWS, AND THE DOG ON THE RIGHT IS COMPLETELY SHADED.

FOR DOG TRAINING (U.S. CLS. 100, 101 AND 107). FIRST USE 6-1-2011; IN COMMERCE 6-1-2011.

ANDREA K. NADELMAN, EXAMINING ATTORNEY

CLASS 41—(Continued).

SN 85-213,922. SOUDI, ABDESALAM, PITTSBURGH, PA.
FILED 1-10-2011.

Dialogistics

THE MARK CONSISTS OF STANDARD CHARACTERS WITHOUT CLAIM TO ANY PARTICULAR FONT, STYLE, SIZE, OR COLOR.

FOR EDUCATIONAL SERVICES, NAMELY, PROVIDING CLASSES, SEMINARS, AND TRAININGS IN THE FIELDS OF LOGISTICS OF DIALOGUE, HUMAN-COMPUTER INTERFACE IN PHYSICIANS' CONSULTATIONS, MEDICAL DISCOURSE ANALYSIS, ARABIC LINGUISTICS, THE ROLE OF ELECTRONIC HEALTH RECORDS IN MEDICAL INTERVIEWS, CONVERSATION ANALYSIS, LANGUAGE TEACHING, INSTITUTIONAL DISCOURSE ANALYSIS, CULTURAL AND LINGUISTIC COMPETENCY TRAININGS, MULTIMODAL INTERACTION, BODY LANGUAGE, HIGH QUALITY LANGUAGE TRANSLATION AND LANGUAGE INTERPRETING SERVICES, AND TRAININGS FOR COMMUNITY AND GOVERNMENT ORGANIZATIONS ON TOPICS RELATED TO CROSS-CULTURAL COMMUNICATION (U.S. CLS. 100, 101 AND 107).

JAY FLOWERS, EXAMINING ATTORNEY

CLASS 41—(Continued).

SN 85-216,520. DULCE GUZMAN DE PORTER, LAS VEGAS, NV. FILED 1-13-2011.

FURIA DE ARRANQUE

THE MARK CONSISTS OF STANDARD CHARACTERS WITHOUT CLAIM TO ANY PARTICULAR FONT, STYLE, SIZE, OR COLOR.

THE ENGLISH TRANSLATION OF "FURIA DE ARRANQUE" IN THE MARK IS "FURIOUS TO START".

FOR ENTERTAINMENT IN THE NATURE OF VISUAL AND AUDIO PERFORMANCES, NAMELY, MUSICAL BAND, ROCK GROUP, GYMNASTIC, DANCE, AND BALLET PERFORMANCES (U.S. CLS. 100, 101 AND 107).

FIRST USE 4-26-2007; IN COMMERCE 7-1-2008.

CARRIE GENOVESE, EXAMINING ATTORNEY

SN 85-216,399. IMI PLC, BIRMINGHAM, UNITED KINGDOM, FILED 1-12-2011.

IMI SEVERE SERVICE UNIVERSITY

THE MARK CONSISTS OF STANDARD CHARACTERS WITHOUT CLAIM TO ANY PARTICULAR FONT, STYLE, SIZE, OR COLOR.

OWNER OF U.S. REG. NO. 3,308,032.

NO CLAIM IS MADE TO THE EXCLUSIVE RIGHT TO USE "SEVERE SERVICE UNIVERSITY", APART FROM THE MARK AS SHOWN.

FOR TRAINING IN THE USE OF SYSTEMS AND EQUIPMENT FOR CONTROLLING INDUSTRIAL PROCESSES; TRAINING IN THE USE OF CONTROL VALVES AND VALVE ACTUATORS FOR REGULATING THE FLOW OF GASES AND LIQUIDS; PROVIDING ONLINE TUTORING ON THE USE OF INDUSTRIAL PROCESS CONTROL SYSTEMS, CONTROL VALVES, AND VALVE ACTUATORS (U.S. CLS. 100, 101 AND 107).

ALYSSA STEEL, EXAMINING ATTORNEY

SN 85-221,319. STANLEY WORLD, LTD., PINE BROOK, NJ. FILED 1-19-2011.

ASSUMPTION OF COMMONALITY

THE MARK CONSISTS OF STANDARD CHARACTERS WITHOUT CLAIM TO ANY PARTICULAR FONT, STYLE, SIZE, OR COLOR.

FOR EDUCATIONAL AND ENTERTAINMENT SERVICES, NAMELY, CONDUCTING SEMINARS AND MOTIVATIONAL SPEECHES IN THE FIELD OF PERSONAL IMPROVEMENT (U.S. CLS. 100, 101 AND 107).

MARTHA FROMM, EXAMINING ATTORNEY

CLASS 41—(Continued).

SN 85-223,253. HAMSHER, KIMBERLY CHRISTINE., LAS VEGAS, NV. FILED 1-21-2011.



NO CLAIM IS MADE TO THE EXCLUSIVE RIGHT TO USE "FITNESS", APART FROM THE MARK AS SHOWN.

THE COLOR(S) COPPER, BLUE, GREEN, AND PURPLE IS/ARE CLAIMED AS A FEATURE OF THE MARK.

THE MARK CONSISTS OF "FUND00" LETTERS IN COPPER/BLUE GRADIENT, "FITNESS" LETTERS IN COPPER, "MAINTAINING THE HUMAN MACHINE" TAGLINE LETTERS IN BLUE, A BLUE ROBOT WITH COPPER EYES, OIL CAN, MOUTH, TOP OF HEAD, HANDS AND FEET, GREEN BALL JOINTS, AND A PURPLE LOTUS FLOWER.

FOR PROVIDING A WEB SITE FEATURING INFORMATION ON EXERCISE AND FITNESS; PROVIDING ASSISTANCE, PERSONAL TRAINING AND PHYSICAL FITNESS CONSULTATION TO INDIVIDUALS TO HELP THEM MAKE PHYSICAL FITNESS, STRENGTH, CONDITIONING, AND EXERCISE IMPROVEMENT IN THEIR DAILY LIVING; PROVIDING CLASSES, WORKSHOPS, SEMINARS AND CAMPS IN THE FIELDS OF FITNESS, EXERCISE, BOXING, KICK BOXING AND MIXED MARTIAL ARTS; PROVIDING INFORMATION ON PHYSICAL EXERCISE (U.S. CLS. 100, 101 AND 107).
FIRST USE 11-28-2010; IN COMMERCE 1-20-2011.

JACQUELINE A. LAVINE, EXAMINING ATTORNEY

SN 85-229,341. TWENTIETH CENTURY FOX FILM CORPORATION, LOS ANGELES, CA. FILED 1-28-2011.

FOX SPORTS GAME LOUNGE

THE MARK CONSISTS OF STANDARD CHARACTERS WITHOUT CLAIM TO ANY PARTICULAR FONT, STYLE, SIZE, OR COLOR.

NO CLAIM IS MADE TO THE EXCLUSIVE RIGHT TO USE "SPORTS GAME", APART FROM THE MARK AS SHOWN.

FOR PROVIDING ON-LINE INFORMATION IN THE FIELD OF SPORTS VIA THE INTERNET; ENTERTAINMENT SERVICES IN THE NATURE OF NON-DOWNLOADABLE VIDEOS AND IMAGES FEATURING SPORTS TRANSMITTED VIA THE INTERNET (U.S. CLS. 100, 101 AND 107).

ANTHONY RINKER, EXAMINING ATTORNEY

CLASS 41—(Continued).

SN 85-231,063. TRADE PRESS MEDIA GROUP, INC., MILWAUKEE, WI. FILED 2-1-2011.

SUSTAIN SMART SERIES

THE MARK CONSISTS OF STANDARD CHARACTERS WITHOUT CLAIM TO ANY PARTICULAR FONT, STYLE, SIZE, OR COLOR.

NO CLAIM IS MADE TO THE EXCLUSIVE RIGHT TO USE "SERIES", APART FROM THE MARK AS SHOWN.

FOR EDUCATIONAL SERVICES, NAMELY, THE OFFERING OF WEB BASED E-LEARNING PROGRAMS IN THE FIELD OF INITIATING, EVALUATING AND PURSUING SUSTAINABILITY PLANS FOR BUILDINGS AND FACILITIES (U.S. CLS. 100, 101 AND 107).

TIMOTHY FINNEGAN, EXAMINING ATTORNEY

SN 85-231,967. JACKSON SUMMIT IP HOLDING CORP., WILTON MANORS, FL. FILED 2-2-2011.

Final Focus

THE MARK CONSISTS OF STANDARD CHARACTERS WITHOUT CLAIM TO ANY PARTICULAR FONT, STYLE, SIZE, OR COLOR.

FOR EDUCATIONAL SERVICES, NAMELY, PROVIDING TRAINING IN THE FIELD OF VERBAL AND NON-VERBAL COMMUNICATION SKILLS DEVELOPMENT (U.S. CLS. 100, 101 AND 107).

FIRST USE 4-30-2011; IN COMMERCE 4-30-2011.

KAREN BRACEY, EXAMINING ATTORNEY

SN 85-232,080. NANCY W. CHILDRESS, DBA PEERS SHARING SUCCESS, GILMANTON, NH. FILED 2-2-2011.

PSS.

THE MARK CONSISTS OF STANDARD CHARACTERS WITHOUT CLAIM TO ANY PARTICULAR FONT, STYLE, SIZE, OR COLOR.

FOR EDUCATIONAL SERVICES, NAMELY, CONDUCTING WORKSHOPS, SEMINARS IN IMPROVING STUDENT ACHIEVEMENT IN THE FIELD OF ELEMENTARY AND SECONDARY SCHOOL SUBJECTS AND DISTRIBUTION OF TRAINING MATERIAL IN CONNECTION THEREWITH (U.S. CLS. 100, 101 AND 107).

FIRST USE 1-26-2011; IN COMMERCE 1-26-2011.

ANDREW LEASER, EXAMINING ATTORNEY

CLASS 41—(Continued).

SN 85-232,846. LEHIGH VALLEY ORGANIC GROWERS INC., DBA AGRISYSTEMS INTERNATIONAL, WIND GAP, PA. FILED 2-2-2011.

Sustainability: The Great Conversation

THE MARK CONSISTS OF STANDARD CHARACTERS WITHOUT CLAIM TO ANY PARTICULAR FONT, STYLE, SIZE, OR COLOR.

NO CLAIM IS MADE TO THE EXCLUSIVE RIGHT TO USE "SUSTAINABILITY", APART FROM THE MARK AS SHOWN.

FOR BUSINESS EDUCATION AND TRAINING SERVICES, NAMELY, DEVELOPING AND FACILITATING CUSTOMIZED LEADERSHIP AND EXECUTIVE DEVELOPMENT PROGRAMS, PROVIDING EXECUTIVE COACHING SERVICES, AND PROVIDING BUSINESS EDUCATION PROGRAMS TO EMPLOYEES AND EXECUTIVES; EDUCATIONAL SERVICES, NAMELY, CONDUCTING SEMINARS, CONFERENCES, LECTURES, AND COURSES IN THE FIELD OF SUSTAINABILITY OF BUSINESS, ENVIRONMENTAL, AGRICULTURAL, ENERGY, AND HEALTH PRACTICES, AND DISTRIBUTION OF COURSE AND EDUCATIONAL MATERIALS IN CONNECTION THEREWITH; ENTERTAINMENT AND EDUCATIONAL SERVICES, NAMELY, THE PRESENTATION OF SEMINARS, LECTURES, WORKSHOPS AND PANEL DISCUSSIONS, AND ONGOING TELEVISION AND RADIO TALK SHOWS ALL IN THE FIELD OF PUBLIC INTEREST CONCERNING SUSTAINABILITY OF BUSINESS, ENVIRONMENTAL, AGRICULTURAL, ENERGY, AND HEALTH PRACTICES (U.S. CLS. 100, 101 AND 107).

BILL DAWE, EXAMINING ATTORNEY

SN 85-234,713. INSTITUTE OF MANAGEMENT ACCOUNTANTS, MONTVALE, NJ. FILED 2-4-2011.

STRATEGIC FINANCE

THE MARK CONSISTS OF STANDARD CHARACTERS WITHOUT CLAIM TO ANY PARTICULAR FONT, STYLE, SIZE, OR COLOR.

SEC. 2(F).

FOR PROVIDING ONLINE PUBLICATIONS IN THE NATURE OF MAGAZINES DEVOTED TO FINANCIAL EXECUTIVES AND MANAGEMENT ACCOUNTANTS (U.S. CLS. 100, 101 AND 107).

FIRST USE 3-19-1999; IN COMMERCE 3-19-1999.
SUE LAWRENCE, EXAMINING ATTORNEY

CLASS 41—(Continued).

SN 85-235,329. METROPOLITAN LIFE INSURANCE COMPANY, NEW YORK, NY. FILED 2-7-2011.

LEAD. LOAN EDUCATION AND DIRECTION WITH METLIFE

THE MARK CONSISTS OF STANDARD CHARACTERS WITHOUT CLAIM TO ANY PARTICULAR FONT, STYLE, SIZE, OR COLOR.

OWNER OF U.S. REG. NOS. 1,541,862, 3,929,260 AND OTHERS.

NO CLAIM IS MADE TO THE EXCLUSIVE RIGHT TO USE "LOAN EDUCATION", APART FROM THE MARK AS SHOWN.

FOR EDUCATION SERVICES, NAMELY, PROVIDING SEMINARS AND WORKSHOPS IN THE FIELDS OF PERSONAL FINANCE (U.S. CLS. 100, 101 AND 107).

MAUREEN DALL, EXAMINING ATTORNEY

SN 85-236,369. KANDI KOATED ENTERTAINMENT, INC., EAST POINT, GA. FILED 2-8-2011.

KANDI KOATED NIGHTS

THE MARK CONSISTS OF STANDARD CHARACTERS WITHOUT CLAIM TO ANY PARTICULAR FONT, STYLE, SIZE, OR COLOR.

THE NAME(S), PORTRAIT(S), AND/OR SIGNATURE(S) SHOWN IN THE MARK IDENTIFIES "KANDI" BURRUSS, WHOSE CONSENT(S) TO REGISTER IS MADE OF RECORD.

FOR ENTERTAINMENT SERVICES, NAMELY, ON GOING SERIES OF TALK SHOWS THAT INCLUDE REALITY AND NON-FICTION WEBISODES BROADCAST OVER THE INTERNET IN THE FIELD OF SEX AND RELATIONSHIPS; (BASED ON INTENT TO USE AS SET FORTH IN THE APPLICATION) ENTERTAINMENT SERVICES, NAMELY, ON GOING SERIES OF TELEVISION TALK SHOWS THAT INCLUDE REALITY AND NON-FICTION EPISODES IN THE FIELD OF SEX AND RELATIONSHIPS (U.S. CLS. 100, 101 AND 107).

FIRST USE 2-3-2010; IN COMMERCE 2-3-2010.
JENNY PARK, EXAMINING ATTORNEY

CLASS 41—(Continued).

SN 85-236,967. MARRAKESH COUNTRY CLUB, PALM DESERT, CA. FILED 2-8-2011.



THE COLOR(S) GREEN, CORAL, AND WHITE IS/ARE CLAIMED AS A FEATURE OF THE MARK.

THE MARK CONSISTS OF THE MARK CONSISTS OF A WHITE BACKGROUND WITH A GREEN LETTER 'M' WITH A SOLID CORAL COLORED LINE UNDERNEATH AND CORAL COLORED ROOF ABOVE, WITH A FLAG ON IT.

FOR COUNTRY CLUBS (U.S. CLS. 100, 101 AND 107).
FIRST USE 1-12-2011; IN COMMERCE 1-12-2011.
JAMES A. RAUEN, EXAMINING ATTORNEY

CLASS 41—(Continued).

SN 85-239,527. TRAVIS, ERIC, VALLEY VILLAGE, CA. FILED 2-10-2011.



THE MARK CONSISTS OF A STYLIZED FORM OF THE WORD "METALACHI" AS WELL AS THE WEBSITE URL "WWW.METALACHI.COM". THE WORD "METALACHI" CONSISTS OF THE LETTER "T" STYLED WITH POINTED TIPS CONSISTENT WITH HORNS OR A PITCHFORK. A SMALL SKULL WITH A ROSE IN ITS MOUTH IS IMPOSED BETWEEN THE LETTER "L" AND "A" INSIDE A CIRCULAR FIELD. THE FOLLOWING LETTERS (M, T, L, CAPITAL A, H AND I) ARE STYLIZED WITH SHARP POINTS, SIMILAR TO A KNIFE EDGE OR BLADE. THE BLACK RECTANGULAR BACKGROUND IS NOT PART OF THE MARK.

FOR ENTERTAINMENT SERVICES IN THE NATURE OF LIVE MUSICAL PERFORMANCES (U.S. CLS. 100, 101 AND 107).

FIRST USE 6-16-2009; IN COMMERCE 4-27-2010.
MICHAEL ENGEL, EXAMINING ATTORNEY

SN 85-243,068. CBS BROADCASTING INC., NEW YORK, NY. FILED 2-15-2011.

CBS SPORTS NETWORK

THE MARK CONSISTS OF STANDARD CHARACTERS WITHOUT CLAIM TO ANY PARTICULAR FONT, STYLE, SIZE, OR COLOR.

OWNER OF U.S. REG. NOS. 852,481, 3,616,830 AND OTHERS.

NO CLAIM IS MADE TO THE EXCLUSIVE RIGHT TO USE "SPORTS NETWORK", APART FROM THE MARK AS SHOWN.

FOR ENTERTAINMENT SERVICES, NAMELY, A PRODUCTION AND DISTRIBUTION OF TELEVISION PROGRAMS FEATURING SPORTS, NEWS AND CURRENT AFFAIRS RENDERED THROUGH THE MEDIA OF TELEVISION, CABLE, SATELLITE, RADIO, TELEPHONE AND BROADBAND SYSTEMS, AND VIA THE INTERNET AND PORTABLE AND WIRELESS COMMUNICATION DEVICES; PROVIDING INFORMATION IN THE FIELD OF ENTERTAINMENT RENDERED VIA THE INTERNET, AND PORTABLE AND WIRELESS COMMUNICATION DEVICES; INTERACTIVE ENTERTAINMENT SERVICES, PROVIDING PERSONALIZED TELEVISION PROGRAMMING; PROVIDING ONLINE AND ON-SCREEN GUIDE TO PERSONALIZED AND INTERACTIVE TELEVISION PROGRAMMING (U.S. CLS. 100, 101 AND 107).

DAVID TOOLEY, EXAMINING ATTORNEY

SN 85-238,642. GROH PRODUCTIONS, INC., CHICAGO, IL. FILED 2-10-2011.

RESET & RE-IMAGINE

THE MARK CONSISTS OF STANDARD CHARACTERS WITHOUT CLAIM TO ANY PARTICULAR FONT, STYLE, SIZE, OR COLOR.

FOR PRODUCTION OF INSTRUCTIONAL VIDEOS USED FOR CORPORATE, PERSONAL AND ORGANIZATIONAL TRAINING FOR DEVELOPING LEADERSHIP, TEAM BUILDING AND CUSTOMER SERVICE; CORPORATE, INDIVIDUAL, AND ORGANIZATIONAL TRAINING IN THE FIELDS OF LEADERSHIP DEVELOPMENT, TEAM BUILDING, AND CUSTOMER SERVICE; AND PROVIDING A WEB SITE FEATURING NON-DOWNLOADABLE INSTRUCTIONAL VIDEOS FOR CORPORATE, PERSONAL, AND ORGANIZATIONAL TRAINING IN THE FIELDS OF LEADERSHIP DEVELOPMENT, TEAM BUILDING AND CUSTOMER SERVICE (U.S. CLS. 100, 101 AND 107).

TARA PATE, EXAMINING ATTORNEY

CLASS 41—(Continued).

SN 85-243,619. GOKHMAN, MAX E, SAN FRANCISCO, CA. AND LU, LI, SAN FRANCISCO, CA. FILED 2-16-2011.

Chartered Quantitative Analyst

THE MARK CONSISTS OF STANDARD CHARACTERS WITHOUT CLAIM TO ANY PARTICULAR FONT, STYLE, SIZE, OR COLOR.

NO CLAIM IS MADE TO THE EXCLUSIVE RIGHT TO USE "QUANTITATIVE ANALYST", APART FROM THE MARK AS SHOWN.

FOR EDUCATIONAL SERVICES, NAMELY, CONDUCTING AND PROVIDING COURSES OF INSTRUCTION, WORKSHOPS, SEMINARS, AND CONFERENCES IN THE FIELD OF QUANTITATIVE AND FINANCIAL ANALYSIS AND DISTRIBUTION OF COURSE AND EDUCATIONAL MATERIALS IN CONNECTION THEREWITH (U.S. CLS. 100, 101 AND 107).

JAY FLOWERS, EXAMINING ATTORNEY

SN 85-243,893. JASMARC GAMING LLC, CERRITOS, CA. FILED 2-16-2011.

Funtazee 21

THE MARK CONSISTS OF STANDARD CHARACTERS WITHOUT CLAIM TO ANY PARTICULAR FONT, STYLE, SIZE, OR COLOR.

NO CLAIM IS MADE TO THE EXCLUSIVE RIGHT TO USE "21", APART FROM THE MARK AS SHOWN.

FOR ENTERTAINMENT SERVICES, NAMELY, CASINO GAMING; GAMING SERVICES IN THE NATURE OF CASINO GAMING (U.S. CLS. 100, 101 AND 107).

FIRST USE 11-30-2010; IN COMMERCE 11-30-2010.
C. DIONNE CLYBURN, EXAMINING ATTORNEY

CLASS 41—(Continued).

SN 85-247,423. EFRON, HOWARD, CLIFTON, NJ. FILED 2-21-2011.

JEREMY COLE

THE MARK CONSISTS OF STANDARD CHARACTERS WITHOUT CLAIM TO ANY PARTICULAR FONT, STYLE, SIZE, OR COLOR.

THE NAME(S), PORTRAIT(S), AND/OR SIGNATURE(S) SHOWN IN THE MARK IDENTIFIES "JEREMY COLE", WHOSE CONSENT(S) TO REGISTER IS MADE OF RECORD.

FOR ENTERTAINMENT IN THE NATURE OF LIVE PERFORMANCES BY A MUSICAL ARTIST OR MUSIC GROUP; ENTERTAINMENT IN THE NATURE OF LIVE STAGE PERFORMANCES IN THE NATURE OF CONCERTS; LIVE ENTERTAINMENT IN THE NATURE OF VISUAL AND AUDIO PERFORMANCES, NAMELY, MUSICAL BAND OR MUSICAL ARTIST PERFORMANCES; ENTERTAINMENT INFORMATION SERVICES, NAMELY, PROVIDING INFORMATION AND NEWS RELEASES ABOUT A MUSICAL ARTIST; ENTERTAINMENT SERVICES IN THE NATURE OF LIVE MUSICAL PERFORMANCES; ENTERTAINMENT SERVICES, NAMELY, PROVIDING A WEB SITE FEATURING NON-DOWNLOADABLE MUSICAL PERFORMANCES, MUSICAL VIDEOS, RELATED FILM CLIPS, PHOTOGRAPHS, AND OTHER MULTIMEDIA MATERIALS FEATURING MUSIC; ENTERTAINMENT SERVICES, NAMELY, PROVIDING INFORMATION ABOUT A RECORDING ARTIST VIA AN ONLINE NETWORK; ENTERTAINMENT SERVICES, NAMELY, PROVIDING NON-DOWNLOADABLE PLAYBACK OF MUSIC VIA GLOBAL COMMUNICATIONS NETWORKS; ENTERTAINMENT SERVICES, NAMELY, PROVIDING NON-DOWNLOADABLE PRERECORDED MUSIC, INFORMATION IN THE FIELD OF MUSIC, AND COMMENTARY AND ARTICLES ABOUT MUSIC, ALL ONLINE VIA A GLOBAL COMPUTER NETWORK; ENTERTAINMENT, NAMELY, LIVE MUSIC CONCERTS; ENTERTAINMENT, NAMELY, LIVE PERFORMANCES BY A MUSICAL SINGER AND/OR MUSICAL BAND; ENTERTAINMENT, NAMELY, LIVE PERFORMANCES BY MUSICAL SINGER AND/OR MUSICAL BANDS; ENTERTAINMENT, NAMELY, LIVE PERFORMANCES BY MUSICAL SINGERS AND MUSIC GROUPS (U.S. CLS. 100, 101 AND 107).

FIRST USE 7-1-2004; IN COMMERCE 6-19-2006.
THEODORE MCBRIDE, EXAMINING ATTORNEY

CLASS 41—(Continued).

SN 85-247,695. CALLENDER, PAMELA E, NEPTUNE, NJ. FILED 2-21-2011.

My Recycle Buddies

THE MARK CONSISTS OF STANDARD CHARACTERS WITHOUT CLAIM TO ANY PARTICULAR FONT, STYLE, SIZE, OR COLOR.

NO CLAIM IS MADE TO THE EXCLUSIVE RIGHT TO USE "RECYCLE", APART FROM THE MARK AS SHOWN.

FOR EDUCATIONAL SERVICES, NAMELY, PROVIDING ONLINE INSTRUCTION IN THE FIELD OF RECYCLING AND THE ENVIRONMENT VIA AN ONLINE WEBSITE; ENTERTAINMENT SERVICES, NAMELY, PROVIDING A WEBSITE FEATURING GAMES AND PUZZLES; PROVIDING A WEBSITE FEATURING INFORMATION IN THE FIELDS OF EDUCATION AND ENTERTAINMENT FOR CHILDREN (U.S. CLS. 100, 101 AND 107).

RENEE MCCRAY, EXAMINING ATTORNEY

SN 85-248,160. REANI, BERNARDINO, ALEXANDRIA, VA. FILED 2-22-2011.

DICTIONARY

THE MARK CONSISTS OF STANDARD CHARACTERS WITHOUT CLAIM TO ANY PARTICULAR FONT, STYLE, SIZE, OR COLOR.

FOR ENTERTAINMENT IN THE NATURE OF A TELEVISION GAME SHOW (U.S. CLS. 100, 101 AND 107).

JAMES LOVELACE, EXAMINING ATTORNEY

SN 85-250,214. PRESTON, PAUL, BURBANK, CA. FILED 2-24-2011.

THE MOVIE GUYS

THE MARK CONSISTS OF STANDARD CHARACTERS WITHOUT CLAIM TO ANY PARTICULAR FONT, STYLE, SIZE, OR COLOR.

NO CLAIM IS MADE TO THE EXCLUSIVE RIGHT TO USE "MOVIE", APART FROM THE MARK AS SHOWN.

FOR ENTERTAINMENT SERVICES, NAMELY, PROVIDING ON-LINE REVIEWS OF MOVIES; ENTERTAINMENT SERVICES IN THE NATURE OF COMEDY SHOWS; COMEDY SHOWS BROADCAST OVER TELEVISION, SATELLITE, AUDIO, AND VIDEO MEDIA (U.S. CLS. 100, 101 AND 107).

FIRST USE 7-10-2002; IN COMMERCE 8-19-2009.

KARANENDRA S. CHHINA, EXAMINING ATTORNEY

CLASS 41—(Continued).

SN 85-250,873. PERRY INTERNATIONAL CORPORATION, ORLANDO, FL. FILED 2-24-2011.

GLOBAL SAFETY COUNCIL

THE MARK CONSISTS OF STANDARD CHARACTERS WITHOUT CLAIM TO ANY PARTICULAR FONT, STYLE, SIZE, OR COLOR.

SEC. 2(F).

FOR EDUCATIONAL SERVICES, NAMELY, CONDUCTING CLASSES, SEMINARS, CONFERENCES, AND WORKSHOPS IN THE FIELD OF OCCUPATIONAL SAFETY (U.S. CLS. 100, 101 AND 107).

FIRST USE 3-31-2006; IN COMMERCE 3-31-2006.

KATHY DE JONGE, EXAMINING ATTORNEY

SN 85-252,636. NIGHTONLYVISUAL, LLC, OCEAN GROVE, NJ. AND LISS, SCOTT A., OCEAN GROVE, NJ. FILED 2-26-2011.

The Sixty-Six

THE MARK CONSISTS OF STANDARD CHARACTERS WITHOUT CLAIM TO ANY PARTICULAR FONT, STYLE, SIZE, OR COLOR.

FOR ENTERTAINMENT, NAMELY, LIVE PERFORMANCES BY A MUSICAL BAND; LIVE PERFORMANCES BY A MUSICAL GROUP (U.S. CLS. 100, 101 AND 107).

FIRST USE 10-26-2010; IN COMMERCE 10-26-2010.

ZACHARY BELLO, EXAMINING ATTORNEY

CLASS 41—(Continued).

SN 85-253,581. HARD CANDY GIRLS LLC, COLUMBUS, OH. FILED 2-28-2011.



NO CLAIM IS MADE TO THE EXCLUSIVE RIGHT TO USE "GIRLS", APART FROM THE MARK AS SHOWN.

THE MARK CONSISTS OF AN ARC WITH FLAMES SUPERIMPOSED A PAIR OF WINGS OVER IT AND A SHIELD BEARING STARS ALONG ITS UPPER EDGE, WITH THE SILHOUETTE OF A DANCING WOMAN SUPERIMPOSED OVER THE SHIELD AND THE WORDS "THE HARD CANDY GIRLS" SUPERIMPOSED OVER THE DANCING WOMAN AND THE SHIELD, WITH A SHADOW DESIGN UNDERNEATH THE SHIELD.

FOR ENTERTAINMENT SERVICES, NAMELY, ENTERTAINMENT SERVICES IN THE NATURE OF PRESENTATION OF LIVE SHOW PERFORMANCES BY DANCERS, ENTERTAINERS AND MODELS; CONDUCTING CONTESTS AND LIVE SHOW PERFORMANCES BY DANCERS, ENTERTAINERS AND MODELS, NAMELY, DANCING, SINGING, PAGEANTS, AND POSING FOR PHOTOS; ENTERTAINMENT SERVICES, NAMELY, PERSONAL APPEARANCES BY MODELS OR DANCERS; ENTERTAINMENT SERVICES, NAMELY, LIVE APPEARANCES AT FIGHT RINGS BY PROFESSIONAL ENTERTAINERS (U.S. CLS. 100, 101 AND 107).

FIRST USE 7-20-2010; IN COMMERCE 1-1-2011.
DOUGLAS LEE, EXAMINING ATTORNEY

CLASS 41—(Continued).

SN 85-254,041. SONY ONLINE ENTERTAINMENT LLC, SAN DIEGO, CA. FILED 2-28-2011.

VENGEFUL GODS

THE MARK CONSISTS OF STANDARD CHARACTERS WITHOUT CLAIM TO ANY PARTICULAR FONT, STYLE, SIZE, OR COLOR.

FOR ENTERTAINMENT SERVICES, NAMELY, OPERATING A MULTIPLAYER, ROLE PLAYING, REAL TIME GAME FOR OTHERS VIA THE INTERNET AND LOCAL AREA COMPUTER NETWORKS (U.S. CLS. 100, 101 AND 107).

FIRST USE 2-23-2010; IN COMMERCE 2-23-2010.
FRANK LATTUCA, EXAMINING ATTORNEY

SN 85-254,244. O'BRIEN, MARC DAVID, DBA WRITING BOOKS FOR CHILDREN, LAS VEGAS, NV. FILED 3-1-2011.

Peter the Peteeatrck Panda

SN 85-253,965. AZTECA INTERNATIONAL CORPORATION, GLENDALE, CA. FILED 2-28-2011.

HIT M3

THE MARK CONSISTS OF STANDARD CHARACTERS WITHOUT CLAIM TO ANY PARTICULAR FONT, STYLE, SIZE, OR COLOR.

NO CLAIM IS MADE TO THE EXCLUSIVE RIGHT TO USE "HIT", APART FROM THE MARK AS SHOWN.

FOR ENTERTAINMENT SERVICES IN THE NATURE OF ONGOING TELEVISION PROGRAM FEATURING MUSIC AND MUSIC VIDEOS (U.S. CLS. 100, 101 AND 107).

FIRST USE 1-1-2011; IN COMMERCE 1-1-2011.
TASNEEM HUSSAIN, EXAMINING ATTORNEY

THE MARK CONSISTS OF STANDARD CHARACTERS WITHOUT CLAIM TO ANY PARTICULAR FONT, STYLE, SIZE, OR COLOR.

FOR CHARITABLE SERVICES, NAMELY, PROVIDING BOOKS TO CHILDREN FACING ADVERSITY, WOUNDED VETERANS AND DISABLED PEOPLE; CUSTOM WRITING SERVICES; EDUCATIONAL AND ENTERTAINMENT SERVICES FOR CHILDREN, NAMELY, PROVIDING INTERACTIVE PLAY AREAS, INSTRUCTIONAL CLASSES IN THE FIELDS OF HEALTH, LITERACY AND LIFE EXPERIENCES AND SOCIAL GATHERINGS FOR CHILDREN; PROVIDING ADVICE AND INFORMATION IN THE FIELD OF EDUCATIONAL AND ENTERTAINMENT ACTIVITIES AND EVENTS FOR CHILDREN; PROVIDING ON-LINE PUBLICATIONS IN THE NATURE OF AN E-BOOK IN THE FIELDS OF HEALTH, LITERACY, COMMUNICATION SKILLS, AND THERAPEUTIC HORSEBACK RIDING; PROVISION OF INFORMATION RELATING TO EDUCATIONAL AND ENTERTAINMENT ACTIVITIES AND EVENTS FOR CHILDREN; WRITING OF ARTICLES FOR JOURNALS OTHER THAN FOR ADVERTISING OR PUBLICITY; WRITING OF ARTICLES FOR PROFESSIONAL JOURNALS OTHER THAN FOR ADVERTISING OR PUBLICITY; WRITING OF TEXTS (U.S. CLS. 100, 101 AND 107).

HAI-LY LAM, EXAMINING ATTORNEY

CLASS 41—(Continued).

SN 85-256,133. CBS BROADCASTING INC., NEW YORK, NY. FILED 3-2-2011.



OWNER OF U.S. REG. NOS. 852,481, 3,616,830 AND OTHERS.

NO CLAIM IS MADE TO THE EXCLUSIVE RIGHT TO USE "SPORTS NETWORK", APART FROM THE MARK AS SHOWN.

THE MARK CONSISTS OF AN EYE WITH THE WORDS "CBS SPORTS" ABOVE A CENTER LINE AND THE WORD "NETWORK" BELOW THE CENTER LINE.

FOR ENTERTAINMENT SERVICES, NAMELY A PRODUCTION AND DISTRIBUTION OF TELEVISION PROGRAMS FEATURING SPORTS, NEWS AND CURRENT AFFAIRS RENDERED THROUGH THE MEDIA OF TELEVISION, CABLE, SATELLITE, RADIO, TELEPHONE AND BROADBAND SYSTEMS, AND VIA THE INTERNET AND PORTABLE AND WIRELESS COMMUNICATION DEVICES; PROVIDING INFORMATION IN THE FIELD OF ENTERTAINMENT RENDERED VIA THE INTERNET, AND PORTABLE AND WIRELESS COMMUNICATION DEVICES; INTERACTIVE ENTERTAINMENT SERVICES, PROVIDING PERSONALIZED TELEVISION PROGRAMMING; PROVIDING ONLINE AND ON-SCREEN GUIDE TO PERSONALIZED AND INTERACTIVE TELEVISION PROGRAMMING (U.S. CLS. 100, 101 AND 107).

DAVID TOOLEY, EXAMINING ATTORNEY

CLASS 41—(Continued).

SN 85-256,575. SONY ONLINE ENTERTAINMENT LLC, SAN DIEGO, CA. FILED 3-3-2011.

LEGACIES

THE MARK CONSISTS OF STANDARD CHARACTERS WITHOUT CLAIM TO ANY PARTICULAR FONT, STYLE, SIZE, OR COLOR.

FOR ENTERTAINMENT SERVICES, NAMELY, OPERATING A MULTIPLAYER, ROLE PLAYING, REAL TIME GAME FOR OTHERS VIA THE INTERNET AND LOCAL AREA COMPUTER NETWORKS (U.S. CLS. 100, 101 AND 107).

FIRST USE 3-1-2011; IN COMMERCE 3-1-2011.
FRANK LATTUCA, EXAMINING ATTORNEY

SN 85-256,214. PLUS/MINUS YADA YADA, LLC, WOODLAND HILLS, CA. FILED 3-2-2011.

SCORE SOUNDER

THE MARK CONSISTS OF STANDARD CHARACTERS WITHOUT CLAIM TO ANY PARTICULAR FONT, STYLE, SIZE, OR COLOR.

NO CLAIM IS MADE TO THE EXCLUSIVE RIGHT TO USE "SCORE", APART FROM THE MARK AS SHOWN.

FOR ENTERTAINMENT SERVICES, NAMELY, PROVIDING INFORMATION ON SPORTS AND GENERAL INTEREST MATTERS FOR ENTERTAINMENT PURPOSES VIA MOBILE TELEPHONES AND OTHER HANDHELD ELECTRONIC DEVICES (U.S. CLS. 100, 101 AND 107).

DAWN HAN, EXAMINING ATTORNEY

SN 85-256,763. PLUS/MINUS YADA YADA, LLC, WOODLAND HILLS, CA. FILED 3-3-2011.

SOUNDER

THE MARK CONSISTS OF STANDARD CHARACTERS WITHOUT CLAIM TO ANY PARTICULAR FONT, STYLE, SIZE, OR COLOR.

FOR ENTERTAINMENT SERVICES, NAMELY, PROVIDING INFORMATION ON SPORTS AND GENERAL INTEREST MATTERS FOR ENTERTAINMENT PURPOSES VIA MOBILE TELEPHONES AND OTHER HANDHELD ELECTRONIC DEVICES (U.S. CLS. 100, 101 AND 107).

DAWN HAN, EXAMINING ATTORNEY

CLASS 41—(Continued).

SN 85-259,004. GRANGER, DAURENT, MIDLOTHIAN, VA. FILED 3-5-2011.

Silverdrop

THE MARK CONSISTS OF STANDARD CHARACTERS WITHOUT CLAIM TO ANY PARTICULAR FONT, STYLE, SIZE, OR COLOR.

FOR ENTERTAINMENT SERVICES, NAMELY, LIVE, TELEVISED AND MOVIE APPEARANCES BY A PROFESSIONAL ENTERTAINER; ENTERTAINMENT SERVICES, NAMELY, PERSONAL APPEARANCES BY A CELEBRITY, POLITICIAN, ARTIST; ENTERTAINMENT SERVICES, NAMELY, PRODUCTION OF SPECIAL EFFECTS INCLUDING MODEL-MAKING SERVICES, COMPUTER-GENERATED IMAGERY AND COMPUTER-GENERATED GRAPHICS FOR THE PRODUCTION OF MOTION PICTURES, VIDEOS, AND MOVIE TRAILERS; ENTERTAINMENT SERVICES, NAMELY, PROVIDING ON-LINE REVIEWS OF MUSIC, MOVIES, BOOKS, GAMES; ENTERTAINMENT SERVICES, NAMELY, THE PROVISION OF CONTINUING PROGRAMS, MOVIES, SHOWS, FEATURING NEWS, COMEDY, DRAMA, COMMENTARY AND ART, DELIVERED BY RADIO, INTERNET, SATELLITE, TELEVISION OR LIVE; MOVIE STUDIOS; PLANNING ARRANGEMENT OF SHOWING MOVIES, SHOWS, PLAYS OR MUSICAL PERFORMANCES; PRODUCTION AND DISTRIBUTION OF TELEVISION SHOWS AND MOVIES; PROVIDING FACILITIES FOR MOVIES, SHOWS, PLAYS, MUSIC OR EDUCATIONAL TRAINING; PROVIDING ONLINE INTERVIEWS FEATURING CELEBRITIES, POLITICIANS, PERSONALITIES IN THE FIELD OF MOVIES, SPORTS, POLITICS, BUSINESS, MEDIA FOR ENTERTAINMENT PURPOSES; RENTAL OF STAGE AND MOVIE EQUIPMENT, NAMELY, CAMERA EQUIPMENT, LIGHTING EQUIPMENT AND GRIP EQUIPMENT; TELEVISION, VIDEO AND MOVIE FILMING SERVICES (U.S. CLS. 100, 101 AND 107).

FIRST USE 12-5-2000; IN COMMERCE 12-5-2009.
FRED CARL, EXAMINING ATTORNEY

SN 85-259,512. MINERVINI PRIVATE ACCESS LLC, NYACK, NY. FILED 3-7-2011.

SPECIFIC ENTRY POINT ANALYSIS

THE MARK CONSISTS OF STANDARD CHARACTERS WITHOUT CLAIM TO ANY PARTICULAR FONT, STYLE, SIZE, OR COLOR.

OWNER OF U.S. REG. NOS. 3,611,730 AND 3,611,731.
FOR EDUCATIONAL SERVICES, NAMELY, CONDUCTING WORKSHOPS, ON-LINE WORKSHOPS, SEMINARS AND TRAINING IN THE FIELD OF FINANCIAL INVESTMENTS; PROVIDING ON-LINE NEWSLETTERS AND NEWSPAPERS IN THE FIELD OF FINANCIAL INFORMATION (U.S. CLS. 100, 101 AND 107).

FIRST USE 8-1-1998; IN COMMERCE 8-1-1998.
DAVID HOFFMAN, EXAMINING ATTORNEY

CLASS 41—(Continued).

SN 85-260,159. TELEVISA, S.A. DE C.V., SANTA FE, MEXICO, FILED 3-7-2011.

COMO DICE EL DICHO

THE MARK CONSISTS OF STANDARD CHARACTERS WITHOUT CLAIM TO ANY PARTICULAR FONT, STYLE, SIZE, OR COLOR.

PRIORITY CLAIMED UNDER SEC. 44(D) ON MEXICO APPLICATION NO. 1134916, FILED 11-17-2010, REG. NO. 1205118, DATED 11-17-2010, EXPIRES 11-17-2020.

THE ENGLISH TRANSLATION OF THE WORDS "COMO DICE EL DICHO" IN THE MARK IS AS THE SAW SAYS.

FOR ENTERTAINMENT SERVICES IN THE NATURE OF A CONTINUING DRAMATIC SHOW BROADCAST OVER THE INTERNET AND AN ONGOING DRAMATIC TELEVISION PROGRAM (U.S. CLS. 100, 101 AND 107).

KATHERINE E. HALMEN, EXAMINING ATTORNEY

SN 85-262,283. BILLABOUT LLC, NEW YORK, NY. FILED 3-9-2011.

Billabout

THE MARK CONSISTS OF STANDARD CHARACTERS WITHOUT CLAIM TO ANY PARTICULAR FONT, STYLE, SIZE, OR COLOR.

FOR PROVIDING AN ONLINE JOURNAL OF ENTERTAINMENT SERVICES FOCUSED ON THE AUSTRALIAN COMMUNITY IN THE U.S., FEATURING COMMENTARY ABOUT INFORMATION ABOUT MERCHANDISE, EVENTS, TRAVEL, ENTERTAINMENT AND SERVICES AVAILABLE IN METROPOLITAN AREAS THROUGHOUT THE U.S. AND IN AUSTRALIA (U.S. CLS. 100, 101 AND 107).

FIRST USE 9-12-2010; IN COMMERCE 12-1-2010.
JANET LEE, EXAMINING ATTORNEY

SN 85-263,174. ROZEFORT, CHRISTOPHER, MARGATE, FL. FILED 3-10-2011.

CHRIS SMOOVE

THE MARK CONSISTS OF STANDARD CHARACTERS WITHOUT CLAIM TO ANY PARTICULAR FONT, STYLE, SIZE, OR COLOR.

THE NAME(S), PORTRAIT(S), AND/OR SIGNATURE(S) SHOWN IN THE MARK IDENTIFIES CHRISTOPHER ROZEFORT, WHOSE CONSENT(S) TO REGISTER IS MADE OF RECORD.

FOR ENTERTAINMENT IN THE NATURE OF LIVE PERFORMANCES BY A MUSICAL ARTIST (U.S. CLS. 100, 101 AND 107).

PAUL MORENO, EXAMINING ATTORNEY

CLASS 41—(Continued).

SN 85-264,414. NELVANA INTERNATIONAL LIMITED, LIMERICK, IRELAND, FILED 3-11-2011.



THE MARK CONSISTS OF THE WORDING "BADOU" IN A STYLIZED FONT. THE COLORS "BLACK", "WHITE" AND "GRAY" REPRESENT OUTLINING AND SHADING AND ARE NOT PART OF THE MARK.

THE WORDING "BADOU" HAS NO MEANING IN A FOREIGN LANGUAGE.

FOR EDUCATIONAL AND ENTERTAINMENT SERVICES, NAMELY, PROVIDING AN ON-GOING SERIES OF ANIMATED PROGRAMS PROVIDED VIA TELEVISION, A GLOBAL COMPUTER NETWORK, MOBILE COMPUTERS, MEDIA PLAYERS, CELLULAR PHONES, WIRELESS DEVICES, AND PORTABLE AND HAND-HELD DIGITAL ELECTRONIC DEVICES (U.S. CLS. 100, 101 AND 107).

RENEE MCCRAY, EXAMINING ATTORNEY

SN 85-265,088. GEORGIA CREDIT UNION AFFILIATES, INC., DULUTH, GA. FILED 3-11-2011.

CONSIDER THIS ...

THE MARK CONSISTS OF STANDARD CHARACTERS WITHOUT CLAIM TO ANY PARTICULAR FONT, STYLE, SIZE, OR COLOR.

FOR NON DOWNLOADABLE ELECTRONIC PUBLICATIONS IN THE NATURE OF NEWS BRIEFS IN THE FIELD OF FINANCE AND CONSUMER ISSUES AND INFORMATION (U.S. CLS. 100, 101 AND 107).

FIRST USE 2-0-2010; IN COMMERCE 2-0-2010.
SUSAN RICHARDS, EXAMINING ATTORNEY

SN 85-265,360. INTER COASTAL COPIERS, DBA SARASOTA GOLD, SARASOTA, FL. FILED 3-12-2011.

Sarasota Gold

THE MARK CONSISTS OF STANDARD CHARACTERS WITHOUT CLAIM TO ANY PARTICULAR FONT, STYLE, SIZE, OR COLOR.

NO CLAIM IS MADE TO THE EXCLUSIVE RIGHT TO USE "SARASOTA", APART FROM THE MARK AS SHOWN.

FOR ENTERTAINMENT SERVICES IN THE NATURE OF PRESENTING LIVE MUSICAL PERFORMANCES (U.S. CLS. 100, 101 AND 107).

FIRST USE 10-20-2008; IN COMMERCE 10-20-2008.
AMY C. KEAN, EXAMINING ATTORNEY

CLASS 41—(Continued).

SN 85-265,451. FOXX, JT, IRVINE, CA. FILED 3-12-2011.

Mega Partnering

THE MARK CONSISTS OF STANDARD CHARACTERS WITHOUT CLAIM TO ANY PARTICULAR FONT, STYLE, SIZE, OR COLOR.

FOR ARRANGING AND CONDUCTING BUSINESS SEMINARS IN THE FIELD OF REAL ESTATE INVESTING (U.S. CLS. 100, 101 AND 107).

FIRST USE 3-1-2010; IN COMMERCE 3-1-2010.
JAMES A. RAUEN, EXAMINING ATTORNEY

SN 85-265,868. MURRAY DRANOFF FOUNDATION, INC., MIAMI, FL. FILED 3-14-2011.

PIANO SLAM

THE MARK CONSISTS OF STANDARD CHARACTERS WITHOUT CLAIM TO ANY PARTICULAR FONT, STYLE, SIZE, OR COLOR.

NO CLAIM IS MADE TO THE EXCLUSIVE RIGHT TO USE "PIANO", APART FROM THE MARK AS SHOWN.

FOR MUSICAL PERFORMANCE AND EDUCATION PROGRAM, NAMELY, APPEARANCES BY AWARD WINNING PIANISTS RENOWNED POETS AND SPOKEN WORD ARTISTS IN PUBLIC MIDDLE AND HIGH SCHOOLS DELIVERED LIVE OR VIA THE INTERNET (U.S. CLS. 100, 101 AND 107).

FIRST USE 1-31-2009; IN COMMERCE 1-31-2009.
BARBARA BROWN, EXAMINING ATTORNEY

SN 85-266,674. PREDICTIONMACHINE.COM, LLC, LAS VEGAS, NV. FILED 3-14-2011.

PREDICTIONMACHINE

THE MARK CONSISTS OF STANDARD CHARACTERS WITHOUT CLAIM TO ANY PARTICULAR FONT, STYLE, SIZE, OR COLOR.

FOR PROVIDING AN ONLINE WEBSITE FEATURING SPORTS-RELATED STATISTICAL ANALYSIS INFORMATION AND SPORTS INFORMATION (U.S. CLS. 100, 101 AND 107).

FIRST USE 1-27-2010; IN COMMERCE 1-27-2010.
LINDA LAVACHE, EXAMINING ATTORNEY

CLASS 41—(Continued).

SN 85-266,870. SIMS, DINO, ATLANTA, GA. FILED 3-15-2011.

NEW SCHOOL NETWORKER

THE MARK CONSISTS OF STANDARD CHARACTERS WITHOUT CLAIM TO ANY PARTICULAR FONT, STYLE, SIZE, OR COLOR.

NO CLAIM IS MADE TO THE EXCLUSIVE RIGHT TO USE "NETWORKER", APART FROM THE MARK AS SHOWN.

FOR EDUCATION SERVICES, NAMELY, PROVIDING ON-LINE AND ON-SITE CLASSES AND INSTRUCTION IN THE FIELD OF COMPUTER, AND TECHNOLOGY TRAINING WITH SPECIAL EMPHASIS ON SALES AND MARKETING (U.S. CLS. 100, 101 AND 107).

BARBARA RUTLAND, EXAMINING ATTORNEY

SN 85-267,056. MURRAY DRANOFF FOUNDATION, INC., MIAMI, FL. FILED 3-15-2011.



NO CLAIM IS MADE TO THE EXCLUSIVE RIGHT TO USE "PIANO", APART FROM THE MARK AS SHOWN.

THE MARK CONSISTS OF THE STYLIZED PHRASE "PIANO SLAM" WITH RAISED LETTERING.

FOR MUSICAL PERFORMANCE AND EDUCATION PROGRAM, NAMELY, APPEARANCES BY AWARD WINNING PIANISTS RENOWNED POETS AND SPOKEN WORD ARTISTS IN PUBLIC MIDDLE AND HIGH SCHOOLS DELIVERED LIVE OR VIA THE INTERNET (U.S. CLS. 100, 101 AND 107).

FIRST USE 2-20-2011; IN COMMERCE 2-20-2011.

BARBARA BROWN, EXAMINING ATTORNEY

SN 85-267,108. JENNIFER WESTON, ISLAND PARK, NY. FILED 3-15-2011.

WALK WITH ME

THE MARK CONSISTS OF STANDARD CHARACTERS WITHOUT CLAIM TO ANY PARTICULAR FONT, STYLE, SIZE, OR COLOR.

FOR PROVIDING AN INTERACTIVE WEBSITE FEATURING INFORMATION ABOUT EXERCISE AND FITNESS EVENTS SUCH AS WALKS, RUNS, RACES AND THE LIKE THAT ALSO ENABLES USERS TO REGISTER TO PARTICIPATE IN SUCH EVENTS FOR FITNESS AND ENTERTAINMENT PURPOSES AND TO FIND OTHER SUCH EVENTS IN THEIR AREAS, AND FEATURING LINKS TO EXERCISE AND FITNESS WEBSITES (U.S. CLS. 100, 101 AND 107).

FIRST USE 1-3-2011; IN COMMERCE 1-3-2011.

ELISSA GARBER KON, EXAMINING ATTORNEY

CLASS 41—(Continued).

SN 85-267,303. DÉSILETS, ELISABETH, KIHEI, HI. FILED 3-15-2011.

SEX SAVVY WOMAN

THE MARK CONSISTS OF STANDARD CHARACTERS WITHOUT CLAIM TO ANY PARTICULAR FONT, STYLE, SIZE, OR COLOR.

NO CLAIM IS MADE TO THE EXCLUSIVE RIGHT TO USE "SEX" AND "WOMAN", APART FROM THE MARK AS SHOWN.

FOR EDUCATION SERVICES, NAMELY, CONDUCTING SEMINARS, CONFERENCES, WORKSHOPS AND ONLINE COURSES IN THE FIELD OF SEXUALITY AND PSYCHOLOGICAL HEALTH AND WELL-BEING (U.S. CLS. 100, 101 AND 107).

MARK SPARACINO, EXAMINING ATTORNEY

SN 85-267,765. RAMANAN, SHRIPRIYA MAHESH, NEW YORK, NY. FILED 3-15-2011.



THE MARK CONSISTS OF THE STYLIZED TEXT "TATVAM" WITH A SWOOSH RUNNING ACROSS THE LETTERS.

THE ENGLISH TRANSLATION OF "TATVAM" IN THE MARK IS "REALITY" OR "TRUTH".

FOR CINEMATOGRAPHIC ADAPTATION AND EDITING; ENTERTAINMENT AND EDUCATIONAL SERVICES, NAMELY, PROVIDING ADVICE AND INFORMATION FOR MUSIC, VIDEO AND FILM CONCEPT AND SCRIPT DEVELOPMENT; ENTERTAINMENT SERVICES, NAMELY, PROVIDING ON-LINE REVIEWS OF MOVIES; FILM AND VIDEO PRODUCTION; FILM AND VIDEO PRODUCTION CONSULTING SERVICES; FILM EDITING; ON-LINE JOURNALS, NAMELY, BLOGS FEATURING FILMS, FILMMAKING, SCRIPT WRITING, EDITING, FILM PRODUCTION; PRODUCTION OF FILMS; SCRIPT WRITING SERVICES (U.S. CLS. 100, 101 AND 107).

FIRST USE 11-0-2005; IN COMMERCE 10-0-2006.

CAROLINE WOOD, EXAMINING ATTORNEY

CLASS 41—(Continued).

SN 85-268,072. DUSTER'S OFF-ROAD CLUB, INC., COPEMISH, MI. FILED 3-16-2011.

DOG PARTY

THE MARK CONSISTS OF STANDARD CHARACTERS WITHOUT CLAIM TO ANY PARTICULAR FONT, STYLE, SIZE, OR COLOR.

NO CLAIM IS MADE TO THE EXCLUSIVE RIGHT TO USE "PARTY", APART FROM THE MARK AS SHOWN.

FOR ENTERTAINMENT SERVICES IN THE WAY OF FOUR-WHEEL DRIVE EVENTS AND FESTIVALS (U.S. CLS. 100, 101 AND 107).

FIRST USE 2-28-1981; IN COMMERCE 2-28-1981.
LINDSEY RUBIN, EXAMINING ATTORNEY

SN 85-268,538. DRAKE-MCLAUGHLIN, MIGUEL, BROOKLYN, NY, AND SELKOWITZ, ADRIAN A, HARRISBURG, PA. FILED 3-16-2011.

TR Films

THE MARK CONSISTS OF STANDARD CHARACTERS WITHOUT CLAIM TO ANY PARTICULAR FONT, STYLE, SIZE, OR COLOR.

NO CLAIM IS MADE TO THE EXCLUSIVE RIGHT TO USE "FILMS", APART FROM THE MARK AS SHOWN.

FOR ENTERTAINMENT MEDIA PRODUCTION SERVICES FOR MOTION PICTURES, TELEVISION AND INTERNET; FILM AND VIDEO PRODUCTION; FILM AND VIDEO PRODUCTION CONSULTING SERVICES; MOTION PICTURE FILM PRODUCTION; MUSIC VIDEO PRODUCTION; PRODUCTION AND DISTRIBUTION OF INDEPENDENT MOTION PICTURES; PRODUCTION AND DISTRIBUTION OF MOTION PICTURES; VIDEO PRODUCTION SERVICES (U.S. CLS. 100, 101 AND 107).

FIRST USE 6-1-1998; IN COMMERCE 11-11-2004.
THEODORE MCBRIDE, EXAMINING ATTORNEY

CLASS 41—(Continued).

SN 85-268,912. JENNEN, GREGORY, TWO RIVERS, AK. FILED 3-16-2011.



THE COLOR(S) YELLOW, MAROON, BLACK, GRAY, WHITE AND BROWN IS/ARE CLAIMED AS A FEATURE OF THE MARK.

THE MARK CONSISTS OF THE WORD "GRIZZINATOR" IN YELLOW AND BROWN WITH AN UPPER PORTION OF A GRIZZLY BEAR IN BROWN, GRAY AND BLACK WITH A MAROON TONGUE AND WHITE TEETH, NEXT TO THE GRIZZLY BEAR IS WHITE AND GRAY SNOW AND THE GRIZZLY BEAR HAS A WHITE, GRAY AND BLACK PAW.

FOR HUNTING GUIDE SERVICES; PROVIDING A WEBSITE FEATURING INFORMATION ABOUT HUNTING (U.S. CLS. 100, 101 AND 107).

CHARLES L. JENKINS, EXAMINING ATTORNEY

SN 85-269,080. LITTLE LINGUISTS, INC., MURRYSVILLE, PA. FILED 3-16-2011.

Little Linguists

THE MARK CONSISTS OF STANDARD CHARACTERS WITHOUT CLAIM TO ANY PARTICULAR FONT, STYLE, SIZE, OR COLOR.

NO CLAIM IS MADE TO THE EXCLUSIVE RIGHT TO USE "LINGUISTS", APART FROM THE MARK AS SHOWN.

FOR FOREIGN LANGUAGE INSTRUCTION SERVICES (U.S. CLS. 100, 101 AND 107).
FIRST USE 9-29-2002; IN COMMERCE 4-11-2004.
KARANENDRA S. CHHINA, EXAMINING ATTORNEY

CLASS 41—(Continued).

SN 85-269,151. WHISPERART MINISTRY, MADISON, AL.
FILED 3-17-2011.

WHISPERART MEDIA
PRODUCTIONS

THE MARK CONSISTS OF STANDARD CHARACTERS WITHOUT CLAIM TO ANY PARTICULAR FONT, STYLE, SIZE, OR COLOR.

NO CLAIM IS MADE TO THE EXCLUSIVE RIGHT TO USE "MEDIA PRODUCTIONS", APART FROM THE MARK AS SHOWN.

FOR MUSIC COMPOSITION SERVICES; EDUCATIONAL AND ENTERTAINMENT SERVICES IN THE NATURE OF CREATING AND COMPOSING INSPIRATION ARTWORK, POETRY, DEVOTIONALS, MUSIC AND LYRICS FOR OTHERS (U.S. CLS. 100, 101 AND 107).

KARANENDRA S. CHHINA, EXAMINING ATTORNEY

CLASS 41—(Continued).

SN 85-269,343. THE FLYING TOASTERS, INC., CICERO, IN.
FILED 3-17-2011.



THE COLOR(S) GRAY, WHITE, BLUE, LIGHT TAN, DARK TAN AND BLACK IS/ARE CLAIMED AS A FEATURE OF THE MARK.

THE MARK CONSISTS OF "THE" POSITIONED VERTICALLY ABOVE THE WORDS "FLYING TOASTERS" IN THE COLOR BLACK WITH A STYLIZED DRAWING OF A BLUE, WHITE AND DARK TAN TOASTER WITH LIGHT TAN AND DARK TAN TOAST IN EACH OPENING OF THE TOASTER WITH GRAY AIRPLANE WINGS WITH PROPELLER ON EACH WING IN THE COLOR WHITE AND A GRAY RUDDER ON THE TOASTER.

FOR ENTERTAINMENT SERVICES IN THE NATURE OF LIVE MUSICAL PERFORMANCES (U.S. CLS. 100, 101 AND 107).

FIRST USE 3-24-2004; IN COMMERCE 3-24-2004.
ANNE E. GUSTASON, EXAMINING ATTORNEY

SN 85-269,180. NEW YORK MEDIA, LLC, NEW YORK, NY.
FILED 3-17-2011.

VULTURE'S ANTICIPATION
INDEX

THE MARK CONSISTS OF STANDARD CHARACTERS WITHOUT CLAIM TO ANY PARTICULAR FONT, STYLE, SIZE, OR COLOR.

OWNER OF U.S. REG. NO. 3,368,526.

NO CLAIM IS MADE TO THE EXCLUSIVE RIGHT TO USE "ANTICIPATION INDEX", APART FROM THE MARK AS SHOWN.

FOR PROVIDING ONLINE INFORMATION IN THE FIELDS OF ENTERTAINMENT AND POPULAR CULTURE (U.S. CLS. 100, 101 AND 107).

FIRST USE 2-25-2011; IN COMMERCE 2-25-2011.
MICHAEL GAFFAR, EXAMINING ATTORNEY

SN 85-269,519. THE PAINT BAR LLC, NEWTON, MA. FILED
3-17-2011.

THE PAINT BAR

THE MARK CONSISTS OF STANDARD CHARACTERS WITHOUT CLAIM TO ANY PARTICULAR FONT, STYLE, SIZE, OR COLOR.

NO CLAIM IS MADE TO THE EXCLUSIVE RIGHT TO USE "PAINT", APART FROM THE MARK AS SHOWN.

FOR PROVIDING FACILITIES FOR ART STUDIOS; EDUCATIONAL AND ENTERTAINMENT SERVICES, NAMELY, PROVIDING ART INSTRUCTION AND ART ACTIVITIES, NAMELY, ART AND PAINTING CLASSES (U.S. CLS. 100, 101 AND 107).

FIRST USE 11-30-2010; IN COMMERCE 11-30-2010.
LOURDES AYALA, EXAMINING ATTORNEY

CLASS 41—(Continued).

SN 85-269,964. HOWARD COUNTY STRIDERS INC., CO-LUMBIA, MD. FILED 3-17-2011.



THE MARK CONSISTS OF THE WORDING "THE NEXT STEP" AT THE TOP OF A RUNNING SHOE FILLED WITH SMALL RUNNER SILHOUETTES, AND WITH TWO CURVED SHAPES CASCADING DOWN FROM THE "S" IN "STEP". THERE IS ONE RUNNER IN THE OPPOSITE DIRECTION ABOVE THE "E" IN "STEP."

FOR TRAINING MEMBERS OF THE HOWARD COUNTY STRIDERS RUNNING CLUB IN THE FIELD OF COMPETITIVE RUNNING (U.S. CLS. 100, 101 AND 107).

FIRST USE 2-2-2004; IN COMMERCE 2-2-2004.
ROBIN CHOSID, EXAMINING ATTORNEY

CLASS 41—(Continued).

SN 85-270,559. FOTL, LLC, PHILADELPHIA, PA. FILED 3-18-2011.

FRONTOTHELIN.COM

THE MARK CONSISTS OF STANDARD CHARACTERS WITHOUT CLAIM TO ANY PARTICULAR FONT, STYLE, SIZE, OR COLOR.

FOR ON-LINE ENTERTAINMENT TICKET AGENCY SERVICES FOR PROVIDING SPECIAL ACCESS TO NIGHTCLUBS (U.S. CLS. 100, 101 AND 107).
DAVID COLLIER, EXAMINING ATTORNEY

SN 85-270,763. PARKS, JONATHAN, MARINA DEL REY, CA. FILED 3-18-2011.

SN 85-270,269. WILSON, KALILIA D., WASHINGTON, DC. FILED 3-17-2011.



THE COLOR(S) PURPLE, BLUE, BROWN, GREEN, PINK, RED, WHITE AND GOLD IS/ARE CLAIMED AS A FEATURE OF THE MARK.

THE MARK CONSISTS OF A STYLIZED EARTH IN THE SHAPE OF A HEART WITH GREEN, BROWN AND BLUE COLORS ADORNED WITH DIAMOND SPECS IN THE COLOR WHITE; A GOLD CROWN WITH PINK, RED AND GREEN ORNAMENTS, WHITE PEARLS AND A WHITE DIAMOND-STUDDED LETTER "H" AT THE CENTER SITS ON THE HEAD OF THE EARTH; THE STYLIZED WORDING "HEIRESS WORLD" IN THE COLOR PURPLE FORMS THE BASE OF THE EARTH FOLLOWED BY THE WORDS "PEACE. LOVE. HOPE" IN GOLD.

FOR ENTERTAINMENT IN THE NATURE OF LIVE PERFORMANCES BY MUSICAL GROUP; ENTERTAINMENT IN THE NATURE OF VISUAL AND AUDIO PERFORMANCES BY MUSICAL GROUP (U.S. CLS. 100, 101 AND 107).

FIRST USE 1-6-2011; IN COMMERCE 1-6-2011.
B. PARADEWELAI, EXAMINING ATTORNEY



THE COLOR(S) BLACK, ORANGE, YELLOW, AND BROWN IS/ARE CLAIMED AS A FEATURE OF THE MARK.

THE MARK CONSISTS OF AN ORANGE SQUARE WITH ORANGE ARMS AND LEGS, BLACK EYES WITH ORANGE EYEBALLS, AND A BLACK MOUTH WITH "ALIBI" WRITTEN IN THE MOUTH IN ORANGE WITH A BLACK LINE THROUGH THE WORDING; A SPOTLIGHT LIGHT IS ON THE UPPER LEFT CORNER OF THE SQUARE CREATING A YELLOW SHINE ON THE UPPER LEFT CORNER OF THE SQUARE AND ITS LEFT HAND, A BROWN HALO BEHIND THE LEFT SIDE OF THE SQUARE, AND A BLACK SHADOW BEHIND THE RIGHT SIDE OF THE SQUARE. THE COLOR BROWN APPEARS AS SHADING IN THE EYES AND MOUTH. THE BACKGROUND OF THE MARK IS TRANSPARENT.

FOR PROVIDING A MUSIC LIBRARY OF MUSIC FOR LICENSING TO FILM-MAKERS, VIDEO PRODUCERS, AND TV PRODUCERS FOR USE IN THEIR PRODUCTIONS; COMPOSITION OF MUSIC FOR OTHERS, MUSIC PRODUCTION AND RECORDING STUDIO SERVICES FOR ENTERTAINMENT COMPANIES AND ADVERTISERS (U.S. CLS. 100, 101 AND 107).

FIRST USE 8-9-2010; IN COMMERCE 1-6-2011.
ANDREA HACK, EXAMINING ATTORNEY

CLASS 41—(Continued).

SN 85-270,779. REECE, STEPHEN, NAMPA, ID. FILED 3-18-2011.

Almost Athiest†

NO CLAIM IS MADE TO THE EXCLUSIVE RIGHT TO USE "ATHEIST", APART FROM THE MARK AS SHOWN.

THE MARK CONSISTS OF THE STYLIZED WORDING "ALMOST ATHIEST" WITH THE LAST "T" IN THE WORD "ATHIEST" DEPICTED AS A CROSS.

FOR ON-LINE JOURNALS, NAMELY, BLOGS FEATURING DISCUSSIONS ABOUT RELIGION AND PHILOSOPHY (U.S. CLS. 100, 101 AND 107).

EVELYN BRADLEY, EXAMINING ATTORNEY

SN 85-271,132. WYCLIFFE BIBLE TRANSLATORS INTERNATIONAL, INC., DBA WYCLIFFE GLOBAL ALLIANCE, DALLAS, TX. FILED 3-18-2011.

Wycliffe Global Alliance

THE MARK CONSISTS OF STANDARD CHARACTERS WITHOUT CLAIM TO ANY PARTICULAR FONT, STYLE, SIZE, OR COLOR.

OWNER OF U.S. REG. NOS. 2,619,817, 2,777,008 AND OTHERS.

NO CLAIM IS MADE TO THE EXCLUSIVE RIGHT TO USE "GLOBAL ALLIANCE", APART FROM THE MARK AS SHOWN.

FOR LANGUAGE TRANSLATION (U.S. CLS. 100, 101 AND 107).

FIRST USE 2-1-2011; IN COMMERCE 2-1-2011.
KIMBERLY FRYE, EXAMINING ATTORNEY

SN 85-271,151. WYCLIFFE BIBLE TRANSLATORS INTERNATIONAL, INC., DBA WYCLIFFE GLOBAL ALLIANCE, DALLAS, TX. FILED 3-18-2011.

**Wycliffe Global Alliance
Partners in Bible
translation**

THE MARK CONSISTS OF STANDARD CHARACTERS WITHOUT CLAIM TO ANY PARTICULAR FONT, STYLE, SIZE, OR COLOR.

OWNER OF U.S. REG. NOS. 2,619,817, 2,777,008 AND OTHERS.

NO CLAIM IS MADE TO THE EXCLUSIVE RIGHT TO USE "GLOBAL ALLIANCE PARTNERS IN BIBLE TRANSLATION", APART FROM THE MARK AS SHOWN.

FOR LANGUAGE TRANSLATION (U.S. CLS. 100, 101 AND 107).

FIRST USE 3-1-2011; IN COMMERCE 3-1-2011.
KIMBERLY FRYE, EXAMINING ATTORNEY

CLASS 41—(Continued).

SN 85-271,308. WEATHERHOLT & ASSOCIATES, LLC, ANCHORAGE, AK. FILED 3-18-2011.

**Getting
Down to
Business**

THE MARK CONSISTS OF THE LITERAL ELEMENT "GETTING DOWN TO BUSINESS" AND A DESIGN ELEMENT CONSISTING OF THE GRAPHIC STYLIZED REPRESENTATION OF A DOLLAR SIGN SUPERIMPOSED UPON A RECTANGLE WHOSE CORNERS ARE ROUNDED, AND WHEREIN THE WORD "GETTING" IS LOCATED ABOVE THE WORDS "DOWN TO" WHICH ARE LOCATED ABOVE THE WORD "BUSINESS", AND WHEREIN FURTHER, THE LITERAL ELEMENT IS LOCATED TO THE RIGHT OF THE DESIGN ELEMENT.

FOR ENTERTAINMENT SERVICES, NAMELY, THE PROVISION OF CONTINUING TALK SHOWS FEATURING BUSINESS NEWS, COMMENTARY AND ADVICE DELIVERED BY RADIO, TELEVISION, GLOBAL COMPUTER NETWORKS AND PODCASTS (U.S. CLS. 100, 101 AND 107).

FIRST USE 5-19-2009; IN COMMERCE 5-19-2009.
CHARLES L. JENKINS, EXAMINING ATTORNEY

SN 85-271,389. THELUSMA, ROBERT, LOS ANGELES, CA. FILED 3-18-2011.

**AFFIRMATIVE
ATHLETICS**

NO CLAIM IS MADE TO THE EXCLUSIVE RIGHT TO USE "ATHLETICS", APART FROM THE MARK AS SHOWN.

THE MARK CONSISTS OF A BIG LETTER "A" WITH WINGS WITH "AFFIRMATIVE ATHLETICS" WRITTEN UNDERNEATH.

FOR PROVIDING AFTER SCHOOL ATHLETIC PROGRAMS (U.S. CLS. 100, 101 AND 107).

FIRST USE 1-1-2008; IN COMMERCE 1-1-2008.
MICHAEL KEATING, EXAMINING ATTORNEY

CLASS 41—(Continued).

SN 85-271,472. POMAJAMBO, SHANE, GREAT FALLS, VA.
FILED 3-19-2011.

ART WHINO

THE MARK CONSISTS OF STANDARD CHARACTERS WITHOUT CLAIM TO ANY PARTICULAR FONT, STYLE, SIZE, OR COLOR.

NO CLAIM IS MADE TO THE EXCLUSIVE RIGHT TO USE "ART", APART FROM THE MARK AS SHOWN.
FOR ART EXHIBITIONS (U.S. CLS. 100, 101 AND 107).
FIRST USE 1-1-2011; IN COMMERCE 1-1-2011.
LESLIE RICHARDS, EXAMINING ATTORNEY

SN 85-271,573. K. RAPIER'S KIDS, SAN ANTONIO, TX.
FILED 3-19-2011.



NO CLAIM IS MADE TO THE EXCLUSIVE RIGHT TO USE "KIDS OF SAN ANTONIO", APART FROM THE MARK AS SHOWN.

THE MARK CONSISTS OF THE DESIGN OF TWO OPEN BOOKS BEHIND THE NAME "KYM'S". THE WORDING "KIDS OF SAN ANTONIO" IS TO THE RIGHT OF THE DESIGN. THE WORDING "EARNING A FUTURE THROUGH SERVICE TODAY" APPEARS BELOW.

FOR ARRANGING AND CONDUCTING AWARD PROGRAMS FOR YOUTH TO PERFORM COMMUNITY SERVICE IN EXCHANGE FOR FUNDS FOR COLLEGE, MILITARY SERVICE OR VOCATIONAL SCHOOL (U.S. CLS. 100, 101 AND 107).
H. M. FISHER, EXAMINING ATTORNEY

CLASS 41—(Continued).

SN 85-272,195. FTNS LLC, NORWALK, CT. FILED 3-21-2011.



NO CLAIM IS MADE TO THE EXCLUSIVE RIGHT TO USE "FITNESS RADIO", APART FROM THE MARK AS SHOWN.

THE COLOR(S) RED AND WHITE IS/ARE CLAIMED AS A FEATURE OF THE MARK.

THE MARK CONSISTS OF THE LETTERS "FTNS" IN WHITE WITH A RED OUTLINE OVER A RED SPEECH BUBBLE WITH THE WORDS "FITNESS RADIO" IN WHITE.

FOR PROVIDING A WEB SITE FEATURING INFORMATION ON EXERCISE AND FITNESS; PROVIDING A WEBSITE FEATURING INFORMATION ON EXERCISE AND FITNESS; PROVIDING AN INTERACTIVE WEBSITE FEATURING INFORMATION AND LINKS RELATING TO FITNESS; PROVIDING AN ON-LINE COMPUTER DATABASE FEATURING INFORMATION REGARDING EXERCISE AND FITNESS (U.S. CLS. 100, 101 AND 107).

FIRST USE 7-1-2010; IN COMMERCE 7-1-2010.
NORA BUCHANAN WILL, EXAMINING ATTORNEY

SN 85-272,218. INTERNET TESTING SYSTEMS, LLC, BALTIMORE, MD. FILED 3-21-2011.

Promise Learning

THE MARK CONSISTS OF STANDARD CHARACTERS WITHOUT CLAIM TO ANY PARTICULAR FONT, STYLE, SIZE, OR COLOR.

OWNER OF U.S. REG. NO. 3,962,864.
NO CLAIM IS MADE TO THE EXCLUSIVE RIGHT TO USE "LEARNING", APART FROM THE MARK AS SHOWN.
FOR EDUCATIONAL TESTING (U.S. CLS. 100, 101 AND 107).

FIRST USE 12-8-2010; IN COMMERCE 1-31-2011.
KIM SAITO, EXAMINING ATTORNEY

CLASS 41—(Continued).

SN 85-272,537. VIRGO PUBLISHING, LLC, PHOENIX, AZ. FILED 3-21-2011.

CHARTER SCHOOLS INSIDER

THE MARK CONSISTS OF STANDARD CHARACTERS WITHOUT CLAIM TO ANY PARTICULAR FONT, STYLE, SIZE, OR COLOR.

NO CLAIM IS MADE TO THE EXCLUSIVE RIGHT TO USE "CHARTER SCHOOLS", APART FROM THE MARK AS SHOWN.

FOR PROVIDING ON-LINE NON-DOWNLOADABLE PUBLICATIONS, NAMELY, JOURNALS, MAGAZINES, NEWSLETTERS, AND BLOGS IN THE FIELD OF CHARTER SCHOOL INVESTING, DEVELOPMENT, CURRICULUM, RECRUITMENT, OPERATION AND ASSESSMENT; EDUCATION SERVICES, NAMELY, PROVIDING ONLINE SEMINARS IN THE FIELD OF CHARTER SCHOOL INVESTING, DEVELOPMENT, CURRICULUM, RECRUITMENT, OPERATION AND ASSESSMENT; PROVIDING INFORMATION ON CHARTER SCHOOL CURRICULA AND RANKINGS VIA E-MAIL (U.S. CLS. 100, 101 AND 107).

FIRST USE 3-14-2011; IN COMMERCE 3-14-2011.

MATTHEW MCDOWELL, EXAMINING ATTORNEY

CLASS 41—(Continued).

SN 85-272,858. MATT OLMSTEAD PRODUCTIONS, INC., SANTA MONICA, CA. FILED 3-21-2011.

The logo for Matt Olmstead Productions features the name "MATT OLMSTEAD" in a bold, black, sans-serif font. Below the name, the word "PRODUCTIONS" is written in a smaller, spaced-out, black, sans-serif font.

NO CLAIM IS MADE TO THE EXCLUSIVE RIGHT TO USE "PRODUCTIONS", APART FROM THE MARK AS SHOWN.

THE NAME "MATT OLMSTEAD" IDENTIFIES A LIVING INDIVIDUAL WHOSE CONSENT IS OF RECORD.

THE MARK CONSISTS OF "MATT OLMSTEAD" (CHAMPION BANTAMWEIGHT FONT) "PRODUCTIONS" (CHAMPION MIDDLEWEIGHT FONT) IN CAPITAL LETTERS. "MATT OLMSTEAD" IS ON ONE LINE, WHILE "PRODUCTIONS" IS IN SMALLER TYPE ON THE LINE BELOW IT.

FOR CREATION AND PRODUCTION OF TELEVISION, FILM, AND THEATRICAL PRODUCTIONS (U.S. CLS. 100, 101 AND 107).

ARETHA SOMERVILLE, EXAMINING ATTORNEY

SN 85-272,553. FTNS LLC, NORWALK, CT. FILED 3-21-2011.

The logo for FTNS consists of the letters "FTNS" in a bold, stylized, blocky font. The letters are white with a thick black outline, giving them a three-dimensional appearance.

THE MARK CONSISTS OF THE LETTERS "FTNS" SHOWN IN STYLIZED BLOCK LETTERS GIVING A THREE-DIMENSIONAL LIKE APPEARANCE.

FOR PROVIDING A WEB SITE FEATURING INFORMATION ON EXERCISE AND FITNESS; PROVIDING A WEBSITE FEATURING INFORMATION ON EXERCISE AND FITNESS; PROVIDING AN INTERACTIVE WEBSITE FEATURING INFORMATION AND LINKS RELATING TO FITNESS; PROVIDING AN ON-LINE COMPUTER DATABASE FEATURING INFORMATION REGARDING EXERCISE AND FITNESS (U.S. CLS. 100, 101 AND 107).

FIRST USE 7-1-2010; IN COMMERCE 7-1-2010.

NORA BUCHANAN WILL, EXAMINING ATTORNEY

SN 85-272,931. HANSEN, GWENDA GARRISON, DBA BE BAD HIP HOP, FORT COLLINS, CO. FILED 3-22-2011.



NO CLAIM IS MADE TO THE EXCLUSIVE RIGHT TO USE "HIP HOP", APART FROM THE MARK AS SHOWN.

THE COLOR(S) RED AND BLACK IS/ARE CLAIMED AS A FEATURE OF THE MARK.

THE MARK CONSISTS OF RED LIPS WITH A BLACK SKULL AND CROSS BONES SUPERIMPOSED OVER THE RIGHT SIDE OF THE LIPS ABOVE THE STYLIZED RED WORDS "BE BAD HIP HOP" OUTLINED IN BLACK.

FOR DANCE INSTRUCTION (U.S. CLS. 100, 101 AND 107).

FIRST USE 3-1-2011; IN COMMERCE 3-1-2011.

DAVID TOOLEY, EXAMINING ATTORNEY

CLASS 41—(Continued).

SN 85-273,199. REHOBOTH ROUNDUP ORG. CORP., REHOBOTH BEACH, DE. FILED 3-22-2011.



NO CLAIM IS MADE TO THE EXCLUSIVE RIGHT TO USE "REHOBOTH", APART FROM THE MARK AS SHOWN. THE MARK CONSISTS OF THE STYLIZED TEXT "SPIRIT BY THE SEA REHOBOTH ROUNDUP" WITH A WAVE OVERLAYING THE TEXT "SPIRIT".

FOR EDUCATIONAL SERVICES, NAMELY, CONDUCTING CONFERENCES IN THE FIELD OF 12 STEP RECOVERY FOR THE GAY, LESBIAN, BISEXUAL AND TRANSGENDERED (GLBT) COMMUNITY (U.S. CLS. 100, 101 AND 107).

FIRST USE 10-27-2002; IN COMMERCE 2-15-2003.
HEATHER THOMPSON, EXAMINING ATTORNEY

SN 85-273,232. THE SPORTSMAN CHANNEL, INC., NEW BERLIN, WI. FILED 3-22-2011.



NO CLAIM IS MADE TO THE EXCLUSIVE RIGHT TO USE "HD", APART FROM THE MARK AS SHOWN.

THE MARK CONSISTS OF THE WORDS "SPORTSMAN HD" AND 3 CIRCLES TO THE LEFT OF "HD". EACH CIRCLE CONTAINS A SECOND INTERIOR CIRCLE AND A DESIGN ELEMENT. THE FIRST IS THE OUTLINE OF AN ANTLER, THE SECOND A STYLIZED TARGET AND THE THIRD A SWIMMING FISH.

FOR PRODUCTION AND DISTRIBUTION OF VIDEO RECORDINGS AND TELEVISION PROGRAMS FEATURING HUNTING, SHOOTING, FISHING, FIREARMS AND OUTDOOR ACTIVITIES; ENTERTAINMENT IN THE NATURE OF ON-GOING TELEVISION PROGRAMS IN THE FIELDS OF HUNTING, SHOOTING, FISHING, FIREARMS AND OUTDOOR ACTIVITIES; ENTERTAINMENT SERVICES, NAMELY, PROVIDING ON-GOING VIDEO PROGRAMS IN THE FIELDS OF HUNTING, SHOOTING, FISHING, FIREARMS AND OUTDOOR ACTIVITIES VIA A GLOBAL COMPUTER NETWORK (U.S. CLS. 100, 101 AND 107).

FIRST USE 1-27-2010; IN COMMERCE 1-27-2010.
MORGAN WYNNE, EXAMINING ATTORNEY

CLASS 41—(Continued).

SN 85-273,243. FOTL, LLC, PHILADELPHIA, PA. FILED 3-22-2011.

LINE ROCKET

THE MARK CONSISTS OF STANDARD CHARACTERS WITHOUT CLAIM TO ANY PARTICULAR FONT, STYLE, SIZE, OR COLOR.

NO CLAIM IS MADE TO THE EXCLUSIVE RIGHT TO USE "LINE", APART FROM THE MARK AS SHOWN.

FOR ON-LINE ENTERTAINMENT TICKET AGENCY SERVICES FOR PROVIDING SPECIAL ACCESS TO NIGHTCLUBS (U.S. CLS. 100, 101 AND 107).
DAVID COLLIER, EXAMINING ATTORNEY

SN 85-273,432. SIRUS A. FERDOWS FOR ESCAPADE HOUSTON CORP., HOUSTON, TX. FILED 3-22-2011.



NO CLAIM IS MADE TO THE EXCLUSIVE RIGHT TO USE "2001", APART FROM THE MARK AS SHOWN.

THE COLOR(S) PURPLE, BLACK AND WHITE IS/ARE CLAIMED AS A FEATURE OF THE MARK.

THE MARK CONSISTS OF THE STYLIZED WORDING "ESCAPADE 2001". THE WORDING "ESCAPADE" IS IN PURPLE COLOR, OUTLINED IN WHITE, WITH BLACK SHADOWS; AND THE WORDING "2001" IS IN WHITE COLOR OUTLINED IN BLACK.

FOR ARRANGING AND CONDUCTING NIGHTCLUB ENTERTAINMENT EVENTS; MUSIC-HALLS; NIGHT CLUBS; PROVIDING DANCE HALLS (U.S. CLS. 100, 101 AND 107).

FIRST USE 10-5-2001; IN COMMERCE 10-5-2001.
DAWN HAN, EXAMINING ATTORNEY

SN 85-273,562. THE JEWISH THEOLOGICAL SEMINARY OF AMERICA, NEW YORK, NY. FILED 3-22-2011.

RAMAH

THE MARK CONSISTS OF STANDARD CHARACTERS WITHOUT CLAIM TO ANY PARTICULAR FONT, STYLE, SIZE, OR COLOR.

OWNER OF U.S. REG. NO. 3,025,695.

THE ENGLISH TRANSLATION OF THE WORD "RAMAH" IN THE MARK IS "LEVEL".

FOR NON-DOWNLOADABLE ON-LINE ELECTRONIC NEWSLETTERS IN THE FIELD OF JUDAICA AND JEWISH STUDIES (U.S. CLS. 100, 101 AND 107).

FIRST USE 4-0-2008; IN COMMERCE 4-0-2008.
HANNO RITTNER, EXAMINING ATTORNEY

CLASS 41—(Continued).

SN 85-273,569. GENIUS MEDIA GROUP LLC, BROOKLYN, NY. FILED 3-22-2011.

Rap Genius

THE MARK CONSISTS OF STANDARD CHARACTERS WITHOUT CLAIM TO ANY PARTICULAR FONT, STYLE, SIZE, OR COLOR.

NO CLAIM IS MADE TO THE EXCLUSIVE RIGHT TO USE "RAP", APART FROM THE MARK AS SHOWN.

FOR ONLINE WEBSITE FOR ENTERTAINMENT AND EDUCATIONAL PURPOSES PROVIDING USER-SUBMITTED INTERPRETATIONS OF SONG LYRICS, POETRY AND LITERATURE AND A BLOG ABOUT THE SAME (U.S. CLS. 100, 101 AND 107).

FIRST USE 1-2-2010; IN COMMERCE 1-2-2010.
HANNO RITTNER, EXAMINING ATTORNEY

SN 85-273,576. SHAUNA LANGFORD-PISCITELLO, DEL MAR, CA. FILED 3-22-2011.

SERENITY MINDFULNESS PROGRAM

THE MARK CONSISTS OF STANDARD CHARACTERS WITHOUT CLAIM TO ANY PARTICULAR FONT, STYLE, SIZE, OR COLOR.

NO CLAIM IS MADE TO THE EXCLUSIVE RIGHT TO USE "PROGRAM", APART FROM THE MARK AS SHOWN.

FOR TRAINING SERVICES, NAMELY, YOGA AND MEDITATION TRAINING FOR INDIVIDUALS AND GROUPS (U.S. CLS. 100, 101 AND 107).

KATHLEEN M. VANSTON, EXAMINING ATTORNEY

SN 85-273,577. HANK CAMPBELL ENTERPRISES, INC., ST. PETERSBURG, FL. FILED 3-22-2011.



NO CLAIM IS MADE TO THE EXCLUSIVE RIGHT TO USE "COACHING GROUP", APART FROM THE MARK AS SHOWN.

THE MARK CONSISTS OF THE WORD "PERFORM" STACKED OVER A LINE WHICH IS IN TURN STACKED OVER THE WORDS "COACHING GROUP" WHICH ARE PLACED BETWEEN TWO SHORT ELEVATED LINES. TO THE LEFT OF THIS ARE THREE CIRCLES SHARING A CENTER POINT.

FOR PERSONAL COACHING SERVICES IN THE FIELD OF TRIATHLON, NAMELY, SWIMMING, RUNNING AND CYCLING (U.S. CLS. 100, 101 AND 107).

FIRST USE 3-21-2011; IN COMMERCE 3-21-2011.
KATHLEEN M. VANSTON, EXAMINING ATTORNEY

CLASS 41—(Continued).

SN 85-273,618. FINANCIAL OPERATIONS NETWORKS LLC, ATLANTA, GA. FILED 3-22-2011.

AP ProTrain

THE MARK CONSISTS OF STANDARD CHARACTERS WITHOUT CLAIM TO ANY PARTICULAR FONT, STYLE, SIZE, OR COLOR.

NO CLAIM IS MADE TO THE EXCLUSIVE RIGHT TO USE "AP", APART FROM THE MARK AS SHOWN.

FOR EDUCATIONAL SERVICES, NAMELY, CONDUCTING AND DEVELOPING TRAINING COURSES IN THE FIELD OF ACCOUNTS PAYABLE (U.S. CLS. 100, 101 AND 107).

FIRST USE 11-18-2010; IN COMMERCE 11-18-2010.
AMY KERTGATE, EXAMINING ATTORNEY

SN 85-273,625. FINANCIAL OPERATIONS NETWORKS LLC, ATLANTA, GA. FILED 3-22-2011.



THE COLOR(S) YELLOW, ORANGE, BLACK, WHITE AND BLUE IS/ARE CLAIMED AS A FEATURE OF THE MARK.

THE MARK CONSISTS OF A CHARACTER DESIGN WITH A YELLOW INVOICE BODY, AN ORANGE PIECE OF PAPER BEHIND IT, ORANGE OUTSTRETCHED ARMS, ORANGE LEGS, WHITE AND BLUE EYES, BLACK EYEBROWS, AND BLACK MOUTH WITH A WHITE TONGUE. THE INVOICE BODY, ORANGE PAPER BEHIND IT, ARMS, LEGS AND EYES ARE ALL OUTLINED IN BLACK. THE WORD "INVOICE" APPEARS IN ORANGE BETWEEN THE CHARACTER'S EYEBROWS, THE WORDS "BILL" AND "SHIP" APPEAR IN ORANGE TO THE LEFT OF THE CHARACTER'S EYES, AND ORANGE HORIZONTAL LINES APPEAR TO THE RIGHT OF THE CHARACTER'S EYES AND BELOW ITS MOUTH. THE MARK APPEARS ON A TRANSPARENT BACKGROUND.

FOR EDUCATIONAL SERVICES, NAMELY, CONDUCTING AND DEVELOPING TRAINING COURSES IN THE FIELD OF ACCOUNTS PAYABLE (U.S. CLS. 100, 101 AND 107).

FIRST USE 5-0-2010; IN COMMERCE 5-0-2010.
AMY KERTGATE, EXAMINING ATTORNEY

CLASS 41—(Continued).

SN 85-273,668. DREAM SEASON, INC., LAFAYETTE, IN. FILED 3-22-2011.

DREAM SEASON

THE MARK CONSISTS OF STANDARD CHARACTERS WITHOUT CLAIM TO ANY PARTICULAR FONT, STYLE, SIZE, OR COLOR.

FOR PROVIDING SPORTS CAMPS FOR CHILDREN AND ADULTS WITH INTELLECTUAL AND DEVELOPMENTAL DISABILITIES (U.S. CLS. 100, 101 AND 107).

FIRST USE 3-16-2011; IN COMMERCE 3-16-2011.
SIMON TENG, EXAMINING ATTORNEY

SN 85-273,671. BALL, KIM D, DBA DELIBERATE MOVEMENT, LONG BEACH, CA. FILED 3-22-2011.

Deliberate Movement

THE MARK CONSISTS OF STANDARD CHARACTERS WITHOUT CLAIM TO ANY PARTICULAR FONT, STYLE, SIZE, OR COLOR.

NO CLAIM IS MADE TO THE EXCLUSIVE RIGHT TO USE "MOVEMENT", APART FROM THE MARK AS SHOWN.

FOR PHYSICAL FITNESS TRAINING OF INDIVIDUALS AND GROUPS (U.S. CLS. 100, 101 AND 107).

FIRST USE 4-14-2006; IN COMMERCE 4-14-2006.
SIMON TENG, EXAMINING ATTORNEY

SN 85-273,712. MARIN CYCLIST CLUB, SAN RAFAEL, CA. FILED 3-22-2011.

MARIN CENTURY

THE MARK CONSISTS OF STANDARD CHARACTERS WITHOUT CLAIM TO ANY PARTICULAR FONT, STYLE, SIZE, OR COLOR.

NO CLAIM IS MADE TO THE EXCLUSIVE RIGHT TO USE "CENTURY", APART FROM THE MARK AS SHOWN. SEC. 2(F).

FOR ENTERTAINMENT SERVICES, NAMELY, CONDUCTING ORGANIZED BICYCLE RIDES, INCLUDING ENDURANCE BICYCLE RIDES (U.S. CLS. 100, 101 AND 107).

FIRST USE 0-0-1962; IN COMMERCE 0-0-1962.
ELLEN B. AWRICH, EXAMINING ATTORNEY

CLASS 41—(Continued).

SN 85-273,758. MARY WESSNER PHOTOGRAPHY, CHARLESTON, SC. FILED 3-22-2011.



NO CLAIM IS MADE TO THE EXCLUSIVE RIGHT TO USE "PHOTOGRAPHY", APART FROM THE MARK AS SHOWN.

THE NAME "MARY WESSNER" IDENTIFIES A LIVING INDIVIDUAL WHOSE CONSENT IS OF RECORD.

THE MARK CONSISTS OF THE STYLIZED TEXT "MARY WESSNER PHOTOGRAPHY" WITH A HEART LOGO ON THE "M".

FOR PHOTOGRAPHY SERVICES (U.S. CLS. 100, 101 AND 107).

FIRST USE 12-4-2010; IN COMMERCE 12-4-2010.
JAY FLOWERS, EXAMINING ATTORNEY

SN 85-273,887. MUSIC MAKERS HOLDINGS LLC, BETHESDA, MD. FILED 3-22-2011.

ROCK CITY KIDS

THE MARK CONSISTS OF STANDARD CHARACTERS WITHOUT CLAIM TO ANY PARTICULAR FONT, STYLE, SIZE, OR COLOR.

NO CLAIM IS MADE TO THE EXCLUSIVE RIGHT TO USE "ROCK" OR "KIDS", APART FROM THE MARK AS SHOWN.

FOR EDUCATIONAL SERVICES, NAMELY, MUSIC, MOVEMENT AND MOTOR SKILLS CLASSES; EDUCATIONAL SERVICES, NAMELY, PROVIDING PROGRAMS FOR CHILDREN IN THE FIELD OF MUSIC, MOVEMENT AND MOTOR SKILLS (U.S. CLS. 100, 101 AND 107).

ALYSSA STEEL, EXAMINING ATTORNEY

CLASS 41—(Continued).

SN 85-273,890. SIRUS A. FERDOWS FOR ESCAPADE HOUSTON CORP, HOUSTON, TX. FILED 3-22-2011.



NO CLAIM IS MADE TO THE EXCLUSIVE RIGHT TO USE "2010", APART FROM THE MARK AS SHOWN.

THE COLOR(S) PURPLE, BLACK AND WHITE IS/ARE CLAIMED AS A FEATURE OF THE MARK.

THE MARK CONSISTS OF THE STYLIZED WORDING "ESCAPADE 2010". THE WORDING "ESCAPADE" IS IN PURPLE COLOR, OUTLINED IN WHITE, WITH BLACK SHADOWS; AND THE WORDING "2010" IS IN WHITE COLOR OUTLINED IN BLACK.

FOR ARRANGING AND CONDUCTING NIGHTCLUB ENTERTAINMENT EVENTS; MUSIC-HALLS; NIGHT CLUBS; PROVIDING DANCE HALLS (U.S. CLS. 100, 101 AND 107).

FIRST USE 12-25-2009; IN COMMERCE 12-25-2009.
DAWN HAN, EXAMINING ATTORNEY

CLASS 41—(Continued).

SN 85-274,114. MARQUEZE, RHANDY, SÃO PAULO, BRAZIL, FILED 3-23-2011.

ICI INTEGRATED COACHING
INSTITUTE

THE MARK CONSISTS OF STANDARD CHARACTERS WITHOUT CLAIM TO ANY PARTICULAR FONT, STYLE, SIZE, OR COLOR.

NO CLAIM IS MADE TO THE EXCLUSIVE RIGHT TO USE "INTEGRATED COACHING INSTITUTE", APART FROM THE MARK AS SHOWN.

FOR EDUCATIONAL SERVICES, NAMELY, CONDUCTING CLASSES, SEMINARS, CONFERENCES, WORKSHOPS IN THE FIELD OF PERSONAL AND EXECUTIVE COACHING, AND DISTRIBUTION OF TRAINING MATERIAL IN CONNECTION THEREWITH; EDUCATIONAL AND ENTERTAINMENT SERVICES, NAMELY, PROVIDING MOTIVATIONAL AND EDUCATIONAL SPEAKERS (U.S. CLS. 100, 101 AND 107).

LAKEISHA LEWIS, EXAMINING ATTORNEY

SN 85-274,438. SOCIETY OF AMERICAN GASTROINTESTINAL AND ENDOSCOPIC SURGEONS (SAGES), LOS ANGELES, CA. FILED 3-23-2011.

SN 85-273,907. POLLARD BANKNOTE LIMITED PARTNERSHIP, WINNIPEG, MB, CANADA, FILED 3-22-2011.

PlayOn



NO CLAIM IS MADE TO THE EXCLUSIVE RIGHT TO USE "FUNDAMENTALS FOR SURGICAL ENERGY", APART FROM THE MARK AS SHOWN.

THE MARK CONSISTS OF ONE MALE PLUG AND ONE FEMALE PLUG FUSED TOGETHER WITH THE WORDS "FUSE" ABOVE IT AND THE WORDS "FUNDAMENTALS FOR SURGICAL ENERGY" BELOW IT, BORDERED BY A DOUBLE BORDER.

FOR EDUCATION SERVICES, NAMELY, PROVIDING ON-LINE AND HANDS-ON SELF STUDY PROGRAMS IN THE FIELD OF SAFE SURGICAL TECHNIQUE (U.S. CLS. 100, 101 AND 107).

HOWARD SMIGA, EXAMINING ATTORNEY

THE MARK CONSISTS OF STANDARD CHARACTERS WITHOUT CLAIM TO ANY PARTICULAR FONT, STYLE, SIZE, OR COLOR.

FOR PROVIDING LOTTERY SERVICES FEATURING A PLAYERS REWARD PROGRAM FOR LOTTERY TICKET PURCHASERS (U.S. CLS. 100, 101 AND 107).

CHRISTINE MARTIN, EXAMINING ATTORNEY

CLASS 41—(Continued).

SN 85-274,699. FULLBRIDGE, INC., CAMBRIDGE, MA. FILED 3-23-2011.



NO CLAIM IS MADE TO THE EXCLUSIVE RIGHT TO USE "PROGRAM", APART FROM THE MARK AS SHOWN.

THE MARK CONSISTS OF THE LETTERS "FP" IN LARGE STYLIZED TYPE AGAINST A SOLID SQUARE BACKGROUND; TO THE RIGHT ARE THE WORDS "THE FULLBRIDGE PROGRAM" IN STYLIZED TYPE.

FOR EDUCATIONAL SERVICES, NAMELY, PROVIDING LIVE AND ONLINE COURSES OF INSTRUCTION AND TRAINING AT THE UNIVERSITY, POST-GRADUATE, AND PROFESSIONAL LEVEL IN THE FIELD OF BUSINESS AND SUBJECTS RELATING TO BUSINESS, NAMELY, CONTINUING BUSINESS EDUCATION, FINANCE, BUSINESS STRATEGY, BUSINESS INNOVATION, BUSINESS PLANNING, PROJECT MANAGEMENT, AND PROFESSIONAL DEVELOPMENT (U.S. CLS. 100, 101 AND 107).

FIRST USE 9-22-2010; IN COMMERCE 9-22-2010.

HEATHER THOMPSON, EXAMINING ATTORNEY

SN 85-274,704. FULLBRIDGE, INC., CAMBRIDGE, MA. FILED 3-23-2011.

THE FULLBRIDGE PROGRAM

THE MARK CONSISTS OF STANDARD CHARACTERS WITHOUT CLAIM TO ANY PARTICULAR FONT, STYLE, SIZE, OR COLOR.

NO CLAIM IS MADE TO THE EXCLUSIVE RIGHT TO USE "PROGRAM", APART FROM THE MARK AS SHOWN.

FOR EDUCATIONAL SERVICES, NAMELY, PROVIDING LIVE AND ONLINE COURSES OF INSTRUCTION AND TRAINING AT THE UNIVERSITY, POST-GRADUATE, AND PROFESSIONAL LEVEL IN THE FIELD OF BUSINESS AND SUBJECTS RELATING TO BUSINESS, NAMELY, CONTINUING BUSINESS EDUCATION, FINANCE, BUSINESS STRATEGY, BUSINESS INNOVATION, BUSINESS PLANNING, PROJECT MANAGEMENT, AND PROFESSIONAL DEVELOPMENT (U.S. CLS. 100, 101 AND 107).

FIRST USE 9-22-2010; IN COMMERCE 9-22-2010.

HEATHER THOMPSON, EXAMINING ATTORNEY

CLASS 41—(Continued).

SN 85-275,476. PALMSTAR MEDIA CAPITAL LLC, SHERMAN OAKS, CA. FILED 3-24-2011.

PALMSTAR ENTERTAINMENT

THE MARK CONSISTS OF STANDARD CHARACTERS WITHOUT CLAIM TO ANY PARTICULAR FONT, STYLE, SIZE, OR COLOR.

NO CLAIM IS MADE TO THE EXCLUSIVE RIGHT TO USE "ENTERTAINMENT", APART FROM THE MARK AS SHOWN.

FOR MEDIA PRODUCTION SERVICES, NAMELY FILM PRODUCTION (U.S. CLS. 100, 101 AND 107).

FIRST USE 4-30-2004; IN COMMERCE 4-30-2004.

JANICE L. MCMORROW, EXAMINING ATTORNEY

SN 85-275,514. FLEMING, KELSEY, ANAHEIM, CA. FILED 3-24-2011.

Semper Fi Ministries

THE MARK CONSISTS OF STANDARD CHARACTERS WITHOUT CLAIM TO ANY PARTICULAR FONT, STYLE, SIZE, OR COLOR.

NO CLAIM IS MADE TO THE EXCLUSIVE RIGHT TO USE "MINISTRIES", APART FROM THE MARK AS SHOWN.

FOR EDUCATIONAL AND ENTERTAINMENT SERVICES, NAMELY, PROVIDING MOTIVATIONAL SPEAKING SERVICES IN THE FIELD OF RELIGION AND BUSINESS PRACTICES BASED ON EXPERIENCES IN THE MILITARY (U.S. CLS. 100, 101 AND 107).

FIRST USE 10-15-2010; IN COMMERCE 10-15-2010.

KAELIE KUNG, EXAMINING ATTORNEY

SN 85-275,747. MARK A. MITCHELL, SAN CLEMENTE, CA. FILED 3-24-2011.

1 LESS THAN 2

THE MARK CONSISTS OF STANDARD CHARACTERS WITHOUT CLAIM TO ANY PARTICULAR FONT, STYLE, SIZE, OR COLOR.

FOR EDUCATIONAL SERVICES, NAMELY, PROVIDING SEMINARS IN THE FIELDS OF SALES AND MARKETING STRATEGIES AND PERSONAL MOTIVATION (U.S. CLS. 100, 101 AND 107).

DAVID YONTEF, EXAMINING ATTORNEY

CLASS 41—(Continued).

SN 85-275,785. HOLLADAY, DARRELL R., LOUISVILLE, KY. FILED 3-24-2011.

COMEDY CARAVAN

THE MARK CONSISTS OF STANDARD CHARACTERS WITHOUT CLAIM TO ANY PARTICULAR FONT, STYLE, SIZE, OR COLOR.

NO CLAIM IS MADE TO THE EXCLUSIVE RIGHT TO USE "COMEDY", APART FROM THE MARK AS SHOWN.

FOR COMEDY CLUB SERVICES; ENTERTAINMENT IN THE NATURE OF VISUAL AND AUDIO PERFORMANCES, AND MUSICAL, VARIETY, NEWS AND COMEDY SHOWS; ENTERTAINMENT SERVICES IN THE NATURE OF COMEDY SHOWS; PRESENTATION OF LIVE COMEDY SHOWS; ARRANGING AND CONDUCTING LIVE PERFORMANCES OF MUSIC AND COMEDY (U.S. CLS. 100, 101 AND 107).

FIRST USE 10-31-2009; IN COMMERCE 10-31-2009.

DAVID C. REIHNER, EXAMINING ATTORNEY

SN 85-276,377. OHIO MOBILE GAMING CORP., CHAGRIN FALLS, OH. FILED 3-24-2011.



NO CLAIM IS MADE TO THE EXCLUSIVE RIGHT TO USE "OHIO MOBILE GAMING.COM", APART FROM THE MARK AS SHOWN.

THE COLOR(S) YELLOW, RED, AND GREEN IS/ARE CLAIMED AS A FEATURE OF THE MARK.

THE MARK CONSISTS OF OVERLAPPING ROUGHLY RECTANGULAR YELLOW, RED, AND GREEN BLOCKS BEARING THE LETTERS "O", "M", AND "G" RESPECTIVELY AND FOLLOWED BY A GREEN EXCLAMATION POINT. THE WORDING "OHIO MOBILE GAMING.COM" IS SITUATED UNDER THE LETTERS "O", "M", AND "G" AND ROUGHLY CENTERED. THE WORD "OHIO" IS IN YELLOW, "MOBILE" IS IN RED AND "GAMING.COM" IS IN GREEN. THE ALIGNMENT OF ALL CHARACTER AND DESIGN ELEMENTS IS ASKEW. THE COLOR WHITE REPRESENTS A TRANSPARENT AREA AND IS NOT A PART OF THE MARK.

FOR ENTERTAINMENT SERVICES, NAMELY, PROVIDING RENTALS OF MOBILE GAMING AND ENTERTAINMENT TRAILERS CONTAINING VIDEO GAMES OR LASER ENTERTAINMENT ACTIVITIES; AND PROVIDING RENTALS OF INFLATABLE AMUSEMENT DEVICES IN THE NATURE OF AIR INFLATED CUSHIONS, NAMELY, BOUNCE HOUSES, INFLATABLE OBSTACLE COURSES, INFLATABLE SLIDES, INFLATABLE JOUSTING ARENAS, INFLATABLE HORIZONTAL WATER SLIDES, INFLATABLE BUNGEE CORD TETHERED RUNNING TRACKS, AND INFLATABLE CARNIVAL GAMES (U.S. CLS. 100, 101 AND 107).

FIRST USE 10-13-2010; IN COMMERCE 10-13-2010.

RUDY R. SINGLETON, EXAMINING ATTORNEY

CLASS 41—(Continued).

SN 85-276,715. MYKEEZZ PRODUCTION, INC., NORTH MIAMI, FL. FILED 3-25-2011.

Mykeezz Productions

THE MARK CONSISTS OF STANDARD CHARACTERS WITHOUT CLAIM TO ANY PARTICULAR FONT, STYLE, SIZE, OR COLOR.

NO CLAIM IS MADE TO THE EXCLUSIVE RIGHT TO USE "PRODUCTIONS", APART FROM THE MARK AS SHOWN.

FOR AUDIO RECORDING AND PRODUCTION (U.S. CLS. 100, 101 AND 107).

JENNIFER MARTIN, EXAMINING ATTORNEY

SN 85-276,772. AMES, WILLIAM, GIFFIN, JR., TA WILLIE AMES, BURBANK, CA. FILED 3-25-2011.

Willie Ames

THE MARK CONSISTS OF STANDARD CHARACTERS WITHOUT CLAIM TO ANY PARTICULAR FONT, STYLE, SIZE, OR COLOR.

OWNER OF U.S. REG. NO. 3,972,353.

THE NAME "WILLIE AMES" IDENTIFIES A LIVING INDIVIDUAL WHOSE CONSENT IS OF RECORD.

FOR ENTERTAINMENT SERVICES, NAMELY, LIVE, TELEVISED AND MOVIE APPEARANCES BY A PROFESSIONAL ENTERTAINER (U.S. CLS. 100, 101 AND 107).

FIRST USE 1-1-2003, THE MARK WAS FIRST USED ANYWHERE IN A DIFFERENT FORM OTHER THAN THAT SOUGHT TO BE REGISTERED AT LEAST AS EARLY AS 01/01/2003.; IN COMMERCE 8-5-2006, THE MARK WAS FIRST USED IN COMMERCE IN A DIFFERENT FORM OTHER THAN THAT SOUGHT TO BE REGISTERED AT LEAST AS EARLY AS 08/05/2006..

SAMUEL E. SHARPER JR., EXAMINING ATTORNEY

CLASS 41—(Continued).

SN 85-276,774. VIKING RIVER CRUISES (BERMUDA) LTD., HAMILTON HM 11, BERMUDA, FILED 3-25-2011.

VIKING LONGSHIPS

THE MARK CONSISTS OF STANDARD CHARACTERS WITHOUT CLAIM TO ANY PARTICULAR FONT, STYLE, SIZE, OR COLOR.

OWNER OF U.S. REG. NOS. 2,796,425, 3,980,867 AND OTHERS.

FOR ARRANGING, ORGANIZING AND HOSTING SOCIAL ENTERTAINMENT EVENTS; ENTERTAINMENT AND EDUCATION SERVICES IN THE NATURE OF LIVE DANCE AND MUSICAL PERFORMANCES; ENTERTAINMENT INFORMATION; ENTERTAINMENT SERVICES, NAMELY, ORGANIZING AND CONDUCTING PARTIES, WINE AND FOOD TASTINGS, CONTESTS, STAGE SHOWS, NIGHTCLUB SHOWS, VARIETY AND COMEDY SHOWS, AND THEATRICAL PRODUCTIONS AND MUSICALS; ENTERTAINMENT SERVICES, NAMELY, CASINO GAMING; EDUCATIONAL SERVICES, NAMELY, CONDUCTING COOKING CLASSES, AND LECTURES, AND SEMINARS IN THE FIELDS OF MUSIC, THEATRE, AND FILM; VIDEO ARCADE SERVICES; LIBRARIES; IN-CABIN INTERACTIVE TELEVISION PROGRAMMING; HEALTH CLUB SERVICES, NAMELY, PROVIDING INSTRUCTION, CLASSES, AND EQUIPMENT IN THE FIELD OF PHYSICAL EXERCISE; ORGANIZING AND HOSTING CULTURAL AND ARTS EVENTS; ORGANIZATION OF EXHIBITIONS FOR CULTURAL OR EDUCATIONAL PURPOSES (U.S. CLS. 100, 101 AND 107).

JOHN GARTNER, EXAMINING ATTORNEY

SN 85-276,822. JAMES S MILLER, TA HAVERIN MUSIC, LEBANON, TN. FILED 3-25-2011.

Haverin

THE MARK CONSISTS OF STANDARD CHARACTERS WITHOUT CLAIM TO ANY PARTICULAR FONT, STYLE, SIZE, OR COLOR.

FOR ENTERTAINMENT AND EDUCATION SERVICES IN THE NATURE OF LIVE DANCE AND MUSICAL PERFORMANCES (U.S. CLS. 100, 101 AND 107).

FIRST USE 1-14-2008; IN COMMERCE 1-14-2008.
SHARON MEIER, EXAMINING ATTORNEY

CLASS 41—(Continued).

SN 85-277,376. DISSINGER, DANIEL, WILLISTON PARK, NY. FILED 3-25-2011.

IN STEREO PRESS

THE MARK CONSISTS OF STANDARD CHARACTERS WITHOUT CLAIM TO ANY PARTICULAR FONT, STYLE, SIZE, OR COLOR.

NO CLAIM IS MADE TO THE EXCLUSIVE RIGHT TO USE "PRESS", APART FROM THE MARK AS SHOWN.

FOR PUBLICATION OF BOOKS; PUBLICATION OF ELECTRONIC BOOKS AND JOURNALS ON-LINE, MUSIC, AND VISUAL ART; ELECTRONIC PUBLISHING SERVICES, NAMELY, PUBLICATION OF TEXT AND GRAPHIC WORKS OF OTHERS ON CD, DVD, AND ONLINE FEATURING POETRY, PROSE, MUSIC, PHOTOGRAPHS, AND VIDEO (U.S. CLS. 100, 101 AND 107).

MORGAN WYNNE, EXAMINING ATTORNEY

SN 85-277,723. HALL, ERNIE, AKRON, OH. FILED 3-26-2011.

AMBICIOUS FOR HILL TOP PRODUCTIONS

THE MARK CONSISTS OF STANDARD CHARACTERS WITHOUT CLAIM TO ANY PARTICULAR FONT, STYLE, SIZE, OR COLOR.

NO CLAIM IS MADE TO THE EXCLUSIVE RIGHT TO USE "PRODUCTIONS", APART FROM THE MARK AS SHOWN.

FOR MULTIMEDIA ENTERTAINMENT SERVICES IN THE NATURE OF RECORDING, PRODUCTION AND POST-PRODUCTION SERVICES IN THE FIELD OF MUSIC; PROVIDING AN INTERNET WEBSITE PORTAL IN THE FIELD OF MUSIC; PROVISION OF INFORMATION RELATING TO LIVE PERFORMANCES, ROAD SHOWS, LIVE STAGE EVENTS, THEATRICAL PERFORMANCES, LIVE MUSIC CONCERTS AND AUDIENCE PARTICIPATION IN SUCH EVENTS (U.S. CLS. 100, 101 AND 107).

HANNO RITTNER, EXAMINING ATTORNEY

SN 85-277,765. HEART TANGO INC., MIAMI, FL. FILED 3-26-2011.

It's Time To Speed Date

THE MARK CONSISTS OF STANDARD CHARACTERS WITHOUT CLAIM TO ANY PARTICULAR FONT, STYLE, SIZE, OR COLOR.

FOR ENTERTAINMENT SERVICES, NAMELY, CONDUCTING PARTIES FOR THE PURPOSE OF DATING AND SOCIAL INTRODUCTION FOR ADULTS (U.S. CLS. 100, 101 AND 107).

FIRST USE 3-26-2011; IN COMMERCE 3-26-2011.
PAUL F. GAST, EXAMINING ATTORNEY

CLASS 41—(Continued).

SN 85-277,806. MULLISEN, RONALD, LOS OSOS, CA. FILED 3-26-2011.

Iron Mill Press

THE MARK CONSISTS OF STANDARD CHARACTERS WITHOUT CLAIM TO ANY PARTICULAR FONT, STYLE, SIZE, OR COLOR.

NO CLAIM IS MADE TO THE EXCLUSIVE RIGHT TO USE "PRESS", APART FROM THE MARK AS SHOWN.

FOR BOOK PUBLISHING (U.S. CLS. 100, 101 AND 107).
FIRST USE 11-29-2010; IN COMMERCE 11-29-2010.

GISELLE AGOSTO, EXAMINING ATTORNEY

SN 85-278,310. ALLEN, ROBIN LINDSLEY, VAN NUYS, CA. FILED 3-28-2011.

STRUT FIT

THE MARK CONSISTS OF STANDARD CHARACTERS WITHOUT CLAIM TO ANY PARTICULAR FONT, STYLE, SIZE, OR COLOR.

NO CLAIM IS MADE TO THE EXCLUSIVE RIGHT TO USE "FIT", APART FROM THE MARK AS SHOWN.

FOR PHYSICAL FITNESS CONDITIONING CLASSES; PHYSICAL FITNESS INSTRUCTION (U.S. CLS. 100, 101 AND 107).

FIRST USE 1-1-2011; IN COMMERCE 1-12-2011.

JULIE VEPPUMTHARA, EXAMINING ATTORNEY

SN 85-278,312. XTRAVAGANZA AB, VASTERAS, SWEDEN, FILED 3-28-2011.

XTRAVAGANZA

THE MARK CONSISTS OF STANDARD CHARACTERS WITHOUT CLAIM TO ANY PARTICULAR FONT, STYLE, SIZE, OR COLOR.

OWNER OF ERPN CMNTY TM OFC REG. NO. 004081477, DATED 1-11-2006, EXPIRES 10-20-2014.

FOR EDUCATION AND TRAINING SERVICES, NAMELY, CONDUCTING PROGRAMS, CLASSES, SEMINARS AND WORKSHOPS IN THE FIELDS OF WEIGHT LOSS AND HEALTH CARE; EDUCATION AND TRAINING SERVICES, NAMELY, TRAINING IN THE FIELDS OF WEIGHT LOSS AND HEALTH CARE (U.S. CLS. 100, 101 AND 107).

B. PARADEWELAI, EXAMINING ATTORNEY

CLASS 41—(Continued).

SN 85-278,528. BOTTON, TATIANA, SANTA MONICA, CA. FILED 3-28-2011.

WIP FLASH

THE MARK CONSISTS OF STANDARD CHARACTERS WITHOUT CLAIM TO ANY PARTICULAR FONT, STYLE, SIZE, OR COLOR.

FOR ENTERTAINMENT SERVICES IN THE NATURE OF PHOTOGRAPHY AND ART EXHIBITIONS (U.S. CLS. 100, 101 AND 107).

MATTHEW MCDOWELL, EXAMINING ATTORNEY

SN 85-280,005. CELTIC MEDIA CENTRE, LLC, BATON ROUGE, LA. FILED 3-29-2011.

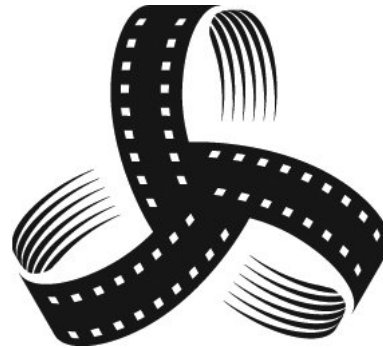

THE MARK CONSISTS OF TRADITIONAL CELTIC KNOT FORMING 3 INCOMPLETE CIRCLES THAT ARE TOUCHING OR INTERSECTING WITH A FILM STRIP REPRESENTED ON THE FRONT AND 6 LINES ON THE BACK SIDE.

FOR CINEMA STUDIOS; FILM STUDIOS; MOVIE STUDIOS; OPERATING OF FILM STUDIOS; PROVIDING AUDIO OR VIDEO STUDIOS; RECORDING STUDIO SERVICES; RECORDING STUDIOS; RENTAL OF FACILITIES AND EQUIPMENT FOR THE PRODUCTION OF RADIO AND TELEVISION PROGRAMS, MUSICAL AND THEATRICAL PRODUCTIONS, NAMELY, PERFORMANCE VENUES, STUDIOS, SETS, DRESSING ROOMS (U.S. CLS. 100, 101 AND 107).

FIRST USE 3-1-2011; IN COMMERCE 3-1-2011.

PRISCILLA MILTON, EXAMINING ATTORNEY

CLASS 41—(Continued).

SN 85-282,056. IMPACT SPORTS PERFORMANCE, LLC, BOCA RATON, FL. FILED 3-31-2011.



NO CLAIM IS MADE TO THE EXCLUSIVE RIGHT TO USE "SPORTS PERFORMANCE", APART FROM THE MARK AS SHOWN.

THE COLOR(S) ORANGE AND GREY IS/ARE CLAIMED AS A FEATURE OF THE MARK.

THE MARK CONSISTS OF A STYLIZED DEPICTION OF THE WORDING "SPORTS PERFORMANCE" IN GREY BENEATH THE STYLIZED WORD "IMPACT" WITH THE LETTERS SET IN AN ORANGE BACKGROUND, HIGHLIGHTED WITH GREY ELEMENTS THAT FORM THE LETTERS.

FOR SPORTS TRAINING SERVICES (U.S. CLS. 100, 101 AND 107).

FIRST USE 3-23-2011; IN COMMERCE 3-23-2011.
KATHERINE STOIDES, EXAMINING ATTORNEY

SN 85-282,256. MANCUSO, GARY, WESTON, FL. FILED 3-31-2011.

OUR DISAPPEARING WORLD

THE MARK CONSISTS OF STANDARD CHARACTERS WITHOUT CLAIM TO ANY PARTICULAR FONT, STYLE, SIZE, OR COLOR.

FOR EDUCATIONAL AND ENTERTAINMENT SERVICES, NAMELY, PROVIDING ONLINE PERSONAL JOURNALS FOCUSING ON ADVENTURE TRAVEL STORIES OF JOURNEYS TO AREAS NOT NORMALLY ASSOCIATED WITH MASS TOURISM, PARTICULARLY PLACES HARBORING IMPORTANT ASPECTS OF THE WORLD'S NATURAL AND CULTURAL HERITAGE IN DANGER OF DISAPPEARING OR BECOMING IRREVOCABLY ALTERED IN THE NEXT GENERATION DUE TO MODERNIZATION, GLOBALIZATION, CULTURAL HOMOGENIZATION AND ENVIRONMENTAL DESTRUCTION (U.S. CLS. 100, 101 AND 107).

FIRST USE 8-20-2010; IN COMMERCE 1-31-2011.
SOPHIA S. KIM, EXAMINING ATTORNEY

CLASS 41—(Continued).

SN 85-282,389. SANTOMARCO, TRACY, LOS ANGELES, CA. FILED 3-31-2011.



THE MARK CONSISTS OF A RECTANGULAR SHAPED FRAME AROUND THE WORDING "NO RING ON THIS THING" AND A PICTURE OF A HAND WITH THE RING FINGER EXTENDED, AND THE OTHER FINGERS ARE CURLED UNDER.

FOR ENTERTAINMENT SERVICES, NAMELY, PROVIDING A WEBSITE AT WHICH THE GENERAL PUBLIC CAN RECEIVE ADVICE FROM AN INDIVIDUAL CONCERNING RELATIONSHIPS, SUCH ADVICE BEING FOR ENTERTAINMENT PURPOSES ONLY (U.S. CLS. 100, 101 AND 107).

FIRST USE 2-0-2011; IN COMMERCE 2-0-2011.
RAMONA ORTIGA, EXAMINING ATTORNEY

SN 85-282,622. GOLD'S GYM LICENSING LLC, IRVING, TX. FILED 3-31-2011.



OWNER OF U.S. REG. NOS. 1,835,743, 2,002,430 AND OTHERS.

THE COLOR(S) YELLOW, RED AND WHITE IS/ARE CLAIMED AS A FEATURE OF THE MARK.

THE MARK CONSISTS OF CONCENTRIC CIRCLES CONSISTING OF A YELLOW BAND AROUND A WHITE BAND WHICH IS AROUND A RED CIRCLE IN WHICH STANDS A WEIGHTLIFTER IN WHITE.

FOR GYMNASIUM SERVICES; EXERCISE AND FITNESS SERVICES, NAMELY, PROVIDING FITNESS AND EXERCISE FACILITIES AND PHYSICAL FITNESS TRAINING OF INDIVIDUALS AND GROUPS (U.S. CLS. 100, 101 AND 107).

RAMONA ORTIGA, EXAMINING ATTORNEY

CLASS 41—(Continued).

SN 85-282,639. THE PAINTERS AND ALLIED TRADES LABOR-MANAGEMENT COOPERATION INITIATIVE, HANOVER, MD. FILED 3-31-2011.



NO CLAIM IS MADE TO THE EXCLUSIVE RIGHT TO USE "FINISHING INDUSTRIES FORUM THE PREMIER FINISHING TRADES ANNUAL EVENT", APART FROM THE MARK AS SHOWN.

THE COLOR(S) GOLD, BLUE AND WHITE IS/ARE CLAIMED AS A FEATURE OF THE MARK.

THE MARK CONSISTS OF A VERTICAL BLUE RECTANGLE SURROUNDED BY A THIN GOLD BORDER. WITHIN THE BLUE RECTANGLE ARE THE STYLIZED LETTERS "FIF" WHICH APPEAR IN GOLD SURROUNDED BY A THIN BLUE BORDER WHICH IS FOLLOWED BY A THIN WHITE BORDER. BELOW THESE LETTERS ARE THE WORDS "FINISHING INDUSTRIES FORUM" WHICH APPEAR IN GOLD. BELOW THESE WORDS ARE THE WORDS "THE PREMIER FINISHING TRADES ANNUAL EVENT" WHICH APPEAR IN WHITE.

FOR EDUCATION SERVICES, NAMELY, PROVIDING WORKSHOPS, SEMINARS, CLASSES AND TRAINING SESSIONS IN THE FIELDS OF PAINTING, DRYWALL, FLOOR AND WALL COVERING, GLAZING, SIGN PAINTING, LEAD ABATEMENT, GLASS INSTALLATION, METAL POLISHING, METAL REFINISHING, METAL SCRATCH REMOVAL AND HYDRO BLASTING (U.S. CLS. 100, 101 AND 107).

FIRST USE 6-30-2010; IN COMMERCE 6-30-2010.
JANET LEE, EXAMINING ATTORNEY

CLASS 41—(Continued).

SN 85-282,709. GOLD'S GYM LICENSING LLC, IRVING, TX. FILED 3-31-2011.



OWNER OF U.S. REG. NOS. 1,835,743, 2,002,430 AND OTHERS.

THE MARK CONSISTS OF CONCENTRIC CIRCLES CONSISTING OF 2 BANDS AROUND A CIRCLE IN WHICH STANDS A WEIGHTLIFTER.

FOR GYMNASIUM SERVICES; EXERCISE AND FITNESS SERVICES, NAMELY, PROVIDING FITNESS AND EXERCISE FACILITIES AND PHYSICAL FITNESS TRAINING OF INDIVIDUALS AND GROUPS (U.S. CLS. 100, 101 AND 107).

RAMONA ORTIGA, EXAMINING ATTORNEY

SN 85-282,911. FITNESS SENIOR STYLE LLC, WASHINGTON TOWNSHIP, NJ. FILED 3-31-2011.



NO CLAIM IS MADE TO THE EXCLUSIVE RIGHT TO USE "FITNESS" AND "SENIOR", APART FROM THE MARK AS SHOWN.

THE MARK CONSISTS OF THE WORDS "FITNESS SENIOR STYLE" VERTICALLY ALIGNED INSIDE A RECTANGLE WITH ROUNDED CORNERS, WITH THE LETTER "O" IN THE WORD "SENIOR" CONTAINING AN IMAGE IN THE SHAPE OF AN UPPER CASE "Y" WITH A CIRCLE IN THE TOP PORTION, INTENDED TO REPRESENT A HUMAN FIGURE WITH UP STRETCHED ARMS.

FOR PHYSICAL FITNESS TRAINING AND CONSULTATION SERVICES FOR SENIORS AND EDUCATIONAL SERVICES, NAMELY, PROVIDING COGNITIVE FITNESS PROGRAMS FOR SENIORS (U.S. CLS. 100, 101 AND 107).

FIRST USE 6-18-2010; IN COMMERCE 3-25-2011.
DEZMONA MIZELLE, EXAMINING ATTORNEY

CLASS 41—(Continued).

SN 85-285,211. CARMICAL BRIAN PATRICK, DBA R.U.KICK & ASSOCIATES, CLERMONT, GA. FILED 4-4-2011.

**R.U.KICK & ASSOCIATES
FIGHT CLUB**

THE MARK CONSISTS OF STANDARD CHARACTERS WITHOUT CLAIM TO ANY PARTICULAR FONT, STYLE, SIZE, OR COLOR.

NO CLAIM IS MADE TO THE EXCLUSIVE RIGHT TO USE "ASSOCIATES FIGHT CLUB", APART FROM THE MARK AS SHOWN.

FOR HEALTH CLUB SERVICES, NAMELY, PROVIDING INSTRUCTION AND EQUIPMENT IN THE FIELD OF PHYSICAL EXERCISE (U.S. CLS. 100, 101 AND 107).
MARCIE MILONE, EXAMINING ATTORNEY

SN 85-285,483. BOURGEIOS-BAHAR, VANEESAH, DECATUR, GA. FILED 4-4-2011.

Ms. Raw

THE MARK CONSISTS OF STANDARD CHARACTERS WITHOUT CLAIM TO ANY PARTICULAR FONT, STYLE, SIZE, OR COLOR.

THE NAME(S), PORTRAIT(S), AND/OR SIGNATURE(S) SHOWN IN THE MARK IDENTIFIES VANEESAH BOURGEIOS-BAHAR, WHOSE CONSENT(S) TO REGISTER IS MADE OF RECORD.

FOR ENTERTAINMENT IN THE NATURE OF LIVE PERFORMANCES BY A RECORDING ARTIST; ENTERTAINMENT SERVICES IN THE NATURE OF LIVE MUSICAL PERFORMANCES (U.S. CLS. 100, 101 AND 107).

FIRST USE 2-11-2000; IN COMMERCE 3-13-2003.
MARIA-VICTORIA SUAREZ, EXAMINING ATTORNEY

SN 85-286,073. WEEKLY READER CORPORATION, WHITE PLAINS, NY. FILED 4-5-2011.

LIT SCENE INVESTIGATION

THE MARK CONSISTS OF STANDARD CHARACTERS WITHOUT CLAIM TO ANY PARTICULAR FONT, STYLE, SIZE, OR COLOR.

NO CLAIM IS MADE TO THE EXCLUSIVE RIGHT TO USE "LIT", APART FROM THE MARK AS SHOWN.

FOR PROVIDING AN INTERACTIVE ONLINE EDUCATIONAL PUBLICATION IN THE NATURE OF A MAGAZINE IN THE FIELD OF READING (U.S. CLS. 100, 101 AND 107).

FIRST USE 9-3-2010; IN COMMERCE 9-3-2010.
GENE MACIOL, EXAMINING ATTORNEY

CLASS 41—(Continued).

SN 85-286,864. CINTAS HOLDINGS, LLC, MASON, OH. FILED 4-5-2011.

CINTAS

THE MARK CONSISTS OF STANDARD CHARACTERS WITHOUT CLAIM TO ANY PARTICULAR FONT, STYLE, SIZE, OR COLOR.

OWNER OF U.S. REG. NOS. 1,003,590, 3,166,081 AND OTHERS.

FOR FIRST AID AND WORKPLACE SAFETY TRAINING (U.S. CLS. 100, 101 AND 107).

FIRST USE 5-31-1999; IN COMMERCE 5-31-1999.
MATTHEW MCDOWELL, EXAMINING ATTORNEY

SN 85-287,712. KAHN COLLEGE CONSULTING, LLC, ARDMORE, PA. FILED 4-6-2011.



NO CLAIM IS MADE TO THE EXCLUSIVE RIGHT TO USE "COLLEGE CONSULTING, INC.", APART FROM THE MARK AS SHOWN.

THE MARK CONSISTS OF THE WORDING "KAHN" ABOVE THE IMAGE OF A KEY HAVING A SINGULAR WARD IN THE SHAPE OF A MORTARBOARD-WEARING HUMAN HEAD AND UPPER TORSO CUT OUT OF THE KEY'S BIT, THE KEY'S SHANK AND COLLAR BEING DIRECTLY ABOVE THE WORDING "COLLEGE CONSULTING, LLC".

FOR COLLEGE, GRADUATE AND PROFESSIONAL SCHOOL CONSULTING SERVICES, NAMELY, ASSISTING STUDENTS IN FINDING COLLEGES, UNIVERSITIES, GRADUATE AND PROFESSIONAL SCHOOLS AND COMPLETING THE APPLICATION PROCESS; ADMISSION CONSULTING SERVICES, NAMELY, CONSULTING IN THE FIELD OF COLLEGE, GRADUATE AND PROFESSIONAL SCHOOL ADMISSIONS, SPECIFICALLY, SCHOOL SELECTION, COMPLETING ADMISSIONS APPLICATIONS AND ESSAYS, AND PREPARATION FOR ADMISSION INTERVIEWS (U.S. CLS. 100, 101 AND 107).

FIRST USE 8-0-2008; IN COMMERCE 8-0-2008.
BRENDAN REGAN, EXAMINING ATTORNEY

CLASS 41—(Continued).

SN 85-288,311. TWENTIETH CENTURY FOX FILM CORPORATION, LOS ANGELES, CA. FILED 4-6-2011.

GEEK MEETS GIRL

THE MARK CONSISTS OF STANDARD CHARACTERS WITHOUT CLAIM TO ANY PARTICULAR FONT, STYLE, SIZE, OR COLOR.

FOR ENTERTAINMENT SERVICES IN THE NATURE OF A TELEVISION SERIES IN THE REALITY GENRE; PROVIDING ON-LINE INFORMATION IN THE FIELD OF REALITY TELEVISION SHOWS VIA A GLOBAL COMMUNICATIONS NETWORK; ENTERTAINMENT SERVICES IN THE NATURE OF NON-DOWNLOADABLE VIDEOS AND IMAGES FEATURING REALITY TELEVISION SHOWS TRANSMITTED VIA THE INTERNET AND WIRELESS COMMUNICATION NETWORKS; ON-LINE JOURNALS, NAMELY, BLOGS FEATURING PERSONAL OPINIONS IN THE FIELD OF GENERAL INTEREST AND REALITY TELEVISION SHOWS (U.S. CLS. 100, 101 AND 107).

MELISSA VALLILLO, EXAMINING ATTORNEY

SN 85-288,555. DAINTY HUNCHBACK, LLC, WYOMING, MI. FILED 4-7-2011.

FREE BEER & HOT WINGS

THE MARK CONSISTS OF STANDARD CHARACTERS WITHOUT CLAIM TO ANY PARTICULAR FONT, STYLE, SIZE, OR COLOR.

FOR RADIO ENTERTAINMENT SERVICES, NAMELY, RADIO PROGRAMS FEATURING PERFORMANCES BY FICTIONAL CHARACTERS TOGETHER WITH OTHER PERSONALITIES BOTH REAL AND FICTIONALLY (U.S. CLS. 100, 101 AND 107).

FIRST USE 3-1-1998; IN COMMERCE 3-1-1998.
BRENDAN REGAN, EXAMINING ATTORNEY

SN 85-288,560. ADLER, SHIRA T., KATONAH, NY. FILED 4-7-2011.

Have You Hugged Your Inner Diva Today?

THE MARK CONSISTS OF STANDARD CHARACTERS WITHOUT CLAIM TO ANY PARTICULAR FONT, STYLE, SIZE, OR COLOR.

FOR EDUCATION AND TRAINING; NAMELY, CONDUCTING WORKSHOPS AND TRAINING FOR WOMEN IN THE FIELD OF PERSONAL IMPROVEMENT (U.S. CLS. 100, 101 AND 107).

FIRST USE 3-3-2011; IN COMMERCE 3-3-2011.
STEVEN JACKSON, EXAMINING ATTORNEY

CLASS 41—(Continued).

SN 85-289,420. ECOTREK FITNESS LLC, SPRING LAKE, MI. FILED 4-7-2011.



OWNER OF U.S. REG. NO. 3,536,305.

NO CLAIM IS MADE TO THE EXCLUSIVE RIGHT TO USE "FITNESS", APART FROM THE MARK AS SHOWN.

THE COLOR(S) ORANGE, GREEN, WHITE AND BLUE IS/ARE CLAIMED AS A FEATURE OF THE MARK.

THE MARK CONSISTS OF AN ORANGE SUN TO THE LEFT, GREEN SUNBURST AROUND THE SUN, WHITE WORD "ECO" INSIDE THE SUN, "TREK" IN ORANGE OUTSIDE THE SUN TO THE RIGHT, "FITNESS" IN GREEN UNDERNEATH THE WORDS "ECOTREK", THE WORDS "NATURE ROCKS!" IN BLUE UNDERNEATH (CENTERED, WITH A BLUE KEYLINE UNDER AND OVER) AND THE WEB ADDRESS "WWW.ECOTREKFITNESS.COM" IN GREEN UNDERNEATH EVERYTHING, CENTERED.

FOR CONDUCTING FITNESS CLASSES (U.S. CLS. 100, 101 AND 107).

FIRST USE 5-14-2006; IN COMMERCE 5-14-2006.

ZACHARY BELLO, EXAMINING ATTORNEY

SN 85-289,830. SMITH, MICHELLE JEWELL, MINERAL POINT, WI. FILED 4-8-2011.

WE-WOMEN EXALTED BY GOD

THE MARK CONSISTS OF STANDARD CHARACTERS WITHOUT CLAIM TO ANY PARTICULAR FONT, STYLE, SIZE, OR COLOR.

FOR EDUCATIONAL SERVICES, NAMELY, CONDUCTING SEMINARS AND STUDY GROUPS IN THE FIELD OF RELIGION AND DISTRIBUTION OF BOOKS, COURSE MATERIALS AND EDUCATIONAL MATERIALS IN CONNECTION THEREWITH (U.S. CLS. 100, 101 AND 107).

GENE MACIOL, EXAMINING ATTORNEY

CLASS 41—(Continued).

SN 85-289,838. SMITH, MICHELLE JEWELL, MINERAL POINT, WI. FILED 4-8-2011.

ME-MEN EXALTED BY GOD

THE MARK CONSISTS OF STANDARD CHARACTERS WITHOUT CLAIM TO ANY PARTICULAR FONT, STYLE, SIZE, OR COLOR.

FOR EDUCATIONAL SERVICES, NAMELY, CONDUCTING SEMINARS AND STUDY GROUPS IN THE FIELD OF RELIGION AND DISTRIBUTION OF BOOKS, COURSE MATERIALS AND EDUCATIONAL MATERIALS IN CONNECTION THEREWITH (U.S. CLS. 100, 101 AND 107).

GENE MACIOL, EXAMINING ATTORNEY

SN 85-289,913. SPARKLE STORIES, LLC, CHARLOTTE, VT. FILED 4-8-2011.



THE MARK CONSISTS OF A SMILING CHILDLIKE FIGURE STANDING ON A PATCH OF GRASS, WEARING A HAT AND HOLDING A WAND WITH A STAR ON TOP OF THE WAND AND THREE STARS IN A CIRCULAR PATTERN TO THE LEFT OF THE FIGURE AND THE WORD "SPARKLESTORIES" TOWARD THE BOTTOM OF THE PICTURE.

FOR ENTERTAINMENT SERVICES, NAMELY, PROVIDING PODCASTS IN THE FIELD OF CHILDREN'S STORIES (U.S. CLS. 100, 101 AND 107).

FIRST USE 12-17-2010; IN COMMERCE 12-17-2010.
GENE MACIOL, EXAMINING ATTORNEY

SN 85-290,006. CLARK, DAVID P, LYONS, CO. FILED 4-8-2011.

AMERICAN THUNDER

THE MARK CONSISTS OF STANDARD CHARACTERS WITHOUT CLAIM TO ANY PARTICULAR FONT, STYLE, SIZE, OR COLOR.

FOR ENTERTAINMENT AND EDUCATIONAL SERVICES, NAMELY, LIVE MUSICAL CONCERTS AND PRODUCTION OF MOTION PICTURE FILMS RELATING THERETO, THAT PROMOTE MILITARY ISSUES (U.S. CLS. 100, 101 AND 107).

FIRST USE 11-16-2010; IN COMMERCE 3-8-2011.
ALLISON SCHRODY, EXAMINING ATTORNEY

CLASS 41—(Continued).

SN 85-290,033. RELEVANT HAIR, INC., NEW YORK, NY. FILED 4-8-2011.

RELEVANT

THE MARK CONSISTS OF STANDARD CHARACTERS WITHOUT CLAIM TO ANY PARTICULAR FONT, STYLE, SIZE, OR COLOR.

OWNER OF U.S. REG. NO. 3,725,331.

FOR EDUCATIONAL SERVICES, NAMELY, CONDUCTING CLASSES, SEMINARS, CONFERENCES, WORKSHOPS IN THE FIELD OF HAIRSTYLING, MAKE-UP, AND FASHION (U.S. CLS. 100, 101 AND 107).

FIRST USE 9-18-2006; IN COMMERCE 9-18-2006.

MICHELE SWAIN, EXAMINING ATTORNEY

SN 85-290,504. HERNANDEZ, OSCAR, LA VERNIA, TX. FILED 4-8-2011.



Chican@pedia

Mexican-American Library & Encyclopedia

NO CLAIM IS MADE TO THE EXCLUSIVE RIGHT TO USE "MEXICAN-AMERICAN LIBRARY & ENCYCLOPEDIA", APART FROM THE MARK AS SHOWN.

THE MARK CONSISTS OF A STYLIZED NATIVE AMERICAN IN A SITTING POSITION READING A BOOK IN FRONT OF A CIRCULAR BACKGROUND WITH STARS AND HIEROGLYPHS. BELOW THE DESIGN ELEMENTS IS THE WORDING "CHICAN@PEDIA MEXICAN-AMERICAN LIBRARY & ENCYCLOPEDIA".

FOR PROVIDING AN ON-LINE PUBLICATION IN THE NATURE OF AN INTERACTIVE ENCYCLOPEDIA IN THE FIELD OF MEXICAN-AMERICAN AND CHICANO CULTURE (U.S. CLS. 100, 101 AND 107).

JAMES STEIN, EXAMINING ATTORNEY

CLASS 41—(Continued).

SN 85-290,688. NIA TECHNIQUE INC., PORTLAND, OR.
FILED 4-8-2011.



OWNER OF U.S. REG. NOS. 2,341,516, 3,626,270 AND 3,626,271.

THE MARK CONSISTS OF A FANCIFUL REPRESENTATION OF A DANCER.

FOR PHYSICAL FITNESS STUDIO SERVICES, NAMELY, PROVIDING EXERCISE CLASSES, BODY SCULPTING CLASSES, AND GROUP FITNESS CLASSES; EDUCATIONAL SERVICES, NAMELY, CONDUCTING CLASSES, SEMINARS, AND WORKSHOPS IN THE FIELDS OF FITNESS, HEALTH, WELLNESS, EXERCISE, DANCE, YOGA, MARTIAL ARTS, AND T'AI CHI, AND DISTRIBUTION OF EDUCATIONAL AND TRAINING MATERIALS IN CONNECTION THEREWITH (U.S. CLS. 100, 101 AND 107).

FIRST USE 7-1-1992; IN COMMERCE 7-1-1992.

MICHELLE DUBOIS, EXAMINING ATTORNEY

SN 85-290,698. POWER TO BECOME INC, ATLANTA, GA.
FILED 4-8-2011.

Power To Become

THE MARK CONSISTS OF STANDARD CHARACTERS WITHOUT CLAIM TO ANY PARTICULAR FONT, STYLE, SIZE, OR COLOR.

FOR EDUCATION SERVICES, NAMELY, PROVIDING LIVE AND ON-LINE CLASSES, SEMINARS, WORKSHOPS IN THE FIELD OF MENTORING AND YOUTH OUTREACH (U.S. CLS. 100, 101 AND 107).

MICHELLE DUBOIS, EXAMINING ATTORNEY

CLASS 41—(Continued).

SN 85-290,828. NBA PROPERTIES, INC., NEW YORK, NY.
FILED 4-8-2011.

NBA

THE MARK CONSISTS OF STANDARD CHARACTERS WITHOUT CLAIM TO ANY PARTICULAR FONT, STYLE, SIZE, OR COLOR.

FOR ENTERTAINMENT AND EDUCATIONAL SERVICES IN THE NATURE OF ONGOING TELEVISION AND RADIO PROGRAMS IN THE FIELD OF BASKETBALL AND RENDERING LIVE BASKETBALL GAMES AND BASKETBALL EXHIBITIONS; THE PRODUCTION AND DISTRIBUTION OF RADIO AND TELEVISION SHOWS FEATURING BASKETBALL GAMES, BASKETBALL EVENTS AND PROGRAMS IN THE FIELD OF BASKETBALL; CONDUCTING AND ARRANGING BASKETBALL CLINICS AND CAMPS, COACHES CLINICS AND CAMPS, DANCE TEAM CLINICS AND CAMPS AND BASKETBALL GAMES; ENTERTAINMENT SERVICES IN THE NATURE OF PERSONAL APPEARANCES BY A COSTUMED MASCOT OR DANCE TEAM AT BASKETBALL GAMES AND EXHIBITIONS, CLINICS, CAMPS, PROMOTIONS, AND OTHER BASKETBALL-RELATED EVENTS, SPECIAL EVENTS AND PARTIES; FAN CLUB SERVICES; ENTERTAINMENT SERVICES, NAMELY PROVIDING A WEBSITE FEATURING MULTIMEDIA MATERIAL IN THE NATURE OF TELEVISION HIGHLIGHTS, INTERACTIVE TELEVISION HIGHLIGHTS, VIDEO RECORDINGS, VIDEO STREAM RECORDINGS, INTERACTIVE VIDEO HIGHLIGHT SELECTIONS, RADIO PROGRAMS, RADIO HIGHLIGHTS, AND AUDIO RECORDINGS IN THE FIELD OF BASKETBALL; PROVIDING NEWS AND INFORMATION IN THE NATURE OF STATISTICS AND TRIVIA IN THE FIELD OF BASKETBALL; ON-LINE NON-DOWNLOADABLE GAMES, NAMELY, COMPUTER GAMES, VIDEO GAMES, INTERACTIVE VIDEO GAMES, ACTION SKILL GAMES, ARCADE GAMES, ADULTS' AND CHILDREN'S PARTY GAMES, BOARD GAMES, PUZZLES, AND TRIVIA GAMES; ELECTRONIC PUBLISHING SERVICES, NAMELY, PUBLICATION OF MAGAZINES, GUIDES, NEWSLETTERS, COLORING BOOKS, AND GAME SCHEDULES OF OTHERS ON-LINE THROUGH THE INTERNET, ALL IN THE FIELD OF BASKETBALL; PROVIDING AN ONLINE COMPUTER DATABASE IN THE FIELD OF BASKETBALL (U.S. CLS. 100, 101 AND 107).

FIRST USE 11-1-1954; IN COMMERCE 11-1-1954.

BARBARA BROWN, EXAMINING ATTORNEY

CLASS 41—(Continued).

SN 85-290,967. MICHAEL ANTHONY PAOLICELLI, CHARLOTTE, NC. AND JANET PAOLICELLI, CHARLOTTE, NC. FILED 4-9-2011.

GODFACTOR

THE MARK CONSISTS OF STANDARD CHARACTERS WITHOUT CLAIM TO ANY PARTICULAR FONT, STYLE, SIZE, OR COLOR.

OWNER OF U.S. REG. NO. 2,797,575.

FOR ENTERTAINMENT SERVICES, NAMELY, THE PROVISION OF CONTINUING PROGRAMS, SEGMENTS AND SHOWS FEATURING NEWS, COMMENTARY, TEACHING ON SPIRITUAL TOPICS, THEOLOGY, LEADERSHIP, RELATIONSHIPS AND SUCCESS DELIVERED BY RADIO, PODCASTS, THE INTERNET, SATELLITE, TELEVISION AND LIVE PRESENTATIONS (U.S. CLS. 100, 101 AND 107).

FIRST USE 12-23-2003; IN COMMERCE 12-23-2003.

KELLY TRUSILO, EXAMINING ATTORNEY

SN 85-291,055. REASH, JORDAN, COLUMBUS, OH. FILED 4-9-2011.

Anabasis Photography

THE MARK CONSISTS OF STANDARD CHARACTERS WITHOUT CLAIM TO ANY PARTICULAR FONT, STYLE, SIZE, OR COLOR.

NO CLAIM IS MADE TO THE EXCLUSIVE RIGHT TO USE "PHOTOGRAPHY", APART FROM THE MARK AS SHOWN.

FOR PHOTOGRAPHY SERVICES (U.S. CLS. 100, 101 AND 107).

FIRST USE 12-1-2010; IN COMMERCE 12-1-2010.

KATHERINE CHANG, EXAMINING ATTORNEY

SN 85-291,103. DEFALA, SHARON OBERST, FORMERLY OBERST, SHARON, NORWALK, CT. FILED 4-9-2011.

Love Your Divorce

THE MARK CONSISTS OF STANDARD CHARACTERS WITHOUT CLAIM TO ANY PARTICULAR FONT, STYLE, SIZE, OR COLOR.

NO CLAIM IS MADE TO THE EXCLUSIVE RIGHT TO USE "DIVORCE", APART FROM THE MARK AS SHOWN.

FOR (BASED ON USE IN COMMERCE) ON-LINE JOURNALS, NAMELY, BLOGS FEATURING DIVORCE AND FAMILY LAW (BASED ON INTENT TO USE) WRITING OF ARTICLES FOR PERIODICALS OTHER THAN FOR ADVERTISING OR PUBLICITY (U.S. CLS. 100, 101 AND 107).

FIRST USE 3-27-2011; IN COMMERCE 3-27-2011.

MARGERY A. TIERNEY, EXAMINING ATTORNEY

CLASS 41—(Continued).

SN 85-291,147. KATE Siner FRANCIS, AKA KATE Siner, PROVIDENCE, RI. FILED 4-10-2011.

Life Fulfillment Formula

THE MARK CONSISTS OF STANDARD CHARACTERS WITHOUT CLAIM TO ANY PARTICULAR FONT, STYLE, SIZE, OR COLOR.

FOR LIFE COACHING SERVICES IN THE FIELD OF FULFILLMENT, HAPPINESS, PERSONAL GROWTH, RELATIONSHIP; PROVIDING GROUP COACHING AND LEARNING FORUMS IN THE FIELD OF LEADERSHIP DEVELOPMENT (U.S. CLS. 100, 101 AND 107).

FIRST USE 3-30-2011; IN COMMERCE 4-10-2011.

SAMUEL E. SHARPER JR., EXAMINING ATTORNEY

SN 85-291,153. VAQUERO STRATEGY, LLC, FORMERLY VAQUERO STRATEGY AND ENTERTAINMENT, LLC, SAN ANTONIO, TX. FILED 4-10-2011.



THE MARK CONSISTS OF THE LETTER "R", WITH THE MIRROR IMAGE OF THE LETTER "R" IMMEDIATELY TO ITS LEFT AND CONJOINED.

FOR ARRANGING AND CONDUCTING NIGHTCLUB ENTERTAINMENT EVENTS; DANCE EVENTS; ENTERTAINMENT, NAMELY, LIVE PERFORMANCES BY MUSICAL BANDS; NIGHT CLUBS; ORGANIZATION OF DANCING EVENTS; PROVIDING DANCE HALLS (U.S. CLS. 100, 101 AND 107).

GIANCARLO CASTRO, EXAMINING ATTORNEY

CLASS 41—(Continued).

SN 85-291,306. JAT INVESTMENTS, LLC, ABERDEEN, NC. FILED 4-11-2011.



THE MARK CONSISTS OF A SILHOUETTE OF A HEADLESS WOMAN KICKING HER LEG IN THE AIR SURROUNDED BY A CIRCLE.

FOR ADULT ENTERTAINMENT IN THE NATURE OF EXOTIC DANCE PERFORMANCES (U.S. CLS. 100, 101 AND 107).

FIRST USE 3-1-1990; IN COMMERCE 3-1-1990.
MICHAEL TANNER, EXAMINING ATTORNEY

CLASS 41—(Continued).

SN 85-291,525. UCLICK STUDIOS, LLC, DBA UCLICK STUDIOS, CHANHASSEN, MN. FILED 4-11-2011.

UClick Studios

THE MARK CONSISTS OF STANDARD CHARACTERS WITHOUT CLAIM TO ANY PARTICULAR FONT, STYLE, SIZE, OR COLOR.

NO CLAIM IS MADE TO THE EXCLUSIVE RIGHT TO USE "STUDIOS", APART FROM THE MARK AS SHOWN.

FOR PHOTOGRAPHY SERVICES; PROVIDING FACILITIES FOR PRODUCING VIDEO, CINEMA AND PHOTOGRAPHY PRODUCTIONS (U.S. CLS. 100, 101 AND 107).

FIRST USE 8-1-2010; IN COMMERCE 8-1-2010.
LOURDES AYALA, EXAMINING ATTORNEY

SN 85-291,434. SMARTSPORTS LLC, WESTFORD, MA. FILED 4-11-2011.

SMARTKAGE

THE MARK CONSISTS OF STANDARD CHARACTERS WITHOUT CLAIM TO ANY PARTICULAR FONT, STYLE, SIZE, OR COLOR.

FOR EVALUATION SERVICES OF ATHLETIC SKILLS AND POTENTIAL THROUGH MEASURING, COLLECTING, ANALYZING, AND REPORTING METRICS OF AN ATHLETE AND ATHLETIC PERFORMANCE (U.S. CLS. 100, 101 AND 107).

DANIEL CAPSHAW, EXAMINING ATTORNEY

SN 85-291,598. JOSEPHS, HOWARD, MILWAUKEE, WI. FILED 4-11-2011.



THE STIPPLING IS FOR SHADING PURPOSES ONLY. THE MARK CONSISTS OF A CIRCLE WITH A 9 POINT OUTLINED STAR WITH A DIAMOND INCRUSTED AND THE STYLIZED TEXT "NB" IN THE CENTER.

FOR PHOTOGRAPHY SERVICES; PRODUCTION OF SOUND RECORDINGS; PUBLICATION OF PRINTED MATTER; VIDEO PRODUCTION SERVICES (U.S. CLS. 100, 101 AND 107).

FIRST USE 4-11-2008; IN COMMERCE 4-11-2009.
ESTHER A. BORSUK, EXAMINING ATTORNEY

CLASS 41—(Continued).

SN 85-291,801. MEDIA CRAZY, INC., MIAMI, FL. FILED 4-11-2011.

Crazy SOBs

THE MARK CONSISTS OF STANDARD CHARACTERS WITHOUT CLAIM TO ANY PARTICULAR FONT, STYLE, SIZE, OR COLOR.

FOR ENTERTAINMENT SERVICES, NAMELY, PROVIDING A WEB SITE FEATURING PHOTOGRAPHIC AND PROSE PRESENTATIONS FEATURING MUSIC AND COMEDIC CONTENT; PROVIDING A WEBSITE FOR ENTERTAINMENT PURPOSES WHERE USERS CAN VIEW AND POST VIDEO SKITS FEATURING COMEDIC CONTENT (U.S. CLS. 100, 101 AND 107).

MARK SPARACINO, EXAMINING ATTORNEY

SN 85-292,183. HOWARD, JAMES FREDRICK, SAN DIEGO, CA. FILED 4-11-2011.



THE MARK CONSISTS OF AN OUTER CIRCLE ENCOMPASSING A SMALLER CIRCLE WITH FOUR SPOTS LOCATED ON THE TOP, BOTTOM, LEFT AND RIGHT OF THE CIRCLE, WHICH CONTAINS A SMALLER CIRCLE CONTAINING THE LETTER "Z". THE DESIGN CONTAINS IRREGULAR MARKS AND LINING AND IS PRESENTED INSIDE A SQUARE DESIGN.

FOR ARRANGING AND CONDUCTING SPECIAL EVENTS FOR SOCIAL ENTERTAINMENT PURPOSES; ORGANIZING CULTURAL AND ARTS EVENTS; ORGANIZING, ARRANGING, AND CONDUCTING OUTDOOR CULTURAL AND ARTS EVENTS, EDUCATIONAL CONFERENCES, AND EDUCATIONAL CONFERENCES IN THE FIELD OF SAFETY-AWARENESS (U.S. CLS. 100, 101 AND 107).

FIRST USE 3-19-2011; IN COMMERCE 3-19-2011.
CHRISTINE COOPER, EXAMINING ATTORNEY

CLASS 41—(Continued).

SN 85-292,225. LYNN HOFFMAN, LLC, DBA LYNN HOFFMAN ENTERTAINMENT, WOODBURY, CT. FILED 4-11-2011.

Private Sessions

THE MARK CONSISTS OF STANDARD CHARACTERS WITHOUT CLAIM TO ANY PARTICULAR FONT, STYLE, SIZE, OR COLOR.

FOR ENTERTAINMENT IN THE NATURE OF AN ONGOING MUSIC AND INTERVIEW TELEVISION AND RADIO SERIES FEATURING PERFORMING ARTISTS BROADCAST OVER TELEVISION, SATELLITE, THE INTERNET, AUDIO, AND VIDEO MEDIA (U.S. CLS. 100, 101 AND 107).

DAWN FELDMAN, EXAMINING ATTORNEY

SN 85-292,302. OLYATHLETE LLC, AUSTIN, TX. FILED 4-11-2011.

OlyAthlete

THE MARK CONSISTS OF STANDARD CHARACTERS WITHOUT CLAIM TO ANY PARTICULAR FONT, STYLE, SIZE, OR COLOR.

FOR PROVIDING A WEBSITE FEATURING INFORMATION PERTAINING TO THE SPORT OF COMPETITIVE WEIGHTLIFTING, AND STRENGTH AND CONDITIONING TRAINING; EDUCATIONAL SERVICES, NAMELY, PROVIDING SEMINARS PERTAINING TO THE SPORT OF COMPETITIVE WEIGHTLIFTING AND STRENGTH-AND-CONDITIONING TRAINING AND THE DISTRIBUTION OF EDUCATIONAL MATERIALS IN CONNECTION THEREWITH IN HARD COPY OR ELECTRONIC FORMAT ON THE SAME TOPICS; PROVIDING TRAINING PROGRAMS IN THE FIELD OF COMPETITIVE WEIGHTLIFTING; PROVIDING STRENGTH-AND-CONDITIONING TRAINING (U.S. CLS. 100, 101 AND 107).

FIRST USE 8-2-2010; IN COMMERCE 8-13-2010.
KAPIL BHANOT, EXAMINING ATTORNEY

CLASS 41—(Continued).

SN 85-292,350. GREGG, BRYAN R, BROOKLYN, NY. FILED 4-11-2011.



THE MARK CONSISTS OF THE LETTERS "S" AND "Z" SEPARATED BY A VERTICAL LINE. "GLASZI" SPELLED BELOW THE LETTERS. BOTH ARE ENCLOSED IN A RECTANGLE.

FOR FILM AND VIDEO PRODUCTION (U.S. CLS. 100, 101 AND 107).

FIRST USE 4-4-2011; IN COMMERCE 4-4-2011.

MATTHEW EINSTEIN, EXAMINING ATTORNEY

SN 85-292,435. JIL INTERNATIONAL, LLC, AUSTIN, TX. FILED 4-12-2011.

POKERTAINMENT

THE MARK CONSISTS OF STANDARD CHARACTERS WITHOUT CLAIM TO ANY PARTICULAR FONT, STYLE, SIZE, OR COLOR.

FOR ENTERTAINMENT SERVICES, NAMELY, ENTERTAINMENT-ONLY LIVE AND ONLINE PLAY OF CARD GAMES FOR VIRTUAL CURRENCY (U.S. CLS. 100, 101 AND 107).

FIRST USE 10-22-2010; IN COMMERCE 2-1-2011.

NELSON SNYDER, EXAMINING ATTORNEY

SN 85-292,685. CHICAGO SYMPHONY ORCHESTRA, CHICAGO, IL. FILED 4-12-2011.

ONCE UPON A SYMPHONY

THE MARK CONSISTS OF STANDARD CHARACTERS WITHOUT CLAIM TO ANY PARTICULAR FONT, STYLE, SIZE, OR COLOR.

FOR EDUCATIONAL AND ENTERTAINMENT SERVICES FOR CHILDREN, NAMELY PROVIDING EDUCATIONAL SERVICES IN THE NATURE OF STORYTELLING WITH LIVE MUSIC (U.S. CLS. 100, 101 AND 107).

DAVID I, EXAMINING ATTORNEY

CLASS 41—(Continued).

SN 85-292,693. CHICAGO SYMPHONY ORCHESTRA, CHICAGO, IL. FILED 4-12-2011.



THE MARK CONSISTS OF THE WORDS ONCE UPON A SYMPHONY WITH A MUSICAL NOTE AND THE OUTLINE SHAPE OF TWO SMALL HANDS.

FOR EDUCATIONAL AND ENTERTAINMENT SERVICES FOR CHILDREN, NAMELY PROVIDING EDUCATIONAL SERVICES IN THE NATURE OF STORYTELLING WITH LIVE MUSIC (U.S. CLS. 100, 101 AND 107).

DAVID I, EXAMINING ATTORNEY

SN 85-292,705. MATEER, PATRICK, MISSION VIEJO, CA. FILED 4-12-2011.

FOUR UNDER GOLF

THE MARK CONSISTS OF STANDARD CHARACTERS WITHOUT CLAIM TO ANY PARTICULAR FONT, STYLE, SIZE, OR COLOR.

NO CLAIM IS MADE TO THE EXCLUSIVE RIGHT TO USE "GOLF", APART FROM THE MARK AS SHOWN.

FOR PROVIDING NEWS AND INFORMATION ON THE SPORT OF GOLF (U.S. CLS. 100, 101 AND 107).

FIRST USE 10-1-2010; IN COMMERCE 10-1-2010.

TIMOTHY FINNEGAN, EXAMINING ATTORNEY

SN 85-292,721. LAMANTIA, DANIEL, NEW LENOX, IL. FILED 4-12-2011.

MUSTARD MEN

THE MARK CONSISTS OF STANDARD CHARACTERS WITHOUT CLAIM TO ANY PARTICULAR FONT, STYLE, SIZE, OR COLOR.

FOR ENTERTAINMENT IN THE NATURE OF LIVE MUSIC PERFORMANCES BY A MUSICAL GROUP (U.S. CLS. 100, 101 AND 107).

BARBARA A. GOLD, EXAMINING ATTORNEY

CLASS 41—(Continued).

SN 85-292,729. TRAFFIC JAM UNIVERSITY, LLC, SEATTLE, WA. FILED 4-12-2011.

THE DRIVE TO LEARN

THE MARK CONSISTS OF STANDARD CHARACTERS WITHOUT CLAIM TO ANY PARTICULAR FONT, STYLE, SIZE, OR COLOR.

FOR EDUCATIONAL SERVICES, NAMELY, PROVIDING ON-LINE CLASSES IN THE FIELD OF SELF IMPROVEMENT, PERSONAL GROWTH, COMMUNICATING, FINANCE AND LEADERSHIP (U.S. CLS. 100, 101 AND 107).

FIRST USE 10-1-2009; IN COMMERCE 10-1-2009.
GIANCARLO CASTRO, EXAMINING ATTORNEY



SN 85-292,976. RODAN MEDIA GROUP, INC., MINNEAPOLIS, MN. FILED 4-12-2011.

99 Problems

THE MARK CONSISTS OF STANDARD CHARACTERS WITHOUT CLAIM TO ANY PARTICULAR FONT, STYLE, SIZE, OR COLOR.

FOR ENTERTAINMENT SERVICES IN THE NATURE OF AN ON-GOING REALITY BASED TELEVISION PROGRAM, DELIVERED BY BROADCAST VIA TELEVISION, RADIO, INTERNET VIDEO, PODCAST, OR LIVE PERFORMANCE (U.S. CLS. 100, 101 AND 107).

FIRST USE 8-1-2010; IN COMMERCE 8-1-2010.
MICHAEL ENGEL, EXAMINING ATTORNEY

CLASS 41—(Continued).

SN 85-293,169. SWIM STRONG FOUNDATION, INC., EAST ELMHURST, NY. FILED 4-12-2011.

THE MARK CONSISTS OF A SINE-WAVE LIKE FORM WITH A CIRCULAR DOT NESTLED IN THE TROUGH OF THE WAVE.

FOR SWIMMING INSTRUCTION (U.S. CLS. 100, 101 AND 107).

FIRST USE 1-30-2007; IN COMMERCE 1-30-2007.
LIEF MARTIN, EXAMINING ATTORNEY

SN 85-292,982. LOVE, JASON, DAVIE, FL. FILED 4-12-2011.

MAKEITINTHEBIZ.COM

THE MARK CONSISTS OF STANDARD CHARACTERS WITHOUT CLAIM TO ANY PARTICULAR FONT, STYLE, SIZE, OR COLOR.

NO CLAIM IS MADE TO THE EXCLUSIVE RIGHT TO USE ".COM", APART FROM THE MARK AS SHOWN.

FOR ENTERTAINMENT IN THE NATURE OF PROVIDING AN INFORMATIONAL AND ENTERTAINMENT WEBSITE IN THE FIELDS OF CELEBRITY GOSSIP, ENTERTAINMENT, SPORTS AND FITNESS; ON-LINE JOURNALS, NAMELY, BLOGS FEATURING MUSIC AND ENTERTAINMENT INFORMATION; PROVIDING A WEBSITE FEATURING ENTERTAINMENT INFORMATION; PROVIDING A WEBSITE FEATURING INFORMATION IN THE FIELD OF MUSIC AND ENTERTAINMENT (U.S. CLS. 100, 101 AND 107).

DOMINIC J. FERRAIUOLO, EXAMINING ATTORNEY

SN 85-293,225. ARTISTS 4 ISRAEL, INC., NEW YORK, NY. FILED 4-12-2011.

SKIN

THE MARK CONSISTS OF STANDARD CHARACTERS WITHOUT CLAIM TO ANY PARTICULAR FONT, STYLE, SIZE, OR COLOR.

FOR EDUCATIONAL SERVICES, NAMELY PROVIDING ART EDUCATIONAL COURSES TO OTHERS (U.S. CLS. 100, 101 AND 107).

FIRST USE 5-31-2009; IN COMMERCE 5-31-2009.
KRISTINA MORRIS, EXAMINING ATTORNEY

CLASS 41—(Continued).

SN 85-293,444. SUMMER POWELL, PHILADELPHIA, PA. FILED 4-12-2011.

Lady Lights

THE MARK CONSISTS OF STANDARD CHARACTERS WITHOUT CLAIM TO ANY PARTICULAR FONT, STYLE, SIZE, OR COLOR.

THE NAME LADY LIGHTS IDENTIFIES A LIVING INDIVIDUAL WHOSE CONSENT IS OF RECORD.

FOR AUDIO RECORDING AND PRODUCTION; ENTERTAINMENT IN THE NATURE OF THEATER PRODUCTIONS; ENTERTAINMENT MEDIA PRODUCTION SERVICES FOR MOTION PICTURES, TELEVISION AND INTERNET; ENTERTAINMENT SERVICES BY A MUSICAL ARTIST AND PRODUCER, NAMELY, MUSICAL COMPOSITION FOR OTHERS AND PRODUCTION OF MUSICAL SOUND RECORDINGS; ENTERTAINMENT SERVICES IN THE NATURE OF DEVELOPMENT, CREATION, PRODUCTION AND POST-PRODUCTION SERVICES OF MULTIMEDIA ENTERTAINMENT CONTENT; ENTERTAINMENT SERVICES IN THE NATURE OF LIVE MUSICAL PERFORMANCES; ENTERTAINMENT SERVICES IN THE NATURE OF RECORDING, PRODUCTION AND POST-PRODUCTION SERVICES IN THE FIELD OF MUSIC; ENTERTAINMENT SERVICES, NAMELY, LIVE, TELEVISED AND MOVIE APPEARANCES BY A PROFESSIONAL ENTERTAINER; ENTERTAINMENT SERVICES, NAMELY, MULTIMEDIA PRODUCTION SERVICES; ENTERTAINMENT SERVICES, NAMELY, PERSONAL APPEARANCES BY A PROFESSIONAL ENTERTAINER; FILM AND VIDEO FILM PRODUCTION; FILM AND VIDEO PRODUCTION; FILM PRODUCTION; MOTION PICTURE FILM PRODUCTION; MOTION PICTURE SONG PRODUCTION; MUSIC PRODUCTION SERVICES; MUSIC VIDEO PRODUCTION; PRODUCTION AND DISTRIBUTION OF INDEPENDENT MOTION PICTURES; PRODUCTION AND DISTRIBUTION OF MOTION PICTURES; PRODUCTION AND DISTRIBUTION OF RADIO PROGRAMS; PRODUCTION AND DISTRIBUTION OF TELEVISION SHOWS AND MOVIES; PRODUCTION OF AUDIO RECORDING; PRODUCTION OF FILMS; PRODUCTION OF MUSICAL SOUND RECORDING; PRODUCTION OF MUSICAL VIDEOS; PRODUCTION OF RADIO AND TELEVISION PROGRAMS; PRODUCTION OF SOUND AND MUSIC VIDEO RECORDINGS; PRODUCTION OF SOUND RECORDINGS (U.S. CLS. 100, 101 AND 107).

TINA MAI, EXAMINING ATTORNEY

SN 85-293,454. OXIER, BRENT L., COVINA, CA. FILED 4-12-2011.

The Voodoo Kings

THE MARK CONSISTS OF STANDARD CHARACTERS WITHOUT CLAIM TO ANY PARTICULAR FONT, STYLE, SIZE, OR COLOR.

FOR ENTERTAINMENT SERVICES IN THE NATURE OF LIVE MUSICAL PERFORMANCES (U.S. CLS. 100, 101 AND 107).

FIRST USE 1-12-2011; IN COMMERCE 4-1-2011.

KARANENDRA S. CHHINA, EXAMINING ATTORNEY

CLASS 41—(Continued).

SN 85-293,475. ASSOCIATION OF BLACK CARDIOLOGISTS, AKA ABC, ATLANTA, GA. FILED 4-12-2011.

CHNN

THE MARK CONSISTS OF STANDARD CHARACTERS WITHOUT CLAIM TO ANY PARTICULAR FONT, STYLE, SIZE, OR COLOR.

FOR EDUCATIONAL AND ENTERTAINMENT SERVICES, NAMELY, ONGOING RADIO SHOWS IN THE FIELD OF PERSONAL HEALTH; CONTINUING PUBLIC SERVICE PROGRAMS IN THE FIELD OF PERSONAL HEALTH PRODUCED AND DISTRIBUTED OVER RADIO, TELEVISION, SATELLITE, AUDIO, VIDEO, AND INTERNET MEDIA (U.S. CLS. 100, 101 AND 107).

MARK SPARACINO, EXAMINING ATTORNEY

SN 85-293,495. NOBLE, KEVIN, FORT BELVOIR, VA. FILED 4-12-2011.



THE MARK CONSISTS OF AN ABSTRACT DESIGN. FOR PHOTOGRAPHY; PHOTOGRAPHY SERVICES; PORTRAIT PHOTOGRAPHY (U.S. CLS. 100, 101 AND 107).

VIVIAN MICZNIK FIRST, EXAMINING ATTORNEY

SN 85-293,758. FAKTR-PM, INC., ASHEVILLE, NC. FILED 4-13-2011.

FAKTR

THE MARK CONSISTS OF STANDARD CHARACTERS WITHOUT CLAIM TO ANY PARTICULAR FONT, STYLE, SIZE, OR COLOR.

FOR EDUCATIONAL SERVICES, NAMELY, CLASSES AND SEMINARS IN THE FIELD OF FUNCTIONAL AND KINETIC TREATMENT WITH REHABILITATION-PROVOCATION AND MOTION-IN THE DETECTION AND TREATMENT OF CHRONIC AND ACUTE MUSCULOSKELETAL AND FASCIAL CONDITIONS (U.S. CLS. 100, 101 AND 107).

FIRST USE 12-1-2003; IN COMMERCE 12-1-2003.

MARC LEIPZIG, EXAMINING ATTORNEY

CLASS 41—(Continued).

SN 85-293,803. KESSLER, BREANNE, EIELSON, AFB, AK. FILED 4-13-2011.

The Diva Within

THE MARK CONSISTS OF STANDARD CHARACTERS WITHOUT CLAIM TO ANY PARTICULAR FONT, STYLE, SIZE, OR COLOR.
FOR PHOTOGRAPHY SERVICES (U.S. CLS. 100, 101 AND 107).
FIRST USE 1-1-2009; IN COMMERCE 1-1-2009.
KEVIN CORWIN, EXAMINING ATTORNEY

CLASS 41—(Continued).

SN 85-294,041. BAKER, CHRISTIAN, NAPA, CA. FILED 4-13-2011.

Tastefully Offensive

THE MARK CONSISTS OF STANDARD CHARACTERS WITHOUT CLAIM TO ANY PARTICULAR FONT, STYLE, SIZE, OR COLOR.
FOR ENTERTAINMENT SERVICES, NAMELY, A WEBSITE FEATURING HUMOROUS PICTURES, VIDEOS AND COMICS (U.S. CLS. 100, 101 AND 107).
FIRST USE 6-0-2010; IN COMMERCE 6-0-2010.
JULIE WATSON, EXAMINING ATTORNEY

SN 85-293,924. CRAYONPIXEL, INC., GLENDALE, CA. FILED 4-13-2011.

CRAYONPIXEL

THE MARK CONSISTS OF STANDARD CHARACTERS WITHOUT CLAIM TO ANY PARTICULAR FONT, STYLE, SIZE, OR COLOR.
FOR ENTERTAINMENT SERVICES, NAMELY PROVIDING TEMPORARY USE OF NON-DOWNLOADABLE COMPUTER GAMES (U.S. CLS. 100, 101 AND 107).
THEODORE MCBRIDE, EXAMINING ATTORNEY

SN 85-294,162. STEVE SAILER, STUDIO CITY, CA. FILED 4-13-2011.

iSteve

THE MARK CONSISTS OF STANDARD CHARACTERS WITHOUT CLAIM TO ANY PARTICULAR FONT, STYLE, SIZE, OR COLOR.
FOR WRITING OF TEXTS (U.S. CLS. 100, 101 AND 107).
FIRST USE 10-8-1999; IN COMMERCE 10-8-1999.
RONALD MCMORROW, EXAMINING ATTORNEY

SN 85-293,931. APEX ORGANIZATION, INC., DBA BATTLE OF THE BRICKS, YPSILANTI, MI. FILED 4-13-2011.

Battle of the Bricks

THE MARK CONSISTS OF STANDARD CHARACTERS WITHOUT CLAIM TO ANY PARTICULAR FONT, STYLE, SIZE, OR COLOR.
FOR ORGANIZING AND CONDUCTING COMPETITIONS IN THE FIELD OF DESIGN AND ARCHITECTURE EDUCATION FOR YOUNG STUDENTS OF COLOR AGES 8-17 (U.S. CLS. 100, 101 AND 107).
FIRST USE 2-24-2011; IN COMMERCE 2-24-2011.
BRIAN CALLAGHAN, EXAMINING ATTORNEY

SN 85-294,346. LIEBERMAN, JANE PRICE, POUND RIDGE, NY. FILED 4-13-2011.

WE CAN SO RELATE

THE MARK CONSISTS OF STANDARD CHARACTERS WITHOUT CLAIM TO ANY PARTICULAR FONT, STYLE, SIZE, OR COLOR.
FOR PROVIDING A WEBSITE FEATURING BLOGS AND NON-DOWNLOADABLE PUBLICATIONS IN THE NATURE OF ARTICLES/COMMENTARY IN THE FIELD(S) OF RELATIONSHIPS AND COMMUNICATIONS (U.S. CLS. 100, 101 AND 107).
JOHN HWANG, EXAMINING ATTORNEY

CLASS 41—(Continued).

SN 85-294,415. MOSES, JAMAAL, COLUMBUS, OH. FILED 4-13-2011.

Buckeye Steel

THE MARK CONSISTS OF STANDARD CHARACTERS WITHOUT CLAIM TO ANY PARTICULAR FONT, STYLE, SIZE, OR COLOR.

FOR ENTERTAINMENT SERVICES IN THE NATURE OF PRESENTING LIVE MUSICAL PERFORMANCES; MULTIMEDIA ENTERTAINMENT SERVICES IN THE NATURE OF RECORDING, PRODUCTION AND POST-PRODUCTION SERVICES IN THE FIELDS OF MUSIC, VIDEO, AND FILMS (U.S. CLS. 100, 101 AND 107).

WILLIAM VERHOSEK, EXAMINING ATTORNEY

CLASS 41—(Continued).

SN 85-294,682. HARRIS, KIM, HARRISON TWP, MI. FILED 4-13-2011.

Wanted Team

THE MARK CONSISTS OF STANDARD CHARACTERS WITHOUT CLAIM TO ANY PARTICULAR FONT, STYLE, SIZE, OR COLOR.

FOR ENTERTAINMENT SERVICES IN THE NATURE OF LIVE MUSICAL PERFORMANCES (U.S. CLS. 100, 101 AND 107).

WON TEAK OH, EXAMINING ATTORNEY

SN 85-294,686. SKECHERS U.S.A., INC. II, MANHATTAN BEACH, CA. FILED 4-13-2011.

SN 85-294,628. SKECHERS U.S.A., INC. II, MANHATTAN BEACH, CA. FILED 4-13-2011.

BELLA BALLERINA

PUNKIE ROSE

THE MARK CONSISTS OF STANDARD CHARACTERS WITHOUT CLAIM TO ANY PARTICULAR FONT, STYLE, SIZE, OR COLOR.

FOR ENTERTAINMENT, NAMELY, A CONTINUING ANIMATED ENTERTAINMENT SHOW BROADCAST OVER TELEVISION (U.S. CLS. 100, 101 AND 107).

KATHRYN COWARD, EXAMINING ATTORNEY

THE MARK CONSISTS OF STANDARD CHARACTERS WITHOUT CLAIM TO ANY PARTICULAR FONT, STYLE, SIZE, OR COLOR.

FOR ENTERTAINMENT, NAMELY, A CONTINUING ANIMATED ENTERTAINMENT SHOW BROADCAST OVER TELEVISION (U.S. CLS. 100, 101 AND 107).

KATHRYN COWARD, EXAMINING ATTORNEY

SN 85-294,787. ANOTHER WAY OF THINKING, LLC, ROSEDALE, NY. FILED 4-14-2011.

SN 85-294,675. KERR, JEANNE, BLOOMINGTON, IN. AND LOEWE, JORDAN, BLOOMINGTON, IN. FILED 4-13-2011.

musicians are athletes

THE MARK CONSISTS OF STANDARD CHARACTERS WITHOUT CLAIM TO ANY PARTICULAR FONT, STYLE, SIZE, OR COLOR.

FOR PHYSICAL FITNESS CONSULTATION (U.S. CLS. 100, 101 AND 107).

FIRST USE 9-1-2010; IN COMMERCE 9-1-2010.

ELISSA GARBER KON, EXAMINING ATTORNEY

arrive late still early

THE MARK CONSISTS OF STANDARD CHARACTERS WITHOUT CLAIM TO ANY PARTICULAR FONT, STYLE, SIZE, OR COLOR.

FOR ARRANGING AND CONDUCTING NIGHTCLUB ENTERTAINMENT EVENTS; ENTERTAINMENT EVENT BOOKING AGENCIES; NIGHT CLUB RESERVATION SERVICES, NAMELY, ARRANGING FOR ADMISSION TO NIGHT CLUBS AND NIGHT CLUB EVENTS; ORGANISATION OF SPORTS EVENTS IN THE FIELD OF FOOTBALL; ORGANIZATION OF EVENTS FOR CULTURAL PURPOSES; PARTY PLANNING; SOCIAL CLUB SERVICES, NAMELY, ARRANGING, ORGANIZING, AND HOSTING SOCIAL EVENTS, GET-TOGETHERS, AND PARTIES FOR CLUB MEMBERS (U.S. CLS. 100, 101 AND 107).

FIRST USE 4-1-2011; IN COMMERCE 4-1-2011.

WENDY JUN, EXAMINING ATTORNEY

CLASS 41—(Continued).

SN 85-294,979. DOCUCOMP, LLC, CAPE CHARLES, VA. FILED 4-14-2011.

DOCUCOMP

THE MARK CONSISTS OF STANDARD CHARACTERS WITHOUT CLAIM TO ANY PARTICULAR FONT, STYLE, SIZE, OR COLOR.

FOR EDUCATIONAL SERVICES, NAMELY, CONDUCTING CLASSES, SEMINARS, WORKSHOPS, AND PRESENTATIONS IN THE FIELDS OF CLINICAL DOCUMENTATION AND CLINICAL CODING AND DISTRIBUTION OF TRAINING MATERIAL IN CONNECTION THEREWITH (U.S. CLS. 100, 101 AND 107).

FIRST USE 1-1-2001; IN COMMERCE 1-1-2001.
GEOFFREY FOSDICK, EXAMINING ATTORNEY

SN 85-294,985. THE ST. JOE COMPANY, WATERSOUND, FL. FILED 4-14-2011.

ARVIDA

THE MARK CONSISTS OF STANDARD CHARACTERS WITHOUT CLAIM TO ANY PARTICULAR FONT, STYLE, SIZE, OR COLOR.

OWNER OF U.S. REG. NO. 2,948,060.
FOR PROVIDING FACILITIES FOR RECREATION ACTIVITIES (U.S. CLS. 100, 101 AND 107).
PAUL F. GAST, EXAMINING ATTORNEY

SN 85-295,178. BIKERS ADULT RALLY, L.L.C., ROYSE CITY, TX. FILED 4-14-2011.

BAR NONE, THE BEST RALLY IN TEXAS

THE MARK CONSISTS OF STANDARD CHARACTERS WITHOUT CLAIM TO ANY PARTICULAR FONT, STYLE, SIZE, OR COLOR.

FOR ENTERTAINMENT SERVICES, NAMELY, ORGANIZING AND CONDUCTING MOTORCYCLE EXHIBITION AND RALLIES (U.S. CLS. 100, 101 AND 107).

KAPIL BHANOT, EXAMINING ATTORNEY

CLASS 41—(Continued).

SN 85-295,195. LEE W. GEIGER, MORAGA, CA. FILED 4-14-2011.

VIEWS FROM THE CHEAP SEATS

THE MARK CONSISTS OF STANDARD CHARACTERS WITHOUT CLAIM TO ANY PARTICULAR FONT, STYLE, SIZE, OR COLOR.

FOR PROVIDING AN ONLINE COLUMN IN THE FIELD OF BUSINESS, POLITICS, THE ECONOMY AND POPULAR CULTURE (U.S. CLS. 100, 101 AND 107).

FIRST USE 5-29-2010; IN COMMERCE 1-24-2011.
KAREN BRACEY, EXAMINING ATTORNEY

SN 85-295,203. BIKERS ADULT RALLY, L.L.C., ROYSE CITY, TX. FILED 4-14-2011.

EXPECT THE UNEXPECTED

THE MARK CONSISTS OF STANDARD CHARACTERS WITHOUT CLAIM TO ANY PARTICULAR FONT, STYLE, SIZE, OR COLOR.

FOR ENTERTAINMENT SERVICES, NAMELY, ORGANIZING AND CONDUCTING MOTORCYCLE EXHIBITION AND RALLIES (U.S. CLS. 100, 101 AND 107).

KAPIL BHANOT, EXAMINING ATTORNEY

CLASS 41—(Continued).

SN 85-295,211. INGENIOUS FITNESS, LLC, ASHBURN, VA. FILED 4-14-2011.

DIGITAL Accountability

THE MARK CONSISTS OF STANDARD CHARACTERS WITHOUT CLAIM TO ANY PARTICULAR FONT, STYLE, SIZE, OR COLOR.

FOR CONSULTING SERVICES IN THE FIELDS OF FITNESS AND EXERCISE; COUNSELING SERVICES IN THE FIELD OF PHYSICAL FITNESS; PERSONAL FITNESS TRAINING SERVICES AND CONSULTANCY; PHYSICAL FITNESS CONSULTATION; PHYSICAL FITNESS STUDIO SERVICES, NAMELY, PROVIDING EXERCISE CLASSES, BODY SCULPTING CLASSES, AND GROUP FITNESS CLASSES; PHYSICAL FITNESS STUDIO SERVICES, NAMELY, PROVIDING GROUP EXERCISE INSTRUCTION, EQUIPMENT, AND FACILITIES; PHYSICAL FITNESS TRAINING OF INDIVIDUALS AND GROUPS; PHYSICAL FITNESS TRAINING SERVICES; PROVIDING A WEB SITE FEATURING INFORMATION ON EXERCISE AND FITNESS; PROVIDING A WEBSITE FEATURING INFORMATION ON EXERCISE AND FITNESS; PROVIDING AN INTERACTIVE WEBSITE FEATURING INFORMATION AND LINKS RELATING TO FITNESS; PROVIDING AN ON-LINE COMPUTER DATABASE FEATURING INFORMATION REGARDING EXERCISE AND FITNESS; PROVIDING ASSISTANCE, PERSONAL TRAINING AND PHYSICAL FITNESS CONSULTATION TO CORPORATE CLIENTS TO HELP THEIR EMPLOYEES MAKE PHYSICAL FITNESS, STRENGTH, CONDITIONING, AND EXERCISE ALTERATIONS IN THEIR DAILY LIVING (U.S. CLS. 100, 101 AND 107).

ALLISON HOLTZ, EXAMINING ATTORNEY

SN 85-295,483. ACADEMIX, FAIRFIELD, CT. FILED 4-14-2011.



THE MARK CONSISTS OF THE STYLIZED TEXT "A MIX OF ALL THINGS ACADEMIC..." ON THE TOP. AT THE BOTTOM THERE IS A STAR WITH THE STYLIZED UNDERLINED TEXT "ACADEMIX". THE "X" IS FORMED BY A RULER AND A PENCIL ERASER THAT ARE CROSSING. THERE IS AN APPLE ON TOP OF THE LETTER "I".

FOR PROVIDING COURSES OF INSTRUCTION AT THE PRE-K TO ELEMENTARY LEVEL (U.S. CLS. 100, 101 AND 107).

FIRST USE 8-29-2010; IN COMMERCE 8-29-2010.
JOHN WILKE, EXAMINING ATTORNEY

CLASS 41—(Continued).

SN 85-295,623. TRANSLATIONARY GLOBAL LANGUAGES L.L.C., NORTHRIDGE, CA. FILED 4-14-2011.

translationary

THE MARK CONSISTS OF STANDARD CHARACTERS WITHOUT CLAIM TO ANY PARTICULAR FONT, STYLE, SIZE, OR COLOR.

FOR TRANSLATION SERVICES (U.S. CLS. 100, 101 AND 107).

FIRST USE 1-1-2000; IN COMMERCE 1-1-2000.
WENDY JUN, EXAMINING ATTORNEY

SN 85-295,644. TUTTLE, JENNIFER, VICTORVILLE, CA. FILED 4-14-2011.

Loveographer

THE MARK CONSISTS OF STANDARD CHARACTERS WITHOUT CLAIM TO ANY PARTICULAR FONT, STYLE, SIZE, OR COLOR.

FOR PHOTOGRAPHY SERVICES (U.S. CLS. 100, 101 AND 107).

FIRST USE 3-28-2011; IN COMMERCE 3-28-2011.
ROBIN MITTLER, EXAMINING ATTORNEY

SN 85-295,669. AL MENCONI MINISTRIES, SAN MARCOS, CA. FILED 4-14-2011.

THE CHRISTIAN MUSIC DIET

THE MARK CONSISTS OF STANDARD CHARACTERS WITHOUT CLAIM TO ANY PARTICULAR FONT, STYLE, SIZE, OR COLOR.

NO CLAIM IS MADE TO THE EXCLUSIVE RIGHT TO USE "CHRISTIAN MUSIC", APART FROM THE MARK AS SHOWN.

FOR PROVIDING SEMINARS ON CHRISTIAN MUSIC AND DISTRIBUTION OF COURSE MATERIALS IN CONNECTION THEREWITH (U.S. CLS. 100, 101 AND 107).

FIRST USE 9-30-1990; IN COMMERCE 9-30-1990.
JOHN HWANG, EXAMINING ATTORNEY

CLASS 41—(Continued).

SN 85-295,683. PASSIONATESPOUSE, INCORPORATED, SUWANEE, GA. FILED 4-14-2011.

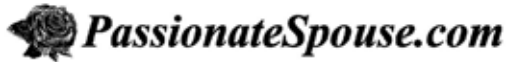

THE STIPLING IS FOR SHADING PURPOSES ONLY. THE MARK CONSISTS OF AN IMAGE OF A ROSE WITH LEAVES SURROUNDING IT. THE "ROSE" IMAGE IS TO THE LEFT OF THE WORK PHRASE "PASSIONATESPOUSE.COM". THE "ROSE" IMAGE IS FOLLOWED TO THE RIGHT BY "PASSIONATESPOUSE.COM", USING FONT TYPE "TIMES NEW ROMAN ITALIC", AND CAN BE FOUND IN ANY FONT SIZE.

FOR EDUCATIONAL SERVICES, NAMELY, CONDUCTING SEMINARS AND WORKSHOPS IN THE FIELD OF HEALTHY MARRIAGE RELATIONSHIPS AND DISTRIBUTION OF PRINTED MATERIALS IN CONNECTION THEREWITH IN HARD COPY OR ELECTRONIC FORMAT ON THE SAME TOPICS (U.S. CLS. 100, 101 AND 107).

LOURDES AYALA, EXAMINING ATTORNEY

SN 85-295,727. CARISA MELLADO, LOS ANGELES, CA. FILED 4-14-2011.

Magic Monster

THE MARK CONSISTS OF STANDARD CHARACTERS WITHOUT CLAIM TO ANY PARTICULAR FONT, STYLE, SIZE, OR COLOR.

FOR ENTERTAINMENT SERVICES, NAMELY, PROVIDING RADIO PROGRAMS IN THE FIELD OF ALTERNATIVE MUSIC VIA A GLOBAL COMPUTER NETWORK (U.S. CLS. 100, 101 AND 107).

FIRST USE 3-15-2010; IN COMMERCE 3-1-2011.

JOHN HWANG, EXAMINING ATTORNEY

SN 85-295,838. BARB, INC., DBA STAGEDHOMES.COM, BRENTWOOD, CA. FILED 4-14-2011.

STAGE

THE MARK CONSISTS OF STANDARD CHARACTERS WITHOUT CLAIM TO ANY PARTICULAR FONT, STYLE, SIZE, OR COLOR.

OWNER OF U.S. REG. NO. 1,652,964. SEC. 2(F).

FOR EDUCATIONAL SERVICES, NAMELY, PROVIDING CONFERENCES, WORKSHOPS, SEMINARS AND TRAINING COURSES IN THE FIELDS OF PREPARING HOMES FOR SALE (U.S. CLS. 100, 101 AND 107).

FIRST USE 7-5-1990; IN COMMERCE 7-5-1990.

KATHERINE CONNOLLY, EXAMINING ATTORNEY

CLASS 41—(Continued).

SN 85-296,284. HOME BOX OFFICE, INC., NEW YORK, NY. FILED 4-15-2011.



OWNER OF U.S. REG. NOS. 1,349,993, 3,904,923 AND OTHERS.

THE MARK CONSISTS OF "CINEMAX" IN SLANTED BLOCK LETTERS ON A QUADRILATERAL BACKGROUND.

FOR ENTERTAINMENT SERVICES, IN THE NATURE OF PROVIDING NON-DOWNLOADABLE ENTERTAINMENT PROGRAMS AND CONTENT, NAMELY, FILMS, TELEVISION PROGRAMS AND RELATED CLIPS, GRAPHICS AND INFORMATION IN THE FIELDS OF DRAMA, COMEDY, ACTION, ADVENTURE, DOCUMENTARY, SPORTS, MUSIC, VARIETY, ENTERTAINMENT NEWS, DOCUMENTARY AND ANIMATION RENDERED THROUGH THE MEDIA OF TELEVISION, CABLE AND SATELLITE SYSTEMS, THE INTERNET, ELECTRONIC COMMUNICATIONS NETWORKS AND WIRELESS COMMUNICATION NETWORKS; PRODUCTION AND DISTRIBUTION OF TELEVISION PROGRAMS AND MOTION PICTURES RENDERED THROUGH THE MEDIA OF TELEVISION, CABLE AND SATELLITE SYSTEMS, AND THE INTERNET; TELEVISION PROGRAMMING SERVICES; INTERACTIVE ONLINE ENTERTAINMENT IN THE NATURE OF A WEBSITE CONTAINING NON-DOWNLOADABLE PHOTOGRAPHIC, VIDEO AND PROSE PRESENTATIONS, RELATED VIDEO CLIPS AND OTHER MULTIMEDIA MATERIALS FEATURING CONTENT FROM OR RELATING TO TELEVISION PROGRAMS AND TELEVISION FILMS IN THE FIELDS OF DRAMA, COMEDY, ACTION, ADVENTURE, DOCUMENTARY, SPORTS, MUSIC, VARIETY, ENTERTAINMENT NEWS, DOCUMENTARY AND ANIMATION (U.S. CLS. 100, 101 AND 107).

SUSAN RICHARDS, EXAMINING ATTORNEY

SN 85-296,733. ROBERTS, BRANDON, WASHINGTON, DC. FILED 4-15-2011.

ANYCARD

THE MARK CONSISTS OF STANDARD CHARACTERS WITHOUT CLAIM TO ANY PARTICULAR FONT, STYLE, SIZE, OR COLOR.

FOR GAMING SERVICES IN THE NATURE OF CASINO GAMING (U.S. CLS. 100, 101 AND 107).

JOHN GARTNER, EXAMINING ATTORNEY

CLASS 41—(Continued).

SN 85-302,546. AGRO-CULTURE LIQUID FERTILIZERS, ST. JOHNS, MI. FILED 4-22-2011.

Nutrients Not Numbers

THE MARK CONSISTS OF STANDARD CHARACTERS WITHOUT CLAIM TO ANY PARTICULAR FONT, STYLE, SIZE, OR COLOR.

NO CLAIM IS MADE TO THE EXCLUSIVE RIGHT TO USE "NUTRIENTS", APART FROM THE MARK AS SHOWN.

FOR EDUCATION SERVICES, NAMELY, PROVIDING LIVE AND ON-LINE WORKSHOPS, SEMINARS, BLOGS IN THE FIELD OF FERTILIZERS, AND PLANT NUTRITION PREPARATIONS (U.S. CLS. 100, 101 AND 107).

DAVID COLLIER, EXAMINING ATTORNEY

SN 85-307,142. ULTERIOR MOTIF, LTD, DBA CARSON GROUP INTERNATIONAL, GLASSBORO, NJ. FILED 4-28-2011.

Go Diva

THE MARK CONSISTS OF STANDARD CHARACTERS WITHOUT CLAIM TO ANY PARTICULAR FONT, STYLE, SIZE, OR COLOR.

FOR ATHLETIC AND SPORTS EVENT SERVICES, NAMELY, ARRANGING, ORGANIZING, OPERATING AND CONDUCTING MARATHON RACES (U.S. CLS. 100, 101 AND 107).

FIRST USE 10-1-2009; IN COMMERCE 10-1-2009.
ANNE E. GUSTASON, EXAMINING ATTORNEY

SN 85-307,180. ULTERIOR MOTIF, LTD, DBA CARSON GROUP INTERNATIONAL, GLASSBORO, NJ. FILED 4-28-2011.

CGI Racing

THE MARK CONSISTS OF STANDARD CHARACTERS WITHOUT CLAIM TO ANY PARTICULAR FONT, STYLE, SIZE, OR COLOR.

NO CLAIM IS MADE TO THE EXCLUSIVE RIGHT TO USE "RACING", APART FROM THE MARK AS SHOWN.

FOR ATHLETIC AND SPORTS EVENT SERVICES, NAMELY, ARRANGING, ORGANIZING, OPERATING AND CONDUCTING MARATHON RACES (U.S. CLS. 100, 101 AND 107).

FIRST USE 9-1-2005; IN COMMERCE 11-1-2005.
ANNE E. GUSTASON, EXAMINING ATTORNEY

CLASS 41—(Continued).

SN 85-308,030. FANPLAY, INC., SLATON, TX. FILED 4-29-2011.

FANPLAY NATION

THE MARK CONSISTS OF STANDARD CHARACTERS WITHOUT CLAIM TO ANY PARTICULAR FONT, STYLE, SIZE, OR COLOR.

FOR ENTERTAINMENT SERVICES IN THE NATURE OF FANTASY SPORTS TEAM LEAGUES (U.S. CLS. 100, 101 AND 107).

LESLIE RICHARDS, EXAMINING ATTORNEY

SN 85-308,686. CRAYOLA PROPERTIES, INC., EASTON, PA. FILED 4-29-2011.

STORY STUDIO

THE MARK CONSISTS OF STANDARD CHARACTERS WITHOUT CLAIM TO ANY PARTICULAR FONT, STYLE, SIZE, OR COLOR.

NO CLAIM IS MADE TO THE EXCLUSIVE RIGHT TO USE "STORY", APART FROM THE MARK AS SHOWN.

FOR ENTERTAINMENT SERVICES, NAMELY, AN ON-LINE ACTIVITY FOR CREATING CARTOON CHARACTERS AND STORIES (U.S. CLS. 100, 101 AND 107).

FIRST USE 8-31-2010; IN COMMERCE 8-31-2010.
TOBY BULLOFF, EXAMINING ATTORNEY

SN 85-308,758. UNIVISION COMMUNICATIONS INC., LOS ANGELES, CA. FILED 4-29-2011.

EL TALISMAN

THE MARK CONSISTS OF STANDARD CHARACTERS WITHOUT CLAIM TO ANY PARTICULAR FONT, STYLE, SIZE, OR COLOR.

THE ENGLISH TRANSLATION OF "EL TALISMAN" IN THE MARK IS "THE TALISMAN".

FOR ENTERTAINMENT SERVICES, NAMELY, AN ONGOING CONTINUING DRAMA TELEVISION PROGRAM (U.S. CLS. 100, 101 AND 107).

ZACHARY BELLO, EXAMINING ATTORNEY

CLASS 41—(Continued).

SN 85-309,495. UCLICK STUDIOS, LLC, DBA UCLICK STUDIOS, CHANHASSEN, MN. FILED 5-2-2011.

UCLICK

THE MARK CONSISTS OF STANDARD CHARACTERS WITHOUT CLAIM TO ANY PARTICULAR FONT, STYLE, SIZE, OR COLOR.

FOR PHOTOGRAPHY SERVICES; PROVIDING FACILITIES FOR PRODUCING VIDEO, CINEMA AND PHOTOGRAPHY PRODUCTIONS (U.S. CLS. 100, 101 AND 107).

FIRST USE 8-1-2010; IN COMMERCE 8-1-2010.
LOURDES AYALA, EXAMINING ATTORNEY

CLASS 41—(Continued).

SN 85-313,937. TUPLER, JULIE, NEW YORK, NY. FILED 5-6-2011.

EVERYBELLY

THE MARK CONSISTS OF STANDARD CHARACTERS WITHOUT CLAIM TO ANY PARTICULAR FONT, STYLE, SIZE, OR COLOR.

FOR EDUCATION AND ENTERTAINMENT SERVICES, NAMELY, CONSULTING SERVICES IN THE FIELDS OF FITNESS AND EXERCISE; COUNSELING SERVICES IN THE FIELD OF PERSONAL FITNESS; PERSONAL FITNESS TRAINING SERVICES AND CONSULTANCY; PHYSICAL FITNESS CONDITIONING CLASSES (U.S. CLS. 100, 101 AND 107).

FIRST USE 4-1-2011; IN COMMERCE 4-25-2011.
HEATHER SAPP, EXAMINING ATTORNEY

SN 85-311,402. WHOLE FOODS MARKET IP, L.P., AUSTIN, TX. FILED 5-3-2011.

WHOLE STORY

THE MARK CONSISTS OF STANDARD CHARACTERS WITHOUT CLAIM TO ANY PARTICULAR FONT, STYLE, SIZE, OR COLOR.

FOR ON-LINE JOURNALS, NAMELY, BLOGS FEATURING FOOD AND FOOD RELATED CONTENT, COOKING, RECIPES, MEAL PLANNING, FOOD PRODUCTION, HEALTH, NUTRITION, MUSIC, PHILANTHROPY, SOCIAL WELFARE AND ACTIVISM, CONSERVATION, ECOLOGY, FLORA, WILDLIFE, AQUACULTURE, AND RELATED COMMENTARY; ENTERTAINMENT SERVICES, NAMELY, PROVIDING AUDIO PODCASTS FEATURING FOOD AND FOOD RELATED CONTENT, COOKING, RECIPES, MEAL PLANNING, FOOD PRODUCTION, HEALTH, AND NUTRITION; ENTERTAINMENT SERVICES, NAMELY, PROVIDING VIDEO PODCASTS FEATURING FOOD AND FOOD RELATED CONTENT, COOKING, RECIPES, MEAL PLANNING, FOOD PRODUCTION, HEALTH, AND NUTRITION; ENTERTAINMENT SERVICES, NAMELY, CONDUCTING CONTESTS (U.S. CLS. 100, 101 AND 107).

FIRST USE 6-2-2008; IN COMMERCE 6-2-2008.
MARY CRAWFORD, EXAMINING ATTORNEY

SN 85-313,988. ZELTIQ AESTHETICS, INC., PLEASANTON, CA. FILED 5-6-2011.

COOLSCULPTINGU

THE MARK CONSISTS OF STANDARD CHARACTERS WITHOUT CLAIM TO ANY PARTICULAR FONT, STYLE, SIZE, OR COLOR.

OWNER OF U.S. REG. NOS. 3,921,045 AND 3,957,850.
FOR EDUCATIONAL SERVICES, NAMELY, CONDUCTING CLASSES, SEMINARS AND WORKSHOPS IN COSMETIC MEDICAL PROCEDURE PATIENT IDENTIFICATION, SCREENING AND TREATMENT; TRAINING OF HEALTHCARE PROVIDERS IN THE USE OF MEDICAL DEVICES USED TO DESTROY FAT CELLS AND FOR TISSUE CONTOURING AND CELLULITE IMPROVEMENT (U.S. CLS. 100, 101 AND 107).

FIRST USE 4-15-2011; IN COMMERCE 4-15-2011.
MARIA-VICTORIA SUAREZ, EXAMINING ATTORNEY

CLASS 41—(Continued).

SN 85-314,441. ZELTIQ AESTHETICS, INC., PLEASANTON, CA. FILED 5-6-2011.



OWNER OF U.S. REG. NOS. 3,921,045 AND 3,957,850. THE COLOR(S) BLUE, WHITE AND BLACK IS/ARE CLAIMED AS A FEATURE OF THE MARK.

THE MARK CONSISTS OF A BLUE CIRCLE WITH A WHITE LETTER "U" BESIDE THE WORD "COOLSCULPTING" IN BLACK.

FOR EDUCATIONAL SERVICES, NAMELY, CONDUCTING CLASSES, SEMINARS AND WORKSHOPS IN COSMETIC MEDICAL PROCEDURE PATIENT IDENTIFICATION, SCREENING AND TREATMENT; TRAINING OF HEALTHCARE PROVIDERS IN THE USE OF MEDICAL DEVICES USED TO DESTROY FAT CELLS AND FOR TISSUE CONTOURING AND CELLULITE IMPROVEMENT (U.S. CLS. 100, 101 AND 107).

FIRST USE 4-15-2011; IN COMMERCE 4-15-2011.

MARIA-VICTORIA SUAREZ, EXAMINING ATTORNEY

SN 85-317,372. UNIVISION COMMUNICATIONS INC., LOS ANGELES, CA. FILED 5-10-2011.

EL GORDO Y LA FLACA

THE MARK CONSISTS OF STANDARD CHARACTERS WITHOUT CLAIM TO ANY PARTICULAR FONT, STYLE, SIZE, OR COLOR.

OWNER OF U.S. REG. NO. 2,361,616.

THE ENGLISH TRANSLATION OF "EL GORDO Y LA FLACA" IN THE MARK IS "THE FAT AND THE THIN".

FOR ENTERTAINMENT SERVICES, NAMELY, AN ONGOING GOSSIP TELEVISION PROGRAM (U.S. CLS. 100, 101 AND 107).

FIRST USE 5-7-1998; IN COMMERCE 5-7-1998. ZACHARY BELLO, EXAMINING ATTORNEY

SN 85-317,891. THE PLAYLIST GENERATION, LOS ANGELES, CA. FILED 5-11-2011.

THE PLAYLIST GENERATION

THE MARK CONSISTS OF STANDARD CHARACTERS WITHOUT CLAIM TO ANY PARTICULAR FONT, STYLE, SIZE, OR COLOR.

NO CLAIM IS MADE TO THE EXCLUSIVE RIGHT TO USE "PLAYLIST", APART FROM THE MARK AS SHOWN.

FOR ENTERTAINMENT IN THE NATURE OF LIVE MUSIC REMIXING AND LIVE DJ PERFORMANCES; MUSIC SELECTION SERVICES FOR USE IN TELEVISION, FILM, RADIO, LIVE EVENTS, AND VIDEO GAMES (U.S. CLS. 100, 101 AND 107).

FIRST USE 6-1-2009; IN COMMERCE 6-1-2009.

TINA MAI, EXAMINING ATTORNEY

CLASS 41—(Continued).

SN 85-318,584. ARES TRADING S.A., AUBONNE CH-1170, SWITZERLAND, FILED 5-11-2011.

MS: AN EXCHANGE IN PATIENT MANAGEMENT

THE MARK CONSISTS OF STANDARD CHARACTERS WITHOUT CLAIM TO ANY PARTICULAR FONT, STYLE, SIZE, OR COLOR.

FOR EDUCATIONAL SERVICES, NAMELY, CONDUCTING WORKSHOPS AND JOURNAL CLUBS IN THE FIELD OF HEALTH CARE AND DISTRIBUTION OF SCIENTIFIC ARTICLES IN CONNECTION THEREWITH (U.S. CLS. 100, 101 AND 107).

LINDA ESTRADA, EXAMINING ATTORNEY

SN 85-320,785. THE TRAVEL CHANNEL, L.L.C., CHEVY CHASE, MD. FILED 5-13-2011.

TRIPLE RUSH

THE MARK CONSISTS OF STANDARD CHARACTERS WITHOUT CLAIM TO ANY PARTICULAR FONT, STYLE, SIZE, OR COLOR.

FOR ENTERTAINMENT SERVICES IN THE NATURE OF A CONTINUING NON-FICTION PROGRAM ABOUT MESSENGER SERVICES, ACCESSIBLE BY RADIO, TELEVISION, CABLE, FIBER OPTIC NETWORKS, WIRELESS NETWORKS, SATELLITE, AUDIO VIDEO, AND COMPUTER NETWORKS (U.S. CLS. 100, 101 AND 107).

FIRST USE 4-14-2011; IN COMMERCE 4-14-2011.

DAVID I, EXAMINING ATTORNEY

SN 85-320,788. THE TRAVEL CHANNEL, L.L.C., CHEVY CHASE, MD. FILED 5-13-2011.

MYSTERIES AT THE MUSEUM

THE MARK CONSISTS OF STANDARD CHARACTERS WITHOUT CLAIM TO ANY PARTICULAR FONT, STYLE, SIZE, OR COLOR.

FOR ENTERTAINMENT SERVICES IN THE NATURE OF A CONTINUING NON-FICTION PROGRAM ABOUT HISTORY, CULTURE, ART AND SCIENCE, ACCESSIBLE BY RADIO, TELEVISION, CABLE, FIBER OPTIC NETWORKS, WIRELESS NETWORKS, SATELLITE, AUDIO VIDEO, AND COMPUTER NETWORKS (U.S. CLS. 100, 101 AND 107).

FIRST USE 11-2-2010; IN COMMERCE 11-2-2010.

DAVID I, EXAMINING ATTORNEY

CLASS 41—(Continued).

SN 85-320,797. THE TRAVEL CHANNEL, L.L.C., CHEVY CHASE, MD. FILED 5-13-2011.

WHEN VACATIONS ATTACK!

THE MARK CONSISTS OF STANDARD CHARACTERS WITHOUT CLAIM TO ANY PARTICULAR FONT, STYLE, SIZE, OR COLOR.

FOR ENTERTAINMENT SERVICES IN THE NATURE OF A CONTINUING NON-FICTION PROGRAM ABOUT TRAVEL AND ADVENTURE, ACCESSIBLE BY RADIO, TELEVISION, CABLE, FIBER OPTIC NETWORKS, WIRELESS NETWORKS, SATELLITE, AUDIO VIDEO, AND COMPUTER NETWORKS (U.S. CLS. 100, 101 AND 107).

FIRST USE 11-28-2010; IN COMMERCE 11-28-2010.
DAVID I, EXAMINING ATTORNEY

SN 85-320,806. THE TRAVEL CHANNEL, L.L.C., CHEVY CHASE, MD. FILED 5-13-2011.

MAN V. FOOD

THE MARK CONSISTS OF STANDARD CHARACTERS WITHOUT CLAIM TO ANY PARTICULAR FONT, STYLE, SIZE, OR COLOR.

FOR ENTERTAINMENT SERVICES IN THE NATURE OF A CONTINUING NON-FICTION PROGRAM ABOUT TRAVEL, LOCAL ATTRACTIONS, CULTURE AND CUISINE, ACCESSIBLE BY RADIO, TELEVISION, CABLE, FIBER OPTIC NETWORKS, WIRELESS NETWORKS, SATELLITE, AUDIO VIDEO, AND COMPUTER NETWORKS (U.S. CLS. 100, 101 AND 107).

FIRST USE 12-3-2008; IN COMMERCE 12-3-2008.
DAVID I, EXAMINING ATTORNEY

SN 85-321,332. YOLANDA ADAMS, HOUSTON, TX. FILED 5-15-2011.

Yolanda Adams Radio Network

THE MARK CONSISTS OF STANDARD CHARACTERS WITHOUT CLAIM TO ANY PARTICULAR FONT, STYLE, SIZE, OR COLOR.

OWNER OF U.S. REG. NO. 3,532,968.
NO CLAIM IS MADE TO THE EXCLUSIVE RIGHT TO USE "RADIO NETWORK", APART FROM THE MARK AS SHOWN.

THE NAME "YOLANDA ADAMS" IDENTIFIES A LIVING INDIVIDUAL WHOSE CONSENT IS OF RECORD.

FOR RADIO ENTERTAINMENT SERVICES, NAMELY, RADIO PROGRAMS FEATURING PERFORMANCES BY A RADIO PERSONALITY (U.S. CLS. 100, 101 AND 107).
APRIL HESIK, EXAMINING ATTORNEY

CLASS 41—(Continued).

SN 85-321,723. UNIVISION COMMUNICATIONS INC., LOS ANGELES, CA. FILED 5-16-2011.

RETRO JA JA

THE MARK CONSISTS OF STANDARD CHARACTERS WITHOUT CLAIM TO ANY PARTICULAR FONT, STYLE, SIZE, OR COLOR.

THE ENGLISH TRANSLATION OF "RETRO JA JA" IN THE MARK IS "RETRO HA HA".

FOR ENTERTAINMENT SERVICES, NAMELY, AN ONGOING TELEVISION COMEDY PROGRAM (U.S. CLS. 100, 101 AND 107).

ZACHARY BELLO, EXAMINING ATTORNEY

SN 85-322,011. KHOURY, NICOLE I., TOLEDO, OH. FILED 5-16-2011.

Arctic Clam

THE MARK CONSISTS OF STANDARD CHARACTERS WITHOUT CLAIM TO ANY PARTICULAR FONT, STYLE, SIZE, OR COLOR.

FOR ENTERTAINMENT SERVICES IN THE NATURE OF LIVE MUSICAL PERFORMANCES (U.S. CLS. 100, 101 AND 107).

FIRST USE 3-15-2006; IN COMMERCE 3-15-2006.
STEVEN JACKSON, EXAMINING ATTORNEY

SN 85-322,023. THE CURATORS OF THE UNIVERSITY OF MISSOURI, COLUMBIA, MO. FILED 5-16-2011.

LACE

THE MARK CONSISTS OF STANDARD CHARACTERS WITHOUT CLAIM TO ANY PARTICULAR FONT, STYLE, SIZE, OR COLOR.

FOR EDUCATIONAL SERVICES NAMELY CONDUCTING WORKSHOPS AND SEMINARS IN THE FIELD OF PROFESSIONAL DEVELOPMENT FOR SCHOOL ADMINISTRATORS (U.S. CLS. 100, 101 AND 107).

FIRST USE 12-16-1998; IN COMMERCE 12-16-1998.
ODESSA BIBBINS, EXAMINING ATTORNEY

CLASS 41—(Continued).

SN 85-323,659. IMPRESARIO'S FESTIVITIES LLC, CHICAGO, IL. FILED 5-18-2011.

BECOME HISTORY

THE MARK CONSISTS OF STANDARD CHARACTERS WITHOUT CLAIM TO ANY PARTICULAR FONT, STYLE, SIZE, OR COLOR.
FOR PRESENTATION OF MUSICAL PERFORMANCE (U.S. CLS. 100, 101 AND 107).
SEAN CROWLEY, EXAMINING ATTORNEY

SN 85-324,003. INGRIDIENTS, INC., ANNAPOLIS, MD. FILED 5-18-2011.

NUTRIBOWL

THE MARK CONSISTS OF STANDARD CHARACTERS WITHOUT CLAIM TO ANY PARTICULAR FONT, STYLE, SIZE, OR COLOR.
FOR EDUCATIONAL AND ENTERTAINMENT SERVICES, NAMELY, CONDUCTING ACADEMIC COMPETITIONS IN THE FIELD OF NUTRITION IN THE NATURE OF HEALTH AND DISEASE, AGRICULTURE, FOOD PREPARATION, FOOD SAFETY, DIET, AND ANTHROPOLOGY OF FOOD AND DISTRIBUTION OF COURSE MATERIALS IN CONNECTION THEREWITH, AND EDUCATION CONSULTING RELATED THERETO (U.S. CLS. 100, 101 AND 107).
FIRST USE 4-1-2011; IN COMMERCE 4-1-2011.
CHRISIE B. KING, EXAMINING ATTORNEY

SN 85-324,531. WE: WOMEN'S ENTERTAINMENT LLC, NEW YORK, NY. FILED 5-19-2011.

BRAXTON FAMILY VALUES

THE MARK CONSISTS OF STANDARD CHARACTERS WITHOUT CLAIM TO ANY PARTICULAR FONT, STYLE, SIZE, OR COLOR.
FOR ENTERTAINMENT SERVICES IN THE NATURE OF AN ON-GOING REALITY BASED TELEVISION PROGRAM (U.S. CLS. 100, 101 AND 107).
FIRST USE 1-7-2011; IN COMMERCE 4-12-2011.
SOPHIA S. KIM, EXAMINING ATTORNEY

CLASS 41—(Continued).

SN 85-326,837. MARK CRISTIANO, STILLWATER, OK. FILED 5-22-2011.

VenueRock

THE MARK CONSISTS OF STANDARD CHARACTERS WITHOUT CLAIM TO ANY PARTICULAR FONT, STYLE, SIZE, OR COLOR.
FOR ENTERTAINMENT INFORMATION; ENTERTAINMENT SERVICES, NAMELY, PROVIDING ONLINE REVIEWS OF ENTERTAINMENT VENUES, SUCH AS ARENAS OR CONCERT HALLS, IN ORDER TO INCREASE THE ENJOYMENT OF THE EVENT AT THE SPECIFIC VENUE; PROVIDING A WEB SITE WHERE USERS CAN POST RATINGS, REVIEWS AND RECOMMENDATIONS ON EVENTS AND ACTIVITIES IN THE FIELD OF ENTERTAINMENT AND EDUCATION; PROVIDING A WEBSITE FEATURING ENTERTAINMENT INFORMATION (U.S. CLS. 100, 101 AND 107).
FIRST USE 5-9-2011; IN COMMERCE 5-9-2011.
DAVID C. REIHNER, EXAMINING ATTORNEY

SN 85-352,643. THE OSAGE TRIBE OF OKLAHOMA, PAWHUSKA, OK. FILED 6-22-2011.



The logo for Osage Casino features the word "Osage" in a large, stylized, cursive script font. Below it, the word "CASINO" is written in a smaller, bold, sans-serif, all-caps font.

OWNER OF U.S. REG. NO. 3,831,920.
NO CLAIM IS MADE TO THE EXCLUSIVE RIGHT TO USE "CASINO", APART FROM THE MARK AS SHOWN.
THE MARK CONSISTS OF A STYLIZED "O" WITH THE WORDS "OSAGE CASINO".
FOR ARRANGING AND CONDUCTING SPECIAL EVENTS FOR SOCIAL ENTERTAINMENT PURPOSES; GAMING SERVICES IN THE NATURE OF CASINO GAMING (U.S. CLS. 100, 101 AND 107).
KATHY DE JONGE, EXAMINING ATTORNEY

CLASS 42—SCIENTIFIC AND COMPUTER SERVICES

SN 76-706,779. BONUS OF AMERICA, INC., MCALESTER, OK. FILED 3-14-2011.

MYADMIN

THE MARK CONSISTS OF STANDARD CHARACTERS WITHOUT CLAIM TO ANY PARTICULAR FONT, STYLE, SIZE, OR COLOR.

FOR COMPUTER SERVICES, NAMELY, ACTING AS AN APPLICATION SERVICE PROVIDER IN THE FIELD OF INFORMATION MANAGEMENT TO HOST COMPUTER APPLICATION SOFTWARE FOR THE PURPOSE OF MANAGING ACCOUNTING, REVENUE, BILLING AND TAXES FOR COMMERCIAL CLEANING BUSINESSES (U.S. CLS. 100 AND 101).

FIRST USE 1-16-2011; IN COMMERCE 2-23-2011.
TINA L. SNAPP, EXAMINING ATTORNEY

SN 76-707,216. ODYSSEA GLOBAL COMMUNICATIONS CORP., WOODSIDE, NY. FILED 4-11-2011.

ODYSSEA

THE MARK CONSISTS OF STANDARD CHARACTERS WITHOUT CLAIM TO ANY PARTICULAR FONT, STYLE, SIZE, OR COLOR.

THE WORDING ODYSSEA HAS NO MEANING IN A FOREIGN LANGUAGE.

FOR DESIGN, DEVELOPMENT AND ENGINEERING OF WIRELESS, WIRE-LINE AND OTHER COMMUNICATIONS AND CONTROL FACILITIES AND SYSTEMS (U.S. CLS. 100 AND 101).

FIRST USE 8-7-1997; IN COMMERCE 8-7-1997.
WARREN L. OLANDRIA, EXAMINING ATTORNEY

SN 77-292,260. SIERRA MERCHANT SERVICES, NEW YORK, NY. FILED 9-29-2007.

mypie

THE MARK CONSISTS OF STANDARD CHARACTERS WITHOUT CLAIM TO ANY PARTICULAR FONT, STYLE, SIZE, OR COLOR.

FOR COMPUTER SERVICES, NAMELY, HOSTING AND MAINTAINING AN ONLINE WEBSITE FOR OTHERS TO RECORD AND MANAGE PERSONAL INFORMATION (U.S. CLS. 100 AND 101).

MATTHEW KLINE, EXAMINING ATTORNEY

CLASS 42—(Continued).

SN 77-507,518. CONDUCTOR, INC., NEW YORK, NY. FILED 6-25-2008.

LINKCONDUCTOR

THE MARK CONSISTS OF STANDARD CHARACTERS WITHOUT CLAIM TO ANY PARTICULAR FONT, STYLE, SIZE, OR COLOR.

FOR SEARCH ENGINE OPTIMIZATION AND INTELLIGENCE SERVICES FOR SEARCH ENGINE OPTIMIZATION PROFESSIONALS, NAMELY, RESEARCHING, TRACKING, ANALYZING, MONITORING AND OPTIMIZING SEARCH ENGINE RESULTS AND WEBSITE VISIBILITY TO IMPROVE INCLUSION AND PROMINENCE IN INTERNET SEARCH ENGINE RESULTS; PROVIDING ON-LINE SEARCH ENGINE INTELLIGENCE SOFTWARE, NAMELY, NON-DOWNLOADABLE SOFTWARE USED FOR TRACKING, ANALYZING, MONITORING, AND OPTIMIZING SEARCH ENGINE RESULTS AND WEBSITE VISIBILITY TO IMPROVE INCLUSION AND PROMINENCE IN INTERNET SEARCH ENGINE RESULTS (U.S. CLS. 100 AND 101).

MAYUR VAGHANI, EXAMINING ATTORNEY

SN 77-537,444. RIPPLEIT, LLC, ATLANTA, GA. FILED 8-1-2008.

ripple ☺

THE MARK CONSISTS OF THE WORD "RIPPLE" FOLLOWED BY A ROUND SMILEY FACE WITH TWO EYES, CURVED LIPS, AND NO NOSE.

FOR TECHNICAL SUPPORT SERVICES FOR COMPUTERS AND COMPUTER NETWORKS, NAMELY, DIAGNOSIS OF COMPUTER HARDWARE, SOFTWARE, AND NETWORK PROBLEMS, PROVIDED IN PERSON, BY TELEPHONE, AND BY MEANS OF A GLOBAL COMPUTER NETWORK; INSTALLATION, UPDATING, MAINTENANCE, AND REPAIR OF COMPUTER SOFTWARE FOR OTHERS, PROVIDED IN PERSON, BY TELEPHONE, AND BY MEANS OF A GLOBAL COMPUTER NETWORK; CONSULTING SERVICES IN THE FIELD OF DESIGN, SELECTION, IMPLEMENTATION, AND USE OF COMPUTER HARDWARE, SOFTWARE, AND NETWORKS FOR OTHERS, PROVIDED IN PERSON, BY TELEPHONE, AND BY MEANS OF A GLOBAL COMPUTER NETWORK (U.S. CLS. 100 AND 101).

FIRST USE 1-1-2006; IN COMMERCE 1-1-2006.
KRISTIN CARLSON, EXAMINING ATTORNEY

CLASS 42—(Continued).

SN 77-610,849. OZNET SYSTEMS, INC., SANTA CLARITA, CA. FILED 11-10-2008.



NO CLAIM IS MADE TO THE EXCLUSIVE RIGHT TO USE "SYSTEMS, INC." AND "SUSTAINABLE IT SOLUTIONS" AND "THE ECO-FRIENDLY IT COMPANY", APART FROM THE MARK AS SHOWN.

THE COLOR(S) BLUE AND BLACK IS/ARE CLAIMED AS A FEATURE OF THE MARK.

THE MARK CONSISTS OF THE STYLIZED WORDS "OZNET SYSTEMS, INC. SUSTAINABLE IT SOLUTIONS" IN BLUE WITH A BLUE LINE SEPARATING THE "OZNET SYSTEMS, INC." WORDING FROM THE "SUSTAINABLE IT SOLUTIONS" WORDING. AROUND THE LETTERS "OZ" IS AN IMAGE OF THREE WAVES IN BLUE. THE WORDING "THE ECO-FRIENDLY IT COMPANY" APPEARS AT THE BOTTOM OF THE MARK IN BLACK.

FOR CONSULTING SERVICES IN THE FIELD OF INFORMATION TECHNOLOGY, NAMELY, IN THE FIELDS OF COMPUTER DISASTER DATA RECOVERY AND CONVERSION OF DATA OR DOCUMENTS FROM PHYSICAL TO ELECTRONIC MEDIA (U.S. CLS. 100 AND 101).

FIRST USE 2-9-2005; IN COMMERCE 2-9-2005.
DANIEL CAPSHAW, EXAMINING ATTORNEY

CLASS 42—(Continued).

SN 77-871,342. FUGRO AIRBORNE SURVEYS CORP., MISSISSAUGA, ONTARIO, CANADA, FILED 11-12-2009.

TEMPEST

THE MARK CONSISTS OF STANDARD CHARACTERS WITHOUT CLAIM TO ANY PARTICULAR FONT, STYLE, SIZE, OR COLOR.

PRIORITY CLAIMED UNDER SEC. 44(D) ON CANADA APPLICATION NO. 1458363, FILED 11-9-2009, REG. NO. TMA788,002, DATED 1-19-2011, EXPIRES 1-19-2026.

FOR PROVIDING AIRBORNE ELECTROMAGNETIC SURVEYING; PROVIDING AIRBORNE ELECTROMAGNETIC SURVEYING DATA, AND ANALYZING AIRBORNE ELECTROMAGNETIC SURVEYING DATA; CONDUCTING GEOPHYSICAL SURVEYS (U.S. CLS. 100 AND 101).

MARIA-VICTORIA SUAREZ, EXAMINING ATTORNEY

SN 77-844,394. ZYMEWORKS INC., VANCOUVER, CANADA, FILED 10-8-2009.

zymeworks

THE MARK CONSISTS OF STANDARD CHARACTERS WITHOUT CLAIM TO ANY PARTICULAR FONT, STYLE, SIZE, OR COLOR.

PRIORITY CLAIMED UNDER SEC. 44(D) ON CANADA APPLICATION NO. 1436477, FILED 4-29-2009, REG. NO. TMA764,310, DATED 4-15-2010, EXPIRES 4-15-2025.

THE WORDING "ZYMEWORKS" HAS NO MEANING IN A FOREIGN LANGUAGE.

FOR CHEMICAL MOLECULAR ANALYSIS AND PRODUCT OPTIMIZATION, NAMELY, PRODUCT RESEARCH AND DEVELOPMENT FOR OTHERS, PROVIDED TO PHARMACEUTICAL, BIOTECHNOLOGY AND CHEMICAL INDUSTRIES USING PROPRIETARY SOFTWARE, ANALYTICAL TOOLS AND ALGORITHMS (U.S. CLS. 100 AND 101).

FIRST USE 6-1-2008; IN COMMERCE 6-1-2008.
MYRIAH HABEEB, EXAMINING ATTORNEY

SN 77-871,377. FUGRO AIRBORNE SURVEYS CORP., MISSISSAUGA, ONTARIO, CANADA, FILED 11-12-2009.

HELIGEOTEM

THE MARK CONSISTS OF STANDARD CHARACTERS WITHOUT CLAIM TO ANY PARTICULAR FONT, STYLE, SIZE, OR COLOR.

PRIORITY CLAIMED UNDER SEC. 44(D) ON CANADA APPLICATION NO. 1458367, FILED 11-9-2009, REG. NO. TMA785,142, DATED 12-16-2010, EXPIRES 12-16-2025.

OWNER OF U.S. REG. NO. 2,221,577.

FOR PROVIDING AIRBORNE ELECTROMAGNETIC SURVEYING; PROVIDING AIRBORNE ELECTROMAGNETIC SURVEYING DATA, AND ANALYZING AIRBORNE ELECTROMAGNETIC SURVEYING DATA; CONDUCTING GEOPHYSICAL SURVEYS (U.S. CLS. 100 AND 101).

MARIA-VICTORIA SUAREZ, EXAMINING ATTORNEY

CLASS 42—(Continued).

SN 77-871,395. FUGRO AIRBORNE SURVEYS CORP., MISSISSAUGA, ONTARIO, CANADA, FILED 11-12-2009.

RESOLVE

THE MARK CONSISTS OF STANDARD CHARACTERS WITHOUT CLAIM TO ANY PARTICULAR FONT, STYLE, SIZE, OR COLOR.

PRIORITY CLAIMED UNDER SEC. 44(D) ON CANADA APPLICATION NO. 1458368, FILED 11-9-2009, REG. NO. TMA785,141, DATED 12-16-2010, EXPIRES 12-16-2025.

FOR PROVIDING AIRBORNE ELECTROMAGNETIC SURVEYING; PROVIDING AIRBORNE ELECTROMAGNETIC SURVEYING DATA, AND ANALYZING AIRBORNE ELECTROMAGNETIC SURVEYING DATA; CONDUCTING GEOPHYSICAL SURVEYS (U.S. CLS. 100 AND 101).

MARIA-VICTORIA SUAREZ, EXAMINING ATTORNEY

SN 77-953,820. TRAFFIC INC., COSTA MESA, CA. FILED 3-9-2010.

TRAFFIC DRIVEN

THE MARK CONSISTS OF STANDARD CHARACTERS WITHOUT CLAIM TO ANY PARTICULAR FONT, STYLE, SIZE, OR COLOR.

NO CLAIM IS MADE TO THE EXCLUSIVE RIGHT TO USE "TRAFFIC", APART FROM THE MARK AS SHOWN.

FOR COMPUTER AND SOFTWARE SERVICES, NAMELY, PROVIDING OF ONLINE, NON-DOWNLOADABLE SOFTWARE FOR AUTOMOBILE DEALERSHIP MANAGEMENT, NAMELY, TRACKING VEHICLE INVENTORY, TRACKING SALES, FINANCE AND INSURANCE CALCULATIONS TRACKING CUSTOMERS AND CUSTOMER FOLLOW UP, MANAGING DEALER WEBSITES, CALCULATING EMPLOYEE COMMISSIONS, PURCHASE ORDER TRACKING, PARTS INVENTORY MANAGEMENT, WORK ORDER MANAGEMENT, APPOINTMENT SCHEDULING IN THE FIELDS OF INTERNET BASED BUSINESS MANAGEMENT, WORLD WIDE WEB PORTAL FOR TRANSPORTATION MANAGEMENT, INTERNET COMMUNITY, DEALERSHIP MANAGEMENT, CLOUD COMPUTING FOR CONSUMERS AND BUSINESSES (U.S. CLS. 100 AND 101).

MYRIAH HABEEB, EXAMINING ATTORNEY

CLASS 42—(Continued).

SN 77-958,103. WOOD R AND D LTD, DBA WOOD RESEARCH AND DEVELOPMENT, CORVALLIS, OR. FILED 3-12-2010.



THE MARK CONSISTS OF THE LETTERS "WRD" ENCLOSED IN AN OVAL.

FOR INSPECTION, QUANTITY AND QUALITY CONTROL, SUPERVISION AND VERIFICATION OF THE QUALITY AND QUANTITY OF RAW MATERIALS, COMMODITIES, MANUFACTURED, SEMI-MANUFACTURED AND TRANSFORMED GOODS OR GOODS OF ANY OTHER NATURE AND THEIR CONFORMITY WITH NATIONAL AND INTERNATIONAL NORMS, LAWS, RULES, PRACTICE AND STANDARDS AND WITH CLIENTS' CONTRACTUAL REQUIREMENTS (U.S. CLS. 100 AND 101).

FIRST USE 3-12-2010; IN COMMERCE 3-12-2010.
BERYL GARDNER, EXAMINING ATTORNEY

SN 78-785,959. APPLE INC., CUPERTINO, CA. FILED 1-5-2006.

MOBILE ME

THE MARK CONSISTS OF STANDARD CHARACTERS WITHOUT CLAIM TO ANY PARTICULAR FONT, STYLE, SIZE, OR COLOR.

PRIORITY CLAIMED UNDER SEC. 44(D) ON HONG KONG APPLICATION NO. 300452510, FILED 7-6-2005.

FOR WEBSITE HOSTING SERVICES FOR OTHERS; PROVIDING USE OF ON-LINE, NON-DOWNLOADABLE SOFTWARE, NAMELY, SOFTWARE USED TO ACCESS, OPERATE, AND COMMUNICATE WITH DIGITAL AUDIO, DIGITAL VIDEO, AND MP3 PLAYERS, SOFTWARE FOR PERSONAL INFORMATION MANAGEMENT, DATABASE MANAGEMENT SOFTWARE, ELECTRONIC MAIL AND MESSAGING SOFTWARE, DATABASE SYNCHRONIZATION SOFTWARE, SOFTWARE FOR THE REDIRECTION OF MESSAGES, EMAIL, AND/OR OTHER DATA TO ONE OR MORE HANDHELD ELECTRONIC DEVICES, SOFTWARE FOR COMMUNICATIONS VIA LOCAL OR GLOBAL COMMUNICATIONS NETWORKS, NAMELY, THE INTERNET, INTRANETS, EXTRANETS, TELEVISION, MOBILE COMMUNICATION, CELLULAR AND SATELLITE NETWORKS (U.S. CLS. 100 AND 101).

FIRST USE 6-9-2008; IN COMMERCE 7-11-2008.
AMY C. KEAN, EXAMINING ATTORNEY

CLASS 42—(Continued).

SN 79-089,104. IPSEN PHARMA S.A.S., FRANCE, FILED 10-14-2010.



PRIORITY DATE OF 7-26-2010 IS CLAIMED.
OWNER OF INTERNATIONAL REGISTRATION 1056075 DATED 10-14-2010, EXPIRES 10-14-2020.

THE COLOR(S) BLACK, ORANGE, YELLOW AND RED IS/ARE CLAIMED AS A FEATURE OF THE MARK.

THE MARK CONSISTS OF THE WORD "TULIPIA" IN BLACK TO THE LEFT OF THE DESIGN COMPRISED OF THREE CURVED LINES. THE FIRST LINE IS IN THE COLORS ORANGE AND YELLOW, THE SECOND IS IN BLACK AND THE LAST IS IN RED.

THE ENGLISH TRANSLATION OF "TULIPIA" IN THE MARK IS "TULIP / TULIP TREE".

FOR PROGRAM OF MEDICAL AND SCIENTIFIC STUDIES, NAMELY, SCIENTIFIC INVESTIGATIONS FOR MEDICAL PURPOSES; MEDICAL AND SCIENTIFIC RESEARCH, NAMELY, CONDUCTING CLINICAL TRIALS, STUDIES AND ANALYSES; MEDICAL AND SCIENTIFIC RESEARCH (U.S. CLS. 100 AND 101).

JAMES LOVELACE, EXAMINING ATTORNEY

SN 79-089,288. IPSEN PHARMA S.A.S., FRANCE, FILED 10-14-2010.

TULIPIA

THE MARK CONSISTS OF STANDARD CHARACTERS WITHOUT CLAIM TO ANY PARTICULAR FONT, STYLE, SIZE, OR COLOR.

PRIORITY DATE OF 7-26-2010 IS CLAIMED.
OWNER OF INTERNATIONAL REGISTRATION 1056503 DATED 10-14-2010, EXPIRES 10-14-2020.

THE ENGLISH TRANSLATION OF "TULIPIA" IN THE MARK IS "TULIP / TULIP TREE".

FOR PROGRAM OF MEDICAL AND SCIENTIFIC STUDIES, NAMELY, SCIENTIFIC INVESTIGATIONS FOR MEDICAL PURPOSES; MEDICAL AND SCIENTIFIC RESEARCH, NAMELY, CONDUCTING CLINICAL TRIALS, STUDIES AND ANALYSES; MEDICAL AND SCIENTIFIC RESEARCH (U.S. CLS. 100 AND 101).

JAMES LOVELACE, EXAMINING ATTORNEY

CLASS 42—(Continued).

SN 85-016,036. KENNEY, GERRARD FRANCIS, STATE COLLEGE, PA. FILED 4-16-2010.

Symbylogic Because Time Matters

THE MARK CONSISTS OF STANDARD CHARACTERS WITHOUT CLAIM TO ANY PARTICULAR FONT, STYLE, SIZE, OR COLOR.

FOR PROVIDING TEMPORARY USE OF NON-DOWNLOADABLE COMPUTER SOFTWARE FOR HEALTH-CARE MANAGEMENT, NAMELY, FOR INTERDEPARTMENTAL DATA SHARING (U.S. CLS. 100 AND 101).

JANICE KIM, EXAMINING ATTORNEY

SN 85-081,957. INTELILINKS LLC, DEARBORN, MI. FILED 7-10-2010.

JANVOO

THE MARK CONSISTS OF STANDARD CHARACTERS WITHOUT CLAIM TO ANY PARTICULAR FONT, STYLE, SIZE, OR COLOR.

THE NAME(S), PORTRAIT(S), AND/OR SIGNATURE(S) SHOWN IN THE MARK DOES NOT IDENTIFY A PARTICULAR LIVING INDIVIDUAL.

FOR COMPUTER SERVICES, NAMELY, PROVIDING AN ON-LINE INTERNET SEARCH ENGINE SOFTWARE (U.S. CLS. 100 AND 101).

MICHAEL WEBSTER, EXAMINING ATTORNEY

SN 85-102,874. VARONIS SYSTEMS, INC., NEW YORK, NY. FILED 8-9-2010.

VARONIS METADATA FRAMEWORK

THE MARK CONSISTS OF STANDARD CHARACTERS WITHOUT CLAIM TO ANY PARTICULAR FONT, STYLE, SIZE, OR COLOR.

OWNER OF U.S. REG. NOS. 3,364,932 AND 3,371,874.
NO CLAIM IS MADE TO THE EXCLUSIVE RIGHT TO USE "METADATA FRAMEWORK", APART FROM THE MARK AS SHOWN.

FOR DATA AUTOMATION AND COLLECTION SERVICE USING PROPRIETARY SOFTWARE TO EVALUATE, ANALYZE, AUDIT AND COLLECT DATA (U.S. CLS. 100 AND 101).

FIRST USE 9-0-2009; IN COMMERCE 9-0-2009.

LAURIE MAYES, EXAMINING ATTORNEY

CLASS 42—(Continued).

SN 85-112,024. XSPORTURE LLC, ATLANTA, GA. FILED 8-20-2010.

XSPORTURE

THE MARK CONSISTS OF STANDARD CHARACTERS WITHOUT CLAIM TO ANY PARTICULAR FONT, STYLE, SIZE, OR COLOR.

FOR COMPUTER SERVICES, NAMELY, HOSTING ONLINE WEB FACILITIES FOR OTHERS FOR ORGANIZING AND CONDUCTING ONLINE MEETINGS, GATHERINGS, AND INTERACTIVE DISCUSSIONS; AND COMPUTER SERVICES IN THE NATURE OF CUSTOMIZED WEB PAGES FEATURING USER-DEFINED INFORMATION, PERSONAL PROFILES AND INFORMATION; COMPUTER SERVICES, NAMELY, CREATING AN ON-LINE COMMUNITY FOR REGISTERED USERS WHO ARE ATHLETES, FANS, PLAYERS, TEAMS AND LEAGUE PERSONNEL TO PARTICIPATE IN DISCUSSIONS, GET FEEDBACK FROM THEIR PEERS, FORM VIRTUAL COMMUNITIES AND ENGAGE IN SOCIAL NETWORKING ALL FOR ORGANIZING GAME AND SPORTS ACTIVITIES; APPLICATION SERVICE PROVIDER (ASP) FEATURING SOFTWARE TO ENABLE UPLOADING, POSTING, SHOWING, DISPLAYING, TAGGING, BLOGGING, SHARING, OR OTHERWISE PROVIDING ELECTRONIC MEDIA OR INFORMATION OVER THE INTERNET OR OTHER COMMUNICATIONS NETWORK; PROVIDING TEMPORARY USE OF NON-DOWNLOADABLE SOFTWARE APPLICATIONS FOR VIRTUAL COMMUNITY, SOCIAL NETWORKING, PHOTO SHARING, VIDEO SHARING, AND TRANSMISSION OF PHOTOGRAPHIC IMAGES; COMPUTER SERVICES, NAMELY, CREATING AN ON-LINE COMMUNITY FOR REGISTERED USERS TO PARTICIPATE IN DISCUSSION, GET FEEDBACK FROM THEIR PEERS, FORM VIRTUAL COMMUNITIES, AND ENGAGE IN SOCIAL NETWORKING; PEER-TO-BROWSER PHOTO SHARING SERVICES NAMELY, PROVIDING A WEBSITE FEATURING TECHNOLOGY ENABLING USERS TO UPLOAD, VIEW AND DOWNLOAD DIGITAL PHOTOS (U.S. CLS. 100 AND 101).

FIRST USE 7-27-2010; IN COMMERCE 6-1-2011.
WILLIAM VERHOSEK, EXAMINING ATTORNEY

SN 85-113,386. MACROPOINT, LLC, CLEVELAND, OH. FILED 8-23-2010.

MACROPOINT

THE MARK CONSISTS OF STANDARD CHARACTERS WITHOUT CLAIM TO ANY PARTICULAR FONT, STYLE, SIZE, OR COLOR.

FOR PROVIDING TEMPORARY USE OF NON-DOWNLOADABLE COMPUTER SOFTWARE FOR LOCATION TRACKING OF MOBILE ASSETS OVER WIRELESS NETWORKS, AND FOR PROVIDING COMMUNICATIONS, INTEGRATION, AND DIAGNOSTIC TOOLS RELATED TO SAME, NAMELY, THE PROVISION OF TWO-WAY TEXT, DATA, VOICE-MESSAGING, GEO-FENCING, AND VEHICLE ENGINE DIAGNOSTICS SERVICES AND INTEGRATING SUCH ELEMENTS INTO A TRANSPORTATION MANAGEMENT SYSTEM; RENTAL OF RELATED COMPUTER HARDWARE (U.S. CLS. 100 AND 101).

HEATHER THOMPSON, EXAMINING ATTORNEY

CLASS 42—(Continued).

SN 85-117,798. VIEWBOOK B.V., TA VIEWBOOK, ROTTERDAM, NETHERLANDS, FILED 8-27-2010.

viewbook

THE MARK CONSISTS OF STANDARD CHARACTERS WITHOUT CLAIM TO ANY PARTICULAR FONT, STYLE, SIZE, OR COLOR.

FOR PROVIDING ON-LINE NON-DOWNLOADABLE SOFTWARE FOR UPLOADING, DOWNLOADING, TRANSFER, STORAGE, RETRIEVAL, SHARING, DISPLAYING, ARCHIVING, FILE MANAGEMENT, LICENSING, SELLING, ANNOTATING AND STORING DIGITAL IMAGES, PHOTOGRAPHS, VIDEO, AUDIO, AND WORKS OF VISUAL ART AND TEXT FILES; PROVIDING USE OF ON-LINE NON-DOWNLOADABLE SOFTWARE FOR CREATING GALLERIES OF IMAGES, PHOTOGRAPHS, VIDEO, AUDIO, AND WORKS OF VISUAL ART; PROVIDING USE OF ON-LINE NON-DOWNLOADABLE SOFTWARE FOR CREATING AND HOSTING WEB SITES; CREATION, HOSTING AND MAINTENANCE OF INTERNET SITES AND WEBSITES FOR THIRD PARTIES; HOSTING OF DIGITAL CONTENT, IMAGES, PHOTOGRAPHS, VIDEO, AUDIO, AND WORKS OF VISUAL ART AND TEXT FILES ON THE INTERNET; PROVIDING CUSTOMIZED ON-LINE WEB PAGES FEATURING USER-DEFINED INFORMATION, WHICH INCLUDES IMAGES, PHOTOGRAPHS, VIDEO, AUDIO, AND WORKS OF VISUAL ART AND TEXT FILES (U.S. CLS. 100 AND 101).

FIRST USE 7-1-2007; IN COMMERCE 7-1-2007.
ELLEN BURNS, EXAMINING ATTORNEY

SN 85-117,954. SAFETYWEB, INC., AKA SAFETYWEB.COM, DENVER, CO. FILED 8-27-2010.

SWOT Technology

THE MARK CONSISTS OF STANDARD CHARACTERS WITHOUT CLAIM TO ANY PARTICULAR FONT, STYLE, SIZE, OR COLOR.

NO CLAIM IS MADE TO THE EXCLUSIVE RIGHT TO USE "TECHNOLOGY", APART FROM THE MARK AS SHOWN.

FOR PROVIDING A WEBSITE FEATURING A MEDIA AGGREGATOR AND SEARCH ENGINE FOR INTERNET CONTENT (U.S. CLS. 100 AND 101).

JOSETTE BEVERLY, EXAMINING ATTORNEY

CLASS 42—(Continued).

SN 85-127,020. MILITARY WRAPS RESEARCH & DEVELOPMENT, INC., LUMBERTON, NC. FILED 9-10-2010.

CLASS 42—(Continued).

SN 85-128,411. INCONTACT, MIDVALE, UT. FILED 9-13-2010.

ROUTES

THE MARK CONSISTS OF STANDARD CHARACTERS WITHOUT CLAIM TO ANY PARTICULAR FONT, STYLE, SIZE, OR COLOR.

FOR PRODUCT DEVELOPMENT, NAMELY, CUSTOM DESIGN OF TRAINING SYSTEMS FOR MILITARY, LAW ENFORCEMENT, AND/OR FIRST RESPONDER PERSONNEL (U.S. CLS. 100 AND 101).

CHARLOTTE CORWIN, EXAMINING ATTORNEY

INCLOUD

SN 85-127,531. DARENA SOLUTIONS LLC, OFALLON, MO. FILED 9-11-2010.

Darena Solutions

THE MARK CONSISTS OF STANDARD CHARACTERS WITHOUT CLAIM TO ANY PARTICULAR FONT, STYLE, SIZE, OR COLOR.

NO CLAIM IS MADE TO THE EXCLUSIVE RIGHT TO USE "SOLUTIONS", APART FROM THE MARK AS SHOWN.

FOR PROVIDING TEMPORARY USE OF NON-DOWNLOADABLE SOFTWARE AND ONLINE SOFTWARE APPLICATIONS FOR APPLICATION AND DATABASE INTEGRATION, FOR COMPUTER SYSTEM AND APPLICATION DEVELOPMENT, DEPLOYMENT AND MANAGEMENT, FOR CONTROLLING AND MANAGING ACCESS SERVER APPLICATIONS, AND FOR CONTROLLING AND MANAGING PATIENT MEDICAL INFORMATION (U.S. CLS. 100 AND 101).

YAT SYE, LEE, EXAMINING ATTORNEY

THE MARK CONSISTS OF STANDARD CHARACTERS WITHOUT CLAIM TO ANY PARTICULAR FONT, STYLE, SIZE, OR COLOR.

FOR APPLICATION SERVICE PROVIDER FEATURING SOFTWARE FOR QUEUING, HANDLING, LOGGING, RECORDING, MONITORING, TRACKING, SUPERVISING, MANAGING, ROUTING, DISPOSITION AND DISTRIBUTION OF TELEPHONE CALLS, FACSIMILE TRANSMISSIONS, EMAILS, SOCIAL MEDIA, AND WEB BASED MESSAGES TO OR FROM IN OFFICE OR AT HOME EMPLOYEES, CONTRACTORS, SUBCONTRACTORS, PARTIES, CALLERS OR CUSTOMERS FOR USE IN THE FIELD OF CUSTOMER SERVICE, CUSTOMER SUPPORT, INSIDE SALES, COLLECTIONS, OUTSIDE SALES, AND MARKETING, APPLICATION SERVICE PROVIDER FEATURING SOFTWARE FOR SCHEDULING, SURVEYING, MONITORING, SUPERVISING, RATING, REVIEWING MANAGING, FORECASTING, RECORDING, ANALYZING AND TRAINING EMPLOYEES FOR USE IN THE FIELD OF CUSTOMER SERVICE, CUSTOMER SUPPORT, INSIDE SALES, COLLECTIONS, OUTSIDE SALES, AND MARKETING, APPLICATION SERVICE PROVIDER FEATURING AN APPLICATION SOFTWARE DEVELOPMENT TOOL FOR USE IN CUSTOMIZING TELECOMMUNICATION SERVICE APPLICATIONS, NAMELY, SOFTWARE FOR QUEUING, HANDLING, LOGGING, RECORDING, MONITORING, TRACKING, SUPERVISING, MANAGING, ROUTING, DISPOSITION AND DISTRIBUTION OF TELEPHONE CALLS, FACSIMILE TRANSMISSIONS, EMAILS, SOCIAL MEDIA, AND WEB BASED MESSAGES TO OR FROM IN OFFICE OR AT HOME EMPLOYEES, CONTRACTORS, SUBCONTRACTORS, PARTIES, CALLERS OR CUSTOMERS FOR USE IN THE FIELD OF CUSTOMER SERVICE, CUSTOMER SUPPORT, INSIDE SALES, COLLECTIONS, OUTSIDE SALES, AND MARKETING (U.S. CLS. 100 AND 101).

TINA L. SNAPP, EXAMINING ATTORNEY

CLASS 42—(Continued).

SN 85-129,696. XSPORTURE LLC, ATLANTA, GA. FILED 9-14-2010.

CHANGING THE GAME IN SPORTS EXPOSURE

THE MARK CONSISTS OF STANDARD CHARACTERS WITHOUT CLAIM TO ANY PARTICULAR FONT, STYLE, SIZE, OR COLOR.

FOR COMPUTER SERVICES, NAMELY, HOSTING ONLINE WEB FACILITIES FOR OTHERS FOR ORGANIZING AND CONDUCTING ONLINE MEETINGS, GATHERINGS, AND INTERACTIVE DISCUSSIONS; AND COMPUTER SERVICES IN THE NATURE OF CUSTOMIZED WEB PAGES FEATURING USER-DEFINED INFORMATION, PERSONAL PROFILES AND INFORMATION; COMPUTER SERVICES, NAMELY, CREATING AN ON-LINE COMMUNITY FOR REGISTERED USERS WHO ARE ATHLETES, FANS, PLAYERS, TEAMS AND LEAGUE PERSONNEL TO PARTICIPATE IN DISCUSSIONS, GET FEEDBACK FROM THEIR PEERS, FORM VIRTUAL COMMUNITIES AND ENGAGE IN SOCIAL NETWORKING ALL FOR ORGANIZING GAME AND SPORTS ACTIVITIES; APPLICATION SERVICE PROVIDER (ASP) FEATURING SOFTWARE TO ENABLE UPLOADING, POSTING, SHOWING, DISPLAYING, TAGGING, BLOGGING, SHARING, OR OTHERWISE PROVIDING ELECTRONIC MEDIA OR INFORMATION OVER THE INTERNET OR OTHER COMMUNICATIONS NETWORK; PROVIDING TEMPORARY USE OF NON-DOWNLOADABLE SOFTWARE APPLICATIONS FOR VIRTUAL COMMUNITY, SOCIAL NETWORKING, PHOTO SHARING, VIDEO SHARING, AND TRANSMISSION OF PHOTOGRAPHIC IMAGES; COMPUTER SERVICES, NAMELY, CREATING AN ON-LINE COMMUNITY FOR REGISTERED USERS TO PARTICIPATE IN DISCUSSION, GET FEEDBACK FROM THEIR PEERS, FORM VIRTUAL COMMUNITIES, AND ENGAGE IN SOCIAL NETWORKING; PEER-TO-BROWSER PHOTO SHARING SERVICES, NAMELY, PROVIDING A WEBSITE FEATURING TECHNOLOGY ENABLING USERS TO UPLOAD, VIEW AND DOWNLOAD DIGITAL PHOTOS (U.S. CLS. 100 AND 101).

FIRST USE 7-27-2010; IN COMMERCE 6-1-2011.
WILLIAM VERHOSEK, EXAMINING ATTORNEY

SN 85-132,071. AXOLOTL CORPORATION, SAN JOSE, CA. FILED 9-17-2010.

ELYSIUM EXCHANGE

THE MARK CONSISTS OF STANDARD CHARACTERS WITHOUT CLAIM TO ANY PARTICULAR FONT, STYLE, SIZE, OR COLOR.

OWNER OF U.S. REG. NO. 2,560,061.
FOR SOFTWARE AS A SERVICE (SAAS) SERVICES FEATURING SOFTWARE IN THE FIELD OF CONTROLLED ACCESS SERVICE WHICH MAINTAINS DATABASES OF PATIENT HEALTH INFORMATION AND PROVIDES ACCESS TO SUCH INFORMATION TO HEALTH CARE PERSONNEL AND HEALTH CARE INSTITUTIONS (U.S. CLS. 100 AND 101).

H. M. FISHER, EXAMINING ATTORNEY

CLASS 42—(Continued).

SN 85-137,160. SALEHOO GROUP, CHRISTCHURCH, NEW ZEALAND, FILED 9-24-2010.

SaleHoo Stores

THE MARK CONSISTS OF STANDARD CHARACTERS WITHOUT CLAIM TO ANY PARTICULAR FONT, STYLE, SIZE, OR COLOR.

PRIORITY CLAIMED UNDER SEC. 44(D) ON NEW ZEALAND APPLICATION NO. 831009, FILED 9-24-2010, REG. NO. 831009, DATED 9-24-2010, EXPIRES 9-24-2020.

OWNER OF U.S. REG. NO. 3,638,102.

NO CLAIM IS MADE TO THE EXCLUSIVE RIGHT TO USE "STORES", APART FROM THE MARK AS SHOWN.

FOR DESIGNING, CREATING, MAINTAINING AND HOSTING ONLINE RETAIL AND ELECTRONIC COMMERCE WEBSITES FOR OTHERS (U.S. CLS. 100 AND 101).

KATHERINE CHANG, EXAMINING ATTORNEY

SN 85-141,850. STEVE SORENSEN, RUSSELL, PA. FILED 9-30-2010.

The Everyday Hunter

THE MARK CONSISTS OF STANDARD CHARACTERS WITHOUT CLAIM TO ANY PARTICULAR FONT, STYLE, SIZE, OR COLOR.

NO CLAIM IS MADE TO THE EXCLUSIVE RIGHT TO USE "HUNTER", APART FROM THE MARK AS SHOWN.

FOR HOSTING OF WEB SITES (U.S. CLS. 100 AND 101).

FIRST USE 2-26-2005; IN COMMERCE 2-26-2005.

MARGERY A. TIERNEY, EXAMINING ATTORNEY

SN 85-145,881. CROP PRO INC, GRIMES, IA. FILED 10-6-2010.

PROFIT PRO

THE MARK CONSISTS OF STANDARD CHARACTERS WITHOUT CLAIM TO ANY PARTICULAR FONT, STYLE, SIZE, OR COLOR.

FOR SOFTWARE AS A SERVICE (SAAS) SERVICES FEATURING SOFTWARE FOR PROVIDING INSURANCE INFORMATION, INSURANCE QUOTES, AND RISK MANAGEMENT STRATEGIES IN THE FIELD OF AGRICULTURAL FARMING (U.S. CLS. 100 AND 101).

FIRST USE 8-16-2010; IN COMMERCE 8-30-2010.

KIM MONINGHOFF, EXAMINING ATTORNEY

CLASS 42—(Continued).

SN 85-149,766. PARDHE, DANIEL F, PHOENIX, AZ. FILED 10-11-2010.

Tollege

THE MARK CONSISTS OF STANDARD CHARACTERS WITHOUT CLAIM TO ANY PARTICULAR FONT, STYLE, SIZE, OR COLOR.
FOR DESIGN, DEVELOPMENT AND IMPLEMENTATION OF SOFTWARE (U.S. CLS. 100 AND 101).
FIRST USE 9-24-2010; IN COMMERCE 9-24-2010.
MARK SHINER, EXAMINING ATTORNEY

SN 85-158,947. TRUTH, VALUES & LEADERSHIP, INDIANOLA, IA. FILED 10-22-2010.

TRUTH, VALUE & LEADERSHIP

THE MARK CONSISTS OF STANDARD CHARACTERS WITHOUT CLAIM TO ANY PARTICULAR FONT, STYLE, SIZE, OR COLOR.
FOR DEVELOPMENT OF VOLUNTARY STANDARDS FOR CHURCHES AND THEIR ASSOCIATED MEMBERS, LEADERS, AND COMMUNITIES WITH RESPECT TO ISSUES OF BUSINESS, GOVERNMENT AND FINANCE (U.S. CLS. 100 AND 101).
JESSICA A. POWERS, EXAMINING ATTORNEY

CLASS 42—(Continued).

SN 85-160,831. E-SCAN DATA SYSTEMS, INC., AUSTIN, TX. FILED 10-25-2010.



OWNER OF U.S. REG. NO. 3,908,658.
NO CLAIM IS MADE TO THE EXCLUSIVE RIGHT TO USE "DATA SYSTEMS INC", APART FROM THE MARK AS SHOWN.
THE MARK CONSISTS OF THREE SETS OF THREE SEMI-CIRCULAR TAPERED LINES, INTERSECTING THREE TIMES IN A ROUNDED CROSS-HATCH PATTERN, OVER THE WORD "ESCAN" AND OVER THE WORDS "DATA SYSTEMS INC" IN STYLIZED FONT.
FOR PROVIDING TEMPORARY USE OF NON-DOWNLOADABLE SOFTWARE FOR USE IN DETERMINING PATIENT ELIGIBILITY FOR INSURANCE COVERAGE (U.S. CLS. 100 AND 101).
FIRST USE 3-1-2010; IN COMMERCE 3-1-2010.
MARK SPARACINO, EXAMINING ATTORNEY

SN 85-161,548. ONHOLD WORX CORPORATION, EDMOND, OK. FILED 10-26-2010.

WORKS24

THE MARK CONSISTS OF STANDARD CHARACTERS WITHOUT CLAIM TO ANY PARTICULAR FONT, STYLE, SIZE, OR COLOR.
OWNER OF U.S. REG. NO. 3,526,916.
FOR PROVIDING TEMPORARY USE OF ONLINE, NON-DOWNLOADABLE SOFTWARE THAT ENABLES USERS TO CREATE, SCHEDULE, AND MANAGE ONHOLD TELEPHONE MUSIC AND MESSAGES, OVERHEAD MUSIC AND MESSAGES, AND PROMOTIONAL VIDEOS (U.S. CLS. 100 AND 101).
FIRST USE 9-1-2010; IN COMMERCE 9-1-2010.
JAMES GRIFFIN, EXAMINING ATTORNEY

CLASS 42—(Continued).

SN 85-170,162. MOZART NETWORKS, LLC, NEW YORK, NY. FILED 11-5-2010.

Her Mozart

THE MARK CONSISTS OF STANDARD CHARACTERS WITHOUT CLAIM TO ANY PARTICULAR FONT, STYLE, SIZE, OR COLOR.

NO CLAIM IS MADE TO THE EXCLUSIVE RIGHT TO USE "MOZART", APART FROM THE MARK AS SHOWN.

FOR PROVIDING A WEBSITE FEATURING TECHNOLOGY THAT ENABLES USERS TO UPLOAD, EXCHANGE, AND SHARE VIDEO, PHOTOS, AND OTHER FORMS OF MEDIA ON THE INTERNET AND MOBILE DEVICES (U.S. CLS. 100 AND 101).

KATHERINE CHANG, EXAMINING ATTORNEY

SN 85-173,117. XIAMEN MILLION STONE ARTS & CRAFTS CO., LTD., XIAMEN, CHINA, FILED 11-10-2010.



NO CLAIM IS MADE TO THE EXCLUSIVE RIGHT TO USE "STONE ARTS", APART FROM THE MARK AS SHOWN.

THE MARK CONSISTS OF AN EAGLE'S HEAD WITH THREE ENGLISH WORDS BENEATH.

FOR AUTHENTICATING WORKS OF ART; CONSULTING SERVICES IN THE FIELD OF THE DESIGN OF CLOTHING; DESIGN OF CUSTOM PAINTINGS; DESIGN OF INTERIOR DECOR; DESIGN SERVICES FOR PACKAGING; MEASUREMENT EVALUATIONS IN THE INTANGIBLE ASSETS FIELD; NEW PRODUCT DESIGN SERVICES; PROVISION OF SEARCH ENGINES FOR THE INTERNET; QUALITY CONTROL FOR OTHERS; RESEARCH AND DEVELOPMENT FOR NEW PRODUCTS FOR OTHERS (U.S. CLS. 100 AND 101).

FIRST USE 12-9-1999; IN COMMERCE 12-9-2002.
KIMBERLY PERRY, EXAMINING ATTORNEY

CLASS 42—(Continued).

SN 85-175,506. BIG LORETTA, LLC, INDIANAPOLIS, IN. FILED 11-12-2010.



NO CLAIM IS MADE TO THE EXCLUSIVE RIGHT TO USE "LLC.", APART FROM THE MARK AS SHOWN.

THE MARK CONSISTS OF THE DESIGN OF A WOMAN'S HEAD WITH A BOUFFANT HAIR STYLE AND SHOWING ONLY LIPS. UNDER THE DESIGN ARE THE STYLIZED WORDINGS "BIG LORETTA! LLC." AND "ITS ALWAYS FUN WITH BIG LORETTA..."

FOR COMPUTER SOFTWARE DEVELOPMENT IN THE FIELD OF LARGE USER DATABASES TO MARKET OTHER GOODS AND SERVICES TO THE DATABASE (U.S. CLS. 100 AND 101).

DAWN HAN, EXAMINING ATTORNEY

SN 85-177,495. REALOGIX, LLC, WOODBRIDGE, NJ. FILED 11-16-2010.

Visual Lease

THE MARK CONSISTS OF STANDARD CHARACTERS WITHOUT CLAIM TO ANY PARTICULAR FONT, STYLE, SIZE, OR COLOR.

NO CLAIM IS MADE TO THE EXCLUSIVE RIGHT TO USE "LEASE", APART FROM THE MARK AS SHOWN.

FOR PROVIDING ON-LINE NON-DOWNLOADABLE SOFTWARE FOR DATABASE DEVELOPMENT SERVICES FOR CREATING, ADMINISTERING, ABSTRACTING, AND MANAGING LEASES, RELATED DATA, AND BUSINESS CONTRACTS AND FOR THE PURPOSES OF STREAMLINING AND AUTOMATING THE CONTRACT MANAGEMENT PROCESS, NAMELY, FOR AUTOMATED BENCHMARKING, FOR TRACKING CRITICAL DATES, SCHEDULING COSTS AND ON-GOING TERMS FOR CONTRACT MANAGEMENT, FOR ABSTRACTING CRITICAL TERMS AND DATES FROM CONTRACTS, FOR DOCUMENT AND WORKFLOW MANAGEMENT, FOR PRESENTING REPORTS AND SUMMARIES OF CONTRACT INFORMATION IN SIMPLIFIED FORMATS, FOR PROVIDING ACCESS TO INFORMATION AND ANALYSIS ON BUSINESS TOPICS, NAMELY, REAL ESTATE, EQUIPMENT LEASING, WARRANTIES, FINANCE, TAX AND ACCOUNTING, FOR EXPORTING INFORMATION TO ACCOUNTING AND FINANCIAL SYSTEMS, AND TO ENABLE ERP INTEGRATION (U.S. CLS. 100 AND 101).

FIRST USE 7-0-1995; IN COMMERCE 10-0-1996.
MARK RADEMACHER, EXAMINING ATTORNEY

CLASS 42—(Continued).

SN 85-180,764. GLOBOFORCE LIMITED, DUBLIN, IRELAND, FILED 11-19-2010.

SOCIAL RECOGNITION

THE MARK CONSISTS OF STANDARD CHARACTERS WITHOUT CLAIM TO ANY PARTICULAR FONT, STYLE, SIZE, OR COLOR.

FOR SOFTWARE AS A SERVICE FEATURING SOFTWARE THAT PROVIDES NEWS FEEDS AND ONLINE NETWORKING IN THE FIELD OF ONLINE REWARDS PROGRAMS (U.S. CLS. 100 AND 101).

FIRST USE 4-7-2010; IN COMMERCE 5-15-2010.
JESSICA A. POWERS, EXAMINING ATTORNEY

SN 85-194,029. INTELLIGENT SOFTWARE SOLUTIONS, INC., COLORADO SPRINGS, CO. FILED 12-9-2010.

WebTAS

THE MARK CONSISTS OF STANDARD CHARACTERS WITHOUT CLAIM TO ANY PARTICULAR FONT, STYLE, SIZE, OR COLOR.

FOR SOFTWARE AS A SERVICE (SAAS) SERVICES FEATURING SOFTWARE FOR VISUALIZATION, INTEGRATION AND ANALYSIS OF DISPARATE DATA IN A SERVICE ORIENTED ARCHITECTURE (SOA) COMPLIANT PLATFORM (U.S. CLS. 100 AND 101).

SOPHIA S. KIM, EXAMINING ATTORNEY

SN 85-202,454. MEDTECH HOLDINGS, INC., SOUTH PLAINFIELD, NJ. FILED 12-21-2010.

VENTION MEDICAL

THE MARK CONSISTS OF STANDARD CHARACTERS WITHOUT CLAIM TO ANY PARTICULAR FONT, STYLE, SIZE, OR COLOR.

NO CLAIM IS MADE TO THE EXCLUSIVE RIGHT TO USE "MEDICAL", APART FROM THE MARK AS SHOWN.

FOR PRODUCT DESIGN AND DEVELOPMENT IN THE FIELD OF MEDICAL DEVICES; PRODUCT DEVELOPMENT AND ENGINEERING SERVICES FOR OTHERS; DESIGN AND TESTING FOR NEW PRODUCT DEVELOPMENT; DESIGN AND TESTING OF NEW PRODUCTS FOR OTHERS (U.S. CLS. 100 AND 101).

SKYE YOUNG, EXAMINING ATTORNEY

CLASS 42—(Continued).

SN 85-207,012. ZOOKBINDERS INC., DEERFIELD, IL. FILED 12-29-2010.

zookie pro

THE MARK CONSISTS OF STANDARD CHARACTERS WITHOUT CLAIM TO ANY PARTICULAR FONT, STYLE, SIZE, OR COLOR.

FOR DESIGN OF FINISHED PHOTOGRAPHIC ALBUMS FOR OTHERS (U.S. CLS. 100 AND 101).

C. DIONNE CLYBURN, EXAMINING ATTORNEY

SN 85-209,754. EDGEWAVE, INC., SAN DIEGO, CA. FILED 1-4-2011.

EDGEWAVE

THE MARK CONSISTS OF STANDARD CHARACTERS WITHOUT CLAIM TO ANY PARTICULAR FONT, STYLE, SIZE, OR COLOR.

FOR WEB, HARDWARE, NETWORK, COMPUTER, E-MAIL AND INTERNET SECURITY SERVICES, NAMELY, RESTRICTING ACCESS TO AND BY COMPUTER NETWORKS TO AND OF UNDESIRE WEB SITES, DESIGN AND DEVELOPMENT OF E-MAIL MESSAGING SECURITY AND ELECTRONIC DATA SECURITY SYSTEMS (U.S. CLS. 100 AND 101).

FIRST USE 1-12-2011; IN COMMERCE 1-12-2011.
DARRYL SPRUILL, EXAMINING ATTORNEY

SN 85-223,459. CHARDON LABORATORIES INC., REYNOLDSBURG, OH. FILED 1-21-2011.

REMOTECAST

THE MARK CONSISTS OF STANDARD CHARACTERS WITHOUT CLAIM TO ANY PARTICULAR FONT, STYLE, SIZE, OR COLOR.

FOR PROVIDING A WEB-BASED ONLINE PORTAL FOR CUSTOMERS TO REMOTELY MONITOR AND VIEW COOLING TOWER AND BOILER OPERATION DATA (U.S. CLS. 100 AND 101).

FIRST USE 0-0-1999; IN COMMERCE 0-0-1999.
SETH A. RAPPAPORT, EXAMINING ATTORNEY

CLASS 42—(Continued).

SN 85-236,422. YOBIZ, LLC, BALTIMORE, MD. FILED 2-8-2011.

BIZELO

THE MARK CONSISTS OF STANDARD CHARACTERS WITHOUT CLAIM TO ANY PARTICULAR FONT, STYLE, SIZE, OR COLOR.

FOR APPLICATION SERVICE PROVIDER (ASP) FEATURING SOFTWARE FOR USE IN BUSINESS INVENTORY MANAGEMENT, BILLING, ORDER PICKING, RETURNS MANAGEMENT, AUCTION MANAGEMENT, SHIPMENT TRACKING, PRINTING SHIPPING LABELS, TRACKING AND MANAGING BUSINESS SUPPLIES AND COSTS, CREATING PACKING LISTS, RECORD KEEPING, CUSTOMER RELATIONSHIP MANAGEMENT, EVENT AND APPOINTMENT SCHEDULING, TRANSACTION PROCESSING, MEMBERSHIP AND CUSTOMER MANAGEMENT FOR BUSINESSES, ORGANIZATIONS AND ASSOCIATIONS, FINANCIAL MANAGEMENT AND REPORTING, STUDENT MANAGEMENT FOR EDUCATIONAL INSTITUTIONS, FUND RAISING MANAGEMENT FOR ORGANIZATIONS AND ASSOCIATIONS, CROP MANAGEMENT AND LIVESTOCK MANAGEMENT FOR AGRICULTURAL BUSINESSES, FLEET MANAGEMENT, FACILITIES MANAGEMENT, LABOR TRACKING AND PAYROLL, TOUR, SPORTS LEAGUE, AND EVENT MANAGEMENT, PROJECT MANAGEMENT, REAL PROPERTY MANAGEMENT, MATERIALS MANAGEMENT FOR LIBRARIES, SERVICE MANAGEMENT FOR AUTOMOBILE REPAIR BUSINESSES, ADVERTISING MANAGEMENT, AND ASSET MANAGEMENT; PROVIDING TEMPORARY USE OF A WEB-BASED SOFTWARE APPLICATION FOR USE IN BUSINESS INVENTORY MANAGEMENT, BILLING, ORDER PICKING, RETURNS MANAGEMENT, AUCTION MANAGEMENT, SHIPMENT TRACKING, PRINTING SHIPPING LABELS, TRACKING AND MANAGING BUSINESS SUPPLIES AND COSTS, CREATING PACKING LISTS, RECORD KEEPING, CUSTOMER RELATIONSHIP MANAGEMENT, EVENT AND APPOINTMENT SCHEDULING, TRANSACTION PROCESSING, MEMBERSHIP AND CUSTOMER MANAGEMENT FOR BUSINESSES, ORGANIZATIONS AND ASSOCIATIONS, FINANCIAL MANAGEMENT AND REPORTING, STUDENT MANAGEMENT FOR EDUCATIONAL INSTITUTIONS, FUND RAISING MANAGEMENT FOR ORGANIZATIONS AND ASSOCIATIONS, CROP MANAGEMENT AND LIVESTOCK MANAGEMENT FOR AGRICULTURAL BUSINESSES, FLEET MANAGEMENT, FACILITIES MANAGEMENT, LABOR TRACKING AND PAYROLL, TOUR, SPORTS LEAGUE, AND EVENT MANAGEMENT, PROJECT MANAGEMENT, REAL PROPERTY MANAGEMENT, MATERIALS MANAGEMENT FOR LIBRARIES, SERVICE MANAGEMENT FOR AUTOMOBILE REPAIR BUSINESSES, ADVERTISING MANAGEMENT, AND ASSET MANAGEMENT; SOFTWARE AS A SERVICE (SAAS) SERVICES FEATURING SOFTWARE FOR USE IN BUSINESS INVENTORY MANAGEMENT, BILLING, ORDER PICKING, RETURNS MANAGEMENT, AUCTION MANAGEMENT, SHIPMENT TRACKING, PRINTING SHIPPING LABELS, TRACKING AND MANAGING BUSINESS SUPPLIES AND COSTS, CREATING PACKING LISTS, RECORD KEEPING, CUSTOMER RELATIONSHIP MANAGEMENT, EVENT AND APPOINTMENT SCHEDULING, TRANSACTION PROCESSING, MEMBERSHIP AND CUSTOMER MANAGEMENT FOR BUSINESSES, ORGANIZATIONS AND ASSOCIATIONS, FINANCIAL MANAGEMENT AND REPORTING, STUDENT MANAGEMENT FOR EDUCATIONAL INSTITUTIONS,

CLASS 42—(Continued).

FUND RAISING MANAGEMENT FOR ORGANIZATIONS AND ASSOCIATIONS, CROP MANAGEMENT AND LIVESTOCK MANAGEMENT FOR AGRICULTURAL BUSINESSES, FLEET MANAGEMENT, FACILITIES MANAGEMENT, LABOR TRACKING AND PAYROLL, TOUR, SPORTS LEAGUE, AND EVENT MANAGEMENT, PROJECT MANAGEMENT, REAL PROPERTY MANAGEMENT, MATERIALS MANAGEMENT FOR LIBRARIES, SERVICE MANAGEMENT FOR AUTOMOBILE REPAIR BUSINESSES, ADVERTISING MANAGEMENT, AND ASSET MANAGEMENT (U.S. CLS. 100 AND 101).

FIRST USE 12-0-2010; IN COMMERCE 12-0-2010.
MICHAEL ENGEL, EXAMINING ATTORNEY

SN 85-243,410. LINDSAY CORPORATION, OMAHA, NE. FILED 2-16-2011.



NO CLAIM IS MADE TO THE EXCLUSIVE RIGHT TO USE "RAILROAD PRODUCTS", APART FROM THE MARK AS SHOWN.

THE MARK CONSISTS OF THE WORDS "RAILROAD PRODUCTS" TO THE RIGHT OF A RAILROAD TRAFFIC SIGNAL.

FOR CUSTOM DESIGN AND ENGINEERING OF RAILROAD STRUCTURES, SIGNALS AND PARTS THEREFOR (U.S. CLS. 100 AND 101).

FIRST USE 7-0-2010; IN COMMERCE 7-0-2010.
CHRISTINA SOBRAL, EXAMINING ATTORNEY

SN 85-243,718. DEFENSE ADVANCED RESEARCH PROJECTS AGENCY, ARLINGTON, VA. FILED 2-16-2011.

100 YEAR STARSHIP

THE MARK CONSISTS OF STANDARD CHARACTERS WITHOUT CLAIM TO ANY PARTICULAR FONT, STYLE, SIZE, OR COLOR.

NO CLAIM IS MADE TO THE EXCLUSIVE RIGHT TO USE "STARSHIP", APART FROM THE MARK AS SHOWN.

FOR SCIENTIFIC AND TECHNOLOGICAL SERVICES, NAMELY, RESEARCH AND DEVELOPMENT, AND PROVIDING WEBSITES FEATURING TECHNOLOGY INFORMATION, ALL IN THE FIELD OF SPACE FLIGHT (U.S. CLS. 100 AND 101).

ANDREW LEASER, EXAMINING ATTORNEY

CLASS 42—(Continued).

SN 85-244,174. DEFENSE ADVANCED RESEARCH PROJECTS AGENCY, ARLINGTON, VA. FILED 2-16-2011.

100YSS

THE MARK CONSISTS OF STANDARD CHARACTERS WITHOUT CLAIM TO ANY PARTICULAR FONT, STYLE, SIZE, OR COLOR.

FOR SCIENTIFIC AND TECHNOLOGICAL SERVICES, NAMELY, RESEARCH AND DEVELOPMENT, AND PROVIDING WEBSITES FEATURING TECHNOLOGY INFORMATION, ALL IN THE FIELD OF SPACE FLIGHT (U.S. CLS. 100 AND 101).

ANDREW LEASER, EXAMINING ATTORNEY

SN 85-254,120. CHEEZBURGER, INC., SEATTLE, WA. FILED 3-1-2011.

Know Your Meme

THE MARK CONSISTS OF STANDARD CHARACTERS WITHOUT CLAIM TO ANY PARTICULAR FONT, STYLE, SIZE, OR COLOR.

NO CLAIM IS MADE TO THE EXCLUSIVE RIGHT TO USE "MEME", APART FROM THE MARK AS SHOWN.

FOR PROVIDING A WEBSITE THAT GIVES USERS THE ABILITY TO REVIEW VARIOUS PRINT, PHOTOGRAPHIC, GRAPHIC IMAGE, AND AUDIO AND VIDEO CONTENT AND UTILIZE A CUSTOM TEMPLATE TO PROVIDE INPUT, LIKES, DISLIKES, EDITS, CHANGES, MODIFICATIONS, OPINIONS, SUGGESTIONS, AND COMMENTS AND ENGAGE IN SOCIAL, BUSINESS AND COMMUNITY NETWORKING (U.S. CLS. 100 AND 101).

FIRST USE 9-4-2007; IN COMMERCE 9-4-2007.
INGRID C. EULIN, EXAMINING ATTORNEY

SN 85-255,821. TRUECONTEXT CORPORATION, OTTAWA, ONTARIO, CANADA, FILED 3-2-2011.

PRONTOFORMS

THE MARK CONSISTS OF STANDARD CHARACTERS WITHOUT CLAIM TO ANY PARTICULAR FONT, STYLE, SIZE, OR COLOR.

FOR PROVIDING TEMPORARY USE OF NON-DOWNLOADABLE COMPUTER SOFTWARE APPLICATIONS FOR MOBILE PHONES AND PORTABLE DEVICES ALLOWING A USER TO CREATE AND USE CUSTOMIZED AND GENERIC FORMS; COMPUTER SOFTWARE DEVELOPMENT IN THE FIELD OF MOBILE APPLICATIONS (U.S. CLS. 100 AND 101).

FIRST USE 9-30-2009; IN COMMERCE 9-30-2009.
LINDA MICKLEBURGH, EXAMINING ATTORNEY

CLASS 42—(Continued).

SN 85-258,749. HEATH TECNA INC., BELLINGHAM, WA. FILED 3-4-2011.

HEATHTECNA

THE MARK CONSISTS OF STANDARD CHARACTERS WITHOUT CLAIM TO ANY PARTICULAR FONT, STYLE, SIZE, OR COLOR.

FOR PRODUCT DESIGN, DEVELOPMENT, AND ENGINEERING SERVICES IN THE FIELD OF PASSENGER AIRCRAFT INTERIORS; TESTING AND EVALUATION OF PASSENGER AIRCRAFT INTERIORS FOR COMPLIANCE WITH FFA REGULATIONS (U.S. CLS. 100 AND 101).

FIRST USE 12-31-1958; IN COMMERCE 12-31-1958.
SANDRA BUJA, EXAMINING ATTORNEY

SN 85-260,208. KNO, INC., SANTA CLARA, CA. FILED 3-7-2011.

WORDS TO FRIENDS

THE MARK CONSISTS OF STANDARD CHARACTERS WITHOUT CLAIM TO ANY PARTICULAR FONT, STYLE, SIZE, OR COLOR.

FOR PROVIDING TEMPORARY USE OF ON-LINE NON-DOWNLOADABLE SOFTWARE FOR DELIVERY, DISPLAY, STORAGE AND MANIPULATION OF DATA, TEXT, IMAGES, AUDIO, AND VIDEO; APPLICATION SERVICE PROVIDER (ASP) FEATURING SOFTWARE FOR DELIVERY, DISPLAY, STORAGE AND MANIPULATION OF DATA, TEXT, IMAGES, AUDIO, AND VIDEO (U.S. CLS. 100 AND 101).

KIMBERLY PERRY, EXAMINING ATTORNEY

SN 85-260,239. KNO, INC., SANTA CLARA, CA. FILED 3-7-2011.

WTF

THE MARK CONSISTS OF STANDARD CHARACTERS WITHOUT CLAIM TO ANY PARTICULAR FONT, STYLE, SIZE, OR COLOR.

FOR PROVIDING TEMPORARY USE OF ON-LINE NON-DOWNLOADABLE SOFTWARE FOR DELIVERY, DISPLAY, STORAGE AND MANIPULATION OF DATA, TEXT, IMAGES, AUDIO, AND VIDEO; APPLICATION SERVICE PROVIDER (ASP) FEATURING SOFTWARE FOR DELIVERY, DISPLAY, STORAGE AND MANIPULATION OF DATA, TEXT, IMAGES, AUDIO, AND VIDEO (U.S. CLS. 100 AND 101).

KIMBERLY PERRY, EXAMINING ATTORNEY

CLASS 42—(Continued).

SN 85-261,861. SYSTIME COMPUTER CORPORATION, SAN FRANCISCO, CA. FILED 3-9-2011.

SYSTIME

THE MARK CONSISTS OF STANDARD CHARACTERS WITHOUT CLAIM TO ANY PARTICULAR FONT, STYLE, SIZE, OR COLOR.

FOR DESIGN, DEVELOPMENT AND IMPLEMENTATION OF COMPUTER SOFTWARE AND HARDWARE; AND TECHNICAL SUPPORT SERVICES, NAMELY, TROUBLESHOOTING OF COMPUTER HARDWARE AND SOFTWARE PROBLEMS (U.S. CLS. 100 AND 101).

FIRST USE 4-1-2000; IN COMMERCE 4-1-2000.
DAVID HOFFMAN, EXAMINING ATTORNEY

SN 85-262,380. CINECANDY, INC., SAN RAFAEL, CA. FILED 3-9-2011.

Cinecandy

THE MARK CONSISTS OF STANDARD CHARACTERS WITHOUT CLAIM TO ANY PARTICULAR FONT, STYLE, SIZE, OR COLOR.

FOR PROVIDING A WEBSITE FEATURING TECHNOLOGY THAT ENABLES USERS TO CREATE SOCIAL VIDEO (U.S. CLS. 100 AND 101).

WENDY JUN, EXAMINING ATTORNEY

SN 85-262,666. FOX WEATHER, LLC, FORTUNA, CA. FILED 3-9-2011.

MtnRT

THE MARK CONSISTS OF STANDARD CHARACTERS WITHOUT CLAIM TO ANY PARTICULAR FONT, STYLE, SIZE, OR COLOR.

FOR WEATHER INFORMATION (U.S. CLS. 100 AND 101).

FIRST USE 11-5-2005; IN COMMERCE 11-5-2005.
COURTNEY ALVAREZ, EXAMINING ATTORNEY

CLASS 42—(Continued).

SN 85-263,847. SOLAR ROYAL, LLC, WEST LAKE HILLS, TX. FILED 3-10-2011.



NO CLAIM IS MADE TO THE EXCLUSIVE RIGHT TO USE "SOLAR", APART FROM THE MARK AS SHOWN.

THE MARK CONSISTS OF A SOLAR/SUN SHAPED SYMBOL, WITH THE CENTRAL PORTION APPEARING AS BLADES ON A FAN, OVER THE WORDS "SOLAR" AND "ROYAL".

FOR DESIGN OF SOLAR AND GREEN-TECHNOLOGY VENTILATION PRODUCTS AND ACCESSORIES FOR COMMERCIAL AND RESIDENTIAL USE (U.S. CLS. 100 AND 101).

FIRST USE 12-8-2010; IN COMMERCE 12-8-2010.
WILLIAM BRECKENFELD, EXAMINING ATTORNEY

SN 85-264,321. BLUEPOINT SECURITY, INC., LOGANVILLE, GA. FILED 3-11-2011.



NO CLAIM IS MADE TO THE EXCLUSIVE RIGHT TO USE "SECURITY", APART FROM THE MARK AS SHOWN.

THE COLOR(S) GREEN, BLUE, BLACK AND GRAY IS/ARE CLAIMED AS A FEATURE OF THE MARK.

THE MARK CONSISTS OF THE WORDING "BLUEPOINT SECURITY" IN BLACK LOCATED NEXT TO A CIRCULAR IMAGE SUGGESTIVE OF A WORLD GLOBE WITH A GREEN AND BLUE IMAGE SUGGESTIVE OF A CIRCUIT BOARD INSTEAD OF THE CONTINENTS. THE GLOBE IS BEING WRAPPED BY A SECURITY SHIELD REPRESENTED BY TWO GRAY ARROWS COMING TOGETHER FROM THE LEFT AND RIGHT SIDES OF THE GLOBE.

FOR COMPUTER SERVICES, NAMELY, ON-LINE SCANNING, DETECTING, QUARANTINING AND ELIMINATING VIRUSES, WORMS, TROJANS, SPYWARE, ADWARE, MALWARE AND UNAUTHORIZED DATA AND PROGRAMS ON COMPUTERS AND ELECTRONIC DEVICES (U.S. CLS. 100 AND 101).

FIRST USE 11-30-2009; IN COMMERCE 11-30-2009.
CAROLYN CATALDO, EXAMINING ATTORNEY

CLASS 42—(Continued).

SN 85-264,341. BLUEPOINT SECURITY, INC., LOGANVILLE, GA. FILED 3-11-2011.

REVOLUTIONIZING COMPUTER
SECURITY

THE MARK CONSISTS OF STANDARD CHARACTERS WITHOUT CLAIM TO ANY PARTICULAR FONT, STYLE, SIZE, OR COLOR.

NO CLAIM IS MADE TO THE EXCLUSIVE RIGHT TO USE "COMPUTER SECURITY", APART FROM THE MARK AS SHOWN.

FOR COMPUTER SERVICES, NAMELY, ON-LINE SCANNING, DETECTING, QUARANTINING AND ELIMINATING VIRUSES, WORMS, TROJANS, SPYWARE, ADWARE, MALWARE AND UNAUTHORIZED DATA AND PROGRAMS ON COMPUTERS AND ELECTRONIC DEVICES (U.S. CLS. 100 AND 101).

FIRST USE 11-30-2009; IN COMMERCE 11-30-2009.
CAROLYN CATALDO, EXAMINING ATTORNEY

CLASS 42—(Continued).

SN 85-267,117. GLASS, KEVIN, MARBLEHEAD, MA. FILED 3-15-2011.



THE COLOR(S) YELLOW, BLACK AND WHITE IS/ARE CLAIMED AS A FEATURE OF THE MARK.

THE MARK CONSISTS OF A YELLOW HAYSTACK WITH BLACK SHADING; A BLACK MAGNIFYING GLASS IS ON THE HAYSTACK REVEALING BLACK COMPUTER CODE CONSISTING OF THE NUMBERS "1" AND "0" ON A WHITE BACKGROUND; BELOW THE HAYSTACK IS THE WORD "HAYSTACKID" IN BLACK STYLIZED FONT.

FOR ELECTRONIC LEGAL DISCOVERY CONSULTING SERVICES (U.S. CLS. 100 AND 101).
DAVID COLLIER, EXAMINING ATTORNEY

SN 85-266,442. NATHAN LESLIE DESIGNS, LLC, ARCHDALE, NC. FILED 3-14-2011.



THE MARK CONSISTS OF THE LITERAL ELEMENT "NLD" CENTERED INSIDE A CIRCLE.

FOR FURNITURE DESIGN SERVICES (U.S. CLS. 100 AND 101).

FIRST USE 1-1-2011; IN COMMERCE 1-1-2011.
JENNIFER DIXON, EXAMINING ATTORNEY

SN 85-267,160. WATERFALL FMS, INC., GREENBELT, MD. FILED 3-15-2011.

WATERFALL FMS

THE MARK CONSISTS OF STANDARD CHARACTERS WITHOUT CLAIM TO ANY PARTICULAR FONT, STYLE, SIZE, OR COLOR.

NO CLAIM IS MADE TO THE EXCLUSIVE RIGHT TO USE "FMS", APART FROM THE MARK AS SHOWN.

FOR SOFTWARE AS A SERVICE (SAAS) SERVICES, NAMELY, HOSTING SOFTWARE FOR USE BY OTHERS TO DEVELOP AND DEPLOY CUSTOMIZED E-COMMERCE WEBSITES, INTRANETS AND EXTRANETS, PUBLISH CONTENT ON SOCIAL NETWORKING WEBSITES, AND MANAGE CUSTOMER RELATIONSHIPS, SALES AND MARKETING ACTIVITIES (U.S. CLS. 100 AND 101).

FIRST USE 1-0-2011; IN COMMERCE 1-0-2011.
ALYSSA STEEL, EXAMINING ATTORNEY

CLASS 42—(Continued).

SN 85-267,646. WMC INSURANCE SERVICES, INC., DBA BETA BENEFITS INSURANCE SERVICES, SANTA ANA, CA. FILED 3-15-2011.



NO CLAIM IS MADE TO THE EXCLUSIVE RIGHT TO USE "BROKER" AND ".COM", APART FROM THE MARK AS SHOWN.

THE COLOR(S) BLACK, PURPLE, TAN AND YELLOW IS/ ARE CLAIMED AS A FEATURE OF THE MARK.

THE MARK CONSISTS OF THE STYLIZED WORDING "BROKERWOW.COM" AS WELL AS A DEPICTION PARTIALLY RISING SUN, A LINE UNDER THE TERM "WOW" AND A SEMI-CIRCLE ABOVE THE TERM "WOW". THE COLOR BLACK APPEARS IN THE WORDING "BROKER" AND ".COM" AS WELL AS OUTLINE OF THE RAYS OF THE PARTIALLY RISING SUN. THE COLOR PURPLE APPEARS IN THE WORDING "WOW". THE COLOR TAN APPEARS IN THE SHADOWS BEHIND THE SUN'S RAYS. THE COLOR YELLOW APPEARS IN THE DEPICTION OF THE SUN'S RAYS, THE LINE UNDER THE TERM "WOW" AS WELL AS THE SEMI-CIRCLE ABOVE THE TERM "WOW". THE COLOR WHITE IN THE DRAWING REPRESENTS BACKGROUND OR TRANSPARENT AREAS AND IS NOT PART OF THE MARK.

FOR PROVIDING AN ONLINE WEBSITE FEATURING NON-DOWNLOADABLE SOFTWARE FEATURING HIPPA COMPLIANT ENROLLMENT APPLICATION FORMS, A CUSTOMIZABLE EVENT CALENDAR FOR ATTENDING CERTIFICATION AND TRAINING MEETINGS, BROKER COMMISSION STATEMENTS, AND NON-DOWNLOADABLE SOFTWARE FOR PROVIDING A SECURE, WEB-BASED SERVICE ENABLING INDIVIDUALS TO REMOTELY CREATE AND MANAGE THEIR OWN ACCOUNTS SO THAT WHATEVER HIPPA COMPLAINT PRIVATE CONTENT THEY UPLOAD NOW CAN ENCRYPTED, THEN DELIVERED TO THEIR INTENDED RECIPIENTS, AT THE TIME AND IN THE MANNER REQUESTED (U.S. CLS. 100 AND 101).

MICHAEL TANNER, EXAMINING ATTORNEY

SN 85-268,754. CHOPRA, ANUBHAV, SAN DIEGO, CA. FILED 3-16-2011.

NINEPOINT6

THE MARK CONSISTS OF STANDARD CHARACTERS WITHOUT CLAIM TO ANY PARTICULAR FONT, STYLE, SIZE, OR COLOR.

FOR COMPUTER SERVICES, NAMELY, DESIGN AND DEVELOPMENT OF WEB SITES, MOBILE WEB SITES, AND MOBILE ADVERTISEMENTS AND CREATIVES FOR OTHERS; COMPUTER GRAPHICS DESIGN SERVICES; DESIGN OF HOME PAGES, COMPUTER SOFTWARE AND WEB SITES (U.S. CLS. 100 AND 101).

JAY FLOWERS, EXAMINING ATTORNEY

CLASS 42—(Continued).

SN 85-269,603. LIGHT SPEED SOLUTIONS, LLC., FARMINGDALE, NY. FILED 3-17-2011.

Light Speed Solutions

THE MARK CONSISTS OF STANDARD CHARACTERS WITHOUT CLAIM TO ANY PARTICULAR FONT, STYLE, SIZE, OR COLOR.

NO CLAIM IS MADE TO THE EXCLUSIVE RIGHT TO USE "SOLUTIONS", APART FROM THE MARK AS SHOWN.

FOR COMPUTER CONSULTATION; DESIGN AND DEVELOPMENT OF COMPUTER SOFTWARE; WEB SITE DESIGN (U.S. CLS. 100 AND 101).

FIRST USE 4-18-2005; IN COMMERCE 4-18-2005.

MARGERY A. TIERNEY, EXAMINING ATTORNEY

SN 85-270,045. KINDLL MARKETING, LLC, SANTA BARBARA, CA. FILED 3-17-2011.



THE MARK CONSISTS OF THE STYLIZED TEXT "QVIEW" ABOVE A CURVED LINE.

FOR SOFTWARE AS A SERVICE (SAAS) SERVICES FEATURING CUSTOM PLATFORM SOFTWARE FOR ALLOWING TEXT, IMAGES, VIDEO, LINKS, LOGO BRANDING, ADDRESS AND CONTACT INFORMATION UPLOAD AND HOSTING (U.S. CLS. 100 AND 101).

FIRST USE 3-0-2009; IN COMMERCE 3-0-2009.

NELSON SNYDER, EXAMINING ATTORNEY

SN 85-270,496. IBLOGIX, INC., WALTHAM, MA. FILED 3-18-2011.

FirstFuel

THE MARK CONSISTS OF STANDARD CHARACTERS WITHOUT CLAIM TO ANY PARTICULAR FONT, STYLE, SIZE, OR COLOR.

FOR PROVIDING TEMPORARY USE OF WEB-BASED SOFTWARE FOR REMOTELY BENCHMARKING AND REPORTING ENERGY PERFORMANCE OF BUILDINGS (U.S. CLS. 100 AND 101).

SEAN CROWLEY, EXAMINING ATTORNEY

CLASS 42—(Continued).

SN 85-271,705. CELERITOUS TECHNICAL SERVICES, CORP., LUBBOCK, TX. FILED 3-20-2011.



THE COLOR(S) BLACK, WHITE, YELLOW, PURPLE AND GRAY IS/ARE CLAIMED AS A FEATURE OF THE MARK.

THE MARK CONSISTS OF A CIRCULAR PURPLE FIELD CONTAINING A CONCENTRIC CIRCULAR PURPLE GRADIENT RANGING FROM DEEP PURPLE ON THE PERIPHERY TO WHITE MOVING TO THE CENTER WITH THE WHITE CENTER OFFSET TO THE UPPER LEFT QUADRANT OF THE FIELD TO MAKE THE CIRCULAR FIELD APPEAR SPHERICAL. OVERLAID ON THE SPHERICAL PURPLE GRADIENT IS A LIGHT PURPLE STREAK CURVING FROM THE LOWER LEFT TO UPPER RIGHT, TERMINATED BY A YELLOW CONCENTRIC CIRCULAR GRADIENT RANGING FROM YELLOW ON THE PERIPHERY TO WHITE IN THE CENTER. BEHIND THE CIRCULAR PURPLE GRADIENT IS A GRAY DROP SHADOW EXTENDING TO THE LOWER RIGHT. UNDERNEATH THE CIRCULAR PURPLE GRADIENT IS THE LITERAL ELEMENT TEXT "CELERITOUS" IN BLACK.

FOR ELECTRONIC AND ELECTRICAL SYSTEMS DESIGN SERVICES (U.S. CLS. 100 AND 101).

FIRST USE 12-3-1998; IN COMMERCE 12-3-1998.
LINDA POWELL, EXAMINING ATTORNEY

SN 85-272,909. VINOLEO SOLUTION & SERVICES CORPORATION, AKA VINOLEO, BROOKLYN, NY. FILED 3-21-2011.

Vinoleo

THE MARK CONSISTS OF STANDARD CHARACTERS WITHOUT CLAIM TO ANY PARTICULAR FONT, STYLE, SIZE, OR COLOR.

THE WORDING "VINOLEO" HAS NO MEANING IN A FOREIGN LANGUAGE.

FOR COMPUTER SYSTEMS INTEGRATION SERVICES (U.S. CLS. 100 AND 101).

FIRST USE 3-9-2003; IN COMMERCE 3-9-2003.
CHRISTINE MARTIN, EXAMINING ATTORNEY

CLASS 42—(Continued).

SN 85-273,193. ARRIOLA, NICOLAS, ORANGE, CA. FILED 3-22-2011.

Riol Resources

THE MARK CONSISTS OF STANDARD CHARACTERS WITHOUT CLAIM TO ANY PARTICULAR FONT, STYLE, SIZE, OR COLOR.

NO CLAIM IS MADE TO THE EXCLUSIVE RIGHT TO USE "RESOURCES", APART FROM THE MARK AS SHOWN.

FOR CONSULTING SERVICES IN THE FIELDS OF COMPUTER SOFTWARE, MOBILE PHONE APPLICATION SOFTWARE, AND HANDHELD ELECTRONIC DEVICE SOFTWARE TECHNOLOGY (U.S. CLS. 100 AND 101).

HEATHER THOMPSON, EXAMINING ATTORNEY

SN 85-273,375. THREE ROCKS GAMES LLC, WILMINGTON, DE. FILED 3-22-2011.



NO CLAIM IS MADE TO THE EXCLUSIVE RIGHT TO USE "GAMES", APART FROM THE MARK AS SHOWN.

THE MARK CONSISTS OF A STYLIZED DESIGN CONTAINING A MAIN GRAPHIC WHICH IS A CARTOON DEPICTION OF THE EARTH FROM SPACE, WITH THREE METEORS HEADING TOWARDS THE EARTH, EACH FOLLOWED BY A TRAIL OF DUST AND/OR GAS, AND SMALL CARTOON STARS IN THE BACKGROUND; THE WORDS "3 ROCKS GAMES" APPEAR IN STYLIZED TEXT AND ARE POSITIONED BELOW THE CARTOON DRAWING WITH THE NUMBER "3" TAKING UP TWO LINES OF TEXT ON THE LEFT, AND THE WORD "ROCKS" POSITIONED ABOVE THE WORD "GAMES" ON THE RIGHT.

FOR DESIGN AND DEVELOPMENT OF COMPUTER SOFTWARE (U.S. CLS. 100 AND 101).

FIRST USE 1-22-2011; IN COMMERCE 1-22-2011.
CHRISTINA SOBRAL, EXAMINING ATTORNEY

CLASS 42—(Continued).

SN 85-274,072. THIS IS B.S., INC., BLOOMINGTON, IL. FILED 3-23-2011.



NO CLAIM IS MADE TO THE EXCLUSIVE RIGHT TO USE "INC.", APART FROM THE MARK AS SHOWN.

THE MARK CONSISTS OF THE STYLIZED IMAGE OF A BULL, WITH THE WORDING "THIS IS B.S., INC."

FOR COMPUTER SERVICES, NAMELY, CREATING AN ON-LINE COMMUNITY FOR REGISTERED USERS TO PARTICIPATE IN DISCUSSIONS, GET FEEDBACK FROM THEIR PEERS, FORM VIRTUAL COMMUNITIES, AND ENGAGE IN SOCIAL NETWORKING FEATURING THE SHARING AND EXCHANGING OF MESSAGES, PICTURES AND VIDEOS WITH OTHER USERS ON A WIDE VARIETY OF TOPICS; HOSTING AN ON-LINE COMMUNITY WEB SITE FEATURING THE SHARING AND EXCHANGING OF MESSAGES, PICTURES AND VIDEOS WITH OTHER USERS ON A WIDE VARIETY OF TOPICS; PROVIDING A WEB SITE THAT GIVES COMPUTER USERS THE ABILITY TO UPLOAD, EXCHANGE AND SHARE PHOTOS, VIDEOS AND VIDEO LOGS; PROVIDING A WEBSITE FEATURING TECHNOLOGY THAT ENABLES USERS TO UPLOAD AND SHARE USER-GENERATED VIDEOS ON A WIDE VARIETY OF TOPICS AND SUBJECTS; PROVIDING A WEBSITE FEATURING TECHNOLOGY THAT ENABLES USERS TO SHARE AND EXCHANGE MESSAGES, PICTURES AND VIDEOS WITH OTHER USERS ON A WIDE VARIETY OF TOPICS (U.S. CLS. 100 AND 101).

FIRST USE 3-21-2011; IN COMMERCE 3-21-2011.
DEIRDRE ROBERTSON, EXAMINING ATTORNEY

SN 85-274,784. FOLLETT CORPORATION, RIVER GROVE, IL. FILED 3-23-2011.

COGNITE

THE MARK CONSISTS OF STANDARD CHARACTERS WITHOUT CLAIM TO ANY PARTICULAR FONT, STYLE, SIZE, OR COLOR.

FOR PROVIDING TEMPORARY USE OF ON-LINE, NON-DOWNLOADABLE SOFTWARE THAT ENABLES ACCESS TO AND USE OF DIGITAL EDUCATIONAL MATERIALS AND RESOURCES, NAMELY, LIBRARY MATERIALS, LESSON PLANS, CLASSROOM ASSIGNMENTS, USER-CREATED CONTENT, AND WEBSITES (U.S. CLS. 100 AND 101).

FIRST USE 6-1-2010; IN COMMERCE 6-1-2010.
KELLY CHOE, EXAMINING ATTORNEY

CLASS 42—(Continued).

SN 85-274,842. NASH CONTROLWARE, INC., MINNETONKA, MN. FILED 3-23-2011.

SAVIGENT SOFTWARE

THE MARK CONSISTS OF STANDARD CHARACTERS WITHOUT CLAIM TO ANY PARTICULAR FONT, STYLE, SIZE, OR COLOR.

NO CLAIM IS MADE TO THE EXCLUSIVE RIGHT TO USE "SOFTWARE", APART FROM THE MARK AS SHOWN.

FOR COMPUTER SOFTWARE DEVELOPMENT IN THE FIELD OF WORKFLOW AUTOMATION, SYSTEMS INTEGRATION, MANAGEMENT CONTROL, ENTERPRISE MANAGEMENT, PROCESS CONTROL, MANUFACTURING INTELLIGENCE; DESIGN, DEVELOPMENT AND IMPLEMENTATION OF SOFTWARE (U.S. CLS. 100 AND 101).

CHRISTOPHER BUONGIORNO, EXAMINING ATTORNEY

SN 85-274,907. JAY LOMBARD, NEW CITY, NY. FILED 3-23-2011.

Matrix Proteomics

THE MARK CONSISTS OF STANDARD CHARACTERS WITHOUT CLAIM TO ANY PARTICULAR FONT, STYLE, SIZE, OR COLOR.

NO CLAIM IS MADE TO THE EXCLUSIVE RIGHT TO USE "PROTEOMICS", APART FROM THE MARK AS SHOWN.

FOR DEVELOPMENT AND ESTABLISHMENT OF TESTING SPECIFICATIONS AND PROCEDURES IN THE FIELD OF PROTEINS; MEDICAL AND SCIENTIFIC RESEARCH IN THE FIELD OF PROTEINS; MEDICAL RESEARCH; PROVIDING MEDICAL AND SCIENTIFIC RESEARCH INFORMATION IN THE FIELD OF PHARMACEUTICALS AND CLINICAL TRIALS; PROVIDING MEDICAL AND SCIENTIFIC RESEARCH INFORMATION IN THE FIELDS OF PHARMACEUTICALS AND GENETICS (U.S. CLS. 100 AND 101).

CARYN GLASSER, EXAMINING ATTORNEY

CLASS 42—(Continued).

SN 85-274,926. LEANIN' TREE INC., BOULDER, CO. FILED 3-23-2011.

PERSONALIZE THE PERFECT
CARD AT WWW.LEANINTREE.COM

THE MARK CONSISTS OF STANDARD CHARACTERS WITHOUT CLAIM TO ANY PARTICULAR FONT, STYLE, SIZE, OR COLOR.

OWNER OF U.S. REG. NOS. 963,662, 1,998,062 AND 3,885,147.

FOR CUSTOM DESIGN OF GREETING CARDS BASED ON PERSONAL SELECTIONS MADE BY, AND PHOTOS, TEXT AND CONTENT PROVIDED BY, CUSTOMERS (U.S. CLS. 100 AND 101).

ROBIN MITTLER, EXAMINING ATTORNEY

SN 85-274,933. LEANIN' TREE INC., BOULDER, CO. FILED 3-23-2011.

CREATE THE PERFECT CARD AT
WWW.LEANINTREE.COM

THE MARK CONSISTS OF STANDARD CHARACTERS WITHOUT CLAIM TO ANY PARTICULAR FONT, STYLE, SIZE, OR COLOR.

OWNER OF U.S. REG. NOS. 963,662, 1,998,062 AND 3,885,147.

FOR CUSTOM DESIGN OF GREETING CARDS BASED ON PERSONAL SELECTIONS MADE BY, AND PHOTOS, TEXT AND CONTENT PROVIDED BY, CUSTOMERS (U.S. CLS. 100 AND 101).

ROBIN MITTLER, EXAMINING ATTORNEY

SN 85-275,288. IMPERIUM, LLC, WESTPORT, CT. FILED 3-24-2011.

VERITY+

THE MARK CONSISTS OF STANDARD CHARACTERS WITHOUT CLAIM TO ANY PARTICULAR FONT, STYLE, SIZE, OR COLOR.

OWNER OF U.S. REG. NO. 3,844,770.

FOR APPLICATION SERVICE PROVIDER FEATURING AN APPLICATION PROGRAMMING INTERFACE (API) SOFTWARE THAT ALLOWS USERS TO ACCESS A WEB SERVICE FOR PURPOSES OF VALIDATING NAMES AND ADDRESSES AND APPENDING OTHER DEMOGRAPHIC DATA OF INDIVIDUAL RESPONDENTS FOR MARKETERS, MARKET RESEARCH FIRMS AND OPERATORS OF E-COMMERCE WEBSITES (U.S. CLS. 100 AND 101).

FIRST USE 3-9-2011; IN COMMERCE 3-9-2011.

JEFFERY COWARD, EXAMINING ATTORNEY

CLASS 42—(Continued).

SN 85-275,297. IMPERIUM, LLC, WESTPORT, CT. FILED 3-24-2011.

M2

THE MARK CONSISTS OF STANDARD CHARACTERS WITHOUT CLAIM TO ANY PARTICULAR FONT, STYLE, SIZE, OR COLOR.

FOR APPLICATION SERVICE PROVIDER FEATURING AN APPLICATION PROGRAMMING INTERFACE (API) SOFTWARE THAT ALLOWS WEB-USERS TO DOWNLOAD AN APPLLET THAT ACCESSES FIELDS OF INFORMATION UNIQUE TO THE USER'S COMPUTER AND FURTHER VALIDATES THE IDENTITY OF THE USER'S COMPUTER FOR PURPOSES OF AVOIDING USER DUPLICATION AND FRAUD PREVENTION (U.S. CLS. 100 AND 101).

FIRST USE 3-9-2011; IN COMMERCE 3-9-2011.

JEFFERY COWARD, EXAMINING ATTORNEY

SN 85-275,824. REVENUE EDGE, SANTA CLARA, CA. FILED 3-24-2011.

Revenue Edge

THE MARK CONSISTS OF STANDARD CHARACTERS WITHOUT CLAIM TO ANY PARTICULAR FONT, STYLE, SIZE, OR COLOR.

NO CLAIM IS MADE TO THE EXCLUSIVE RIGHT TO USE "REVENUE", APART FROM THE MARK AS SHOWN.

FOR SOFTWARE AS A SERVICE (SAAS) SERVICES FEATURING SOFTWARE FOR ACCOUNTING, REVENUE ACCOUNTING, REVENUE RECOGNITION, REPORTING, AND BUSINESS INTELLIGENCE; AND CONSULTING SERVICES IN THE FIELD OF SOFTWARE AS A SERVICE (SAAS) (U.S. CLS. 100 AND 101).

FIRST USE 3-1-2009; IN COMMERCE 6-1-2010.

JOHN E. MICHOS, EXAMINING ATTORNEY

SN 85-276,210. INTOUCH SOLUTIONS, INC., OVERLAND PARK, KS. FILED 3-24-2011.

PHARMAWALL

THE MARK CONSISTS OF STANDARD CHARACTERS WITHOUT CLAIM TO ANY PARTICULAR FONT, STYLE, SIZE, OR COLOR.

FOR APPLICATION SERVICE PROVIDER FEATURING SOFTWARE FOR MANAGING, DEVELOPING, ANALYZING, MAINTAINING AND CONTROLLING CONTENT OF SOCIAL MEDIA SITES OF OTHERS IN THE PHARMACEUTICAL INDUSTRY (U.S. CLS. 100 AND 101).

FIRST USE 6-15-2011; IN COMMERCE 6-15-2011.

COLLEEN KEARNEY, EXAMINING ATTORNEY

CLASS 42—(Continued).

SN 85-276,362. SHINN, ROBERT, GRAYSLAKE, IL. AND ROBERT, DANA, GRAYSLAKE, IL. FILED 3-24-2011.

CLASS 42—(Continued).

SN 85-276,494. CHEN, CHIAYU J., BELLEVUE, WA. FILED 3-25-2011.

CLOUD SILVER LINING

NO CLAIM IS MADE TO THE EXCLUSIVE RIGHT TO USE "CLOUD", APART FROM THE MARK AS SHOWN. THE MARK CONSISTS OF THE TERM "CLOUD SILVER LINING," WITH THE LEFT STEM OF THE "V" IN A PEAK ABOVE THE TOP ARM OF ALL THE OTHER LETTERS, AND IN LINEAR FASHION, IT NARROWS TO A POINT. FOR CONSULTING IN THE FIELD OF IT PROJECT MANAGEMENT; IT CONSULTING SERVICES; TESTING, ANALYSIS, AND EVALUATION OF THE KNOWLEDGE, SKILLS AND ABILITIES OF OTHERS FOR THE PURPOSE OF CERTIFICATION AND RE-CERTIFICATION IN THE FIELD OF CLOUD COMPUTING (U.S. CLS. 100 AND 101). FIRST USE 12-1-2008; IN COMMERCE 12-1-2009. LEIGH CAROLINE CASE, EXAMINING ATTORNEY



SN 85-276,438. CHEN, CHIAYU J., BELLEVUE, WA. FILED 3-24-2011.

Two Mouths

THE MARK CONSISTS OF STANDARD CHARACTERS WITHOUT CLAIM TO ANY PARTICULAR FONT, STYLE, SIZE, OR COLOR. FOR COMPUTER SERVICES, NAMELY, CREATING ON-LINE COMMUNITIES FOR REGISTERED USERS TO SHARE IDEAS ESPECIALLY THOSE RELATING TO SUSTAINABLE DEVELOPMENT AND CLIMATE CHANGE, ADVERTISE, FIND JOB OPPORTUNITIES, PARTICIPATE IN DISCUSSIONS, ORGANIZE GROUPS AND EVENTS AND ENGAGE IN SOCIAL, BUSINESS AND COMMUNITY NETWORKING; PROVIDING A WEB SITE FEATURING TECHNOLOGY THAT ENABLES USERS TO UPLOAD, SHOW, VIEW AND SHARE IDEAS, INFORMATION, VIDEOS, PHOTOS, TEXT, GRAPHICS, LINKS AND DATA; PROVIDING A WEBSITE FEATURING TECHNOLOGY THAT ENABLES USERS TO SEARCH AND COMMUNICATE WITH OTHERS VIA ELECTRONIC COMMUNICATIONS NETWORKS TO NETWORK; PROVIDING A WEB SITE FEATURING TECHNOLOGY THAT ENABLES ONLINE USERS TO CREATE PERSONAL PROFILES FEATURING SOCIAL NETWORKING INFORMATION AND TO SHARE SUCH INFORMATION (U.S. CLS. 100 AND 101). GRETTA YAO, EXAMINING ATTORNEY

THE MARK CONSISTS OF A CHINESE CHARACTER THAT TRANSLITERATES TO "GUAN", "KUAN". THE NON-LATIN CHARACTERS IN THE MARK TRANSLITERATE TO "GUAN", "KUAN" AND THIS MEANS "GOVERNMENT OFFICIAL", "OFFICIAL", "PUBLIC SERVANT", "OFFICER", "ORGAN", "OFFICEHOLDER" IN ENGLISH. FOR COMPUTER SERVICES, NAMELY, CREATING ON-LINE COMMUNITIES FOR REGISTERED USERS TO SHARE IDEAS ESPECIALLY THOSE RELATING TO SUSTAINABLE DEVELOPMENT AND CLIMATE CHANGE, ADVERTISE, FIND JOB OPPORTUNITIES, PARTICIPATE IN DISCUSSIONS, ORGANIZE GROUPS AND EVENTS AND ENGAGE IN SOCIAL, BUSINESS AND COMMUNITY NETWORKING; PROVIDING A WEB SITE FEATURING TECHNOLOGY THAT ENABLES USERS TO UPLOAD, SHOW, VIEW AND SHARE IDEAS, INFORMATION, VIDEOS, PHOTOS, TEXT, GRAPHICS, LINKS AND DATA; PROVIDING A WEBSITE FEATURING TECHNOLOGY THAT ENABLES USERS TO SEARCH AND COMMUNICATE WITH OTHERS VIA ELECTRONIC COMMUNICATIONS NETWORKS TO NETWORK; PROVIDING A WEB SITE FEATURING TECHNOLOGY THAT ENABLES ONLINE USERS TO CREATE PERSONAL PROFILES FEATURING SOCIAL NETWORKING INFORMATION AND TO SHARE SUCH INFORMATION (U.S. CLS. 100 AND 101). GRETTA YAO, EXAMINING ATTORNEY

CLASS 42—(Continued).

SN 85-277,711. CHEN, CHIAYU J., BELLEVUE, WA. FILED 3-25-2011.



THE COLOR(S) GREEN AND WHITE IS/ARE CLAIMED AS A FEATURE OF THE MARK.

THE MARK CONSISTS OF A GREEN SHADED SQUARE FEATURING A CHINESE CHARACTER THAT TRANSLITERATES TO "GUAN", "KUAN" IN WHITE.

THE NON-LATIN CHARACTERS IN THE MARK TRANSLITERATE TO "GUAN", "KUAN" AND THIS MEANS "GOVERNMENT OFFICIAL", "OFFICIAL", "PUBLIC SERVANT", "OFFICER", "ORGAN", "OFFICEHOLDER" IN ENGLISH.

FOR COMPUTER SERVICES, NAMELY, CREATING ON-LINE COMMUNITIES FOR REGISTERED USERS TO SHARE IDEAS ESPECIALLY THOSE RELATING TO SUSTAINABLE DEVELOPMENT AND CLIMATE CHANGE, ADVERTISE, FIND JOB OPPORTUNITIES, PARTICIPATE IN DISCUSSIONS, ORGANIZE GROUPS AND EVENTS AND ENGAGE IN SOCIAL, BUSINESS AND COMMUNITY NETWORKING; PROVIDING A WEB SITE FEATURING TECHNOLOGY THAT ENABLES USERS TO UPLOAD, SHOW, VIEW AND SHARE IDEAS, INFORMATION, VIDEOS, PHOTOS, TEXT, GRAPHICS, LINKS AND DATA; PROVIDING A WEBSITE FEATURING TECHNOLOGY THAT ENABLES USERS TO SEARCH AND COMMUNICATE WITH OTHERS VIA ELECTRONIC COMMUNICATIONS NETWORKS TO NETWORK; PROVIDING A WEB SITE FEATURING TECHNOLOGY THAT ENABLES ONLINE USERS TO CREATE PERSONAL PROFILES FEATURING SOCIAL NETWORKING INFORMATION AND TO SHARE SUCH INFORMATION (U.S. CLS. 100 AND 101).

GRETTA YAO, EXAMINING ATTORNEY

SN 85-283,838. MORGAN, CAREY, SURPRISE, AZ. FILED 4-1-2011.

I AM GENX

THE MARK CONSISTS OF STANDARD CHARACTERS WITHOUT CLAIM TO ANY PARTICULAR FONT, STYLE, SIZE, OR COLOR.

FOR COMPUTER SERVICES, NAMELY, CREATING AN ON-LINE COMMUNITY FOR REGISTERED USERS TO PARTICIPATE IN DISCUSSIONS, GET FEEDBACK FROM THEIR PEERS, FORM VIRTUAL COMMUNITIES, AND ENGAGE IN SOCIAL NETWORKING SERVICES IN THE FIELD OF CURRENT EVENTS (U.S. CLS. 100 AND 101).

SCOTT BIBB, EXAMINING ATTORNEY

CLASS 42—(Continued).

SN 85-284,193. GO GO KIDDO INC., BELLEVUE, WA. FILED 4-1-2011.

VITAMIN FORTIFIED FUN

THE MARK CONSISTS OF STANDARD CHARACTERS WITHOUT CLAIM TO ANY PARTICULAR FONT, STYLE, SIZE, OR COLOR.

FOR COMPUTER SERVICES, NAMELY, INTERACTIVE HOSTING SERVICES WHICH ALLOW THE USER TO PUBLISH AND SHARE CONTENT AND IMAGES ON-LINE (U.S. CLS. 100 AND 101).

KATHERINE E. HALMEN, EXAMINING ATTORNEY

SN 85-284,200. GO GO KIDDO INC., BELLEVUE, WA. FILED 4-1-2011.



THE MARK CONSISTS OF THE WORDS "VITAMIN FORTIFIED FUN" WHICH APPEAR STACKED ON THREE LINES. THERE IS A SHADED OUTLINE AROUND THE WORDS.

FOR COMPUTER SERVICES, NAMELY, INTERACTIVE HOSTING SERVICES WHICH ALLOW THE USER TO PUBLISH AND SHARE CONTENT AND IMAGES ON-LINE (U.S. CLS. 100 AND 101).

KATHERINE E. HALMEN, EXAMINING ATTORNEY

CLASS 42—(Continued).

SN 85-284,646. GROUND LAB LLC, QUEENS, NY. FILED 4-2-2011.



THE MARK CONSISTS OF A SINGLE LINE CIRCLE BROKEN BY AN INTERIOR SYMBOL FOR THE "GND" ELECTRICAL SIGN, COMPOSED OF THREE PARALLEL RECTANGLES AND ONE TOP ATTACHED RECTANGLE.

FOR RESEARCH AND DEVELOPMENT OF TECHNOLOGY IN THE FIELD OF CONSERVATION, SOCIAL CHALLENGES, RENEWABLE ENERGY, HUMANITARIAN TECHNOLOGIES, EMERGENCY RELIEF, TRACKING AND LOGISTICS, INTERACTION DESIGN (U.S. CLS. 100 AND 101).

FIRST USE 12-1-2010; IN COMMERCE 12-1-2010.
REGINA DRUMMOND, EXAMINING ATTORNEY

SN 85-285,688. VICI METRONICS, INC., POULSBO, WA. FILED 4-4-2011.

METRONICS

THE MARK CONSISTS OF STANDARD CHARACTERS WITHOUT CLAIM TO ANY PARTICULAR FONT, STYLE, SIZE, OR COLOR.

FOR LABORATORY SERVICES, NAMELY, CALIBRATION OF MEASURING DEVICES FOR OTHERS; CALIBRATION, TESTING, AND CERTIFICATION SERVICES, NAMELY, CALIBRATION OF MEASURING DEVICES IN THE TERMS OF LEGAL METROLOGY, PERFORMANCE TESTING FOR THE CERTIFICATION OF PERMEATION DEVICES FOR OTHERS FOR THE PURPOSE OF CERTIFICATION (U.S. CLS. 100 AND 101).

BARBARA RUTLAND, EXAMINING ATTORNEY

CLASS 42—(Continued).

SN 85-287,141. ERLICH, LAWRENCE, VOORHEES, NJ. FILED 4-5-2011.

kiip

THE MARK CONSISTS OF STANDARD CHARACTERS WITHOUT CLAIM TO ANY PARTICULAR FONT, STYLE, SIZE, OR COLOR.

FOR COMPUTER NETWORK ADDRESS-MANAGEMENT SERVICES, NAMELY, PROVIDING SERVICES ENABLING ENTITIES TO REGISTER AND RESERVE DOMAIN NAMES AND OTHER COMPUTER NETWORK ADDRESSES ON THE INTERNET, AND TO ACCESS, ADD, MODIFY, OR DELETE INFORMATION RELATING TO SUCH DOMAIN NAMES AND ADDRESSES (U.S. CLS. 100 AND 101).

REGINA DRUMMOND, EXAMINING ATTORNEY

SN 85-288,442. RYAN WICKRE, DBA FIXED DESIGN, SAN FRANCISCO, CA. FILED 4-7-2011.

Fixed Design

THE MARK CONSISTS OF STANDARD CHARACTERS WITHOUT CLAIM TO ANY PARTICULAR FONT, STYLE, SIZE, OR COLOR.

NO CLAIM IS MADE TO THE EXCLUSIVE RIGHT TO USE "DESIGN", APART FROM THE MARK AS SHOWN. FOR FURNITURE DESIGN SERVICES; NEW PRODUCT DESIGN SERVICES (U.S. CLS. 100 AND 101).

FIRST USE 9-27-2009; IN COMMERCE 5-15-2010.
AMY KERTGATE, EXAMINING ATTORNEY

CLASS 42—(Continued).

SN 85-288,445. RENTAL SENTRY, LLC., HOLDEN BEACH, NC. FILED 4-7-2011.

Powered by VRMs

THE MARK CONSISTS OF STANDARD CHARACTERS WITHOUT CLAIM TO ANY PARTICULAR FONT, STYLE, SIZE, OR COLOR.

NO CLAIM IS MADE TO THE EXCLUSIVE RIGHT TO USE "VMRS", APART FROM THE MARK AS SHOWN.

FOR APPLICATION SERVICE PROVIDER (ASP) FEATURING SOFTWARE FOR USE FOR VACATION RENTAL MANAGERS; APPLICATION SERVICE PROVIDER FEATURING APPLICATION PROGRAMMING INTERFACE (API) SOFTWARE FOR ALLOWING DATA RETRIEVAL, UPLOAD, ACCESS AND MANAGEMENT; APPLICATION SERVICE PROVIDER FEATURING APPLICATION PROGRAMMING INTERFACE (API) SOFTWARE FOR USE IN BUILDING SOFTWARE APPLICATIONS; APPLICATION SERVICE PROVIDER FEATURING SOFTWARE FOR USE IN PROVIDING AN ON-LINE DATABASE IN THE FIELD OF TRANSACTION PROCESSING TO UPLOAD TRANSACTIONAL DATA, PROVIDE STATISTICAL ANALYSIS, AND PRODUCE NOTIFICATIONS AND REPORTS; APPLICATION SERVICE PROVIDER, NAMELY, HOSTING, MANAGING, DEVELOPING, ANALYZING, AND MAINTAINING APPLICATIONS, SOFTWARE, AND WEB SITES, OF OTHERS IN THE FIELDS OF ADVERTISING AND MARKETING; COMPUTER SERVICE, NAMELY, ACTING AS AN APPLICATION SERVICE PROVIDER IN THE FIELD OF INFORMATION MANAGEMENT TO HOST COMPUTER APPLICATION SOFTWARE FOR THE PURPOSE OF VACATION RENTAL MANAGEMENT; COMPUTER SERVICE, NAMELY, ACTING AS AN APPLICATION SERVICE PROVIDER IN THE FIELD OF KNOWLEDGE MANAGEMENT TO HOST COMPUTER APPLICATION SOFTWARE FOR CREATING SEARCHABLE DATABASES OF INFORMATION AND DATA; COMPUTER SERVICE, NAMELY, ACTING AS AN APPLICATION SERVICE PROVIDER IN THE FIELD OF KNOWLEDGE MANAGEMENT TO HOST COMPUTER APPLICATION SOFTWARE FOR SEARCHING AND RETRIEVING INFORMATION FROM DATABASES AND COMPUTER NETWORKS; COMPUTER SERVICE, NAMELY, ACTING AS AN APPLICATION SERVICE PROVIDER IN THE FIELD OF KNOWLEDGE MANAGEMENT TO HOST COMPUTER APPLICATION SOFTWARE FOR THE COLLECTION, EDITING, ORGANIZING, MODIFYING, BOOK MARKING, TRANSMISSION, STORAGE AND SHARING OF DATA AND INFORMATION (U.S. CLS. 100 AND 101).

FIRST USE 3-24-2011; IN COMMERCE 3-24-2011.

JOHN WILKE, EXAMINING ATTORNEY

CLASS 42—(Continued).

SN 85-288,448. RYAN WICKRE, DBA FIXED DESIGN, SAN FRANCISCO, CA. FILED 4-7-2011.



THE MARK CONSISTS OF A RECTANGLE THAT HAS BEEN BISECTED ON THE DIAGONAL TO FORM TWO QUADRILATERALS, WITH THE QUADRILATERAL ON THE LEFT APPEARING AS THE INVERSE IMAGE OF THE QUADRILATERAL ON THE RIGHT.

FOR FURNITURE DESIGN SERVICES; NEW PRODUCT DESIGN SERVICES (U.S. CLS. 100 AND 101).

FIRST USE 7-30-2010; IN COMMERCE 8-12-2010.

AMY KERTGATE, EXAMINING ATTORNEY

SN 85-288,926. RELIANT ENERGY RETAIL HOLDINGS, LLC, HOUSTON, TX. FILED 4-7-2011.

Reliant Bill Estimator

THE MARK CONSISTS OF STANDARD CHARACTERS WITHOUT CLAIM TO ANY PARTICULAR FONT, STYLE, SIZE, OR COLOR.

OWNER OF U.S. REG. NOS. 2,681,501, 3,528,114 AND OTHERS.

NO CLAIM IS MADE TO THE EXCLUSIVE RIGHT TO USE "BILL ESTIMATOR", APART FROM THE MARK AS SHOWN.

FOR PROVIDING ON-LINE, NON-DOWNLOADABLE, INTERNET-BASED SOFTWARE APPLICATION FOR ESTIMATING ELECTRICITY USAGE AND RELATED ELECTRICITY CHARGES (U.S. CLS. 100 AND 101).

KATHERINE CONNOLLY, EXAMINING ATTORNEY

CLASS 42—(Continued).

SN 85-288,981. TRAN, PAUL, SANTA ANA, CA. FILED 4-7-2011.



NO CLAIM IS MADE TO THE EXCLUSIVE RIGHT TO USE "INFORMATION", "TECHNOLOGY" OR "SOLUTIONS", APART FROM THE MARK AS SHOWN.

THE COLOR(S) BLACK, BLUE, YELLOW, BROWN, GREEN, GREY AND WHITE IS/ARE CLAIMED AS A FEATURE OF THE MARK.

THE MARK CONSISTS OF A CIRCLE WITH A BLACK OUTLINE AND BLUE INTERIOR. WITHIN THE CIRCLE ARE FIVE SMALLER CIRCLES. ALL ARE LINED IN BLACK. THE UPPER LEFT IS YELLOW AND CONTAINS THE WORD "INFORMATION" IN BLUE, THE UPPER RIGHT IS BROWN AND CONTAINS "TECHNOLOGY" IN BLUE, THE BOTTOM LEFT IS GREEN WITH "DISCUSSIONS" IN BLUE, AND THE RIGHT BOTTOM IS GREY WITH "SOLUTIONS" IN BLUE. IN THE MIDDLE OF THESE FOUR CIRCLES IS A SMALLER WHITE CIRCLE LINED IN BLACK CONTAINING "4" IN BLACK. BETWEEN EACH OF THE FOUR INTERIOR CIRCLES IS A WHITE ARROW LINED IN BLACK WITH "GOTOTRAN" IN BLACK.

FOR IT CONSULTING SERVICES; IT INTEGRATION SERVICES (U.S. CLS. 100 AND 101).

REBECCA POVARCHUK, EXAMINING ATTORNEY

SN 85-289,061. TIPSTER SOFTWARE, LLC, DAVIE, FL. FILED 4-7-2011.

SKINNIO

THE MARK CONSISTS OF STANDARD CHARACTERS WITHOUT CLAIM TO ANY PARTICULAR FONT, STYLE, SIZE, OR COLOR.

FOR COMPUTER SERVICES, NAMELY, CREATING AN ON-LINE COMMUNITY FOR REGISTERED USERS TO PARTICIPATE IN DISCUSSION, GET FEEDBACK FROM THEIR PEERS, FORM VIRTUAL COMMUNITIES, AND ENGAGE IN SOCIAL NETWORKING (U.S. CLS. 100 AND 101).

DAVID COLLIER, EXAMINING ATTORNEY

CLASS 42—(Continued).

SN 85-289,177. AVA LIVING INTERNATIONAL INC., DBA AVA LIVING, LONG BEACH, CA. FILED 4-7-2011.

Ava Living

THE MARK CONSISTS OF STANDARD CHARACTERS WITHOUT CLAIM TO ANY PARTICULAR FONT, STYLE, SIZE, OR COLOR.

FOR ARCHITECTURAL DESIGN; COLOR ANALYSIS FOR PURPOSES OF INTERIOR DESIGN; CONSULTATION IN THE FIELD OF ERGONOMICS, NAMELY, DESIGNING WORKPLACE FACILITIES AND EQUIPMENT TO OPTIMIZE EFFICIENCY AND SAFETY; CONSULTING SERVICES FOR THE DESIGN OF MASONRY WALLS AND STRUCTURES; CONSULTING SERVICES IN THE FIELD OF ARCHITECTURAL DESIGN; CONSULTING SERVICES IN THE FIELD OF THEME PARK ATTRACTION DESIGN; CREATING AND DESIGNING WEB PAGES FOR OTHERS; CREATING, DESIGNING AND MAINTAINING WEB SITES; DESIGN AND CREATING WEB SITES FOR OTHERS; DESIGN AND DEVELOPMENT AND CONSULTING SERVICES RELATED THERETO IN THE FIELD OF CUSTOM HOME THEATRE AUDIO AND VISUAL SYSTEMS; DESIGN AND DEVELOPMENT OF AUTOMATED CONTROLLER SYSTEMS, NAMELY, TEMPERATURE, HUMIDITY AND ELECTRICAL CONTROLLERS; DESIGN AND DEVELOPMENT OF AUTOMATED HOME CONTROLLER SYSTEMS, NAMELY, TEMPERATURE, HUMIDITY, AND ELECTRICAL CONTROLLERS; DESIGN AND MAINTENANCE OF WEB SITES FOR OTHERS; DESIGN AND STYLING OF MINIATURE ROOMS FOR DISPLAY PURPOSES; DESIGN OF HOME PAGES; DESIGN OF HOME PAGES AND WEB SITES; DESIGN OF HOME PAGES, COMPUTER SOFTWARE AND WEB SITES; DESIGN OF HOMEPAGES AND WEBSITES; DESIGN OF INTERIOR DECOR; DESIGN OF MASONRY WALLS AND STRUCTURES; DESIGN OF SPECIALTY INTERIOR AND EXTERIOR ENVIRONMENT SETTINGS; DESIGN, CREATION, HOSTING, MAINTENANCE OF WEBSITES FOR OTHERS; DESIGNING INTERNET SITES FOR OTHERS; DESIGNING WEB PAGES FOR OTHERS; DESIGNING WEBSITES FOR ADVERTISING PURPOSES; DESIGNING WEBSITES FOR OTHERS; DESIGNING, CREATING, MAINTAINING AND HOSTING ONLINE RETAIL AND ELECTRONIC COMMERCE WEBSITES FOR OTHERS; DESIGNING, CREATING, MAINTAINING, AND HOSTING INTERIOR DESIGN WEBSITES FOR OTHERS; DEVELOPMENT, DESIGN AND UPDATING OF HOME PAGES; DOOR DESIGN SERVICES; FURNITURE DESIGN SERVICES; HOME STAGING CONSULTATION, NAMELY, TEMPORARY INTERIOR AND EXTERIOR HOME DECORATION CONSULTATION FOR THE PURPOSE OF MAKING HOMES MORE APPEALING TO PROSPECTIVE BUYERS; HOMEPAGE AND WEBPAGE DESIGN; HOSPITAL DESIGN SERVICES; INTERIOR DECORATING; INTERIOR DECORATION CONSULTATION; INTERIOR DESIGN SERVICES; INTERIOR DESIGN SERVICES IN THE NATURE OF AROMA CONSULTING SERVICES IN THE SELECTION AND USE OF AROMAS FOR HOTELS, CASINOS, RESORTS, CONFERENCE FACILITIES, RETAIL STORES, SPORTS AND FITNESS CENTERS, SPAS, HEALTH CARE FACILITIES, RESIDENTIAL BUILDINGS AND PRIVATE RESIDENCES; INTERIOR DESIGN SERVICES INCLUDING SPACE PLANNING, FURNITURE SELECTION, MATERIAL AND SURFACE SELECTION; INTERIOR STYLING SERVICES; LANDSCAPE ARCHITECTURAL DESIGN; LANDSCAPE LIGHTING DESIGN; LIGHTING DESIGN AND TECHNOLOGY SPECIFICATION SERVICES PERTAINING TO PERMANENT OR TEMPORARY ARCHITECTURAL, THEATRICAL, ENTERTAINMENT, COMMERCIAL AND/OR RESIDENTIAL APPLICATIONS; PAINT MATCHING, NAMELY, COLOR ANALYSIS TO DETERMINE PROPER PAINT MIXTURE FOR MATCHING COLORS FOR INTERIOR DECORATING PURPOSES; PLANNING AND DESIGN OF HORSE-RIDING ARENAS; PLANNING AND DE-

CLASS 42—(Continued).

SIGNING AQUATICS FACILITIES; PLANNING AND LAYOUT DESIGN FOR THE INTERIOR SPACE OF RETAIL BUSINESS ESTABLISHMENTS; PLANNING AND LAYOUT DESIGN SERVICES FOR CLEANROOM ENVIRONMENTS; PROVIDING A WEBSITE FEATURING INFORMATION ABOUT GREEN ARCHITECTURE, INTERIOR DESIGN, SUSTAINABLE COMMUNITY PLANNING AND INFRASTRUCTURE DEVELOPMENT; PROVIDING A WEBSITE FEATURING INFORMATION IN THE FIELD OF INTERIOR DESIGN AND ARCHITECTURE FOR USE BY INTERIOR DESIGNERS AND ARCHITECTS; PROVIDING A WEBSITE FEATURING ON-LINE NON-DOWNLOADABLE SOFTWARE THAT ENABLES USERS TO PROVIDE INTERIOR DESIGN SERVICES; PROVIDING AN INTERNET WEBSITE PORTAL OFFERING INFORMATION IN THE FIELD OF COMPUTER AIDED DESIGN; PROVIDING DESIGN SERVICES FOR OTHERS IN THE FIELD OF THEME PARKS, MUSEUMS, AND MINIATURE GOLF COURSES; PROVIDING ENVIRONMENTALLY FRIENDLY AUTOMATION SOLUTIONS, NAMELY, SITE EVALUATIONS, CONTROL DESIGN ANALYSIS, AND INTEGRATED INSTALLATION SERVICES FOR MONITORING AND CONTROLLING RESPECTIVE INNOVATIVE DEVICES WITHIN A DESIGNATED AREA; PROVIDING GRAPHIC AND MULTIMEDIA DESIGN SERVICES FOR THE PURPOSE OF PROMOTING THE GOODS AND SERVICES OF OTHERS; PROVIDING GRAPHIC DESIGN SERVICES TO CREATE SPECIALTY INTERIOR ENVIRONMENT SETTINGS; RESIDENTIAL BUILDING DESIGN; ROOM DESIGN CONSISTING OF SELECTION OF ARTWORK, LIGHTING, AND FURNISHINGS FOR AN ENVIRONMENT DESIGNED TO HELP ACHIEVE MENTAL WELLNESS, INCLUDING STRESS MANAGEMENT AND RELAXATION, USING COMPUTER CONTROLLED ADVANCED SOUND WAVE TECHNOLOGY; SET DESIGN FOR THEATRICAL ENTERPRISES; SHOP INTERIOR DESIGN; STRUCTURAL ENGINEERING DESIGN SERVICES; SURVEY DESIGN AND RESEARCH; TEMPORARY INTERIOR AND EXTERIOR HOME DECORATION CONSULTATION, NAMELY, HOME STAGING CONSULTATION FOR THE PURPOSE OF MAKING HOMES MORE APPEALING TO PROSPECTIVE BUYERS; THEME PARK ATTRACTION DESIGN SERVICES; URBAN DESIGN PLANNING SERVICES; WEB SITE DESIGN (U.S. CLS. 100 AND 101).

FIRST USE 10-1-2005; IN COMMERCE 5-1-2007.
LINDA M. KING, EXAMINING ATTORNEY

SN 85-289,508. DOUBLE BOTTOM LINE PARTNERS, LLC, BOSTON, MA. FILED 4-7-2011.

HCRReview

THE MARK CONSISTS OF STANDARD CHARACTERS WITHOUT CLAIM TO ANY PARTICULAR FONT, STYLE, SIZE, OR COLOR.

FOR COMPUTER SERVICES, NAMELY, PROVIDING A WEB-BASED SYSTEM AND ONLINE PORTAL FEATURING ON-LINE NON-DOWNLOADABLE SOFTWARE THAT ENABLES USERS TO ACCESS TRAINING, EDUCATION, TESTING AND CERTIFICATION MATERIALS IN THE FIELD OF HEALTH CARE AND EMERGENCY MEDICAL SERVICES (U.S. CLS. 100 AND 101).

ALEXANDER L. POWERS, EXAMINING ATTORNEY

CLASS 42—(Continued).

SN 85-290,256. MEDICAL DIAGNOSTIC LABORATORIES, LLC, HAMILTON, NJ. FILED 4-8-2011.

IT'S ALL ABOUT THE SCIENCE

THE MARK CONSISTS OF STANDARD CHARACTERS WITHOUT CLAIM TO ANY PARTICULAR FONT, STYLE, SIZE, OR COLOR.

FOR RESEARCH AND DEVELOPMENT IN THE PHARMACEUTICAL AND BIOTECHNOLOGY FIELDS (U.S. CLS. 100 AND 101).

ELLEN BURNS, EXAMINING ATTORNEY

SN 85-291,031. INSPIRATION ENGINE, LLC, SANDY, UT. FILED 4-9-2011.

e.mote

THE MARK CONSISTS OF STANDARD CHARACTERS WITHOUT CLAIM TO ANY PARTICULAR FONT, STYLE, SIZE, OR COLOR.

FOR AN INTERNET BASED SOFTWARE AS A SERVICE SURVEY, ANALYTICS, AND REPORTING PLATFORM THAT ENABLES BUSINESSES TO SURVEY, MONITOR AND MEASURE PEOPLE'S EMOTIONAL ENGAGEMENT ACROSS THEIR BUSINESS VIA SMART PHONES, MOBILE DEVICES, AND WEB BROWSERS (U.S. CLS. 100 AND 101).

FIRST USE 9-3-2010; IN COMMERCE 9-21-2010.
JUSTINE D. PARKER, EXAMINING ATTORNEY

SN 85-291,185. THIRD BOXCAR, LLC, DBA THIRD BOXCAR, SEATTLE, WA. FILED 4-10-2011.

Third Boxcar

THE MARK CONSISTS OF STANDARD CHARACTERS WITHOUT CLAIM TO ANY PARTICULAR FONT, STYLE, SIZE, OR COLOR.

FOR COMMERCIAL ART DESIGN; DESIGN AND MAINTENANCE OF WEB SITES FOR OTHERS; INDUSTRIAL AND GRAPHIC ART DESIGN; PROVIDING GRAPHIC AND MULTIMEDIA DESIGN SERVICES FOR THE PURPOSE OF PROMOTING THE GOODS AND SERVICES OF OTHERS; WEBSITE DESIGN AND DEVELOPMENT FOR OTHERS (U.S. CLS. 100 AND 101).

FIRST USE 5-27-2009; IN COMMERCE 5-27-2009.
JOHN DWYER, EXAMINING ATTORNEY

CLASS 42—(Continued).

SN 85-291,371. CLICKBOX SOFTWARE INC., BRAMPTON, CANADA, FILED 4-11-2011.

ilumii

THE MARK CONSISTS OF STANDARD CHARACTERS WITHOUT CLAIM TO ANY PARTICULAR FONT, STYLE, SIZE, OR COLOR.

FOR HOSTING AN ON-LINE COMMUNITY WEB SITE FEATURING ONLINE TRAINING SYSTEMS AND LEARNING METHODOLOGIES FOR ONLINE USERS IN ACADEMICS (U.S. CLS. 100 AND 101).

FIRST USE 4-30-2009; IN COMMERCE 4-30-2009.
JASON LOTT, EXAMINING ATTORNEY

CLASS 42—(Continued).

SN 85-292,531. CHROME SYSTEMS, INC., PORTLAND, OR, FILED 4-12-2011.

TRADEDRIVER

THE MARK CONSISTS OF STANDARD CHARACTERS WITHOUT CLAIM TO ANY PARTICULAR FONT, STYLE, SIZE, OR COLOR.

FOR PROVIDING TEMPORARY USE OF NON-DOWNLOADABLE SOFTWARE FOR CUSTOMERS TO CALCULATE THE TRADE VALUE OF THEIR AUTOMOBILE VIA THE INTERNET (U.S. CLS. 100 AND 101).

LIEF MARTIN, EXAMINING ATTORNEY

SN 85-291,477. FAN APPZ, INC., SANTA MONICA, CA, FILED 4-11-2011.

FAN TABZ

THE MARK CONSISTS OF STANDARD CHARACTERS WITHOUT CLAIM TO ANY PARTICULAR FONT, STYLE, SIZE, OR COLOR.

OWNER OF U.S. REG. NO. 3,874,422.
FOR APPLICATION SERVICE PROVIDER, NAMELY, PROVIDING AND DEVELOPING INTERNET APPLICATIONS RELATED TO FASHION, PRODUCTS, MEDIA, TRENDS, RESTAURANTS, RETAILERS, POPULAR CULTURE AND INTERNET SITES; APPLICATION SERVICE PROVIDER, NAMELY, PROVIDING AND DEVELOPING INTERNET APPLICATIONS TO HELP CUSTOMIZE AND LAUNCH WEB PAGE CONTENT (U.S. CLS. 100 AND 101).

LAKEISHA LEWIS, EXAMINING ATTORNEY

SN 85-292,537. BUCK CONSULTANTS, LLC, NEW YORK, NY, FILED 4-12-2011.

Buck Benefits

THE MARK CONSISTS OF STANDARD CHARACTERS WITHOUT CLAIM TO ANY PARTICULAR FONT, STYLE, SIZE, OR COLOR.

OWNER OF U.S. REG. NOS. 2,542,117 AND 2,590,226.
NO CLAIM IS MADE TO THE EXCLUSIVE RIGHT TO USE "BENEFITS", APART FROM THE MARK AS SHOWN.
FOR DEVELOPING COMPUTER PROGRAMS FOR OTHERS, NAMELY, DEVELOPING COMPUTER PROGRAMS FOR STORING AND RETRIEVING USER DATA IN THE FIELD OF MEDICAL AND INSURANCE INFORMATION, HUMAN RESOURCES INFORMATION, AND CALENDARING AND APPOINTMENTS INFORMATION (U.S. CLS. 100 AND 101).

FIRST USE 7-30-2010; IN COMMERCE 7-30-2010.
DAWN HAN, EXAMINING ATTORNEY

SN 85-291,506. MINNEAMRITA THERAPEUTICS LLC, MO-LINE, IL, FILED 4-11-2011.

ENRICHING HEALTH, ENHANCING LIFE

THE MARK CONSISTS OF STANDARD CHARACTERS WITHOUT CLAIM TO ANY PARTICULAR FONT, STYLE, SIZE, OR COLOR.

FOR PHARMACEUTICAL RESEARCH AND DRUG DEVELOPMENT; MEDICAL AND SCIENTIFIC RESEARCH, NAMELY, CONDUCTING CLINICAL TRIALS; DEVELOPMENT OF PHARMACEUTICALS FOR THE TREATMENT OF CANCER (U.S. CLS. 100 AND 101).

MARY CRAWFORD, EXAMINING ATTORNEY

SN 85-292,694. BLEKKO, INC., REDWOOD CITY, CA, FILED 4-12-2011.

SuperPrivacy

THE MARK CONSISTS OF STANDARD CHARACTERS WITHOUT CLAIM TO ANY PARTICULAR FONT, STYLE, SIZE, OR COLOR.

FOR SEARCH ENGINE SERVICES, NAMELY, PROVIDING SEARCH ENGINES ON THE INTERNET; COMPUTER SERVICES, NAMELY, CREATING INDEXES OF INFORMATION, SITES AND OTHER RESOURCES AVAILABLE ON COMPUTER NETWORKS AND COMMUNICATIONS NETWORKS (U.S. CLS. 100 AND 101).

DAVID I, EXAMINING ATTORNEY

CLASS 42—(Continued).

SN 85-292,735. VOX DIGITAL MEDIA, INC., JOPLIN, MO. FILED 4-12-2011.

CLASS 42—(Continued).

SN 85-292,912. THOMPSON, ROBERT D., LAS VEGAS, NV. FILED 4-12-2011.

2BHEARD



THE MARK CONSISTS OF STANDARD CHARACTERS WITHOUT CLAIM TO ANY PARTICULAR FONT, STYLE, SIZE, OR COLOR.

FOR PROVIDING A WEB SITE FEATURING TECHNOLOGY THAT ENABLES USERS TO UPLOAD AND PUBLISH BOOKS, MAGAZINES, STORIES, ARTICLES, SHEET MUSIC, DIGITAL AUDIO, PHOTOGRAPHS AND VIDEOS, AND TO PURCHASE AND DOWNLOAD BOOKS, MAGAZINES, STORIES, ARTICLES, SHEET MUSIC, DIGITAL AUDIO, PHOTOGRAPHS AND VIDEOS (U.S. CLS. 100 AND 101).

FIRST USE 4-5-2011; IN COMMERCE 4-5-2011.
GIANCARLO CASTRO, EXAMINING ATTORNEY

THE COLOR(S) BLUE, PURPLE, RED AND YELLOW IS/ ARE CLAIMED AS A FEATURE OF THE MARK.

THE MARK CONSISTS OF A HORIZONTAL MEASURING COLOR BAR, CONSISTING OF THE COLORS BLUE, PURPLE AND RED WITH A SUPERIMPOSED YELLOW SLIDER, SIGNIFIED BY A YELLOW LINE.

FOR PROVIDING A WEBSITE FEATURING RESOURCES, NAMELY, NON-DOWNLOADABLE SOFTWARE FOR THE ASSESSMENT AND DIAGNOSING OF MENTAL DISORDERS AND CONDITIONS, INCLUDING DEPRESSION (U.S. CLS. 100 AND 101).

FIRST USE 6-0-2010; IN COMMERCE 6-0-2010.
JILL C. ALT, EXAMINING ATTORNEY

SN 85-292,865. THOMPSON, ROBERT D., LAS VEGAS, NV. FILED 4-12-2011.

SN 85-293,281. SPROXIL, INC., SOMERVILLE, MA. FILED 4-12-2011.

MEASURING THE UNMEASURABLE



THE MARK CONSISTS OF STANDARD CHARACTERS WITHOUT CLAIM TO ANY PARTICULAR FONT, STYLE, SIZE, OR COLOR.

FOR PROVIDING A WEBSITE FEATURING RESOURCES, NAMELY, NON-DOWNLOADABLE SOFTWARE FOR THE ASSESSMENT AND DIAGNOSING OF MENTAL DISORDERS AND CONDITIONS, INCLUDING DEPRESSION (U.S. CLS. 100 AND 101).

FIRST USE 6-0-2010; IN COMMERCE 6-0-2010.
JILL C. ALT, EXAMINING ATTORNEY

THE MARK CONSISTS OF A SHADED RECTANGULAR BOX WITH THE WORD "SPROXIL" APPEARING WITHIN AND A CIRCLE APPEARING AT THE RIGHT EDGE OF THE BOX.

FOR DESIGN AND IMPLEMENTATION OF SOFTWARE AND TECHNOLOGY SOLUTIONS FOR THE PURPOSE OF PRODUCT AND DOCUMENT AUTHENTICATION AND TRACKING, AND BRAND MONITORING AND PROTECTION, TO PROTECT AGAINST COUNTERFEITING, TAMPERING, AND DIVERSION, AND TO ENSURE THE INTEGRITY OF GENUINE PRODUCTS AND DOCUMENTS; PROVIDING TEMPORARY USE OF NON-DOWNLOADABLE COMPUTER SOFTWARE FOR TRACKING PACKAGES OVER COMPUTER NETWORKS, INTRANETS AND THE INTERNET (U.S. CLS. 100 AND 101).

HAI-LY LAM, EXAMINING ATTORNEY

CLASS 42—(Continued).

SN 85-293,362. SPROXIL, INC., SOMERVILLE, MA. FILED 4-12-2011.

SPROXIL

THE MARK CONSISTS OF STANDARD CHARACTERS WITHOUT CLAIM TO ANY PARTICULAR FONT, STYLE, SIZE, OR COLOR.

FOR DESIGN AND IMPLEMENTATION OF SOFTWARE AND TECHNOLOGY SOLUTIONS FOR THE PURPOSE OF PRODUCT AND DOCUMENT AUTHENTICATION AND TRACKING, AND BRAND MONITORING AND PROTECTION, TO PROTECT AGAINST COUNTERFEITING, TAMPERING, AND DIVERSION, AND TO ENSURE THE INTEGRITY OF GENUINE PRODUCTS AND DOCUMENTS; PROVIDING TEMPORARY USE OF NON-DOWNLOADABLE COMPUTER SOFTWARE FOR TRACKING PACKAGES OVER COMPUTER NETWORKS, INTRANETS AND THE INTERNET (U.S. CLS. 100 AND 101).

HAI-LY LAM, EXAMINING ATTORNEY

SN 85-293,545. RYAN WILLIAMS, SANTA BARBARA, CA. AND KAREN WILLIAMS, SANTA BARBARA, CA. FILED 4-13-2011.

Share Me

THE MARK CONSISTS OF STANDARD CHARACTERS WITHOUT CLAIM TO ANY PARTICULAR FONT, STYLE, SIZE, OR COLOR.

FOR PROVIDING A WEB SITE FEATURING TEMPORARY USE OF NON-DOWNLOADABLE SOFTWARE FOR EXCHANGING INFORMATION BETWEEN USERS; PROVIDING A WEBSITE FEATURING NON-DOWNLOADABLE SOFTWARE FOR EXCHANGING INFORMATION BETWEEN USERS; PROVIDING A WEBSITE FEATURING ON-LINE NON-DOWNLOADABLE SOFTWARE THAT ENABLES USERS TO COMMUNICATE AND EXCHANGE INFORMATION (U.S. CLS. 100 AND 101).

MIDGE BUTLER, EXAMINING ATTORNEY

CLASS 42—(Continued).

SN 85-293,660. DONAGHY, BRIAN P., WEST DES MOINES, IA. FILED 4-13-2011.

ACMEIS

THE MARK CONSISTS OF STANDARD CHARACTERS WITHOUT CLAIM TO ANY PARTICULAR FONT, STYLE, SIZE, OR COLOR.

FOR COMPUTER AND SOFTWARE SERVICES, NAMELY, DESIGN, CREATION, HOSTING AND MAINTENANCE OF INTERNET SITES FOR THIRD PARTIES, AND REMOTE ON-SITE MANAGEMENT OF THE INFORMATION TECHNOLOGY (IT) SYSTEMS OF OTHERS; COMPUTER SERVICES, NAMELY, REMOTE AND ON-SITE MANAGEMENT OF CLOUD AND VIRTUALIZED COMPUTING SYSTEMS AND APPLICATIONS FOR OTHERS; APPLICATION SERVICE PROVIDER, NAMELY, HOSTING, MANAGING, DEVELOPING AND MAINTAINING APPLICATIONS, SOFTWARE, WEBSITES, AND DATABASES OF OTHERS IN THE FIELDS OF BUSINESS, MARKETING, DESIGN, DATA ANALYSIS, EDITING, CONTENT DEVELOPMENT, LEGAL SERVICES, HEALTHCARE, COMMUNICATIONS, ENERGY, ENGINEERING, FINANCE, EDUCATION, AND GOVERNMENT; CLOUD AND VIRTUALIZED COMPUTING FEATURING SOFTWARE FOR USE AS INTERNET-BASED APPLICATIONS FOR USE IN DATABASE MANAGEMENT, FOR USE AS SPREADSHEETS, DOCUMENTS, AND IMAGES, FOR WORD PROCESSING, FOR FILE CREATION, FOR CONTENT EDITING, AND FOR INTERACTIVE WEBSITES; CONSULTING SERVICES IN THE FIELD OF CLOUD AND VIRTUALIZED COMPUTING; TECHNICAL CONSULTING SERVICES IN THE FIELD OF PUBLIC AND PRIVATE CLOUD AND VIRTUALIZED COMPUTING SOLUTIONS; TECHNICAL SUPPORT SERVICES, NAMELY, REMOTE AND ON-SITE INFRASTRUCTURE MANAGEMENT SERVICES FOR MONITORING, ADMINISTRATION AND MANAGEMENT OF PUBLIC AND PRIVATE CLOUD AND VIRTUALIZED COMPUTING IT, SOFTWARE, AND APPLICATION SYSTEMS; SOFTWARE DEVELOPMENT SERVICES, NAMELY, DEVELOPMENT OF SOFTWARE OPERABLE WITH CLOUD AND VIRTUALIZED COMPUTING SYSTEMS (U.S. CLS. 100 AND 101).

FIRST USE 1-3-2008; IN COMMERCE 1-3-2008.

GEOFFREY FOSDICK, EXAMINING ATTORNEY

SN 85-293,696. RED HAT, INC., RALEIGH, NC. FILED 4-13-2011.

OpenShift

THE MARK CONSISTS OF STANDARD CHARACTERS WITHOUT CLAIM TO ANY PARTICULAR FONT, STYLE, SIZE, OR COLOR.

FOR PLATFORM AS A SERVICE (PAAS) FEATURING COMPUTER SOFTWARE PLATFORMS FOR DEPLOYING, SCALING, MONITORING AND MANAGING WEB SITES, WEB SERVICES, MOBILE APPLICATION SERVICES, DATASTORES AND MESSAGING INTERCONNECTS (U.S. CLS. 100 AND 101).

ALLISON HOLTZ, EXAMINING ATTORNEY

CLASS 42—(Continued).

SN 85-293,788. DENISE STORTI-BIEMER, CAMPBELL HALL, NY. FILED 4-13-2011.



THE MARK CONSISTS OF THE STYLIZED IMAGE OF A BIRD.

FOR GRAPHIC ART DESIGN (U.S. CLS. 100 AND 101).
FIRST USE 4-8-2011; IN COMMERCE 4-8-2011.
JORDAN BAKER, EXAMINING ATTORNEY

SN 85-294,370. YOUDOCS BEAUTY, INC., DBA YOUBEAUTY, NEW YORK, NY. FILED 4-13-2011.

The Science of a Beautiful You

THE MARK CONSISTS OF STANDARD CHARACTERS WITHOUT CLAIM TO ANY PARTICULAR FONT, STYLE, SIZE, OR COLOR.

FOR COMPUTER SERVICES, NAMELY, CREATING AN ON-LINE COMMUNITY FOR REGISTERED USERS TO PARTICIPATE IN DISCUSSIONS, GET FEEDBACK FROM THEIR PEERS, FORM VIRTUAL COMMUNITIES, ENGAGE IN SOCIAL NETWORKING AND PARTICIPATE IN HEALTH AND BEAUTY RELATED QUIZZES, AS WELL AS GAMES, ALL SPECIALIZING IN CONTENT RELATED TO HEALTH AND WELLNESS AND THEIR RELATION TO BEAUTY AND TO SERVE AS THE BASIS FOR LIFE-CHANGING BEAUTY AND HEALTH PROGRAMS, FOCUSED ON HELPING USERS TO LIVE HEALTHIER LIVES (U.S. CLS. 100 AND 101).

RUSS HERMAN, EXAMINING ATTORNEY

SN 85-294,513. GERALD L. WAGNER, NEWBURGH, NY. FILED 4-13-2011.

NEXTGRID

THE MARK CONSISTS OF STANDARD CHARACTERS WITHOUT CLAIM TO ANY PARTICULAR FONT, STYLE, SIZE, OR COLOR.

FOR ENGINEERING SERVICES AND ENGINEERING CONSULTING SERVICES (U.S. CLS. 100 AND 101).

DORITT L. CARROLL, EXAMINING ATTORNEY

CLASS 42—(Continued).

SN 85-294,576. REZOLVE GROUP, INC., BOSTON, MA. FILED 4-13-2011.

ThinkAhead

THE MARK CONSISTS OF STANDARD CHARACTERS WITHOUT CLAIM TO ANY PARTICULAR FONT, STYLE, SIZE, OR COLOR.

FOR PROVIDING TEMPORARY USE OF ONLINE, NONDOWNLOADABLE SOFTWARE IN THE NATURE OF A CALCULATOR THAT HELPS USERS DETERMINE AN ESTIMATE OF A CURRENT OR PROSPECTIVE STUDENT'S INDIVIDUAL NET PRICE AT A PARTICULAR EDUCATIONAL INSTITUTION (U.S. CLS. 100 AND 101).

FIRST USE 1-31-2010; IN COMMERCE 1-31-2010.
KAREN BRACEY, EXAMINING ATTORNEY

SN 85-294,593. DIGUX, LLC, KIRKLAND, WA. FILED 4-13-2011.

DIGUX

THE MARK CONSISTS OF STANDARD CHARACTERS WITHOUT CLAIM TO ANY PARTICULAR FONT, STYLE, SIZE, OR COLOR.

FOR CONSULTING SERVICES IN THE FIELD OF DESIGN, SELECTION, IMPLEMENTATION AND USE OF COMPUTER HARDWARE AND SOFTWARE SYSTEMS FOR OTHERS (U.S. CLS. 100 AND 101).

FIRST USE 5-5-2003; IN COMMERCE 5-5-2003.
ALEX KEAM, EXAMINING ATTORNEY

SN 85-294,660. VITALY TECHNOLOGY CONSULTING, INC., CHICAGO, IL. FILED 4-13-2011.

Tech@MyDesk

THE MARK CONSISTS OF STANDARD CHARACTERS WITHOUT CLAIM TO ANY PARTICULAR FONT, STYLE, SIZE, OR COLOR.

FOR IT CONSULTING SERVICES (U.S. CLS. 100 AND 101).

FIRST USE 1-9-2003; IN COMMERCE 1-1-2007.
KATHERINE CHANG, EXAMINING ATTORNEY

CLASS 42—(Continued).

SN 85-294,665. INMAN, MELVA, DECATUR, AL. FILED 4-13-2011.

Visualriot

THE MARK CONSISTS OF STANDARD CHARACTERS WITHOUT CLAIM TO ANY PARTICULAR FONT, STYLE, SIZE, OR COLOR.

FOR GRAPHIC DESIGN; WEB SITE DESIGN; GRAPHIC DESIGN CONSULTING (U.S. CLS. 100 AND 101).
CARRIE GENOVESE, EXAMINING ATTORNEY

SN 85-294,735. GEODEX LLC, WINSTON-SALEM, NC. FILED 4-13-2011.

GeoRelevance

THE MARK CONSISTS OF STANDARD CHARACTERS WITHOUT CLAIM TO ANY PARTICULAR FONT, STYLE, SIZE, OR COLOR.

FOR COMPUTER SERVICES, NAMELY, PROVIDING TEMPORARY USE OF ONLINE NON-DOWNLOADABLE SOFTWARE FOR USE IN INTERNET RELATED SEARCHING, NAMELY, INDEXING OF WEBSITE DATA BASED ON THE GEOGRAPHICAL LOCATION OF THE USER FOR PURPOSES OF SEARCHING AND ADVERTISING IN LOCAL GEOGRAPHICAL AREAS; COMPUTER SERVICES, NAMELY, PROVIDING TEMPORARY USE OF ONLINE NON-DOWNLOADABLE SOFTWARE FOR USE IN MARKETING SERVICES, NAMELY, FOR ADVERTISING THE GOODS AND SERVICES OF OTHERS ON-LINE (U.S. CLS. 100 AND 101).
FIRST USE 4-1-2010; IN COMMERCE 4-1-2010.

GEOFFREY FOSDICK, EXAMINING ATTORNEY

CLASS 42—(Continued).

SN 85-294,739. GEODEX LLC, WINSTON-SALEM, NC. FILED 4-13-2011.

GeoPopularity

THE MARK CONSISTS OF STANDARD CHARACTERS WITHOUT CLAIM TO ANY PARTICULAR FONT, STYLE, SIZE, OR COLOR.

FOR COMPUTER SERVICES, NAMELY, PROVIDING TEMPORARY USE OF ONLINE NON-DOWNLOADABLE SOFTWARE FOR USE IN INTERNET RELATED SEARCHING, NAMELY, INDEXING OF WEBSITE DATA BASED ON THE GEOGRAPHICAL LOCATION OF THE USER FOR PURPOSES OF SEARCHING AND ADVERTISING IN LOCAL GEOGRAPHICAL AREAS; COMPUTER SERVICES, NAMELY, PROVIDING TEMPORARY USE OF ONLINE NON-DOWNLOADABLE SOFTWARE FOR USE IN MARKETING SERVICES, NAMELY, FOR ADVERTISING THE GOODS AND SERVICES OF OTHERS ON-LINE (U.S. CLS. 100 AND 101).
FIRST USE 4-1-2010; IN COMMERCE 4-1-2010.

GEOFFREY FOSDICK, EXAMINING ATTORNEY

SN 85-294,750. ADFACTOR, INC., MERRITT ISLAND, FL. FILED 4-14-2011.

ADFACTOR

THE MARK CONSISTS OF STANDARD CHARACTERS WITHOUT CLAIM TO ANY PARTICULAR FONT, STYLE, SIZE, OR COLOR.

FOR COMPUTER SERVICES, NAMELY, SEARCH ENGINE OPTIMIZATION; CREATING, DESIGNING AND MAINTAINING WEB SITES; WEB SITE HOSTING SERVICES; RENTAL OF WEB SERVERS (U.S. CLS. 100 AND 101).

FIRST USE 2-5-2009; IN COMMERCE 2-5-2009.
WILLIAM VERHOSEK, EXAMINING ATTORNEY

SN 85-295,245. PARTICLE SCIENCES, INC., BETHLEHEM, PA. FILED 4-14-2011.

WE DELIVER

THE MARK CONSISTS OF STANDARD CHARACTERS WITHOUT CLAIM TO ANY PARTICULAR FONT, STYLE, SIZE, OR COLOR.

FOR PHARMACEUTICAL DRUG DEVELOPMENT SERVICES (U.S. CLS. 100 AND 101).

ERIN FALK, EXAMINING ATTORNEY

CLASS 42—(Continued).

SN 85-295,671. DION ZUESS, PHOENIX, AZ. FILED 4-14-2011.

CLASS 42—(Continued).

SN 85-296,611. GERALD L. WAGNER, NEWBURGH, NY. FILED 4-15-2011.

ecoLingo



THE MARK CONSISTS OF STANDARD CHARACTERS WITHOUT CLAIM TO ANY PARTICULAR FONT, STYLE, SIZE, OR COLOR.

SEC. 2(F).
FOR ENVIRONMENTALLY CONSCIOUS GRAPHIC ART DESIGN SERVICES (U.S. CLS. 100 AND 101).
FIRST USE 4-22-2003; IN COMMERCE 6-9-2004.
JOHN HWANG, EXAMINING ATTORNEY

THE MARK CONSISTS OF THE WORDS "NEXTGRID" NEXT TO A FIVE BY FIVE SQUARE GRID HAVING CURVED UPPER AND RIGHT EDGES, PROVIDING THE ILLUSION OF THE UPPER-RIGHT CORNER OF THE GRID CURLING AWAY FROM THE VIEWER, AND HAVING SHADING GOING FROM LIGHT AT THE LOWER-LEFT CORNER TO DARK IN THE UPPER-RIGHT CORNER.

FOR ENGINEERING SERVICES AND ENGINEERING CONSULTING SERVICES (U.S. CLS. 100 AND 101).
DORITT L. CARROLL, EXAMINING ATTORNEY

SN 85-296,486. GERALD L. WAGNER, NEWBURGH, NY. FILED 4-15-2011.

SN 85-296,940. BOREN, STEVEN, SCOTTSDALE, AZ. FILED 4-15-2011.

TheWayGo.com

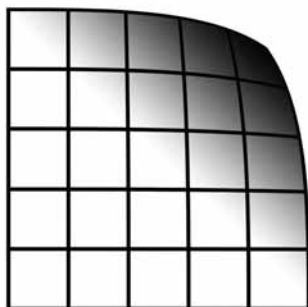

THE MARK CONSISTS OF STANDARD CHARACTERS WITHOUT CLAIM TO ANY PARTICULAR FONT, STYLE, SIZE, OR COLOR.

FOR PROVIDING VIRTUAL COMPUTER SYSTEMS AND VIRTUAL COMPUTER ENVIRONMENTS THROUGH CLOUD COMPUTING (U.S. CLS. 100 AND 101).

JOHN GARTNER, EXAMINING ATTORNEY

SN 85-298,299. WTEC, FORT LEE, NJ. FILED 4-19-2011.

SOLARTEC

THE MARK CONSISTS OF A FIVE BY FIVE SQUARE GRID HAVING CURVED UPPER AND RIGHT EDGES, PROVIDING THE ILLUSION OF THE UPPER-RIGHT CORNER OF THE GRID CURLING AWAY FROM THE VIEWER, AND HAVING SHADING GOING FROM LIGHT AT THE LOWER-LEFT CORNER TO DARK IN THE UPPER-RIGHT CORNER.

FOR ENGINEERING SERVICES AND ENGINEERING CONSULTING SERVICES (U.S. CLS. 100 AND 101).
DORITT L. CARROLL, EXAMINING ATTORNEY

THE MARK CONSISTS OF STANDARD CHARACTERS WITHOUT CLAIM TO ANY PARTICULAR FONT, STYLE, SIZE, OR COLOR.

FOR ENGINEERING OF WIND AND SOLAR FARM SYSTEMS (U.S. CLS. 100 AND 101).

FIRST USE 1-15-2011; IN COMMERCE 1-15-2011.
ELLEN BURNS, EXAMINING ATTORNEY

CLASS 42—(Continued).

SN 85-305,844. MEREDITH CORPORATION, DES MOINES, IA. FILED 4-27-2011.

**THIS STUFF WORKS BEAUTY
AWARD**

THE MARK CONSISTS OF STANDARD CHARACTERS WITHOUT CLAIM TO ANY PARTICULAR FONT, STYLE, SIZE, OR COLOR.

NO CLAIM IS MADE TO THE EXCLUSIVE RIGHT TO USE "AWARD", APART FROM THE MARK AS SHOWN.

FOR TESTING, ANALYSIS AND EVALUATION OF THE GOODS OF OTHERS FOR PURPOSES OF AN AWARD (U.S. CLS. 100 AND 101).

FIRST USE 3-1-2011; IN COMMERCE 3-1-2011.

NAAKWAMA ANKRAH, EXAMINING ATTORNEY

CLASS 42—(Continued).

SN 85-309,796. BACKCHANNELMEDIA, INC., SUMMIT, NJ. FILED 5-2-2011.



THE MARK CONSISTS OF THE WORDS "ONYX VANTAGE" WITH THE WORD "ONYX" INSIDE A RECTANGULAR SHAPE.

FOR NON-DOWNLOADABLE WEB-BASED SOFTWARE APPLICATION THAT ALLOWS MANAGEMENT AND REPORTING OF INTERACTIVE EVENTS IN TELEVISION PROGRAMMING AND ADVERTISEMENT (U.S. CLS. 100 AND 101).

FIRST USE 4-29-2011; IN COMMERCE 4-29-2011.

H. M. FISHER, EXAMINING ATTORNEY

SN 85-307,993. SEPRO CORPORATION, CARMEL, IN. FILED 4-29-2011.

FasTEST

THE MARK CONSISTS OF STANDARD CHARACTERS WITHOUT CLAIM TO ANY PARTICULAR FONT, STYLE, SIZE, OR COLOR.

FOR ANALYTICAL TESTING FOR ANALYSIS OF AQUATIC HERBICIDE AND ALGAECIDE CONCENTRATIONS IN WATER (U.S. CLS. 100 AND 101).

FIRST USE 7-1-1996; IN COMMERCE 7-1-1996.

GISELLE AGOSTO, EXAMINING ATTORNEY

SN 85-309,805. BACKCHANNELMEDIA, INC., SUMMIT, NJ. FILED 5-2-2011.

ONYX VANTAGE

SN 85-309,585. A.S.A.P. ADVISOR SERVICES, INC., NEW YORK, NY. FILED 5-2-2011.

map 'n meet

THE MARK CONSISTS OF STANDARD CHARACTERS WITHOUT CLAIM TO ANY PARTICULAR FONT, STYLE, SIZE, OR COLOR.

FOR SOFTWARE AS A SERVICE, NAMELY NON-DOWNLOADABLE SOFTWARE FOR USE IN PROVIDING BUSINESS CLIENT RESOURCE MANAGEMENT SERVICES (U.S. CLS. 100 AND 101).

GINA HAYES, EXAMINING ATTORNEY

THE MARK CONSISTS OF STANDARD CHARACTERS WITHOUT CLAIM TO ANY PARTICULAR FONT, STYLE, SIZE, OR COLOR.

FOR NON-DOWNLOADABLE WEB-BASED SOFTWARE APPLICATION THAT ALLOWS MANAGEMENT AND REPORTING OF INTERACTIVE EVENTS IN TELEVISION PROGRAMMING AND ADVERTISEMENT (U.S. CLS. 100 AND 101).

FIRST USE 4-29-2011; IN COMMERCE 4-29-2011.

H. M. FISHER, EXAMINING ATTORNEY

CLASS 42—(Continued).

SN 85-312,859. ZWCAD SOFTWARE CO., LTD., GUANGZHOU, GUANGDONG, CHINA, FILED 5-5-2011.

ZWISOFT

OWNER OF U.S. REG. NO. 3,612,724.
NO CLAIM IS MADE TO THE EXCLUSIVE RIGHT TO USE "SOFT", APART FROM THE MARK AS SHOWN.

THE MARK CONSISTS OF THE WORDING "ZW" AND "SOFT", WITH A TRIANGLE DESIGN ON THE UPPER RIGHT ARM OF THE "W".

FOR COMPUTER PROGRAMMING; COMPUTER SOFTWARE DESIGN; COMPUTER SOFTWARE DESIGN AND UPDATING; CONSTRUCTION DRAFTING; CREATING, DESIGNING AND MAINTAINING WEB SITES; CREATION, DESIGN, DEVELOPMENT AND MAINTENANCE OF WEB SITES FOR THIRD PARTIES; DESIGN AND DEVELOPMENT OF ELECTRONIC DATA SECURITY SYSTEMS; DESIGN AND DEVELOPMENT OF FILMS AND SHEETS USED IN THE MANUFACTURING OF PRINTED CIRCUIT BOARDS; DESIGN OF APPARATUS AND MACHINES IN THE FIELD OF FILLING; DESIGN OF INTERIOR DECOR; DEVELOPING AND UPDATING COMPUTER SOFTWARE; DEVELOPMENT OF COMPUTER PROGRAMS RECORDED ON DATA MEDIA (SOFTWARE) DESIGNED FOR USE IN CONSTRUCTION AND AUTOMATED MANUFACTURING (CAD/CAM); GRAPHIC ILLUSTRATION AND DRAWING SERVICES, NAMELY, PROVIDING GRAPHIC ILLUSTRATIONS AND DRAWINGS OF COMMERCIAL AND INDUSTRIAL BUILDING DESIGNS, AND CONVERTING BUILDING DESIGNS OR MARKUPS TO ELECTRONIC CAD DRAWINGS; INDUSTRIAL DESIGN; MECHANICAL ENGINEERING; MECHANICAL RESEARCH; PACKAGING DESIGN (U.S. CLS. 100 AND 101).

FIRST USE 8-24-1998; IN COMMERCE 2-8-2004.
DAVID HOFFMAN, EXAMINING ATTORNEY

SN 85-313,088. THOMSON REUTERS CANADA LIMITED, TORONTO, CANADA, FILED 5-5-2011.

THOMSON REUTERS RESEARCH
IN VIEW

THE MARK CONSISTS OF STANDARD CHARACTERS WITHOUT CLAIM TO ANY PARTICULAR FONT, STYLE, SIZE, OR COLOR.

OWNER OF U.S. REG. NOS. 2,086,780, 3,538,823 AND OTHERS.

FOR PROVIDING AN ONLINE DATABASE THAT AGGREGATES AND STANDARDIZES DATA FROM DISPARATE SOURCES TO PROVIDE A UNIFIED DATABASE AND ANALYTIC INTERFACE FOR MANAGING, SEARCHING AND REPORTING ON UNIVERSITY'S TEACHING AND RESEARCH ACTIVITIES AND PERFORMANCE (U.S. CLS. 100 AND 101).

FIRST USE 3-1-2011; IN COMMERCE 3-1-2011.
DOUGLAS LEE, EXAMINING ATTORNEY

CLASS 42—(Continued).

SN 85-313,950. FAMILY SERVICE AGENCY OF SAN FRANCISCO, SAN FRANCISCO, CA. FILED 5-6-2011.

CIRCE

THE MARK CONSISTS OF STANDARD CHARACTERS WITHOUT CLAIM TO ANY PARTICULAR FONT, STYLE, SIZE, OR COLOR.

FOR PROVIDING ON-LINE NON-DOWNLOADABLE SOFTWARE FOR USE IN DATABASE ACCESS AND MANAGEMENT IN THE FIELD OF MEDICAL RECORDS, CHARTING AND BILLING; CLOUD COMPUTING FEATURING SOFTWARE FOR USE IN DATABASE ACCESS AND MANAGEMENT IN THE FIELD OF MEDICAL RECORDS, CHARTING AND BILLING (U.S. CLS. 100 AND 101).

FIRST USE 6-1-2010; IN COMMERCE 6-1-2010.
GISELLE AGOSTO, EXAMINING ATTORNEY

SN 85-320,301. HILL-ROM SERVICES, INC., BATESVILLE, IN. FILED 5-13-2011.

TOTAL ROOM SOLUTION

THE MARK CONSISTS OF STANDARD CHARACTERS WITHOUT CLAIM TO ANY PARTICULAR FONT, STYLE, SIZE, OR COLOR.

NO CLAIM IS MADE TO THE EXCLUSIVE RIGHT TO USE "ROOM SOLUTION", APART FROM THE MARK AS SHOWN.

FOR HEALTHCARE FACILITY DESIGN SERVICES; HEALTHCARE FACILITY LAYOUT TECHNICAL CONSULTATION SERVICES (U.S. CLS. 100 AND 101).

CYNTHIA SLOAN, EXAMINING ATTORNEY

SN 85-324,295. INVERTIX CORPORATION, MCLEAN, VA. FILED 5-18-2011.

IF

THE MARK CONSISTS OF STANDARD CHARACTERS WITHOUT CLAIM TO ANY PARTICULAR FONT, STYLE, SIZE, OR COLOR.

FOR PROVIDING VIRTUAL COMPUTER SYSTEMS AND VIRTUAL COMPUTER ENVIRONMENTS THROUGH CLOUD COMPUTING (U.S. CLS. 100 AND 101).

SALLY SHIH, EXAMINING ATTORNEY

CLASS 42—(Continued).

SN 85-338,453. CHROME SYSTEMS, INC., PORTLAND, OR.
FILED 6-6-2011.

FINANCEDRIVER

THE MARK CONSISTS OF STANDARD CHARACTERS WITHOUT CLAIM TO ANY PARTICULAR FONT, STYLE, SIZE, OR COLOR.

FOR PROVIDING TEMPORARY USE OF NON-DOWNLOADABLE SOFTWARE FOR CUSTOMERS TO GET PRE-APPROVED AND/OR APPLY FOR CREDIT FOR AN AUTOMOBILE PURCHASE OR LEASE VIA THE INTERNET (U.S. CLS. 100 AND 101).

LIEF MARTIN, EXAMINING ATTORNEY

SN 85-338,454. CHROME SYSTEMS, INC., PORTLAND, OR.
FILED 6-6-2011.

DEALDRIVER

THE MARK CONSISTS OF STANDARD CHARACTERS WITHOUT CLAIM TO ANY PARTICULAR FONT, STYLE, SIZE, OR COLOR.

FOR PROVIDING TEMPORARY USE OF NON-DOWNLOADABLE SOFTWARE FOR THE FACILITATION AND ONLINE NEGOTIATION AND AGREEMENT BETWEEN VEHICLE RETAILER AND CONSUMER FOR THE PURCHASE OF A VEHICLE (U.S. CLS. 100 AND 101).

LIEF MARTIN, EXAMINING ATTORNEY

CLASS 43—HOTEL AND RESTAURANT SERVICES

SN 76-685,731. TAKAYAMA, MASAYOSHI, NEW YORK, NY.
FILED 1-14-2008.

MASA

THE MARK CONSISTS OF STANDARD CHARACTERS WITHOUT CLAIM TO ANY PARTICULAR FONT, STYLE, SIZE, OR COLOR.

FOR JAPANESE AND SUSHI RESTAURANT AND BAR SERVICES (U.S. CLS. 100 AND 101).

FIRST USE 1-0-2004; IN COMMERCE 1-0-2004.

COLLEEN DOMBROW, EXAMINING ATTORNEY

CLASS 43—(Continued).

SN 77-684,560. STINGRAY HOLDING COMPANY, LLC,
SCOTTSDALE, AZ. FILED 3-5-2009.



NO CLAIM IS MADE TO THE EXCLUSIVE RIGHT TO USE "SUSHI", APART FROM THE MARK AS SHOWN.

THE COLOR(S) BLUE, ORANGE AND RED IS/ARE CLAIMED AS A FEATURE OF THE MARK.

THE MARK CONSISTS OF THE DESIGN OF A DASYATIDAE IN BLUE ABOVE THE WORD "STINGRAY" IN ORANGE LETTERING OUTLINED IN RED. THE WORD "STINGRAY" IS ABOVE THE WORD "SUSHI" IN BLUE LETTERING.

FOR PROVIDING A COMBINATION OF JAPANESE SUSHI AND LATIN FLAIR CUISINE AND DRINKS FOR OTHERS (U.S. CLS. 100 AND 101).

FIRST USE 1-13-2005; IN COMMERCE 1-13-2005.

MICHAEL W. BAIRD, EXAMINING ATTORNEY

SN 77-732,247. BISSELL HOTELS, INC., CHARLOTTE, NC.
FILED 5-8-2009.

BALLANTYNE HOTEL & LODGE

THE MARK CONSISTS OF STANDARD CHARACTERS WITHOUT CLAIM TO ANY PARTICULAR FONT, STYLE, SIZE, OR COLOR.

OWNER OF U.S. REG. NO. 2,714,775.

NO CLAIM IS MADE TO THE EXCLUSIVE RIGHT TO USE "HOTEL & LODGE", APART FROM THE MARK AS SHOWN.

SEC. 2(F).

FOR HOTEL SERVICES AND CATERING SERVICES (U.S. CLS. 100 AND 101).

JESSICA A. POWERS, EXAMINING ATTORNEY

SN 79-091,092. ETRO S.P.A., ITALY, FILED 5-27-2010.

ETRO

THE MARK CONSISTS OF STANDARD CHARACTERS WITHOUT CLAIM TO ANY PARTICULAR FONT, STYLE, SIZE, OR COLOR.

OWNER OF INTERNATIONAL REGISTRATION 0915140 DATED 11-23-2006, EXPIRES 11-23-2016.

OWNER OF U.S. REG. NOS. 1,386,792, 3,882,762 AND OTHERS.

FOR SERVICES FOR PROVIDING FOOD AND DRINK, NAMELY, RESTAURANTS, FAST-FOODS, BAR AND BREAKFAST BAR, CATERING SERVICES; PROVIDING TEMPORARY ACCOMMODATION (U.S. CLS. 100 AND 101).

RAUL CORDOVA, EXAMINING ATTORNEY

CLASS 43—(Continued).

SN 79-092,730. NADINE SETZ, SWITZERLAND, FILED 12-13-2010.

LUNCH IS FOR LOSERS

THE MARK CONSISTS OF STANDARD CHARACTERS WITHOUT CLAIM TO ANY PARTICULAR FONT, STYLE, SIZE, OR COLOR.

PRIORITY DATE OF 10-28-2010 IS CLAIMED.

OWNER OF INTERNATIONAL REGISTRATION 1065606 DATED 12-13-2010, EXPIRES 12-13-2020.

FOR SERVICES FOR PROVIDING FOOD AND DRINK; TEMPORARY ACCOMMODATION (U.S. CLS. 100 AND 101).

KELLY TRUSILO, EXAMINING ATTORNEY

CLASS 43—(Continued).

SN 85-045,090. THE MARMARA INC., NEW YORK, NY. FILED 5-21-2010.

THE MARMARA

SN 79-096,499. GAJA SOCIETÀ SEMPLICE, ITALY, FILED 3-3-2011.

GAJA

THE MARK CONSISTS OF STANDARD CHARACTERS WITHOUT CLAIM TO ANY PARTICULAR FONT, STYLE, SIZE, OR COLOR.

FOR HOTEL SERVICES AND RESIDENTIAL HOTEL SERVICES (U.S. CLS. 100 AND 101).

FIRST USE 3-1-1998; IN COMMERCE 3-1-1998.

MARILYN IZZI, EXAMINING ATTORNEY

THE MARK CONSISTS OF STANDARD CHARACTERS WITHOUT CLAIM TO ANY PARTICULAR FONT, STYLE, SIZE, OR COLOR.

PRIORITY DATE OF 2-25-2011 IS CLAIMED.

OWNER OF INTERNATIONAL REGISTRATION 1074742 DATED 3-3-2011, EXPIRES 3-3-2021.

THE ENGLISH TRANSLATION OF "GAJA" IN THE MARK IS "MERRY" OR "GLAD".

FOR SERVICES FOR PROVIDING FOOD AND DRINK; TEMPORARY ACCOMMODATION (U.S. CLS. 100 AND 101).

ALYSSA STEEL, EXAMINING ATTORNEY

SN 85-068,428. NELLO (FOOD), LLC, WILMINGTON, DE. FILED 6-22-2010.

NELLO

SN 85-026,546. DELI MANAGEMENT, INC., BEAUMONT, TX. FILED 4-29-2010.



NO CLAIM IS MADE TO THE EXCLUSIVE RIGHT TO USE "CAFE", APART FROM THE MARK AS SHOWN.

THE MARK CONSISTS OF THE WORDS "JASON'S CAFE" SUPERIMPOSED ON AN OVAL BACKGROUND.

FOR RESTAURANTS (U.S. CLS. 100 AND 101).

FIRST USE 1-0-2009; IN COMMERCE 1-0-2009.

ANTHONY RINKER, EXAMINING ATTORNEY

THE MARK CONSISTS OF STANDARD CHARACTERS WITHOUT CLAIM TO ANY PARTICULAR FONT, STYLE, SIZE, OR COLOR.

FOR RESTAURANT SERVICES (U.S. CLS. 100 AND 101).

FIRST USE 0-0-1990; IN COMMERCE 0-0-1990.

NICHOLAS COLEMAN, EXAMINING ATTORNEY

CLASS 43—(Continued).

SN 85-085,384. WEI XING LIN, DBA TENZAN NEW YORK, BROOKLYN, NY. FILED 7-15-2010.



NO CLAIM IS MADE TO THE EXCLUSIVE RIGHT TO USE "JAPANESE CUISINE", APART FROM THE MARK AS SHOWN.

THE MARK CONSISTS OF THE TERM "TENZAN" IN STYLIZED LETTERING ABOVE THE WORDING "JAPANESE CUISINE" WHICH IS ABOVE THE DESIGN OF TWO FISH IN A CIRCLE BORDER. ABOVE THE LAST LETTER "N" IN THE TERM "TENZAN" ARE TWO STYLIZED CHINESE LETTERS.

THE ENGLISH TRANSLATION OF "TENZAN" IN THE MARK IS "HEAVENLY MOUNTAIN".

THE NON-LATIN CHARACTERS IN THE MARK TRANSLITERATE TO "TENZAN" AND THIS MEANS "HEAVENLY MOUNTAIN" IN ENGLISH.

FOR BAR AND RESTAURANT SERVICES (U.S. CLS. 100 AND 101).

FIRST USE 7-1-2003; IN COMMERCE 7-1-2003.

ANDREA K. NADELMAN, EXAMINING ATTORNEY

SN 85-111,541. MIDWEST GAMING & ENTERTAINMENT, LLC, CHICAGO, IL. FILED 8-19-2010.

P'ZA

THE MARK CONSISTS OF STANDARD CHARACTERS WITHOUT CLAIM TO ANY PARTICULAR FONT, STYLE, SIZE, OR COLOR.

FOR RESTAURANT SERVICES (U.S. CLS. 100 AND 101).

JEFFERY COWARD, EXAMINING ATTORNEY

CLASS 43—(Continued).

SN 85-117,893. FAT SAL'S LICENSING, LLC, LOS ANGELES, CA. FILED 8-27-2010.

Fat Sal's

THE MARK CONSISTS OF STANDARD CHARACTERS WITHOUT CLAIM TO ANY PARTICULAR FONT, STYLE, SIZE, OR COLOR.

THE NAME "FAT SAL" IDENTIFIES SALVATORE CAPEK A LIVING INDIVIDUAL WHOSE CONSENT IS OF RECORD.

FOR DELICATESSENS (U.S. CLS. 100 AND 101).

HEATHER BIDDULPH, EXAMINING ATTORNEY

SN 85-124,385. TMTD, LLC, CHARLOTTE, NC. FILED 9-7-2010.



NO CLAIM IS MADE TO THE EXCLUSIVE RIGHT TO USE "CLUB", APART FROM THE MARK AS SHOWN.

THE COLOR(S) WHITE, ORANGE, RED, YELLOW AND BLUE IS/ARE CLAIMED AS A FEATURE OF THE MARK.

THE MARK CONSISTS OF THE WORDS "THE GOOD LIFE CLUB" IN STYLIZED FONT WITH THE WORD "THE" APPEARING IN YELLOW ABOVE THE WORD "GOOD" APPEARING IN RED, BOTH OF WHICH APPEAR TO THE LEFT OF THE WORD "LIFE" WITH THE LETTER "L" APPEARING IN ORANGE, THE LETTER "I" APPEARING IN RED, THE LETTER "F" APPEARING IN YELLOW AND THE LETTER "E" APPEARING IN BLUE. AND THE WORD "CLUB" APPEARING IN WHITE ABOVE THE BACKGROUND OF A BLUE RECTANGLE APPEARING UNDER THE WORD "LIFE".

FOR BAR AND RESTAURANT SERVICES (U.S. CLS. 100 AND 101).

JUSTINE D. PARKER, EXAMINING ATTORNEY

SN 85-124,988. VINCENT RIPP, RICHMOND, VA. FILED 9-8-2010.

RIO TANGO

THE MARK CONSISTS OF STANDARD CHARACTERS WITHOUT CLAIM TO ANY PARTICULAR FONT, STYLE, SIZE, OR COLOR.

FOR RESTAURANT AND BAR (U.S. CLS. 100 AND 101).

HEATHER BIDDULPH, EXAMINING ATTORNEY

CLASS 43—(Continued).

SN 85-126,296. LSC RESTAURANT MANAGEMENT GROUP, INC., NEW YORK, NY. FILED 9-9-2010.

CENTOLIRE

THE MARK CONSISTS OF STANDARD CHARACTERS WITHOUT CLAIM TO ANY PARTICULAR FONT, STYLE, SIZE, OR COLOR.

THE ENGLISH TRANSLATION OF "CENTOLIRE" IN THE MARK IS "ONE HUNDRED LIRE".

FOR RESTAURANTS (U.S. CLS. 100 AND 101).
FIRST USE 1-0-2001; IN COMMERCE 3-21-2001.

WILLIAM ROSSMAN, EXAMINING ATTORNEY

SN 85-126,630. STOKESAY CASTLE LLC, READING, PA. FILED 9-10-2010.

Stokesay Castle

THE MARK CONSISTS OF STANDARD CHARACTERS WITHOUT CLAIM TO ANY PARTICULAR FONT, STYLE, SIZE, OR COLOR.

FOR RESTAURANT, BAR AND CATERING SERVICES (U.S. CLS. 100 AND 101).

FIRST USE 11-1-2009; IN COMMERCE 11-1-2009.

SUNG IN, EXAMINING ATTORNEY

SN 85-129,652. GROUP 7 ENTERPRISES, LLC, LOS ANGELES, CA. FILED 9-14-2010.

URBAN SPIRITS

THE MARK CONSISTS OF STANDARD CHARACTERS WITHOUT CLAIM TO ANY PARTICULAR FONT, STYLE, SIZE, OR COLOR.

NO CLAIM IS MADE TO THE EXCLUSIVE RIGHT TO USE "SPIRITS", APART FROM THE MARK AS SHOWN.

FOR BAR AND COCKTAIL LOUNGE SERVICES; BAR AND RESTAURANT SERVICES; COFFEE BARS; RESTAURANT, BAR AND CATERING SERVICES (U.S. CLS. 100 AND 101).

ANGELA DUONG, EXAMINING ATTORNEY

CLASS 43—(Continued).

SN 85-131,295. GOURMET MFG, SAN PEDRO, NUEVO LEONE, MEXICO, FILED 9-16-2010.



NO CLAIM IS MADE TO THE EXCLUSIVE RIGHT TO USE "GOURMET", APART FROM THE MARK AS SHOWN. THE MARK CONSISTS OF STYLIZED SCRIPT OF THE WORDS "CON DOLCEZZA GOURMET".

THE ENGLISH TRANSLATION OF "CON DOLCEZZA" IN THE MARK IS "WITH SWEETNESS".

FOR PREPARATION OF FOOD AND BEVERAGES; RESTAURANT SERVICES FEATURING GOURMET FOOD; RESTAURANT SERVICES, NAMELY, PROVIDING OF FOOD AND BEVERAGES FOR CONSUMPTION ON AND OFF THE PREMISES (U.S. CLS. 100 AND 101).
SUNG IN, EXAMINING ATTORNEY

SN 85-139,330. KATS ON MARKET, INC., DBA THE TAVERN HOSPITALITY GROUP, DENVER, CO. FILED 9-27-2010.



NO CLAIM IS MADE TO THE EXCLUSIVE RIGHT TO USE "TAVERN", APART FROM THE MARK AS SHOWN.

THE MARK CONSISTS OF THE WORDING "THE TAVERN LOWRY"; THE LETTER "V" IS A STYLIZED COCKTAIL GLASS; A TOOTHPICK AND A STYLIZED OLIVE DESIGN APPEARS ABOVE THE STYLIZED COCKTAIL GLASS; AND HORIZONTALLY BETWEEN THE WORDS "TAVERN" AND "LOWRY" APPEARS A SWOOSH DESIGN.

SEC. 2(F) AS TO "THE TAVERN LOWRY".
FOR BAR AND RESTAURANT SERVICES (U.S. CLS. 100 AND 101).

FIRST USE 7-1-2006; IN COMMERCE 7-1-2006.

BILL DAWE, EXAMINING ATTORNEY

CLASS 43—(Continued).

SN 85-143,947. SUSUMI INVESTMENTS, LLC, EL PASO, TX.
FILED 10-3-2010.

AKARI
JAPANESE BISTRO

NO CLAIM IS MADE TO THE EXCLUSIVE RIGHT TO USE "JAPANESE BISTRO", APART FROM THE MARK AS SHOWN.

THE MARK CONSISTS OF "AKARI JAPANESE BISTRO". THE ENGLISH TRANSLATION OF "AKARI" IN THE MARK IS "LIGHT".

FOR BAR AND RESTAURANT SERVICES; CARRY-OUT RESTAURANTS; FAST-FOOD RESTAURANT SERVICES; FAST-FOOD RESTAURANTS; MOBILE RESTAURANT SERVICES; PROVISION OF FOOD AND DRINK IN RESTAURANTS; RESERVATION OF RESTAURANTS; RESTAURANT; RESTAURANT AND BAR SERVICES; RESTAURANT AND BAR SERVICES, INCLUDING RESTAURANT CARRYOUT SERVICES; RESTAURANT AND CAFE SERVICES; RESTAURANT AND CATERING SERVICES; RESTAURANT SERVICES; RESTAURANT SERVICES FEATURING JAPANESE FOOD; RESTAURANT SERVICES, INCLUDING SIT-DOWN SERVICE OF FOOD AND TAKE-OUT RESTAURANT SERVICES; RESTAURANT SERVICES, NAMELY, PROVIDING OF FOOD AND BEVERAGES FOR CONSUMPTION ON AND OFF THE PREMISES; RESTAURANT, BAR AND CATERING SERVICES; RESTAURANTS; RESTAURANTS FEATURING HOME DELIVERY; TAKE-OUT RESTAURANT SERVICES (U.S. CLS. 100 AND 101).

FIRST USE 3-1-2010; IN COMMERCE 3-8-2010.
BRIAN CALLAGHAN, EXAMINING ATTORNEY

CLASS 43—(Continued).

SN 85-155,632. MORE INTELLIGENT FOODS INC., DUBAI, UNITED ARAB EMIR., FILED 10-19-2010.



OWNER OF UNITED ARAB EMIR. REG. NO. 991199, DATED 1-4-2010, EXPIRES 11-13-2016.

NO CLAIM IS MADE TO THE EXCLUSIVE RIGHT TO USE "CAFE", APART FROM THE MARK AS SHOWN.

THE MARK CONSISTS OF THE WORD "MORE" WITH THE "O" IN A LARGER TYPE FONT THAN THE REST OF THE WORD, AND THE WORD "CAFE" BELOW IN SMALLER LETTERS, ALL ON A DARK RECTANGULAR BACKGROUND.

FOR SERVING OF FOOD AND BEVERAGES; PROVIDING TEMPORARY LODGING SERVICES IN THE NATURE OF A MOTEL OR HOTEL; CAFE; CAFETERIAS; CATERING; RESTAURANTS (U.S. CLS. 100 AND 101).

JOHN WILKE, EXAMINING ATTORNEY

SN 85-159,058. FOTM FRANCHISE, INC., PORTLAND, OR.
FILED 10-22-2010.

SN 85-149,373. CIM/OAKLAND CITY CENTER LLC, LOS ANGELES, CA. FILED 10-11-2010.

FIRE ON THE MOUNTAIN**LEVEL TWO FOOD & FRIENDS**

THE MARK CONSISTS OF STANDARD CHARACTERS WITHOUT CLAIM TO ANY PARTICULAR FONT, STYLE, SIZE, OR COLOR.

FOR BAR AND RESTAURANT SERVICES (U.S. CLS. 100 AND 101).

ODESSA BIBBINS, EXAMINING ATTORNEY

THE MARK CONSISTS OF STANDARD CHARACTERS WITHOUT CLAIM TO ANY PARTICULAR FONT, STYLE, SIZE, OR COLOR.

FOR RESTAURANT SERVICES FEATURING BUFFALO CHICKEN WINGS, BARBECUE SAUCES, CHICKEN SANDWICHES, CHICKEN SALADS (U.S. CLS. 100 AND 101).

FIRST USE 1-1-2005; IN COMMERCE 1-1-2005.
BENJAMIN OKEKE, EXAMINING ATTORNEY

CLASS 43—(Continued).

SN 85-159,076. FOTM FRANCHISE, INC., PORTLAND, OR. FILED 10-22-2010.



NO CLAIM IS MADE TO THE EXCLUSIVE RIGHT TO USE "BUFFALO WINGS", APART FROM THE MARK AS SHOWN.

THE MARK CONSISTS OF A DARK CIRCLE OUTLINE WITH A LIGHTER INNER CIRCLE CONTAINING THE STYLIZED WORDING "FIRE ON THE MOUNTAIN BUFFALO WINGS" IN AN ARCHED ARRANGEMENT; ABOVE THIS TEXT IS THE DESIGN OF A VOLCANO ERUPTING IN FLAMES.

FOR RESTAURANT SERVICES FEATURING BUFFALO CHICKEN WINGS, BARBECUE SAUCES, CHICKEN SANDWICHES, CHICKEN SALADS (U.S. CLS. 100 AND 101).

FIRST USE 1-1-2005; IN COMMERCE 1-1-2005.
BENJAMIN OKEKE, EXAMINING ATTORNEY

CLASS 43—(Continued).

SN 85-173,023. MACSJJ, LLC., TORRANCE, CA. FILED 11-9-2010.



OWNER OF U.S. REG. NOS. 3,492,713 AND 3,894,807.

NO CLAIM IS MADE TO THE EXCLUSIVE RIGHT TO USE "POLLO" AND "EXPRESS", APART FROM THE MARK AS SHOWN.

THE COLOR(S) YELLOW, RED, BLACK, WHITE AND ORANGE IS/ARE CLAIMED AS A FEATURE OF THE MARK.

THE MARK CONSISTS OF A CHICKEN DESIGN FEATURING THE BUST OF A CHICKEN IN PALE YELLOW SURROUNDED BY THE FRAME OF A STONE WINDOW IN RED. THE CHICKEN HAS A RED COMB ON TOP OF IT'S HEAD AND IS WEARING A RED HEADBAND WITH A WHITE FEATHER. THE CHICKEN HAS AN ORANGE BEAK AND A RED WADDLE UNDERNEATH IT'S CHIN AND IS WEARING A BIB WITH BLACK AND WHITE DESIGN ON IT. THE WORDS "POLLO INKA" ARE PLACED UNDERNEATH THE WINDOW IN RED IN A STAGGERED AND PAINTED EFFECT AND THE WORD "EXPRESS" IS PLACED UNDERNEATH "POLLO INKA" IN RED ITALIC LETTERS. THE DESIGN OF THE CHICKEN BUST IN THE RED FRAME OF THE WINDOW IS ENCASED WITHIN A YELLOW SQUARE.

THE ENGLISH TRANSLATION OF "POLLO" IN THE MARK IS "CHICKEN".

FOR RESTAURANT, CARRY-OUT FOOD AND BAR SERVICES (U.S. CLS. 100 AND 101).

KELLY TRUSILO, EXAMINING ATTORNEY

SN 85-167,601. MASON, BRADLEY R., CARLSBAD, CA. FILED 11-2-2010.



OWNER OF U.S. REG. NO. 3,912,091.

NO CLAIM IS MADE TO THE EXCLUSIVE RIGHT TO USE "STONE", APART FROM THE MARK AS SHOWN.

THE COLOR(S) BLACK, GRAY, WHITE AND ORANGE IS/ARE CLAIMED AS A FEATURE OF THE MARK.

THE MARK CONSISTS OF THE STYLIZED WORDING "STONE FLATS" IN BLACK, A STYLIZED FLAME ABOVE THESE WORDS HAVING A BLACK BORDER, AN ORANGE MID-SECTION, AND A WHITE CENTER WITH A GRAY FRAMED HEARTH SURROUNDING THE CORNERS OF THE FLAME.

FOR CAFE AND RESTAURANT SERVICES (U.S. CLS. 100 AND 101).

BERYL GARDNER, EXAMINING ATTORNEY

CLASS 43—(Continued).

SN 85-183,223. PUERTO MADERO INTERNATIONAL, LLC, MIAMI, FL. FILED 11-23-2010.



NO CLAIM IS MADE TO THE EXCLUSIVE RIGHT TO USE "BUENOS AIRES," "STEAK & FISH" AND "HOUSE", APART FROM THE MARK AS SHOWN.

THE MARK CONSISTS OF AN OVAL WITH AN BLACK BORDER ABOVE A RECTANGLE WITH A BLACK BORDER. THE BORDER OF THE OVAL CONTAINS SIX SCREW DESIGNS. THE BORDER OF THE RECTANGLE CONTAINS TWO SCREW DESIGNS. THE OVAL CONTAINS THE WORDING "PM BUENOS AIRES". THE RECTANGLE CONTAINS THE WORDING "STEAK & FISH HOUSE" WITH A BULLET SEPARATING THE WORDS "FISH" AND "HOUSE".

FOR SERVICES FOR PROVIDING FOOD AND DRINK, NAMELY, RESTAURANT SERVICES (U.S. CLS. 100 AND 101).

DEIRDRE ROBERTSON, EXAMINING ATTORNEY

SN 85-190,416. CBS BROADCASTING INC., NEW YORK, NY. FILED 12-3-2010.

**JETHRO BODINE'S BEVERLY
HILLBILLIES MANSION &
CASINO**

THE MARK CONSISTS OF STANDARD CHARACTERS WITHOUT CLAIM TO ANY PARTICULAR FONT, STYLE, SIZE, OR COLOR.

OWNER OF U.S. REG. NOS. 3,002,477, 3,510,103 AND OTHERS.

NO CLAIM IS MADE TO THE EXCLUSIVE RIGHT TO USE "MANSION & CASINO", APART FROM THE MARK AS SHOWN.

THE NAME "JETHRO BODINE" DOES NOT IDENTIFY A LIVING INDIVIDUAL.

FOR RESTAURANT SERVICES (U.S. CLS. 100 AND 101).

MAUREEN DALL, EXAMINING ATTORNEY

CLASS 43—(Continued).

SN 85-191,810. RAIHANA HEUER, PADANG WESTERN SUMATRA, INDONESIA, FILED 12-7-2010.

KANDUI

THE MARK CONSISTS OF STANDARD CHARACTERS WITHOUT CLAIM TO ANY PARTICULAR FONT, STYLE, SIZE, OR COLOR.

FOR HEALTH RESORT SERVICES, NAMELY, PROVIDING FOOD AND LODGING THAT SPECIALIZE IN PROMOTING PATRONS' GENERAL HEALTH AND WELL-BEING; RESORT HOTELS; RESORT LODGING SERVICES (U.S. CLS. 100 AND 101).

WENDY GOODMAN, EXAMINING ATTORNEY

SN 85-195,321. CHEFS INTERNATIONAL, INC., POINT PLEASANT BEACH, NJ. FILED 12-10-2010.

**BAKER'S AMERICAN BAR &
GRILLE**

THE MARK CONSISTS OF STANDARD CHARACTERS WITHOUT CLAIM TO ANY PARTICULAR FONT, STYLE, SIZE, OR COLOR.

NO CLAIM IS MADE TO THE EXCLUSIVE RIGHT TO USE "AMERICAN BAR & GRILLE", APART FROM THE MARK AS SHOWN.

FOR BAR AND RESTAURANT SERVICES (U.S. CLS. 100 AND 101).

FIRST USE 7-20-2010; IN COMMERCE 7-20-2010.
DOMINICK J. SALEMI, EXAMINING ATTORNEY

SN 85-197,836. FOTM FRANCHISE, INC., PORTLAND, OR. FILED 12-14-2010.

**FIRE ON THE MOUNTAIN
BUFFALO WINGS**

THE MARK CONSISTS OF STANDARD CHARACTERS WITHOUT CLAIM TO ANY PARTICULAR FONT, STYLE, SIZE, OR COLOR.

NO CLAIM IS MADE TO THE EXCLUSIVE RIGHT TO USE "BUFFALO WINGS", APART FROM THE MARK AS SHOWN.

FOR RESTAURANT SERVICES FEATURING BUFFALO CHICKEN WINGS, BARBECUE SAUCES, CHICKEN SANDWICHES, CHICKEN SALADS (U.S. CLS. 100 AND 101).

FIRST USE 1-1-2005; IN COMMERCE 1-1-2005.
BENJAMIN OKEKE, EXAMINING ATTORNEY

CLASS 43—(Continued).

SN 85-208,671. RAIHANA HEUER, WESTERN SUMATRA, INDONESIA, FILED 12-31-2010.

KANDUI VILLAS

THE MARK CONSISTS OF STANDARD CHARACTERS WITHOUT CLAIM TO ANY PARTICULAR FONT, STYLE, SIZE, OR COLOR.

NO CLAIM IS MADE TO THE EXCLUSIVE RIGHT TO USE "VILLAS", APART FROM THE MARK AS SHOWN. FOR RESORT LODGING SERVICES (U.S. CLS. 100 AND 101).

FIRST USE 12-1-2010; IN COMMERCE 12-1-2010.
WENDY GOODMAN, EXAMINING ATTORNEY

SN 85-222,493. YELLOW HOUSE CAFE, INC., LOS ANGELES, CA. FILED 1-20-2011.

YELLOW HOUSE CAFE

THE MARK CONSISTS OF STANDARD CHARACTERS WITHOUT CLAIM TO ANY PARTICULAR FONT, STYLE, SIZE, OR COLOR.

NO CLAIM IS MADE TO THE EXCLUSIVE RIGHT TO USE "CAFE", APART FROM THE MARK AS SHOWN.

FOR CAFE AND RESTAURANT SERVICES; CAFE-RESTAURANTS (U.S. CLS. 100 AND 101).
TINA L. SNAPP, EXAMINING ATTORNEY

SN 85-234,482. QUE BUEN ROLLO, S.A. DE C.V., CANCUN, MEXICO, FILED 2-4-2011.



THE MARK CONSISTS OF THE WORD "MANYEE" WITH AN ACCENT OVER THE FIRST "E" FOLLOWED BY A CIRCULAR SPIRAL DESIGN WITH A FANCIFUL UNDERLINING ALL CONTAINED WITHIN AN OVAL.

THE WORDING "MANYEE" HAS NO MEANING IN A FOREIGN LANGUAGE.

FOR RESTAURANTS AND BARS (U.S. CLS. 100 AND 101).

WARREN L. OLANDRIA, EXAMINING ATTORNEY

CLASS 43—(Continued).

SN 85-236,691. BIG SAL'S, LLC, DALLAS, TX. FILED 2-8-2011.

BIG SAL'S

THE MARK CONSISTS OF STANDARD CHARACTERS WITHOUT CLAIM TO ANY PARTICULAR FONT, STYLE, SIZE, OR COLOR.

THE NAME(S), PORTRAIT(S), AND/OR SIGNATURE(S) SHOWN IN THE MARK DOES NOT IDENTIFY A PARTICULAR LIVING INDIVIDUAL.

FOR RESTAURANT SERVICES (U.S. CLS. 100 AND 101).

FIRST USE 8-6-2009; IN COMMERCE 8-6-2009.
DAVID HOFFMAN, EXAMINING ATTORNEY

SN 85-241,447. PAPPAS RESTAURANTS, INC., HOUSTON, TX. FILED 2-14-2011.

PAPPAS ICE HOUSE

THE MARK CONSISTS OF STANDARD CHARACTERS WITHOUT CLAIM TO ANY PARTICULAR FONT, STYLE, SIZE, OR COLOR.

OWNER OF U.S. REG. NOS. 1,378,547, 1,437,540 AND OTHERS.

FOR RESTAURANT AND BAR SERVICES (U.S. CLS. 100 AND 101).

INGRID C. EULIN, EXAMINING ATTORNEY

SN 85-242,378. CAJUN CRAWLERS, LLC, ST. SIMONS ISLAND, GA. FILED 2-15-2011.



NO CLAIM IS MADE TO THE EXCLUSIVE RIGHT TO USE "CAJUN", APART FROM THE MARK AS SHOWN.

THE MARK CONSISTS OF THE ARCHED WORD "CAJUN" APPEARING ON TOP OF A ROUND CITRUS FRUIT SLICE. A CRUSTACEAN IS PLACED OVER THE CITRUS FRUIT SLICE, AND UNDERNEATH THE CRUSTACEAN APPEARS THE WORD "CRAWLERS".

FOR CATERING SERVICES (U.S. CLS. 100 AND 101).
FIRST USE 4-30-2010; IN COMMERCE 5-14-2010.
JAY FLOWERS, EXAMINING ATTORNEY

CLASS 43—(Continued).

SN 85-242,394. CAJUN CRAWLERS, LLC, ST. SIMONS ISLAND, GA. FILED 2-15-2011.

CAJUN CRAWLERS

THE MARK CONSISTS OF STANDARD CHARACTERS WITHOUT CLAIM TO ANY PARTICULAR FONT, STYLE, SIZE, OR COLOR.

NO CLAIM IS MADE TO THE EXCLUSIVE RIGHT TO USE "CAJUN", APART FROM THE MARK AS SHOWN. FOR CATERING SERVICES (U.S. CLS. 100 AND 101). FIRST USE 4-30-2010; IN COMMERCE 5-14-2010. JAY FLOWERS, EXAMINING ATTORNEY

SN 85-245,360. BERNHARDT, MIKE, FAIRHOPE, AL. AND PULTITZER, MAC, FAIRHOPE, AL. FILED 2-17-2011.



NO CLAIM IS MADE TO THE EXCLUSIVE RIGHT TO USE "HOTEL", APART FROM THE MARK AS SHOWN.

THE MARK CONSISTS OF THE WORDING "PH" INSIDE A CIRCLE WITH A CURVED BAND CUTTING HORIZONTALLY THROUGH THE WORDING. CURVED BANDS WITH RIDGES APPEAR ON EACH SIDE OF THE CIRCLE. THE WORDING "THE PULTITZER" APPEARS BELOW THE WORDING WITH THE WORDING "HOTEL" APPEARING BELOW THE WORDING "THE PULTITZER". WAVY BANDS APPEAR ON EACH SIDE OF THE WORDING "HOTEL". THE WORDING AND THE DESIGN ELEMENTS APPEAR ON A SHADED BACKGROUND.

FOR HOTEL AND MOTEL SERVICES (U.S. CLS. 100 AND 101).

SETH A. RAPPAPORT, EXAMINING ATTORNEY

SN 85-250,938. MARRIOTT INTERNATIONAL, INC., BETHESDA, MD. FILED 2-24-2011.

COURTYARD REFRESHING SAVINGS

THE MARK CONSISTS OF STANDARD CHARACTERS WITHOUT CLAIM TO ANY PARTICULAR FONT, STYLE, SIZE, OR COLOR.

OWNER OF U.S. REG. NOS. 1,329,051, 3,643,532 AND OTHERS.

NO CLAIM IS MADE TO THE EXCLUSIVE RIGHT TO USE "SAVINGS", APART FROM THE MARK AS SHOWN.

FOR HOTEL, RESTAURANT, CATERING, BAR AND COCKTAIL LOUNGE SERVICES (U.S. CLS. 100 AND 101).

FIRST USE 1-14-2011; IN COMMERCE 1-14-2011.

GINA HAYES, EXAMINING ATTORNEY

CLASS 43—(Continued).

SN 85-252,494. DAO, DAT, HOUSTON, TX. FILED 2-26-2011.

WHATAPHO

THE MARK CONSISTS OF STANDARD CHARACTERS WITHOUT CLAIM TO ANY PARTICULAR FONT, STYLE, SIZE, OR COLOR.

FOR RESTAURANT SERVICES (U.S. CLS. 100 AND 101).

ESTHER A. BORSUK, EXAMINING ATTORNEY

SN 85-252,604. TOMPKINS, SAVANNAH, PARACHUTE, CO. FILED 2-26-2011.



NO CLAIM IS MADE TO THE EXCLUSIVE RIGHT TO USE "COFFEE", APART FROM THE MARK AS SHOWN.

THE COLOR(S) BROWN, LIGHT BROWN, GREEN, AND WHITE IS/ARE CLAIMED AS A FEATURE OF THE MARK.

THE MARK CONSISTS OF A BROWN CIRCLE WITH A GREEN OUTLINE. INSIDE THE BROWN CIRCLE IS A LIGHT BROWN CIRCLE CONTAINING A MOUNTAIN LANDSCAPE WITH TREES IN LIGHT BROWN, WHITE, BROWN AND GREEN. IN THE MIDDLE OF THE LANDSCAPE IS A HOUSE DRAWN TO HAVE ELEMENTS OF A COFFEE MUG IN GREEN, BROWN AND LIGHT BROWN. BELOW THE HOUSE APPEARS THE STYLIZED WORDS "MOUNTAIN GRIND COFFEE" IN WHITE ON A DARK BROWN BACKGROUND.

FOR COFFEE SHOPS (U.S. CLS. 100 AND 101).

ANNE MADDEN, EXAMINING ATTORNEY

CLASS 43—(Continued).

SN 85-253,583. 19 THINGS, LLC, SAN FRANCISCO, CA. FILED 2-28-2011.

CLASS 43—(Continued).

SN 85-257,326. PALENQUE LICENSING, LTD., LAREDO, TX. FILED 3-3-2011.



PALENQUE CHICKEN

NO CLAIM IS MADE TO THE EXCLUSIVE RIGHT TO USE "BAR" AND "CAFE & WINE BAR", APART FROM THE MARK AS SHOWN.

THE COLOR(S) BURGUNDY, BLACK AND GRAY IS/ ARE CLAIMED AS A FEATURE OF THE MARK.

THE MARK CONSISTS OF THE WORDS "BAR BAMBINO" IN ALL UPPER CASE LETTERS. THE LETTERS "BAR" ARE IN BLACK. THE LETTERS "BAMBINO" ARE IN BURGUNDY. BELOW THE WORDS "BAR BAMBINO" IN UPPER CASE IN A SMALLER FONT ARE THE WORDS "CAFE & WINE BAR" IN GRAY.

THE ENGLISH TRANSLATION OF "BAMBINO" IN THE MARK IS "BABY".

FOR CAFE AND WINE BAR (U.S. CLS. 100 AND 101). FIRST USE 10-1-2006; IN COMMERCE 4-1-2007. MARILYN IZZI, EXAMINING ATTORNEY

THE MARK CONSISTS OF STANDARD CHARACTERS WITHOUT CLAIM TO ANY PARTICULAR FONT, STYLE, SIZE, OR COLOR.

OWNER OF U.S. REG. NOS. 2,963,804, 3,685,097 AND 3,822,487.

NO CLAIM IS MADE TO THE EXCLUSIVE RIGHT TO USE "CHICKEN", APART FROM THE MARK AS SHOWN.

THE ENGLISH TRANSLATION OF THE WORD "PELANQUE" IN THE MARK IS PALING, ENCLOSURE OR ARENA. FOR RESTAURANT SERVICES (U.S. CLS. 100 AND 101).

FIRST USE 2-25-2011; IN COMMERCE 2-25-2011. VIVIAN MICZNIK FIRST, EXAMINING ATTORNEY

SN 85-254,365. BMC - THE BENCHMARK MANAGEMENT COMPANY, THE WOODLANDS, TX. FILED 3-1-2011.

SN 85-260,056. SAMBAZON, INC., SAN CLEMENTE, CA. FILED 3-7-2011.

PERSONAL LUXURY RESORT

SAMBAZON AÇAÍ CAFE

THE MARK CONSISTS OF STANDARD CHARACTERS WITHOUT CLAIM TO ANY PARTICULAR FONT, STYLE, SIZE, OR COLOR.

OWNER OF U.S. REG. NO. 3,024,853.

NO CLAIM IS MADE TO THE EXCLUSIVE RIGHT TO USE "LUXURY RESORT", APART FROM THE MARK AS SHOWN.

FOR PROVIDING TEMPORARY LODGING ACCOMMODATIONS; PROVIDING RESORT HOTEL SERVICES AND CONFERENCE CENTER SERVICES (U.S. CLS. 100 AND 101).

FIRST USE 1-24-2007; IN COMMERCE 1-24-2007. KEVON CHISOLM, EXAMINING ATTORNEY

THE MARK CONSISTS OF STANDARD CHARACTERS WITHOUT CLAIM TO ANY PARTICULAR FONT, STYLE, SIZE, OR COLOR.

OWNER OF U.S. REG. NOS. 2,841,851 AND 2,952,864.

NO CLAIM IS MADE TO THE EXCLUSIVE RIGHT TO USE "AÇAÍ CAFÉ", APART FROM THE MARK AS SHOWN. FOR CAFÉ, SNACK BAR AND SMOOTHIE BAR SERVICES (U.S. CLS. 100 AND 101).

FIRST USE 3-7-2011; IN COMMERCE 3-7-2011. LAURIE MAYES, EXAMINING ATTORNEY

CLASS 43—(Continued).

SN 85-260,144. CIMARRON STEAK HOUSES, INC., OKLAHOMA CITY, OK. FILED 3-7-2011.



THE MARK CONSISTS OF A DESIGN COMPRISED OF A STYLIZED MAN WITH A MUSTACHE AND BEARD, AND WEARING A COWBOY HAT, BANDANA AND BELT BUCKLE.
FOR RESTAURANT SERVICES (U.S. CLS. 100 AND 101).
RENEE MCCRAY, EXAMINING ATTORNEY

SN 85-262,744. MCDONOUGH, NANNETTE, SAN CLEMENTE, CA. AND MCDONOUGH, MICHAEL, SAN CLEMENTE, CA. FILED 3-9-2011.

MIKE'S ATTITUDE PIZZA

THE MARK CONSISTS OF STANDARD CHARACTERS WITHOUT CLAIM TO ANY PARTICULAR FONT, STYLE, SIZE, OR COLOR.
NO CLAIM IS MADE TO THE EXCLUSIVE RIGHT TO USE "PIZZA", APART FROM THE MARK AS SHOWN.
FOR PIZZA PARLORS (U.S. CLS. 100 AND 101).
ROBERT C. CLARK JR., EXAMINING ATTORNEY

SN 85-266,410. PECK, DEBORAH C., NORTH PALM BEACH, FL. FILED 3-14-2011.

Belle Mead

THE MARK CONSISTS OF STANDARD CHARACTERS WITHOUT CLAIM TO ANY PARTICULAR FONT, STYLE, SIZE, OR COLOR.
FOR PROVIDING ASSISTED LIVING FACILITIES (U.S. CLS. 100 AND 101).
FIRST USE 8-2-2010; IN COMMERCE 8-2-2010.
KATHRYN COWARD, EXAMINING ATTORNEY

CLASS 43—(Continued).

SN 85-267,038. BERKSHIRE INN, L.P., READING, PA. FILED 3-15-2011.



NO CLAIM IS MADE TO THE EXCLUSIVE RIGHT TO USE "PRIME STEAK & WINE", APART FROM THE MARK AS SHOWN.

THE COLOR(S) BLACK, BURGUNDY AND GRAY IS/ARE CLAIMED AS A FEATURE OF THE MARK.

THE MARK CONSISTS OF THE BLACK UNDERLINED LOWERCASE WORD "PRIME", WHERE THE "I" IS DEPICTED WITH A BURGUNDY COLORED WINE GLASS, WHICH APPEARS ABOVE THE GRAY UPPERCASE WORDS "STEAK & WINE," AND ALL APPEAR INSIDE A RECTANGLE OUTLINED IN BLACK.

FOR RESTAURANT AND BAR SERVICES (U.S. CLS. 100 AND 101).
CARYN GLASSER, EXAMINING ATTORNEY

SN 85-267,156. L & D DEVELOPMENT, CORTEZ, CO. FILED 3-15-2011.

J. fargo's

THE MARK CONSISTS OF STANDARD CHARACTERS WITHOUT CLAIM TO ANY PARTICULAR FONT, STYLE, SIZE, OR COLOR.

OWNER OF U.S. REG. NO. 2,914,824.

THE NAME "J. FARGO'S" DOES NOT IDENTIFY A LIVING INDIVIDUAL.

FOR BAR AND RESTAURANT SERVICES (U.S. CLS. 100 AND 101).

FIRST USE 10-20-2003; IN COMMERCE 10-20-2003.
DAVID COLLIER, EXAMINING ATTORNEY

SN 85-268,781. Q - DETROIT BARBEQUE, LLC, ROYAL OAK, MI. FILED 3-16-2011.

LOCKHART'S BBQ

THE MARK CONSISTS OF STANDARD CHARACTERS WITHOUT CLAIM TO ANY PARTICULAR FONT, STYLE, SIZE, OR COLOR.

NO CLAIM IS MADE TO THE EXCLUSIVE RIGHT TO USE "BBQ", APART FROM THE MARK AS SHOWN.

FOR RESTAURANT, BAR AND CATERING SERVICES (U.S. CLS. 100 AND 101).

FIRST USE 11-6-2008; IN COMMERCE 11-6-2008.
JAY FLOWERS, EXAMINING ATTORNEY

CLASS 43—(Continued).

SN 85-269,888. DON DAVIS STEAK & PASTA, INC., MIAMI, FL. FILED 3-17-2011.



NO CLAIM IS MADE TO THE EXCLUSIVE RIGHT TO USE "PARRILLADA RESTAURANT", APART FROM THE MARK AS SHOWN.

THE NAME "DON DAVIS" DOES NOT IDENTIFY A LIVING INDIVIDUAL.

THE MARK CONSISTS OF DEPICTION OF A MAN WITH A HAT AND SCARF, THE WORDS "DON DAVIS" ABOVE THE HAT, THE WORDS "PARRILLADA RESTAURANT" BELOW ON A BANNER.

THE ENGLISH TRANSLATION OF "DON" AND "PARRILLADA" IN THE MARK IS "MISTER" AND "GRILL".

FOR RESTAURANT SERVICES (U.S. CLS. 100 AND 101).

FIRST USE 12-1-2005; IN COMMERCE 12-1-2005.
CHERYL CLAYTON, EXAMINING ATTORNEY

SN 85-269,932. DON DAVIS STEAK & PASTA, INC., MIAMI, FL. FILED 3-17-2011.



NO CLAIM IS MADE TO THE EXCLUSIVE RIGHT TO USE "PARRILLADA RESTAURANT", APART FROM THE MARK AS SHOWN.

THE NAME "DONA PAULINA" DOES NOT IDENTIFY A LIVING INDIVIDUAL.

THE MARK CONSISTS OF DEPICTION OF A WOMAN WITH A HAT AND SCARF, THE WORDS "DONA PAULINA" ABOVE THE HAT, THE WORDS "PARRILLADA RESTAURANT" BELOW ON A BANNER.

THE ENGLISH TRANSLATION OF DOÑA AND PARRILLADA IN THE MARK IS "MISSES" AND "GRILL".

FOR RESTAURANT SERVICES (U.S. CLS. 100 AND 101).

FIRST USE 12-1-2009; IN COMMERCE 12-1-2009.
CHERYL CLAYTON, EXAMINING ATTORNEY

CLASS 43—(Continued).

SN 85-270,433. DALE'S RESTAURANTS, INC., BIRMINGHAM, AL. FILED 3-18-2011.



OWNER OF U.S. REG. NOS. 3,530,003, 3,589,771 AND OTHERS.

NO CLAIM IS MADE TO THE EXCLUSIVE RIGHT TO USE "RESTAURANT", APART FROM THE MARK AS SHOWN.

THE MARK CONSISTS OF THE WORDS "DALE'S RESTAURANT" WITH HORIZONTAL LINES BELOW THE WORD "DALE'S" AND BELOW THE WORD "RESTAURANT". THE WORD "DALE'S" IS IN A LOWER CASE STYLIZED FONT AND THE WORD "RESTAURANT" IS IN UPPER CASE BLOCK STYLE LETTERS. THERE IS A DRAWING OF A BULL TO THE LEFT OF THE WORDS THAT IS ANGLED UP AND FACING THE WORDS. THERE IS A DRAWING OF A BULL HEAD TO THE RIGHT OF THE WORDS THAT IS ANGLED UP AND FACING THE WORDS.

FOR RESTAURANT, CATERING, AND TAKE-OUT RESTAURANT SERVICES (U.S. CLS. 100 AND 101).

FIRST USE 12-1-1962; IN COMMERCE 12-1-1962.
DAVID COLLIER, EXAMINING ATTORNEY

SN 85-270,816. WASHINGTON STATE CONVENTION CENTER PUBLIC FACILITIES DISTRICT, DBA WASHINGTON STATE CONVENTION CENTER, SEATTLE, WA. FILED 3-18-2011.

Wild Rye Cafe Bakery

THE MARK CONSISTS OF STANDARD CHARACTERS WITHOUT CLAIM TO ANY PARTICULAR FONT, STYLE, SIZE, OR COLOR.

NO CLAIM IS MADE TO THE EXCLUSIVE RIGHT TO USE "CAFE BAKERY", APART FROM THE MARK AS SHOWN.

FOR RESTAURANT AND CAFE SERVICES (U.S. CLS. 100 AND 101).

MORGAN WYNNE, EXAMINING ATTORNEY

CLASS 43—(Continued).

SN 85-270,835. MAUI'S DOG HOUSE, INC., DBA MAUI'S DOG HOUSE, NORTH WILDWOOD, NJ. FILED 3-18-2011.



THE MARK CONSISTS OF CARICATURE OF A DOG, WEARING SUNGLASSES AND A BACKWARDS BASEBALL CAP, BALANCING A HOT DOG ON UPRAISED FINGER OF RIGHT PAW WHILE HOLDING A DOG BOWL FULL OF POTATO BALLS AND FRENCH FRIES IN THE OTHER PAW IN FRONT OF AN OVAL THAT CONTAINS A DRAWING OF AMUSEMENT PARK RIDES WITH FIREWORKS BURSTS ABOVE THE OVAL. ALL OF THE FOREGOING ITEMS ARE ABOVE THE WORDS "MAUI'S DOG HOUSE".

FOR RESTAURANT SERVICES, INCLUDING SIT-DOWN SERVICE OF FOOD AND TAKE-OUT RESTAURANT SERVICES (U.S. CLS. 100 AND 101).

FIRST USE 2-15-2011; IN COMMERCE 2-15-2011.

ANDREA BUTLER, EXAMINING ATTORNEY

SN 85-271,575. FAST DROP, INC, MITCHELL, IN. FILED 3-19-2011.



NO CLAIM IS MADE TO THE EXCLUSIVE RIGHT TO USE "VACATION PLANNER", APART FROM THE MARK AS SHOWN.

THE COLOR(S) YELLOW, BLACK, GREY AND RED IS/ ARE CLAIMED AS A FEATURE OF THE MARK.

THE MARK CONSISTS OF THE COLOR YELLOW WHICH APPEARS IN THE STARS SPUN FROM THE WAND IN THE SHAPE OF A "C". THE COLOR BLACK APPEARS IN THE WORDS "MAGICAL" AND "PLANNER". THE COLOR BLACK APPEARS OUTLINING THE YELLOW STAR ABOVE THE "I". THE COLOR RED APPEARS IN THE WORDS "VACATION". THE COLOR GREY APPEARS IN THE WAND ABOVE AND BELOW THE "I" IN "MAGICAL".

FOR PROVIDING TRAVEL LODGING INFORMATION SERVICES AND TRAVEL LODGING BOOKING AGENCY SERVICES FOR TRAVELERS (U.S. CLS. 100 AND 101).

FIRST USE 2-18-2008; IN COMMERCE 2-18-2008.

H. M. FISHER, EXAMINING ATTORNEY

CLASS 43—(Continued).

SN 85-272,408. LUCKYPIE MANAGEMENT CORPORATION, LOUISVILLE, CO. FILED 3-21-2011.

LUCKY PIE

THE MARK CONSISTS OF STANDARD CHARACTERS WITHOUT CLAIM TO ANY PARTICULAR FONT, STYLE, SIZE, OR COLOR.

NO CLAIM IS MADE TO THE EXCLUSIVE RIGHT TO USE "PIE", APART FROM THE MARK AS SHOWN.

FOR RESTAURANT SERVICES (U.S. CLS. 100 AND 101).

FIRST USE 8-1-2010; IN COMMERCE 8-1-2010.

TAMARA FRAZIER, EXAMINING ATTORNEY

SN 85-272,467. LUCKYPIE MANAGEMENT CORPORATION, LOUISVILLE, CO. FILED 3-21-2011.

LUCKY PIE PIZZA & TAP HOUSE

THE MARK CONSISTS OF STANDARD CHARACTERS WITHOUT CLAIM TO ANY PARTICULAR FONT, STYLE, SIZE, OR COLOR.

NO CLAIM IS MADE TO THE EXCLUSIVE RIGHT TO USE "PIE" OR "PIZZA & TAP HOUSE", APART FROM THE MARK AS SHOWN.

FOR RESTAURANT SERVICES (U.S. CLS. 100 AND 101).

FIRST USE 8-1-2010; IN COMMERCE 8-1-2010.

TAMARA FRAZIER, EXAMINING ATTORNEY

SN 85-272,924. LAURENT TOURONDEL, NEW YORK, NY. FILED 3-21-2011.

BLT AMERICAN BRASSERIE

THE MARK CONSISTS OF STANDARD CHARACTERS WITHOUT CLAIM TO ANY PARTICULAR FONT, STYLE, SIZE, OR COLOR.

OWNER OF U.S. REG. NOS. 3,049,597, 3,971,887 AND OTHERS.

NO CLAIM IS MADE TO THE EXCLUSIVE RIGHT TO USE "AMERICAN BRASSERIE", APART FROM THE MARK AS SHOWN.

FOR RESTAURANT SERVICES (U.S. CLS. 100 AND 101).

MARILYN IZZI, EXAMINING ATTORNEY

CLASS 43—(Continued).

SN 85-273,117. GARCES RESTAURANT GROUP, LLC, PHILADELPHIA, PA. FILED 3-22-2011.

GARCES TRADING CO.

THE MARK CONSISTS OF STANDARD CHARACTERS WITHOUT CLAIM TO ANY PARTICULAR FONT, STYLE, SIZE, OR COLOR.

FOR RESTAURANT AND BAR SERVICES; RESTAURANT SERVICES, NAMELY, PROVIDING OF FOOD AND BEVERAGES FOR CONSUMPTION ON AND OFF THE PREMISES (U.S. CLS. 100 AND 101).

FIRST USE 1-11-2010; IN COMMERCE 1-11-2010.
KATHERINE CONNOLLY, EXAMINING ATTORNEY

CLASS 43—(Continued).

SN 85-273,453. HECTOR SANZ, NEW YORK, NY. FILED 3-22-2011.

MELIBEA

THE MARK CONSISTS OF STANDARD CHARACTERS WITHOUT CLAIM TO ANY PARTICULAR FONT, STYLE, SIZE, OR COLOR.

FOR RESTAURANT SERVICES, INCLUDING SIT-DOWN SERVICE OF FOOD AND TAKE-OUT RESTAURANT SERVICES (U.S. CLS. 100 AND 101).

CHRISTINE COOPER, EXAMINING ATTORNEY

SN 85-273,894. Q - DETROIT BARBEQUE, LLC, ROYAL OAK, MI. FILED 3-22-2011.

SN 85-273,272. THE STATE OF CONNECTICUT, HARTFORD, CT. FILED 3-22-2011.



NO CLAIM IS MADE TO THE EXCLUSIVE RIGHT TO USE "FIELD", APART FROM THE MARK AS SHOWN.

THE NAME(S), PORTRAIT(S), AND/OR SIGNATURE(S) SHOWN IN THE MARK DOES NOT IDENTIFY A PARTICULAR LIVING INDIVIDUAL.

THE MARK CONSISTS OF THE OUTLINE OF THE FRONT OF A FOOTBALL STADIUM WITH THREE PENNANTS ABOVE IT. BELOW THE STADIUM IS THE WORD "RENTSCHLER" IN AN UPWARD CURVE UNDER WHICH IS THE WORD "FIELD".

FOR ARENA SERVICES, NAMELY, PROVIDING FACILITIES FOR SPORTS, CONCERTS, CONVENTIONS AND EXHIBITIONS; PROVIDING SOCIAL MEETING, BANQUET AND SOCIAL FUNCTION FACILITIES (U.S. CLS. 100 AND 101).

FIRST USE 4-10-2003; IN COMMERCE 4-10-2003.
JENNIFER MARTIN, EXAMINING ATTORNEY



NO CLAIM IS MADE TO THE EXCLUSIVE RIGHT TO USE "EST. 2010", "BBQ" AND "REAL BBQ", APART FROM THE MARK AS SHOWN.

THE COLOR(S) BLACK, RED AND WHITE IS/ARE CLAIMED AS A FEATURE OF THE MARK.

THE MARK CONSISTS OF THREE BLACK RINGS, WITH THE RING CLOSEST TO THE CENTER OF THE MARK CONTAINING "EST. 2010" IN WHITE LETTERS WITHIN THE TOP PORTION OF THE RING, AND THE WORDS "REAL BBQ" WITHIN THE BOTTOM PORTION OF THE RING, AND TWO WHITE RINGS ALTERNATE AFTER THE FIRST TWO BLACK RINGS TOWARDS THE CENTER OF THE MARK, WHICH IS A WHITE CIRCLE, AND THEN DIAGONALLY ACROSS THE CENTER OF THE ENTIRE MARK IS THE WORD "LOCKHART'S" IN A CURSIVE FONT WITH RED LETTERS, AND UNDER THAT WORD, COMPLETELY WITHIN IN THE WHITE CIRCLE IN THE CENTER OF THE MARK, IS THE WORD "BBQ" WITH RED LETTERS, AND THROUGHOUT THE ENTIRE MARK ARE WHITE CRACKS CREATING A WEATHERED APPEARANCE.

FOR RESTAURANT, BAR AND CATERING SERVICES (U.S. CLS. 100 AND 101).

FIRST USE 2-1-2010; IN COMMERCE 2-1-2010.
JAY FLOWERS, EXAMINING ATTORNEY

CLASS 43—(Continued).

SN 85-274,036. THE GREAT BAMBINO LLC, IDAHO FALLS, ID. FILED 3-22-2011.



NO CLAIM IS MADE TO THE EXCLUSIVE RIGHT TO USE "FRESH CASUAL ITALIAN", APART FROM THE MARK AS SHOWN.

THE MARK CONSISTS OF A RECTANGLE WITH A CIRCLE AND AN OUTLINE OF A TOMATO. INSIDE THERE IS THE STYLIZED TEXT "THE GREAT BAMBINO FRESH CASUAL ITALIAN".

FOR RESTAURANT SERVICES (U.S. CLS. 100 AND 101).

FIRST USE 1-1-2011; IN COMMERCE 1-12-2011.
JOSETTE BEVERLY, EXAMINING ATTORNEY

SN 85-274,831. BERGHOFF RESTAURANT COMPANY, BROOKFIELD, IL. FILED 3-23-2011.

BERGHOFF GARDENS

THE MARK CONSISTS OF STANDARD CHARACTERS WITHOUT CLAIM TO ANY PARTICULAR FONT, STYLE, SIZE, OR COLOR.

OWNER OF U.S. REG. NOS. 927,018, 3,806,319 AND OTHERS.

FOR RESTAURANT SERVICES (U.S. CLS. 100 AND 101).

CHRISTOPHER BUONGIORNO, EXAMINING ATTORNEY

SN 85-275,440. ICANDY, INC., CARSON CITY, NV. FILED 3-24-2011.

iCandy Burlesque Ultra Lounge

THE MARK CONSISTS OF STANDARD CHARACTERS WITHOUT CLAIM TO ANY PARTICULAR FONT, STYLE, SIZE, OR COLOR.

OWNER OF U.S. REG. NO. 3,407,811.

NO CLAIM IS MADE TO THE EXCLUSIVE RIGHT TO USE "BURLESQUE ULTRA LOUNGE", APART FROM THE MARK AS SHOWN.

FOR BAR AND COCKTAIL LOUNGE SERVICES (U.S. CLS. 100 AND 101).

DEIRDRE ROBERTSON, EXAMINING ATTORNEY

CLASS 43—(Continued).

SN 85-275,578. SEALAND GROUP, INC., DALLAS, TX. FILED 3-24-2011.



NO CLAIM IS MADE TO THE EXCLUSIVE RIGHT TO USE "BRAZIL", APART FROM THE MARK AS SHOWN.

THE COLOR(S) BLUE, BLACK AND WHITE IS/ARE CLAIMED AS A FEATURE OF THE MARK.

THE MARK CONSISTS OF THE WORDING "BAHIA DE BRAZIL", WITH THE WORDS "BAHIA" AND "BRAZIL" SHOWN IN BLUE, AND THE WORD "DE" SHOWN IN BLACK, WITH A BLACK AND WHITE SWORD SHOWN BELOW THE WORDING.

THE ENGLISH TRANSLATION OF "BAHIA DE BRAZIL" IN THE MARK IS "BAY OF BRAZIL".

FOR RESTAURANTS (U.S. CLS. 100 AND 101).
PAM WILLIS, EXAMINING ATTORNEY

SN 85-275,588. ZAFRA, JON, SACRAMENTO, CA. FILED 3-24-2011.



NO CLAIM IS MADE TO THE EXCLUSIVE RIGHT TO USE "CAFE", APART FROM THE MARK AS SHOWN.

THE COLOR(S) GREEN, YELLOW, AND BLACK IS/ARE CLAIMED AS A FEATURE OF THE MARK.

THE MARK CONSISTS OF A CIRCLE DESIGN APPEARING AS IF PAINTED, APPROXIMATELY HALF IN GREEN COLOR AND THE REMAINING PORTION IN YELLOW; THE WORD "BASICS" WRITTEN ACROSS THE CENTER OF THE DESIGN IN BLACK WITH A GREEN LEAF APPEARING INSTEAD OF THE DOT IN THE LETTER "I"; THE WORD "CAFE" IS WRITTEN IN BLACK UNDER THE WORD "BASICS". THE COLOR WHITE REPRESENTS BACKGROUND OR TRANSPARENT AREAS AND IS NOT PART OF THE MARK.

FOR BAR AND RESTAURANT SERVICES (U.S. CLS. 100 AND 101).

DEBRA LEE, EXAMINING ATTORNEY

CLASS 43—(Continued).

SN 85-275,921. BLOCHBERGER, CACILIA, VIENNA, AUSTRIA, FILED 3-24-2011.

JUICE BROTHERS

THE MARK CONSISTS OF STANDARD CHARACTERS WITHOUT CLAIM TO ANY PARTICULAR FONT, STYLE, SIZE, OR COLOR.

NO CLAIM IS MADE TO THE EXCLUSIVE RIGHT TO USE "JUICE", APART FROM THE MARK AS SHOWN.

FOR RESTAURANT SERVICES FOR PROVIDING FOOD AND DRINK (U.S. CLS. 100 AND 101).

JOHN SCHUYLER YARD, EXAMINING ATTORNEY

SN 85-276,778. VIKING RIVER CRUISES (BERMUDA) LTD., HAMILTON HM 11, BERMUDA, FILED 3-25-2011.

VIKING LONGSHIPS

THE MARK CONSISTS OF STANDARD CHARACTERS WITHOUT CLAIM TO ANY PARTICULAR FONT, STYLE, SIZE, OR COLOR.

OWNER OF U.S. REG. NOS. 2,796,425, 3,980,867 AND OTHERS.

FOR SERVICES FOR PROVIDING FOOD AND DRINK; TEMPORARY ACCOMMODATIONS; HOTEL SERVICES; RESTAURANT SERVICES; TRAVEL AGENCY SERVICES, NAMELY, MAKING RESERVATIONS AND BOOKINGS FOR HOTELS, RESTAURANTS AND TEMPORARY ACCOMMODATIONS; RESERVATION AND BOOKING SERVICES FOR OTHERS FOR HOTELS, RESTAURANTS AND TEMPORARY ACCOMMODATIONS; CONSULTANCY AND ADVISORY SERVICES RELATING TO ALL THE AFORESAID (U.S. CLS. 100 AND 101).

JOHN GARTNER, EXAMINING ATTORNEY

SN 85-276,939. MORELLI, DAVID E., CARDIFF, CA. FILED 3-25-2011.

CLANDESTINO

THE MARK CONSISTS OF STANDARD CHARACTERS WITHOUT CLAIM TO ANY PARTICULAR FONT, STYLE, SIZE, OR COLOR.

THE ENGLISH TRANSLATION OF "CLANDESTINO" IN THE MARK IS "CLANDESTINE".

FOR RESTAURANT; RESTAURANT AND BAR SERVICES (U.S. CLS. 100 AND 101).

SOPHIA S. KIM, EXAMINING ATTORNEY

CLASS 43—(Continued).

SN 85-277,091. HIBACHI DEVELOPMENT, LLC, ALBANY, GA. FILED 3-25-2011.



NO CLAIM IS MADE TO THE EXCLUSIVE RIGHT TO USE "HIBACHI", APART FROM THE MARK AS SHOWN.

THE NAME "HIBACHI JOE'S" DOES NOT IDENTIFY A LIVING INDIVIDUAL.

THE COLOR(S) RED, BLACK, TAN AND WHITE IS/ARE CLAIMED AS A FEATURE OF THE MARK.

THE MARK CONSISTS OF A TAN SUMO WRESTLER WEARING A RED, WHITE AND BLACK HAT AND TRUNKS AND STANDING ON A BLACK OVAL SURFACE. THE LITERAL ELEMENT "HIBACHI JOE'S" IN RED LETTERING BORDERED IN BLACK AND WHITE APPEARS TO THE RIGHT OF THE WRESTLER.

FOR RESTAURANT SERVICES, NAMELY, PROVIDING OF FOOD AND BEVERAGES FOR CONSUMPTION ON AND OFF THE PREMISES (U.S. CLS. 100 AND 101).

FIRST USE 3-1-2011; IN COMMERCE 3-1-2011.

CYNTHIA SLOAN, EXAMINING ATTORNEY

SN 85-277,980. SWICHES, BERLIN, CT. FILED 3-26-2011.



NO CLAIM IS MADE TO THE EXCLUSIVE RIGHT TO USE "SANDWICHES GRILLED SUBS PANINI SALADS", APART FROM THE MARK AS SHOWN.

THE MARK CONSISTS OF THE WORDING "SWICHES SANDWICHES GRILLED SUBS PANINI SALADS" DISPLAYED IN STYLIZED FONT WITH THE WORD "SWICHES" APPEARING IN LARGER FONT ABOVE THE WORDING "SANDWICHES GRILLED SUBS PANINI SALADS".

FOR FAST-FOOD RESTAURANTS FEATURING SANDWICHES (U.S. CLS. 100 AND 101).

FIRST USE 6-1-2010; IN COMMERCE 6-1-2010.

DAWN FELDMAN, EXAMINING ATTORNEY

CLASS 43—(Continued).

SN 85-279,651. WING IT UP, INC., SHREWSBURY, MA. FILED 3-29-2011.



NO CLAIM IS MADE TO THE EXCLUSIVE RIGHT TO USE "THE BEST", APART FROM THE MARK AS SHOWN. THE MARK CONSISTS OF A SMILING, MUSCULAR ROOSTER WITH THE WORDS "THE BEST" ON HIS LEFT WING, PEEKING OUT THROUGH AN OVAL WITH WING ELEMENTS ON EACH SIDE OF THE OVAL AND AN AMERICAN FLAG BACKGROUND INSIDE THE OVAL.

FOR RESTAURANT SERVICES (U.S. CLS. 100 AND 101).
FIRST USE 1-19-2011; IN COMMERCE 1-19-2011.
LINDSEY RUBIN, EXAMINING ATTORNEY

CLASS 43—(Continued).

SN 85-286,988. SMOKEYS, LLC, PALM BEACH GARDENS, FL. FILED 4-5-2011.

MRS. SMOKEYS REAL PIT BAR-B-Q

THE MARK CONSISTS OF STANDARD CHARACTERS WITHOUT CLAIM TO ANY PARTICULAR FONT, STYLE, SIZE, OR COLOR.

NO CLAIM IS MADE TO THE EXCLUSIVE RIGHT TO USE "REAL PIT BAR-B-Q", APART FROM THE MARK AS SHOWN.

FOR RESTAURANT AND CATERING SERVICES (U.S. CLS. 100 AND 101).
FIRST USE 3-1-1996; IN COMMERCE 3-1-1996.
EDWARD NELSON, EXAMINING ATTORNEY

SN 85-280,611. LOMATOS PIZZA LC, HAYS, KS. FILED 3-29-2011.



NO CLAIM IS MADE TO THE EXCLUSIVE RIGHT TO USE "PIZZA", APART FROM THE MARK AS SHOWN.

THE MARK CONSISTS OF THE STYLIZED WORDING "LOMATO'S PIZZA" APPEARING ON A DESIGN WITH A CIRCLE RESEMBLING A NEON SIGN.

FOR RESTAURANT SERVICES (U.S. CLS. 100 AND 101).
FIRST USE 8-1-1993; IN COMMERCE 8-1-1993.
NELSON SNYDER, EXAMINING ATTORNEY

SN 85-287,294. FRIJOLE LLC, DBA FRIJOLE MEXICAN GRILL, ROCHELLE PARK, NJ. FILED 4-6-2011.

FRIJOLE MEXICAN GRILL

THE MARK CONSISTS OF STANDARD CHARACTERS WITHOUT CLAIM TO ANY PARTICULAR FONT, STYLE, SIZE, OR COLOR.

NO CLAIM IS MADE TO THE EXCLUSIVE RIGHT TO USE "MEXICAN GRILL", APART FROM THE MARK AS SHOWN.

THE ENGLISH TRANSLATION OF THE WORD "FRIJOLE" IN THE MARK IS "ANY OF VARIOUS BEANS USED IN MEXICAN STYLE COOKING".

FOR RESTAURANT SERVICES; TAKE-OUT RESTAURANT SERVICES (U.S. CLS. 100 AND 101).
FIRST USE 10-1-2009; IN COMMERCE 4-26-2010.
LAURA KOVALSKY, EXAMINING ATTORNEY

SN 85-282,073. OTG EXPERIENCE, LLC, CHALFONT, PA. FILED 3-31-2011.

CABRILLO BURGER

THE MARK CONSISTS OF STANDARD CHARACTERS WITHOUT CLAIM TO ANY PARTICULAR FONT, STYLE, SIZE, OR COLOR.

NO CLAIM IS MADE TO THE EXCLUSIVE RIGHT TO USE "BURGER", APART FROM THE MARK AS SHOWN.

FOR RESTAURANT AND BAR SERVICES (U.S. CLS. 100 AND 101).
SANDRA BUJA, EXAMINING ATTORNEY

CLASS 43—(Continued).

SN 85-288,247. CUISINE FOR HEALING, INC, FT WORTH, TX. FILED 4-6-2011.

CUISINE for HEALING

THE MARK CONSISTS OF STANDARD CHARACTERS WITHOUT CLAIM TO ANY PARTICULAR FONT, STYLE, SIZE, OR COLOR.

OWNER OF U.S. REG. NO. 3,836,829.

NO CLAIM IS MADE TO THE EXCLUSIVE RIGHT TO USE "CUISINE", APART FROM THE MARK AS SHOWN.

FOR FOOD PREPARATION SERVICES FEATURING PREPARATION OF FOOD IN A RESTRICTED MANNER TO PROMOTE HEALTHIER LIFESTYLE (U.S. CLS. 100 AND 101).

FIRST USE 6-1-2008, THE MARK WAS FIRST USED ANYWHERE IN A DIFFERENT FORM OTHER THAN THAT SOUGHT TO BE REGISTERED AT LEAST AS EARLY AS 06/01/2008; IN COMMERCE 6-1-2008, THE MARK WAS FIRST USED IN COMMERCE IN A DIFFERENT FORM OTHER THAN THAT SOUGHT TO BE REGISTERED AT LEAST AS EARLY AS 06/01/2008.

TEJBIR SINGH, EXAMINING ATTORNEY

CLASS 43—(Continued).

SN 85-290,804. RETAIL RESTAURANT DEVELOPMENT, L.L.C., LAKEWOOD, WA. FILED 4-8-2011.



OWNER OF U.S. REG. NOS. 2,421,145 AND 2,650,147.

NO CLAIM IS MADE TO THE EXCLUSIVE RIGHT TO USE "SUSHI", APART FROM THE MARK AS SHOWN.

THE MARK CONSISTS OF AN UNFURLED JAPANESE-STYLE FOLDING FAN, OUTLINED WITH A THICK, BLACK BORDER. THE FAN CONTAINS TWELVE FOLDING PANELS. A BANNER CONTAINING THE WORDS "SUSHI KYO" IN LARGE BLOCK LETTERS IS CENTERED HORIZONTALLY ON THE FAN, EXTENDING FROM PANELS THREE TO TEN (COUNTING FROM LEFT TO RIGHT). "RRD'S" IS CENTERED OVER THE "SUSHI KYO" BANNER IN SMALLER BLOCK LETTERS, EXTENDING OVER FAN PANELS SIX TO SEVEN.

THE WORDING "KYO" HAS NO MEANING IN A FOREIGN LANGUAGE.

FOR CARRY-OUT RESTAURANTS; RESTAURANT AND CATERING SERVICES; RESTAURANT SERVICES; RESTAURANT SERVICES FEATURING SUSHI; RESTAURANTS; TAKE-OUT RESTAURANT SERVICES (U.S. CLS. 100 AND 101).

FIRST USE 8-15-2000; IN COMMERCE 8-15-2000.

KAREN BRACEY, EXAMINING ATTORNEY

SN 85-290,028. HYEKYUNG HWANG, LOS ANGELES, CA. FILED 4-8-2011.

BUL

THE MARK CONSISTS OF STANDARD CHARACTERS WITHOUT CLAIM TO ANY PARTICULAR FONT, STYLE, SIZE, OR COLOR.

FOR FOOD PREPARATION SERVICES (U.S. CLS. 100 AND 101).

LINDA M. KING, EXAMINING ATTORNEY

SN 85-291,160. VAQUERO STRATEGY, LLC, FORMERLY VAQUERO STRATEGY AND ENTERTAINMENT, LLC, SAN ANTONIO, TX. FILED 4-10-2011.



THE MARK CONSISTS OF THE LETTER "R", WITH THE MIRROR IMAGE OF THE LETTER "R" IMMEDIATELY TO ITS LEFT AND CONJOINED.

FOR BAR AND COCKTAIL LOUNGE SERVICES; BAR AND RESTAURANT SERVICES; BAR SERVICES; CAFE AND RESTAURANT SERVICES; PROVISION OF FOOD AND DRINK IN RESTAURANTS; RESTAURANT; RESTAURANT SERVICES (U.S. CLS. 100 AND 101).

GIANCARLO CASTRO, EXAMINING ATTORNEY

CLASS 43—(Continued).

SN 85-291,286. ENCHILADERIA, DBA BEE, DALLAS, TX. FILED 4-11-2011.

enchiladeria

THE MARK CONSISTS OF STANDARD CHARACTERS WITHOUT CLAIM TO ANY PARTICULAR FONT, STYLE, SIZE, OR COLOR.

FOR RESTAURANT SERVICES, NAMELY, PROVIDING OF FOOD AND BEVERAGES FOR CONSUMPTION ON AND OFF THE PREMISES (U.S. CLS. 100 AND 101).

FIRST USE 1-25-2011; IN COMMERCE 1-25-2011.
TIMOTHY FINNEGAN, EXAMINING ATTORNEY

CLASS 43—(Continued).

SN 85-291,741. TSALIANGOS, HRISTOS, JOLIET, IL. FILED 4-11-2011.



SN 85-291,623. BISTRO 24, LLC, DETROIT, MI. FILED 4-11-2011.

24GRILLE

THE MARK CONSISTS OF STANDARD CHARACTERS WITHOUT CLAIM TO ANY PARTICULAR FONT, STYLE, SIZE, OR COLOR.

FOR RESTAURANT AND BAR SERVICES (U.S. CLS. 100 AND 101).

FIRST USE 3-1-2009; IN COMMERCE 3-1-2009.
BRENDAN MCCAULEY, EXAMINING ATTORNEY

NO CLAIM IS MADE TO THE EXCLUSIVE RIGHT TO USE "CHICKEN", APART FROM THE MARK AS SHOWN.

THE COLOR(S) WHITE, RED, BROWN, BLACK AND YELLOW IS/ARE CLAIMED AS A FEATURE OF THE MARK.

THE MARK CONSISTS OF THE LITERAL ELEMENTS "THE CHUNKY CHICKEN" WHEREIN IT CONSISTS OF THE IMAGE OF A CHICKEN IN WHITE COLOR WITH ITS BEAK AND TOES ARE IN YELLOW COLOR AND ITS COMB IN RED COLOR, THE WORDS "THE CHUNKY" ARE WRITTEN ABOVE THE CHICKEN IMAGE AND THE WORD "CHICKEN" IS WRITTEN BELOW IT IN BLACK COLOR WITH BROWN SHADOW AS SHOWN IN THE MARK.

FOR RESTAURANT SERVICES (U.S. CLS. 100 AND 101).

LEIGH CAROLINE CASE, EXAMINING ATTORNEY

SN 85-291,722. TSALIANGOS, HRISTOS, JOLIET, IL. FILED 4-11-2011.

THE CHUNKY CHICKEN

THE MARK CONSISTS OF STANDARD CHARACTERS WITHOUT CLAIM TO ANY PARTICULAR FONT, STYLE, SIZE, OR COLOR.

NO CLAIM IS MADE TO THE EXCLUSIVE RIGHT TO USE "CHICKEN", APART FROM THE MARK AS SHOWN.

FOR RESTAURANT SERVICES (U.S. CLS. 100 AND 101).

LEIGH CAROLINE CASE, EXAMINING ATTORNEY

SN 85-292,453. CASELLULA, LLC, NEW YORK, NY. FILED 4-12-2011.

CASELLULA

THE MARK CONSISTS OF STANDARD CHARACTERS WITHOUT CLAIM TO ANY PARTICULAR FONT, STYLE, SIZE, OR COLOR.

FOR RESTAURANT AND WINE BAR SERVICES (U.S. CLS. 100 AND 101).

FIRST USE 5-0-2007; IN COMMERCE 5-0-2007.
GISELLE AGOSTO, EXAMINING ATTORNEY

CLASS 43—(Continued).

SN 85-292,610. EARHART, JESSICA, PITTSBURGH, PA.
FILED 4-12-2011.

Iron Betty

THE MARK CONSISTS OF STANDARD CHARACTERS
WITHOUT CLAIM TO ANY PARTICULAR FONT, STYLE,
SIZE, OR COLOR.

FOR RESTAURANT (U.S. CLS. 100 AND 101).
AMY HELLA, EXAMINING ATTORNEY

SN 85-292,962. OTG EXPERIENCE, LLC, CHALFONT, PA.
FILED 4-12-2011.

OTG Media Bar

THE MARK CONSISTS OF STANDARD CHARACTERS
WITHOUT CLAIM TO ANY PARTICULAR FONT, STYLE,
SIZE, OR COLOR.

OWNER OF U.S. REG. NOS. 2,908,809, 3,731,825 AND
OTHERS.

NO CLAIM IS MADE TO THE EXCLUSIVE RIGHT TO
USE "BAR", APART FROM THE MARK AS SHOWN.

FOR RESTAURANT AND BAR SERVICES (U.S. CLS.
100 AND 101).

SANDRA BUJA, EXAMINING ATTORNEY

SN 85-293,037. SBARRO, INC., MELVILLE, NY. FILED 4-12-
2011.



OWNER OF U.S. REG. NOS. 985,647, 1,834,998 AND
3,549,590.

NO CLAIM IS MADE TO THE EXCLUSIVE RIGHT TO
USE "FRESH ITALIAN COOKING", APART FROM THE
MARK AS SHOWN.

THE MARK CONSISTS OF THE PHRASE "FRESH ITA-
LIAN COOKING" BENEATH THE WORD "SBARRO". TO
THE LEFT OF THE LITERAL ELEMENTS ARE TWO
PARALLEL HORIZONTAL WAVY SOLID RECTANGLES.

FOR RESTAURANT SERVICES, INCLUDING SIT-
DOWN SERVICE OF FOOD AND TAKE-OUT RESTAU-
RANT SERVICES (U.S. CLS. 100 AND 101).

KEVIN DINALLO, EXAMINING ATTORNEY

CLASS 43—(Continued).

SN 85-293,490. EGGSPECTION RESTAURANTS, LLC,
TOWSON, MD. FILED 4-12-2011.

GRAB THE DAY BY THE EGGS

THE MARK CONSISTS OF STANDARD CHARACTERS
WITHOUT CLAIM TO ANY PARTICULAR FONT, STYLE,
SIZE, OR COLOR.

FOR CAFE, RESTAURANT, BAR AND TAKE-OUT
RESTAURANT SERVICES (U.S. CLS. 100 AND 101).

FIRST USE 3-0-2010; IN COMMERCE 3-0-2010.

JULIE WATSON, EXAMINING ATTORNEY

SN 85-294,081. ODEN, RACHEL, SHERMAN OAKS, CA.
FILED 4-13-2011.

FOODIIS

THE MARK CONSISTS OF STANDARD CHARACTERS
WITHOUT CLAIM TO ANY PARTICULAR FONT, STYLE,
SIZE, OR COLOR.

FOR RESTAURANT SERVICES (U.S. CLS. 100 AND
101).

JULIE WATSON, EXAMINING ATTORNEY

SN 85-294,186. PETER V SPAGNUOLO, WHITE PLAINS, NY.
FILED 4-13-2011.

ROUNDERS

THE MARK CONSISTS OF STANDARD CHARACTERS
WITHOUT CLAIM TO ANY PARTICULAR FONT, STYLE,
SIZE, OR COLOR.

FOR FAST-FOOD RESTAURANT SERVICES; RES-
TAURANT SERVICES (U.S. CLS. 100 AND 101).

DOMINICK J. SALEMI, EXAMINING ATTORNEY

CLASS 43—(Continued).

SN 85-294,656. SCINTO, ERNEST, TENAFLY, NJ. FILED 4-13-2011.

THE BACK FENCE

THE MARK CONSISTS OF STANDARD CHARACTERS WITHOUT CLAIM TO ANY PARTICULAR FONT, STYLE, SIZE, OR COLOR.

FOR BAR AND RESTAURANT SERVICES (U.S. CLS. 100 AND 101).

FIRST USE 1-1-1961; IN COMMERCE 1-1-1961.

SUSAN LESLIE DUBOIS, EXAMINING ATTORNEY

CLASS 43—(Continued).

SN 85-295,622. SMUSH LLC, HOBOKEN, NJ. FILED 4-14-2011.

Smush

THE MARK CONSISTS OF STANDARD CHARACTERS WITHOUT CLAIM TO ANY PARTICULAR FONT, STYLE, SIZE, OR COLOR.

FOR ICE CREAM SHOP SERVICES IN THE NATURE OF A RESTAURANT (U.S. CLS. 100 AND 101).

FIRST USE 3-17-2011; IN COMMERCE 3-17-2011.

WON TEAK OH, EXAMINING ATTORNEY

SN 85-295,225. THE THIRSTY SCHOLAR PUB, LLC, SOMERVILLE, MA. FILED 4-14-2011.

THIRSTY SCHOLAR

THE MARK CONSISTS OF STANDARD CHARACTERS WITHOUT CLAIM TO ANY PARTICULAR FONT, STYLE, SIZE, OR COLOR.

OWNER OF U.S. REG. NO. 2,295,692.
FOR RESTAURANT AND BAR SERVICES (U.S. CLS. 100 AND 101).

FIRST USE 12-3-1996; IN COMMERCE 12-1-1997.

ANNE MADDEN, EXAMINING ATTORNEY

SN 85-314,585. OTG EXPERIENCE, LLC, CHALFONT, PA. FILED 5-6-2011.

TWINBURGER

THE MARK CONSISTS OF STANDARD CHARACTERS WITHOUT CLAIM TO ANY PARTICULAR FONT, STYLE, SIZE, OR COLOR.

FOR BAR AND RESTAURANT SERVICES; RESTAURANT SERVICES (U.S. CLS. 100 AND 101).

SANDRA BUJA, EXAMINING ATTORNEY

SN 85-295,372. ICING SMILES, INC., ELLICOTT CITY, MD. FILED 4-14-2011.

ICING SMILES

THE MARK CONSISTS OF STANDARD CHARACTERS WITHOUT CLAIM TO ANY PARTICULAR FONT, STYLE, SIZE, OR COLOR.

FOR CHARITABLE SERVICES, NAMELY PROVIDING CAKES AND OTHER FOOD ITEMS TO FAMILIES IMPACTED BY CRITICAL ILLNESS OF A CHILD (U.S. CLS. 100 AND 101).

FIRST USE 11-1-2009; IN COMMERCE 11-1-2009.

TEJBIR SINGH, EXAMINING ATTORNEY

SN 85-344,661. BARILLA G. E R. FRATELLI - SOCIETÀ PER AZIONI, PARMA, ITALY, FILED 6-13-2011.

SPAGHETTATA

THE MARK CONSISTS OF STANDARD CHARACTERS WITHOUT CLAIM TO ANY PARTICULAR FONT, STYLE, SIZE, OR COLOR.

FOR PROVIDING AN INTERACTIVE WEBSITE IN THE FIELD OF FOOD RECIPES, FOOD PREPARATION TRENDS IN THE FOOD INDUSTRY, AND OTHER INFORMATION RELATING TO FOOD PREPARATION (U.S. CLS. 100 AND 101).

AISHA CLARKE, EXAMINING ATTORNEY

CLASS 43—(Continued).

SN 85-350,160. HO-CHUNK NATION, BLACK RIVER FALLS, WI. FILED 6-20-2011.



NO CLAIM IS MADE TO THE EXCLUSIVE RIGHT TO USE "RESORT CAMPING & RV PARK" AND "OWNED AND OPERATED BY", APART FROM THE MARK AS SHOWN.

THE COLOR(S) BLACK, GREEN, YELLOW, RED, BLUE, LIGHT BROWN, GRAY, WHITE, BROWN, AND DARK BROWN IS/ARE CLAIMED AS A FEATURE OF THE MARK.

THE MARK CONSISTS OF A CIRCLE OUTLINED IN BLACK AND GREEN CONTAINING A SCENE WITH A YELLOW AND RED SUNSET IN A BLUE SKY AND BLACK FOLIAGE IN THE DISTANCE, A LIGHT BROWN CABIN WITH BLACK DOOR AND WINDOW AND BLACK ACCENTS AND A LIGHT BROWN FENCE OVER A GREEN BACKGROUND, OVERLAID WITH A LIGHT BROWN RIFLE WITH YELLOW AND GRAY ACCENTS AND WHITE POWDER HORN WITH YELLOW AND BROWN ACCENTS HANGING FROM THE RIFLE ON A BROWN STRING, A DARK BROWN SIGN OVERLAID ACROSS THE CIRCLE CONTAINING THE WORD "CROCKETT'S" IN WHITE, A BLACK AND LIGHT BROWN COONSKIN CAP HANGING ON THE SIGN AND THE WORDS "RESORT CAMPING & RV PARK" AND "OWNED AND OPERATED BY THE HO-CHUNK NATION" ALL IN BLACK BELOW THE SIGN.

FOR PROVIDING CAMPGROUND FACILITIES; RESORT LODGING SERVICES (U.S. CLS. 100 AND 101).

FIRST USE 0-0-1997; IN COMMERCE 0-0-1997.

KATHLEEN M. VANSTON, EXAMINING ATTORNEY

CLASS 44—(Continued).

SN 77-687,725. BOWEN THERAPY CLINICS, CANADA LTD., STONEY CREEK, ONTARIO, CANADA, FILED 3-10-2009.

BOWEN 4 KIDS

THE MARK CONSISTS OF STANDARD CHARACTERS WITHOUT CLAIM TO ANY PARTICULAR FONT, STYLE, SIZE, OR COLOR.

OWNER OF CANADA REG. NO. TMA753814, DATED 11-24-2009, EXPIRES 11-24-2019.

NO CLAIM IS MADE TO THE EXCLUSIVE RIGHT TO USE "4 KIDS", APART FROM THE MARK AS SHOWN.

FOR MASSAGE THERAPY; MASSAGE THERAPY FOR HOMEBOUND OR UNDERPRIVILEGED CHILDREN; REMEDIAL THERAPIES, NAMELY, MASSAGE AND MESSAGE THERAPIES; HOMEOPATHIC AND NATUROPATHIC HEALTHCARE SERVICES; ALL THE FOREGOING BEING SPECIFIC TO THE PATIENT (U.S. CLS. 100 AND 101).

KATINA MISTER, EXAMINING ATTORNEY

SN 77-839,917. ATELLA, ANTHONY, WEST WARWICK, RI. FILED 10-2-2009.

CLASS 44—MEDICAL, BEAUTY AND AGRICULTURAL SERVICES

SN 76-704,255. HOW, DANA, VIRGINIA BEACH, VA. FILED 8-23-2010.

TRANS-CONSCIOUSNESS THERAPIES

NO CLAIM IS MADE TO THE EXCLUSIVE RIGHT TO USE "THERAPIES", APART FROM THE MARK AS SHOWN.

FOR PSYCHOTHERAPY SERVICES WHICH ADDRESS THE RELATIONSHIP OF ENERGY SYSTEMS TO COGNITION, EMOTION, BEHAVIOR AND HEALTH BY INTEGRATING CONTEMPORARY PSYCHOLOGY, ANCIENT HEALING TRADITIONS AND QUANTUM FIELDS IN ORDER TO ESTABLISH BALANCE AND HARMONY IN INDIVIDUALS (U.S. CLS. 100 AND 101).

FIRST USE 1-1-2009; IN COMMERCE 1-1-2009.

CAROLYN CATALDO, EXAMINING ATTORNEY

THE MARK CONSISTS OF STANDARD CHARACTERS WITHOUT CLAIM TO ANY PARTICULAR FONT, STYLE, SIZE, OR COLOR.

NO CLAIM IS MADE TO THE EXCLUSIVE RIGHT TO USE "TANS", APART FROM THE MARK AS SHOWN.

FOR TANNING SALONS (U.S. CLS. 100 AND 101).

ELLEN PERKINS, EXAMINING ATTORNEY

HOT TANS

CLASS 44—(Continued).

SN 79-082,643. WE, SOO-YOUNG, REPUBLIC OF KOREA, FILED 3-15-2010.



PRIORITY DATE OF 2-18-2010 IS CLAIMED.
OWNER OF INTERNATIONAL REGISTRATION 1038976
DATED 3-15-2010, EXPIRES 3-15-2020.

NO CLAIM IS MADE TO THE EXCLUSIVE RIGHT TO USE "BEAUTY", "GOLGEUN" AND THE NON-LATIN CHARACTERS THAT TRANSLITERATE TO "GOLGEUN", APART FROM THE MARK AS SHOWN.

THE COLOR(S) BRASS, ORANGE AND BLACK IS/ARE CLAIMED AS A FEATURE OF THE MARK.

THE MARK CONSISTS OF THE WORDS "GOLGEUN WE BEAUTY" AND FOREIGN CHARACTERS. THE FOREIGN CHARACTERS AND THE WORD "GOLGEUN" APPEAR INSIDE OF THE LETTER "W". THE LETTER "W" APPEARS IN BRASS, WHICH GRADUALLY DARKENS TO BLACK. THE WORD "BEAUTY" APPEARS IN ORANGE. THE REMAINDER OF THE MARKS ELEMENTS APPEAR IN BLACK.

THE ENGLISH TRANSLATION OF THE FOREIGN WORD(S) IN THE MARK IS: "BONE AND MUSCLE."

THE TRANSLITERATION OF THE NON-LATIN CHARACTERS IN THE MARK IS: "GOLGEUN".

FOR NAIL CARE SERVICES FEATURING NAIL ART; OPERATION OF PUBLIC BATHS FOR SANITARY PURPOSES; TATTOOING; BEAUTY CONSULTANCY; HAIRDRESSING SALONS; BEAUTY SALONS; PROVIDING INFORMATION ABOUT BEAUTY; FOOT MASSAGE; VISAGISTS' SERVICES, NAMELY, SERVICES OF MAKE-UP ARTIST; SAUNA SERVICES; MANICURING; HEALTH SPA SERVICES FOR HEALTH AND WELLNESS OF THE BODY AND SPIRIT, NAMELY, PROVIDING MASSAGE; RENTAL OF SANITATION FACILITIES; HAIRDRESSING AND BEAUTY SALONS; BARBER SHOP SERVICES; ARTIFICIAL SUNTANNING SERVICES; SOLARIUM SERVICES; PROVIDING PUBLIC BATH FACILITIES; PROVIDING TURKISH BATH FACILITIES; MASSAGE SERVICES; PHYSICAL THERAPY SERVICES, NAMELY, ACUPRESSURE THERAPY SERVICES; OPERATION OF SAUNA FACILITIES; HEALTH SPA SERVICES FOR HEALTH AND WELLNESS OF THE BODY AND SPIRIT; BEAUTY CONSULTATION SERVICES IN THE SELECTION AND USE OF COSMETICS; PROVIDING ON-SITE BEAUTY SERVICES, NAMELY, MAKE-UP APPLICATION SERVICES; COSMETIC SKIN CARE SERVICES (U.S. CLS. 100 AND 101).

ROBERT C. CLARK JR., EXAMINING ATTORNEY

CLASS 44—(Continued).

SN 85-034,843. YAGER, JEFFREY, NEW YORK, NY. FILED 5-10-2010.



NO CLAIM IS MADE TO THE EXCLUSIVE RIGHT TO USE "ESTHETICS ESTETICA", APART FROM THE MARK AS SHOWN.

THE COLOR(S) GRAY, GREEN, PINK, AND PURPLE IS/ARE CLAIMED AS A FEATURE OF THE MARK.

THE MARK CONSISTS OF AN ABSTRACT FLOWER DESIGN WITH GRAY, GREEN AND PINK PETALS, TO THE LEFT OF WHICH APPEARS THE WORDING "YAGER" IN GRAY LETTERING, AND BELOW WHICH APPEARS THE WORDING "ESTHETICS" IN PURPLE WORDING AND "ESTETICA" IN GRAY LETTERING.

THE ENGLISH TRANSLATION OF ESTETICA IN THE MARK IS "ESTHETICS".

FOR COSMETIC AND PLASTIC SURGERY (U.S. CLS. 100 AND 101).

FIRST USE 1-1-2010; IN COMMERCE 1-1-2010.

ERIN FALK, EXAMINING ATTORNEY

SN 85-053,155. FOSTER, BRIAN L., DBA INKAHOLICS TATTOO STUDIO, TUSTIN, CA. FILED 6-2-2010.



THE MARK CONSISTS OF THE WORD "INKAHOLICS.COM" IN STYLIZED FONT WRITTEN INSIDE THE OUTER EDGE OF A SOLID ARCH THAT SERVES AS A CARRIER. THE ARCH EXTENDS FROM THE LOWER LEFT TO THE UPPER RIGHT CORNER OF THE MARK, FORMING A QUARTER CIRCLE. INSIDE THE CARRIER IS A SILHOUETTE OF AN ELEPHANT.

FOR BODY PIERCING SERVICES; TATTOOING SERVICES (U.S. CLS. 100 AND 101).

FIRST USE 1-0-1997; IN COMMERCE 1-0-1997.

CARYN GLASSER, EXAMINING ATTORNEY

CLASS 44—(Continued).

SN 85-068,125. DYNAMIC BODY ART, DANIA, FL. FILED 6-21-2010.

Dynamic Body Art

THE MARK CONSISTS OF STANDARD CHARACTERS WITHOUT CLAIM TO ANY PARTICULAR FONT, STYLE, SIZE, OR COLOR.

NO CLAIM IS MADE TO THE EXCLUSIVE RIGHT TO USE "BODY ART", APART FROM THE MARK AS SHOWN.

FOR PROVIDING A WEBSITE PROVIDING INFORMATION ON WAYS FOR USERS TO ACHIEVE ENERGY AND CHAKRA ENHANCEMENT RELATING TO THE FIELDS OF ACUPUNCTURE, TATTOOING, AND BODY PIERCING (U.S. CLS. 100 AND 101).

FIRST USE 11-1-2009; IN COMMERCE 12-12-2009.
BARNEY CHARLON, EXAMINING ATTORNEY

SN 85-100,381. SANTIAGO, MARY T, PHILADELPHIA, PA. FILED 8-4-2010.

Barbers & Beauticians Union Local 215

THE MARK CONSISTS OF STANDARD CHARACTERS WITHOUT CLAIM TO ANY PARTICULAR FONT, STYLE, SIZE, OR COLOR.

NO CLAIM IS MADE TO THE EXCLUSIVE RIGHT TO USE "BARBERS & BEAUTICIANS", APART FROM THE MARK AS SHOWN.

FOR BARBER SHOP SERVICES; BEAUTY SALON SERVICES; HAIRCUTTING SERVICES; PROFESSIONAL IN HOUSE HAIR SERVICES TO PUBLIC AND PRIVATE FACILITIES NAMELY HAIR SALON SERVICES; BARBER SHOP SERVICES; BEAUTY SALON SERVICES (U.S. CLS. 100 AND 101).

ALICE BENMAMAN, EXAMINING ATTORNEY

SN 85-104,103. MEDAPPS, INC., SCOTTSDALE, AZ. FILED 8-10-2010.

Health Reader

THE MARK CONSISTS OF STANDARD CHARACTERS WITHOUT CLAIM TO ANY PARTICULAR FONT, STYLE, SIZE, OR COLOR.

NO CLAIM IS MADE TO THE EXCLUSIVE RIGHT TO USE "HEALTH", APART FROM THE MARK AS SHOWN.

FOR REMOTE MONITORING OF DATA INDICATIVE OF THE HEALTH OR CONDITION OF AN INDIVIDUAL OR GROUP OF INDIVIDUALS (U.S. CLS. 100 AND 101).

COLLEEN KEARNEY, EXAMINING ATTORNEY

CLASS 44—(Continued).

SN 85-109,467. LOBE, THOM, LOS ANGELES, CA. FILED 8-17-2010.

CLINICAL ALTERNATIVES

THE MARK CONSISTS OF STANDARD CHARACTERS WITHOUT CLAIM TO ANY PARTICULAR FONT, STYLE, SIZE, OR COLOR.

FOR MEDICAL SERVICES (U.S. CLS. 100 AND 101).
CAROLYN CATALDO, EXAMINING ATTORNEY

SN 85-112,754. LOBE, THOM, LOS ANGELES, CA. FILED 8-20-2010.

PHARMACEUTICAL ALTERNATIVES

THE MARK CONSISTS OF STANDARD CHARACTERS WITHOUT CLAIM TO ANY PARTICULAR FONT, STYLE, SIZE, OR COLOR.

FOR MEDICAL SERVICES (U.S. CLS. 100 AND 101).
CAROLYN CATALDO, EXAMINING ATTORNEY

SN 85-113,584. DARRYLL DEJUAN DAVIS, JACKSONVILLE, FL. FILED 8-23-2010.

MASSAGE-A-HOLICS

THE MARK CONSISTS OF STANDARD CHARACTERS WITHOUT CLAIM TO ANY PARTICULAR FONT, STYLE, SIZE, OR COLOR.

FOR HEALTH SPA SERVICES FOR HEALTH AND WELLNESS OF THE BODY AND SPIRIT, NAMELY, PROVIDING MASSAGE, FACIAL AND BODY TREATMENT SERVICES, COSMETIC BODY CARE SERVICES; MASSAGE; MASSAGE THERAPY SERVICES; MASSAGES (U.S. CLS. 100 AND 101).

FIRST USE 1-15-2009; IN COMMERCE 1-15-2009.
PAUL MORENO, EXAMINING ATTORNEY

CLASS 44—(Continued).

SN 85-113,966. VISITING NURSE ASSOCIATION OF CENTRAL JERSEY, RED BANK, NJ. FILED 8-23-2010.



OWNER OF U.S. REG. NO. 3,443,727.
NO CLAIM IS MADE TO THE EXCLUSIVE RIGHT TO USE "HEALTH GROUP", APART FROM THE MARK AS SHOWN.

THE COLOR(S) ORANGE, WHITE AND DARK GREY IS/ARE CLAIMED AS A FEATURE OF THE MARK.

THE MARK CONSISTS OF AN ORANGE CIRCLE CONTAINING THE LETTERS "VNA" IN WHITE LETTERS, WITH THE WORDS "HEALTH GROUP" IN DARK GREY LETTERS APPEARING TO THE RIGHT OF THE ORANGE CIRCLE.

FOR HOME HEALTH CARE SERVICES; HOSPICE CARE (U.S. CLS. 100 AND 101).

ARETHA SOMERVILLE, EXAMINING ATTORNEY

SN 85-115,795. SKIN PERFECT, LLC, WORTHINGTON, OH. FILED 8-25-2010.

mycolorcode

THE MARK CONSISTS OF STANDARD CHARACTERS WITHOUT CLAIM TO ANY PARTICULAR FONT, STYLE, SIZE, OR COLOR.

FOR COLOR ANALYSIS FOR COSMETIC PURPOSES (U.S. CLS. 100 AND 101).

BRIAN PINO, EXAMINING ATTORNEY

SN 85-123,288. WILLIAM A. PORTUESE, SEATTLE, WA. FILED 9-3-2010.

DR. NOSE KNOWS

THE MARK CONSISTS OF STANDARD CHARACTERS WITHOUT CLAIM TO ANY PARTICULAR FONT, STYLE, SIZE, OR COLOR.

FOR MEDICAL SERVICES (U.S. CLS. 100 AND 101).

FIRST USE 12-31-2007; IN COMMERCE 12-31-2007.

LEIGH CAROLINE CASE, EXAMINING ATTORNEY

CLASS 44—(Continued).

SN 85-124,758. FLAHARTY, PATRICK, FORT MYERS, FL. FILED 9-8-2010.



NO CLAIM IS MADE TO THE EXCLUSIVE RIGHT TO USE "FACES", APART FROM THE MARK AS SHOWN.

THE MARK CONSISTS OF AN OUTLINE OF A WOMAN'S FACE WITH THE STYLIZED TEXT "FACES BY FLAHARTY".

FOR FACIAL COSMETIC SURGERY, NAMELY, FACIAL REJUVENATION CONSISTING OF FACE/NECK LIFTS, BROW LIFTS, EYELID LIFTS, BOTOX, AND FILLERS (U.S. CLS. 100 AND 101).

WILLIAM P. SHANAHAN, EXAMINING ATTORNEY

SN 85-132,539. CHANTE SIMONE BUNTIN, DBA CHANTE SIMONE BUNTIN, MD, INC, APTOS, CA. FILED 9-17-2010.



NO CLAIM IS MADE TO THE EXCLUSIVE RIGHT TO USE "SYMPTOM MEDICINE", APART FROM THE MARK AS SHOWN.

THE COLOR(S) CRIMSON RED, YELLOW, BLACK AND WHITE IS/ARE CLAIMED AS A FEATURE OF THE MARK.

THE MARK CONSISTS OF THE LETTERS "SXM" IN BLACK FOLLOWED BY THE WORDS "SYMPTOM MEDICINE", PRINTED IN CRIMSON RED. TO THE LEFT OF THE WORDING APPEARS A DESIGN ELEMENT CONSISTING OF A SINGLE CRIMSON RED CIRCLE. THE INSIDE BORDER OF THE CIRCLE CONTAINS THE WORDING "SYMPTOM MEDICINE" IN WHITE ALONG THE TOP ARC OF THE CIRCLE. THE WORDS ARE PRECEDED AND FOLLOWED BY THE DESIGN OF A FLOWER IN YELLOW. THE WORDING "LIVE LIFE" ALSO APPEARS IN YELLOW AND IS SITUATED ALONG THE BOTTOM ARC OF THE CIRCLE. CENTERED IN THE MIDDLE OF THE CIRCLE, SITS A SYMMETRICAL THREE POINT TRIANGULAR SHAPED CREST FORMED BY SLIGHTLY CONVEX LINES. EMBEDDED WITHIN THE CREST IS A PATTERN OF INTERLOCKING "Y'S". THE COLOR OF THE "Y'S" ARE CRIMSON RED AND THE BACKGROUND COLOR OF THE CREST IS BLACK.

THE WORDING "SXM" HAS NO MEANING IN A FOREIGN LANGUAGE.

FOR MEDICAL SERVICES (U.S. CLS. 100 AND 101).

FIRST USE 7-1-2009; IN COMMERCE 9-1-2009.

ELLEN PERKINS, EXAMINING ATTORNEY

CLASS 44—(Continued).

SN 85-136,360. PURA VIDA PARTNERS, LLC, DENVER, CO. FILED 9-23-2010.

SPAVITAL

THE MARK CONSISTS OF STANDARD CHARACTERS WITHOUT CLAIM TO ANY PARTICULAR FONT, STYLE, SIZE, OR COLOR.

FOR DAY SPA SERVICES, NAMELY, COSMETIC BODY CARE SERVICES, MASSAGE; SALON SERVICES, NAMELY, MANICURES, PEDICURES, FACIALS, COSMETIC SKIN CARE, WAXING; ACUPUNCTURE; HOLISTIC NUTRITION COUNSELING; HEALTH SPA SERVICES, NAMELY, PROVIDING STEAM ROOM AND WHIRL POOL FACILITIES (U.S. CLS. 100 AND 101).

STEVEN PEREZ, EXAMINING ATTORNEY

CLASS 44—(Continued).

SN 85-145,847. TOP MODELS SALON & BOUTIQUE LLC, BLOOMFIELD HILLS, MI. FILED 10-5-2010.

TOP MODELS

THE MARK CONSISTS OF STANDARD CHARACTERS WITHOUT CLAIM TO ANY PARTICULAR FONT, STYLE, SIZE, OR COLOR.

FOR SALON AND SPA SERVICES, NAMELY, HAIR CUTTING, STYLING, COLORING, AND HAIR EXTENSION SERVICES, MANICURES, PEDICURES, PROVIDING MASSAGE, FACIAL AND BODY TREATMENT SERVICES, COSMETIC BODY CARE SERVICES (U.S. CLS. 100 AND 101).

KIM MONINGHOFF, EXAMINING ATTORNEY

SN 85-140,462. GARDEN STATE ORAL & MAXILLOFACIAL SURGERY, LLC, ELMWOOD PARK, NJ. FILED 9-28-2010.



NO CLAIM IS MADE TO THE EXCLUSIVE RIGHT TO USE "ORAL & MAXILLOFACIAL SURGERY", APART FROM THE MARK AS SHOWN.

THE MARK CONSISTS OF A GREEN SYMBOL OF THE STATE OF NEW JERSEY WITH SEVERAL DIAGONAL LINES RUNNING FROM NORTHWEST TO SOUTHEAST, CREATING SEVERAL CROSS-SECTIONS WHICH TOGETHER APPEAR TO FORM THE STATE OF NEW JERSEY. TWO GREEN VERTICAL LINES SEPARATE THE SYMBOL FROM THE GREEN WORDING "GARDEN STATE ORAL & MAXILLOFACIAL SURGERY" WHICH APPEARS TO THE RIGHT.

SEC. 2(F).

FOR ORAL SURGERY AND DENTAL IMPLANT SERVICES (U.S. CLS. 100 AND 101).

FIRST USE 12-27-2000; IN COMMERCE 12-27-2000.

VIVIAN MICZNIK FIRST, EXAMINING ATTORNEY

SN 85-162,351. ALL CARE EYE CLINIC, PA, DALLAS, TX. FILED 10-27-2010.



NO CLAIM IS MADE TO THE EXCLUSIVE RIGHT TO USE "CARE EYE CLINIC", APART FROM THE MARK AS SHOWN.

THE COLOR(S) BLUE AND GREY IS/ARE CLAIMED AS A FEATURE OF THE MARK.

THE MARK CONSISTS OF THE WORDS "ALL CARE" APPEARING ON THE TOP LINE IN ALL CAPITALIZED GREY LETTERS, WITH THE WORD "EYE" APPEARING IMMEDIATELY BELOW IN LARGER CAPITALIZED BLUE LETTERS HAVING A BLUE CIRCLE AROUND LETTER "E", AND THE WORD "CLINIC" APPEARING ON THE BOTTOM LINE IN ALL CAPITALIZED GREY LETTERS.

FOR OPTOMETRY SERVICES (U.S. CLS. 100 AND 101).
BERYL GARDNER, EXAMINING ATTORNEY

CLASS 44—(Continued).

SN 85-172,169. DR. G'S FRANCHISING COMPANIES, LLC., DAVIE, FL. AND JDJ OF MIAMI, INC., AVENTURA, FL. FILED 11-9-2010.



NO CLAIM IS MADE TO THE EXCLUSIVE RIGHT TO USE "WEIGHT LOSS & WELLNESS", APART FROM THE MARK AS SHOWN.

THE NAME(S), PORTRAIT(S), AND/OR SIGNATURE(S) SHOWN IN THE MARK IDENTIFIES THE NICKNAME OF CHARLES L. GOLDSMITH, A LIVING INDIVIDUAL, WHOSE CONSENT(S) TO REGISTER IS MADE OF RECORD.

THE COLOR(S) BLACK AND PURPLE IS/ARE CLAIMED AS A FEATURE OF THE MARK.

THE MARK CONSISTS OF THE STYLIZED WORDING "DR. G'S WEIGHTLOSS & WELLNESS". THE "G" IN "G'S" IS PURPLE. THE REMAINDER OF THE LETTERING IS BLACK. A BLACK, SINGLE LINE RECTANGLE OUTLINES THE WORDING. THE WHITE REPRESENTS BACKGROUND AND IS NOT PART OF THE MARK.

FOR MEDICAL CLINICS FEATURING WEIGHT LOSS SOLUTIONS, SERVICES AND PROGRAMS (U.S. CLS. 100 AND 101).

KIM SAITO, EXAMINING ATTORNEY

SN 85-200,379. THE CHRISTIAN AND MISSIONARY ALLIANCE FOUNDATION, INC., FORT MYERS, FL. FILED 12-17-2010.



NO CLAIM IS MADE TO THE EXCLUSIVE RIGHT TO USE "HEALTH SYSTEM", APART FROM THE MARK AS SHOWN.

THE COLOR(S) BLUE AND WHITE IS/ARE CLAIMED AS A FEATURE OF THE MARK.

THE MARK CONSISTS OF THE STYLIZED WORDING "SHELL POINT HEALTH SYSTEM" IN A RECTANGULAR BOX. THE LEFT SIDE OF THE RECTANGLE IS WHITE AND OUTLINED IN BLUE AND CONTAINS THE WORDING "SHELL POINT" IN BLUE. THE RIGHT SIDE OF THE RECTANGLE IS BLUE AND CONTAINS THE WORDING "HEALTH SYSTEM" IN WHITE.

FOR HEALTH CARE SERVICES, NAMELY, PROVIDING SENIORS WITH NURSING CARE, MEMORY LOSS CARE, MEDICAL SERVICES, PHYSICAL REHABILITATION AND PHYSICAL THERAPY SERVICES, OCCUPATIONAL THERAPY SERVICES, AND HOSPICE CARE (U.S. CLS. 100 AND 101).

FIRST USE 1-1-2010; IN COMMERCE 1-1-2010.
BARBARA GAYNOR, EXAMINING ATTORNEY

CLASS 44—(Continued).

SN 85-206,183. LESSER, MICHAEL F, MELBOURNE BEACH, FL. FILED 12-27-2010.



NO CLAIM IS MADE TO THE EXCLUSIVE RIGHT TO USE "SCULPTURE", APART FROM THE MARK AS SHOWN.

THE COLOR(S) LIGHT GREEN, LIGHT BLUE AND GRAY IS/ARE CLAIMED AS A FEATURE OF THE MARK.

THE MARK CONSISTS OF THE WORDS "SOFT SCULPTURE" IN GRAY WITH A LIGHT GREEN WAVY LINE IN THE CENTER OF THE LETTER "O" AND TWO LIGHT BLUE WAVY LINES ON EITHER SIDE OF THE LIGHT GREEN LINE.

FOR MEDICAL SERVICES, NAMELY, PROVIDING INJECTION TREATMENTS USING BOTULISM TOXIN AND OTHER DERMAL FILLERS FOR THE TREATMENT OF WRINKLES (U.S. CLS. 100 AND 101).

FIRST USE 11-30-2010; IN COMMERCE 12-27-2010.
JOHN WILKE, EXAMINING ATTORNEY

SN 85-214,647. NORTHEAST ARC, INC., DANVERS, MA. FILED 1-11-2011.

SPOTLIGHT

THE MARK CONSISTS OF STANDARD CHARACTERS WITHOUT CLAIM TO ANY PARTICULAR FONT, STYLE, SIZE, OR COLOR.

FOR DRAMA-BASED THERAPEUTIC PROGRAMS FOR STUDENTS WITH SOCIAL AND EMOTIONAL DISABILITIES FOR SOCIAL ASSIMILATION PURPOSES (U.S. CLS. 100 AND 101).

FIRST USE 6-1-2004; IN COMMERCE 4-6-2010.
BARBARA RUTLAND, EXAMINING ATTORNEY

CLASS 44—(Continued).

SN 85-227,680. 2 J-A 1476 S.L., ASPE, SPAIN, FILED 1-27-2011.

Vellisimo Center

THE MARK CONSISTS OF STANDARD CHARACTERS WITHOUT CLAIM TO ANY PARTICULAR FONT, STYLE, SIZE, OR COLOR.

NO CLAIM IS MADE TO THE EXCLUSIVE RIGHT TO USE "CENTER", APART FROM THE MARK AS SHOWN.

THE WORDING "VELLISIMO" HAS NO MEANING IN A FOREIGN LANGUAGE.

FOR HEALTH AND BEAUTY CARE SERVICES FOR PEOPLE, NAMELY, THE REMOVAL OF ALL TYPES OF UNWANTED BODY AND FACIAL HAIR (U.S. CLS. 100 AND 101).

ANDREW LEASER, EXAMINING ATTORNEY

SN 85-236,586. TEXAS ORTHOPAEDIC ASSOCIATES, L.L.P., DALLAS, TX. FILED 2-8-2011.



THE MARK CONSISTS OF AN IMAGE OF THE STATE OF "TEXAS" ENCLOSED A SILHOUETTE OF A MALE FIGURE RUNNING.

FOR SURGICAL SERVICES, NAMELY, ORTHOPAEDIC SURGERY; MEDICAL SERVICES, NAMELY, GENERAL ORTHOPEDICS, TREATMENT OF SPINAL INJURIES AND DISORDERS, AND TREATMENT OF SPORTS-RELATED INJURIES AND DISORDERS (U.S. CLS. 100 AND 101).

FIRST USE 9-0-1994; IN COMMERCE 9-0-1994.
MARLENE BELL, EXAMINING ATTORNEY

CLASS 44—(Continued).

SN 85-237,653. AKSM MEDICAL VENTURES, INC., COLUMBUS, OH. FILED 2-9-2011.



NO CLAIM IS MADE TO THE EXCLUSIVE RIGHT TO USE "SPECIALISTS OF AMERICA" AND "USA", APART FROM THE MARK AS SHOWN.

THE MARK CONSISTS OF THE WORDING "UNITED SPECIALISTS ABOVE THE WORDING "OF AMERICA", WITH A HORIZONTAL LINE APPEARING ABOVE THE WORDING AND A SHORTER HORIZONTAL LINE APPEARING BELOW THE WORDING. A DESIGN ELEMENT CONSISTING OF A STYLIZED STETHOSCOPE APPEARS TO THE RIGHT OF THE WORD "AMERICA", WITH THE STETHOSCOPE EARPIECES FORMING THE LETTER "U" IN "USA".

FOR PROFESSIONAL MEDICAL SERVICES (U.S. CLS. 100 AND 101).

KAREN SEVERSON, EXAMINING ATTORNEY

SN 85-246,530. FOOD THERAPY, L.L.C., LAFAYETTE, LA. FILED 2-18-2011.

FOODSPIRATION

THE MARK CONSISTS OF STANDARD CHARACTERS WITHOUT CLAIM TO ANY PARTICULAR FONT, STYLE, SIZE, OR COLOR.

FOR PROVIDING INFORMATION IN THE FIELD OF NUTRITION (U.S. CLS. 100 AND 101).

FIRST USE 5-1-2009; IN COMMERCE 5-1-2009.

CAROLYN CATALDO, EXAMINING ATTORNEY

SN 85-249,031. LOVE OVER LOGIC, LLC, MABLETON, GA. FILED 2-23-2011.

Love Over Logic

THE MARK CONSISTS OF STANDARD CHARACTERS WITHOUT CLAIM TO ANY PARTICULAR FONT, STYLE, SIZE, OR COLOR.

FOR CONSULTATION SERVICES IN THE FIELD OF MAKEUP, NAMELY, ON-LINE MAKEUP CONSULTATION SERVICES AND IN-PERSON MAKEUP CONSULTATION AND APPLICATION SERVICES (U.S. CLS. 100 AND 101).

FIRST USE 6-29-2010; IN COMMERCE 8-16-2010.
MARY BOAGNI, EXAMINING ATTORNEY

CLASS 44—(Continued).

SN 85-249,795. ASSOCIATES IN GASTROENTEROLOGY, P.C., WOODBRIDGE, VA. FILED 2-23-2011.



NO CLAIM IS MADE TO THE EXCLUSIVE RIGHT TO USE "GASTROENTEROLOGY", APART FROM THE MARK AS SHOWN.

THE COLOR(S) GREEN AND BLACK IS/ARE CLAIMED AS A FEATURE OF THE MARK.

THE MARK CONSISTS OF THE STYLIZED LETTERS "AG" IN GREEN WITH THE STYLIZED WORDS "ASSOCIATES IN GASTROENTEROLOGY" IN BLACK.

FOR MEDICAL SERVICES (U.S. CLS. 100 AND 101).

FIRST USE 1-0-2011; IN COMMERCE 1-0-2011.
SHAILA SETTLES, EXAMINING ATTORNEY

SN 85-254,248. WILDLIFE IN CRISIS, INC., WESTON, CT. FILED 3-1-2011.

WILDLIFE IN CRISIS

THE MARK CONSISTS OF STANDARD CHARACTERS WITHOUT CLAIM TO ANY PARTICULAR FONT, STYLE, SIZE, OR COLOR.

NO CLAIM IS MADE TO THE EXCLUSIVE RIGHT TO USE "WILDLIFE", APART FROM THE MARK AS SHOWN.

FOR WILDLIFE PRESERVATION, NAMELY, VETERINARY SERVICES AND REHABILITATION PATIENT CARE SERVICES FOR WILD ANIMALS (U.S. CLS. 100 AND 101).

FIRST USE 11-8-1989; IN COMMERCE 11-8-1989.
KATHY DE JONGE, EXAMINING ATTORNEY

SN 85-254,877. WILDLIFE IN CRISIS, INC., WESTON, CT. FILED 3-1-2011.

THE WILDLIFE CENTER

THE MARK CONSISTS OF STANDARD CHARACTERS WITHOUT CLAIM TO ANY PARTICULAR FONT, STYLE, SIZE, OR COLOR.

SEC. 2(F).

FOR WILDLIFE PRESERVATION, NAMELY, VETERINARY SERVICES AND REHABILITATION PATIENT CARE SERVICES FOR WILD ANIMALS (U.S. CLS. 100 AND 101).

FIRST USE 11-8-1989; IN COMMERCE 11-8-1989.
KATHY DE JONGE, EXAMINING ATTORNEY

CLASS 44—(Continued).

SN 85-255,481. WILDLIFE IN CRISIS, INC., WESTON, CT. FILED 3-2-2011.



THE MARK CONSISTS OF A FEATHER, A LEAF AND AN ANIMAL FOOTPRINT ARRANGED IN A CIRCLE.

FOR WILDLIFE PRESERVATION, NAMELY, VETERINARY SERVICES AND REHABILITATION PATIENT CARE SERVICES FOR WILD ANIMALS (U.S. CLS. 100 AND 101).

FIRST USE 11-8-1989; IN COMMERCE 11-8-1989.
KATHY DE JONGE, EXAMINING ATTORNEY

SN 85-257,551. BLUE COLLAR MUTINY, DBA THE REBELLION, DENVER, CO. FILED 3-3-2011.



THE MARK CONSISTS OF THE WORDING "THE" IN ALL CAPITAL LETTERS RESTING INSIDE A SEMI-CIRCLE ON TOP OF A CUSTOM-DRAWN, STYLIZED VERSION OF THE WORDING "REBELLION" IN WHICH THE LETTER "R" IS CAPITALIZED AND THE "EBELLION" PORTION IS IN LOWER-CASE LETTERS. A FILIGREE DESIGN SURROUNDS THE TOP AND BOTTOM OF THE WORDING "REBELLION".

FOR TATTOO STUDIOS (U.S. CLS. 100 AND 101).
FIRST USE 8-15-2008; IN COMMERCE 8-15-2008.
HAI-LY LAM, EXAMINING ATTORNEY

CLASS 44—(Continued).

SN 85-259,877. DR. VAN HERLE, KATJA, SAN DIEGO, CA. FILED 3-7-2011.



NO CLAIM IS MADE TO THE EXCLUSIVE RIGHT TO USE "HEART DISEASE,DIABETES" OR "7 QUESTIONS TO ASK YOUR DOCTOR", APART FROM THE MARK AS SHOWN.

THE NAME(S), PORTRAIT(S), AND/OR SIGNATURE(S) SHOWN IN THE MARK IDENTIFIES DR. KATJA VAN HERLE, WHOSE CONSENT(S) TO REGISTER IS MADE OF RECORD.

THE COLOR(S) GRAY, BLUE, AND BLACK IS/ARE CLAIMED AS A FEATURE OF THE MARK.

THE MARK CONSISTS OF A RECTANGULAR BOX SHAPE BY GRAY BORDERLINE, CONTAINING THE WORDING "DR V'S" IN THE COLOR GRAY AND SITUATED DIRECTLY ABOVE THE WORD "TOP" WHICH IS IN BLACK. TO THE RIGHT OF BOTH LINES IS A LARGER FONT OF NUMBER "7" IN BLUE. DIRECTLY BELOW THE GRAY RECTANGULAR BOX ARE TWO WORDS: "HEART DISEASE", AND "DIABETES" IN GRAY; WITH A PERIOD IN GRAY SEPARATES THEM. AT THE BOTTOM IS THE PHRASE "QUESTIONS TO ASK YOUR DOCTOR" IN LARGER FONT AND IN THE COLOR BLUE.

FOR PROVIDING INFORMATION IN THE FIELD OF DIABETES; PROVIDING MEDICAL INFORMATION, CONSULTANCY AND ADVISORY SERVICES (U.S. CLS. 100 AND 101).

FIRST USE 10-1-2010; IN COMMERCE 10-1-2010.
MORGAN WYNNE, EXAMINING ATTORNEY

SN 85-261,722. AVERUS MEDICAL GROUP LLC, DBA SUNRIDGE MEDICAL, SCOTTSDALE, AZ. FILED 3-9-2011.

SUNRIDGE MEDICAL

THE MARK CONSISTS OF STANDARD CHARACTERS WITHOUT CLAIM TO ANY PARTICULAR FONT, STYLE, SIZE, OR COLOR.

NO CLAIM IS MADE TO THE EXCLUSIVE RIGHT TO USE "MEDICAL", APART FROM THE MARK AS SHOWN.

FOR HEALTHCARE, ALTERNATIVE MEDICINE SERVICES; MEDICAL CLINIC PROVIDING WEIGHT LOSS SOLUTION; WELLNESS AND HEALTH-RELATED CONSULTING SERVICES (U.S. CLS. 100 AND 101).

FIRST USE 11-1-2006; IN COMMERCE 11-1-2006.
KATHY DE JONGE, EXAMINING ATTORNEY

CLASS 44—(Continued).

SN 85-265,028. NOWARY NRI, COLUMBUS, OH. FILED 3-11-2011.

Life So Much Better

THE MARK CONSISTS OF STANDARD CHARACTERS WITHOUT CLAIM TO ANY PARTICULAR FONT, STYLE, SIZE, OR COLOR.

FOR CONDUCTING TELEPHONE AND IN-PERSON PERSONAL LIFESTYLE WELLNESS ASSESSMENTS; CONSULTING IN THE FIELD OF HEALTH AND WELLNESS TO BRING ABOUT PERSONAL HAPPINESS; CONSULTING SERVICES IN THE FIELD OF MENTAL HEALTH AND WELLNESS; CONSULTING SERVICES TO HEALTH CARE PROVIDERS IN THE FIELD OF TREATING LIFE-CHANGING OR LIFE-THREATENING DISEASES; COUNSELING SERVICES IN THE FIELDS OF HEALTH, HERBALISM, AND LIFESTYLE WELLNESS; COUNSELING SERVICES IN THE FIELDS OF HEALTH, NUTRITION AND LIFESTYLE WELLNESS; HEALTH ASSESSMENT SERVICES, NAMELY, PROVIDING METABOLIC ASSESSMENT PROFILES (MAP) TO CLIENTS OBTAINED BY USING A PORTABLE METABOLIC MEASUREMENT SYSTEM IN THE NATURE OF A UNIQUE, HEART -RATE BASED OVERVIEW OF THEIR OWN METABOLISM IN ORDER TO ASSIST IN REACHING WEIGHT LOSS, SPORTS PERFORMANCE, HEALTH, FITNESS, AND WELLNESS-RELATED GOALS; HEALTH CARE SERVICES, NAMELY, HEALTH AND WELLNESS PROGRAMS IN FIELD OF CHILDHOOD OBESITY; HEALTH CARE SERVICES, NAMELY, WELLNESS PROGRAMS; HEALTH SPA SERVICES FOR HEALTH AND WELLNESS OF THE BODY AND SPIRIT; HEALTH SPA SERVICES FOR HEALTH AND WELLNESS OF THE BODY AND SPIRIT OFFERED AT A HEALTH CLUB FACILITY; HEALTH SPA SERVICES FOR HEALTH AND WELLNESS OF THE BODY AND SPIRIT OFFERED AT A HEALTH RESORT; HEALTH SPA SERVICES FOR HEALTH AND WELLNESS OF THE BODY AND SPIRIT, NAMELY, PROVIDING MASSAGE, FACIAL AND BODY TREATMENT SERVICES, COSMETIC BODY CARE SERVICES; HEALTH SPA SERVICES FOR HEALTH AND WELLNESS OF THE MIND, BODY AND SPIRIT OFFERED IN OR FROM A REMOTE, MOBILE OR TEMPORARY ON-SITE LOCATION; HEALTH SPA SERVICES, NAMELY, BODY WRAPS, MUD TREATMENTS, SEAWEED TREATMENTS, HYDROTHERAPY BATHS, AND BODY SCRUBS; HEALTH SPA SERVICES, NAMELY, COSMETIC BODY CARE SERVICES; HEALTH SPA SERVICES, NAMELY, LASER TREATMENTS FOR ACNE, REJUVENATION, SCARS, TATTOO REMOVAL AND FOR FACIALS AND MASSAGE; HEALTH SPA SERVICES, NAMELY, PROVIDING WEIGHT LOSS PROGRAMS; HOME HEALTH CARE SERVICES; INFORMATION IN THE FIELD OF PARENTING CONCERNING THE HEALTH OF CHILDREN; INTERNET-BASED HEALTH CARE INFORMATION SERVICES; MAKING RESERVATIONS AND BOOKINGS FOR OTHERS FOR PHYSICAL AND BEAUTY TREATMENTS AT HEALTH SPAS; MANAGED HEALTH CARE SERVICES; MEDICAL ASSISTANCE SERVICES PROVIDED VIA TELECOMMUNICATION AND GLOBAL COMPUTER NETWORKS FOR INDIVIDUALS WITH HEALTH PROBLEMS THROUGH THE USE OF WEARABLE MEDICAL DEVICES WITH AUTOMATED ALERT AND MONITORING CAPACITY; MEDSPA SERVICES FOR HEALTH AND BEAUTY OF THE BODY AND SPIRIT; MENTAL HEALTH COUNSELING AND PSYCHOTHERAPY AS IT RELATES TO RELATIONSHIPS; MENTAL HEALTH SERVICES; MENTAL HEALTH THERAPY SERVICES; PEDIATRIC HEALTH CARE SERVICES; PROVIDING A INTERACTIVE HOLISTIC WEB SITE FEATURING HEALTH INFORMATION AND PATIENT INITIATED, PATIENT AUTHORIZED, FEE-FOR-SERVICE, HOLISTIC APPROACH DISTANCE HEALING SESSIONS BASED ON THE PATIENT'S SPECIFIC SET OF SYMPTOMS, MEDICAL PROFILE AND MEDICAL RECORD ANALYSIS AND PATIENT BENEFIT INFORMATION CONCERNING ORGANIC AND HOLISTIC

CLASS 44—(Continued).

PRODUCTS AND SERVICES; PROVIDING A WEB SITE FEATURING INFORMATION IN THE FIELD OF MENTAL HEALTH AND PHYSICAL HEALTH, INCLUDING LIVING A HEALTHY AND DISEASE FREE LIFE; PROVIDING A WEB SITE FEATURING INFORMATION IN THE FIELD OF MENTAL HEALTH AND WELLNESS; PROVIDING A WEB SITE FEATURING INFORMATION ON HEALTH AND NUTRITION; PROVIDING A WEBSITE FEATURING CONTENT REGARDING HEALTHY LIVING AND LIFESTYLE WELLNESS; PROVIDING A WEBSITE FEATURING INFORMATION ABOUT HEALTH, NAMELY, HEPATITIS AWARENESS, DIAGNOSIS AND INFORMATION ABOUT SCREENING AND TREATMENT; PROVIDING A WEBSITE FEATURING INFORMATION ABOUT HEALTH, WELLNESS AND NUTRITION; PROVIDING A WEBSITE FEATURING INFORMATION AND ADVICE IN THE FIELDS OF DIET, WEIGHT LOSS, DIET PLANNING AND LIFESTYLE WELLNESS; PROVIDING A WEBSITE FEATURING INFORMATION CONCERNING ALTERNATIVE HEALTH AND HEALING; PROVIDING A WEBSITE FEATURING INFORMATION FOR PATIENTS IN THE FIELD OF DENTAL HEALTH; PROVIDING A WEBSITE VIA A GLOBAL COMPUTER NETWORK FEATURING INFORMATION AND COMPREHENSIVE CONTENT IN THE FIELDS OF HEALTH, CANCER, CANCER RECOVERY AND SURVIVAL; PROVIDING AN INTERNET WEBSITE FOR MEDICAL PROFESSIONALS AND MEDICAL PATIENTS FEATURING MEDICAL INFORMATION FROM REMOTE LOCATIONS VIA DEVICES THAT FEED INFORMATION TO THE WEBSITE THAT IS PROCESSED, EXCHANGED AND ACCESSED IN REAL-TIME BY USERS; PROVIDING AN INTERNET WEBSITE FOR MEDICAL PROFESSIONALS AND MEDICAL PATIENTS FEATURING MEDICAL INFORMATION FROM REMOTE LOCATIONS VIA ELECTRONIC PATIENT MONITORING DEVICES THAT FEED INFORMATION TO THE WEB SITE THAT CAN BE ACCESSED IN REAL-TIME BY MEDICAL PROFESSIONALS FOR PURPOSES OF MONITORING AND DIAGNOSING MEDICAL CONDITIONS; PROVIDING AN ON-LINE COMPUTER DATABASE FEATURING INFORMATION REGARDING HEALTH AND NUTRITION; PROVIDING AN ON-LINE SEARCHABLE DATABASE FEATURING HEALTH-RELATED INFORMATION ON ALL THE RISKS THAT COME WITH PREGNANCY AND DELIVERY FOR BOTH MOTHER AND BABY; PROVIDING ASSISTANCE, FITNESS EVALUATION AND CONSULTATION TO CORPORATE CLIENTS TO HELP THEIR EMPLOYEES MAKE HEALTH, WELLNESS AND NUTRITIONAL CHANGES IN THEIR DAILY LIVING TO IMPROVE HEALTH; PROVIDING ASSISTANCE, FITNESS EVALUATION AND CONSULTATION TO INDIVIDUALS TO HELP THEM MAKE HEALTH, WELLNESS AND NUTRITIONAL CHANGES IN THEIR DAILY LIVING TO IMPROVE HEALTH; PROVIDING HEALTH CARE INFORMATION BY TELEPHONE; PROVIDING HEALTH CARE INFORMATION BY TELEPHONE AND THE INTERNET; PROVIDING HEALTH INFORMATION; PROVIDING IN-PERSON HOLISTIC HEALTH CARE SERVICES; PROVIDING INFORMATION AND ADVICE IN THE FIELD OF PET HEALTH; PROVIDING INFORMATION, NEWS AND COMMENTARY IN THE FIELD OF NUTRITION, HEALTH AND WELLNESS; PROVIDING ON-LINE INFORMATION, NEWS AND COMMENTARY IN THE FIELD OF HEALTH AND WELLNESS RELATING TO ALL ASPECTS OF ACHIEVING A BETTER HEALTH, LIFESTYLE, AND LIFE CIRCUMSTANCE; PROVIDING WELLNESS SERVICES, NAMELY, PERSONAL ASSESSMENTS, PERSONALIZED ROUTINES, MAINTENANCE SCHEDULES, AND COUNSELING; PROVIDING WELLNESS SERVICES, NAMELY, WEIGHT LOSS PROGRAMS OFFERED AT A WELLNESS CENTER; PROVISION OF HEALTH CARE AND MEDICAL SERVICES BY HEALTH CARE PROFESSIONALS VIA THE INTERNET OR TELECOMMUNICATION NETWORKS; PROVISION OF MEDICAL SERVICES BY HEALTH CARE PROFESSIONALS VIA THE INTERNET OR TELECOMMUNICATION NETWORKS; REMOTE MONITORING OF DATA INDICATIVE OF THE

CLASS 44—(Continued).

HEALTH OR CONDITION OF AN INDIVIDUAL OR GROUP OF INDIVIDUALS; WEB-BASED HEALTH ASSESSMENT SERVICES, NAMELY, A SERIES OF HEALTH-RELATED QUESTIONS FOR RESPONSE FROM THE USER THAT RESULT IN A REPORT THAT PROVIDES HEALTH-RELATED INFORMATION IN THE FORM OF RECOMMENDED EDUCATIONAL RESOURCES AND TREATMENT INFORMATION; WEBSITES PROVIDING HEALTH INFORMATION IN THE SUSHI INDUSTRY; WELLNESS AND HEALTH-RELATED CONSULTING SERVICES (U.S. CLS. 100 AND 101).

FIRST USE 1-30-2005; IN COMMERCE 12-10-2010.
MATTHEW MCDOWELL, EXAMINING ATTORNEY

SN 85-267,712. THE CHRISTIAN AND MISSIONARY ALLIANCE FOUNDATION, INC., FT. MYERS, FL. FILED 3-15-2011.

SHELL POINT HEALTH SYSTEM

THE MARK CONSISTS OF STANDARD CHARACTERS WITHOUT CLAIM TO ANY PARTICULAR FONT, STYLE, SIZE, OR COLOR.

NO CLAIM IS MADE TO THE EXCLUSIVE RIGHT TO USE "HEALTH SYSTEM", APART FROM THE MARK AS SHOWN.

FOR HEALTH CARE SERVICES, NAMELY, PROVIDING SENIORS WITH NURSING CARE, MEMORY LOSS CARE, MEDICAL SERVICES, PHYSICAL REHABILITATION AND PHYSICAL THERAPY SERVICES, OCCUPATIONAL THERAPY SERVICES, AND HOSPICE CARE (U.S. CLS. 100 AND 101).

FIRST USE 1-1-2010; IN COMMERCE 1-1-2010.
BARBARA GAYNOR, EXAMINING ATTORNEY

SN 85-268,264. PLATINUM VIEW PROPERTIES, LLC, SAN DIEGO, CA. FILED 3-16-2011.

ULTIMATE CARB SWAP

THE MARK CONSISTS OF STANDARD CHARACTERS WITHOUT CLAIM TO ANY PARTICULAR FONT, STYLE, SIZE, OR COLOR.

OWNER OF U.S. REG. NO. 3,746,768.

NO CLAIM IS MADE TO THE EXCLUSIVE RIGHT TO USE "ULTIMATE CARB", APART FROM THE MARK AS SHOWN.

FOR WEIGHT REDUCTION DIET PLANNING AND SUPERVISION (U.S. CLS. 100 AND 101).

JENNY PARK, EXAMINING ATTORNEY

CLASS 44—(Continued).

SN 85-269,185. SUPIT, EDWIN J, DBA GRACIAMED, TAMUNING, GUAM, FILED 3-17-2011.

Graciamed

THE MARK CONSISTS OF STANDARD CHARACTERS WITHOUT CLAIM TO ANY PARTICULAR FONT, STYLE, SIZE, OR COLOR.

THE ENGLISH TRANSLATION OF "GRACIA" IN THE MARK IS "GRACE".

FOR COUNSELING SERVICES IN THE FIELDS OF HEALTH, NUTRITION AND LIFESTYLE WELLNESS; HEALTH CARE SERVICES, NAMELY, DISEASE MANAGEMENT PROGRAMS; HEALTH CARE SERVICES, NAMELY, WELLNESS PROGRAMS; MEDICAL CLINICS (U.S. CLS. 100 AND 101).

ELLEN B. AWRICH, EXAMINING ATTORNEY

CLASS 44—(Continued).

SN 85-269,621. GRANADA DENTAL, INC., LIVERMORE, CA. FILED S.R. 3-17-2011; AM. P.R. 6-21-2011.



THE MARK CONSISTS OF THE WORDS "GRANADA-DENTAL" BELOW A DESIGN OF A FACIAL SMILE ON A PAIR OF OFFSET SQUARE FIELDS.

FOR DENTISTRY (U.S. CLS. 100 AND 101).

FIRST USE 0-0-2002; IN COMMERCE 0-0-2002.

HANNO RITTNER, EXAMINING ATTORNEY

SN 85-270,834. 7COMPANY LLC, ALDIE, VA. FILED 3-18-2011.

SN 85-269,416. AMERICAN COLLEGE OF SPORTS MEDICINE, INC., INDIANAPOLIS, IN. FILED 3-17-2011.

LET'S MOVE HEALTHCARE

THE MARK CONSISTS OF STANDARD CHARACTERS WITHOUT CLAIM TO ANY PARTICULAR FONT, STYLE, SIZE, OR COLOR.

NO CLAIM IS MADE TO THE EXCLUSIVE RIGHT TO USE "HEALTHCARE", APART FROM THE MARK AS SHOWN.

FOR PROVIDING INFORMATION IN THE FIELD OF MEDICINE; PROVIDING EDUCATIONAL INFORMATION IN THE FIELD OF MEDICINE; AND, PROVIDING A WEBSITE FEATURING EDUCATIONAL INFORMATION IN THE FIELD OF MEDICINE (U.S. CLS. 100 AND 101).

FLORENTINA BLANDU, EXAMINING ATTORNEY



OWNER OF U.S. REG. NO. 3,192,665.

NO CLAIM IS MADE TO THE EXCLUSIVE RIGHT TO USE "WEIGHT LOSS & WELLNESS" AND "LLC", APART FROM THE MARK AS SHOWN.

THE MARK CONSISTS OF A STICK FIGURE IMAGE STRETCHING UPWARD WITH ONE ARM AND SEVEN BALLS IN A LINE OVER THE FIGURE'S HEAD AND ARMS AND THE WORDS "7COMPANY LLC" INSIDE A RECTANGULAR SHAPED BALLOON CARRIER OVER THE STYLIZED WORDS "WEIGHT LOSS & WELLNESS".

FOR MASSAGE THERAPY SERVICES; PROVIDING ASSISTANCE, FITNESS EVALUATION AND CONSULTATION TO INDIVIDUALS TO HELP THEM MAKE HEALTH, WELLNESS AND NUTRITIONAL CHANGES IN THEIR DAILY LIVING TO IMPROVE HEALTH; WEIGHT MANAGEMENT SERVICES, NAMELY, PROVIDING WEIGHT LOSS AND/OR WEIGHT MAINTENANCE PROGRAMS (U.S. CLS. 100 AND 101).

FIRST USE 11-30-2009; IN COMMERCE 11-30-2009.

ANDREA BUTLER, EXAMINING ATTORNEY

CLASS 44—(Continued).

SN 85-272,259. MANDARIN ORIENTAL SERVICES B.V., AMSTERDAM, NETHERLANDS, FILED 3-21-2011.

MANDARIN ORIENTAL

THE MARK CONSISTS OF STANDARD CHARACTERS WITHOUT CLAIM TO ANY PARTICULAR FONT, STYLE, SIZE, OR COLOR.

OWNER OF U.S. REG. NOS. 1,094,785, 3,317,907 AND OTHERS.

FOR HAIRDRESSING AND BARBERING SERVICES; BEAUTY SALONS; BEAUTY PARLOURS; PROVIDING TURKISH BATH FACILITIES, OPERATION OF SAUNA FACILITIES; MASSAGE PARLOURS; HEALTH SPA SERVICES FOR HEALTH AND WELLNESS OF THE BODY AND SPIRIT (U.S. CLS. 100 AND 101).

FIRST USE 12-1-2003; IN COMMERCE 12-1-2003.

JOHN SCHUYLER YARD, EXAMINING ATTORNEY

SN 85-272,581. NEFELI CORP, PORT WASHINGTON, NY, FILED 3-21-2011.

Nefeli Gua Sha Facial

THE MARK CONSISTS OF STANDARD CHARACTERS WITHOUT CLAIM TO ANY PARTICULAR FONT, STYLE, SIZE, OR COLOR.

OWNER OF U.S. REG. NO. 2,896,379.

NO CLAIM IS MADE TO THE EXCLUSIVE RIGHT TO USE "GUA SHA FACIAL", APART FROM THE MARK AS SHOWN.

FOR ACUPUNCTURE SERVICES; BEAUTY SALON SERVICES; BEAUTY SPA SERVICES, NAMELY, COSMETIC BODY CARE; CHIROPRACTIC SERVICES; COSMETIC BODY CARE SERVICES; COSMETIC FACE CARE SERVICES; COSMETIC SKIN CARE SERVICES; ENERGY HEALING SERVICES, NAMELY, THERAPEUTIC TOUCH SERVICES; HEALTH CARE; HEALTH CARE SERVICES, NAMELY, GUA SHA THERAPY FOR DEEP TISSUE AND FASCIAL RELEASE; HEALTH CARE SERVICES, NAMELY, WELLNESS PROGRAMS; HEALTH SPA SERVICES FOR HEALTH AND WELLNESS OF THE BODY AND SPIRIT; HEALTH SPA SERVICES FOR HEALTH AND WELLNESS OF THE BODY AND SPIRIT OFFERED AT A HEALTH CLUB FACILITY; HEALTH SPA SERVICES FOR HEALTH AND WELLNESS OF THE BODY AND SPIRIT OFFERED AT A HEALTH RESORT; HEALTH SPA SERVICES FOR HEALTH AND WELLNESS OF THE BODY AND SPIRIT, NAMELY, PROVIDING MASSAGE, FACIAL AND BODY TREATMENT SERVICES, COSMETIC BODY CARE SERVICES; HEALTH SPA SERVICES, NAMELY, COSMETIC

CLASS 44—(Continued).

BODY CARE SERVICES; MASSAGE THERAPY SERVICES; MEDICAL SPA SERVICES, NAMELY, MINIMALLY AND NON-INVASIVE COSMETIC AND BODY FITNESS THERAPIES; MEDSPA SERVICES FOR HEALTH AND BEAUTY OF THE BODY AND SPIRIT; PROVIDING IN-PERSON ENERGY HEALING SERVICES; PROVIDING IN-PERSON HOLISTIC HEALTH CARE SERVICES; PROVIDING WEIGHT LOSS PROGRAM SERVICES; PROVIDING WEIGHT LOSS PROGRAMS AND COSMETIC BODY CARE SERVICES IN THE NATURE OF NON-SURGICAL BODY CONTOURING; PSYCHOTHERAPY COMPLEMENTED BY BODY WORK, NAMELY, MYOFASCIAL PHYSICAL THERAPY TECHNIQUES; SALON SERVICES, NAMELY, FACIALS, MANICURES AND MESSAGES THAT ARE PROVIDED IN A TRAILER OUTFITTED WITH CHAIR, TABLE AND SINK ACCESSORIES; SKIN CARE SALONS; STRETCH MARK TREATMENT SERVICES; WEIGHT MANAGEMENT SERVICES, NAMELY, PROVIDING WEIGHT LOSS AND/OR WEIGHT MAINTENANCE PROGRAMS (U.S. CLS. 100 AND 101).

HEATHER BIDDULPH, EXAMINING ATTORNEY

SN 85-272,584. NEFELI CORP, PORT WASHINGTON, NY, FILED 3-21-2011.

Nefeli Myofascial Gua Sha

THE MARK CONSISTS OF STANDARD CHARACTERS WITHOUT CLAIM TO ANY PARTICULAR FONT, STYLE, SIZE, OR COLOR.

OWNER OF U.S. REG. NO. 2,896,379.

NO CLAIM IS MADE TO THE EXCLUSIVE RIGHT TO USE "MYOFASCIAL GUA SHA", APART FROM THE MARK AS SHOWN.

FOR ACUPUNCTURE SERVICES; BEAUTY SALON SERVICES; BEAUTY SPA SERVICES, NAMELY, COSMETIC BODY CARE; CHIROPRACTIC SERVICES; COSMETIC BODY CARE SERVICES; COSMETIC FACE CARE SERVICES; COSMETIC SKIN CARE SERVICES; ENERGY HEALING SERVICES, NAMELY, THERAPEUTIC TOUCH SERVICES; HEALTH CARE; HEALTH CARE SERVICES, NAMELY, GUA SHA THERAPY FOR DEEP TISSUE AND FASCIAL RELEASE; HEALTH CARE SERVICES, NAMELY, WELLNESS PROGRAMS; HEALTH SPA SERVICES FOR HEALTH AND WELLNESS OF THE BODY AND SPIRIT; HEALTH SPA SERVICES FOR HEALTH AND WELLNESS OF THE BODY AND SPIRIT OFFERED AT A HEALTH CLUB FACILITY; HEALTH SPA SERVICES FOR HEALTH AND WELLNESS OF THE BODY AND SPIRIT OFFERED AT A HEALTH RESORT; HEALTH SPA SERVICES FOR HEALTH AND WELLNESS OF THE BODY AND SPIRIT, NAMELY, PROVIDING MASSAGE, FACIAL AND BODY TREATMENT SERVICES, COSMETIC BODY CARE SERVICES; HEALTH SPA SERVICES, NAMELY, COSMETIC

CLASS 44—(Continued).

BODY CARE SERVICES; MASSAGE THERAPY SERVICES; MEDICAL SPA SERVICES, NAMELY, MINIMALLY AND NON-INVASIVE COSMETIC AND BODY FITNESS THERAPIES; MEDSPA SERVICES FOR HEALTH AND BEAUTY OF THE BODY AND SPIRIT; PROVIDING IN-PERSON ENERGY HEALING SERVICES; PROVIDING IN-PERSON HOLISTIC HEALTH CARE SERVICES; PROVIDING WEIGHT LOSS PROGRAM SERVICES; PROVIDING WEIGHT LOSS PROGRAMS AND COSMETIC BODY CARE SERVICES IN THE NATURE OF NON-SURGICAL BODY CONTOURING; PSYCHOTHERAPY COMPLEMENTED BY BODY WORK, NAMELY, MYOFASCIAL PHYSICAL THERAPY TECHNIQUES; SALON SERVICES, NAMELY, FACIALS, MANICURES AND MASSAGES THAT ARE PROVIDED IN A TRAILER OUTFITTED WITH CHAIR, TABLE AND SINK ACCESSORIES; SKIN CARE SALONS; STRETCH MARK TREATMENT SERVICES; WEIGHT MANAGEMENT SERVICES, NAMELY, PROVIDING WEIGHT LOSS AND/OR WEIGHT MAINTENANCE PROGRAMS (U.S. CLS. 100 AND 101).

HEATHER BIDDULPH, EXAMINING ATTORNEY

SN 85-273,226. ARMSTRONG & ESHLEMAN, P.A., CHARLOTTE, NC. FILED 3-22-2011.

Charlotte Dentistry

THE MARK CONSISTS OF STANDARD CHARACTERS WITHOUT CLAIM TO ANY PARTICULAR FONT, STYLE, SIZE, OR COLOR.

NO CLAIM IS MADE TO THE EXCLUSIVE RIGHT TO USE "DENTISTRY", APART FROM THE MARK AS SHOWN.

SEC. 2(F).

FOR COSMETIC DENTISTRY; DENTAL HYGIENIST SERVICES; DENTAL SERVICES, NAMELY, PERFORMING RESTORATIVE AND COSMETIC PROCEDURES; DENTIST SERVICES; DENTISTRY; ORTHODONTIC SERVICES; TEETH WHITENING SERVICES (U.S. CLS. 100 AND 101).

FIRST USE 12-18-1998; IN COMMERCE 12-18-1998.

JOHN KELLY, EXAMINING ATTORNEY

SN 85-273,264. ARMSTRONG & ESHLEMAN, P.A., CHARLOTTE, NC. FILED 3-22-2011.



NO CLAIM IS MADE TO THE EXCLUSIVE RIGHT TO USE "DENTISTRY", APART FROM THE MARK AS SHOWN.

SEC. 2(F).

FOR COSMETIC DENTISTRY; DENTAL HYGIENIST SERVICES; DENTAL SERVICES, NAMELY, PERFORMING RESTORATIVE AND COSMETIC PROCEDURES; DENTIST SERVICES; DENTISTRY; ORTHODONTIC SERVICES; TEETH WHITENING SERVICES (U.S. CLS. 100 AND 101).

FIRST USE 12-18-1998; IN COMMERCE 12-18-1998.

JOHN KELLY, EXAMINING ATTORNEY

CLASS 44—(Continued).

SN 85-274,116. BUOYE, TIMOTHY, CHERRY VALLY, CA. FILED 3-23-2011.

LIQUID GOLD APIARY

THE MARK CONSISTS OF STANDARD CHARACTERS WITHOUT CLAIM TO ANY PARTICULAR FONT, STYLE, SIZE, OR COLOR.

NO CLAIM IS MADE TO THE EXCLUSIVE RIGHT TO USE "APIARY", APART FROM THE MARK AS SHOWN.

FOR BEEKEEPING SERVICES (U.S. CLS. 100 AND 101).

CHARLES L. JENKINS, EXAMINING ATTORNEY

SN 85-274,157. BALANCE AND BEAM, LLC, JAMAICA PLAIN, MA. FILED 3-23-2011.



THE COLOR(S) ORANGE AND GREEN IS/ARE CLAIMED AS A FEATURE OF THE MARK.

THE MARK CONSISTS OF THE TERM "NOURISH LIFE." IN ORANGE AND "EAT WELL." IN GREEN.

FOR NUTRITION COUNSELING; PROVIDING A WEB SITE FEATURING INFORMATION ON HEALTH AND NUTRITION (U.S. CLS. 100 AND 101).

FIRST USE 9-15-2010; IN COMMERCE 9-15-2010.

KAPIL BHANOT, EXAMINING ATTORNEY

SN 85-275,535. MICHAEL MYLONAS, AUSTIN, TX. FILED 3-24-2011.

Only the Best Landscapes

THE MARK CONSISTS OF STANDARD CHARACTERS WITHOUT CLAIM TO ANY PARTICULAR FONT, STYLE, SIZE, OR COLOR.

NO CLAIM IS MADE TO THE EXCLUSIVE RIGHT TO USE "LANDSCAPES", APART FROM THE MARK AS SHOWN.

FOR LANDSCAPE DESIGN; LANDSCAPE GARDENING; LANDSCAPE GARDENING DESIGN FOR OTHERS (U.S. CLS. 100 AND 101).

JAY FLOWERS, EXAMINING ATTORNEY

CLASS 44—(Continued).

SN 85-276,852. FOGAN, SARA, VALENCIA, CA. FILED 3-25-2011.

Calminsense Hypnotherapy

THE MARK CONSISTS OF STANDARD CHARACTERS WITHOUT CLAIM TO ANY PARTICULAR FONT, STYLE, SIZE, OR COLOR.

NO CLAIM IS MADE TO THE EXCLUSIVE RIGHT TO USE "HYPNOTHERAPY", APART FROM THE MARK AS SHOWN.

FOR HYPNOSIS SERVICES; REIKI ENERGY-HEALING SERVICES; THERAPEUTIC GUIDED IMAGERY SERVICES; AND NEUROLINGUISTIC PROGRAMMING SERVICES (U.S. CLS. 100 AND 101).

FIRST USE 6-23-2005; IN COMMERCE 6-23-2005.
ROBIN CHOSID, EXAMINING ATTORNEY

SN 85-277,176. MELANIE ZOOK, LANSDALE, PA. FILED 3-25-2011.

FRESH START NUTRITION

THE MARK CONSISTS OF STANDARD CHARACTERS WITHOUT CLAIM TO ANY PARTICULAR FONT, STYLE, SIZE, OR COLOR.

NO CLAIM IS MADE TO THE EXCLUSIVE RIGHT TO USE "NUTRITION", APART FROM THE MARK AS SHOWN.

FOR COUNSELING SERVICES IN THE FIELDS OF HEALTH, NUTRITION AND LIFESTYLE WELLNESS; FOOD NUTRITION CONSULTATION; PROVIDING A WEBSITE FEATURING INFORMATION ABOUT HEALTH, WELLNESS AND NUTRITION; PROVIDING HEALTHY LIFESTYLE AND NUTRITION SERVICES, NAMELY, PERSONAL ASSESSMENTS, PERSONALIZED ROUTINES, MAINTENANCE SCHEDULES, AND COUNSELING; PROVIDING INFORMATION, NEWS AND COMMENTARY IN THE FIELD OF NUTRITION, HEALTH AND WELLNESS (U.S. CLS. 100 AND 101).

FIRST USE 8-0-2010; IN COMMERCE 8-0-2010.
PATRICIA EVANKO, EXAMINING ATTORNEY

CLASS 44—(Continued).

SN 85-278,087. MASSAGE HEIGHTS IP, LLC, SAN ANTONIO, TX. FILED 3-27-2011.



OWNER OF U.S. REG. NOS. 3,108,570, 3,437,048 AND 3,511,031.

NO CLAIM IS MADE TO THE EXCLUSIVE RIGHT TO USE "FACE" OR "MASSAGE", APART FROM THE MARK AS SHOWN.

THE COLOR(S) BLUE AND WHITE IS/ARE CLAIMED AS A FEATURE OF THE MARK.

THE MARK CONSISTS OF A BLUE CIRCLE WITH THE WORD "FACE" WRITTEN IN THE MIDDLE IN WHITE LETTERS AND THE WORDS "BY MASSAGE HEIGHTS" IN WHITE LETTERS WRITTEN BELOW THE WORD FACE INSIDE THE CIRCLE.

FOR HEALTH SPA SERVICES FOR HEALTH AND WELLNESS OF THE BODY AND SPIRIT, NAMELY, PROVIDING MASSAGE, FACIAL AND BODY TREATMENT SERVICES, COSMETIC BODY CARE SERVICES (U.S. CLS. 100 AND 101).

FIRST USE 9-24-2010; IN COMMERCE 9-24-2010.
THEODORE MCBRIDE, EXAMINING ATTORNEY

SN 85-286,049. PEDIATRIC ACUTE CARE MEDICAL ASSOCIATES, INC., TARZANA, CA. FILED 4-5-2011.



NO CLAIM IS MADE TO THE EXCLUSIVE RIGHT TO USE "PEDIATRIC URGENT CARE", APART FROM THE MARK AS SHOWN.

THE COLOR(S) RED, BLACK, BROWN, WHITE, PINK, GREY, TAN, BLUE, YELLOW, BEIGE, GREEN, PURPLE, AND ORANGE IS/ARE CLAIMED AS A FEATURE OF THE MARK.

THE MARK CONSISTS OF, WRITTEN AT THE TOP IS "PEDIATRIC URGENT CARE" IN RED, ORANGE, PINK, GREEN, BLUE AND PURPLE, UNDERNEATH IS A HUT MADE FROM BAMBOO IN BROWN ENCLOSEING A RHINO AT THE CENTER IN GREY, WHITE, PINK AND BLUE, TO THE LEFT IS A BOY IN BEIGE, TAN, WHITE, BLACK, BLUE, BROWN, AND PINK WHO IS WINKING AND

CLASS 44—(Continued).

GIVING THUMBS UP IN A SAFARI HAT, BENEATH HIM IS A MONKEY IN BROWN, BLACK, WHITE AND PINK, ABOVE AND TO THE SIDE OF THE BOY IS A BIRD IN BLACK, WHITE, YELLOW, AND PINK, ABOVE THE BIRD AND TO EITHER SIDE OF THE RHINO ARE TWO PINK FLOWERS WITH GREEN LEAVES, TO THE RIGHT OF THE RHINO IS A GIRL IN BEIGE, TAN, PINK, YELLOW, BLACK, AND WHITE WEARING A SAFARI HAT AND BENEATH HER IS A CHEETAH IN BLACK, BROWN, TANK, PINK AND WHITE.

FOR PEDIATRIC HEALTH CARE SERVICES; URGENT MEDICAL CARE CENTERS (U.S. CLS. 100 AND 101).

FIRST USE 1-1-2003; IN COMMERCE 1-1-2003.
JOHN WILKE, EXAMINING ATTORNEY

SN 85-289,630. RODRIGO ARGENAL MD PA, DBA ARGENAL PEDIATRICS, MCALLEN, TX. FILED 4-7-2011.



NO CLAIM IS MADE TO THE EXCLUSIVE RIGHT TO USE "PEDIATRICS", APART FROM THE MARK AS SHOWN.

THE COLOR(S) RED, BLUE AND WHITE IS/ARE CLAIMED AS A FEATURE OF THE MARK.

THE MARK CONSISTS OF A SQUARE OF SOLID RED COLOR, WITH AN ARTISTIC REPRESENTATION OF THE CAPITAL LETTER "A" IN WHITE, EMBEDDED IN THE CENTER OF THE SQUARE, SURROUNDED BY THE SILHOUETTE IN WHITE OF THREE KIDS AND THEIR THREE TOYS, OUTLINED IN BLUE, LOCATED AS FOLLOWS: BELOW THE LETTER "A" THERE IS THE SILHOUETTE IN WHITE, OF A TODDLER ON CRAWLING POSITION, PLAYING WITH AN ELEPHANT TOY, OUTLINED IN BLUE; TO THE LEFT OF THE LETTER "A" THERE IS A STANDING SILHOUETTE OF A YOUNG GIRL IN WHITE, HOLDING A BALL, OUTLINED IN BLUE; AND TO THE RIGHT OF THE LETTER "A" THERE IS A STANDING SILHOUETTE OF AN ADOLESCENT BOY IN WHITE, HOLDING A ROLLER SKATE BOARD, OUTLINED IN BLUE; FOLLOWED TO THE RIGHT BY THE WORD "ARGENAL" IN BLUE ON TOP OF THE WORD "PEDIATRICS" IN RED.

FOR PEDIATRIC HEALTH CARE SERVICES (U.S. CLS. 100 AND 101).

FIRST USE 10-15-2010; IN COMMERCE 10-15-2010.
TEJBIR SINGH, EXAMINING ATTORNEY

SN 85-289,645. PLATINUM VIEW PROPERTIES, LLC, SAN DIEGO, CA. FILED 4-7-2011.

AGE MORE CARB SWAPS

THE MARK CONSISTS OF STANDARD CHARACTERS WITHOUT CLAIM TO ANY PARTICULAR FONT, STYLE, SIZE, OR COLOR.

OWNER OF U.S. REG. NO. 3,746,768.

NO CLAIM IS MADE TO THE EXCLUSIVE RIGHT TO USE "CARB", APART FROM THE MARK AS SHOWN.

FOR WEIGHT REDUCTION DIET PLANNING AND SUPERVISION (U.S. CLS. 100 AND 101).

JENNY PARK, EXAMINING ATTORNEY

CLASS 44—(Continued).

SN 85-289,646. PLATINUM VIEW PROPERTIES, LLC, SAN DIEGO, CA. FILED 4-7-2011.

AGE LESS CARB SWAPS

THE MARK CONSISTS OF STANDARD CHARACTERS WITHOUT CLAIM TO ANY PARTICULAR FONT, STYLE, SIZE, OR COLOR.

OWNER OF U.S. REG. NO. 3,746,768.

NO CLAIM IS MADE TO THE EXCLUSIVE RIGHT TO USE "CARB", APART FROM THE MARK AS SHOWN.

FOR WEIGHT REDUCTION DIET PLANNING AND SUPERVISION (U.S. CLS. 100 AND 101).

JENNY PARK, EXAMINING ATTORNEY

SN 85-290,296. U.S. MEDICAL MANAGEMENT LLC, FARMINGTON HILLS, MI. FILED 4-8-2011.



NO CLAIM IS MADE TO THE EXCLUSIVE RIGHT TO USE "VISITING PODIATRY" AND THE CADUCEUS SYMBOL, APART FROM THE MARK AS SHOWN.

THE MARK CONSISTS OF THE WORDS "VISITING" AND "PODIATRY" ARE SEPARATED BY TWO BOXES ALONGSIDE EACH OTHER. THE FIRST BOX CONTAINS A CADUCEUS. THE SECOND BOX CONTAINS THE IMAGE OF A HUMAN FOOT AND ANKLE.

FOR MEDICAL SERVICES, NAMELY, PODIATRY SERVICES RENDERED IN THE HOME (U.S. CLS. 100 AND 101).

MAYUR VAGHANI, EXAMINING ATTORNEY

SN 85-290,526. VEIN CLINICS OF AMERICA, INC., DOWNERS GROVE, IL. FILED 4-8-2011.

VEIN CLINICS OF AMERICA

THE MARK CONSISTS OF STANDARD CHARACTERS WITHOUT CLAIM TO ANY PARTICULAR FONT, STYLE, SIZE, OR COLOR.

OWNER OF U.S. REG. NOS. 3,072,943 AND 3,127,877.

NO CLAIM IS MADE TO THE EXCLUSIVE RIGHT TO USE "VEIN CLINICS", APART FROM THE MARK AS SHOWN.

SEC. 2(F).

FOR MEDICAL SERVICES, NAMELY, DIAGNOSIS AND TREATMENT OF VENOUS DISEASES AND DISORDERS (U.S. CLS. 100 AND 101).

FIRST USE 4-0-1986; IN COMMERCE 6-0-1988.

BRIAN PINO, EXAMINING ATTORNEY

CLASS 44—(Continued).

SN 85-290,912. FAMILY SERVICE AGENCY OF SAN FRANCISCO, SAN FRANCISCO, CA. FILED 4-9-2011.

PREP

THE MARK CONSISTS OF STANDARD CHARACTERS WITHOUT CLAIM TO ANY PARTICULAR FONT, STYLE, SIZE, OR COLOR.

FOR MENTAL HEALTH THERAPY SERVICES (U.S. CLS. 100 AND 101).

FIRST USE 4-1-2007; IN COMMERCE 4-1-2007.
GISELLE AGOSTO, EXAMINING ATTORNEY

SN 85-291,104. INDUSTRIAL PRIMITIVES LLC, DBA INDUSTRIAL PRIMITIVES, AUSTIN, TX. FILED 4-9-2011.



THE COLOR(S) YELLOW, ORANGE, BLACK, AND WHITE IS/ARE CLAIMED AS A FEATURE OF THE MARK.

THE MARK CONSISTS OF A SIDE VIEW OF A HUMAN MALE FACE. IT IS SHADED IN COLORS OF ORANGE, YELLOW, WHITE, AND BLACK. THE FACE IS TATTOOED WITH TRIBAL DESIGNS. THE EARLOBE IS OF A STRETCHED PIERCING. THERE ARE THREE PIERCINGS NEAR THE EYE. THE SEPTUM IS PIERCED AS ARE THE CHEEKS AND LIPS. THE EAR IS POINTED. THERE ARE BLACK SLASH MARKS IN THE DETAIL OF THE DESIGN. THE DESIGN CAN ALSO BE DONE IN BLACK AND GREY COLORS. AROUND THE OUTSIDE OF THE FACE IS THE WORDS "INDUSTRIAL PRIMITIVES".

FOR BODY PIERCING SERVICES (U.S. CLS. 100 AND 101).

FIRST USE 5-5-2005; IN COMMERCE 6-5-2005.
MARGERY A. TIERNEY, EXAMINING ATTORNEY

CLASS 44—(Continued).

SN 85-291,511. SHAH EYE CENTER, PA, MISSION, TX. FILED 4-11-2011.

Founded on a vision of excellence.

THE MARK CONSISTS OF STANDARD CHARACTERS WITHOUT CLAIM TO ANY PARTICULAR FONT, STYLE, SIZE, OR COLOR.

FOR OPHTHALMOLOGY SERVICES (U.S. CLS. 100 AND 101).

JULIE GUTTADAURO, EXAMINING ATTORNEY

SN 85-291,582. LUTHERAN FAMILY SERVICES OF NEBRASKA, INC., AKA LFS, OMAHA, NE. FILED 4-11-2011.

RSAFE

THE MARK CONSISTS OF STANDARD CHARACTERS WITHOUT CLAIM TO ANY PARTICULAR FONT, STYLE, SIZE, OR COLOR.

FOR MENTAL HEALTH COUNSELING AND PSYCHOTHERAPY AS IT RELATES TO RELATIONSHIPS; PSYCHOTHERAPY AND PSYCHOTHERAPY COUNSELING FOR CHILDREN AND ADULTS IN INDIVIDUAL AND FAMILY SESSIONS (U.S. CLS. 100 AND 101).

FIRST USE 3-31-2011; IN COMMERCE 3-31-2011.
JUSTINE D. PARKER, EXAMINING ATTORNEY

SN 85-291,655. BISTRO 24, LLC, DETROIT, MI. FILED 4-11-2011.

SPA19

THE MARK CONSISTS OF STANDARD CHARACTERS WITHOUT CLAIM TO ANY PARTICULAR FONT, STYLE, SIZE, OR COLOR.

FOR HEALTH SPA SERVICES FOR HEALTH AND WELLNESS OF THE BODY AND SPIRIT, NAMELY, PROVIDING MASSAGE, FACIAL AND BODY TREATMENT SERVICES, COSMETIC BODY CARE SERVICES; DAY SPA SERVICES, NAMELY, NAIL CARE, MANICURES, PEDICURES AND NAIL ENHANCEMENTS (U.S. CLS. 100 AND 101).

FIRST USE 2-1-2009; IN COMMERCE 2-1-2009.
BRENDAN MCCAULEY, EXAMINING ATTORNEY

CLASS 44—(Continued).

SN 85-291,866. AUXILIUM US HOLDINGS, LLC, WILMINGTON, DE. FILED 4-11-2011.

XIAPEX

THE MARK CONSISTS OF STANDARD CHARACTERS WITHOUT CLAIM TO ANY PARTICULAR FONT, STYLE, SIZE, OR COLOR.

FOR PROVIDING INFORMATION ON THE SUBJECT OF HEALTH CARE AND THE DIAGNOSTIC, PROPHYLACTIC AND THERAPEUTIC PROPERTIES OF PHARMACEUTICALS (U.S. CLS. 100 AND 101).
CAROLINE WOOD, EXAMINING ATTORNEY

CLASS 44—(Continued).

SN 85-292,667. WILLIAM BEAUMONT HOSPITAL, ROYAL OAK, MI. FILED 4-12-2011.

WE NEVER FORGET THAT YOU
PLACE IN OUR HANDS THE
MOST PRECIOUS THING OF
ALL...THE LIFE OF SOMEONE
YOU LOVE.

THE MARK CONSISTS OF STANDARD CHARACTERS WITHOUT CLAIM TO ANY PARTICULAR FONT, STYLE, SIZE, OR COLOR.

FOR HEALTH CARE; MEDICAL SERVICES (U.S. CLS. 100 AND 101).
FIRST USE 5-30-2011; IN COMMERCE 5-30-2011.
RONALD MCMORROW, EXAMINING ATTORNEY

SN 85-292,010. GOLDBERG, MICHAEL, ENGELWOOD, NJ. FILED 4-11-2011.

THE DOCTOR'S DENTIST

THE MARK CONSISTS OF STANDARD CHARACTERS WITHOUT CLAIM TO ANY PARTICULAR FONT, STYLE, SIZE, OR COLOR.

NO CLAIM IS MADE TO THE EXCLUSIVE RIGHT TO USE "DENTIST", APART FROM THE MARK AS SHOWN.
FOR DENTIST SERVICES (U.S. CLS. 100 AND 101).
ELLEN B. AWRICH, EXAMINING ATTORNEY

SN 85-293,378. PETSMART STORE SUPPORT GROUP, INC., PHOENIX, AZ. FILED 4-12-2011.

LOOK GREAT GUARANTEE YOU'RE HAPPY OR IT'S FREE!

THE MARK CONSISTS OF STANDARD CHARACTERS WITHOUT CLAIM TO ANY PARTICULAR FONT, STYLE, SIZE, OR COLOR.

FOR PET GROOMING SERVICES; PROVIDING INFORMATION ABOUT PET GROOMING SERVICES (U.S. CLS. 100 AND 101).
RUSS HERMAN, EXAMINING ATTORNEY

SN 85-292,596. THE JASON FOUNDATION, INC., HENDERSONVILLE, TN. FILED 4-12-2011.

GUARD YOUR BUDDY

THE MARK CONSISTS OF STANDARD CHARACTERS WITHOUT CLAIM TO ANY PARTICULAR FONT, STYLE, SIZE, OR COLOR.

FOR MENTAL HEALTH SERVICES; PROVIDING A WEB SITE FEATURING INFORMATION IN THE FIELD OF MENTAL HEALTH AND WELLNESS (U.S. CLS. 100 AND 101).
LINDA E. BLOHM, EXAMINING ATTORNEY

SN 85-294,884. HOPKINS, CHRISTOPHER J, MINNEAPOLIS, MN. FILED 4-14-2011.

THE POWER OF PRETTY

THE MARK CONSISTS OF STANDARD CHARACTERS WITHOUT CLAIM TO ANY PARTICULAR FONT, STYLE, SIZE, OR COLOR.

FOR IMAGE CONSULTING SERVICES, NAMELY COSMETIC ANALYSIS AND MAKEOVERS (U.S. CLS. 100 AND 101).
MATTHEW KLINE, EXAMINING ATTORNEY

CLASS 44—(Continued).

SN 85-296,804. THIS ABLE VETERAN, NFP, AKA TAV, CARBONDALE, IL. FILED 4-15-2011.



THE COLOR(S) RED, WHITE AND BLACK IS/ARE CLAIMED AS A FEATURE OF THE MARK.

THE MARK CONSISTS OF A BLACK PUPPY IN FRONT OF A RED BACKGROUND AND BLACK CIRCLE. THE PUPPY IS OUTLINED IN WHITE. TO THE RIGHT ARE THE WORDS "THIS ABLE VETERAN". "THIS" AND "VETERAN" ARE IN BLACK. "ABLE" IS IN RED. BELOW ALL OF THIS IS A BLACK STRIPE WITH FIVE EQUALLY SPACED WHITE STARS.

FOR CHARITABLE SERVICES, NAMELY, PROVIDING TRAINED SERVICE DOGS FOR VETERANS (U.S. CLS. 100 AND 101).

FIRST USE 3-23-2011; IN COMMERCE 4-7-2011.
JESSICA A. POWERS, EXAMINING ATTORNEY

SN 85-296,816. THIS ABLE VETERAN, NFP, AKA TAV, CARBONDALE, IL. FILED 4-15-2011.



THE COLOR(S) RED, BLACK AND WHITE IS/ARE CLAIMED AS A FEATURE OF THE MARK.

THE MARK CONSISTS OF A BLACK PUPPY IN FRONT OF A RED BACKGROUND AND BLACK CIRCLE. THE PUPPY IS OUTLINED IN WHITE. UNDER THE PUPPY ARE THE WORDS "THIS ABLE VETERAN". "THIS" AND "VETERAN" ARE IN BLACK. "ABLE" IS IN RED. BELOW ALL OF THIS ARE FIVE EQUALLY SPACED RED STARS. EVERYTHING IS OUTLINED IN WHITE.

FOR CHARITABLE SERVICES, NAMELY, PROVIDING TRAINED SERVICE DOGS FOR VETERANS (U.S. CLS. 100 AND 101).

FIRST USE 3-23-2011; IN COMMERCE 4-7-2011.
JESSICA A. POWERS, EXAMINING ATTORNEY

CLASS 44—(Continued).

SN 85-309,801. GENESIS IP, LLC, KENNETT SQUARE, PA. FILED 5-2-2011.

PCH

THE MARK CONSISTS OF STANDARD CHARACTERS WITHOUT CLAIM TO ANY PARTICULAR FONT, STYLE, SIZE, OR COLOR.

FOR PHYSICAL REHABILITATION SERVICES, NAMELY, METRICS USED TO MEASURE THERAPIST EFFICIENCY (U.S. CLS. 100 AND 101).

KAPIL BHANOT, EXAMINING ATTORNEY

SN 85-311,072. FULOP-GOODLING, JACQUELINE I., WOODBURY, NY. FILED 5-3-2011.

**Just Melt
Into Your Perfect Self**

THE MARK CONSISTS OF STANDARD CHARACTERS WITHOUT CLAIM TO ANY PARTICULAR FONT, STYLE, SIZE, OR COLOR.

FOR MEDICAL SPA SERVICES, NAMELY MINIMALLY AND NON-INVASIVE COSMETIC AND BODY FITNESS THERAPIES; COSMETIC AND PLASTIC SURGERY (U.S. CLS. 100 AND 101).

FIRST USE 2-1-2011; IN COMMERCE 4-30-2011.
JACLYN KIDWELL WALKER, EXAMINING ATTORNEY

SN 85-311,120. FULOP-GOODLING, JACQUELINE I., WOODBURY, NY. FILED 5-3-2011.

JUST MELT

THE MARK CONSISTS OF STANDARD CHARACTERS WITHOUT CLAIM TO ANY PARTICULAR FONT, STYLE, SIZE, OR COLOR.

FOR MEDICAL SPA SERVICES, NAMELY MINIMALLY AND NON-INVASIVE COSMETIC AND BODY FITNESS THERAPIES; COSMETIC AND PLASTIC SURGERY (U.S. CLS. 100 AND 101).

FIRST USE 2-1-2011; IN COMMERCE 4-30-2011.
JACLYN KIDWELL WALKER, EXAMINING ATTORNEY

CLASS 44—(Continued).

SN 85-311,379. BLO BLOW DRY BAR, INC., TORONTO, ONTARIO, CANADA, FILED 5-3-2011.

CLASS 45—(Continued).

SN 77-788,252. EQUAL RIGHTS CENTER, WASHINGTON, DC. FILED 7-23-2009.

**YOU'RE NOT CHEATING ON
YOUR HAIRDRESSER**

THE MARK CONSISTS OF STANDARD CHARACTERS WITHOUT CLAIM TO ANY PARTICULAR FONT, STYLE, SIZE, OR COLOR.

FOR HAIR SALON SERVICES; HAIR STYLING; PROVIDING ON-SITE BEAUTY SERVICES, NAMELY, HAIR STYLING AND MAKE-UP APPLICATION SERVICES (U.S. CLS. 100 AND 101).

FIRST USE 4-0-2010; IN COMMERCE 4-0-2010.
DARRYL SPRULL, EXAMINING ATTORNEY



**MULTIFAMILY HOUSING
RESOURCE PROGRAM**

NO CLAIM IS MADE TO THE EXCLUSIVE RIGHT TO USE "MULTIFAMILY HOUSING RESOURCE PROGRAM", APART FROM THE MARK AS SHOWN.

THE MARK CONSISTS OF THE WORDING "MHRP MULTIFAMILY HOUSING RESOURCE PROGRAM" TOGETHER WITH A STYLIZED DEPICTION OF A BUILDING.

FOR REGULATORY COMPLIANCE CONSULTING IN THE FIELD OF FAIR HOUSING POLICY AND CORPORATE POLICY IN CONNECTION THEREWITH; PREPARING CONFIDENTIAL REGULATORY COMPLIANCE EVALUATIONS AND REPORTS RELATING TO FAIR HOUSING (U.S. CLS. 100 AND 101).

FIRST USE 2-2-2009; IN COMMERCE 2-2-2009.
JESSICA FATHY, EXAMINING ATTORNEY

CLASS 45—PERSONAL AND LEGAL SERVICES

SN 76-706,160. GOLDBERG, BRANDON R., OLD BETHPAGE, NY. FILED 1-28-2011.

SN 77-850,908. PEERIOSITY, LLC, CARDIFF, CA. FILED 10-16-2009.

THINKONNECT

THE MARK CONSISTS OF STANDARD CHARACTERS WITHOUT CLAIM TO ANY PARTICULAR FONT, STYLE, SIZE, OR COLOR.

FOR SOCIAL NETWORKING SERVICES FOR DESIGNERS OF ARCHITECTURAL DISCIPLINES TO CONNECT WITH EACH OTHER (U.S. CLS. 100 AND 101).

MARK RADEMACHER, EXAMINING ATTORNEY

PEERIOSITY

THE MARK CONSISTS OF STANDARD CHARACTERS WITHOUT CLAIM TO ANY PARTICULAR FONT, STYLE, SIZE, OR COLOR.

FOR ON-LINE SOCIAL NETWORKING SERVICES (U.S. CLS. 100 AND 101).

STEVEN PEREZ, EXAMINING ATTORNEY

CLASS 45—(Continued).

SN 77-938,372. WEB SHERIFF LTD., PEWSEY, WILTSHIRE, UNITED KINGDOM, FILED 2-18-2010.



OWNER OF UNITED KINGDOM REG. NO. 2486630, DATED 5-2-2008, EXPIRES 5-2-2018.

NO CLAIM IS MADE TO THE EXCLUSIVE RIGHT TO USE "WEB" AND "PROTECTING YOUR RIGHTS ON THE INTERNET", APART FROM THE MARK AS SHOWN.

THE COLOR(S) GOLD IS/ARE CLAIMED AS A FEATURE OF THE MARK.

THE MARK CONSISTS OF THE WORDING "WEB SHERIFF" EMBEDDED IN A FIVE POINT STAR RESEMBLING A POLICE BADGE. THE STAR IS ENCOMPASSED BY A CIRCLE AND THE WORDING "PROTECTING YOUR RIGHTS" APPEARS IN THE TOP OF THE CIRCLE WITH A STAR ON THE LEFT SIDE OF "PROTECTING" AND ANOTHER STAR ON THE RIGHT SIDE OF "RIGHTS". IN THE BOTTOM OF THE CIRCLE THE WORDING "ON THE INTERNET" APPEARS WITH A STAR ON THE LEFT SIDE OF "ON" AND A STAR ON THE RIGHT SIDE OF "INTERNET". THE ENTIRE MARK IS IN VARIOUS SHADES OF THE COLOR GOLD.

FOR LEGAL CONSULTING SERVICES IN THE FIELDS OF ENTERTAINMENT, INTERNET, RIGHT OF PUBLICITY, INTELLECTUAL PROPERTY, TAKE DOWN NOTIFICATIONS AND ONLINE ANTI-PIRACY INVESTIGATIONS; ALL RELATING TO THE INTERNET (U.S. CLS. 100 AND 101).

CORY BOONE, EXAMINING ATTORNEY

SN 85-058,571. HOME INSTEAD, INC., OMAHA, NE. FILED 6-9-2010.

WELCOME HOME

THE MARK CONSISTS OF STANDARD CHARACTERS WITHOUT CLAIM TO ANY PARTICULAR FONT, STYLE, SIZE, OR COLOR.

FOR PROVIDING CARE ASSISTANCE OF ACTIVITIES OF DAILY LIVING FOR SENIOR CITIZENS IN THEIR RESIDENCES; SOCIAL SERVICES, NAMELY, COMPANIONSHIP SERVICES FOR SENIOR CITIZENS (U.S. CLS. 100 AND 101).

KELLY TRUSILO, EXAMINING ATTORNEY

CLASS 45—(Continued).

SN 85-065,349. TRIPLE CANOPY, INC., HERNDON, VA. FILED 6-17-2010.

ASSESS AVERT ACHIEVE

THE MARK CONSISTS OF STANDARD CHARACTERS WITHOUT CLAIM TO ANY PARTICULAR FONT, STYLE, SIZE, OR COLOR.

FOR GUARD SERVICES, NAMELY, GUARDING GOVERNMENTAL, NONGOVERNMENTAL, MILITARY AND COMMERCIAL FACILITIES; GUARDING INDIVIDUALS, VEHICLE CONVOYS, FIXED FACILITIES AND WORK SITES; SECURITY ASSESSMENT SERVICES, NAMELY, PROVIDING SECURITY ASSESSMENTS OF PHYSICAL LOCATIONS, INFORMATION SYSTEMS AND WORKING ENVIRONMENTS; MILITARY SCIENCE SERVICES, NAMELY, ANALYSIS OF WAR STRATEGIES AND MILITARY OPERATION REQUIREMENTS; SECURITY SERVICES, NAMELY, EMERGENCY AND CRISIS RESPONSE (U.S. CLS. 100 AND 101).

SUSAN RICHARDS, EXAMINING ATTORNEY

SN 85-071,402. THE REINA TRUST BUILDING INSTITUTE INC, STOWE, VT. FILED 6-25-2010.

REBUILDING TRUST

THE MARK CONSISTS OF STANDARD CHARACTERS WITHOUT CLAIM TO ANY PARTICULAR FONT, STYLE, SIZE, OR COLOR.

OWNER OF U.S. REG. NO. 2,712,819.

FOR COUNSELING IN THE FIELD OF PERSONAL DEVELOPMENT, NAMELY, SELF-IMPROVEMENT, SELF-FULFILLMENT, AND INTERPERSONAL COMMUNICATION IN CONNECTION WITH TRUST AND BETRAYAL (U.S. CLS. 100 AND 101).

FIRST USE 12-1-1999; IN COMMERCE 12-1-1999.

ELI HELLMAN, EXAMINING ATTORNEY

SN 85-114,189. REDEEMING TREASURES MINISTRY, RUSTBURG, VA. FILED 8-24-2010.

Abuse Survivors Anonymous

THE MARK CONSISTS OF STANDARD CHARACTERS WITHOUT CLAIM TO ANY PARTICULAR FONT, STYLE, SIZE, OR COLOR.

NO CLAIM IS MADE TO THE EXCLUSIVE RIGHT TO USE "ABUSE SURVIVORS", APART FROM THE MARK AS SHOWN.

FOR ORGANIZING AND CONDUCTING SUPPORT GROUPS IN THE FIELD OF ABUSE AND NEGLECT (U.S. CLS. 100 AND 101).

FIRST USE 7-10-2010; IN COMMERCE 8-23-2010.

ANNE E. GUSTASON, EXAMINING ATTORNEY

CLASS 45—(Continued).

SN 85-118,276. WENDY FELDMAN, LOS ANGELES, CA.
FILED 8-30-2010.

Incarcervention

THE MARK CONSISTS OF STANDARD CHARACTERS WITHOUT CLAIM TO ANY PARTICULAR FONT, STYLE, SIZE, OR COLOR.

FOR LEGAL SERVICES (U.S. CLS. 100 AND 101).
FIRST USE 8-16-2010; IN COMMERCE 8-16-2010.
MICHELE SWAIN, EXAMINING ATTORNEY

SN 85-122,048. PATROL SERVICES INTERNATIONAL LLC,
BEND, OR. FILED 9-2-2010.



NO CLAIM IS MADE TO THE EXCLUSIVE RIGHT TO USE "PATROL SERVICES INTERNATIONAL", APART FROM THE MARK AS SHOWN.

THE COLOR(S) YELLOW, BLUE, BLACK, AND GRAY IS/ARE CLAIMED AS A FEATURE OF THE MARK.

THE MARK CONSISTS OF AN OUTER CONCENTRIC BLACK AND GRAY RING HAVING THE YELLOW AND BLACK OUTLINED WORDS "PATROL SERVICES INTERNATIONAL" ABOVE FIVE YELLOW AND BLACK OUTLINED STARS THAT SEPARATE TWO OPPOSING GRAY AND BLACK OUTLINED LEAFED BRANCHES, AND AN INNER CENTRAL BLUE STAR TOUCHING THE CONCENTRIC BLACK AND GRAY RING, EACH TIP OF THE STAR HAVING A SMALL TERMINAL CIRCLE AND THREE ELONGATED TEAR DROP SHAPES AND THE CENTER OF THE STAR HAVING THE YELLOW AND BLACK OUTLINED LETTERS "PSI" SURROUNDED BY A BLACK AND GRAY CONCENTRIC RING WITH SERRATIONS ALONG ITS INNER SURFACE.

FOR MOBILE SECURITY PATROL SERVICES; ON SITE SECURITY SERVICES; PRIVATE PROPERTY TRAFFIC AND PARKING ENFORCEMENT SERVICES; PERSONAL PROTECTIVE SERVICES (U.S. CLS. 100 AND 101).

JOHN WILKE, EXAMINING ATTORNEY

CLASS 45—(Continued).

SN 85-136,349. GUNSTER, YOAKLEY & STEWART, P.A.,
WEST PALM BEACH, FL. FILED 9-23-2010.



OWNER OF U.S. REG. NO. 3,801,828.
NO CLAIM IS MADE TO THE EXCLUSIVE RIGHT TO USE "FLORIDA'S LAW FIRM FOR BUSINESS", APART FROM THE MARK AS SHOWN.

THE MARK CONSISTS OF A STYLIZED LETTER "G" SITUATED INSIDE A SQUARE DESIGN AND THE WORD "GUNSTER" SITUATED ABOVE THE WORDS "FLORIDA'S LAW FIRM FOR BUSINESS".

FOR LEGAL SERVICES (U.S. CLS. 100 AND 101).
FIRST USE 3-1-2009; IN COMMERCE 3-1-2009.
MAUREEN DALL, EXAMINING ATTORNEY

SN 85-214,205. THE LAW OFFICES OF MICHAEL B. BREHNE, PA. ALTAMONTE SPRINGS, FL. FILED S.R. 1-10-2011; AM. P.R. 6-23-2011.



NO CLAIM IS MADE TO THE EXCLUSIVE RIGHT TO USE "MOTORCYCLE ATTORNEYS", APART FROM THE MARK AS SHOWN.

THE COLOR(S) ORANGE AND BLACK IS/ARE CLAIMED AS A FEATURE OF THE MARK.

THE MARK CONSISTS OF THE TERMS "MOTORCYCLE ATTORNEYS" IN BLACK, ABOVE A FLAME DESIGN IN SHADES OF ORANGE, OUTLINED IN BLACK, ABOVE THE TERM "WWW.911BIKERLAW.COM" IN BLACK.

FOR ATTORNEY SERVICES (U.S. CLS. 100 AND 101).
FIRST USE 9-25-2010; IN COMMERCE 9-25-2010.
HELENE LIWINSKI, EXAMINING ATTORNEY

CLASS 45—(Continued).

SN 85-214,220. THE LAW OFFICES OF MICHAEL B. BREHNE, PA, ALTAMONTE SPRINGS, FL. FILED S.R. 1-10-2011; AM. P.R. 6-23-2011.

911 Biker Law

THE MARK CONSISTS OF STANDARD CHARACTERS WITHOUT CLAIM TO ANY PARTICULAR FONT, STYLE, SIZE, OR COLOR.

NO CLAIM IS MADE TO THE EXCLUSIVE RIGHT TO USE "BIKER LAW", APART FROM THE MARK AS SHOWN. FOR ATTORNEY SERVICES (U.S. CLS. 100 AND 101). FIRST USE 9-25-2010; IN COMMERCE 9-25-2010. HELENE LIWINSKI, EXAMINING ATTORNEY

SN 85-214,933. ARCHDIOCESE OF MIAMI, INC., MIAMI SHORES, FL. FILED 1-11-2011.

ARCHDIOCESE OF MIAMI

THE MARK CONSISTS OF STANDARD CHARACTERS WITHOUT CLAIM TO ANY PARTICULAR FONT, STYLE, SIZE, OR COLOR.

SEC. 2(F). FOR RELIGIOUS AND SPIRITUAL SERVICES, NAMELY, CONDUCTING RELIGIOUS WORSHIP, MARRIAGE CEREMONIES, BAPTISMAL CEREMONIES, BABY DEDICATIONS, BEREAVEMENT CEREMONIES, AND RELIGIOUS COUNSELING (U.S. CLS. 100 AND 101).

FIRST USE 5-8-1968; IN COMMERCE 1-1-1980. BARBARA RUTLAND, EXAMINING ATTORNEY

CLASS 45—(Continued).

SN 85-237,086. E.J. CONFIDENTIAL, INC., DBA MARRY-MEYESTERDAY.COM, DETROIT, MI. FILED 2-8-2011.



THE MARK CONSISTS OF THE FOLLOWING: A HEART DESIGN WITH A TOP HAT INSIDE OF IT, CURVED BANDS AROUND THE HEART DESIGN, THE WORDING "MARRY ME YESTERDAY.COM" WITH THE WORDING "MARRY ME" APPEARING ABOVE THE WORDING "YESTERDAY.COM", ROSES AND CURVED BANDS THAT APPEAR ON EACH SIDE OF THE WORDING, A DIAMOND RING, AND A PLAIN RING.

FOR COMPUTER DATING SERVICES; DATING SERVICES; DATING SERVICES, NAMELY, PROVIDING AN ON-LINE COMPUTER DATABASE FEATURING SINGLE PEOPLE INTERESTED IN MEETING OTHER SINGLE PEOPLE; INTERNET BASED SOCIAL NETWORKING, INTRODUCTION, AND DATING SERVICES; INTERNET-BASED DATING, SOCIAL INTRODUCTION AND SOCIAL NETWORKING SERVICES; MARRIAGE PARTNER INTRODUCTION OR DATING SERVICES; MATCHMAKING SERVICES (U.S. CLS. 100 AND 101).

SETH A. RAPPAPORT, EXAMINING ATTORNEY

SN 85-242,429. HAMMOND, CHARLES, SAN FRANCISCO, CA. FILED 2-15-2011.

Live Well. Get Organized!

THE MARK CONSISTS OF STANDARD CHARACTERS WITHOUT CLAIM TO ANY PARTICULAR FONT, STYLE, SIZE, OR COLOR.

FOR PROFESSIONAL HOME ORGANIZING SERVICES, NAMELY, PHYSICAL ORGANIZATION OF HOMES (U.S. CLS. 100 AND 101).

FIRST USE 7-1-2010; IN COMMERCE 7-1-2010. REBECCA SMITH, EXAMINING ATTORNEY

CLASS 45—(Continued).

SN 85-258,357. THE METROPOLITAN COMMUNITY CHURCH OF SAN DIEGO, SAN DIEGO, CA. FILED 3-4-2011.

THE METROPOLITAN COMMUNITY
CHURCH OF SAN DIEGO

THE MARK CONSISTS OF STANDARD CHARACTERS WITHOUT CLAIM TO ANY PARTICULAR FONT, STYLE, SIZE, OR COLOR.

NO CLAIM IS MADE TO THE EXCLUSIVE RIGHT TO USE "COMMUNITY CHURCH", APART FROM THE MARK AS SHOWN.

SEC. 2(F).

FOR RELIGIOUS AND SPIRITUAL SERVICES, NAMELY, CONDUCTING RELIGIOUS WORSHIP, MARRIAGE CEREMONIES, BAPTISMAL CEREMONIES, BABY DEDICATIONS, BEREAVEMENT CEREMONIES, AND RELIGIOUS COUNSELING (U.S. CLS. 100 AND 101).

FIRST USE 6-0-1970; IN COMMERCE 6-0-1970.
CORY BOONE, EXAMINING ATTORNEY

CLASS 45—(Continued).

SN 85-267,468. PLISZKA, JODI A., MUSKEGO, WI. FILED 3-15-2011.

THE SOLUTIONOLOGIST

THE MARK CONSISTS OF STANDARD CHARACTERS WITHOUT CLAIM TO ANY PARTICULAR FONT, STYLE, SIZE, OR COLOR.

FOR PERSONAL GROWTH AND MOTIVATION CONSULTING SERVICES (U.S. CLS. 100 AND 101).

FIRST USE 1-1-2011; IN COMMERCE 2-1-2011.
EUGENIA MARTIN, EXAMINING ATTORNEY

SN 85-264,547. THATCHER'S FUNERAL HOME, INC., KANSAS CITY, KS. FILED 3-11-2011.



NO CLAIM IS MADE TO THE EXCLUSIVE RIGHT TO USE "FUNERAL HOME", APART FROM THE MARK AS SHOWN.

THE MARK CONSISTS OF THE WORDS "THATCHER'S FUNERAL HOME" ADJACENT TO A STYLIZED DOVE WITHIN IN CIRCULAR DESIGN.

FOR FUNERAL ARRANGEMENT SERVICES, FUNERAL HOME SERVICES, FUNERAL SERVICE UNDERTAKING, FUNERAL SERVICES ACCOMPANYING CREMATION, AND INTERMENT SERVICES (U.S. CLS. 100 AND 101).

FIRST USE 3-1-2008, THE MARK WAS FIRST USED ANYWHERE IN A DIFFERENT FORM OTHER THAN THAT SOUGHT TO BE REGISTERED AT LEAST AS EARLY AS 01/01/1964.; IN COMMERCE 3-1-2008, THE MARK WAS FIRST USED IN COMMERCE IN A DIFFERENT FORM OTHER THAN THAT SOUGHT TO BE REGISTERED AT LEAST AS EARLY AS 01/01/1964..

KATHERINE STOIDES, EXAMINING ATTORNEY

SN 85-267,508. MISCOE HEALTH LAW, LLC, CENTRAL CITY, PA. FILED 3-15-2011.



NO CLAIM IS MADE TO THE EXCLUSIVE RIGHT TO USE "HEALTHCARE AUDIT RESPONSE TEAM" AND THE REPRESENTATION OF THE CADUCEUS, APART FROM THE MARK AS SHOWN.

THE COLOR(S) ORANGE, WHITE, BLACK AND TAN IS/ARE CLAIMED AS A FEATURE OF THE MARK.

THE MARK CONSISTS OF THE WORDING "HART HEALTHCARE AUDIT RESPONSE TEAM" WITH "HART" IN ORANGE WITH BLACK AND WHITE OUTLINING, "HEALTHCARE AUDIT" IN BLACK, AND "RESPONSE TEAM" IN TAN, AND THE DESIGN OF A BLACK CADUCEUS HOLDING TAN SCALES OF JUSTICE APPEARING INSIDE OF AN ORANGE HEART SURROUNDED BY A LARGER HEART IN TAN WITH A WHITE BACKGROUND.

FOR LEGAL SERVICES (U.S. CLS. 100 AND 101).

FIRST USE 1-1-2010; IN COMMERCE 1-1-2010.
SEAN CROWLEY, EXAMINING ATTORNEY

CLASS 45—(Continued).

SN 85-268,676. FAM INTERNATIONAL LOGISTICS, INC., DAVIE, FL. FILED 3-16-2011.



NO CLAIM IS MADE TO THE EXCLUSIVE RIGHT TO USE "THE GEOGRAPHIC REPRESENTATION OF THE EARTH AND CONTINENTS", APART FROM THE MARK AS SHOWN.

THE COLOR(S) BLUE, WHITE AND GRAY IS/ARE CLAIMED AS A FEATURE OF THE MARK.

THE MARK CONSISTS OF THE LETTERS "FAM" IN WHITE, CAPITAL LETTERS CONTAINED WITHIN A BLUE RECTANGLE ABOVE A BLUE SHIELD SHAPE CONTAINING A PORTION OF A GLOBE DEPICTING THE EARTH AND SURROUNDED BY A GRAY LINE.

FOR BACKGROUND INVESTIGATION AND RESEARCH SERVICES; MONITORING OF SECURITY SYSTEMS; PERSONAL SECURITY CONSULTATION; PROVIDING A WEB SITE FEATURING INFORMATION IN THE FIELD OF SECURITY; SECURITY CONSULTANCY; SECURITY GUARD SERVICES; SECURITY GUARDING FOR FACILITIES; SECURITY SERVICES FOR INDIVIDUALS AND BUSINESS PERSONS TRAVELING INTERNATIONALLY AND DOMESTICALLY, NAMELY, PROVIDING FOREIGN COUNTRY SECURITY BRIEFINGS, EMBASSY INFORMATION FOR SECURITY PURPOSES AND SECURITY REPORTS; SECURITY SERVICES, NAMELY, PROVIDING EXECUTIVE PROTECTION; SECURITY SERVICES, NAMELY, PROVIDING SECURITY ASSESSMENTS FOR BUSINESSES AND GOVERNMENTAL AGENCIES; SECURITY SERVICES, NAMELY, PROVIDING SECURITY ASSESSMENTS OF PHYSICAL LOCATIONS, INFORMATION SYSTEMS, AND WORKING ENVIRONMENTS (U.S. CLS. 100 AND 101).

FIRST USE 3-9-1998; IN COMMERCE 3-9-1998.
ERIN FALK, EXAMINING ATTORNEY

SN 85-269,478. GA200 LLC, LOS ANGELES, CA. FILED 3-17-2011.



THE MARK CONSISTS OF THE NUMBER "2" WITH A SHADOW UNDERNEATH.
FOR ON-LINE SOCIAL NETWORKING SERVICES (U.S. CLS. 100 AND 101).

MICHAEL KEATING, EXAMINING ATTORNEY

CLASS 45—(Continued).

SN 85-269,484. GA200 LLC, LOS ANGELES, CA. FILED 3-17-2011.



THE MARK CONSISTS OF THE TERM "GA200" IN STYLIZED LETTERS WITH A SHADOW UNDERNEATH.
FOR ON-LINE SOCIAL NETWORKING SERVICES (U.S. CLS. 100 AND 101).

MICHAEL KEATING, EXAMINING ATTORNEY

SN 85-269,840. IRWIN DEBORAH, DBA ANCESTRAL ATTIC, CARP LAKE, MI. FILED 3-17-2011.

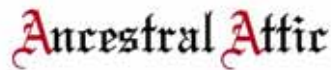

NO CLAIM IS MADE TO THE EXCLUSIVE RIGHT TO USE "ANCESTRAL", APART FROM THE MARK AS SHOWN.

THE COLOR(S) DARK RED AND BLACK IS/ARE CLAIMED AS A FEATURE OF THE MARK.

THE MARK CONSISTS OF "ANCESTRAL ATTIC" IN STYLIZED FONT WITH FIRST LETTER OF EACH WORD IN DARK RED AND REMAINING LETTERS IN BLACK.

FOR GENEALOGY RESEARCH (U.S. CLS. 100 AND 101).

FIRST USE 1-12-2004; IN COMMERCE 1-12-2004.
CHERYL CLAYTON, EXAMINING ATTORNEY

SN 85-270,341. TANYA MITCHELL GRAHAM, STONE MOUNTAIN, GA. FILED 3-18-2011.

Gold Digger Killer

THE MARK CONSISTS OF STANDARD CHARACTERS WITHOUT CLAIM TO ANY PARTICULAR FONT, STYLE, SIZE, OR COLOR.

NO CLAIM IS MADE TO THE EXCLUSIVE RIGHT TO USE "GOLD DIGGER", APART FROM THE MARK AS SHOWN.

FOR ATTORNEY SERVICES (U.S. CLS. 100 AND 101).
FIRST USE 1-1-2011; IN COMMERCE 1-1-2011.

APRIL HESIK, EXAMINING ATTORNEY

CLASS 45—(Continued).

SN 85-270,497. CHARLOTTE CARE SERVICES, INC., AKA CHARLOTTE CARE SERVICES, INC./GRANDMOTHERS, INC., CHARLOTTE, NC. FILED 3-18-2011.

**Charlotte Care Services,
Inc.
Because it's family.**

THE MARK CONSISTS OF STANDARD CHARACTERS WITHOUT CLAIM TO ANY PARTICULAR FONT, STYLE, SIZE, OR COLOR.

NO CLAIM IS MADE TO THE EXCLUSIVE RIGHT TO USE "CHARLOTTE CARE SERVICES, INC.", APART FROM THE MARK AS SHOWN.

FOR BABYSITTING SERVICES; IN-HOME SUPPORT SERVICES TO SENIOR PERSONS, NAMELY, GERIATRIC CARE MANAGEMENT SERVICES IN THE NATURE OF THE COORDINATION OF NECESSARY SERVICES AND PERSONAL CARE FOR OLDER INDIVIDUALS; PERSONAL CARE ASSISTANCE OF ACTIVITIES OF DAILY LIVING, SUCH AS BATHING, GROOMING AND PERSONAL MOBILITY FOR MENTALLY OR PHYSICALLY CHALLENGED PEOPLE; PET SITTING (U.S. CLS. 100 AND 101).

FIRST USE 3-1-2010; IN COMMERCE 3-1-2010.
SEAN CROWLEY, EXAMINING ATTORNEY

SN 85-270,802. KONKLER, EDWARD, LANCASTER, OH. FILED 3-18-2011.

CENTRAL OHIO GHOST SQUAD

THE MARK CONSISTS OF STANDARD CHARACTERS WITHOUT CLAIM TO ANY PARTICULAR FONT, STYLE, SIZE, OR COLOR.

NO CLAIM IS MADE TO THE EXCLUSIVE RIGHT TO USE "CENTRAL OHIO GHOST", APART FROM THE MARK AS SHOWN.

FOR PARANORMAL INVESTIGATION SERVICES (U.S. CLS. 100 AND 101).

FIRST USE 4-0-2006; IN COMMERCE 4-0-2006.
PATRICIA EVANKO, EXAMINING ATTORNEY

SN 85-273,006. WEISS, JODY REISA, NEW YORK, NY. FILED 3-22-2011.

Wikiethics

THE MARK CONSISTS OF STANDARD CHARACTERS WITHOUT CLAIM TO ANY PARTICULAR FONT, STYLE, SIZE, OR COLOR.

FOR SOCIAL NETWORKING SERVICES IN THE FIELD OF MORAL ETHICS PROVIDED VIA A WEBSITE (U.S. CLS. 100 AND 101).

EVELYN BRADLEY, EXAMINING ATTORNEY

CLASS 45—(Continued).

SN 85-273,819. MISSERI, ROBERT, GARDEN CITY, NY. FILED 3-22-2011.

THE PI HOTLINE

THE MARK CONSISTS OF STANDARD CHARACTERS WITHOUT CLAIM TO ANY PARTICULAR FONT, STYLE, SIZE, OR COLOR.

NO CLAIM IS MADE TO THE EXCLUSIVE RIGHT TO USE "PI", APART FROM THE MARK AS SHOWN.

FOR BACKGROUND INVESTIGATION AND RESEARCH SERVICES; BACKGROUND INVESTIGATION SERVICES; DETECTIVE INVESTIGATIONS; INFIDELITY INVESTIGATION SERVICES IN THE FIELD OF PERSONAL RELATIONSHIPS; INVESTIGATING INTO MISSING PERSONS; INVESTIGATION OF ASSETS, CREDIT REPORTS, FISCAL ASSESSMENTS, AND COLLECTION REPORTS FOR SECURITY OR AUTHENTICATION PURPOSES (U.S. CLS. 100 AND 101).

MELISSA VALLILLO, EXAMINING ATTORNEY

SN 85-274,009. DENNIS DONAHUE & ASSOCIATES, LLC, ST. LOUIS, MO. FILED 3-22-2011.

PATENTS ON THE BEACH

THE MARK CONSISTS OF STANDARD CHARACTERS WITHOUT CLAIM TO ANY PARTICULAR FONT, STYLE, SIZE, OR COLOR.

NO CLAIM IS MADE TO THE EXCLUSIVE RIGHT TO USE "PATENTS", APART FROM THE MARK AS SHOWN.

FOR CONSULTING IN THE FIELD OF INTELLECTUAL PROPERTY LICENSING; LICENSING OF COMPUTER SOFTWARE; LICENSING OF INTELLECTUAL PROPERTY; LICENSING OF TRADEMARKS; PATENT LICENSING (U.S. CLS. 100 AND 101).

JOSETTE BEVERLY, EXAMINING ATTORNEY

SN 85-274,523. FILE RIGHT LLC, MIDDLETOWN, DE. FILED 3-23-2011.



THE MARK CONSISTS OF CHECK MARK ON TOP OF THREE STACKED SHADOWED BOXES FOLLOWED BY THE WORDS "FILERIGHT".

FOR PROVIDING A WEBSITE FEATURING GENERAL IMMIGRATION-RELATED LEGAL INFORMATION VIA A WEBSITE ON GLOBAL COMPUTER NETWORKS (U.S. CLS. 100 AND 101).

DEIRDRE ROBERTSON, EXAMINING ATTORNEY

CLASS 45—(Continued).

SN 85-274,543. FILE RIGHT LLC, MIDDLETOWN, DE.
FILED 3-23-2011.



THE MARK CONSISTS OF CHECK MARK ON TOP OF THREE STACKED SHADOWED BOXES FOLLOWED BY THE WORDS "FILERIGHT".

FOR LEGAL DOCUMENT PREPARATION SERVICES AND PROVIDING GENERAL IMMIGRATION-RELATED LEGAL INFORMATION VIA A WEBSITE ON GLOBAL COMPUTER NETWORKS (U.S. CLS. 100 AND 101).

DEIRDRE ROBERTSON, EXAMINING ATTORNEY

CLASS 45—(Continued).

SN 85-275,317. MONTAGE COMMUNICATIONS GROUP, INC., GURNEE, IL. FILED 3-24-2011.



NO CLAIM IS MADE TO THE EXCLUSIVE RIGHT TO USE "BRAZILCLUB", APART FROM THE MARK AS SHOWN.

THE COLOR(S) BLUE, WHITE, BLACK, BROWN, YELLOW AND GREEN IS/ARE CLAIMED AS A FEATURE OF THE MARK.

THE MARK CONSISTS OF "BRAZILCLUB" IN BLACK STYLIZED LETTERS; BELOW THIS IS A SHIELD OUTLINED IN BLACK, THE TOP PORTION HAS A YELLOW BACKGROUND AND THE BOTTOM A BLUE; IN THE MIDDLE IS A WHITE AND BLACK OUTLINED BANNER WITH THE WORDS "SUN STYLE SAMBA" IN BLACK STYLIZED LETTERS; THE TOP PORTION HAS BROWN AND GREEN PALM TREES AND THE BOTTOM HAS WHITE STARS.

FOR ON-LINE SOCIAL NETWORKING SERVICES (U.S. CLS. 100 AND 101).

FIRST USE 5-28-2010; IN COMMERCE 5-28-2010.

REBECCA POVARCHUK, EXAMINING ATTORNEY

SN 85-275,308. ROBINSON, STEVE, LEXINGTON, KY.
FILED 3-24-2011.

DOG FETCHER

THE MARK CONSISTS OF STANDARD CHARACTERS WITHOUT CLAIM TO ANY PARTICULAR FONT, STYLE, SIZE, OR COLOR.

NO CLAIM IS MADE TO THE EXCLUSIVE RIGHT TO USE "DOG", APART FROM THE MARK AS SHOWN.

FOR ASSISTANCE IN LOCATING LOST DOGS (U.S. CLS. 100 AND 101).

BARBARA GAYNOR, EXAMINING ATTORNEY

SN 85-276,672. PONDER, TRACIE DEAN, STUDIO CITY, CA.
FILED S.R. 3-25-2011; AM. P.R. 6-28-2011.

Genius In Motion

THE MARK CONSISTS OF STANDARD CHARACTERS WITHOUT CLAIM TO ANY PARTICULAR FONT, STYLE, SIZE, OR COLOR.

FOR ONLINE SOCIAL NETWORKING SERVICES PROVIDED THROUGH A COMMUNITY WEBSITE (U.S. CLS. 100 AND 101).

FIRST USE 1-1-2004; IN COMMERCE 3-1-2004.

EDWARD NELSON, EXAMINING ATTORNEY

CLASS 45—(Continued).

SN 85-277,819. MARTIN, RICHARD Z., RIVERBANK, CA.
FILED 3-26-2011.

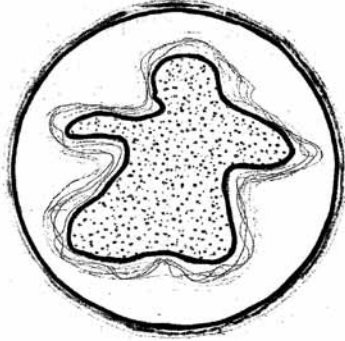

FOR PROVIDING INFORMATION IN THE FIELD OF
RELIGIOUS AND SPIRITUAL BELIEF SYSTEMS (U.S.
CLS. 100 AND 101).

DAVID TOOLEY, EXAMINING ATTORNEY

SN 85-278,331. BARRETT & FARAHANY, LLP, ATLANTA,
GA. FILED 3-28-2011.

Justice at Work

THE MARK CONSISTS OF STANDARD CHARACTERS
WITHOUT CLAIM TO ANY PARTICULAR FONT, STYLE,
SIZE, OR COLOR.

FOR LEGAL SERVICES, NAMELY, PROVIDING CUSTOMIZED
INFORMATION, COUNSELING, ADVICE
AND LITIGATION SERVICES IN ALL AREAS OF
EMPLOYMENT AND LABOR LAW FOR BOTH EMPLOYEES
AND EMPLOYERS (U.S. CLS. 100 AND 101).

FIRST USE 4-1-2009; IN COMMERCE 4-1-2009.
LAURIE MAYES, EXAMINING ATTORNEY

CLASS 45—(Continued).

SN 85-279,809. HADDAD, JOSEPH, CANYON COUNTRY,
CA. FILED 3-29-2011.



NO CLAIM IS MADE TO THE EXCLUSIVE RIGHT TO
USE "THE ULTIMATE IN EROTIC PLEASURE", APART
FROM THE MARK AS SHOWN.

THE MARK CONSISTS OF THE STYLIZED WORDING
"OSIRISEROTIC" APPEARING OVER THE PHRASE "THE
ULTIMATE IN EROTIC PLEASURE.". AN IMAGE OF A
FIGURE WITH HORNS, SPECIFICALLY THE EGYPTIAN
GODDESS OSIRIS, INSIDE A CIRCLE APPEARS TO THE
LEFT OF THE TEXT.

FOR ESCORT SERVICES (U.S. CLS. 100 AND 101).

FIRST USE 3-1-2011; IN COMMERCE 3-1-2011.

ALYSSA STEEL, EXAMINING ATTORNEY

SN 85-285,793. THE SHINE FACTOR, LONGMONT, CO.
FILED 4-4-2011.

The SHINE Factor

THE MARK CONSISTS OF STANDARD CHARACTERS
WITHOUT CLAIM TO ANY PARTICULAR FONT, STYLE,
SIZE, OR COLOR.

FOR EDUCATIONAL SERVICES, NAMELY, PERSONAL
COACHING AND MENTORING FOR WOMEN IN
THE FIELD OF PERSONAL GROWTH INTUITIVE
COACHING (U.S. CLS. 100 AND 101).

FIRST USE 1-1-2009; IN COMMERCE 1-1-2009.

NAKIA HENRY, EXAMINING ATTORNEY

SN 85-286,216. SHARPE, VIRGINIA D., DELAND, FL. FILED
4-5-2011.

Tres Arroyos

THE MARK CONSISTS OF STANDARD CHARACTERS
WITHOUT CLAIM TO ANY PARTICULAR FONT, STYLE,
SIZE, OR COLOR.

THE ENGLISH TRANSLATION OF "TRES ARROYOS" IS
"THREE STREAMS".

FOR MINISTERIAL SERVICES, NAMELY, HOLDING
SPIRITUAL RETREATS TO ASSIST RELIGIOUS LEADERS,
BOTH CLERGY AND LAY, TO DEVELOP AND
ENHANCE THEIR SPIRITUAL LIVES (U.S. CLS. 100
AND 101).

FIRST USE 8-8-2009; IN COMMERCE 2-18-2010.

DAVID COLLIER, EXAMINING ATTORNEY

CLASS 45—(Continued).

SN 85-287,672. ELEMBAZY, HAITHAM I, WEST HARRISON, NY. FILED 4-6-2011.

BubbleBuzz

THE MARK CONSISTS OF STANDARD CHARACTERS WITHOUT CLAIM TO ANY PARTICULAR FONT, STYLE, SIZE, OR COLOR.

FOR ONLINE SOCIAL NETWORKING SERVICES PROVIDED THROUGH A COMMUNITY WEBSITE (U.S. CLS. 100 AND 101).

BRENDAN REGAN, EXAMINING ATTORNEY

SN 85-288,223. PIPER, JACQUELINE P, DALLAS, TX. FILED 4-6-2011.

Image On The GO!

THE MARK CONSISTS OF STANDARD CHARACTERS WITHOUT CLAIM TO ANY PARTICULAR FONT, STYLE, SIZE, OR COLOR.

FOR FASHION CONSULTING SERVICES; FASHION INFORMATION; FASHION TREND CONSULTING FOR THE FASHION INDUSTRY; FASHION TREND CONSULTING SERVICES; PERSONAL FASHION CONSULTING SERVICES; PERSONAL GROWTH AND MOTIVATION CONSULTING SERVICES; PERSONAL IMAGE CONSULTING SERVICES; PERSONAL IMAGE DEVELOPMENT CONSULTATION; PERSONAL LIFESTYLE CONSULTING SERVICES; PERSONAL STYLIST SERVICES, NAMELY, EVALUATING THE PHYSICAL ATTRIBUTES, LIFESTYLE, AND FASHION STYLES OF OTHERS AND RECOMMENDING CLOTHING AND ACCESSORIES TO ACHIEVE THE PERSONAL IMAGE DESIRED BY THE CLIENT; PROVIDING A WEB SITE FEATURING INFORMATION AND CONTENT IN THE FIELDS OF PERSONAL RELATIONSHIPS, DATING AND FASHION; PROVIDING FASHION INFORMATION; PROVIDING FASHION INFORMATION IN THE FIELD OF DURABILITY, FIT AND STYLE OF LINGERIE PRODUCTS VIA THE INTERNET; PROVIDING INFORMATION ABOUT FASHION; PROVIDING INFORMATION IN THE FIELD OF FASHION TRENDS; PROVIDING NEWS AND INFORMATION IN THE FIELD OF FASHION; PROVIDING ONLINE FASHION QUESTIONS TO HELP USERS DETERMINE THE STYLE OF CLOTHING BEST SUITED TO THEIR INDIVIDUAL NEEDS AND PREFERENCES; PROVISION OF A WEB SITE FEATURING INFORMATION ON FASHION (U.S. CLS. 100 AND 101).

FIRST USE 4-11-2010; IN COMMERCE 4-11-2010.
REBECCA SMITH, EXAMINING ATTORNEY

CLASS 45—(Continued).

SN 85-288,503. SPECTRUM TRACKING SYSTEMS, INC., CARROLLTON, TX. FILED 4-7-2011.

SPECTRUM TRACKING SYSTEMS

THE MARK CONSISTS OF STANDARD CHARACTERS WITHOUT CLAIM TO ANY PARTICULAR FONT, STYLE, SIZE, OR COLOR.

NO CLAIM IS MADE TO THE EXCLUSIVE RIGHT TO USE "TRACKING SYSTEMS", APART FROM THE MARK AS SHOWN.

FOR LICENSING INTELLECTUAL PROPERTY IN THE FIELD OF LOCATION TRACKING (U.S. CLS. 100 AND 101).

JESSICA A. POWERS, EXAMINING ATTORNEY

SN 85-288,530. SPECTRUM TRACKING SYSTEMS, INC., CARROLLTON, TX. FILED 4-7-2011.



OWNER OF U.S. REG. NOS. 2,765,195, 2,800,661 AND OTHERS.

NO CLAIM IS MADE TO THE EXCLUSIVE RIGHT TO USE "TRACKING SYSTEMS" OR "MANAGEMENT COMPANY", APART FROM THE MARK AS SHOWN.

THE MARK CONSISTS OF THE WORDS "STS SPECTRUM TRACKING SYSTEMS A SPECTRUM MANAGEMENT COMPANY" WITH A VERTICAL BAR BETWEEN THE LETTERS "S" AND "T" AND A VERTICAL BAR BETWEEN "T" AND "S" IN THE WORD "STS".

FOR LICENSING INTELLECTUAL PROPERTY IN THE FIELD OF LOCATION TRACKING (U.S. CLS. 100 AND 101).

JESSICA A. POWERS, EXAMINING ATTORNEY

SN 85-290,603. GOTTA HAVE SOLE FOUNDATION, INC., CRANSTON, RI. FILED 4-8-2011.

SOLEDIERS

THE MARK CONSISTS OF STANDARD CHARACTERS WITHOUT CLAIM TO ANY PARTICULAR FONT, STYLE, SIZE, OR COLOR.

FOR CHARITABLE SERVICES, NAMELY, PROVIDING SHOES TO NEEDY CHILDREN (U.S. CLS. 100 AND 101).

FIRST USE 3-30-2011; IN COMMERCE 3-30-2011.
MICHELLE DUBOIS, EXAMINING ATTORNEY

CLASS 45—(Continued).

SN 85-290,614. GOTTA HAVE SOLE FOUNDATION, INC.,
CRANSTON, RI. FILED 4-8-2011.

EVERY SOLE HAS A STORY.

THE MARK CONSISTS OF STANDARD CHARACTERS WITHOUT CLAIM TO ANY PARTICULAR FONT, STYLE, SIZE, OR COLOR.

FOR CHARITABLE SERVICES, NAMELY, PROVIDING SHOES TO NEEDY CHILDREN (U.S. CLS. 100 AND 101).

FIRST USE 3-30-2011; IN COMMERCE 3-30-2011.
MICHELLE DUBOIS, EXAMINING ATTORNEY

SN 85-290,675. GOTTA HAVE SOLE FOUNDATION, INC.,
CRANSTON, RI. FILED 4-8-2011.



OWNER OF U.S. REG. NO. 3,860,531.
THE COLOR(S) BLACK, WHITE AND RED IS/ARE CLAIMED AS A FEATURE OF THE MARK.

THE MARK CONSISTS OF A FACSIMILE OF TWO FEET IN BLACK WITH A RED HEART IN THE CENTER THEREOF WITH WHITE RAYS EMANATING OUTWARDLY IN THE FEET FROM THE HEART.

FOR CHARITABLE SERVICES, NAMELY, PROVIDING SHOES TO NEEDY CHILDREN (U.S. CLS. 100 AND 101).

FIRST USE 2-19-2010; IN COMMERCE 2-24-2010.
MICHELLE DUBOIS, EXAMINING ATTORNEY

CLASS 45—(Continued).

SN 85-291,060. WIJERATNE, SUNIL, WOODBRIDGE, NJ.
FILED 4-9-2011.



Platinumrank

THE COLOR(S) BOLD BLUE (COLOR CODE # 0500FF), BOLD PLATINUM COLOR (COLOR CODE # 867866), AND WHITE IS/ARE CLAIMED AS A FEATURE OF THE MARK.

THE MARK CONSISTS OF A SHIELD IN BOLD BLUE (COLOR CODE # 0500FF) OUTLINE WITH WHITE INSIDE AND UPPERCASE LETTER "P" IN BOLD PLATINUM COLOR (COLOR CODE # 867866) INSIDE THE ABOVE MENTIONED SHIELD; UNDER THE SHIELD IS THE WORD "PLATINUMRANK" IN BOLD PLATINUM COLOR (COLOR CODE # 867866) IN ROCKWELL FONT.

FOR PROVIDING ON-LINE SOCIAL NETWORKING SERVICES TO MEMBERS IN THE FIELDS OF MARRIAGE, ESTABLISHING FRIENDSHIPS, MODELING OR PERUSING AN ACTING CAREER BASED ON THE RATING BY OTHER MEMBERS ON A POSTED PICTURE FOR VARIOUS AGE GROUPS, INVESTMENT OPPORTUNITIES, REVIEWS ON PLACES, FOOD AND WINE, CONSUMERS, PRODUCTS AND SERVICES, AND TEMPORARY LOCAL JOB OPPORTUNITIES (U.S. CLS. 100 AND 101).

MAYUR VAGHANI, EXAMINING ATTORNEY

SN 85-291,066. WIJERATNE, SUNIL, WOODBRIDGE, NJ.
FILED 4-9-2011.

for people by people
worldwide

THE MARK CONSISTS OF STANDARD CHARACTERS WITHOUT CLAIM TO ANY PARTICULAR FONT, STYLE, SIZE, OR COLOR.

NO CLAIM IS MADE TO THE EXCLUSIVE RIGHT TO USE "WORLDWIDE", APART FROM THE MARK AS SHOWN.

FOR PROVIDING ON-LINE SOCIAL NETWORKING SERVICES TO MEMBERS IN THE FIELDS OF MARRIAGE, ESTABLISHING FRIENDSHIPS, MODELING OR PERUSING AN ACTING CAREER BASED ON THE RATING BY OTHER MEMBERS ON A POSTED PICTURE FOR VARIOUS AGE GROUPS, INVESTMENT OPPORTUNITIES, REVIEWS ON PLACES, FOOD AND WINE, CONSUMERS, PRODUCTS AND SERVICES, AND TEMPORARY LOCAL JOB OPPORTUNITIES (U.S. CLS. 100 AND 101).

MAYUR VAGHANI, EXAMINING ATTORNEY

CLASS 45—(Continued).

SN 85-291,097. SICON STUDIOS, LLC, EAGLE, ID. FILED 4-9-2011.

maneNation

THE MARK CONSISTS OF STANDARD CHARACTERS WITHOUT CLAIM TO ANY PARTICULAR FONT, STYLE, SIZE, OR COLOR.

FOR ONLINE SOCIAL NETWORKING SERVICES PROVIDED THROUGH A WEBSITE DEVOTED TO HORSES (U.S. CLS. 100 AND 101).

FIRST USE 4-4-2011; IN COMMERCE 4-4-2011.
REBECCA SMITH, EXAMINING ATTORNEY

CLASS 45—(Continued).

SN 85-291,474. ACS, INC, MOUNTAIN VIEW, CA. FILED 4-11-2011.



THE MARK CONSISTS OF A BOOK CONSISTING OF TWO UPRIGHT PARALLELOGRAMS, ONE BEING THE SPINE, AND ONE BEING THE FRONT COVER. THE FRONT COVER CONTAINS THE LETTERS "RB" AND A QUARTER CIRCLE ARC. TO THE RIGHT THERE IS THE STYLIZED TEXT "MYREDBOOK".

FOR ON-LINE SOCIAL NETWORKING SERVICES (U.S. CLS. 100 AND 101).

FIRST USE 6-1-2001; IN COMMERCE 6-1-2001.
KELLEY WELLS, EXAMINING ATTORNEY

SN 85-291,162. HOT IGLOO PRODUCTIONS LIMITED, AKA SHOEPERWOMAN, LIVINGSTON, UNITED KINGDOM, FILED S.R. 4-10-2011; AM. P.R. 7-14-2011.

shoepерwoman

THE MARK CONSISTS OF STANDARD CHARACTERS WITHOUT CLAIM TO ANY PARTICULAR FONT, STYLE, SIZE, OR COLOR.

FOR PROVISION OF A WEB SITE FEATURING INFORMATION ON FASHION (U.S. CLS. 100 AND 101).

FIRST USE 4-23-2009; IN COMMERCE 4-23-2009.
GIANCARLO CASTRO, EXAMINING ATTORNEY

SN 85-291,634. SHARMA, MAN, NEWARK, CA. FILED 4-11-2011.

CHOOOMA

THE MARK CONSISTS OF STANDARD CHARACTERS WITHOUT CLAIM TO ANY PARTICULAR FONT, STYLE, SIZE, OR COLOR.

THE ENGLISH TRANSLATION OF THE MARK IS "KISS". FOR INTERNET-BASED DATING, SOCIAL INTRODUCTION AND SOCIAL NETWORKING SERVICES; PROVIDING INFORMATION IN THE FIELD OF PERSONAL DEVELOPMENT, NAMELY, SELF-IMPROVEMENT, SELF-FULFILLMENT, AND INTERPERSONAL COMMUNICATION (U.S. CLS. 100 AND 101).

ANDREW LEASER, EXAMINING ATTORNEY

SN 85-291,454. GOTTA HAVE SOLE FOUNDATION, INC., CRANSTON, RI. FILED 4-11-2011.

GOTTA HAVE SOLE

THE MARK CONSISTS OF STANDARD CHARACTERS WITHOUT CLAIM TO ANY PARTICULAR FONT, STYLE, SIZE, OR COLOR.

OWNER OF U.S. REG. NO. 3,860,531. FOR CHARITABLE SERVICES, NAMELY, PROVIDING SHOES TO NEEDY CHILDREN (U.S. CLS. 100 AND 101).

FIRST USE 2-19-2010; IN COMMERCE 2-24-2010.
MICHELLE DUBOIS, EXAMINING ATTORNEY

SN 85-291,733. PINDONE INC, MARINA DEL REY, CA. FILED 4-11-2011.

THE BEST WAY TO GET STUFF DONE

THE MARK CONSISTS OF STANDARD CHARACTERS WITHOUT CLAIM TO ANY PARTICULAR FONT, STYLE, SIZE, OR COLOR.

FOR PERSONAL CONCIERGE SERVICES FOR OTHERS COMPRISING MAKING REQUESTED PERSONAL ARRANGEMENTS AND RESERVATIONS, RUNNING ERRANDS AND PROVIDING CUSTOMER SPECIFIC INFORMATION TO MEET INDIVIDUAL NEEDS, ALL RENDERED IN BUSINESS ESTABLISHMENTS, OFFICE BUILDINGS, HOTELS, RESIDENTIAL COMPLEXES AND HOMES (U.S. CLS. 100 AND 101).

MATTHEW MCDOWELL, EXAMINING ATTORNEY

CLASS 45—(Continued).

SN 85-292,243. ZOOSK, INC., SAN FRANCISCO, CA. FILED 4-11-2011.

ZSMS

THE MARK CONSISTS OF STANDARD CHARACTERS WITHOUT CLAIM TO ANY PARTICULAR FONT, STYLE, SIZE, OR COLOR.

FOR ONLINE DATING SERVICES (U.S. CLS. 100 AND 101).

FIRST USE 8-10-2010; IN COMMERCE 8-10-2010.
MATTHEW EINSTEIN, EXAMINING ATTORNEY

CLASS 45—(Continued).

SN 85-292,538. IAM INC., DIAMOND BAR, CA. FILED 4-12-2011.

IamINC

THE MARK CONSISTS OF STANDARD CHARACTERS WITHOUT CLAIM TO ANY PARTICULAR FONT, STYLE, SIZE, OR COLOR.

FOR ONLINE SOCIAL NETWORKING SERVICES IN THE FIELD OF PERSONAL DEVELOPMENT, NAMELY, SELF-IMPROVEMENT, SELF-FULFILLMENT, CHARITABLE, PHILANTHROPIC, VOLUNTEER, PUBLIC AND COMMUNITY SERVICES, AND HUMANITARIAN ACTIVITIES (U.S. CLS. 100 AND 101).

FIRST USE 3-29-2009; IN COMMERCE 1-25-2011.
THEODORE MCBRIDE, EXAMINING ATTORNEY

SN 85-292,292. MOBILE OFFICE SOFTWARE SOLUTIONS, LLC, VERO BEACH, FL. FILED 4-11-2011.

Trackster

THE MARK CONSISTS OF AN ARROWHEAD AND WORD "TRACKSTER".

FOR ON-LINE SOCIAL NETWORKING SERVICES (U.S. CLS. 100 AND 101).

DAVID C. REIHNER, EXAMINING ATTORNEY

SN 85-292,711. TRAFFIC JAM UNIVERSITY, LLC, SEATTLE, WA. FILED 4-12-2011.

DREAMTOOL

THE MARK CONSISTS OF STANDARD CHARACTERS WITHOUT CLAIM TO ANY PARTICULAR FONT, STYLE, SIZE, OR COLOR.

FOR MEMBERSHIP CLUB SERVICES, NAMELY, PROVIDING ON-LINE INFORMATION TO MEMBERS IN THE FIELDS OF PERSONAL GROWTH AND MOTIVATION, PERSONAL IMAGE DEVELOPMENT, AND PERSONAL DEVELOPMENT, NAMELY, SELF-IMPROVEMENT, SELF-FULFILLMENT, AND INTERPERSONAL COMMUNICATION; ON-LINE SOCIAL NETWORKING SERVICES; SOCIAL NETWORKING SERVICES IN THE FIELD OF PERSONAL GROWTH PROVIDED VIA A WEBSITE (U.S. CLS. 100 AND 101).

FIRST USE 12-22-2010; IN COMMERCE 12-22-2010.
GIANCARLO CASTRO, EXAMINING ATTORNEY

SN 85-292,354. JOHNSON, STEVEN W, PEARLAND, TX. FILED 4-11-2011.

FEARLESS FIVE

THE MARK CONSISTS OF STANDARD CHARACTERS WITHOUT CLAIM TO ANY PARTICULAR FONT, STYLE, SIZE, OR COLOR.

FOR LICENSING OF CARTOON CHARACTERS (U.S. CLS. 100 AND 101).

JULIE WATSON, EXAMINING ATTORNEY

SN 85-293,099. DGENN, LLC, POMPANO BEACH, FL. FILED 4-12-2011.

DGENN

THE MARK CONSISTS OF STANDARD CHARACTERS WITHOUT CLAIM TO ANY PARTICULAR FONT, STYLE, SIZE, OR COLOR.

FOR ON-LINE SOCIAL NETWORKING SERVICES (U.S. CLS. 100 AND 101).

CHRIS WELLS, EXAMINING ATTORNEY

CLASS 45—(Continued).

SN 85-293,123. ROYES, STEPHEN C, RANCHO PALOS VERDES, CA. FILED 4-12-2011.

Make The Strong Stronger

THE MARK CONSISTS OF STANDARD CHARACTERS WITHOUT CLAIM TO ANY PARTICULAR FONT, STYLE, SIZE, OR COLOR.
FOR DIVORCE MEDIATION SERVICES (U.S. CLS. 100 AND 101).
CHRISTINE COOPER, EXAMINING ATTORNEY

SN 85-293,163. TAKEACHANCEWITHME.COM CORP., NAPERVILLE, IL. FILED 4-12-2011.

TakeAChanceWithMe.com

THE MARK CONSISTS OF STANDARD CHARACTERS WITHOUT CLAIM TO ANY PARTICULAR FONT, STYLE, SIZE, OR COLOR.
FOR DATING SERVICES, NAMELY, PROVIDING A WEBSITE FOR SINGLE PEOPLE INTERESTED IN MEETING OTHER SINGLE PEOPLE (U.S. CLS. 100 AND 101).
FIRST USE 1-19-2011; IN COMMERCE 1-19-2011.
JOHN WILKE, EXAMINING ATTORNEY

SN 85-293,210. DGENN, LLC, POMPANO BEACH, FL. FILED 4-12-2011.

NOT YOUR MOTHER'S SOCIAL NETWORK

THE MARK CONSISTS OF STANDARD CHARACTERS WITHOUT CLAIM TO ANY PARTICULAR FONT, STYLE, SIZE, OR COLOR.
FOR ON-LINE SOCIAL NETWORKING SERVICES (U.S. CLS. 100 AND 101).
CHRIS WELLS, EXAMINING ATTORNEY

CLASS 45—(Continued).

SN 85-293,236. BIDE GAIN, SEBASTIAN, MONTEVIDEO, URUGUAY, FILED 4-12-2011.

Stillhere

THE MARK CONSISTS OF STANDARD CHARACTERS WITHOUT CLAIM TO ANY PARTICULAR FONT, STYLE, SIZE, OR COLOR.
FOR ON-LINE SOCIAL NETWORKING SERVICES (U.S. CLS. 100 AND 101).
DAVID COLLIER, EXAMINING ATTORNEY

SN 85-293,249. BIDE GAIN, SEBASTIAN, MONTEVIDEO, URUGUAY, FILED 4-12-2011.



THE COLOR(S) RED, WHITE, AND GRAY IS/ARE CLAIMED AS A FEATURE OF THE MARK.
THE MARK CONSISTS OF THE WORD, "STILL", IN RED LETTERS OUTLINED WITH WHITE; OVERLAPPING A STYLISTIC, RED ARROW, CONTAINING THE WORD, HERE, IN WHITE LETTERS, HAVING GRAY AND WHITE SHADOWING.
FOR ON-LINE SOCIAL NETWORKING SERVICES (U.S. CLS. 100 AND 101).
DAVID COLLIER, EXAMINING ATTORNEY

SN 85-293,308. ALBRIGHT, JR., DAVID F., BALTIMORE, MD. FILED 4-12-2011.

Lead Paint Kills Dreams

THE MARK CONSISTS OF STANDARD CHARACTERS WITHOUT CLAIM TO ANY PARTICULAR FONT, STYLE, SIZE, OR COLOR.
FOR LEGAL SERVICES (U.S. CLS. 100 AND 101).
NELSON SNYDER, EXAMINING ATTORNEY

CLASS 45—(Continued).

SN 85-293,896. NATIONAL SERVICES GROUP, INC., NEW YORK, NY. FILED 4-13-2011.

UBeSEEN

THE MARK CONSISTS OF STANDARD CHARACTERS WITHOUT CLAIM TO ANY PARTICULAR FONT, STYLE, SIZE, OR COLOR.

FOR ON-LINE SOCIAL NETWORKING SERVICES (U.S. CLS. 100 AND 101).
ERIN FALK, EXAMINING ATTORNEY

CLASS 45—(Continued).

SN 85-294,965. NORTHSTAR LITIGATION TECHNOLOGIES, LLC, ROSELAMD, NJ. FILED 4-14-2011.

EXOBASE

THE MARK CONSISTS OF STANDARD CHARACTERS WITHOUT CLAIM TO ANY PARTICULAR FONT, STYLE, SIZE, OR COLOR.

FOR LITIGATION SUPPORT SERVICES (U.S. CLS. 100 AND 101).
ANDREW RHIM, EXAMINING ATTORNEY

SN 85-294,005. LIVING ASSISTANCE SERVICES, INC., HAVERTOWN, PA. FILED 4-13-2011.

WE CARE EVERY DAY IN EVERY WAY

THE MARK CONSISTS OF STANDARD CHARACTERS WITHOUT CLAIM TO ANY PARTICULAR FONT, STYLE, SIZE, OR COLOR.

FOR IN-HOME SUPPORT SERVICES TO SENIOR PERSONS, NAMELY, GERIATRIC CARE MANAGEMENT SERVICES IN THE NATURE OF THE COORDINATION OF NECESSARY SERVICES AND PERSONAL CARE FOR OLDER INDIVIDUALS; PERSONAL CARE ASSISTANCE OF ACTIVITIES OF DAILY LIVING, SUCH AS BATHING, GROOMING AND PERSONAL MOBILITY FOR MENTALLY OR PHYSICALLY CHALLENGED PEOPLE; PROVIDING NON-MEDICAL PERSONAL ASSISTANT SERVICES FOR OTHERS IN THE NATURE OF PLANNING, ORGANIZING, COORDINATING, ARRANGING AND ASSISTING INDIVIDUALS TO PERFORM DAILY TASKS (U.S. CLS. 100 AND 101).

FIRST USE 3-5-2003; IN COMMERCE 3-5-2003.
ALICE BENMAMAN, EXAMINING ATTORNEY

SN 85-295,828. ON TIME MINISTRIES LLC, TACOMA, WA. FILED S.R. 4-14-2011; AM. P.R. 7-20-2011.

Let's Go Get Life!

THE MARK CONSISTS OF STANDARD CHARACTERS WITHOUT CLAIM TO ANY PARTICULAR FONT, STYLE, SIZE, OR COLOR.

FOR EVANGELISTIC AND MINISTERIAL SERVICES (U.S. CLS. 100 AND 101).
FIRST USE 12-10-2010; IN COMMERCE 12-10-2010.
ELISSA GARBER KON, EXAMINING ATTORNEY

SN 85-294,550. THE LAW OFFICES OF BERMAN & BERMAN, P.A., BOCA RATON, FL. FILED 4-13-2011.

COMMITTED TO THE COMMUNITY

THE MARK CONSISTS OF STANDARD CHARACTERS WITHOUT CLAIM TO ANY PARTICULAR FONT, STYLE, SIZE, OR COLOR.

FOR LEGAL SERVICES (U.S. CLS. 100 AND 101).
FIRST USE 11-4-2010; IN COMMERCE 11-4-2010.
HANNO RITTNER, EXAMINING ATTORNEY

SN 85-305,116. FLOYD, SKEREN & KELLY, LLP, CALABASAS, CA. FILED 4-26-2011.

PLEADING GUILTY..... NOT SMART

THE MARK CONSISTS OF STANDARD CHARACTERS WITHOUT CLAIM TO ANY PARTICULAR FONT, STYLE, SIZE, OR COLOR.

FOR LEGAL SERVICES (U.S. CLS. 100 AND 101).
ANDREW LEASER, EXAMINING ATTORNEY

CLASS 45—(Continued).

SN 85-313,509. POST DIVORCE GROUP, LLC, BELLAIRE, TX. FILED 5-5-2011.

CLASS 45—(Continued).

SN 85-329,079. DART INDUSTRIES INC., ORLANDO, FL. FILED 5-24-2011.

MATCH MADE IN HEAVEN

THE MARK CONSISTS OF STANDARD CHARACTERS WITHOUT CLAIM TO ANY PARTICULAR FONT, STYLE, SIZE, OR COLOR.

FOR CONSULTING IN THE FIELD OF PERSONAL RELATIONSHIPS; DATING SERVICES; MARRIAGE PARTNER INTRODUCTION OR DATING SERVICES; MATCHMAKING SERVICES (U.S. CLS. 100 AND 101).
FIRST USE 4-21-2011; IN COMMERCE 4-21-2011.
TEJBIR SINGH, EXAMINING ATTORNEY

CONFIDE + CONQUER

SN 85-313,516. POST DIVORCE GROUP, LLC, BELLAIRE, TX. FILED 5-5-2011.

MIX, MINGLE & MAYBE MEET

THE MARK CONSISTS OF STANDARD CHARACTERS WITHOUT CLAIM TO ANY PARTICULAR FONT, STYLE, SIZE, OR COLOR.

FOR COMPUTER DATING SERVICES; DATING SERVICES, NAMELY, PROVIDING AN ON-LINE COMPUTER DATABASE FEATURING SINGLE PEOPLE INTERESTED IN MEETING OTHER SINGLE PEOPLE; INTERNET BASED SOCIAL NETWORKING, INTRODUCTION, AND DATING SERVICES; PROVIDING A WEB SITE FEATURING INFORMATION AND CONTENT IN THE FIELDS OF PERSONAL RELATIONSHIPS, DATING AND FASHION; WEB SITE SERVICES FEATURING ON-LINE DATING CLUB (U.S. CLS. 100 AND 101).
FIRST USE 4-21-2011; IN COMMERCE 4-21-2011.
TEJBIR SINGH, EXAMINING ATTORNEY

THE MARK CONSISTS OF STANDARD CHARACTERS WITHOUT CLAIM TO ANY PARTICULAR FONT, STYLE, SIZE, OR COLOR.

FOR ON-LINE SOCIAL NETWORKING SERVICES; PROVIDING A SOCIAL NETWORKING WEBSITE AT WHICH A USER CAN GIVE CHARITABLE GIFTS TO OTHERS (U.S. CLS. 100 AND 101).
JULIE GUTTADAURO, EXAMINING ATTORNEY

* * * * *

SECTION 4.—PRIOR UNITED STATES CLASSIFICATION

APPLICATION IN ONE CLASS

CERTIFICATION MARKS

SN 85-125,422. BOARD OF CERTIFIED SAFETY PROFESSIONALS, INC., SAVOY, IL. FILED 9-8-2010.

CLASS A—GOODS

SN 85-279,977. NATIONAL INTELLECTUAL PROPERTY CENTER OF GEORGIA - SAKPATENTI, 0108 TBILISI, REP OF GEORGIA, FILED 3-29-2011.

KARDENAKHI



THE MARK CONSISTS OF STANDARD CHARACTERS WITHOUT CLAIM TO ANY PARTICULAR FONT, STYLE, SIZE, OR COLOR.

THE CERTIFICATION MARK, AS INTENDED TO BE USED BY AUTHORIZED PERSONS, IS INTENDED TO CERTIFY THAT THE GOODS EMANATE FROM A SPECIFIC GEOGRAPHIC REGION, NAMELY, THE ZONE OF KARDENAKHI LOCATED IN THE GURJAANI REGION BETWEEN THE ADMINISTRATIVE BORDERS OF THE VILLAGES OF BAKURTSIKHE AND ANAGI, AND OTHER LOCATIONS SPECIFIED IN THE STANDARDS, IN GEORGIA.

FOR WINE.
MARK SHINER, EXAMINING ATTORNEY

THE MARK CONSISTS OF A DESIGN ELEMENT OF THREE TRIANGLES TOGETHER WITH THE WORD MARK "CSP".

THE CERTIFICATION MARK, AS USED BY AUTHORIZED PERSONS, CERTIFIES THE USER HAS PASSED THE CORE AND SPECIALTY EXAMINATIONS IN THE FIELD OF SAFETY INSPECTION AND EVALUATION.

FOR SAFETY INSPECTION AND SAFETY EVALUATION CONSULTING SERVICES.

FIRST USE 5-1-2010; IN COMMERCE 6-25-2010.
ANGELA DUONG, EXAMINING ATTORNEY

CLASS B—SERVICES

SN 77-931,104. IT SERVICE MANAGEMENT FORUM-USA, PASADENA, CA. FILED 2-9-2010.

FSM

SN 85-165,001. AMERICAN INSTITUTE OF CERTIFIED PUBLIC ACCOUNTANTS, NEW YORK, NY. FILED 10-29-2010.



THE MARK CONSISTS OF STANDARD CHARACTERS WITHOUT CLAIM TO ANY PARTICULAR FONT, STYLE, SIZE, OR COLOR.

THE CERTIFICATION MARK, AS INTENDED TO BE USED BY AUTHORIZED PERSONS, IS INTENDED TO CERTIFY THAT THE PERSON'S SERVICES HAVE DEMONSTRATED A PARTICULAR LEVEL OF COMPETENCY IN THE FIELD OF INFORMATION TECHNOLOGY SERVICE MANAGEMENT SERVICES BY HAVING MET CERTAIN EDUCATIONAL AND EXPERIENTIAL STANDARDS FOR INFORMATION TECHNOLOGY SERVICE MANAGEMENT SERVICES SET BY THE CERTIFIER.

FOR INFORMATION TECHNOLOGY SERVICE MANAGEMENT SERVICES.
MARC LEIPZIG, EXAMINING ATTORNEY

OWNER OF U.S. REG. NOS. 2,563,922 AND 3,064,029.
NO CLAIM IS MADE TO THE EXCLUSIVE RIGHT TO USE "CPA" AND "ACCREDITED IN BUSINESS VALUATION", APART FROM THE MARK AS SHOWN.

THE MARK CONSISTS OF THE LETTERS "CPA" ABOVE A LARGELY HORIZONTAL LINE WHICH, AT THE ENDS OF THE LINE, CURVES TOWARDS OR AROUND THE LETTERS "CPA", ALONG WITH THE LETTERS "ABV" ABOVE THE WORDS "ACCREDITED IN BUSINESS VALUATION".

THE CERTIFICATION MARK, AS USED BY AUTHORIZED PERSONS, CERTIFIES THAT SUCH PERSONS HAVE SATISFIED THE RIGID STANDARDS OF TRAINING, CONTINUING EDUCATION AND EXPERIENCE IN THE FIELD OF ENTERPRISE APPRAISING, AS ESTABLISHED BY THE CERTIFIER.

SEC. 2(F) "ABV".
FOR BUSINESS ENTERPRISE APPRAISING SERVICES.
FIRST USE 5-10-2010; IN COMMERCE 5-10-2010.
BILL DAWE, EXAMINING ATTORNEY

SN 85-285,315. AMERICAN OSTEOPATHIC ASSOCIATION,
CHICAGO, IL. FILED 4-4-2011.

AMERICAN OSTEOPATHIC BOARD OF OBSTETRICS AND GYNECOLOGY

THE MARK CONSISTS OF STANDARD CHARACTERS WITHOUT CLAIM TO ANY PARTICULAR FONT, STYLE, SIZE, OR COLOR.

NO CLAIM IS MADE TO THE EXCLUSIVE RIGHT TO USE "BOARD OF OBSTETRICS AND GYNECOLOGY", APART FROM THE MARK AS SHOWN.

THE CERTIFICATION MARK, AS USED BY PERSONS AUTHORIZED BY THE CERTIFIER, CERTIFIES THAT THE SERVICE PROVIDER HAS MET CERTAIN MINIMUM FORMAL EDUCATION STANDARDS, MAINTAINS CURRENT CERTIFICATION OR LICENSURE IN THEIR HEALTHCARE FIELD, AND HAS MET EXPERIENCE STANDARDS IN THE FIELD OF OBSTETRICS AND GYNECOLOGY, AND THAT THE WORK IN RENDERING THE SERVICES WAS PERFORMED BY PERSONS WHO HAVE MET THE STANDARDS AND CRITERIA ESTABLISHED BY THE CERTIFIER.

SEC. 2(F).

FOR HEALTHCARE SERVICES.

FIRST USE 0-0-1942; IN COMMERCE 0-0-1942.

ALYSSA STEEL, EXAMINING ATTORNEY

SN 85-285,461. AMERICAN OSTEOPATHIC ASSOCIATION,
CHICAGO, IL. FILED 4-4-2011.

AMERICAN OSTEOPATHIC BOARD OF SURGERY

THE MARK CONSISTS OF STANDARD CHARACTERS WITHOUT CLAIM TO ANY PARTICULAR FONT, STYLE, SIZE, OR COLOR.

NO CLAIM IS MADE TO THE EXCLUSIVE RIGHT TO USE "BOARD OF SURGERY", APART FROM THE MARK AS SHOWN.

THE CERTIFICATION MARK, AS USED BY PERSONS AUTHORIZED BY THE CERTIFIER, CERTIFIES THAT THE SERVICE PROVIDER HAS MET CERTAIN MINIMUM FORMAL EDUCATION STANDARDS, MAINTAINS CURRENT CERTIFICATION OR LICENSURE IN THEIR HEALTHCARE FIELD, AND HAS MET EXPERIENCE STANDARDS IN THE FIELD OF SURGERY, AND THAT THE WORK IN RENDERING THE SERVICES WAS PERFORMED BY PERSONS WHO HAVE MET THE STANDARDS AND CRITERIA ESTABLISHED BY THE CERTIFIER.

SEC. 2(F).

FOR HEALTHCARE SERVICES.

FIRST USE 0-0-1940; IN COMMERCE 0-0-1940.

ALYSSA STEEL, EXAMINING ATTORNEY

SN 85-285,527. AMERICAN OSTEOPATHIC ASSOCIATION,
CHICAGO, IL. FILED 4-4-2011.

AMERICAN OSTEOPATHIC BOARD OF FAMILY PHYSICIANS

THE MARK CONSISTS OF STANDARD CHARACTERS WITHOUT CLAIM TO ANY PARTICULAR FONT, STYLE, SIZE, OR COLOR.

NO CLAIM IS MADE TO THE EXCLUSIVE RIGHT TO USE "BOARD OF FAMILY PHYSICIANS", APART FROM THE MARK AS SHOWN.

THE CERTIFICATION MARK, AS USED BY PERSONS AUTHORIZED BY THE CERTIFIER, CERTIFIES THAT THE SERVICE PROVIDER HAS MET CERTAIN MINIMUM FORMAL EDUCATION STANDARDS, MAINTAINS CURRENT CERTIFICATION OR LICENSURE IN THEIR HEALTHCARE FIELD, AND HAS MET EXPERIENCE STANDARDS IN THE FIELD OF FAMILY PHYSICIANS, AND THAT THE WORK IN RENDERING THE SERVICES WAS PERFORMED BY PERSONS WHO HAVE MET THE STANDARDS AND CRITERIA ESTABLISHED BY THE CERTIFIER.

SEC. 2(F).

FOR HEALTHCARE SERVICES.

FIRST USE 0-0-1972; IN COMMERCE 0-0-1972.

ALYSSA STEEL, EXAMINING ATTORNEY

SN 85-285,554. AMERICAN OSTEOPATHIC ASSOCIATION,
CHICAGO, IL. FILED 4-4-2011.

AMERICAN OSTEOPATHIC BOARD OF EMERGENCY MEDICINE

THE MARK CONSISTS OF STANDARD CHARACTERS WITHOUT CLAIM TO ANY PARTICULAR FONT, STYLE, SIZE, OR COLOR.

NO CLAIM IS MADE TO THE EXCLUSIVE RIGHT TO USE "BOARD OF EMERGENCY MEDICINE", APART FROM THE MARK AS SHOWN.

THE CERTIFICATION MARK, AS USED BY PERSONS AUTHORIZED BY THE CERTIFIER, CERTIFIES THAT THE SERVICE PROVIDER HAS MET CERTAIN MINIMUM FORMAL EDUCATION STANDARDS, MAINTAINS CURRENT CERTIFICATION OR LICENSURE IN THEIR HEALTHCARE FIELD, AND HAS MET EXPERIENCE STANDARDS IN THE FIELD OF EMERGENCY MEDICINE, AND THAT THE WORK IN RENDERING THE SERVICES WAS PERFORMED BY PERSONS WHO HAVE MET THE STANDARDS AND CRITERIA ESTABLISHED BY THE CERTIFIER.

SEC. 2(F).

FOR HEALTHCARE SERVICES.

FIRST USE 0-0-1980; IN COMMERCE 0-0-1980.

ALYSSA STEEL, EXAMINING ATTORNEY

SN 85-285,574. AMERICAN OSTEOPATHIC ASSOCIATION,
CHICAGO, IL. FILED 4-4-2011.

AMERICAN OSTEOPATHIC BOARD OF INTERNAL MEDICINE

THE MARK CONSISTS OF STANDARD CHARACTERS WITHOUT CLAIM TO ANY PARTICULAR FONT, STYLE, SIZE, OR COLOR.

NO CLAIM IS MADE TO THE EXCLUSIVE RIGHT TO USE "BOARD OF INTERNAL MEDICINE", APART FROM THE MARK AS SHOWN.

THE CERTIFICATION MARK, AS USED BY PERSONS

AUTHORIZED BY THE CERTIFIER, CERTIFIES THAT THE SERVICE PROVIDER HAS MET CERTAIN MINIMUM FORMAL EDUCATION STANDARDS, MAINTAINS CURRENT CERTIFICATION OR LICENSURE IN THEIR HEALTHCARE FIELD, AND HAS MET EXPERIENCE STANDARDS IN THE FIELD OF INTERNAL MEDICINE, AND THAT THE WORK IN RENDERING THE SERVICES WAS PERFORMED BY PERSONS WHO HAVE MET THE STANDARDS AND CRITERIA ESTABLISHED BY THE CERTIFIER.

SEC. 2(F).
FOR HEALTHCARE SERVICES.
FIRST USE 0-0-1942; IN COMMERCE 0-0-1942.
ALYSSA STEEL, EXAMINING ATTORNEY

NO CLAIM IS MADE TO THE EXCLUSIVE RIGHT TO USE "BOARD OF NEUROMUSCULOSKELETAL MEDICINE", APART FROM THE MARK AS SHOWN.

THE CERTIFICATION MARK, AS USED BY PERSONS AUTHORIZED BY THE CERTIFIER, CERTIFIES THAT THE SERVICE PROVIDER HAS MET CERTAIN MINIMUM FORMAL EDUCATION STANDARDS, MAINTAINS CURRENT CERTIFICATION OR LICENSURE IN THEIR HEALTHCARE FIELD, AND HAS MET EXPERIENCE STANDARDS IN THE FIELD OF NEUROMUSCULOSKELETAL MEDICINE, AND THAT THE WORK IN RENDERING THE SERVICES WAS PERFORMED BY PERSONS WHO HAVE MET THE STANDARDS AND CRITERIA ESTABLISHED BY THE CERTIFIER.

SEC. 2(F).
FOR HEALTHCARE SERVICES.
FIRST USE 0-0-1977; IN COMMERCE 0-0-1977.
ALYSSA STEEL, EXAMINING ATTORNEY

SN 85-286,240. AMERICAN OSTEOPATHIC ASSOCIATION,
CHICAGO, IL. FILED 4-5-2011.

AMERICAN OSTEOPATHIC
BOARD OF
NEUROMUSCULOSKELETAL
MEDICINE

THE MARK CONSISTS OF STANDARD CHARACTERS WITHOUT CLAIM TO ANY PARTICULAR FONT, STYLE, SIZE, OR COLOR.

* * * * *

TRADEMARK REGISTRATIONS ISSUED

PRINCIPAL REGISTER

SECTION 1.— INTERNATIONAL CLASSIFICATION

The short titles associated below with the international class numbers are terms designed merely for quick identification and are not an official part of the international classification. The full names of international classes are given in section 6.1 of the trademark rules of practice.

The designation "U.S. Cl." appearing in this section refers to the U.S. class in effect prior to Sep. 1, 1973 rather than the international class which applies to applications filed on or after that date. For adoption of international classification see notice in the OFFICIAL GAZETTE of Jun. 26, 1973 (911 O.G. TM 210).

CLASS 1—CHEMICALS

- 4,014,292. **TAKING CARE OF CLEAN POWER AND AIR (STANDARD CHARACTER)**. SÜD-CHEMIE AG, MULTIPLE CLASS, (INT. CLS. 1, 37 AND 42), (U.S. CLS. 1, 5, 6, 10, 26, 46, 100, 101, 103 AND 106). SN 77-669,195. PUB. 7-6-2010. FILED 2-12-2009.
- 4,014,320. **USHSTAT (STANDARD CHARACTER)**. OXFORD BIOMEDICA PLC, MULTIPLE CLASS, (INT. CLS. 1, 5, 10 AND 42), (U.S. CLS. 1, 5, 6, 10, 18, 26, 39, 44, 46, 51, 52, 100 AND 101). SN 77-767,342. PUB. 1-18-2011. FILED 6-24-2009.
- 4,014,358. **LDA (STANDARD CHARACTER)**. LORAMA INC., (U.S. CLS. 1, 5, 6, 10, 26 AND 46). SN 77-882,204. PUB. 6-7-2011. FILED 11-30-2009.
- 4,014,359. **LPC (STANDARD CHARACTER)**. LORAMA INC., (U.S. CLS. 1, 5, 6, 10, 26 AND 46). SN 77-882,233. PUB. 6-7-2011. FILED 11-30-2009.
- 4,014,402. **ALTIMA ADHESIVES (STANDARD CHARACTER)**. INTEGRA ADHESIVES INC., (U.S. CLS. 1, 5, 6, 10, 26 AND 46). SN 77-938,850. PUB. 6-7-2011. FILED 2-18-2010.
- 4,014,436. **GREEN THUMB (STANDARD CHARACTER)**. TRUE VALUE COMPANY, MULTIPLE CLASS, (INT. CLS. 1 AND 2), (U.S. CLS. 1, 5, 6, 10, 11, 16, 26 AND 46). SN 78-595,993. PUB. 6-7-2011. FILED 3-28-2005.
- 4,014,460. **CLINTEST (STANDARD CHARACTER)**. RECIPE CHEMICALS + INSTRUMENTS GMBH, MULTIPLE CLASS, (INT. CLS. 1, 5 AND 9), (U.S. CLS. 1, 5, 6, 10, 18, 21, 23, 26, 36, 38, 44, 46, 51 AND 52). SN 79-074,193. PUB. 6-7-2011. FILED 9-2-2009.
- 4,014,469. **TENSA (STANDARD CHARACTER)**. OÜ TERVSLIKU PIIMA BIOTEHNOLOOGIATE; ARENDUSKESKUS, MULTIPLE CLASS, (INT. CLS. 1, 5, 29, 30, 31 AND 32), (U.S. CLS. 1, 5, 6, 10, 18, 26, 44, 45, 46, 48, 51 AND 52). SN 79-078,358. PUB. 6-7-2011. FILED 12-9-2009.
- 4,014,506. **SIEMENS CLIMATE SOLUTIONS (STANDARD CHARACTER)**. SIEMENS AKTIENGESELLSCHAFT, MULTIPLE CLASS, (INT. CLS. 1, 7, 9, 10, 11, 12, 16, 35, 36, 38, 41 AND 42), (U.S. CLS. 1, 2, 5, 6, 10, 13, 19, 21, 22, 23, 26, 29, 31, 34, 35, 36, 37, 38, 39, 44, 46, 50, 100, 101, 102, 104 AND 107). SN 79-084,359. PUB. 6-7-2011. FILED 12-30-2009.
- 4,014,512. **SILICO (STANDARD CHARACTER)**. ASK CHEMICALS GMBH, (U.S. CLS. 1, 5, 6, 10, 26 AND 46). SN 79-084,748. PUB. 6-7-2011. FILED 6-17-2010.
- 4,014,525. **HINSBET (STANDARD CHARACTER)**. ADOCIA, MULTIPLE CLASS, (INT. CLS. 1 AND 5), (U.S. CLS. 1, 5, 6, 10, 18, 26, 44, 46, 51 AND 52). SN 79-085,494. PUB. 6-7-2011. FILED 7-9-2010.
- 4,014,555. **KOHJIN (STANDARD CHARACTER)**. KOHJIN CO., LTD., MULTIPLE CLASS, (INT. CLS. 1, 4, 16 AND 17), (U.S. CLS. 1, 2, 5, 6, 10, 12, 13, 15, 22, 23, 26, 29, 35, 37, 38, 46 AND 50). SN 79-087,054. PUB. 6-7-2011. FILED 6-29-2010.
- 4,014,576. **SOLITEC (STANDARD CHARACTER)**. ASK CHEMICALS GMBH, (U.S. CLS. 1, 5, 6, 10, 26 AND 46). SN 79-088,270. PUB. 6-7-2011. FILED 6-17-2010.
- 4,014,601. **BEEBOND (STANDARD CHARACTER)**. BEELE ENGINEERING B.V., (U.S. CLS. 1, 5, 6, 10, 26 AND 46). SN 79-090,013. PUB. 6-7-2011. FILED 10-19-2010.
- 4,014,604. **PUREMIN (STANDARD CHARACTER)**. CHEMISCHE FABRIK BUDENHEIM KG, MULTIPLE CLASS, (INT. CLS. 1 AND 5), (U.S. CLS. 1, 5, 6, 10, 18, 26, 44, 46, 51 AND 52). SN 79-090,333. PUB. 3-22-2011. FILED 11-3-2010.
- 4,014,610. **SENSOIL (STANDARD CHARACTER)**. CENTRE D'ETUDES DE PHYSIOLOGIE D'HYGIENE ET DE COSMETOLOGIE (C.E.P.), (U.S. CLS. 1, 5, 6, 10, 26 AND 46). SN 79-090,615. PUB. 6-7-2011. FILED 9-22-2010.
- 4,014,635. **CHEMO AND DESIGN**. CHEMO IBERICA, S.A., MULTIPLE CLASS, (INT. CLS. 1, 5 AND 42), (U.S. CLS. 1, 5, 6, 10, 18, 26, 44, 46, 51, 52, 100 AND 101). SN 79-092,685. PUB. 6-7-2011. FILED 12-16-2010.
- 4,014,641. **SPEEDTEC (STANDARD CHARACTER)**. LIQUI - MOLY GESELLSCHAFT MIT BESCHRÄNKTER HAF - TUNG, MULTIPLE CLASS, (INT. CLS. 1 AND 4), (U.S. CLS. 1, 5, 6, 10, 15, 26 AND 46). SN 79-093,142. PUB. 6-7-2011. FILED 12-7-2010.
- 4,014,776. **ILI AND DESIGN**. INTERNATIONAL LUBRICANTS, INC., MULTIPLE CLASS, (INT. CLS. 1 AND 4), (U.S. CLS. 1, 5, 6, 10, 15, 26 AND 46). SN 85-065,959. PUB. 6-7-2011. FILED 6-17-2010.
- 4,014,868. **ECO-FRIENDLY AND DESIGN**. PERMEATOR DISTRIBUTORS LLC, MULTIPLE CLASS, (INT. CLS. 1 AND 3), (U.S. CLS. 1, 4, 5, 6, 10, 26, 46, 50, 51 AND 52). SN 85-085,627. PUB. 6-7-2011. FILED 7-15-2010.
- 4,014,931. **FUELTEX (STANDARD CHARACTER)**. ELASTOGEN LLC, (U.S. CLS. 1, 5, 6, 10, 26 AND 46). SN 85-096,427. PUB. 6-7-2011. FILED 7-29-2010.
- 4,015,001. **LIPOMOD (STANDARD CHARACTER)**. BIOCATALYSTS LIMITED, (U.S. CLS. 1, 5, 6, 10, 26 AND 46). SN 85-120,789. PUB. 6-7-2011. FILED 9-1-2010.
- 4,015,010. **DELO-DUOPOX (STANDARD CHARACTER)**. DELO INDUSTRIAL ADHESIVES LLC, (U.S. CLS. 1, 5, 6, 10, 26 AND 46). SN 85-121,564. PUB. 6-7-2011. FILED 9-2-2010.
- 4,015,031. **POWER FLUIDS ENGINEERED PERFORMANCE AND DESIGN**. AUSBURN, MARTIN, (U.S. CLS. 1, 5, 6, 10, 26 AND 46). SN 85-126,486. PUB. 6-7-2011. FILED 9-9-2010.
- 4,015,204. **FRONTIER SCIENTIFIC (STANDARD CHARACTER)**. FRONTIER SCIENTIFIC, INC., MULTIPLE CLASS, (INT. CLS. 1, 40 AND 42), (U.S. CLS. 1, 5, 6, 10, 26, 46, 100, 101, 103 AND 106). SN 85-178,305. PUB. 6-7-2011. FILED 11-16-2010.
- 4,015,460. **AMPLIPHOX (STANDARD CHARACTER)**. INDEV, INC., MULTIPLE CLASS, (INT. CLS. 1 AND 9), (U.S. CLS. 1, 5, 6, 10, 21, 23, 26, 36, 38 AND 46). SN 85-217,515. PUB. 6-7-2011. FILED 1-13-2011.
- 4,015,526. **SORBADISC (STANDARD CHARACTER)**. MULTISORB TECHNOLOGIES, INC., (U.S. CLS. 1, 5, 6, 10, 26 AND 46). SN 85-219,992. PUB. 6-7-2011. FILED 1-18-2011.
- 4,015,687. **REPAR AND DESIGN**. REPAR CORPORATION, MULTIPLE CLASS, (INT. CLS. 1 AND 5), (U.S. CLS. 1, 5, 6, 10, 18, 26, 44, 46, 51 AND 52). SN 85-226,182. PUB. 6-7-2011. FILED 1-26-2011.
- 4,015,822. **SOILNOC (STANDARD CHARACTER)**. AGVERRA, LLC, (U.S. CLS. 1, 5, 6, 10, 26 AND 46). SN 85-229,592. PUB. 6-7-2011. FILED 1-30-2011.
- 4,015,828. **PHYTOSOURCE (STANDARD CHARACTER)**. PHYTOSOURCE, INC., MULTIPLE CLASS, (INT. CLS. 1 AND 5), (U.S. CLS. 1, 5, 6, 10, 18, 26, 44, 46, 51 AND 52). SN 85-229,668. PUB. 6-7-2011. FILED 1-30-2011.
- 4,015,873. **ZAP-HYBRIDOMA (STANDARD CHARACTER)**

- VENTRIA BIOSCIENCE, (U.S. CLS. 1, 5, 6, 10, 26 AND 46). SN 85-230,470. PUB. 6-7-2011. FILED 1-31-2011.
- 4,015,909. **AQUAMEDIX (STANDARD CHARACTER)**. ENVIRO-TECH OF AMERICA, INC., (U.S. CLS. 1, 5, 6, 10, 26 AND 46). SN 85-230,983. PUB. 6-7-2011. FILED 2-1-2011.
- 4,016,035. **PHOSCONTROL (STANDARD CHARACTER)**. LAKE RESTORATION INC., (U.S. CLS. 1, 5, 6, 10, 26 AND 46). SN 85-233,292. PUB. 6-7-2011. FILED 2-3-2011.
- 4,016,088. **AGRASYST (STANDARD CHARACTER)**. AGRASYST, (U.S. CLS. 1, 5, 6, 10, 26 AND 46). SN 85-246,275. PUB. 6-7-2011. FILED 2-18-2011.

CLASS 2—PAINTS

- 4,014,234. **RAINKOTE (STANDARD CHARACTER)**. HARRY MILLER CORP., (U.S. CLS. 6, 11 AND 16). SN 76-706,222. PUB. 6-7-2011. FILED 2-1-2011.
- 4,014,280. **DURABULL (STANDARD CHARACTER)**. 101058955 SASKATCHEWAN LTD., MULTIPLE CLASS, (INT. CLS. 2, 17 AND 35), (U.S. CLS. 1, 5, 6, 11, 12, 13, 16, 35, 50, 100, 101 AND 102). SN 77-609,167. PUB. 4-19-2011. FILED 11-6-2008.
- 4,014,281. **DURABULL POLY PRODUCTS AND DESIGN**. 101058955 SASKATCHEWAN LTD., MULTIPLE CLASS, (INT. CLS. 2, 17 AND 35), (U.S. CLS. 1, 5, 6, 11, 12, 13, 16, 35, 50, 100, 101 AND 102). SN 77-609,189. PUB. 4-19-2011. FILED 11-6-2008.
- 4,014,436 (*See Class 1 for this trademark*).
- 4,014,596. **AWLSPAR (STANDARD CHARACTER)**. AKZO NOBEL COATINGS INTERNATIONAL B.V., (U.S. CLS. 6, 11 AND 16). SN 79-089,761. PUB. 6-7-2011. FILED 9-29-2010.
- 4,014,623. **AWLCARE (STANDARD CHARACTER)**. AKZO NOBEL COATINGS INTERNATIONAL B.V., (U.S. CLS. 6, 11 AND 16). SN 79-091,364. PUB. 6-7-2011. FILED 10-14-2010.
- 4,014,676. **INOPAZ (STANDARD CHARACTER)**. PAZKAR LTD., MULTIPLE CLASS, (INT. CLS. 2 AND 17), (U.S. CLS. 1, 5, 6, 11, 12, 13, 16, 35 AND 50). SN 85-013,380. PUB. 6-7-2011. FILED 4-14-2010.
- 4,014,759. **CNCS (STANDARD CHARACTER)**. NCS COLOUR AKTIEBOLAG, MULTIPLE CLASS, (INT. CLS. 2, 9, 16, 24 AND 42), (U.S. CLS. 2, 5, 6, 11, 16, 21, 22, 23, 26, 29, 36, 37, 38, 42, 50, 100 AND 101). SN 85-061,818. PUB. 6-7-2011. FILED 6-14-2010.
- 4,014,915. **ENDURA AND DESIGN**. A.M.E. INTERNATIONAL, INC., MULTIPLE CLASS, (INT. CLS. 2 AND 3), (U.S. CLS. 1, 4, 6, 11, 16, 50, 51 AND 52). SN 85-094,663. PUB. 6-7-2011. FILED 7-28-2010.
- 4,015,257. **PAINTSCRATCH (STANDARD CHARACTER)**. BIO PAC, INC., (U.S. CLS. 6, 11 AND 16). SN 85-193,314. PUB. 6-7-2011. FILED 12-8-2010.
- 4,015,300. **INKSENSE RELIABLE, RESOURCEFUL, ECONOMIC, DELIVERED (STANDARD CHARACTER)**. PATRICK JOSEPH QUIRKE, DBA INKSENSE, (U.S. CLS. 6, 11 AND 16). SN 85-200,234. PUB. 6-7-2011. FILED 12-17-2010.
- 4,015,350. **THERMAL-CHEM (STANDARD CHARACTER)**. ARMITAGE INDUSTRIES, INC., DBA THERMAL-CHEM CORP., (U.S. CLS. 6, 11 AND 16). SN 85-207,585. PUB. 6-7-2011. FILED 12-29-2010.
- 4,015,911. **E-212-A (STANDARD CHARACTER)**. WISE CHEM LLC, (U.S. CLS. 6, 11 AND 16). SN 85-231,005. PUB. 6-7-2011. FILED 2-1-2011.
- 4,015,914. **E-212-B (STANDARD CHARACTER)**. WISE CHEM LLC, (U.S. CLS. 6, 11 AND 16). SN 85-231,039. PUB. 6-7-2011. FILED 2-1-2011.
- 4,015,918. **E-115 (STANDARD CHARACTER)**. WISE CHEM LLC, (U.S. CLS. 6, 11 AND 16). SN 85-231,055. PUB. 6-7-2011. FILED 2-1-2011.
- FILED 12-24-2002.
- 4,014,200. **GLO. CALEEL + HAYDEN, L.L.C., MULTIPLE CLASS**, (INT. CLS. 3, 18, 35 AND 44), (U.S. CLS. 1, 2, 3, 4, 6, 22, 41, 50, 51, 52, 100, 101 AND 102). SN 76-480,640. PUB. 3-1-2011. FILED 1-7-2003.
- 4,014,210. **3SHADESLIGHTER (STANDARD CHARACTER)**. GREEK ISLAND LABS, LLC, (U.S. CLS. 1, 4, 6, 50, 51 AND 52). SN 76-703,134. PUB. 6-7-2011. FILED 5-27-2010.
- 4,014,299. **ABSOLUTELY FABULOUS (STANDARD CHARACTER)**. LAYCOCK, SUSAN S., DBA ABSOLUTELY FABULOUS SOAP COMPANY, (U.S. CLS. 1, 4, 6, 50, 51 AND 52). SN 77-700,349. PUB. 6-7-2011. FILED 3-26-2009.
- 4,014,325. **TOE CHI (STANDARD CHARACTER)**. MARGIE YOUNG LEMONS, DBA HILL COUNTRY HAIKU, (U.S. CLS. 1, 4, 6, 50, 51 AND 52). SN 77-779,172. PUB. 11-17-2009. FILED 7-12-2009.
- 4,014,327. **NYR ORGANIC (STANDARD CHARACTER)**. NEAL'S YARD (NATURAL REMEDIES) LIMITED, MULTIPLE CLASS, (INT. CLS. 3, 5, 9, 16, 29, 30, 31, 35, 41, 43 AND 44), (U.S. CLS. 1, 2, 4, 5, 6, 18, 21, 22, 23, 26, 29, 36, 37, 38, 44, 46, 50, 51, 52, 100, 101, 102 AND 107). SN 77-796,453. PUB. 6-7-2011. FILED 8-4-2009.
- 4,014,346. **UNTITLED (STANDARD CHARACTER)**. L'OREAL, (U.S. CLS. 1, 4, 6, 50, 51 AND 52). SN 77-850,622. PUB. 6-7-2011. FILED 10-16-2009.
- 4,014,350. **GEBAUER CONSUMER HEALTHCARE (STANDARD CHARACTER)**. GEBAUER COMPANY, MULTIPLE CLASS, (INT. CLS. 3 AND 5), (U.S. CLS. 1, 4, 6, 18, 44, 46, 50, 51 AND 52). SN 77-858,960. PUB. 6-7-2011. FILED 10-28-2009.
- 4,014,419. **WHOOSH! (STANDARD CHARACTER)**. GARFINKEL, KENNETH A., DBA WHOOSH!, AND ENVIROSTREME SOLUTIONS, AND KIRSCHNER, JULIUS, DBA WHOOSH!, AND ENVIROSTREME SOLUTIONS, (U.S. CLS. 1, 4, 6, 50, 51 AND 52). SN 77-955,509. PUB. 6-7-2011. FILED 3-10-2010.
- 4,014,429. **ELEMENTSIX (STANDARD CHARACTER)**. ELEMENT SIX, MULTIPLE CLASS, (INT. CLS. 3, 7, 9 AND 10), (U.S. CLS. 1, 4, 6, 13, 19, 21, 23, 26, 31, 34, 35, 36, 38, 39, 44, 50, 51 AND 52). SN 77-982,304. PUB. 6-9-2009. FILED 11-5-2007.
- 4,014,432. **E6 (STYLIZED)**. ELEMENT SIX, MULTIPLE CLASS, (INT. CLS. 3, 7, 9 AND 10), (U.S. CLS. 1, 4, 6, 13, 19, 21, 23, 26, 31, 34, 35, 36, 38, 39, 44, 50, 51 AND 52). SN 77-982,342. PUB. 6-30-2009. FILED 11-5-2007.
- 4,014,445. **MAFIWEAR (STANDARD CHARACTER)**. KOMPA S.R.L., MULTIPLE CLASS, (INT. CLS. 3, 9, 14, 16, 18 AND 25), (U.S. CLS. 1, 2, 3, 4, 5, 6, 21, 22, 23, 26, 27, 28, 29, 36, 37, 38, 39, 41, 50, 51 AND 52). SN 79-019,734. PUB. 6-7-2011. FILED 10-3-2005.
- 4,014,464. **BRUNELLO CUCINELLI (STANDARD CHARACTER)**. BRUNELLO CUCINELLI S.P.A., MULTIPLE CLASS, (INT. CLS. 3, 9, 18, 24 AND 35), (U.S. CLS. 1, 2, 3, 4, 6, 21, 22, 23, 26, 36, 38, 41, 42, 50, 51, 52, 100, 101 AND 102). SN 79-076,627. PUB. 6-7-2011. FILED 10-21-2009.
- 4,014,476. **INTERIORS AND DESIGN**. OBCHTCHESTVO S OGRANITCHENNOI; OTVETSTVENNOSTYOU "NAMES", MULTIPLE CLASS, (INT. CLS. 3, 20, 35 AND 42), (U.S. CLS. 1, 2, 4, 6, 13, 22, 25, 32, 50, 51, 52, 100, 101 AND 102). SN 79-079,019. PUB. 6-7-2011. FILED 12-30-2009.
- 4,014,478. **NAMES (STANDARD CHARACTER)**. OBCHTCHESTVO S OGRANITCHENNOI; OTVETSTVENNOSTYOU "NAMES", MULTIPLE CLASS, (INT. CLS. 3, 20, 35 AND 42), (U.S. CLS. 1, 2, 4, 6, 13, 22, 25, 32, 50, 51, 52, 100, 101 AND 102). SN 79-079,058. PUB. 6-7-2011. FILED 12-30-2009.
- 4,014,497. **GARETH PUGH (STANDARD CHARACTER)**. HARD AND SHINY S.R.L., MULTIPLE CLASS, (INT. CLS. 3, 9, 14, 18 AND 25), (U.S. CLS. 1, 2, 3, 4, 6, 21, 22, 23, 26, 27, 28, 36, 38, 39, 41, 50, 51 AND 52). SN 79-083,091. PUB. 6-7-2011. FILED 4-12-2010.
- 4,014,524. **KANELLIA (STANDARD CHARACTER)**. LABORATOIRES D'ETHNO-COSMETIQUE ACTINEA, (U.S. CLS. 1, 4, 6, 50, 51 AND 52). SN 79-085,490. PUB. 6-7-2011. FILED 6-11-2010.
- 4,014,534. **CASINO DE PARIS (STANDARD CHARACTER)**. CASINO DE PARIS, (U.S. CLS. 1, 4, 6, 50, 51 AND 52). SN 79-085,781. PUB. 6-7-2011. FILED 4-20-2010.
- 4,014,562. **MON HUILE NATURE (STYLIZED)**. L'OCCITANE, (U.S. CLS. 1, 4, 6, 50, 51 AND 52). SN 79-087,315. PUB. 6-7-2011. FILED 5-11-2010.

CLASS 3—COSMETICS AND CLEANING PREPARATIONS

- 4,014,199. **GLO AND DESIGN**. CALEEL + HAYDEN, L.L.C., MULTIPLE CLASS, (INT. CLS. 3 AND 18), (U.S. CLS. 1, 2, 3, 4, 6, 22, 41, 50, 51 AND 52). SN 76-477,856. PUB. 3-1-2011.

- 4,014,595. **K-FEE SYSTEM AND DESIGN**. KRÜGER GMBH & CO. KG, (U.S. CLS. 1, 4, 6, 50, 51 AND 52). SN 79-089,718. PUB. 6-7-2011. FILED 10-1-2010.
- 4,014,606. **THT (STANDARD CHARACTER)**. REGEN LAB SA, MULTIPLE CLASS, (INT. CLS. 3, 5 AND 10), (U.S. CLS. 1, 4, 6, 18, 26, 39, 44, 46, 50, 51 AND 52). SN 79-090,467. PUB. 6-7-2011. FILED 10-7-2010.
- 4,014,612. **A-CPKIT (STANDARD CHARACTER)**. REGEN LAB SA, MULTIPLE CLASS, (INT. CLS. 3, 5 AND 10), (U.S. CLS. 1, 4, 6, 18, 26, 39, 44, 46, 50, 51 AND 52). SN 79-090,691. PUB. 6-7-2011. FILED 10-7-2010.
- 4,014,613. **A-PRP (STANDARD CHARACTER)**. REGEN LAB SA, MULTIPLE CLASS, (INT. CLS. 3, 5 AND 10), (U.S. CLS. 1, 4, 6, 18, 26, 39, 44, 46, 50, 51 AND 52). SN 79-090,692. PUB. 6-7-2011. FILED 10-7-2010.
- 4,014,622. **AWLWASH (STANDARD CHARACTER)**. AKZO NOBEL COATINGS INTERNATIONAL B.V., (U.S. CLS. 1, 4, 6, 50, 51 AND 52). SN 79-091,363. PUB. 6-7-2011. FILED 10-14-2010.
- 4,014,648. **KLINGSPOR (STANDARD CHARACTER)**. KLINGSPOR AG, MULTIPLE CLASS, (INT. CLS. 3, 7 AND 8), (U.S. CLS. 1, 4, 6, 13, 19, 21, 23, 28, 31, 34, 35, 44, 50, 51 AND 52). SN 79-094,488. PUB. 6-7-2011. FILED 7-19-2010.
- 4,014,701. **LISCIO (STANDARD CHARACTER)**. MILBON CO., LTD., (U.S. CLS. 1, 4, 6, 50, 51 AND 52). SN 85-037,771. PUB. 6-7-2011. FILED 5-13-2010.
- 4,014,702. **K (STYLIZED)**. KARMISSIE, LLC, MULTIPLE CLASS, (INT. CLS. 3, 5 AND 8), (U.S. CLS. 1, 4, 6, 18, 23, 28, 44, 46, 50, 51 AND 52). SN 85-038,370. PUB. 6-7-2011. FILED 5-13-2010.
- 4,014,736. **ENVIROPROTECT (STANDARD CHARACTER)**. ALLISON CLINICAL ENTERPRISES, (U.S. CLS. 1, 4, 6, 50, 51 AND 52). SN 85-053,263. PUB. 6-7-2011. FILED 6-2-2010.
- 4,014,761. **GWIPES (STANDARD CHARACTER)**. DOWN TO EARTH DESIGNS, INC., (U.S. CLS. 1, 4, 6, 50, 51 AND 52). SN 85-062,583. PUB. 6-7-2011. FILED 6-14-2010.
- 4,014,772. **YAROK FOOD FOR YOUR HEAD. GOOD FOR THE EARTH. AND DESIGN**. YAROK LLC, (U.S. CLS. 1, 4, 6, 50, 51 AND 52). SN 85-065,170. PUB. 6-7-2011. FILED 6-17-2010.
- 4,014,801. **SEALKOTE (STANDARD CHARACTER)**. SIMONIZ USA, INC., (U.S. CLS. 1, 4, 6, 50, 51 AND 52). SN 85-071,512. PUB. 6-7-2011. FILED 6-25-2010.
- 4,014,825. **EQUIFUSE (STYLIZED)**. EQUIFUSE, (U.S. CLS. 1, 4, 6, 50, 51 AND 52). SN 85-076,033. PUB. 6-7-2011. FILED 7-1-2010.
- 4,014,846. **IREX (STANDARD CHARACTER)**. INDUSTRIAL LA FAMA, S.A. DE C.V., (U.S. CLS. 1, 4, 6, 50, 51 AND 52). SN 85-080,134. PUB. 6-7-2011. FILED 7-8-2010.
- 4,014,868 (*See Class 1 for this trademark*).
- 4,014,892. **NEOVADIOL (STANDARD CHARACTER)**. L'ORÉAL, (U.S. CLS. 1, 4, 6, 50, 51 AND 52). SN 85-090,304. PUB. 6-7-2011. FILED 7-22-2010.
- 4,014,897. **SUNOLOGY (STANDARD CHARACTER)**. MCNABB NUTRACEUTICALS, LLC, (U.S. CLS. 1, 4, 6, 50, 51 AND 52). SN 85-091,780. PUB. 6-7-2011. FILED 7-23-2010.
- 4,014,915 (*See Class 2 for this trademark*).
- 4,014,975. **PIGMENT BAR (STANDARD CHARACTER)**. PHYSICIANS CARE ALLIANCE, LLC, (U.S. CLS. 1, 4, 6, 50, 51 AND 52). SN 85-109,658. PUB. 6-7-2011. FILED 8-17-2010.
- 4,015,011. **HOLISTIC VANITY (STANDARD CHARACTER)**. PURE + SIMPLE BEAUTY INCORPORATED, (U.S. CLS. 1, 4, 6, 50, 51 AND 52). SN 85-121,776. PUB. 6-7-2011. FILED 9-2-2010.
- 4,015,027. **LYNETTE ARLENE MAKE UP ART (STANDARD CHARACTER)**. LYNETTE ARLENE SEYFERT, AKA LYNETTE ARLENE, (U.S. CLS. 1, 4, 6, 50, 51 AND 52). SN 85-125,498. PUB. 3-1-2011. FILED 9-8-2010.
- 4,015,030. **UNIMELA (STANDARD CHARACTER)**. PIERRE FABRE DERMO-COSMETIQUE, MULTIPLE CLASS, (INT. CLS. 3 AND 5), (U.S. CLS. 1, 4, 6, 18, 44, 46, 50, 51 AND 52). SN 85-126,034. PUB. 6-7-2011. FILED 9-9-2010.
- 4,015,033. **JEROME MOMENTS (STANDARD CHARACTER)**. PERFUMANIA, INC., MULTIPLE CLASS, (INT. CLS. 3 AND 4), (U.S. CLS. 1, 4, 6, 15, 50, 51 AND 52). SN 85-126,932. PUB. 3-1-2011. FILED 9-10-2010.
- 4,015,117. **EARTHLY BODY (STANDARD CHARACTER)**. EARTHLY BODY, INC., (U.S. CLS. 1, 4, 6, 50, 51 AND 52). SN 85-153,728. PUB. 6-7-2011. FILED 10-15-2010.
- 4,015,123. **AFT XC (STANDARD CHARACTER)**. SPA DE SOLEIL, INC., (U.S. CLS. 1, 4, 6, 50, 51 AND 52). SN 85-154,986. PUB. 6-7-2011. FILED 10-18-2010.
- 4,015,126. **CCX CELFIX COSMECEUTICALS AND DESIGN**. CAREFREE SKINCARE, (U.S. CLS. 1, 4, 6, 50, 51 AND 52). SN 85-155,498. PUB. 6-7-2011. FILED 10-18-2010.
- 4,015,187. **RAD (STANDARD CHARACTER)**. RAD COSMETICS LTD., (U.S. CLS. 1, 4, 6, 50, 51 AND 52). SN 85-174,799. PUB. 6-7-2011. FILED 11-11-2010.
- 4,015,415. **GLOBALLY AWARE SKIN CARE (STANDARD CHARACTER)**. JACARA LLC, DBA JACARA THERAPEUTIC SKIN CARE, (U.S. CLS. 1, 4, 6, 50, 51 AND 52). SN 85-214,526. PUB. 6-7-2011. FILED 1-10-2011.
- 4,015,452. **BRONSON (STANDARD CHARACTER)**. BRONSON NUTRITIONALS, LLC, MULTIPLE CLASS, (INT. CLS. 3, 5 AND 35), (U.S. CLS. 1, 4, 6, 18, 44, 46, 50, 51, 52, 100, 101 AND 102). SN 85-217,049. PUB. 6-7-2011. FILED 1-13-2011.
- 4,015,458. **UMOJA VISIONS, INC. AND DESIGN**. JOHN A. SMITH, DBA UMOJA VISIONS, (U.S. CLS. 1, 4, 6, 50, 51 AND 52). SN 85-217,435. PUB. 6-7-2011. FILED 1-13-2011.
- 4,015,469. **COLABS INTL. KLENSKIN AND DESIGN**. COLABS INT'L CORP., (U.S. CLS. 1, 4, 6, 50, 51 AND 52). SN 85-217,901. PUB. 6-7-2011. FILED 1-14-2011.
- 4,015,478. **PARFUMS DE LAROMA (STANDARD CHARACTER)**. CR TRADING COMPANY, INC., DBA TOP FRAGRANCES CORPORATION, (U.S. CLS. 1, 4, 6, 50, 51 AND 52). SN 85-218,528. PUB. 6-7-2011. FILED 1-14-2011.
- 4,015,555. **ROBO CLEAN (STANDARD CHARACTER)**. A.V.W. INC., DBA MAX PROFESSIONAL, (U.S. CLS. 1, 4, 6, 50, 51 AND 52). SN 85-220,979. PUB. 6-7-2011. FILED 1-19-2011.
- 4,015,644. **DAGNY & LANE AND DESIGN**. PELERIN INTERNATIONAL LLC., DBA DAGNY & LANE, MULTIPLE CLASS, (INT. CLS. 3 AND 4), (U.S. CLS. 1, 4, 6, 15, 50, 51 AND 52). SN 85-223,245. PUB. 6-7-2011. FILED 1-21-2011.
- 4,015,672. **JUNK WASH (STANDARD CHARACTER)**. CASEMOE INCORPORATED, (U.S. CLS. 1, 4, 6, 50, 51 AND 52). SN 85-225,040. PUB. 6-7-2011. FILED 1-24-2011.
- 4,015,741. **BREAKFREE (STANDARD CHARACTER)**. STRENGTH OF NATURE, LLC, (U.S. CLS. 1, 4, 6, 50, 51 AND 52). SN 85-228,502. PUB. 6-7-2011. FILED 1-28-2011.
- 4,015,742. **MEGA GROWTH (STANDARD CHARACTER)**. STRENGTH OF NATURE, LLC, (U.S. CLS. 1, 4, 6, 50, 51 AND 52). SN 85-228,510. PUB. 6-7-2011. FILED 1-28-2011.
- 4,015,759. **SEPTIDERM-V (STANDARD CHARACTER)**. GARMON CORPORATION, MULTIPLE CLASS, (INT. CLS. 3 AND 5), (U.S. CLS. 1, 4, 6, 18, 44, 46, 50, 51 AND 52). SN 85-228,776. PUB. 6-7-2011. FILED 1-28-2011.
- 4,015,801. **KERATIN CURE (STANDARD CHARACTER)**. BEAUTY COSMETICA, CORP., (U.S. CLS. 1, 4, 6, 50, 51 AND 52). SN 85-229,332. PUB. 6-7-2011. FILED 1-28-2011.
- 4,015,807. **HARMONY IV (STANDARD CHARACTER)**. SACRED ESSENCE ENTERPRISES LLC, (U.S. CLS. 1, 4, 6, 50, 51 AND 52). SN 85-229,423. PUB. 6-7-2011. FILED 1-29-2011.
- 4,015,846. **CALISTA CALISTACOSMETICS.COM AND DESIGN**. CALISTA COSMETICS, (U.S. CLS. 1, 4, 6, 50, 51 AND 52). SN 85-229,964. PUB. 6-7-2011. FILED 1-31-2011.
- 4,015,856. **LONOX (STANDARD CHARACTER)**. KYZEN CORPORATION, (U.S. CLS. 1, 4, 6, 50, 51 AND 52). SN 85-230,102. PUB. 6-7-2011. FILED 1-31-2011.
- 4,015,884. **MICRONAGE (STANDARD CHARACTER)**. SKINLUMA, LLC, MULTIPLE CLASS, (INT. CLS. 3 AND 5), (U.S. CLS. 1, 4, 6, 18, 44, 46, 50, 51 AND 52). SN 85-230,608. PUB. 6-7-2011. FILED 1-31-2011.
- 4,015,885. **QUELAGE (STANDARD CHARACTER)**. SKINLUMA, LLC, MULTIPLE CLASS, (INT. CLS. 3 AND 5), (U.S. CLS. 1, 4, 6, 18, 44, 46, 50, 51 AND 52). SN 85-230,619. PUB. 6-7-2011. FILED 1-31-2011.
- 4,015,887. **REVIAGE (STANDARD CHARACTER)**. SKINLUMA, LLC, MULTIPLE CLASS, (INT. CLS. 3 AND 5), (U.S. CLS. 1, 4, 6, 18, 44, 46, 50, 51 AND 52). SN 85-230,630. PUB. 6-7-2011. FILED 1-31-2011.
- 4,015,901. **KAHUNA ORGANICS (STANDARD CHARACTER)**. FITZPATRICK, MICHAEL JOSEPH, (U.S. CLS. 1, 4, 6, 50, 51

- AND 52). SN 85-230,891. PUB. 6-7-2011. FILED 2-1-2011.
- 4,015,929. **ROBO WASH (STANDARD CHARACTER)**. A.V.W. INC, DBA MAX PROFESSIONAL, (U.S. CLS. 1, 4, 6, 50, 51 AND 52). SN 85-231,208. PUB. 6-7-2011. FILED 2-1-2011.
- 4,015,958. **AN EDUCATED APPROACH TO MAKE-UP (STANDARD CHARACTER)**. MAKE-UP DESIGNORY, MULTIPLE CLASS, (INT. CLS. 3, 21 AND 41). (U.S. CLS. 1, 2, 4, 6, 13, 23, 29, 30, 33, 40, 50, 51, 52, 100, 101 AND 107). SN 85-231,759. PUB. 6-7-2011. FILED 2-1-2011.
- 4,016,058. **UD (STANDARD CHARACTER)**. URBAN DECAY COSMETICS LLC, (U.S. CLS. 1, 4, 6, 50, 51 AND 52). SN 85-234,652. PUB. 6-7-2011. FILED 2-4-2011.
- 4,016,064. **LIP JUNKIE (STANDARD CHARACTER)**. URBAN DECAY COSMETICS LLC, (U.S. CLS. 1, 4, 6, 50, 51 AND 52). SN 85-237,798. PUB. 6-7-2011. FILED 2-9-2011.
- 4,016,091. **REAL - PINE LEMON (STYLIZED)**. INDUSTRIAS ALEN, S.A. DE C.V., (U.S. CLS. 1, 4, 6, 50, 51 AND 52). SN 85-249,102. PUB. 6-7-2011. FILED 2-23-2011.
- 4,016,099. **SIMPLE. BRITE. WHITE. (STANDARD CHARACTER)**. CAO GROUP, INC., (U.S. CLS. 1, 4, 6, 50, 51 AND 52). SN 85-251,805. PUB. 6-7-2011. FILED 2-25-2011.
- 4,016,142. **GG (STYLIZED)**. PACIFIC WORLD CORPORATION, (U.S. CLS. 1, 4, 6, 50, 51 AND 52). SN 85-975,171. PUB. 6-7-2011. FILED 2-8-2011.

CLASS 4—LUBRICANTS AND FUELS

- 4,014,231. **AEROTAP (STANDARD CHARACTER)**. HARRY MILLER CORP., (U.S. CLS. 1, 6 AND 15). SN 76-706,217. PUB. 6-7-2011. FILED 2-1-2011.
- 4,014,232. **AEROKUT (STANDARD CHARACTER)**. HARRY MILLER CORP., (U.S. CLS. 1, 6 AND 15). SN 76-706,218. PUB. 6-7-2011. FILED 2-1-2011.
- 4,014,236. **AEROGRIND (STANDARD CHARACTER)**. HARRY MILLER CORP., (U.S. CLS. 1, 6 AND 15). SN 76-706,224. PUB. 6-7-2011. FILED 2-1-2011.
- 4,014,468. **AQUAVIGNO AND DESIGN**. LIDL STIFTUNG & CO. KG, MULTIPLE CLASS, (INT. CLS. 4, 6, 11, 20, 21, 22, 24, 25 AND 27). (U.S. CLS. 1, 2, 6, 7, 12, 13, 14, 15, 19, 20, 21, 22, 23, 25, 29, 30, 31, 32, 33, 34, 37, 39, 40, 42 AND 50). SN 79-078,283. PUB. 6-7-2011. FILED 11-10-2009.
- 4,014,486. **WTOKMAH AND DESIGN**. SHTOKMAN DEVELOPMENT AG, MULTIPLE CLASS, (INT. CLS. 4, 7, 9, 12, 35, 37, 39 AND 42). (U.S. CLS. 1, 6, 13, 15, 19, 21, 23, 26, 31, 34, 35, 36, 38, 44, 100, 101, 102, 103, 105 AND 106). SN 79-081,015. PUB. 6-7-2011. FILED 6-23-2009.
- 4,014,555 (*See Class 1 for this trademark*).
- 4,014,641 (*See Class 1 for this trademark*).
- 4,014,776 (*See Class 1 for this trademark*).
- 4,014,901. **GRILLAGAS (STANDARD CHARACTER)**. GRILLAGAS LLC, (U.S. CLS. 1, 6 AND 15). SN 85-092,709. PUB. 6-7-2011. FILED 7-26-2010.
- 4,014,902. **GRILLAGAS GAS FOR YOUR GRILL AND DESIGN**. GRILLAGAS LLC, (U.S. CLS. 1, 6 AND 15). SN 85-092,713. PUB. 6-7-2011. FILED 7-26-2010.
- 4,015,033 (*See Class 3 for this trademark*).
- 4,015,104. **PETROCARD AND DESIGN**. PETROCARD INC., (U.S. CLS. 1, 6 AND 15). SN 85-148,840. PUB. 6-7-2011. FILED 10-8-2010.
- 4,015,125. **SQUEEZE SCENTS (STANDARD CHARACTER)**. MITCHELL, CRAIG, (U.S. CLS. 1, 6 AND 15). SN 85-155,172. PUB. 6-7-2011. FILED 10-18-2010.
- 4,015,380. **TLC CANDLE (STANDARD CHARACTER)**. MVP GROUP INTERNATIONAL, INC., (U.S. CLS. 1, 6 AND 15). SN 85-211,003. PUB. 6-7-2011. FILED 1-5-2011.
- 4,015,594. **COGENT FIBRE (STANDARD CHARACTER)**. COGENT FIBRE INC., MULTIPLE CLASS, (INT. CLS. 4, 31, 35 AND 39). (U.S. CLS. 1, 6, 15, 46, 100, 101, 102 AND 105). SN 85-221,854. PUB. 6-7-2011. FILED 1-20-2011.
- 4,015,596. **COGENT FIBRE AND DESIGN**. COGENT FIBRE INC., MULTIPLE CLASS, (INT. CLS. 4, 31, 35 AND 39). (U.S. CLS. 1, 6, 15, 46, 100, 101, 102 AND 105). SN 85-221,860. PUB. 6-7-2011. FILED 1-20-2011.
- 4,015,644 (*See Class 3 for this trademark*).
- 4,015,752. **EXPLORER (STANDARD CHARACTER)**. OLYMPIC OIL, LTD., (U.S. CLS. 1, 6 AND 15). SN 85-228,700. PUB.

- 6-7-2011. FILED 1-28-2011.
- 4,015,781. **SAF-T-COOL (STANDARD CHARACTER)**. TOWER OIL & TECHNOLOGY CO., DBA TOWER OIL & TECHNOLOGY CO., (U.S. CLS. 1, 6 AND 15). SN 85-229,052. PUB. 6-7-2011. FILED 1-28-2011.
- 4,015,785. **BIG STAR (STANDARD CHARACTER)**. JOHNSON OIL COMPANY, (U.S. CLS. 1, 6 AND 15). SN 85-229,073. PUB. 6-7-2011. FILED 1-28-2011.
- 4,015,808. **IMMACULATE FLAME (STANDARD CHARACTER)**. MARY G. RAGO, DBA MARA PHOTOGRAPHY, (U.S. CLS. 1, 6 AND 15). SN 85-229,428. PUB. 6-7-2011. FILED 1-29-2011.

CLASS 5—PHARMACEUTICALS

- 4,014,209. **EPIFLUR (STANDARD CHARACTER)**. EPIC PHARMA, LLC, (U.S. CLS. 6, 18, 44, 46, 51 AND 52). SN 76-702,914. PUB. 6-7-2011. FILED 5-12-2010.
- 4,014,306. **X-PRESSO MONSTER (STANDARD CHARACTER)**. HANSEN BEVERAGE COMPANY, MULTIPLE CLASS, (INT. CLS. 5 AND 32). (U.S. CLS. 6, 18, 44, 45, 46, 48, 51 AND 52). SN 77-732,604. PUB. 6-7-2011. FILED 5-8-2009.
- 4,014,320 (*See Class 1 for this trademark*).
- 4,014,327 (*See Class 3 for this trademark*).
- 4,014,350 (*See Class 3 for this trademark*).
- 4,014,354. **MISCELLANEOUS DESIGN**. 4LIFE TRADEMARKS, LLC, (U.S. CLS. 6, 18, 44, 46, 51 AND 52). SN 77-862,976. PUB. 6-7-2011. FILED 11-2-2009.
- 4,014,457. **SEMPERSAN (STANDARD CHARACTER)**. S.U.K. BETEILIGUNGS GMBH, MULTIPLE CLASS, (INT. CLS. 5, 29 AND 30). (U.S. CLS. 6, 18, 44, 46, 51 AND 52). SN 79-071,494. PUB. 6-7-2011. FILED 11-28-2008.
- 4,014,460 (*See Class 1 for this trademark*).
- 4,014,469 (*See Class 1 for this trademark*).
- 4,014,513. **VETFLURANE (STANDARD CHARACTER)**. VIRBAC, (U.S. CLS. 6, 18, 44, 46, 51 AND 52). SN 79-084,799. PUB. 6-7-2011. FILED 5-31-2010.
- 4,014,519. **EASYGLASS (STANDARD CHARACTER)**. VOCO GMBH, (U.S. CLS. 6, 18, 44, 46, 51 AND 52). SN 79-085,227. PUB. 6-7-2011. FILED 6-14-2010.
- 4,014,525 (*See Class 1 for this trademark*).
- 4,014,590. **AGEXP (STANDARD CHARACTER)**. OBCHTCH-ESTVO S OGRANICHENNOY OTVETSTVENNOST'YU "VILAVI", (U.S. CLS. 6, 18, 44, 46, 51 AND 52). SN 79-089,368. PUB. 6-7-2011. FILED 9-22-2010.
- 4,014,604 (*See Class 1 for this trademark*).
- 4,014,606 (*See Class 3 for this trademark*).
- 4,014,612 (*See Class 3 for this trademark*).
- 4,014,613 (*See Class 3 for this trademark*).
- 4,014,633. **MISCELLANEOUS DESIGN**. CHAFFRINGEON BERNARD, (U.S. CLS. 6, 18, 44, 46, 51 AND 52). SN 79-092,180. PUB. 6-7-2011. FILED 9-15-2010.
- 4,014,635 (*See Class 1 for this trademark*).
- 4,014,651. **OVOTIQ (STANDARD CHARACTER)**. BOEHRINGER INGELHEIM INTERNATIONAL GMBH, (U.S. CLS. 6, 18, 44, 46, 51 AND 52). SN 79-095,472. PUB. 6-7-2011. FILED 2-23-2011.
- 4,014,652. **POTENOVE (STANDARD CHARACTER)**. BOEHRINGER INGELHEIM INTERNATIONAL GMBH, (U.S. CLS. 6, 18, 44, 46, 51 AND 52). SN 79-095,473. PUB. 6-7-2011. FILED 2-23-2011.
- 4,014,653. **PLYKANZA (STANDARD CHARACTER)**. BOEHRINGER INGELHEIM INTERNATIONAL GMBH, (U.S. CLS. 6, 18, 44, 46, 51 AND 52). SN 79-095,474. PUB. 6-7-2011. FILED 2-23-2011.
- 4,014,654. **PLYKYB (STANDARD CHARACTER)**. BOEHRINGER INGELHEIM INTERNATIONAL GMBH, (U.S. CLS. 6, 18, 44, 46, 51 AND 52). SN 79-095,475. PUB. 6-7-2011. FILED 2-23-2011.
- 4,014,655. **PAKNAURO (STANDARD CHARACTER)**. BOEHRINGER INGELHEIM INTERNATIONAL GMBH, (U.S. CLS. 6, 18, 44, 46, 51 AND 52). SN 79-095,476. PUB. 6-7-2011. FILED 2-23-2011.
- 4,014,656. **ZEUSPRIO (STANDARD CHARACTER)**. BOEHRINGER INGELHEIM INTERNATIONAL GMBH, (U.S.

- CLS. 6, 18, 44, 46, 51 AND 52). SN 79-095,477. PUB. 6-7-2011. FILED 2-23-2011.
- 4,014,657. **KEDARMO (STANDARD CHARACTER)**. BOEHRINGER INGELHEIM INTERNATIONAL GMBH, (U.S. CLS. 6, 18, 44, 46, 51 AND 52). SN 79-095,478. PUB. 6-7-2011. FILED 2-23-2011.
- 4,014,658. **POLKEMA (STANDARD CHARACTER)**. BOEHRINGER INGELHEIM INTERNATIONAL GMBH, (U.S. CLS. 6, 18, 44, 46, 51 AND 52). SN 79-095,479. PUB. 6-7-2011. FILED 2-23-2011.
- 4,014,659. **QUANZARO (STANDARD CHARACTER)**. BOEHRINGER INGELHEIM INTERNATIONAL GMBH, (U.S. CLS. 6, 18, 44, 46, 51 AND 52). SN 79-095,480. PUB. 6-7-2011. FILED 2-23-2011.
- 4,014,660. **VOLAZZO (STANDARD CHARACTER)**. BOEHRINGER INGELHEIM INTERNATIONAL GMBH, (U.S. CLS. 6, 18, 44, 46, 51 AND 52). SN 79-095,603. PUB. 6-7-2011. FILED 2-21-2011.
- 4,014,661. **VOLBRAVA (STANDARD CHARACTER)**. BOEHRINGER INGELHEIM INTERNATIONAL GMBH, (U.S. CLS. 6, 18, 44, 46, 51 AND 52). SN 79-095,604. PUB. 6-7-2011. FILED 2-21-2011.
- 4,014,662. **VOSIRBA (STANDARD CHARACTER)**. BOEHRINGER INGELHEIM INTERNATIONAL GMBH, (U.S. CLS. 6, 18, 44, 46, 51 AND 52). SN 79-095,605. PUB. 6-7-2011. FILED 2-21-2011.
- 4,014,663. **XOSEMYA (STANDARD CHARACTER)**. BOEHRINGER INGELHEIM INTERNATIONAL GMBH, (U.S. CLS. 6, 18, 44, 46, 51 AND 52). SN 79-095,606. PUB. 6-7-2011. FILED 2-21-2011.
- 4,014,665. **ZENPOLADE (STANDARD CHARACTER)**. BOEHRINGER INGELHEIM INTERNATIONAL GMBH, (U.S. CLS. 6, 18, 44, 46, 51 AND 52). SN 79-095,781. PUB. 6-7-2011. FILED 2-21-2011.
- 4,014,669. **SIGNIDERO (STANDARD CHARACTER)**. BOEHRINGER INGELHEIM INTERNATIONAL GMBH, (U.S. CLS. 6, 18, 44, 46, 51 AND 52). SN 79-095,950. PUB. 6-7-2011. FILED 10-20-2010.
- 4,014,695. **PERFORMENS AND DESIGN**. RUVALCABA LARA, CELIA ALEJANDRA, (U.S. CLS. 6, 18, 44, 46, 51 AND 52). SN 85-034,726. PUB. 6-7-2011. FILED 5-10-2010.
- 4,014,702 (*See Class 3 for this trademark*).
- 4,014,787. **CELGENE THALIDOMIDE AND DESIGN**. CELGENE CORPORATION, (U.S. CLS. 6, 18, 44, 46, 51 AND 52). SN 85-067,820. PUB. 6-7-2011. FILED 6-21-2010.
- 4,014,789. **SEA VEGGY TAILS (STANDARD CHARACTER)**. FARMASEA HEALTH LLC, (U.S. CLS. 6, 18, 44, 46, 51 AND 52). SN 85-069,130. PUB. 6-7-2011. FILED 6-22-2010.
- 4,014,791. **ALLOMEM (STANDARD CHARACTER)**. PROXY BIOMEDICAL LIMITED, MULTIPLE CLASS, (INT. CLS. 5, 10 AND 42), (U.S. CLS. 6, 18, 26, 39, 44, 46, 51, 52, 100 AND 101). SN 85-069,280. PUB. 6-7-2011. FILED 6-23-2010.
- 4,014,792. **XENOMEM (STANDARD CHARACTER)**. PROXY BIOMEDICAL LIMITED, MULTIPLE CLASS, (INT. CLS. 5, 10 AND 42), (U.S. CLS. 6, 18, 26, 39, 44, 46, 51, 52, 100 AND 101). SN 85-069,283. PUB. 6-7-2011. FILED 6-23-2010.
- 4,014,812. **ELLA'S (STANDARD CHARACTER)**. ELLA'S KITCHEN (IP) LIMITED, MULTIPLE CLASS, (INT. CLS. 5, 29, 30 AND 32), (U.S. CLS. 6, 18, 44, 45, 46, 48, 51 AND 52). SN 85-074,357. PUB. 6-7-2011. FILED 6-29-2010.
- 4,014,869. **BLA (STANDARD CHARACTER)**. KEBD ENTERPRISES, LLC, (U.S. CLS. 6, 18, 44, 46, 51 AND 52). SN 85-085,690. PUB. 6-7-2011. FILED 7-15-2010.
- 4,014,871. **JOMAX HORSE SNAX (STANDARD CHARACTER)**. MCDONNELL, JOANNE MARY, DBA JOMAX EQUINE PRODUCTS PTY LTD, MULTIPLE CLASS, (INT. CLS. 5 AND 31), (U.S. CLS. 1, 6, 18, 44, 46, 51 AND 52). SN 85-086,041. PUB. 6-7-2011. FILED 7-15-2010.
- 4,014,880. **HAMIDA PHARMA (STANDARD CHARACTER)**. HAMIDA PHARMA, INC, (U.S. CLS. 6, 18, 44, 46, 51 AND 52). SN 85-087,843. PUB. 6-7-2011. FILED 7-19-2010.
- 4,015,030 (*See Class 3 for this trademark*).
- 4,015,035. **DETOX-KIT AND DESIGN**. BIOLOGISCHE HEILMITTEL HEEL GMBH, (U.S. CLS. 6, 18, 44, 46, 51 AND 52). SN 85-127,302. PUB. 6-7-2011. FILED 9-10-2010.
- 4,015,054. **NATUREPLEX AND DESIGN**. NATUREPLEX, LLC, (U.S. CLS. 6, 18, 44, 46, 51 AND 52). SN 85-135,256. PUB. 6-7-2011. FILED 9-22-2010.
- 4,015,122. **AFTAZEN (STANDARD CHARACTER)**. PREVIZEN SAS, (U.S. CLS. 6, 18, 44, 46, 51 AND 52). SN 85-154,690. PUB. 6-7-2011. FILED 10-18-2010.
- 4,015,154. **ZOKLIK (STANDARD CHARACTER)**. HOECHST GMBH, MULTIPLE CLASS, (INT. CLS. 5 AND 10), (U.S. CLS. 6, 18, 26, 39, 44, 46, 51 AND 52). SN 85-164,518. PUB. 6-7-2011. FILED 10-29-2010.
- 4,015,156. **NATUREPLEX (STANDARD CHARACTER)**. NATUREPLEX, LLC, (U.S. CLS. 6, 18, 44, 46, 51 AND 52). SN 85-165,502. PUB. 6-7-2011. FILED 10-30-2010.
- 4,015,235. **PULSIN' AND DESIGN**. PULSIN' LTD, MULTIPLE CLASS, (INT. CLS. 5 AND 29), (U.S. CLS. 6, 18, 44, 46, 51 AND 52). SN 85-187,905. PUB. 6-7-2011. FILED 12-1-2010.
- 4,015,269. **VITALITY CALCIUM COMPLETE (STANDARD CHARACTER)**. MELALEUCA, INC., (U.S. CLS. 6, 18, 44, 46, 51 AND 52). SN 85-195,477. PUB. 6-7-2011. FILED 12-10-2010.
- 4,015,290. **LO LOESTRIN FE AND DESIGN**. WARNER CHILCOTT COMPANY, LLC, (U.S. CLS. 6, 18, 44, 46, 51 AND 52). SN 85-198,440. PUB. 6-7-2011. FILED 12-15-2010.
- 4,015,309. **EN (STYLIZED)**. ENFORCE NUTRITION, LLC, (U.S. CLS. 6, 18, 44, 46, 51 AND 52). SN 85-201,983. PUB. 6-7-2011. FILED 12-20-2010.
- 4,015,452 (*See Class 3 for this trademark*).
- 4,015,457. **FUN GUY (STANDARD CHARACTER)**. SUREFED, LTD., (U.S. CLS. 6, 18, 44, 46, 51 AND 52). SN 85-217,323. PUB. 6-7-2011. FILED 1-13-2011.
- 4,015,479. **SEXXY SCENTS (STANDARD CHARACTER)**. KADIDA GASKINS, DBA SEXXY SCENTS, (U.S. CLS. 6, 18, 44, 46, 51 AND 52). SN 85-218,579. PUB. 6-7-2011. FILED 1-14-2011.
- 4,015,654. **ELIMAY AND DESIGN**. SRS PHARMACEUTICALS PVT. LTD., (U.S. CLS. 6, 18, 44, 46, 51 AND 52). SN 85-224,017. PUB. 6-7-2011. FILED 1-23-2011.
- 4,015,686. **TEBUCON (STANDARD CHARACTER)**. REPAR CORPORATION, (U.S. CLS. 6, 18, 44, 46, 51 AND 52). SN 85-226,164. PUB. 6-7-2011. FILED 1-25-2011.
- 4,015,687 (*See Class 1 for this trademark*).
- 4,015,693. **TRANSDERM SCOP (STANDARD CHARACTER)**. NOVARTIS AG, (U.S. CLS. 6, 18, 44, 46, 51 AND 52). SN 85-226,547. PUB. 6-7-2011. FILED 1-26-2011.
- 4,015,696. **TRANSDERM SCOP AND DESIGN**. NOVARTIS AG, (U.S. CLS. 6, 18, 44, 46, 51 AND 52). SN 85-226,606. PUB. 6-7-2011. FILED 1-26-2011.
- 4,015,701. **ALCORTIN A (STANDARD CHARACTER)**. PRIMUS PHARMACEUTICALS, INC., (U.S. CLS. 6, 18, 44, 46, 51 AND 52). SN 85-226,797. PUB. 6-7-2011. FILED 1-26-2011.
- 4,015,759 (*See Class 3 for this trademark*).
- 4,015,771. **VISIONSAVE (STANDARD CHARACTER)**. SUPPLEMENT FIRST, DBA SUPPLEMENT FIRST, (U.S. CLS. 6, 18, 44, 46, 51 AND 52). SN 85-228,934. PUB. 6-7-2011. FILED 1-28-2011.
- 4,015,790. **LINEPHARMA (STANDARD CHARACTER)**. LINEPHARMA SARL, MULTIPLE CLASS, (INT. CLS. 5 AND 44), (U.S. CLS. 6, 18, 44, 46, 51, 52, 100 AND 101). SN 85-229,132. PUB. 6-7-2011. FILED 1-28-2011.
- 4,015,828 (*See Class 1 for this trademark*).
- 4,015,884 (*See Class 3 for this trademark*).
- 4,015,885 (*See Class 3 for this trademark*).
- 4,015,887 (*See Class 3 for this trademark*).
- 4,015,897. **CANKER SPANKER (STANDARD CHARACTER)**. SEAN SOLO LLC, (U.S. CLS. 6, 18, 44, 46, 51 AND 52). SN 85-230,786. PUB. 6-7-2011. FILED 2-1-2011.
- 4,015,980. **GOLDLYTE (STANDARD CHARACTER)**. BIO-VET, INC., (U.S. CLS. 6, 18, 44, 46, 51 AND 52). SN 85-232,239. PUB. 6-7-2011. FILED 2-2-2011.
- 4,016,004. **HEPATA*TROPE (STANDARD CHARACTER)**. SCIENTIFIC BIO-LOGICS, INC., (U.S. CLS. 6, 18, 44, 46, 51 AND 52). SN 85-232,639. PUB. 6-7-2011. FILED 2-2-2011.
- 4,016,012. **SULFA*DERM (STANDARD CHARACTER)**. SCIENTIFIC BIO-LOGICS, INC., (U.S. CLS. 6, 18, 44, 46, 51 AND 52). SN 85-232,704. PUB. 6-7-2011. FILED 2-2-2011.
- 4,016,044. **VIDAPURA (STANDARD CHARACTER)**. GOLDEN ISLES MEDICAL, INC., (U.S. CLS. 6, 18, 44, 46, 51 AND 52). SN 85-233,543. PUB. 6-7-2011. FILED 2-3-2011.
- 4,016,060. **NOVATEST (STANDARD CHARACTER)**. MAXIMUM HUMAN PERFORMANCE, LLC, (U.S. CLS. 6, 18, 44, 46, 51 AND 52). SN 85-235,765. PUB. 6-7-2011. FILED 2-7-2011.

- 4,016,063. **IF YOU'RE NOT FIRST, YOU'RE LAST! (STANDARD CHARACTER)**, MARK NORTHCUTT, (U.S. CLS. 6, 18, 44, 46, 51 AND 52). SN 85-237,763. PUB. 6-7-2011. FILED 2-9-2011.
- 4,016,100. **BLISSBOND (STANDARD CHARACTER)**, CAO GROUP, INC., (U.S. CLS. 6, 18, 44, 46, 51 AND 52). SN 85-252,038. PUB. 6-7-2011. FILED 2-25-2011.
- 4,016,101. **EASY. EFFECTIVE. PATIENT COMFORT. (STANDARD CHARACTER)**, CAO GROUP, INC., (U.S. CLS. 6, 18, 44, 46, 51 AND 52). SN 85-252,119. PUB. 6-7-2011. FILED 2-25-2011.
- 4,016,102. **MISCELLANEOUS DESIGN**, CITI FINANCIAL LENDING, INC., (U.S. CLS. 6, 18, 44, 46, 51 AND 52). SN 85-253,339. PUB. 6-7-2011. FILED S.R. 2-28-2011; AM. P.R. 3-8-2011.
- 4,016,125. **THE TWILIGHT SAGA (STANDARD CHARACTER)**, SUMMIT ENTERTAINMENT, LLC, (U.S. CLS. 6, 18, 44, 46, 51 AND 52). SN 85-279,289. PUB. 6-7-2011. FILED 3-29-2011.

CLASS 6—METAL GOODS

- 4,014,202. **BEVERAGE BUTLER (STANDARD CHARACTER)**, A1 PRICE ENTERPRISES ("A1 PRICE"), (U.S. CLS. 2, 12, 13, 14, 23, 25 AND 50). SN 76-692,898. PUB. 6-7-2011. FILED 9-16-2008.
- 4,014,311. **ARMOR INTERNATIONAL AND DESIGN**, ARMOR INTERNATIONAL S.A., MULTIPLE CLASS, (INT. CLS. 6 AND 9), (U.S. CLS. 2, 12, 13, 14, 21, 23, 25, 26, 36, 38 AND 50). SN 77-751,718. PUB. 6-7-2011. FILED 6-4-2009.
- 4,014,314. **ROSS (STANDARD CHARACTER)**, NEXUS INDUSTRIES LIMITED, MULTIPLE CLASS, (INT. CLS. 6, 9, 11 AND 20), (U.S. CLS. 2, 12, 13, 14, 21, 22, 23, 25, 26, 31, 32, 34, 36, 38 AND 50). SN 77-754,572. PUB. 6-7-2011. FILED 6-8-2009.
- 4,014,337. **RIGHT CARE RIGHT NOW AND DESIGN**, SOCIETY OF CRITICAL CARE MEDICINE, MULTIPLE CLASS, (INT. CLS. 6, 9, 16, 21, 25, 35, 41 AND 44), (U.S. CLS. 2, 5, 12, 13, 14, 21, 22, 23, 25, 26, 29, 30, 33, 36, 37, 38, 39, 40, 50, 100, 101, 102 AND 107). SN 77-824,942. PUB. 6-7-2011. FILED 9-11-2009.
- 4,014,452. **SCHENCKACCURATE AND DESIGN**, SCHENCK PROCESS GMBH, AND CARL SCHENCK AG, MULTIPLE CLASS, (INT. CLS. 6, 7, 9, 11, 12, 20 AND 42), (U.S. CLS. 2, 12, 13, 14, 19, 21, 22, 23, 25, 26, 31, 32, 34, 35, 36, 38, 44, 50, 100 AND 101). SN 79-062,323. PUB. 6-7-2011. FILED 12-18-2007.
- 4,014,468 (*See Class 4 for this trademark*).
- 4,014,485. **ASB (STANDARD CHARACTER)**, SYSTEMBAU HORST BABINSKY GMBH, MULTIPLE CLASS, (INT. CLS. 6, 19, 37 AND 42), (U.S. CLS. 1, 2, 12, 13, 14, 23, 25, 33, 50, 100, 101, 103 AND 106). SN 79-080,585. PUB. 6-7-2011. FILED 12-23-2009.
- 4,014,544. **NTG AND DESIGN**, NTG PLASTIK SANAYI VE TICARET ANONIM SIRKETI, MULTIPLE CLASS, (INT. CLS. 6, 17 AND 19), (U.S. CLS. 1, 2, 5, 12, 13, 14, 23, 25, 33, 35 AND 50). SN 79-086,575. PUB. 6-7-2011. FILED 3-29-2010.
- 4,014,572. **SEDULOUS (STYLIZED)**, NINGBO TONGYI METALWORK CO., LTD., (U.S. CLS. 2, 12, 13, 14, 23, 25 AND 50). SN 79-087,902. PUB. 6-7-2011. FILED 7-26-2010.
- 4,014,597. **GOLDEN LUYANG AND DESIGN**, SHANDONG GOLDEN LUYANG HEAVY INDUSTRY CO., LTD., (U.S. CLS. 2, 12, 13, 14, 23, 25 AND 50). SN 79-089,854. PUB. 6-7-2011. FILED 5-20-2010.
- 4,014,607. **MISCELLANEOUS DESIGN**, FOSHAN CITY NANHAI YONGFENG ALUMINIUM CO., LTD., (U.S. CLS. 2, 12, 13, 14, 23, 25 AND 50). SN 79-090,542. PUB. 6-7-2011. FILED 11-12-2010.
- 4,014,609. **UCERA (STANDARD CHARACTER)**, ISMAN J CORPORATION, MULTIPLE CLASS, (INT. CLS. 6, 7 AND 12), (U.S. CLS. 2, 12, 13, 14, 19, 21, 23, 25, 31, 34, 35, 44 AND 50). SN 79-090,605. PUB. 6-7-2011. FILED 10-29-2010.
- 4,014,625. **ABSCO (STANDARD CHARACTER)**, JOHN SCHOLTES INVESTMENTS (NO 1) PTY LTD, (U.S. CLS. 2, 12, 13, 14, 23, 25 AND 50). SN 79-091,418. PUB. 6-7-2011. FILED 11-8-2010.
- 4,014,731. **PASADENA CITY COLLEGE AND DESIGN**, PASA-

- DENA CITY COLLEGE, MULTIPLE CLASS, (INT. CLS. 6, 14, 16, 18, 21, 24, 25, 28, 38, 39 AND 41), (U.S. CLS. 1, 2, 3, 5, 12, 13, 14, 22, 23, 25, 27, 28, 29, 30, 33, 37, 38, 39, 40, 41, 42, 50, 100, 101, 104, 105 AND 107). SN 85-051,656. PUB. 6-7-2011. FILED 6-1-2010.
- 4,014,904. **VEN-MAR SALES, INC. AND DESIGN**, VEN-MAR SALES, INC., (U.S. CLS. 2, 12, 13, 14, 23, 25 AND 50). SN 85-092,837. PUB. 6-7-2011. FILED 7-26-2010.
- 4,014,912. **DIGI-KEY AND DESIGN**, DIGI-KEY CORPORATION, MULTIPLE CLASS, (INT. CLS. 6, 9, 17 AND 35), (U.S. CLS. 1, 2, 5, 12, 13, 14, 21, 23, 25, 26, 35, 36, 38, 50, 100, 101 AND 102). SN 85-094,006. PUB. 6-7-2011. FILED 7-27-2010.
- 4,014,924. **SECURED. SEALED. SAFE. (STANDARD CHARACTER)**, A.P.M. HEXSEAL CORPORATION, (U.S. CLS. 2, 12, 13, 14, 23, 25 AND 50). SN 85-095,589. PUB. 6-7-2011. FILED 7-29-2010.
- 4,015,009. **W WOLVERINE TUBE, INC. ENGINEERING THERMAL INNOVATION AND DESIGN**, WOLVERINE TUBE, INC., (U.S. CLS. 2, 12, 13, 14, 23, 25 AND 50). SN 85-121,512. PUB. 6-7-2011. FILED 9-2-2010.
- 4,015,022. **FF AND DESIGN**, FLEET WHOLESALE SUPPLY CO., INC., (U.S. CLS. 2, 12, 13, 14, 23, 25 AND 50). SN 85-123,697. PUB. 6-7-2011. FILED 9-7-2010.
- 4,015,144. **PLUMBER TESTED THE PRO'S CHOICE, AND DESIGN**, JONES STEPHENS CORPORATION, MULTIPLE CLASS, (INT. CLS. 6 AND 11), (U.S. CLS. 2, 12, 13, 14, 21, 23, 25, 31, 34 AND 50). SN 85-161,434. PUB. 6-7-2011. FILED 10-26-2010.
- 4,015,720. **DONGBU AND DESIGN**, DONGBU STEEL CO., LTD., (U.S. CLS. 2, 12, 13, 14, 23, 25 AND 50). SN 85-227,703. PUB. 6-7-2011. FILED 1-27-2011.
- 4,015,757. **USG CEILINGS (STANDARD CHARACTER)**, USG INTERIORS, INC., (U.S. CLS. 2, 12, 13, 14, 23, 25 AND 50). SN 85-228,751. PUB. 6-7-2011. FILED 1-28-2011.
- 4,015,816. **GUTTERMATE SYSTEM (STANDARD CHARACTER)**, GUTTERMATE SYSTEMS, LLC, (U.S. CLS. 2, 12, 13, 14, 23, 25 AND 50). SN 85-229,529. PUB. 6-7-2011. FILED 1-29-2011.

CLASS 7—MACHINERY

- 4,014,216. **SOLDER MEISTER (STANDARD CHARACTER)**, JAPAN UNIX CO., LTD., (U.S. CLS. 13, 19, 21, 23, 31, 34 AND 35). SN 76-703,826. PUB. 6-7-2011. FILED 7-19-2010.
- 4,014,235. **VERISTIC AND DESIGN**, VERISTIC TECHNOLOGIES, INC., (U.S. CLS. 13, 19, 21, 23, 31, 34 AND 35). SN 76-706,223. PUB. 6-7-2011. FILED 2-1-2011.
- 4,014,295. **FURION (STANDARD CHARACTER)**, PSK, INC., (U.S. CLS. 13, 19, 21, 23, 31, 34 AND 35). SN 77-680,283. PUB. 6-7-2011. FILED 2-27-2009.
- 4,014,296. **ZEROCHIP (STANDARD CHARACTER)**, MORI SEIKI CO., LTD., (U.S. CLS. 13, 19, 21, 23, 31, 34 AND 35). SN 77-684,751. PUB. 4-19-2011. FILED 3-5-2009.
- 4,014,322. **OVER-ACHIEVER (STANDARD CHARACTER)**, EAZYPOWER CORPORATION, MULTIPLE CLASS, (INT. CLS. 7 AND 8), (U.S. CLS. 13, 19, 21, 23, 28, 31, 34, 35 AND 44). SN 77-773,827. PUB. 6-7-2011. FILED 7-2-2009.
- 4,014,348. **DUAL FORCE (STANDARD CHARACTER)**, SCIAMMA, FREDERIC, MULTIPLE CLASS, (INT. CLS. 7, 35 AND 38), (U.S. CLS. 13, 19, 21, 23, 31, 34, 35, 100, 101, 102 AND 104). SN 77-857,410. PUB. 6-7-2011. FILED 10-26-2009.
- 4,014,429 (*See Class 3 for this trademark*).
- 4,014,432 (*See Class 3 for this trademark*).
- 4,014,450. **PH 6200 AND DESIGN**, SACMI COOPERATIVA MECCANICI IMOLA; SOCIETA' COOPERATIVA, (U.S. CLS. 13, 19, 21, 23, 31, 34 AND 35). SN 79-044,438. PUB. 6-7-2011. FILED 9-25-2007.
- 4,014,452 (*See Class 6 for this trademark*).
- 4,014,462. **FLEXLENS (STANDARD CHARACTER)**, WALDORF TECHNIK GMBH & CO. KG, (U.S. CLS. 13, 19, 21, 23, 31, 34 AND 35). SN 79-076,555. PUB. 6-7-2011. FILED 11-17-2009.
- 4,014,463. **LENSFLEX (STANDARD CHARACTER)**, WALDORF TECHNIK GMBH & CO. KG, (U.S. CLS. 13, 19, 21, 23, 31, 34 AND 35). SN 79-076,556. PUB. 6-7-2011. FILED 11-

- 17-2009.
- 4,014,466. **BEGEMANN (STANDARD CHARACTER)**. WEIR MINERALS NETHERLANDS B.V., (U.S. CLS. 13, 19, 21, 23, 31, 34 AND 35). SN 79-077,689. PUB. 6-7-2011. FILED 12-8-2009.
- 4,014,482. **LEWA TRIPLEX (STYLIZED)**. LEWA GMBH, MULTIPLE CLASS, (INT. CLS. 7 AND 9), (U.S. CLS. 13, 19, 21, 23, 26, 31, 34, 35, 36 AND 38). SN 79-079,768. PUB. 6-7-2011. FILED 12-1-2009.
- 4,014,486 (*See Class 4 for this trademark*).
- 4,014,488. **INPECO (STANDARD CHARACTER)**. INPECO SA, MULTIPLE CLASS, (INT. CLS. 7, 9 AND 10), (U.S. CLS. 13, 19, 21, 23, 26, 31, 34, 35, 36, 38, 39 AND 44). SN 79-081,200. PUB. 6-7-2011. FILED 12-15-2009.
- 4,014,493. **TORFLEX (STANDARD CHARACTER)**. HACKFORTH GMBH, MULTIPLE CLASS, (INT. CLS. 7, 12 AND 37), (U.S. CLS. 13, 19, 21, 23, 31, 34, 35, 44, 100, 103 AND 106). SN 79-082,430. PUB. 6-7-2011. FILED 1-21-2010.
- 4,014,506 (*See Class 1 for this trademark*).
- 4,014,511. **FIBRIX (STANDARD CHARACTER)**. BOBST SA, (U.S. CLS. 13, 19, 21, 23, 31, 34 AND 35). SN 79-084,636. PUB. 6-7-2011. FILED 6-25-2010.
- 4,014,516. **FUELWORKS (STYLIZED)**. INTRADIN (SHANGHAI) MACHINERY CO., LTD., MULTIPLE CLASS, (INT. CLS. 7 AND 9), (U.S. CLS. 13, 19, 21, 23, 26, 31, 34, 35, 36 AND 38). SN 79-085,118. PUB. 6-7-2011. FILED 7-1-2010.
- 4,014,520. **TWISTLOK (STANDARD CHARACTER)**. BRADKEN RESOURCES PTY LIMITED, (U.S. CLS. 13, 19, 21, 23, 31, 34 AND 35). SN 79-085,258. PUB. 6-7-2011. FILED 6-18-2010.
- 4,014,531. **ELEMEX (STANDARD CHARACTER)**. ATLAS COPCO CRAELIUS AB, MULTIPLE CLASS, (INT. CLS. 7 AND 37), (U.S. CLS. 13, 19, 21, 23, 31, 34, 35, 100, 103 AND 106). SN 79-085,709. PUB. 6-7-2011. FILED 3-4-2010.
- 4,014,532. **RMR AND DESIGN**. AGR SUBSEA AS, MULTIPLE CLASS, (INT. CLS. 7 AND 37), (U.S. CLS. 13, 19, 21, 23, 31, 34, 35, 100, 103 AND 106). SN 79-085,749. PUB. 6-7-2011. FILED 4-9-2010.
- 4,014,535. **METRIX (STANDARD CHARACTER)**. BOBST SA, (U.S. CLS. 13, 19, 21, 23, 31, 34 AND 35). SN 79-086,035. PUB. 6-7-2011. FILED 6-25-2010.
- 4,014,547. **NORRIDI (STANDARD CHARACTER)**. NORRHYDRO OY, MULTIPLE CLASS, (INT. CLS. 7, 9 AND 37), (U.S. CLS. 13, 19, 21, 23, 26, 31, 34, 35, 36, 38, 100, 103 AND 106). SN 79-086,706. PUB. 6-7-2011. FILED 6-17-2010.
- 4,014,563. **TILER (STYLIZED)**. HANG ZHOU JIE HAO GONG MAO YOU XIAN GONG SI, MULTIPLE CLASS, (INT. CLS. 7 AND 8), (U.S. CLS. 13, 19, 21, 23, 28, 31, 34, 35 AND 44). SN 79-087,316. PUB. 6-7-2011. FILED 6-29-2010.
- 4,014,568. **AVANTEC (STYLIZED)**. AVANTEC ZERSPANTECHNIK GMBH, (U.S. CLS. 13, 19, 21, 23, 31, 34 AND 35). SN 79-087,502. PUB. 6-7-2011. FILED 7-14-2010.
- 4,014,569. **CIBAS AND DESIGN**. TANJUNG CITECH UK LIMITED, MULTIPLE CLASS, (INT. CLS. 7 AND 11), (U.S. CLS. 13, 19, 21, 23, 31, 34 AND 35). SN 79-087,806. PUB. 6-7-2011. FILED 7-2-2010.
- 4,014,577. **TKR (STYLIZED)**. TKR SPEZIALWERKZEUGE GMBH, MULTIPLE CLASS, (INT. CLS. 7, 8, 9 AND 40), (U.S. CLS. 13, 19, 21, 23, 26, 28, 31, 34, 35, 36, 38, 44, 100, 103 AND 106). SN 79-088,300. PUB. 6-7-2011. FILED 1-29-2010.
- 4,014,578. **JOHN HART AND DESIGN**. TOMAIN INVESTMENTS PTY LIMITED, (U.S. CLS. 13, 19, 21, 23, 31, 34 AND 35). SN 79-088,324. PUB. 6-7-2011. FILED 4-19-2010.
- 4,014,609 (*See Class 6 for this trademark*).
- 4,014,616. **BCK (STYLIZED)**. WANHONG GROUP CO., LTD., (U.S. CLS. 13, 19, 21, 23, 31, 34 AND 35). SN 79-090,965. PUB. 6-7-2011. FILED 11-24-2010.
- 4,014,629. **SINCERE-HOME (STYLIZED)**. FOSHAN SHUNDE TALENT INDUSTRIAL CO., LTD., MULTIPLE CLASS, (INT. CLS. 7, 9 AND 11), (U.S. CLS. 13, 19, 21, 23, 26, 31, 34, 35, 36 AND 38). SN 79-091,855. PUB. 6-7-2011. FILED 11-25-2010.
- 4,014,631. **RKW (STANDARD CHARACTER)**. KUGEL- UND ROLLENLAGERWERK LEIPZIG GMBH, (U.S. CLS. 13, 19, 21, 23, 31, 34 AND 35). SN 79-092,016. PUB. 6-7-2011. FILED 11-25-2010.
- 4,014,648 (*See Class 3 for this trademark*).
- 4,014,810. **DDP DISCFLO DISC PUMPS AND DESIGN**. DISCFLO CORPORATION, (U.S. CLS. 13, 19, 21, 23, 31, 34 AND 35). SN 85-073,949. PUB. 6-7-2011. FILED 6-29-2010.
- 4,014,866. **EDBRO (STANDARD CHARACTER)**. EDBRO PLC, MULTIPLE CLASS, (INT. CLS. 7 AND 12), (U.S. CLS. 13, 19, 21, 23, 31, 34, 35 AND 44). SN 85-085,575. PUB. 6-7-2011. FILED 7-15-2010.
- 4,015,019. **ATLANTIC BLOWERS AND DESIGN**. ATLANTIC BLOWERS, (U.S. CLS. 13, 19, 21, 23, 31, 34 AND 35). SN 85-123,103. PUB. 6-7-2011. FILED 9-3-2010.
- 4,015,208. **ORIGINAL LINE (STANDARD CHARACTER)**. BIMBA MANUFACTURING COMPANY, (U.S. CLS. 13, 19, 21, 23, 31, 34 AND 35). SN 85-179,780. PUB. 6-7-2011. FILED 11-18-2010.
- 4,015,212. **RECIRCONE (STANDARD CHARACTER)**. PELLERIN MILNOR CORPORATION, (U.S. CLS. 13, 19, 21, 23, 31, 34 AND 35). SN 85-181,508. PUB. 6-7-2011. FILED 11-19-2010.
- 4,015,216. **SUPERSHEAR AND DESIGN**. SUPERSHEAR INC, (U.S. CLS. 13, 19, 21, 23, 31, 34 AND 35). SN 85-182,977. PUB. 6-7-2011. FILED 11-22-2010.
- 4,015,246. **CURTAIN CALL (STANDARD CHARACTER)**. WWW.REMOTECONTROLCURTAIN.COM, INC., DBA CURTAIN CALL, MULTIPLE CLASS, (INT. CLS. 7 AND 24), (U.S. CLS. 13, 19, 21, 23, 31, 34, 35, 42 AND 50). SN 85-189,850. PUB. 6-7-2011. FILED 12-3-2010.
- 4,015,346. **SIDAS TECHNOLOGIES (STANDARD CHARACTER)**. SOCIETE D'IMPORTATION DE DIFFUSION OU DISTRIBUTION D'ARTICLES DE SPORT S.I.D.A.S., MULTIPLE CLASS, (INT. CLS. 7, 10 AND 25), (U.S. CLS. 13, 19, 21, 22, 23, 26, 31, 34, 35, 39 AND 44). SN 85-206,973. PUB. 6-7-2011. FILED 12-29-2010.
- 4,015,358. **RACoon AND DESIGN**. ZHEJIANG HERO TIME MACHINERY CO., LTD., (U.S. CLS. 13, 19, 21, 23, 31, 34 AND 35). SN 85-208,374. PUB. 6-7-2011. FILED 12-30-2010.
- 4,015,382. **WILLY VAC (STANDARD CHARACTER)**. WALLACE, WILLIAM L., (U.S. CLS. 13, 19, 21, 23, 31, 34 AND 35). SN 85-211,204. PUB. 6-7-2011. FILED 1-5-2011.
- 4,015,409. **SUR LOC BAND AND DESIGN**. SAMAR COMPANY, INC., (U.S. CLS. 13, 19, 21, 23, 31, 34 AND 35). SN 85-214,077. PUB. 6-7-2011. FILED 1-10-2011.
- 4,015,432. **AIRLESSCO A (STYLIZED)**. GRACO MINNESOTA INC., (U.S. CLS. 13, 19, 21, 23, 31, 34 AND 35). SN 85-215,768. PUB. 6-7-2011. FILED 1-12-2011.
- 4,015,616. **GUTTER CLUTTER BUSTER (STANDARD CHARACTER)**. GUTTER CLUTTER BUSTER, LLC., (U.S. CLS. 13, 19, 21, 23, 31, 34 AND 35). SN 85-222,356. PUB. 6-7-2011. FILED 1-20-2011.
- 4,015,792. **DRYKEEP (STANDARD CHARACTER)**. ARDRY TRADING CO., INC., (U.S. CLS. 13, 19, 21, 23, 31, 34 AND 35). SN 85-229,173. PUB. 6-7-2011. FILED 1-28-2011.
- 4,015,814. **HDSM (STYLIZED)**. HYD-SYSTEM TECHNOLOGY CO. LTD., (U.S. CLS. 13, 19, 21, 23, 31, 34 AND 35). SN 85-229,524. PUB. 6-7-2011. FILED 1-29-2011.
- 4,015,871. **MINI-MC (STANDARD CHARACTER)**. MCELROY MANUFACTURING, INC., (U.S. CLS. 13, 19, 21, 23, 31, 34 AND 35). SN 85-230,438. PUB. 6-7-2011. FILED 1-31-2011.
- 4,015,874. **DYNAMC (STANDARD CHARACTER)**. MCELROY MANUFACTURING, INC., (U.S. CLS. 13, 19, 21, 23, 31, 34 AND 35). SN 85-230,480. PUB. 6-7-2011. FILED 1-31-2011.
- 4,015,877. **SIDEWINDER (STANDARD CHARACTER)**. MCELROY MANUFACTURING, INC., (U.S. CLS. 13, 19, 21, 23, 31, 34 AND 35). SN 85-230,515. PUB. 6-7-2011. FILED 1-31-2011.
- 4,015,896. **VANTA AND DESIGN**. GUANGZHOU VANTA PACKING MACHINERY CO., LTD., (U.S. CLS. 13, 19, 21, 23, 31, 34 AND 35). SN 85-230,783. PUB. 6-7-2011. FILED 2-1-2011.
- 4,016,120. **SHARK NAVIGATOR (STANDARD CHARACTER)**. EURO-PRO OPERATING LLC, (U.S. CLS. 13, 19, 21, 23, 31, 34 AND 35). SN 85-266,546. PUB. 6-7-2011. FILED 3-14-2011.

CLASS 8—HAND TOOLS

- 4,014,322 (*See Class 7 for this trademark*).
- 4,014,563 (*See Class 7 for this trademark*).
- 4,014,577 (*See Class 7 for this trademark*).

4,014,648 (*See Class 3 for this trademark.*)
 4,014,702 (*See Class 3 for this trademark.*)
 4,015,388. **WINGMASTER (STANDARD CHARACTER).** WINGMASTER PLUS, INC., (U.S. CLS. 23, 28 AND 44). SN 85-211,852. PUB. 6-7-2011. FILED 1-6-2011.
 4,015,951. **NAKATOMI (STANDARD CHARACTER).** PM PRO-TOOLS THE SOURCE, (U.S. CLS. 23, 28 AND 44). SN 85-231,641. PUB. 6-7-2011. FILED 2-1-2011.

CLASS 9—ELECTRICAL AND SCIENTIFIC APPARATUS

4,014,198. **DVD EXTRA AND DESIGN.** ZOOTECH LIMITED, MULTIPLE CLASS, (INT. CLS. 9 AND 42), (U.S. CLS. 21, 23, 26, 36, 38, 100 AND 101). SN 76-432,309. PUB. 6-7-2011. FILED 7-19-2002.
 4,014,214. **TACTICIAN PREPARE TO WIN (STANDARD CHARACTER).** TACTICIAN CORPORATION, MULTIPLE CLASS, (INT. CLS. 9 AND 35), (U.S. CLS. 21, 23, 26, 36, 38, 100, 101 AND 102). SN 76-703,618. PUB. 6-7-2011. FILED 7-2-2010.
 4,014,233. **GEOGEBRA (STANDARD CHARACTER).** GEOGEBRA, INC., (U.S. CLS. 21, 23, 26, 36 AND 38). SN 76-706,220. PUB. 6-7-2011. FILED 2-1-2011.
 4,014,240. **NITRIX (STANDARD CHARACTER).** MAGID GLOVE AND SAFETY MANUFACTURING CO., L.L.C., (U.S. CLS. 21, 23, 26, 36 AND 38). SN 76-706,255. PUB. 6-7-2011. FILED 1-31-2011.
 4,014,245. **IMPACT (STANDARD CHARACTER).** STEELCASE INC., MULTIPLE CLASS, (INT. CLS. 9 AND 20), (U.S. CLS. 2, 13, 21, 22, 23, 25, 26, 32, 36, 38 AND 50). SN 77-010,583. PUB. 6-7-2011. FILED 9-29-2006.
 4,014,247. **GEAMELEON (STANDARD CHARACTER).** AEG GESELLSCHAFT FUER MODERNE INFORMATIONS-SYSTEME MBH, MULTIPLE CLASS, (INT. CLS. 9, 11 AND 37), (U.S. CLS. 13, 21, 23, 26, 31, 34, 36, 38, 100, 103 AND 106). SN 77-075,019. PUB. 4-29-2008. FILED 1-3-2007.
 4,014,250. **INVISIBLE AND DESIGN.** RICHES, MARK, MULTIPLE CLASS, (INT. CLS. 9, 10 AND 42), (U.S. CLS. 21, 23, 26, 36, 38, 39, 44, 100 AND 101). SN 77-203,905. PUB. 2-22-2011. FILED 6-12-2007.
 4,014,252. **SOLAR ELECTRIC AND DESIGN.** DOUMITH, DAVID, MULTIPLE CLASS, (INT. CLS. 9 AND 11), (U.S. CLS. 13, 21, 23, 26, 31, 34, 36 AND 38). SN 77-266,261. PUB. 6-7-2011. FILED 8-28-2007.
 4,014,253. **LITTLE MISS TROUBLE (STANDARD CHARACTER).** THOIP, MULTIPLE CLASS, (INT. CLS. 9, 16, 25, 28 AND 41), (U.S. CLS. 2, 5, 21, 22, 23, 26, 29, 36, 37, 38, 39, 50, 100, 101 AND 107). SN 77-311,519. PUB. 3-1-2011. FILED 10-23-2007.
 4,014,254. **LITTLE MISS TROUBLE AND DESIGN.** THOIP, MULTIPLE CLASS, (INT. CLS. 9, 16, 25, 28 AND 41), (U.S. CLS. 2, 5, 21, 22, 23, 26, 29, 36, 37, 38, 39, 50, 100, 101 AND 107). SN 77-312,521. PUB. 3-1-2011. FILED 10-24-2007.
 4,014,271. **KYORAKU AND DESIGN.** KYORAKU INDUSTRIAL CO., LTD., MULTIPLE CLASS, (INT. CLS. 9, 28, 29, 30, 31 AND 41), (U.S. CLS. 1, 21, 22, 23, 26, 36, 38, 46, 50, 100, 101 AND 107). SN 77-585,415. PUB. 6-7-2011. FILED 10-3-2008.
 4,014,284. **T AND DESIGN.** TAGLE INFORMATION TECHNOLOGY INC., MULTIPLE CLASS, (INT. CLS. 9 AND 42), (U.S. CLS. 21, 23, 26, 36, 38, 100 AND 101). SN 77-638,324. PUB. 6-7-2011. FILED 12-22-2008.
 4,014,286. **UNITEK (STYLIZED).** POWER TECHNOLOGY, INC., (U.S. CLS. 21, 23, 26, 36 AND 38). SN 77-651,086. PUB. 6-7-2011. FILED 1-16-2009.
 4,014,288. **FUSION (STANDARD CHARACTER).** ZAXCOM, INC., (U.S. CLS. 21, 23, 26, 36 AND 38). SN 77-663,889. PUB. 6-7-2011. FILED 2-5-2009.
 4,014,290. **EX LIBRIS MOSAIC AND DESIGN.** EX LIBRIS LTD., MULTIPLE CLASS, (INT. CLS. 9 AND 42), (U.S. CLS. 21, 23, 26, 36, 38, 100 AND 101). SN 77-665,987. PUB. 6-7-2011. FILED 2-9-2009.
 4,014,294. **IDED (STANDARD CHARACTER).** JENTEK SENSORS, INC., (U.S. CLS. 21, 23, 26, 36 AND 38). SN 77-673,859. PUB. 6-23-2009. FILED 2-19-2009.
 4,014,311 (*See Class 6 for this trademark.*)
 4,014,312. **NAPICOS AND DESIGN.** NIHON DEMP KOGYO CO., LTD., MULTIPLE CLASS, (INT. CLS. 9 AND 10), (U.S. CLS. 21, 23, 26, 36, 38, 39 AND 44). SN 77-752,364. PUB. 6-7-2011. FILED 6-4-2009.
 4,014,314 (*See Class 6 for this trademark.*)
 4,014,315. **THINKING ALOUD MAKING SENSE OF LITERACY AND DESIGN.** UNIVERSITY OF NORTHERN IOWA, MULTIPLE CLASS, (INT. CLS. 9 AND 41), (U.S. CLS. 21, 23, 26, 36, 38, 100, 101 AND 107). SN 77-760,965. PUB. 3-1-2011. FILED 6-16-2009.
 4,014,316. **PROMETHEAN ACTIVPACKS (STANDARD CHARACTER).** PROMETHEAN LIMITED, MULTIPLE CLASS, (INT. CLS. 9, 16, 38, 41 AND 42), (U.S. CLS. 2, 5, 21, 22, 23, 26, 29, 36, 37, 38, 50, 100, 101, 104 AND 107). SN 77-763,161. PUB. 6-7-2011. FILED 6-18-2009.
 4,014,317. **PROMETHEAN ACTIVLESSONS (STANDARD CHARACTER).** PROMETHEAN LIMITED, MULTIPLE CLASS, (INT. CLS. 9, 16, 38, 41 AND 42), (U.S. CLS. 2, 5, 21, 22, 23, 26, 29, 36, 37, 38, 50, 100, 101, 104 AND 107). SN 77-763,167. PUB. 6-7-2011. FILED 6-18-2009.
 4,014,324. **READING WRITING SPEAKING LISTENING VIEWING AND DESIGN.** UNIVERSITY OF NORTHERN IOWA, (U.S. CLS. 21, 23, 26, 36 AND 38). SN 77-775,709. PUB. 6-7-2011. FILED 7-7-2009.
 4,014,326. **SIGENGINE (STANDARD CHARACTER).** SIGNAL STUDIOS, LLC, (U.S. CLS. 21, 23, 26, 36 AND 38). SN 77-794,342. PUB. 6-7-2011. FILED 7-31-2009.
 4,014,327 (*See Class 3 for this trademark.*)
 4,014,335. **ECLINICALWORKS P2P (STANDARD CHARACTER).** ECLINICALWORKS, LLC, (U.S. CLS. 21, 23, 26, 36 AND 38). SN 77-824,319. PUB. 6-7-2011. FILED 9-10-2009.
 4,014,336. **SOCIETY OF CRITICAL CARE MEDICINE THE INTENSIVE CARE PROFESSIONALS AND DESIGN.** SOCIETY OF CRITICAL CARE MEDICINE, MULTIPLE CLASS, (INT. CLS. 9, 16, 21, 25, 35, 38, 41 AND 44), (U.S. CLS. 2, 5, 13, 21, 22, 23, 26, 29, 30, 33, 36, 37, 38, 39, 40, 50, 100, 101, 102, 104 AND 107). SN 77-824,743. PUB. 6-7-2011. FILED 9-11-2009.
 4,014,337 (*See Class 6 for this trademark.*)
 4,014,338. **JAVA POWERED AND DESIGN.** ORACLE AMERICA, INC., (U.S. CLS. 21, 23, 26, 36 AND 38). SN 77-828,113. PUB. 6-7-2011. FILED 9-16-2009.
 4,014,344. **CATS (STANDARD CHARACTER).** GORDON MANAGEMENT PARTNERS, LLC, (U.S. CLS. 21, 23, 26, 36 AND 38). SN 77-849,757. PUB. 12-7-2010. FILED 10-15-2009.
 4,014,347. **AIRSOL (STANDARD CHARACTER).** LS CABLE LTD., (U.S. CLS. 21, 23, 26, 36 AND 38). SN 77-855,704. PUB. 6-7-2011. FILED 10-23-2009.
 4,014,378. **VENZA GROUP (STANDARD CHARACTER).** VENZA LEARNING SOLUTIONS, INC., MULTIPLE CLASS, (INT. CLS. 9 AND 42), (U.S. CLS. 21, 23, 26, 36, 38, 100 AND 101). SN 77-903,082. PUB. 6-7-2011. FILED 12-30-2009.
 4,014,379. **V VENZA GROUP AND DESIGN.** VENZA LEARNING SOLUTIONS, INC., MULTIPLE CLASS, (INT. CLS. 9 AND 42), (U.S. CLS. 21, 23, 26, 36, 38, 100 AND 101). SN 77-903,245. PUB. 6-7-2011. FILED 12-30-2009.
 4,014,380. **VENZA SHERPA (STANDARD CHARACTER).** VENZA LEARNING SOLUTIONS, INC., MULTIPLE CLASS, (INT. CLS. 9 AND 42), (U.S. CLS. 21, 23, 26, 36, 38, 100 AND 101). SN 77-903,507. PUB. 6-7-2011. FILED 12-31-2009.
 4,014,382. **FAST LANE AND DESIGN.** MASSACHUSETTS DEPARTMENT OF TRANSPORTATION, MULTIPLE CLASS, (INT. CLS. 9 AND 36), (U.S. CLS. 21, 23, 26, 36, 38, 100, 101 AND 102). SN 77-905,365. PUB. 6-7-2011. FILED 1-5-2010.
 4,014,383. **DCAST AND DESIGN.** DCAST, LLC, MULTIPLE CLASS, (INT. CLS. 9, 38 AND 42), (U.S. CLS. 21, 23, 26, 36, 38, 100, 101 AND 104). SN 77-907,080. PUB. 6-7-2011. FILED 1-7-2010.
 4,014,385. **KINETIK (STANDARD CHARACTER).** OD DISTRIBUTORS LLC, (U.S. CLS. 21, 23, 26, 36 AND 38). SN 77-909,172. PUB. 6-7-2011. FILED 1-11-2010.
 4,014,391. **WETA (STANDARD CHARACTER).** PJR HOLDINGS LIMITED, MULTIPLE CLASS, (INT. CLS. 9, 14, 20 AND 42), (U.S. CLS. 2, 13, 21, 22, 23, 25, 26, 27, 28, 32, 36, 38,

- 50, 100 AND 101). SN 77-918,933. PUB. 6-7-2011. FILED 1-24-2010.
- 4,014,392. @ AND DESIGN. LG ELECTRONICS INC., (U.S. CLS. 21, 23, 26, 36 AND 38). SN 77-919,241. PUB. 6-7-2011. FILED 1-25-2010.
- 4,014,393. AIRFREE (STANDARD CHARACTER). FISHMAN CORPORATION, (U.S. CLS. 21, 23, 26, 36 AND 38). SN 77-919,389. PUB. 6-7-2011. FILED 1-25-2010.
- 4,014,395. SCORIO (STANDARD CHARACTER). FUN COMMUNICATIONS GMBH, MULTIPLE CLASS, (INT. CLS. 9, 35, 38, 41, 42 AND 45), (U.S. CLS. 21, 23, 26, 36, 38, 100, 101, 102, 104 AND 107). SN 77-920,543. PUB. 6-7-2011. FILED 1-26-2010.
- 4,014,399. I-MODULE (STANDARD CHARACTER). REDXFENSE, LLC, (U.S. CLS. 21, 23, 26, 36 AND 38). SN 77-927,166. PUB. 6-7-2011. FILED 2-3-2010.
- 4,014,409. FRS (STANDARD CHARACTER). IMAGE-I-NATION TECHNOLOGIES, INC., DBA IMAGINATION TECHNOLOGIES, (U.S. CLS. 21, 23, 26, 36 AND 38). SN 77-946,720. PUB. 6-7-2011. FILED 2-28-2010.
- 4,014,411. MURGITROYD IP PORTAL (STANDARD CHARACTER). MURGITROYD & COMPANY, MULTIPLE CLASS, (INT. CLS. 9, 16, 35, 41, 42 AND 45), (U.S. CLS. 2, 5, 21, 22, 23, 26, 29, 36, 37, 38, 50, 100, 101, 102 AND 107). SN 77-950,289. PUB. 6-7-2011. FILED 3-4-2010.
- 4,014,421. DYNAMICS TMS (STANDARD CHARACTER). NEXT GENERATION LOGISTICS, INC., (U.S. CLS. 21, 23, 26, 36 AND 38). SN 77-960,872. PUB. 6-7-2011. FILED 3-17-2010.
- 4,014,425. MEGASEND (STYLIZED). SEB S.A., MULTIPLE CLASS, (INT. CLS. 9, 38 AND 42), (U.S. CLS. 21, 23, 26, 36, 38, 100, 101 AND 104). SN 77-969,681. PUB. 3-15-2011. FILED 3-26-2010.
- 4,014,426. H&FJ (STYLIZED). THE HOEFLER TYPE FOUNDRY, INC., DBA HOEFLER & FRERE-JONES, MULTIPLE CLASS, (INT. CLS. 9 AND 42), (U.S. CLS. 21, 23, 26, 36, 38, 100 AND 101). SN 77-981,527. PUB. 11-24-2009. FILED 1-23-2009.
- 4,014,429 (See Class 3 for this trademark).
- 4,014,432 (See Class 3 for this trademark).
- 4,014,444. CIMA STRATEGIC SCORECARD (STYLIZED). THE CHARTERED INSTITUTE OF MANAGEMENT ACCOUNTANTS, MULTIPLE CLASS, (INT. CLS. 9, 16, 35 AND 41), (U.S. CLS. 2, 5, 21, 22, 23, 26, 29, 36, 37, 38, 50, 100, 101, 102 AND 107). SN 79-013,582. PUB. 3-23-2010. FILED 5-24-2005.
- 4,014,445 (See Class 3 for this trademark).
- 4,014,446. THERMIK (STANDARD CHARACTER). THERMIK GERÄTEBAU GMBH, (U.S. CLS. 21, 23, 26, 36 AND 38). SN 79-029,019. PUB. 6-7-2011. FILED 8-22-2006.
- 4,014,447. OS (STYLIZED). OSRAM GESELLSCHAFT MIT BESCHRÄNKTER HAFTUNG, MULTIPLE CLASS, (INT. CLS. 9 AND 11), (U.S. CLS. 13, 21, 23, 26, 31, 34, 36 AND 38). SN 79-036,152. PUB. 6-7-2011. FILED 2-8-2007.
- 4,014,448. SUPERVISION AND DESIGN. IPEK SPEZIAL-TV GESMBH & CO. KG, (U.S. CLS. 21, 23, 26, 36 AND 38). SN 79-037,661. PUB. 6-7-2011. FILED 3-26-2007.
- 4,014,452 (See Class 6 for this trademark).
- 4,014,453. MAGNEAT (STANDARD CHARACTER). ROYAL EHF, MULTIPLE CLASS, (INT. CLS. 9 AND 38), (U.S. CLS. 21, 23, 26, 36, 38, 100, 101 AND 104). SN 79-067,149. PUB. 6-7-2011. FILED 10-27-2008.
- 4,014,458. HELSINN NEWSWIRE AND DESIGN. HELSINN HEALTHCARE SA, MULTIPLE CLASS, (INT. CLS. 9, 16 AND 41), (U.S. CLS. 2, 5, 21, 22, 23, 26, 29, 36, 37, 38, 50, 100, 101 AND 107). SN 79-073,620. PUB. 6-7-2011. FILED 5-28-2009.
- 4,014,460 (See Class 1 for this trademark).
- 4,014,464 (See Class 3 for this trademark).
- 4,014,465. SENETAS (STANDARD CHARACTER). SENETAS CORPORATION LIMITED, MULTIPLE CLASS, (INT. CLS. 9 AND 42), (U.S. CLS. 21, 23, 26, 36, 38, 100 AND 101). SN 79-077,130. PUB. 6-7-2011. FILED 11-24-2009.
- 4,014,473. GOGEAR ARIA (STANDARD CHARACTER). KONINKLIJKE PHILIPS ELECTRONICS N.V., (U.S. CLS. 21, 23, 26, 36 AND 38). SN 79-078,858. PUB. 6-7-2011. FILED 1-18-2010.
- 4,014,474. LICOS TRUCKTEC GMBH AND DESIGN. LICOS TRUCKTEC GMBH, MULTIPLE CLASS, (INT. CLS. 9 AND 12), (U.S. CLS. 19, 21, 23, 26, 31, 35, 36, 38 AND 44). SN 79-078,870. PUB. 6-7-2011. FILED 11-25-2009.
- 4,014,479. NIPPONOPHONE (STANDARD CHARACTER). COLUMBIA MUSIC ENTERTAINMENT, INC., MULTIPLE CLASS, (INT. CLS. 9 AND 41), (U.S. CLS. 21, 23, 26, 36, 38, 100, 101 AND 107). SN 79-079,159. PUB. 6-7-2011. FILED 9-16-2009.
- 4,014,482 (See Class 7 for this trademark).
- 4,014,484. RIVERSEAL (STANDARD CHARACTER). RIVERTEX UK LIMITED, MULTIPLE CLASS, (INT. CLS. 9, 17 AND 24), (U.S. CLS. 1, 5, 12, 13, 21, 23, 26, 35, 36, 38, 42 AND 50). SN 79-080,207. PUB. 6-7-2011. FILED 11-25-2009.
- 4,014,486 (See Class 4 for this trademark).
- 4,014,488 (See Class 7 for this trademark).
- 4,014,490. LASERCHASER (STYLIZED). DAVID CHAMBERLAIN, MULTIPLE CLASS, (INT. CLS. 9 AND 21), (U.S. CLS. 2, 13, 21, 23, 26, 29, 30, 33, 36, 38, 40 AND 50). SN 79-082,041. PUB. 6-7-2011. FILED 12-10-2009.
- 4,014,494. FONTSELF (STANDARD CHARACTER). FONTSELF SA, MULTIPLE CLASS, (INT. CLS. 9, 35, 41 AND 42), (U.S. CLS. 21, 23, 26, 36, 38, 100, 101, 102 AND 107). SN 79-082,442. PUB. 6-7-2011. FILED 4-23-2010.
- 4,014,495. THE BROW (STANDARD CHARACTER). HANS A. VAN AANHOLT, MULTIPLE CLASS, (INT. CLS. 9 AND 25), (U.S. CLS. 21, 22, 23, 26, 36, 38 AND 39). SN 79-082,621. PUB. 6-7-2011. FILED 4-29-2010.
- 4,014,497 (See Class 3 for this trademark).
- 4,014,498. HYBERNITE (STANDARD CHARACTER). PLASTIFLEX GROUP, NAAMLOZE VENNOOTSCHAP, MULTIPLE CLASS, (INT. CLS. 9, 10 AND 17), (U.S. CLS. 1, 5, 12, 13, 21, 23, 26, 35, 36, 38, 39, 44 AND 50). SN 79-083,248. PUB. 6-7-2011. FILED 3-24-2010.
- 4,014,502. COLORFLY (STYLIZED). SHENZHEN SEETHRU TELECOMMUNICATION COMPANY LTD., (U.S. CLS. 21, 23, 26, 36 AND 38). SN 79-083,936. PUB. 6-7-2011. FILED 5-26-2010.
- 4,014,503. KUNESTO (STANDARD CHARACTER). KUNESTO DIENSTLEISTUNGSGESELLSCHAFT MBH, MULTIPLE CLASS, (INT. CLS. 9, 16, 35, 38, 41, 42, 43 AND 45), (U.S. CLS. 2, 5, 21, 22, 23, 26, 29, 36, 37, 38, 50, 100, 101, 102, 104 AND 107). SN 79-084,121. PUB. 6-7-2011. FILED 3-3-2010.
- 4,014,506 (See Class 1 for this trademark).
- 4,014,507. RADIOMATIX (STANDARD CHARACTER). RADIOMATIX, NAAMLOZE VENNOOTSCHAP, MULTIPLE CLASS, (INT. CLS. 9, 42 AND 44), (U.S. CLS. 21, 23, 26, 36, 38, 100 AND 101). SN 79-084,482. PUB. 6-7-2011. FILED 6-10-2010.
- 4,014,509. NCAT (STANDARD CHARACTER). THE CROWN IN RIGHT OF THE COMMONWEALTH, MULTIPLE CLASS, (INT. CLS. 9, 35, 42 AND 44), (U.S. CLS. 21, 23, 26, 36, 38, 100, 101 AND 102). SN 79-084,574. PUB. 6-7-2011. FILED 6-3-2010.
- 4,014,510. HEADSPACE (STANDARD CHARACTER). HEADSPACE MEDITATION LIMITED, MULTIPLE CLASS, (INT. CLS. 9, 16, 20, 25, 38, 41 AND 44), (U.S. CLS. 2, 5, 13, 21, 22, 23, 25, 26, 29, 32, 36, 37, 38, 39, 50, 100, 101, 104 AND 107). SN 79-084,609. PUB. 6-7-2011. FILED 6-11-2010.
- 4,014,515. MOVE)LOG (STANDARD CHARACTER). AGS ANDREAS GRUBER SOFTWARE GMBH, MULTIPLE CLASS, (INT. CLS. 9, 35 AND 42), (U.S. CLS. 21, 23, 26, 36, 38, 100, 101 AND 102). SN 79-085,084. PUB. 6-7-2011. FILED 12-16-2009.
- 4,014,516 (See Class 7 for this trademark).
- 4,014,521. ITELLIGENCE (STYLIZED). ITELLIGENCE AG, MULTIPLE CLASS, (INT. CLS. 9, 35 AND 42), (U.S. CLS. 21, 23, 26, 36, 38, 100, 101 AND 102). SN 79-085,259. PUB. 6-7-2011. FILED 6-14-2010.
- 4,014,522. MY DITTO AND DESIGN. DANE-ELEC MEMORY, (U.S. CLS. 21, 23, 26, 36 AND 38). SN 79-085,470. PUB. 6-7-2011. FILED 6-25-2010.
- 4,014,529. ARTDECO AND DESIGN. ARTDECO COSMETIC GMBH, (U.S. CLS. 21, 23, 26, 36 AND 38). SN 79-085,613. PUB. 6-7-2011. FILED 7-13-2010.
- 4,014,530. SMIE (STANDARD CHARACTER). SIEMENS IT SOLUTIONS AND SERVICES GMBH, MULTIPLE CLASS, (INT. CLS. 9, 35, 42 AND 45), (U.S. CLS. 21, 23, 26, 36, 38, 100, 101 AND 102). SN 79-085,705. PUB. 6-7-2011. FILED 3-15-

- 2010.
- 4,014,543. **MD MAKRO DETECTOR AND DESIGN. MAKRO GRUP ELEKTRONIK MÜHENDISLIK SANAYI VE TICARET ANONIM SİRKETİ**, (U.S. CLS. 21, 23, 26, 36 AND 38). SN 79-086,571. PUB. 6-7-2011. FILED 6-23-2010.
- 4,014,547 (*See Class 7 for this trademark*).
- 4,014,550. **M AND DESIGN. PERSISTENT CACHE PTY LTD AS TRUSTEE FOR PERSISTENT CACHE UNIT TRUST**, (U.S. CLS. 21, 23, 26, 36 AND 38). SN 79-086,751. PUB. 6-7-2011. FILED 7-28-2010.
- 4,014,554. **TEAM E EVOLUTION TEAM TRANSPARENT-MUSIC-TEACHER AND DESIGN. BRUNO SATTLECKER**, (U.S. CLS. 21, 23, 26, 36 AND 38). SN 79-087,001. PUB. 6-7-2011. FILED 8-4-2010.
- 4,014,559. **MC4QUICK (STANDARD CHARACTER). MULTIHOLDING AG**, (U.S. CLS. 21, 23, 26, 36 AND 38). SN 79-087,241. PUB. 6-7-2011. FILED 4-12-2010.
- 4,014,573. **EFFECTOR (STYLIZED). CRADLE LIMITED LIABILITY COMPANY**, (U.S. CLS. 21, 23, 26, 36 AND 38). SN 79-087,910. PUB. 6-7-2011. FILED 6-4-2010.
- 4,014,577 (*See Class 7 for this trademark*).
- 4,014,580. **CHINESE QUEEN AND DESIGN. UNIVERSAL ENTERTAINMENT CORPORATION, MULTIPLE CLASS**, (INT. CLS. 9 AND 28), (U.S. CLS. 21, 22, 23, 26, 36, 38 AND 50). SN 79-088,675. PUB. 6-7-2011. FILED 8-27-2010.
- 4,014,582. **BRIGHTCAST (STYLIZED). BEIJING BRIGHTCAST CO., LTD., MULTIPLE CLASS**, (INT. CLS. 9 AND 11), (U.S. CLS. 13, 21, 23, 26, 31, 34, 36 AND 38). SN 79-088,770. PUB. 6-7-2011. FILED 6-30-2010.
- 4,014,583. **EQUIAIRBAG AND DESIGN. COLOMBO FABIO GIOVANNI FEDELE, AND COLOMBO ANTONIO PRIMO, MULTIPLE CLASS**, (INT. CLS. 9, 25 AND 28), (U.S. CLS. 21, 22, 23, 26, 36, 38, 39 AND 50). SN 79-088,867. PUB. 6-7-2011. FILED 7-22-2010.
- 4,014,593. **VV AND DESIGN. MARKER VÖKL (INTERNATIONAL) GMBH, MULTIPLE CLASS**, (INT. CLS. 9, 18, 25, 28 AND 41), (U.S. CLS. 1, 2, 3, 21, 22, 23, 26, 36, 38, 39, 41, 50, 100, 101 AND 107). SN 79-089,593. PUB. 6-7-2011. FILED 8-24-2010.
- 4,014,599. **PRISENCOLINENSINAINCIUSOL (STANDARD CHARACTER). CELENTANO ADRIANO, MULTIPLE CLASS**, (INT. CLS. 9, 14, 16, 25, 32 AND 41), (U.S. CLS. 2, 5, 21, 22, 23, 26, 27, 28, 29, 36, 37, 38, 39, 45, 46, 48, 50, 100, 101 AND 107). SN 79-089,976. PUB. 6-7-2011. FILED 7-9-2010.
- 4,014,603. **GEOLICA (STANDARD CHARACTER). GEO MEDICAL CO., LTD.**, (U.S. CLS. 21, 23, 26, 36 AND 38). SN 79-090,303. PUB. 6-7-2011. FILED 8-31-2010.
- 4,014,614. **PRIMERGY DUPLEXDATAMANAGER (STANDARD CHARACTER). FUJITSU TECHNOLOGY SOLUTIONS INTELLECTUAL PROPERTY GMBH**, (U.S. CLS. 21, 23, 26, 36 AND 38). SN 79-090,788. PUB. 6-7-2011. FILED 10-18-2010.
- 4,014,617. **ATC AND DESIGN. DONGFENG-FUJI-THOMSON THERMOSTAT CO., LTD.**, (U.S. CLS. 21, 23, 26, 36 AND 38). SN 79-091,012. PUB. 6-7-2011. FILED 11-25-2010.
- 4,014,628. **THE PORT TECHNOLOGY AND DESIGN. INVENTIO AG, MULTIPLE CLASS**, (INT. CLS. 9, 35, 38 AND 45), (U.S. CLS. 21, 23, 26, 36, 38, 100, 101, 102 AND 104). SN 79-091,838. PUB. 6-7-2011. FILED 10-21-2010.
- 4,014,629 (*See Class 7 for this trademark*).
- 4,014,632. **COREMINE (STANDARD CHARACTER). PUBGENE AS, MULTIPLE CLASS**, (INT. CLS. 9 AND 42), (U.S. CLS. 21, 23, 26, 36, 38, 100 AND 101). SN 79-092,035. PUB. 6-7-2011. FILED 8-26-2010.
- 4,014,643. **FATBOOTH (STANDARD CHARACTER). PIVI & CO**, (U.S. CLS. 21, 23, 26, 36 AND 38). SN 79-093,347. PUB. 6-7-2011. FILED 1-18-2011.
- 4,014,650. **BINARY DOMAIN (STANDARD CHARACTER). KABUSHIKI KAISHA SEGA, D/B/A SEGA CORPORATION**, (U.S. CLS. 21, 23, 26, 36 AND 38). SN 79-094,902. PUB. 6-7-2011. FILED 2-2-2011.
- 4,014,664. **ZORG AND DESIGN. PRIVATEWAVE ITALIA S.P.A., MULTIPLE CLASS**, (INT. CLS. 9, 38 AND 42), (U.S. CLS. 21, 23, 26, 36, 38, 100, 101 AND 104). SN 79-095,770. PUB. 6-7-2011. FILED 12-10-2010.
- 4,014,666. **MINDNOTE (STANDARD CHARACTER). EST-SOFT CORP., MULTIPLE CLASS**, (INT. CLS. 9, 35 AND 42), (U.S. CLS. 21, 23, 26, 36, 38, 100, 101 AND 102). SN 79-095,804. PUB. 6-7-2011. FILED 1-24-2011.
- 4,014,668. **MINDMAPLE (STANDARD CHARACTER). EST-SOFT CORP., MULTIPLE CLASS**, (INT. CLS. 9, 35 AND 42), (U.S. CLS. 21, 23, 26, 36, 38, 100, 101 AND 102). SN 79-095,879. PUB. 6-7-2011. FILED 2-25-2011.
- 4,014,673. **SMARTY SHORTZ AND DESIGN. SMARTY-SHORTZ LLC**, (U.S. CLS. 21, 23, 26, 36 AND 38). SN 85-010,318. PUB. 6-7-2011. FILED 4-9-2010.
- 4,014,675. **TREE SOUND STUDIOS (STANDARD CHARACTER). TREE SOUND STUDIOS, INC.**, (U.S. CLS. 21, 23, 26, 36 AND 38). SN 85-012,670. PUB. 6-7-2011. FILED 4-13-2010.
- 4,014,677. **SWEDISH HOUSE MAFIA AND DESIGN. SHM HOLDINGS, LTD., MULTIPLE CLASS**, (INT. CLS. 9, 35 AND 41), (U.S. CLS. 21, 23, 26, 36, 38, 100, 101, 102 AND 107). SN 85-017,358. PUB. 6-7-2011. FILED 4-19-2010.
- 4,014,704. **LIDDLES AND DESIGN. PUSH BUTTON LABS**, (U.S. CLS. 21, 23, 26, 36 AND 38). SN 85-038,657. PUB. 3-1-2011. FILED 5-14-2010.
- 4,014,710. **INREV (STANDARD CHARACTER). EUROPEAN REAL ESTATE ASSOCIATION OF INVESTORS IN NON LISTED REAL ESTATE VEHICLES (INREV), MULTIPLE CLASS**, (INT. CLS. 9, 16, 35, 36 AND 41), (U.S. CLS. 2, 5, 21, 22, 23, 26, 29, 36, 37, 38, 50, 100, 101, 102 AND 107). SN 85-041,722. PUB. 6-7-2011. FILED 5-18-2010.
- 4,014,711. **INREV (STYLIZED). EUROPEAN ASSOCIATION OF INVESTORS IN NON LISTED REAL ESTATE VEHICLES (INREV), MULTIPLE CLASS**, (INT. CLS. 9, 16, 35, 36 AND 41), (U.S. CLS. 2, 5, 21, 22, 23, 26, 29, 36, 37, 38, 50, 100, 101, 102 AND 107). SN 85-041,734. PUB. 6-7-2011. FILED 5-18-2010.
- 4,014,712. **CARVED RECORDS (STANDARD CHARACTER). CARVED RECORDS, LLC**, (U.S. CLS. 21, 23, 26, 36 AND 38). SN 85-042,677. PUB. 6-7-2011. FILED 5-19-2010.
- 4,014,721. **HANCOM (STANDARD CHARACTER). HAAN-SOFT INC., MULTIPLE CLASS**, (INT. CLS. 9 AND 42), (U.S. CLS. 21, 23, 26, 36, 38, 100 AND 101). SN 85-048,374. PUB. 6-7-2011. FILED 5-26-2010.
- 4,014,729. **POLARIS GLOBAL AND DESIGN. POLARIS GLOBAL MARKETING, LLC, MULTIPLE CLASS**, (INT. CLS. 9 AND 41), (U.S. CLS. 21, 23, 26, 36, 38, 100, 101 AND 107). SN 85-051,285. PUB. 6-7-2011. FILED 5-31-2010.
- 4,014,739. **CITYMINT TAP. ORDER. EAT. AND DESIGN. CITYMINT, INC.**, (U.S. CLS. 21, 23, 26, 36 AND 38). SN 85-054,604. PUB. 6-7-2011. FILED 6-4-2010.
- 4,014,740. **U.S. PAYMENTS (STANDARD CHARACTER). U.S. PAYMENTS, LLC, MULTIPLE CLASS**, (INT. CLS. 9, 35 AND 36), (U.S. CLS. 21, 23, 26, 36, 38, 100, 101 AND 102). SN 85-055,231. PUB. 6-7-2011. FILED 6-4-2010.
- 4,014,749. **CONTOURGT (STANDARD CHARACTER). VEECO METROLOGY INC.**, (U.S. CLS. 21, 23, 26, 36 AND 38). SN 85-057,707. PUB. 6-7-2011. FILED 6-8-2010.
- 4,014,750. **PLAY-A-DENT (STANDARD CHARACTER). IDEA INTERNATIONAL, INC.**, (U.S. CLS. 21, 23, 26, 36 AND 38). SN 85-058,894. PUB. 6-7-2011. FILED 6-9-2010.
- 4,014,759 (*See Class 2 for this trademark*).
- 4,014,764. **SIPITY (STANDARD CHARACTER). TELENNAV, INC., MULTIPLE CLASS**, (INT. CLS. 9 AND 35), (U.S. CLS. 21, 23, 26, 36, 38, 100, 101 AND 102). SN 85-064,165. PUB. 6-7-2011. FILED 6-16-2010.
- 4,014,766. **SOFTTRANS (STANDARD CHARACTER). ELAVON, INC.**, (U.S. CLS. 21, 23, 26, 36 AND 38). SN 85-064,304. PUB. 6-7-2011. FILED 6-16-2010.
- 4,014,777. **READING EGGSPRESS (STANDARD CHARACTER). BLAKE PUBLISHING PTY LTD, MULTIPLE CLASS**, (INT. CLS. 9, 16 AND 41), (U.S. CLS. 2, 5, 21, 22, 23, 26, 29, 36, 37, 38, 50, 100, 101 AND 107). SN 85-065,991. PUB. 6-7-2011. FILED 6-18-2010.
- 4,014,778. **READING EGGSPRESS AND DESIGN. BLAKE PUBLISHING PTY LTD, MULTIPLE CLASS**, (INT. CLS. 9, 16 AND 41), (U.S. CLS. 2, 5, 21, 22, 23, 26, 29, 36, 37, 38, 50, 100, 101 AND 107). SN 85-065,999. PUB. 6-7-2011. FILED 6-18-2010.
- 4,014,788. **STORYRUNNERS (STANDARD CHARACTER). CAMPUS CRUSADE FOR CHRIST, INC., AKA CAMPUS CRUSADE FOR CHRIST INTERNATIONAL; CCCI, MULTIPLE CLASS**, (INT. CLS. 9, 16, 35, 38, 41 AND 45), (U.S. CLS. 2, 5, 21, 22, 23, 26, 29, 36, 37, 38, 50, 100, 101, 102, 104 AND 107). SN 85-068,061. PUB. 6-7-2011. FILED 6-21-2010.

- 4,014,793. **DAUGHTRY (STANDARD CHARACTER)**. CDD HOLDING, LLC, (U.S. CLS. 21, 23, 26, 36 AND 38). SN 85-070,416. PUB. 6-7-2011. FILED 6-24-2010.
- 4,014,796. **HANDS ON (STANDARD CHARACTER)**. HANDS ON INTERNATIONAL, LLC, MULTIPLE CLASS, (INT. CLS. 9 AND 21), (U.S. CLS. 2, 13, 21, 23, 26, 29, 30, 33, 36, 38, 40 AND 50). SN 85-070,836. PUB. 6-7-2011. FILED 6-24-2010.
- 4,014,816. **PCI FILTERS (STANDARD CHARACTER)**. ATX NETWORKS CORP., (U.S. CLS. 21, 23, 26, 36 AND 38). SN 85-074,928. PUB. 6-7-2011. FILED 6-30-2010.
- 4,014,823. **CONNECT+ (STANDARD CHARACTER)**. PITNEY BOWES INC., (U.S. CLS. 21, 23, 26, 36 AND 38). SN 85-075,738. PUB. 6-7-2011. FILED 7-1-2010.
- 4,014,826. **VALVE-SQUEAK (STANDARD CHARACTER)**. MISTRAS GROUP, INC., (U.S. CLS. 21, 23, 26, 36 AND 38). SN 85-076,124. PUB. 6-7-2011. FILED 7-1-2010.
- 4,014,828. **E O AND DESIGN**. STYLEMARK, INC., (U.S. CLS. 21, 23, 26, 36 AND 38). SN 85-076,158. PUB. 6-7-2011. FILED 7-1-2010.
- 4,014,830. **CLARIPHONIC (STANDARD CHARACTER)**. KUSH AUDIO, LLC, (U.S. CLS. 21, 23, 26, 36 AND 38). SN 85-076,676. PUB. 6-7-2011. FILED 7-2-2010.
- 4,014,831. **UBK (STANDARD CHARACTER)**. KUSH AUDIO, LLC, (U.S. CLS. 21, 23, 26, 36 AND 38). SN 85-076,681. PUB. 6-7-2011. FILED 7-2-2010.
- 4,014,832. **CLUSTERBOT (STANDARD CHARACTER)**. XOTAR CORPORATION, (U.S. CLS. 21, 23, 26, 36 AND 38). SN 85-077,566. PUB. 6-7-2011. FILED 7-2-2010.
- 4,014,833. **SLINGSHOT (STANDARD CHARACTER)**. ZEAL OPTICS, INC., (U.S. CLS. 21, 23, 26, 36 AND 38). SN 85-077,691. PUB. 6-7-2011. FILED 7-3-2010.
- 4,014,851. **EZTEST (STANDARD CHARACTER)**. SGM BIOTECH, INC., (U.S. CLS. 21, 23, 26, 36 AND 38). SN 85-081,562. PUB. 6-7-2011. FILED 7-9-2010.
- 4,014,885. **CULTURENIK (STANDARD CHARACTER)**. CULTURENIK PUBLISHING, INC., (U.S. CLS. 21, 23, 26, 36 AND 38). SN 85-088,889. PUB. 6-7-2011. FILED 7-20-2010.
- 4,014,888. **YES YOU DONE IT AND DESIGN**. REMONX, LLC, (U.S. CLS. 21, 23, 26, 36 AND 38). SN 85-090,010. PUB. 6-7-2011. FILED 7-21-2010.
- 4,014,899. **MAMBO ZOMBIES (STANDARD CHARACTER)**. DESORMEAUX, CHARLES, MULTIPLE CLASS, (INT. CLS. 9 AND 41), (U.S. CLS. 21, 23, 26, 36, 38, 100, 101 AND 107). SN 85-092,425. PUB. 6-7-2011. FILED 7-26-2010.
- 4,014,912 (*See Class 6 for this trademark*).
- 4,014,913. **DOCMAESTRO (STANDARD CHARACTER)**. ISPA, INC., (U.S. CLS. 21, 23, 26, 36 AND 38). SN 85-094,014. PUB. 6-7-2011. FILED 7-27-2010.
- 4,014,934. **KONRAD (STANDARD CHARACTER)**. KONRAD, JEFFREY, (U.S. CLS. 21, 23, 26, 36 AND 38). SN 85-098,559. PUB. 1-11-2011. FILED 8-2-2010.
- 4,014,966. **INTERWORKING LABS (STANDARD CHARACTER)**. INTERWORKING LABS, INC., (U.S. CLS. 21, 23, 26, 36 AND 38). SN 85-105,392. PUB. 6-7-2011. FILED 8-11-2010.
- 4,014,969. **SHOTPOINT TRACKER (STANDARD CHARACTER)**. DYNO NOBEL INC., (U.S. CLS. 21, 23, 26, 36 AND 38). SN 85-106,611. PUB. 6-7-2011. FILED 8-12-2010.
- 4,014,976. **POINTXCHANGE (STANDARD CHARACTER)**. WESTERN MONEY SYSTEMS, (U.S. CLS. 21, 23, 26, 36 AND 38). SN 85-110,247. PUB. 6-7-2011. FILED 8-18-2010.
- 4,014,994. **PRIME TIME HEROES (STANDARD CHARACTER)**. CARON, DIANNE L, MULTIPLE CLASS, (INT. CLS. 9 AND 41), (U.S. CLS. 21, 23, 26, 36, 38, 100, 101 AND 107). SN 85-119,257. PUB. 6-7-2011. FILED 8-30-2010.
- 4,014,999. **GENOCODE (STANDARD CHARACTER)**. LAVASOFT AB, (U.S. CLS. 21, 23, 26, 36 AND 38). SN 85-120,606. PUB. 5-10-2011. FILED 9-1-2010.
- 4,015,004. **NATIONAL HEALTH REVIEW (STANDARD CHARACTER)**. CALHOUN, CYNTHIA, MULTIPLE CLASS, (INT. CLS. 9 AND 16), (U.S. CLS. 2, 5, 21, 22, 23, 26, 29, 36, 37, 38 AND 50). SN 85-121,256. PUB. 6-7-2011. FILED 9-1-2010.
- 4,015,020. **ĀPSYLON (STANDARD CHARACTER)**. MADL, TIVADAR, DBA MSC RECORDS, (U.S. CLS. 21, 23, 26, 36 AND 38). SN 85-123,610. PUB. 6-7-2011. FILED 9-6-2010.
- 4,015,023. **QELLO (STANDARD CHARACTER)**. QELLO LLC, MULTIPLE CLASS, (INT. CLS. 9 AND 41), (U.S. CLS. 21, 23, 26, 36, 38, 100, 101 AND 107). SN 85-124,251. PUB. 6-7-2011. FILED 9-7-2010.
- 4,015,034. **MOVING TALES (STANDARD CHARACTER)**. MOVING TALES, INC., (U.S. CLS. 21, 23, 26, 36 AND 38). SN 85-127,078. PUB. 6-7-2011. FILED 9-10-2010.
- 4,015,045. **DECIBEL (STANDARD CHARACTER)**. NEW BRAND VISION LIMITED, MULTIPLE CLASS, (INT. CLS. 9, 16, 38, 41 AND 42), (U.S. CLS. 2, 5, 21, 22, 23, 26, 29, 36, 37, 38, 50, 100, 101, 104 AND 107). SN 85-130,518. PUB. 6-7-2011. FILED 9-15-2010.
- 4,015,052. **ZEUS VIRTUAL MACHINE (STANDARD CHARACTER)**. PARALLOCITY, INC, (U.S. CLS. 21, 23, 26, 36 AND 38). SN 85-133,876. PUB. 6-7-2011. FILED 9-20-2010.
- 4,015,065. **MAGIC CARPET (STANDARD CHARACTER)**. DAIMLER AG, MULTIPLE CLASS, (INT. CLS. 9, 12 AND 27), (U.S. CLS. 19, 20, 21, 23, 26, 31, 35, 36, 37, 38, 42, 44 AND 50). SN 85-137,664. PUB. 6-7-2011. FILED 9-24-2010.
- 4,015,071. **PUBLIC FUND SURVEY (STANDARD CHARACTER)**. NATIONAL ASSOCIATION OF STATE RETIREMENT ADMINISTRATORS, MULTIPLE CLASS, (INT. CLS. 9, 16 AND 41), (U.S. CLS. 2, 5, 21, 22, 23, 26, 29, 36, 37, 38, 50, 100, 101 AND 107). SN 85-139,741. PUB. 6-7-2011. FILED 9-28-2010.
- 4,015,074. **SMARTSHUTTER (STANDARD CHARACTER)**. SUTTER INSTRUMENT COMPANY, (U.S. CLS. 21, 23, 26, 36 AND 38). SN 85-140,209. PUB. 6-7-2011. FILED 9-28-2010.
- 4,015,081. **FLOCABULARY (STANDARD CHARACTER)**. FLOCABULARY, LLC, MULTIPLE CLASS, (INT. CLS. 9 AND 16), (U.S. CLS. 2, 5, 21, 22, 23, 26, 29, 36, 37, 38 AND 50). SN 85-142,429. PUB. 6-7-2011. FILED 9-30-2010.
- 4,015,109. **VISIONIX (STANDARD CHARACTER)**. VISIONIX LTD., (U.S. CLS. 21, 23, 26, 36 AND 38). SN 85-150,220. PUB. 6-7-2011. FILED 10-12-2010.
- 4,015,110. **MAKPOWER AND DESIGN**. MAKPOWER TECHNOLOGY, (U.S. CLS. 21, 23, 26, 36 AND 38). SN 85-150,393. PUB. 6-7-2011. FILED 10-12-2010.
- 4,015,114. **"X"-NUT (STANDARD CHARACTER)**. ELECTROMAGWAVE, INC., AKA E/M WAVE, INC., (U.S. CLS. 21, 23, 26, 36 AND 38). SN 85-152,493. PUB. 6-7-2011. FILED 10-14-2010.
- 4,015,115. **PUZZLER WORLD AND DESIGN**. PUZZLER MEDIA GROUP LIMITED, MULTIPLE CLASS, (INT. CLS. 9, 28 AND 41), (U.S. CLS. 21, 22, 23, 26, 36, 38, 50, 100, 101 AND 107). SN 85-153,007. PUB. 6-7-2011. FILED 10-14-2010.
- 4,015,116. **KOK AUDIO AND DESIGN**. NHIP SONG MUSIC, INC, (U.S. CLS. 21, 23, 26, 36 AND 38). SN 85-153,020. PUB. 6-7-2011. FILED 10-14-2010.
- 4,015,127. **SAT VSAT SYSTEMS AND DESIGN**. VSAT SYSTEMS, LLC, MULTIPLE CLASS, (INT. CLS. 9 AND 38), (U.S. CLS. 21, 23, 26, 36, 38, 100, 101 AND 104). SN 85-155,905. PUB. 6-7-2011. FILED 10-19-2010.
- 4,015,128. **LIGHTSNAKE (STANDARD CHARACTER)**. U.S. MUSIC CORPORATION, (U.S. CLS. 21, 23, 26, 36 AND 38). SN 85-156,691. PUB. 6-7-2011. FILED 10-20-2010.
- 4,015,135. **M CUBED TECHNOLOGIES INC. (STANDARD CHARACTER)**. M CUBED TECHNOLOGIES, INC., (U.S. CLS. 21, 23, 26, 36 AND 38). SN 85-158,119. PUB. 6-7-2011. FILED 10-21-2010.
- 4,015,151. **TEACHLOGIC AND DESIGN**. BVW HOLDINGS, LLC, (U.S. CLS. 21, 23, 26, 36 AND 38). SN 85-163,985. PUB. 6-7-2011. FILED 10-28-2010.
- 4,015,168. **TAYLOR SWIFT FEARLESS (STANDARD CHARACTER)**. SWIFT, TAYLOR, (U.S. CLS. 21, 23, 26, 36 AND 38). SN 85-168,861. PUB. 6-7-2011. FILED 11-4-2010.
- 4,015,178. **F AND DESIGN**. FLARECASTER, L.C., (U.S. CLS. 21, 23, 26, 36 AND 38). SN 85-171,380. PUB. 6-7-2011. FILED 11-8-2010.
- 4,015,190. **MATTHEW SHEPARD FOUNDATION EMBRACING DIVERSITY AND DESIGN**. THE MATTHEW SHEPARD FOUNDATION, MULTIPLE CLASS, (INT. CLS. 9, 16 AND 18), (U.S. CLS. 1, 2, 3, 5, 21, 22, 23, 26, 29, 36, 37, 38, 41 AND 50). SN 85-175,329. PUB. 6-7-2011. FILED 11-12-2010.
- 4,015,223. **STEINWAY & SONS (STANDARD CHARACTER)**. STEINWAY, INC., (U.S. CLS. 21, 23, 26, 36 AND 38). SN 85-184,331. PUB. 6-7-2011. FILED 11-24-2010.
- 4,015,275. **CMPRO AND DESIGN**. PROFESSIONAL SYSTEMS ASSOCIATES, INC., (U.S. CLS. 21, 23, 26, 36 AND 38). SN 85-196,527. PUB. 6-7-2011. FILED 12-13-2010.

- 4,015,278. **O2CPRO (STANDARD CHARACTER)**. WEBCOLLECT, INC., MULTIPLE CLASS, (INT. CLS. 9 AND 42), (U.S. CLS. 21, 23, 26, 36, 38, 100 AND 101). SN 85-197,044. PUB. 6-7-2011. FILED 12-14-2010.
- 4,015,299. **KOGER (STANDARD CHARACTER)**. KOGER, INC., MULTIPLE CLASS, (INT. CLS. 9 AND 42), (U.S. CLS. 21, 23, 26, 36, 38, 100 AND 101). SN 85-200,227. PUB. 6-7-2011. FILED 12-17-2010.
- 4,015,304. **MCP (STANDARD CHARACTER)**. MULTIPLE CHOICES PHOTOGRAPHY LLC, (U.S. CLS. 21, 23, 26, 36 AND 38). SN 85-201,214. PUB. 6-7-2011. FILED 12-18-2010.
- 4,015,333. **ICS (STANDARD CHARACTER)**. INDUSTRIAL COMMERCIAL SCALES, LLC, (U.S. CLS. 21, 23, 26, 36 AND 38). SN 85-204,849. PUB. 6-7-2011. FILED 12-23-2010.
- 4,015,384. **CS CAMERON SINO (STYLIZED)**. CHEUNG YING MAN, (U.S. CLS. 21, 23, 26, 36 AND 38). SN 85-211,510. PUB. 6-7-2011. FILED 1-6-2011.
- 4,015,407. **PUFFIN PAD (STANDARD CHARACTER)**. PUFFIN PHOTO PRODUCTS, LLC, (U.S. CLS. 21, 23, 26, 36 AND 38). SN 85-213,928. PUB. 6-7-2011. FILED 1-10-2011.
- 4,015,418. **DMB (STANDARD CHARACTER)**. BAMA RAGS, INC., (U.S. CLS. 21, 23, 26, 36 AND 38). SN 85-214,645. PUB. 6-7-2011. FILED 1-11-2011.
- 4,015,419. **MISCELLANEOUS DESIGN**. BAMA RAGS, INC., (U.S. CLS. 21, 23, 26, 36 AND 38). SN 85-214,652. PUB. 6-7-2011. FILED 1-11-2011.
- 4,015,429. **VOLVIEW (STANDARD CHARACTER)**. KITWARE, INC., (U.S. CLS. 21, 23, 26, 36 AND 38). SN 85-215,602. PUB. 6-7-2011. FILED 1-12-2011.
- 4,015,433. **SARAH VEDELER DESIGNS (STANDARD CHARACTER)**. SARAH VEDELER ENTERPRISES, LLC, (U.S. CLS. 21, 23, 26, 36 AND 38). SN 85-215,795. PUB. 6-7-2011. FILED 1-12-2011.
- 4,015,448. **NLIGHT (STANDARD CHARACTER)**. NLIGHT PHOTONICS CORPORATION, MULTIPLE CLASS, (INT. CLS. 9 AND 10), (U.S. CLS. 21, 23, 26, 36, 38, 39 AND 44). SN 85-216,920. PUB. 6-7-2011. FILED 1-13-2011.
- 4,015,450. **NLIGHT PHOTONICS (STANDARD CHARACTER)**. NLIGHT PHOTONICS CORPORATION, MULTIPLE CLASS, (INT. CLS. 9 AND 10), (U.S. CLS. 21, 23, 26, 36, 38, 39 AND 44). SN 85-216,972. PUB. 6-7-2011. FILED 1-13-2011.
- 4,015,460 (*See Class 1 for this trademark*).
- 4,015,462. **CLOUD LAW (STANDARD CHARACTER)**. ELLIOT ZIMMERMAN, P.A., (U.S. CLS. 21, 23, 26, 36 AND 38). SN 85-217,608. PUB. 6-7-2011. FILED 1-14-2011.
- 4,015,465. **PBXTEND BEYOND YOUR STANDARD PBX AND DESIGN**. ATLANTA TECHNOLOGY FORCE, INC., (U.S. CLS. 21, 23, 26, 36 AND 38). SN 85-217,772. PUB. 6-7-2011. FILED 1-14-2011.
- 4,015,471. **S 2 (STYLIZED)**. S2 SECURITY CORP., (U.S. CLS. 21, 23, 26, 36 AND 38). SN 85-218,013. PUB. 6-7-2011. FILED 1-14-2011.
- 4,015,472. **S2 NETBOX (STANDARD CHARACTER)**. S2 SECURITY CORP., (U.S. CLS. 21, 23, 26, 36 AND 38). SN 85-218,073. PUB. 6-7-2011. FILED 1-14-2011.
- 4,015,473. **S2 ENTERPRISE (STANDARD CHARACTER)**. S2 SECURITY CORP., (U.S. CLS. 21, 23, 26, 36 AND 38). SN 85-218,103. PUB. 6-7-2011. FILED 1-14-2011.
- 4,015,474. **S2 PRONTO (STANDARD CHARACTER)**. S2 SECURITY CORP., (U.S. CLS. 21, 23, 26, 36 AND 38). SN 85-218,145. PUB. 6-7-2011. FILED 1-14-2011.
- 4,015,480. **ZOLOG (STANDARD CHARACTER)**. XICORO SOFTWARE LTD, (U.S. CLS. 21, 23, 26, 36 AND 38). SN 85-218,602. PUB. 6-7-2011. FILED 1-15-2011.
- 4,015,483. **TRAVELEMERGENCY (STANDARD CHARACTER)**. CALVANDER COMMUNICATIONS, INC., (U.S. CLS. 21, 23, 26, 36 AND 38). SN 85-218,686. PUB. 6-7-2011. FILED 1-15-2011.
- 4,015,500. **THESEKSTER (STANDARD CHARACTER)**. BRADLEY, GRADY A. (U.S. CLS. 21, 23, 26, 36 AND 38). SN 85-219,365. PUB. 6-7-2011. FILED 1-17-2011.
- 4,015,510. **AUDUBON GUIDES (STANDARD CHARACTER)**. NATIONAL AUDUBON SOCIETY, INC., (U.S. CLS. 21, 23, 26, 36 AND 38). SN 85-219,604. PUB. 6-7-2011. FILED 1-18-2011.
- 4,015,512. **DD (STYLIZED)**. RESONANCE, INC., (U.S. CLS. 21, 23, 26, 36 AND 38). SN 85-219,674. PUB. 6-7-2011. FILED 1-18-2011.
- 4,015,515. **SAMTEC AND DESIGN**. SAMTEC INC., (U.S. CLS. 21, 23, 26, 36 AND 38). SN 85-219,707. PUB. 6-7-2011. FILED 1-18-2011.
- 4,015,528. **3IZS (STANDARD CHARACTER)**. PAPPAS, RANDALL J, (U.S. CLS. 21, 23, 26, 36 AND 38). SN 85-220,057. PUB. 6-7-2011. FILED 1-18-2011.
- 4,015,534. **IKANOS VELOCITY (STANDARD CHARACTER)**. IKANOS COMMUNICATIONS, INC., (U.S. CLS. 21, 23, 26, 36 AND 38). SN 85-220,332. PUB. 6-7-2011. FILED 1-18-2011.
- 4,015,577. **SOLAIR TECHNOLOGIES, INC. (STANDARD CHARACTER)**. SOLAIR TECHNOLOGIES, INC. (U.S. CLS. 21, 23, 26, 36 AND 38). SN 85-221,456. PUB. 6-7-2011. FILED 1-19-2011.
- 4,015,585. **CONVERGED GREEN AND DESIGN**. SUMMITRUM COMMUNICATIONS, LLC, DBA CONVERGED GREEN, (U.S. CLS. 21, 23, 26, 36 AND 38). SN 85-221,698. PUB. 6-7-2011. FILED 1-20-2011.
- 4,015,590. **UNDERRIDE (STANDARD CHARACTER)**. WHEN THE WHEELS COME OFF PUBLISHING, DBA UNDER-RIDE, (U.S. CLS. 21, 23, 26, 36 AND 38). SN 85-221,814. PUB. 6-7-2011. FILED 1-20-2011.
- 4,015,598. **PYROMATION INC BEYOND MEASURE AND DESIGN**. PYROMATION, INC., (U.S. CLS. 21, 23, 26, 36 AND 38). SN 85-221,924. PUB. 6-7-2011. FILED 1-20-2011.
- 4,015,600. **G SPORT (STANDARD CHARACTER)**. SHARK EYES, INC., (U.S. CLS. 21, 23, 26, 36 AND 38). SN 85-221,978. PUB. 6-7-2011. FILED 1-20-2011.
- 4,015,601. **OBIX PERINATAL DATA SYSTEM AND DESIGN**. CLINICAL COMPUTER SYSTEMS, INC., (U.S. CLS. 21, 23, 26, 36 AND 38). SN 85-221,986. PUB. 6-7-2011. FILED 1-20-2011.
- 4,015,603. **RXR (STYLIZED)**. SHARK EYES, INC., (U.S. CLS. 21, 23, 26, 36 AND 38). SN 85-222,026. PUB. 6-7-2011. FILED 1-20-2011.
- 4,015,608. **KATURE (STANDARD CHARACTER)**. SHARK EYES, INC., (U.S. CLS. 21, 23, 26, 36 AND 38). SN 85-222,099. PUB. 6-7-2011. FILED 1-20-2011.
- 4,015,620. **HYPER-RIDGE (STANDARD CHARACTER)**. ARAI HELMET AMERICAS, INC., (U.S. CLS. 21, 23, 26, 36 AND 38). SN 85-222,430. PUB. 6-7-2011. FILED 1-20-2011.
- 4,015,625. **DUAL (STANDARD CHARACTER)**. DUAL EYEWEAR LLC, (U.S. CLS. 21, 23, 26, 36 AND 38). SN 85-222,539. PUB. 6-7-2011. FILED 1-20-2011.
- 4,015,631. **CM (STYLIZED)**. CASE-ARI, LLC, DBA CASEMATE, (U.S. CLS. 21, 23, 26, 36 AND 38). SN 85-222,738. PUB. 6-7-2011. FILED 1-20-2011.
- 4,015,635. **DRIVERS A.I.D. (STANDARD CHARACTER)**. FULTON, STEPHEN C., (U.S. CLS. 21, 23, 26, 36 AND 38). SN 85-222,908. PUB. 6-7-2011. FILED 1-21-2011.
- 4,015,648. **REHAB SMART AND DESIGN**. HARDEN THERAPY LLC, DBA MBS REHAB, (U.S. CLS. 21, 23, 26, 36 AND 38). SN 85-223,646. PUB. 6-7-2011. FILED 1-21-2011.
- 4,015,649. **REHAB SMART (STANDARD CHARACTER)**. HARDEN THERAPY LLC, DBA MBS REHAB, (U.S. CLS. 21, 23, 26, 36 AND 38). SN 85-223,647. PUB. 6-7-2011. FILED 1-21-2011.
- 4,015,661. **LEE FLOW CONTROL AND DESIGN**. THE LEE COMPANY, (U.S. CLS. 21, 23, 26, 36 AND 38). SN 85-224,784. PUB. 6-7-2011. FILED 1-24-2011.
- 4,015,664. **CO-DEPENDENTS ANONYMOUS (STANDARD CHARACTER)**. CO-DEPENDENTS ANONYMOUS, INC., MULTIPLE CLASS, (INT. CLS. 9, 16 AND 41), (U.S. CLS. 2, 5, 21, 22, 23, 26, 29, 36, 37, 38, 50, 100, 101 AND 107). SN 85-224,882. PUB. 6-7-2011. FILED 1-24-2011.
- 4,015,666. **MIC ACTIVATOR (STANDARD CHARACTER)**. CLOUD MICROPHONES, (U.S. CLS. 21, 23, 26, 36 AND 38). SN 85-224,919. PUB. 6-7-2011. FILED 1-24-2011.
- 4,015,678. **EASICOLLECT (STANDARD CHARACTER)**. WHATMAN LIMITED, MULTIPLE CLASS, (INT. CLS. 9 AND 10), (U.S. CLS. 21, 23, 26, 36, 38, 39 AND 44). SN 85-225,457. PUB. 6-7-2011. FILED 1-25-2011.
- 4,015,683. **CANTOR (STANDARD CHARACTER)**. CANTOR FITZGERALD SECURITIES, MULTIPLE CLASS, (INT. CLS. 9, 38, 41 AND 42), (U.S. CLS. 21, 23, 26, 36, 38, 100, 101, 104 AND 107). SN 85-225,931. PUB. 6-7-2011. FILED 1-25-2011.
- 4,015,685. **GRENADE WHISTLE (STANDARD CHARACTER)**. BERG, MATTHEW L, DBA TAPULAR, AND WALKER,

- ROBERT B, DBA TAPULAR, (U.S. CLS. 21, 23, 26, 36 AND 38). SN 85-226,142. PUB. 6-7-2011. FILED 1-25-2011.
- 4,015,688. **LEE FLOSER AND DESIGN**. THE LEE COMPANY, (U.S. CLS. 21, 23, 26, 36 AND 38). SN 85-226,277. PUB. 6-7-2011. FILED 1-26-2011.
- 4,015,691. **PIREG (STANDARD CHARACTER)**. TOSS VERPACKUNGSSYSTEME GMBH & CO. KG, (U.S. CLS. 21, 23, 26, 36 AND 38). SN 85-226,437. PUB. 6-7-2011. FILED 1-26-2011.
- 4,015,715. **ICOMPLISHMENTS (STANDARD CHARACTER)**. TAPME, INC., (U.S. CLS. 21, 23, 26, 36 AND 38). SN 85-227,507. PUB. 6-7-2011. FILED 1-27-2011.
- 4,015,718. **SURVEYSWIPE (STANDARD CHARACTER)**. SURVEY ANALYTICS, LLC, (U.S. CLS. 21, 23, 26, 36 AND 38). SN 85-227,621. PUB. 6-7-2011. FILED 1-27-2011.
- 4,015,721. **TOY TIME (STANDARD CHARACTER)**. CALIFORNIA EXOTIC NOVELTIES LLC, (U.S. CLS. 21, 23, 26, 36 AND 38). SN 85-227,830. PUB. 6-7-2011. FILED 1-27-2011.
- 4,015,722. **SURVEYPOCKET (STANDARD CHARACTER)**. SURVEY ANALYTICS, LLC, (U.S. CLS. 21, 23, 26, 36 AND 38). SN 85-227,834. PUB. 6-7-2011. FILED 1-27-2011.
- 4,015,731. **LIMO ANYWHERE (STANDARD CHARACTER)**. LIMO ANYWHERE, INC., MULTIPLE CLASS, (INT. CLS. 9 AND 35), (U.S. CLS. 21, 23, 26, 36, 38, 100, 101 AND 102). SN 85-228,146. PUB. 6-7-2011. FILED 1-27-2011.
- 4,015,733. **SP AND DESIGN**. CODEGEN TECHNOLOGY CO., LTD., (U.S. CLS. 21, 23, 26, 36 AND 38). SN 85-228,420. PUB. 6-7-2011. FILED 1-28-2011.
- 4,015,746. **ANGRY TURDS (STANDARD CHARACTER)**. APPS GENIUS CORP., (U.S. CLS. 21, 23, 26, 36 AND 38). SN 85-228,581. PUB. 6-7-2011. FILED 1-28-2011.
- 4,015,749. **LEE SHUTTLE AND DESIGN**. THE LEE COMPANY, (U.S. CLS. 21, 23, 26, 36 AND 38). SN 85-228,663. PUB. 6-7-2011. FILED 1-28-2011.
- 4,015,753. **FEMNAV (STANDARD CHARACTER)**. FEMNAV LLC, (U.S. CLS. 21, 23, 26, 36 AND 38). SN 85-228,701. PUB. 6-7-2011. FILED 1-28-2011.
- 4,015,774. **IT'S ALL GOOD AND DESIGN**. MILITTI SALES & PROMOTIONS, LLC, (U.S. CLS. 21, 23, 26, 36 AND 38). SN 85-228,974. PUB. 6-7-2011. FILED 1-28-2011.
- 4,015,776. **COOLSYSTEM (STANDARD CHARACTER)**. BIOCISION, LLC, (U.S. CLS. 21, 23, 26, 36 AND 38). SN 85-229,000. PUB. 6-7-2011. FILED 1-28-2011.
- 4,015,793. **PLANSARK (STANDARD CHARACTER)**. PLANSARK LLC, (U.S. CLS. 21, 23, 26, 36 AND 38). SN 85-229,179. PUB. 6-7-2011. FILED 1-28-2011.
- 4,015,796. **ACETHETIC (STANDARD CHARACTER)**. JOSHUA C. CUMMINGS, DBA ACETHETIC, (U.S. CLS. 21, 23, 26, 36 AND 38). SN 85-229,215. PUB. 6-7-2011. FILED 1-28-2011.
- 4,015,802. **LINEBACKER (STANDARD CHARACTER)**. WELLS LAMONT INDUSTRY GROUP LLC, (U.S. CLS. 21, 23, 26, 36 AND 38). SN 85-229,343. PUB. 6-7-2011. FILED 1-28-2011.
- 4,015,810. **WILD FACTOR (STANDARD CHARACTER)**. LAUTIE ALEXANDRE, (U.S. CLS. 21, 23, 26, 36 AND 38). SN 85-229,444. PUB. 6-7-2011. FILED 1-29-2011.
- 4,015,812. **SIP SMART (STANDARD CHARACTER)**. GOLDSTEIN, ROBERT, (U.S. CLS. 21, 23, 26, 36 AND 38). SN 85-229,500. PUB. 6-7-2011. FILED 1-29-2011.
- 4,015,817. **DISCIPLE OF THE KING (STANDARD CHARACTER)**. VINEGAR, DEREK LEE, AKA DISCIPLE OF THE KING, (U.S. CLS. 21, 23, 26, 36 AND 38). SN 85-229,534. PUB. 6-7-2011. FILED 1-29-2011.
- 4,015,837. **CLICKMEIN (STANDARD CHARACTER)**. CLICKMEIN LIMITED, (U.S. CLS. 21, 23, 26, 36 AND 38). SN 85-229,869. PUB. 6-7-2011. FILED 1-31-2011.
- 4,015,845. **DRCLOUDEMR (STANDARD CHARACTER)**. EN-SOFTEK, INC., MULTIPLE CLASS, (INT. CLS. 9 AND 42), (U.S. CLS. 21, 23, 26, 36, 38, 100 AND 101). SN 85-229,953. PUB. 6-7-2011. FILED 1-31-2011.
- 4,015,870. **FM AND DESIGN**. GLENN ZANDERS FUR & SPORTING GOODS CO., AND DKG TRADING, INC., (U.S. CLS. 21, 23, 26, 36 AND 38). SN 85-230,437. PUB. 6-7-2011. FILED 1-31-2011.
- 4,015,875. **DATAFAB AND DESIGN**. DATAFAB SYSTEMS, INC., (U.S. CLS. 21, 23, 26, 36 AND 38). SN 85-230,488. PUB. 6-7-2011. FILED 1-31-2011.
- 4,015,876. **PPAS (STANDARD CHARACTER)**. APPLIED AERONAUTICAL SYSTEMS, INC., (U.S. CLS. 21, 23, 26, 36 AND 38). SN 85-230,497. PUB. 6-7-2011. FILED 1-31-2011.
- 4,015,886. **CONCAVUS (STANDARD CHARACTER)**. CONCAVUS INC., (U.S. CLS. 21, 23, 26, 36 AND 38). SN 85-230,623. PUB. 6-7-2011. FILED 1-31-2011.
- 4,015,916. **AQUEDUCT (STANDARD CHARACTER)**. KIEFFER BROS., LLC, (U.S. CLS. 21, 23, 26, 36 AND 38). SN 85-231,044. PUB. 6-7-2011. FILED 2-1-2011.
- 4,015,922. **T-SOAK (STANDARD CHARACTER)**. MICHAEL CARTER, (U.S. CLS. 21, 23, 26, 36 AND 38). SN 85-231,146. PUB. 6-7-2011. FILED 2-1-2011.
- 4,015,923. **DECIDE-O-TRON (STANDARD CHARACTER)**. PENNY ARCADE, (U.S. CLS. 21, 23, 26, 36 AND 38). SN 85-231,157. PUB. 6-7-2011. FILED 2-1-2011.
- 4,015,928. **R RODIA AND DESIGN**. BEIJING AJHX HELMET TECHNOLOGY & TRADE CO., LTD., (U.S. CLS. 21, 23, 26, 36 AND 38). SN 85-231,207. PUB. 6-7-2011. FILED 2-1-2011.
- 4,015,934. **ULIFE (STANDARD CHARACTER)**. ULIFE LTD, (U.S. CLS. 21, 23, 26, 36 AND 38). SN 85-231,256. PUB. 6-7-2011. FILED 2-1-2011.
- 4,015,940. **TURBOSUN (STANDARD CHARACTER)**. ASPEx GROUP INC., (U.S. CLS. 21, 23, 26, 36 AND 38). SN 85-231,480. PUB. 6-7-2011. FILED 2-1-2011.
- 4,015,953. **SECUREENTRY (STANDARD CHARACTER)**. PRIMESYS, LP, (U.S. CLS. 21, 23, 26, 36 AND 38). SN 85-231,703. PUB. 6-7-2011. FILED 2-1-2011.
- 4,015,957. **SLASHLINE (STANDARD CHARACTER)**. REX T. BURDETT, (U.S. CLS. 21, 23, 26, 36 AND 38). SN 85-231,753. PUB. 6-7-2011. FILED 2-1-2011.
- 4,015,971. **ODYSSEY TRANSLATOR (STANDARD CHARACTER)**. ODYSSEY TRANSLATOR, LLC, (U.S. CLS. 21, 23, 26, 36 AND 38). SN 85-232,008. PUB. 6-7-2011. FILED 2-2-2011.
- 4,015,973. **ROCAWEAR (STANDARD CHARACTER)**. STUDIO IP HOLDINGS, LLC, (U.S. CLS. 21, 23, 26, 36 AND 38). SN 85-232,064. PUB. 6-7-2011. FILED 2-2-2011.
- 4,015,975. **PURESEAL (STANDARD CHARACTER)**. POLARIS INDUSTRIES INC., (U.S. CLS. 21, 23, 26, 36 AND 38). SN 85-232,098. PUB. 6-7-2011. FILED 2-2-2011.
- 4,015,982. **ACROPOLIS (STANDARD CHARACTER)**. THE HOEFLER TYPE FOUNDRY, INC., DBA HOEFLER & FRERE-JONES, (U.S. CLS. 21, 23, 26, 36 AND 38). SN 85-232,361. PUB. 6-7-2011. FILED 2-2-2011.
- 4,015,996. **VISITREND (STANDARD CHARACTER)**. VISITREND, LLC, (U.S. CLS. 21, 23, 26, 36 AND 38). SN 85-232,477. PUB. 6-7-2011. FILED 2-2-2011.
- 4,016,017. **AUGEN 1.0 (STANDARD CHARACTER)**. AUGEN OPTICOS, S.A. DE C.V., (U.S. CLS. 21, 23, 26, 36 AND 38). SN 85-232,787. PUB. 6-7-2011. FILED 2-2-2011.
- 4,016,019. **FOXCAD (STANDARD CHARACTER)**. REDPUP LLC, (U.S. CLS. 21, 23, 26, 36 AND 38). SN 85-232,833. PUB. 6-7-2011. FILED 2-2-2011.
- 4,016,020. **GET YOUR TECH WET! (STANDARD CHARACTER)**. HEIM, COREY, (U.S. CLS. 21, 23, 26, 36 AND 38). SN 85-232,876. PUB. 6-7-2011. FILED 2-3-2011.
- 4,016,036. **1080PERFECT (STANDARD CHARACTER)**. WIREWORLD BY DAVID SALZ, INC., (U.S. CLS. 21, 23, 26, 36 AND 38). SN 85-233,302. PUB. 6-7-2011. FILED 2-3-2011.
- 4,016,040. **WEBCATI (STANDARD CHARACTER)**. COMPUTERS FOR MARKETING CORPORATION, DBA CFMC, (U.S. CLS. 21, 23, 26, 36 AND 38). SN 85-233,486. PUB. 6-7-2011. FILED 2-3-2011.
- 4,016,045. **CYCLONE (STANDARD CHARACTER)**. THE HOEFLER TYPE FOUNDRY, INC., DBA HOEFLER & FRERE-JONES, (U.S. CLS. 21, 23, 26, 36 AND 38). SN 85-233,566. PUB. 6-7-2011. FILED 2-3-2011.
- 4,016,049. **H&FJ DIDOT (STANDARD CHARACTER)**. THE HOEFLER TYPE FOUNDRY, INC., DBA HOEFLER & FRERE-JONES, (U.S. CLS. 21, 23, 26, 36 AND 38). SN 85-233,592. PUB. 6-7-2011. FILED 2-3-2011.
- 4,016,051. **GIANT (STANDARD CHARACTER)**. THE HOEFLER TYPE FOUNDRY, INC., DBA HOEFLER & FRERE-JONES, (U.S. CLS. 21, 23, 26, 36 AND 38). SN 85-233,615. PUB. 6-7-2011. FILED 2-3-2011.
- 4,016,067. **MORE TALK, NO BILLS! (STANDARD CHARACTER)**. NET TALK.COM, INC., (U.S. CLS. 21, 23, 26, 36 AND 38). SN 85-238,609. PUB. 6-7-2011. FILED 2-10-2011.
- 4,016,074. **MISCELLANEOUS DESIGN**. KISS CATALOG, LTD., (U.S. CLS. 21, 23, 26, 36 AND 38). SN 85-239,285. PUB. 6-7-2011. FILED 2-10-2011.

- 4,016,075. **MISCELLANEOUS DESIGN**. KISS CATALOG, LTD., (U.S. CLS. 21, 23, 26, 36 AND 38). SN 85-239,299. PUB. 6-7-2011. FILED 2-10-2011.
- 4,016,076. **MISCELLANEOUS DESIGN**. KISS CATALOG, LTD., (U.S. CLS. 21, 23, 26, 36 AND 38). SN 85-239,312. PUB. 6-7-2011. FILED 2-10-2011.
- 4,016,077. **MISCELLANEOUS DESIGN**. KISS CATALOG, LTD., (U.S. CLS. 21, 23, 26, 36 AND 38). SN 85-239,324. PUB. 6-7-2011. FILED 2-10-2011.
- 4,016,079. **CAPELLA TECHNOLOGIES AND DESIGN**. CAPELLA TECHNOLOGIES, INC., (U.S. CLS. 21, 23, 26, 36 AND 38). SN 85-241,386. PUB. 6-7-2011. FILED 2-14-2011.
- 4,016,086. **COMPOSIX (STANDARD CHARACTER)**. WIREWORLD BY DAVID SALZ, INC., (U.S. CLS. 21, 23, 26, 36 AND 38). SN 85-245,759. PUB. 6-7-2011. FILED 2-18-2011.
- 4,016,087. **FANDIRECT (STANDARD CHARACTER)**. MLB ADVANCED MEDIA, L.P., MULTIPLE CLASS, (INT. CLS. 9 AND 35), (U.S. CLS. 21, 23, 26, 36, 38, 100, 101 AND 102). SN 85-245,929. PUB. 6-7-2011. FILED 2-18-2011.
- 4,016,092. **DS200 (STANDARD CHARACTER)**. ES&S INNOVATIONS, LLC, (U.S. CLS. 21, 23, 26, 36 AND 38). SN 85-249,352. PUB. 6-7-2011. FILED 2-23-2011.
- 4,016,106. **SUPER CAM AND DESIGN**. WEBPOWER, INC., (U.S. CLS. 21, 23, 26, 36 AND 38). SN 85-256,927. PUB. 6-7-2011. FILED 3-3-2011.
- 4,016,110. **BAMBULIFE (STANDARD CHARACTER)**. ULIFE LTD, (U.S. CLS. 21, 23, 26, 36 AND 38). SN 85-260,195. PUB. 6-7-2011. FILED 3-7-2011.
- 4,016,117. **TWEAK ON (STANDARD CHARACTER)**. LAUGHING SOFTWARE, LLC, (U.S. CLS. 21, 23, 26, 36 AND 38). SN 85-263,880. PUB. 6-7-2011. FILED 3-10-2011.
- 4,016,118. **LUCKY 11'S (STANDARD CHARACTER)**. AMI ENTERTAINMENT NETWORK, INC., (U.S. CLS. 21, 23, 26, 36 AND 38). SN 85-264,500. PUB. 6-7-2011. FILED 3-11-2011.
- 4,016,134. **WOLVES AND DESIGN**. BOARD OF REGENTS OF THE UNIVERSITY SYSTEM OF GEORGIA, MULTIPLE CLASS, (INT. CLS. 9 AND 41), (U.S. CLS. 21, 23, 26, 36, 38, 100, 101 AND 107). SN 85-286,331. PUB. 6-7-2011. FILED 4-5-2011.
- 4,016,136. **M3D (STANDARD CHARACTER)**. MARCHON EYEWEAR, INC., (U.S. CLS. 21, 23, 26, 36 AND 38). SN 85-290,061. PUB. 6-7-2011. FILED 4-8-2011.

CLASS 10—MEDICAL APPARATUS

- 4,014,243. **TRUTONE (STANDARD CHARACTER)**. GRIFFIN LABORATORIES, (U.S. CLS. 26, 39 AND 44). SN 76-706,512. PUB. 6-7-2011. FILED 2-22-2011.
- 4,014,244. **SOLATONE (STANDARD CHARACTER)**. GRIFFIN LABORATORIES, (U.S. CLS. 26, 39 AND 44). SN 76-706,513. PUB. 6-7-2011. FILED 2-22-2011.
- 4,014,250 (*See Class 9 for this trademark*).
- 4,014,256. **CYBERTECH (STANDARD CHARACTER)**. BIO CYBERNETICS INTERNATIONAL, (U.S. CLS. 26, 39 AND 44). SN 77-373,143. PUB. 6-7-2011. FILED 1-16-2008.
- 4,014,312 (*See Class 9 for this trademark*).
- 4,014,320 (*See Class 1 for this trademark*).
- 4,014,424. **MARENA (STANDARD CHARACTER)**. MARLENA INTERNATIONAL, LLC, MULTIPLE CLASS, (INT. CLS. 10 AND 25), (U.S. CLS. 22, 26, 39 AND 44). SN 77-966,235. PUB. 6-7-2011. FILED 3-23-2010.
- 4,014,429 (*See Class 3 for this trademark*).
- 4,014,432 (*See Class 3 for this trademark*).
- 4,014,449. **XIGN (STANDARD CHARACTER)**. DR. IHDE DENTAL AG, (U.S. CLS. 26, 39 AND 44). SN 79-040,862. PUB. 4-15-2008. FILED 5-23-2007.
- 4,014,488 (*See Class 7 for this trademark*).
- 4,014,498 (*See Class 9 for this trademark*).
- 4,014,506 (*See Class 1 for this trademark*).
- 4,014,523. **CYTOSPONGE (STANDARD CHARACTER)**. MEDICAL RESEARCH COUNCIL, (U.S. CLS. 26, 39 AND 44). SN 79-085,471. PUB. 6-7-2011. FILED 7-1-2010.
- 4,014,540. **VISIOFOCUS (STANDARD CHARACTER)**. TECNIMED SRL, (U.S. CLS. 26, 39 AND 44). SN 79-086,170. PUB. 6-7-2011. FILED 6-24-2010.
- 4,014,565. **GRILAMID TR (STANDARD CHARACTER)**. EMS-PATENT AG, MULTIPLE CLASS, (INT. CLS. 10, 14 AND 28), (U.S. CLS. 2, 22, 23, 26, 27, 28, 38, 39, 44 AND 50). SN 79-087,435. PUB. 6-7-2011. FILED 8-30-2010.
- 4,014,574. **RESUS-EZY (STANDARD CHARACTER)**. ENDONATIONS PTY LTD, (U.S. CLS. 26, 39 AND 44). SN 79-088,248. PUB. 6-7-2011. FILED 9-21-2010.
- 4,014,606 (*See Class 3 for this trademark*).
- 4,014,612 (*See Class 3 for this trademark*).
- 4,014,613 (*See Class 3 for this trademark*).
- 4,014,620. **POLYMOTION (STANDARD CHARACTER)**. MR DEREK MCMINN, (U.S. CLS. 26, 39 AND 44). SN 79-091,152. PUB. 6-7-2011. FILED 11-30-2010.
- 4,014,626. **OERTLI AND DESIGN**. OERTLI INSTRUMENTE AG, (U.S. CLS. 26, 39 AND 44). SN 79-091,520. PUB. 6-7-2011. FILED 11-15-2010.
- 4,014,781. **KUMAR CLAMP (STANDARD CHARACTER)**. NASHVILLE SURGICAL INSTRUMENTS, (U.S. CLS. 26, 39 AND 44). SN 85-066,904. PUB. 6-7-2011. FILED 6-18-2010.
- 4,014,784. **LYONS (STANDARD CHARACTER)**. LYONS, THOMAS, (U.S. CLS. 26, 39 AND 44). SN 85-067,612. PUB. 6-7-2011. FILED 6-21-2010.
- 4,014,791 (*See Class 5 for this trademark*).
- 4,014,792 (*See Class 5 for this trademark*).
- 4,014,817. **K3GEL AND DESIGN**. KAYFOAM WOOLFSON, MULTIPLE CLASS, (INT. CLS. 10 AND 20), (U.S. CLS. 2, 13, 22, 25, 26, 32, 39, 44 AND 50). SN 85-075,093. PUB. 6-7-2011. FILED 6-30-2010.
- 4,014,938. **TRU-SIZE (STANDARD CHARACTER)**. BAUSCH & LOMB INCORPORATED, (U.S. CLS. 26, 39 AND 44). SN 85-099,269. PUB. 6-7-2011. FILED 8-3-2010.
- 4,015,067. **ASEPT (STANDARD CHARACTER)**. PFM MEDICAL, INC., (U.S. CLS. 26, 39 AND 44). SN 85-138,106. PUB. 3-1-2011. FILED 9-24-2010.
- 4,015,139. **I MY ORTHOTICS! AND DESIGN**. FOOT IN MOTION, INC., MULTIPLE CLASS, (INT. CLS. 10 AND 44), (U.S. CLS. 26, 39, 44, 100 AND 101). SN 85-159,034. PUB. 6-7-2011. FILED 10-22-2010.
- 4,015,154 (*See Class 5 for this trademark*).
- 4,015,211. **SPERMOCYTOMETER (STANDARD CHARACTER)**. FERTILITY SOLUTIONS, INC., (U.S. CLS. 26, 39 AND 44). SN 85-181,021. PUB. 6-7-2011. FILED 11-19-2010.
- 4,015,289. **NEORAY (STANDARD CHARACTER)**. 5 STAR MEDICAL LLC, (U.S. CLS. 26, 39 AND 44). SN 85-198,356. PUB. 6-7-2011. FILED 12-15-2010.
- 4,015,346 (*See Class 7 for this trademark*).
- 4,015,448 (*See Class 9 for this trademark*).
- 4,015,450 (*See Class 9 for this trademark*).
- 4,015,532. **NETBRACE (STANDARD CHARACTER)**. DURABLE ORTHOPAEDIC SUPPLIES, LLC, (U.S. CLS. 26, 39 AND 44). SN 85-220,216. PUB. 6-7-2011. FILED 1-18-2011.
- 4,015,589. **RAD BOARD (STANDARD CHARACTER)**. RADIAL ASSIST, LLC, (U.S. CLS. 26, 39 AND 44). SN 85-221,747. PUB. 6-7-2011. FILED 1-20-2011.
- 4,015,678 (*See Class 9 for this trademark*).
- 4,015,735. **RELIEVE YOUR PAIN, RENEW YOUR LIFE (STANDARD CHARACTER)**. BROWN MEDICAL INDUSTRIES, INC., (U.S. CLS. 26, 39 AND 44). SN 85-228,476. PUB. 6-7-2011. FILED 1-28-2011.
- 4,015,773. **ALTO (STANDARD CHARACTER)**. U.S. ORTHOTICS, INC., (U.S. CLS. 26, 39 AND 44). SN 85-228,970. PUB. 6-7-2011. FILED 1-28-2011.
- 4,015,866. **ENCOR (STANDARD CHARACTER)**. C. R. BARD, INC., (U.S. CLS. 26, 39 AND 44). SN 85-230,363. PUB. 6-7-2011. FILED 1-31-2011.
- 4,015,898. **DURAFORM (STANDARD CHARACTER)**. KIM, PAUL, DBA US ORTHODONTIC PRODUCT, (U.S. CLS. 26, 39 AND 44). SN 85-230,789. PUB. 6-7-2011. FILED 2-1-2011.

CLASS 11—ENVIRONMENTAL CONTROL APPARATUS

- 4,014,237. **SINMAG (STANDARD CHARACTER)**. SINMAG EQUIPMENT CORPORATION, (U.S. CLS. 13, 21, 23, 31 AND 34). SN 76-706,225. PUB. 6-7-2011. FILED 2-1-2011.

- 4,014,247 (*See Class 9 for this trademark.*)
 4,014,252 (*See Class 9 for this trademark.*)
 4,014,262. **ECOLIGHT (STANDARD CHARACTER)**. GOOD EARTH LIGHTING, INC., (U.S. CLS. 13, 21, 23, 31 AND 34). SN 77-497,214. PUB. 6-7-2011. FILED 6-12-2008.
 4,014,314 (*See Class 6 for this trademark.*)
 4,014,323. **KOMTEK DELUXE AND DESIGN**. KOMPASS TECHNOLOGY CO., LTD., (U.S. CLS. 13, 21, 23, 31 AND 34). SN 77-775,611. PUB. 6-7-2011. FILED 7-7-2009.
 4,014,329. **OKP (STANDARD CHARACTER)**. F.W. OVENTROP GMBH & CO.KG, (U.S. CLS. 13, 21, 23, 31 AND 34). SN 77-810,040. PUB. 6-1-2010. FILED 8-21-2009.
 4,014,333. **ECORAD (STANDARD CHARACTER)**. ECORAD INC., MULTIPLE CLASS, (INT. CLS. 11, 37 AND 42), (U.S. CLS. 13, 21, 23, 31, 34, 100, 101, 103 AND 106). SN 77-818,784. PUB. 6-7-2011. FILED 9-2-2009.
 4,014,349. **CURE-TEK (STANDARD CHARACTER)**. H & S AUTOSHOT MFG. CO. LTD., (U.S. CLS. 13, 21, 23, 31 AND 34). SN 77-857,676. PUB. 6-7-2011. FILED 10-26-2009.
 4,014,447 (*See Class 9 for this trademark.*)
 4,014,452 (*See Class 6 for this trademark.*)
 4,014,461. **GESSNER (STANDARD CHARACTER)**. NEENAH GESSNER GMBH, MULTIPLE CLASS, (INT. CLS. 11, 16 AND 17), (U.S. CLS. 1, 2, 5, 12, 13, 21, 22, 23, 29, 31, 34, 35, 37, 38 AND 50). SN 79-074,601. PUB. 6-7-2011. FILED 9-18-2009.
 4,014,468 (*See Class 4 for this trademark.*)
 4,014,472. **COMPASS AND DESIGN**. MEWETT PROPERTY PTY LTD, MULTIPLE CLASS, (INT. CLS. 11 AND 19), (U.S. CLS. 1, 12, 13, 21, 23, 31, 33, 34 AND 50). SN 79-078,700. PUB. 6-7-2011. FILED 1-13-2010.
 4,014,506 (*See Class 1 for this trademark.*)
 4,014,541. **MAREL (STANDARD CHARACTER)**. MAREL HF, (U.S. CLS. 13, 21, 23, 31 AND 34). SN 79-086,212. PUB. 6-7-2011. FILED 4-20-2010.
 4,014,542. **LUMIWARE (STANDARD CHARACTER)**. KONINKLIJKE PHILIPS ELECTRONICS N.V., MULTIPLE CLASS, (INT. CLS. 11, 21 AND 28), (U.S. CLS. 2, 13, 21, 22, 23, 29, 30, 31, 33, 34, 38, 40 AND 50). SN 79-086,256. PUB. 6-7-2011. FILED 6-23-2010.
 4,014,548. **ETS AND DESIGN**. ATG UV TECHNOLOGY LIMITED, (U.S. CLS. 13, 21, 23, 31 AND 34). SN 79-086,739. PUB. 6-7-2011. FILED 1-19-2010.
 4,014,549. **MISCELLANEOUS DESIGN**. ATG UV TECHNOLOGY LIMITED, (U.S. CLS. 13, 21, 23, 31 AND 34). SN 79-086,740. PUB. 6-7-2011. FILED 1-19-2010.
 4,014,569 (*See Class 7 for this trademark.*)
 4,014,582 (*See Class 9 for this trademark.*)
 4,014,598. **BARBELETTE (STANDARD CHARACTER)**. BOS KAASGEREEDSCHAPPEN B.V., MULTIPLE CLASS, (INT. CLS. 11, 21 AND 25), (U.S. CLS. 2, 13, 21, 22, 23, 29, 30, 31, 33, 34, 39, 40 AND 50). SN 79-089,878. PUB. 6-7-2011. FILED 8-31-2010.
 4,014,611. **PIROLED (STANDARD CHARACTER)**. OSRAM GESELLSCHAFT MIT BESCHRÄNKTER HAFTUNG, (U.S. CLS. 13, 21, 23, 31 AND 34). SN 79-090,633. PUB. 6-7-2011. FILED 12-1-2010.
 4,014,629 (*See Class 7 for this trademark.*)
 4,014,639. **GABAG (STANDARD CHARACTER)**. URS GASSMANN, MULTIPLE CLASS, (INT. CLS. 11, 35 AND 44), (U.S. CLS. 13, 21, 23, 31, 34, 100, 101 AND 102). SN 79-092,939. PUB. 6-7-2011. FILED 9-27-2010.
 4,014,646. **I (STYLIZED)**. HARWOOD INDUSTRIES S.A., (U.S. CLS. 13, 21, 23, 31 AND 34). SN 79-093,858. PUB. 6-7-2011. FILED 10-25-2010.
 4,014,649. **PG AND DESIGN**. MANUEL OSTNER, MULTIPLE CLASS, (INT. CLS. 11, 12 AND 41), (U.S. CLS. 13, 19, 21, 23, 31, 34, 35, 44, 100, 101 AND 107). SN 79-094,660. PUB. 6-7-2011. FILED 3-24-2010.
 4,014,785. **SOLELECTRIC (STANDARD CHARACTER)**. RENCON ENERGY PRODUCTS INC., (U.S. CLS. 13, 21, 23, 31 AND 34). SN 85-067,793. PUB. 6-7-2011. FILED 6-21-2010.
 4,014,862. **PETRECO (STANDARD CHARACTER)**. PETRECO INTERNATIONAL, INC., (U.S. CLS. 13, 21, 23, 31 AND 34). SN 85-082,960. PUB. 6-7-2011. FILED 7-13-2010.
 4,014,877. **EASCOOK AND DESIGN**. ZHONGSHAN DONLIM WEILI ELECTRICAL APPLIANCES CO., LTD., (U.S. CLS. 13, 21, 23, 31 AND 34). SN 85-087,257. PUB. 6-7-2011. FILED 7-18-2010.
 4,014,939. **ALKASTREAM (STANDARD CHARACTER)**. HAMILTON, IAN BLAIR, (U.S. CLS. 13, 21, 23, 31 AND 34). SN 85-099,555. PUB. 6-7-2011. FILED 8-4-2010.
 4,015,144 (*See Class 6 for this trademark.*)
 4,015,294. **BIOMEDIA GREEN (STANDARD CHARACTER)**. MODULAR WETLAND SYSTEMS, INC., (U.S. CLS. 13, 21, 23, 31 AND 34). SN 85-199,886. PUB. 6-7-2011. FILED 12-16-2010.
 4,015,295. **BIOMEDIA GREEN AND DESIGN**. MODULAR WETLAND SYSTEMS, INC., (U.S. CLS. 13, 21, 23, 31 AND 34). SN 85-199,919. PUB. 6-7-2011. FILED 12-16-2010.
 4,015,298. **CHIMNEYFREE (STANDARD CHARACTER)**. TWIN STAR INTERNATIONAL, INC., (U.S. CLS. 13, 21, 23, 31 AND 34). SN 85-200,173. PUB. 6-7-2011. FILED 12-17-2010.
 4,015,389. **INSULATION MAX (STANDARD CHARACTER)**. PLASTIC PROCESS EQUIPMENT, INC., (U.S. CLS. 13, 21, 23, 31 AND 34). SN 85-211,899. PUB. 6-7-2011. FILED 1-6-2011.
 4,015,421. **THINKTANK TECHNOLOGY (STANDARD CHARACTER)**. YONG LI, (U.S. CLS. 13, 21, 23, 31 AND 34). SN 85-214,725. PUB. 6-7-2011. FILED 1-11-2011.
 4,015,434. **PLANT AIR PURIFIER AND DESIGN**. U.S. HEALTH EQUIPMENT COMPANY, INC., (U.S. CLS. 13, 21, 23, 31 AND 34). SN 85-215,798. PUB. 6-7-2011. FILED 1-12-2011.
 4,015,618. **AQUAZERVE AND DESIGN**. DENNIS KENTCH, (U.S. CLS. 13, 21, 23, 31 AND 34). SN 85-222,395. PUB. 6-7-2011. FILED 1-20-2011.
 4,015,658. **UTG (STANDARD CHARACTER)**. LEAPERS, INC., (U.S. CLS. 13, 21, 23, 31 AND 34). SN 85-224,602. PUB. 6-7-2011. FILED 1-24-2011.
 4,015,709. **PROFILUX PLUS (STYLIZED)**. MULTIBLITZ USA, TA MULTIBLITZ USA, (U.S. CLS. 13, 21, 23, 31 AND 34). SN 85-227,159. PUB. 6-7-2011. FILED 1-26-2011.
 4,015,799. **UNICEL (STANDARD CHARACTER)**. MEISSNER MFG. CO., INC., (U.S. CLS. 13, 21, 23, 31 AND 34). SN 85-229,299. PUB. 6-7-2011. FILED 1-28-2011.
 4,016,095. **XL50 (STANDARD CHARACTER)**. MAG INSTRUMENT, INC., (U.S. CLS. 13, 21, 23, 31 AND 34). SN 85-250,771. PUB. 6-7-2011. FILED 2-24-2011.
 4,016,096. **XL200 (STANDARD CHARACTER)**. MAG INSTRUMENT, INC., (U.S. CLS. 13, 21, 23, 31 AND 34). SN 85-250,785. PUB. 6-7-2011. FILED 2-24-2011.
 4,016,097. **BLAZE (STANDARD CHARACTER)**. CAO GROUP, INC., (U.S. CLS. 13, 21, 23, 31 AND 34). SN 85-251,205. PUB. 6-7-2011. FILED 2-24-2011.
 4,016,119. **THINLINE (STANDARD CHARACTER)**. CARRIER CORPORATION, (U.S. CLS. 13, 21, 23, 31 AND 34). SN 85-265,947. PUB. 6-7-2011. FILED 3-14-2011.
-
- CLASS 12—VEHICLES**
- 4,014,452 (*See Class 6 for this trademark.*)
 4,014,474 (*See Class 9 for this trademark.*)
 4,014,486 (*See Class 4 for this trademark.*)
 4,014,493 (*See Class 7 for this trademark.*)
 4,014,506 (*See Class 1 for this trademark.*)
 4,014,518. **Y YCF AND DESIGN**. SAS FAYA, MULTIPLE CLASS, (INT. CLS. 12, 16 AND 25), (U.S. CLS. 2, 5, 19, 21, 22, 23, 29, 31, 35, 37, 38, 39, 44 AND 50). SN 79-085,174. PUB. 6-7-2011. FILED 6-2-2010.
 4,014,545. **EBRETTI (STANDARD CHARACTER)**. AD-CLICX B.V., MULTIPLE CLASS, (INT. CLS. 12 AND 25), (U.S. CLS. 19, 21, 22, 23, 31, 35, 39 AND 44). SN 79-086,601. PUB. 6-7-2011. FILED 7-15-2010.
 4,014,586. **PHORM (STANDARD CHARACTER)**. FRANC ARNOLD, (U.S. CLS. 19, 21, 23, 31, 35 AND 44). SN 79-089,044. PUB. 6-7-2011. FILED 10-13-2010.
 4,014,609 (*See Class 6 for this trademark.*)
 4,014,649 (*See Class 11 for this trademark.*)
 4,014,667. **HERLAG (STYLIZED)**. HERLAG HOLZWARENFABRIK GMBH & CO. KG, MULTIPLE CLASS, (INT. CLS. 12 AND 20), (U.S. CLS. 2, 13, 19, 21, 22, 23, 25, 31, 32, 35, 44 AND 50). SN 79-095,826. PUB. 6-7-2011. FILED 12-16-2010.
 4,014,754. **MISKA (STANDARD CHARACTER)**. 2055495 ON-

TARIO, INC., (U.S. CLS. 19, 21, 23, 31, 35 AND 44). SN 85-060,867. PUB. 6-7-2011. FILED 6-11-2010.

4,014,782. **VANGUARD (STANDARD CHARACTER)**. BRODA ENTERPRISES INC., (U.S. CLS. 19, 21, 23, 31, 35 AND 44). SN 85-067,300. PUB. 6-7-2011. FILED 6-21-2010.

4,014,866 (*See Class 7 for this trademark*).

4,015,056. **QUAKE COTTAGE (STANDARD CHARACTER)**. ESSRIG, MICHAEL, (U.S. CLS. 19, 21, 23, 31, 35 AND 44). SN 85-136,048. PUB. 6-7-2011. FILED 9-22-2010.

4,015,065 (*See Class 9 for this trademark*).

4,015,199. **MISCELLANEOUS DESIGN**. EVERGREEN AUTOMOTIVE PERFORMANCE INDUSTRIES, INC., (U.S. CLS. 19, 21, 23, 31, 35 AND 44). SN 85-177,638. PUB. 6-7-2011. FILED 11-16-2010.

4,015,496. **MEGA HITCH AND DESIGN**. CLEARWATER INDUSTRIES, LLC, (U.S. CLS. 19, 21, 23, 31, 35 AND 44). SN 85-219,263. PUB. 6-7-2011. FILED 1-17-2011.

4,015,614. **PONY EXPRESS (STANDARD CHARACTER)**. ELECTRO KINETIC TECHNOLOGIES, LLC, (U.S. CLS. 19, 21, 23, 31, 35 AND 44). SN 85-222,345. PUB. 6-7-2011. FILED 1-20-2011.

4,015,711. **J.R.C. ENGINEERING (STANDARD CHARACTER)**. GETTY, WILLIAM, (U.S. CLS. 19, 21, 23, 31, 35 AND 44). SN 85-227,168. PUB. 6-7-2011. FILED 1-26-2011.

4,015,754. **CONVAID AND DESIGN**. CONVAID PRODUCTS, INC., (U.S. CLS. 19, 21, 23, 31, 35 AND 44). SN 85-228,705. PUB. 6-7-2011. FILED 1-28-2011.

4,015,805. **NVO (STANDARD CHARACTER)**. GABA, MONIBERT NARITO, DBA NVO COMPONENTS, AND GABA, DODI CECILE SHAW, DBA NVO COMPONENTS, (U.S. CLS. 19, 21, 23, 31, 35 AND 44). SN 85-229,371. PUB. 6-7-2011. FILED 1-29-2011.

4,015,806. **LOW AND MEAN (STANDARD CHARACTER)**. HAGEST, CHRIS, (U.S. CLS. 19, 21, 23, 31, 35 AND 44). SN 85-229,397. PUB. 6-7-2011. FILED 1-29-2011.

4,015,818. **BABYRULER AND DESIGN**. LONG FAITH (ZHONGSHAN) INDUSTRIAL CO., LTD., (U.S. CLS. 19, 21, 23, 31, 35 AND 44). SN 85-229,542. PUB. 6-7-2011. FILED 1-29-2011.

4,015,844. **ADVANTEK (STANDARD CHARACTER)**. DANA LIMITED, (U.S. CLS. 19, 21, 23, 31, 35 AND 44). SN 85-229,948. PUB. 6-7-2011. FILED 1-31-2011.

4,015,865. **G AND DESIGN**. ROCKY MOUNTAIN ATV, INC., (U.S. CLS. 19, 21, 23, 31, 35 AND 44). SN 85-230,353. PUB. 6-7-2011. FILED 1-31-2011.

4,015,912. **TRLAXLE (STANDARD CHARACTER)**. HENDRICKSON USA, L.L.C, (U.S. CLS. 19, 21, 23, 31, 35 AND 44). SN 85-231,009. PUB. 6-7-2011. FILED 2-1-2011.

4,015,943. **PROTECT WHAT YOU TOW! (STYLIZED)**. ROCK TAMERS, LLC, (U.S. CLS. 19, 21, 23, 31, 35 AND 44). SN 85-231,520. PUB. 6-7-2011. FILED 2-1-2011.

4,015,945. **PROTECT WHAT YOU TOW! (STANDARD CHARACTER)**. ROCK TAMERS, LLC, (U.S. CLS. 19, 21, 23, 31, 35 AND 44). SN 85-231,560. PUB. 6-7-2011. FILED 2-1-2011.

4,015,946. **FORGED TUF AND DESIGN**. ROCK TAMERS, LLC, (U.S. CLS. 19, 21, 23, 31, 35 AND 44). SN 85-231,586. PUB. 6-7-2011. FILED 2-1-2011.

4,015,947. **FORGED TUF (STANDARD CHARACTER)**. ROCK TAMERS, LLC, (U.S. CLS. 19, 21, 23, 31, 35 AND 44). SN 85-231,604. PUB. 6-7-2011. FILED 2-1-2011.

4,016,069. **CRUX (STANDARD CHARACTER)**. SPECIALIZED BICYCLE COMPONENTS, INC., (U.S. CLS. 19, 21, 23, 31, 35 AND 44). SN 85-239,143. PUB. 6-7-2011. FILED 2-10-2011.

4,016,070. **LONG HORNS (STANDARD CHARACTER)**. WOLO MANUFACTURING CORP., (U.S. CLS. 19, 21, 23, 31, 35 AND 44). SN 85-239,203. PUB. 6-7-2011. FILED 2-10-2011.

4,016,071. **CANNON BALL EXPRESS (STANDARD CHARACTER)**. WOLO MANUFACTURING CORP., (U.S. CLS. 19, 21, 23, 31, 35 AND 44). SN 85-239,251. PUB. 6-7-2011. FILED 2-10-2011.

4,016,072. **MAXI SOUND (STANDARD CHARACTER)**. WOLO MANUFACTURING CORP., (U.S. CLS. 19, 21, 23, 31, 35 AND 44). SN 85-239,270. PUB. 6-7-2011. FILED 2-10-2011.

CLASS 13—FIREARMS

4,014,268. **STAR (STANDARD CHARACTER)**. SAMSON MANUFACTURING CORP., (U.S. CLS. 2 AND 9). SN 77-566,738. PUB. 6-7-2011. FILED 9-10-2008.

4,014,352. **BLAST KNUCKLES (STANDARD CHARACTER)**. P.S. PRODUCTS, INC., (U.S. CLS. 2 AND 9). SN 77-859,575. PUB. 6-7-2011. FILED 10-28-2009.

4,014,720. **CHIAPPA FIREARMS (STANDARD CHARACTER)**. ARMI SPORT DI CHIAPPA SILVIA E C.SNC, DBA CHIAPPA FIREARMS, (U.S. CLS. 2 AND 9). SN 85-048,004. PUB. 6-7-2011. FILED 5-26-2010.

4,014,856. **WEAVER (STANDARD CHARACTER)**. ALLIANT TECHSYSTEMS INC., (U.S. CLS. 2 AND 9). SN 85-082,314. PUB. 6-7-2011. FILED 7-12-2010.

4,014,863. **WEAVER AND DESIGN**. ALLIANT TECHSYSTEMS INC., (U.S. CLS. 2 AND 9). SN 85-083,020. PUB. 6-7-2011. FILED 7-13-2010.

4,015,007. **KRAL AV (STANDARD CHARACTER)**. TUZA, YASIN, TA KRAL AV, (U.S. CLS. 2 AND 9). SN 85-121,394. PUB. 6-7-2011. FILED 9-2-2010.

4,015,437. **GUN DOCK (STYLIZED)**. GUN DOCK, LLC, (U.S. CLS. 2 AND 9). SN 85-216,160. PUB. 6-7-2011. FILED 1-12-2011.

4,015,736. **AMBUSH FIREARMS AND DESIGN**. DANIEL DEFENSE, INC., (U.S. CLS. 2 AND 9). SN 85-228,481. PUB. 6-7-2011. FILED 1-28-2011.

4,015,738. **AMBUSH FIREARMS (STANDARD CHARACTER)**. DANIEL DEFENSE, INC., (U.S. CLS. 2 AND 9). SN 85-228,494. PUB. 6-7-2011. FILED 1-28-2011.

4,015,939. **INNOVATION NOT IMITATION (STANDARD CHARACTER)**. SAFARILAND, LLC, (U.S. CLS. 2 AND 9). SN 85-231,469. PUB. 6-7-2011. FILED 2-1-2011.

CLASS 14—JEWELRY

4,014,223. **ANNIE OAKLEY (STANDARD CHARACTER)**. GABET, RENEE A, (U.S. CLS. 2, 27, 28 AND 50). SN 76-705,232. PUB. 6-7-2011. FILED 11-5-2010.

4,014,293. **NATURAL DYING (STANDARD CHARACTER)**. INSTITUTE FOR STRATEGIC CHANGE, MULTIPLE CLASS, (INT. CLS. 14 AND 16), (U.S. CLS. 2, 5, 22, 23, 27, 28, 29, 37, 38 AND 50). SN 77-673,334. PUB. 6-7-2011. FILED 2-18-2009.

4,014,391 (*See Class 9 for this trademark*).

4,014,445 (*See Class 3 for this trademark*).

4,014,455. **GULI AND DESIGN**. KARIMOVA GULNARA ISLAMOVNA, MULTIPLE CLASS, (INT. CLS. 14, 24 AND 25), (U.S. CLS. 2, 22, 27, 28, 39, 42 AND 50). SN 79-069,931. PUB. 6-7-2011. FILED 4-13-2009.

4,014,497 (*See Class 3 for this trademark*).

4,014,551. **NOBEL LEAGUE (STANDARD CHARACTER)**. LIDL STIFTUNG & CO. KG, MULTIPLE CLASS, (INT. CLS. 14, 18 AND 25), (U.S. CLS. 1, 2, 3, 22, 27, 28, 39, 41 AND 50). SN 79-086,827. PUB. 6-7-2011. FILED 7-23-2010.

4,014,565 (*See Class 10 for this trademark*).

4,014,581. **TAMBOUR SPIN TIME (STANDARD CHARACTER)**. LOUIS VUITTON MALLETIER, (U.S. CLS. 2, 27, 28 AND 50). SN 79-088,709. PUB. 6-7-2011. FILED 9-17-2010.

4,014,584. **K QUATTRO BY FFC (STYLIZED)**. F.F.C. CREATIVE GROUP S.R.L., MULTIPLE CLASS, (INT. CLS. 14, 18 AND 25), (U.S. CLS. 1, 2, 3, 22, 27, 28, 39, 41 AND 50). SN 79-088,973. PUB. 6-7-2011. FILED 9-9-2010.

4,014,599 (*See Class 9 for this trademark*).

4,014,621. **AS COLLECTION (STYLIZED)**. KABUSHIKI KAISHA J.I.F, (U.S. CLS. 2, 27, 28 AND 50). SN 79-091,156. PUB. 6-7-2011. FILED 11-22-2010.

4,014,731 (*See Class 6 for this trademark*).

4,014,745. **MISCELLANEOUS DESIGN**. WRIGHT & MCGILL CO., MULTIPLE CLASS, (INT. CLS. 14 AND 28), (U.S. CLS. 2, 22, 23, 27, 28, 38 AND 50). SN 85-056,433. PUB. 6-7-2011. FILED 6-7-2010.

4,014,879. **EARLY BIRD (STANDARD CHARACTER)**. OCEAN7 WATCH COMPANY, DBA OCEAN7 WATCH COMPANY, (U.S. CLS. 2, 27, 28 AND 50). SN 85-087,804. PUB. 6-7-2011. FILED 7-19-2010.

- 4,014,881. **CULTURENIK (STANDARD CHARACTER)**. CULTURENIK PUBLISHING, INC., (U.S. CLS. 2, 27, 28 AND 50). SN 85-088,268. PUB. 6-7-2011. FILED 7-20-2010.
- 4,014,937. **CHRISTINEDARREN JEWELRY (STYLIZED)**. CHRISTINEDARREN INC., (U.S. CLS. 2, 27, 28 AND 50). SN 85-099,258. PUB. 6-7-2011. FILED 8-3-2010.
- 4,015,070. **OR PAZ (STANDARD CHARACTER)**. QVC, INC., MULTIPLE CLASS, (INT. CLS. 14 AND 35), (U.S. CLS. 2, 27, 28, 50, 100, 101 AND 102). SN 85-139,575. PUB. 6-7-2011. FILED 9-28-2010.
- 4,015,078. **MISCELLANEOUS DESIGN**. HUNTER AND LOGAN JEWELRY LLC, (U.S. CLS. 2, 27, 28 AND 50). SN 85-141,612. PUB. 6-7-2011. FILED 9-30-2010.
- 4,015,131. **CROWN OF CREATION (STANDARD CHARACTER)**. ALBERT GAD LTD., (U.S. CLS. 2, 27, 28 AND 50). SN 85-157,735. PUB. 3-22-2011. FILED 10-21-2010.
- 4,015,150. **PITT BASKETBALL TRADITION OF EXCELLENCE AND DESIGN**. UNIVERSITY OF PITTSBURGH - OF THE COMMONWEALTH SYSTEM OF HIGHER EDUCATION, MULTIPLE CLASS, (INT. CLS. 14 AND 41), (U.S. CLS. 2, 27, 28, 50, 100, 101 AND 107). SN 85-163,719. PUB. 6-7-2011. FILED 10-28-2010.
- 4,015,165. **CRYSTAL ICING (STANDARD CHARACTER)**. CRYSTAL ICING, LLC, (U.S. CLS. 2, 27, 28 AND 50). SN 85-168,249. PUB. 6-7-2011. FILED 11-3-2010.
- 4,015,228. **THE EYES OF EVE (STANDARD CHARACTER)**. DEIRDRE KENNEDY, DBA THE EYES OF EVE, (U.S. CLS. 2, 27, 28 AND 50). SN 85-185,546. PUB. 6-7-2011. FILED 11-26-2010.
- 4,015,431. **LESLIE ZWERLING (STANDARD CHARACTER)**. ZWERLING, LESLIE, BETH, (U.S. CLS. 2, 27, 28 AND 50). SN 85-215,696. PUB. 6-7-2011. FILED 1-12-2011.
- 4,015,463. **RADIANTE MORE LOVE MORE JOY (STANDARD CHARACTER)**. SANDEEP DIAMOND CORPORATION, (U.S. CLS. 2, 27, 28 AND 50). SN 85-217,691. PUB. 6-7-2011. FILED 1-14-2011.
- 4,015,659. **UNITED STATES MINT SILVER PROOF SET (STANDARD CHARACTER)**. DEPARTMENT OF THE TREASURY, UNITED STATES MINT, (U.S. CLS. 2, 27, 28 AND 50). SN 85-224,721. PUB. 6-7-2011. FILED 1-24-2011.
- 4,015,698. **NATURALLY BRILLIANT (STANDARD CHARACTER)**. KWIAT, INC., (U.S. CLS. 2, 27, 28 AND 50). SN 85-226,722. PUB. 6-7-2011. FILED 1-26-2011.
- 4,015,730. **TYG (STANDARD CHARACTER)**. TYG DESIGNS, INC., (U.S. CLS. 2, 27, 28 AND 50). SN 85-228,139. PUB. 6-7-2011. FILED 1-27-2011.
- 4,015,745. **WEAR PEACE PROUDLY (STANDARD CHARACTER)**. ARZU, INC., (U.S. CLS. 2, 27, 28 AND 50). SN 85-228,576. PUB. 6-7-2011. FILED 1-28-2011.
- 4,015,821. **TOSHIKANE AND DESIGN**. MERCHANTTEER, INC., (U.S. CLS. 2, 27, 28 AND 50). SN 85-229,565. PUB. 6-7-2011. FILED 1-30-2011.
- 4,015,831. **A A AND DESIGN**. ALPHA SIGMA ALPHA, (U.S. CLS. 2, 27, 28 AND 50). SN 85-229,765. PUB. 6-7-2011. FILED 1-31-2011.
- 4,015,843. **NUON (STYLIZED)**. KRIPA LLC, (U.S. CLS. 2, 27, 28 AND 50). SN 85-229,923. PUB. 6-7-2011. FILED 1-31-2011.
- 4,016,002. **STELIO (STANDARD CHARACTER)**. METALLURGY, LLC, (U.S. CLS. 2, 27, 28 AND 50). SN 85-232,572. PUB. 6-7-2011. FILED 2-2-2011.
- 4,016,039. **INDUSTRIAL PACKAGE (STANDARD CHARACTER)**. DYKSTRA, TRACI, DBA INDUSTRIAL PACKAGE, (U.S. CLS. 2, 27, 28 AND 50). SN 85-233,470. PUB. 6-7-2011. FILED 2-3-2011.
- 4,016,050. **TYF (STANDARD CHARACTER)**. TYG DESIGNS, INC., (U.S. CLS. 2, 27, 28 AND 50). SN 85-233,607. PUB. 6-7-2011. FILED 2-3-2011.
- 4,016,093. **BLINGO (STANDARD CHARACTER)**. INNER CIRCLE DESIGNS, LLC, (U.S. CLS. 2, 27, 28 AND 50). SN 85-250,264. PUB. 6-7-2011. FILED 2-24-2011.
- 4,016,094. **ANI-BELLES (STANDARD CHARACTER)**. INNER CIRCLE DESIGNS, LLC, (U.S. CLS. 2, 27, 28 AND 50). SN 85-250,266. PUB. 6-7-2011. FILED 2-24-2011.

CLASS 15—MUSICAL INSTRUMENTS

- 4,015,653. **BITTERROOT GUITARS (STANDARD CHARACTER)**. HILDRETH, JOHN, (U.S. CLS. 2, 21 AND 36). SN 85-224,016. PUB. 6-7-2011. FILED 1-23-2011.

CLASS 16—PAPER GOODS AND PRINTED MATTER

- 4,014,249. **PEGASUS SCHOOL IMAGES (STANDARD CHARACTER)**. FUTURE STARS SPORTS PHOTOGRAPHY INC., MULTIPLE CLASS, (INT. CLS. 16 AND 41), (U.S. CLS. 2, 5, 22, 23, 29, 37, 38, 50, 100, 101 AND 107). SN 77-129,027. PUB. 6-7-2011. FILED 3-12-2007.
- 4,014,253 (See Class 9 for this trademark).
- 4,014,254 (See Class 9 for this trademark).
- 4,014,277. **PHUTEN (STANDARD CHARACTER)**. NINTENDO CO., LTD., (U.S. CLS. 2, 5, 22, 23, 29, 37, 38 AND 50). SN 77-601,533. PUB. 6-7-2011. FILED 10-27-2008.
- 4,014,279. **MISCELLANEOUS DESIGN**. ACH, YASMIN, MULTIPLE CLASS, (INT. CLS. 16 AND 41), (U.S. CLS. 2, 5, 22, 23, 29, 37, 38, 50, 100, 101 AND 107). SN 77-608,955. PUB. 6-7-2011. FILED 11-6-2008.
- 4,014,293 (See Class 14 for this trademark).
- 4,014,313. **CLUB 10 (STANDARD CHARACTER)**. MILES-BRAMWELL EXECUTIVE SERVICES LIMITED, MULTIPLE CLASS, (INT. CLS. 16, 41 AND 44), (U.S. CLS. 2, 5, 22, 23, 29, 37, 38, 50, 100, 101 AND 107). SN 77-753,394. PUB. 11-30-2010. FILED 6-5-2009.
- 4,014,316 (See Class 9 for this trademark).
- 4,014,317 (See Class 9 for this trademark).
- 4,014,319. **TR TODAY'S RESTAURANT AND DESIGN**. TODAY'S RESTAURANT NEWS, INC., (U.S. CLS. 2, 5, 22, 23, 29, 37, 38 AND 50). SN 77-766,882. PUB. 6-7-2011. FILED 6-24-2009.
- 4,014,327 (See Class 3 for this trademark).
- 4,014,336 (See Class 9 for this trademark).
- 4,014,337 (See Class 6 for this trademark).
- 4,014,376. **MODERN SURREALIST MARISA JAMILA PAWELKO (STANDARD CHARACTER)**. MODERN SURREALIST LLC, (U.S. CLS. 2, 5, 22, 23, 29, 37, 38 AND 50). SN 77-900,878. PUB. 6-7-2011. FILED 12-24-2009.
- 4,014,403. **BE READY (STANDARD CHARACTER)**. TAKE IT OUTSIDE HOLDINGS INC., MULTIPLE CLASS, (INT. CLS. 16, 25, 41 AND 44), (U.S. CLS. 2, 5, 22, 23, 29, 37, 38, 39, 50, 100, 101 AND 107). SN 77-938,880. PUB. 6-7-2011. FILED 2-18-2010.
- 4,014,411 (See Class 9 for this trademark).
- 4,014,428. **GONE! (STYLIZED)**. VIRANI INTERNATIONAL HOLDINGS LTD., (U.S. CLS. 2, 5, 22, 23, 29, 37, 38 AND 50). SN 77-982,301. PUB. 5-18-2010. FILED 12-7-2009.
- 4,014,430. **VIDAYSALUD (STANDARD CHARACTER)**. CULTURAL ASSET MANAGEMENT, INC., MULTIPLE CLASS, (INT. CLS. 16 AND 44), (U.S. CLS. 2, 5, 22, 23, 29, 37, 38, 50, 100 AND 101). SN 77-982,336. PUB. 5-18-2010. FILED 12-21-2009.
- 4,014,444 (See Class 9 for this trademark).
- 4,014,445 (See Class 3 for this trademark).
- 4,014,458 (See Class 9 for this trademark).
- 4,014,461 (See Class 11 for this trademark).
- 4,014,475. **MISCELLANEOUS DESIGN**. JASON ISHERWOOD, MULTIPLE CLASS, (INT. CLS. 16, 35, 36 AND 37), (U.S. CLS. 2, 5, 22, 23, 29, 37, 38, 50, 100, 101, 102, 103 AND 106). SN 79-079,007. PUB. 6-7-2011. FILED 1-15-2010.
- 4,014,481. **NATURE DECO (STYLIZED)**. PLAGÉ S.A., (U.S. CLS. 2, 5, 22, 23, 29, 37, 38 AND 50). SN 79-079,717. PUB. 6-7-2011. FILED 10-14-2009.
- 4,014,483. **FRANCO DRAGONE (STANDARD CHARACTER)**. CAPOGIRO LICENSING LIMITED LIABILITY COMPANY C/O LDA KFT, MULTIPLE CLASS, (INT. CLS. 16, 25 AND 41), (U.S. CLS. 2, 5, 22, 23, 29, 37, 38, 39, 50, 100, 101 AND 107). SN 79-079,871. PUB. 6-7-2011. FILED 11-20-2009.
- 4,014,489. **A LASER & HEALTH ACADEMY AND DESIGN**. FOTONA PROIZVODNJA OPTOELEKTRONSKIH NAPRAV D.D., MULTIPLE CLASS, (INT. CLS. 16, 35, 41, 42 AND 44), (U.S. CLS. 2, 5, 22, 23, 29, 37, 38, 50, 100, 101, 102

- AND 107). SN 79-081,221. PUB. 6-7-2011. FILED 2-17-2010.
- 4,014,503 (*See Class 9 for this trademark*).
- 4,014,506 (*See Class 1 for this trademark*).
- 4,014,510 (*See Class 9 for this trademark*).
- 4,014,518 (*See Class 12 for this trademark*).
- 4,014,555 (*See Class 1 for this trademark*).
- 4,014,599 (*See Class 9 for this trademark*).
- 4,014,710 (*See Class 9 for this trademark*).
- 4,014,711 (*See Class 9 for this trademark*).
- 4,014,731 (*See Class 6 for this trademark*).
- 4,014,759 (*See Class 2 for this trademark*).
- 4,014,777 (*See Class 9 for this trademark*).
- 4,014,778 (*See Class 9 for this trademark*).
- 4,014,788 (*See Class 9 for this trademark*).
- 4,014,804. **THINKING BIG (STANDARD CHARACTER)**. CAROLINA BIOLOGICAL SUPPLY COMPANY, MULTIPLE CLASS, (INT. CLS. 16 AND 41), (U.S. CLS. 2, 5, 22, 23, 29, 37, 38, 50, 100, 101 AND 107). SN 85-072,836. PUB. 6-7-2011. FILED 6-28-2010.
- 4,014,807. **DAUGHTRY (STANDARD CHARACTER)**. CDD HOLDING, LLC, (U.S. CLS. 2, 5, 22, 23, 29, 37, 38 AND 50). SN 85-073,534. PUB. 6-7-2011. FILED 6-29-2010.
- 4,014,827. **BEST OF WASHINGTON (STANDARD CHARACTER)**. WASHINGTON MAGAZINE, INC., (U.S. CLS. 2, 5, 22, 23, 29, 37, 38 AND 50). SN 85-076,144. PUB. 6-7-2011. FILED 7-1-2010.
- 4,014,849. **WORK 'N LIFE MATTERS (STANDARD CHARACTER)**. CEDARS-SINAI MEDICAL CENTER, MULTIPLE CLASS, (INT. CLS. 16 AND 35), (U.S. CLS. 2, 5, 22, 23, 29, 37, 38, 50, 100, 101 AND 102). SN 85-081,177. PUB. 6-7-2011. FILED 7-9-2010.
- 4,014,883. **CULTURENIK (STANDARD CHARACTER)**. CULTURENIK PUBLISHING, INC., (U.S. CLS. 2, 5, 22, 23, 29, 37, 38 AND 50). SN 85-088,773. PUB. 6-7-2011. FILED 7-20-2010.
- 4,014,919. **FARM JOURNAL LEGACY PROJECT (STYLIZED)**. FARM JOURNAL, INC., (U.S. CLS. 2, 5, 22, 23, 29, 37, 38 AND 50). SN 85-094,890. PUB. 6-7-2011. FILED 7-28-2010.
- 4,014,922. **MISCELLANEOUS DESIGN**. AMERICAN INSTITUTE FOR CANCER RESEARCH, MULTIPLE CLASS, (INT. CLS. 16, 35, 36, 41 AND 44), (U.S. CLS. 2, 5, 22, 23, 29, 37, 38, 50, 100, 101, 102 AND 107). SN 85-094,975. PUB. 6-7-2011. FILED 7-28-2010.
- 4,014,940. **MPO MEDICAL PRODUCT OUTSOURCING (STANDARD CHARACTER)**. RODMAN PUBLISHING CORP., (U.S. CLS. 2, 5, 22, 23, 29, 37, 38 AND 50). SN 85-099,624. PUB. 6-7-2011. FILED 8-4-2010.
- 4,014,974. **EMS MI RULE VISIONS THE 3D 12 LEAD ECG INFARCTION TEMPLATE AND DESIGN**. APEX INNOVATIONS INTELLECTUAL PROPERTIES, (U.S. CLS. 2, 5, 22, 23, 29, 37, 38 AND 50). SN 85-108,457. PUB. 6-7-2011. FILED 8-16-2010.
- 4,014,991. **SMILEGRAM PAPER (STANDARD CHARACTER)**. CAREY A. GRUND, (U.S. CLS. 2, 5, 22, 23, 29, 37, 38 AND 50). SN 85-118,265. PUB. 6-7-2011. FILED 8-29-2010.
- 4,015,004 (*See Class 9 for this trademark*).
- 4,015,016. **MISCELLANEOUS DESIGN**. WILSON, MORRIS JOSEPH, (U.S. CLS. 2, 5, 22, 23, 29, 37, 38 AND 50). SN 85-122,543. PUB. 6-7-2011. FILED 9-3-2010.
- 4,015,017. **MITCH SPINACH (STANDARD CHARACTER)**. MITCH SPINACH PRODUCTIONS INC., (U.S. CLS. 2, 5, 22, 23, 29, 37, 38 AND 50). SN 85-123,036. PUB. 6-7-2011. FILED 9-3-2010.
- 4,015,040. **PLAYGROUND (STANDARD CHARACTER)**. PLAYGROUND MEDIA GROUP, LLC, DBA PLAYGROUND MAGAZINE, (U.S. CLS. 2, 5, 22, 23, 29, 37, 38 AND 50). SN 85-129,104. PUB. 3-1-2011. FILED 9-14-2010.
- 4,015,045 (*See Class 9 for this trademark*).
- 4,015,071 (*See Class 9 for this trademark*).
- 4,015,080. **DESTINYQUEST (STANDARD CHARACTER)**. MICHAEL JOHN WARD, (U.S. CLS. 2, 5, 22, 23, 29, 37, 38 AND 50). SN 85-142,202. PUB. 6-7-2011. FILED 9-30-2010.
- 4,015,081 (*See Class 9 for this trademark*).
- 4,015,090. **GRENADIERS (STANDARD CHARACTER)**. THE TRUSTEES OF INDIANA UNIVERSITY, MULTIPLE CLASS, (INT. CLS. 16 AND 41), (U.S. CLS. 2, 5, 22, 23, 29, 37, 38, 50, 100, 101 AND 107). SN 85-144,052. PUB. 6-7-2011. FILED 10-4-2010.
- 4,015,153. **PRODUCED BY (STANDARD CHARACTER)**. PRODUCERS GUILD OF AMERICA, INC., MULTIPLE CLASS, (INT. CLS. 16 AND 41), (U.S. CLS. 2, 5, 22, 23, 29, 37, 38, 50, 100, 101 AND 107). SN 85-164,250. PUB. 6-7-2011. FILED 10-28-2010.
- 4,015,190 (*See Class 9 for this trademark*).
- 4,015,206. **BUSINESS WARRIOR (STANDARD CHARACTER)**. BUSINESS WARRIOR INSTITUTE, LLC, MULTIPLE CLASS, (INT. CLS. 16 AND 41), (U.S. CLS. 2, 5, 22, 23, 29, 37, 38, 50, 100, 101 AND 107). SN 85-178,802. PUB. 6-7-2011. FILED 11-17-2010.
- 4,015,243. **TUCK ME IN CARDS AND DESIGN**. SALTWATER ZAPF CO., (U.S. CLS. 2, 5, 22, 23, 29, 37, 38 AND 50). SN 85-188,819. PUB. 6-7-2011. FILED 12-1-2010.
- 4,015,296. **ABC PREPAID PHONECARD (STANDARD CHARACTER)**. UNION TELECOM, INC., (U.S. CLS. 2, 5, 22, 23, 29, 37, 38 AND 50). SN 85-199,933. PUB. 6-7-2011. FILED 12-16-2010.
- 4,015,305. **DOG HOUSE PARTIES AND DESIGN**. CATNIP TRAILS, INC., (U.S. CLS. 2, 5, 22, 23, 29, 37, 38 AND 50). SN 85-201,436. PUB. 6-7-2011. FILED 12-19-2010.
- 4,015,341. **THE WAITING GAME AND DESIGN**. ZP HOLDINGS, LLC, (U.S. CLS. 2, 5, 22, 23, 29, 37, 38 AND 50). SN 85-206,323. PUB. 6-7-2011. FILED 12-28-2010.
- 4,015,355. **CHARTBALL (STANDARD CHARACTER)**. AGP CREATIVE LLC, DBA AGP CREATIVE LLC, (U.S. CLS. 2, 5, 22, 23, 29, 37, 38 AND 50). SN 85-208,083. PUB. 6-7-2011. FILED 12-30-2010.
- 4,015,373. **QUIVER AND DESIGN**. QUIVER GLOBAL LLC, (U.S. CLS. 2, 5, 22, 23, 29, 37, 38 AND 50). SN 85-209,905. PUB. 6-7-2011. FILED 1-4-2011.
- 4,015,411. **SHOW OFF THE MAGAZINE (STANDARD CHARACTER)**. GLUMAC, DANIJEL, (U.S. CLS. 2, 5, 22, 23, 29, 37, 38 AND 50). SN 85-214,138. PUB. 6-7-2011. FILED S.R. 1-10-2011; AM. P.R. 4-5-2011.
- 4,015,488. **PINCURL GIRLS AND DESIGN**. JCL PRODUCTIONS INC., (U.S. CLS. 2, 5, 22, 23, 29, 37, 38 AND 50). SN 85-218,870. PUB. 6-7-2011. FILED 1-17-2011.
- 4,015,501. **UKC AND DESIGN**. UNITED KENNEL CLUB, INC., MULTIPLE CLASS, (INT. CLS. 16, 35 AND 41), (U.S. CLS. 2, 5, 22, 23, 29, 37, 38, 50, 100, 101, 102 AND 107). SN 85-219,371. PUB. 6-7-2011. FILED 1-17-2011.
- 4,015,522. **MYST-ART (STANDARD CHARACTER)**. MOUNTAIN QUEST INSTITUTE LLC, (U.S. CLS. 2, 5, 22, 23, 29, 37, 38 AND 50). SN 85-219,940. PUB. 6-7-2011. FILED 1-18-2011.
- 4,015,525. **SPLENDID (STANDARD CHARACTER)**. NYGALA CORP., MULTIPLE CLASS, (INT. CLS. 16, 26 AND 28), (U.S. CLS. 2, 5, 22, 23, 29, 37, 38, 39, 40, 42 AND 50). SN 85-219,990. PUB. 6-7-2011. FILED 1-18-2011.
- 4,015,566. **SOCIALVENTION (STANDARD CHARACTER)**. MORRISON, CINDY W, MULTIPLE CLASS, (INT. CLS. 16 AND 41), (U.S. CLS. 2, 5, 22, 23, 29, 37, 38, 50, 100, 101 AND 107). SN 85-221,254. PUB. 6-7-2011. FILED 1-19-2011.
- 4,015,588. **GLITTER (STANDARD CHARACTER)**. GLOBE NEW MEDIA INC., (U.S. CLS. 2, 5, 22, 23, 29, 37, 38 AND 50). SN 85-221,724. PUB. 6-7-2011. FILED 1-20-2011.
- 4,015,664 (*See Class 9 for this trademark*).
- 4,015,684. **HEYFACES (STANDARD CHARACTER)**. KOLMAN, JESSICA, DBA HEYFACES, (U.S. CLS. 2, 5, 22, 23, 29, 37, 38 AND 50). SN 85-226,028. PUB. 6-7-2011. FILED 1-25-2011.
- 4,015,692. **LIBERTY ACTION REPORT (STANDARD CHARACTER)**. LIBERTY COUNSEL, INC., AKA LIBERTY COUNCIL, (U.S. CLS. 2, 5, 22, 23, 29, 37, 38 AND 50). SN 85-226,533. PUB. 6-7-2011. FILED 1-26-2011.
- 4,015,794. **MISCELLANEOUS DESIGN**. CEDAR GROVE COMPOSTING, INC., MULTIPLE CLASS, (INT. CLS. 16, 20 AND 21), (U.S. CLS. 2, 5, 13, 22, 23, 25, 29, 30, 32, 33, 37, 38, 40 AND 50). SN 85-229,189. PUB. 6-7-2011. FILED 1-28-2011.
- 4,015,882. **R THE TURN AROUND AGENDA REBUILDING COMMUNITIES FROM THE INSIDE OUT AND DESIGN**. OAK CLIFF BIBLE FELLOWSHIP, MULTIPLE CLASS, (INT. CLS. 16, 35 AND 41), (U.S. CLS. 2, 5, 22, 23, 29, 37, 38, 50, 100, 101, 102 AND 107). SN 85-230,596. PUB. 6-7-2011. FILED 1-31-2011.
- 4,015,936. **AQUA-SOFT (STANDARD CHARACTER)**. THETFORD CORPORATION, (U.S. CLS. 2, 5, 22, 23, 29, 37, 38

AND 50). SN 85-231,288. PUB. 6-7-2011. FILED 2-1-2011.
 4,015,950. **ITSMEEE (STANDARD CHARACTER)**. PATRICIA FISHER, (U.S. CLS. 2, 5, 22, 23, 29, 37, 38 AND 50). SN 85-231,630. PUB. 6-7-2011. FILED 2-1-2011.
 4,015,987. **FINESSE (STANDARD CHARACTER)**. EVO, INC., (U.S. CLS. 2, 5, 22, 23, 29, 37, 38 AND 50). SN 85-232,402. PUB. 6-7-2011. FILED 2-2-2011.
 4,016,031. **SPECTRAMASTER (STANDARD CHARACTER)**. E. I. DU PONT DE NEMOURS AND COMPANY, (U.S. CLS. 2, 5, 22, 23, 29, 37, 38 AND 50). SN 85-233,217. PUB. 6-7-2011. FILED 2-3-2011.
 4,016,053. **WRAP WRITING ASSESSMENT PROGRAM (STYLIZED)**. EDUCATIONAL RECORDS BUREAU, MULTIPLE CLASS, (INT. CLS. 16 AND 41), (U.S. CLS. 2, 5, 22, 23, 29, 37, 38, 50, 100, 101 AND 107). SN 85-234,112. PUB. 6-7-2011. FILED 2-4-2011.
 4,016,143. **POLITICAL AMBUSH (STANDARD CHARACTER)**. BUNTON, SR., DALLAS S., MULTIPLE CLASS, (INT. CLS. 16 AND 41), (U.S. CLS. 2, 5, 22, 23, 29, 37, 38, 50, 100, 101 AND 107). SN 85-975,217. PUB. 6-7-2011. FILED 12-13-2010.

CLASS 17—RUBBER GOODS

4,014,280 (*See Class 2 for this trademark*).
 4,014,281 (*See Class 2 for this trademark*).
 4,014,461 (*See Class 11 for this trademark*).
 4,014,484 (*See Class 9 for this trademark*).
 4,014,498 (*See Class 9 for this trademark*).
 4,014,544 (*See Class 6 for this trademark*).
 4,014,555 (*See Class 1 for this trademark*).
 4,014,676 (*See Class 2 for this trademark*).
 4,014,692. **ANY SEAL ... ANY TIME (STANDARD CHARACTER)**. DICHTOMATIK AMERICAS, L.P., (U.S. CLS. 1, 5, 12, 13, 35 AND 50). SN 85-032,787. PUB. 6-7-2011. FILED 5-7-2010.
 4,014,756. **MARINEWRAP (STANDARD CHARACTER)**. ADVANCED THERMAL PRODUCTS, INC., (U.S. CLS. 1, 5, 12, 13, 35 AND 50). SN 85-061,211. PUB. 6-7-2011. FILED 6-11-2010.
 4,014,757. **ATP (STANDARD CHARACTER)**. ADVANCED THERMAL PRODUCTS, INC., (U.S. CLS. 1, 5, 12, 13, 35 AND 50). SN 85-061,239. PUB. 6-7-2011. FILED 6-11-2010.
 4,014,775. **ENERGYSEAL (STANDARD CHARACTER)**. PERMA-CHINK SYSTEMS, INC., (U.S. CLS. 1, 5, 12, 13, 35 AND 50). SN 85-065,570. PUB. 6-7-2011. FILED 6-17-2010.
 4,014,840. **HEMCRETE (STANDARD CHARACTER)**. AMERICAN LIME TECHNOLOGY, LLC, (U.S. CLS. 1, 5, 12, 13, 35 AND 50). SN 85-079,058. PUB. 6-7-2011. FILED 7-7-2010.
 4,014,912 (*See Class 6 for this trademark*).
 4,015,132. **XS SEAL (STANDARD CHARACTER)**. MARTIN FLUID POWER COMPANY, (U.S. CLS. 1, 5, 12, 13, 35 AND 50). SN 85-157,786. PUB. 6-7-2011. FILED 10-21-2010.
 4,015,823. **10X (STANDARD CHARACTER)**. 10X TECHNOLOGY LLC, FORMERLY 10X TECHNOLOGY INC, (U.S. CLS. 1, 5, 12, 13, 35 AND 50). SN 85-229,594. PUB. 6-7-2011. FILED 1-30-2011.
 4,015,842. **SERVIWRAP (STANDARD CHARACTER)**. CHASE PROTECTIVE COATINGS LIMITED, (U.S. CLS. 1, 5, 12, 13, 35 AND 50). SN 85-229,889. PUB. 6-7-2011. FILED 1-31-2011.

CLASS 18—LEATHER GOODS

4,014,199 (*See Class 3 for this trademark*).
 4,014,200 (*See Class 3 for this trademark*).
 4,014,445 (*See Class 3 for this trademark*).
 4,014,464 (*See Class 3 for this trademark*).
 4,014,470. **MYWALIT THE WALLET YOU NEVER FORGET AND DESIGN**. MYWALIT.COM S.R.L., MULTIPLE CLASS, (INT. CLS. 18, 24 AND 25), (U.S. CLS. 1, 2, 3, 22, 39, 41, 42 AND 50). SN 79-078,483. PUB. 6-7-2011. FILED 11-16-2009.
 4,014,471. **MUST (STYLIZED)**. CARTIER INTERNATIONAL AG, (U.S. CLS. 1, 2, 3, 22 AND 41). SN 79-078,643. PUB. 6-7-

2011. FILED 7-6-2009.
 4,014,497 (*See Class 3 for this trademark*).
 4,014,527. **MISCELLANEOUS DESIGN**. S. TOUS, S.L., MULTIPLE CLASS, (INT. CLS. 18 AND 25), (U.S. CLS. 1, 2, 3, 22, 39 AND 41). SN 79-085,575. PUB. 6-7-2011. FILED 6-18-2010.
 4,014,551 (*See Class 14 for this trademark*).
 4,014,584 (*See Class 14 for this trademark*).
 4,014,589. **MARWIN (STANDARD CHARACTER)**. JC AB, MULTIPLE CLASS, (INT. CLS. 18 AND 25), (U.S. CLS. 1, 2, 3, 22, 39 AND 41). SN 79-089,195. PUB. 6-7-2011. FILED 9-6-2010.
 4,014,593 (*See Class 9 for this trademark*).
 4,014,731 (*See Class 6 for this trademark*).
 4,014,803. **KING KEROSIN (STANDARD CHARACTER)**. ROSSMANN, RALF, MULTIPLE CLASS, (INT. CLS. 18 AND 25), (U.S. CLS. 1, 2, 3, 22, 39 AND 41). SN 85-072,795. PUB. 6-7-2011. FILED 6-28-2010.
 4,014,925. **PROMESSA (STANDARD CHARACTER)**. ULTRAFABRICS, LLC, MULTIPLE CLASS, (INT. CLS. 18 AND 24), (U.S. CLS. 1, 2, 3, 22, 41, 42 AND 50). SN 85-095,648. PUB. 6-7-2011. FILED 7-29-2010.
 4,015,121. **KAEMP 8848 AND DESIGN**. THAPA, PRABIN, MULTIPLE CLASS, (INT. CLS. 18, 20 AND 25), (U.S. CLS. 1, 2, 3, 13, 22, 25, 32, 39, 41 AND 50). SN 85-154,467. PUB. 6-7-2011. FILED 10-17-2010.
 4,015,169. **TAYLOR SWIFT FEARLESS (STANDARD CHARACTER)**. SWIFT, TAYLOR, (U.S. CLS. 1, 2, 3, 22 AND 41). SN 85-168,895. PUB. 6-7-2011. FILED 11-4-2010.
 4,015,190 (*See Class 9 for this trademark*).
 4,015,285. **FORE GOLF DIVAS AND DESIGN**. FORE GOLF DIVAS, INC., MULTIPLE CLASS, (INT. CLS. 18, 25 AND 28), (U.S. CLS. 1, 2, 3, 22, 23, 38, 39, 41 AND 50). SN 85-197,809. PUB. 6-7-2011. FILED 12-14-2010.
 4,015,306. **ROULIS (STANDARD CHARACTER)**. HERMES INTERNATIONAL, (U.S. CLS. 1, 2, 3, 22 AND 41). SN 85-201,524. PUB. 6-7-2011. FILED 12-20-2010.
 4,015,351. **POLITICS AND PROSE (STANDARD CHARACTER)**. POLITICS AND PROSE, INC., MULTIPLE CLASS, (INT. CLS. 18, 21, 25 AND 35), (U.S. CLS. 1, 2, 3, 13, 22, 23, 29, 30, 33, 39, 40, 41, 50, 100, 101 AND 102). SN 85-207,587. PUB. 6-7-2011. FILED 12-29-2010.
 4,015,353. **POLITICS AND PROSE BOOKSTORE COFFEEHOUSE AND DESIGN**. POLITICS AND PROSE, INC., MULTIPLE CLASS, (INT. CLS. 18, 21, 25 AND 35), (U.S. CLS. 1, 2, 3, 13, 22, 23, 29, 30, 33, 39, 40, 41, 50, 100, 101 AND 102). SN 85-207,609. PUB. 6-7-2011. FILED 12-29-2010.
 4,015,668. **SIMPLY + GREEN SOLUTIONS (STANDARD CHARACTER)**. SIMPLY GREEN SOLUTIONS INC, (U.S. CLS. 1, 2, 3, 22 AND 41). SN 85-224,951. PUB. 6-7-2011. FILED 1-24-2011.
 4,015,804. **DOUBLE DUTCH CLUB (STANDARD CHARACTER)**. OLIVET INTERNATIONAL, INC., (U.S. CLS. 1, 2, 3, 22 AND 41). SN 85-229,369. PUB. 6-7-2011. FILED 1-29-2011.
 4,015,861. **JUST A LITTLE DITTY... (STANDARD CHARACTER)**. JUST A LITTLE DITTY, LLC, (U.S. CLS. 1, 2, 3, 22 AND 41). SN 85-230,254. PUB. 6-7-2011. FILED 1-31-2011.
 4,016,056. **POETIC PAWS AND DESIGN**. CONSOLIDATED SHOE COMPANY, INC., (U.S. CLS. 1, 2, 3, 22 AND 41). SN 85-234,444. PUB. 6-7-2011. FILED 2-4-2011.

CLASS 19—NON-METALLIC BUILDING MATERIALS

4,014,387. **RAVENCRETE AND DESIGN**. COOPER SECURE TECHNOLOGIES, LLC, (U.S. CLS. 1, 12, 33 AND 50). SN 77-912,536. PUB. 6-7-2011. FILED 1-15-2010.
 4,014,388. **RAVENBOARD (STANDARD CHARACTER)**. COOPER SECURE TECHNOLOGIES, LLC, (U.S. CLS. 1, 12, 33 AND 50). SN 77-912,545. PUB. 6-7-2011. FILED 1-15-2010.
 4,014,389. **RAVENCRETE (STANDARD CHARACTER)**. COOPER SECURE TECHNOLOGIES, LLC, (U.S. CLS. 1, 12, 33 AND 50). SN 77-912,551. PUB. 6-7-2011. FILED 1-15-2010.
 4,014,467. **EDITION FLY (STANDARD CHARACTER)**. ALNO AG, MULTIPLE CLASS, (INT. CLS. 19, 20 AND 21), (U.S. CLS. 1, 2, 12, 13, 22, 23, 25, 29, 30, 32, 33, 40 AND 50). SN 79-

077,769. PUB. 6-7-2011. FILED 10-15-2009.
 4,014,472 (*See Class 11 for this trademark*).
 4,014,485 (*See Class 6 for this trademark*).
 4,014,544 (*See Class 6 for this trademark*).
 4,014,615. **LEGIOROCK (STANDARD CHARACTER)**. A. JANSSEN B.V., MULTIPLE CLASS, (INT. CLS. 19 AND 37), (U.S. CLS. 1, 12, 33, 50, 100, 103 AND 106). SN 79-090,793. PUB. 6-7-2011. FILED 8-5-2010.
 4,014,716. **WATERSHED INNOVATIONS (STANDARD CHARACTER)**. WATERSHED INNOVATIONS, DBA WATERSHED INNOVATIONS, (U.S. CLS. 1, 12, 33 AND 50). SN 85-045,407. PUB. 6-7-2011. FILED 5-21-2010.
 4,014,717. **GREEN AND REDD (STANDARD CHARACTER)**. LIGNOR LIMITED, MULTIPLE CLASS, (INT. CLS. 19 AND 31), (U.S. CLS. 1, 12, 33, 46 AND 50). SN 85-046,121. PUB. 6-7-2011. FILED 5-24-2010.
 4,015,240. **LIFECRETE (STANDARD CHARACTER)**. CPM DEVELOPMENT CORPORATION, (U.S. CLS. 1, 12, 33 AND 50). SN 85-188,492. PUB. 6-7-2011. FILED 12-1-2010.
 4,015,241. **PROS4 (STANDARD CHARACTER)**. CPM DEVELOPMENT CORPORATION, (U.S. CLS. 1, 12, 33 AND 50). SN 85-188,525. PUB. 6-7-2011. FILED 12-1-2010.
 4,015,815. **STOPPED SIGNS (STANDARD CHARACTER)**. CHARLIE NEAL, JR., DBA NEAL & COMPANY, INC., (U.S. CLS. 1, 12, 33 AND 50). SN 85-229,525. PUB. 6-7-2011. FILED 1-29-2011.
 4,015,904. **POSTSET AND DESIGN**. INTERNATIONAL CONSTRUCTION PRODUCTS RESEARCH, INC., (U.S. CLS. 1, 12, 33 AND 50). SN 85-230,909. PUB. 6-7-2011. FILED 2-1-2011.
 4,015,935. **SILTWORM (STANDARD CHARACTER)**. MOORE AND MOORE BUILDERS, INC., (U.S. CLS. 1, 12, 33 AND 50). SN 85-231,271. PUB. 6-7-2011. FILED 2-1-2011.

CLASS 20—FURNITURE AND ARTICLES NOT OTHERWISE CLASSIFIED

4,014,245 (*See Class 9 for this trademark*).
 4,014,263. **MOEDA LIVING (STANDARD CHARACTER)**. MOEDA LIVING, INC., (U.S. CLS. 2, 13, 22, 25, 32 AND 50). SN 77-520,933. PUB. 6-7-2011. FILED 7-13-2008.
 4,014,314 (*See Class 6 for this trademark*).
 4,014,332. **ECS COMPOSITES (STANDARD CHARACTER)**. ENVIRONMENTAL CONTAINER SYSTEMS, INC., DBA ECS COMPOSITES, MULTIPLE CLASS, (INT. CLS. 20, 21 AND 35), (U.S. CLS. 2, 13, 22, 23, 25, 29, 30, 32, 33, 40, 50, 100, 101 AND 102). SN 77-817,731. PUB. 6-7-2011. FILED 9-1-2009.
 4,014,391 (*See Class 9 for this trademark*).
 4,014,441. **IROCKER AND DESIGN**. ADONIS FURNITURE LLC, (U.S. CLS. 2, 13, 22, 25, 32 AND 50). SN 78-858,633. PUB. 6-7-2011. FILED 4-11-2006.
 4,014,452 (*See Class 6 for this trademark*).
 4,014,467 (*See Class 19 for this trademark*).
 4,014,468 (*See Class 4 for this trademark*).
 4,014,476 (*See Class 3 for this trademark*).
 4,014,478 (*See Class 3 for this trademark*).
 4,014,510 (*See Class 9 for this trademark*).
 4,014,564. **LX AND DESIGN**. ZHEJIANG BAIZHIJIA FURNITURE CO., LTD., (U.S. CLS. 2, 13, 22, 25, 32 AND 50). SN 79-087,357. PUB. 6-7-2011. FILED 8-17-2010.
 4,014,567. **SKEIE (STYLIZED)**. SKEIE AS, (U.S. CLS. 2, 13, 22, 25, 32 AND 50). SN 79-087,465. PUB. 6-7-2011. FILED 5-6-2010.
 4,014,667 (*See Class 12 for this trademark*).
 4,014,671. **SLEEP OPTIONS (STANDARD CHARACTER)**. CLASSIC BRANDS, LLC, (U.S. CLS. 2, 13, 22, 25, 32 AND 50). SN 85-007,503. PUB. 6-7-2011. FILED 4-6-2010.
 4,014,763. **REUNITEIT (STANDARD CHARACTER)**. LOJACK CORPORATION, MULTIPLE CLASS, (INT. CLS. 20 AND 45), (U.S. CLS. 2, 13, 22, 25, 32, 50, 100 AND 101). SN 85-063,467. PUB. 6-7-2011. FILED 6-15-2010.
 4,014,817 (*See Class 10 for this trademark*).
 4,014,850. **EDGE ALL AND DESIGN**. BRICKSTOP CORPORATION, (U.S. CLS. 2, 13, 22, 25, 32 AND 50). SN 85-081,451. PUB. 6-7-2011. FILED 7-9-2010.
 4,014,944. **ARTFUL INVENTIONS (STANDARD CHARAC-**

TER). ARTFUL INVENTIONS BY AREN IRWIN, (U.S. CLS. 2, 13, 22, 25, 32 AND 50). SN 85-100,852. PUB. 6-7-2011. FILED 8-5-2010.
 4,015,094. **I FEEL HOME (STANDARD CHARACTER)**. FREMAUX-DELORME, MULTIPLE CLASS, (INT. CLS. 20, 24 AND 25), (U.S. CLS. 2, 13, 22, 25, 32, 39, 42 AND 50). SN 85-145,903. PUB. 6-7-2011. FILED 10-6-2010.
 4,015,121 (*See Class 18 for this trademark*).
 4,015,133. **DREAMAGIC (STANDARD CHARACTER)**. FITZPATRICK, ANN T., DBA DREAMAGIC LLC, (U.S. CLS. 2, 13, 22, 25, 32 AND 50). SN 85-157,871. PUB. 6-7-2011. FILED 10-21-2010.
 4,015,136. **PAWS OF REMEMBRANCE (STANDARD CHARACTER)**. MONJELLO, DONALD, AND MONJELLO, JEFFREY, (U.S. CLS. 2, 13, 22, 25, 32 AND 50). SN 85-158,732. PUB. 6-7-2011. FILED 10-22-2010.
 4,015,332. **SIDEBLINDERS AND DESIGN**. KATHRYN C. HAIRSTON, (U.S. CLS. 2, 13, 22, 25, 32 AND 50). SN 85-204,324. PUB. 6-7-2011. FILED 12-22-2010.
 4,015,403. **HEARTCROSS (STANDARD CHARACTER)**. GREATHINGS, INC., (U.S. CLS. 2, 13, 22, 25, 32 AND 50). SN 85-213,488. PUB. 6-7-2011. FILED 1-8-2011.
 4,015,499. **DELIFRESH AND DESIGN**. INIX PRODUCTS, CORP., (U.S. CLS. 2, 13, 22, 25, 32 AND 50). SN 85-219,345. PUB. 6-7-2011. FILED 1-17-2011.
 4,015,623. **THE ZOO (STANDARD CHARACTER)**. HULTON HOUSE CORPORATION, (U.S. CLS. 2, 13, 22, 25, 32 AND 50). SN 85-222,496. PUB. 6-7-2011. FILED 1-20-2011.
 4,015,707. **X-TENDED PLAY SEATS AND DESIGN**. GARY PLATT MANUFACTURING, LLC, (U.S. CLS. 2, 13, 22, 25, 32 AND 50). SN 85-227,094. PUB. 6-7-2011. FILED 1-26-2011.
 4,015,794 (*See Class 16 for this trademark*).
 4,015,893. **RACKHEADS (STANDARD CHARACTER)**. PARAMAMIAN, JON, (U.S. CLS. 2, 13, 22, 25, 32 AND 50). SN 85-230,695. PUB. 6-7-2011. FILED 1-31-2011.
 4,015,905. **DREAM BEAMS (STANDARD CHARACTER)**. RESTONIC CORPORATION, (U.S. CLS. 2, 13, 22, 25, 32 AND 50). SN 85-230,933. PUB. 6-7-2011. FILED 2-1-2011.
 4,015,960. **KAMP-RITE (STANDARD CHARACTER)**. KAMP-RITE TENT COT INC., (U.S. CLS. 2, 13, 22, 25, 32 AND 50). SN 85-231,782. PUB. 6-7-2011. FILED 2-1-2011.

CLASS 21—HOUSEWARES AND GLASS

4,014,222. **EASYFEET AND DESIGN**. ZOOM TV PRODUCTS, LLC, (U.S. CLS. 2, 13, 23, 29, 30, 33, 40 AND 50). SN 76-705,219. PUB. 6-7-2011. FILED 11-4-2010.
 4,014,230. **FRIENDLY FACES AND DESIGN**. TAR-HONG MELAMINE USA, INC., (U.S. CLS. 2, 13, 23, 29, 30, 33, 40 AND 50). SN 76-706,184. PUB. 6-7-2011. FILED 1-31-2011.
 4,014,332 (*See Class 20 for this trademark*).
 4,014,336 (*See Class 9 for this trademark*).
 4,014,337 (*See Class 6 for this trademark*).
 4,014,467 (*See Class 19 for this trademark*).
 4,014,468 (*See Class 4 for this trademark*).
 4,014,490 (*See Class 9 for this trademark*).
 4,014,542 (*See Class 11 for this trademark*).
 4,014,556. **LUCKY-KITTY AND DESIGN**. FOUNTANA GMBH & CO. KG, (U.S. CLS. 2, 13, 23, 29, 30, 33, 40 AND 50). SN 79-087,074. PUB. 6-7-2011. FILED 4-15-2010.
 4,014,575. **MADE IN CHINA AND DESIGN**. JIANGSU YIXING FINE POTTERY CORP., LTD, (U.S. CLS. 2, 13, 23, 29, 30, 33, 40 AND 50). SN 79-088,258. PUB. 6-7-2011. FILED 6-2-2010.
 4,014,598 (*See Class 11 for this trademark*).
 4,014,600. **HOME BY ASA AND DESIGN**. ASA SELECTION GMBH, MULTIPLE CLASS, (INT. CLS. 21, 24 AND 35), (U.S. CLS. 2, 13, 23, 29, 30, 33, 40, 42, 50, 100, 101 AND 102). SN 79-089,982. PUB. 6-7-2011. FILED 8-25-2010.
 4,014,705. **BMCARE AND DESIGN**. BIOSTIME, INC. (GUANGZHOU), (U.S. CLS. 2, 13, 23, 29, 30, 33, 40 AND 50). SN 85-039,514. PUB. 3-1-2011. FILED 5-15-2010.
 4,014,731 (*See Class 6 for this trademark*).
 4,014,768. **GARDEN GENIUS (STANDARD CHARACTER)**. 3M COMPANY, (U.S. CLS. 2, 13, 23, 29, 30, 33, 40 AND 50). SN 85-064,594. PUB. 6-7-2011. FILED 6-16-2010.

- 4,014,769. **THE INTELLIGENT GARDENER (STANDARD CHARACTER)**. 3M COMPANY, (U.S. CLS. 2, 13, 23, 29, 30, 33, 40 AND 50). SN 85-064,612. PUB. 6-7-2011. FILED 6-16-2010.
- 4,014,796 (*See Class 9 for this trademark*).
- 4,014,884. **CULTURENIK (STANDARD CHARACTER)**. CULTURENIK PUBLISHING, INC., (U.S. CLS. 2, 13, 23, 29, 30, 33, 40 AND 50). SN 85-088,803. PUB. 6-7-2011. FILED 7-20-2010.
- 4,014,990. **AMERICAN PAN (STANDARD CHARACTER)**. AMERICAN PAN COMPANY, MULTIPLE CLASS, (INT. CLS. 21, 35 AND 37), (U.S. CLS. 2, 13, 23, 29, 30, 33, 40, 50, 100, 101, 102, 103 AND 106). SN 85-116,654. PUB. 6-7-2011. FILED 8-26-2010.
- 4,015,089. **ICE IN CASE OF EMERGENCY (STANDARD CHARACTER)**. STALTARI, GWEN, MULTIPLE CLASS, (INT. CLS. 21 AND 25), (U.S. CLS. 2, 13, 22, 23, 29, 30, 33, 39, 40 AND 50). SN 85-143,879. PUB. 6-7-2011. FILED 10-3-2010.
- 4,015,337. **CORONA AND DESIGN**. WATCH CLUB INC, DBA TECTRON INTERNATIONAL, (U.S. CLS. 2, 13, 23, 29, 30, 33, 40 AND 50). SN 85-205,604. PUB. 6-7-2011. FILED 12-24-2010.
- 4,015,347. **SENSORSWEEP (STANDARD CHARACTER)**. PAPPAS, PETER GREGG, (U.S. CLS. 2, 13, 23, 29, 30, 33, 40 AND 50). SN 85-207,082. PUB. 6-7-2011. FILED 12-29-2010.
- 4,015,351 (*See Class 18 for this trademark*).
- 4,015,353 (*See Class 18 for this trademark*).
- 4,015,794 (*See Class 16 for this trademark*).
- 4,015,958 (*See Class 3 for this trademark*).
- 4,015,964. **POLYWARE (STANDARD CHARACTER)**. STANDARD SALES, INC., (U.S. CLS. 2, 13, 23, 29, 30, 33, 40 AND 50). SN 85-231,846. PUB. 6-7-2011. FILED 2-1-2011.
- 4,016,011. **DIRECT TO DIRT (STANDARD CHARACTER)**. DELRAY PLANTS CO. (U.S. CLS. 2, 13, 23, 29, 30, 33, 40 AND 50). SN 85-232,701. PUB. 6-7-2011. FILED 2-2-2011.
- 4,016,021. **REECEEVAKLEENA (STANDARD CHARACTER)**. FAT COP, LLC, (U.S. CLS. 2, 13, 23, 29, 30, 33, 40 AND 50). SN 85-232,901. PUB. 6-7-2011. FILED 2-3-2011.
- 4,016,057. **SERVALIER (STANDARD CHARACTER)**. DART INDUSTRIES INC., (U.S. CLS. 2, 13, 23, 29, 30, 33, 40 AND 50). SN 85-234,513. PUB. 6-7-2011. FILED 2-4-2011.
- 4,016,081. **BETTASCENE (STANDARD CHARACTER)**. KOLLER ENTERPRISES, INC., DBA HAWKEYE INTERNATIONAL, (U.S. CLS. 2, 13, 23, 29, 30, 33, 40 AND 50). SN 85-243,106. PUB. 6-7-2011. FILED 2-15-2011.

CLASS 22—CORDAGE AND FIBERS

- 4,014,456. **MISCELLANEOUS DESIGN**. HUAMAO (XIAMEN) WEAVING; DYEING & FINISHING CO., LTD., MULTIPLE CLASS, (INT. CLS. 22 AND 24), (U.S. CLS. 1, 2, 7, 19, 22, 42 AND 50). SN 79-070,459. PUB. 6-7-2011. FILED 3-10-2009.
- 4,014,468 (*See Class 4 for this trademark*).
- 4,015,578. **INSUL-BRIGHT (STANDARD CHARACTER)**. CHUMBLEY, JAMES, F., (U.S. CLS. 1, 2, 7, 19, 22, 42 AND 50). SN 85-221,515. PUB. 6-7-2011. FILED 1-19-2011.

CLASS 24—FABRICS

- 4,014,211. **DAVID TEXTILES, INC. (STANDARD CHARACTER)**. DAVID TEXTILES, INC., (U.S. CLS. 42 AND 50). SN 76-703,210. PUB. 6-7-2011. FILED 6-1-2010.
- 4,014,420. **GYM TANNING LAUNDRY (STANDARD CHARACTER)**. VIACOM INTERNATIONAL INC., (U.S. CLS. 42 AND 50). SN 77-960,149. PUB. 3-1-2011. FILED 3-16-2010.
- 4,014,455 (*See Class 14 for this trademark*).
- 4,014,456 (*See Class 22 for this trademark*).
- 4,014,464 (*See Class 3 for this trademark*).
- 4,014,468 (*See Class 4 for this trademark*).
- 4,014,470 (*See Class 18 for this trademark*).
- 4,014,484 (*See Class 9 for this trademark*).
- 4,014,594. **LAUGH, GIGGLE, AND SMILE (STANDARD CHARACTER)**. YEELEIN TEXTILE CO., LTD., MULTIPLE

- CLASS, (INT. CLS. 24, 25 AND 28), (U.S. CLS. 22, 23, 38, 39, 42 AND 50). SN 79-089,706. PUB. 6-7-2011. FILED 10-28-2010.
- 4,014,600 (*See Class 21 for this trademark*).
- 4,014,696. **ROCK BOYS (STANDARD CHARACTER)**. BARTO, ROBERT, DBA ROCK BOYS, (U.S. CLS. 42 AND 50). SN 85-035,031. PUB. 6-7-2011. FILED 5-11-2010.
- 4,014,719. **MALOUF FINE LINENS (STANDARD CHARACTER)**. MALOUF MARKETING, INC., DBA MALOUF FINE LINENS, (U.S. CLS. 42 AND 50). SN 85-047,846. PUB. 6-7-2011. FILED 5-26-2010.
- 4,014,731 (*See Class 6 for this trademark*).
- 4,014,759 (*See Class 2 for this trademark*).
- 4,014,800. **STOPLITE (STANDARD CHARACTER)**. VALLEY FORGE FABRICS INC, (U.S. CLS. 42 AND 50). SN 85-071,289. PUB. 6-7-2011. FILED 6-24-2010.
- 4,014,925 (*See Class 18 for this trademark*).
- 4,015,094 (*See Class 20 for this trademark*).
- 4,015,246 (*See Class 7 for this trademark*).
- 4,016,103. **PM BY DOWNRIGHT AND DESIGN**. DOWNRIGHT LTD., (U.S. CLS. 42 AND 50). SN 85-253,543. PUB. 7-19-2011. FILED 2-28-2011.

CLASS 25—CLOTHING

- 4,014,201. **PINK PUNCH (STANDARD CHARACTER)**. BMGM CO., L.L.C., (U.S. CLS. 22 AND 39). SN 76-639,445. PUB. 6-7-2011. FILED 5-25-2005.
- 4,014,203. **MISCELLANEOUS DESIGN**. HINES, ANTHONY, (U.S. CLS. 22 AND 39). SN 76-698,865. PUB. 6-7-2011. FILED 2-17-2011.
- 4,014,208. **CARIBBEAN CASUALS AND DESIGN**. BAY ISLAND SPORTSWEAR, (U.S. CLS. 22 AND 39). SN 76-702,817. PUB. 6-7-2011. FILED 5-5-2010.
- 4,014,218. **MISCELLANEOUS DESIGN**. DIVAS GONE WILD DESIGNS AND MORE, INC, (U.S. CLS. 22 AND 39). SN 76-704,023. PUB. 6-7-2011. FILED 8-5-2010.
- 4,014,238. **WAYSEEKER (STANDARD CHARACTER)**. WILKINS, EARL S., (U.S. CLS. 22 AND 39). SN 76-706,239. PUB. 6-7-2011. FILED 2-1-2011.
- 4,014,253 (*See Class 9 for this trademark*).
- 4,014,254 (*See Class 9 for this trademark*).
- 4,014,261. **HOT ROD HERITAGE (STANDARD CHARACTER)**. NATIONAL HOT ROD ASSOCIATION, DBA NHRA, (U.S. CLS. 22 AND 39). SN 77-479,996. PUB. 6-7-2011. FILED 5-21-2008.
- 4,014,265. **CHRISTENSON SURFBOARDS (STANDARD CHARACTER)**. CHRISTENSON, CHRIS, (U.S. CLS. 22 AND 39). SN 77-562,204. PUB. 8-18-2009. FILED 9-4-2008.
- 4,014,272. **EVERYBODY MEASURES UP (STANDARD CHARACTER)**. DAVIS, KEITH, (U.S. CLS. 22 AND 39). SN 77-591,841. PUB. 6-7-2011. FILED 10-13-2008.
- 4,014,276. **PHUTEN (STANDARD CHARACTER)**. NINTENDO CO., LTD., (U.S. CLS. 22 AND 39). SN 77-601,524. PUB. 6-7-2011. FILED 10-27-2008.
- 4,014,336 (*See Class 9 for this trademark*).
- 4,014,337 (*See Class 6 for this trademark*).
- 4,014,341. **NEWKON (STANDARD CHARACTER)**. NEWKON, LLC, (U.S. CLS. 22 AND 39). SN 77-844,805. PUB. 6-7-2011. FILED 10-8-2009.
- 4,014,366. **MARSHALL FAULK FOUNDATION 28 AND DESIGN**. MARSHALL FAULK FOUNDATION, MULTIPLE CLASS, (INT. CLS. 25 AND 28), (U.S. CLS. 22, 23, 38, 39 AND 50). SN 77-890,753. PUB. 6-7-2011. FILED 12-10-2009.
- 4,014,371. **COYLE'S (STANDARD CHARACTER)**. COYLE, TODD, (U.S. CLS. 22 AND 39). SN 77-891,729. PUB. 6-7-2011. FILED 12-11-2009.
- 4,014,372. **ILILANGA AND DESIGN**. HARDY DEBBIE MARTINE, (U.S. CLS. 22 AND 39). SN 77-892,370. PUB. 6-7-2011. FILED 12-14-2009.
- 4,014,403 (*See Class 16 for this trademark*).
- 4,014,404. **BIG SHOW (STANDARD CHARACTER)**. WORLD WRESTLING ENTERTAINMENT, INC., (U.S. CLS. 22 AND 39). SN 77-940,860. PUB. 1-4-2011. FILED 2-21-2010.
- 4,014,412. **COME FLY WITH ME (STANDARD CHARACTER)**. TOP GUN INTELLECTUAL PROPERTIES, LLC, (U.S. CLS. 22 AND 39). SN 77-951,124. PUB. 6-7-2011. FILED 3-4-2010.

- 4,014,424 (*See Class 10 for this trademark*).
- 4,014,440. **BLUE LOOP (STANDARD CHARACTER)**. WINGS MANUFACTURING CORPORATION, (U.S. CLS. 22 AND 39). SN 78-785,443. PUB. 5-5-2009. FILED 1-5-2006.
- 4,014,445 (*See Class 3 for this trademark*).
- 4,014,454. **SOLESTAR (STANDARD CHARACTER)**. LIFE GEAR CORPORATION, (U.S. CLS. 22 AND 39). SN 79-068,641. PUB. 6-7-2011. FILED 4-1-2009.
- 4,014,455 (*See Class 14 for this trademark*).
- 4,014,468 (*See Class 4 for this trademark*).
- 4,014,470 (*See Class 18 for this trademark*).
- 4,014,483 (*See Class 16 for this trademark*).
- 4,014,495 (*See Class 9 for this trademark*).
- 4,014,497 (*See Class 3 for this trademark*).
- 4,014,510 (*See Class 9 for this trademark*).
- 4,014,518 (*See Class 12 for this trademark*).
- 4,014,527 (*See Class 18 for this trademark*).
- 4,014,533. **GA'SANIA (STYLIZED)**. WANG LIZHONG, MULTIPLE CLASS, (INT. CLS. 25 AND 35), (U.S. CLS. 22, 39, 100, 101 AND 102). SN 79-085,751. PUB. 6-7-2011. FILED 4-12-2010.
- 4,014,545 (*See Class 12 for this trademark*).
- 4,014,546. **CHOCOLATE SCHUBAR (STANDARD CHARACTER)**. ALPHA SKY ASSOCIATES LTD, (U.S. CLS. 22 AND 39). SN 79-086,689. PUB. 6-7-2011. FILED 6-1-2010.
- 4,014,551 (*See Class 14 for this trademark*).
- 4,014,552. **HEADSOX FLEXIBLE HEADWEAR (STYLIZED)**. MAP CREATIVE PTY LTD, (U.S. CLS. 22 AND 39). SN 79-086,871. PUB. 6-7-2011. FILED 8-24-2010.
- 4,014,558. **ALBANO (STYLIZED)**. GISER S.R.L., (U.S. CLS. 22 AND 39). SN 79-087,169. PUB. 6-7-2011. FILED 6-9-2010.
- 4,014,583 (*See Class 9 for this trademark*).
- 4,014,584 (*See Class 14 for this trademark*).
- 4,014,589 (*See Class 18 for this trademark*).
- 4,014,593 (*See Class 9 for this trademark*).
- 4,014,594 (*See Class 24 for this trademark*).
- 4,014,598 (*See Class 11 for this trademark*).
- 4,014,599 (*See Class 9 for this trademark*).
- 4,014,605. **GOLF STREET (STANDARD CHARACTER)**. ECCO SKO A/S, (U.S. CLS. 22 AND 39). SN 79-090,341. PUB. 6-7-2011. FILED 11-12-2010.
- 4,014,618. **NEW NEGRO AND DESIGN**. JORDI GAINZA DEL RIO, (U.S. CLS. 22 AND 39). SN 79-091,140. PUB. 6-7-2011. FILED 11-8-2010.
- 4,014,624. **EMBRACE (STYLIZED)**. REENAGH MCCALL, (U.S. CLS. 22 AND 39). SN 79-091,386. PUB. 6-7-2011. FILED 11-8-2010.
- 4,014,634. **WORLD CTU WORLD CHILDREN TAEKWONDO UNION AND DESIGN**. PARK VERLAG GMBH, MULTIPLE CLASS, (INT. CLS. 25, 28 AND 41), (U.S. CLS. 22, 23, 38, 39, 50, 100, 101 AND 107). SN 79-092,443. PUB. 6-7-2011. FILED 11-30-2010.
- 4,014,642. **U- D - L AND DESIGN**. U DAN-LING, GUANGZHOU GARMENT CO., LTD, (U.S. CLS. 22 AND 39). SN 79-093,187. PUB. 6-7-2011. FILED 1-21-2011.
- 4,014,678. **SWAY (STANDARD CHARACTER)**. YOUR SLIP IS SHOWING LLC, DBA YOUR SLIP IS SHOWING, (U.S. CLS. 22 AND 39). SN 85-017,778. PUB. 6-7-2011. FILED 4-19-2010.
- 4,014,722. **HONEY BUNNY BABY (STANDARD CHARACTER)**. PAMELA PIERNE, DBA HONEY BUNNY BABY, (U.S. CLS. 22 AND 39). SN 85-048,658. PUB. 6-7-2011. FILED 5-26-2010.
- 4,014,731 (*See Class 6 for this trademark*).
- 4,014,751. **VENUS (STANDARD CHARACTER)**. VENUS FASHION, INC., (U.S. CLS. 22 AND 39). SN 85-059,231. PUB. 6-7-2011. FILED 6-10-2010.
- 4,014,753. **CHAIRMAN MEOW (STANDARD CHARACTER)**. CHAO, WENDY, (U.S. CLS. 22 AND 39). SN 85-060,021. PUB. 6-7-2011. FILED 6-10-2010.
- 4,014,767. **FLIRTATIOUS (STANDARD CHARACTER)**. NEW HAMPTON CREATIONS, INC., (U.S. CLS. 22 AND 39). SN 85-064,376. PUB. 6-7-2011. FILED 6-16-2010.
- 4,014,803 (*See Class 18 for this trademark*).
- 4,014,808. **DAUGHTRY (STANDARD CHARACTER)**. CDD HOLDING, LLC, (U.S. CLS. 22 AND 39). SN 85-073,541. PUB. 6-7-2011. FILED 6-29-2010.
- 4,014,809. **OLIVIA RUBIN (STANDARD CHARACTER)**. RUBIN, OLIVIA, AND RUBIN, DANIEL, (U.S. CLS. 22 AND 39). SN 85-073,940. PUB. 6-7-2011. FILED 6-29-2010.
- 4,014,819. **OF RAGS (STANDARD CHARACTER)**. OF RAGS CLOTHING LLC, (U.S. CLS. 22 AND 39). SN 85-075,542. PUB. 6-7-2011. FILED 6-30-2010.
- 4,014,836. **HEAVENLY SOUND RECORDS (STANDARD CHARACTER)**. MASON, CHENG, MULTIPLE CLASS, (INT. CLS. 25 AND 41), (U.S. CLS. 22, 39, 100, 101 AND 107). SN 85-078,081. PUB. 6-7-2011. FILED 7-6-2010.
- 4,014,843. **MY RIGHT AND DESIGN**. JAMES H. WATERS III, (U.S. CLS. 22 AND 39). SN 85-079,563. PUB. 6-7-2011. FILED 7-7-2010.
- 4,014,855. **HIDE-A-PAIR SCARVES (STANDARD CHARACTER)**. NASTASI, KATHLEEN T., (U.S. CLS. 22 AND 39). SN 85-082,083. PUB. 6-7-2011. FILED 7-11-2010.
- 4,014,858. **NOMO (STANDARD CHARACTER)**. FIVE BAMBOO LLC, (U.S. CLS. 22 AND 39). SN 85-082,749. PUB. 6-7-2011. FILED 7-12-2010.
- 4,014,860. **XCLUSIVE RYDERS 5 6 7 8 9 10 AND DESIGN**. MOLLISON, MATHEW B, DBA XCLUSIVE RYDERS, (U.S. CLS. 22 AND 39). SN 85-082,913. PUB. 6-7-2011. FILED 7-12-2010.
- 4,014,861. **DETROIT DERBY GIRLS (STANDARD CHARACTER)**. DETROIT DERBY GIRLS 2007 LLC, MULTIPLE CLASS, (INT. CLS. 25 AND 41), (U.S. CLS. 22, 39, 100, 101 AND 107). SN 85-082,926. PUB. 6-7-2011. FILED 7-12-2010.
- 4,014,870. **WORK AND DESIGN**. WORK LABS, LLC, (U.S. CLS. 22 AND 39). SN 85-085,713. PUB. 6-7-2011. FILED 7-15-2010.
- 4,014,906. **H AND DESIGN**. HURLEY INTERNATIONAL LLC, (U.S. CLS. 22 AND 39). SN 85-093,023. PUB. 6-7-2011. FILED 7-26-2010.
- 4,014,941. **ETHNIQE (STYLIZED)**. ETHNIQE INC., (U.S. CLS. 22 AND 39). SN 85-100,416. PUB. 6-7-2011. FILED 8-4-2010.
- 4,014,951. **LE MARCHAND D'ETOILES (STANDARD CHARACTER)**. MARCHAND D'ETOILES, (U.S. CLS. 22 AND 39). SN 85-103,108. PUB. 6-7-2011. FILED 8-9-2010.
- 4,014,958. **KARAKO (STANDARD CHARACTER)**. KARAKO SUITS LTD., MULTIPLE CLASS, (INT. CLS. 25 AND 35), (U.S. CLS. 22, 39, 100, 101 AND 102). SN 85-104,200. PUB. 6-7-2011. FILED 8-10-2010.
- 4,014,961. **CHARMANTE (STYLIZED)**. CHARMANTE BODY FASHIONS LIMITED, (U.S. CLS. 22 AND 39). SN 85-104,897. PUB. 6-7-2011. FILED 8-11-2010.
- 4,014,970. **POWER OF QUIET (STANDARD CHARACTER)**. TOLEJKO, PAUL, (U.S. CLS. 22 AND 39). SN 85-107,036. PUB. 6-7-2011. FILED 8-13-2010.
- 4,014,978. **PHILOSOPHY (STANDARD CHARACTER)**. PHILOSOPHY, INC., (U.S. CLS. 22 AND 39). SN 85-110,579. PUB. 6-7-2011. FILED 8-18-2010.
- 4,014,997. **OISHI-M (STYLIZED)**. IAN GLADSTONE MCPHERSON PTY LTD, (U.S. CLS. 22 AND 39). SN 85-120,346. PUB. 6-7-2011. FILED 8-31-2010.
- 4,015,021. **RR AND DESIGN**. RICA APPAREL LLC, (U.S. CLS. 22 AND 39). SN 85-123,687. PUB. 6-7-2011. FILED 9-7-2010.
- 4,015,037. **PLAY NICE. MAKE FRIENDS. SHARE TOYS. (STANDARD CHARACTER)**. HAMILTON, DEBRA A, DBA WORKING LIKE A DOG, (U.S. CLS. 22 AND 39). SN 85-128,917. PUB. 6-7-2011. FILED 9-14-2010.
- 4,015,077. **NEUW (STANDARD CHARACTER)**. THREE-BYONE PTY LIMITED, (U.S. CLS. 22 AND 39). SN 85-141,551. PUB. 6-7-2011. FILED 9-29-2010.
- 4,015,089 (*See Class 21 for this trademark*).
- 4,015,094 (*See Class 20 for this trademark*).
- 4,015,121 (*See Class 18 for this trademark*).
- 4,015,164. **DAN AND DESIGN**. ASHANTI NICHOLE HAMILTON, DBA DEZTINNI BY ASHANTI-NICHOLE, (U.S. CLS. 22 AND 39). SN 85-167,511. PUB. 6-7-2011. FILED 11-2-2010.
- 4,015,184. **LOLA CRUZ (STANDARD CHARACTER)**. NAVIMA CALZADOS, S.L., (U.S. CLS. 22 AND 39). SN 85-173,888. PUB. 6-7-2011. FILED 11-10-2010.
- 4,015,186. **ANCHORED STYLE AND DESIGN**. LAUREN SIKTBERG, DBA ANCHORED STYLE, (U.S. CLS. 22 AND 39). SN 85-174,706. PUB. 6-7-2011. FILED 11-11-2010.
- 4,015,226. **IRUN ATHLETIC WEAR AND DESIGN**. POTOS, PETE, (U.S. CLS. 22 AND 39). SN 85-184,984. PUB. 6-7-2011. FILED 11-24-2010.
- 4,015,251. **E AND DESIGN**. EMPOWERED CLOTHING COM-

- PANY, LLC, (U.S. CLS. 22 AND 39). SN 85-192,376. PUB. 6-7-2011. FILED 12-7-2010.
- 4,015,281. **THUMBDOGS (STANDARD CHARACTER)**. KLAUSNER, MICHAEL, (U.S. CLS. 22 AND 39). SN 85-197,336. PUB. 6-7-2011. FILED 12-14-2010.
- 4,015,284. **INSHORE ANGLER LIGHT TACKLE FISHING AND DESIGN**. INSHORE ANGLER CHARTERS, INC., DBA INSHORE ANGLER, (U.S. CLS. 22 AND 39). SN 85-197,501. PUB. 6-7-2011. FILED 12-14-2010.
- 4,015,285 (*See Class 18 for this trademark*).
- 4,015,315. **SALTY DUDE SUN SAND SURF N SALT AND DESIGN**. CAMPISI, RICHARD M, DBA SALTY DUDE, (U.S. CLS. 22 AND 39). SN 85-202,374. PUB. 6-7-2011. FILED 12-21-2010.
- 4,015,346 (*See Class 7 for this trademark*).
- 4,015,351 (*See Class 18 for this trademark*).
- 4,015,353 (*See Class 18 for this trademark*).
- 4,015,360. **4 LACES (STYLIZED)**. 4 LACES, LLC, (U.S. CLS. 22 AND 39). SN 85-208,889. PUB. 6-7-2011. FILED 1-2-2011.
- 4,015,386. **CHANGES THINGS AND DESIGN**. BLOCKER, DEMETRIUS L, DBA LOVECHANGETHINGS.COM, (U.S. CLS. 22 AND 39). SN 85-211,638. PUB. 6-7-2011. FILED 1-6-2011.
- 4,015,404. **TWO WHEEL MAFIA AND DESIGN**. TWO WHEEL MAFIA, LLC, MULTIPLE CLASS, (INT. CLS. 25 AND 40), (U.S. CLS. 22, 39, 100, 103 AND 106). SN 85-213,502. PUB. 6-7-2011. FILED 1-8-2011.
- 4,015,424. **THE BEAR WHISPERER AND DESIGN**. SEARLES, STEVEN B., DBA THE BEAR WHISPERER, (U.S. CLS. 22 AND 39). SN 85-214,849. PUB. 6-7-2011. FILED 1-11-2011.
- 4,015,439. **LOLA INTIMATES AND DESIGN**. ESCANTE, INC., (U.S. CLS. 22 AND 39). SN 85-216,199. PUB. 6-7-2011. FILED 1-12-2011.
- 4,015,447. **UNITED REVOLUTION U R ROCK'N THE WORLD FOR CHANGE AND DESIGN**. BROCK, NATHANIEL, (U.S. CLS. 22 AND 39). SN 85-216,905. PUB. 6-7-2011. FILED 1-13-2011.
- 4,015,516. **V VOLER AND DESIGN**. DEYO, INC., (U.S. CLS. 22 AND 39). SN 85-219,726. PUB. 6-7-2011. FILED 1-18-2011.
- 4,015,524. **PLAYFUL PASTIES (STANDARD CHARACTER)**. DRYPLEX INC, (U.S. CLS. 22 AND 39). SN 85-219,953. PUB. 6-7-2011. FILED 1-18-2011.
- 4,015,547. **BLUE HAWAII LIFESTYLE (STANDARD CHARACTER)**. BLUE HAWAII LIFESTYLE, LLC, MULTIPLE CLASS, (INT. CLS. 25, 35 AND 43), (U.S. CLS. 22, 39, 100, 101 AND 102). SN 85-220,862. PUB. 6-7-2011. FILED 1-19-2011.
- 4,015,548. **SECKENCE AND DESIGN**. SECKENCE INC, (U.S. CLS. 22 AND 39). SN 85-220,896. PUB. 6-7-2011. FILED 1-19-2011.
- 4,015,552. **CIRCLE OF SUCCESS (STYLIZED)**. COS INC., (U.S. CLS. 22 AND 39). SN 85-220,950. PUB. 6-7-2011. FILED 1-19-2011.
- 4,015,580. **DOUBLE DUTCH CLUB (STANDARD CHARACTER)**. OLIVET INTERNATIONAL, INC., (U.S. CLS. 22 AND 39). SN 85-221,553. PUB. 6-7-2011. FILED 1-19-2011.
- 4,015,607. **HOT STRAPS (STANDARD CHARACTER)**. JANN LORI, LLC, (U.S. CLS. 22 AND 39). SN 85-222,091. PUB. 6-7-2011. FILED 1-20-2011.
- 4,015,626. **CHIX SPORT AND DESIGN**. INDELIBLE MARKS, LLC, (U.S. CLS. 22 AND 39). SN 85-222,554. PUB. 6-7-2011. FILED 1-20-2011.
- 4,015,643. **DESTINATION? JOYFUL! (STANDARD CHARACTER)**. KIMBERLY LEPINS, DBA CHICKLIT POWER MINISTRIES, MULTIPLE CLASS, (INT. CLS. 25 AND 41), (U.S. CLS. 22, 39, 100, 101 AND 107). SN 85-223,222. PUB. 6-7-2011. FILED 1-21-2011.
- 4,015,645. **B BADGER SPORT AND DESIGN**. BADGER SPORSTWEAR, (U.S. CLS. 22 AND 39). SN 85-223,284. PUB. 6-7-2011. FILED 1-21-2011.
- 4,015,655. **MISCELLANEOUS DESIGN**. THE CURATORS OF THE UNIVERSITY OF MISSOURI, MULTIPLE CLASS, (INT. CLS. 25 AND 41), (U.S. CLS. 22, 39, 100, 101 AND 107). SN 85-224,292. PUB. 6-7-2011. FILED 1-24-2011.
- 4,015,656. **MISCELLANEOUS DESIGN**. THE CURATORS OF THE UNIVERSITY OF MISSOURI, MULTIPLE CLASS, (INT. CLS. 25 AND 41), (U.S. CLS. 22, 39, 100, 101 AND 107). SN 85-224,359. PUB. 6-7-2011. FILED 1-24-2011.
- 4,015,690. **BUCKSKIN ARMOR, LLC "BRING OUT YOUR PRIMAL INSTINCTS" AND DESIGN**. BUCKSKIN ARMOR LLC, (U.S. CLS. 22 AND 39). SN 85-226,421. PUB. 6-7-2011. FILED 1-26-2011.
- 4,015,723. **GENUINE FIGHTWEAR M KIMONOS TRADE-MARK SINCE 1995 AND DESIGN**. LUCIANA MACHADO SIMON, AND JOSH SIMON, (U.S. CLS. 22 AND 39). SN 85-227,840. PUB. 6-7-2011. FILED 1-27-2011.
- 4,015,729. **DRESSED'N-CASE (STANDARD CHARACTER)**. ROSADIUK, KIMBERLY N, AKA MORSE CODE DE-ZYNZ LTD., (U.S. CLS. 22 AND 39). SN 85-228,003. PUB. 6-7-2011. FILED 1-27-2011.
- 4,015,732. **GET LIFTED (STANDARD CHARACTER)**. MARTIN, RUSSELL, (U.S. CLS. 22 AND 39). SN 85-228,395. PUB. 6-7-2011. FILED 1-28-2011.
- 4,015,751. **QUELL YOUR CELL AND DESIGN**. DAY, JOHN, (U.S. CLS. 22 AND 39). SN 85-228,689. PUB. 6-7-2011. FILED 1-28-2011.
- 4,015,758. **CHIP LEADER (STANDARD CHARACTER)**. JAMES, JELANI, (U.S. CLS. 22 AND 39). SN 85-228,769. PUB. 6-7-2011. FILED 1-28-2011.
- 4,015,765. **BOOBIES MAKE ME SMILE (STANDARD CHARACTER)**. SPENCER GIFTS LLC, (U.S. CLS. 22 AND 39). SN 85-228,816. PUB. 6-7-2011. FILED 1-28-2011.
- 4,015,767. **VINTAGE TROUBLE VT AND DESIGN**. SHARK EATING DOG, LLC, DBA VINTAGE TROUBLE, (U.S. CLS. 22 AND 39). SN 85-228,867. PUB. 6-7-2011. FILED 1-28-2011.
- 4,015,768. **A A AND DESIGN**. ALPHA SIGMA ALPHA, (U.S. CLS. 22 AND 39). SN 85-228,884. PUB. 6-7-2011. FILED 1-28-2011.
- 4,015,803. **AMERICAN ALWAYS (STANDARD CHARACTER)**. CHAVEZ, EDGAR MATANGUIHAN, DBA GOT CRUISER?, (U.S. CLS. 22 AND 39). SN 85-229,347. PUB. 6-7-2011. FILED 1-28-2011.
- 4,015,811. **TONY LAMA (STANDARD CHARACTER)**. BOOT ROYALTY COMPANY, L.P., (U.S. CLS. 22 AND 39). SN 85-229,450. PUB. 6-7-2011. FILED 1-29-2011.
- 4,015,827. **STUZIO (STANDARD CHARACTER)**. CHOI, BRIAN J, DBA STUZIO, (U.S. CLS. 22 AND 39). SN 85-229,655. PUB. 6-7-2011. FILED 1-30-2011.
- 4,015,840. **POWER & WEALTH P W AND DESIGN**. GIPSON, LANCE, AND INGRAM, EVAN, AND BROWN, DEREK, (U.S. CLS. 22 AND 39). SN 85-229,878. PUB. 6-7-2011. FILED 1-31-2011.
- 4,015,847. **HH AND DESIGN**. SHUSTA, PERRY, (U.S. CLS. 22 AND 39). SN 85-229,982. PUB. 6-7-2011. FILED 1-31-2011.
- 4,015,855. **SOFT ONES (STANDARD CHARACTER)**. RELIABLE KNITTING WORKS, INC., DBA RELIABLE OF MILWAUKEE, (U.S. CLS. 22 AND 39). SN 85-230,100. PUB. 6-7-2011. FILED 1-31-2011.
- 4,015,892. **M-YOU (STANDARD CHARACTER)**. FENGLIDA TRADING INC., (U.S. CLS. 22 AND 39). SN 85-230,687. PUB. 6-7-2011. FILED 1-31-2011.
- 4,015,920. **MISCELLANEOUS DESIGN**. CROWDRISE, LLC, MULTIPLE CLASS, (INT. CLS. 25 AND 35), (U.S. CLS. 22, 39, 100, 101 AND 102). SN 85-231,127. PUB. 6-7-2011. FILED 2-1-2011.
- 4,015,924. **SNIRT RUN (STANDARD CHARACTER)**. BARNES CORNERS SNO-PALS INC., MULTIPLE CLASS, (INT. CLS. 25 AND 41), (U.S. CLS. 22, 39, 100, 101 AND 107). SN 85-231,171. PUB. 6-7-2011. FILED 2-1-2011.
- 4,015,930. **HIP-LIFE (STANDARD CHARACTER)**. HIP-LIFE, (U.S. CLS. 22 AND 39). SN 85-231,216. PUB. 6-7-2011. FILED 2-1-2011.
- 4,015,933. **SWICHAROOS AND DESIGN**. SWICHAROOS INC, (U.S. CLS. 22 AND 39). SN 85-231,254. PUB. 6-7-2011. FILED 2-1-2011.
- 4,015,952. **PURITY AND PROSPERITY (STANDARD CHARACTER)**. JOHN PRYOR, (U.S. CLS. 22 AND 39). SN 85-231,650. PUB. 6-7-2011. FILED 2-1-2011.
- 4,015,969. **CLOUD9WORLD AND DESIGN**. CLOUD 9 WORLD CORP., (U.S. CLS. 22 AND 39). SN 85-231,980. PUB. 6-7-2011. FILED 2-2-2011.
- 4,015,981. **SENSHI (STANDARD CHARACTER)**. THOMAS M. O'RIORDAN, (U.S. CLS. 22 AND 39). SN 85-232,355. PUB. 6-7-2011. FILED 2-2-2011.
- 4,015,992. **RUN CIRCLES (STANDARD CHARACTER)**. THOMAS M. O'RIORDAN, (U.S. CLS. 22 AND 39). SN 85-232,440. PUB. 6-7-2011. FILED 2-2-2011.

- 4,015,994. **MY SWAG IS (STANDARD CHARACTER)**. SWAG4LIFE LLC, (U.S. CLS. 22 AND 39). SN 85-232,444. PUB. 6-7-2011. FILED 2-2-2011.
- 4,016,013. **LITTLE TRENDSTAR (STANDARD CHARACTER)**. WORTH, NICOLE, (U.S. CLS. 22 AND 39). SN 85-232,732. PUB. 6-7-2011. FILED 2-2-2011.
- 4,016,030. **BLU HEAVEN (STANDARD CHARACTER)**. ALLIANCE APPAREL, INC., (U.S. CLS. 22 AND 39). SN 85-233,211. PUB. 6-7-2011. FILED 2-3-2011.
- 4,016,078. **COMPONIX (STANDARD CHARACTER)**. KELLWOOD COMPANY, (U.S. CLS. 22 AND 39). SN 85-240,494. PUB. 6-7-2011. FILED 2-11-2011.
- 4,016,082. **PORTOLANO (STANDARD CHARACTER)**. PORTOLANO PRODUCTS, INC., (U.S. CLS. 22 AND 39). SN 85-243,437. PUB. 6-7-2011. FILED 2-16-2011.
- 4,016,083. **BADGER SPORT (STANDARD CHARACTER)**. BADGER SPORTSWEAR, (U.S. CLS. 22 AND 39). SN 85-245,301. PUB. 6-7-2011. FILED 2-17-2011.
- 4,016,084. **BADGER CUSTOM (STANDARD CHARACTER)**. BADGER SPORTSWEAR, (U.S. CLS. 22 AND 39). SN 85-245,314. PUB. 6-7-2011. FILED 2-17-2011.
- 4,016,085. **BADGER OUTDOOR (STANDARD CHARACTER)**. BADGER SPORTSWEAR, (U.S. CLS. 22 AND 39). SN 85-245,322. PUB. 6-7-2011. FILED 2-17-2011.
- 4,016,105. **PORTOLANO SINCE 1895 AND DESIGN**. PORTOLANO PRODUCTS, INC., (U.S. CLS. 22 AND 39). SN 85-256,226. PUB. 6-7-2011. FILED 3-2-2011.
- 4,016,108. **BRAND NEW LIFE AND DESIGN**. HUGHLEY, JAY, (U.S. CLS. 22 AND 39). SN 85-259,474. PUB. 6-7-2011. FILED 3-7-2011.
- 4,016,116. **TUM TUM (STANDARD CHARACTER)**. VA BIEN INTERNATIONAL, INC., (U.S. CLS. 22 AND 39). SN 85-263,310. PUB. 6-7-2011. FILED 3-10-2011.
-
- CLASS 26—FANCY GOODS**
- 4,014,275. **PHUTEN (STANDARD CHARACTER)**. NINTENDO CO., LTD., (U.S. CLS. 37, 39, 40, 42 AND 50). SN 77-601,517. PUB. 6-7-2011. FILED 10-27-2008.
- 4,015,525 (*See Class 16 for this trademark*).
-
- CLASS 27—FLOOR COVERINGS**
- 4,014,468 (*See Class 4 for this trademark*).
- 4,015,065 (*See Class 9 for this trademark*).
-
- CLASS 28—TOYS AND SPORTING GOODS**
- 4,014,229. **COLORAGGED KIDS (STANDARD CHARACTER)**. ONEIDA L. RAFI-MUHAMMAD, (U.S. CLS. 22, 23, 38 AND 50). SN 76-706,179. PUB. 6-7-2011. FILED 1-31-2011.
- 4,014,253 (*See Class 9 for this trademark*).
- 4,014,254 (*See Class 9 for this trademark*).
- 4,014,255. **ZING AND DESIGN**. ZING TOYS, INC., (U.S. CLS. 22, 23, 38 AND 50). SN 77-362,152. PUB. 6-7-2011. FILED 12-31-2007.
- 4,014,266. **CHRISTENSON SURFBOARDS (STANDARD CHARACTER)**. CHRISTENSON, CHRIS, (U.S. CLS. 22, 23, 38 AND 50). SN 77-562,220. PUB. 8-18-2009. FILED 9-4-2008.
- 4,014,269. **WII SPORTS RESORT (STYLIZED)**. NINTENDO OF AMERICA INC., (U.S. CLS. 22, 23, 38 AND 50). SN 77-583,741. PUB. 10-12-2010. FILED 10-2-2008.
- 4,014,271 (*See Class 9 for this trademark*).
- 4,014,273. **SPEEDY STRAP (STANDARD CHARACTER)**. TRAILTEK, INC., (U.S. CLS. 22, 23, 38 AND 50). SN 77-594,691. PUB. 6-7-2011. FILED 10-17-2008.
- 4,014,274. **PHUTEN (STANDARD CHARACTER)**. NINTENDO CO., LTD., (U.S. CLS. 22, 23, 38 AND 50). SN 77-601,513. PUB. 6-7-2011. FILED 10-27-2008.
- 4,014,366 (*See Class 25 for this trademark*).
- 4,014,439. **MISCELLANEOUS DESIGN**. YTV CANADA, INC., MULTIPLE CLASS, (INT. CLS. 28 AND 41), (U.S. CLS. 22, 23, 38, 50, 100, 101 AND 107). SN 78-764,983. PUB. 6-7-2011. FILED 12-1-2005.
- 4,014,542 (*See Class 11 for this trademark*).
- 4,014,565 (*See Class 10 for this trademark*).
- 4,014,580 (*See Class 9 for this trademark*).
- 4,014,583 (*See Class 9 for this trademark*).
- 4,014,593 (*See Class 9 for this trademark*).
- 4,014,594 (*See Class 24 for this trademark*).
- 4,014,634 (*See Class 25 for this trademark*).
- 4,014,731 (*See Class 6 for this trademark*).
- 4,014,742. **LAPORTE BOW-TRAP SINCE 1927 AND DESIGN**. LAPORTE HOLDING, (U.S. CLS. 22, 23, 38 AND 50). SN 85-056,014. PUB. 6-7-2011. FILED 6-7-2010.
- 4,014,745 (*See Class 14 for this trademark*).
- 4,014,748. **MISCELLANEOUS DESIGN**. LYTLE ENTERPRISES, LLC, (U.S. CLS. 22, 23, 38 AND 50). SN 85-057,302. PUB. 6-7-2011. FILED 6-8-2010.
- 4,014,770. **JUST JUMP IT (STANDARD CHARACTER)**. JUST JUMP IT, INC., (U.S. CLS. 22, 23, 38 AND 50). SN 85-064,809. PUB. 6-7-2011. FILED 6-16-2010.
- 4,014,771. **JUST JUMP IT AND DESIGN**. JUST JUMP IT, INC., (U.S. CLS. 22, 23, 38 AND 50). SN 85-064,811. PUB. 6-7-2011. FILED 6-16-2010.
- 4,014,806. **MISCELLANEOUS DESIGN**. ZIPFY, INC., (U.S. CLS. 22, 23, 38 AND 50). SN 85-073,047. PUB. 6-7-2011. FILED 6-28-2010.
- 4,014,844. **FUZZLES (STANDARD CHARACTER)**. DOUGLAS COMPANY, INC., (U.S. CLS. 22, 23, 38 AND 50). SN 85-079,643. PUB. 6-7-2011. FILED 7-7-2010.
- 4,014,875. **AMC CANISTERS OF FUN (STANDARD CHARACTER)**. AMC SALES, INC., (U.S. CLS. 22, 23, 38 AND 50). SN 85-086,832. PUB. 6-7-2011. FILED 7-16-2010.
- 4,014,894. **CULTURENIK (STANDARD CHARACTER)**. CULTURENIK PUBLISHING, INC., (U.S. CLS. 22, 23, 38 AND 50). SN 85-090,974. PUB. 6-7-2011. FILED 7-22-2010.
- 4,014,953. **DELTA TACKLE AND DESIGN**. GIBBS-NORTAC INDUSTRIES LTD., (U.S. CLS. 22, 23, 38 AND 50). SN 85-103,452. PUB. 6-7-2011. FILED 8-9-2010.
- 4,014,995. **ZING-RING (STANDARD CHARACTER)**. ZING TOYS, INC., (U.S. CLS. 22, 23, 38 AND 50). SN 85-119,938. PUB. 6-7-2011. FILED 8-31-2010.
- 4,015,028. **ORANGE PEEL (STANDARD CHARACTER)**. JIMMY HACK GOLF, LLC, (U.S. CLS. 22, 23, 38 AND 50). SN 85-125,772. PUB. 6-7-2011. FILED 9-9-2010.
- 4,015,115 (*See Class 9 for this trademark*).
- 4,015,167. **FORECLOSUREPOLY (STANDARD CHARACTER)**. COMMERCE AMERICA INC., (U.S. CLS. 22, 23, 38 AND 50). SN 85-168,292. PUB. 6-7-2011. FILED 11-3-2010.
- 4,015,171. **BOTTLE BASH (STANDARD CHARACTER)**. POLISH SPORTS, LLC, (U.S. CLS. 22, 23, 38 AND 50). SN 85-170,020. PUB. 6-7-2011. FILED 11-5-2010.
- 4,015,249. **SPLASHY DASHERS BY TOYSMITH AND DESIGN**. TOY INVESTMENTS INC., DBA TOYSMITH, (U.S. CLS. 22, 23, 38 AND 50). SN 85-191,539. PUB. 6-7-2011. FILED 12-6-2010.
- 4,015,285 (*See Class 18 for this trademark*).
- 4,015,327. **SKIM DISK (STANDARD CHARACTER)**. LIFE-TIME TOYS PTY LTD, (U.S. CLS. 22, 23, 38 AND 50). SN 85-203,444. PUB. 6-7-2011. FILED 12-21-2010.
- 4,015,420. **EVERYWHERE TOY (STANDARD CHARACTER)**. JOHN S. PIRRETTI, (U.S. CLS. 22, 23, 38 AND 50). SN 85-214,716. PUB. 6-7-2011. FILED 1-11-2011.
- 4,015,525 (*See Class 16 for this trademark*).
- 4,015,586. **TE AND DESIGN**. TENKARA USA, (U.S. CLS. 22, 23, 38 AND 50). SN 85-221,702. PUB. 6-7-2011. FILED S.R. 1-20-2011; AM. P.R. 4-18-2011.
- 4,015,637. **VAMPETS (STANDARD CHARACTER)**. JAY KAMHI, AND GAYLE MIDDLETON, (U.S. CLS. 22, 23, 38 AND 50). SN 85-222,991. PUB. 6-7-2011. FILED 1-21-2011.
- 4,015,647. **POOCH BALL (STANDARD CHARACTER)**. KOLLER ENTERPRISES, INC., DBA HAWKEYE INTERNATIONAL, (U.S. CLS. 22, 23, 38 AND 50). SN 85-223,608. PUB. 6-7-2011. FILED 1-21-2011.
- 4,015,673. **TWILIGHT SPARKLE (STANDARD CHARACTER)**. HASBRO, INC., (U.S. CLS. 22, 23, 38 AND 50). SN 85-225,128. PUB. 6-7-2011. FILED 1-25-2011.
- 4,015,703. **RIO (STANDARD CHARACTER)**. RIO PRODUCTS

- INTL., INC., (U.S. CLS. 22, 23, 38 AND 50). SN 85-226,842. PUB. 6-7-2011. FILED 1-26-2011.
- 4,015,708. **TOURSPX (STANDARD CHARACTER)**. UNITED SPORTS TECHNOLOGIES, LP, DBA UST MAMIYA, (U.S. CLS. 22, 23, 38 AND 50). SN 85-227,118. PUB. 6-7-2011. FILED 1-26-2011.
- 4,015,903. **CTRL (STANDARD CHARACTER)**. PLAN B DESIGN, LLC, (U.S. CLS. 22, 23, 38 AND 50). SN 85-230,896. PUB. 6-7-2011. FILED 2-1-2011.
- 4,015,944. **ABSPAK (STANDARD CHARACTER)**. O'SHEA, CLAYTON, (U.S. CLS. 22, 23, 38 AND 50). SN 85-231,529. PUB. 6-7-2011. FILED 2-1-2011.
- 4,016,007. **SURE! (STANDARD CHARACTER)**. SURE! LLC, (U.S. CLS. 22, 23, 38 AND 50). SN 85-232,673. PUB. 6-7-2011. FILED 2-2-2011.
- 4,016,026. **DYNA NIP (STANDARD CHARACTER)**. SWAG COMPANY, INC., (U.S. CLS. 22, 23, 38 AND 50). SN 85-233,053. PUB. 6-7-2011. FILED 2-3-2011.
- 4,016,065. **PLAYTIVITY AND DESIGN**. DOUGLAS COMPANY, INC., (U.S. CLS. 22, 23, 38 AND 50). SN 85-238,575. PUB. 6-7-2011. FILED 2-10-2011.
- 4,016,066. **PLAYTIVITY (STANDARD CHARACTER)**. DOUGLAS COMPANY, INC., (U.S. CLS. 22, 23, 38 AND 50). SN 85-238,579. PUB. 6-7-2011. FILED 2-10-2011.
- 4,016,098. **PAIZO (STANDARD CHARACTER)**. PAIZO PUBLISHING, LLC, (U.S. CLS. 22, 23, 38 AND 50). SN 85-251,659. PUB. 6-7-2011. FILED 2-25-2011.
-
- CLASS 29—MEATS AND PROCESSED FOODS**
- 4,014,206. **IN-FLIGHT CAFÉ (STANDARD CHARACTER)**. ARLINGTON SERVICES, INC., MULTIPLE CLASS, (INT. CLS. 29 AND 30), (U.S. CL. 46). SN 76-701,123. PUB. 6-7-2011. FILED 1-8-2010.
- 4,014,213. **BALL-BUSTER'S (STANDARD CHARACTER)**. RUFO, MATTHEW A., (U.S. CL. 46). SN 76-703,452. PUB. 6-7-2011. FILED 6-21-2010.
- 4,014,215. **INCA'S FOOD (STANDARD CHARACTER)**. PERUVIAN IMPORT COMPANY, INC., MULTIPLE CLASS, (INT. CLS. 29 AND 30), (U.S. CL. 46). SN 76-703,748. PUB. 6-7-2011. FILED 7-12-2010.
- 4,014,271 (*See Class 9 for this trademark*).
- 4,014,327 (*See Class 3 for this trademark*).
- 4,014,367. **GENOMAR (STANDARD CHARACTER)**. GENOMAR AS, MULTIPLE CLASS, (INT. CLS. 29 AND 31), (U.S. CLS. 1 AND 46). SN 77-891,038. PUB. 6-7-2011. FILED 12-10-2009.
- 4,014,368. **GENOMAR SAFE SUSTAINABLE SEA HARVEST AND DESIGN**. GENOMAR AS, MULTIPLE CLASS, (INT. CLS. 29 AND 31), (U.S. CLS. 1 AND 46). SN 77-891,040. PUB. 6-7-2011. FILED 12-10-2009.
- 4,014,369. **TRAPIA (STANDARD CHARACTER)**. GENOMAR AS, MULTIPLE CLASS, (INT. CLS. 29 AND 31), (U.S. CLS. 1 AND 46). SN 77-891,045. PUB. 6-7-2011. FILED 12-10-2009.
- 4,014,370. **TRAPIA TRACEABLE TILAPIA AND DESIGN**. GENOMAR AS, MULTIPLE CLASS, (INT. CLS. 29 AND 31), (U.S. CLS. 1 AND 46). SN 77-891,049. PUB. 6-7-2011. FILED 12-10-2009.
- 4,014,423. **WINTER'S FINEST NATURALLY GROWN (STANDARD CHARACTER)**. CAADES SINALOA, A.C., MULTIPLE CLASS, (INT. CLS. 29, 31 AND 35), (U.S. CLS. 1, 46, 100, 101 AND 102). SN 77-964,100. PUB. 6-7-2011. FILED 3-20-2010.
- 4,014,457 (*See Class 5 for this trademark*).
- 4,014,469 (*See Class 1 for this trademark*).
- 4,014,492. **BONAFARM AND DESIGN**. BONAFARM ZRT., MULTIPLE CLASS, (INT. CLS. 29, 30, 31, 32, 33, 35, 36, 40 AND 43), (U.S. CLS. 1, 45, 46, 47, 48, 49, 100, 101, 102, 103 AND 106). SN 79-082,418. PUB. 6-7-2011. FILED 4-8-2010.
- 4,014,499. **CASATELLA TREVIGIANA (STANDARD CHARACTER)**. MINISTERO DELLE POLITICHE AGRICOLE.; ALIMENTARI E FORESTALI -; DIPARTIMENTO DELLE POLITICHE; COMPETITIVE DEL MONDO RURALE; E DELLA QUALITA' -; DIREZIONE GENERALE PER LO SVILUPPO AGROALIMENTARE.; LA QUALITA' E LA TUTELA; DEL CONSUMATORE, (U.S. CL. 46). SN 79-083,567. PUB. 6-7-2011. FILED 4-16-2010.
- 4,014,500. **LAMETIA (STANDARD CHARACTER)**. MINISTERO DELLE POLITICHE AGRICOLE, ALIMENTARI E FORESTALI - DIPARTIMENTO DELLE POLITICHE COMPETITIVE DEL MONDO RURALE E DELLA QUALITA' - DIREZIONE GENERALE PER LO SVILUPPO AGROALIMENTARE LA QUALITA' E LA TUTELA DEL CONSUMATORE, (U.S. CL. 46). SN 79-083,577. PUB. 6-7-2011. FILED 4-19-2010.
- 4,014,501. **FROMI AND DESIGN**. FROMI FRANCE SARL, (U.S. CL. 46). SN 79-083,637. PUB. 6-7-2011. FILED 6-4-2010.
- 4,014,514. **MISCELLANEOUS DESIGN**. GANSUJUPENG INDUSTRY AND TRADE CO., LTD., MULTIPLE CLASS, (INT. CLS. 29 AND 31), (U.S. CLS. 1 AND 46). SN 79-084,872. PUB. 6-7-2011. FILED 6-29-2010.
- 4,014,619. **PACIFICAL (STANDARD CHARACTER)**. BRUS HOLDING EUROPE B.V., (U.S. CL. 46). SN 79-091,142. PUB. 6-7-2011. FILED 11-25-2010.
- 4,014,640. **FORMAGGI LACESA LATTERIA CENTRO SARDEGNA DAL 1907 AND DESIGN**. LA.CE.SA. SOC. COOP, (U.S. CL. 46). SN 79-093,072. PUB. 6-7-2011. FILED 12-20-2010.
- 4,014,647. **LANDANA (STYLIZED)**. VANDERSTERRE GROEP INTERNATIONAL B.V., (U.S. CL. 46). SN 79-094,483. PUB. 6-7-2011. FILED 12-28-2010.
- 4,014,670. **1853 (STYLIZED)**. HERR HOLDINGS INC., (U.S. CL. 46). SN 85-005,051. PUB. 6-7-2011. FILED S.R. 4-2-2010; AM. P.R. 4-28-2011.
- 4,014,681. **COUNTRY PLEASURES (STANDARD CHARACTER)**. PROCESSORS CO-OP, INC, (U.S. CL. 46). SN 85-019,069. PUB. 6-7-2011. FILED 4-21-2010.
- 4,014,706. **BMCARE AND DESIGN**. BIOSTIME, INC. (- GUANGZHOU), (U.S. CL. 46). SN 85-039,520. PUB. 3-1-2011. FILED 5-15-2010.
- 4,014,713. **BIG EASY GUMBO (STANDARD CHARACTER)**. WALTON STREET BREWING CORP., DBA EMPIRE BREWING COMPANY, (U.S. CL. 46). SN 85-042,983. PUB. 6-7-2011. FILED 5-19-2010.
- 4,014,715. **PUFFBALL (STANDARD CHARACTER)**. THE IRISH LION, INC., (U.S. CL. 46). SN 85-044,654. PUB. 6-7-2011. FILED 5-21-2010.
- 4,014,728. **FRUITYJELLY MARMALADE (STYLIZED)**. FREEDOM CANDY, INC., (U.S. CL. 46). SN 85-051,084. PUB. 6-7-2011. FILED 5-31-2010.
- 4,014,790. **CROWN DELUXE (STANDARD CHARACTER)**. BARON INTERNATIONAL TRADING LTD., MULTIPLE CLASS, (INT. CLS. 29 AND 30), (U.S. CL. 46). SN 85-069,255. PUB. 6-7-2011. FILED 6-23-2010.
- 4,014,812 (*See Class 5 for this trademark*).
- 4,014,900. **BRING INNER PEACE...TO YOUR HUNGER! (STANDARD CHARACTER)**. DEEP FOODS, INC., (U.S. CL. 46). SN 85-092,606. PUB. 6-7-2011. FILED 7-26-2010.
- 4,014,973. **CONI AND DESIGN**. NEKUTLI SA DE CV, (U.S. CL. 46). SN 85-108,232. PUB. 6-7-2011. FILED 8-16-2010.
- 4,015,025. **OLIVE WORKS BY VOLUBILIS FOODS (STANDARD CHARACTER)**. VOLUBILIS FOODS, INC., (U.S. CL. 46). SN 85-124,980. PUB. 6-7-2011. FILED 9-8-2010.
- 4,015,076. **YOLO VINEYARDS & OLIVE OIL COMPANY AND DESIGN**. YOLO VINEYARDS, (U.S. CL. 46). SN 85-141,409. PUB. 6-7-2011. FILED 9-29-2010.
- 4,015,085. **FRENCHIE FRY (STANDARD CHARACTER)**. CROBAR, L.L.C., (U.S. CL. 46). SN 85-142,841. PUB. 6-7-2011. FILED 10-1-2010.
- 4,015,235 (*See Class 5 for this trademark*).
- 4,015,399. **KIVOTOS (STANDARD CHARACTER)**. KANGADIS FOOD INC., (U.S. CL. 46). SN 85-212,970. PUB. 6-7-2011. FILED 1-7-2011.
- 4,015,537. **NEW B.C.N. AND DESIGN**. NEW B.C.N. TRADING INC., MULTIPLE CLASS, (INT. CLS. 29 AND 30), (U.S. CL. 46). SN 85-220,618. PUB. 6-7-2011. FILED 1-19-2011.
- 4,015,606. **DOLI BOUILLON EN POWDRE SEASONING POWDER 15G NATUREL 100% NATURAL AND DESIGN**. PATISEN, (U.S. CL. 46). SN 85-222,087. PUB. 6-7-2011. FILED 1-20-2011.
- 4,015,621. **THE NUTTY GOURMET (STANDARD CHARACTER)**. THE NUTTY GOURMET, LLC, MULTIPLE CLASS, (INT. CLS. 29, 30 AND 35), (U.S. CLS. 46, 100, 101 AND 102). SN 85-222,443. PUB. 6-7-2011. FILED 1-20-2011.

4,015,633. **SEAFOOD AS NATURE INTENDED (STANDARD CHARACTER)**. ALASKAN FEAST, INC., (U.S. CL. 46). SN 85-222,809. PUB. 6-7-2011. FILED 1-21-2011.

4,015,636. **LITTLE CREEK FARMS (STANDARD CHARACTER)**. LITTLE CREEK FARMS, (U.S. CL. 46). SN 85-222,910. PUB. 6-7-2011. FILED 1-21-2011.

4,015,676. **2 GUYS GOURMET AND DESIGN**. PREMIER DINING INNOVATIONS, LLC, (U.S. CL. 46). SN 85-225,388. PUB. 6-7-2011. FILED 1-25-2011.

4,015,787. **AZAR AND DESIGN**. MOUNT FRANKLIN FOODS, LLC, (U.S. CL. 46). SN 85-229,111. PUB. 6-7-2011. FILED 1-28-2011.

4,015,931. **LACASCADA (STANDARD CHARACTER)**. HENRY BROCH & COMPANY, INC., (U.S. CL. 46). SN 85-231,240. PUB. 6-7-2011. FILED 2-1-2011.

4,016,023. **APPULSE (STANDARD CHARACTER)**. WHOLE IN ONE PRODUCTS, INC., MULTIPLE CLASS, (INT. CLS. 29 AND 30), (U.S. CL. 46). SN 85-233,013. PUB. 6-7-2011. FILED 2-3-2011.

4,016,048. **STURGEON BAY CREAMERY (STANDARD CHARACTER)**. G & R FOODS, INC., (U.S. CL. 46). SN 85-233,589. PUB. 6-7-2011. FILED 2-3-2011.

4,016,080. **EL VALLE BLANCO (STANDARD CHARACTER)**. PERFORMANCE FOOD GROUP, INC., (U.S. CL. 46). SN 85-242,749. PUB. 6-7-2011. FILED 2-15-2011.

CLASS 30—STAPLE FOODS

4,014,206 (*See Class 29 for this trademark*).

4,014,215 (*See Class 29 for this trademark*).

4,014,260. **DULCIGOMAS (STANDARD CHARACTER)**. GRUPO BIMBO, S.A.B. DE C.V., (U.S. CL. 46). SN 77-466,574. PUB. 6-7-2011. FILED 5-6-2008.

4,014,271 (*See Class 9 for this trademark*).

4,014,305. **LA TAPATIA (STANDARD CHARACTER)**. LA TAPATIA TORTILLERIA, INC., (U.S. CL. 46). SN 77-728,732. PUB. 12-14-2010. FILED 5-4-2009.

4,014,327 (*See Class 3 for this trademark*).

4,014,431. **BISCOFF (STANDARD CHARACTER)**. LOTUS BAKERIES, (U.S. CL. 46). SN 77-982,339. PUB. 2-15-2011. FILED 11-2-2009.

4,014,438. **CHADO (STANDARD CHARACTER)**. SHAH, DEVAN, MULTIPLE CLASS, (INT. CLS. 30, 35 AND 43), (U.S. CLS. 46, 100, 101 AND 102). SN 78-613,030. PUB. 6-7-2011. FILED 4-20-2005.

4,014,442. **TIFF'S TREATS COOKIE DELIVERY AND DESIGN**. TIFF'S TREATS HOLDINGS, INC., MULTIPLE CLASS, (INT. CLS. 30, 39 AND 43), (U.S. CLS. 46, 100, 101 AND 105). SN 78-974,774. PUB. 6-7-2011. FILED 9-14-2006.

4,014,457 (*See Class 5 for this trademark*).

4,014,469 (*See Class 1 for this trademark*).

4,014,492 (*See Class 29 for this trademark*).

4,014,526. **PANEROMA AND DESIGN**. LANTMÄNNEN UNIBAKE DENMARK A/S, (U.S. CL. 46). SN 79-085,560. PUB. 6-7-2011. FILED 7-15-2010.

4,014,537. **HATTING AND DESIGN**. LANTMÄNNEN UNIBAKE DENMARK A/S, (U.S. CL. 46). SN 79-086,097. PUB. 6-7-2011. FILED 7-15-2010.

4,014,538. **PASTRIDOR ROYAL PASTRY AND DESIGN**. LANTMÄNNEN UNIBAKE DENMARK A/S, (U.S. CL. 46). SN 79-086,098. PUB. 6-7-2011. FILED 7-15-2010.

4,014,539. **SUCROGEN AND DESIGN**. SUCROGEN LIMITED, (U.S. CL. 46). SN 79-086,115. PUB. 6-7-2011. FILED 7-23-2010.

4,014,627. **EUAMOCHOCO (STANDARD CHARACTER)**. WIEBOLD-CONFISERIE GMBH & CO. KG, (U.S. CL. 46). SN 79-091,559. PUB. 6-7-2011. FILED 11-2-2010.

4,014,679. **AEGEAN SALAD DRESSING (STANDARD CHARACTER)**. U.S. FOODSERVICE, INC., (U.S. CL. 46). SN 85-018,302. PUB. 6-7-2011. FILED 4-20-2010.

4,014,685. **CASABE BUREN (STANDARD CHARACTER)**. ALIMENTOS FORTUNA, S.A., (U.S. CL. 46). SN 85-027,984. PUB. 6-7-2011. FILED 4-30-2010.

4,014,707. **BMCARE AND DESIGN**. BIOSTIME, INC. (GUANGZHOU), (U.S. CL. 46). SN 85-039,525. PUB. 3-1-2011. FILED 5-15-2010.

4,014,790 (*See Class 29 for this trademark*).

4,014,812 (*See Class 5 for this trademark*).

4,014,834. **XAN (STANDARD CHARACTER)**. TA-XAN AG, MULTIPLE CLASS, (INT. CLS. 30 AND 32), (U.S. CLS. 45, 46 AND 48). SN 85-077,821. PUB. 6-7-2011. FILED 7-4-2010.

4,014,876. **NATURE'S TRIBUTE (STANDARD CHARACTER)**. GALLUZZO, JOHN J., (U.S. CL. 46). SN 85-086,947. PUB. 6-7-2011. FILED 7-16-2010.

4,014,921. **CHEF'S CHOICE AND DESIGN**. FLAVORCRAFT, LLC, (U.S. CL. 46). SN 85-094,956. PUB. 6-7-2011. FILED 7-28-2010.

4,014,932. **MOO THRU REAL ICE CREAM FROM REAL DAIRY FARMERS AND DESIGN**. MOO THRU LLC, (U.S. CL. 46). SN 85-097,021. PUB. 6-7-2011. FILED 7-30-2010.

4,014,946. **MONEDAS RICOLINO AND DESIGN**. GRUPO BIMBO, S.A. B. DE C.V., (U.S. CL. 46). SN 85-101,238. PUB. 3-15-2011. FILED 8-5-2010.

4,014,959. **THE ORIGINAL BROOKLYN WATER BAGEL CO. (STANDARD CHARACTER)**. THE ORIGINAL BROOKLYN WATER BAGEL CO., INC., MULTIPLE CLASS, (INT. CLS. 30, 32 AND 43), (U.S. CLS. 45, 46, 48, 100 AND 101). SN 85-104,409. PUB. 6-7-2011. FILED 8-10-2010.

4,014,988. **SLACKER SAUCES AND DESIGN**. PIERCE COLEMAN INC., (U.S. CL. 46). SN 85-116,166. PUB. 6-7-2011. FILED 8-26-2010.

4,015,006. **LOU DOGS (STANDARD CHARACTER)**. CHRISTIAN SUBASHI, (U.S. CL. 46). SN 85-121,311. PUB. 6-7-2011. FILED 9-1-2010.

4,015,092. **RAZZIE TEA (STANDARD CHARACTER)**. CROBAR, L.L.C., (U.S. CL. 46). SN 85-145,014. PUB. 6-7-2011. FILED 10-5-2010.

4,015,175. **BUNNYFIELDS (STANDARD CHARACTER)**. 1161396 ONTARIO INC., (U.S. CL. 46). SN 85-170,864. PUB. 5-17-2011. FILED 11-6-2010.

4,015,236. **PULSIN' AND DESIGN**. PULSIN' LTD, (U.S. CL. 46). SN 85-187,915. PUB. 6-7-2011. FILED 12-1-2010.

4,015,308. **BIG BEN (STANDARD CHARACTER)**. LE PALAIS DES THES S.A., (U.S. CL. 46). SN 85-201,956. PUB. 6-7-2011. FILED 12-20-2010.

4,015,312. **THE CHALLAH FAIRY (STANDARD CHARACTER)**. THE CHALLAH FAIRY INC., MULTIPLE CLASS, (INT. CLS. 30 AND 35), (U.S. CLS. 46, 100, 101 AND 102). SN 85-202,083. PUB. 6-7-2011. FILED 12-20-2010.

4,015,356. **CHOCOLATE FOR THE SPIRIT (STANDARD CHARACTER)**. BOLEJACK, JULIE K., (U.S. CL. 46). SN 85-208,329. PUB. 6-7-2011. FILED 12-30-2010.

4,015,375. **DREW'S ORGANIC (STANDARD CHARACTER)**. WOHRLE, COLIN D., (U.S. CL. 46). SN 85-210,403. PUB. 6-7-2011. FILED 1-4-2011.

4,015,377. **MR. STICKY'S (STANDARD CHARACTER)**. MR. STICKY'S, INC, (U.S. CL. 46). SN 85-210,645. PUB. 6-7-2011. FILED 1-5-2011.

4,015,400. **LAZER SAUCE LIGHTS UP ANY MEAL (STANDARD CHARACTER)**. STRANISE LLC, DBA LAZER SAUCE, (U.S. CL. 46). SN 85-213,118. PUB. 6-7-2011. FILED 1-7-2011.

4,015,401. **CLOISTER HONEY AND DESIGN**. CLOISTER HONEY, LLC, (U.S. CL. 46). SN 85-213,152. PUB. 6-7-2011. FILED 1-7-2011.

4,015,495. **G AND DESIGN**. WHAT'S YOUR GRIND LLC, MULTIPLE CLASS, (INT. CLS. 30 AND 35), (U.S. CLS. 46, 100, 101 AND 102). SN 85-219,167. PUB. 6-7-2011. FILED 1-17-2011.

4,015,517. **T TATE'S BAKE SHOP AND DESIGN**. TATE'S BAKE SHOP, INC., (U.S. CL. 46). SN 85-219,730. PUB. 6-7-2011. FILED 1-18-2011.

4,015,537 (*See Class 29 for this trademark*).

4,015,572. **MAGNOLIA MAGNOLIA BAKERY NEW YORK CITY AND DESIGN**. MAGNOLIA OPERATING, LLC, MULTIPLE CLASS, (INT. CLS. 30 AND 35), (U.S. CLS. 46, 100, 101 AND 102). SN 85-221,372. PUB. 6-7-2011. FILED 1-19-2011.

4,015,573. **SUN CUPS (STANDARD CHARACTER)**. SETH ELLIS CHOCOLATIER, LLC, (U.S. CL. 46). SN 85-221,379. PUB. 6-7-2011. FILED 1-19-2011.

4,015,595. **SWEETS 4U2 DELICIOUSLY HEALTHY AND DESIGN**. MOORE, JACQUELINE, (U.S. CL. 46). SN 85-221,857. PUB. 6-7-2011. FILED 1-20-2011.

4,015,611. **CHOCOPAIN YA PAS MIEUX DANS TON PAIN**

- PÂTE À TARTINER CHOCOLATÉE AUX CACAHUËTES AND DESIGN.** PATISEN, (U.S. CL. 46). SN 85-222,247. PUB. 6-7-2011. FILED 1-20-2011.
- 4,015,621 (*See Class 29 for this trademark*).
- 4,015,628. **DISTIRA AND DESIGN.** TISANE BOTANICAL BREWS LLC, DBA DISTIRA TISANES, (U.S. CL. 46). SN 85-222,645. PUB. 6-7-2011. FILED 1-20-2011.
- 4,015,638. **SURF SALT (STANDARD CHARACTER).** SURF SALT LLC, (U.S. CL. 46). SN 85-223,022. PUB. 6-7-2011. FILED 1-21-2011.
- 4,015,663. **SKINNY'S SAUCES (STANDARD CHARACTER).** WALLACE, CHRISTOPHER, (U.S. CL. 46). SN 85-224,860. PUB. 6-7-2011. FILED 1-24-2011.
- 4,015,669. **VANILLA CRÊPE CHIPS THE HEALTHY COFFEE ACCOMPANIMENT AND DESIGN.** FISHER, THOMAS, (U.S. CL. 46). SN 85-225,004. PUB. 6-7-2011. FILED 1-24-2011.
- 4,015,795. **ANGELL & PHELPS (STANDARD CHARACTER).** SMITH, CHARLES, (U.S. CL. 46). SN 85-229,198. PUB. 6-7-2011. FILED 1-28-2011.
- 4,015,895. **PHLIP 'N' NIK AND DESIGN.** PHLIP 'N' NIK CORPORATION, (U.S. CL. 46). SN 85-230,743. PUB. 6-7-2011. FILED 1-31-2011.
- 4,015,926. **B-SHOT (STANDARD CHARACTER).** PODHEAD.-COM, LLC, (U.S. CL. 46). SN 85-231,192. PUB. 6-7-2011. FILED 2-1-2011.
- 4,015,955. **MAMA TESSIE'S (STANDARD CHARACTER).** D'ORAZIO FOODS, INC., (U.S. CL. 46). SN 85-231,710. PUB. 6-7-2011. FILED 2-1-2011.
- 4,016,023 (*See Class 29 for this trademark*).
- 4,016,043. **ANOVA COFFEE (STANDARD CHARACTER).** ANOVA COFFEE, LLC, (U.S. CL. 46). SN 85-233,541. PUB. 6-7-2011. FILED 2-3-2011.
- 4,016,121. **MUCHO CHEESE (STANDARD CHARACTER).** INTEREX CORP., (U.S. CL. 46). SN 85-266,724. PUB. 6-7-2011. FILED 3-14-2011.
- 4,016,122. **SI SENOR CHARRITOS (STANDARD CHARACTER).** INTEREX CORP., (U.S. CL. 46). SN 85-267,902. PUB. 6-7-2011. FILED 3-15-2011.
- 4,016,123. **SI SENOR MUCHO CHEESE (STANDARD CHARACTER).** INTEREX CORP., (U.S. CL. 46). SN 85-267,907. PUB. 6-7-2011. FILED 3-15-2011.
- 4,016,126. **THE TWILIGHT SAGA (STANDARD CHARACTER).** SUMMIT ENTERTAINMENT, LLC, (U.S. CL. 46). SN 85-279,316. PUB. 6-7-2011. FILED 3-29-2011.
- 4,014,514 (*See Class 29 for this trademark*).
- 4,014,700. **MISCELLANEOUS DESIGN.** DESERT GLORY, LTD., (U.S. CLS. 1 AND 46). SN 85-036,976. PUB. 6-7-2011. FILED 5-12-2010.
- 4,014,717 (*See Class 19 for this trademark*).
- 4,014,762. **FARM SCIENCE GENETICS (STANDARD CHARACTER).** ALLIED SEED, LLC, (U.S. CLS. 1 AND 46). SN 85-063,460. PUB. 6-7-2011. FILED 6-15-2010.
- 4,014,835. **RUBY SENSATION (STANDARD CHARACTER).** TASTEFUL SELECTIONS, LLC, (U.S. CLS. 1 AND 46). SN 85-077,897. PUB. 6-7-2011. FILED 7-5-2010.
- 4,014,854. **YOUR FRIENDS IN FRESHNESS (STANDARD CHARACTER).** GREENHOUSE GROWN FOODS INC., (U.S. CLS. 1 AND 46). SN 85-081,970. PUB. 6-7-2011. FILED 7-10-2010.
- 4,014,871 (*See Class 5 for this trademark*).
- 4,014,983. **OMEGAEQUIS AND DESIGN.** OMEGA PROTEIN, INC., (U.S. CLS. 1 AND 46). SN 85-114,739. PUB. 6-7-2011. FILED 8-24-2010.
- 4,015,262. **SOLAR SPICE (STANDARD CHARACTER).** HORTECH, INC., (U.S. CLS. 1 AND 46). SN 85-194,886. PUB. 6-7-2011. FILED 12-10-2010.
- 4,015,263. **SUNSPASH (STANDARD CHARACTER).** HORTECH, INC., (U.S. CLS. 1 AND 46). SN 85-194,935. PUB. 6-7-2011. FILED 12-10-2010.
- 4,015,264. **MOONSHINE (STANDARD CHARACTER).** HORTECH, INC., (U.S. CLS. 1 AND 46). SN 85-194,950. PUB. 6-7-2011. FILED 12-10-2010.
- 4,015,265. **CINNABAR (STANDARD CHARACTER).** HORTECH, INC., (U.S. CLS. 1 AND 46). SN 85-194,954. PUB. 6-7-2011. FILED 12-10-2010.
- 4,015,266. **DARK DRAGON (STANDARD CHARACTER).** HORTECH, INC., (U.S. CLS. 1 AND 46). SN 85-194,972. PUB. 6-7-2011. FILED 12-10-2010.
- 4,015,267. **MINT TWIST (STANDARD CHARACTER).** HORTECH, INC., (U.S. CLS. 1 AND 46). SN 85-195,120. PUB. 6-7-2011. FILED 12-10-2010.
- 4,015,268. **SEDUM SPURIUM MOSSY (STANDARD CHARACTER).** HORTECH, INC., (U.S. CLS. 1 AND 46). SN 85-195,124. PUB. 6-7-2011. FILED 12-10-2010.
- 4,015,425. **TREE IN A BOX (STANDARD CHARACTER).** AKINS, ARTHUR J, DBA TREE IN A BOX, (U.S. CLS. 1 AND 46). SN 85-214,975. PUB. 6-7-2011. FILED 1-11-2011.
- 4,015,497. **DAILY GOLD (STANDARD CHARACTER).** REDMOND, INCORPORATED, (U.S. CLS. 1 AND 46). SN 85-219,314. PUB. 6-7-2011. FILED 1-17-2011.
- 4,015,498. **DAILY RED (STANDARD CHARACTER).** REDMOND, INCORPORATED, (U.S. CLS. 1 AND 46). SN 85-219,316. PUB. 6-7-2011. FILED 1-17-2011.
- 4,015,594 (*See Class 4 for this trademark*).
- 4,015,596 (*See Class 4 for this trademark*).
- 4,015,646. **FOREST BROWN (STANDARD CHARACTER).** HACKNEY PARKER, (U.S. CLS. 1 AND 46). SN 85-223,330. PUB. 6-7-2011. FILED 1-21-2011.

CLASS 31—NATURAL AGRICULTURAL PRODUCTS

- 4,014,271 (*See Class 9 for this trademark*).
- 4,014,307. **LA BONE BAKERY & BOUTIQUE AND DESIGN.** JESSTEVEAND, INC., (U.S. CLS. 1 AND 46). SN 77-736,351. PUB. 6-7-2011. FILED 5-13-2009.
- 4,014,327 (*See Class 3 for this trademark*).
- 4,014,367 (*See Class 29 for this trademark*).
- 4,014,368 (*See Class 29 for this trademark*).
- 4,014,369 (*See Class 29 for this trademark*).
- 4,014,370 (*See Class 29 for this trademark*).
- 4,014,423 (*See Class 29 for this trademark*).
- 4,014,469 (*See Class 1 for this trademark*).
- 4,014,492 (*See Class 29 for this trademark*).
- 4,014,504. **UVA DA TAVOLA DI MAZZARRONE (STANDARD CHARACTER).** MINISTERO DELLE POLITICHE AGRICOLE; ALIMENTARI E FORESTALI -; DIPARTIMENTO DELLE POLITICHE; COMPETITIVE DEL MONDO RURALE; E DELLA QUALITA' -; DIREZIONE GENERALE PER LO SVILUPPO AGROALIMENTARE; LA QUALITA' E LA TUTELA; DEL CONSUMATORE, (U.S. CLS. 1 AND 46). SN 79-084,226. PUB. 6-7-2011. FILED 4-23-2010.
- 4,014,505. **CASTAGNA CUNEO (STANDARD CHARACTER).** MINISTERO DELLE POLITICHE AGRICOLE; ALIMENTARI E FORESTALI -; DIPARTIMENTO DELLE POLITICHE; COMPETITIVE DEL MONDO RURALE; E DELLA QUALITA' -; DIREZIONE GENERALE PER LO SVILUPPO AGROALIMENTARE; LA QUALITA' E LA TUTELA; DEL CONSUMATORE, (U.S. CLS. 1 AND 46). SN 79-084,230. PUB. 6-7-2011. FILED 4-16-2010.

CLASS 32—LIGHT BEVERAGES

- 4,014,306 (*See Class 5 for this trademark*).
- 4,014,330. **MELLOW DAY (STANDARD CHARACTER).** MELLOW BEVERAGE CO., LLC, (U.S. CLS. 45, 46 AND 48). SN 77-812,735. PUB. 1-19-2010. FILED 8-26-2009.
- 4,014,331. **MELLOW NIGHT (STANDARD CHARACTER).** MELLOW BEVERAGE CO., LLC, (U.S. CLS. 45, 46 AND 48). SN 77-812,738. PUB. 1-19-2010. FILED 8-26-2009.
- 4,014,405. **DRINK OUT LOUD (STANDARD CHARACTER).** JARRITOS, INC., (U.S. CLS. 45, 46 AND 48). SN 77-942,132. PUB. 6-7-2011. FILED 2-23-2010.
- 4,014,433. **VAULT (STANDARD CHARACTER).** COCA-COLA COMPANY, THE, (U.S. CLS. 45, 46 AND 48). SN 78-534,888. PUB. 5-20-2008. FILED 12-17-2004.
- 4,014,435. **VAULT (STANDARD CHARACTER).** THE COCA-COLA COMPANY, (U.S. CLS. 45, 46 AND 48). SN 78-595,891. PUB. 4-15-2008. FILED 3-28-2005.
- 4,014,437. **V VAULT AND DESIGN.** THE COCA-COLA COMPANY, (U.S. CLS. 45, 46 AND 48). SN 78-599,327. PUB. 5-20-2008. FILED 3-31-2005.

4,014,469 (*See Class 1 for this trademark.*)
 4,014,492 (*See Class 29 for this trademark.*)
 4,014,517. **DR. ANTONIO MARTINS (STANDARD CHARACTER)**. GREEN COCO HOLDING AG. (U.S. CLS. 45, 46 AND 48). SN 79-085,120. PUB. 6-7-2011. FILED 6-25-2010.
 4,014,599 (*See Class 9 for this trademark.*)
 4,014,630. **HEINEKEN. OPEN YOUR WORLD (STANDARD CHARACTER)**. HEINEKEN BROUWERIJEN B.V., (U.S. CLS. 45, 46 AND 48). SN 79-092,005. PUB. 6-7-2011. FILED 12-7-2010.
 4,014,812 (*See Class 5 for this trademark.*)
 4,014,834 (*See Class 30 for this trademark.*)
 4,014,959 (*See Class 30 for this trademark.*)
 4,014,989. **YOGO VERA (STYLIZED)**. SAMJIN GLOBALNET CO., LTD., (U.S. CLS. 45, 46 AND 48). SN 85-116,279. PUB. 6-7-2011. FILED 8-26-2010.
 4,015,057. **MONKEY ICE (STANDARD CHARACTER)**. WEIGEL STORES, INC., (U.S. CLS. 45, 46 AND 48). SN 85-136,184. PUB. 6-7-2011. FILED 9-23-2010.
 4,015,959. **IHOP SPLASHERS (STANDARD CHARACTER)**. IHOP IP, LLC, (U.S. CLS. 45, 46 AND 48). SN 85-231,766. PUB. 6-7-2011. FILED 2-1-2011.
 4,016,028. **GTL FUEL (STANDARD CHARACTER)**. GTL FUEL, LLC, (U.S. CLS. 45, 46 AND 48). SN 85-233,097. PUB. 6-7-2011. FILED 2-3-2011.
 4,016,038. **VAL DE FRANCE (STANDARD CHARACTER)**. EPICUREAN FOOD AND BEVERAGES, LLC, DBA EFB, (U.S. CLS. 45, 46 AND 48). SN 85-233,420. PUB. 6-7-2011. FILED 2-3-2011.

CLASS 33—WINES AND SPIRITS

4,014,225. **VOLUNTAS EST VIA AND DESIGN**. LOEB, JOHN L. JR., (U.S. CLS. 47 AND 49). SN 76-705,733. PUB. 6-7-2011. FILED 12-20-2010.
 4,014,239. **LONGBOW (STANDARD CHARACTER)**. ARISTA WINES, LLC, (U.S. CLS. 47 AND 49). SN 76-706,244. PUB. 6-7-2011. FILED 2-2-2011.
 4,014,301. **DON ANTONIO AGUILAR (STANDARD CHARACTER)**. MACIAS MEDINA, EVERARDO, (U.S. CLS. 47 AND 49). SN 77-702,581. PUB. 6-7-2011. FILED 3-30-2009.
 4,014,334. **TRIBAL (STANDARD CHARACTER)**. AFRICAN TERROIR (PROPRIETARY) LIMITED, (U.S. CLS. 47 AND 49). SN 77-821,542. PUB. 1-26-2010. FILED 9-8-2009.
 4,014,443. **TERRAS (STANDARD CHARACTER)**. MANOEL D. POÇAS JÚNIOR-VINHOS, S.A., (U.S. CLS. 47 AND 49). SN 79-013,022. PUB. 6-7-2011. FILED 6-22-2005.
 4,014,492 (*See Class 29 for this trademark.*)
 4,014,508. **BLANCHET (STANDARD CHARACTER)**. ROTKÄPPCHEN-MUMM SEKTKELLEREIEN GMBH, (U.S. CLS. 47 AND 49). SN 79-084,559. PUB. 6-7-2011. FILED 5-21-2010.
 4,014,579. **VERNISSAGE (STANDARD CHARACTER)**. OENOFOROS AB, (U.S. CLS. 47 AND 49). SN 79-088,395. PUB. 6-7-2011. FILED 9-27-2010.
 4,014,592. **BRUME DI MONTE (STANDARD CHARACTER)**. CAVIT CANTINA VITICOLTORI CONSORZIO CANTINE SOCIALI DEL TRENTINO SOCIETÀ COOPERATIVA, (U.S. CLS. 47 AND 49). SN 79-089,422. PUB. 6-7-2011. FILED 10-28-2010.
 4,014,608. **COOL BAY (STANDARD CHARACTER)**. OENOFOROS AB, (U.S. CLS. 47 AND 49). SN 79-090,554. PUB. 6-7-2011. FILED 10-29-2010.
 4,014,636. **BURLESQUE (STANDARD CHARACTER)**. RACEMI SRL, (U.S. CLS. 47 AND 49). SN 79-092,700. PUB. 6-7-2011. FILED 12-20-2010.
 4,014,644. **MISCELLANEOUS DESIGN**. "PROSHYAN BRANDY FACTORY" LLC, (U.S. CLS. 47 AND 49). SN 79-093,452. PUB. 6-7-2011. FILED 12-13-2010.
 4,014,645. **ROCKING ANGEL (STANDARD CHARACTER)**. ASM LIQUOR PTY LTD, (U.S. CLS. 47 AND 49). SN 79-093,768. PUB. 6-7-2011. FILED 1-28-2011.
 4,014,682. **THE DAM KEEPER (STANDARD CHARACTER)**. MCWILLIAM'S WINES GROUP LTD, (U.S. CLS. 47 AND 49). SN 85-022,452. PUB. 6-7-2011. FILED 4-24-2010.
 4,014,691. **WHAT'S YOUR PINK MOMENT (STANDARD**

CHARACTER). THE FLADGATE PARTNERSHIP - VINHOS SA, (U.S. CLS. 47 AND 49). SN 85-032,579. PUB. 6-7-2011. FILED 5-7-2010.
 4,014,734. **ELLIS' FINE WINE (STANDARD CHARACTER)**. ELLIS' FINE WINES, (U.S. CLS. 47 AND 49). SN 85-052,425. PUB. 6-7-2011. FILED 6-2-2010.
 4,014,864. **LYTOS (STANDARD CHARACTER)**. MEDINRE, S.L., (U.S. CLS. 47 AND 49). SN 85-083,202. PUB. 6-7-2011. FILED 7-13-2010.
 4,015,051. **WISER'S SMALL BATCH AND DESIGN**. J.P. WISER'S DISTILLERY LIMITED, (U.S. CLS. 47 AND 49). SN 85-133,543. PUB. 6-7-2011. FILED 9-20-2010.
 4,015,143. **ROCKY BAY (STYLIZED)**. MASTER HAUS GROUP, (U.S. CLS. 47 AND 49). SN 85-160,832. PUB. 6-7-2011. FILED 10-25-2010.
 4,015,194. **PALM PEACH (STANDARD CHARACTER)**. FLORIDIAN LIQUID ASSETS, LLC, (U.S. CLS. 47 AND 49). SN 85-176,349. PUB. 6-7-2011. FILED 11-14-2010.
 4,015,302. **RAISE YOUR STANDARDS (STANDARD CHARACTER)**. EVIL MOON SPIRITS LLC, (U.S. CLS. 47 AND 49). SN 85-200,448. PUB. 6-7-2011. FILED 12-17-2010.
 4,015,349. **WINEMO! WINES AND MORE AND DESIGN**. FORTE MANAGEMENT SYSTEMS GROUP CORPORATION, DBA SAVER'S CLUB LIQUOR LOCKER AND SAVER'S CLUB WINE LOCKER, (U.S. CLS. 47 AND 49). SN 85-207,523. PUB. 6-7-2011. FILED 12-29-2010.
 4,015,470. **ESTI EXCLUSIV AND DESIGN**. SERGE IMPORT LLC, (U.S. CLS. 47 AND 49). SN 85-217,962. PUB. 6-7-2011. FILED 1-14-2011.
 4,015,502. **RED DROP AND DESIGN**. PRECEPT BRANDS, LLC, (U.S. CLS. 47 AND 49). SN 85-219,476. PUB. 6-7-2011. FILED 1-18-2011.
 4,015,503. **GOODNESS GRAPE AND DESIGN**. PRECEPT BRANDS, LLC, (U.S. CLS. 47 AND 49). SN 85-219,478. PUB. 6-7-2011. FILED 1-18-2011.
 4,015,504. **COCO ROSSO (STANDARD CHARACTER)**. PRECEPT BRANDS, LLC, (U.S. CLS. 47 AND 49). SN 85-219,479. PUB. 6-7-2011. FILED 1-18-2011.
 4,015,505. **CHOCOLATE SHOP THE CHOCOLATE LOVER'S WINE (STANDARD CHARACTER)**. PRECEPT BRANDS, LLC, (U.S. CLS. 47 AND 49). SN 85-219,482. PUB. 6-7-2011. FILED 1-18-2011.
 4,015,506. **MUDDY PAW AND DESIGN**. TREBETS, ED, AND TREBETS, GINA, (U.S. CLS. 47 AND 49). SN 85-219,507. PUB. 6-7-2011. FILED 1-18-2011.
 4,015,602. **FIRE STATION RED (STANDARD CHARACTER)**. MILDARA BLASS, INC., DBA WINDSOR VINEYARDS, (U.S. CLS. 47 AND 49). SN 85-221,995. PUB. 6-7-2011. FILED 1-20-2011.
 4,015,650. **VINEYARD 7 & 8 (STANDARD CHARACTER)**. 7 & 8, LLC, (U.S. CLS. 47 AND 49). SN 85-223,684. PUB. 6-7-2011. FILED 1-21-2011.
 4,016,042. **BIG BOTTOM WHISKEY (STANDARD CHARACTER)**. BIG BOTTOM DISTILLING, LLC, DBA BIG BOTTOM WHISKEY, (U.S. CLS. 47 AND 49). SN 85-233,511. PUB. 6-7-2011. FILED 2-3-2011.

CLASS 34—SMOKERS' ARTICLES

4,014,300. **BLU MAGIC (STANDARD CHARACTER)**. NEW IMAGE GLOBAL, INC., (U.S. CLS. 2, 8, 9 AND 17). SN 77-702,228. PUB. 7-21-2009. FILED 3-30-2009.
 4,014,839. **S SMOKESTIK AND DESIGN**. 893958 ONTARIO LTD., (U.S. CLS. 2, 8, 9 AND 17). SN 85-078,517. PUB. 6-7-2011. FILED 7-6-2010.
 4,015,899. **AMERICAN QUALITY MAVERICK CIGARETTES AND DESIGN**. LORILLARD LICENSING COMPANY, LLC, (U.S. CLS. 2, 8, 9 AND 17). SN 85-230,846. PUB. 6-7-2011. FILED 2-1-2011.

SERVICE MARKS

CLASS 35—ADVERTISING AND BUSINESS

- 4,014,200 (*See Class 3 for this trademark*).
- 4,014,207. **FLOWERSPOT.COM AND DESIGN**. FLOWER-SPOT.COM LLC, (U.S. CLS. 100, 101 AND 102). SN 76-701,667. PUB. 6-7-2011. FILED 2-17-2010.
- 4,014,214 (*See Class 9 for this trademark*).
- 4,014,217. **AQUARIAN (STANDARD CHARACTER)**. AQUARIAN, LLC, MULTIPLE CLASS, (INT. CLS. 35 AND 42), (U.S. CLS. 100, 101 AND 102). SN 76-703,928. PUB. 6-7-2011. FILED 7-27-2010.
- 4,014,219. **MATRIX BASEMENT FINISHING SYSTEM AND DESIGN**. NICK RICHMOND, MULTIPLE CLASS, (INT. CLS. 35 AND 37), (U.S. CLS. 100, 101, 102, 103 AND 106). SN 76-704,551. PUB. 6-7-2011. FILED 9-17-2010.
- 4,014,221. **EXPERIENCE TRUST. BANK ON RIVERSET. (STYLIZED)**. RIVERSET CREDIT UNION, MULTIPLE CLASS, (INT. CLS. 35 AND 36), (U.S. CLS. 100, 101 AND 102). SN 76-704,610. PUB. 6-7-2011. FILED 9-23-2010.
- 4,014,267. **MINE OF THE FUTURE (STANDARD CHARACTER)**. RIO TINTO LONDON LIMITED, MULTIPLE CLASS, (INT. CLS. 35, 37, 38, 39, 40 AND 42), (U.S. CLS. 100, 101, 102, 103, 104, 105 AND 106). SN 77-562,775. PUB. 6-7-2011. FILED 9-4-2008.
- 4,014,278. **ITHING (STANDARD CHARACTER)**. ENTERCOM COMMUNICATIONS CORP., MULTIPLE CLASS, (INT. CLS. 35, 38 AND 41), (U.S. CLS. 100, 101, 102, 104 AND 107). SN 77-604,309. PUB. 6-7-2011. FILED 10-30-2008.
- 4,014,280 (*See Class 2 for this trademark*).
- 4,014,281 (*See Class 2 for this trademark*).
- 4,014,291. **PATCH AND DESIGN**. PATCH MEDIA CORPORATION, MULTIPLE CLASS, (INT. CLS. 35, 38 AND 41), (U.S. CLS. 100, 101, 102, 104 AND 107). SN 77-668,130. PUB. 6-7-2011. FILED 2-11-2009.
- 4,014,298. **MALIBU LUMBER YARD (STANDARD CHARACTER)**. MALIBU LUMBER, LLC, MULTIPLE CLASS, (INT. CLS. 35 AND 36), (U.S. CLS. 100, 101 AND 102). SN 77-696,106. PUB. 6-7-2011. FILED S.R. 3-20-2009; AM. P.R. 10-14-2010.
- 4,014,302. **SUNDOG (STANDARD CHARACTER)**. SUNDOG INTERACTIVE, INC., (U.S. CLS. 100, 101 AND 102). SN 77-705,646. PUB. 10-26-2010. FILED 4-2-2009.
- 4,014,303. **CRVMORE (STANDARD CHARACTER)**. CHINA RESOURCES VANGUARD (HONG KONG) COMPANY LIMITED, MULTIPLE CLASS, (INT. CLS. 35, 38, 39, 41, 42 AND 45), (U.S. CLS. 100, 101, 102, 104, 105 AND 107). SN 77-718,803. PUB. 2-1-2011. FILED 4-21-2009.
- 4,014,308. **JOIELLE AND DESIGN**. JUMY LLC, DBA JOIELLE, (U.S. CLS. 100, 101 AND 102). SN 77-740,811. PUB. 6-7-2011. FILED 5-20-2009.
- 4,014,310. **HRI HORTICULTURAL RESEARCH INSTITUTE AND DESIGN**. HORTICULTURAL RESEARCH INSTITUTE, MULTIPLE CLASS, (INT. CLS. 35, 36, 42 AND 44), (U.S. CLS. 100, 101 AND 102). SN 77-741,911. PUB. 6-7-2011. FILED 5-21-2009.
- 4,014,321. **HFI HELICOPTER FOUNDATION INTERNATIONAL PRESERVING OUR HERITAGE BUILDING OUR FUTURE AND DESIGN**. HELICOPTER FOUNDATION INTERNATIONAL, MULTIPLE CLASS, (INT. CLS. 35, 36 AND 41), (U.S. CLS. 100, 101, 102 AND 107). SN 77-772,336. PUB. 6-7-2011. FILED 7-1-2009.
- 4,014,327 (*See Class 3 for this trademark*).
- 4,014,332 (*See Class 20 for this trademark*).
- 4,014,336 (*See Class 9 for this trademark*).
- 4,014,337 (*See Class 6 for this trademark*).
- 4,014,340. **KITS CAMERA & IMAGE (STANDARD CHARACTER)**. RITZ CAMERA & IMAGE, L.L.C., MULTIPLE CLASS, (INT. CLS. 35 AND 40), (U.S. CLS. 100, 101, 102, 103 AND 106). SN 77-842,114. PUB. 5-10-2011. FILED 10-6-2009.
- 4,014,342. **THE CLEVER BRIDE CAYLA AND DESIGN**. 6963803 CANADA INC., DBA THE CLEVER BRIDE, (U.S. CLS. 100, 101 AND 102). SN 77-846,182. PUB. 6-7-2011. FILED 10-11-2009.
- 4,014,348 (*See Class 7 for this trademark*).
- 4,014,356. **CREDIT KARMA (STANDARD CHARACTER)**. CREDIT KARMA, (U.S. CLS. 100, 101 AND 102). SN 77-877,674. PUB. 5-4-2010. FILED 11-20-2009.
- 4,014,360. **FRESH EXPERIENCE (STANDARD CHARACTER)**. IF&P FOODS, INC., (U.S. CLS. 100, 101 AND 102). SN 77-883,175. PUB. 6-7-2011. FILED 12-1-2009.
- 4,014,362. **AIM (STANDARD CHARACTER)**. ASSOCIATION FOR INDEPENDENT MANAGERS, INC., (U.S. CLS. 100, 101 AND 102). SN 77-887,254. PUB. 6-7-2011. FILED 12-7-2009.
- 4,014,363. **ASSOCIATION FOR INDEPENDENT MANAGERS (STANDARD CHARACTER)**. ASSOCIATION FOR INDEPENDENT MANAGERS, INC., (U.S. CLS. 100, 101 AND 102). SN 77-887,608. PUB. 6-7-2011. FILED 12-7-2009.
- 4,014,364. **SAPIENTIS ENSEANZA LIDERAZGO DESARROLLO AND DESIGN**. KRISTIN EHRGOOD, (U.S. CLS. 100, 101 AND 102). SN 77-889,447. PUB. 6-7-2011. FILED 12-9-2009.
- 4,014,373. **PS AND DESIGN**. THE SCOOP, INC., TA PRINCE-TON SCOOP, (U.S. CLS. 100, 101 AND 102). SN 77-892,460. PUB. 6-7-2011. FILED 12-14-2009.
- 4,014,381. **ISHA (STANDARD CHARACTER)**. ISHA FOUNDATION, INC., MULTIPLE CLASS, (INT. CLS. 35 AND 41), (U.S. CLS. 100, 101, 102 AND 107). SN 77-905,109. PUB. 6-7-2011. FILED 1-5-2010.
- 4,014,384. **DELIVERING YOU THE GLOBAL HARVEST (STANDARD CHARACTER)**. ATALANTA CORPORATION, (U.S. CLS. 100, 101 AND 102). SN 77-907,214. PUB. 6-7-2011. FILED 1-7-2010.
- 4,014,390. **MR. PYNK (STANDARD CHARACTER)**. PELLOW INVESTMENTS, LLC, (U.S. CLS. 100, 101 AND 102). SN 77-912,712. PUB. 6-7-2011. FILED 1-15-2010.
- 4,014,394. **GO INDIE (STANDARD CHARACTER)**. DAVID, PAUL, MULTIPLE CLASS, (INT. CLS. 35 AND 41), (U.S. CLS. 100, 101, 102 AND 107). SN 77-919,857. PUB. 6-7-2011. FILED 1-25-2010.
- 4,014,395 (*See Class 9 for this trademark*).
- 4,014,396. **NIGHTLENS (STANDARD CHARACTER)**. CALVO ENTERTAINMENT CORP., DBA CALVO ENTERTAINMENT CORP., MULTIPLE CLASS, (INT. CLS. 35 AND 45), (U.S. CLS. 100, 101 AND 102). SN 77-921,170. PUB. 6-7-2011. FILED 1-27-2010.
- 4,014,400. **SUPERIOR GAS LIQUIDS (STYLIZED)**. SUPERIOR GENERAL PARTNER INC., MULTIPLE CLASS, (INT. CLS. 35, 36 AND 39), (U.S. CLS. 100, 101, 102 AND 105). SN 77-931,021. PUB. 6-7-2011. FILED 2-8-2010.
- 4,014,401. **BIDRIVALS (STANDARD CHARACTER)**. BIDRIVALS INC., (U.S. CLS. 100, 101 AND 102). SN 77-938,412. PUB. 6-7-2011. FILED 2-18-2010.
- 4,014,408. **STAR POWER RECOMMENDED SUPPLIER AND DESIGN**. DISTRESSED PROPERTY INSTITUTE, LLC, (U.S. CLS. 100, 101 AND 102). SN 77-944,842. PUB. 1-4-2011. FILED 2-25-2010.
- 4,014,410. **BLACK COFFEE GALLERY ART AND COFFEE MADE BY ARTISTS AND DESIGN**. CAFE NEGRO GALLERIA, S. DE R.L. DE C.V., MULTIPLE CLASS, (INT. CLS. 35 AND 41), (U.S. CLS. 100, 101, 102 AND 107). SN 77-949,799. PUB. 6-7-2011. FILED 3-3-2010.
- 4,014,411 (*See Class 9 for this trademark*).
- 4,014,415. **VIRTUAL POWER PLANT AND DESIGN**. VIRTUAL POWER PLANT, (U.S. CLS. 100, 101 AND 102). SN 77-952,561. PUB. 7-27-2010. FILED 3-7-2010.
- 4,014,416. **THE SKETCHBOOK PROJECT (STANDARD CHARACTER)**. ART HOUSE, LLC, DBA ART HOUSE, MULTIPLE CLASS, (INT. CLS. 35 AND 41), (U.S. CLS. 100, 101, 102 AND 107). SN 77-952,680. PUB. 6-7-2011. FILED 3-8-2010.
- 4,014,423 (*See Class 29 for this trademark*).
- 4,014,434. **FOCALPOINT CONSULTING AND DESIGN**. ROBERT W. PATRAW, PH.D., DBA FOCAL POINT CONSULTING, (U.S. CLS. 100, 101 AND 102). SN 78-552,238. PUB. 6-7-2011. FILED 1-23-2005.
- 4,014,438 (*See Class 30 for this trademark*).
- 4,014,444 (*See Class 9 for this trademark*).
- 4,014,459. **CARTILS (STANDARD CHARACTER)**. CARTILS GROUP B.V., MULTIPLE CLASS, (INT. CLS. 35, 41 AND 42), (U.S. CLS. 100, 101, 102 AND 107). SN 79-073,682. PUB. 6-7-2011. FILED 7-23-2009.

- 4,014,464 (*See Class 3 for this trademark.*)
 4,014,475 (*See Class 16 for this trademark.*)
 4,014,476 (*See Class 3 for this trademark.*)
 4,014,478 (*See Class 3 for this trademark.*)
 4,014,480. **BIOCOOKING BC (STYLIZED)**. BAZZOLI FRANCO, MULTIPLE CLASS, (INT. CLS. 35 AND 43), (U.S. CLS. 100, 101 AND 102). SN 79-079,618. PUB. 6-7-2011. FILED 1-5-2010.
 4,014,486 (*See Class 4 for this trademark.*)
 4,014,487. **LAHMEYER (STANDARD CHARACTER)**. LAHMEYER INTERNATIONAL GMBH, MULTIPLE CLASS, (INT. CLS. 35 AND 42), (U.S. CLS. 100, 101 AND 102). SN 79-081,057. PUB. 6-7-2011. FILED 12-30-2009.
 4,014,489 (*See Class 16 for this trademark.*)
 4,014,491. **LI (STYLIZED)**. LAHMEYER INTERNATIONAL GMBH, MULTIPLE CLASS, (INT. CLS. 35 AND 42), (U.S. CLS. 100, 101 AND 102). SN 79-082,283. PUB. 6-7-2011. FILED 12-30-2009.
 4,014,492 (*See Class 29 for this trademark.*)
 4,014,494 (*See Class 9 for this trademark.*)
 4,014,496. **LIZEO (STANDARD CHARACTER)**. LIZEO ONLINE MEDIA GROUP, (U.S. CLS. 100, 101 AND 102). SN 79-082,736. PUB. 6-7-2011. FILED 12-11-2009.
 4,014,503 (*See Class 9 for this trademark.*)
 4,014,506 (*See Class 1 for this trademark.*)
 4,014,509 (*See Class 9 for this trademark.*)
 4,014,515 (*See Class 9 for this trademark.*)
 4,014,521 (*See Class 9 for this trademark.*)
 4,014,530 (*See Class 9 for this trademark.*)
 4,014,533 (*See Class 25 for this trademark.*)
 4,014,553. **FESTIVAL SCOPE (STANDARD CHARACTER)**. RAJA ALESSANDRO, MULTIPLE CLASS, (INT. CLS. 35 AND 41), (U.S. CLS. 100, 101, 102 AND 107). SN 79-086,941. PUB. 6-7-2011. FILED 5-10-2010.
 4,014,560. **HACKFWD AND DESIGN**. HACKFWD GMBH & CO. KG, MULTIPLE CLASS, (INT. CLS. 35, 36 AND 42), (U.S. CLS. 100, 101 AND 102). SN 79-087,272. PUB. 6-7-2011. FILED 6-29-2010.
 4,014,561. **HACK FORWARD (STANDARD CHARACTER)**. HACKFWD GMBH & CO. KG, MULTIPLE CLASS, (INT. CLS. 35, 36 AND 42), (U.S. CLS. 100, 101 AND 102). SN 79-087,273. PUB. 6-7-2011. FILED 6-29-2010.
 4,014,570. **BIO INTELLIGENCE SERVICE (STANDARD CHARACTER)**. BIO CAPITAL SAS, MULTIPLE CLASS, (INT. CLS. 35, 36, 37, 38, 39, 40, 41, 42 AND 43), (U.S. CLS. 100, 101, 102, 103, 104, 105, 106 AND 107). SN 79-087,848. PUB. 6-7-2011. FILED 3-16-2010.
 4,014,571. **BIO INTELLIGENCE SERVICE AND DESIGN**. BIO CAPITAL SAS, MULTIPLE CLASS, (INT. CLS. 35, 36, 37, 38, 39, 40, 41, 42 AND 43), (U.S. CLS. 100, 101, 102, 103, 104, 105, 106 AND 107). SN 79-087,862. PUB. 6-7-2011. FILED 7-9-2010.
 4,014,591. **YOGORINO AND DESIGN**. FANTASYONICE LIMITED, (U.S. CLS. 100, 101 AND 102). SN 79-089,398. PUB. 6-7-2011. FILED 10-19-2010.
 4,014,600 (*See Class 21 for this trademark.*)
 4,014,602. **ZOZOTOWN (STYLIZED)**. START TODAY CO., LTD., (U.S. CLS. 100, 101 AND 102). SN 79-090,207. PUB. 6-7-2011. FILED 7-30-2010.
 4,014,628 (*See Class 9 for this trademark.*)
 4,014,639 (*See Class 11 for this trademark.*)
 4,014,666 (*See Class 9 for this trademark.*)
 4,014,668 (*See Class 9 for this trademark.*)
 4,014,674. **PROSPEC, LLC AND DESIGN**. PRO TILE DISTRIBUTORS, INC., (U.S. CLS. 100, 101 AND 102). SN 85-012,504. PUB. 6-7-2011. FILED 4-13-2010.
 4,014,677 (*See Class 9 for this trademark.*)
 4,014,680. **BRIDGING DIMENSIONAL WITH DIGITAL (STANDARD CHARACTER)**. STRUCTURAL GRAPHICS, LLC, (U.S. CLS. 100, 101 AND 102). SN 85-019,020. PUB. 6-7-2011. FILED 4-21-2010.
 4,014,683. **THE OLIVE OIL HUNTER (STANDARD CHARACTER)**. FRESH PROCESSED OLIVE OIL, LLC, (U.S. CLS. 100, 101 AND 102). SN 85-023,936. PUB. 6-7-2011. FILED 4-27-2010.
 4,014,694. **INTERNATIONAL COUNCIL OF THIRTEEN INDIGENOUS GRANDMOTHERS (STANDARD CHARACTER)**. CENTER FOR SACRED STUDIES, ON BEHALF OF INTERNATIONAL COUNCIL OF THIRTEEN INDI-
 GENOUS GRANDMOTHERS, MULTIPLE CLASS, (INT. CLS. 35 AND 45), (U.S. CLS. 100, 101 AND 102). SN 85-033,558. PUB. 6-7-2011. FILED 5-7-2010.
 4,014,703. **LIFE INSURANCE AWARENESS MONTH (STANDARD CHARACTER)**. LIFE AND HEALTH INSURANCE FOUNDATION FOR EDUCATION, (U.S. CLS. 100, 101 AND 102). SN 85-038,559. PUB. 6-7-2011. FILED 5-14-2010.
 4,014,710 (*See Class 9 for this trademark.*)
 4,014,711 (*See Class 9 for this trademark.*)
 4,014,718. **50 50 100 (STANDARD CHARACTER)**. MELLI YELLOWPAGES, (U.S. CLS. 100, 101 AND 102). SN 85-047,323. PUB. 6-7-2011. FILED 5-25-2010.
 4,014,732. **ROYAL OAK STORAGE (STYLIZED)**. ROYAL OAK MINI STORAGE, LLC, DBA ROYAL OAK STORAGE, MULTIPLE CLASS, (INT. CLS. 35 AND 39), (U.S. CLS. 100, 101, 102 AND 105). SN 85-051,815. PUB. 6-7-2011. FILED 6-1-2010.
 4,014,737. **GREEN CITY MARKET (STANDARD CHARACTER)**. CHICAGO'S GREEN CITY MARKET PROGRAM, (U.S. CLS. 100, 101 AND 102). SN 85-053,629. PUB. 6-7-2011. FILED 6-3-2010.
 4,014,740 (*See Class 9 for this trademark.*)
 4,014,743. **ERIKSEN TRANSLATIONS (STANDARD CHARACTER)**. ERIKSEN TRANSLATIONS INC., MULTIPLE CLASS, (INT. CLS. 35 AND 41), (U.S. CLS. 100, 101, 102 AND 107). SN 85-056,031. PUB. 6-7-2011. FILED 6-7-2010.
 4,014,752. **WORK4 LABS (STANDARD CHARACTER)**. WORK4 LABS INC., MULTIPLE CLASS, (INT. CLS. 35 AND 42), (U.S. CLS. 100, 101 AND 102). SN 85-059,467. PUB. 6-7-2011. FILED 6-10-2010.
 4,014,760. **PA CHAMBER (STANDARD CHARACTER)**. PENNSYLVANIA CHAMBER OF BUSINESS AND INDUSTRY, (U.S. CLS. 100, 101 AND 102). SN 85-062,240. PUB. 6-7-2011. FILED 6-14-2010.
 4,014,764 (*See Class 9 for this trademark.*)
 4,014,773. **MAURICES SMALL TOWN SOUND (STANDARD CHARACTER)**. MAURICES INCORPORATED, (U.S. CLS. 100, 101 AND 102). SN 85-065,315. PUB. 6-7-2011. FILED 6-17-2010.
 4,014,774. **LOGIX GURU INTELLIGENT SOLUTIONS AND DESIGN**. LOGIX GURU LLC, DBA LOGIX GURU, MULTIPLE CLASS, (INT. CLS. 35 AND 42), (U.S. CLS. 100, 101 AND 102). SN 85-065,467. PUB. 6-7-2011. FILED 6-17-2010.
 4,014,779. **WORK FOR US (STANDARD CHARACTER)**. WORK4 LABS INC., MULTIPLE CLASS, (INT. CLS. 35 AND 42), (U.S. CLS. 100, 101 AND 102). SN 85-066,018. PUB. 6-7-2011. FILED 6-18-2010.
 4,014,780. **SUNSET FOODS (STANDARD CHARACTER)**. SUNSET FOOD MART, INC., DBA SUNSET FOODS, (U.S. CLS. 100, 101 AND 102). SN 85-066,223. PUB. 6-7-2011. FILED 6-18-2010.
 4,014,788 (*See Class 9 for this trademark.*)
 4,014,814. **I LUV BAND AND DESIGN**. BD PERFORMING ARTS, (U.S. CLS. 100, 101 AND 102). SN 85-074,821. PUB. 6-7-2011. FILED 6-30-2010.
 4,014,818. **SMITH ENTERPRISE, INC. (STANDARD CHARACTER)**. SMITH ENTERPRISE, INC., (U.S. CLS. 100, 101 AND 102). SN 85-075,333. PUB. 6-7-2011. FILED 6-30-2010.
 4,014,837. **ODLEAN AND DESIGN**. JOHNSON & JOHNSON, (U.S. CLS. 100, 101 AND 102). SN 85-078,103. PUB. 6-7-2011. FILED 7-6-2010.
 4,014,838. **ODLEAN (STANDARD CHARACTER)**. JOHNSON & JOHNSON, (U.S. CLS. 100, 101 AND 102). SN 85-078,104. PUB. 6-7-2011. FILED 7-6-2010.
 4,014,842. **POMA PROFESSIONAL OUTDOOR MEDIA ASSOCIATION AND DESIGN**. PROFESSIONAL OUTDOOR MEDIA ASSOCIATION, (U.S. CLS. 100, 101 AND 102). SN 85-079,460. PUB. 6-7-2011. FILED 7-7-2010.
 4,014,849 (*See Class 16 for this trademark.*)
 4,014,852. **IBILL (STANDARD CHARACTER)**. ALLSCRIPTS-MISYS HEALTHCARE SOLUTIONS, INC., (U.S. CLS. 100, 101 AND 102). SN 85-081,881. PUB. 6-7-2011. FILED 7-9-2010.
 4,014,857. **SEGUNDAMANO AND DESIGN**. ANUNTIS SEGUNDAMANO HOLDINGS, S.L., MULTIPLE CLASS, (INT. CLS. 35, 38 AND 42), (U.S. CLS. 100, 101, 102 AND 104). SN 85-082,375. PUB. 6-7-2011. FILED 7-12-2010.
 4,014,867. **WORTH MORE DEAD THAN ALIVE (STANDARD**

- CHARACTER**. AUI MANAGEMENT GROUP, INC., (U.S. CLS. 100, 101 AND 102). SN 85-085,596. PUB. 6-7-2011. FILED 7-15-2010.
- 4,014,882. **AMERICA'S PET STORE TO YOUR DOOR (STANDARD CHARACTER)**. MICHELE ABBUHL, MULTIPLE CLASS, (INT. CLS. 35 AND 39), (U.S. CLS. 100, 101, 102 AND 105). SN 85-088,378. PUB. 6-7-2011. FILED 7-20-2010.
- 4,014,887. **DELTA PHI LAMBDA (STANDARD CHARACTER)**. DELTA PHI LAMBDA SORORITY, INC., (U.S. CLS. 100, 101 AND 102). SN 85-089,227. PUB. 6-7-2011. FILED 7-21-2010.
- 4,014,891. **WALK TALL FOR LIFE (STANDARD CHARACTER)**. KYPHON SARL, (U.S. CLS. 100, 101 AND 102). SN 85-090,266. PUB. 6-7-2011. FILED 7-22-2010.
- 4,014,893. **MISCELLANEOUS DESIGN**. MICHELE ABBUHL, MULTIPLE CLASS, (INT. CLS. 35 AND 39), (U.S. CLS. 100, 101, 102 AND 105). SN 85-090,522. PUB. 6-7-2011. FILED 7-22-2010.
- 4,014,895. **MISCELLANEOUS DESIGN**. PCM ANIMATION STUDIOS, INC., MULTIPLE CLASS, (INT. CLS. 35 AND 41), (U.S. CLS. 100, 101, 102 AND 107). SN 85-091,248. PUB. 6-7-2011. FILED 7-23-2010.
- 4,014,909. **VELVET YOGURT (STANDARD CHARACTER)**. VELVET YOGURT, INC., (U.S. CLS. 100, 101 AND 102). SN 85-093,631. PUB. 6-7-2011. FILED 7-27-2010.
- 4,014,910. **EXPANSION MANAGEMENT GROUP (STANDARD CHARACTER)**. EXPANSION MANAGEMENT GROUP, LLC, MULTIPLE CLASS, (INT. CLS. 35 AND 36), (U.S. CLS. 100, 101 AND 102). SN 85-093,716. PUB. 6-7-2011. FILED 7-27-2010.
- 4,014,911. **GLOBAL SCRIPTURE IMPACT (STANDARD CHARACTER)**. AMERICAN BIBLE SOCIETY, (U.S. CLS. 100, 101 AND 102). SN 85-093,972. PUB. 6-7-2011. FILED 7-27-2010.
- 4,014,912 (*See Class 6 for this trademark*).
- 4,014,914. **IMPACT (STANDARD CHARACTER)**. AMERICAN BIBLE SOCIETY, (U.S. CLS. 100, 101 AND 102). SN 85-094,049. PUB. 6-7-2011. FILED 7-27-2010.
- 4,014,916. **ECOLAB (STANDARD CHARACTER)**. ECOLAB USA INC., (U.S. CLS. 100, 101 AND 102). SN 85-094,685. PUB. 5-3-2011. FILED 7-28-2010.
- 4,014,918. **LET FANDOM RING (STANDARD CHARACTER)**. COLHOC LIMITED PARTNERSHIP, DBA COLUMBUS BLUE JACKETS, (U.S. CLS. 100, 101 AND 102). SN 85-094,807. PUB. 6-7-2011. FILED 7-28-2010.
- 4,014,922 (*See Class 16 for this trademark*).
- 4,014,935. **BUTCH BAKERY AND DESIGN**. BUTCH BAKERY LLC, (U.S. CLS. 100, 101 AND 102). SN 85-098,721. PUB. 6-7-2011. FILED 8-3-2010.
- 4,014,943. **AVA ALLIANCE OF VISUAL ARTISTS AND DESIGN**. ALLIANCE OF VISUAL ARTISTS, (U.S. CLS. 100, 101 AND 102). SN 85-100,751. PUB. 6-7-2011. FILED 8-5-2010.
- 4,014,949. **CSCS CENTRALIZED SUPPLY CHAIN SERVICES, LLC (STYLIZED)**. CENTRALIZED SUPPLY CHAIN SERVICES, LLC, (U.S. CLS. 100, 101 AND 102). SN 85-101,929. PUB. 6-7-2011. FILED 8-6-2010.
- 4,014,950. **MISCELLANEOUS DESIGN**. SOMEDIA SOLUTIONS, INC., (U.S. CLS. 100, 101 AND 102). SN 85-103,003. PUB. 6-7-2011. FILED 8-9-2010.
- 4,014,954. **GIBBS DELTA AND DESIGN**. GIBBS-NORTAC INDUSTRIES LTD., (U.S. CLS. 100, 101 AND 102). SN 85-103,556. PUB. 6-7-2011. FILED 8-9-2010.
- 4,014,955. **PLATINUM SERVICE (STANDARD CHARACTER)**. THE GOODMAN GROUP, LLC, DBA THE GOODMAN GROUP, (U.S. CLS. 100, 101 AND 102). SN 85-103,784. PUB. 6-7-2011. FILED 8-10-2010.
- 4,014,956. **THE GOODMAN GROUP PLATINUM SERVICE ENVISIONING THE FUTURE G AND DESIGN**. THE GOODMAN GROUP, LLC, DBA THE GOODMAN GROUP, (U.S. CLS. 100, 101 AND 102). SN 85-103,989. PUB. 6-7-2011. FILED 8-10-2010.
- 4,014,957. **ST. AUGUSTINE LIGHTHOUSE (STANDARD CHARACTER)**. THE SAINT AUGUSTINE LIGHTHOUSE AND MUSEUM, INC., (U.S. CLS. 100, 101 AND 102). SN 85-104,165. PUB. 6-7-2011. FILED 8-10-2010.
- 4,014,958 (*See Class 25 for this trademark*).
- 4,014,960. **C CALIBER AND DESIGN**. DAYMON INTERACTIONS INC., (U.S. CLS. 100, 101 AND 102). SN 85-104,455. PUB. 6-7-2011. FILED 8-10-2010.
- 4,014,963. **THE BEEF JERKY OUTLET AND DESIGN**. THE BEEF JERKY OUTLET FRANCHISE, INC., (U.S. CLS. 100, 101 AND 102). SN 85-105,270. PUB. 6-7-2011. FILED 8-11-2010.
- 4,014,965. **JUST WHAT YOU'RE LOOKING FOR! (STANDARD CHARACTER)**. MEALEY'S FURNITURE HOLDINGS, INC., (U.S. CLS. 100, 101 AND 102). SN 85-105,385. PUB. 6-7-2011. FILED 8-11-2010.
- 4,014,972. **NEW HORIZONS MAPPING YOUR LIFE OPTIONS AND DESIGN**. CAREER PARTNERS INTERNATIONAL LLC, (U.S. CLS. 100, 101 AND 102). SN 85-108,180. PUB. 6-7-2011. FILED 8-16-2010.
- 4,014,977. **JLOFTS ON THE MARKET (STANDARD CHARACTER)**. 1308 JACKSON DEV, LLC, MULTIPLE CLASS, (INT. CLS. 35, 36 AND 37), (U.S. CLS. 100, 101, 102, 103 AND 106). SN 85-110,565. PUB. 6-7-2011. FILED 8-18-2010.
- 4,014,982. **24 SEVEN (STANDARD CHARACTER)**. 24 SEVEN INC., (U.S. CLS. 100, 101 AND 102). SN 85-114,278. PUB. 6-7-2011. FILED 8-24-2010.
- 4,014,990 (*See Class 21 for this trademark*).
- 4,014,993. **DELVEPOINT (STANDARD CHARACTER)**. UDT GROUP, LLC, MULTIPLE CLASS, (INT. CLS. 35, 42 AND 45), (U.S. CLS. 100, 101 AND 102). SN 85-118,875. PUB. 6-7-2011. FILED 8-30-2010.
- 4,015,002. **THE IRS PROBLEM SOLVERS (STANDARD CHARACTER)**. EVAN BRODY, MULTIPLE CLASS, (INT. CLS. 35 AND 42), (U.S. CLS. 100, 101 AND 102). SN 85-120,942. PUB. 6-7-2011. FILED 9-1-2010.
- 4,015,013. **HOLISTIC VANITY (STANDARD CHARACTER)**. PURE + SIMPLE BEAUTY INCORPORATED, (U.S. CLS. 100, 101 AND 102). SN 85-121,799. PUB. 6-7-2011. FILED 9-2-2010.
- 4,015,018. **AUTOGOOGO (STANDARD CHARACTER)**. JOSEPH L. ASHTON, (U.S. CLS. 100, 101 AND 102). SN 85-123,091. PUB. 3-1-2011. FILED 9-3-2010.
- 4,015,026. **IGUANA ISLE AND DESIGN**. SANDCASTLE HOSPITALITY INCORPORATED, (U.S. CLS. 100, 101 AND 102). SN 85-125,433. PUB. 3-1-2011. FILED 9-8-2010.
- 4,015,038. **STUFFED ARTISAN CANNOLIS AND DESIGN**. ANTHONY FONTANA, AND BRIELLE DAHAN, (U.S. CLS. 100, 101 AND 102). SN 85-128,960. PUB. 6-7-2011. FILED 9-14-2010.
- 4,015,042. **POSH PALACE AND DESIGN**. POSH PALACE, (U.S. CLS. 100, 101 AND 102). SN 85-129,556. PUB. 6-7-2011. FILED 9-14-2010.
- 4,015,044. **HUNTSVILLE THE SKY IS NOT THE LIMIT AND DESIGN**. CHAMBER OF COMMERCE OF HUNTSVILLE/MADISON COUNTY, INC., (U.S. CLS. 100, 101 AND 102). SN 85-130,405. PUB. 6-7-2011. FILED 9-15-2010.
- 4,015,047. **MY IDENTITY (STANDARD CHARACTER)**. GLOBAL MEDICAL DIRECTORY, (U.S. CLS. 100, 101 AND 102). SN 85-131,108. PUB. 6-7-2011. FILED 9-16-2010.
- 4,015,049. **6 AND DESIGN**. ZAPPOS IP, INC., (U.S. CLS. 100, 101 AND 102). SN 85-131,492. PUB. 6-7-2011. FILED 9-16-2010.
- 4,015,053. **LONDON CONSULTING GROUP GET MORE FROM YOUR BUSINESS AND DESIGN**. LONDON CONSULTING GROUP, INC., DBA LONDON CONSULTING GROUP, (U.S. CLS. 100, 101 AND 102). SN 85-134,915. PUB. 6-7-2011. FILED 9-21-2010.
- 4,015,055. **L O N D O N BUSINESS SERVICES GET MORE FROM YOUR BUSINESS AND DESIGN**. LONDON CONSULTING GROUP, INC., DBA LONDON CONSULTING GROUP, (U.S. CLS. 100, 101 AND 102). SN 85-135,383. PUB. 6-7-2011. FILED 9-22-2010.
- 4,015,060. **WILLIAMS-SONOMA RESERVE (STANDARD CHARACTER)**. WILLIAMS-SONOMA, INC., MULTIPLE CLASS, (INT. CLS. 35 AND 39), (U.S. CLS. 100, 101, 102 AND 105). SN 85-136,969. PUB. 6-7-2011. FILED 9-23-2010.
- 4,015,064. **MT MUSEUM TOWER AND DESIGN**. MUSEUM TOWER, LP, (U.S. CLS. 100, 101 AND 102). SN 85-137,578. PUB. 6-7-2011. FILED 9-24-2010.
- 4,015,066. **SAVE MONEY. SLEEP HAPPY (STANDARD CHARACTER)**. MATTRESS FIRM, INC., (U.S. CLS. 100, 101 AND 102). SN 85-138,032. PUB. 6-7-2011. FILED 9-24-2010.
- 4,015,070 (*See Class 14 for this trademark*).

- 4,015,075. **BOASTINGBIZ AND DESIGN**. BOASTING BIZ, INC., MULTIPLE CLASS, (INT. CLS. 35 AND 42), (U.S. CLS. 100, 101 AND 102). SN 85-140,330. PUB. 6-7-2011. FILED 9-28-2010.
- 4,015,079. **FLIGHTSURANCE AND DESIGN**. FLIGHTSURANCE GMBH, MULTIPLE CLASS, (INT. CLS. 35 AND 36), (U.S. CLS. 100, 101 AND 102). SN 85-141,641. PUB. 6-7-2011. FILED 9-30-2010.
- 4,015,083. **LEA'S (STYLIZED)**. LE, SON D, (U.S. CLS. 100, 101 AND 102). SN 85-142,522. PUB. 6-7-2011. FILED 9-30-2010.
- 4,015,091. **INNOVATIVE IDM (STANDARD CHARACTER)**. INNOVATIVE AUTOMATION, INC., (U.S. CLS. 100, 101 AND 102). SN 85-144,203. PUB. 6-7-2011. FILED 10-4-2010.
- 4,015,098. **CLICKTHECOUP.COM IN-TOWN ONLINE STEALS & DEALS AND DESIGN**. MCCLENATHAN, STACEY LIESA, DBA CLICKTHECOUP.COM, (U.S. CLS. 100, 101 AND 102). SN 85-147,219. PUB. 6-7-2011. FILED 10-7-2010.
- 4,015,100. **THE JOY OF HANDSPINNING AND DESIGN**. ZIMMER, TULASI, DBA THE JOY OF HANDSPINNING, (U.S. CLS. 100, 101 AND 102). SN 85-147,985. PUB. 6-7-2011. FILED 10-7-2010.
- 4,015,106. **MGID (STANDARD CHARACTER)**. MARKETGID USA, INC., (U.S. CLS. 100, 101 AND 102). SN 85-149,678. PUB. 3-1-2011. FILED 10-11-2010.
- 4,015,111. **GEORGETOWN FRAME SHOPPE (STANDARD CHARACTER)**. PETER BORTZ, PRESIDENT, DBA GEORGETOWN FRAME SHOPPE, MULTIPLE CLASS, (INT. CLS. 35, 36, 37 AND 40), (U.S. CLS. 100, 101, 102, 103 AND 106). SN 85-150,453. PUB. 6-7-2011. FILED 10-12-2010.
- 4,015,112. **JK DESIGN AND DESIGN**. JK DESIGN, (U.S. CLS. 100, 101 AND 102). SN 85-150,495. PUB. 6-7-2011. FILED 10-12-2010.
- 4,015,124. **DIO COLLECTIONS (STANDARD CHARACTER)**. ERIKATY, LLC, (U.S. CLS. 100, 101 AND 102). SN 85-155,044. PUB. 6-7-2011. FILED 10-18-2010.
- 4,015,130. **FRONT CENTER MEDIA (STANDARD CHARACTER)**. 1 TO 1 MEDIA GROUP, LLC, (U.S. CLS. 100, 101 AND 102). SN 85-157,636. PUB. 6-7-2011. FILED 10-21-2010.
- 4,015,170. **WELCOME TO ARKANSAS (STANDARD CHARACTER)**. ARKANSAS TOURISM DEVELOPMENT FOUNDATION, INC., (U.S. CLS. 100, 101 AND 102). SN 85-169,080. PUB. 6-7-2011. FILED 11-4-2010.
- 4,015,172. **EXECUTECH LEASE GROUP AND DESIGN**. EXECUTECH LEASE GROUP, (U.S. CLS. 100, 101 AND 102). SN 85-170,127. PUB. 6-7-2011. FILED 11-5-2010.
- 4,015,177. **SOIX (STANDARD CHARACTER)**. SMA INFORMATICS PARTNERS LLC, DBA SURGICAL OUTCOMES INFORMATION EXCHANGE, (U.S. CLS. 100, 101 AND 102). SN 85-171,211. PUB. 6-7-2011. FILED 11-8-2010.
- 4,015,179. **FLORIDAYS RESORT (STANDARD CHARACTER)**. FLORIDAYS RESORT MANAGEMENT CO., LLC, MULTIPLE CLASS, (INT. CLS. 35, 36 AND 37), (U.S. CLS. 100, 101, 102, 103 AND 106). SN 85-171,872. PUB. 6-7-2011. FILED 11-8-2010.
- 4,015,180. **FLORIDAYS RESORT ORLANDO AND DESIGN**. FLORIDAYS RESORT MANAGEMENT CO., LLC, MULTIPLE CLASS, (INT. CLS. 35, 36 AND 37), (U.S. CLS. 100, 101, 102, 103 AND 106). SN 85-171,911. PUB. 6-7-2011. FILED 11-8-2010.
- 4,015,181. **AUCT!ON.COM (STYLIZED)**. AUCTION.COM, LLC, (U.S. CLS. 100, 101 AND 102). SN 85-172,010. PUB. 6-7-2011. FILED 11-8-2010.
- 4,015,185. **P3 AND DESIGN**. THE R.D. ROGERS COMPANY, MULTIPLE CLASS, (INT. CLS. 35, 37 AND 42), (U.S. CLS. 100, 101, 102, 103 AND 106). SN 85-174,243. PUB. 6-7-2011. FILED 11-11-2010.
- 4,015,188. **THERIGY (STANDARD CHARACTER)**. THERIGY, LLC, MULTIPLE CLASS, (INT. CLS. 35, 42 AND 44), (U.S. CLS. 100, 101 AND 102). SN 85-174,827. PUB. 6-7-2011. FILED 11-11-2010.
- 4,015,192. **THERIGY IMPROVING THERAPY . ENHANCING LIVES AND DESIGN**. THERIGY, LLC, MULTIPLE CLASS, (INT. CLS. 35, 42 AND 44), (U.S. CLS. 100, 101 AND 102). SN 85-175,779. PUB. 6-7-2011. FILED 11-12-2010.
- 4,015,195. **RENTINO RIO (STANDARD CHARACTER)**. RENTINO CORPORATION, (U.S. CLS. 100, 101 AND 102). SN 85-176,640. PUB. 6-7-2011. FILED 11-15-2010.
- 4,015,196. **COMPLIANCEMETRIX (STANDARD CHARACTER)**. REQUIREMENTSLIVE LLC, MULTIPLE CLASS, (INT. CLS. 35 AND 42), (U.S. CLS. 100, 101 AND 102). SN 85-177,145. PUB. 6-7-2011. FILED 11-15-2010.
- 4,015,202. **US GTF UNITED STATES GOLF TEACHERS FEDERATION AND DESIGN**. THE FLORIDA GOLF SCHOOL, INC., DBA UNITED STATES GOLF TEACHERS FEDERATION, MULTIPLE CLASS, (INT. CLS. 35, 41 AND 42), (U.S. CLS. 100, 101, 102 AND 107). SN 85-177,922. PUB. 6-7-2011. FILED 11-16-2010.
- 4,015,213. **HOME AMERICA (STANDARD CHARACTER)**. BRICKELL FINANCIAL SERVICES-MOTOR CLUB, INC., MULTIPLE CLASS, (INT. CLS. 35, 36, 37, 39 AND 45), (U.S. CLS. 100, 101, 102, 103, 105 AND 106). SN 85-181,794. PUB. 6-7-2011. FILED 11-20-2010.
- 4,015,218. **AHEC SOUTHWESTERN CONNECTICUT AND DESIGN**. SOUTHWESTERN AHEC, INC., MULTIPLE CLASS, (INT. CLS. 35 AND 41), (U.S. CLS. 100, 101, 102 AND 107). SN 85-183,385. PUB. 6-7-2011. FILED 11-23-2010.
- 4,015,219. **POETA (STANDARD CHARACTER)**. THE TRUST FOR THE AMERICAS, MULTIPLE CLASS, (INT. CLS. 35, 41 AND 42), (U.S. CLS. 100, 101, 102 AND 107). SN 85-183,680. PUB. 6-7-2011. FILED 11-23-2010.
- 4,015,224. **FIRST TENNESSEE CASH REWARDS (STANDARD CHARACTER)**. FIRST HORIZON NATIONAL CORPORATION, MULTIPLE CLASS, (INT. CLS. 35 AND 36), (U.S. CLS. 100, 101 AND 102). SN 85-184,630. PUB. 6-7-2011. FILED 11-24-2010.
- 4,015,227. **AUTOBOOK NOW (STANDARD CHARACTER)**. AUTOBOOK NOW LLC, (U.S. CLS. 100, 101 AND 102). SN 85-185,256. PUB. 6-7-2011. FILED 11-25-2010.
- 4,015,230. **SPOKES ETC. BICYCLES BEST WHEELS GOIN' AROUND AND DESIGN**. SPOKES ETC., INC., (U.S. CLS. 100, 101 AND 102). SN 85-186,094. PUB. 6-7-2011. FILED 11-29-2010.
- 4,015,233. **MI LLAVE (STANDARD CHARACTER)**. THE TRUST FOR THE AMERICAS, MULTIPLE CLASS, (INT. CLS. 35, 41 AND 42), (U.S. CLS. 100, 101, 102 AND 107). SN 85-186,539. PUB. 6-7-2011. FILED 11-29-2010.
- 4,015,234. **AMERICAN EAGLE OUTFITTERS (STANDARD CHARACTER)**. RETAIL ROYALTY COMPANY, (U.S. CLS. 100, 101 AND 102). SN 85-187,565. PUB. 6-7-2011. FILED 11-30-2010.
- 4,015,247. **ANIMAL GEEKS.COM (STANDARD CHARACTER)**. MARINE GEEK, INC., MULTIPLE CLASS, (INT. CLS. 35, 38 AND 41), (U.S. CLS. 100, 101, 102, 104 AND 107). SN 85-190,024. PUB. 6-7-2011. FILED 12-3-2010.
- 4,015,255. **NEIGHBORHOOD DIRECT (STANDARD CHARACTER)**. X-4 MEDIA, INC., DBA NEIGHBORHOOD DIRECT, (U.S. CLS. 100, 101 AND 102). SN 85-192,777. PUB. 6-7-2011. FILED 12-8-2010.
- 4,015,258. **ASBURY PARK WHERE MUSIC LIVES (STANDARD CHARACTER)**. ASBURY PARK ZONE DEVELOPMENT CORP., MULTIPLE CLASS, (INT. CLS. 35 AND 41), (U.S. CLS. 100, 101, 102 AND 107). SN 85-193,338. PUB. 6-7-2011. FILED 12-8-2010.
- 4,015,260. **MISCELLANEOUS DESIGN**. ALLSTATE INSURANCE COMPANY, MULTIPLE CLASS, (INT. CLS. 35, 36, 37 AND 39), (U.S. CLS. 100, 101, 102, 103, 105 AND 106). SN 85-194,458. PUB. 6-7-2011. FILED 12-9-2010.
- 4,015,270. **ECONOHEALTH ROI (STANDARD CHARACTER)**. CHENOWETH & ASSOCIATES, INC., DBA HEALTH MANAGEMENT ASSOCIATES, (U.S. CLS. 100, 101 AND 102). SN 85-195,997. PUB. 6-7-2011. FILED 12-12-2010.
- 4,015,272. **P A L A Z Z I FLORENCE ASSOCIATION FOR INTERNATIONAL EDUCATION AND DESIGN**. CONSORZIO PALAZZI - FLORENCE ASSOCIATION FOR INTERNATIONAL EDUCATION, (U.S. CLS. 100, 101 AND 102). SN 85-196,318. PUB. 6-7-2011. FILED 12-13-2010.
- 4,015,276. **X8 SOLUTIONS AND DESIGN**. X8 SOLUTIONS, INC., DBA X8, (U.S. CLS. 100, 101 AND 102). SN 85-196,649. PUB. 6-7-2011. FILED 12-13-2010.
- 4,015,277. **SMALL BUSINESS TRENDS (STANDARD CHARACTER)**. SMALL BUSINESS TRENDS LLC, MULTIPLE CLASS, (INT. CLS. 35 AND 41), (U.S. CLS. 100, 101, 102 AND 107). SN 85-196,703. PUB. 6-7-2011. FILED 12-13-2010.
- 4,015,291. **EXIST! ONLINE! (STYLIZED)**. REDSEEB, INC., (U.S. CLS. 100, 101 AND 102). SN 85-198,851. PUB. 6-7-2011.

- FILED 12-15-2010.
- 4,015,297. **HOME PERFORMANCE ROADMAP (STANDARD CHARACTER)**. IMAGINE ENERGY, LLC, (U.S. CLS. 100, 101 AND 102). SN 85-200,025. PUB. 6-7-2011. FILED 12-16-2010.
- 4,015,303. **GORE MOUNTAIN REGION PURELY ADIRONDACK (STANDARD CHARACTER)**. NORTH CREEK CHAMBER OF COMMERCE, (U.S. CLS. 100, 101 AND 102). SN 85-200,546. PUB. 6-7-2011. FILED 12-17-2010.
- 4,015,311. **CANDYCONNECTION AND DESIGN**. SEVIGNY, ROGER, (U.S. CLS. 100, 101 AND 102). SN 85-202,008. PUB. 6-7-2011. FILED 12-20-2010.
- 4,015,312 (*See Class 30 for this trademark*).
- 4,015,314. **ADEPT FASTENERS AND DESIGN**. ADEPT FASTENERS, (U.S. CLS. 100, 101 AND 102). SN 85-202,261. PUB. 6-7-2011. FILED 12-20-2010.
- 4,015,328. **LEVERAGE2MARKET (STANDARD CHARACTER)**. L2M ASSOCIATES, INC., MULTIPLE CLASS, (INT. CLS. 35 AND 41), (U.S. CLS. 100, 101, 102 AND 107). SN 85-203,468. PUB. 6-7-2011. FILED 12-21-2010.
- 4,015,329. **NIA NUTRITION INDUSTRY ASSOCIATION WEST AND DESIGN**. NUTRITION INDUSTRY ASSOCIATION WEST, (U.S. CLS. 100, 101 AND 102). SN 85-204,053. PUB. 6-7-2011. FILED 12-22-2010.
- 4,015,334. **UNAVCO AND DESIGN**. UNAVCO, INC., MULTIPLE CLASS, (INT. CLS. 35, 37, 41 AND 42), (U.S. CLS. 100, 101, 102, 103, 106 AND 107). SN 85-204,879. PUB. 6-7-2011. FILED 12-23-2010.
- 4,015,342. **SURGERE PERFECT YOUR SUPPLY CHAIN AND DESIGN**. SURGERE, INC., (U.S. CLS. 100, 101 AND 102). SN 85-206,491. PUB. 6-7-2011. FILED 12-28-2010.
- 4,015,343. **THE PERFECT SCALE (STANDARD CHARACTER)**. BOWLINGBALL.COM, INC., (U.S. CLS. 100, 101 AND 102). SN 85-206,545. PUB. 6-7-2011. FILED 12-28-2010.
- 4,015,344. **MOO MOO'S YOGURT BAR AND DESIGN**. MOO-MOO'S YOGURT BAR, INC., (U.S. CLS. 100, 101 AND 102). SN 85-206,618. PUB. 6-7-2011. FILED 12-28-2010.
- 4,015,351 (*See Class 18 for this trademark*).
- 4,015,353 (*See Class 18 for this trademark*).
- 4,015,361. **WINES & MORE MANSFIELD (STANDARD CHARACTER)**. WINE & SPIRITS RETAIL CONSULTANTS INC., (U.S. CLS. 100, 101 AND 102). SN 85-208,957. PUB. 6-7-2011. FILED 1-3-2011.
- 4,015,367. **THE SALES IMAGE (STANDARD CHARACTER)**. THE SALES PITCH, LLC, MULTIPLE CLASS, (INT. CLS. 35 AND 42), (U.S. CLS. 100, 101 AND 102). SN 85-209,326. PUB. 6-7-2011. FILED 1-3-2011.
- 4,015,371. **INSTOCK & BEYOND (STANDARD CHARACTER)**. RUBIN, I SAMSON, (U.S. CLS. 100, 101 AND 102). SN 85-209,617. PUB. 6-7-2011. FILED 1-4-2011.
- 4,015,376. **FLATHEADLAKECHERRYGROWERS AND DESIGN**. FLATHEAD LAKE CHERRY GROWERS, INC., (U.S. CLS. 100, 101 AND 102). SN 85-210,429. PUB. 6-7-2011. FILED 1-4-2011.
- 4,015,379. **ATRINSIC MEDIA FOR WHAT'S NEXT AND DESIGN**. ATRINSIC, INC., MULTIPLE CLASS, (INT. CLS. 35 AND 42), (U.S. CLS. 100, 101 AND 102). SN 85-210,965. PUB. 6-7-2011. FILED 1-5-2011.
- 4,015,390. **EDGAR AND DESIGN**. GOODWILL INDUSTRIES OF THE VALLEYS, INC., MULTIPLE CLASS, (INT. CLS. 35 AND 36), (U.S. CLS. 100, 101 AND 102). SN 85-212,222. PUB. 6-7-2011. FILED 1-6-2011.
- 4,015,391. **THEFUTUREOFREPLACEMENTWINDOWS.COM (STANDARD CHARACTER)**. WINDOW UNIVERSE, MULTIPLE CLASS, (INT. CLS. 35 AND 37), (U.S. CLS. 100, 101, 102, 103 AND 106). SN 85-212,241. PUB. 6-7-2011. FILED 1-6-2011.
- 4,015,392. **STRATEGY BIT (STANDARD CHARACTER)**. STRATEGY BIT CONSULTING LLC, (U.S. CLS. 100, 101 AND 102). SN 85-212,362. PUB. 6-7-2011. FILED 1-6-2011.
- 4,015,395. **THE PUBLIC SOCIETY PS (STYLIZED)**. FLEMING, CRISTIAN R, DBA THE PUBLIC SOCIETY, (U.S. CLS. 100, 101 AND 102). SN 85-212,652. PUB. 6-7-2011. FILED 1-7-2011.
- 4,015,406. **A ALBUMS INCORPORATED AND DESIGN**. ALBUMS INC., (U.S. CLS. 100, 101 AND 102). SN 85-213,829. PUB. 6-7-2011. FILED 1-10-2011.
- 4,015,412. **EMPLOYEE ENGAGEMENT EMPORIUM (STANDARD CHARACTER)**. HR SOLUTIONS, INC., (U.S. CLS. 100, 101 AND 102). SN 85-214,197. PUB. 6-7-2011. FILED 1-10-2011.
- 4,015,413. **BOOTS TO SHOES (STANDARD CHARACTER)**. BOOTS TO SHOES FOUNDATION, (U.S. CLS. 100, 101 AND 102). SN 85-214,388. PUB. 6-7-2011. FILED 1-10-2011.
- 4,015,414. **BOOTS TO SHOES FOUNDATION (STANDARD CHARACTER)**. BOOTS TO SHOES FOUNDATION, (U.S. CLS. 100, 101 AND 102). SN 85-214,412. PUB. 6-7-2011. FILED 1-10-2011.
- 4,015,416. **BLUECLOUD (STANDARD CHARACTER)**. BLUE CLOUD COMMUNICATIONS, INC., MULTIPLE CLASS, (INT. CLS. 35 AND 42), (U.S. CLS. 100, 101 AND 102). SN 85-214,553. PUB. 6-7-2011. FILED 1-10-2011.
- 4,015,423. **HELPING 21ST CENTURY VETERANS CAPTURE 21ST CENTURY JOBS (STANDARD CHARACTER)**. BOOTS TO SHOES FOUNDATION, (U.S. CLS. 100, 101 AND 102). SN 85-214,822. PUB. 6-7-2011. FILED 1-11-2011.
- 4,015,426. **FLOORING DALTON DIRECT CENTER AND DESIGN**. MCAF LLC, (U.S. CLS. 100, 101 AND 102). SN 85-215,109. PUB. 6-7-2011. FILED 1-11-2011.
- 4,015,438. **PURCHASE PARTY (STANDARD CHARACTER)**. PURCHASEPARTY, LLC, (U.S. CLS. 100, 101 AND 102). SN 85-216,165. PUB. 6-7-2011. FILED 1-12-2011.
- 4,015,440. **PURCHASEPARTY.COM SALE YOU CAN'T AFFORD TO MISS THIS PARTY! AND DESIGN**. PURCHASEPARTY, LLC, (U.S. CLS. 100, 101 AND 102). SN 85-216,200. PUB. 6-7-2011. FILED 1-12-2011.
- 4,015,441. **NATIONAL GIRLS COLLABORATIVE PROJECT (STANDARD CHARACTER)**. EDLAB GROUP FOUNDATION, DBA EDLAB GROUP, (U.S. CLS. 100, 101 AND 102). SN 85-216,375. PUB. 6-7-2011. FILED 1-12-2011.
- 4,015,443. **LIKOSH (STANDARD CHARACTER)**. TOBIN, ELENA, (U.S. CLS. 100, 101 AND 102). SN 85-216,558. PUB. 6-7-2011. FILED 1-13-2011.
- 4,015,445. **GOOD NEIGHBOR BONUS BANKING (STANDARD CHARACTER)**. STATE FARM MUTUAL AUTOMOBILE INSURANCE COMPANY, (U.S. CLS. 100, 101 AND 102). SN 85-216,742. PUB. 6-7-2011. FILED 1-13-2011.
- 4,015,449. **PAPERSTATS (STANDARD CHARACTER)**. PUGGET INC, (U.S. CLS. 100, 101 AND 102). SN 85-216,949. PUB. 6-7-2011. FILED 1-13-2011.
- 4,015,451. **BLAZING FEEDBACK (STANDARD CHARACTER)**. TIMELY CONTACT, INC., (U.S. CLS. 100, 101 AND 102). SN 85-217,003. PUB. 6-7-2011. FILED 1-13-2011.
- 4,015,452 (*See Class 3 for this trademark*).
- 4,015,456. **DEALNATION (STANDARD CHARACTER)**. DEALNATION, INC, (U.S. CLS. 100, 101 AND 102). SN 85-217,212. PUB. 6-7-2011. FILED 1-13-2011.
- 4,015,467. **THE NEXT LEVEL AND DESIGN**. GEMMA, ANTHONY, MULTIPLE CLASS, (INT. CLS. 35 AND 41), (U.S. CLS. 100, 101, 102 AND 107). SN 85-217,857. PUB. 6-7-2011. FILED 1-14-2011.
- 4,015,468. **ROYALTY IDEAS (STYLIZED)**. ROYALTY, MARSHALL, (U.S. CLS. 100, 101 AND 102). SN 85-217,868. PUB. 6-7-2011. FILED 1-14-2011.
- 4,015,475. **CAROLINA WEST WIRELESS (STANDARD CHARACTER)**. CAROLINA WEST WIRELESS, INC., MULTIPLE CLASS, (INT. CLS. 35 AND 38), (U.S. CLS. 100, 101, 102 AND 104). SN 85-218,148. PUB. 6-7-2011. FILED 1-14-2011.
- 4,015,481. **MYROI (STANDARD CHARACTER)**. MEETING-METRICS, INC., (U.S. CLS. 100, 101 AND 102). SN 85-218,605. PUB. 6-7-2011. FILED 1-15-2011.
- 4,015,485. **KNOWLEDGE ORE (STANDARD CHARACTER)**. AYALA, HANA, (U.S. CLS. 100, 101 AND 102). SN 85-218,725. PUB. 6-7-2011. FILED 1-15-2011.
- 4,015,486. **BLUE IVY AND DESIGN**. BLUE IVY LLC, (U.S. CLS. 100, 101 AND 102). SN 85-218,802. PUB. 6-7-2011. FILED 1-16-2011.
- 4,015,492. **D AND DESIGN**. DAHDOUL TEXTILES, (U.S. CLS. 100, 101 AND 102). SN 85-218,931. PUB. 6-7-2011. FILED 1-17-2011.
- 4,015,495 (*See Class 30 for this trademark*).
- 4,015,501 (*See Class 16 for this trademark*).
- 4,015,508. **AARDVARK MEDICAL SALES (STANDARD CHARACTER)**. AARDVARK MEDICAL SALES, INC., (U.S. CLS. 100, 101 AND 102). SN 85-219,557. PUB. 6-7-2011. FILED 1-18-2011.

- 4,015,509. **FIND FORM FUND (STANDARD CHARACTER)**. MARCO RUBIN, MULTIPLE CLASS, (INT. CLS. 35 AND 36), (U.S. CLS. 100, 101 AND 102). SN 85-219,568. PUB. 6-7-2011. FILED 1-18-2011.
- 4,015,518. **IMPACT TEEN DRIVERS (STANDARD CHARACTER)**. IMPACT TEEN DRIVERS FUND, (U.S. CLS. 100, 101 AND 102). SN 85-219,753. PUB. 6-7-2011. FILED 1-18-2011.
- 4,015,519. **DHARMA PARTYS (STANDARD CHARACTER)**. DAVID MUNSTERMAN, (U.S. CLS. 100, 101 AND 102). SN 85-219,857. PUB. 6-7-2011. FILED 1-18-2011.
- 4,015,523. **HARRIS COUNTY CRIMINAL LAWYERS ASSOCIATION EST. 1970 AND DESIGN**. HARRIS COUNTY CRIMINAL LAWYERS ASSOCIATION, AKA HCCLA, (U.S. CLS. 100, 101 AND 102). SN 85-219,942. PUB. 6-7-2011. FILED 1-18-2011.
- 4,015,535. **N NOLLETTE FINANCIAL AND DESIGN**. NOLLETTE, SKYLER B., DBA NOLLETTE FINANCIAL, MULTIPLE CLASS, (INT. CLS. 35 AND 36), (U.S. CLS. 100, 101 AND 102). SN 85-220,399. PUB. 6-7-2011. FILED 1-18-2011.
- 4,015,539. **FUNDRAISING FAVORITES (STANDARD CHARACTER)**. CHAVEY VENTURES, INC., (U.S. CLS. 100, 101 AND 102). SN 85-220,718. PUB. 6-7-2011. FILED 1-19-2011.
- 4,015,541. **STYLE.LICIOUS (STANDARD CHARACTER)**. STYLE.LICIOUS LLC, (U.S. CLS. 100, 101 AND 102). SN 85-220,727. PUB. 6-7-2011. FILED 1-19-2011.
- 4,015,544. **INDIEFLIX (STANDARD CHARACTER)**. INDIEFLIX, INC., (U.S. CLS. 100, 101 AND 102). SN 85-220,782. PUB. 6-7-2011. FILED 1-19-2011.
- 4,015,547 (*See Class 25 for this trademark*).
- 4,015,549. **LE DOM HAIR & BEAUTY BOUTIQUE AND DESIGN**. LE DOM HAIR & BEAUTY BOUTIQUE, (U.S. CLS. 100, 101 AND 102). SN 85-220,909. PUB. 6-7-2011. FILED 1-19-2011.
- 4,015,554. **DO WHAT YOU DO BEST, LET US HANDLE THE REST! (STANDARD CHARACTER)**. TREND PERSONNEL SERVICES, (U.S. CLS. 100, 101 AND 102). SN 85-220,965. PUB. 6-7-2011. FILED 1-19-2011.
- 4,015,558. **CLIA AND DESIGN**. CRUISE LINES INTERNATIONAL ASSOCIATION, INC., (U.S. CLS. 100, 101 AND 102). SN 85-221,039. PUB. 6-7-2011. FILED 1-19-2011.
- 4,015,562. **CLIA (STANDARD CHARACTER)**. CRUISE LINES INTERNATIONAL ASSOCIATION, INC., (U.S. CLS. 100, 101 AND 102). SN 85-221,072. PUB. 6-7-2011. FILED 1-19-2011.
- 4,015,564. **SERVAL & ASSOCIÉS (STANDARD CHARACTER)**. SERVAL & ASSOCIÉS, (U.S. CLS. 100, 101 AND 102). SN 85-221,200. PUB. 6-7-2011. FILED 1-19-2011.
- 4,015,572 (*See Class 30 for this trademark*).
- 4,015,579. **FERNDALE HEALTHCARE INC AND DESIGN**. FERNDALE IP, INC., (U.S. CLS. 100, 101 AND 102). SN 85-221,549. PUB. 6-7-2011. FILED 1-19-2011.
- 4,015,584. **STROKE ADVOCACY NETWORK AND DESIGN**. NATIONAL STROKE ASSOCIATION, (U.S. CLS. 100, 101 AND 102). SN 85-221,671. PUB. 6-7-2011. FILED 1-19-2011.
- 4,015,594 (*See Class 4 for this trademark*).
- 4,015,596 (*See Class 4 for this trademark*).
- 4,015,599. **FROM (STANDARD CHARACTER)**. BOOKIT.COM, INC., MULTIPLE CLASS, (INT. CLS. 35 AND 39), (U.S. CLS. 100, 101, 102 AND 105). SN 85-221,928. PUB. 6-7-2011. FILED 1-20-2011.
- 4,015,604. **BULDFAX REMODELING INDEX (STANDARD CHARACTER)**. BUILDERADIUS, INC., (U.S. CLS. 100, 101 AND 102). SN 85-222,039. PUB. 6-7-2011. FILED 1-20-2011.
- 4,015,615. **GREEN SAMARITAN (STANDARD CHARACTER)**. SETH R. COAN, (U.S. CLS. 100, 101 AND 102). SN 85-222,350. PUB. 6-7-2011. FILED 1-20-2011.
- 4,015,621 (*See Class 29 for this trademark*).
- 4,015,640. **I LOVE ROCK N ROLL (STANDARD CHARACTER)**. HOOK ENTERTAINMENT, (U.S. CLS. 100, 101 AND 102). SN 85-223,132. PUB. 6-7-2011. FILED 1-21-2011.
- 4,015,671. **MISCELLANEOUS DESIGN**. AMBROZIAK, MARYANNE, (U.S. CLS. 100, 101 AND 102). SN 85-225,020. PUB. 6-7-2011. FILED 1-24-2011.
- 4,015,674. **Q-CENTRIX (STANDARD CHARACTER)**. Q-CENTRIX, LLC, (U.S. CLS. 100, 101 AND 102). SN 85-225,212. PUB. 6-7-2011. FILED 1-25-2011.
- 4,015,675. **FIRM SOLUTIONS AND DESIGN**. FIRM SOLUTIONS, LLC, MULTIPLE CLASS, (INT. CLS. 35, 41 AND 42), (U.S. CLS. 100, 101, 102 AND 107). SN 85-225,226. PUB. 6-7-2011. FILED 1-25-2011.
- 4,015,679. **WORKING INTELLIGENTLY (STANDARD CHARACTER)**. THE INTELLIGENT OFFICE SYSTEM, LLC, MULTIPLE CLASS, (INT. CLS. 35 AND 36), (U.S. CLS. 100, 101 AND 102). SN 85-225,583. PUB. 6-7-2011. FILED 1-25-2011.
- 4,015,680. **YOUR WORK/LIFE. BALANCED. (STANDARD CHARACTER)**. THE INTELLIGENT OFFICE SYSTEM, LLC, MULTIPLE CLASS, (INT. CLS. 35 AND 36), (U.S. CLS. 100, 101 AND 102). SN 85-225,586. PUB. 6-7-2011. FILED 1-25-2011.
- 4,015,681. **ADVOCAL (STANDARD CHARACTER)**. ADVOCAL, (U.S. CLS. 100, 101 AND 102). SN 85-225,830. PUB. 6-7-2011. FILED 1-25-2011.
- 4,015,694. **REAL FOUNDATIONS AND DESIGN**. REAL FOUNDATION, INC., MULTIPLE CLASS, (INT. CLS. 35 AND 36), (U.S. CLS. 100, 101 AND 102). SN 85-226,575. PUB. 6-7-2011. FILED 1-26-2011.
- 4,015,695. **REALFOUNDATIONS (STANDARD CHARACTER)**. REAL FOUNDATION, INC., MULTIPLE CLASS, (INT. CLS. 35 AND 36), (U.S. CLS. 100, 101 AND 102). SN 85-226,596. PUB. 6-7-2011. FILED 1-26-2011.
- 4,015,697. **RIIM (STANDARD CHARACTER)**. REAL FOUNDATION, INC., (U.S. CLS. 100, 101 AND 102). SN 85-226,661. PUB. 6-7-2011. FILED 1-26-2011.
- 4,015,700. **REALDISCOVERY (STANDARD CHARACTER)**. REAL FOUNDATION, INC., (U.S. CLS. 100, 101 AND 102). SN 85-226,766. PUB. 6-7-2011. FILED 1-26-2011.
- 4,015,705. **SMART HVAC PRODUCTS (STANDARD CHARACTER)**. SMART MEDIA, LLC, (U.S. CLS. 100, 101 AND 102). SN 85-226,980. PUB. 6-7-2011. FILED 1-26-2011.
- 4,015,713. **URBAN CARD (STANDARD CHARACTER)**. URBAN ENTERPRISES, LLC, (U.S. CLS. 100, 101 AND 102). SN 85-227,214. PUB. 6-7-2011. FILED 1-26-2011.
- 4,015,714. **BGCG (STANDARD CHARACTER)**. BRACKEN GARSON CONSULTING GROUP, LLC, (U.S. CLS. 100, 101 AND 102). SN 85-227,264. PUB. 6-7-2011. FILED 1-26-2011.
- 4,015,719. **ALL THINGS ADMIN (STANDARD CHARACTER)**. JULIE PERRINE INTERNATIONAL, LLC, DBA ALL THINGS ADMIN, (U.S. CLS. 100, 101 AND 102). SN 85-227,631. PUB. 6-7-2011. FILED 1-27-2011.
- 4,015,725. **IF YOU DON'T GIVE BACK NO ONE WILL LIKE YOU (STANDARD CHARACTER)**. CROWDRISE, LLC, (U.S. CLS. 100, 101 AND 102). SN 85-227,891. PUB. 6-7-2011. FILED 1-27-2011.
- 4,015,727. **MYMONEYMONITOR (STANDARD CHARACTER)**. NEW CONCEPTS DEVELOPMENT, INC., (U.S. CLS. 100, 101 AND 102). SN 85-227,943. PUB. 6-7-2011. FILED 1-27-2011.
- 4,015,731 (*See Class 9 for this trademark*).
- 4,015,734. **FREEPRICEALERTS (STANDARD CHARACTER)**. MYVBO, (U.S. CLS. 100, 101 AND 102). SN 85-228,459. PUB. 6-7-2011. FILED 1-28-2011.
- 4,015,747. **AUDIENCESCIENCE (STANDARD CHARACTER)**. AUDIENCESCIENCE INC., MULTIPLE CLASS, (INT. CLS. 35, 38, 39 AND 42), (U.S. CLS. 100, 101, 102, 104 AND 105). SN 85-228,609. PUB. 6-7-2011. FILED 1-28-2011.
- 4,015,748. **EZ STREET AND DESIGN**. EZ STREET, LLC, MULTIPLE CLASS, (INT. CLS. 35 AND 37), (U.S. CLS. 100, 101, 102, 103 AND 106). SN 85-228,650. PUB. 6-7-2011. FILED 1-28-2011.
- 4,015,762. **FITNESSBLOWOUT.COM (STANDARD CHARACTER)**. FITNESS CLUB WAREHOUSE INC., (U.S. CLS. 100, 101 AND 102). SN 85-228,798. PUB. 6-7-2011. FILED 1-28-2011.
- 4,015,769. **QLIVE (STANDARD CHARACTER)**. QUIBIDS LLC, (U.S. CLS. 100, 101 AND 102). SN 85-228,890. PUB. 6-7-2011. FILED 1-28-2011.
- 4,015,770. **METAL RABBIT MEDIA (STANDARD CHARACTER)**. METAL RABBIT MEDIA LLC, (U.S. CLS. 100, 101 AND 102). SN 85-228,921. PUB. 6-7-2011. FILED 1-28-2011.
- 4,015,777. **PROBOOKS (STANDARD CHARACTER)**. PROBOOKS, LLC, (U.S. CLS. 100, 101 AND 102). SN 85-229,006. PUB. 6-7-2011. FILED 1-28-2011.
- 4,015,809. **RRLX (STANDARD CHARACTER)**. RAIL LOGISTICS, LC, MULTIPLE CLASS, (INT. CLS. 35 AND 39), (U.S.

- CLS. 100, 101, 102 AND 105). SN 85-229,440. PUB. 6-7-2011. FILED 1-29-2011.
- 4,015,824. **PETEY'S TACKLE (STANDARD CHARACTER)**. PETEY'S TACKLE, LLC, (U.S. CLS. 100, 101 AND 102). SN 85-229,619. PUB. 6-7-2011. FILED 1-30-2011.
- 4,015,839. **TRUFFLINA (STYLIZED)**. TRUFFLINA, LLC, (U.S. CLS. 100, 101 AND 102). SN 85-229,877. PUB. 6-7-2011. FILED 1-31-2011.
- 4,015,848. **EQ (STYLIZED)**. S.D. WARREN COMPANY, DBA SAPPY FINE PAPER NORTH AMERICA, MULTIPLE CLASS, (INT. CLS. 35, 41 AND 42), (U.S. CLS. 100, 101, 102 AND 107). SN 85-230,001. PUB. 6-7-2011. FILED 1-31-2011.
- 4,015,860. **RELATIONSHIP CALLING (STANDARD CHARACTER)**. GEHEGAN & ASSOCIATES, (U.S. CLS. 100, 101 AND 102). SN 85-230,237. PUB. 6-7-2011. FILED 1-31-2011.
- 4,015,864. **GREAT LAKES SPORTS (STANDARD CHARACTER)**. TOLEDO PHYSICAL EDUCATION SUPPLY, INC., (U.S. CLS. 100, 101 AND 102). SN 85-230,314. PUB. 6-7-2011. FILED 1-31-2011.
- 4,015,880. **SLEEP FOR AMERICA (STANDARD CHARACTER)**. DIAMOND, NICOLE, AND DIAMOND, AARON, (U.S. CLS. 100, 101 AND 102). SN 85-230,559. PUB. 6-7-2011. FILED 1-31-2011.
- 4,015,882 (*See Class 16 for this trademark*).
- 4,015,883. **BIZNOLOGY (STANDARD CHARACTER)**. MIKE MORAN GROUP, LLC, (U.S. CLS. 100, 101 AND 102). SN 85-230,607. PUB. 6-7-2011. FILED 1-31-2011.
- 4,015,889. **CONCUSSION (STANDARD CHARACTER)**. CONCUSSION, LLP, (U.S. CLS. 100, 101 AND 102). SN 85-230,642. PUB. 6-7-2011. FILED 1-31-2011.
- 4,015,900. **VSPI (STANDARD CHARACTER)**. DAWN-BREAKER, INC., (U.S. CLS. 100, 101 AND 102). SN 85-230,866. PUB. 6-7-2011. FILED 2-1-2011.
- 4,015,907. **EXPONENTIAL INFLUENCE (STANDARD CHARACTER)**. EXPONENTIAL EDGE, INC., (U.S. CLS. 100, 101 AND 102). SN 85-230,977. PUB. 6-7-2011. FILED 2-1-2011.
- 4,015,908. **SL360.COM (STANDARD CHARACTER)**. USADATA, INC., (U.S. CLS. 100, 101 AND 102). SN 85-230,982. PUB. 6-7-2011. FILED 2-1-2011.
- 4,015,910. **SALESLEADS360.COM (STANDARD CHARACTER)**. USADATA, INC., (U.S. CLS. 100, 101 AND 102). SN 85-230,993. PUB. 6-7-2011. FILED 2-1-2011.
- 4,015,917. **LOQUEPIDA.COM (STANDARD CHARACTER)**. GLOBAL BUSINESS INTEGRATOR, INC., (U.S. CLS. 100, 101 AND 102). SN 85-231,050. PUB. 6-7-2011. FILED 2-1-2011.
- 4,015,920 (*See Class 25 for this trademark*).
- 4,015,925. **AN ESCAPE FROM THE EVERYDAY (STANDARD CHARACTER)**. LAS VEGAS CONVENTION AND VISITORS AUTHORITY, (U.S. CLS. 100, 101 AND 102). SN 85-231,178. PUB. 6-7-2011. FILED 2-1-2011.
- 4,015,927. **OCHYDRO (STANDARD CHARACTER)**. HAVRAN, LEIGHANN, AND HAVRAN, MARC, (U.S. CLS. 100, 101 AND 102). SN 85-231,193. PUB. 6-7-2011. FILED 2-1-2011.
- 4,015,948. **TRY ME FIRST...TRY ME LAST...JUST TRY ME!! (STANDARD CHARACTER)**. MCCRACKIN MOTORSPORTS, LLC, (U.S. CLS. 100, 101 AND 102). SN 85-231,622. PUB. 6-7-2011. FILED 2-1-2011.
- 4,015,956. **LURENIA (STANDARD CHARACTER)**. FAN, ASHLEY, (U.S. CLS. 100, 101 AND 102). SN 85-231,711. PUB. 6-7-2011. FILED 2-1-2011.
- 4,015,961. **CRITTERCOUPONS SAVINGS FOR YOUR PET FAMILY. AND DESIGN**. REVELL, ALAN, (U.S. CLS. 100, 101 AND 102). SN 85-231,805. PUB. 6-7-2011. FILED 2-1-2011.
- 4,015,963. **WE CARE . ENVIRONMENT . FOOD SAFETY . HEALTH . COMMUNITY . ANIMAL CARE AND DESIGN**. NATIONAL PORK PRODUCERS COUNCIL, (U.S. CLS. 100, 101 AND 102). SN 85-231,833. PUB. 6-7-2011. FILED 2-1-2011.
- 4,015,966. **LEADING REACH (STANDARD CHARACTER)**. SPARKSIGHT, INC., (U.S. CLS. 100, 101 AND 102). SN 85-231,898. PUB. 6-7-2011. FILED 2-1-2011.
- 4,015,967. **INTELLIGENT INFLUENCE I 2 AND DESIGN**. CALDWELL, DALE G., (U.S. CLS. 100, 101 AND 102). SN 85-231,936. PUB. 6-7-2011. FILED 2-2-2011.
- 4,015,979. **YOUR DREAM IS OUR BUSINESS (STANDARD CHARACTER)**. HEY NOW! ENTERTAINMENT L.L.C., (U.S. CLS. 100, 101 AND 102). SN 85-232,218. PUB. 6-7-2011. FILED 2-2-2011.
- 4,015,990. **LMI AND DESIGN**. LINK MARKETING, INC., (U.S. CLS. 100, 101 AND 102). SN 85-232,416. PUB. 6-7-2011. FILED 2-2-2011.
- 4,016,005. **YAMHILL VALLEY; OREGON'S STOMPING GROUND (STANDARD CHARACTER)**. YAMHILL VALLEY VISITORS ASSOCIATION, (U.S. CLS. 100, 101 AND 102). SN 85-232,658. PUB. 6-7-2011. FILED 2-2-2011.
- 4,016,015. **NOT YOUR FATHER'S OFFICE (STANDARD CHARACTER)**. COSTELLO, ANNA, (U.S. CLS. 100, 101 AND 102). SN 85-232,748. PUB. 6-7-2011. FILED 2-2-2011.
- 4,016,034. **STYLE FOR STUDENTS (STANDARD CHARACTER)**. ANNCO, INC., (U.S. CLS. 100, 101 AND 102). SN 85-233,262. PUB. 6-7-2011. FILED 2-3-2011.
- 4,016,052. **GROUPSTERS (STANDARD CHARACTER)**. GIS-COUNTS INC, (U.S. CLS. 100, 101 AND 102). SN 85-233,870. PUB. 6-7-2011. FILED 2-3-2011.
- 4,016,059. **UD (STANDARD CHARACTER)**. URBAN DECAY COSMETICS LLC, (U.S. CLS. 100, 101 AND 102). SN 85-234,673. PUB. 6-7-2011. FILED 2-4-2011.
- 4,016,061. **AEROBUY (STANDARD CHARACTER)**. AERO-EXCHANGE LTD., (U.S. CLS. 100, 101 AND 102). SN 85-234,496. PUB. 6-7-2011. FILED 2-8-2011.
- 4,016,087 (*See Class 9 for this trademark*).
- 4,016,107. **TEAMDNA (STANDARD CHARACTER)**. SUCCESSDNA LLC, (U.S. CLS. 100, 101 AND 102). SN 85-259,123. PUB. 6-7-2011. FILED 3-6-2011.
- 4,016,111. **WHEN REPUTATION MATTERS (STANDARD CHARACTER)**. ZELO PUBLIC RELATIONS, LLC, (U.S. CLS. 100, 101 AND 102). SN 85-260,270. PUB. 6-7-2011. FILED 3-7-2011.
- 4,016,112. **SPECIALIZED (STANDARD CHARACTER)**. SPECIALIZED BICYCLE COMPONENTS, INC., MULTIPLE CLASS, (INT. CLS. 35 AND 36), (U.S. CLS. 100, 101 AND 102). SN 85-260,993. PUB. 6-7-2011. FILED 3-8-2011.
- 4,016,113. **LHK (STANDARD CHARACTER)**. LHK PARTNERS, INC., (U.S. CLS. 100, 101 AND 102). SN 85-261,179. PUB. 6-7-2011. FILED 3-8-2011.
- 4,016,114. **LHK PARTNERS INC. AND DESIGN**. LHK PARTNERS, INC., (U.S. CLS. 100, 101 AND 102). SN 85-261,208. PUB. 6-7-2011. FILED 3-8-2011.
- 4,016,129. **TXT OUR WEDDING (STANDARD CHARACTER)**. TXT MY REGISTRY, LLC, DBA TXT MY REGISTRY, (U.S. CLS. 100, 101 AND 102). SN 85-281,148. PUB. 6-7-2011. FILED 3-30-2011.
- 4,016,132. **TXT OUR REGISTRY (STANDARD CHARACTER)**. TXT MY REGISTRY, LLC, DBA TXT OUR REGISTRY, (U.S. CLS. 100, 101 AND 102). SN 85-285,957. PUB. 6-7-2011. FILED 4-4-2011.
- 4,016,135. **LIFE IS SHORT. SUMMER IS SHORTER. (STANDARD CHARACTER)**. LAS VEGAS CONVENTION AND VISITORS AUTHORITY, (U.S. CLS. 100, 101 AND 102). SN 85-288,851. PUB. 6-7-2011. FILED 4-7-2011.
- 4,016,137. **NEEBO AND DESIGN**. NEBRASKA BOOK COMPANY, INC., (U.S. CLS. 100, 101 AND 102). SN 85-290,374. PUB. 6-7-2011. FILED 4-8-2011.

CLASS 36—INSURANCE AND FINANCIAL

- 4,014,204. **ULUPONO INITIATIVE (STANDARD CHARACTER)**. ULUPONO INITIATIVE LLC, (U.S. CLS. 100, 101 AND 102). SN 76-699,451. PUB. 6-7-2011. FILED 9-14-2009.
- 4,014,205. **PRIMELENDING A PLANS CAPITAL COMPANY AND DESIGN**. PLAINSCAPITAL CORPORATION, (U.S. CLS. 100, 101 AND 102). SN 76-700,623. PUB. 6-7-2011. FILED 12-2-2009.
- 4,014,221 (*See Class 35 for this trademark*).
- 4,014,227. **THE MIAMI FOUNDATION FOR A GREATER MIAMI AND DESIGN**. MIAMI FOUNDATION, INC., THE, (U.S. CLS. 100, 101 AND 102). SN 76-706,036. PUB. 6-7-2011. FILED 1-18-2011.
- 4,014,258. **ORBISDIRECT (STANDARD CHARACTER)**. ORBIS HOLDINGS LIMITED, (U.S. CLS. 100, 101 AND 102). SN 77-426,806. PUB. 6-7-2011. FILED 3-19-2008.
- 4,014,259. **ORBIS-DIRECT (STANDARD CHARACTER)**. ORBIS HOLDINGS LIMITED, (U.S. CLS. 100, 101 AND 102).

- SN 77-426,820. PUB. 6-7-2011. FILED 3-19-2008.
- 4,014,285. **UTI UTI MUTUAL FUND AND DESIGN. UTI ASSET MANAGEMENT COMPANY LIMITED**, (U.S. CLS. 100, 101 AND 102). SN 77-650,382. PUB. 6-7-2011. FILED 1-15-2009.
- 4,014,298 (*See Class 35 for this trademark*).
- 4,014,310 (*See Class 35 for this trademark*).
- 4,014,321 (*See Class 35 for this trademark*).
- 4,014,361. **PERSONALMANAGER (STANDARD CHARACTER)**. BANK OF AMERICA CORPORATION, (U.S. CLS. 100, 101 AND 102). SN 77-886,282. PUB. 6-7-2011. FILED 12-4-2009.
- 4,014,382 (*See Class 9 for this trademark*).
- 4,014,400 (*See Class 35 for this trademark*).
- 4,014,407. **STARPOWER STAR AND DESIGN. DISTRESSED PROPERTY INSTITUTE, LLC**, (U.S. CLS. 100, 101 AND 102). SN 77-944,705. PUB. 1-4-2011. FILED 2-25-2010.
- 4,014,413. **NOW YOU'RE SURE (STANDARD CHARACTER)**. MCKELLAR STRUCTURED SETTLEMENTS INC., MULTIPLE CLASS, (INT. CLS. 36 AND 45), (U.S. CLS. 100, 101 AND 102). SN 77-951,823. PUB. 6-7-2011. FILED 3-5-2010.
- 4,014,414. **BILLIONS OF DOLLARS INVESTED, NOT A PENNY LOST. (STANDARD CHARACTER)**. MCKELLAR STRUCTURED SETTLEMENTS INC., MULTIPLE CLASS, (INT. CLS. 36 AND 45), (U.S. CLS. 100, 101 AND 102). SN 77-951,833. PUB. 6-7-2011. FILED 3-5-2010.
- 4,014,417. **HEROES HELPING HEROES (STANDARD CHARACTER)**. VETERANS OF VALOR, INC., MULTIPLE CLASS, (INT. CLS. 36 AND 45), (U.S. CLS. 100, 101 AND 102). SN 77-953,473. PUB. 3-1-2011. FILED 3-8-2010.
- 4,014,418. **HEROES HELPING HEROES VV VETERANS OF VALOR AND DESIGN. VETERANS OF VALOR, INC.**, MULTIPLE CLASS, (INT. CLS. 36 AND 45), (U.S. CLS. 100, 101 AND 102). SN 77-953,481. PUB. 3-1-2011. FILED 3-8-2010.
- 4,014,422. **RIVERHEAD BLUES & MUSIC FESTIVAL (STANDARD CHARACTER)**. COUNCIL FOR THE VAIL-LEAVITT MUSIC HALL, INC., (U.S. CLS. 100, 101 AND 102). SN 77-963,525. PUB. 6-7-2011. FILED 3-19-2010.
- 4,014,475 (*See Class 16 for this trademark*).
- 4,014,492 (*See Class 29 for this trademark*).
- 4,014,506 (*See Class 1 for this trademark*).
- 4,014,536. **WEALTHMI (STANDARD CHARACTER)**. MICRO-LIFE INTELLECTUAL PROPERTY GMBH, MULTIPLE CLASS, (INT. CLS. 36 AND 41), (U.S. CLS. 100, 101, 102 AND 107). SN 79-086,058. PUB. 6-7-2011. FILED 7-27-2010.
- 4,014,560 (*See Class 35 for this trademark*).
- 4,014,561 (*See Class 35 for this trademark*).
- 4,014,570 (*See Class 35 for this trademark*).
- 4,014,571 (*See Class 35 for this trademark*).
- 4,014,710 (*See Class 9 for this trademark*).
- 4,014,711 (*See Class 9 for this trademark*).
- 4,014,740 (*See Class 9 for this trademark*).
- 4,014,746. **EPIPHANY (STANDARD CHARACTER)**. RETIREMENT BENEFIT SOLUTIONS, LLC, (U.S. CLS. 100, 101 AND 102). SN 85-056,435. PUB. 6-7-2011. FILED 6-7-2010.
- 4,014,824. **POLICYDOG (STANDARD CHARACTER)**. POLICY DOG, LLC, (U.S. CLS. 100, 101 AND 102). SN 85-075,949. PUB. 6-7-2011. FILED 7-1-2010.
- 4,014,845. **HOOP HEROES (STANDARD CHARACTER)**. AFTER-SCHOOL ALL-STARS, (U.S. CLS. 100, 101 AND 102). SN 85-079,759. PUB. 6-7-2011. FILED 7-7-2010.
- 4,014,890. **PENTUCKET BANK PENTUCKET BANK "THE LITTLE BANK THAT COULD" AND DESIGN. PENTUCKET BANK**, (U.S. CLS. 100, 101 AND 102). SN 85-090,237. PUB. 6-7-2011. FILED 7-22-2010.
- 4,014,910 (*See Class 35 for this trademark*).
- 4,014,922 (*See Class 16 for this trademark*).
- 4,014,923. **BILLCONNECT (STANDARD CHARACTER)**. EDI HEALTH GROUP, INC., DBA DENTALXCHANGE, (U.S. CLS. 100, 101 AND 102). SN 85-095,278. PUB. 6-7-2011. FILED 7-28-2010.
- 4,014,930. **TEACHERS INSURANCE AND ANNUITY ASSOCIATION OF AMERICA (STANDARD CHARACTER)**. TEACHERS INSURANCE AND ANNUITY ASSOCIATION OF AMERICA, (U.S. CLS. 100, 101 AND 102). SN 85-096,402. PUB. 6-7-2011. FILED 7-29-2010.
- 4,014,942. **BOB (STANDARD CHARACTER)**. BELVOIR FEDERAL CREDIT UNION, (U.S. CLS. 100, 101 AND 102). SN 85-100,699. PUB. 6-7-2011. FILED 8-5-2010.
- 4,014,962. **WBN WORLDWIDE BROKER NETWORK AND DESIGN. WBN LIMITED**, (U.S. CLS. 100, 101 AND 102). SN 85-105,014. PUB. 6-7-2011. FILED 8-11-2010.
- 4,014,964. **GLOBAL LEISURE PARTNERS (STANDARD CHARACTER)**. GLOBAL LEISURE PARTNERS LLP, (U.S. CLS. 100, 101 AND 102). SN 85-105,322. PUB. 6-7-2011. FILED 8-11-2010.
- 4,014,968. **A FEAST OF THE HEART AND DESIGN. PATRICIA JIMENEZ, DBA THE RAUL JIMENEZ ANNUAL THANKSGIVING DINNER FUND, INC.**, (U.S. CLS. 100, 101 AND 102). SN 85-106,415. PUB. 6-7-2011. FILED 8-12-2010.
- 4,014,977 (*See Class 35 for this trademark*).
- 4,015,008. **4G (STANDARD CHARACTER)**. SCHOLARSHIP AMERICA, INC., MULTIPLE CLASS, (INT. CLS. 36 AND 41), (U.S. CLS. 100, 101, 102 AND 107). SN 85-121,440. PUB. 6-7-2011. FILED 9-2-2010.
- 4,015,043. **FIRST VICTORIA (STANDARD CHARACTER)**. FIRST VICTORIA NATIONAL BANK, (U.S. CLS. 100, 101 AND 102). SN 85-130,099. PUB. 6-7-2011. FILED 9-15-2010.
- 4,015,079 (*See Class 35 for this trademark*).
- 4,015,111 (*See Class 35 for this trademark*).
- 4,015,129. **MISCELLANEOUS DESIGN. NATIONAL FIREFIGHTER SKI RACES**, (U.S. CLS. 100, 101 AND 102). SN 85-156,885. PUB. 6-7-2011. FILED 10-20-2010.
- 4,015,134. **CITIZENS ALLIANCE BANK CUSTOMER DRIVEN. COMMUNITY FOCUSED. (STYLIZED)**. CITIZENS ALLIANCE BANK, (U.S. CLS. 100, 101 AND 102). SN 85-158,059. PUB. 6-7-2011. FILED 10-21-2010.
- 4,015,159. **GREAT RANGE CAPITAL (STANDARD CHARACTER)**. GREAT RANGE CAPITAL, LLC, (U.S. CLS. 100, 101 AND 102). SN 85-167,213. PUB. 6-7-2011. FILED 11-2-2010.
- 4,015,176. **BANKERS ADVOCATE INVESTMENT BANKERS FOR THE ENTREPRENEUR ... AND DESIGN. BANKERS ADVOCATE GROUP LLC**, (U.S. CLS. 100, 101 AND 102). SN 85-171,079. PUB. 6-7-2011. FILED 11-8-2010.
- 4,015,179 (*See Class 35 for this trademark*).
- 4,015,180 (*See Class 35 for this trademark*).
- 4,015,205. **THE LONG TERM CARE LADY (STANDARD CHARACTER)**. THE LONG TERM CARE LADY, LLC, (U.S. CLS. 100, 101 AND 102). SN 85-178,505. PUB. 6-7-2011. FILED 11-16-2010.
- 4,015,207. **NIFASTRACK (STANDARD CHARACTER)**. NIF GROUP, INC., (U.S. CLS. 100, 101 AND 102). SN 85-179,239. PUB. 6-7-2011. FILED 11-17-2010.
- 4,015,213 (*See Class 35 for this trademark*).
- 4,015,224 (*See Class 35 for this trademark*).
- 4,015,239. **CENTRUE BANK AND DESIGN. CENTRUE BANK**, (U.S. CLS. 100, 101 AND 102). SN 85-188,245. PUB. 6-7-2011. FILED 12-1-2010.
- 4,015,245. **MISCELLANEOUS DESIGN. NORTH BROWARD HOSPITAL DISTRICT**, (U.S. CLS. 100, 101 AND 102). SN 85-189,143. PUB. 6-7-2011. FILED 12-2-2010.
- 4,015,248. **ALLY BANK (STYLIZED)**. ALLY FINANCIAL INC., (U.S. CLS. 100, 101 AND 102). SN 85-191,446. PUB. 6-7-2011. FILED 12-6-2010.
- 4,015,260 (*See Class 35 for this trademark*).
- 4,015,279. **BE A LIFELINE. (STANDARD CHARACTER)**. THE BONE MARROW FOUNDATION, (U.S. CLS. 100, 101 AND 102). SN 85-197,089. PUB. 6-7-2011. FILED 12-14-2010.
- 4,015,307. **CEICU CHICAGOLAND ELECTRICAL INDUSTRY CREDIT UNION AND DESIGN. CHICAGOLAND ELECTRICAL INDUSTRY CREDIT UNION, AKA CEICU**, (U.S. CLS. 100, 101 AND 102). SN 85-201,610. PUB. 6-7-2011. FILED 12-20-2010.
- 4,015,324. **NEUBERGER BERMAN SELECT EQUITIES FUND (STANDARD CHARACTER)**. NEUBERGER BERMAN MANAGEMENT LLC, (U.S. CLS. 100, 101 AND 102). SN 85-203,375. PUB. 6-7-2011. FILED 12-21-2010.
- 4,015,325. **NEUBERGER BERMAN SMALL CAP GROWTH FUND (STANDARD CHARACTER)**. NEUBERGER BERMAN MANAGEMENT LLC, (U.S. CLS. 100, 101 AND 102). SN 85-203,378. PUB. 6-7-2011. FILED 12-21-2010.
- 4,015,326. **NEUBERGER BERMAN INTERNATIONAL LARGE CAP FUND (STANDARD CHARACTER)**. NEUBERGER BERMAN MANAGEMENT LLC, (U.S. CLS. 100, 101 AND

- 102). SN 85-203,385. PUB. 6-7-2011. FILED 12-21-2010.
- 4,015,331. **EAST COAST (STANDARD CHARACTER)**. ODESS, DANIEL B., (U.S. CLS. 100, 101 AND 102). SN 85-204,280. PUB. 6-7-2011. FILED 12-22-2010.
- 4,015,339. **PARALLAX OFFSHORE INVESTORS FUND, LTD. (STANDARD CHARACTER)**. JESAGA, LLC, (U.S. CLS. 100, 101 AND 102). SN 85-206,068. PUB. 6-7-2011. FILED 12-27-2010.
- 4,015,387. **FLORIDA LACROSSE CLASSIC AND DESIGN**. FLORIDA YOUTH LACROSSE FOUNDATION, INC., (U.S. CLS. 100, 101 AND 102). SN 85-211,773. PUB. 6-7-2011. FILED 1-6-2011.
- 4,015,390 (*See Class 35 for this trademark*).
- 4,015,394. **LETTERS OF HAPPINESS (STANDARD CHARACTER)**. SMULSON, ANDREW NEAL, AND LOUDERMILK, BRENDAN COOPER, AND GIANCOLA, NICHOLAS JOHN, (U.S. CLS. 100, 101 AND 102). SN 85-212,583. PUB. 6-7-2011. FILED 1-7-2011.
- 4,015,435. **360 INVESTMENTS AND DESIGN**. 360 INVESTMENTS, INC., (U.S. CLS. 100, 101 AND 102). SN 85-216,011. PUB. 6-7-2011. FILED 1-12-2011.
- 4,015,476. **DANCERS CARE FOUNDATION (STANDARD CHARACTER)**. DANCERS CARE FOUNDATION, INC., (U.S. CLS. 100, 101 AND 102). SN 85-218,361. PUB. 6-7-2011. FILED 1-14-2011.
- 4,015,484. **DRIVE TO SURVIVE (STANDARD CHARACTER)**. RIZZI, RON, DBA CARS AND COFFEE, INC., (U.S. CLS. 100, 101 AND 102). SN 85-218,707. PUB. 6-7-2011. FILED 1-15-2011.
- 4,015,509 (*See Class 35 for this trademark*).
- 4,015,535 (*See Class 35 for this trademark*).
- 4,015,538. **BANCOPPEL (STANDARD CHARACTER)**. COPPEL, S.A. DE C.V., (U.S. CLS. 100, 101 AND 102). SN 85-220,644. PUB. 6-7-2011. FILED 1-19-2011.
- 4,015,545. **YOUR LIFE. YOUR WEALTH. YOUR PLAN. (STANDARD CHARACTER)**. EVAN ARMIN WALTER, AND PATRICIA GABERINO CAREY, AND BRIAN DOUGLAS MITCHELL, (U.S. CLS. 100, 101 AND 102). SN 85-220,784. PUB. 6-7-2011. FILED 1-19-2011.
- 4,015,556. **MISCELLANEOUS DESIGN**. METABANK, (U.S. CLS. 100, 101 AND 102). SN 85-221,025. PUB. 6-7-2011. FILED 1-19-2011.
- 4,015,565. **HARRY WINSTON HOPE FOUNDATION (STANDARD CHARACTER)**. HARRY WINSTON HOPE FOUNDATION, INC., A WHOLLY-OWNED SUBSIDIARY OF HARRY WINSTON, INC., (U.S. CLS. 100, 101 AND 102). SN 85-221,245. PUB. 6-7-2011. FILED 1-19-2011.
- 4,015,567. **WATER WITHOUT BORDERS (STANDARD CHARACTER)**. WATER WITHOUT BORDERS, CORP., (U.S. CLS. 100, 101 AND 102). SN 85-221,266. PUB. 6-7-2011. FILED 1-19-2011.
- 4,015,569. **RLIPACK (STANDARD CHARACTER)**. RLI INSURANCE COMPANY, (U.S. CLS. 100, 101 AND 102). SN 85-221,290. PUB. 6-7-2011. FILED 1-19-2011.
- 4,015,570. **RLICOMP (STANDARD CHARACTER)**. RLI INSURANCE COMPANY, (U.S. CLS. 100, 101 AND 102). SN 85-221,304. PUB. 6-7-2011. FILED 1-19-2011.
- 4,015,574. **CUTTING EDGE (STANDARD CHARACTER)**. GE MONEY BANK, (U.S. CLS. 100, 101 AND 102). SN 85-221,396. PUB. 6-7-2011. FILED 1-19-2011.
- 4,015,581. **CEDARS-SINAI (STANDARD CHARACTER)**. CEDARS-SINAI MEDICAL CENTER, MULTIPLE CLASS, (INT. CLS. 36, 41 AND 42), (U.S. CLS. 100, 101, 102 AND 107). SN 85-221,563. PUB. 6-7-2011. FILED 1-19-2011.
- 4,015,582. **C S AND DESIGN**. CEDARS-SINAI MEDICAL CENTER, MULTIPLE CLASS, (INT. CLS. 36, 41 AND 42), (U.S. CLS. 100, 101, 102 AND 107). SN 85-221,575. PUB. 6-7-2011. FILED 1-19-2011.
- 4,015,605. **SPDR AND DESIGN**. STANDARD & POOR'S FINANCIAL SERVICES LLC, (U.S. CLS. 100, 101 AND 102). SN 85-222,069. PUB. 6-7-2011. FILED 1-20-2011.
- 4,015,613. **MEMBERSPLUS (STANDARD CHARACTER)**. MEMBERS COOPERATIVE CREDIT UNION, (U.S. CLS. 100, 101 AND 102). SN 85-222,332. PUB. 6-7-2011. FILED 1-20-2011.
- 4,015,624. **KASINA FOUNDATION (STANDARD CHARACTER)**. KASINA, LLC, (U.S. CLS. 100, 101 AND 102). SN 85-222,498. PUB. 6-7-2011. FILED 1-20-2011.
- 4,015,660. **SHIP WITH THE CARRIER. INSURE WITH PARCEL INSURANCE PLAN. (STANDARD CHARACTER)**. BROWN & BROWN OF MISSOURI, INC., (U.S. CLS. 100, 101 AND 102). SN 85-224,740. PUB. 6-7-2011. FILED 1-24-2011.
- 4,015,679 (*See Class 35 for this trademark*).
- 4,015,680 (*See Class 35 for this trademark*).
- 4,015,694 (*See Class 35 for this trademark*).
- 4,015,695 (*See Class 35 for this trademark*).
- 4,015,772. **FIRSTNET (STANDARD CHARACTER)**. FIRST CITIZENS BANK, (U.S. CLS. 100, 101 AND 102). SN 85-228,935. PUB. 6-7-2011. FILED 1-28-2011.
- 4,015,786. **WHY BUILD A BRAND WHEN YOU CAN BUY ONE? (STANDARD CHARACTER)**. PROFORMA INC., (U.S. CLS. 100, 101 AND 102). SN 85-229,081. PUB. 6-7-2011. FILED 1-28-2011.
- 4,015,788. **PURPLE HEART (STANDARD CHARACTER)**. MILITARY ORDER OF THE PURPLE HEART SERVICE FOUNDATION, INC., (U.S. CLS. 100, 101 AND 102). SN 85-229,127. PUB. 6-7-2011. FILED 1-28-2011.
- 4,015,791. **CITY OF JOY (STANDARD CHARACTER)**. V-DAY CORPORATION, (U.S. CLS. 100, 101 AND 102). SN 85-229,143. PUB. 6-7-2011. FILED 1-28-2011.
- 4,015,833. **L & M SOLUTIONS (STANDARD CHARACTER)**. L & M SOLUTIONS, INC., (U.S. CLS. 100, 101 AND 102). SN 85-229,844. PUB. 6-7-2011. FILED 1-31-2011.
- 4,015,841. **WINTERGREEN (STANDARD CHARACTER)**. WINTERGREEN ADVISERS, LLC, (U.S. CLS. 100, 101 AND 102). SN 85-229,887. PUB. 6-7-2011. FILED 1-31-2011.
- 4,015,850. **PLEDGE THE MILES YOU DRIVE (STANDARD CHARACTER)**. RON RIZZI, DBA CARS AND COFFEE, INC., (U.S. CLS. 100, 101 AND 102). SN 85-230,032. PUB. 6-7-2011. FILED 1-31-2011.
- 4,015,851. **PLEDGE THE MILES YOU RIDE (STANDARD CHARACTER)**. RON RIZZI, DBA CARS AND COFFEE, INC., (U.S. CLS. 100, 101 AND 102). SN 85-230,057. PUB. 6-7-2011. FILED 1-31-2011.
- 4,015,862. **GRANVILLE (STANDARD CHARACTER)**. GRANVILLE HOMES, INC., MULTIPLE CLASS, (INT. CLS. 36 AND 37), (U.S. CLS. 100, 101, 102, 103 AND 106). SN 85-230,271. PUB. 6-7-2011. FILED 1-31-2011.
- 4,015,888. **GIVELOUD START SOMETHING. CHANGE EVERYTHING. AND DESIGN**. MARTIN, ADAM, (U.S. CLS. 100, 101 AND 102). SN 85-230,640. PUB. 6-7-2011. FILED 1-31-2011.
- 4,015,942. **WEWORK (STANDARD CHARACTER)**. WE HOLDINGS LLC, (U.S. CLS. 100, 101 AND 102). SN 85-231,506. PUB. 6-7-2011. FILED 2-1-2011.
- 4,015,968. **SLT (STYLIZED)**. SYDNEY LAUREN TABAKIN MEMORIAL FUND INC., (U.S. CLS. 100, 101 AND 102). SN 85-231,978. PUB. 6-7-2011. FILED 2-2-2011.
- 4,015,970. **SBFE (STANDARD CHARACTER)**. SMALL BUSINESS FINANCIAL EXCHANGE, INC., (U.S. CLS. 100, 101 AND 102). SN 85-231,984. PUB. 6-7-2011. FILED 2-2-2011.
- 4,016,001. **THE VICTORY SUMMIT (STANDARD CHARACTER)**. DAVIS PHINNEY FOUNDATION, MULTIPLE CLASS, (INT. CLS. 36 AND 41), (U.S. CLS. 100, 101, 102 AND 107). SN 85-232,553. PUB. 6-7-2011. FILED 2-2-2011.
- 4,016,003. **THE BEAUTY OF BELIZE (STANDARD CHARACTER)**. THE PLACENCIA GROUP, LTD., MULTIPLE CLASS, (INT. CLS. 36 AND 37), (U.S. CLS. 100, 101, 102, 103 AND 106). SN 85-232,595. PUB. 6-7-2011. FILED 2-2-2011.
- 4,016,037. **MYTRACK (STANDARD CHARACTER)**. TRACK DATA CORPORATION, (U.S. CLS. 100, 101 AND 102). SN 85-233,377. PUB. 6-7-2011. FILED 2-3-2011.
- 4,016,041. **FASTTRACK (STANDARD CHARACTER)**. TRACK DATA CORPORATION, (U.S. CLS. 100, 101 AND 102). SN 85-233,494. PUB. 6-7-2011. FILED 2-3-2011.
- 4,016,090. **LILLIBRIDGE AND DESIGN**. VENTAS, INC., MULTIPLE CLASS, (INT. CLS. 36 AND 37), (U.S. CLS. 100, 101, 102, 103 AND 106). SN 85-248,539. PUB. 6-7-2011. FILED 2-22-2011.
- 4,016,109. **ROAD TO LONDON (STANDARD CHARACTER)**. UNITED STATES OLYMPIC COMMITTEE, (U.S. CLS. 100, 101 AND 102). SN 85-259,676. PUB. 6-7-2011. FILED 3-7-2011.
- 4,016,112 (*See Class 35 for this trademark*).
- 4,016,115. **HELP A SISTER OUT (STANDARD CHARACTER)**. CANOPY MANAGEMENT, LLC, (U.S. CLS. 100, 101 AND

102). SN 85-263,085. PUB. 6-7-2011. FILED 3-10-2011.

CLASS 37—CONSTRUCTION AND REPAIR

- 4,014,219 (*See Class 35 for this trademark*).
 4,014,247 (*See Class 9 for this trademark*).
 4,014,264. **THINWARE (STANDARD CHARACTER)**. THINWARE, INC., MULTIPLE CLASS, (INT. CLS. 37 AND 42), (U.S. CLS. 100, 101, 103 AND 106). SN 77-547,733. PUB. 6-7-2011. FILED 8-14-2008.
 4,014,267 (*See Class 35 for this trademark*).
 4,014,289. **INFUSION DESIGN (STANDARD CHARACTER)**. PANARO CONSTRUCTION, INC., AND PANARO CONSTRUCTION, INC., (U.S. CLS. 100, 103 AND 106). SN 77-664,485. PUB. 6-7-2011. FILED 2-5-2009.
 4,014,292 (*See Class 1 for this trademark*).
 4,014,333 (*See Class 11 for this trademark*).
 4,014,345. **SAUTTER CRANE RENTAL (STANDARD CHARACTER)**. SAUTTER CRANE RENTAL, INC., MULTIPLE CLASS, (INT. CLS. 37 AND 39), (U.S. CLS. 100, 103, 105 AND 106). SN 77-849,765. PUB. 6-7-2011. FILED 10-15-2009.
 4,014,397. **MAHOGANY BUILDERS (STANDARD CHARACTER)**. LEDERER CONSTRUCTION, LLC, DBA MAHOGANY BUILDERS, MULTIPLE CLASS, (INT. CLS. 37 AND 42), (U.S. CLS. 100, 101, 103 AND 106). SN 77-922,101. PUB. 6-7-2011. FILED 1-28-2010.
 4,014,475 (*See Class 16 for this trademark*).
 4,014,485 (*See Class 6 for this trademark*).
 4,014,486 (*See Class 4 for this trademark*).
 4,014,493 (*See Class 7 for this trademark*).
 4,014,531 (*See Class 7 for this trademark*).
 4,014,532 (*See Class 7 for this trademark*).
 4,014,547 (*See Class 7 for this trademark*).
 4,014,557. **BUFFALO (STYLIZED)**. KABUSHIKI KAISHA MELCO HOLDINGS, TRADING AS MELCO HOLDINGS INC., (U.S. CLS. 100, 103 AND 106). SN 79-087,096. PUB. 6-7-2011. FILED 3-18-2010.
 4,014,570 (*See Class 35 for this trademark*).
 4,014,571 (*See Class 35 for this trademark*).
 4,014,615 (*See Class 19 for this trademark*).
 4,014,714. **BUSOZENE AND DESIGN**. APEE LTD, (U.S. CLS. 100, 103 AND 106). SN 85-043,233. PUB. 6-7-2011. FILED 5-19-2010.
 4,014,725. **BCI COMMUNICATIONS, INC UNITEK GLOBAL SERVICES COMPANY AND DESIGN**. BCI COMMUNICATIONS, INC., (U.S. CLS. 100, 103 AND 106). SN 85-050,298. PUB. 6-7-2011. FILED 5-28-2010.
 4,014,730. **INFORMATION TECHNOLOGY AND INVENTOR SERVICES LLC (STANDARD CHARACTER)**. INFORMATION TECHNOLOGY AND INVENTOR SERVICES LLC, (U.S. CLS. 100, 103 AND 106). SN 85-051,557. PUB. 6-7-2011. FILED 6-1-2010.
 4,014,758. **BASEMENT FLOOD PROTECTOR (STANDARD CHARACTER)**. BASEMENT FLOOD PROTECTOR, (U.S. CLS. 100, 103 AND 106). SN 85-061,790. PUB. 6-7-2011. FILED 6-14-2010.
 4,014,847. **RS LIGHTING SERVICES, INC. (STANDARD CHARACTER)**. RS LIGHTING SERVICES, INC., (U.S. CLS. 100, 103 AND 106). SN 85-080,426. PUB. 6-7-2011. FILED 7-8-2010.
 4,014,945. **ARMISTEAD MECHANICAL, INC. (STANDARD CHARACTER)**. ARMISTEAD MECHANICAL, INC., MULTIPLE CLASS, (INT. CLS. 37 AND 40), (U.S. CLS. 100, 103 AND 106). SN 85-101,040. PUB. 6-7-2011. FILED 8-5-2010.
 4,014,977 (*See Class 35 for this trademark*).
 4,014,987. **AMERICAN VISION WINDOWS (STANDARD CHARACTER)**. HERREN, WILLIAM, AND HERREN, KATHLEEN, (U.S. CLS. 100, 103 AND 106). SN 85-115,656. PUB. 6-7-2011. FILED 8-25-2010.
 4,014,990 (*See Class 21 for this trademark*).
 4,014,992. **A ARMISTEAD MECHANICAL, INC. AND DESIGN**. ARMISTEAD MECHANICAL, INC., MULTIPLE CLASS, (INT. CLS. 37 AND 40), (U.S. CLS. 100, 103 AND 106). SN 85-118,850. PUB. 6-7-2011. FILED 8-30-2010.
 4,015,063. **MT MUSEUM TOWER AND DESIGN**. MUSEUM TOWER, LP, (U.S. CLS. 100, 103 AND 106). SN 85-137,574. PUB. 6-7-2011. FILED 9-24-2010.
 4,015,082. **MISCELLANEOUS DESIGN**. AIR CHINA LIMITED, MULTIPLE CLASS, (INT. CLS. 37 AND 39), (U.S. CLS. 100, 103, 105 AND 106). SN 85-142,477. PUB. 6-7-2011. FILED 9-30-2010.
 4,015,086. **T TERRAPHASE ENGINEERING AND DESIGN**. TERRAPHASE ENGINEERING INC., MULTIPLE CLASS, (INT. CLS. 37, 40 AND 42), (U.S. CLS. 100, 101, 103 AND 106). SN 85-142,859. PUB. 6-7-2011. FILED 10-1-2010.
 4,015,108. **HEATER WELLNESS (STANDARD CHARACTER)**. VN CORP., MULTIPLE CLASS, (INT. CLS. 37 AND 42), (U.S. CLS. 100, 101, 103 AND 106). SN 85-149,858. PUB. 6-7-2011. FILED 10-11-2010.
 4,015,111 (*See Class 35 for this trademark*).
 4,015,120. **REDESIGN FOR LIFE (STANDARD CHARACTER)**. NOVELLIS, LLC, (U.S. CLS. 100, 103 AND 106). SN 85-154,465. PUB. 6-7-2011. FILED 10-17-2010.
 4,015,179 (*See Class 35 for this trademark*).
 4,015,180 (*See Class 35 for this trademark*).
 4,015,185 (*See Class 35 for this trademark*).
 4,015,193. **4-E CONSTRUCTION (STANDARD CHARACTER)**. EGAN, CHARLES H., DBA 4-E CONSTRUCTION, (U.S. CLS. 100, 103 AND 106). SN 85-176,159. PUB. 6-7-2011. FILED 11-13-2010.
 4,015,209. **PRO REPAIR AND DESIGN**. HS TM, LLC, (U.S. CLS. 100, 103 AND 106). SN 85-179,853. PUB. 6-7-2011. FILED 11-18-2010.
 4,015,213 (*See Class 35 for this trademark*).
 4,015,217. **WHERE PRIDE STILL MATTERS (STANDARD CHARACTER)**. SUPERIOR CONTRACT CLEANERS, INC., (U.S. CLS. 100, 103 AND 106). SN 85-183,216. PUB. 6-7-2011. FILED 11-23-2010.
 4,015,237. **KNOWWATER AND DESIGN**. HIGHGROVE PARTNERS, LLC, MULTIPLE CLASS, (INT. CLS. 37 AND 44), (U.S. CLS. 100, 101, 103 AND 106). SN 85-187,924. PUB. 6-7-2011. FILED 12-1-2010.
 4,015,238. **KNOWWATER (STANDARD CHARACTER)**. HIGHGROVE PARTNERS, LLC, MULTIPLE CLASS, (INT. CLS. 37 AND 44), (U.S. CLS. 100, 101, 103 AND 106). SN 85-187,933. PUB. 6-7-2011. FILED 12-1-2010.
 4,015,260 (*See Class 35 for this trademark*).
 4,015,292. **BED BUG 911 (STANDARD CHARACTER)**. BED BUG 911 CORP., (U.S. CLS. 100, 103 AND 106). SN 85-199,439. PUB. 6-7-2011. FILED 12-16-2010.
 4,015,334 (*See Class 35 for this trademark*).
 4,015,391 (*See Class 35 for this trademark*).
 4,015,444. **MD&A AND DESIGN**. MECHANICAL DYNAMICS AND ANALYSIS, LTD., MULTIPLE CLASS, (INT. CLS. 37 AND 42), (U.S. CLS. 100, 101, 103 AND 106). SN 85-216,617. PUB. 6-7-2011. FILED 1-13-2011.
 4,015,511. **MFG (STANDARD CHARACTER)**. MOLDED FIBER GLASS COMPANIES, MULTIPLE CLASS, (INT. CLS. 37, 40 AND 42), (U.S. CLS. 100, 101, 103 AND 106). SN 85-219,609. PUB. 6-7-2011. FILED 1-18-2011.
 4,015,533. **CLIMATE MATTERS HEATING & AIR CONDITIONING, INC. (STANDARD CHARACTER)**. CLIMATE MATTERS HEATING AND AIR CONDITIONING, (U.S. CLS. 100, 103 AND 106). SN 85-220,308. PUB. 6-7-2011. FILED 1-18-2011.
 4,015,542. **LUCKY STAR CLEANERS AND DESIGN**. J. MOONEY INC., (U.S. CLS. 100, 103 AND 106). SN 85-220,775. PUB. 6-7-2011. FILED 1-19-2011.
 4,015,561. **THINK GREEN THINK AETNA BUILDING MAINTENANCE (STANDARD CHARACTER)**. AETNA BUILDING MAINTENANCE, INC., (U.S. CLS. 100, 103 AND 106). SN 85-221,068. PUB. 6-7-2011. FILED 1-19-2011.
 4,015,634. **RELIABLE ROOFING AND DESIGN**. ATLANTA'S RELIABLE ROOFING CO., DBA RELIABLE ROOFING, INC., (U.S. CLS. 100, 103 AND 106). SN 85-222,906. PUB. 6-7-2011. FILED 1-21-2011.
 4,015,717. **HKC AND DESIGN**. HILTON KENNEDY COMPANY, LLC, (U.S. CLS. 100, 103 AND 106). SN 85-227,560. PUB. 6-7-2011. FILED 1-27-2011.
 4,015,748 (*See Class 35 for this trademark*).
 4,015,834. **FUR-FUR-FURNACE (STANDARD CHARACTER)**. NEXSTAR, INC., (U.S. CLS. 100, 103 AND 106). SN 85-229,851. PUB. 6-7-2011. FILED 1-31-2011.
 4,015,862 (*See Class 36 for this trademark*).

4,015,978. **MR. TINKER (STANDARD CHARACTER)**. WOLF, MICHEL J., (U.S. CLS. 100, 103 AND 106). SN 85-232,200. PUB. 6-7-2011. FILED 2-2-2011.

4,015,991. **CHANGING THE ENERGY PARADIGM. SMARTER. (STANDARD CHARACTER)**. METADIGM SERVICES, INC., (U.S. CLS. 100, 103 AND 106). SN 85-232,429. PUB. 6-7-2011. FILED 2-2-2011.

4,016,003 (*See Class 36 for this trademark*).

4,016,090 (*See Class 36 for this trademark*).

CLASS 38—COMMUNICATION

4,014,267 (*See Class 35 for this trademark*).

4,014,270. **M CLUB. NINTENDO AND DESIGN**. NINTENDO OF AMERICA INC., (U.S. CLS. 100, 101 AND 104). SN 77-583,819. PUB. 11-23-2010. FILED 10-2-2008.

4,014,278 (*See Class 35 for this trademark*).

4,014,291 (*See Class 35 for this trademark*).

4,014,303 (*See Class 35 for this trademark*).

4,014,316 (*See Class 9 for this trademark*).

4,014,317 (*See Class 9 for this trademark*).

4,014,336 (*See Class 9 for this trademark*).

4,014,348 (*See Class 7 for this trademark*).

4,014,383 (*See Class 9 for this trademark*).

4,014,395 (*See Class 9 for this trademark*).

4,014,425 (*See Class 9 for this trademark*).

4,014,453 (*See Class 9 for this trademark*).

4,014,503 (*See Class 9 for this trademark*).

4,014,506 (*See Class 1 for this trademark*).

4,014,510 (*See Class 9 for this trademark*).

4,014,570 (*See Class 35 for this trademark*).

4,014,571 (*See Class 35 for this trademark*).

4,014,628 (*See Class 9 for this trademark*).

4,014,664 (*See Class 9 for this trademark*).

4,014,731 (*See Class 6 for this trademark*).

4,014,788 (*See Class 9 for this trademark*).

4,014,821. **PRAISE FM (STYLIZED)**. PRAISE BROADCASTING, AKA PRAISE FM, (U.S. CLS. 100, 101 AND 104). SN 85-075,640. PUB. 6-7-2011. FILED 7-1-2010.

4,014,857 (*See Class 35 for this trademark*).

4,014,908. **RTN RACETRACK TELEVISION NETWORK AND DESIGN**. RACETRACK TELEVISION NETWORK, LLC, MULTIPLE CLASS, (INT. CLS. 38 AND 41), (U.S. CLS. 100, 101, 104 AND 107). SN 85-093,589. PUB. 6-7-2011. FILED 7-27-2010.

4,014,952. **SINCLAIR BROADCAST GROUP (STANDARD CHARACTER)**. SINCLAIR BROADCAST GROUP, INC., (U.S. CLS. 100, 101 AND 104). SN 85-103,284. PUB. 6-7-2011. FILED 8-9-2010.

4,015,045 (*See Class 9 for this trademark*).

4,015,050. **DIAMOND (STANDARD CHARACTER)**. DELEGATA CORPORATION, (U.S. CLS. 100, 101 AND 104). SN 85-133,326. PUB. 6-7-2011. FILED 9-20-2010.

4,015,127 (*See Class 9 for this trademark*).

4,015,215. **J SAT INTERNATIONAL AND DESIGN**. SKY PERFECT JSAT CORPORATION, (U.S. CLS. 100, 101 AND 104). SN 85-182,515. PUB. 6-7-2011. FILED 11-22-2010.

4,015,247 (*See Class 35 for this trademark*).

4,015,259. **LISTEN2MYRADIO (STANDARD CHARACTER)**. WEBCODE LTD, (U.S. CLS. 100, 101 AND 104). SN 85-194,086. PUB. 6-7-2011. FILED S.R. 12-9-2010; AM. P.R. 4-21-2011.

4,015,301. **COMMUNITY HEALTH EXCHANGE COLLABORATIVE AND DESIGN**. SOUTHWEST GENERAL, (U.S. CLS. 100, 101 AND 104). SN 85-200,434. PUB. 6-7-2011. FILED 12-17-2010.

4,015,310. **LATALINK (STANDARD CHARACTER)**. SYNIVERSE TECHNOLOGIES, INC., (U.S. CLS. 100, 101 AND 104). SN 85-201,989. PUB. 6-7-2011. FILED 12-20-2010.

4,015,475 (*See Class 35 for this trademark*).

4,015,682. **MUSIC PLUG (STANDARD CHARACTER)**. NYON CONCEPTS LIMITED, (U.S. CLS. 100, 101 AND 104). SN 85-225,837. PUB. 6-7-2011. FILED 1-25-2011.

4,015,683 (*See Class 9 for this trademark*).

4,015,740. **TU SELECCIÓN (STANDARD CHARACTER)**. NYON CONCEPTS LIMITED, (U.S. CLS. 100, 101 AND

104). SN 85-228,498. PUB. 6-7-2011. FILED 1-28-2011.

4,015,747 (*See Class 35 for this trademark*).

4,015,761. **APENIMED (STANDARD CHARACTER)**. APENIMED, INC., MULTIPLE CLASS, (INT. CLS. 38 AND 42), (U.S. CLS. 100, 101 AND 104). SN 85-228,790. PUB. 6-7-2011. FILED 1-28-2011.

4,016,000. **LOVEOPOLIS (STANDARD CHARACTER)**. LOVEOPOLIS, INC., MULTIPLE CLASS, (INT. CLS. 38 AND 45), (U.S. CLS. 100, 101 AND 104). SN 85-232,552. PUB. 6-7-2011. FILED 2-2-2011.

4,016,130. **TAGORAMIC (STANDARD CHARACTER)**. MLB ADVANCED MEDIA, L.P., MULTIPLE CLASS, (INT. CLS. 38, 41 AND 45), (U.S. CLS. 100, 101, 104 AND 107). SN 85-281,175. PUB. 6-7-2011. FILED 3-30-2011.

CLASS 39—TRANSPORTATION AND STORAGE

4,014,220. **CHICAGO LIMOUSINE (STANDARD CHARACTER)**. CHICAGO LIMOUSINE, INC., (U.S. CLS. 100 AND 105). SN 76-704,561. PUB. 6-7-2011. FILED 9-20-2010.

4,014,267 (*See Class 35 for this trademark*).

4,014,303 (*See Class 35 for this trademark*).

4,014,345 (*See Class 37 for this trademark*).

4,014,386. **LIFEBANKUSA AND DESIGN**. CELGENE CORPORATION, MULTIPLE CLASS, (INT. CLS. 39 AND 44), (U.S. CLS. 100, 101 AND 105). SN 77-912,092. PUB. 6-7-2011. FILED 1-14-2010.

4,014,400 (*See Class 35 for this trademark*).

4,014,442 (*See Class 30 for this trademark*).

4,014,486 (*See Class 4 for this trademark*).

4,014,570 (*See Class 35 for this trademark*).

4,014,571 (*See Class 35 for this trademark*).

4,014,731 (*See Class 6 for this trademark*).

4,014,732 (*See Class 35 for this trademark*).

4,014,747. **OPEN HEALTH (STANDARD CHARACTER)**. OPEN HEALTH SERVICES CANADA LTD., (U.S. CLS. 100 AND 105). SN 85-056,681. PUB. 6-7-2011. FILED 6-7-2010.

4,014,882 (*See Class 35 for this trademark*).

4,014,893 (*See Class 35 for this trademark*).

4,014,947. **INTEGREON (STANDARD CHARACTER)**. INTEGREON, INC., (U.S. CLS. 100 AND 105). SN 85-101,296. PUB. 6-7-2011. FILED 8-5-2010.

4,014,948. **INTEGREON AND DESIGN**. INTEGREON, INC., (U.S. CLS. 100 AND 105). SN 85-101,371. PUB. 6-7-2011. FILED 8-5-2010.

4,014,979. **MISCELLANEOUS DESIGN**. A & M TRANSPORT, INC., (U.S. CLS. 100 AND 105). SN 85-111,133. PUB. 6-7-2011. FILED 8-19-2010.

4,015,029. **MMRGLOBAL (STANDARD CHARACTER)**. MMRGLOBAL, INC., (U.S. CLS. 100 AND 105). SN 85-125,782. PUB. 6-7-2011. FILED 9-9-2010.

4,015,060 (*See Class 35 for this trademark*).

4,015,082 (*See Class 37 for this trademark*).

4,015,102. **WILLOW CLUB AND DESIGN**. WILLOW LIFESTYLE CLUBS LLC, MULTIPLE CLASS, (INT. CLS. 39, 41 AND 43), (U.S. CLS. 100, 101, 105 AND 107). SN 85-148,156. PUB. 6-7-2011. FILED 10-8-2010.

4,015,103. **CAMPUS NANNY (STANDARD CHARACTER)**. NEW HORIZON INDUSTRIES, INC., (U.S. CLS. 100 AND 105). SN 85-148,457. PUB. 6-7-2011. FILED 10-8-2010.

4,015,105. **RELIABLE DELIVERY (858)272.2084 AND DESIGN**. RELIABLE DELIVERY LLC, (U.S. CLS. 100 AND 105). SN 85-149,595. PUB. 6-7-2011. FILED 10-11-2010.

4,015,173. **MMRPRO (STANDARD CHARACTER)**. MYMEDICALRECORDS, INC., (U.S. CLS. 100 AND 105). SN 85-170,350. PUB. 6-7-2011. FILED 11-5-2010.

4,015,174. **MMRPRO AND DESIGN**. MYMEDICALRECORDS, INC., (U.S. CLS. 100 AND 105). SN 85-170,422. PUB. 6-7-2011. FILED 11-5-2010.

4,015,213 (*See Class 35 for this trademark*).

4,015,260 (*See Class 35 for this trademark*).

4,015,493. **BARKER THE PARKER (STANDARD CHARACTER)**. BRADLEY AIRPORT VALET PARKING INC., DBA EXECUTIVE VALET PARKING, (U.S. CLS. 100 AND 105). SN 85-219,067. PUB. 6-7-2011. FILED 1-17-2011.

4,015,594 (*See Class 4 for this trademark.*)
 4,015,596 (*See Class 4 for this trademark.*)
 4,015,599 (*See Class 35 for this trademark.*)
 4,015,747 (*See Class 35 for this trademark.*)
 4,015,760. **ALL WAYS MOVING & STORAGE (STANDARD CHARACTER)**. MCKEAN & BURT, INC., DBA ALL WAYS MOVING & STORAGE, (U.S. CLS. 100 AND 105). SN 85-228,783. PUB. 6-7-2011. FILED 1-28-2011.
 4,015,809 (*See Class 35 for this trademark.*)
 4,015,838. **MACROTRANSPORT SERVICES (STANDARD CHARACTER)**. MACROTRANSPORT SERVICES, LLC, (U.S. CLS. 100 AND 105). SN 85-229,873. PUB. 6-7-2011. FILED 1-31-2011.

CLASS 40—MATERIAL TREATMENT

4,014,267 (*See Class 35 for this trademark.*)
 4,014,283. **LMS AND DESIGN**. LIQUID MEASUREMENT SYSTEMS, INC., MULTIPLE CLASS, (INT. CLS. 40 AND 42), (U.S. CLS. 100, 101, 103 AND 106). SN 77-632,725. PUB. 8-18-2009. FILED 12-14-2008.
 4,014,328. **EP AND DESIGN**. ELEMENT POWER HOLDINGS LP, (U.S. CLS. 100, 103 AND 106). SN 77-808,172. PUB. 6-7-2011. FILED 8-19-2009.
 4,014,340 (*See Class 35 for this trademark.*)
 4,014,406. **MELTFLIPPER AND DESIGN**. BEAUMONT RUNNER TECHNOLOGIES, INC., (U.S. CLS. 100, 103 AND 106). SN 77-942,588. PUB. 6-7-2011. FILED 2-23-2010.
 4,014,492 (*See Class 29 for this trademark.*)
 4,014,570 (*See Class 35 for this trademark.*)
 4,014,571 (*See Class 35 for this trademark.*)
 4,014,577 (*See Class 7 for this trademark.*)
 4,014,638. **LUXIMPRESS (STANDARD CHARACTER)**. LUX-EXCEL HOLDING B.V., (U.S. CLS. 100, 103 AND 106). SN 79-092,891. PUB. 6-7-2011. FILED 10-15-2010.
 4,014,686. **SPAULDING DECON AND DESIGN**. SPAULDING DECON, LLC, (U.S. CLS. 100, 103 AND 106). SN 85-028,401. PUB. 6-7-2011. FILED 5-3-2010.
 4,014,805. **NOW THAT'S THINKING BEYOND TODAY (STANDARD CHARACTER)**. PWP INDUSTRIES, INC., (U.S. CLS. 100, 103 AND 106). SN 85-072,899. PUB. 6-7-2011. FILED 6-28-2010.
 4,014,917. **ECOLAB (STANDARD CHARACTER)**. ECOLAB USA INC., (U.S. CLS. 100, 103 AND 106). SN 85-094,729. PUB. 5-3-2011. FILED 7-28-2010.
 4,014,945 (*See Class 37 for this trademark.*)
 4,014,992 (*See Class 37 for this trademark.*)
 4,015,086 (*See Class 37 for this trademark.*)
 4,015,111 (*See Class 35 for this trademark.*)
 4,015,147. **STARNET (STANDARD CHARACTER)**. STARNET BUSINESS SOLUTIONS, INC., (U.S. CLS. 100, 103 AND 106). SN 85-162,542. PUB. 6-7-2011. FILED 10-27-2010.
 4,015,152. **PLAYTUFF (STANDARD CHARACTER)**. PLAY-TIME LLC, (U.S. CLS. 100, 103 AND 106). SN 85-164,116. PUB. 6-7-2011. FILED 10-28-2010.
 4,015,166. **CRYSTAL ICING (STANDARD CHARACTER)**. CRYSTAL ICING, LLC, (U.S. CLS. 100, 103 AND 106). SN 85-168,261. PUB. 6-7-2011. FILED 11-3-2010.
 4,015,204 (*See Class 1 for this trademark.*)
 4,015,404 (*See Class 25 for this trademark.*)
 4,015,477. **COOL STICK (STYLIZED)**. COOL STICK LA-CROSSE LLC, (U.S. CLS. 100, 103 AND 106). SN 85-218,384. PUB. 6-7-2011. FILED 1-14-2011.
 4,015,511 (*See Class 37 for this trademark.*)
 4,015,667. **WITCH CREEK WINERY (STANDARD CHARACTER)**. WITCH CREEK WINERY, (U.S. CLS. 100, 103 AND 106). SN 85-224,948. PUB. 6-7-2011. FILED 1-24-2011.
 4,015,797. **GO GREEN WITH A COLD CLEAN! (STANDARD CHARACTER)**. THE SERGIO CORPORATION, DBA FIRST RESPONSE DISASTER RESTORATION, (U.S. CLS. 100, 103 AND 106). SN 85-229,216. PUB. 6-7-2011. FILED 1-28-2011.

CLASS 41—EDUCATION AND ENTERTAINMENT

4,014,224. **PERFORMANCE TRUST UNIVERSITY (STANDARD CHARACTER)**. PT FINANCIAL, LLC, (U.S. CLS. 100, 101 AND 107). SN 76-705,472. PUB. 6-7-2011. FILED 11-26-2010.
 4,014,226. **NORTHCENTRAL UNIVERSITY (STANDARD CHARACTER)**. NORTHCENTRAL UNIVERSITY, INC., (U.S. CLS. 100, 101 AND 107). SN 76-705,911. PUB. 6-7-2011. FILED 1-6-2011.
 4,014,228. **LIFE COACHING WITH THE ARCHANGELS (STANDARD CHARACTER)**. GABRIEL TIRADO, (U.S. CLS. 100, 101 AND 107). SN 76-706,176. PUB. 6-7-2011. FILED 1-31-2011.
 4,014,241. **EQUIP (STANDARD CHARACTER)**. CSAFE, LLC, (U.S. CLS. 100, 101 AND 107). SN 76-706,301. PUB. 6-7-2011. FILED 2-7-2011.
 4,014,242. **HEALTHY ZONE SCHOOL RECOGNITION PROGRAM (STANDARD CHARACTER)**. THE COOPER INSTITUTE, (U.S. CLS. 100, 101 AND 107). SN 76-706,425. PUB. 6-7-2011. FILED 2-16-2011.
 4,014,249 (*See Class 16 for this trademark.*)
 4,014,253 (*See Class 9 for this trademark.*)
 4,014,254 (*See Class 9 for this trademark.*)
 4,014,271 (*See Class 9 for this trademark.*)
 4,014,278 (*See Class 35 for this trademark.*)
 4,014,279 (*See Class 16 for this trademark.*)
 4,014,282. **INDEPENDENT LENS (STANDARD CHARACTER)**. PUBLIC BROADCASTING SERVICE, (U.S. CLS. 100, 101 AND 107). SN 77-620,758. PUB. 6-7-2011. FILED 11-24-2008.
 4,014,291 (*See Class 35 for this trademark.*)
 4,014,297. **COUCH POTATO (STANDARD CHARACTER)**. BAY CITY TELEVISION, INC., (U.S. CLS. 100, 101 AND 107). SN 77-694,064. PUB. 6-7-2011. FILED 3-18-2009.
 4,014,303 (*See Class 35 for this trademark.*)
 4,014,313 (*See Class 16 for this trademark.*)
 4,014,315 (*See Class 9 for this trademark.*)
 4,014,316 (*See Class 9 for this trademark.*)
 4,014,317 (*See Class 9 for this trademark.*)
 4,014,318. **FEEL THE MUSIC! (STANDARD CHARACTER)**. WORLD FOUNDATION FOR MUSIC AND HEALING, (U.S. CLS. 100, 101 AND 107). SN 77-764,953. PUB. 6-7-2011. FILED 6-22-2009.
 4,014,321 (*See Class 35 for this trademark.*)
 4,014,327 (*See Class 3 for this trademark.*)
 4,014,336 (*See Class 9 for this trademark.*)
 4,014,337 (*See Class 6 for this trademark.*)
 4,014,339. **MISCELLANEOUS DESIGN**. AFRIKAN DESCENT YOUTH AFFAIRS (ADYA), DBA ADYA, (U.S. CLS. 100, 101 AND 107). SN 77-829,237. PUB. 6-7-2011. FILED 9-17-2009.
 4,014,351. **CRITICAL PATH TRAINING AND DESIGN**. CRITICAL PATH TRAINING, LLC, (U.S. CLS. 100, 101 AND 107). SN 77-859,527. PUB. 4-20-2010. FILED 10-28-2009.
 4,014,374. **STANDUP WORLD TOUR AND DESIGN**. WATERMAN LEAGUE LTD., (U.S. CLS. 100, 101 AND 107). SN 77-894,217. PUB. 6-7-2011. FILED 12-15-2009.
 4,014,375. **SCENAR HEALTH USA AND DESIGN**. SCENAR HEALTH USA LLC, (U.S. CLS. 100, 101 AND 107). SN 77-894,829. PUB. 6-7-2011. FILED 12-16-2009.
 4,014,377. **LIBERTY CARTER (STANDARD CHARACTER)**. MELANIE P HILL, (U.S. CLS. 100, 101 AND 107). SN 77-902,514. PUB. 6-7-2011. FILED 12-29-2009.
 4,014,381 (*See Class 35 for this trademark.*)
 4,014,394 (*See Class 35 for this trademark.*)
 4,014,395 (*See Class 9 for this trademark.*)
 4,014,403 (*See Class 16 for this trademark.*)
 4,014,410 (*See Class 35 for this trademark.*)
 4,014,411 (*See Class 9 for this trademark.*)
 4,014,416 (*See Class 35 for this trademark.*)
 4,014,427. **UNWIGGED & UNPLUGGED (STANDARD CHARACTER)**. CENTURY OF PROGRESS PRODUCTIONS, (U.S. CLS. 100, 101 AND 107). SN 77-981,895. PUB. 6-7-2011. FILED 11-16-2009.
 4,014,439 (*See Class 28 for this trademark.*)
 4,014,444 (*See Class 9 for this trademark.*)
 4,014,458 (*See Class 9 for this trademark.*)
 4,014,459 (*See Class 35 for this trademark.*)

- 4,014,477. **MPOINT (STYLIZED)**. 24SNAILS A.S., (U.S. CLS. 100, 101 AND 107). SN 79-079,039. PUB. 6-7-2011. FILED 8-7-2009.
- 4,014,479 (*See Class 9 for this trademark*).
- 4,014,483 (*See Class 16 for this trademark*).
- 4,014,489 (*See Class 16 for this trademark*).
- 4,014,494 (*See Class 9 for this trademark*).
- 4,014,503 (*See Class 9 for this trademark*).
- 4,014,506 (*See Class 1 for this trademark*).
- 4,014,510 (*See Class 9 for this trademark*).
- 4,014,536 (*See Class 36 for this trademark*).
- 4,014,553 (*See Class 35 for this trademark*).
- 4,014,566. **FED FONDAZIONE EUROPEA DRAGAN (STANDARD CHARACTER)**. DANIELA VERONICA GUSA DE DRAGAN, (U.S. CLS. 100, 101 AND 107). SN 79-087,437. PUB. 6-7-2011. FILED 8-4-2010.
- 4,014,570 (*See Class 35 for this trademark*).
- 4,014,571 (*See Class 35 for this trademark*).
- 4,014,585. **YOLANTE (STANDARD CHARACTER)**. SIEMENS AKTIENGESSELLSCHAFT, (U.S. CLS. 100, 101 AND 107). SN 79-089,021. PUB. 6-7-2011. FILED 7-21-2010.
- 4,014,593 (*See Class 9 for this trademark*).
- 4,014,599 (*See Class 9 for this trademark*).
- 4,014,634 (*See Class 25 for this trademark*).
- 4,014,649 (*See Class 11 for this trademark*).
- 4,014,677 (*See Class 9 for this trademark*).
- 4,014,684. **DAN MAR ANTIMICROBIAL INTERVENTION SYSTEMS AND DESIGN**. DAN MAR CO., (U.S. CLS. 100, 101 AND 107). SN 85-025,776. PUB. 6-7-2011. FILED 4-28-2010.
- 4,014,687. **ARTSEMERSON (STANDARD CHARACTER)**. EMERSON COLLEGE, (U.S. CLS. 100, 101 AND 107). SN 85-029,531. PUB. 6-7-2011. FILED 5-4-2010.
- 4,014,688. **ARTS EMERSON AND DESIGN**. EMERSON COLLEGE, (U.S. CLS. 100, 101 AND 107). SN 85-029,558. PUB. 6-7-2011. FILED 5-4-2010.
- 4,014,689. **THE WORLD ON STAGE (STANDARD CHARACTER)**. EMERSON COLLEGE, (U.S. CLS. 100, 101 AND 107). SN 85-029,565. PUB. 6-7-2011. FILED 5-4-2010.
- 4,014,697. **YOU MAKE IT. THEY TAKE IT. (STANDARD CHARACTER)**. FOX NEWS NETWORK, LLC, (U.S. CLS. 100, 101 AND 107). SN 85-035,695. PUB. 6-7-2011. FILED 5-11-2010.
- 4,014,698. **YOU MAKE IT. THEY TAKE IT AND DESIGN**. FOX NEWS NETWORK, LLC, (U.S. CLS. 100, 101 AND 107). SN 85-035,719. PUB. 6-7-2011. FILED 5-11-2010.
- 4,014,699. **HORSES FOR HEROES AND DESIGN**. HORSE-S4HEROES, INC., (U.S. CLS. 100, 101 AND 107). SN 85-036,301. PUB. 6-7-2011. FILED 5-12-2010.
- 4,014,708. **BMCARE AND DESIGN**. BIOSTIME, INC. (GUANGZHOU), (U.S. CLS. 100, 101 AND 107). SN 85-039,532. PUB. 3-1-2011. FILED 5-15-2010.
- 4,014,710 (*See Class 9 for this trademark*).
- 4,014,711 (*See Class 9 for this trademark*).
- 4,014,724. **SISTERS EMPOWERING SISTERS (SES) (STANDARD CHARACTER)**. THE IMAGE INITIATIVE, INC., (U.S. CLS. 100, 101 AND 107). SN 85-049,918. PUB. 6-7-2011. FILED 5-27-2010.
- 4,014,726. **EARN YOUR STRIPES (STANDARD CHARACTER)**. TGI FRIDAY'S OF MINNESOTA, INC., (U.S. CLS. 100, 101 AND 107). SN 85-050,537. PUB. 5-3-2011. FILED 5-28-2010.
- 4,014,727. **PROJECT PENNSYLVANIA MINDFUL CHANGE (STANDARD CHARACTER)**. WILSON, LAURIE, (U.S. CLS. 100, 101 AND 107). SN 85-050,677. PUB. 6-7-2011. FILED 5-28-2010.
- 4,014,729 (*See Class 9 for this trademark*).
- 4,014,731 (*See Class 6 for this trademark*).
- 4,014,733. **EMPIRE CITY CASINO (STANDARD CHARACTER)**. YONKERS RACING CORPORATION, (U.S. CLS. 100, 101 AND 107). SN 85-052,007. PUB. 6-7-2011. FILED 6-1-2010.
- 4,014,735. **MISCELLANEOUS DESIGN**. PRITCHARD, LISA, AND PRITCHARD, BRIAN K., (U.S. CLS. 100, 101 AND 107). SN 85-052,927. PUB. 6-7-2011. FILED 6-2-2010.
- 4,014,743 (*See Class 35 for this trademark*).
- 4,014,777 (*See Class 9 for this trademark*).
- 4,014,778 (*See Class 9 for this trademark*).
- 4,014,786. **CHALLENGER REP (STANDARD CHARACTER)**. THE CORPORATE EXECUTIVE BOARD CO., (U.S. CLS. 100, 101 AND 107). SN 85-067,809. PUB. 6-7-2011. FILED 6-21-2010.
- 4,014,788 (*See Class 9 for this trademark*).
- 4,014,794. **UNsung HEROES (STANDARD CHARACTER)**. SEARS BRANDS, LLC, (U.S. CLS. 100, 101 AND 107). SN 85-070,482. PUB. 6-7-2011. FILED 6-24-2010.
- 4,014,799. **BALLS (STANDARD CHARACTER)**. TRIPOLI ROCKETRY ASSOCIATION, INC., (U.S. CLS. 100, 101 AND 107). SN 85-071,112. PUB. 6-7-2011. FILED 6-24-2010.
- 4,014,802. **SC SCHOOLCARE COVENANT CLASSICAL SCHOOL & DAYCARE AND DESIGN**. COVENANT CLASSICAL SCHOOLS, LLC, MULTIPLE CLASS, (INT. CLS. 41 AND 43), (U.S. CLS. 100, 101 AND 107). SN 85-071,606. PUB. 6-7-2011. FILED 6-25-2010.
- 4,014,804 (*See Class 16 for this trademark*).
- 4,014,820. **RECOVERING EVANGELICAL (STANDARD CHARACTER)**. LATONDRESSE, JEAN CHRISTOPHER, (U.S. CLS. 100, 101 AND 107). SN 85-075,604. PUB. 6-7-2011. FILED 7-1-2010.
- 4,014,822. **BUG (STYLIZED)**. ROLLINSON, PHILIP GARRETT, (U.S. CLS. 100, 101 AND 107). SN 85-075,687. PUB. 6-7-2011. FILED 7-1-2010.
- 4,014,829. **POP BIZ (STANDARD CHARACTER)**. MINYANVILLE PUBLISHING & MULTIMEDIA, LLC, (U.S. CLS. 100, 101 AND 107). SN 85-076,233. PUB. 6-7-2011. FILED 7-1-2010.
- 4,014,836 (*See Class 25 for this trademark*).
- 4,014,841. **LE LEJAN ENTERTAINMENT AND DESIGN**. LEJAN ENTERTAINMENT INC, (U.S. CLS. 100, 101 AND 107). SN 85-079,442. PUB. 6-7-2011. FILED 7-7-2010.
- 4,014,861 (*See Class 25 for this trademark*).
- 4,014,865. **ASK THE DUFFER (STANDARD CHARACTER)**. DUFF, ROBERT ALEXANDER, (U.S. CLS. 100, 101 AND 107). SN 85-084,039. PUB. 6-7-2011. FILED 7-14-2010.
- 4,014,872. **SPIRITUALIZING THROUGH A GOOD PHYSICAL CONSCIENCE (STANDARD CHARACTER)**. PAUL FANNY, (U.S. CLS. 100, 101 AND 107). SN 85-086,291. PUB. 6-7-2011. FILED 7-16-2010.
- 4,014,873. **ECCLESIOLOGY SPIRITUAL, BUT NOT RELIGIOUS (STANDARD CHARACTER)**. PAUL FANNY, (U.S. CLS. 100, 101 AND 107). SN 85-086,319. PUB. 6-7-2011. FILED 7-16-2010.
- 4,014,874. **ANATOMY OF SPIRITUALITY (STANDARD CHARACTER)**. PAUL FANNY, (U.S. CLS. 100, 101 AND 107). SN 85-086,362. PUB. 6-7-2011. FILED 7-16-2010.
- 4,014,886. **STRAIGHT TO THE HEART OF WHAT MATTERS (STANDARD CHARACTER)**. DEBORAH S. HOWELL, (U.S. CLS. 100, 101 AND 107). SN 85-089,137. PUB. 6-7-2011. FILED 7-21-2010.
- 4,014,889. **AK-SAR-BEN'S RIVER CITY RODEO & STOCK SHOW (STANDARD CHARACTER)**. KNIGHTS OF AK-SAR-BEN FOUNDATION, (U.S. CLS. 100, 101 AND 107). SN 85-090,190. PUB. 6-7-2011. FILED 7-22-2010.
- 4,014,895 (*See Class 35 for this trademark*).
- 4,014,896. **BELLA TERRA (STANDARD CHARACTER)**. SCHNEIDER, JEFFREY, (U.S. CLS. 100, 101 AND 107). SN 85-091,593. PUB. 2-1-2011. FILED 7-23-2010.
- 4,014,898. **WILD ON WOUNDS (STANDARD CHARACTER)**. WOUND CARE EDUCATION INSTITUTE, INC., (U.S. CLS. 100, 101 AND 107). SN 85-091,868. PUB. 6-7-2011. FILED 7-23-2010.
- 4,014,899 (*See Class 9 for this trademark*).
- 4,014,903. **RUNNING MOMS ROCK (STANDARD CHARACTER)**. RUNNING MOMS ROCK LLC, (U.S. CLS. 100, 101 AND 107). SN 85-092,816. PUB. 6-7-2011. FILED 7-26-2010.
- 4,014,907. **COMPOSTMODERN (STANDARD CHARACTER)**. AMERICAN INSTITUTE OF GRAPHIC ARTS-SAN FRANCISCO CHAPTER, AKA AIGA SAN FRANCISCO, (U.S. CLS. 100, 101 AND 107). SN 85-093,238. PUB. 6-7-2011. FILED 7-26-2010.
- 4,014,908 (*See Class 38 for this trademark*).
- 4,014,922 (*See Class 16 for this trademark*).
- 4,014,926. **CHIPLESS BLACKJACK BARONA AND DESIGN**. BARONA GROUP OF THE CAPITAN GRANDE BAND OF MISSION INDIANS, DBA BARONA VALLEY RANCH RESORT AND CASINO, (U.S. CLS. 100, 101 AND 107). SN

- 85-095,785. PUB. 6-7-2011. FILED 7-29-2010.
- 4,014,927. **CHIPLESS BACCARAT BARONA AND DESIGN.** BARONA GROUP OF THE CAPITAN GRANDE BAND OF MISSION INDIANS, DBA BARONA VALLEY RANCH RESORT AND CASINO, (U.S. CLS. 100, 101 AND 107). SN 85-095,787. PUB. 6-7-2011. FILED 7-29-2010.
- 4,014,928. **CHIPLESS ROULETTE BARONA AND DESIGN.** BARONA GROUP OF THE CAPITAN GRANDE BAND OF MISSION INDIANS, DBA BARONA VALLEY RANCH RESORT AND CASINO, (U.S. CLS. 100, 101 AND 107). SN 85-095,794. PUB. 6-7-2011. FILED 7-29-2010.
- 4,014,929. **CHIPLESS! A WHOLE NEW WAY TO PLAY. (STANDARD CHARACTER).** BARONA GROUP OF THE CAPITAN GRANDE BAND OF MISSION INDIANS, DBA BARONA VALLEY RANCH RESORT AND CASINO, (U.S. CLS. 100, 101 AND 107). SN 85-095,851. PUB. 6-7-2011. FILED 7-29-2010.
- 4,014,933. **CUTTINGEDGESCIENCE AND DESIGN.** NATIONAL NETWORK OF DIGITAL SCHOOLS MANAGEMENT FOUNDATION, (U.S. CLS. 100, 101 AND 107). SN 85-097,242. PUB. 6-7-2011. FILED 7-30-2010.
- 4,014,936. **MAMAPOP (STANDARD CHARACTER).** MAMAPOP LLC, (U.S. CLS. 100, 101 AND 107). SN 85-099,115. PUB. 6-7-2011. FILED 8-3-2010.
- 4,014,981. **CATA9TALES (STANDARD CHARACTER).** PRIEST, JAMES BERKLEY, (U.S. CLS. 100, 101 AND 107). SN 85-112,818. PUB. 6-7-2011. FILED 8-20-2010.
- 4,014,984. **THE BIODESIGN INSTITUTE AT ARIZONA STATE UNIVERSITY (STANDARD CHARACTER).** ARIZONA BOARD OF REGENTS, FOR AND ON BEHALF OF ARIZONA STATE UNIVERSITY, (U.S. CLS. 100, 101 AND 107). SN 85-115,404. PUB. 6-7-2011. FILED 8-25-2010.
- 4,014,985. **ASU BIODESIGN INSTITUTE ARIZONA STATE UNIVERSITY AND DESIGN.** ARIZONA BOARD OF REGENTS, FOR AND ON BEHALF OF ARIZONA STATE UNIVERSITY, (U.S. CLS. 100, 101 AND 107). SN 85-115,443. PUB. 6-7-2011. FILED 8-25-2010.
- 4,014,986. **DAILYFEATS (STANDARD CHARACTER).** VMCS, INC., (U.S. CLS. 100, 101 AND 107). SN 85-115,611. PUB. 6-7-2011. FILED 8-25-2010.
- 4,014,994 (*See Class 9 for this trademark*).
- 4,014,996. **ENDOVASCULAR SURGERY CENTER OF EXCELLENCE (STANDARD CHARACTER).** ACCREDITATION COUNCIL FOR SURGICAL QUALITY, (U.S. CLS. 100, 101 AND 107). SN 85-120,147. PUB. 6-7-2011. FILED 8-31-2010.
- 4,014,998. **LISTENING PROJECT (STANDARD CHARACTER).** RURAL SOUTHERN VOICE FOR PEACE, (U.S. CLS. 100, 101 AND 107). SN 85-120,438. PUB. 6-7-2011. FILED 9-1-2010.
- 4,015,008 (*See Class 36 for this trademark*).
- 4,015,023 (*See Class 9 for this trademark*).
- 4,015,024. **ENGAGE SUMMIT (STANDARD CHARACTER).** ALLEGIANCE SOFTWARE, INC., (U.S. CLS. 100, 101 AND 107). SN 85-124,289. PUB. 6-7-2011. FILED 9-7-2010.
- 4,015,032. **SCHOLASTIC BIG DAY FOR PREK AND DESIGN.** SCHOLASTIC INC., (U.S. CLS. 100, 101 AND 107). SN 85-126,797. PUB. 6-7-2011. FILED 9-10-2010.
- 4,015,036. **WF (STYLIZED).** WAKE FOREST UNIVERSITY, (U.S. CLS. 100, 101 AND 107). SN 85-128,263. PUB. 6-7-2011. FILED 9-13-2010.
- 4,015,045 (*See Class 9 for this trademark*).
- 4,015,046. **KNIGHT CANCER INSTITUTE (STANDARD CHARACTER).** OREGON HEALTH & SCIENCE UNIVERSITY, (U.S. CLS. 100, 101 AND 107). SN 85-130,550. PUB. 6-7-2011. FILED 9-15-2010.
- 4,015,062. **PHOENIX RISING YOGA THERAPY (STANDARD CHARACTER).** LEE, MICHAEL, (U.S. CLS. 100, 101 AND 107). SN 85-137,459. PUB. 6-7-2011. FILED 9-24-2010.
- 4,015,068. **REBEL ROCK PRODUCTIONS (STANDARD CHARACTER).** REBEL ROCK PRODUCTIONS, INC., (U.S. CLS. 100, 101 AND 107). SN 85-138,859. PUB. 6-7-2011. FILED 9-27-2010.
- 4,015,071 (*See Class 9 for this trademark*).
- 4,015,087. **OPTIMIZED BITE (STANDARD CHARACTER).** CHAN, CLAYTON A., (U.S. CLS. 100, 101 AND 107). SN 85-143,060. PUB. 6-7-2011. FILED 10-1-2010.
- 4,015,090 (*See Class 16 for this trademark*).
- 4,015,093. **WELL M@IL (STANDARD CHARACTER).** PHARMACA INTEGRATIVE PHARMACY, INC., MULTIPLE CLASS, (INT. CLS. 41 AND 44), (U.S. CLS. 100, 101 AND 107). SN 85-145,773. PUB. 6-7-2011. FILED 10-5-2010.
- 4,015,095. **MIA'S SHOW (STANDARD CHARACTER).** TREE HOME MEDIA, (U.S. CLS. 100, 101 AND 107). SN 85-146,414. PUB. 6-7-2011. FILED 10-6-2010.
- 4,015,099. **SMOOCHES FULL FIGURED & PLUS SIZE MODELING PROGRAM AND DESIGN.** DARRYL BRADLEY, AND CHANTE M. BRADLEY, (U.S. CLS. 100, 101 AND 107). SN 85-147,623. PUB. 6-7-2011. FILED 10-7-2010.
- 4,015,101. **MISCELLANEOUS DESIGN.** TREE HOME MEDIA, (U.S. CLS. 100, 101 AND 107). SN 85-148,086. PUB. 6-7-2011. FILED 10-8-2010.
- 4,015,102 (*See Class 39 for this trademark*).
- 4,015,107. **ATSSA SAFER ROADS SAVE LIVES TRAFFIC EXPO AND DESIGN.** AMERICAN TRAFFIC SAFETY SERVICES ASSOCIATION, INC., (U.S. CLS. 100, 101 AND 107). SN 85-149,679. PUB. 6-7-2011. FILED 10-11-2010.
- 4,015,113. **UNBRIDLED PHOTOGRAPHY (STANDARD CHARACTER).** PATTERSON, DEBBIE, (U.S. CLS. 100, 101 AND 107). SN 85-152,136. PUB. 6-7-2011. FILED 10-13-2010.
- 4,015,115 (*See Class 9 for this trademark*).
- 4,015,119. **DO GOOD. CHECK IT IN. (STANDARD CHARACTER).** VMCS, INC., (U.S. CLS. 100, 101 AND 107). SN 85-154,248. PUB. 6-7-2011. FILED 10-15-2010.
- 4,015,140. **ORGASMIC MEDITATION (STANDARD CHARACTER).** CARAVAN RETREATS INCORPORATED, (U.S. CLS. 100, 101 AND 107). SN 85-159,647. PUB. 6-7-2011. FILED 10-23-2010.
- 4,015,145. **E & L (STYLIZED).** ETIQUETTE AND LEADERSHIP INSTITUTE, LLC, (U.S. CLS. 100, 101 AND 107). SN 85-161,676. PUB. 6-7-2011. FILED 10-26-2010.
- 4,015,146. **SKYDIVE KY (STANDARD CHARACTER).** SKYDIVE KY LLC, (U.S. CLS. 100, 101 AND 107). SN 85-162,419. PUB. 6-7-2011. FILED 10-27-2010.
- 4,015,149. **MELVIN SEALS & JGB (STANDARD CHARACTER).** SEALS, MELVIN, (U.S. CLS. 100, 101 AND 107). SN 85-163,161. PUB. 6-7-2011. FILED 10-27-2010.
- 4,015,150 (*See Class 14 for this trademark*).
- 4,015,153 (*See Class 16 for this trademark*).
- 4,015,155. **MARIANA DE LA NOCHE AND DESIGN.** TELEVISA, S.A. DE C.V., (U.S. CLS. 100, 101 AND 107). SN 85-164,582. PUB. 6-7-2011. FILED 10-29-2010.
- 4,015,158. **FEATS (STANDARD CHARACTER).** VMCS, INC., (U.S. CLS. 100, 101 AND 107). SN 85-166,781. PUB. 6-7-2011. FILED 11-2-2010.
- 4,015,161. **GLOBAL VENTURE CAPITAL CONGRESS AND DESIGN.** NORTH STAR VENTURE MANAGEMENT 2000, LLC, (U.S. CLS. 100, 101 AND 107). SN 85-167,467. PUB. 6-7-2011. FILED 11-2-2010.
- 4,015,182. **SC SONIDO COSTEÑO AND DESIGN.** SONCREW PRODUCTIONS, INC, DBA SONIDO COSTEÑO, (U.S. CLS. 100, 101 AND 107). SN 85-172,753. PUB. 6-7-2011. FILED 11-9-2010.
- 4,015,189. **MASTERCAM U (STYLIZED).** CNC SOFTWARE, INC., (U.S. CLS. 100, 101 AND 107). SN 85-175,298. PUB. 6-7-2011. FILED 11-12-2010.
- 4,015,198. **GCFLATINO.ORG AND DESIGN.** GOODWILL COMMUNITY FOUNDATION, INC., (U.S. CLS. 100, 101 AND 107). SN 85-177,576. PUB. 6-7-2011. FILED 11-16-2010.
- 4,015,202 (*See Class 35 for this trademark*).
- 4,015,206 (*See Class 16 for this trademark*).
- 4,015,210. **JOYOLOGIE (STANDARD CHARACTER).** JOYOLOGIE, LLC, (U.S. CLS. 100, 101 AND 107). SN 85-180,166. PUB. 6-7-2011. FILED 11-18-2010.
- 4,015,218 (*See Class 35 for this trademark*).
- 4,015,219 (*See Class 35 for this trademark*).
- 4,015,232. **SHAMROCK THE BLOCK AND DESIGN.** THREE ONE ONE, (U.S. CLS. 100, 101 AND 107). SN 85-186,451. PUB. 6-7-2011. FILED 11-29-2010.
- 4,015,233 (*See Class 35 for this trademark*).
- 4,015,247 (*See Class 35 for this trademark*).
- 4,015,253. **FALKEN ARTS PRODUCTIONS AND DESIGN.** FALKEN ARTS PRODUCTIONS, (U.S. CLS. 100, 101 AND 107). SN 85-192,530. PUB. 6-7-2011. FILED 12-7-2010.
- 4,015,254. **THE SHARK TANK AND DESIGN.** SHARK TANK MEDIA LLC, (U.S. CLS. 100, 101 AND 107). SN 85-192,708.

- PUB. 6-7-2011. FILED 12-7-2010.
4,015,258 (*See Class 35 for this trademark*).
- 4,015,261. **SACRAMENTO REGIONAL DRIVER TRAINING AUTHORITY AND DESIGN**. CITY OF SACRAMENTO, (U.S. CLS. 100, 101 AND 107). SN 85-194,609. PUB. 6-7-2011. FILED 12-9-2010.
- 4,015,277 (*See Class 35 for this trademark*).
- 4,015,282. **ARS AXIS RELEASE STRETCHING (STANDARD CHARACTER)**. HERZOG,GREG, DBA HERZOG BODY TECH, (U.S. CLS. 100, 101 AND 107). SN 85-197,396. PUB. 6-7-2011. FILED 12-14-2010.
- 4,015,286. **PILOT SCHOOL (STANDARD CHARACTER)**. THE PILOT SCHOOL, INC., MULTIPLE CLASS, (INT. CLS. 41 AND 44), (U.S. CLS. 100, 101 AND 107). SN 85-198,168. PUB. 6-7-2011. FILED 12-15-2010.
- 4,015,287. **UNLOCK THE POTENTIAL (STANDARD CHARACTER)**. THE PILOT SCHOOL, INC., MULTIPLE CLASS, (INT. CLS. 41 AND 44), (U.S. CLS. 100, 101 AND 107). SN 85-198,191. PUB. 6-7-2011. FILED 12-15-2010.
- 4,015,288. **UNLOCKING THE POTENTIAL (STANDARD CHARACTER)**. THE PILOT SCHOOL, INC., MULTIPLE CLASS, (INT. CLS. 41 AND 44), (U.S. CLS. 100, 101 AND 107). SN 85-198,223. PUB. 6-7-2011. FILED 12-15-2010.
- 4,015,293. **SCOTTSDALE CULINARY FESTIVAL AND DESIGN**. SCOTTSDALE LEAGUE FOR THE ARTS, (U.S. CLS. 100, 101 AND 107). SN 85-199,501. PUB. 6-7-2011. FILED 12-16-2010.
- 4,015,313. **PALACE ENTERTAINMENT AND DESIGN**. FESTIVAL FUN PARKS, LLC, (U.S. CLS. 100, 101 AND 107). SN 85-202,189. PUB. 6-7-2011. FILED 12-20-2010.
- 4,015,317. **ENERCISE (STANDARD CHARACTER)**. ENER-CISE GYM, LLC, (U.S. CLS. 100, 101 AND 107). SN 85-203,016. PUB. 6-7-2011. FILED 12-21-2010.
- 4,015,319. **BEDFORD STUYVESANT AND DESIGN**. BED-FORD STUYVESANT COLLEGIATE CHARTER SCHOOL, (U.S. CLS. 100, 101 AND 107). SN 85-203,283. PUB. 6-7-2011. FILED 12-21-2010.
- 4,015,320. **LEADERSHIP PREP AND DESIGN**. LEADERSHIP PREPARATORY BEDFORD STUYVESANT CHARTER SCHOOL, (U.S. CLS. 100, 101 AND 107). SN 85-203,305. PUB. 6-7-2011. FILED 12-21-2010.
- 4,015,321. **EXCELLENCE BOYS AND DESIGN**. EXCELLENCE BOYS CHARTER SCHOOL, (U.S. CLS. 100, 101 AND 107). SN 85-203,322. PUB. 6-7-2011. FILED 12-21-2010.
- 4,015,322. **ROCHESTER PREP AND DESIGN**. TRUE NORTH ROCHESTER PREPARATORY CHARTER SCHOOL, (U.S. CLS. 100, 101 AND 107). SN 85-203,348. PUB. 6-7-2011. FILED 12-21-2010.
- 4,015,328 (*See Class 35 for this trademark*).
- 4,015,330. **SURVIVOR REDEMPTION ISLAND OUTWIT OUTPLAY OUTLAST AND DESIGN**. SURVIVOR PRODUCTIONS LLC, (U.S. CLS. 100, 101 AND 107). SN 85-204,165. PUB. 6-7-2011. FILED 12-22-2010.
- 4,015,334 (*See Class 35 for this trademark*).
- 4,015,335. **FEEL FREE TO PROSPER (STANDARD CHARACTER)**. JENETT, MARILYN, (U.S. CLS. 100, 101 AND 107). SN 85-205,367. PUB. 6-7-2011. FILED 12-23-2010.
- 4,015,345. **AAA-CLASSIC DANCERS (STANDARD CHARACTER)**. ADVANCED INTERNATIONAL MARKETING CORPORATION, DBA AAA-CLASSIC DANCERS, (U.S. CLS. 100, 101 AND 107). SN 85-206,671. PUB. 6-7-2011. FILED 12-28-2010.
- 4,015,354. **RX TIMES (STANDARD CHARACTER)**. PROVIDE SOURCE, LLC, (U.S. CLS. 100, 101 AND 107). SN 85-207,839. PUB. 6-7-2011. FILED 12-30-2010.
- 4,015,359. **ROCABELLAZ IT'S A GIRL THING AND DESIGN**. NEW HOLLYWOOD ENTERTAINMENT LLC, (U.S. CLS. 100, 101 AND 107). SN 85-208,603. PUB. 6-7-2011. FILED 12-31-2010.
- 4,015,363. **MILLENNIAL LIVING (STANDARD CHARACTER)**. MILLENNIAL LIVING INC., AKA MILLENNIAL-LIVING.COM, (U.S. CLS. 100, 101 AND 107). SN 85-209,166. PUB. 6-7-2011. FILED 1-3-2011.
- 4,015,365. **MISCELLANEOUS DESIGN**. INDEPENDENCE TELEVISION CO., INC., (U.S. CLS. 100, 101 AND 107). SN 85-209,212. PUB. 6-7-2011. FILED 1-3-2011.
- 4,015,368. **THE WORLD'S CHILDREN'S PRIZE (STANDARD CHARACTER)**. WORLD'S CHILDREN'S PRIZE FOUNDATION, (U.S. CLS. 100, 101 AND 107). SN 85-209,337. PUB. 6-7-2011. FILED 1-3-2011.
- 4,015,372. **MISCELLANEOUS DESIGN**. ANDROMEDA TRAINING INC., (U.S. CLS. 100, 101 AND 107). SN 85-209,826. PUB. 6-7-2011. FILED 1-4-2011.
- 4,015,381. **ERACISM AND DESIGN**. ERACE, (U.S. CLS. 100, 101 AND 107). SN 85-211,133. PUB. 6-7-2011. FILED 1-5-2011.
- 4,015,383. **FOOTHOLDE AND DESIGN**. FOOTHOLDE, (U.S. CLS. 100, 101 AND 107). SN 85-211,489. PUB. 6-7-2011. FILED 1-5-2011.
- 4,015,393. **REIKI PEACE NETWORK TEACHING PEACE THROUGH REIKI AND DESIGN**. KAHNE, ELLEN L., (U.S. CLS. 100, 101 AND 107). SN 85-212,502. PUB. 6-7-2011. FILED 1-7-2011.
- 4,015,396. **YOGA GONE WILD (STANDARD CHARACTER)**. BOWEN, MEGHAN M, (U.S. CLS. 100, 101 AND 107). SN 85-212,666. PUB. 6-7-2011. FILED 1-7-2011.
- 4,015,398. **IDOC UNIVERSITY (STANDARD CHARACTER)**. IDOC, LLC, (U.S. CLS. 100, 101 AND 107). SN 85-212,753. PUB. 6-7-2011. FILED 1-7-2011.
- 4,015,405. **FIREPHONE SALES MADE EASY AND DESIGN**. PROACTIVE TRAINING SOLUTIONS, INC., (U.S. CLS. 100, 101 AND 107). SN 85-213,564. PUB. 6-7-2011. FILED 1-9-2011.
- 4,015,427. **I LIFT THINGS UP AND PUT THEM DOWN (STANDARD CHARACTER)**. PFIP, LLC, (U.S. CLS. 100, 101 AND 107). SN 85-215,167. PUB. 6-7-2011. FILED 1-11-2011.
- 4,015,428. **ROYAL COMEDY TOUR (STANDARD CHARACTER)**. NORTH AMERICAN ENTERTAINMENT GROUP, (U.S. CLS. 100, 101 AND 107). SN 85-215,514. PUB. 6-7-2011. FILED 1-12-2011.
- 4,015,430. **FELD ENTERTAINMENT (STANDARD CHARACTER)**. FELD ENTERTAINMENT, INC., (U.S. CLS. 100, 101 AND 107). SN 85-215,639. PUB. 6-7-2011. FILED 1-12-2011.
- 4,015,446. **EPONA RIDGE AND DESIGN**. EPONA RIDGE, (U.S. CLS. 100, 101 AND 107). SN 85-216,815. PUB. 6-7-2011. FILED 1-13-2011.
- 4,015,459. **BE TRUE TO YOU COACHING AND DESIGN**. BE TRUE TO YOU COACHING LLC, (U.S. CLS. 100, 101 AND 107). SN 85-217,468. PUB. 6-7-2011. FILED 1-13-2011.
- 4,015,466. **ATIVITA (STANDARD CHARACTER)**. BOEHRINGER INGELHEIM INTERNATIONAL GMBH, MULTIPLE CLASS, (INT. CLS. 41 AND 42), (U.S. CLS. 100, 101 AND 107). SN 85-217,848. PUB. 6-7-2011. FILED 1-14-2011.
- 4,015,467 (*See Class 35 for this trademark*).
- 4,015,487. **UNLEASH YOUR INNER ARTIST! (STANDARD CHARACTER)**. GENKI MEDIA LLC, (U.S. CLS. 100, 101 AND 107). SN 85-218,809. PUB. 6-7-2011. FILED 1-16-2011.
- 4,015,489. **REGGIE GIBSON (STANDARD CHARACTER)**. GIBSON, REGINALD E., (U.S. CLS. 100, 101 AND 107). SN 85-218,885. PUB. 6-7-2011. FILED 1-17-2011.
- 4,015,490. **SIMPLICITY LEARNING CENTER (STANDARD CHARACTER)**. BRIANA T BENNITT, DBA SIMPLICITY LEARNING CENTER, (U.S. CLS. 100, 101 AND 107). SN 85-218,889. PUB. 6-7-2011. FILED 1-17-2011.
- 4,015,491. **STARTART SCIENTIFIC & THERAPEUTIC APPROACHES TO ASSISTED REPRODUCTIVE TECHNOLOGY (STANDARD CHARACTER)**. LETTERS & SCIENCES, LLC, (U.S. CLS. 100, 101 AND 107). SN 85-218,921. PUB. 6-7-2011. FILED 1-17-2011.
- 4,015,494. **THE BIG EVENT (STANDARD CHARACTER)**. INSURMARK, INC., (U.S. CLS. 100, 101 AND 107). SN 85-219,135. PUB. 6-7-2011. FILED 1-17-2011.
- 4,015,501 (*See Class 16 for this trademark*).
- 4,015,514. **GROWING PRO (STANDARD CHARACTER)**. FRIDAYPHOTOSCHOOL.COM INC., (U.S. CLS. 100, 101 AND 107). SN 85-219,701. PUB. 6-7-2011. FILED 1-18-2011.
- 4,015,529. **THE DEPLOYMENT DIARIES (STANDARD CHARACTER)**. VICTORY MEDIA, INC., (U.S. CLS. 100, 101 AND 107). SN 85-220,059. PUB. 6-7-2011. FILED 1-18-2011.
- 4,015,530. **ELLIE PHOTOGRAPHY (STANDARD CHARACTER)**. ELLIE PHOTOGRAPHY, INC, (U.S. CLS. 100, 101 AND 107). SN 85-220,193. PUB. 6-7-2011. FILED 1-18-2011.
- 4,015,531. **STRENGTH IN NUMBERS ENTERTAINMENT (STANDARD CHARACTER)**. CLOR, DAN, (U.S. CLS. 100, 101 AND 107). SN 85-220,214. PUB. 6-7-2011. FILED 1-18-2011.

- 4,015,536. **PICCOLO CHEF AND DESIGN**. PICCOLO CHEF, LLC, (U.S. CLS. 100, 101 AND 107). SN 85-220,589. PUB. 6-7-2011. FILED 1-19-2011.
- 4,015,540. **CLAIRVOYANT COACHING (STANDARD CHARACTER)**. ZMARK SOFTWARE DESIGN, (U.S. CLS. 100, 101 AND 107). SN 85-220,721. PUB. 6-7-2011. FILED 1-19-2011.
- 4,015,543. **OHIO MONSTER BUCKS (STANDARD CHARACTER)**. COLLINS, CHRIS, (U.S. CLS. 100, 101 AND 107). SN 85-220,781. PUB. 6-7-2011. FILED 1-19-2011.
- 4,015,546. **NGP AND DESIGN**. INTELLIGENT MUSIC ENTERTAINMENT, INC., (U.S. CLS. 100, 101 AND 107). SN 85-220,806. PUB. 6-7-2011. FILED 1-19-2011.
- 4,015,550. **CLIA (STANDARD CHARACTER)**. CRUISE LINES INTERNATIONAL ASSOCIATION, INC., (U.S. CLS. 100, 101 AND 107). SN 85-220,915. PUB. 6-7-2011. FILED 1-19-2011.
- 4,015,551. **STUDIO DOGS (STANDARD CHARACTER)**. LEWIS, HOLLY, (U.S. CLS. 100, 101 AND 107). SN 85-220,921. PUB. 6-7-2011. FILED 1-19-2011.
- 4,015,553. **CLIA CRUISE ACADEMY AND DESIGN**. CRUISE LINES INTERNATIONAL ASSOCIATION, INC., (U.S. CLS. 100, 101 AND 107). SN 85-220,952. PUB. 6-7-2011. FILED 1-19-2011.
- 4,015,566 (*See Class 16 for this trademark*).
- 4,015,571. **GOT CHAI? (STANDARD CHARACTER)**. KAPLAN, JONATHAN, (U.S. CLS. 100, 101 AND 107). SN 85-221,316. PUB. 6-7-2011. FILED 1-19-2011.
- 4,015,576. **HISTORICAL ABSTRACTS (STANDARD CHARACTER)**. EBSCO INDUSTRIES, INC., (U.S. CLS. 100, 101 AND 107). SN 85-221,416. PUB. 6-7-2011. FILED 1-19-2011.
- 4,015,581 (*See Class 36 for this trademark*).
- 4,015,582 (*See Class 36 for this trademark*).
- 4,015,587. **MATRICULATOR (STANDARD CHARACTER)**. GARCIA, SR., NICHOLAS, (U.S. CLS. 100, 101 AND 107). SN 85-221,710. PUB. 6-7-2011. FILED 1-20-2011.
- 4,015,591. **IRON DEMONS MC NEW JERSEY AND DESIGN**. IRON DEMONS MC, (U.S. CLS. 100, 101 AND 107). SN 85-221,824. PUB. 6-7-2011. FILED 1-20-2011.
- 4,015,593. **CONNECTING MINDS WORLDWIDE (STANDARD CHARACTER)**. GLOBAL MENTORS, LLC, (U.S. CLS. 100, 101 AND 107). SN 85-221,848. PUB. 6-7-2011. FILED 1-20-2011.
- 4,015,630. **FURDOGRUFFER FURDOGRUFFY (STANDARD CHARACTER)**. AZER, STEVEN B., (U.S. CLS. 100, 101 AND 107). SN 85-222,734. PUB. 6-7-2011. FILED 1-20-2011.
- 4,015,643 (*See Class 25 for this trademark*).
- 4,015,655 (*See Class 25 for this trademark*).
- 4,015,656 (*See Class 25 for this trademark*).
- 4,015,657. **COMFORT RX (STANDARD CHARACTER)**. FOMO PRODUCTS, INC., (U.S. CLS. 100, 101 AND 107). SN 85-224,536. PUB. 6-7-2011. FILED 1-24-2011.
- 4,015,664 (*See Class 9 for this trademark*).
- 4,015,665. **DOUBLE DIAMOND BASEBALL AND DESIGN**. MCCORMICK & MCCORMICK HOLDINGS LLC, DBA DOUBLE DIAMOND BASEBALL LEAGUE, (U.S. CLS. 100, 101 AND 107). SN 85-224,912. PUB. 6-7-2011. FILED 1-24-2011.
- 4,015,675 (*See Class 35 for this trademark*).
- 4,015,677. **RC THE RANCH AT ROCK CREEK AND DESIGN**. ROCKING J RANCH, LLC, MULTIPLE CLASS, (INT. CLS. 41, 43 AND 44), (U.S. CLS. 100, 101 AND 107). SN 85-225,426. PUB. 6-7-2011. FILED 1-25-2011.
- 4,015,683 (*See Class 9 for this trademark*).
- 4,015,702. **THINK CLEARLY, WRITE PRECISELY (STANDARD CHARACTER)**. SPILLMAN, SUSAN, (U.S. CLS. 100, 101 AND 107). SN 85-226,838. PUB. 6-7-2011. FILED 1-26-2011.
- 4,015,704. **DESTINY HAS A NEW HOME (STANDARD CHARACTER)**. PITTSBURGH PENGUINS LP, (U.S. CLS. 100, 101 AND 107). SN 85-226,979. PUB. 6-7-2011. FILED 1-26-2011.
- 4,015,710. **IT'S YOUR BIZ (STANDARD CHARACTER)**. SUSAN SAYS, INC., (U.S. CLS. 100, 101 AND 107). SN 85-227,164. PUB. 6-7-2011. FILED 1-26-2011.
- 4,015,724. **THE JOYFUL MULLIGAN (STANDARD CHARACTER)**. ANDERSON, CONSTANCE E., DBA THE JOYFUL MULLIGAN, (U.S. CLS. 100, 101 AND 107). SN 85-227,872. PUB. 6-7-2011. FILED 1-27-2011.
- 4,015,728. **THE ANTIDOTE TO AUTOTUNE (STANDARD CHARACTER)**. LLOYD'S GARAGE, LLC, (U.S. CLS. 100, 101 AND 107). SN 85-227,998. PUB. 6-7-2011. FILED 1-27-2011.
- 4,015,743. **SCISCRIBE (STANDARD CHARACTER)**. FITZGERALD, DEBORAH A., MULTIPLE CLASS, (INT. CLS. 41 AND 42), (U.S. CLS. 100, 101 AND 107). SN 85-228,521. PUB. 6-7-2011. FILED 1-28-2011.
- 4,015,755. **HONOLU'I MOUNTAIN OUTPOST AND DESIGN**. KAPOHOKINE ADVENTURES, LLC, (U.S. CLS. 100, 101 AND 107). SN 85-228,715. PUB. 6-7-2011. FILED 1-28-2011.
- 4,015,756. **LEARNINGCOUNTS.ORG (STANDARD CHARACTER)**. COUNCIL FOR ADULT AND EXPERIENTIAL LEARNING, (U.S. CLS. 100, 101 AND 107). SN 85-228,743. PUB. 6-7-2011. FILED 1-28-2011.
- 4,015,764. **LAUREL SPRINGS (STANDARD CHARACTER)**. NOBEL LEARNING COMMUNITIES, INC., (U.S. CLS. 100, 101 AND 107). SN 85-228,815. PUB. 6-7-2011. FILED 1-28-2011.
- 4,015,775. **TS TRUE STARS DANCE ACADEMY AND DESIGN**. ZENOBIA COX, AND TEAIR HAYES, (U.S. CLS. 100, 101 AND 107). SN 85-228,984. PUB. 6-7-2011. FILED 1-28-2011.
- 4,015,778. **CHAIRMAN OF GOLF (STANDARD CHARACTER)**. GOMEZ, MARIA, (U.S. CLS. 100, 101 AND 107). SN 85-229,009. PUB. 6-7-2011. FILED 1-28-2011.
- 4,015,783. **HAANDI (STANDARD CHARACTER)**. GUNTUR, RADHA, (U.S. CLS. 100, 101 AND 107). SN 85-229,061. PUB. 6-7-2011. FILED 1-28-2011.
- 4,015,819. **YOGABILITATION (STANDARD CHARACTER)**. FULTON, SAMANTHA, (U.S. CLS. 100, 101 AND 107). SN 85-229,552. PUB. 6-7-2011. FILED 1-29-2011.
- 4,015,820. **QUICKMOVIES AND DESIGN**. SHALOM LEVY-TAM, (U.S. CLS. 100, 101 AND 107). SN 85-229,562. PUB. 6-7-2011. FILED 1-30-2011.
- 4,015,830. **EVERY STUDENT A LEADER (STANDARD CHARACTER)**. EUCLID MIDDLE SCHOOL, (U.S. CLS. 100, 101 AND 107). SN 85-229,755. PUB. 6-7-2011. FILED 1-31-2011.
- 4,015,832. **LIVE YOUR PURPOSE. (STANDARD CHARACTER)**. CALIFORNIA BAPTIST UNIVERSITY, (U.S. CLS. 100, 101 AND 107). SN 85-229,842. PUB. 6-7-2011. FILED 1-31-2011.
- 4,015,836. **IT'S NOT ABOUT GETTING INTO SHAPE, IT'S ABOUT GETTING INTO LIFE! (STANDARD CHARACTER)**. ALASKAFIT, LLC, (U.S. CLS. 100, 101 AND 107). SN 85-229,866. PUB. 6-7-2011. FILED 1-31-2011.
- 4,015,848 (*See Class 35 for this trademark*).
- 4,015,853. **CCUSD (STANDARD CHARACTER)**. CAVE CREEK UNIFIED SCHOOL DISTRICT, (U.S. CLS. 100, 101 AND 107). SN 85-230,084. PUB. 6-7-2011. FILED 1-31-2011.
- 4,015,854. **MINDSBEE (STANDARD CHARACTER)**. VARSHNEY, ANURAG, (U.S. CLS. 100, 101 AND 107). SN 85-230,088. PUB. 6-7-2011. FILED 1-31-2011.
- 4,015,858. **LEKOOL (STANDARD CHARACTER)**. LEKOOL INC., (U.S. CLS. 100, 101 AND 107). SN 85-230,208. PUB. 6-7-2011. FILED 1-31-2011.
- 4,015,867. **POSH ABLE (STANDARD CHARACTER)**. ANYTHING IS POSH ABLE EVENTS, (U.S. CLS. 100, 101 AND 107). SN 85-230,377. PUB. 6-7-2011. FILED 1-31-2011.
- 4,015,869. **FRINGE TOAST MUSIC (STANDARD CHARACTER)**. BARGERSTOCK, ANDREW S., (U.S. CLS. 100, 101 AND 107). SN 85-230,421. PUB. 6-7-2011. FILED 1-31-2011.
- 4,015,881. **TICKET 360 TICKET TIC TIC AND DESIGN**. GALAN ENTERPRISE INC, (U.S. CLS. 100, 101 AND 107). SN 85-230,588. PUB. 6-7-2011. FILED 1-31-2011.
- 4,015,882 (*See Class 16 for this trademark*).
- 4,015,891. **VALUENGAGER (STANDARD CHARACTER)**. WAGNER, GREGORY, (U.S. CLS. 100, 101 AND 107). SN 85-230,677. PUB. 6-7-2011. FILED 1-31-2011.
- 4,015,902. **EPIC ENTERTAINMENT. MONUMENTAL VALUE. (STANDARD CHARACTER)**. HOME BOX OFFICE, INC., (U.S. CLS. 100, 101 AND 107). SN 85-230,892. PUB. 6-7-2011. FILED 2-1-2011.
- 4,015,906. **RETOUCHUP (STANDARD CHARACTER)**. HOLLYWOOD FOTOFIX, INC., (U.S. CLS. 100, 101 AND 107). SN 85-230,971. PUB. 6-7-2011. FILED 2-1-2011.
- 4,015,921. **SOY LATINO CUANDO...** (STANDARD CHARAC-

- TER).** AOL INC., (U.S. CLS. 100, 101 AND 107). SN 85-231,141. PUB. 6-7-2011. FILED 1-21-2011.
4,015,924 (*See Class 25 for this trademark*).
- 4,015,932. **THE FOODINISTA (STANDARD CHARACTER).** FOGARTY, HEATHER, (U.S. CLS. 100, 101 AND 107). SN 85-231,251. PUB. 6-7-2011. FILED 2-1-2011.
- 4,015,938. **SINNS OF ATTRACTION (STANDARD CHARACTER).** SINNS OF ATTRACTION, LLC, (U.S. CLS. 100, 101 AND 107). SN 85-231,402. PUB. 6-7-2011. FILED 2-1-2011.
- 4,015,941. **JIGHEADS AND DESIGN.** BLACK ICE OUTDOOR PRODUCTIONS, LLC, (U.S. CLS. 100, 101 AND 107). SN 85-231,481. PUB. 6-7-2011. FILED 2-1-2011.
- 4,015,949. **BLACK SWAN YOGA (STANDARD CHARACTER).** BLACK SWAN YOGA, LLC, (U.S. CLS. 100, 101 AND 107). SN 85-231,629. PUB. 6-7-2011. FILED 2-1-2011.
4,015,958 (*See Class 3 for this trademark*).
- 4,015,974. **TOUCHPOINT EDUCATION (STANDARD CHARACTER).** PROVA EDUCATION INC., (U.S. CLS. 100, 101 AND 107). SN 85-232,093. PUB. 6-7-2011. FILED 2-2-2011.
- 4,015,977. **ISPLASH! (STANDARD CHARACTER).** BIG FISH GAMES, INC., (U.S. CLS. 100, 101 AND 107). SN 85-232,130. PUB. 6-7-2011. FILED 2-2-2011.
- 4,015,986. **WE SEE YOU. (STANDARD CHARACTER).** BUENA VISTA UNIVERSITY, (U.S. CLS. 100, 101 AND 107). SN 85-232,399. PUB. 6-7-2011. FILED 2-2-2011.
- 4,015,988. **ONEINDIA (STANDARD CHARACTER).** GREYNIUM INFORMATION TECHNOLOGIES PVT. LTD., MULTIPLE CLASS, (INT. CLS. 41 AND 42), (U.S. CLS. 100, 101 AND 107). SN 85-232,404. PUB. 6-7-2011. FILED 2-2-2011.
- 4,015,989. **IOWA'S ACCESSIBLY SCALED, EYE-OPENING UNIVERSITY (STANDARD CHARACTER).** BUENA VISTA UNIVERSITY, (U.S. CLS. 100, 101 AND 107). SN 85-232,411. PUB. 6-7-2011. FILED 2-2-2011.
- 4,015,995. **POWER SANFORD (STANDARD CHARACTER).** SANFORD, (U.S. CLS. 100, 101 AND 107). SN 85-232,459. PUB. 6-7-2011. FILED 2-2-2011.
- 4,015,997. **CALIBERS (STANDARD CHARACTER).** CALIBERS NATIONAL SHOOTERS SPORTS CENTERS, LC, (U.S. CLS. 100, 101 AND 107). SN 85-232,503. PUB. 6-7-2011. FILED 2-2-2011.
- 4,015,999. **CALIBERS AND DESIGN.** CALIBERS NATIONAL SHOOTERS SPORTS CENTERS, LC, (U.S. CLS. 100, 101 AND 107). SN 85-232,522. PUB. 6-7-2011. FILED 2-2-2011.
4,016,001 (*See Class 36 for this trademark*).
- 4,016,008. **BIOGIST (STANDARD CHARACTER).** DRATH, TOM, W., (U.S. CLS. 100, 101 AND 107). SN 85-232,683. PUB. 6-7-2011. FILED 2-2-2011.
- 4,016,010. **THE THREE THIEVES (STANDARD CHARACTER).** REBEL WINE CO. LLC, (U.S. CLS. 100, 101 AND 107). SN 85-232,690. PUB. 6-7-2011. FILED 2-2-2011.
- 4,016,014. **NERD'S EYE VIEW (STANDARD CHARACTER).** MANDEL, PAMELA D., (U.S. CLS. 100, 101 AND 107). SN 85-232,744. PUB. 6-7-2011. FILED 2-2-2011.
- 4,016,018. **WITNESS TO BEAUTY (STANDARD CHARACTER).** KIRKPATRICK, CHAD, (U.S. CLS. 100, 101 AND 107). SN 85-232,790. PUB. 6-7-2011. FILED 2-2-2011.
- 4,016,022. **PROPHYSICS (STANDARD CHARACTER).** PROPHYSICS INNOVATIONS, INC., (U.S. CLS. 100, 101 AND 107). SN 85-232,924. PUB. 6-7-2011. FILED 2-3-2011.
- 4,016,029. **JUST A LITTLE DITTY... (STANDARD CHARACTER).** JUST A LITTLE DITTY, LLC, (U.S. CLS. 100, 101 AND 107). SN 85-233,182. PUB. 6-7-2011. FILED 2-3-2011.
- 4,016,033. **HAUNTED BY HEROES (STANDARD CHARACTER).** THE THRASHERS, LLC, (U.S. CLS. 100, 101 AND 107). SN 85-233,255. PUB. 6-7-2011. FILED 2-3-2011.
- 4,016,047. **SPARKING NEW FLAMES ONE KID AT A TIME (STANDARD CHARACTER).** THE HOUSE DEVELOPMENT CORPORATION, NFP, (U.S. CLS. 100, 101 AND 107). SN 85-233,584. PUB. 6-7-2011. FILED 2-3-2011.
4,016,053 (*See Class 16 for this trademark*).
- 4,016,054. **POTLUCK (STANDARD CHARACTER).** WAKEFERN FOOD CORP., (U.S. CLS. 100, 101 AND 107). SN 85-234,201. PUB. 6-7-2011. FILED 2-4-2011.
- 4,016,055. **POTLUCK AND DESIGN.** WAKEFERN FOOD CORP., (U.S. CLS. 100, 101 AND 107). SN 85-234,229. PUB. 6-7-2011. FILED 2-4-2011.
- 4,016,062. **INFECTION CONTROL TODAY (STANDARD CHARACTER).** VIRGO PUBLISHING, LLC, (U.S. CLS. 100, 101 AND 107). SN 85-236,794. PUB. 6-7-2011. FILED 2-8-2011.
- 4,016,068. **SMARTCOACH PLUS (STANDARD CHARACTER).** RODALE INC., (U.S. CLS. 100, 101 AND 107). SN 85-239,054. PUB. 6-7-2011. FILED 2-10-2011.
- 4,016,073. **OUTSMART DIABETES (STANDARD CHARACTER).** RODALE INC., MULTIPLE CLASS, (INT. CLS. 41 AND 44), (U.S. CLS. 100, 101 AND 107). SN 85-239,283. PUB. 6-7-2011. FILED 2-10-2011.
- 4,016,104. **IFRIENDS AND DESIGN.** WEBPOWER, INC., (U.S. CLS. 100, 101 AND 107). SN 85-254,295. PUB. 6-7-2011. FILED S.R. 3-1-2011; AM. P.R. 4-11-2011.
- 4,016,127. **GOLDSBY GAMING CENTER AND DESIGN.** THE CHICKASAW NATION, (U.S. CLS. 100, 101 AND 107). SN 85-280,385. PUB. 6-7-2011. FILED 3-29-2011.
- 4,016,128. **NEWCASTLE GAMING CENTER AND DESIGN.** THE CHICKASAW NATION, (U.S. CLS. 100, 101 AND 107). SN 85-281,129. PUB. 6-7-2011. FILED 3-30-2011.
4,016,130 (*See Class 38 for this trademark*).
- 4,016,131. **TEXOMA GAMING AND DESIGN.** THE CHICKASAW NATION, (U.S. CLS. 100, 101 AND 107). SN 85-281,667. PUB. 6-7-2011. FILED 3-30-2011.
- 4,016,133. **GO WEST AND DESIGN.** BOARD OF REGENTS OF THE UNIVERSITY SYSTEM OF GEORGIA, (U.S. CLS. 100, 101 AND 107). SN 85-286,313. PUB. 6-7-2011. FILED 4-5-2011.
4,016,134 (*See Class 9 for this trademark*).
- 4,016,139. **BOK. HOMA CASINO AND DESIGN.** MISSISSIPPI BAND OF CHOCTAW INDIANS, MULTIPLE CLASS, (INT. CLS. 41 AND 43), (U.S. CLS. 100, 101 AND 107). SN 85-303,481. PUB. 6-7-2011. FILED 4-25-2011.
- 4,016,140. **HO-CHUNK (STYLIZED).** HO-CHUNK NATION, (U.S. CLS. 100, 101 AND 107). SN 85-304,695. PUB. 6-7-2011. FILED 4-26-2011.
- 4,016,141. **HO-CHUNK GAMING AND DESIGN.** HO-CHUNK NATION, (U.S. CLS. 100, 101 AND 107). SN 85-304,739. PUB. 6-7-2011. FILED 4-26-2011.
- 4,016,143 (*See Class 16 for this trademark*).

CLASS 42—SCIENTIFIC AND COMPUTER SERVICES

- 4,014,198 (*See Class 9 for this trademark*).
- 4,014,217 (*See Class 35 for this trademark*).
- 4,014,250 (*See Class 9 for this trademark*).
- 4,014,264 (*See Class 37 for this trademark*).
- 4,014,267 (*See Class 35 for this trademark*).
- 4,014,283 (*See Class 40 for this trademark*).
- 4,014,284 (*See Class 9 for this trademark*).
- 4,014,290 (*See Class 9 for this trademark*).
- 4,014,292 (*See Class 1 for this trademark*).
- 4,014,303 (*See Class 35 for this trademark*).
- 4,014,310 (*See Class 35 for this trademark*).
- 4,014,316 (*See Class 9 for this trademark*).
- 4,014,317 (*See Class 9 for this trademark*).
- 4,014,320 (*See Class 1 for this trademark*).
- 4,014,333 (*See Class 11 for this trademark*).
- 4,014,353. **D.S.I.P.H.E.R. (STANDARD CHARACTER).** SDI HEALTH LLC, MULTIPLE CLASS, (INT. CLS. 42 AND 44), (U.S. CLS. 100 AND 101). SN 77-862,860. PUB. 6-7-2011. FILED 11-2-2009.
- 4,014,355. **UNIKEN AND DESIGN.** UNIKEN BUSINESS SOLUTIONS, INC., (U.S. CLS. 100 AND 101). SN 77-872,530. PUB. 6-7-2011. FILED 11-13-2009.
- 4,014,378 (*See Class 9 for this trademark*).
- 4,014,379 (*See Class 9 for this trademark*).
- 4,014,380 (*See Class 9 for this trademark*).
- 4,014,383 (*See Class 9 for this trademark*).
- 4,014,391 (*See Class 9 for this trademark*).
- 4,014,395 (*See Class 9 for this trademark*).
- 4,014,397 (*See Class 37 for this trademark*).
- 4,014,411 (*See Class 9 for this trademark*).
- 4,014,425 (*See Class 9 for this trademark*).
- 4,014,426 (*See Class 9 for this trademark*).
- 4,014,451. **FDT (STANDARD CHARACTER).** ENDRES-

- S+HAUSER PROCESS SOLUTIONS AG, (U.S. CLS. 100 AND 101). SN 79-052,907. PUB. 12-15-2009. FILED 3-5-2008.
- 4,014,452 (*See Class 6 for this trademark*).
- 4,014,459 (*See Class 35 for this trademark*).
- 4,014,465 (*See Class 9 for this trademark*).
- 4,014,476 (*See Class 3 for this trademark*).
- 4,014,478 (*See Class 3 for this trademark*).
- 4,014,485 (*See Class 6 for this trademark*).
- 4,014,486 (*See Class 4 for this trademark*).
- 4,014,487 (*See Class 35 for this trademark*).
- 4,014,489 (*See Class 16 for this trademark*).
- 4,014,491 (*See Class 35 for this trademark*).
- 4,014,494 (*See Class 9 for this trademark*).
- 4,014,503 (*See Class 9 for this trademark*).
- 4,014,506 (*See Class 1 for this trademark*).
- 4,014,507 (*See Class 9 for this trademark*).
- 4,014,509 (*See Class 9 for this trademark*).
- 4,014,515 (*See Class 9 for this trademark*).
- 4,014,521 (*See Class 9 for this trademark*).
- 4,014,528. **ROADABOUT (STANDARD CHARACTER)**. LUC DEPROST, (U.S. CLS. 100 AND 101). SN 79-085,580. PUB. 6-7-2011. FILED 6-14-2010.
- 4,014,530 (*See Class 9 for this trademark*).
- 4,014,560 (*See Class 35 for this trademark*).
- 4,014,561 (*See Class 35 for this trademark*).
- 4,014,570 (*See Class 35 for this trademark*).
- 4,014,571 (*See Class 35 for this trademark*).
- 4,014,588. **CANTINETTA ANTINORI (STANDARD CHARACTER)**. P. ANTINORI S.P.A., (U.S. CLS. 100 AND 101). SN 79-089,112. PUB. 6-7-2011. FILED 8-3-2010.
- 4,014,632 (*See Class 9 for this trademark*).
- 4,014,635 (*See Class 1 for this trademark*).
- 4,014,637. **HYDRANONE (STANDARD CHARACTER)**. DSM IP ASSETS B.V., (U.S. CLS. 100 AND 101). SN 79-092,863. PUB. 6-7-2011. FILED 7-21-2010.
- 4,014,664 (*See Class 9 for this trademark*).
- 4,014,666 (*See Class 9 for this trademark*).
- 4,014,668 (*See Class 9 for this trademark*).
- 4,014,709. **BMCARE AND DESIGN**. BIOSTIME,INC.(-GUANGZHOU), (U.S. CLS. 100 AND 101). SN 85-039,536. PUB. 3-1-2011. FILED 5-15-2010.
- 4,014,721 (*See Class 9 for this trademark*).
- 4,014,738. **THE HARTFORD'S ABSENCE ADVISOR (STANDARD CHARACTER)**. HARTFORD FIRE INSURANCE COMPANY, (U.S. CLS. 100 AND 101). SN 85-054,555. PUB. 6-7-2011. FILED 6-4-2010.
- 4,014,741. **KEYPOINT (STANDARD CHARACTER)**. KEY-GENE, N.V., (U.S. CLS. 100 AND 101). SN 85-055,903. PUB. 6-7-2011. FILED 6-7-2010.
- 4,014,752 (*See Class 35 for this trademark*).
- 4,014,759 (*See Class 2 for this trademark*).
- 4,014,774 (*See Class 35 for this trademark*).
- 4,014,779 (*See Class 35 for this trademark*).
- 4,014,791 (*See Class 5 for this trademark*).
- 4,014,792 (*See Class 5 for this trademark*).
- 4,014,795. **SIX PONY HITCH (STANDARD CHARACTER)**. SIX PONY HITCH, LLC, (U.S. CLS. 100 AND 101). SN 85-070,702. PUB. 6-7-2011. FILED 6-24-2010.
- 4,014,797. **6 PONY HITCH AND DESIGN**. SIX PONY HITCH, LLC, (U.S. CLS. 100 AND 101). SN 85-070,850. PUB. 6-7-2011. FILED 6-24-2010.
- 4,014,813. **GREEN COMMUNITY TECHNOLOGIES (STANDARD CHARACTER)**. YELLOW WOOD ASSOCIATES, INC., (U.S. CLS. 100 AND 101). SN 85-074,815. PUB. 6-7-2011. FILED 6-30-2010.
- 4,014,815. **LET US BE YOUR GUIDE (STANDARD CHARACTER)**. ROVI TECHNOLOGIES CORPORATION, (U.S. CLS. 100 AND 101). SN 85-074,858. PUB. 6-7-2011. FILED 6-30-2010.
- 4,014,848. **AES INTERIORS & ASSOCIATES, INC. AND DESIGN**. AES INTERIORS & ASSOCIATES INC, (U.S. CLS. 100 AND 101). SN 85-080,708. PUB. 6-7-2011. FILED 7-8-2010.
- 4,014,853. **STUDYBUDDYCAMPUS (STANDARD CHARACTER)**. STUDYBUDDYCAMPUS LLC, (U.S. CLS. 100 AND 101). SN 85-081,960. PUB. 6-7-2011. FILED 7-10-2010.
- 4,014,857 (*See Class 35 for this trademark*).
- 4,014,859. **GBSINTL (STANDARD CHARACTER)**. TALBOT, THOMAS, (U.S. CLS. 100 AND 101). SN 85-082,872. PUB. 6-7-2011. FILED 7-12-2010.
- 4,014,905. **SEO BOOST AND DESIGN**. ADVICE COMPANY, (U.S. CLS. 100 AND 101). SN 85-092,980. PUB. 6-7-2011. FILED 7-26-2010.
- 4,014,971. **DROP-ME-A-LINE.COM AND DESIGN**. MURPHY, JAMES V., (U.S. CLS. 100 AND 101). SN 85-108,013. PUB. 6-7-2011. FILED 8-16-2010.
- 4,014,980. **ICES (STANDARD CHARACTER)**. INGENIX, INC., (U.S. CLS. 100 AND 101). SN 85-112,675. PUB. 6-7-2011. FILED 8-20-2010.
- 4,014,993 (*See Class 35 for this trademark*).
- 4,015,002 (*See Class 35 for this trademark*).
- 4,015,005. **CONTROL FREAKS (STANDARD CHARACTER)**. UTAK LABORATORIES, INC., (U.S. CLS. 100 AND 101). SN 85-121,274. PUB. 6-7-2011. FILED 9-1-2010.
- 4,015,014. **PRA VALUE ADVANTAGE PROCESS (STANDARD CHARACTER)**. PLUNKETT RAYSICH ARCHITECTS, LLP, (U.S. CLS. 100 AND 101). SN 85-121,876. PUB. 6-7-2011. FILED 9-2-2010.
- 4,015,015. **PRA VALUE ADVANTAGE PROCESS AND DESIGN**. PLUNKETT RAYSICH ARCHITECTS, LLP, (U.S. CLS. 100 AND 101). SN 85-121,900. PUB. 6-7-2011. FILED 9-2-2010.
- 4,015,045 (*See Class 9 for this trademark*).
- 4,015,058. **DIGITAL NEXUS (STANDARD CHARACTER)**. DIGITAL NEXUS TECHNOLOGIES, INC., (U.S. CLS. 100 AND 101). SN 85-136,253. PUB. 6-7-2011. FILED 9-23-2010.
- 4,015,059. **DIGITAL NEXUS AND DESIGN**. DIGITAL NEXUS TECHNOLOGIES, INC., (U.S. CLS. 100 AND 101). SN 85-136,262. PUB. 6-7-2011. FILED 9-23-2010.
- 4,015,061. **EASY (STANDARD CHARACTER)**. SNAP-ON BUSINESS SOLUTIONS INC., (U.S. CLS. 100 AND 101). SN 85-137,323. PUB. 3-1-2011. FILED 9-24-2010.
- 4,015,072. **TSR CONSULTING (STANDARD CHARACTER)**. THEODORE S. RAPPAPORT, (U.S. CLS. 100 AND 101). SN 85-139,913. PUB. 6-7-2011. FILED 9-28-2010.
- 4,015,073. **MASSIVELY BROADBAND (STANDARD CHARACTER)**. THEODORE S. RAPPAPORT, (U.S. CLS. 100 AND 101). SN 85-139,925. PUB. 6-7-2011. FILED 9-28-2010.
- 4,015,075 (*See Class 35 for this trademark*).
- 4,015,086 (*See Class 37 for this trademark*).
- 4,015,096. **FORWARD. DEDICATED. GLOBAL. (STANDARD CHARACTER)**. FAULKNER DESIGN GROUP, INC., (U.S. CLS. 100 AND 101). SN 85-146,822. PUB. 6-7-2011. FILED 10-6-2010.
- 4,015,108 (*See Class 37 for this trademark*).
- 4,015,118. **MYENOLOGIST (STANDARD CHARACTER)**. MY ENOLOGIST, INC., (U.S. CLS. 100 AND 101). SN 85-153,781. PUB. 6-7-2011. FILED 10-15-2010.
- 4,015,141. **RISKONE BY RISK RESOURCES AND DESIGN**. CONCEPT CAPITAL ADVISORS, LLC, (U.S. CLS. 100 AND 101). SN 85-160,162. PUB. 6-7-2011. FILED 10-25-2010.
- 4,015,160. **SYNAPTYK (STANDARD CHARACTER)**. SYNAPTYK, INC., (U.S. CLS. 100 AND 101). SN 85-167,462. PUB. 6-7-2011. FILED 11-2-2010.
- 4,015,162. **NATURALLY THINKING (STANDARD CHARACTER)**. SYNAPTYK, INC., (U.S. CLS. 100 AND 101). SN 85-167,484. PUB. 6-7-2011. FILED 11-2-2010.
- 4,015,163. **SYNAPTYK AND DESIGN**. SYNAPTYK, INC., (U.S. CLS. 100 AND 101). SN 85-167,507. PUB. 6-7-2011. FILED 11-2-2010.
- 4,015,185 (*See Class 35 for this trademark*).
- 4,015,188 (*See Class 35 for this trademark*).
- 4,015,192 (*See Class 35 for this trademark*).
- 4,015,196 (*See Class 35 for this trademark*).
- 4,015,202 (*See Class 35 for this trademark*).
- 4,015,204 (*See Class 1 for this trademark*).
- 4,015,214. **CIMNET (STANDARD CHARACTER)**. CIMNET SYSTEMS, INC., (U.S. CLS. 100 AND 101). SN 85-182,116. PUB. 6-7-2011. FILED 11-22-2010.
- 4,015,219 (*See Class 35 for this trademark*).
- 4,015,233 (*See Class 35 for this trademark*).
- 4,015,273. **SYMPHONY (STANDARD CHARACTER)**. MORTGAGE CADENCE, LLC, (U.S. CLS. 100 AND 101). SN 85-196,414. PUB. 6-7-2011. FILED 12-13-2010.
- 4,015,278 (*See Class 9 for this trademark*).
- 4,015,280. **DATABANK SERVICES (STANDARD CHARACTER)**

- TER**. DATABANK DATA SERVICES, LLC, MULTIPLE CLASS. (INT. CLS. 42 AND 45), (U.S. CLS. 100 AND 101). SN 85-197,110. PUB. 6-7-2011. FILED 12-14-2010.
- 4,015,299 (*See Class 9 for this trademark*).
- 4,015,316. **PARK CITY GROUP TRUSTED BUSINESS SOLUTIONS AND DESIGN**. PARK CITY GROUP, INC., (U.S. CLS. 100 AND 101). SN 85-202,642. PUB. 6-7-2011. FILED 12-21-2010.
- 4,015,318. **NINJATO (STANDARD CHARACTER)**. SUPPORT-COM, INC., (U.S. CLS. 100 AND 101). SN 85-203,130. PUB. 6-7-2011. FILED 12-21-2010.
- 4,015,323. **HEALTH QUALITY2 (STYLIZED)**. LEGORRETA, ANTONIO, (U.S. CLS. 100 AND 101). SN 85-203,372. PUB. 6-7-2011. FILED 12-21-2010.
- 4,015,334 (*See Class 35 for this trademark*).
- 4,015,340. **XPOUS AND DESIGN**. XPOUS LLC, (U.S. CLS. 100 AND 101). SN 85-206,275. PUB. 6-7-2011. FILED 12-28-2010.
- 4,015,348. **TEST FACTORY ONSHORE QUALITY ASSURANCE (STYLIZED)**. RODOV, ALEX, (U.S. CLS. 100 AND 101). SN 85-207,404. PUB. 6-7-2011. FILED 12-29-2010.
- 4,015,357. **ETHERIOS AND DESIGN**. ETHERIOS, (U.S. CLS. 100 AND 101). SN 85-208,349. PUB. 6-7-2011. FILED 12-30-2010.
- 4,015,362. **SNOW FOX (STANDARD CHARACTER)**. INDEPENDENCE TELEVISION CO., INC., (U.S. CLS. 100 AND 101). SN 85-209,160. PUB. 6-7-2011. FILED 1-3-2011.
- 4,015,364. **MISCELLANEOUS DESIGN**. INDEPENDENCE TELEVISION CO., INC., (U.S. CLS. 100 AND 101). SN 85-209,202. PUB. 6-7-2011. FILED 1-3-2011.
- 4,015,366. **ON DEMAND TESTING (STANDARD CHARACTER)**. RODOV, ALEX, (U.S. CLS. 100 AND 101). SN 85-209,292. PUB. 6-7-2011. FILED 1-3-2011.
- 4,015,367 (*See Class 35 for this trademark*).
- 4,015,370. **MY VENUE SOURCE AND DESIGN**. MY VENUE SOURCE LLC., (U.S. CLS. 100 AND 101). SN 85-209,590. PUB. 6-7-2011. FILED 1-3-2011.
- 4,015,378. **CRATECH (STANDARD CHARACTER)**. CRATECH, INC., (U.S. CLS. 100 AND 101). SN 85-210,962. PUB. 6-7-2011. FILED 1-5-2011.
- 4,015,379 (*See Class 35 for this trademark*).
- 4,015,402. **FEARLESS 5 (STANDARD CHARACTER)**. FEARLESS SOLUTIONS, LLC, (U.S. CLS. 100 AND 101). SN 85-213,318. PUB. 6-7-2011. FILED 1-7-2011.
- 4,015,416 (*See Class 35 for this trademark*).
- 4,015,442. **INNOVENTIONS (STANDARD CHARACTER)**. INNOVENTIONS INC., (U.S. CLS. 100 AND 101). SN 85-216,411. PUB. 6-7-2011. FILED 1-12-2011.
- 4,015,444 (*See Class 37 for this trademark*).
- 4,015,454. **PREMIEHR (STANDARD CHARACTER)**. SHERIDAN HEALTHCARE, INC., (U.S. CLS. 100 AND 101). SN 85-217,116. PUB. 6-7-2011. FILED 1-13-2011.
- 4,015,461. **SERVICE-NOW.COM (STANDARD CHARACTER)**. SERVICE-NOW.COM, (U.S. CLS. 100 AND 101). SN 85-217,551. PUB. 6-7-2011. FILED 1-13-2011.
- 4,015,466 (*See Class 41 for this trademark*).
- 4,015,511 (*See Class 37 for this trademark*).
- 4,015,521. **PARENT TREND (STANDARD CHARACTER)**. KOPP, KENNETH, (U.S. CLS. 100 AND 101). SN 85-219,890. PUB. 6-7-2011. FILED 1-18-2011.
- 4,015,559. **MISCELLANEOUS DESIGN**. STEPHEN A. HALES, (U.S. CLS. 100 AND 101). SN 85-221,049. PUB. 6-7-2011. FILED 1-19-2011.
- 4,015,560. **PRAGMATIC AGILITY (STANDARD CHARACTER)**. PRAGMATICS, INC., (U.S. CLS. 100 AND 101). SN 85-221,057. PUB. 6-7-2011. FILED 1-19-2011.
- 4,015,568. **SHOOT PROOF (STYLIZED)**. BLENDED BITS, LLC, (U.S. CLS. 100 AND 101). SN 85-221,284. PUB. 6-7-2011. FILED 1-19-2011.
- 4,015,581 (*See Class 36 for this trademark*).
- 4,015,582 (*See Class 36 for this trademark*).
- 4,015,609. **K. SMITH DESIGN (STANDARD CHARACTER)**. LOFTON, KIMBERLY, (U.S. CLS. 100 AND 101). SN 85-222,158. PUB. 6-7-2011. FILED 1-20-2011.
- 4,015,610. **APPLY IN THE SKY (STANDARD CHARACTER)**. APPLY IN THE SKY, INC., (U.S. CLS. 100 AND 101). SN 85-222,246. PUB. 6-7-2011. FILED 1-20-2011.
- 4,015,627. **FAR REACH TECHNOLOGIES (STANDARD CHARACTER)**. FAR REACH TECHNOLOGIES, INCORPORATED, (U.S. CLS. 100 AND 101). SN 85-222,605. PUB. 6-7-2011. FILED 1-20-2011.
- 4,015,641. **MAKING BETTER HEALTHCARE POSSIBLE (STANDARD CHARACTER)**. SANTA ROSA CONSULTING, INC., (U.S. CLS. 100 AND 101). SN 85-223,135. PUB. 6-7-2011. FILED 1-21-2011.
- 4,015,670. **SUNSHINE SEARCH (STANDARD CHARACTER)**. ELLIS, DANNY, (U.S. CLS. 100 AND 101). SN 85-225,018. PUB. 6-7-2011. FILED 1-24-2011.
- 4,015,675 (*See Class 35 for this trademark*).
- 4,015,683 (*See Class 9 for this trademark*).
- 4,015,699. **IOBYTE (STANDARD CHARACTER)**. MARC DANIEL LUBART, DBA IOBYTE SOLUTIONS, INC., (U.S. CLS. 100 AND 101). SN 85-226,759. PUB. 6-7-2011. FILED 1-26-2011.
- 4,015,712. **STRAIGHT UP AND DESIGN**. SUS, LLC, (U.S. CLS. 100 AND 101). SN 85-227,171. PUB. 6-7-2011. FILED 1-26-2011.
- 4,015,716. **ICOMPLISHMENTS (STANDARD CHARACTER)**. TAPME, INC., (U.S. CLS. 100 AND 101). SN 85-227,517. PUB. 6-7-2011. FILED 1-27-2011.
- 4,015,743 (*See Class 41 for this trademark*).
- 4,015,747 (*See Class 35 for this trademark*).
- 4,015,750. **BIOSTELLA (STANDARD CHARACTER)**. VAI-NORIUS, ENRIKAS, (U.S. CLS. 100 AND 101). SN 85-228,677. PUB. 6-7-2011. FILED 1-28-2011.
- 4,015,761 (*See Class 38 for this trademark*).
- 4,015,763. **42BOOKS (STANDARD CHARACTER)**. KRUTHOFF, TROY, (U.S. CLS. 100 AND 101). SN 85-228,802. PUB. 6-7-2011. FILED 1-28-2011.
- 4,015,766. **ASK STUDIO (STANDARD CHARACTER)**. ARCHITECTS SCHIPPER KASTNER, P.C., DBA ASK STUDIO, (U.S. CLS. 100 AND 101). SN 85-228,852. PUB. 6-7-2011. FILED 1-28-2011.
- 4,015,813. **COMPEFFI (STANDARD CHARACTER)**. COMPEFFI LLC, (U.S. CLS. 100 AND 101). SN 85-229,506. PUB. 6-7-2011. FILED 1-29-2011.
- 4,015,826. **MEDICINES THAT MAKE A DIFFERENCE (STANDARD CHARACTER)**. THERAVANCE, INC., (U.S. CLS. 100 AND 101). SN 85-229,623. PUB. 6-7-2011. FILED 1-30-2011.
- 4,015,845 (*See Class 9 for this trademark*).
- 4,015,848 (*See Class 35 for this trademark*).
- 4,015,857. **CLINVUE AND DESIGN**. CLINVUE LLC, (U.S. CLS. 100 AND 101). SN 85-230,103. PUB. 6-7-2011. FILED 1-31-2011.
- 4,015,868. **WEBAZILLA (STANDARD CHARACTER)**. TM WEB PROPERTIES, LTD., (U.S. CLS. 100 AND 101). SN 85-230,410. PUB. 6-7-2011. FILED 1-31-2011.
- 4,015,878. **PRYMORYS (STANDARD CHARACTER)**. PRYMORYS ENVIRONMENTAL CONSULTING, INC., (U.S. CLS. 100 AND 101). SN 85-230,524. PUB. 6-7-2011. FILED 1-31-2011.
- 4,015,894. **DRCLOUDEHR (STANDARD CHARACTER)**. EN-SOFTEK, INC., (U.S. CLS. 100 AND 101). SN 85-230,712. PUB. 6-7-2011. FILED 1-31-2011.
- 4,015,913. **COMMERCE 8 HUB AND DESIGN**. COMMERCE TECHNOLOGIES, INC., (U.S. CLS. 100 AND 101). SN 85-231,036. PUB. 6-7-2011. FILED 2-1-2011.
- 4,015,919. **DROP-SHIP MASTER (STANDARD CHARACTER)**. COMMERCE TECHNOLOGIES, INC., (U.S. CLS. 100 AND 101). SN 85-231,075. PUB. 6-7-2011. FILED 2-1-2011.
- 4,015,962. **IT'S ALL ABOUT CONNECTIONS... (STANDARD CHARACTER)**. COLOCATION AMERICA CORPORATION, (U.S. CLS. 100 AND 101). SN 85-231,823. PUB. 6-7-2011. FILED 2-1-2011.
- 4,015,972. **ONE CONNECTION AND DESIGN**. COMMERCE TECHNOLOGIES, INC., (U.S. CLS. 100 AND 101). SN 85-232,057. PUB. 6-7-2011. FILED 2-2-2011.
- 4,015,988 (*See Class 41 for this trademark*).
- 4,016,016. **WFM NAVIGATOR (STANDARD CHARACTER)**. DON GIFFELS, (U.S. CLS. 100 AND 101). SN 85-232,765. PUB. 6-7-2011. FILED 2-2-2011.
- 4,016,025. **ONEMARKET (STANDARD CHARACTER)**. LOGICSOURCE, INC., (U.S. CLS. 100 AND 101). SN 85-233,049. PUB. 6-7-2011. FILED 2-3-2011.
- 4,016,032. **MISCELLANEOUS DESIGN**. GOLD SYSTEMS, INC., (U.S. CLS. 100 AND 101). SN 85-233,252. PUB. 6-7-2011. FILED 2-3-2011.

- 4,016,046. **BIOSELECT PEOPLE FRIENDLY. EARTH FRIENDLY. AND DESIGN.** BIOSELECT, INC., (U.S. CLS. 100 AND 101). SN 85-233,572. PUB. 6-7-2011. FILED 2-3-2011.
- 4,016,089. **SOCIAL EZE (STANDARD CHARACTER).** SUPER-MEDIA LLC, (U.S. CLS. 100 AND 101). SN 85-247,296. PUB. 6-7-2011. FILED 2-21-2011.

CLASS 43—HOTEL AND RESTAURANT SERVICES

- 4,014,257. **JOEY'S BBQ (STANDARD CHARACTER).** MAGGIORE, JOSEPH P, (U.S. CLS. 100 AND 101). SN 77-392,359. PUB. 6-7-2011. FILED 2-8-2008.
- 4,014,327 (*See Class 3 for this trademark*).
- 4,014,343. **SPARKLES! AND DESIGN.** SPARKLES! ENTERPRISES, LLC, (U.S. CLS. 100 AND 101). SN 77-847,356. PUB. 6-7-2011. FILED 10-13-2009.
- 4,014,357. **BEEF'S TO GO! AND DESIGN.** FSC FRANCHISE CO., LLC, (U.S. CLS. 100 AND 101). SN 77-880,527. PUB. 4-27-2010. FILED 11-25-2009.
- 4,014,438 (*See Class 30 for this trademark*).
- 4,014,442 (*See Class 30 for this trademark*).
- 4,014,480 (*See Class 35 for this trademark*).
- 4,014,492 (*See Class 29 for this trademark*).
- 4,014,503 (*See Class 9 for this trademark*).
- 4,014,570 (*See Class 35 for this trademark*).
- 4,014,571 (*See Class 35 for this trademark*).
- 4,014,587. **PAZTA PAZTA AND DESIGN.** ROBERT COSTELLO ARMSTRONG, (U.S. CLS. 100 AND 101). SN 79-089,102. PUB. 6-7-2011. FILED 9-13-2010.
- 4,014,690. **PINOCCHIOS PIZZA REAL PIZZA. REAL CHEESE. REAL FAST! AND DESIGN.** RESTAURANT INVESTMENTS, INC., (U.S. CLS. 100 AND 101). SN 85-030,442. PUB. 5-3-2011. FILED 5-5-2010.
- 4,014,744. **SUCKERS FOOD PRODUCTS LLC. AND DESIGN.** SUCKERS FOOD PRODUCTS, L.L.C., (U.S. CLS. 100 AND 101). SN 85-056,402. PUB. 6-7-2011. FILED 6-7-2010.
- 4,014,765. **4REAL MEALS.COM AND DESIGN.** SM TM LLC, (U.S. CLS. 100 AND 101). SN 85-064,185. PUB. 6-7-2011. FILED 6-16-2010.
- 4,014,802 (*See Class 41 for this trademark*).
- 4,014,811. **GREAT PLAINS BURGER COMPANY (STANDARD CHARACTER).** AAB COMPANY, LLC, DBA GREAT PLAINS BURGER COMPANY, (U.S. CLS. 100 AND 101). SN 85-074,218. PUB. 6-7-2011. FILED 6-29-2010.
- 4,014,959 (*See Class 30 for this trademark*).
- 4,015,039. **CANINE COZY CARE RESORT LLC AND DESIGN.** CANINE COZY CARE RESORT LLC, (U.S. CLS. 100 AND 101). SN 85-129,001. PUB. 6-7-2011. FILED 9-14-2010.
- 4,015,084. **PAL'S SUDDEN SERVICE AND DESIGN.** CRO-BAR, L.L.C., (U.S. CLS. 100 AND 101). SN 85-142,838. PUB. 6-7-2011. FILED 10-1-2010.
- 4,015,088. **PAL'S SUDDEN SERVICE (STANDARD CHARACTER).** CRO-BAR, L.L.C., (U.S. CLS. 100 AND 101). SN 85-143,207. PUB. 6-7-2011. FILED 10-1-2010.
- 4,015,102 (*See Class 39 for this trademark*).
- 4,015,137. **KIKI'S BISTRO PARIS CHICAGO C'EST PAS MAL! AND DESIGN.** LE BORDEAUX NORTH INC., (U.S. CLS. 100 AND 101). SN 85-158,813. PUB. 6-7-2011. FILED 10-22-2010.
- 4,015,148. **CANTINA TORTILLA GRILL AND DESIGN.** CANTINA GROUP, INC., (U.S. CLS. 100 AND 101). SN 85-162,703. PUB. 6-7-2011. FILED 10-27-2010.
- 4,015,203. **JOEY BAG A DONUTS (STANDARD CHARACTER).** JOEY BAG A DONUTS LLC, (U.S. CLS. 100 AND 101). SN 85-178,138. PUB. 6-7-2011. FILED 11-16-2010.
- 4,015,220. **CHARM CITY BURGER COMPANY (STANDARD CHARACTER).** E & M CHARM CORP., (U.S. CLS. 100 AND 101). SN 85-183,953. PUB. 6-7-2011. FILED 11-23-2010.
- 4,015,221. **CHARM CITY BURGER COMPANY AND DESIGN.** E & M CHARM CORP., (U.S. CLS. 100 AND 101). SN 85-183,957. PUB. 6-7-2011. FILED 11-23-2010.
- 4,015,231. **CHILD FOCUS, INC. MAKING THE DIFFERENCE AND DESIGN.** CHILD FOCUS, INC., MULTIPLE CLASS, (INT. CLS. 43 AND 44), (U.S. CLS. 100 AND 101). SN 85-186,293. PUB. 6-7-2011. FILED 11-29-2010.
- 4,015,244. **CHILLY DILLY'S AND DESIGN.** YORK PRETZEL COMPANY, (U.S. CLS. 100 AND 101). SN 85-188,979. PUB. 6-7-2011. FILED 12-2-2010.
- 4,015,271. **PEI WEI AND DESIGN.** PEI WEI ASIAN DINER, INC., (U.S. CLS. 100 AND 101). SN 85-196,269. PUB. 6-7-2011. FILED 12-13-2010.
- 4,015,336. **BOSTON BURGER COMPANY AND DESIGN.** CHARLES J. SILLARI, JR., (U.S. CLS. 100 AND 101). SN 85-205,534. PUB. 6-7-2011. FILED 12-24-2010.
- 4,015,338. **FOOTPRINTS DEVELOPMENT CENTER AND DESIGN.** CRYSTAL N. YEE, DBA FOOTPRINTS DEVELOPMENT CENTER, (U.S. CLS. 100 AND 101). SN 85-205,966. PUB. 6-7-2011. FILED 12-27-2010.
- 4,015,408. **HONEST COCKTAILS & MEATS (STANDARD CHARACTER).** TWISTED FARM, INC., (U.S. CLS. 100 AND 101). SN 85-214,020. PUB. 6-7-2011. FILED 1-10-2011.
- 4,015,436. **GRITTY MCDUFF'S (STANDARD CHARACTER).** BREW CORP., DBA GRITTY MCDUFF'S, (U.S. CLS. 100 AND 101). SN 85-216,022. PUB. 6-7-2011. FILED 1-12-2011.
- 4,015,464. **VITO & MICHAEL'S FAMOUS PIZZA ESTABLISHED 1979 THE ORIGINAL GOURMET PIZZA AND DESIGN.** KLEIN, MICHAEL, AND MAFFEI, VITO, (U.S. CLS. 100 AND 101). SN 85-217,760. PUB. 6-7-2011. FILED 1-14-2011.
- 4,015,520. **TORQUE CLUB AT RICHMOND INTERNATIONAL RACEWAY AND DESIGN.** RICHMOND INTERNATIONAL RACEWAY, INC., (U.S. CLS. 100 AND 101). SN 85-219,869. PUB. 6-7-2011. FILED 1-18-2011.
- 4,015,527. **THE SIGNATURE ROOM AT THE NINETY-FIFTH THE RESTAURANT CHICAGO LOOKS UP TO AND DESIGN.** INFUSION MANAGEMENT GROUP, INC., (U.S. CLS. 100 AND 101). SN 85-220,031. PUB. 6-7-2011. FILED 1-18-2011.
- 4,015,547 (*See Class 25 for this trademark*).
- 4,015,557. **98FORTY TAPAS & TEQUILA AND DESIGN.** ROSEN HOTELS AND RESORTS, INC., (U.S. CLS. 100 AND 101). SN 85-221,036. PUB. 6-7-2011. FILED 1-19-2011.
- 4,015,563. **LEGACY VOYAGES (STANDARD CHARACTER).** AYALA, HANA, (U.S. CLS. 100 AND 101). SN 85-221,147. PUB. 6-7-2011. FILED 1-19-2011.
- 4,015,619. **CAFÉ NUVÓ AND DESIGN.** VIDA Y ESTILO, CORP., (U.S. CLS. 100 AND 101). SN 85-222,422. PUB. 6-7-2011. FILED 1-20-2011.
- 4,015,642. **MISCELLANEOUS DESIGN.** GROUNDS FOR A BETTER WORLD, LLC, (U.S. CLS. 100 AND 101). SN 85-223,211. PUB. 6-7-2011. FILED 1-21-2011.
- 4,015,651. **MISSION: CATS (STANDARD CHARACTER).** CATS IN THE CITY, LLC, (U.S. CLS. 100 AND 101). SN 85-223,778. PUB. 6-7-2011. FILED 1-22-2011.
- 4,015,652. **MIMIZ DAYCARE (STANDARD CHARACTER).** MARYAM YOOSEFI, (U.S. CLS. 100 AND 101). SN 85-223,864. PUB. 6-7-2011. FILED 1-22-2011.
- 4,015,662. **TWISTED SUBS (STANDARD CHARACTER).** LEONHARDT, MICHAEL, (U.S. CLS. 100 AND 101). SN 85-224,789. PUB. 6-7-2011. FILED 1-24-2011.
- 4,015,677 (*See Class 41 for this trademark*).
- 4,015,689. **AMANFAYUN (STANDARD CHARACTER).** AMANRESORTS LIMITED, (U.S. CLS. 100 AND 101). SN 85-226,317. PUB. 6-7-2011. FILED 1-26-2011.
- 4,015,726. **TIMBERWOODS (STANDARD CHARACTER).** TIMBERWOODS VACATION VILLAS, (U.S. CLS. 100 AND 101). SN 85-227,936. PUB. 6-7-2011. FILED 1-27-2011.
- 4,015,780. **GET YO SWIRL ON (STANDARD CHARACTER).** CARROLL, CRYSTAL, (U.S. CLS. 100 AND 101). SN 85-229,019. PUB. 6-7-2011. FILED 1-28-2011.
- 4,015,784. **MYLIFE MYWAY MYFROYO (STANDARD CHARACTER).** CARROLL, CRYSTAL, (U.S. CLS. 100 AND 101). SN 85-229,068. PUB. 6-7-2011. FILED 1-28-2011.
- 4,015,789. **MISCELLANEOUS DESIGN.** CARROLL, CRYSTAL, (U.S. CLS. 100 AND 101). SN 85-229,128. PUB. 6-7-2011. FILED 1-28-2011.
- 4,015,852. **SAY HELLO TO FRESH (STANDARD CHARACTER).** SUNNYSIDE GROUP LLC, (U.S. CLS. 100 AND 101). SN 85-230,059. PUB. 6-7-2011. FILED 1-31-2011.
- 4,015,859. **ALFREDHOUSE (STANDARD CHARACTER).** ALFREDHOUSE ELDERCARE, INC., (U.S. CLS. 100 AND 101). SN 85-230,226. PUB. 6-7-2011. FILED 1-31-2011.
- 4,015,983. **SAILPORT (STANDARD CHARACTER).** PROVI-

DENT MANAGEMENT CORPORATION, DBA SAILPORT WATERFRONT SUITES ON TAMPA BAY, (U.S. CLS. 100 AND 101). SN 85-232,364. PUB. 6-7-2011. FILED 2-2-2011.

4,015,985. **ABBOT'S PIZZA COMPANY (STANDARD CHARACTER)**. ABBOT'S PIZZA COMPANY LLC, (U.S. CLS. 100 AND 101). SN 85-232,389. PUB. 6-7-2011. FILED 2-2-2011.

4,015,993. **HOME OF THE BAGEL CRUST PIZZA (STANDARD CHARACTER)**. ABBOT'S PIZZA COMPANY LLC, (U.S. CLS. 100 AND 101). SN 85-232,443. PUB. 6-7-2011. FILED 2-2-2011.

4,015,998. **ABBOT'S PIZZA COMPANY APC HOME OF THE BAGEL CRUST PIZZA AND DESIGN**. ABBOT'S PIZZA COMPANY LLC, (U.S. CLS. 100 AND 101). SN 85-232,514. PUB. 6-7-2011. FILED 2-2-2011.

4,016,009. **THE FINAL SCORE (STANDARD CHARACTER)**. SPENCER STEPHENS, LLC, (U.S. CLS. 100 AND 101). SN 85-232,686. PUB. 6-7-2011. FILED 2-2-2011.

4,016,027. **MILKBOY (STANDARD CHARACTER)**. MILKBOY COFFEE, LLC, (U.S. CLS. 100 AND 101). SN 85-233,081. PUB. 6-7-2011. FILED 2-3-2011.

4,016,138. **THE INN AT TREASURE VALLEY AND DESIGN**. THE CHICKASAW NATION, (U.S. CLS. 100 AND 101). SN 85-291,861. PUB. 6-7-2011. FILED 4-11-2011.

4,016,139 (*See Class 41 for this trademark*).

CLASS 44—MEDICAL, BEAUTY AND AGRICULTURAL SERVICES

4,014,200 (*See Class 3 for this trademark*).

4,014,212. **YUVA (STANDARD CHARACTER)**. YUVA THREADING SALON, INC., (U.S. CLS. 100 AND 101). SN 76-703,298. PUB. 6-7-2011. FILED 6-8-2010.

4,014,246. **MOTHER NATURE'S SUNSCREEN (STANDARD CHARACTER)**. SHPUR, MAURICE, (U.S. CLS. 100 AND 101). SN 77-011,550. PUB. 6-7-2011. FILED 10-2-2006.

4,014,251. **THE ENLIGHTENED CHEF (STANDARD CHARACTER)**. CHICAGO RESEARCH CHEFS LLC, (U.S. CLS. 100 AND 101). SN 77-205,599. PUB. 6-7-2011. FILED 6-13-2007.

4,014,304. **ABILITY4LIFE (STANDARD CHARACTER)**. BERNS, MARVIN, (U.S. CLS. 100 AND 101). SN 77-725,792. PUB. 10-5-2010. FILED 4-30-2009.

4,014,310 (*See Class 35 for this trademark*).

4,014,313 (*See Class 16 for this trademark*).

4,014,327 (*See Class 3 for this trademark*).

4,014,336 (*See Class 9 for this trademark*).

4,014,337 (*See Class 6 for this trademark*).

4,014,353 (*See Class 42 for this trademark*).

4,014,365. **CRYOGENIC LABORATORIES (STYLIZED)**. GENETICS & IVF INSTITUTE, (U.S. CLS. 100 AND 101). SN 77-890,443. PUB. 6-7-2011. FILED 12-10-2009.

4,014,386 (*See Class 39 for this trademark*).

4,014,398. **SCOLIOSIS SOS (STANDARD CHARACTER)**. SCOLIOSIS SOS LIMITED, (U.S. CLS. 100 AND 101). SN 77-922,302. PUB. 12-7-2010. FILED 1-28-2010.

4,014,403 (*See Class 16 for this trademark*).

4,014,430 (*See Class 16 for this trademark*).

4,014,489 (*See Class 16 for this trademark*).

4,014,507 (*See Class 9 for this trademark*).

4,014,509 (*See Class 9 for this trademark*).

4,014,510 (*See Class 9 for this trademark*).

4,014,639 (*See Class 11 for this trademark*).

4,014,672. **HEALTHDIRECT (STYLIZED)**. LIVING WELL HEALTH SOLUTIONS, LLC, (U.S. CLS. 100 AND 101). SN 85-009,590. PUB. 1-4-2011. FILED 4-8-2010.

4,014,693. **PHYHEALTH (STANDARD CHARACTER)**. PHY-HEALTH CORPORATION, (U.S. CLS. 100 AND 101). SN 85-033,447. PUB. 6-7-2011. FILED 5-7-2010.

4,014,798. **POINT WELL TAKEN (STANDARD CHARACTER)**. LAURA COLESON-SCHREUR, MULTIPLE CLASS, (INT. CLS. 44 AND 45), (U.S. CLS. 100 AND 101). SN 85-071,073. PUB. 6-7-2011. FILED 6-24-2010.

4,014,878. **KWIK STITCH AND DESIGN**. CABRERA, RAFAEL, DBA PLASTIC SURGERY SPECIALISTS OF BOCA RATON, (U.S. CLS. 100 AND 101). SN 85-087,263. PUB. 6-7-2011. FILED 7-19-2010.

4,014,920. **FARM JOURNAL LEGACY PROJECT (STYLIZED)**. FARM JOURNAL, INC., (U.S. CLS. 100 AND 101). SN 85-094,927. PUB. 6-7-2011. FILED 7-28-2010.

4,014,922 (*See Class 16 for this trademark*).

4,014,967. **ENT AND ALLERGY ASSOCIATES, LLP ENTANDALLERGY.COM AND DESIGN**. ENT AND ALLERGY ASSOCIATES, LLP, (U.S. CLS. 100 AND 101). SN 85-105,849. PUB. 6-7-2011. FILED 8-12-2010.

4,015,000. **ADVERTO VITUM TURN TOWARD LIFE (STANDARD CHARACTER)**. JEFFREY N. MAR, M.D., INC., (U.S. CLS. 100 AND 101). SN 85-120,628. PUB. 6-7-2011. FILED 9-1-2010.

4,015,003. **V V V V V AND DESIGN**. JEFFREY N. MAR, M.D., INC., (U.S. CLS. 100 AND 101). SN 85-120,984. PUB. 6-7-2011. FILED 9-1-2010.

4,015,012. **HOLISTIC VANITY (STANDARD CHARACTER)**. PURE + SIMPLE BEAUTY INCORPORATED, (U.S. CLS. 100 AND 101). SN 85-121,788. PUB. 6-7-2011. FILED 9-2-2010.

4,015,041. **ELEVATE YOUR HEALTH (STANDARD CHARACTER)**. KONE INC., (U.S. CLS. 100 AND 101). SN 85-129,427. PUB. 3-1-2011. FILED 9-14-2010.

4,015,048. **DCI EMPOWERING PATIENTS AND DESIGN**. DIALYSIS CLINIC, INC., AKA DCI, (U.S. CLS. 100 AND 101). SN 85-131,326. PUB. 6-7-2011. FILED 9-16-2010.

4,015,069. **CARE ALTERNATIVES HOSPICE FOR THE LIFE WE LIVE AND DESIGN**. CARE SOLUTIONS, LLC, (U.S. CLS. 100 AND 101). SN 85-139,052. PUB. 6-7-2011. FILED 9-27-2010.

4,015,093 (*See Class 41 for this trademark*).

4,015,138. **OAKWOOD ANIMAL HOSPITAL (STANDARD CHARACTER)**. OAKWOOD ANIMAL HOSPITAL PC, (U.S. CLS. 100 AND 101). SN 85-158,855. PUB. 6-7-2011. FILED 10-22-2010.

4,015,139 (*See Class 10 for this trademark*).

4,015,157. **CLARITY WAY FIND YOUR PATH TO RECOVERY. AND DESIGN**. CLARITY WAY, INC., (U.S. CLS. 100 AND 101). SN 85-166,424. PUB. 6-7-2011. FILED 11-1-2010.

4,015,183. **LANDSLIDE (STANDARD CHARACTER)**. THE CULTURAL LANDSCAPE FOUNDATION, (U.S. CLS. 100 AND 101). SN 85-172,796. PUB. 6-7-2011. FILED 11-9-2010.

4,015,188 (*See Class 35 for this trademark*).

4,015,192 (*See Class 35 for this trademark*).

4,015,197. **ADORN BEAUTY CENTER & SPA (STANDARD CHARACTER)**. SANDRA E BONGART, DBA ADORN BEAUTY CENTER & SPA, (U.S. CLS. 100 AND 101). SN 85-177,565. PUB. 6-7-2011. FILED 11-16-2010.

4,015,200. **CHILDREN'S HOSPITAL OF MICHIGAN DMC DETROIT MEDICAL CENTER AND DESIGN**. VHS CHILDREN'S HOSPITAL OF MICHIGAN, INC., (U.S. CLS. 100 AND 101). SN 85-177,797. PUB. 6-7-2011. FILED 11-16-2010.

4,015,201. **EMBRACED SHARE SUPPLIES. HELP HEAL. AND DESIGN**. EMBRACED ATLANTA, INC., (U.S. CLS. 100 AND 101). SN 85-177,918. PUB. 6-7-2011. FILED 11-16-2010.

4,015,229. **LASER TATTOO REMOVAL . LASER HAIR REMOVAL DR. TATTOFF AND DESIGN**. DR. TATTOFF, INC., (U.S. CLS. 100 AND 101). SN 85-185,739. PUB. 6-7-2011. FILED 11-28-2010.

4,015,231 (*See Class 43 for this trademark*).

4,015,237 (*See Class 37 for this trademark*).

4,015,238 (*See Class 37 for this trademark*).

4,015,242. **MISCELLANEOUS DESIGN**. NORTH BROWARD HOSPITAL DISTRICT, (U.S. CLS. 100 AND 101). SN 85-188,532. PUB. 6-7-2011. FILED 12-1-2010.

4,015,250. **C.I. LUXURY MEDSPA AND DESIGN**. CELLULAR INTELLIGENCE, LLC, (U.S. CLS. 100 AND 101). SN 85-192,183. PUB. 6-7-2011. FILED 12-7-2010.

4,015,252. **HIGHQ AND DESIGN**. AGVENTURE. L.L.C., DBA WILLARD, (U.S. CLS. 100 AND 101). SN 85-192,438. PUB. 6-7-2011. FILED 12-7-2010.

4,015,256. **OJW (STANDARD CHARACTER)**. TEDDY ROTHSTEIN, DBA DR. TED ROTHSTEIN DDS PHD, (U.S. CLS. 100 AND 101). SN 85-192,818. PUB. 6-7-2011. FILED 12-8-2010.

4,015,283. **SURVIVING STRAIGHT INC (STANDARD CHARACTER)**. FLANNERY, CHRISTINE, (U.S. CLS. 100 AND 101). SN 85-197,438. PUB. 6-7-2011. FILED 12-14-2010.

4,015,286 (*See Class 41 for this trademark*).

4,015,287 (*See Class 41 for this trademark*).

4,015,288 (*See Class 41 for this trademark*).
 4,015,352. **BLUE BUTTON (STANDARD CHARACTER)**. DEPARTMENT OF VETERANS AFFAIRS, (U.S. CLS. 100 AND 101). SN 85-207,607. PUB. 5-3-2011. FILED 12-29-2010.
 4,015,369. **PEAK PERFORMANCE PHYSICAL THERAPY . SPORTS MEDICINE AND DESIGN**. PEAK PERFORMANCE REHABILITATION LLC, (U.S. CLS. 100 AND 101). SN 85-209,436. PUB. 6-7-2011. FILED 1-3-2011.
 4,015,374. **DENTAL WONDERLAND (STANDARD CHARACTER)**. SANDRA DEIRMENJIAN DDS, INC., DBA DENTAL WONDERLAND, (U.S. CLS. 100 AND 101). SN 85-209,989. PUB. 6-7-2011. FILED 1-4-2011.
 4,015,385. **CLIPS BARBER SHOP (STANDARD CHARACTER)**. SALAS, JOEL, (U.S. CLS. 100 AND 101). SN 85-211,537. PUB. 6-7-2011. FILED 1-6-2011.
 4,015,417. **NIRVANA (STANDARD CHARACTER)**. NIRVANA HEALTH SERVICES, INC., (U.S. CLS. 100 AND 101). SN 85-214,615. PUB. 6-7-2011. FILED 1-11-2011.
 4,015,422. **PET HAVEN (STANDARD CHARACTER)**. NORTHSTAR MEMORIAL GROUP LLC, MULTIPLE CLASS, (INT. CLS. 44 AND 45), (U.S. CLS. 100 AND 101). SN 85-214,731. PUB. 6-7-2011. FILED 1-11-2011.
 4,015,453. **E4 (STANDARD CHARACTER)**. STRATEGIC HEALTHCARE GROUP, LLC, (U.S. CLS. 100 AND 101). SN 85-217,100. PUB. 6-7-2011. FILED 1-13-2011.
 4,015,455. **MISCELLANEOUS DESIGN**. CHARLES FRANK CANGEMI, JR., (U.S. CLS. 100 AND 101). SN 85-217,136. PUB. 6-7-2011. FILED 1-13-2011.
 4,015,507. **COLLEAGUES IN CARE GLOBAL HEALTH NETWORK AND DESIGN**. OVERSEAS MEDICAL FUND, INC., (U.S. CLS. 100 AND 101). SN 85-219,512. PUB. 6-7-2011. FILED 1-18-2011.
 4,015,575. **TUPPER FIT AND DESIGN**. DART INDUSTRIES INC., (U.S. CLS. 100 AND 101). SN 85-221,406. PUB. 6-7-2011. FILED 1-19-2011.
 4,015,583. **ATLANTA DOG RUNNER AND DESIGN**. ATLANTA DOG RUNNER, (U.S. CLS. 100 AND 101). SN 85-221,658. PUB. 6-7-2011. FILED 1-19-2011.
 4,015,597. **MY WELLNESS SUMMIT (STANDARD CHARACTER)**. MY WELLNESS SUMMIT, INC., (U.S. CLS. 100 AND 101). SN 85-221,884. PUB. 6-7-2011. FILED 1-20-2011.
 4,015,612. **A WISER MIND (STANDARD CHARACTER)**. DRS HEALTH GROUP LLC, (U.S. CLS. 100 AND 101). SN 85-222,294. PUB. 6-7-2011. FILED 1-20-2011.
 4,015,617. **MISCELLANEOUS DESIGN**. DRS HEALTH GROUP LLC, (U.S. CLS. 100 AND 101). SN 85-222,357. PUB. 6-7-2011. FILED 1-20-2011.
 4,015,629. **ANGELS ON EARTH HOME HEALTH, INC. CARING WITH AN ANGELIC TOUCH AND DESIGN**. ANGELS ON EARTH HOME HEALTH, INC., (U.S. CLS. 100 AND 101). SN 85-222,688. PUB. 6-7-2011. FILED 1-20-2011.
 4,015,677 (*See Class 41 for this trademark*).
 4,015,737. **MISCELLANEOUS DESIGN**. RONDEROS NEUROSURGERY CENTER, LLC, (U.S. CLS. 100 AND 101). SN 85-228,489. PUB. 6-7-2011. FILED 1-28-2011.
 4,015,739. **WE TRANSFORM YOUR SMILE. YOU TRANSFORM YOUR LIFE. (STANDARD CHARACTER)**. TABIBZADEH, RAMIN, (U.S. CLS. 100 AND 101). SN 85-228,496. PUB. 6-7-2011. FILED 1-28-2011.
 4,015,744. **HARTNEY GREYMONT AND DESIGN**. THE DAVEY TREE EXPERT COMPANY, (U.S. CLS. 100 AND 101). SN 85-228,534. PUB. 6-7-2011. FILED 1-28-2011.
 4,015,790 (*See Class 5 for this trademark*).
 4,015,849. **THE DIFFERENCE BETWEEN HEALTHCARE AND TRUE CARE (STANDARD CHARACTER)**. ERIE COUNTY MEDICAL CENTER CORPORATION, (U.S. CLS. 100 AND 101). SN 85-230,020. PUB. 6-7-2011. FILED 1-31-2011.
 4,015,863. **BODYWIZ (STANDARD CHARACTER)**. TARDALSSON, JOAKIM BO, (U.S. CLS. 100 AND 101). SN 85-230,299. PUB. 6-7-2011. FILED 1-31-2011.
 4,015,872. **MISCELLANEOUS DESIGN**. CLEMSON SPORTS MEDICINE AND REHABILITATION, (U.S. CLS. 100 AND 101). SN 85-230,465. PUB. 6-7-2011. FILED 1-31-2011.
 4,015,915. **WE GIVE A SPIT! (STANDARD CHARACTER)**. ROWE & ASSOCIATES DENTAL CARE, PLLC, (U.S. CLS. 100 AND 101). SN 85-231,042. PUB. 6-7-2011. FILED 2-1-2011.

4,015,937. **CHOICE 1 (STANDARD CHARACTER)**. CLEARCHOICE HOLDINGS LLC, (U.S. CLS. 100 AND 101). SN 85-231,345. PUB. 6-7-2011. FILED 2-1-2011.
 4,015,976. **WHEN YOU'RE READY FOR BABY . . . SANFORD WOMEN'S IS READY FOR YOU (STANDARD CHARACTER)**. SANFORD, (U.S. CLS. 100 AND 101). SN 85-232,110. PUB. 6-7-2011. FILED 2-2-2011.
 4,015,984. **THIS IS WHAT YOU DO (STANDARD CHARACTER)**. SANFORD, (U.S. CLS. 100 AND 101). SN 85-232,368. PUB. 6-7-2011. FILED 2-2-2011.
 4,016,073 (*See Class 41 for this trademark*).
 4,016,124. **BRIGHT VISTA LAKEWOOD RANCH MEDICAL CENTER AND DESIGN**. UHS OF DELAWARE, INC., (U.S. CLS. 100 AND 101). SN 85-269,230. PUB. 6-7-2011. FILED 3-17-2011.

CLASS 45—PERSONAL AND LEGAL SERVICES

4,014,248. **CHOICEID (STANDARD CHARACTER)**. SECURTEST, INC., (U.S. CLS. 100 AND 101). SN 77-075,604. PUB. 6-7-2011. FILED 1-3-2007.
 4,014,287. **AUTHENTICOL (STANDARD CHARACTER)**. LYON, DENNIS BOWER, (U.S. CLS. 100 AND 101). SN 77-654,662. PUB. 6-7-2011. FILED 1-22-2009.
 4,014,303 (*See Class 35 for this trademark*).
 4,014,309. **THE ESSENTIAL FEMININE (STANDARD CHARACTER)**. SIMON, MAUREEN J., (U.S. CLS. 100 AND 101). SN 77-741,592. PUB. 6-7-2011. FILED 5-20-2009.
 4,014,395 (*See Class 9 for this trademark*).
 4,014,396 (*See Class 35 for this trademark*).
 4,014,411 (*See Class 9 for this trademark*).
 4,014,413 (*See Class 36 for this trademark*).
 4,014,414 (*See Class 36 for this trademark*).
 4,014,417 (*See Class 36 for this trademark*).
 4,014,418 (*See Class 36 for this trademark*).
 4,014,503 (*See Class 9 for this trademark*).
 4,014,530 (*See Class 9 for this trademark*).
 4,014,628 (*See Class 9 for this trademark*).
 4,014,694 (*See Class 35 for this trademark*).
 4,014,723. **OUR LADY OF FRECHOU (STANDARD CHARACTER)**. FRATERNITE NOTRE DAME, INC., (U.S. CLS. 100 AND 101). SN 85-049,342. PUB. 6-7-2011. FILED 5-27-2010.
 4,014,763 (*See Class 20 for this trademark*).
 4,014,783. **TULLY RINCKEY PLLC YOUR LAWYERS FOR LIFE (STANDARD CHARACTER)**. TULLY RINCKEY P.L.L.C., (U.S. CLS. 100 AND 101). SN 85-067,339. PUB. 6-7-2011. FILED 6-21-2010.
 4,014,788 (*See Class 9 for this trademark*).
 4,014,798 (*See Class 44 for this trademark*).
 4,014,993 (*See Class 35 for this trademark*).
 4,015,097. **. SHORE PARANORMAL . RESEARCH SOCIETY EVIDENCE INTEGRITY TRUST AND DESIGN**. ANSBACH SR., JAMES, (U.S. CLS. 100 AND 101). SN 85-146,848. PUB. 6-7-2011. FILED 10-6-2010.
 4,015,142. **ERS EXECUTIVE REPORTING SERVICE AND DESIGN**. EMERY & ASSOCIATES OF ST. PETERSBURG, INC., (U.S. CLS. 100 AND 101). SN 85-160,608. PUB. 6-7-2011. FILED 10-25-2010.
 4,015,191. **GLOZAL (STANDARD CHARACTER)**. GLOZAL, INC., FORMERLY REALTORBOOK, INC., (U.S. CLS. 100 AND 101). SN 85-175,573. PUB. 6-7-2011. FILED 11-12-2010.
 4,015,213 (*See Class 35 for this trademark*).
 4,015,222. **PROGUARD BY UNIVERSAL PROTECTION SERVICE AND DESIGN**. UNIVERSAL PROTECTION SERVICE, LP, (U.S. CLS. 100 AND 101). SN 85-184,078. PUB. 6-7-2011. FILED 11-23-2010.
 4,015,225. **C AND DESIGN**. CENTURY OAKS TITLE, LLC, (U.S. CLS. 100 AND 101). SN 85-184,787. PUB. 6-7-2011. FILED 11-24-2010.
 4,015,274. **EMPTY HOURGLASS AND DESIGN**. WAGONHEIM & ASSOCIATES, LLC, DBA THE WAGONHEIM LAW FIRM, (U.S. CLS. 100 AND 101). SN 85-196,509. PUB. 6-7-2011. FILED 12-13-2010.
 4,015,280 (*See Class 42 for this trademark*).

- 4,015,410. **D TECTION INCORPORATED AND DESIGN.** DTECTION INCORPORATED, (U.S. CLS. 100 AND 101). SN 85-214,129. PUB. 6-7-2011. FILED 1-10-2011.
- 4,015,422 (*See Class 44 for this trademark.*).
- 4,015,482. **GJ GOTJESUS? MINISTRIES AND DESIGN.** WIGHT, MARGARET LORRAINE, (U.S. CLS. 100 AND 101). SN 85-218,624. PUB. 6-7-2011. FILED 1-15-2011.
- 4,015,513. **WHISTLEBLOWERS AGAINST FRAUD AND DESIGN.** WHISTLEBLOWERS AGAINST FRAUD, LLC, (U.S. CLS. 100 AND 101). SN 85-219,681. PUB. 6-7-2011. FILED 1-18-2011.
- 4,015,592. **CREEKSIDE C H U R C H AND DESIGN.** CREEK-SIDE BIBLE CHURCH OF MONTGOMERY COUNTY, TEXAS, (U.S. CLS. 100 AND 101). SN 85-221,846. PUB. 6-7-2011. FILED 1-20-2011.
- 4,015,622. **HUMAN BEINGS BEING HUMAN (STANDARD CHARACTER).** HUMANITY WITHOUT BORDERS FOUNDATION INC., (U.S. CLS. 100 AND 101). SN 85-222,495. PUB. 6-7-2011. FILED 1-20-2011.
- 4,015,632. **NAMEPAGE (STANDARD CHARACTER).** CHADI GHAIH, (U.S. CLS. 100 AND 101). SN 85-222,781. PUB. 6-7-2011. FILED 1-21-2011.
- 4,015,639. **DEER CREEK CORPORATE SERVICES (STANDARD CHARACTER).** DEER CREEK CORPORATE SERVICES, INC., (U.S. CLS. 100 AND 101). SN 85-223,084. PUB. 6-7-2011. FILED 1-21-2011.
- 4,015,706. **NATURE'S INSPIRATION (STANDARD CHARACTER).** BETTER WORLD ENTERPRISES, INC., DBA YOUR TRUE NATURE, INC., (U.S. CLS. 100 AND 101). SN 85-227,072. PUB. 6-7-2011. FILED 1-26-2011.
- 4,015,779. **TRUST, PERSONAL ATTENTION AND RESULTS (STANDARD CHARACTER).** LAMB & BARNOSKY, LLP, (U.S. CLS. 100 AND 101). SN 85-229,015. PUB. 6-7-2011. FILED 1-28-2011.
- 4,015,782. **THE SCIENCE OF HUMAN HARMONY (STANDARD CHARACTER).** SACRED ESSENCE ENTERPRISES LLC, (U.S. CLS. 100 AND 101). SN 85-229,055. PUB. 6-7-2011. FILED 1-28-2011.
- 4,015,798. **ARC (STANDARD CHARACTER).** ARC IP LAW, PC, (U.S. CLS. 100 AND 101). SN 85-229,285. PUB. 6-7-2011. FILED 1-28-2011.
- 4,015,800. **ARCCELERATE (STANDARD CHARACTER).** ARC IP LAW, PC, (U.S. CLS. 100 AND 101). SN 85-229,319. PUB. 6-7-2011. FILED 1-28-2011.
- 4,015,825. **IDENTITY EASE (STANDARD CHARACTER).** CONSUMER BENEFIT SERVICES, INC., DBA CBSI, (U.S. CLS. 100 AND 101). SN 85-229,622. PUB. 6-7-2011. FILED 1-30-2011.
- 4,015,829. **WHERE CONFLICT FINDS RESOLUTION (STANDARD CHARACTER).** LAW OFFICE OF AIMEE L. EZZELL, PLLC, DBA CONREZ GROUP, (U.S. CLS. 100 AND 101). SN 85-229,733. PUB. 6-7-2011. FILED 1-31-2011.
- 4,015,835. **A WINDOW OF OPPORTUNITY (STANDARD CHARACTER).** RESTORATION COMMUNITY SERVICES, INC., (U.S. CLS. 100 AND 101). SN 85-229,853. PUB. 6-7-2011. FILED 1-31-2011.
- 4,015,879. **PRYMORYS (STANDARD CHARACTER).** PRYMORYS ENVIRONMENTAL CONSULTING, INC., (U.S. CLS. 100 AND 101). SN 85-230,549. PUB. 6-7-2011. FILED 1-31-2011.
- 4,015,890. **ST JOHN CHURCH TRANSFORMATION MINISTRIES INTERNATIONAL TRANSFORMING LIVES - RESTORING COMMUNITIES AND DESIGN.** ST. JOHN CHURCH TRANSFORMATION MINISTRIES INTERNATIONAL, DBA ST. JOHN BAPTIST CHURCH, (U.S. CLS. 100 AND 101). SN 85-230,665. PUB. 6-7-2011. FILED 1-31-2011.
- 4,015,954. **MINDFLO (STANDARD CHARACTER).** MINDFLO LLC, (U.S. CLS. 100 AND 101). SN 85-231,707. PUB. 6-7-2011. FILED 2-1-2011.
- 4,015,965. **BIG FIRM EXPERIENCE...SMALL FIRM SERVICE (STANDARD CHARACTER).** MELVIN N.A. AVANZADO, DBA THE AVANZADO LAW FIRM, (U.S. CLS. 100 AND 101). SN 85-231,879. PUB. 6-7-2011. FILED 2-1-2011.
- 4,016,000 (*See Class 38 for this trademark.*).
- 4,016,006. **WOOF! PET SITTING SERVICE (STANDARD CHARACTER).** MORRISON, KRISTIN LYNN, (U.S. CLS. 100 AND 101). SN 85-232,663. PUB. 6-7-2011. FILED 2-2-2011.
- 4,016,024. **THE POLITICS OF STYLE (STANDARD CHARACTER).** STEPHANY & COMPANY, LLC, (U.S. CLS. 100 AND 101). SN 85-233,029. PUB. 6-7-2011. FILED 2-3-2011.
- 4,016,130 (*See Class 38 for this trademark.*).

* * * * *

SECTION 2.—PRIOR UNITED STATES CLASSIFICATION

COLLECTIVE MEMBERSHIP MARKS

CLASS 200—COLLECTIVE MEMBERSHIP

4,015,397. **MARO BOYZ MUSCLE CAR CLUB (STANDARD CHARACTER)**. WILLIAMS, JERMAINE THOMAS, DBA MARO BOYZ MUSCLE CAR CLUB, SN 85-212,672. PUB. 6-7-2011. FILED 1-7-2011.

CERTIFICATION MARKS

CLASS A—GOODS

4,014,755. **AMERICAN HUMANE CERTIFIED AND DESIGN**. AMERICAN HUMANE ASSOCIATION, SN 85-060,956. PUB. 6-7-2011. FILED 6-11-2010.

* * * * *

TRADEMARK REGISTRATIONS ISSUED UNDER SECTION 1(d)

The following marks have registered on the Principal Register pursuant to the intent-to-use provisions of Section 1(d) of the Trademark Act of 1946, as amended.

SECTION 1.— INTERNATIONAL CLASSIFICATION

The short titles associated below with the international class numbers are terms designed merely for quick identification and are not an official part of the international classification. The full names of international classes are given in section 6.1 of the trademark rules of practice.

The designation "U.S. Cl." appearing in this section refers to the U.S. class in effect prior to Sep. 1, 1973 rather than the international class which applies to applications filed on or after that date. For adoption of international classification see notice in the OFFICIAL GAZETTE of Jun. 26, 1973 (911 O.G. TM 210).

Application in more than one class

4,016,145. OPSEC SECURITY GROUP, INC., DENVER, CO.
SN 76-031,843. PUB. 4-15-2008, FILED 4-20-2000.

4,016,144. ONTARIO LOTTERY AND GAMING CORPORATION, TORONTO, ONTARIO, CANADA. SN 75-123,615.
PUB. 10-20-2009, FILED 6-21-1996.

ARE YOUR BRANDSECURE?

CASINO NIAGARA

PRIORITY CLAIMED UNDER SEC. 44(D) ON CANADA APPLICATION NO. 800395, FILED 12-21-1995, REG. NO. TMA701326, DATED 11-21-2007, EXPIRES 11-21-2022.

NO CLAIM IS MADE TO THE EXCLUSIVE RIGHT TO USE "NIAGARA", APART FROM THE MARK AS SHOWN.

CLASS 18—LEATHER GOODS

FOR LUGGAGE AND LEATHER GOODS, NAMELY, SUITCASES, DUFFEL BAGS, TOTE BAGS, PURSES, WALLETS, KEY CASES, CARD HOLDERS, PORTFOLIOS, BRIEFCASES, BACKPACKS, AND FANNYPACKS (U.S. CLS. 1, 2, 3, 22 AND 41).

FIRST USE 12-7-1996; IN COMMERCE 12-7-1996.

CLASS 25—CLOTHING

FOR CLOTHING, NAMELY, T-SHIRTS, SWEAT SHIRTS, SHIRTS, SHORTS, SKIRTS, PANTS, JACKETS, COATS, SCARVES, TIES, SOCKS, FOOTWEAR, AND HEADWEAR (U.S. CLS. 22 AND 39).

FIRST USE 12-7-1996; IN COMMERCE 12-7-1996.

CLASS 35—ADVERTISING AND BUSINESS

FOR BUSINESS MANAGEMENT IN THE FIELD OF AUTHENTICATION TECHNOLOGY SOLUTIONS FOR COMBATING COUNTERFEITING, DIVERSION, INTELLECTUAL PROPERTY PIRACY, ROYALTY FRAUD AND REMARKING OF PRODUCTS; PROVIDING BUSINESS REPORTS, NAMELY, PROVIDING DATA REGARDING UNAUTHORIZED COMMERCE OF PRODUCTS AND TRACING A BRAND NAME PRODUCT MANUFACTURING SOURCE TO ITS RETAIL DESTINATION (U.S. CLS. 100, 101 AND 102).

FIRST USE 5-13-2009; IN COMMERCE 5-13-2009.

CLASS 42—SCIENTIFIC AND COMPUTER SERVICES

FOR CONSULTATION IN THE FIELD OF ASSESSING AND IMPLEMENTING AUTHENTICATION TECHNOLOGY SOLUTIONS FOR COMBATING COUNTERFEITING, DIVERSION, INTELLECTUAL PROPERTY PIRACY, ROYALTY FRAUD AND REMARKING OF PRODUCTS; MONITORING COMPUTER NETWORKS FOR SECURITY BREACHES; MONITORING AND SEARCHING LOCAL, NATIONAL AND GLOBAL COMPUTER NETWORKS FOR INFORMATION CONCERNING UNAUTHORIZED DISTRIBUTION OF PRODUCTS, UNAUTHORIZED USE OF INTELLECTUAL PROPERTY AND CONFIDENTIAL AND PROPRIETARY INFORMATION, COUNTERFEITING, ROYALTY FRAUD AND REMARKING OF PRODUCTS; CONSULTING SERVICES, NAMELY, EVALUATING, IMPLEMENTING, INSTALLING AND INTEGRATING COMPUTER NETWORK SECURITY SOFTWARE FOR OTHERS (U.S. CLS. 100 AND 101).

FIRST USE 5-13-2009; IN COMMERCE 5-13-2009.

4,016,149. JC ENTERTAINMENT LIGHTING SERVICES, INC., SUN VALLEY, CA. SN 76-691,080. PUB. 12-15-2009, FILED 7-7-2008.

ENLIGHTENOLOGY

THE MARK CONSISTS OF STANDARD CHARACTERS WITHOUT CLAIM TO ANY PARTICULAR FONT, STYLE, SIZE, OR COLOR.

CLASS 35—ADVERTISING AND BUSINESS

FOR LOGISTICS DESIGN AND MANAGEMENT, NAMELY, LOGISTICS MANAGEMENT IN THE FIELDS OF EXHIBIT, STAGE, MARKETING, PROMOTIONAL, THEME, THEATRICAL, CORPORATE PRESENTATION, AND FILM AND TELEVISION PRODUCTION; PROVIDING SIGNAGE STANDS AND SUPPORTS, NAMELY, RENTAL OF SIGNS FOR ADVERTISING PURPOSES (U.S. CLS. 100, 101 AND 102).

FIRST USE 9-30-2009; IN COMMERCE 9-30-2009.

CLASS 37—CONSTRUCTION AND REPAIR

FOR MEDIA CENTER BUILD, NAMELY, BUILDING CONSTRUCTION SERVICES FOR EXHIBIT, STAGE, CONCERT, MARKETING, PROMOTIONAL, THEME, THEATRICAL, CORPORATE PRESENTATION, AND FOR FILM AND TELEVISION PRODUCTION, INSTALLING CARPETS FOR EXHIBIT, STAGE, CONCERT, MARKETING, PROMOTIONAL, THEME, THEATRICAL, CORPORATE PRESENTATION, AND FOR FILM AND TELEVISION PRODUCTION; PROVIDING INSTALLATION AND MAINTENANCE FOR LIGHTING, AUDIO AND VIDEO EQUIPMENT SOLD AND/OR RENTED (U.S. CLS. 100, 103 AND 106).

FIRST USE 9-30-2009; IN COMMERCE 9-30-2009.

CLASS 40—MATERIAL TREATMENT

FOR PROVIDING GENERATORS, NAMELY, RENTAL OF ELECTRIC POWER GENERATORS FOR EXHIBIT, STAGE, CONCERT, MARKETING, PROMOTIONAL, THEME, THEATRICAL, CORPORATE PRESENTATION, AND FOR FILM AND TELEVISION PRODUCTION; PRINTING SUPPORT, NAMELY, INK JET AND WIDE FORMAT ECO-SOLVENT INKJET PRINTING, AND PLOTTING AND SCANNING SERVICES FOR PRODUCTION OF PRESS AREA PHOTO BACKDROPS, BUS SHELTER SIGNAGE, MOVIE POSTER AND CUSTOMER SIGNAGE ON PAPER, VINYL AND OTHER SURFACES FOR EXHIBIT, STAGE CONCERT, MARKETING, PROMOTIONAL, THEME, THEATRICAL, CORPORATE PRESENTATION, AND FOR FILM AND TELEVISION PRODUCTION (U.S. CLS. 100, 103 AND 106).

FIRST USE 9-30-2009; IN COMMERCE 9-30-2009.

CLASS 41—EDUCATION AND ENTERTAINMENT

FOR TRAINING IN CONNECTION WITH THE INSTALLATION AND/OR USE OF LIGHTING, AUDIO, AND/OR VIDEO EQUIPMENT; MOTION PICTURE FILM, CONCERT, THEATRICAL PRODUCTION SERVICES, NAMELY, PRE-VISUALIZATION, STAGING, TRUSS AND RIGGING, GRAPHICS PRESENTATION SUPPORT, NAMELY, PRODUCTION OF SPECIAL EFFECTS INCLUDING MODEL-MAKING SERVICES, COMPUTER-GENERATED IMAGERY AND COMPUTER GENERATED GRAPHICS FOR THE PRODUCTION OF MOTION PICTURES, VIDEOS, AND MOVIE TRAILERS; EVENT PLOTTING, NAMELY, SPECIAL EVENT PLANNING; PROVIDING ELECTRICAL INSTALLATIONS AND THEATRICAL, STUDIO LIGHTING SYSTEMS, NAMELY, RENTAL OF LIGHTING APPARATUS FOR THEATRICAL SETS OR TELEVISION STUDIOS; AUDIO AND VIDEO SERVICES, NAMELY, AUDIO AND VIDEO RECORDING SERVICES; RENTAL OF TELEVISION, MOTION PICTURE, CONCERT AND THEATRICAL SETS, NAMELY, RENTAL OF LIGHTING EQUIPMENT, LIGHTING FIXTURES, LIGHT KITS, CARTS, GRIP AND LAMP STANDS, SPOTLIGHTS, STRIP LIGHTS, LAMP BARS, LED LIGHTING, STROBE LIGHTING, FOG MACHINES, MIRROR BALLS, POWER CABLES, DIMMING CONTROLS, CONTROL CONSOLES, RIGGING HARDWARE, LADDERS, PROPS; TECHNICAL SUPPORT SERVICES, NAMELY, TECHNICAL TRAINING ADVICE RELATED TO THE INSTALLATION AND USE OF LIGHTING, AUDIO, AND VIDEO EQUIPMENT (U.S. CLS. 100, 101 AND 107).

FIRST USE 9-30-2009; IN COMMERCE 9-30-2009.

CLASS 42—SCIENTIFIC AND COMPUTER SERVICES

FOR DRAFTING AND RENDERING OF BLUEPRINTS FOR EXHIBIT, STAGE, CONCERT, MARKETING, PROMOTIONAL, THEME, THEATRICAL, CORPORATE PRESENTATION, AND FOR FILM AND TELEVISION PRODUCTION; GRAPHIC SUPPORT, NAMELY, COMPUTER GRAPHIC DESIGN AND RENDERING SERVICES; LANDSCAPE LIGHTING DESIGN; PROVIDING EQUIPMENT SPECIFICATIONS, NAMELY, TECHNOLOGY CONSULTATION IN THE FIELD OF ASCERTAINING THE COMPATIBILITY, POWER REQUIREMENTS, APPLICATIONS, AND LIMITATIONS FOR LIGHTING, AUDIO AND VIDEO EQUIPMENT; PROVIDING LIGHTING DESIGN AND CONSULTATION FOR EXHIBIT, STAGE, CONCERT, MARKETING, PROMOTIONAL, THEME, THEATRICAL, CORPORATE PRESENTATION, AND FOR FILM AND TELEVISION PRODUCTION (U.S. CLS. 100 AND 101).

FIRST USE 9-30-2009; IN COMMERCE 9-30-2009.

CLASS 45—PERSONAL AND LEGAL SERVICES

FOR SECURITY GUARD SERVICES, NAMELY, CROWD CONTROL TO MAINTAIN PUBLIC SAFETY FOR EXHIBIT, STAGE, CONCERT, MARKETING, PROMOTIONAL, THEME, THEATRICAL, CORPORATE PRESENTATION, AND FOR FILM AND TELEVISION PRODUCTION; PROVIDING SIGNAGE STANDS AND SUPPORTS, NAMELY, RENTAL OF SIGNS FOR PERSONAL MESSAGES; OBTAINING ENVIRONMENTAL, DESIGN, ZONING AND OTHER GOVERNMENTAL PERMITS (U.S. CLS. 100 AND 101).

FIRST USE 9-30-2009; IN COMMERCE 9-30-2009.

4,016,150. TUSKEGEE AIRMEN NATIONAL HISTORICAL MUSEUM, THE, DETROIT, MI. SN 76-692,248. PUB. 2-16-2010, FILED 8-20-2008.



NO CLAIM IS MADE TO THE EXCLUSIVE RIGHT TO USE "THE NATIONAL MUSEUM OF THE TUSKEGEE AIRMEN", APART FROM THE MARK AS SHOWN.

THE COLOR(S) RED, WHITE AND BLUE IS/ARE CLAIMED AS A FEATURE OF THE MARK.

THE MARK CONSISTS OF THE WORDING "THE NATIONAL MUSEUM OF THE TUSKEGEE AIRMEN" IN RED OVER A BLUE CIRCLE WITH A WHITE STAR, THE CIRCLE HAVING A PARTIAL BLUE LINED RECTANGLE OVERLAPPING IT WITH A WHITE BACKGROUND.

CLASS 16—PAPER GOODS AND PRINTED MATTER

FOR PAPER GOODS, NAMELY, BOOKS, ART WORK, LINE DRAWINGS, LITHOGRAPHS, AND CARICATURES CONCERNING THE AFRICAN AMERICAN FIGHTER PILOTS WHO FOUGHT DURING WORLD WAR II (U.S. CLS. 2, 5, 22, 23, 29, 37, 38 AND 50).

FIRST USE 4-1-2010; IN COMMERCE 4-1-2010.

CLASS 25—CLOTHING

FOR CLOTHING, NAMELY, SHIRTS, JACKETS, T-SHIRTS, SWEATSHIRTS, SOCKS, TIES, CAPS, SCARVES, JACKETS, AND SWIM-WEAR (U.S. CLS. 22 AND 39).

FIRST USE 4-1-2010; IN COMMERCE 4-1-2010.

4,016,152. IMAGINE APPAREL GROUP, L.L.C., NEW YORK, NY. SN 76-697,311. PUB. 11-9-2010, FILED 5-8-2009.

AMERICAN BASICS

THE MARK CONSISTS OF STANDARD CHARACTERS WITHOUT CLAIM TO ANY PARTICULAR FONT, STYLE, SIZE, OR COLOR.

SEC. 2(F).

CLASS 9—ELECTRICAL AND SCIENTIFIC APPARATUS

FOR SUNGLASSES (U.S. CLS. 21, 23, 26, 36 AND 38).
FIRST USE 5-0-2010; IN COMMERCE 5-0-2010.

CLASS 18—LEATHER GOODS

FOR BACKPACKS (U.S. CLS. 1, 2, 3, 22 AND 41).
FIRST USE 5-0-2010; IN COMMERCE 5-0-2010.

CLASS 25—CLOTHING

FOR PANTS, SHORTS, TIGHTS, BODY SUITS, LEOTARDS, BIKE SHORTS, LEGGINGS, BIKETARDS, UNITARDS, TANK TOPS, SWEAT SHIRTS, SWEAT PANTS, JOGGING SUITS, SWIMWEAR, BATHING SUITS, SWIM DRESSES, COVER DRESSES, BOARD SHORTS, SWEATERS, JACKETS, HATS, GLOVES, SCARVES, SLIPPERS, FOOTWEAR, ATHLETIC SHOES AND SNEAKERS (U.S. CLS. 22 AND 39).

FIRST USE 5-0-2010; IN COMMERCE 5-0-2010.

4,016,158. TAIWAN EXTERNAL TRADE DEVELOPMENT COUNCIL, TAIPEI, TAIWAN. SN 76-698,791. PUB. 6-15-2010, FILED 8-4-2009.



OWNER OF U.S. REG. NO. 2,784,889.

NO CLAIM IS MADE TO THE EXCLUSIVE RIGHT TO USE "TAIPEI", APART FROM THE MARK AS SHOWN.

THE MARK CONSISTS OF THE WORDING "COMPUTEX TAIPEI" AND THE DESIGN CONSISTING OF SHADED RECTANGLE IN WHICH THE LEFT SIDE OF THE RECTANGLE IS SMALLER THAN THE RIGHT SIDE; INSIDE THE SHADED RECTANGLE IS A RECTANGLE CUT OUT IN WHICH THE RIGHT SIDE OF THE RECTANGLE IS SMALLER THAN THE LEFT SIDE; THE DESIGN IS TO THE LEFT OF THE TERM "COMPUTEX" AND THE TERM "TAIPEI" IS BELOW THE TERM "COMPUTEX".

CLASS 35—ADVERTISING AND BUSINESS

FOR GOODS OR SERVICES PRICE QUOTATIONS; PROVIDING A WEB SITE WHEREBY BUYERS OF GOODS OR SERVICES LOCATE AND RECEIVE QUOTATIONS FROM MULTIPLE COMPETITIVE SOURCES AND SELLERS OF GOODS OR SERVICES IDENTIFY AND BID ON MULTIPLE NEW SALES OPPORTUNITIES; PROVISION OF BUSINESS INFORMATION; PLANNING AND CONDUCTING OF TRADE FAIRS, EXHIBITIONS AND PRESENTATIONS FOR ECONOMIC OR ADVERTISING PURPOSES; ADVERTISING SERVICES IN NEWSPAPERS, MAGAZINES, TELEVISION, RADIO STATION; PUBLICITY AND SALES PROMOTION SERVICES; COMMERCIAL INFORMATION AGENCIES; BUSINESS MARKETING CONSULTING SERVICES; CONDUCTING BUSINESS AND MARKET RESEARCH SURVEYS; ADVERTISING VIA ELECTRONIC MEDIA AND SPECIFICALLY THE INTERNET; DISSEMINATION OF ADVERTISING FOR OTHERS VIA THE INTERNET; ADVERTISING SERVICES, NAMELY, PROMOTING AND MARKETING THE GOODS AND SERVICES OF OTHERS THROUGH ALL PUBLIC COMMUNICATION MEANS (U.S. CLS. 100, 101 AND 102).

FIRST USE 1-7-2010; IN COMMERCE 1-7-2010.

CLASS 41—EDUCATION AND ENTERTAINMENT

FOR EDUCATIONAL SERVICES, NAMELY, PROVIDING SEMINARS, CONFERENCES, WORKSHOPS IN THE FIELD OF INFORMATION AND COMMUNICATION TECHNOLOGY AND EXHIBITION INDUSTRIES; EDUCATIONAL SERVICES, NAMELY, CONDUCTING CLASSES, SEMINARS, CONFERENCES, WORKSHOPS IN THE FIELD OF INFORMATION AND COMMUNICATION TECHNOLOGY AND EXHIBITION INDUSTRIES (U.S. CLS. 100, 101 AND 107).

FIRST USE 1-7-2010; IN COMMERCE 1-7-2010.

4,016,170. GOLD LINE TELEMAGEMENT INC., RICHMOND HILL, CANADA. SN 77-073,672. PUB. 5-25-2010, FILED 12-29-2006.



OWNER OF CANADA REG. NO. TMA755,158, DATED 12-11-2009, EXPIRES 12-11-2024.

NO CLAIM IS MADE TO THE EXCLUSIVE RIGHT TO USE "LIVE LEARNING", APART FROM THE MARK AS SHOWN.

THE MARK CONSISTS OF A GRADUATION CAP ATOP A STYLIZED GLOBE WHICH HAS THE LETTER "E" ON IT, NEXT TO THE WORDS "LIVE LEARNING".

CLASS 41—EDUCATION AND ENTERTAINMENT

FOR INTERACTIVE ELECTRONIC COMMUNICATIONS SERVICES, NAMELY, PROVIDING AN INTERACTIVE EDUCATIONAL WEBSITE FEATURING ON-LINE COURSES OF INSTRUCTION AT THE PRESCHOOL, UNIVERSITY, COLLEGE, PRIMARY SCHOOL, TRADE SCHOOL OR SECONDARY SCHOOL LEVELS (U.S. CLS. 100, 101 AND 107).

FIRST USE 12-2-2009; IN COMMERCE 7-11-2011.

CLASS 42—SCIENTIFIC AND COMPUTER SERVICES

FOR INTERACTIVE ELECTRONIC COMMUNICATIONS SERVICES, NAMELY, HOSTING OF AN INTERACTIVE WEBSITE FEATURING EDUCATIONAL SERVICES IN THE NATURE OF ON-LINE COURSES AT THE PRESCHOOL, UNIVERSITY, COLLEGE, PRIMARY SCHOOL, TRADE SCHOOL OR SECONDARY SCHOOL LEVELS (U.S. CLS. 100 AND 101).

FIRST USE 12-2-2009; IN COMMERCE 7-11-2011.

4,016,176. HARWOOD INTERNATIONAL INCORPORATED, DALLAS, TX. SN 77-145,786. PUB. 4-22-2008, FILED 4-1-2007.

ABOVE ALL ELSE

THE MARK CONSISTS OF STANDARD CHARACTERS WITHOUT CLAIM TO ANY PARTICULAR FONT, STYLE, SIZE, OR COLOR.

CLASS 36—INSURANCE AND FINANCIAL

FOR REAL ESTATE ACQUISITION, INVESTMENT, MANAGEMENT, BROKERAGE, LISTING AND LEASING, ALL AS RELATED TO COMMERCIAL, RESIDENTIAL, RETAIL, AND/OR MIXED-USE REAL PROPERTIES (U.S. CLS. 100, 101 AND 102).

FIRST USE 10-0-2004; IN COMMERCE 10-0-2004.

CLASS 37—CONSTRUCTION AND REPAIR

FOR REAL ESTATE DEVELOPMENT AS RELATED TO COMMERCIAL, RESIDENTIAL, RETAIL AND/OR MIXED USE REAL PROPERTIES (U.S. CLS. 100, 103 AND 106).

FIRST USE 10-0-2004; IN COMMERCE 10-0-2004.

4,016,177. EARTH NETWORKS, INC., GERMANTOWN, MD. SN 77-149,013. PUB. 4-1-2008, FILED 4-4-2007.

TEMPERATURE NEXT TO THE CLOCK

THE MARK CONSISTS OF STANDARD CHARACTERS WITHOUT CLAIM TO ANY PARTICULAR FONT, STYLE, SIZE, OR COLOR.

CLASS 38—COMMUNICATION

FOR TRANSMISSION OF LIVE WEATHER CONDITIONS, WEATHER FORECASTS, WEATHER ALERTS, AND OTHER WEATHER RELATED INFORMATION OVER SATELLITE AND WIRELESS NETWORKS (U.S. CLS. 100, 101 AND 104).

FIRST USE 6-14-2011; IN COMMERCE 6-14-2011.

CLASS 42—SCIENTIFIC AND COMPUTER SERVICES

FOR PROVIDING LIVE WEATHER CONDITIONS, WEATHER FORECASTS, WEATHER ALERTS, AND OTHER WEATHER RELATED INFORMATION OVER SATELLITE, VIDEO AND AUDIO/VIDEO MEDIA, AND WIRELESS NETWORKS (U.S. CLS. 100 AND 101).

FIRST USE 6-14-2011; IN COMMERCE 6-14-2011.

4,016,178. GENAUDIO, INC., CENTENNIAL, CO. SN 77-160,600. PUB. 4-8-2008, FILED 4-19-2007.

ASTOUNDSOUND

THE MARK CONSISTS OF STANDARD CHARACTERS WITHOUT CLAIM TO ANY PARTICULAR FONT, STYLE, SIZE, OR COLOR.

CLASS 35—ADVERTISING AND BUSINESS

FOR POST-PRODUCTION AUDIO EDITING SERVICES FOR COMMERCIALS (U.S. CLS. 100, 101 AND 102).

FIRST USE 10-1-2007; IN COMMERCE 10-1-2007.

CLASS 41—EDUCATION AND ENTERTAINMENT

FOR POST-PRODUCTION AUDIO EDITING SERVICES IN THE FIELD OF MUSIC, VIDEOS AND FILMS; PROVIDING A WEBSITE FEATURING INFORMATION IN THE FIELDS OF AUDIO PRODUCTION, NAMELY, SOUND REPRODUCTION, PROCESSING AND RECORDING (U.S. CLS. 100, 101 AND 107).

FIRST USE 10-1-2007; IN COMMERCE 10-1-2007.

4,016,179. GENAUDIO, INC., ENGLEWOOD, CO. SN 77-160,618. PUB. 4-8-2008, FILED 4-19-2007.



THE MARK CONSISTS OF FOUR CONCENTRIC CIRCLES WITH A WEDGE APPEARING AS AN EXCLAMATION POINT INSERTED IN THE TOP.

CLASS 35—ADVERTISING AND BUSINESS

FOR POST-PRODUCTION AUDIO EDITING SERVICES FOR COMMERCIALS (U.S. CLS. 100, 101 AND 102).

FIRST USE 10-1-2007; IN COMMERCE 10-1-2007.

CLASS 41—EDUCATION AND ENTERTAINMENT

FOR POST-PRODUCTION AUDIO EDITING SERVICES IN THE FIELD OF MUSIC, VIDEOS AND FILMS; PROVIDING A WEBSITE FEATURING INFORMATION IN THE FIELDS OF AUDIO PRODUCTION, NAMELY, SOUND REPRODUCTION, PROCESSING AND RECORDING (U.S. CLS. 100, 101 AND 107).

FIRST USE 10-1-2007; IN COMMERCE 10-1-2007.

4,016,180. GENAUDIO, INC., CENTENNIAL, CO. SN 77-160,640. PUB. 4-8-2008, FILED 4-19-2007.

ASTOUNDSTEREO

THE MARK CONSISTS OF STANDARD CHARACTERS WITHOUT CLAIM TO ANY PARTICULAR FONT, STYLE, SIZE, OR COLOR.

CLASS 35—ADVERTISING AND BUSINESS

FOR POST-PRODUCTION AUDIO EDITING SERVICES FOR COMMERCIALS (U.S. CLS. 100, 101 AND 102).

FIRST USE 1-15-2011; IN COMMERCE 1-15-2011.

CLASS 41—EDUCATION AND ENTERTAINMENT

FOR POST-PRODUCTION AUDIO EDITING SERVICES IN THE FIELD OF MUSIC, VIDEOS AND FILMS; PROVIDING A WEBSITE FEATURING INFORMATION IN THE FIELDS OF AUDIO PRODUCTION, NAMELY, SOUND REPRODUCTION, PROCESSING AND RECORDING (U.S. CLS. 100, 101 AND 107).

FIRST USE 1-15-2011; IN COMMERCE 1-15-2011.

4,016,181. GENAUDIO, INC., CENTENNIAL, CO. SN 77-160,657. PUB. 4-8-2008, FILED 4-19-2007.



THE MARK CONSISTS OF AN EXCLAMATION MARK AND INTERCONNECTED SPIRAL.

CLASS 35—ADVERTISING AND BUSINESS

FOR POST-PRODUCTION AUDIO EDITING SERVICES FOR COMMERCIALS; PROVIDING A WEBSITE FEATURING CONSUMER PRODUCT INFORMATION IN THE FIELD OF SOUND REPRODUCTION, PROCESSING AND RECORDING PRODUCTS AND SERVICES IN THE ENTERTAINMENT, MEDICAL, INFORMATIONAL SYSTEMS, HEALTH, FITNESS AND MILITARY FIELDS (U.S. CLS. 100, 101 AND 102).

FIRST USE 1-15-2011; IN COMMERCE 1-15-2011.

CLASS 41—EDUCATION AND ENTERTAINMENT

FOR POST-PRODUCTION AUDIO EDITING SERVICES IN THE FIELD OF MUSIC, VIDEOS AND FILMS (U.S. CLS. 100, 101 AND 107).

FIRST USE 1-15-2011; IN COMMERCE 1-15-2011.

4,016,182. GENAUDIO, INC., CENTENNIAL, CO. SN 77-160,670. PUB. 4-8-2008, FILED 4-19-2007.

GENAUDIO

THE MARK CONSISTS OF STANDARD CHARACTERS WITHOUT CLAIM TO ANY PARTICULAR FONT, STYLE, SIZE, OR COLOR.

CLASS 35—ADVERTISING AND BUSINESS

FOR POST-PRODUCTION AUDIO EDITING SERVICES FOR COMMERCIALS (U.S. CLS. 100, 101 AND 102).

FIRST USE 1-15-2011; IN COMMERCE 1-15-2011.

CLASS 41—EDUCATION AND ENTERTAINMENT

FOR PROVIDING A WEBSITE FEATURING INFORMATION IN THE FIELDS OF AUDIO PRODUCTION, NAMELY, SOUND REPRODUCTION, PROCESSING AND RECORDING (U.S. CLS. 100, 101 AND 107).

FIRST USE 1-15-2011; IN COMMERCE 1-15-2011.

4,016,183. GENAUDIO, INC., CENTENNIAL, CO. SN 77-160,689. PUB. 4-8-2008, FILED 4-19-2007.



THE MARK CONSISTS OF TWO INTERLOCKING OVALS ABOVE THE WORD "GENAUDIO", WITH A SHARP-ENDED DESIGN INSINUATING THE LETTER "A" WHICH CONSISTS OF A HORIZONTAL LINE BENEATH THE LETTER "N" AND WHICH SLANTS UPWARD INTO A SHARP PEAK, THEN SLANTS DOWNWARD FORMING ANOTHER SHARP PEAK BELOW THE ORIGINAL HORIZONTAL LINE, THEN SLANTS UPWARD AGAIN TO THE SAME LEVEL AS THE ORIGINAL HORIZONTAL LINE AND UNDERLINES THE LETTERS "UDIO".

CLASS 35—ADVERTISING AND BUSINESS

FOR POST-PRODUCTION AUDIO EDITING SERVICES FOR COMMERCIALS (U.S. CLS. 100, 101 AND 102).

FIRST USE 1-15-2011; IN COMMERCE 1-15-2011.

CLASS 41—EDUCATION AND ENTERTAINMENT

FOR POST-PRODUCTION AUDIO EDITING SERVICES IN THE FIELD OF MUSIC, VIDEOS AND FILMS (U.S. CLS. 100, 101 AND 107).

FIRST USE 1-15-2011; IN COMMERCE 1-15-2011.

4,016,186. SIERRA HEALTHSTYLES LLC, TUCSON, AZ. SN 77-181,658. PUB. 3-4-2008, FILED 5-15-2007.

MIRAVAL RESORT

THE MARK CONSISTS OF STANDARD CHARACTERS WITHOUT CLAIM TO ANY PARTICULAR FONT, STYLE, SIZE, OR COLOR.

NO CLAIM IS MADE TO THE EXCLUSIVE RIGHT TO USE "RESORT", APART FROM THE MARK AS SHOWN.

"MIRAVAL" IS A COLLOQUIAL CONTRACTION OF THE SPANISH TRANSLATION OF "VALLEY VIEW."

CLASS 35—ADVERTISING AND BUSINESS

FOR REAL ESTATE MARKETING SERVICES IN THE FIELD OF LUXURY APARTMENTS, CONDOMINIUMS, HOMES, AND BUILDABLE LAND (U.S. CLS. 100, 101 AND 102).

FIRST USE 7-31-2007; IN COMMERCE 7-31-2007.

CLASS 36—INSURANCE AND FINANCIAL

FOR LEASING OF REAL ESTATE; REAL ESTATE ACQUISITION, MANAGEMENT AND CONSULTATION SERVICES; VACATION REAL ESTATE TIME SHARING (U.S. CLS. 100, 101 AND 102).

FIRST USE 7-31-2007; IN COMMERCE 7-31-2007.

CLASS 37—CONSTRUCTION AND REPAIR

FOR REAL ESTATE DEVELOPMENT (U.S. CLS. 100, 103 AND 106).

FIRST USE 7-31-2007; IN COMMERCE 7-31-2007.

4,016,193. HOOZWARE, INC., FOSTER CITY, CA. SN 77-226,087. PUB. 4-15-2008, FILED 7-10-2007.

Hoozware

THE MARK CONSISTS OF STANDARD CHARACTERS WITHOUT CLAIM TO ANY PARTICULAR FONT, STYLE, SIZE, OR COLOR.

CLASS 35—ADVERTISING AND BUSINESS

FOR PROVIDING AN ONLINE DIRECTORY INFORMATION SERVICE FEATURING INFORMATION REGARDING SERVICES, EVENTS, ACTIVITIES, ATTRACTIONS AND FACILITIES (U.S. CLS. 100, 101 AND 102).

FIRST USE 11-22-2005; IN COMMERCE 1-25-2011.

CLASS 45—PERSONAL AND LEGAL SERVICES

FOR ONLINE SOCIAL NETWORKING SERVICES THAT PROVIDE INFORMATION ABOUT THE MEMBERS OF THE SOCIAL NETWORK (U.S. CLS. 100 AND 101).

FIRST USE 11-22-2005; IN COMMERCE 1-25-2011.

4,016,197. SMITHS HEIMANN GMBH, WIESBADEN, FED REP GERMANY. SN 77-267,920. PUB. 4-1-2008, FILED 8-30-2007.

iLane

THE MARK CONSISTS OF STANDARD CHARACTERS WITHOUT CLAIM TO ANY PARTICULAR FONT, STYLE, SIZE, OR COLOR.

CLASS 7—MACHINERY

FOR CONVEYER BELTS FOR BAGGAGE HANDLING (U.S. CLS. 13, 19, 21, 23, 31, 34 AND 35).

FIRST USE 4-0-2008; IN COMMERCE 4-0-2008.

CLASS 9—ELECTRICAL AND SCIENTIFIC APPARATUS

FOR BAGGAGE HANDLING APPARATUS AND EQUIPMENT, NAMELY, ELECTRONIC EQUIPMENT IN THE NATURE OF SENSORS, SCANNERS AND DETECTOR UNITS FOR INSPECTION AND DETECTION OF DRUGS, WEAPONS, EXPLOSIVES, CONTRABAND AND HAZARDOUS ITEMS WITHIN BAGGAGE AND CONTAINERS (U.S. CLS. 21, 23, 26, 36 AND 38).

FIRST USE 4-0-2008; IN COMMERCE 4-0-2008.

CLASS 20—FURNITURE AND ARTICLES NOT OTHERWISE CLASSIFIED

FOR INDUSTRIAL WORK TABLES, DISPLAY STANDS, AND SEATS FOR USE IN HANDLING BAGGAGE AND BY BAGGAGE HANDLERS (U.S. CLS. 2, 13, 22, 25, 32 AND 50).

FIRST USE 4-0-2008; IN COMMERCE 4-0-2008.

4,016,202. JSC "REALORE", VAIDAUGU, LITHUANIA. SN 77-295,155. PUB. 8-26-2008, FILED 10-3-2007.

REALORE

THE MARK CONSISTS OF STANDARD CHARACTERS WITHOUT CLAIM TO ANY PARTICULAR FONT, STYLE, SIZE, OR COLOR.

CLASS 9—ELECTRICAL AND SCIENTIFIC APPARATUS

FOR GAME SOFTWARE; COMPUTER GAME CONSOLES FOR USE WITH AN EXTERNAL DISPLAY SCREEN OR MONITOR; COMPUTER GAME DISCS; COMPUTER GAME EQUIPMENT CONTAINING MEMORY DEVICES, NAMELY, DISCS; COMPUTER GAME PROGRAMS, CARTRIDGES, AND CASSETTES; COMPUTER PROGRAMS FOR VIDEO AND COMPUTER GAMES; DOWNLOADABLE ELECTRONIC GAMES VIA WIRELESS DEVICES; GAME CONTROLLERS FOR COMPUTER GAMES; GAMES ADAPTED FOR USE WITH TELEVISION RECEIVERS; HAND-HELD ELECTRONIC GAMES ADAPTED FOR USE WITH TELEVISION RECEIVERS ONLY; HAND-HELD UNITS FOR PLAYING ELECTRONIC GAMES FOR USE WITH EXTERNAL DISPLAY SCREEN OR MONITOR; INTERACTIVE MULTIMEDIA COMPUTER GAME PROGRAM; VIDEO AND COMPUTER GAME PROGRAMS; VIDEO GAME CARTRIDGES AND DISCS; VIRTUAL REALITY GAME SOFTWARE (U.S. CLS. 21, 23, 26, 36 AND 38).

FIRST USE 1-1-2007; IN COMMERCE 1-1-2007.

CLASS 38—COMMUNICATION

FOR PROVIDING ON-LINE CHAT ROOMS AND ELECTRONIC BULLETIN BOARDS FOR TRANSMISSION OF MESSAGES AMONG USERS IN THE FIELD OF GENERAL INTEREST (U.S. CLS. 100, 101 AND 104).

FIRST USE 1-1-2009; IN COMMERCE 1-1-2009.

CLASS 41—EDUCATION AND ENTERTAINMENT

FOR EDUCATION SERVICES, NAMELY, PROVIDING CLASSES AND WORKSHOPS IN THE FIELDS OF COMPUTERS AND GAMES; PROVIDING OF TRAINING IN THE FIELDS OF COMPUTERS AND VIDEO GAMES, ENTERTAINMENT, NAMELY, NON-DOWNLOADABLE RINGTONES, PRE-RECORDED MUSIC, VIDEO AND GRAPHICS PRESENTED TO MOBILE COMMUNICATIONS DEVICES VIA A GLOBAL COMPUTER NETWORK AND WIRELESS NETWORKS; ORGANIZING COMMUNITY SPORTING AND CULTURAL EVENTS (U.S. CLS. 100, 101 AND 107).

FIRST USE 1-1-2007; IN COMMERCE 1-1-2007.

CLASS 42—SCIENTIFIC AND COMPUTER SERVICES

FOR COMPUTER PROGRAMMING SERVICES; COMPUTER SERVICES, NAMELY, CREATING AN ONLINE COMMUNITY FOR REGISTERED USERS TO PARTICIPATE IN COMPETITIONS, SHOWCASE THEIR SKILLS, GET FEEDBACK FROM THEIR PEERS, FORM VIRTUAL COMMUNITIES, ENGAGE IN SOCIAL NETWORKING AND IMPROVE THEIR TALENT; COMPUTER SOFTWARE CONSULTANCY; RESEARCH, DEVELOPMENT, DESIGN AND UPGRADING OF COMPUTER SOFTWARE; DESIGN AND DEVELOPMENT OF COMPUTER HARDWARE AND SOFTWARE (U.S. CLS. 100 AND 101).

FIRST USE 1-1-2007; IN COMMERCE 1-1-2007.

4,016,204. WOLVERINE WORLD WIDE, INC., ROCKFORD, MI. SN 77-306,974. PUB. 3-11-2008, FILED 10-18-2007.

HUSH PUPPIES HARMONY

THE MARK CONSISTS OF STANDARD CHARACTERS WITHOUT CLAIM TO ANY PARTICULAR FONT, STYLE, SIZE, OR COLOR.

OWNER OF U.S. REG. NOS. 1,358,761, 1,381,201, AND

1,733,837.

CLASS 1—CHEMICALS

FOR FOOTWEAR CARE PRODUCTS, NAMELY, CHEMICAL PREPARATIONS FOR WATERPROOFING, WATER REPELLING, STAIN REPELLING, AND DIRT REPELLING (U.S. CLS. 1, 5, 6, 10, 26 AND 46).
FIRST USE 2-1-2008; IN COMMERCE 2-1-2008.

CLASS 3—COSMETICS AND CLEANING PREPARATIONS

FOR FOOTWEAR CARE PRODUCTS, NAMELY, POLISHES, CREAMS, LEATHER PRESERVATIVES, CLEANING PREPARATIONS, CLEANSERS, SOAPS, STAIN REMOVERS, CONDITIONERS, SCUFF REMOVERS, AND SHOE POLISH APPLICATORS CONTAINING SHOE POLISH (U.S. CLS. 1, 4, 6, 50, 51 AND 52).
FIRST USE 2-1-2008; IN COMMERCE 2-1-2008.

4,016,207. ADVANCED LIGHTING TECHNOLOGIES, INC., SOLON, OH. SN 77-313,564. PUB. 9-23-2008, FILED 10-25-2007.

**CLASS 37—CONSTRUCTION AND REPAIR**

FOR INSTALLATION, MAINTENANCE AND REPAIR OF LIGHTING SYSTEMS (U.S. CLS. 100, 103 AND 106).
FIRST USE 12-0-2002; IN COMMERCE 12-0-2002.

CLASS 42—SCIENTIFIC AND COMPUTER SERVICES

FOR DESIGN FOR OTHERS IN THE FIELD OF LIGHTING SYSTEMS (U.S. CLS. 100 AND 101).
FIRST USE 12-0-2002; IN COMMERCE 12-0-2002.

4,016,223. PLYMOUTH ROCK ASSURANCE CORPORATION, BOSTON, MA. SN 77-340,356. PUB. 3-31-2009, FILED 11-29-2007.

**MYLES - MAKING YOUR LIFE
EASIER SERVICES**

THE MARK CONSISTS OF STANDARD CHARACTERS WITHOUT CLAIM TO ANY PARTICULAR FONT, STYLE, SIZE, OR COLOR.

CLASS 35—ADVERTISING AND BUSINESS

FOR ARRANGING AND CONDUCTING INCENTIVE REWARD PROGRAMS TO PROMOTE THE SALE OF MOTOR VEHICLE AND HOMEOWNERS INSURANCE; PROVIDING CONCIERGE-TYPE SERVICES FOR MOTOR VEHICLE AND HOMEOWNERS INSURANCE POLICYHOLDERS, NAMELY, PROVIDING AN ON-LINE COMPUTER WEB SITE THAT PROVIDES ACCOUNT MANAGEMENT AND CONSUMER INFORMATION REGARDING INSURANCE COVERAGE, VEHICLE AND DRIVER NEEDS, LICENSING AND REGISTRATION, PARKING AND TRANSPORTATION, AND FUEL PRICING AND AVAILABILITY (U.S. CLS. 100, 101 AND 102).
FIRST USE 6-22-2011; IN COMMERCE 6-22-2011.

CLASS 36—INSURANCE AND FINANCIAL

FOR PROVIDING CONCIERGE-TYPE SERVICES FOR MOTOR VEHICLE AND HOMEOWNERS INSURANCE POLICYHOLDERS, NAMELY, BILL PAYMENT SERVICES PROVIDED THROUGH AN ON-LINE COMPUTER WEB SITE (U.S. CLS. 100, 101 AND 102).
FIRST USE 6-22-2011; IN COMMERCE 6-22-2011.

CLASS 38—COMMUNICATION

FOR PROVIDING CONCIERGE-TYPE SERVICES FOR MOTOR VEHICLE AND HOMEOWNERS INSURANCE POLICYHOLDERS, NAMELY, PROVIDING ELECTRONIC DELIVERY OF DOCUMENTS AND INFORMATION (U.S. CLS. 100, 101 AND 104).
FIRST USE 6-22-2011; IN COMMERCE 6-22-2011.

CLASS 45—PERSONAL AND LEGAL SERVICES

FOR PROVIDING CONCIERGE-TYPE SERVICES FOR MOTOR VEHICLE AND HOMEOWNERS INSURANCE POLICYHOLDERS, NAMELY, REMINDER SERVICES IN THE AREA OF DEADLINES FOR INSPECTIONS AND RENEWALS (U.S. CLS. 100 AND 101).
FIRST USE 6-22-2011; IN COMMERCE 6-22-2011.

4,016,231. VICEROY HOTELS, L.L.C., LOS ANGELES, CA. SN 77-350,885. PUB. 5-18-2010, FILED 12-13-2007.

FIFTY

THE MARK CONSISTS OF STANDARD CHARACTERS WITHOUT CLAIM TO ANY PARTICULAR FONT, STYLE, SIZE, OR COLOR.

CLASS 41—EDUCATION AND ENTERTAINMENT

FOR NIGHTCLUB SERVICES; SOCIAL CLUB SERVICES, NAMELY, ARRANGING, ORGANIZING, AND HOSTING SOCIAL AND PRIVATE EVENTS FOR CLUB MEMBERS (U.S. CLS. 100, 101 AND 107).
FIRST USE 5-13-2011; IN COMMERCE 5-13-2011.

CLASS 43—HOTEL AND RESTAURANT SERVICES

FOR RESTAURANT SERVICES; TAVERN SERVICES (U.S. CLS. 100 AND 101).
FIRST USE 5-13-2011; IN COMMERCE 5-13-2011.

4,016,232. THE WITCH'S BREW LLC, PALM HARBOR, FL. SN 77-351,494. PUB. 10-21-2008, FILED 12-13-2007.

THE WITCH'S BREW

THE MARK CONSISTS OF STANDARD CHARACTERS WITHOUT CLAIM TO ANY PARTICULAR FONT, STYLE, SIZE, OR COLOR.

CLASS 35—ADVERTISING AND BUSINESS

FOR RETAIL STORE SERVICES FEATURING SHIRTS, HATS AND BUMPER STICKERS WITH A WITCH THEME (U.S. CLS. 100, 101 AND 102).
FIRST USE 4-27-2007; IN COMMERCE 5-1-2007.

CLASS 43—HOTEL AND RESTAURANT SERVICES

FOR CAFE-RESTAURANTS (U.S. CLS. 100 AND 101).
FIRST USE 4-27-2007; IN COMMERCE 5-1-2007.

4,016,233. DETROIT ENTERTAINMENT, L.L.C., DETROIT, MI. SN 77-351,866. PUB. 5-13-2008, FILED 12-13-2007.



AMNESIA

THE MARK CONSISTS OF A STYLIZED LETTER "A" AND A DOT ABOVE THE WORD "AMNESIA."

CLASS 41—EDUCATION AND ENTERTAINMENT

FOR ENTERTAINMENT IN THE NATURE OF LIVE SHOWS; ENTERTAINMENT IN THE NATURE OF AUDIO-VISUAL EVENTS FEATURING PRE-RECORDED MUSIC AND PRE-RECORDED VIDEO; DISC JOCKEY AND VIDEO DISC JOCKEY SERVICES (U.S. CLS. 100, 101 AND 107).
FIRST USE 5-0-2008; IN COMMERCE 5-0-2008.

CLASS 43—HOTEL AND RESTAURANT SERVICES

FOR RESTAURANT, BAR AND LOUNGE SERVICES (U.S. CLS. 100 AND 101).
FIRST USE 5-0-2008; IN COMMERCE 5-0-2008.

4,016,234. DETROIT ENTERTAINMENT, L.L.C., DETROIT, MI. SN 77-351,869. PUB. 5-13-2008, FILED 12-13-2007.



THE MARK CONSISTS OF A STYLIZED LETTER "A" AND A DOT.

CLASS 41—EDUCATION AND ENTERTAINMENT

FOR ENTERTAINMENT IN THE NATURE OF LIVE SHOWS; ENTERTAINMENT IN THE NATURE OF AUDIO-VISUAL EVENTS FEATURING PRE-RECORDED MUSIC AND PRE-RECORDED VIDEO; DISC JOCKEY AND VIDEO DISC JOCKEY SERVICES (U.S. CLS. 100, 101 AND 107).
FIRST USE 5-0-2008; IN COMMERCE 5-0-2008.

CLASS 43—HOTEL AND RESTAURANT SERVICES

FOR RESTAURANT, BAR AND LOUNGE SERVICES (U.S. CLS. 100 AND 101).
FIRST USE 5-0-2008; IN COMMERCE 5-0-2008.

4,016,246. KERN AG GLOBAL LANGUAGE SERVICES, FRANKFURT, FED REP GERMANY. SN 77-396,196. PUB. 11-16-2010, FILED 2-13-2008.

KERN

THE MARK CONSISTS OF STANDARD CHARACTERS WITHOUT CLAIM TO ANY PARTICULAR FONT, STYLE, SIZE, OR COLOR.

PRIORITY CLAIMED UNDER SEC. 44(D) ON ERP CMNTY TM OFC APPLICATION NO. 006400782, FILED 10-17-2007, REG. NO. 006400782, DATED 11-20-2009, EXPIRES 10-17-2017.

CLASS 35—ADVERTISING AND BUSINESS

FOR PROJECT MANAGING SERVICES FOR OTHERS IN THE FIELDS OF LANGUAGE TRANSLATION AND LANGUAGE INTERPRETING (U.S. CLS. 100, 101 AND 102).
FIRST USE 0-0-1969; IN COMMERCE 6-24-1987.

CLASS 39—TRANSPORTATION AND STORAGE

FOR ARRANGING TRAVEL TOURS, NAMELY, FOREIGN LANGUAGE TOURS (U.S. CLS. 100 AND 105).
FIRST USE 0-0-1999; IN COMMERCE 12-16-2005.

CLASS 40—MATERIAL TREATMENT

FOR FOREIGN LANGUAGE TYPESETTING SERVICES FOR OTHERS (U.S. CLS. 100, 103 AND 106).
FIRST USE 0-0-1969; IN COMMERCE 6-24-1987.

CLASS 41—EDUCATION AND ENTERTAINMENT

FOR LANGUAGE TRANSLATION SERVICES; WEB PAGE AND WEB SITE TRANSLATION SERVICES; TECHNICAL DOCUMENT TRANSLATION SERVICES; DATABASE TRANSLATION SERVICES; AND LANGUAGE INTERPRETING SERVICES; DESKTOP PUBLISHING FOR OTHERS; PROOFREADING SERVICES FOR OTHERS (U.S. CLS. 100, 101 AND 107).
FIRST USE 0-0-1969; IN COMMERCE 6-24-1987.

CLASS 30—STAPLE FOODS

FOR CANDIES AND CHOCOLATES; HAND-CRAFTED CANDY AND CHOCOLATES; CANDY AND CHOCOLATES, NAMELY, CREAMS AND NOUGATS; BOXED CANDIES AND CHOCOLATES; CHOCOLATES, NAMELY, CHOCOLATE NOVELTIES; AND CANDY AND CHOCOLATE BARS; HOT CHOCOLATE (U.S. CL. 46).
FIRST USE 10-1-2009; IN COMMERCE 10-1-2009.

CLASS 35—ADVERTISING AND BUSINESS

FOR WHOLESALE AND RETAIL STORE AND ONLINE WHOLESALE AND RETAIL STORE SERVICES FEATURING CANDY, CHOCOLATES, BOXED CANDIES AND CHOCOLATES, CHOCOLATE NOVELTIES, HOT CHOCOLATE (U.S. CLS. 100, 101 AND 102).
FIRST USE 10-1-2009; IN COMMERCE 10-1-2009.

4,016,248. SIEGEL OIL COMPANY, DENVER, CO. SN 77-406,011. PUB. 9-29-2009, FILED 2-26-2008.



THE MARK CONSISTS OF A STYLIZED "Z" WITH BOTTOM EXTENDED ON TOP OF WHICH ARE THE LETTERS "ENITH".

CLASS 1—CHEMICALS

FOR ANTIFREEZE; COOLANT AND AUTOMATIC TRANSMISSION FLUID FOR MOTOR VEHICLE ENGINES (U.S. CLS. 1, 5, 6, 10, 26 AND 46).
FIRST USE 2-23-2011; IN COMMERCE 2-23-2011.

CLASS 4—LUBRICANTS AND FUELS

FOR AUTOMOBILE LUBRICANTS (U.S. CLS. 1, 6 AND 15).
FIRST USE 2-23-2011; IN COMMERCE 2-23-2011.

4,016,249. NORMAN LOVE CONFECTIONS, INC., FORT MYERS, FL. SN 77-421,713. PUB. 8-5-2008, FILED 3-13-2008.

NORMAN LOVE CONFECTIONS
BLACK

THE MARK CONSISTS OF STANDARD CHARACTERS WITHOUT CLAIM TO ANY PARTICULAR FONT, STYLE, SIZE, OR COLOR.

OWNER OF U.S. REG. NOS. 3,026,858, 3,141,215, AND OTHERS.

NO CLAIM IS MADE TO THE EXCLUSIVE RIGHT TO USE "CONFECTIONS", APART FROM THE MARK AS SHOWN.

THE NAME "NORMAN LOVE" IDENTIFIES A LIVING INDIVIDUAL WHOSE CONSENT IS OF RECORD.

4,016,256. DAVITA INC., DENVER, CO. SN 77-466,732. PUB. 4-14-2009, FILED 5-6-2008.

DAVITA VILLAGEHEALTH

THE MARK CONSISTS OF STANDARD CHARACTERS WITHOUT CLAIM TO ANY PARTICULAR FONT, STYLE, SIZE, OR COLOR.

OWNER OF U.S. REG. NOS. 2,576,733, 2,602,168, AND 2,924,926.

CLASS 16—PAPER GOODS AND PRINTED MATTER

FOR PUBLICATIONS, NAMELY, NEWSLETTERS, PERIODICALS, INFORMATIONAL BROCHURES AND MAGAZINES IN THE FIELD OF KIDNEY DISEASE (U.S. CLS. 2, 5, 22, 23, 29, 37, 38 AND 50).

FIRST USE 12-0-2010; IN COMMERCE 12-0-2010.

CLASS 36—INSURANCE AND FINANCIAL

FOR ADMINISTRATION OF HEALTH CARE SERVICE PLANS FOR OTHERS (U.S. CLS. 100, 101 AND 102).
FIRST USE 10-0-2009; IN COMMERCE 10-0-2009.

CLASS 44—MEDICAL, BEAUTY AND AGRICULTURAL SERVICES

FOR HEALTH CARE SERVICES, NAMELY, KIDNEY DISEASE MANAGEMENT PROGRAMS (U.S. CLS. 100 AND 101).

FIRST USE 10-0-2009; IN COMMERCE 10-0-2009.

4,016,265. BARBOUR ENERGY CORPORATION, OKLAHOMA CITY, OK. SN 77-479,486. PUB. 4-14-2009, FILED 5-20-2008.



NO CLAIM IS MADE TO THE EXCLUSIVE RIGHT TO USE "ENERGY CORPORATION", APART FROM THE MARK AS SHOWN.

THE COLOR(S) BLACK, RED, GRAY, GREEN AND WHITE IS/ARE CLAIMED AS A FEATURE OF THE MARK.

THE MARK CONSISTS OF THE STYLIZED WORDING "BARBOUR ENERGY CORPORATION" AND THE DESIGN OF A GLOBE CONTAINING GRID LINES TO THE LEFT OF THE WORD "ENERGY". THE COLOR BLACK APPEARS IN THE WORDING "BARBOUR", THE COLOR RED APPEARS IN THE WORDING "ENERGY", AND THE COLOR GRAY APPEARS IN THE WORDING "CORPORATION". THE COLOR GREEN APPEARS IN THE DESIGN OF THE GLOBE, AND THE COLOR WHITE APPEARS IN THE GRID LINES WITHIN THE GLOBE.

CLASS 40—MATERIAL TREATMENT

FOR OIL AND GAS PRODUCTION (U.S. CLS. 100, 103 AND 106).
FIRST USE 5-31-2011; IN COMMERCE 5-31-2011.

CLASS 42—SCIENTIFIC AND COMPUTER SERVICES

FOR OIL AND GAS EXPLORATION (U.S. CLS. 100 AND 101).
FIRST USE 5-31-2011; IN COMMERCE 5-31-2011.

4,016,268. RIVERWIRED, INC., NEW YORK, NY. SN 77-484,888. PUB. 3-31-2009, FILED 5-28-2008.

Green Hands USA

THE MARK CONSISTS OF STANDARD CHARACTERS WITHOUT CLAIM TO ANY PARTICULAR FONT, STYLE, SIZE, OR COLOR.

NO CLAIM IS MADE TO THE EXCLUSIVE RIGHT TO USE "GREEN" AND "USA", APART FROM THE MARK AS SHOWN.

CLASS 35—ADVERTISING AND BUSINESS

FOR PROVIDING ONLINE INFORMATION PROMOTING PUBLIC ENVIRONMENTAL AWARENESS; PROVIDING ONLINE INFORMATION IN THE FIELD OF PUBLIC ADVOCACY TO PROMOTE ENVIRONMENTAL AWARENESS; CONDUCTING NATIONAL AND LOCAL VOLUNTEER PROGRAMS IN THE FIELD OF ENVIRONMENTAL AWARENESS; PROVIDING A WEB SITE FEATURING INFORMATION, VIDEO CONTENT AND AUDIO CONTENT, ALL PERTAINING TO PROMOTING PUBLIC ENVIRONMENTAL AWARENESS, PUBLIC ADVOCACY TO PROMOTE ENVIRONMENTAL AWARENESS, AND CONDUCTING NATIONAL AND LOCAL VOLUNTEER PROGRAMS IN THE FIELD OF ENVIRONMENTAL AWARENESS (U.S. CLS. 100, 101 AND 102).
FIRST USE 12-5-2009; IN COMMERCE 12-5-2009.

CLASS 41—EDUCATION AND ENTERTAINMENT

FOR ONLINE INFORMATIONAL SERVICES IN THE FIELD OF ENVIRONMENTAL AWARENESS, NAMELY, CONDUCTING ON-LINE EXHIBITIONS AND DISPLAYS AND INTERACTIVE EXHIBITS IN THE FIELD OF ENVIRONMENTAL AWARENESS; ENTERTAINMENT SERVICES, NAMELY, PROVIDING A WEBSITE FEATURING INFORMATION, VIDEO CONTENT, AND AUDIO CONTENT IN THE FIELD OF CURRENT EVENT NEWS FEATURING ENVIRONMENTAL ISSUES; ON-LINE JOURNALS, NAMELY, BLOGS FEATURING INFORMATION IN THE FIELD OF ENVIRONMENTAL AWARENESS; ENTERTAINMENT SERVICES, NAMELY, PROVIDING ON-LINE COMPUTER GAMES IN THE FIELD OF ENVIRONMENTAL AWARENESS (U.S. CLS. 100, 101 AND 107).
FIRST USE 12-5-2009; IN COMMERCE 12-5-2009.

4,016,271. WINDWARD VENTURES INC., NORTH YORK, ON, CANADA. SN 77-521,111. PUB. 5-11-2010, FILED 7-14-2008.

ECO LUXE

THE MARK CONSISTS OF STANDARD CHARACTERS WITHOUT CLAIM TO ANY PARTICULAR FONT, STYLE, SIZE, OR COLOR.

OWNER OF CANADA REG. NO. TMA758900, DATED 2-5-2010, EXPIRES 2-5-2025.

CLASS 21—HOUSEWARES AND GLASS

FOR SYNTHETIC AND NATURAL FIBRE BODY SCRUB PRODUCTS, NAMELY, SEA SPONGES, LOOFAH, RAMIE, BAMBOO AND SISAL BODY SCRUB SPONGES, BODY SCRUB BRUSHES, NAIL BRUSHES, FOOT BRUSHES, HAIR BRUSHES, TOOTH BRUSHES, COSMETIC BRUSHES, AND EXFOLIATING SLIPPERS; BATH AND SHOWER ACCESSORIES, NAMELY, SOAP DISHES AND SOAP HOLDERS, BATHTUB TRAYS; GIFT BASKETS CONTAINING ONE OR MORE OF THE AFOREMENTIONED SYNTHETIC AND NATURAL FIBRE BODY SCRUB PRODUCTS, NAMELY, SEA SPONGES, LOOFAH, RAMIE, BAMBOO AND SISAL BODY SCRUB SPONGES, BODY SCRUB BRUSHES, NAIL BRUSHES, FOOT BRUSHES, HAIR BRUSHES, TOOTH BRUSHES, COSMETIC BRUSHES, AND EXFOLIATING SLIPPERS (U.S. CLS. 2, 13, 23, 29, 30, 33, 40 AND 50).
FIRST USE 1-31-2007; IN COMMERCE 7-31-2009.

CLASS 25—CLOTHING

FOR SHOWER CAPS, GLOVES AND SOCKS FOR MOISTURIZING; ROBES, HEAD BANDS, TURBANS AND SLIPPERS; GIFT BASKETS CONTAINING ONE OR MORE OF THE AFOREMENTIONED SHOWER CAPS, GLOVES AND SOCKS FOR MOISTURIZING; ROBES, HEAD BANDS, TURBANS AND SLIPPERS (U.S. CLS. 22 AND 39).

FIRST USE 1-31-2007; IN COMMERCE 7-31-2009.

4,016,275. WOLF CREEK PRODUCTIONS, INC., PERRY, MI. SN 77-542,550. PUB. 12-30-2008, FILED 8-8-2008.

Deer City USA

THE MARK CONSISTS OF STANDARD CHARACTERS WITHOUT CLAIM TO ANY PARTICULAR FONT, STYLE, SIZE, OR COLOR.

NO CLAIM IS MADE TO THE EXCLUSIVE RIGHT TO USE "USA", APART FROM THE MARK AS SHOWN.

CLASS 25—CLOTHING

FOR ATHLETIC APPAREL, NAMELY, SHIRTS, PANTS, JACKETS, FOOTWEAR, HATS AND CAPS, ATHLETIC UNIFORMS (U.S. CLS. 22 AND 39).

FIRST USE 9-1-2008; IN COMMERCE 4-1-2009.

CLASS 41—EDUCATION AND ENTERTAINMENT

FOR ENTERTAINMENT IN THE NATURE OF ONGOING TELEVISION PROGRAMS IN THE FIELD OF BIG GAME HUNTING (U.S. CLS. 100, 101 AND 107).

FIRST USE 9-1-2008; IN COMMERCE 9-1-2008.

4,016,277. EMBLEM ENTERPRISES, INC., CHATSWORTH, CA. SN 77-585,567. PUB. 11-9-2010, FILED 10-3-2008.

Guardian Gear

THE MARK CONSISTS OF STANDARD CHARACTERS WITHOUT CLAIM TO ANY PARTICULAR FONT, STYLE, SIZE, OR COLOR.

NO CLAIM IS MADE TO THE EXCLUSIVE RIGHT TO USE "GEAR", APART FROM THE MARK AS SHOWN.

CLASS 6—METAL GOODS

FOR ATTACHMENTS TO BELTS, NAMELY, CASES AND POUCHES FOR HANDCUFFS; METAL CLIPS FOR ATTACHING HANDCUFFS TO BELTS; GEAR HOLSTERS FOR STORING HANDCUFFS (U.S. CLS. 2, 12, 13, 14, 23, 25 AND 50).

FIRST USE 5-15-2011; IN COMMERCE 5-15-2011.

CLASS 13—FIREARMS

FOR BANDOLIERS FOR HOLDING CARTRIDGES OR AMMUNITION CASES; CARTRIDGE BELTS; CARTRIDGE CASES; CARTRIDGE POUCHES; CARTRIDGE SHOT POUCHES; CASE COVERS FOR FIREARMS; COVERS FOR FIREARMS; FIREARM SLINGS; GUN AND RIFLE CASES; GUN BELTS; GUN CASES; PISTOL HOLSTERS; HOLSTERS; SLING STRAPS FOR FIREARMS; ATTACHMENTS TO BELTS, NAMELY, CASES AND POUCHES FOR AMMUNITION AND FOR WEAPONS IN THE NATURE OF PISTOLS, GUNS, PEPPER SPRAY AND ELECTRO-MUSCULAR DISRUPTION DEVICES IN THE NATURE OF STUN GUNS; GEAR HOLSTERS FOR STORING WEAPONS IN THE NATURE OF PISTOLS, GUNS, PEPPER SPRAY AND ELECTRO-MUSCULAR DISRUPTION DEVICES IN THE NATURE OF STUN GUNS (U.S. CLS. 2 AND 9).

FIRST USE 5-15-2011; IN COMMERCE 5-15-2011.

4,016,285. NATIONAL ELECTRICAL MANUFACTURERS ASSOCIATION, ROSSLYN, VA. SN 77-616,410. PUB. 11-30-2010, FILED 11-18-2008.

ENLIGHTEN AMERICA

THE MARK CONSISTS OF STANDARD CHARACTERS WITHOUT CLAIM TO ANY PARTICULAR FONT, STYLE, SIZE, OR COLOR.

NO CLAIM IS MADE TO THE EXCLUSIVE RIGHT TO USE "AMERICA", APART FROM THE MARK AS SHOWN.

CLASS 35—ADVERTISING AND BUSINESS

FOR COMPUTERIZED ONLINE SERVICES FOR THE LIGHTING MANUFACTURING INDUSTRY IN THE NATURE OF A VIRTUAL TRADE SHOW FEATURING GOODS AND TECHNOLOGIES RELATING TO LIGHTING PRODUCTS; SALES PROMOTION FOR COMPANIES IN THE LIGHTING MANUFACTURING INDUSTRY; DISSEMINATION OF ADVERTISING MATERIALS FOR THE LIGHTING MANUFACTURING INDUSTRY RELATING TO LIGHTING PRODUCTS; ARRANGING TRADE SHOW EXHIBITIONS FOR THE LIGHTING MANUFACTURING INDUSTRY RELATED TO LIGHTING PRODUCTS VIA THE INTERNET (U.S. CLS. 100, 101 AND 102).

FIRST USE 8-0-2008; IN COMMERCE 8-0-2008.

CLASS 38—COMMUNICATION

FOR TRANSMISSION AND DISTRIBUTION OF AUDIO-VISUAL PROGRAMS FOR THE LIGHTING MANUFACTURING INDUSTRY RELATING TO LIGHTING PRODUCTS VIA THE INTERNET AND OTHER MEDIA (U.S. CLS. 100, 101 AND 104).

FIRST USE 8-0-2008; IN COMMERCE 8-0-2008.

CLASS 41—EDUCATION AND ENTERTAINMENT

FOR PROVIDING TRAINING IN THE FORM OF SEMINARS AND WORKSHOPS IN THE FIELD OF LIGHTING MANUFACTURING GOODS RELATING TO LIGHTING PRODUCTS; ORGANIZING AND CONDUCTING CONFERENCES, SEMINARS, AND SYMPOSIUMS, IN VIRTUAL FORM AND OTHER ENTITIES' FORUMS, FOR THE LIGHTING MANUFACTURING INDUSTRY TO PROVIDE TRAINING EDUCATION IN THE FIELD OF GOODS AND TECHNOLOGIES RELATED TO LIGHTING PRODUCTS; PUBLICATION OF PRINTED MATTER NOT FOR ADVERTISING PURPOSES RELATING TO LIGHTING PRODUCTS FROM AND FOR THE LIGHTING MANUFACTURING INDUSTRY; WRITING OF TEXTS, OTHER THAN PUBLICITY TEXTS, RELATING TO LIGHTING PRODUCTS FROM AND FOR THE LIGHTING MANUFACTURING INDUSTRY; ORGANIZING AND CONDUCTING EDUCATIONAL AND TECHNICAL SEMINARS AND CONFERENCES RELATING TO LIGHTING PRODUCTS FROM AND FOR THE LIGHTING MANUFACTURING INDUSTRY VIA THE INTERNET AND IN OTHER ENTITIES' FORUMS; ONLINE PUBLICATION OF MATERIALS FOR THE LIGHTING MANUFACTURING INDUSTRY ABOUT LIGHTING PRODUCTS FOR COMMERCIAL AND ADVERTISING PURPOSES (U.S. CLS. 100, 101 AND 107).

FIRST USE 8-0-2008; IN COMMERCE 8-0-2008.

CLASS 42—SCIENTIFIC AND COMPUTER SERVICES

FOR TECHNICAL CONSULTATION AND RESEARCH IN THE FIELD OF INTEGRATED CIRCUIT MEMORY PRODUCT DESIGN; DESIGN FOR OTHERS IN THE FIELD OF INTEGRATED CIRCUIT MEMORY PRODUCTS; DEVELOPING VOLUNTARY STANDARDS FOR OTHERS RELATING TO THE MANUFACTURE, DESIGN, AND MARKETING OF INTEGRATED CIRCUIT MEMORY PRODUCTS; PRODUCT RESEARCH AND DEVELOPMENT, NAMELY, TECHNICAL RESEARCH IN THE FIELD OF INTEGRATED CIRCUIT MEMORY PRODUCT MANUFACTURING (U.S. CLS. 100 AND 101).

FIRST USE 12-0-2005; IN COMMERCE 12-0-2005.

4,016,289. TATE INCORPORATED, ALEXANDRIA, VA. SN 77-623,537. PUB. 9-15-2009, FILED 12-1-2008.

4,016,287. CHINGIS TECHNOLOGY CORPORATION, SAN JOSE, CA. SN 77-620,571. PUB. 1-4-2011, FILED 11-24-2008.

pFusion

THE MARK CONSISTS OF STANDARD CHARACTERS WITHOUT CLAIM TO ANY PARTICULAR FONT, STYLE, SIZE, OR COLOR.

CLASS 35—ADVERTISING AND BUSINESS

FOR CONSULTATION AND RESEARCH IN THE FIELD OF INTEGRATED CIRCUIT MEMORY PRODUCT MARKETING; COMMERCIAL ADMINISTRATION OF THE LICENSING OF TECHNOLOGY AND KNOW-HOW RELATING TO INTEGRATED CIRCUIT MEMORY PRODUCTS OF OTHERS (U.S. CLS. 100, 101 AND 102).

FIRST USE 12-0-2005; IN COMMERCE 12-0-2005.

CLASS 40—MATERIAL TREATMENT

FOR TECHNICAL CONSULTATION IN THE FIELD OF INTEGRATED CIRCUIT MEMORY PRODUCT MANUFACTURING (U.S. CLS. 100, 103 AND 106).

FIRST USE 4-1-2009; IN COMMERCE 4-1-2009.

ENGINEERED SURVIVAL

THE MARK CONSISTS OF STANDARD CHARACTERS WITHOUT CLAIM TO ANY PARTICULAR FONT, STYLE, SIZE, OR COLOR.

CLASS 9—ELECTRICAL AND SCIENTIFIC APPARATUS

FOR TRACKING DEVICES, NAMELY, COMPUTER HARDWARE AND SOFTWARE FOR TRACKING PEOPLE AND OBJECTS USING GPS DATA ON A DEVICE ON THE TRACKED PEOPLE AND OBJECTS; WIRELESS TRANSCEIVERS WITH COLLECTION AND DISPLAY TECHNOLOGY FOR THE STATUS AND TRACKING OF ALL VEHICLE TYPES IN LOCAL ENVIRONMENTS; RADIO FREQUENCY DEVICES, NAMELY, GROUND TO AIR SIGNALING DEVICES THAT ILLUMINATE UPON COMMAND OF THE INDIVIDUAL IN WIRELESS TRANSCEIVERS WITH COLLECTION, DISPLAY, AND SIGNALING TECHNOLOGY THAT SERVE TO ALERT AND CONVEY MESSAGES TO AIRCRAFT PILOTS IN THE EVENT OF EMERGENCY RESCUE SITUATIONS; GLOBAL POSITIONING SYSTEM AND SIGNALING DEVICES, NAMELY, CELLULAR BASED OR SATELLITE BASED FOR TRACKING PEOPLE AND OBJECTS USING GPS DATA ON A DEVICE ON THE TRACKED PEOPLE AND OBJECTS, WIRELESS TRANSCEIVERS WITH COLLECTION AND DISPLAY TECHNOLOGY FOR THE STATUS AND TRACKING OF ALL VEHICLE TYPES IN LOCAL ENVIRONMENTS (U.S. CLS. 21, 23, 26, 36 AND 38).

FIRST USE 6-13-2011; IN COMMERCE 6-13-2011.

CLASS 41—EDUCATION AND ENTERTAINMENT

FOR PROVIDING TRAINING FOR GOVERNMENT AND MILITARY HIGH RISK OPERATIONS IN THE FIELDS OF SURVIVAL, EVASION, RESISTANCE AND ESCAPE; PERSONNEL RECOVERY TRAINING (U.S. CLS. 100, 101 AND 107).

FIRST USE 9-1-2008; IN COMMERCE 9-1-2008.

4,016,291. FRIED, FRANK, HARRIS, SHRIVER & JACOBSON LLP, NEW YORK, NY. SN 77-634,457. PUB. 9-15-2009, FILED 12-16-2008.

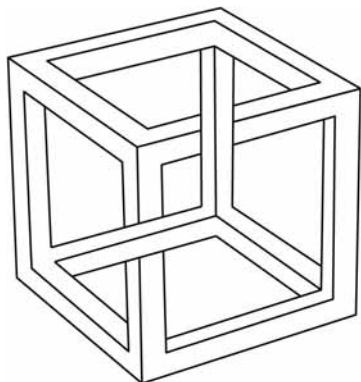

THE MARK CONSISTS OF A THREE-DIMENSIONAL OPEN CUBE.

CLASS 9—ELECTRICAL AND SCIENTIFIC APPARATUS

FOR DOWNLOADABLE ELECTRONIC MATERIALS AND PUBLICATIONS, NAMELY, BROCHURES, NEWSLETTERS, EDUCATIONAL MATERIALS IN THE NATURE OF MANUALS, INFORMATIONAL TEXTS, PRESENTATIONS, WORKSHEETS, GUIDES, AND VIDEOS, MEMORANDA AND OTHER COMMUNICATIONS IN THE NATURE OF INFORMATIONAL FLYERS, ELECTRONIC INVITATIONS, AND BROCHURES WITH CLIENTS, POTENTIAL CLIENTS, EMPLOYEES, POTENTIAL EMPLOYEES, AND MEDIA, AND PROFESSIONAL ARTICLES CONCERNING LEGAL ISSUES (U.S. CLS. 21, 23, 26, 36 AND 38).

FIRST USE 2-0-2010; IN COMMERCE 2-0-2010.

CLASS 16—PAPER GOODS AND PRINTED MATTER

FOR PRINTED MATERIALS AND PUBLICATIONS, NAMELY, BROCHURES, NEWSLETTERS, EDUCATIONAL MATERIALS IN THE NATURE OF MANUALS, INFORMATIONAL TEXTS, PRESENTATIONS, WORKSHEETS, AND GUIDES, MEMORANDA, AND OTHER COMMUNICATIONS IN THE NATURE OF INFORMATIONAL FLYERS, PRINTED INVITATIONS, AND BROCHURES WITH CLIENTS, POTENTIAL CLIENTS, EMPLOYEES, POTENTIAL EMPLOYEES, AND MEDIA, AND PROFESSIONAL ARTICLES CONCERNING LEGAL ISSUES (U.S. CLS. 2, 5, 22, 23, 29, 37, 38 AND 50).

FIRST USE 2-0-2010; IN COMMERCE 2-0-2010.

CLASS 41—EDUCATION AND ENTERTAINMENT

FOR NON-DOWNLOADABLE ELECTRONIC MATERIALS AND PUBLICATIONS, NAMELY, BROCHURES, NEWSLETTERS, EDUCATIONAL MATERIALS IN THE NATURE OF MANUALS, INFORMATIONAL TEXTS, PRESENTATIONS, WORKSHEETS, GUIDES, AND VIDEOS, MEMORANDA AND OTHER COMMUNICATIONS IN THE NATURE OF INFORMATIONAL FLYERS, ELECTRONIC INVITATIONS, AND BROCHURES WITH CLIENTS, POTENTIAL CLIENTS, EMPLOYEES, POTENTIAL EMPLOYEES, AND MEDIA, AND PROFESSIONAL ARTICLES CONCERNING LEGAL ISSUES (U.S. CLS. 100, 101 AND 107).

FIRST USE 2-0-2010; IN COMMERCE 2-0-2010.

CLASS 45—PERSONAL AND LEGAL SERVICES

FOR LEGAL SERVICES (U.S. CLS. 100 AND 101).
FIRST USE 2-0-2010; IN COMMERCE 2-0-2010.

4,016,293. FRANK L. STILE M.D., PC, LAS VEGAS, NV. SN 77-639,524. PUB. 5-25-2010, FILED 12-23-2008.

ESTHETIQUE PLASTIQUE

THE MARK CONSISTS OF STANDARD CHARACTERS WITHOUT CLAIM TO ANY PARTICULAR FONT, STYLE, SIZE, OR COLOR.

THE ENGLISH TRANSLATION OF "ESTHETIQUE PLASTIQUE" IN THE MARK IS "AESTHETIC PLASTIC".

CLASS 3—COSMETICS AND CLEANING PREPARATIONS

FOR NON-MEDICATED SKIN CARE PRODUCTS, NAMELY, LOTIONS, MOISTURIZERS, CONDITIONERS, CLARIFIERS, CLEANSERS, OILS, EMOLLIENTS, PREPARATIONS, SOAPS, TONERS, AND CREAMS; NON-MEDICATED ACNE TREATMENT PREPARATIONS; EXFOLIANTS FOR SKIN; SOAPS, SHAMPOOS AND CONDITIONERS; SKIN LIGHTENERS; SKIN CARE PREPARATIONS, NAMELY, BODY POLISH AND CHEMICAL PEELS FOR SKIN; SKIN LIGHTENING AND WHITENING CREAMS AND PREPARATIONS (U.S. CLS. 1, 4, 6, 50, 51 AND 52).

FIRST USE 2-25-2008; IN COMMERCE 2-25-2008.

CLASS 44—MEDICAL, BEAUTY AND AGRICULTURAL SERVICES

FOR HEALTH SPA SERVICES, NAMELY, COSMETIC BODY CARE SERVICES (U.S. CLS. 100 AND 101).

FIRST USE 5-28-2009; IN COMMERCE 5-28-2009.

4,016,300. MARTHA STEWART LIVING OMNIMEDIA, INC., NEW YORK, NY. SN 77-662,996. PUB. 11-2-2010, FILED 2-4-2009.

MARTHA WRAP

THE MARK CONSISTS OF STANDARD CHARACTERS WITHOUT CLAIM TO ANY PARTICULAR FONT, STYLE, SIZE, OR COLOR.

OWNER OF U.S. REG. NOS. 2,793,075 AND 3,455,782.

NO CLAIM IS MADE TO THE EXCLUSIVE RIGHT TO USE "WRAP", APART FROM THE MARK AS SHOWN.

THE NAME(S), PORTRAIT(S), AND/OR SIGNATURE(S) SHOWN IN THE MARK IDENTIFIES "MARTHA" STEWART, WHOSE CONSENT(S) TO REGISTER IS MADE OF RECORD.

CLASS 6—METAL GOODS

FOR PARCHMENT PAPER-LINED ALUMINUM FOIL PAPER (U.S. CLS. 2, 12, 13, 14, 23, 25 AND 50).

FIRST USE 9-1-2010; IN COMMERCE 9-1-2010.

CLASS 16—PAPER GOODS AND PRINTED MATTER

FOR ALUMINUM FOIL PAPER-LINED PARCHMENT PAPER (U.S. CLS. 2, 5, 22, 23, 29, 37, 38 AND 50).
FIRST USE 9-1-2010; IN COMMERCE 9-1-2010.

4,016,327. WESTFIELD, LLC, LOS ANGELES, CA. SN 77-730,474. PUB. 7-13-2010, FILED 5-6-2009.

4,016,311. COLORQUICK, LLC, PENNSAUKEN, NJ. SN 77-687,339. PUB. 10-6-2009, FILED 3-10-2009.

WEB-TO-WORLD

THE MARK CONSISTS OF STANDARD CHARACTERS WITHOUT CLAIM TO ANY PARTICULAR FONT, STYLE, SIZE, OR COLOR.

CLASS 39—TRANSPORTATION AND STORAGE

FOR ELECTRONIC STORAGE AND DISTRIBUTION OF DOCUMENTS, FILES, DATA, PHOTOGRAPHS, AND VIDEOS FOR OTHERS (U.S. CLS. 100 AND 105).
FIRST USE 12-0-2010; IN COMMERCE 12-0-2010.

CLASS 42—SCIENTIFIC AND COMPUTER SERVICES

FOR PROVIDING A WEB SITE THAT GIVES MULTIPLE COMPUTER USERS SIMULTANEOUSLY THE ABILITY TO UPLOAD, CREATE, EDIT, AND STORE DOCUMENTS (U.S. CLS. 100 AND 101).
FIRST USE 12-0-2010; IN COMMERCE 12-0-2010.

4,016,312. NEVIS INDUSTRIES LLC, WILMINGTON, DE. SN 77-688,592. PUB. 2-16-2010, FILED 3-11-2009.



THE MARK CONSISTS OF A CAPITAL "N" INSIDE OF A HORIZONTAL OVAL CIRCLE.

CLASS 6—METAL GOODS

FOR RAILCAR CASTINGS MADE OF METAL (U.S. CLS. 2, 12, 13, 14, 23, 25 AND 50).
FIRST USE 9-3-2010; IN COMMERCE 9-28-2010.

CLASS 12—VEHICLES

FOR STRUCTURAL COMPONENTS FOR RAILCARS (U.S. CLS. 19, 21, 23, 31, 35 AND 44).
FIRST USE 2-19-2010; IN COMMERCE 9-27-2010.

W FAMILY

THE MARK CONSISTS OF STANDARD CHARACTERS WITHOUT CLAIM TO ANY PARTICULAR FONT, STYLE, SIZE, OR COLOR.

NO CLAIM IS MADE TO THE EXCLUSIVE RIGHT TO USE "FAMILY", APART FROM THE MARK AS SHOWN.

CLASS 35—ADVERTISING AND BUSINESS

FOR MEMBERSHIP CLUB SERVICES FOR SHOPPING CENTER PATRONS PROVIDING DISCOUNTS TO MEMBERS ON GOODS AND SERVICES PROVIDED BY OTHERS AND PROVIDING PREFERRED PARKING; CUSTOMER LOYALTY SERVICES FOR PROMOTIONAL PURPOSES (U.S. CLS. 100, 101 AND 102).
FIRST USE 6-0-2009; IN COMMERCE 6-0-2009.

CLASS 41—EDUCATION AND ENTERTAINMENT

FOR PROVIDING CHILDREN'S PLAY AREAS; PROVIDING CHILDREN'S ACTIVITY AREAS AT SHOPPING CENTERS; ENTERTAINMENT IN THE NATURE OF PLANNING CHILDREN'S PARTIES AND CONDUCTING ARTS AND CRAFTS EVENTS IN THE NATURE OF WORKSHOPS FOR CHILDREN; PROVIDING SHOPPING MALL FAMILY LOUNGE FACILITIES FOR SHOPPER RELAXATION (U.S. CLS. 100, 101 AND 107).
FIRST USE 6-0-2009; IN COMMERCE 6-0-2009.

CLASS 43—HOTEL AND RESTAURANT SERVICES

FOR PROVIDING FAMILY DINING AREAS IN SHOPPING MALLS (U.S. CLS. 100 AND 101).
FIRST USE 6-0-2009; IN COMMERCE 6-0-2009.

CLASS 45—PERSONAL AND LEGAL SERVICES

FOR CONCIERGE SERVICES FOR SHOPPING CENTER PATRONS COMPRISING MAKING REQUESTED PERSONAL ARRANGEMENTS AND RESERVATIONS AND PROVIDING CUSTOMER-SPECIFIC INFORMATION TO MEET INDIVIDUAL NEEDS RENDERED TOGETHER IN A SHOPPING CENTER (U.S. CLS. 100 AND 101).
FIRST USE 6-0-2009; IN COMMERCE 6-0-2009.

4,016,330. AMERICAN TECHNOLOGIES, INC., ORANGE, CA. SN 77-731,781. PUB. 12-7-2010, FILED 5-7-2009.



NO CLAIM IS MADE TO THE EXCLUSIVE RIGHT TO USE "AMERICAN TECHNOLOGIES, INC.", APART FROM THE MARK AS SHOWN.

THE MARK CONSISTS OF A STRIPED BANNER PRECEDING THE INITIALS "ATI" PLACED WITHIN A PARTIAL CRESCENT SHAPE WITH THE WORDS "AMERICAN TECHNOLOGIES, INC." BELOW THE LOGO.

CLASS 37—CONSTRUCTION AND REPAIR

FOR RENOVATION AND RESTORATIONS OF BUILDINGS; ENVIRONMENTAL REMEDIATION SERVICES, NAMELY, WASTE DISPOSAL; CLEANING OF BUILDINGS AND THE CONTENTS THEREIN; HAZARDOUS WASTE DISPOSAL SERVICES; BUILDING CONSTRUCTION AND REPAIR; ASBESTOS REMOVAL (U.S. CLS. 100, 103 AND 106).

FIRST USE 9-8-2008; IN COMMERCE 9-8-2008.

CLASS 40—MATERIAL TREATMENT

FOR ENVIRONMENTAL REMEDIATION SERVICES, NAMELY, SOIL AND WASTE TREATMENT SERVICES; MOLD REMEDIATION SERVICES (U.S. CLS. 100, 103 AND 106).

FIRST USE 9-8-2008; IN COMMERCE 9-8-2008.

4,016,336. NORTHERN TOOL & EQUIPMENT COMPANY, INC., BURNSVILLE, MN. SN 77-743,222. PUB. 10-5-2010, FILED 5-22-2009.

KLUTCH

THE MARK CONSISTS OF STANDARD CHARACTERS WITHOUT CLAIM TO ANY PARTICULAR FONT, STYLE, SIZE, OR COLOR.

CLASS 7—MACHINERY

FOR POWER TOOLS, NAMELY, DRILLS, CORDLESS DRILLS, DRILL PRESSES, HAND AND BENCH GRINDERS, HAMMER DRILLS, SANDERS; RECIPROCATING SAWS, SCREW DRIVERS, CHOP SAWS, CIRCULAR SAWS, MITER SAWS, SHARPENERS, ELECTRIC NAILING GUNS, POWER OPERATED TOOLS, NAMELY, BUFFERS; PADS FOR BUFFING MACHINES; POWER DRILL BITS; DRILL CHUCKS FOR POWER DRILLS; AIR-POWERED TOOLS, NAMELY, AIR CUTTING TOOLS, AIR DRILLS, AIR GRINDERS, AIR HAMMERS, AIR IMPACT SOCKET WRENCHES, AIR RATCHET KITS, CONSISTING OF SOCKETS, SOCKET EXTENSIONS AND RATCHET HEADS; AIR-OPERATED POWER TOOLS, NAMELY, SANDERS, SAWS, NEEDLE SCALERS AND COMPONENTS, NAMELY, REPLACEMENT SCALERS AND BITS FOR THE AIR NEEDLE SCALERS, AIR SHEARS, AIR IMPACT WRENCHES; AIR-POWER DRILL BITS; CHUCKS FOR AIR POWERED DRILLS; AIR NAILING GUNS; AIR RATCHET WRENCHES; AIR RIVET GUNS; ENGINES FOR USE WITH POWER OPERATED EQUIPMENT AND TOOLS, OTHER THAN FOR LAND VEHICLES (U.S. CLS. 13, 19, 21, 23, 31, 34 AND 35).

FIRST USE 10-31-2009; IN COMMERCE 10-31-2009.

CLASS 8—HAND TOOLS

FOR HAND TOOLS, NAMELY, ENGRAVERS, SOCKET SETS (U.S. CLS. 23, 28 AND 44).

FIRST USE 10-31-2009; IN COMMERCE 10-31-2009.

CLASS 20—FURNITURE AND ARTICLES NOT OTHERWISE CLASSIFIED

FOR NON-METAL TOOL BOXES; NON-METAL TOOL CHESTS; NON-METAL STORAGE CABINETS FOR TOOLS; SHELVES FOR STORAGE; METAL STORAGE CABINETS; STORAGE RACKS; SHELVING AND COMPONENT PARTS THEREOF, NAMELY, SHELVES AND BRACKETS SOLD AS A UNIT; GARAGE CABINETS; STORAGE RACKS AND SHELVING (U.S. CLS. 2, 13, 22, 25, 32 AND 50).

FIRST USE 10-31-2009; IN COMMERCE 10-31-2009.

4,016,350. THE READER'S DIGEST ASSOCIATION, INC., WHITE PLAINS, NY. SN 77-755,444. PUB. 5-18-2010, FILED 6-9-2009.

ENGLISH20

THE MARK CONSISTS OF STANDARD CHARACTERS WITHOUT CLAIM TO ANY PARTICULAR FONT, STYLE, SIZE, OR COLOR.

OWNER OF U.S. REG. NO. 3,350,571.

CLASS 9—ELECTRICAL AND SCIENTIFIC APPARATUS

FOR AUDIO AND VIDEO RECORDINGS ON THE SUBJECT OF ENGLISH LANGUAGE LEARNING (U.S. CLS. 21, 23, 26, 36 AND 38).

FIRST USE 1-20-2011; IN COMMERCE 1-20-2011.

CLASS 16—PAPER GOODS AND PRINTED MATTER

FOR INSTRUCTIONAL AND TEACHING MATERIALS ON THE SUBJECT OF ENGLISH LANGUAGE LEARNING, NAMELY, A WORKBOOK (U.S. CLS. 2, 5, 22, 23, 29, 37, 38 AND 50).

FIRST USE 1-20-2011; IN COMMERCE 1-20-2011.

CLASS 41—EDUCATION AND ENTERTAINMENT

FOR EDUCATIONAL SERVICES, NAMELY, PROVIDING ON-LINE ENGLISH LANGUAGE INSTRUCTION (U.S. CLS. 100, 101 AND 107).

FIRST USE 11-15-2010; IN COMMERCE 11-15-2010.

4,016,351. ENSIGN GROUP INTERNATIONAL, PROVO, UT.
SN 77-755,702. PUB. 10-20-2009, FILED 6-9-2009.



THE MARK CONSISTS OF LOWER CASE "T" AND "E" WITH THE "E" SEATED WITHIN THE "T".

CLASS 16—PAPER GOODS AND PRINTED MATTER

FOR DAILY PLANNERS, TIME PLANNERS, NOTE-BOOKS (U.S. CLS. 2, 5, 22, 23, 29, 37, 38 AND 50).
FIRST USE 6-9-2009; IN COMMERCE 7-1-2010.

CLASS 18—LEATHER GOODS

FOR TOTE BAGS AND BUSINESS CASES (U.S. CLS. 1, 2, 3, 22 AND 41).
FIRST USE 6-9-2009; IN COMMERCE 7-1-2010.

CLASS 39—TRANSPORTATION AND STORAGE

FOR CONSULTATION IN THE FIELD OF ENERGY EFFICIENT LIGHT RAIL TRANSPORTATION; PUBLIC UTILITY SERVICES IN THE NATURE OF ELECTRICITY AND NATURAL GAS DISTRIBUTION; PROVISION OF INFORMATION IN THE FIELD OF ENERGY DISTRIBUTION, ENERGY EFFICIENT TRANSPORTATION, LIGHT RAIL TRANSPORTATION (U.S. CLS. 100 AND 105).

FIRST USE 8-21-2009; IN COMMERCE 8-21-2009.

CLASS 41—EDUCATION AND ENTERTAINMENT

FOR EDUCATIONAL SERVICES, NAMELY, CONDUCTING LIVE AND ONLINE CLASSES, SEMINARS, WORKSHOPS, AND CONFERENCES IN THE FIELDS OF ENERGY, THE ENVIRONMENT, AND THE CONSERVATION OF RESOURCES, ENERGY EFFICIENT TRANSPORTATION, LIGHT RAIL TRANSPORTATION AND DISTRIBUTING COURSE MATERIALS IN CONNECTION THEREWITH, EDUCATIONAL SERVICES, NAMELY, PROVIDING CLASSES, SEMINARS, WORKSHOPS IN THE FIELDS OF ENERGY, POWER TRANSMISSION AND NEEDS THEREFOR, ENERGY EFFICIENT TRANSPORTATION, LIGHT RAIL TRANSPORTATION AND UTILITY REGULATION (U.S. CLS. 100, 101 AND 107).

FIRST USE 8-21-2009; IN COMMERCE 8-21-2009.

CLASS 42—SCIENTIFIC AND COMPUTER SERVICES

FOR TECHNOLOGICAL CONSULTATION IN THE TECHNOLOGY FIELDS OF ELECTRICITY TRANSMISSION INFRASTRUCTURE, ENERGY EFFICIENT TRANSPORTATION, LIGHT RAIL TRANSPORTATION (U.S. CLS. 100 AND 101).

FIRST USE 8-21-2009; IN COMMERCE 8-21-2009.

4,016,357. XCEL ENERGY INC., MINNEAPOLIS, MN. SN 77-760,147. PUB. 5-4-2010, FILED 6-15-2009.

ENERGY INNOVATION CORRIDOR

THE MARK CONSISTS OF STANDARD CHARACTERS WITHOUT CLAIM TO ANY PARTICULAR FONT, STYLE, SIZE, OR COLOR.

NO CLAIM IS MADE TO THE EXCLUSIVE RIGHT TO USE "ENERGY" AND "CORRIDOR", APART FROM THE MARK AS SHOWN.

CLASS 35—ADVERTISING AND BUSINESS

FOR CONSULTATION IN THE FIELD OF ENERGY EFFICIENCY; PROMOTING PUBLIC AWARENESS OF THE NEED FOR ENERGY CONSERVATION AND EFFICIENT ELECTRICITY UTILIZATION, ENERGY EFFICIENT TRANSPORTATION, LIGHT RAIL TRANSPORTATION AND ENERGY COST ANALYSIS; LOBBYING SERVICES, NAMELY, PROMOTING THE INTERESTS OF ELECTRIC POWER COMPANIES AND THEIR CUSTOMERS IN THE FIELDS OF LEGISLATION, CONSUMER EDUCATION, CONSUMER PUBLIC RELATIONS, REGULATION, ENERGY, POWER TRANSMISSION AND NEEDS THEREFOR, ENERGY EFFICIENT TRANSPORTATION, LIGHT RAIL TRANSPORTATION (U.S. CLS. 100, 101 AND 102).

FIRST USE 8-21-2009; IN COMMERCE 8-21-2009.

4,016,358. THE AMERICAN ISRAEL PUBLIC AFFAIRS COMMITTEE, WASHINGTON, DC. SN 77-760,479. PUB. 11-16-2010, FILED 6-16-2009.

THE AMERICAN ISRAEL PUBLIC AFFAIRS COMMITTEE

THE MARK CONSISTS OF STANDARD CHARACTERS WITHOUT CLAIM TO ANY PARTICULAR FONT, STYLE, SIZE, OR COLOR.

NO CLAIM IS MADE TO THE EXCLUSIVE RIGHT TO USE "COMMITTEE", APART FROM THE MARK AS SHOWN.

SEC. 2(F).

CLASS 16—PAPER GOODS AND PRINTED MATTER

FOR PUBLICATIONS, NAMELY, BROCHURES, HAND-OUTS, NEWSLETTERS, REPORTS AND OTHER PRINTED MATTER IN THE FIELD OF PROMOTING THE RELATIONSHIP BETWEEN THE UNITED STATES AND ISRAEL ON A BROAD RANGE OF TOPICS (U.S. CLS. 2, 5, 22, 23, 29, 37, 38 AND 50).

FIRST USE 0-0-1963; IN COMMERCE 0-0-1963.

CLASS 35—ADVERTISING AND BUSINESS

FOR ASSOCIATION SERVICES, NAMELY, PROMOTING THE INTERESTS OF AMERICANS INTERESTED IN MAINTAINING AND IMPROVING FRIENDSHIP AND GOODWILL BETWEEN THE UNITED STATES AND ISRAEL; POLITICAL LOBBYING IN SUPPORT OF THE RELATIONSHIP OF THE UNITED STATES AND ISRAEL (U.S. CLS. 100, 101 AND 102).

FIRST USE 0-0-1963; IN COMMERCE 0-0-1963.

CLASS 41—EDUCATION AND ENTERTAINMENT

FOR PUBLICATION OF BROCHURES, HAND-OUTS, NEWSLETTERS, REPORTS AND OTHER PRINTED MATTER FOR THE PRESS AND MEDIA IN THE FIELD OF PROMOTING THE RELATIONSHIP BETWEEN THE UNITED STATES AND ISRAEL; EDUCATIONAL CONFERENCES RELATING TO THE RELATIONSHIP BETWEEN THE UNITED STATES AND ISRAEL (U.S. CLS. 100, 101 AND 107).

FIRST USE 0-0-1963; IN COMMERCE 0-0-1963.

4,016,361. AMERICAN BANKNOTE CORPORATION, FORT LEE, NJ. SN 77-767,848. PUB. 5-18-2010, FILED 6-25-2009.

ABNOTE

THE MARK CONSISTS OF STANDARD CHARACTERS WITHOUT CLAIM TO ANY PARTICULAR FONT, STYLE, SIZE, OR COLOR.

CLASS 9—ELECTRICAL AND SCIENTIFIC APPARATUS

FOR MAGNETICALLY ENCODED PLASTIC TRANSACTION CARDS FOR USE AS CREDIT CARDS, DEBIT CARDS, GIFT CARDS, LOYALTY CARDS, DRIVERS' LICENSES, TRANSIT PASSES, IDENTIFICATION CARDS, PROMOTIONAL CARDS, SECURITY ACCESS CARDS, AND FREQUENT BUYER INCENTIVE CARDS (U.S. CLS. 21, 23, 26, 36 AND 38).

FIRST USE 2-22-2011; IN COMMERCE 2-22-2011.

CLASS 16—PAPER GOODS AND PRINTED MATTER

FOR NON-MAGNETICALLY ENCODED PLASTIC TRANSACTION CARDS FOR USE AS LOYALTY CARDS, MEMBERSHIP CARDS, PROMOTIONAL CARDS AND IDENTIFICATION CARDS, SECURITY DOCUMENTS, NAMELY, BONDS, TITLES, AND CERTIFICATES OF ORIGIN, AND BANK CHECKS (U.S. CLS. 2, 5, 22, 23, 29, 37, 38 AND 50).

FIRST USE 2-22-2011; IN COMMERCE 2-22-2011.

4,016,363. AMERICAN BANKNOTE CORPORATION, FORT LEE, NJ. SN 77-768,310. PUB. 5-18-2010, FILED 6-25-2009.



THE MARK CONSISTS OF THE STYLIZED WORD "ABNOTE" WITH UPPER AND LOWER ARCUATE DESIGNS.

CLASS 9—ELECTRICAL AND SCIENTIFIC APPARATUS

FOR MAGNETICALLY ENCODED PLASTIC TRANSACTION CARDS FOR USE AS CREDIT CARDS, DEBIT CARDS, GIFT CARDS, LOYALTY CARDS, DRIVERS' LICENSES, TRANSIT PASSES, IDENTIFICATION CARDS, PROMOTIONAL CARDS, SECURITY ACCESS CARDS, AND FREQUENT BUYER INCENTIVE CARDS (U.S. CLS. 21, 23, 26, 36 AND 38).

FIRST USE 2-22-2011; IN COMMERCE 2-22-2011.

CLASS 16—PAPER GOODS AND PRINTED MATTER

FOR NON-MAGNETICALLY ENCODED PLASTIC TRANSACTION CARDS FOR USE AS LOYALTY CARDS, MEMBERSHIP CARDS, PROMOTIONAL CARDS AND IDENTIFICATION CARDS, SECURITY DOCUMENTS, NAMELY, BONDS, TITLES, AND CERTIFICATES OF ORIGIN, AND BANK CHECKS (U.S. CLS. 2, 5, 22, 23, 29, 37, 38 AND 50).

FIRST USE 2-22-2011; IN COMMERCE 2-22-2011.

4,016,366. TARGET BRANDS, INC., MINNEAPOLIS, MN. SN 77-773,735. PUB. 10-20-2009, FILED 7-2-2009.

GARDEN PLACE

THE MARK CONSISTS OF STANDARD CHARACTERS WITHOUT CLAIM TO ANY PARTICULAR FONT, STYLE, SIZE, OR COLOR.

OWNER OF U.S. REG. NOS. 2,712,561, 3,674,108, AND OTHERS.

NO CLAIM IS MADE TO THE EXCLUSIVE RIGHT TO USE "GARDEN", APART FROM THE MARK AS SHOWN.

CLASS 6—METAL GOODS

FOR STATUES OF NON-PRECIOUS METAL (U.S. CLS. 2, 12, 13, 14, 23, 25 AND 50).

FIRST USE 1-31-2008; IN COMMERCE 1-31-2008.

CLASS 20—FURNITURE AND ARTICLES NOT OTHERWISE CLASSIFIED

FOR STATUES OF RESIN, PLASTIC, WOOD; WIND CHIMES (U.S. CLS. 2, 13, 22, 25, 32 AND 50).

FIRST USE 1-31-2008; IN COMMERCE 1-31-2008.

CLASS 21—HOUSEWARES AND GLASS

FOR STATUES OF FIBERGLASS, GLASS (U.S. CLS. 2, 13, 23, 29, 30, 33, 40 AND 50).
FIRST USE 1-31-2008; IN COMMERCE 1-31-2008.

4,016,386. THE DIABETES ASSOCIATION OF GREATER CLEVELAND, CLEVELAND, OH. SN 77-803,638. PUB. 5-18-2010, FILED 8-13-2009.

4,016,376. YESHIVA UNIVESITY, NEW YORK, NY. SN 77-792,627. PUB. 6-15-2010, FILED 7-29-2009.



OWNER OF U.S. REG. NOS. 2,785,597 AND 2,842,255.
NO CLAIM IS MADE TO THE EXCLUSIVE RIGHT TO USE "UNIVERSITY", APART FROM THE MARK AS SHOWN.

THE HEBREW NAME RABBI ISAAC ELCHANAN DOES NOT IDENTIFY A LIVING INDIVIDUAL.

THE MARK CONSISTS OF THE ENGLISH WORDS "YESHIVA UNIVERSITY", A SHIELD DESIGN, A SCROLL DESIGN REPRESENTING THE TORAH, AND HEBREW WORDING WHICH TRANSLATES TO "RABBI ISAAC ELCHANAN YESHIVA" (ACROSS THE TOP OF THE SHIELD) AND "TORAH" AND "KNOWLEDGE" (IN THE CENTER OF THE SCROLL DESIGN).

THE NON-LATIN CHARACTERS IN THE MARK TRANSLITERATE TO "TORAH, UHMA DAH" AND "YESHIVAT R YITZHAK ELCHANAN". "UHMA DAH" TRANSLATES TO "KNOWLEDGE" IN ENGLISH AND "YESHIVAT R YITZHAK ELCHANAN" TRANSLATES TO "RABBI ISAAC ELCHANAN YESHIVA" IN ENGLISH.

CLASS 9—ELECTRICAL AND SCIENTIFIC APPARATUS

FOR COMPUTER BAGS (U.S. CLS. 21, 23, 26, 36 AND 38).
FIRST USE 5-31-2010; IN COMMERCE 5-31-2010.

CLASS 18—LEATHER GOODS

FOR TOTE BAGS, MESSENGER BAGS AND BACKPACKS (U.S. CLS. 1, 2, 3, 22 AND 41).
FIRST USE 5-31-2010; IN COMMERCE 5-31-2010.

CLASS 25—CLOTHING

FOR CLOTHING, NAMELY, SWEATSHIRTS, T-SHIRTS (U.S. CLS. 22 AND 39).
FIRST USE 5-31-2010; IN COMMERCE 5-31-2010.

CLASS 44—MEDICAL, BEAUTY AND AGRICULTURAL SERVICES

FOR COUNSELING SERVICES IN THE FIELDS OF MENTAL HEALTH, PSYCHIATRIC MEDICATION MANAGEMENT, MEDICAL CRISIS MANAGEMENT AND MEDICAL EMERGENCY SERVICES; HEALTH CENTER SERVICES (U.S. CLS. 100 AND 101).
FIRST USE 8-31-2008; IN COMMERCE 8-31-2008.

DIABETES MATTERS

THE MARK CONSISTS OF STANDARD CHARACTERS WITHOUT CLAIM TO ANY PARTICULAR FONT, STYLE, SIZE, OR COLOR.

NO CLAIM IS MADE TO THE EXCLUSIVE RIGHT TO USE "DIABETES", APART FROM THE MARK AS SHOWN.

CLASS 35—ADVERTISING AND BUSINESS

FOR PROVIDING INFORMATION REGARDING PUBLIC POLICY ACTIVITIES TO PROMOTE PUBLIC INTEREST AND AWARENESS OF DIABETES-RELATED ISSUES; PROMOTING PUBLIC AWARENESS OF DIABETES MANAGEMENT BY ARRANGING AND CONDUCTING SPORTS EVENTS AND CULTURAL ACTIVITIES; PROVIDING BUSINESS AND COMMERCIAL INFORMATION ON DIABETES PREVENTION AND CONTROL, NAMELY, PROVIDING INFORMATION REGARDING CONSUMER PRODUCTS FOR DIABETES PREVENTION AND CONTROL (U.S. CLS. 100, 101 AND 102).
FIRST USE 11-0-2009; IN COMMERCE 11-0-2009.

CLASS 36—INSURANCE AND FINANCIAL

FOR CHARITABLE FUNDRAISING SERVICES (U.S. CLS. 100, 101 AND 102).
FIRST USE 12-0-2009; IN COMMERCE 12-0-2009.

CLASS 41—EDUCATION AND ENTERTAINMENT

FOR CONDUCTING PROFESSIONAL, FAMILIAL, AND PATIENT EDUCATION PROGRAMS ON DIABETES; EDUCATIONAL SERVICES, NAMELY, CONDUCTING PRESENTATIONS AND CLASSES IN THE FIELD OF DIABETES MANAGEMENT AND SELF HELP RELATED TO DIABETES, AND DISSEMINATION OF MATERIALS RELATED THERETO; PROVIDING ONLINE NEWSLETTERS IN THE FIELD OF DIABETES MANAGEMENT, NEWS, AND INFORMATION; COUNSELING IN THE FIELD OF PHYSICAL FITNESS RELATING TO CHANGING ONES LIFESTYLE FOR DIABETES PREVENTION AND MANAGEMENT (U.S. CLS. 100, 101 AND 107).
FIRST USE 12-0-2008; IN COMMERCE 12-0-2008.

CLASS 44—MEDICAL, BEAUTY AND AGRICULTURAL SERVICES

FOR PROVIDING HEALTH AND NUTRITIONAL INFORMATION ON DIABETES PREVENTION AND CONTROL; PROVIDING DIABETES RISK ASSESSMENTS; COUNSELING SERVICES IN THE FIELDS OF HEALTH, NUTRITION AND LIFESTYLE WELLNESS RELATING TO CHANGING ONES LIFESTYLE FOR DIABETES PREVENTION AND MANAGEMENT (U.S. CLS. 100 AND 101).
FIRST USE 3-0-2010; IN COMMERCE 3-0-2010.

4,016,397. AMSCOT CORPORATION, TAMPA, FL. SN 77-822,702. PUB. 8-3-2010, FILED 9-9-2009.



The Money Superstore

OWNER OF U.S. REG. NOS. 2,889,003 AND 3,492,596.

NO CLAIM IS MADE TO THE EXCLUSIVE RIGHT TO USE "THE MONEY SUPERSTORE", APART FROM THE MARK AS SHOWN.

THE MARK CONSISTS OF A SHADED RECTANGLE CONTAINING THE WORD "AMSCOT" ABOVE THE WORDING "THE MONEY SUPERSTORE".

CLASS 35—ADVERTISING AND BUSINESS

FOR TAX PREPARATION SERVICES (U.S. CLS. 100, 101 AND 102).

FIRST USE 9-1-2009; IN COMMERCE 9-1-2009.

CLASS 36—INSURANCE AND FINANCIAL

FOR FINANCIAL SERVICES FOR OTHERS, NAMELY, CHECK CASHING, DEFERRED DEPOSIT TRANSACTION AND MONEY ORDER SERVICES (U.S. CLS. 100, 101 AND 102).

FIRST USE 9-1-2009; IN COMMERCE 9-1-2009.

4,016,399. AMERICAN MANAGEMENT SERVICES, LLC, DALLAS, TX. SN 77-825,888. PUB. 12-7-2010, FILED 9-14-2009.

CREST

THE MARK CONSISTS OF STANDARD CHARACTERS WITHOUT CLAIM TO ANY PARTICULAR FONT, STYLE, SIZE, OR COLOR.

CLASS 35—ADVERTISING AND BUSINESS

FOR FEDERAL HOUSING PROGRAM COMPLIANCE SERVICES, NAMELY, REVIEWING AND AUDITING OPERATIONS OF PROPERTIES TO EVALUATE ELIGIBILITY FOR FEDERAL AFFORDABLE HOUSING PROGRAMS AND FEDERAL LOW-INCOME HOUSING PROGRAMS (U.S. CLS. 100, 101 AND 102).

FIRST USE 5-6-2004; IN COMMERCE 5-6-2004.

CLASS 41—EDUCATION AND ENTERTAINMENT

FOR TRAINING AND EDUCATION, NAMELY, CLASSES, SEMINARS AND WORKSHOPS IN THE FIELD OF COMPLIANCE WITH REQUIREMENTS FOR ELIGIBILITY FOR FEDERAL AFFORDABLE HOUSING PROGRAMS AND FEDERAL LOW-INCOME HOUSING PROGRAMS (U.S. CLS. 100, 101 AND 107).

FIRST USE 5-6-2004; IN COMMERCE 5-6-2004.

4,016,400. AMERICAN MANAGEMENT SERVICES, LLC, DALLAS, TX. SN 77-825,905. PUB. 12-7-2010, FILED 9-14-2009.



NO CLAIM IS MADE TO THE EXCLUSIVE RIGHT TO USE "COMPLIANCE", APART FROM THE MARK AS SHOWN.

THE MARK CONSISTS OF THE WORDS "CREST" AND "COMPLIANCE" WITH A STYLIZED TRIANGLE.

CLASS 35—ADVERTISING AND BUSINESS

FOR FEDERAL HOUSING PROGRAM COMPLIANCE SERVICES, NAMELY, REVIEWING AND AUDITING OPERATIONS OF PROPERTIES TO EVALUATE ELIGIBILITY FOR FEDERAL AFFORDABLE HOUSING PROGRAMS AND FEDERAL LOW-INCOME HOUSING PROGRAMS (U.S. CLS. 100, 101 AND 102).

FIRST USE 7-0-2010; IN COMMERCE 7-0-2010.

CLASS 41—EDUCATION AND ENTERTAINMENT

FOR TRAINING AND EDUCATION, NAMELY, CLASSES, SEMINARS AND WORKSHOPS IN THE FIELD OF COMPLIANCE WITH REQUIREMENTS FOR ELIGIBILITY FOR FEDERAL AFFORDABLE HOUSING PROGRAMS AND FEDERAL LOW-INCOME HOUSING PROGRAMS (U.S. CLS. 100, 101 AND 107).

FIRST USE 7-0-2010; IN COMMERCE 7-0-2010.

4,016,402. MOORE, MINYON, WASHINGTON, DC. SN 77-829,954. PUB. 2-16-2010, FILED 9-18-2009.

BlogOnSisters.com
BlogOnSistahs.com

THE MARK CONSISTS OF STANDARD CHARACTERS WITHOUT CLAIM TO ANY PARTICULAR FONT, STYLE, SIZE, OR COLOR.

CLASS 35—ADVERTISING AND BUSINESS

FOR ADVERTISING AND BUSINESS SERVICES, NAMELY, PROVIDING AN ONLINE WEBSITES WHERE ADVERTISERS, MARKETERS, AND CONTENT PROVIDERS CAN INTERACT WITH USERS FOR ADVERTISING, BRANDING, AND PROMOTING KNOWLEDGE, PRODUCTS, AND SERVICES, AND TRADESHOWS, ON BEHALF OF THEMSELVES AND OTHERS, AND FOR EVALUATING AND RATING THE SAME, ALL THE FOREGOING RELEVANT TO HUMAN ACTIVITIES AFFECTING CLIMATE CHANGE AND RELATED FIELDS; ADVERTISING AND DIRECTORY SERVICES, NAMELY, PROMOTING THE SERVICES OF OTHERS BY PROVIDING A WEB PAGE FEATURING LINKS TO THE WEBSITES OF OTHERS; PROMOTION, ADVERTISING AND MARKETING OF ON-LINE WEBSITES; PROVIDING ADVERTISING SERVICE TO DISTRIBUTE ADVERTISEMENTS FOR DISPLAY ON INTERNET, NAMELY, IN WEBSITES, SOCIAL CONVERSATIONS OVER THE INTERNET, EMAILS, MICROBLOGS, BLOGS, ELECTRONIC MESSAGES, INSTANT MESSAGES, TEXT MESSAGES, MULTIMEDIA MESSAGES, SOCIAL NETWORKS, STATUS UPDATES, FORUMS, ELECTRONIC BULLETIN BOARDS.; PROVIDING AN INTERNET WEBSITE FEATURING NEWS AND INFORMATION IN THE FIELD OF NATIONAL AND INTERNATIONAL POLITICS; PROVISION OF SPACE ON WEBSITES FOR ADVERTISING GOODS AND SERVICES (U.S. CLS. 100, 101 AND 102).

FIRST USE 6-6-2011; IN COMMERCE 6-6-2011.

CLASS 41—EDUCATION AND ENTERTAINMENT

FOR ENTERTAINMENT SERVICES, NAMELY, PROVIDING A WEBSITE AT WHICH THE GENERAL PUBLIC CAN RECEIVE ADVICE FROM AN INDIVIDUAL CONCERNING RELATIONSHIPS, SUCH ADVICE BEING FOR ENTERTAINMENT PURPOSES ONLY; ONLINE JOURNALS, NAMELY, BLOGS FEATURING LIFESTYLE TOPICS ABOUT WOMEN (U.S. CLS. 100, 101 AND 107).

FIRST USE 6-6-2011; IN COMMERCE 6-6-2011.

CLASS 42—SCIENTIFIC AND COMPUTER SERVICES

FOR PROVIDING A WEBSITE ALLOWING USERS TO UPLOAD AND DOWNLOAD MUSIC; PROVIDING A WEBSITE THAT GIVES USERS THE ABILITY TO CREATE CUSTOMIZED WEB PAGES FEATURING USER-DEFINED PROFILES (U.S. CLS. 100 AND 101).

FIRST USE 6-6-2011; IN COMMERCE 6-6-2011.

CLASS 45—PERSONAL AND LEGAL SERVICES

FOR ONLINE SOCIAL NETWORKING SERVICES PROVIDED THROUGH A FASHION COMMUNITY WEBSITE; PROVIDING A RESOURCE WEBSITE FEATURING INFORMATION IN THE FIELD OF SELF-DEVELOPMENT; PROVIDING A RESOURCE WEBSITE PROVIDING INFORMATION IN THE FIELD OF PERSONAL DEVELOPMENT; PROVIDING A SOCIAL NETWORKING WEBSITE FOR ENTERTAINMENT PURPOSES (U.S. CLS. 100 AND 101).

FIRST USE 6-6-2011; IN COMMERCE 6-6-2011.

4,016,413. STANWORTH DEVELOPMENT LIMITED, TORTOLA, BR.VIRGIN ISLANDS. SN 77-844,846. PUB. 10-12-2010, FILED 10-8-2009.

COOL HAND

THE MARK CONSISTS OF STANDARD CHARACTERS WITHOUT CLAIM TO ANY PARTICULAR FONT, STYLE, SIZE, OR COLOR.

CLASS 9—ELECTRICAL AND SCIENTIFIC APPARATUS

FOR DOWNLOADABLE GAMING SOFTWARE USED FOR THE OPERATION OF GAMES OF CHANCE, GAMES OF SKILL AND CASINO STYLE GAMES, NAMELY, POKER GAMES RENDERED ONLINE (U.S. CLS. 21, 23, 26, 36 AND 38).

FIRST USE 3-0-2011; IN COMMERCE 3-0-2011.

CLASS 41—EDUCATION AND ENTERTAINMENT

FOR EDUCATIONAL SERVICES, NAMELY, PROVIDING INSTRUCTIONAL INFORMATION ON POKER; ENTERTAINMENT SERVICES, NAMELY, PROVIDING GAMES OF CHANCE, GAMES OF SKILL AND CASINO STYLE GAMES (U.S. CLS. 100, 101 AND 107).

FIRST USE 3-0-2011; IN COMMERCE 3-0-2011.

4,016,414. STANWORTH DEVELOPMENT LIMITED, TORTOLA, BR.VIRGIN ISLANDS. SN 77-844,861. PUB. 10-12-2010, FILED 10-8-2009.



NO CLAIM IS MADE TO THE EXCLUSIVE RIGHT TO USE "POKER", APART FROM THE MARK AS SHOWN.

THE MARK CONSISTS OF THE WORDING "COOL HAND" WITH A SPARKLE AT THE TOP OF THE LETTERS "C", "H", AND "D". BENEATH THIS WORDING IS THE WORD "POKER" WITH EACH LETTER DISPLAYED ON A PLAYING CARD. TO THE RIGHT OF THE WORDING IS A WOMAN RESTING HER HAND ON THE LETTER "R" IN "POKER". THE BACKGROUND IS AN ABSTRACT DESIGN OF STRIPES AND CLOUDS.

CLASS 9—ELECTRICAL AND SCIENTIFIC APPARATUS

FOR DOWNLOADABLE GAMING SOFTWARE USED FOR THE OPERATION OF GAMES OF CHANCE, GAMES OF SKILL AND CASINO STYLE GAMES, NAMELY, POKER GAMES RENDERED ONLINE (U.S. CLS. 21, 23, 26, 36 AND 38).

FIRST USE 3-0-2011; IN COMMERCE 3-0-2011.

CLASS 41—EDUCATION AND ENTERTAINMENT

FOR EDUCATIONAL SERVICES, NAMELY, PROVIDING INSTRUCTIONAL INFORMATION ON POKER; ENTERTAINMENT SERVICES, NAMELY, PROVIDING GAMES OF CHANCE, GAMES OF SKILL AND CASINO STYLE GAMES (U.S. CLS. 100, 101 AND 107).

FIRST USE 3-0-2011; IN COMMERCE 3-0-2011.

4,016,415. NASUNI CORPORATION, NATICK, MA. SN 77-845,412. PUB. 10-5-2010, FILED 10-9-2009.



THE MARK CONSISTS OF THE WORD "NASUNI" TOGETHER WITH A SET OF INTERSECTING OVALS OVER THE LETTER "I".

THE WORDING "NASUNI" HAS NO MEANING IN A FOREIGN LANGUAGE.

CLASS 9—ELECTRICAL AND SCIENTIFIC APPARATUS

FOR DOWNLOADABLE COMPUTER SOFTWARE FOR PROVIDING ACCESS TO THIRD PARTY DATA STORAGE PROVIDERS (U.S. CLS. 21, 23, 26, 36 AND 38).

FIRST USE 2-10-2010; IN COMMERCE 2-10-2010.

CLASS 38—COMMUNICATION

FOR PROVIDING ACCESS TO THIRD PARTY DATA STORAGE PROVIDERS, NAMELY, PROVIDING USERS OF DATA STORAGE SYSTEMS WITH DOWNLOADABLE SOFTWARE THAT EXECUTES IN THE USER'S DATA STORAGE SYSTEM TOGETHER WITH A WEB-BASED MANAGEMENT INTERFACE THROUGH WHICH THE USER'S FILES ARE SECURELY DELIVERED TO AND RETRIEVED FROM THE THIRD PARTY DATA STORAGE PROVIDERS (U.S. CLS. 100, 101 AND 104).

FIRST USE 2-10-2010; IN COMMERCE 2-10-2010.

CLASS 42—SCIENTIFIC AND COMPUTER SERVICES

FOR COMPUTER SERVICES, NAMELY, MONITORING AND REPORTING ON THE PERFORMANCE AND AVAILABILITY OF THIRD PARTY DATA STORAGE PROVIDERS (U.S. CLS. 100 AND 101).

FIRST USE 2-10-2010; IN COMMERCE 2-10-2010.

4,016,417. CTR NEWS, LLC, MESA, AZ. SN 77-847,419. PUB. 3-23-2010, FILED 10-13-2009.

THE MARK CONSISTS OF STANDARD CHARACTERS WITHOUT CLAIM TO ANY PARTICULAR FONT, STYLE, SIZE, OR COLOR.

CLASS 38—COMMUNICATION

FOR COMMUNICATION SERVICES, NAMELY, TRANSMISSION OF VOICE, AUDIO, VISUAL IMAGES AND DATA BY TELECOMMUNICATIONS NETWORKS, WIRELESS COMMUNICATION NETWORKS, THE INTERNET, INFORMATION SERVICES NETWORKS AND DATA NETWORKS; COMMUNICATIONS SERVICES, NAMELY, TRANSMITTING STREAMED SOUND AND AUDIOVISUAL RECORDINGS VIA THE INTERNET; ELECTRONIC TRANSMISSION AND STREAMING OF DIGITAL MEDIA CONTENT FOR OTHERS VIA GLOBAL AND LOCAL COMPUTER NETWORKS; PROVIDING ON-LINE COMMUNICATIONS LINKS WHICH TRANSFER THE WEB SITE USER TO OTHER LOCAL AND GLOBAL WEB PAGES; TRANSMISSION OF NEWS; VIDEO BROADCASTING SERVICES OVER THE INTERNET OR OTHER COMMUNICATIONS NETWORK FEATURING THE UPLOADED, POSTED AND TAGGED VIDEOS OF OTHERS; VIDEO BROADCASTING SERVICES OVER THE INTERNET OR OTHER COMMUNICATIONS NETWORK, NAMELY, SHOWING, DISPLAYING, AND ELECTRONICALLY TRANSMITTING VIDEO CLIPS; VIDEO BROADCASTING SERVICES VIA THE INTERNET (U.S. CLS. 100, 101 AND 104).

FIRST USE 10-10-2009; IN COMMERCE 10-10-2009.

CLASS 41—EDUCATION AND ENTERTAINMENT

FOR PROVIDING AN INTERNET NEWS PORTAL FEATURING LINKS TO NEWS STORIES AND ARTICLES IN THE FIELD OF CURRENT EVENTS; PROVIDING CURRENT EVENT NEWS AND INFORMATION VIA A GLOBAL COMPUTER NETWORK; ENTERTAINMENT, NAMELY, A CONTINUING NEWS SHOW BROADCAST OVER THE INTERNET; PROVIDING INFORMATION, NEWS AND COMMENTARY IN THE FIELD OF ENTERTAINMENT; PROVIDING NEWS AND INFORMATION IN THE FIELD OF SPORTS; PROVIDING NEWS IN THE NATURE OF CURRENT EVENT REPORTING (U.S. CLS. 100, 101 AND 107).

FIRST USE 10-10-2009; IN COMMERCE 10-10-2009.

4,016,421. ALLIED BUILDING PRODUCTS CORPORATION, EAST RUTHERFORD, NJ. SN 77-860,351. PUB. 5-25-2010, FILED 10-29-2009.

TRI-BUILT MATERIALS GROUP

THE MARK CONSISTS OF STANDARD CHARACTERS WITHOUT CLAIM TO ANY PARTICULAR FONT, STYLE, SIZE, OR COLOR.

OWNER OF U.S. REG. NOS. 2,990,094, 3,245,764, AND OTHERS.

NO CLAIM IS MADE TO THE EXCLUSIVE RIGHT TO USE "MATERIALS GROUP", APART FROM THE MARK AS SHOWN.

CLASS 1—CHEMICALS

FOR ROOFING ADHESIVE (U.S. CLS. 1, 5, 6, 10, 26 AND 46).

FIRST USE 9-1-2010; IN COMMERCE 9-1-2010.

CLASS 17—RUBBER GOODS

FOR ADHESIVE ROOFING TAPE; ROOFING CAULK, NAMELY, WEATHER-STRIPPING SEALANTS IN THE NATURE OF CAULK (U.S. CLS. 1, 5, 12, 13, 35 AND 50).

FIRST USE 9-1-2010; IN COMMERCE 9-1-2010.

CLASS 19—NON-METALLIC BUILDING MATERIALS

FOR RESIDENTIAL AND COMMERCIAL NON-METALLIC RESIDENTIAL AND COMMERCIAL BUILDING MATERIALS, NAMELY, ASPHALT ROOF COATINGS, ASPHALT ROOFING PAPER, ASPHALT SEALANT, ASPHALTED FELTS, BITUMEN-BASED SEALANTS FOR ROOFING, BITUMINOUS ROOF COATINGS, FELT ROOF COVERINGS, FIBERBOARD, ROOFING, ROOFING CEMENT, SLIDING DOORS, NON-METAL ROOF RIDGE VENTS, NON METAL WINDOWS, FIBERED AND NON-FIBERED ALUMINUM ROOF COATINGS, FIBERED AND NON-FIBERED BITUMEN ROOF COATINGS, FIBERED AND NON-FIBERED MODIFIED BITUMEN ROOF COATINGS, ASPHALTED PRIMER FOR ROOFING, FLASHING CEMENT FOR USE IN ROOFING, PLASTIC ROOFING CEMENT, BITUMEN-BASED ROOFING SEALANTS, MODIFIED BITUMEN ROLL ROOFING, ROOFING UNDERLAYMENT (U.S. CLS. 1, 12, 33 AND 50).

FIRST USE 9-1-2010; IN COMMERCE 9-1-2010.

CLASS 36—INSURANCE AND FINANCIAL

FOR APPRAISAL AND EVALUATION OF REAL ESTATE; APPRAISAL OF REAL ESTATE; FINANCIAL CONSULTING IN THE FIELD OF REAL ESTATE NOTE BROKERAGE; FINANCIAL DUE DILIGENCE SERVICES IN THE FIELD OF REAL ESTATE; FINANCIAL SERVICES, NAMELY, REAL ESTATE NOTE BROKERAGE; MORTGAGE BROKERAGE; MORTGAGE COMPLIANCE CONSULTING SERVICES CONCERNING FINANCIAL REQUIREMENTS FOR MORTGAGES FOR MORTGAGE LENDERS AND SERVICERS AND MORTGAGE BROKERS; MORTGAGE LENDING; MORTGAGE PROCUREMENT FOR OTHERS; MORTGAGE SERVICES, NAMELY, BUYER PRE-QUALIFICATION OF MORTGAGES FOR MORTGAGE BROKERS AND BANKS; REAL ESTATE APPRAISAL; REAL ESTATE APPRAISAL AND VALUATION; REAL ESTATE BROKERAGE; REAL ESTATE FINANCING SERVICES; REAL ESTATE LENDING SERVICES (U.S. CLS. 100, 101 AND 102).

FIRST USE 9-21-2009; IN COMMERCE 9-21-2009.

CLASS 45—PERSONAL AND LEGAL SERVICES

FOR REAL ESTATE CLOSING SERVICES (U.S. CLS. 100 AND 101).

FIRST USE 9-21-2009; IN COMMERCE 9-21-2009.

4,016,422. SHAPELL MORTGAGE, INC., BEVERLY HILLS, CA. SN 77-860,902. PUB. 10-19-2010, FILED 10-29-2009.



NO CLAIM IS MADE TO THE EXCLUSIVE RIGHT TO USE "MORTGAGE", APART FROM THE MARK AS SHOWN.

THE MARK CONSISTS OF A RECTANGLE DESIGN WITH A STYLIZED LETTER "S" WITH THE WORDS "SHAPELL MORTGAGE" APPEARING UNDERNEATH.

CLASS 35—ADVERTISING AND BUSINESS

FOR MATCHING BORROWERS WITH POTENTIAL LENDERS IN THE FIELD OF CONSUMER AND MORTGAGE LENDING; MATCHING BORROWERS WITH POTENTIAL LENDERS IN THE FIELD OF MORTGAGE LENDING; PROVIDING STATISTICAL INFORMATION AND INDEXES OF MORTGAGES, INTERESTS, AND PRICES FOR OTHERS (U.S. CLS. 100, 101 AND 102).

FIRST USE 9-21-2009; IN COMMERCE 9-21-2009.

4,016,424. CENTA ANTRIEBE KIRSCHHEY GMBH, HAAN, FED REP GERMANY. SN 77-862,551. PUB. 4-13-2010, FILED 11-2-2009.

CF-KE

THE MARK CONSISTS OF STANDARD CHARACTERS WITHOUT CLAIM TO ANY PARTICULAR FONT, STYLE, SIZE, OR COLOR.

OWNER OF U.S. REG. NO. 2,716,366.

CLASS 7—MACHINERY

FOR MACHINE PARTS, AND PARTS FOR AIR AND WATER VEHICLES, NAMELY, SHIFTABLE AND NON-SHIFTABLE CLUTCHES AND TRANSMISSIONS, SHAFT COUPLINGS, CLAMPING SETS AND THEIR ELEMENTS, NAMELY, KEYS, CONES, BOLTS, PINS, SPLINES AND THREADED BOLTS FOR CONNECTION OF SHAFTS WITH HUB BODIES AND PARTS FOR ALL THE FOREGOING (U.S. CLS. 13, 19, 21, 23, 31, 34 AND 35).

FIRST USE 5-10-2010; IN COMMERCE 5-10-2010.

CLASS 12—VEHICLES

FOR PARTS FOR LAND VEHICLES, NAMELY, SHIFTABLE, AND NON-SHIFTABLE CLUTCHES AND TRANSMISSIONS, SHAFT COUPLINGS, CLAMPING SETS AND THEIR ELEMENTS, NAMELY, KEYS, CONES, BOLTS, PINS, SPLINES AND THREADED BOLTS FOR CONNECTION OF SHAFTS WITH HUB BODIES AND PARTS FOR ALL THE FOREGOING (U.S. CLS. 19, 21, 23, 31, 35 AND 44).

FIRST USE 7-28-2005; IN COMMERCE 7-28-2005.

4,016,427. CONAGRA FOODS RDM, INC., OMAHA, NE. SN
77-865,622. PUB. 7-27-2010, FILED 11-5-2009.



OWNER OF U.S. REG. NO. 2,889,507.
NO CLAIM IS MADE TO THE EXCLUSIVE RIGHT TO USE "FOODS", APART FROM THE MARK AS SHOWN.
THE MARK CONSISTS OF THE WORDING "CONAGRA FOODS" ABOVE THE WORDING "FOOD YOU LOVE". A DESIGN OF A BOWL WITH A SPOON INSIDE OF IT APPEARS TO THE LEFT OF THE WORDING "FOODS".

CLASS 16—PAPER GOODS AND PRINTED MATTER

FOR NOTEPADS; PORTFOLIO FOLDERS; BLANK JOURNALS (U.S. CLS. 2, 5, 22, 23, 29, 37, 38 AND 50).
FIRST USE 6-1-2009; IN COMMERCE 6-1-2009.

CLASS 18—LEATHER GOODS

FOR CANVAS SHOPPING BAG; SHOPPING TOTE BAGS; BACKPACK; BRIEFCASE (U.S. CLS. 1, 2, 3, 22 AND 41).
FIRST USE 6-1-2009; IN COMMERCE 6-1-2009.

CLASS 21—HOUSEWARES AND GLASS

FOR PLASTIC WATER BOTTLES SOLD EMPTY; TUMBLERS FOR HOLDING BEVERAGES (U.S. CLS. 2, 13, 23, 29, 30, 33, 40 AND 50).
FIRST USE 6-1-2009; IN COMMERCE 6-1-2009.

CLASS 25—CLOTHING

FOR SHIRTS (U.S. CLS. 22 AND 39).
FIRST USE 6-1-2009; IN COMMERCE 6-1-2009.

CLASS 29—MEATS AND PROCESSED FOODS

FOR EDIBLE OILS; COOKING OILS; OIL-BASED NON-STICK COOKING SPRAY; FROZEN POTATO PRODUCTS, NAMELY, FRENCH FRIES, POTATO WEDGES; PROCESSED POTATOES; VEGETABLE-BASED SNACK FOODS AND APPETIZERS CONSISTING PRIMARILY OF PROCESSED VEGETABLES; FROZEN, PREPARED OR PACKAGED MEALS CONSISTING PRIMARILY OF MEAT, SEAFOOD, POULTRY OR VEGETABLES; PACKAGED MEAL KITS COMPOSED OF MEAT, SEAFOOD, POULTRY AND/OR VEGETABLES AND ALSO INCLUDING SAUCES AND SEASONINGS; FROZEN CHICKEN PRODUCTS, NAMELY, FROZEN PREPARED CHICKEN, FRIED CHICKEN, POPCORN CHICKEN, CHICKEN PATTIES, CHICKEN NUGGETS, CHICKEN STRIPS, CHICKEN WINGS, CHICKEN BREASTS; BREAKFAST SAUSAGE, SAUSAGE PATTIES; SOUPS; MARGARINES AND VEGETABLE-BASED SPREADS; PROCESSED EDIBLE SUNFLOWER SEEDS, PROCESSED EDIBLE SUNFLOWER SEED KERNELS AND PROCESSED EDIBLE PUMPKIN SEEDS; CHILI WITH OR WITHOUT BEANS WITH MEAT AND CHILI WITH OR WITHOUT BEANS WITHOUT MEAT; LIQUID EGGS; FROZEN EGGS; OMELETS; BEEF FRANKFURTERS, DELI MEATS, COLD CUTS, NAMELY, TURKEY, HAM, CHICKEN; SAUSAGES, KNOCKWURST; SAUERKRAUT; PROCESSED TOMATOES, TOMATO PASTE, TOMATO PRODUCTS, NAMELY, PEELED TOMATOES, DICED TOMATOES, CANNED WHOLE TOMATOES; PROCESSED VEGETABLES; MEAT SUBSTITUTES; PEANUT BUTTER; REAL DAIRY WHIPPED CREAM; PACKAGED MEAT-BASED SNACKS; DESSERT TOPPINGS, NAMELY, WHIPPED CREAM AND PREPARED NUTS; FRUIT-BASED SNACKS; PICKLED SAUSAGES AND EGGS; CORN DOGS; DESSERT TOPPINGS, NAMELY, FRUIT-BASED TOPPINGS (U.S. CL. 46).
FIRST USE 11-1-2009; IN COMMERCE 11-1-2009.

CLASS 30—STAPLE FOODS

FOR MICROWAVE POPCORN, POPPED POPCORN, UNPOPPED POPCORN; READY-TO-EAT POPCORN; SNACK MIX CONSISTING PRIMARILY OF POPPED POPCORN AND ALSO CONTAINING PROCESSED NUTS; FROZEN BREADS; BREAD; FROZEN, PREPARED OR PACKAGED MEALS CONSISTING PRIMARILY OF PASTA OR RICE; PACKAGED MEAL KITS COMPOSED OF PASTA OR RICE AND ALSO INCLUDING SAUCES AND SEASONINGS; POT PIES; BURRITOS; FROZEN CONFECTIONS; SHELF-STABLE PASTA AND SAUCES; KITS COMPRISED OF INGREDIENTS FOR PREPARING PIZZA; MUSTARD; DOUGH-ENROBED BEEF FRANKFURTER SANDWICHES; TOMATO SAUCE; PASTA SAUCE; KETCHUP AND BARBECUE SAUCE; CHILI SAUCE; SALSA; ENCHILADA SAUCE; FROZEN APPETIZERS, NAMELY, EGG ROLLS, POT STICKERS; RICE NOODLES; CHOW MEIN NOODLES; FORTUNE COOKIES; SAUCES, NAMELY, CHINESE SAUCES; SOY SAUCE; SLOPPY JOE SAUCE; FROZEN MEXICAN-STYLE MEALS PRIMARILY CONSISTING OF BURRITOS, ENCHILADAS AND CHIMICHANGAS AND ALSO CONTAINING MEAT, CHICKEN, VEGETABLES AND CHEESE; NACHO CHEESE SAUCE; HOT COCOA MIX; PUDDING; GEL SNACKS, NAMELY, FLAVORED AND SWEETENED GELATIN; FROZEN FILLED PASTA AND PIZZA SAUCES; LASAGNA; BLINTZES, CREPES; FLOUR; PROCESSED GRAINS; CHILI POWDERS; CHILI SEASONING; DOUGH-ENROBED BREAKFAST SANDWICHES; FROZEN PIZZA; STUFFED SANDWICHES; FROZEN HAND-HELD BAKERY DESSERTS WITH FRUIT FILLING; DESSERT TOPPINGS, NAMELY, CHOCOLATE SYRUP, BASES FOR MAKING MILKSHAKES; FRUIT SAUCES EXCLUDING CRANBERRY SAUCE AND APPLESAUCE; FRENCH TOAST, PANCAKES; DOUGH-ENROBED WRAPPER WITH FILLING CONSISTING PRIMARILY OF CHEESE; FRUIT-BASED SNACK FOOD, NAMELY, DOUGH-ENROBED SNACK FOODS WITH FILLINGS CONSISTING PRIMARILY OF FRUIT (U.S. CL. 46).
FIRST USE 8-1-2009; IN COMMERCE 8-1-2009.

CLASS 31—NATURAL AGRICULTURAL PRODUCTS

FOR UNPROCESSED GRAINS (U.S. CLS. 1 AND 46).
FIRST USE 2-1-2010; IN COMMERCE 2-1-2010.

CLASS 32—LIGHT BEVERAGES

FOR SYRUPS FOR BEVERAGES; FOUNTAIN SYRUPS FOR MAKING BEVERAGES (U.S. CLS. 45, 46 AND 48). FIRST USE 1-1-2010; IN COMMERCE 1-1-2010.

4,016,428. CAREERARC GROUP LLC, BURBANK, CA. SN 77-866,091. PUB. 11-23-2010, FILED 11-5-2009.



THE MARK CONSISTS OF A LOWERCASE LETTER "I" INCORPORATING THE DESIGN OF A DOOR AND WITHIN A SHADED BOX.

CLASS 35—ADVERTISING AND BUSINESS

FOR PROVIDING JOB PLACEMENT AND INTERNSHIP PLACEMENT AND RECRUITING SERVICES; PROVIDING CAREER INFORMATION; ONLINE COMPUTERIZED DATABASE FEATURING INFORMATION THAT ALLOWS ORGANIZATIONS TO EVALUATE AND GENERATE REPORTS REGARDING THE EFFECTIVENESS OF JOB TRAINING AND EMPLOYEE DEVELOPMENT AS IT RELATES TO EMPLOYEE PERFORMANCE AND WORKPLACE LEARNING; EMPLOYMENT COUNSELING AND RECRUITING; CAREER PLACEMENT, NETWORKING, DEVELOPMENT, AND MANAGEMENT SERVICES; AN ONLINE SEARCHABLE DATABASE FEATURING EMPLOYMENT OPPORTUNITIES, POTENTIAL EMPLOYERS, AND JOB CANDIDATES; ARRANGING AND COORDINATING INTERNSHIP AND APPRENTICESHIP OPPORTUNITIES FOR OTHERS (U.S. CLS. 100, 101 AND 102). FIRST USE 2-16-2010; IN COMMERCE 2-16-2010.

CLASS 38—COMMUNICATION

FOR PROVIDING ON-LINE CHAT ROOMS AND ELECTRONIC BULLETIN BOARDS FOR SOCIAL NETWORKING AND FOR TRANSMISSION OF MESSAGES AMONG USERS CONCERNING INTERNSHIPS, CAREER PLACEMENT, DEVELOPMENT, INFORMATION AND COUNSELING; TELECOMMUNICATION SERVICES, NAMELY, TRANSMISSION OF VOICE, DATA, GRAPHICS, IMAGES, AUDIO AND VIDEO BY MEANS OF TELECOMMUNICATIONS NETWORKS, WIRELESS COMMUNICATION NETWORKS, AND THE INTERNET (U.S. CLS. 100, 101 AND 104). FIRST USE 12-2-2010; IN COMMERCE 12-2-2010.

CLASS 41—EDUCATION AND ENTERTAINMENT

FOR EDUCATIONAL SERVICES, NAMELY, PROVIDING EMPLOYMENT DEVELOPMENT SKILLS AND JOB TRAINING CLASSES; EDUCATIONAL SERVICES, NAMELY, PROVIDING COURSES OF INSTRUCTION AND SEMINARS IN THE FIELD OF HOW TO EXPAND CAREER OPPORTUNITIES VIA CAREER DEVELOPMENT ACTIVITIES AND INTERNSHIPS; PROVIDING ONLINE JOB TRAINING, SEMINARS AND WORKSHOPS IN THE FIELD OF PROFESSIONAL DEVELOPMENT; CAREER COUNSELING; PROVIDING ON-LINE NEWSLETTERS IN THE FIELDS OF CAREER DEVELOPMENT AND COUNSELING (U.S. CLS. 100, 101 AND 107). FIRST USE 2-16-2010; IN COMMERCE 2-16-2010.

CLASS 42—SCIENTIFIC AND COMPUTER SERVICES

FOR COMPUTER SERVICES, NAMELY, PROVIDING NON-DOWNLOADABLE SOFTWARE FOR INTERNSHIP PROGRAM MANAGEMENT, CAREER PLACEMENT, CAREER DEVELOPMENT, CAREER COUNSELING; DEVELOPING, DESIGNING, AND IMPLEMENTING OF NETWORK WEB PAGES OF OTHERS FEATURING RESUME AND INTERNSHIP AND EMPLOYMENT APPLICATION CREATION (U.S. CLS. 100 AND 101). FIRST USE 2-16-2010; IN COMMERCE 2-16-2010.

4,016,429. CAREERARC GROUP LLC, BURBANK, CA. SN 77-866,109. PUB. 11-23-2010, FILED 11-5-2009.

HIRED EDUCATION

THE MARK CONSISTS OF STANDARD CHARACTERS WITHOUT CLAIM TO ANY PARTICULAR FONT, STYLE, SIZE, OR COLOR.

CLASS 35—ADVERTISING AND BUSINESS

FOR PROVIDING JOB PLACEMENT AND INTERNSHIP PLACEMENT AND RECRUITING SERVICES; PROVIDING CAREER INFORMATION; ONLINE COMPUTERIZED DATABASE FEATURING INFORMATION THAT ALLOWS ORGANIZATIONS TO EVALUATE AND GENERATE REPORTS REGARDING THE EFFECTIVENESS OF JOB TRAINING AND EMPLOYEE DEVELOPMENT AS IT RELATES TO EMPLOYEE PERFORMANCE AND WORKPLACE LEARNING; EMPLOYMENT COUNSELING AND RECRUITING; CAREER PLACEMENT, NETWORKING, DEVELOPMENT, AND MANAGEMENT SERVICES; AN ONLINE SEARCHABLE DATABASE FEATURING EMPLOYMENT OPPORTUNITIES, POTENTIAL EMPLOYERS, AND JOB CANDIDATES; ARRANGING AND COORDINATING INTERNSHIP AND APPRENTICESHIP OPPORTUNITIES FOR OTHERS (U.S. CLS. 100, 101 AND 102). FIRST USE 2-16-2010; IN COMMERCE 2-16-2010.

CLASS 38—COMMUNICATION

FOR PROVIDING ON-LINE CHAT ROOMS AND ELECTRONIC BULLETIN BOARDS FOR SOCIAL NETWORKING AND FOR TRANSMISSION OF MESSAGES AMONG USERS CONCERNING INTERNSHIPS, CAREER PLACEMENT, DEVELOPMENT, INFORMATION AND COUNSELING; TELECOMMUNICATION SERVICES, NAMELY, TRANSMISSION OF VOICE, DATA, GRAPHICS, IMAGES, AUDIO AND VIDEO BY MEANS OF TELECOMMUNICATIONS NETWORKS, WIRELESS COMMUNICATION NETWORKS, AND THE INTERNET (U.S. CLS. 100, 101 AND 104).

FIRST USE 12-2-2010; IN COMMERCE 12-2-2010.

CLASS 41—EDUCATION AND ENTERTAINMENT

FOR EDUCATIONAL SERVICES, NAMELY, PROVIDING EMPLOYMENT DEVELOPMENT SKILLS AND JOB TRAINING CLASSES; EDUCATIONAL SERVICES, NAMELY, PROVIDING COURSES OF INSTRUCTION AND SEMINARS IN THE FIELD OF HOW TO EXPAND CAREER OPPORTUNITIES VIA CAREER DEVELOPMENT ACTIVITIES AND INTERNSHIPS; PROVIDING ONLINE JOB TRAINING, SEMINARS AND WORKSHOPS IN THE FIELD OF PROFESSIONAL DEVELOPMENT; CAREER COUNSELING; PROVIDING ON-LINE NEWSLETTERS IN THE FIELDS OF CAREER DEVELOPMENT AND COUNSELING (U.S. CLS. 100, 101 AND 107).

FIRST USE 2-16-2010; IN COMMERCE 2-16-2010.

CLASS 42—SCIENTIFIC AND COMPUTER SERVICES

FOR COMPUTER SERVICES, NAMELY, PROVIDING NON-DOWNLOADABLE SOFTWARE FOR INTERNSHIP PROGRAM MANAGEMENT, CAREER PLACEMENT, CAREER DEVELOPMENT, CAREER COUNSELING; DEVELOPING, DESIGNING, AND IMPLEMENTING OF NETWORK WEB PAGES OF OTHERS FEATURING RESUME AND INTERNSHIP AND EMPLOYMENT APPLICATION CREATION (U.S. CLS. 100 AND 101).

FIRST USE 2-16-2010; IN COMMERCE 2-16-2010.

4,016,433. SPOKE MEDIA HOLDINGS, INC., SAN DIEGO, CA. SN 77-868,729. PUB. 11-23-2010, FILED 11-9-2009.

C3 METRICS

THE MARK CONSISTS OF STANDARD CHARACTERS WITHOUT CLAIM TO ANY PARTICULAR FONT, STYLE, SIZE, OR COLOR.

NO CLAIM IS MADE TO THE EXCLUSIVE RIGHT TO USE "METRICS", APART FROM THE MARK AS SHOWN.

CLASS 9—ELECTRICAL AND SCIENTIFIC APPARATUS

FOR COMPUTER PROGRAMS FOR TRACKING AND ANALYZING ONLINE TRAFFIC RELATED TO (1) USERS CLICKING THROUGH TO ONLINE ADVERTISEMENTS AND WEBSITES, (2) USERS VIEWING ONLINE ADVERTISEMENTS AND WEBSITES, (3) MANAGEMENT OF AND OPTIMIZATION OF EXPENDITURES AND RETURNS RELATED TO THE AFORESAID ONLINE TRAFFIC, AND (4) VERIFYING AND CREDITING SOURCES OF THE AFORESAID ONLINE TRAFFIC (U.S. CLS. 21, 23, 26, 36 AND 38).

FIRST USE 6-9-2008; IN COMMERCE 2-16-2009.

CLASS 35—ADVERTISING AND BUSINESS

FOR BUSINESS MANAGEMENT AND ADVISORY SERVICES RELATED TO (1) ONLINE TRAFFIC RELATED TO USERS CLICKING THROUGH TO ONLINE ADVERTISEMENTS AND WEBSITES, (2) USERS VIEWING ONLINE ADVERTISEMENTS AND WEBSITES, (3) MANAGEMENT OF AND OPTIMIZATION OF EXPENDITURES AND RETURNS RELATED TO THE AFORESAID ONLINE TRAFFIC (4) PLANNING AND MANAGEMENT SERVICES RELATED TO OPTIMIZATION OF ONLINE ADVERTISING AND ONLINE MARKETING, (5) ACCOUNTING SERVICES, NAMELY, VERIFYING AND CREDITING SOURCES OF THE AFORESAID ONLINE TRAFFIC, AND (6) PROVIDING BOOKKEEPING SERVICES FOR OTHERS IN THE FIELD OF ADVERTISING, NAMELY, KEEPING TRACK OF MONETARY EXPENDITURES AND RETURNS RELATED TO CLICK-THRU TRAFFIC AND VIEW-BASED IMPRESSIONS (U.S. CLS. 100, 101 AND 102).

FIRST USE 2-16-2009; IN COMMERCE 2-16-2009.

CLASS 42—SCIENTIFIC AND COMPUTER SERVICES

FOR PROVIDING COMPUTER SYSTEMS AND SERVICES AND HOSTING APPLICATIONS, NAMELY, APPLICATION SERVICE PROVIDER (ASP) SERVICES FEATURING SOFTWARE FOR TRACKING AND ANALYZING ONLINE TRAFFIC RELATED TO (1) USERS CLICKING THROUGH TO ONLINE ADVERTISEMENTS AND WEBSITES, (2) USERS VIEWING ONLINE ADVERTISEMENTS AND WEBSITES, (3) MANAGEMENT OF AND OPTIMIZATION OF EXPENDITURES AND RETURNS RELATED TO THE AFORESAID ONLINE TRAFFIC, AND (4) VERIFYING AND CREDITING SOURCES OF THE AFORESAID ONLINE TRAFFIC (U.S. CLS. 100 AND 101).

FIRST USE 2-16-2009; IN COMMERCE 2-16-2009.

4,016,443. MORRISON MANAGEMENT SPECIALISTS, INC., ATLANTA, GA. SN 77-876,078. PUB. 9-7-2010, FILED 11-19-2009.

ELIVING

THE MARK CONSISTS OF STANDARD CHARACTERS WITHOUT CLAIM TO ANY PARTICULAR FONT, STYLE, SIZE, OR COLOR.

CLASS 35—ADVERTISING AND BUSINESS

FOR ONLINE RETAIL STORE SERVICES IN THE FIELD OF FOOD (U.S. CLS. 100, 101 AND 102).

FIRST USE 6-3-2011; IN COMMERCE 6-3-2011.

CLASS 44—MEDICAL, BEAUTY AND AGRICULTURAL SERVICES

FOR PROVIDING AN INTERACTIVE WEBSITE FEATURING INFORMATION ABOUT HEALTH, NUTRITION, WELLNESS, MEDICAL CONDITIONS, AND FOOD, DRUG, AND ALLERGEN INTERACTION; PROVIDING AN INTERACTIVE WEBSITE FEATURING DIETARY AND NUTRITIONAL GUIDANCE, NAMELY, CUSTOMIZED MEAL PLANS AND DIETS BASED ON USER-DEFINED AND DEMOGRAPHIC INFORMATION; PROVIDING AN INTERACTIVE WEBSITE FEATURING CUSTOMIZED INFORMATION ABOUT HEALTH, NUTRITION, WELLNESS, MEDICAL CONDITIONS, AND FOOD, DRUG, AND ALLERGEN INTERACTION, BASED ON USER-DEFINED AND DEMOGRAPHIC INFORMATION; NUTRITIONAL COUNSELING, SERVICES RENDERED BY A DIETITIAN; COUNSELING SERVICES IN THE FIELDS OF HEALTH, NUTRITION AND LIFESTYLE WELLNESS (U.S. CLS. 100 AND 101).
FIRST USE 6-3-2011; IN COMMERCE 6-3-2011.

4,016,448. LSR PERFORMANCE, LLC, POMPANO BEACH, FL. SN 77-877,672. PUB. 11-23-2010, FILED 11-20-2009.

LSR Performance

THE MARK CONSISTS OF STANDARD CHARACTERS WITHOUT CLAIM TO ANY PARTICULAR FONT, STYLE, SIZE, OR COLOR.

NO CLAIM IS MADE TO THE EXCLUSIVE RIGHT TO USE "PERFORMANCE", APART FROM THE MARK AS SHOWN.

CLASS 12—VEHICLES

FOR AUTOMOBILES AND PARTS THEREFOR, NAMELY, AUTOMOTIVE DRIVE TRAIN PARTS, NAMELY, DRIVE SHAFTS, GEAR SHIFTER BUSHINGS, SHIFT KNOBS, CLUTCH QUADRANTS, CLUTCH CABLES, TRANSMISSIONS, CLUTCHES, AND RING PINION GEARS; AUTOMOTIVE BRAKE PARTS, NAMELY, DISC BRAKE KITS COMPOSED OF CALIPERS, PISTONS, PADS, MASTER CYLINDER, AND BRAKE FLUID; CONVERSION KITS COMPOSED OF MASTER CYLINDER, AXLE HALF SHAFTS, CALIPERS, ROTORS, VALVES, PADS, LINES, BRACKETS, AND HARDWARE; AUTOMOTIVE SUSPENSION PARTS, NAMELY, FRAME RAIL CONNECTORS, SPRINGS, TRACTION BARS, STRUT TOWER BRACES, SWAY BARS, BUSHINGS, STEERING BUSHINGS, CASTER-CAMBER PLATES AND CONTROL ARMS; AUTOMOTIVE WHEELS; AUTOMOTIVE SPOILERS; AUTOMOTIVE GROUND EFFECT KITS COMPOSED OF AIR DAM, SIDE SKIRTS, AND REAR VALENCE AND AUTOMOTIVE NOSEPIECES (U.S. CLS. 19, 21, 23, 31, 35 AND 44).

FIRST USE 10-1-2008; IN COMMERCE 10-1-2008.

CLASS 35—ADVERTISING AND BUSINESS

FOR RETAIL STORES FEATURING AUTOMOBILES AND AUTOMOTIVE PARTS; MAIL ORDER CATALOG SERVICES FEATURING AUTOMOBILES AND AUTOMOTIVE PARTS; AND DISTRIBUTORSHIP SERVICES IN THE FIELD OF AUTOMOBILES AND AUTOMOTIVE PARTS, EXPRESSLY EXCLUDING VEHICLE TIRES AND INNERTUBES FOR VEHICLE TIRES AND SOLID RUBBER TIRES AND TIRE RIMS (U.S. CLS. 100, 101 AND 102).

FIRST USE 10-1-2008; IN COMMERCE 10-1-2008.

4,016,446. LSR PERFORMANCE, LLC, POMPANO BEACH, FL. SN 77-877,536. PUB. 11-2-2010, FILED 11-20-2009.

MPR Performance

THE MARK CONSISTS OF STANDARD CHARACTERS WITHOUT CLAIM TO ANY PARTICULAR FONT, STYLE, SIZE, OR COLOR.

NO CLAIM IS MADE TO THE EXCLUSIVE RIGHT TO USE "PERFORMANCE", APART FROM THE MARK AS SHOWN.

CLASS 12—VEHICLES

FOR AUTOMOBILES AND PARTS THEREFOR, NAMELY, AUTOMOTIVE DRIVE TRAIN PARTS, NAMELY, DRIVE SHAFTS, GEAR SHIFTER BUSHINGS, SHIFT KNOBS, CLUTCH QUADRANTS, CLUTCH CABLES, TRANSMISSIONS, CLUTCHES, AND RING AND PINION GEARS; AUTOMOTIVE BRAKE PARTS, NAMELY, DISC BRAKE KITS COMPOSED OF CALIPERS, PISTONS, PADS, MASTER CYLINDER, AND BRAKE FLUID; CONVERSION KITS COMPOSED OF MASTER CYLINDER, AXLE HALF SHAFTS, CALIPERS, ROTORS, VALVES, PADS, LINES, BRACKETS, AND HARDWARE; AUTOMOTIVE SUSPENSION PARTS, NAMELY, FRAME RAIL CONNECTORS, SPRINGS, TRACTION BARS, STRUT TOWER BRACES, SWAY BARS, BUSHINGS, STEERING BUSHINGS, CASTER-CAMBER PLATES AND CONTROL ARMS; AUTOMOTIVE WHEELS; AUTOMOTIVE SPOILERS; AUTOMOTIVE GROUND EFFECT KITS COMPOSED OF AIR DAM, SIDE SKIRTS, AND REAR VALENCE AND AUTOMOTIVE NOSEPIECES (U.S. CLS. 19, 21, 23, 31, 35 AND 44).

FIRST USE 10-1-2008; IN COMMERCE 10-1-2008.

CLASS 35—ADVERTISING AND BUSINESS

FOR RETAIL STORES AND MAIL ORDER CATALOGS IN THE FIELD OF AUTOMOBILES AND AUTOMOTIVE PRODUCTS, AND DISTRIBUTORSHIP SERVICES IN THE FIELD OF AUTOMOBILES AND AUTOMOBILE PRODUCTS (U.S. CLS. 100, 101 AND 102).
FIRST USE 10-1-2008; IN COMMERCE 10-1-2008.

4,016,449. CSM BAKERY PRODUCTS NA, INC., TUCKER, GA. SN 77-878,029. PUB. 11-30-2010, FILED 11-20-2009.

BAKESENSE

THE MARK CONSISTS OF STANDARD CHARACTERS WITHOUT CLAIM TO ANY PARTICULAR FONT, STYLE, SIZE, OR COLOR.

CLASS 16—PAPER GOODS AND PRINTED MATTER

FOR WAX PAPER FOR USE AS A PAN LINER (U.S. CLS. 2, 5, 22, 23, 29, 37, 38 AND 50).
FIRST USE 1-0-2008; IN COMMERCE 1-0-2008.

CLASS 21—HOUSEWARES AND GLASS

FOR PASTRY BOARDS FOR CAKES; PASTRY BAGS; DECORATING BAGS FOR CONFECTIONERS (U.S. CLS. 2, 13, 23, 29, 30, 33, 40 AND 50).

FIRST USE 1-0-2008; IN COMMERCE 1-0-2008.

CLASS 29—MEATS AND PROCESSED FOODS

FOR SPRAY COOKING OIL FOR PANS; NON-DAIRY COFFEE CREAMER; PROCESSED NUTS; SWEETENED CONDENSED MILK; RAISINS; PROCESSED EDIBLE SEEDS; MARGARINE; EGG WHITES; EGG YOLKS; EGGS; FRUIT AND VEGETABLE PUREES (U.S. CL. 46).

FIRST USE 1-0-2008; IN COMMERCE 1-0-2008.

CLASS 30—STAPLE FOODS

FOR CHOCOLATE; CHOCOLATE CHIPS AND CHUNKS; SUGAR AND SPICES; BAKING SODA (U.S. CL. 46).

FIRST USE 1-0-2008; IN COMMERCE 1-0-2008.

4,016,459. EMIRATES INTEGRATED TELECOMMUNICATIONS COMPANY PJSC, DUBAI, UNITED ARAB EMIR.. SN 77-882,880. PUB. 11-2-2010, FILED 12-1-2009.



THE MARK CONSISTS OF A STYLIZED TELEVISION SCREEN ABOVE THE WORDS "ANAYOU".

CLASS 38—COMMUNICATION

FOR TELECOMMUNICATIONS AND COMMUNICATIONS SERVICES, NAMELY, PROVIDING ONLINE FACILITIES FOR REAL-TIME INTERACTION WITH OTHER COMPUTER USERS CONCERNING TOPICS OF GENERAL INTEREST; ELECTRONIC MAIL AND INSTANT MESSAGING SERVICES ON THE INTERNET; WEB MESSAGING AND TEXT MESSAGING SERVICES; BROADCASTING PROGRAMS VIA A GLOBAL COMPUTER NETWORK; INTERNET BROADCASTING SERVICES; WEBCASTING SERVICES; TRANSMISSION OF MESSAGES, DATA AND CONTENT VIA A GLOBAL COMPUTER NETWORK AND OTHER COMPUTER AND COMMUNICATIONS NETWORKS; NEWS AGENCY SERVICES FOR ELECTRONIC TRANSMISSION; LEASING OR RENTAL OF COMMUNICATIONS APPARATUS; PROVIDING ONLINE FORUMS, CHAT ROOMS FOR THE TRANSMISSION OF MESSAGES, AND MULTIMEDIA CONTENT AMONG USERS IN THE FIELD OF SOCIAL NETWORKING AND GENERAL INTEREST (U.S. CLS. 100, 101 AND 104).

FIRST USE 12-31-2010; IN COMMERCE 12-31-2010.

CLASS 45—PERSONAL AND LEGAL SERVICES

FOR SECURITY SERVICES FOR THE PROTECTION OF PROPERTY AND INDIVIDUALS; INTERNET SOCIAL INTRODUCTION AND SOCIAL NETWORKING SERVICES (U.S. CLS. 100 AND 101).

FIRST USE 12-31-2010; IN COMMERCE 12-31-2010.

4,016,450. JOHNSON & JOHNSON, NEW BRUNSWICK, NJ. SN 77-878,430. PUB. 11-2-2010, FILED 11-23-2009.

PARTNERS IN PRACTICE

THE MARK CONSISTS OF STANDARD CHARACTERS WITHOUT CLAIM TO ANY PARTICULAR FONT, STYLE, SIZE, OR COLOR.

CLASS 35—ADVERTISING AND BUSINESS

FOR ONLINE OFFICE MANAGEMENT SERVICES PROVIDED TO EYE CARE PROFESSIONALS FOR STREAMLINING PATIENT CARE AND VISITS THROUGH PROVIDING PATIENT REMINDER SERVICES REGARDING APPOINTMENT SCHEDULING AND CONFIRMATION AND WHEN TO CHANGE AND PURCHASE NEW CONTACT LENSES; OFFERING THE SERVICE OF REFERRING EYE CARE PROFESSIONALS TO PROSPECTIVE PATIENTS (U.S. CLS. 100, 101 AND 102).

FIRST USE 4-0-2010; IN COMMERCE 4-0-2010.

CLASS 41—EDUCATION AND ENTERTAINMENT

FOR EDUCATIONAL SERVICES, NAMELY, PROVIDING AN ONLINE TRAINING PROGRAM FOR EYE CARE PROFESSIONALS AND THEIR STAFF TO ACCELERATE EFFICIENCIES IN THE DELIVERY OF CONTACT LENS SERVICES AND TO ENHANCE PATIENT AND STAFF SATISFACTION (U.S. CLS. 100, 101 AND 107).

FIRST USE 4-0-2010; IN COMMERCE 4-0-2010.

4,016,460. MOBI MUNCH, INC., CARSON CITY, NV. SN 77-882,962. PUB. 11-9-2010, FILED 12-1-2009.

MOBI MUNCH

THE MARK CONSISTS OF STANDARD CHARACTERS WITHOUT CLAIM TO ANY PARTICULAR FONT, STYLE, SIZE, OR COLOR.

CLASS 35—ADVERTISING AND BUSINESS

FOR ADVERTISING AND BUSINESS MANAGEMENT CONSULTANCY; ADVERTISING, MARKETING AND PROMOTION SERVICES; BUSINESS CONSULTING AND INFORMATION SERVICES; BUSINESS MANAGEMENT CONSULTING; MOBILE FOOD KIOSK SERVICES; MOBILE STREET VENDOR SERVICES FEATURING FOOD AND DRINK; ON-LINE ADVERTISING AND MARKETING SERVICES; ON-LINE BUSINESS DIRECTORIES FEATURING MOBILE FOOD STREET VENDORS; PROVIDING ON-LINE CONSUMER INFORMATION CONCERNING THE LOCATION OF MOBILE RESTAURANTS AND MOBILE FOOD STREET VENDORS; REFERRALS IN THE FIELD OF RESTAURANTS (U.S. CLS. 100, 101 AND 102).

FIRST USE 3-0-2011; IN COMMERCE 3-0-2011.

CLASS 39—TRANSPORTATION AND STORAGE

FOR LEASING OF MOBILE FOOD KIOSK VEHICLE (U.S. CLS. 100 AND 105).

FIRST USE 3-0-2011; IN COMMERCE 3-0-2011.

CLASS 42—SCIENTIFIC AND COMPUTER SERVICES

FOR PROVIDING, NAMELY, HOSTING AN ONLINE COMMUNITY FOR USERS TO SHARE INFORMATION, PHOTOS, AUDIO AND VIDEO CONTENT ABOUT THEMSELVES, THEIR LIKES AND DISLIKES AND DAILY ACTIVITIES, TO GET FEEDBACK FROM THEIR PEERS, TO FORM VIRTUAL COMMUNITIES (U.S. CLS. 100 AND 101).

FIRST USE 3-0-2011; IN COMMERCE 3-0-2011.

CLASS 43—HOTEL AND RESTAURANT SERVICES

FOR PROVIDING REVIEWS OF RESTAURANTS; PROVIDING REVIEWS OF MOBILE FOOD STREET VENDORS; PROVIDING INFORMATION ABOUT RESTAURANT SERVICES, NAMELY, COMPILATIONS OF INFORMATION COLLECTED BY OTHERS, RANKINGS, REVIEWS AND RECOMMENDATIONS RELATING TO RESTAURANTS FOR FOOD AND BEVERAGE APPRECIATION PURPOSES USING A GLOBAL COMPUTER NETWORK (U.S. CLS. 100 AND 101).

FIRST USE 3-0-2011; IN COMMERCE 3-0-2011.

4,016,461. LOXCREEN CANADA LTD., MISSISSAUGA, ONTARIO, CANADA. SN 77-883,615. PUB. 11-16-2010, FILED 12-1-2009.



PRIORITY CLAIMED UNDER SEC. 44(D) ON CANADA APPLICATION NO. 1445471, FILED 7-21-2009, REG. NO. TMA771365, DATED 7-6-2010, EXPIRES 7-6-2025.

THE MARK CONSISTS OF A STYLIZED FORM OF THE WORD "LOXCREEN".

CLASS 6—METAL GOODS

FOR METAL BUILDING MATERIALS, NAMELY, CORNER MOLDING; STAIR NOSING; STAIR TREADS; CARPET TAPDOWNS; TRANSITIONS FOR TILE, CARPET, HARDWOOD AND LAMINATE FLOORING; FLOOR; WALL, COUNTERTOP AND CABINET TRIM (U.S. CLS. 2, 12, 13, 14, 23, 25 AND 50).

FIRST USE 0-0-1953; IN COMMERCE 0-0-1953.

CLASS 19—NON-METALLIC BUILDING MATERIALS

FOR NON-METAL BUILDING MATERIALS, NAMELY, WALL BASE; WALL CAP; COVE MOLDING; CORNER MOLDING; STAIR NOSING; STAIR TREADS; CARPET TAPDOWNS; TRANSITIONS FOR TILE, CARPET, HARDWOOD AND LAMINATE FLOORING; FLOOR; WALL, COUNTERTOP AND CABINET TRIM (U.S. CLS. 1, 12, 33 AND 50).

FIRST USE 0-0-1953; IN COMMERCE 0-0-1953.

4,016,463. FHF FUNKE + HUSTER FERNSIG GMBH, MUELHEIM AN DER RUHR, FED REP GERMANY. SN 77-884,086. PUB. 11-2-2010, FILED 12-2-2009.

InduTel

THE MARK CONSISTS OF STANDARD CHARACTERS WITHOUT CLAIM TO ANY PARTICULAR FONT, STYLE, SIZE, OR COLOR.

CLASS 9—ELECTRICAL AND SCIENTIFIC APPARATUS

FOR APPARATUS FOR SIGNALING, NAMELY, WATER-PROOF LUMINOUS BEACONS FOR SAFETY OR WARNING PURPOSES; APPARATUS FOR RECORDING, TRANSMISSION OR REPRODUCTION OF SOUND OR IMAGES, NAMELY, MAGNETIC DATA CARRIERS, RECORDING DISCS; AUTOMATIC VENDING MACHINES AND MECHANISMS FOR COIN-OPERATED APPARATUS; CASH REGISTERS, CALCULATING MACHINES, DATA PROCESSING EQUIPMENT AND COMPUTERS; FIRE-EXTINGUISHING APPARATUS; TELEPHONE APPARATUSES, TELEPHONES, ANALOG TELEPHONES, DIGITAL TELEPHONES, DESK TELEPHONES, WALL TELEPHONES, PAGERS, INDUSTRIAL TELEPHONES AND WATER-PROOF TELEPHONES, MAINLY FOR USE OUTDOORS; TELEPHONE WIRES; MOBILE TELEPHONES; TELEPHONE RECEIVERS; TELEGRAPHY APPARATUS FOR WIRELESS TELEGRAPHY, RADIO TELEGRAPHY, SPACE TELEGRAPHY, OPTICAL TELEGRAPHY, PHOTOTELEGRAPHY, FACSIMILE TELEGRAPHY; ALL THE AFORESAID APPARATUS ALSO AND IN PARTICULAR FOR USE IN AREAS VULNERABLE TO EXPLOSIONS (U.S. CLS. 21, 23, 26, 36 AND 38).

FIRST USE 5-14-2008; IN COMMERCE 6-8-2011.

CLASS 38—COMMUNICATION

FOR TELECOMMUNICATIONS, NAMELY, ELECTRONIC MESSAGE SENDING; TELEPHONE AND TELEGRAPH COMMUNICATION SERVICES; RENTAL OF TELEPHONES AND TELECOMMUNICATIONS APPARATUS; ALL THE AFORESAID SERVICES ALSO AND IN PARTICULAR PROVIDED IN AREAS VULNERABLE TO EXPLOSIONS (U.S. CLS. 100, 101 AND 104).

FIRST USE 5-14-2008; IN COMMERCE 6-8-2011.

4,016,470. GOOGLE INC., MOUNTAIN VIEW, CA. SN 77-886,861. PUB. 10-26-2010, FILED 12-4-2009.

GOOGLE GOGGLES

THE MARK CONSISTS OF STANDARD CHARACTERS WITHOUT CLAIM TO ANY PARTICULAR FONT, STYLE, SIZE, OR COLOR.

OWNER OF U.S. REG. NOS. 2,806,075, 2,954,071, AND OTHERS.

CLASS 9—ELECTRICAL AND SCIENTIFIC APPARATUS

FOR COMPUTER SOFTWARE FOR SEARCHING AND RETRIEVING INFORMATION OVER A GLOBAL COMPUTER NETWORK, FOR LANGUAGE TRANSLATION, AND FOR VIEWING AND SHARING DIGITAL PHOTOS (U.S. CLS. 21, 23, 26, 36 AND 38).

FIRST USE 12-7-2009; IN COMMERCE 12-7-2009.

CLASS 42—SCIENTIFIC AND COMPUTER SERVICES

FOR PROVISION OF SEARCH ENGINES AVAILABLE OVER A GLOBAL COMPUTER NETWORK; ONLINE SERVICES, NAMELY, PROVISION OF NON-DOWNLOADABLE SOFTWARE FOR SEARCHING AND RETRIEVING INFORMATION OVER A GLOBAL COMPUTER NETWORK, FOR LANGUAGE TRANSLATION, AND FOR VIEWING AND SHARING DIGITAL PHOTOS (U.S. CLS. 100 AND 101).

FIRST USE 12-7-2009; IN COMMERCE 12-7-2009.

4,016,471. SEARS BRANDS, LLC, HOFFMAN ESTATES, IL. SN 77-887,701. PUB. 11-2-2010, FILED 12-7-2009.

HEROES AT HOME

THE MARK CONSISTS OF STANDARD CHARACTERS WITHOUT CLAIM TO ANY PARTICULAR FONT, STYLE, SIZE, OR COLOR.

CLASS 36—INSURANCE AND FINANCIAL

FOR CHARITABLE FUNDRAISING SERVICES, NAMELY, COORDINATING THE PROCUREMENT OF MONETARY DONATIONS FROM THE GENERAL PUBLIC AND THE DISTRIBUTION OF RETAIL GIFT CARDS TO GROUPS OR INDIVIDUALS IN NEED (U.S. CLS. 100, 101 AND 102).

FIRST USE 4-0-2007; IN COMMERCE 4-0-2007.

CLASS 37—CONSTRUCTION AND REPAIR

FOR CHARITABLE SERVICES, NAMELY, REBUILDING, RENOVATING AND REPAIRING RESIDENTIAL HOUSING AND BUILDINGS FOR GROUPS AND INDIVIDUALS IN NEED (U.S. CLS. 100, 103 AND 106).

FIRST USE 4-0-2007; IN COMMERCE 4-0-2007.

CLASS 38—COMMUNICATION

FOR PROVIDING ONLINE FORUMS FOR TRANSMISSION OF MESSAGES AMONG COMPUTER USERS CONCERNING CHARITABLE SERVICES DIRECTED TO GROUPS AND INDIVIDUALS IN NEED AND OFFERING SUPPORT FOR SUCH GROUPS AND INDIVIDUALS (U.S. CLS. 100, 101 AND 104).

FIRST USE 4-0-2007; IN COMMERCE 4-0-2007.

4,016,473. LINDE AKTIENGESELLSCHAFT, AKA LINDE AG, 80331 MÜNCHEN/MUNICH, FED REP GERMANY. SN 77-887,796. PUB. 8-24-2010, FILED 12-7-2009.

LINSPRAY

THE MARK CONSISTS OF STANDARD CHARACTERS WITHOUT CLAIM TO ANY PARTICULAR FONT, STYLE, SIZE, OR COLOR.

CLASS 11—ENVIRONMENTAL CONTROL APPARATUS

FOR CARBON DIOXIDE COOLING SYSTEMS FOR USE IN SURFACE COATING AND THERMAL SPRAYING CONSISTING PRIMARILY OF A CARBON DIOXIDE HIGH PRESSURE TANK, WITHDRAWAL VALVES, SAFETY VALVES, A PRESSURE GAUGE, A HIGH PRESSURE HOSE AND SOLENOID VALVE WITH A FINE FILTER, AN EXPANSION NOZZLE, NOZZLE HOLDERS AND AN ELECTRONIC CONTROL PANEL (U.S. CLS. 13, 21, 23, 31 AND 34).

FIRST USE 4-0-1992; IN COMMERCE 2-0-2008.

CLASS 42—SCIENTIFIC AND COMPUTER SERVICES

FOR DESIGN AND DEVELOPMENT FOR OTHERS OF SYSTEMS FOR USE IN SURFACE COATING AND THERMAL SPRAYING; CUSTOM DESIGN OF SYSTEMS FOR USE IN SURFACE COATING AND THERMAL SPRAYING; TECHNICAL RESEARCH IN THE FIELD OF SURFACE COATING AND THERMAL SPRAYING; TECHNOLOGY CONSULTATION IN THE FIELD OF SURFACE COATING AND THERMAL SPRAYING; DESIGN AND TESTING FOR NEW PRODUCT DEVELOPMENT (U.S. CLS. 100 AND 101).

FIRST USE 4-0-2005; IN COMMERCE 1-0-2008.

4,016,475. SILEX MICROSYSTEMS AB, JÄRFÄLLA, SWEDEN. SN 77-888,697. PUB. 10-19-2010, FILED 12-8-2009.

SIL-CAP

THE MARK CONSISTS OF STANDARD CHARACTERS WITHOUT CLAIM TO ANY PARTICULAR FONT, STYLE, SIZE, OR COLOR.

PRIORITY CLAIMED UNDER SEC. 44(D) ON ERP N CMNTY TM OFC APPLICATION NO. 008724577, FILED 12-1-2009, REG. NO. 8724577, DATED 6-15-2010, EXPIRES 12-1-2019.

CLASS 40—MATERIAL TREATMENT

FOR MANUFACTURING AND CONTRACT MANUFACTURING, OF PRODUCTS FOR USE IN INDUSTRIAL APPLICATIONS IN THE NATURE OF MICRO ELECTRO-MECHANICAL OR MEMS DEVICES, SYSTEMS AND COMPONENTS, AND OTHER DEVICES, SYSTEMS AND COMPONENTS HAVING MICRO-SCALE OR MESO-SCALE FEATURES, COMPRISED OF MECHANICAL, ELECTRICAL, OPTICAL, FLUIDIC ELEMENTS, OR ANY COMBINATION THEREOF TO ORDER AND/OR SPECIFICATION OF OTHERS; PROTOTYPE FABRICATION OF NEW PRODUCTS FOR OTHERS (U.S. CLS. 100, 103 AND 106).

FIRST USE 1-0-2010; IN COMMERCE 1-0-2010.

CLASS 42—SCIENTIFIC AND COMPUTER SERVICES

FOR PRODUCT DEVELOPMENT AND DESIGN CONSULTING SERVICES AS WELL AS COMPUTER HARDWARE AND SOFTWARE CONSULTING SERVICES ALL IN THE FIELD OF INDUSTRIAL APPLICATIONS IN THE NATURE OF MICRO ELECTRO-MECHANICAL OR MEMS DEVICES, SYSTEMS AND COMPONENTS, AND OTHER DEVICES, SYSTEMS AND COMPONENTS HAVING MICRO-SCALE OR MESO-SCALE FEATURES, COMPRISED OF MECHANICAL, ELECTRICAL, OPTICAL, FLUIDIC ELEMENTS, OR ANY COMBINATION THEREOF (U.S. CLS. 100 AND 101).

FIRST USE 1-0-2010; IN COMMERCE 1-0-2010.

4,016,476. BEACON WELLNESS ADVISORS LLC, WATCHUNG, NJ. SN 77-888,930. PUB. 11-23-2010, FILED 12-8-2009.

BEACON WELLNESS ADVISORS

THE MARK CONSISTS OF STANDARD CHARACTERS WITHOUT CLAIM TO ANY PARTICULAR FONT, STYLE, SIZE, OR COLOR.

NO CLAIM IS MADE TO THE EXCLUSIVE RIGHT TO USE "WELLNESS ADVISORS", APART FROM THE MARK AS SHOWN.

CLASS 41—EDUCATION AND ENTERTAINMENT

FOR PROVIDING COACHING IN THE FIELD OF HEALTH, WELLNESS, NUTRITION, DIET, EXERCISE AND STRESS MANAGEMENT; CONDUCTING CORPORATE EDUCATIONAL PROGRAMS IN THE FIELD OF HEALTH, WELLNESS, NUTRITION, DIET, EXERCISE AND STRESS MANAGEMENT (U.S. CLS. 100, 101 AND 107).

FIRST USE 11-15-2009; IN COMMERCE 11-15-2009.

CLASS 44—MEDICAL, BEAUTY AND AGRICULTURAL SERVICES

FOR HEALTH CONSULTING SERVICES, NAMELY, PROVIDING COUNSELING SERVICES REGARDING HEALTH, WELLNESS, NUTRITION, DIET, EXERCISE AND STRESS MANAGEMENT; THE AFOREMENTIONED SERVICES PROVIDED THROUGH SPEAKING ENGAGEMENTS AND CORPORATE PROGRAMS (U.S. CLS. 100 AND 101).

FIRST USE 11-15-2009; IN COMMERCE 11-15-2009.

4,016,490. SIFTEO, INC., SAN FRANCISCO, CA. SN 77-892,823. PUB. 5-4-2010, FILED 12-14-2009.

SIFTEO

THE MARK CONSISTS OF STANDARD CHARACTERS WITHOUT CLAIM TO ANY PARTICULAR FONT, STYLE, SIZE, OR COLOR.

CLASS 9—ELECTRICAL AND SCIENTIFIC APPARATUS

FOR MULTIPLE SMALL BATTERY POWERED COMPUTERS WHICH CAN ACT IN CONCERT TO FORM A SINGLE INTERFACE WHICH RESPONDS TO THE USER'S PHYSICAL MANIPULATION OF ONE OR MORE UNITS, WITH EACH UNIT FEATURING ONE OR MORE OF MOTION SENSING, ATTITUDE SENSING, NEIGHBOR DETECTION, GRAPHICAL DISPLAY AND WIRELESS COMMUNICATION; SOFTWARE FOR CONTROL AND UTILIZATION OF SUCH UNITS (U.S. CLS. 21, 23, 26, 36 AND 38).

FIRST USE 5-1-2011; IN COMMERCE 5-1-2011.

CLASS 28—TOYS AND SPORTING GOODS

FOR APPARATUS FOR ELECTRONIC GAMES, OTHER THAN THOSE ADAPTED FOR USE WITH AN EXTERNAL DISPLAY SCREEN OR MONITOR, COMPRISED OF MULTIPLE SMALL BATTERY POWERED COMPUTERS CONFIGURED FOR ELECTRONIC GAMES WHICH CAN ACT IN CONCERT TO FORM A SINGLE INTERFACE WHICH RESPONDS TO THE USER'S PHYSICAL MANIPULATION OF ONE OR MORE UNITS, WITH EACH UNIT FEATURING ONE OR MORE OF MOTION SENSING, ATTITUDE SENSING, NEIGHBOR DETECTION, GRAPHICAL DISPLAY AND WIRELESS COMMUNICATION (U.S. CLS. 22, 23, 38 AND 50).

FIRST USE 5-1-2011; IN COMMERCE 5-1-2011.

4,016,493. PIKE NURSERIES ACQUISITION, LLC, DULUTH, GA. SN 77-893,460. PUB. 11-9-2010, FILED 12-15-2009.

PIKE NURSERIES

THE MARK CONSISTS OF STANDARD CHARACTERS WITHOUT CLAIM TO ANY PARTICULAR FONT, STYLE, SIZE, OR COLOR.

OWNER OF U.S. REG. NOS. 1,639,317 AND 1,827,852.

NO CLAIM IS MADE TO THE EXCLUSIVE RIGHT TO USE "NURSERIES", APART FROM THE MARK AS SHOWN.

SEC. 2(F).

CLASS 25—CLOTHING

FOR APPAREL, NAMELY, SHIRTS (U.S. CLS. 22 AND 39).

FIRST USE 3-4-2008; IN COMMERCE 3-4-2008.

CLASS 35—ADVERTISING AND BUSINESS

FOR RETAIL STORE SERVICES IN THE FIELD OF GARDENING, LAWN CARE, HORTICULTURE, LANDSCAPING, LAWN CARE PRODUCTS, GARDENING PRODUCTS AND PLANTS; RETAIL STORE SERVICES FEATURING SEEDS, FLOWERS, PLANTS, BUSHES, TREES, PINESTRAW, FERTILIZERS, DIRT, SOIL, HORTICULTURAL, LAWN CARE AND GARDENING PRODUCTS; RETAIL LAWN, GARDEN AND NURSERY STORES (U.S. CLS. 100, 101 AND 102).

FIRST USE 3-4-2008; IN COMMERCE 3-4-2008.

CLASS 44—MEDICAL, BEAUTY AND AGRICULTURAL SERVICES

FOR LANDSCAPE DESIGN, LANDSCAPE GARDENING, LANDSCAPE GARDENING DESIGN FOR OTHERS, LANDSCAPE SERVICES, GARDENING SERVICES, LAWN CARE SERVICES, PLANT NURSERIES AND PROVIDING A WEBSITE FEATURING INFORMATION IN THE FIELDS OF GARDENING, LANDSCAPING, LAWN CARE AND HORTICULTURE (U.S. CLS. 100 AND 101).

FIRST USE 3-4-2008; IN COMMERCE 3-4-2008.

CLASS 25—CLOTHING

FOR APPAREL, NAMELY, SHIRTS (U.S. CLS. 22 AND 39).

FIRST USE 3-4-2008; IN COMMERCE 3-4-2008.

CLASS 35—ADVERTISING AND BUSINESS

FOR RETAIL STORE SERVICES IN THE FIELD OF GARDENING, LAWN CARE, HORTICULTURE, LANDSCAPING, LAWN CARE PRODUCTS, GARDENING PRODUCTS AND PLANTS; RETAIL STORE SERVICES FEATURING SEEDS, FLOWERS, PLANTS, BUSHES, TREES, PINESTRAW, FERTILIZERS, DIRT, SOIL, HORTICULTURAL, LAWN CARE AND GARDENING PRODUCTS; RETAIL LAWN, GARDEN AND NURSERY STORES (U.S. CLS. 100, 101 AND 102).

FIRST USE 3-4-2008; IN COMMERCE 3-4-2008.

CLASS 44—MEDICAL, BEAUTY AND AGRICULTURAL SERVICES

FOR PLANT NURSERIES (U.S. CLS. 100 AND 101).

FIRST USE 3-4-2008; IN COMMERCE 3-4-2008.

4,016,494. PIKE NURSERIES ACQUISITION, LLC, DULUTH, GA. SN 77-893,462. PUB. 11-9-2010, FILED 12-15-2009.

PLAY IN THE DIRT

THE MARK CONSISTS OF STANDARD CHARACTERS WITHOUT CLAIM TO ANY PARTICULAR FONT, STYLE, SIZE, OR COLOR.

OWNER OF U.S. REG. NO. 2,005,587.

CLASS 35—ADVERTISING AND BUSINESS

FOR RETAIL STORE SERVICES IN THE FIELD OF GARDENING, LAWN CARE, HORTICULTURE, LANDSCAPING, LAWN CARE PRODUCTS, GARDENING PRODUCTS AND PLANTS; RETAIL STORE SERVICES FEATURING SEEDS, FLOWERS, PLANTS, BUSHES, TREES, PINESTRAW, FERTILIZERS, DIRT, SOIL, HORTICULTURAL, LAWN CARE AND GARDENING PRODUCTS; RETAIL LAWN, GARDEN AND NURSERY STORES (U.S. CLS. 100, 101 AND 102).

FIRST USE 3-4-2008; IN COMMERCE 3-4-2008.

CLASS 44—MEDICAL, BEAUTY AND AGRICULTURAL SERVICES

FOR LANDSCAPE DESIGN, LANDSCAPE GARDENING, LANDSCAPE GARDENING DESIGN FOR OTHERS, LANDSCAPE SERVICES, GARDENING SERVICES, LAWN CARE SERVICES, PLANT NURSERIES (U.S. CLS. 100 AND 101).

FIRST USE 3-4-2008; IN COMMERCE 3-4-2008.

4,016,495. PIKE NURSERIES ACQUISITION, LLC, DULUTH, GA. SN 77-893,485. PUB. 11-9-2010, FILED 12-15-2009.

I LOVE TO PLAY IN THE DIRT!

THE MARK CONSISTS OF STANDARD CHARACTERS WITHOUT CLAIM TO ANY PARTICULAR FONT, STYLE, SIZE, OR COLOR.

OWNER OF U.S. REG. NO. 2,005,587.

4,016,496. PIKE NURSERIES ACQUISITION, LLC, DULUTH, GA. SN 77-893,501. PUB. 11-9-2010, FILED 12-15-2009.

COME PLAY IN THE DIRT

THE MARK CONSISTS OF STANDARD CHARACTERS WITHOUT CLAIM TO ANY PARTICULAR FONT, STYLE, SIZE, OR COLOR.

OWNER OF U.S. REG. NO. 2,005,587.

CLASS 35—ADVERTISING AND BUSINESS

FOR RETAIL STORE SERVICES IN THE FIELD OF GARDENING, LAWN CARE, HORTICULTURE, LANDSCAPING, LAWN CARE PRODUCTS, GARDENING PRODUCTS AND PLANTS; RETAIL STORE SERVICES FEATURING SEEDS, FLOWERS, PLANTS, BUSHES, TREES, PINESTRAW, FERTILIZERS, DIRT, SOIL, HORTICULTURAL, LAWN CARE AND GARDENING PRODUCTS; RETAIL LAWN, GARDEN AND NURSERY STORES (U.S. CLS. 100, 101 AND 102).

FIRST USE 3-4-2008; IN COMMERCE 3-4-2008.

CLASS 44—MEDICAL, BEAUTY AND AGRICULTURAL SERVICES

FOR PLANT NURSERIES, PROVIDING A WEBSITE FEATURING INFORMATION IN THE FIELDS OF GARDENING, LANDSCAPING, LAWN CARE AND HORTICULTURE (U.S. CLS. 100 AND 101).

FIRST USE 3-4-2008; IN COMMERCE 3-4-2008.

4,016,497. VHA INC., IRVING, TX. SN 77-894,377. PUB. 11-2-2010, FILED 12-16-2009.

RESULTS ARE JUST THE BEGINNING

THE MARK CONSISTS OF STANDARD CHARACTERS WITHOUT CLAIM TO ANY PARTICULAR FONT, STYLE, SIZE, OR COLOR.

CLASS 35—ADVERTISING AND BUSINESS

FOR GROUP PURCHASING SERVICES RENDERED TO HOSPITALS, NAMELY, PROCURING OF CONTRACTS FOR THE PURCHASE AND SALE OF GOODS; CONSULTING IN THE FIELDS OF CLINICAL IMPROVEMENT AND OPERATIONAL IMPROVEMENT SERVICES RENDERED TO HOSPITALS AND HEALTH CLINICS, NAMELY, ASSISTANCE IN MANAGEMENT OF HOSPITAL BUSINESS ACTIVITIES TO IMPROVE CLINICAL AND OPERATIONAL PERFORMANCE; BUSINESS ANALYSIS SERVICES IN THE NATURE OF QUALITY AND PROFITABILITY ENHANCEMENT FOR HEALTH SERVICE PROVIDERS, HOSPITALS AND CLINICS; BUSINESS CONSULTING AND INFORMATION SERVICES IN THE FIELD OF PURCHASING OF SUPPLIES, SUPPLY CHAIN MANAGEMENT AND ACCOUNTING RELATED THERETO ALL BEING RENDERED TO HOSPITALS AND HEALTH CARE PROVIDERS (U.S. CLS. 100, 101 AND 102).

FIRST USE 4-30-2009; IN COMMERCE 4-30-2009.

CLASS 44—MEDICAL, BEAUTY AND AGRICULTURAL SERVICES

FOR PROVIDING INFORMATION IN THE FIELD OF HEALTH CARE (U.S. CLS. 100 AND 101).

FIRST USE 4-30-2009; IN COMMERCE 4-30-2009.

4,016,499. LAHA LIMITED, LONDON, UNITED KINGDOM. SN 77-894,603. PUB. 5-11-2010, FILED 12-16-2009.

LAHA

THE MARK CONSISTS OF STANDARD CHARACTERS WITHOUT CLAIM TO ANY PARTICULAR FONT, STYLE, SIZE, OR COLOR.

OWNER OF U.S. REG. NO. 2,785,314.

THE ENGLISH TRANSLATION OF "LAHA" IN THE MARK IS "FOR HER".

CLASS 9—ELECTRICAL AND SCIENTIFIC APPARATUS

FOR DOWNLOADABLE ELECTRONIC PUBLICATIONS IN THE NATURE OF MAGAZINES IN THE FIELD OF BUSINESS, ECONOMICS, FINANCE, POLITICS, EDUCATION, FASHION, DESIGN, ENTERTAINMENT, ARTS, MUSIC AND POPULAR CULTURE (U.S. CLS. 21, 23, 26, 36 AND 38).

FIRST USE 11-30-2010; IN COMMERCE 11-30-2010.

CLASS 41—EDUCATION AND ENTERTAINMENT

FOR PROVIDING ON-LINE MAGAZINES IN THE FIELD OF BUSINESS, ECONOMICS, FINANCE, POLITICS, EDUCATION, FASHION, DESIGN, ENTERTAINMENT, ARTS, MUSIC AND POPULAR CULTURE (U.S. CLS. 100, 101 AND 107).

FIRST USE 11-30-2010; IN COMMERCE 11-30-2010.

4,016,500. THE PET SAVERS FOUNDATION, INC., PORT WASHINGTON, NY. SN 77-894,913. PUB. 10-19-2010, FILED 12-16-2009.

RACE TO SAVE ANIMALS

THE MARK CONSISTS OF STANDARD CHARACTERS WITHOUT CLAIM TO ANY PARTICULAR FONT, STYLE, SIZE, OR COLOR.

CLASS 25—CLOTHING

FOR T-SHIRTS, CAPS, HATS, SWEATSHIRTS AND BANDANAS (U.S. CLS. 22 AND 39).

FIRST USE 6-14-2011; IN COMMERCE 6-14-2011.

CLASS 28—TOYS AND SPORTING GOODS

FOR PLUSH TOYS IN THE NATURE OF PLUSH CATS AND DOGS (U.S. CLS. 22, 23, 38 AND 50).

FIRST USE 6-14-2011; IN COMMERCE 6-14-2011.

CLASS 35—ADVERTISING AND BUSINESS

FOR PROMOTING PUBLIC AWARENESS FOR THE NEED OF ADOPTING ANIMALS, ANIMAL ADOPTION PLACEMENT, ANIMAL ADOPTION AGENCIES, SPAYING, NEUTERING AND OTHER VETERINARY SERVICES RELATED TO ANIMAL ADOPTION; PROMOTING THE SERVICES OF ANIMAL SHELTERS THROUGH DISTRIBUTION OF PRINTED MATERIAL AND INFORMATION ON THE INTERNET (U.S. CLS. 100, 101 AND 102).

FIRST USE 6-14-2011; IN COMMERCE 6-14-2011.

CLASS 36—INSURANCE AND FINANCIAL

FOR CHARITABLE FUNDRAISING SERVICES (U.S. CLS. 100, 101 AND 102).

FIRST USE 11-0-2010; IN COMMERCE 11-0-2010.

CLASS 41—EDUCATION AND ENTERTAINMENT

FOR EDUCATIONAL SERVICES, NAMELY, PROVIDING CLASSES AND SEMINARS IN THE FIELD OF HUMANE TREATMENT OF ANIMALS, AND DEVELOPING CURRICULUM FOR EDUCATORS (U.S. CLS. 100, 101 AND 107).

FIRST USE 6-14-2011; IN COMMERCE 6-14-2011.

CLASS 45—PERSONAL AND LEGAL SERVICES

FOR ANIMAL ADOPTION SERVICES FOR DOMESTIC ANIMALS (U.S. CLS. 100 AND 101).

FIRST USE 6-14-2011; IN COMMERCE 6-14-2011.

4,016,511. CHANDLER CHICCO COMPANIES LLC, NEW YORK, NY. SN 77-896,887. PUB. 11-23-2010, FILED 12-18-2009.

VERSTONE DIGITAL

THE MARK CONSISTS OF STANDARD CHARACTERS WITHOUT CLAIM TO ANY PARTICULAR FONT, STYLE, SIZE, OR COLOR.

NO CLAIM IS MADE TO THE EXCLUSIVE RIGHT TO USE "DIGITAL", APART FROM THE MARK AS SHOWN.

CLASS 35—ADVERTISING AND BUSINESS

FOR ADVERTISING AND MARKETING SERVICES; PUBLIC RELATIONS AND PUBLICITY SERVICES; PROMOTION AND MARKETING SERVICES AND RELATED CONSULTING; BUSINESS CONSULTATION; CORPORATE AND BRAND IDENTITY DEVELOPMENT CONSULTATION; CREATING CORPORATE AND BRAND IDENTITIES FOR OTHERS (U.S. CLS. 100, 101 AND 102). FIRST USE 2-11-2010; IN COMMERCE 2-11-2010.

CLASS 44—MEDICAL, BEAUTY AND AGRICULTURAL SERVICES

FOR PROVIDING INFORMATION IN THE FIELD OF HEALTH CARE (U.S. CLS. 100 AND 101). FIRST USE 2-11-2010; IN COMMERCE 2-11-2010.

4,016,514. THE KEY TV CORP., NEW YORK, NY. SN 77-897,917. PUB. 5-25-2010, FILED 12-21-2009.

THE KEY

THE MARK CONSISTS OF STANDARD CHARACTERS WITHOUT CLAIM TO ANY PARTICULAR FONT, STYLE, SIZE, OR COLOR.

CLASS 35—ADVERTISING AND BUSINESS

FOR PROMOTING THE GOODS AND SERVICES OF OTHERS IN THE RESTAURANT AND ENTERTAINMENT INDUSTRIES, NAMELY, PROVIDING VIDEO AND AUDIO CONTENT FEATURING THE GOODS AND SERVICES OF OTHERS IN THE NATURE OF ADVERTISING AND ADVERTISEMENTS VIA INTERNET AND MOBILE AND WIRELESS COMMUNICATION NETWORKS; PROMOTING THE GOODS AND SERVICES OF OTHERS BY PROVIDING CONSUMER INFORMATION IN THE FIELDS OF RESTAURANTS VIA INTERNET AND MOBILE AND WIRELESS COMMUNICATION NETWORKS; PROMOTING THE GOODS AND SERVICES OF OTHERS BY PROVIDING CONSUMER INFORMATION REGARDING MERCHANTS IN THE FIELDS OF RESTAURANTS AND ENTERTAINMENT VIA INTERNET AND MOBILE AND WIRELESS COMMUNICATION NETWORKS; PROVIDING PROMOTIONAL INFORMATION IN THE NATURE OF ADVERTISING AND ADVERTISEMENTS TO CONSUMERS VIA INTERNET AND MOBILE AND WIRELESS COMMUNICATION NETWORKS (U.S. CLS. 100, 101 AND 102).

FIRST USE 3-8-2010; IN COMMERCE 3-8-2010.

CLASS 41—EDUCATION AND ENTERTAINMENT

FOR MULTIMEDIA ENTERTAINMENT SERVICES IN THE NATURE OF CONTENT PREPARATION, RECORDING, PRODUCTION AND POST-PRODUCTION SERVICES IN THE FIELDS OF VIDEOS AND FILMS (U.S. CLS. 100, 101 AND 107).

FIRST USE 3-0-2010; IN COMMERCE 3-0-2010.

4,016,515. THE KEY TV CORP., NEW YORK, NY. SN 77-897,931. PUB. 5-25-2010, FILED 12-21-2009.



THE MARK CONSISTS OF A HORIZONTAL IMAGE OF A KEY ABOVE THE WORDING "THE KEY", ALL ON A RECTANGULAR SOLID BACKGROUND.

CLASS 35—ADVERTISING AND BUSINESS

FOR PROMOTING THE GOODS AND SERVICES OF OTHERS IN THE RESTAURANT AND ENTERTAINMENT INDUSTRIES, NAMELY, PROVIDING VIDEO AND AUDIO CONTENT FEATURING THE GOODS AND SERVICES OF OTHERS IN THE NATURE OF ADVERTISING AND ADVERTISEMENTS VIA INTERNET AND MOBILE AND WIRELESS COMMUNICATION NETWORKS; PROMOTING THE GOODS AND SERVICES OF OTHERS BY PROVIDING CONSUMER INFORMATION IN THE FIELDS OF RESTAURANTS VIA INTERNET AND MOBILE AND WIRELESS COMMUNICATION NETWORKS; PROMOTING THE GOODS AND SERVICES OF OTHERS BY PROVIDING CONSUMER INFORMATION REGARDING MERCHANTS IN THE FIELDS OF RESTAURANTS AND ENTERTAINMENT VIA INTERNET AND MOBILE AND WIRELESS COMMUNICATION NETWORKS; PROVIDING PROMOTIONAL INFORMATION IN THE NATURE OF ADVERTISING AND ADVERTISEMENTS TO CONSUMERS VIA INTERNET AND MOBILE AND WIRELESS COMMUNICATION NETWORKS (U.S. CLS. 100, 101 AND 102).

FIRST USE 3-8-2010; IN COMMERCE 3-8-2010.

CLASS 41—EDUCATION AND ENTERTAINMENT

FOR MULTIMEDIA ENTERTAINMENT SERVICES IN THE NATURE OF CONTENT PREPARATION, RECORDING, PRODUCTION AND POST-PRODUCTION SERVICES IN THE FIELDS OF VIDEOS AND FILMS (U.S. CLS. 100, 101 AND 107).

FIRST USE 3-0-2010; IN COMMERCE 3-0-2010.

4,016,516. THE LACLEDE GROUP, INC., ST. LOUIS, MO. SN 77-900,347. PUB. 11-23-2010, FILED 12-23-2009.



OWNER OF U.S. REG. NO. 3,104,574.
NO CLAIM IS MADE TO THE EXCLUSIVE RIGHT TO USE "GAS", APART FROM THE MARK AS SHOWN.
THE COLOR(S) GREEN, BLUE AND BLACK IS/ARE CLAIMED AS A FEATURE OF THE MARK.
THE MARK CONSISTS OF THE WORDS "LACLEDE GAS" IN BOLD BLACK LETTERS, TO THE LEFT OF THE WORD ELEMENTS APPEARS A BLACK RECTANGLE WITH A GREEN LEAF WITH RIBBING INSIDE, A BLUE FLAME ELEMENT APPEARS TO THE RIGHT OF THE RECTANGLE WITH A THIN BLACK ARROW INTERSECTING THE LOWER PART OF THE RECTANGLE AND FLAME WITH THE POINT FACING TO THE RIGHT AND ENDING UNDERNEATH THE LETTER "L".

CLASS 36—INSURANCE AND FINANCIAL

FOR FINANCING OF ENERGY-RELATED PRODUCTS, NAMELY, FURNACES, GAS FIREPLACES, LOGS, CARBON MONOXIDE DETECTORS, THERMOSTATS, GRILLS, RANGES AND CLOTHES DRYERS; ENERGY BROKERAGE SERVICES, NAMELY, NATURAL GAS (U.S. CLS. 100, 101 AND 102).
FIRST USE 4-1-2010; IN COMMERCE 4-1-2010.

CLASS 39—TRANSPORTATION AND STORAGE

FOR PUBLIC UTILITY SERVICES IN THE NATURE OF NATURAL GAS DISTRIBUTION; TRANSMISSION OF UTILITY GAS THROUGH PIPELINES; STORAGE OF PROPANE; DELIVERY AND TRANSPORTATION OF PROPANE BY PIPELINE (U.S. CLS. 100 AND 105).
FIRST USE 4-1-2010; IN COMMERCE 4-1-2010.

4,016,517. THE LACLEDE GROUP, INC., ST. LOUIS, MO. SN 77-900,354. PUB. 11-23-2010, FILED 12-23-2009.



THE COLOR(S) GREEN, BLUE AND BLACK IS/ARE CLAIMED AS A FEATURE OF THE MARK.
THE MARK CONSISTS OF A BLACK RECTANGULAR ELEMENT WITH A GREEN LEAF WITH RIBBING INSIDE, A BLUE FLAME ELEMENT APPEARS TO THE RIGHT OF THE RECTANGLE WITH A THIN BLACK ARROW INTERSECTING THE LOWER PART OF THE RECTANGLE AND FLAME WITH THE POINT FACING TO THE RIGHT.

CLASS 36—INSURANCE AND FINANCIAL

FOR FINANCING OF ENERGY-RELATED PRODUCTS, NAMELY, FURNACES, GAS FIREPLACES, LOGS, CARBON MONOXIDE DETECTORS, THERMOSTATS, GRILLS, RANGES AND CLOTHES DRYERS; ENERGY BROKERAGE SERVICES, NAMELY, NATURAL GAS (U.S. CLS. 100, 101 AND 102).
FIRST USE 4-1-2010; IN COMMERCE 4-1-2010.

CLASS 39—TRANSPORTATION AND STORAGE

FOR PUBLIC UTILITY SERVICES IN THE NATURE OF NATURAL GAS DISTRIBUTION; TRANSMISSION OF UTILITY GAS THROUGH PIPELINES; STORAGE OF PROPANE; DELIVERY AND TRANSPORTATION OF PROPANE BY PIPELINE (U.S. CLS. 100 AND 105).
FIRST USE 4-1-2010; IN COMMERCE 4-1-2010.

4,016,521. HEP TECH CO., LTD., TAICHUNG CITY, TAIWAN. SN 77-901,694. PUB. 11-16-2010, FILED 12-28-2009.



OWNER OF U.S. REG. NO. 3,291,552.
NO CLAIM IS MADE TO THE EXCLUSIVE RIGHT TO USE "LIGHT", APART FROM THE MARK AS SHOWN.
THE COLOR(S) RED AND GREEN IS/ARE CLAIMED AS A FEATURE OF THE MARK.
THE MARK CONSISTS OF PARTIALLY SHADED GREEN SQUARE, WITHIN WHICH THE WORDING "HEP" IS IN COLOR RED; AND THE ITALICIZED WORD "OWER FOR LIGHT" IS IN COLOR RED.

CLASS 9—ELECTRICAL AND SCIENTIFIC APPARATUS

FOR ELECTRICAL SWITCHES, POWER SWITCHES; ELECTRICAL TRANSFORMERS; URGENT POWER SUPPLY, NAMELY, ELECTRONIC EMERGENCY WARNING LIGHTS USED ON ELECTRONIC OR ELECTROMAGNETIC BALLAST WITH BATTERIES; ELECTRIC LIGHT DIMMERS; ELECTRONIC LIGHTING BALLASTS; FLUORESCENT LAMP BALLAST FOR ELECTRIC LIGHTS; ELECTRIC PLUGS; ELECTRIC SWITCHES, ELECTRIC LIGHT SWITCHES, CAPACITORS; COMMUTATORS; VOLTAGE SURGE PROTECTORS; LED AND HID LIGHT CONTROLS; ELECTRONIC REGULATING AND CONTROL DEVICES FOR THE OPERATION OF LIGHT EMITTING DIODES (U.S. CLS. 21, 23, 26, 36 AND 38).
FIRST USE 10-27-2007; IN COMMERCE 5-17-2011.

CLASS 11—ENVIRONMENTAL CONTROL APPARATUS

FOR ELECTRIC LIGHTING FIXTURES, LED LIGHTING FIXTURES; LED AND HID LIGHT FIXTURES; LED LIGHT ASSEMBLIES FOR STREET LIGHTS, SIGNS, COMMERCIAL LIGHTING, AUTOMOBILES, BUILDINGS, AND OTHER ARCHITECTURAL USES; LED LIGHTING FIXTURES FOR USE IN DISPLAY, COMMERCIAL, INDUSTRIAL, RESIDENTIAL, AND ARCHITECTURAL ACCENT LIGHTING APPLICATIONS; FLASHLIGHTS, LED LIGHT ASSEMBLIES FOR STREET LIGHTS; SOLAR LIGHT FIXTURES, NAMELY, INDOOR AND OUTDOOR SOLAR POWERED LIGHTING UNITS AND FIXTURES; ELECTRIC LIGHT BULBS, LED LIGHT BULBS, LAMP BULBS; SEARCHLIGHTS; SAFETY LIGHTS, NAMELY, ELECTRIC LIGHTING FIXTURE USED IN POWER FAILURE BACKUP SAFETY LIGHTING, EMERGENCY LIGHT BULBS FOR EMERGENCY SAFETY LIGHTING; LIGHTING APPARATUS FOR VEHICLES, LIGHTS FOR VEHICLES, BICYCLE LIGHTS, VEHICLE TURN-SIGNAL LIGHT BULBS; ELECTRIC LUMINAIRES; LUMINAIRES; LUMINARIES, USING LIGHT EMITTING DIODES AS A LIGHT SOURCE, FOR STREET OR ROADWAY LIGHTING; LAMPS, FLUORESCENT LAMPS, FLUORESCENT LAMP TUBES, LAMPS FOR OUTDOOR USE (U.S. CLS. 13, 21, 23, 31 AND 34).

FIRST USE 10-27-2007; IN COMMERCE 5-17-2011.

4,016,554. C AND A COURTENAY MINISTRIES, BROOKLYN, NY. SN 77-918,609. PUB. 12-21-2010, FILED 1-23-2010.



THE COLOR(S) GOLD, BLACK, BLUE AND SILVER IS/ARE CLAIMED AS A FEATURE OF THE MARK.

THE MARK CONSISTS OF A SCALE WITH BLACK AND GOLD, SILVER AND BLUE LEVER; GOLD BEAM HOLDING SILVER CHAINS THAT SUSPEND SILVER AND GOLD PLATES; SITTING ON THE PLATES ARE GOLD BARS ENGRAVED WITH THE WORDS "FAMILY", "RELATIONSHIP", "EDUCATION", "HEALTH", "FINANCE", "REST", "WORK", "SPIRITUALITY"; AT THE TOP OF THE HORIZONTAL BEAM THERE IS A BLACK ROUND TIP WITH GOLD AND BLUE; CROSS; THE WORDS "REACHING FOR THE BALANCING POINT" IN GOLD COLOR ABOVE THE SCALE.

4,016,522. REIDER, CRAIG A., WHEELING, IL. SN 77-902,703. PUB. 10-26-2010, FILED 12-30-2009.

AGINGUP

THE MARK CONSISTS OF STANDARD CHARACTERS WITHOUT CLAIM TO ANY PARTICULAR FONT, STYLE, SIZE, OR COLOR.

CLASS 35—ADVERTISING AND BUSINESS

FOR BUSINESS CONSULTATION AND MARKETING RESEARCH (U.S. CLS. 100, 101 AND 102).
FIRST USE 5-31-2011; IN COMMERCE 5-31-2011.

CLASS 41—EDUCATION AND ENTERTAINMENT

FOR EDUCATIONAL WORKSHOPS, SEMINARS, CLASSES AND CONFERENCES IN THE FIELDS OF BUSINESS, MARKETING AND MARKETING RESEARCH (U.S. CLS. 100, 101 AND 107).
FIRST USE 5-31-2011; IN COMMERCE 5-31-2011.

CLASS 16—PAPER GOODS AND PRINTED MATTER

FOR SCHOOL SUPPLY KITS CONTAINING VARIOUS COMBINATIONS OF SELECTED SCHOOL SUPPLIES, NAMELY, WRITING INSTRUMENTS, PENS, PENCILS, MECHANICAL PENCILS, ERASERS, MARKERS, CRAYONS, HIGHLIGHTER PENS, FOLDERS, NOTEBOOKS, PAPER, PROTRACTORS, PAPER CLIPS, PENCIL SHARPENERS, WRITING GRIPS, GLUE AND BOOK MARKS (U.S. CLS. 2, 5, 22, 23, 29, 37, 38 AND 50).
FIRST USE 9-1-2009; IN COMMERCE 3-1-2010.

CLASS 18—LEATHER GOODS

FOR BACKPACKS, BOOK BAGS, SPORTS BAGS, BUM BAGS, WALLETS AND HANDBAGS (U.S. CLS. 1, 2, 3, 22 AND 41).
FIRST USE 9-1-2009; IN COMMERCE 10-28-2009.

CLASS 24—FABRICS

FOR HAND TOWELS (U.S. CLS. 42 AND 50).
FIRST USE 9-1-2009; IN COMMERCE 3-1-2010.

CLASS 25—CLOTHING

FOR ATHLETIC APPAREL, NAMELY, SHIRTS, PANTS, JACKETS, FOOTWEAR, HATS AND CAPS, ATHLETIC UNIFORMS (U.S. CLS. 22 AND 39).
FIRST USE 9-1-2009; IN COMMERCE 10-2-2009.

CLASS 36—INSURANCE AND FINANCIAL

FOR CHARITABLE FUND RAISING BY MEANS OF CONDUCTING BOOK DRIVES WHEREIN THE BOOKS ARE LATER SOLD AND PROCEEDS DONATED TO CHARITY (U.S. CLS. 100, 101 AND 102).
FIRST USE 9-1-2009; IN COMMERCE 10-28-2009.

CLASS 41—EDUCATION AND ENTERTAINMENT

FOR BOOK PUBLISHING (U.S. CLS. 100, 101 AND 107).
FIRST USE 9-1-2009; IN COMMERCE 10-28-2009.

CLASS 45—PERSONAL AND LEGAL SERVICES

FOR PROVIDING A WEBSITE FEATURING INFORMATION ABOUT RELIGIOUS BELIEF SYSTEMS; PROVIDING A WEBSITE FEATURING INFORMATION FOR LOCAL CHURCH LEADERS IN THE FIELD OF CHRISTIAN GROWTH; PROVIDING A WEBSITE FEATURING INSPIRATIONAL AND MOTIVATIONAL NEWS STORIES ABOUT WOMEN (U.S. CLS. 100 AND 101).
FIRST USE 9-1-2009; IN COMMERCE 10-2-2009.

CLASS 41—EDUCATION AND ENTERTAINMENT

FOR PROVIDING ON-LINE COMPUTER DATABASES AND ONLINE SEARCHABLE DATABASES IN THE FIELD OF COLLEGIATE LIFE CONCERNING COLLEGE ATHLETICS, CONCERTS, ENTERTAINMENT EVENTS, ART, PERFORMING ARTS, MUSIC, DANCE AND ACADEMICS; PROVIDING ON-LINE COMPUTER DATABASES AND ON-LINE SEARCHABLE DATABASES FEATURING COLLEGIATE STUDENT GROUPS CONCERNING SUBJECTS IN THE FIELDS OF ACADEMICS AND ENTERTAINMENT, PROVIDING ON-LINE COMPUTER DATABASES AND ON-LINE SEARCHABLE DATABASES IN THE FIELD OF PHOTO SHARING AND VIDEO SHARING (U.S. CLS. 100, 101 AND 107).
FIRST USE 12-15-2010; IN COMMERCE 12-15-2010.

CLASS 42—SCIENTIFIC AND COMPUTER SERVICES

FOR COMPUTER SERVICES, NAMELY, HOSTING ONLINE WEB FACILITIES FOR OTHERS FOR ORGANIZING AND CONDUCTING ONLINE MEETINGS, GATHERINGS, AND INTERACTIVE DISCUSSIONS; AND COMPUTER SERVICES IN THE NATURE OF CUSTOMIZED WEB PAGES FEATURING USER-DEFINED INFORMATION, PERSONAL PROFILES AND INFORMATION; PROVIDING ON-LINE COMPUTER DATABASES AND ON-LINE SEARCHABLE DATABASES IN THE FIELD OF FORMING AND CONNECTING WITH A VIRTUAL COMMUNITY (U.S. CLS. 100 AND 101).
FIRST USE 12-15-2010; IN COMMERCE 12-15-2010.

4,016,556. JAMES A. PARKER, OAK PARK, IL. SN 77-919,780. PUB. 11-2-2010, FILED 1-25-2010.

PARAFINCH

THE MARK CONSISTS OF STANDARD CHARACTERS WITHOUT CLAIM TO ANY PARTICULAR FONT, STYLE, SIZE, OR COLOR.

CLASS 35—ADVERTISING AND BUSINESS

FOR PROVIDING AN ONLINE DIRECTORY INFORMATION SERVICE FEATURING INFORMATION REGARDING, AND IN THE NATURE OF, SOCIAL NETWORKING SITES; ADVERTISING AND INFORMATION DISTRIBUTION SERVICES, NAMELY, PROVIDING CLASSIFIED ADVERTISING SPACE VIA THE GLOBAL COMPUTER NETWORK; PROMOTING THE GOODS AND SERVICES OF OTHERS OVER THE INTERNET; AND PROVIDING ON-LINE COMPUTER DATABASES AND ON-LINE SEARCHABLE DATABASES IN THE FIELD OF CLASSIFIED ADVERTISEMENTS (U.S. CLS. 100, 101 AND 102).
FIRST USE 12-15-2010; IN COMMERCE 12-15-2010.

CLASS 38—COMMUNICATION

FOR PROVIDING ONLINE CHAT ROOMS AND ELECTRONIC BULLETIN BOARDS FOR REGISTERED USERS FOR TRANSMISSION OF MESSAGES CONCERNING COLLEGIATE LIFE, GENERAL INTEREST, CLASSIFIEDS, VIRTUAL COMMUNITY, SOCIAL NETWORKING, PHOTO SHARING, AND TRANSMISSION OF PHOTOGRAPHIC IMAGES; PROVIDING ON-LINE COMPUTER DATABASES AND ON-LINE SEARCHABLE DATABASES IN THE FIELD OF TRANSMISSION OF PHOTOGRAPHIC IMAGES; PROVISION OF ON-LINE FORUMS FOR COMMUNICATIONS ON TOPICS OF GENERAL INTEREST (U.S. CLS. 100, 101 AND 104).
FIRST USE 12-15-2010; IN COMMERCE 12-15-2010.

CLASS 45—PERSONAL AND LEGAL SERVICES

FOR INTERNET BASED INTRODUCTION AND SOCIAL NETWORKING SERVICES; PROVIDING ON-LINE COMPUTER DATABASES AND ON-LINE SEARCHABLE DATABASES IN THE FIELD OF SOCIAL NETWORKING (U.S. CLS. 100 AND 101).
FIRST USE 12-15-2010; IN COMMERCE 12-15-2010.

4,016,571. CITRUS SPORTS GROUP, LLC, WALTHAM, MA. SN 77-927,094. PUB. 1-11-2011, FILED 2-3-2010.



NO CLAIM IS MADE TO THE EXCLUSIVE RIGHT TO USE "FC" OR "TAMPA BAY", APART FROM THE MARK AS SHOWN.

THE MARK CONSISTS OF A SHIELD, HAVING THE LETTERS "FC" APPEARING ON A PORTION OF THE SHIELD, WHEREIN A SOCCER BALL IS DISPLACED INSIDE THE LETTER "C", FURTHER HAVING THE WORDS "TAMPA BAY" APPEARING ON AN ALTERNATE PORTION OF THE SHIELD, AND WHEREIN A STAR DESIGN IS DISPLACED ABOVE THE SHIELD.

CLASS 25—CLOTHING

FOR CLOTHING, NAMELY, T-SHIRTS, SWEAT-SHIRTS, JERSEYS, HATS, AND CAPS (U.S. CLS. 22 AND 39).

FIRST USE 3-0-2010; IN COMMERCE 3-0-2010.

CLASS 38—COMMUNICATION

FOR INTERNET, RADIO, AND TELEVISION BROADCASTING SERVICES IN THE FIELD OF SPORTS; PROVIDING AN ONLINE USER DISCUSSION FORUM FOR TRANSMISSION OF MESSAGES AMONG COMPUTER USERS CONCERNING SPORTS (U.S. CLS. 100, 101 AND 104).

FIRST USE 3-0-2010; IN COMMERCE 4-0-2010.

CLASS 41—EDUCATION AND ENTERTAINMENT

FOR SERVICES IN THE NATURE OF SPORTING EVENTS, NAMELY, GAMES, COMPETITIONS, AND TOURNAMENTS FEATURING THE SPORT OF SOCCER; ONLINE ENTERTAINMENT SERVICES, NAMELY, PROVISION OF A WEB SITE FEATURING INTERACTIVE QUIZZES IN THE FIELD OF SPORTS AND NON-DOWNLOADABLE SPORTS VIDEO CLIPS (U.S. CLS. 100, 101 AND 107).

FIRST USE 3-0-2010; IN COMMERCE 4-0-2010.

4,016,573. MOBI MUNCH, CARSON CITY, NV. SN 77-930,502. PUB. 11-2-2010, FILED 2-8-2010.

WE LOVE FOOD TRUCKS!

THE MARK CONSISTS OF STANDARD CHARACTERS WITHOUT CLAIM TO ANY PARTICULAR FONT, STYLE, SIZE, OR COLOR.

NO CLAIM IS MADE TO THE EXCLUSIVE RIGHT TO USE "FOOD TRUCKS", APART FROM THE MARK AS SHOWN.

CLASS 35—ADVERTISING AND BUSINESS

FOR ADVERTISING AND BUSINESS MANAGEMENT CONSULTANCY; ADVERTISING, MARKETING AND PROMOTION SERVICES; BUSINESS CONSULTING AND INFORMATION SERVICES; BUSINESS MANAGEMENT CONSULTING; MOBILE FOOD KIOSK SERVICES; MOBILE STREET VENDOR SERVICES FEATURING FOOD AND DRINK; ON-LINE ADVERTISING AND MARKETING SERVICES; ON-LINE BUSINESS DIRECTORIES FEATURING MOBILE FOOD STREET VENDORS; PROVIDING ON-LINE CONSUMER INFORMATION CONCERNING THE LOCATION OF MOBILE RESTAURANTS AND MOBILE FOOD STREET VENDORS; REFERRALS IN THE FIELD OF RESTAURANTS (U.S. CLS. 100, 101 AND 102).

FIRST USE 3-0-2011; IN COMMERCE 3-0-2011.

CLASS 38—COMMUNICATION

FOR PROVIDING ON-LINE ELECTRONIC BULLETIN BOARDS FOR TRANSMISSION OF MESSAGES AMONG COMPUTER USERS CONCERNING RESTAURANTS REVIEWS, RATINGS, REFERRALS AND RECOMMENDATIONS OF RESTAURANTS AND MOBILE FOOD STREET VENDORS (U.S. CLS. 100, 101 AND 104).

FIRST USE 3-0-2011; IN COMMERCE 3-0-2011.

CLASS 39—TRANSPORTATION AND STORAGE

FOR LEASING OF MOBILE FOOD KIOSK VEHICLE (U.S. CLS. 100 AND 105).

FIRST USE 3-0-2011; IN COMMERCE 3-0-2011.

CLASS 42—SCIENTIFIC AND COMPUTER SERVICES

FOR PROVIDING, NAMELY, HOSTING AN ONLINE COMMUNITY FOR USERS TO SHARE INFORMATION, PHOTOS, AUDIO AND VIDEO CONTENT ABOUT THEMSELVES, THEIR LIKES AND DISLIKES AND DAILY ACTIVITIES, TO GET FEEDBACK FROM THEIR PEERS, TO FORM VIRTUAL COMMUNITIES (U.S. CLS. 100 AND 101).

FIRST USE 3-0-2011; IN COMMERCE 3-0-2011.

CLASS 43—HOTEL AND RESTAURANT SERVICES

FOR PROVIDING REVIEWS OF RESTAURANTS; PROVIDING REVIEWS OF MOBILE FOOD STREET VENDORS; PROVIDING INFORMATION ABOUT RESTAURANT SERVICES, NAMELY, COMPILATIONS OF INFORMATION COLLECTED BY OTHERS, RANKINGS, REVIEWS AND RECOMMENDATIONS RELATING TO RESTAURANTS FOR FOOD AND BEVERAGE APPRECIATION PURPOSES USING THE GLOBAL COMPUTER NETWORK (U.S. CLS. 100 AND 101).

FIRST USE 3-0-2011; IN COMMERCE 3-0-2011.

4,016,602. DSM IP ASSETS B.V., HEERLEN, NETHERLANDS. SN 77-942,371. PUB. 11-30-2010, FILED 2-23-2010.

BERRY BEAUTIFUL

THE MARK CONSISTS OF STANDARD CHARACTERS WITHOUT CLAIM TO ANY PARTICULAR FONT, STYLE, SIZE, OR COLOR.

NO CLAIM IS MADE TO THE EXCLUSIVE RIGHT TO USE "BERRY", APART FROM THE MARK AS SHOWN.

CLASS 5—PHARMACEUTICALS

FOR NUTRITIONAL AND DIETARY FOOD SUPPLEMENTS (U.S. CLS. 6, 18, 44, 46, 51 AND 52).

FIRST USE 3-11-2010; IN COMMERCE 3-11-2010.

CLASS 30—STAPLE FOODS

FOR GRANOLA-BASED SNACK BARS; READY TO EAT, CEREAL DERIVED FOOD BARS (U.S. CL. 46).

FIRST USE 3-11-2010; IN COMMERCE 3-11-2010.

4,016,607. ROCKEFELLER & CO., INC., NEW YORK, NY. SN 77-945,098. PUB. 2-8-2011, FILED 2-25-2010.



NO CLAIM IS MADE TO THE EXCLUSIVE RIGHT TO USE "FINANCIAL", APART FROM THE MARK AS SHOWN.

THE MARK CONSISTS OF THE WORDS "ROCKEFELLER FINANCIAL" TOGETHER WITH A STYLIZED GLOBE DESIGN.

CLASS 35—ADVERTISING AND BUSINESS

FOR ACCOUNTING SERVICES; TAX AND TAXATION PLANNING, ADVICE, INFORMATION AND CONSULTANCY SERVICES; TAX PREPARATION AND FILING SERVICES; PERSONAL BUDGET PREPARATION; BUSINESS MANAGEMENT AND ADVICE; HUMAN RESOURCES CONSULTATION (U.S. CLS. 100, 101 AND 102).

FIRST USE 3-1-2010; IN COMMERCE 3-1-2010.

CLASS 36—INSURANCE AND FINANCIAL

FOR FINANCIAL SERVICES, NAMELY, FINANCIAL CONSULTATION, FINANCIAL PLANNING, FINANCIAL PORTFOLIO MANAGEMENT, INVESTMENT OF FUNDS FOR OTHERS, FINANCIAL AND INVESTMENT INFORMATION MANAGEMENT FOR OTHERS, AND MANAGEMENT OF CAPITAL INVESTMENT FUNDS, HEDGE FUNDS, PRIVATE EQUITY FUNDS AND OTHER COLLECTIVE INVESTMENT VEHICLES; INVESTMENT CONSULTATION; INVESTMENT MANAGEMENT AND ADVISORY SERVICES FOR DISCRETIONARY AND NON-DISCRETIONARY DOMESTIC AND FOREIGN ACCOUNTS FOR HIGH NET WORTH INDIVIDUALS, FAMILIES, CORPORATIONS, PARTNERSHIPS, LIMITED LIABILITY COMPANIES, CHARITABLE INSTITUTIONS, TRUSTS AND ESTATES; INVESTMENT SUPERVISORY SERVICES IN CONNECTION WITH OPEN ARCHITECTURE PROGRAMS, NAMELY, FINANCIAL PLANNING, CONDUCTING FINANCIAL REVIEWS, INVESTMENT ADVICE, ASSET ALLOCATION, AND FINANCIAL ANALYSIS AND CONSULTATION; TRUST SERVICES, NAMELY, INVESTMENT AND TRUST COMPANY SERVICES; FIDUCIARY SERVICES, NAMELY, FIDUCIARY REPRESENTATIVE SERVICES; INVESTMENT ADVISORY SERVICES; INVESTMENT CONSULTATION; INVESTMENT MANAGEMENT; ESTATE PLANNING; BILL PAYMENT SERVICES; ADMINISTRATION OF EMPLOYEE BENEFIT PLANS (U.S. CLS. 100, 101 AND 102).

FIRST USE 3-1-2010; IN COMMERCE 3-1-2010.

4,016,609. BAKER STREET PUBLISHING, LLC, SAN FRANCISCO, CA. SN 77-945,587. PUB. 3-15-2011, FILED 2-26-2010.

BAKER STREET PUBLISHING

THE MARK CONSISTS OF STANDARD CHARACTERS WITHOUT CLAIM TO ANY PARTICULAR FONT, STYLE, SIZE, OR COLOR.

NO CLAIM IS MADE TO THE EXCLUSIVE RIGHT TO USE "PUBLISHING", APART FROM THE MARK AS SHOWN.

CLASS 9—ELECTRICAL AND SCIENTIFIC APPARATUS

FOR DOWNLOADABLE ELECTRONIC PUBLICATIONS IN THE NATURE OF CASE STUDY REPORTS, DIGITAL BOOKS AND COACHING GUIDES IN THE FIELDS OF ORGANIZATIONAL AND COLLABORATIVE DESIGN, DECISION MAKING AND LEARNING STRATEGIES; COMPUTER SOFTWARE FOR USE IN THE FIELDS OF ORGANIZATIONAL AND COLLABORATIVE DESIGN, DECISION MAKING AND LEARNING STRATEGIES (U.S. CLS. 21, 23, 26, 36 AND 38).

FIRST USE 2-0-2009; IN COMMERCE 2-0-2009.

CLASS 35—ADVERTISING AND BUSINESS

FOR PROVIDING ORGANIZATIONAL DEVELOPMENT CONSULTING SERVICES FOR BUSINESS, GOVERNMENT AND NOT-FOR-PROFIT ENTITIES FEATURING INFORMATION CONCERNING ORGANIZATIONAL AND COLLABORATIVE DESIGN, DECISION MAKING AND LEARNING STRATEGIES; PROVIDING INFORMATION IN THE FIELD OF ORGANIZATIONAL DEVELOPMENT VIA THE INTERNET AND OTHER ELECTRONIC COMMUNICATIONS NETWORKS, FEATURING INFORMATION CONCERNING ORGANIZATIONAL AND COLLABORATIVE DESIGN, DECISION MAKING AND LEARNING STRATEGIES, FOR BUSINESS, GOVERNMENT AND NOT-FOR-PROFIT ENTITIES (U.S. CLS. 100, 101 AND 102).

FIRST USE 12-0-2010; IN COMMERCE 12-0-2010.

CLASS 41—EDUCATION AND ENTERTAINMENT

FOR EDUCATIONAL SERVICES, NAMELY, PROVIDING SEMINARS, LECTURES, PRESENTATIONS, VIDEO TRAINING AND ONLINE TUTORIALS IN THE FIELDS OF ORGANIZATIONAL AND COLLABORATIVE DESIGN, DECISION MAKING AND LEARNING STRATEGIES (U.S. CLS. 100, 101 AND 107).

FIRST USE 9-0-2010; IN COMMERCE 9-0-2010.

4,016,610. CROSCILL HOME LLC, NEW YORK, NY. SN 77-945,710. PUB. 7-27-2010, FILED 2-26-2010.

CHAPEL HILL

THE MARK CONSISTS OF STANDARD CHARACTERS WITHOUT CLAIM TO ANY PARTICULAR FONT, STYLE, SIZE, OR COLOR.

CLASS 20—FURNITURE AND ARTICLES NOT OTHERWISE CLASSIFIED

FOR DECORATIVE PILLOWS, NON-METAL SHOWER CURTAIN HOOKS, AND METAL AND NON-METAL SHOWER CURTAIN RINGS; NON-METAL HARDWARE FOR DRAPERIES AND CURTAINS, NAMELY, RODS, POLES, TUBING AND TRACKS, AND FINIALS; BATHROOM ACCESSORIES MADE OF METAL, NAMELY, SHOWER CURTAIN HOOKS; METAL HARDWARE FOR USE WITH DRAPERIES AND CURTAINS, NAMELY, RODS, POLES, TUBING AND TRACKS, AND FINIALS (U.S. CLS. 2, 13, 22, 25, 32 AND 50).

FIRST USE 4-30-1992; IN COMMERCE 4-30-1992.

CLASS 21—HOUSEWARES AND GLASS

FOR BATHROOM ACCESSORIES, NAMELY, SOAP DISHES, TOOTHBRUSH HOLDERS, WASTEBASKETS, BATHROOM TUMBLERS, LOTION PUMP DISPENSERS SOLD EMPTY, AND TISSUE HOLDERS; BATHROOM ACCESSORIES MADE OF METAL, NAMELY, SOAP DISHES, TOOTHBRUSH HOLDERS, WASTEBASKETS, LOTION PUMP DISPENSERS SOLD EMPTY, TISSUE HOLDERS (U.S. CLS. 2, 13, 23, 29, 30, 33, 40 AND 50).
FIRST USE 4-30-1992; IN COMMERCE 4-30-1992.

CLASS 24—FABRICS

FOR BED LINENS, NAMELY, BED SHEETS, PILLOW CASES, PILLOW SHAMS, BED SKIRTS, DUST RUFFLES, BED BLANKETS, BLANKET TROWS, BEDSPREADS, COMFORTERS, COMFORTER COVERS, DUVETS, DUVET COVERS, QUILTS, AND COVERLETS; BATH TOWELS, HAND TOWELS, AND WASH CLOTHS; FABRIC SHOWER CURTAINS; FABRIC WINDOW TREATMENTS, NAMELY, CURTAINS, CURTAIN TIE-BACKS, DRAPERIES, VALANCES, PANELS, AND SWAGS; KITCHEN LINENS, NAMELY, KITCHEN TOWELS AND DISH CLOTHS; TABLE LINENS, NAMELY, TABLECLOTHS, TABLE RUNNERS, PLACEMATS, AND CLOTH NAPKINS (U.S. CLS. 42 AND 50).
FIRST USE 4-30-1992; IN COMMERCE 4-30-1992.

CLASS 27—FLOOR COVERINGS

FOR RUGS, BATH RUGS, AND BATH MATS (U.S. CLS. 19, 20, 37, 42 AND 50).
FIRST USE 4-30-1992; IN COMMERCE 4-30-1992.

4,016,611. META PHARMACEUTICAL SERVICES, BLUE BELL, PA. SN 77-946,099. PUB. 11-2-2010, FILED 2-26-2010.

RX ACCELERATOR

THE MARK CONSISTS OF STANDARD CHARACTERS WITHOUT CLAIM TO ANY PARTICULAR FONT, STYLE, SIZE, OR COLOR.

NO CLAIM IS MADE TO THE EXCLUSIVE RIGHT TO USE "RX", APART FROM THE MARK AS SHOWN.

CLASS 9—ELECTRICAL AND SCIENTIFIC APPARATUS

FOR COMPUTER SOFTWARE PLATFORMS FOR DATA INPUT AND REPORTING, COMPUTER SOFTWARE AND DOWNLOADABLE SOFTWARE FOR ANALYZING MARKET SHARE USING SPREADSHEETS AND CHARTS AS POPULATED BY INFORMATION IN THE DATABASE IN THE FIELD OF BRANDS AND CUSTOMERS, PROVIDING TARGETED SEGMENTATION TO FACILITATE STRATEGIC BRAND GROWTH, COMPUTER STORAGE DEVICES, NAMELY, HIGH-SPEED STORAGE SUBSYSTEMS FOR STORAGE AND BACKUP OF ELECTRONIC DATA EITHER LOCALLY OR VIA A TELECOMMUNICATIONS NETWORK TO STORE CRUCIAL DATA ELEMENTS ABOUT BRANDS AND CUSTOMERS (U.S. CLS. 21, 23, 26, 36 AND 38).
FIRST USE 3-31-2011; IN COMMERCE 3-31-2011.

CLASS 42—SCIENTIFIC AND COMPUTER SERVICES

FOR PLATFORM AS A SERVICE (PAAS) FEATURING COMPUTER SOFTWARE PLATFORMS FOR ANALYZING MARKET SHARE USING SPREADSHEETS AND CHARTS AS POPULATED BY INFORMATION IN THE DATABASE; RESEARCH ON THE SUBJECT OF PHARMACEUTICALS (U.S. CLS. 100 AND 101).
FIRST USE 3-31-2011; IN COMMERCE 3-31-2011.

4,016,612. THE PRUDENTIAL INSURANCE COMPANY OF AMERICA, NEWARK, NJ. SN 77-946,105. PUB. 10-5-2010, FILED 2-26-2010.



OWNER OF U.S. REG. NOS. 2,321,571, 2,321,573, AND OTHERS.

THE MARK CONSISTS OF A "GLOBE DESIGN" WITH "MERIDIANS" AND "PARALLELS", A "SLANTED E" DESIGN OVERLAYING THE "GLOBE" DESIGN AND INCORPORATING THE WORDS "E. CERTIFIED 2.0", AND A "RING CIRCLING" THE "GLOBE".

CLASS 36—INSURANCE AND FINANCIAL

FOR REAL ESTATE BROKERAGE SERVICES FEATURING REAL ESTATE PROFESSIONALS CERTIFIED IN THE SPECIALIZED USE OF ELECTRONIC TECHNOLOGIES AND ONLINE COMMERCE (U.S. CLS. 100, 101 AND 102).
FIRST USE 10-0-2010; IN COMMERCE 10-0-2010.

CLASS 41—EDUCATION AND ENTERTAINMENT

FOR EDUCATIONAL SERVICES, NAMELY, PROVIDING TRAINING AND CONTINUING INSTRUCTION TO CERTIFY THE PROFICIENCY OF REAL ESTATE PROFESSIONALS IN UTILIZING ELECTRONIC TECHNOLOGY AND ONLINE COMMERCE (U.S. CLS. 100, 101 AND 107).
FIRST USE 10-0-2010; IN COMMERCE 10-0-2010.

4,016,613. META PHARMACEUTICAL SERVICES, BLUE BELL, PA. SN 77-946,142. PUB. 11-23-2010, FILED 2-26-2010.

REPMAIL

THE MARK CONSISTS OF STANDARD CHARACTERS WITHOUT CLAIM TO ANY PARTICULAR FONT, STYLE, SIZE, OR COLOR.

CLASS 9—ELECTRICAL AND SCIENTIFIC APPARATUS

FOR COMPUTER SOFTWARE FOR DRAFTING, EDITING, SENDING AND RECEIVING E-MAIL AND WIRELESS E-MAIL (U.S. CLS. 21, 23, 26, 36 AND 38).
FIRST USE 3-2-2011; IN COMMERCE 3-2-2011.

CLASS 42—SCIENTIFIC AND COMPUTER SERVICES

FOR E-MAIL REPORT GENERATION SYSTEM DESIGN AND IMPLEMENTATION FOR OTHERS (U.S. CLS. 100 AND 101).
FIRST USE 3-2-2011; IN COMMERCE 3-2-2011.

4,016,614. META PHARMACEUTICAL SERVICES, BLUE BELL, PA. SN 77-946,182. PUB. 10-26-2010, FILED 2-26-2010.

FIELD GUIDE

THE MARK CONSISTS OF STANDARD CHARACTERS WITHOUT CLAIM TO ANY PARTICULAR FONT, STYLE, SIZE, OR COLOR.

CLASS 9—ELECTRICAL AND SCIENTIFIC APPARATUS

FOR COMPUTER SOFTWARE PLATFORMS FOR PRODUCING REPORTS RELATED TO CORPORATE PERFORMANCE, SALES, AND BRAND PORTFOLIO MANAGEMENT (U.S. CLS. 21, 23, 26, 36 AND 38).
FIRST USE 4-19-2011; IN COMMERCE 4-19-2011.

CLASS 42—SCIENTIFIC AND COMPUTER SERVICES

FOR PLATFORM AS A SERVICE (PAAS) FEATURING COMPUTER SOFTWARE PLATFORMS FOR PRODUCING REPORTS RELATED TO CORPORATE PERFORMANCE, SALES, AND BRAND PORTFOLIO MANAGEMENT; RESEARCH ON THE SUBJECT OF PHARMACEUTICALS (U.S. CLS. 100 AND 101).
FIRST USE 4-19-2011; IN COMMERCE 4-19-2011.

4,016,615. META PHARMACEUTICAL SERVICES, BLUE BELL, PA. SN 77-946,197. PUB. 10-26-2010, FILED 2-26-2010.

PAYERGUIDE

THE MARK CONSISTS OF STANDARD CHARACTERS WITHOUT CLAIM TO ANY PARTICULAR FONT, STYLE, SIZE, OR COLOR.

CLASS 9—ELECTRICAL AND SCIENTIFIC APPARATUS

FOR COMPUTER SOFTWARE PLATFORMS FOR DATA INPUT AND REPORTING, COMPUTER SOFTWARE AND DOWNLOADABLE SOFTWARE FOR ANALYZING DATA AND BRAND PERFORMANCE USING SPREADSHEETS AND CHARTS AS POPULATED BY INFORMATION IN DATABASE TO HELP WITH COMMERCIAL GROWTH OPPORTUNITIES, SPECIFICALLY RELATED TO MEDICARE PART D, AND FEDERAL ACCOUNTS IN KEY GEOGRAPHIC REGIONS (U.S. CLS. 21, 23, 26, 36 AND 38).
FIRST USE 1-3-2011; IN COMMERCE 1-3-2011.

CLASS 42—SCIENTIFIC AND COMPUTER SERVICES

FOR PLATFORM AS A SERVICE (PAAS) FEATURING COMPUTER SOFTWARE PLATFORMS FOR ANALYZING DATA AND BRAND PERFORMANCE USING SPREADSHEETS AND CHARTS AS POPULATED BY INFORMATION IN DATABASE TO HELP WITH COMMERCIAL GROWTH OPPORTUNITIES, SPECIFICALLY RELATED TO MEDICARE PART D, AND FEDERAL ACCOUNTS IN KEY GEOGRAPHIC REGIONS; RESEARCH ON THE SUBJECT OF PHARMACEUTICALS (U.S. CLS. 100 AND 101).
FIRST USE 1-3-2011; IN COMMERCE 1-3-2011.

4,016,619. META PHARMACEUTICAL SERVICES, BLUE BELL, PA. SN 77-947,193. PUB. 10-26-2010, FILED 3-1-2010.

PROMOREVIEW

THE MARK CONSISTS OF STANDARD CHARACTERS WITHOUT CLAIM TO ANY PARTICULAR FONT, STYLE, SIZE, OR COLOR.

CLASS 9—ELECTRICAL AND SCIENTIFIC APPARATUS

FOR COMPUTER SOFTWARE PLATFORMS FOR RETURN ON INVESTMENT REPORTING, COMPUTER SOFTWARE AND DOWNLOADABLE SOFTWARE FOR ANALYZING DATA AND RETURN ON INVESTMENT USING SPREADSHEETS AND CHARTS AS POPULATED BY INFORMATION IN DATABASE TO HELP ANALYZE AND TRACK CORPORATE PROMOTIONAL ACTIVITIES AND PROFITABILITY, IDENTIFY AND RECOMMEND BEST BUSINESS PRACTICES, AND TO HELP BUSINESSES AVOID COMMON PITFALLS (U.S. CLS. 21, 23, 26, 36 AND 38).
FIRST USE 10-8-2010; IN COMMERCE 10-8-2010.

CLASS 42—SCIENTIFIC AND COMPUTER SERVICES

FOR PLATFORM AS A SERVICE (PAAS) FEATURING COMPUTER SOFTWARE PLATFORMS FOR ANALYZING AND TRACKING CORPORATE PROMOTIONAL ACTIVITIES AND PROFITABILITY, IDENTIFY AND RECOMMEND BEST BUSINESS PRACTICES, AND TO HELP BUSINESSES AVOID COMMON PITFALLS; RESEARCH ON THE SUBJECT OF PHARMACEUTICALS (U.S. CLS. 100 AND 101).
FIRST USE 10-8-2010; IN COMMERCE 10-8-2010.

4,016,628. THE PROCTER & GAMBLE COMPANY, CINCINNATI, OH. SN 77-949,533. PUB. 11-30-2010, FILED 3-3-2010.

4,016,631. NATIONAL ELECTRONICS WARRANTY, LLC, STERLING, VA. SN 77-951,471. PUB. 10-19-2010, FILED 3-5-2010.

MINTY BREEZE

THE MARK CONSISTS OF STANDARD CHARACTERS WITHOUT CLAIM TO ANY PARTICULAR FONT, STYLE, SIZE, OR COLOR.

NO CLAIM IS MADE TO THE EXCLUSIVE RIGHT TO USE "MINTY", APART FROM THE MARK AS SHOWN.

CLASS 3—COSMETICS AND CLEANING PREPARATIONS

FOR TOOTHPASTE (U.S. CLS. 1, 4, 6, 50, 51 AND 52). FIRST USE 8-30-2010; IN COMMERCE 8-30-2010.

CLASS 21—HOUSEWARES AND GLASS

FOR DENTAL FLOSS (U.S. CLS. 2, 13, 23, 29, 30, 33, 40 AND 50). FIRST USE 8-30-2010; IN COMMERCE 8-30-2010.

4,016,629. MARK ANTHONY INTERNATIONAL SRL, ST. MICHAEL, BARBADOS. SN 77-949,720. PUB. 7-27-2010, FILED 3-3-2010.

CALYPSO BAY

THE MARK CONSISTS OF STANDARD CHARACTERS WITHOUT CLAIM TO ANY PARTICULAR FONT, STYLE, SIZE, OR COLOR.

CLASS 32—LIGHT BEVERAGES

FOR FLAVORED BREWED MALT-BASED ALCOHOLIC BEVERAGES IN THE NATURE OF BEER (U.S. CLS. 45, 46 AND 48). FIRST USE 4-17-2011; IN COMMERCE 4-17-2011.

CLASS 33—WINES AND SPIRITS

FOR ALCOHOLIC FLAVORED MALT COOLERS (U.S. CLS. 47 AND 49). FIRST USE 4-17-2011; IN COMMERCE 4-17-2011.

SERVICE VALET

THE MARK CONSISTS OF STANDARD CHARACTERS WITHOUT CLAIM TO ANY PARTICULAR FONT, STYLE, SIZE, OR COLOR.

NO CLAIM IS MADE TO THE EXCLUSIVE RIGHT TO USE "SERVICE", APART FROM THE MARK AS SHOWN.

CLASS 35—ADVERTISING AND BUSINESS

FOR ONLINE AND TELEPHONIC SCHEDULING OF SERVICE, REPAIR, MAINTENANCE, DELIVERY AND INSTALLATION OF CONSUMER, HOUSEHOLD, AND COMMERCIAL APPLIANCES, CONSUMER ELECTRONICS, COMPUTERS, HOME THEATERS, AUTOMOBILE ELECTRONIC PRODUCTS, CELL PHONES, PDAS, OUTDOOR POWER EQUIPMENT, EXERCISE AND RECREATION EQUIPMENT, HOME FURNISHINGS, TOYS, HOUSEHOLD PRODUCTS AND SYSTEMS INCLUDING HVAC, PLUMBING, ELECTRICAL, AND LAWN AND GARDEN PRODUCTS AND SYSTEMS; ADMINISTRATION OF A PROGRAM FOR ENABLING PARTICIPANTS TO OBTAIN DISCOUNTS ON THE COST OF PRODUCT DIAGNOSTIC AND REPAIR SERVICES OR RECEIVE IMPROVED LEVELS OF SERVICE; PROVIDING PRODUCT INFORMATION TO CONSUMERS VIA THE INTERNET REGARDING CONSUMER, HOUSEHOLD, AND COMMERCIAL APPLIANCES, CONSUMER ELECTRONICS, COMPUTERS, HOME THEATERS, AUTOMOBILE ELECTRONIC PRODUCTS, CELL PHONES, PDAS, OUTDOOR POWER EQUIPMENT, EXERCISE AND RECREATION EQUIPMENT, HOME FURNISHINGS, TOYS, HOUSEHOLD PRODUCTS AND SYSTEMS INCLUDING HVAC, PLUMBING, ELECTRICAL, AND LAWN AND GARDEN PRODUCTS AND SYSTEMS (U.S. CLS. 100, 101 AND 102).

FIRST USE 8-0-2010; IN COMMERCE 8-0-2010.

CLASS 36—INSURANCE AND FINANCIAL

FOR ADMINISTRATION OF WARRANTY SERVICES AND REPAIR SERVICE CONTRACTS, NAMELY, PROCESSING WARRANTY CLAIMS FOR CONSUMER, HOUSEHOLD, AND COMMERCIAL APPLIANCES, CONSUMER ELECTRONICS, COMPUTERS, HOME THEATERS, AUTOMOBILE ELECTRONIC PRODUCTS, CELL PHONES, PDAS, OUTDOOR POWER EQUIPMENT, EXERCISE AND RECREATION EQUIPMENT, HOME FURNISHINGS, TOYS, HOUSEHOLD PRODUCTS AND SYSTEMS INCLUDING HVAC, PLUMBING, ELECTRICAL, AND LAWN AND GARDEN PRODUCTS AND SYSTEMS; PROVIDING EXTENDED WARRANTIES IN THE FIELD OF CONSUMER, HOUSEHOLD, AND COMMERCIAL APPLIANCES, CONSUMER ELECTRONICS, COMPUTERS, HOME THEATERS, AUTOMOBILE ELECTRONIC PRODUCTS, CELL PHONES, PDAS, OUTDOOR POWER EQUIPMENT, EXERCISE AND RECREATION EQUIPMENT, HOME FURNISHINGS, TOYS, HOUSEHOLD PRODUCTS AND SYSTEMS INCLUDING HVAC, PLUMBING, ELECTRICAL, AND LAWN AND GARDEN PRODUCTS AND SYSTEMS (U.S. CLS. 100, 101 AND 102).

FIRST USE 5-16-2011; IN COMMERCE 5-16-2011.

CLASS 37—CONSTRUCTION AND REPAIR

FOR TECHNICAL SUPPORT SERVICES, NAMELY, TROUBLESHOOTING IN THE NATURE OF THE REPAIR OF COMPUTER HARDWARE, CONSUMER, HOUSEHOLD, AND COMMERCIAL APPLIANCES, CONSUMER ELECTRONICS, COMPUTERS, HOME THEATERS, AUTOMOBILE ELECTRONIC PRODUCTS, CELL PHONES, PDAS, OUTDOOR POWER EQUIPMENT, EXERCISE AND RECREATION EQUIPMENT, HOME FURNISHINGS, TOYS, HOUSEHOLD PRODUCTS AND SYSTEMS INCLUDING HVAC, PLUMBING, ELECTRICAL, AND LAWN AND GARDEN PRODUCTS AND SYSTEMS (U.S. CLS. 100, 103 AND 106).

FIRST USE 8-0-2010; IN COMMERCE 8-0-2010.

CLASS 41—EDUCATION AND ENTERTAINMENT

FOR PROVIDING ONLINE PUBLICATIONS, NAMELY, PRODUCT MANUALS, SET-UP GUIDES, AND ARTICLES TO CONSUMERS VIA THE INTERNET REGARDING CONSUMER, HOUSEHOLD, AND COMMERCIAL APPLIANCES, CONSUMER ELECTRONICS, COMPUTERS, HOME THEATERS, AUTOMOBILE ELECTRONIC PRODUCTS, CELL PHONES, PDAS, OUTDOOR POWER EQUIPMENT, EXERCISE AND RECREATION EQUIPMENT, HOME FURNISHINGS, TOYS, HOUSEHOLD PRODUCTS AND SYSTEMS INCLUDING HVAC, PLUMBING, ELECTRICAL, AND LAWN AND GARDEN PRODUCTS AND SYSTEMS (U.S. CLS. 100, 101 AND 107).

FIRST USE 8-0-2010; IN COMMERCE 8-0-2010.

CLASS 42—SCIENTIFIC AND COMPUTER SERVICES

FOR INSTALLATION, MAINTENANCE AND REPAIR OF COMPUTER SOFTWARE (U.S. CLS. 100 AND 101).

FIRST USE 8-0-2010; IN COMMERCE 8-0-2010.

4,016,635. ADVANCE MAGAZINE PUBLISHERS INC., NEW YORK, NY. SN 77-954,168. PUB. 11-23-2010, FILED 3-9-2010.

LUCKY SHOPS BOUTIQUES

THE MARK CONSISTS OF STANDARD CHARACTERS WITHOUT CLAIM TO ANY PARTICULAR FONT, STYLE, SIZE, OR COLOR.

OWNER OF U.S. REG. NOS. 2,469,245, 2,781,524, AND 2,953,777.

NO CLAIM IS MADE TO THE EXCLUSIVE RIGHT TO USE "SHOPS BOUTIQUES", APART FROM THE MARK AS SHOWN.

CLASS 35—ADVERTISING AND BUSINESS

FOR ORGANIZING, CONDUCTING AND HOSTING SHOPPING EVENTS FOR OTHERS FOR COMMERCIAL, PROMOTIONAL, OR ADVERTISING PURPOSES, PROVIDING INFORMATION ABOUT SHOPPING (U.S. CLS. 100, 101 AND 102).

FIRST USE 9-0-2009; IN COMMERCE 9-0-2009.

CLASS 41—EDUCATION AND ENTERTAINMENT

FOR ORGANIZING, CONDUCTING AND HOSTING SOCIAL EVENTS AND SHOPPING EVENTS FOR RECREATIONAL PURPOSES AND ENTERTAINMENT PURPOSES (U.S. CLS. 100, 101 AND 107).

FIRST USE 9-0-2009; IN COMMERCE 9-0-2009.

CLASS 45—PERSONAL AND LEGAL SERVICES

FOR PERSONAL SHOPPING SERVICES FOR OTHERS, PROVIDING INFORMATION ABOUT STYLE AND FASHION (U.S. CLS. 100 AND 101).

FIRST USE 9-0-2009; IN COMMERCE 9-0-2009.

4,016,636. ROYAL PAPER PRODUCTS, INC., COATESVILLE, PA. SN 77-955,456. PUB. 4-19-2011, FILED 3-10-2010.

ZIP-IT

THE MARK CONSISTS OF STANDARD CHARACTERS WITHOUT CLAIM TO ANY PARTICULAR FONT, STYLE, SIZE, OR COLOR.

CLASS 3—COSMETICS AND CLEANING PREPARATIONS

FOR NON-ELECTRIC DEEP FRYER AND GRILL CLEANER, NAMELY, A CONCENTRATED BLEND OF ALKALIS AND PHOSPHATE CLEANING PREPARATION (U.S. CLS. 1, 4, 6, 50, 51 AND 52).

FIRST USE 2-9-2011; IN COMMERCE 2-9-2011.

CLASS 8—HAND TOOLS

FOR DISPOSABLE TABLEWARE, NAMELY, FORKS, KNIVES AND SPOONS (U.S. CLS. 23, 28 AND 44).

FIRST USE 2-9-2011; IN COMMERCE 2-9-2011.

CLASS 20—FURNITURE AND ARTICLES NOT OTHERWISE CLASSIFIED

FOR GLOVE DISPENSERS, NOT MADE OF METAL; NON-METAL DISPENSERS FOR HEADWARE AND HAIR RESTRAINTS; COASTER DISPENSERS BEING NON-METAL; SPIRIT-FILLED MESSAGE TABLE COVERS; PLASTIC PIZZA SAVERS, NAMELY, A DEVICE THAT IS INSERTED ON THE TOP OF A PIZZA TO PROTECT THE CHEESE FROM MELTING ON THE PIZZA BOX; COMMERCIAL FOOD PACKAGING MATERIALS, NAMELY, PACKAGING PLASTIC BASKETS AND RIGID PLASTIC TRAYS FOR FOOD; WOODEN AND PLASTIC PICKS FOR USE WITH FOODS, NAMELY, LONG PICKS FOR USE WITH APPETIZERS, BEVERAGES, AND SANDWICHES; WOODEN AND PLASTIC MINIATURE PARASOLS USED AS DECORATIONS FOR BEVERAGES AND FOODS; STEAK MARKERS, MADE OF PLASTIC, TO IDENTIFY HOW THE STEAK IS COOKED; WOODEN AND PLASTIC DRINKING STRAWS; NON-METAL CONTAINERS FOR COMMERCIAL USE; BAG RACKS, NAMELY, RACKS FOR HOLDING PLASTIC BAGS FOR COMMERCIAL USE (U.S. CLS. 2, 13, 22, 25, 32 AND 50).

FIRST USE 2-9-2011; IN COMMERCE 2-9-2011.

CLASS 21—HOUSEWARES AND GLASS

FOR BAG RACKS, NAMELY, RACKS FOR HOLDING PLASTIC BAGS DOMESTIC USE; CHOPSTICKS; DISPOSABLE DINNERWARE AND TABLEWARE, NAMELY, DISHES, BOWLS, PLATES, CUPS AND DRINKING VESSELS; DISPOSABLE SERVING TRAYS, DISPOSABLE HOUSEHOLD USE FOOD TRAYS; DISPOSABLE SERVING WARE FOR SERVING FOOD; SERVING TRAYS FOR THE SERVICE OF FOOD AND LIDS THEREFOR SOLD TOGETHER AS A UNIT; DISPOSABLE COOKING PANS; NON-ELECTRIC DISPOSABLE COOKING VESSELS, NAMELY, PANS, ROASTERS, AND BROILERS; NON-ELECTRIC DISPOSABLE KITCHENWARE, NAMELY, PANS; PAPER BAKING CUPS; PAPER ÉCLAIR CUPS; VINYL BASKETS, NAMELY, BASKETS DESIGNED TO HOLD FOOD; SCOURING PADS AND SPONGES FOR CLEANING; COOKING SKEWERS; WOODEN AND PLASTIC DRINK STIRRERS; DISPOSABLE GLOVES FOR HOME USE; PLASTIC COASTERS; FOOD SHELLS, NAMELY, DISPOSABLE COOKING AND SERVING DISHES IN THE SHAPE OF VARIOUS FOODS; GRILL BRICKS, CLEANING PADS AND SCREENS, NAMELY, BRICKS, NYLON PADS, AND SCREENS FOR THE PURPOSE OF CLEANING A GRILL (U.S. CLS. 2, 13, 23, 29, 30, 33, 40 AND 50).

FIRST USE 2-9-2011; IN COMMERCE 2-9-2011.

CLASS 26—FANCY GOODS

FOR PAPER, PLASTIC AND MESH HEADWEAR USED FOR SANITARY PROTECTION, NAMELY, HAIR NETS AND HAIR NETTING (U.S. CLS. 37, 39, 40, 42 AND 50).

FIRST USE 2-9-2011; IN COMMERCE 2-9-2011.

CLASS 20—FURNITURE AND ARTICLES NOT OTHERWISE CLASSIFIED

FOR GLOVE DISPENSERS, NOT MADE OF METAL; NON-METAL DISPENSERS FOR HEADWARE AND HAIR RESTRAINTS; COASTER DISPENSERS BEING NON-METAL; SPIRIT-FILLED MESSAGE TABLE COVERS; PLASTIC PIZZA SAVERS, NAMELY, A DEVICE THAT IS INSERTED ON THE TOP OF A PIZZA TO PROTECT THE CHEESE FROM MELTING ON THE PIZZA BOX; COMMERCIAL FOOD PACKAGING MATERIALS, NAMELY, PACKAGING PLASTIC BASKETS AND RIGID PLASTIC TRAYS FOR FOOD; WOODEN AND PLASTIC PICKS FOR USE WITH FOODS, NAMELY, LONG PICKS FOR USE WITH APPETIZERS, BEVERAGES, AND SANDWICHES; WOODEN AND PLASTIC MINIATURE PARASOLS USED AS DECORATIONS FOR BEVERAGES AND FOODS; STEAK MARKERS, MADE OF PLASTIC, TO IDENTIFY HOW THE STEAK IS COOKED; WOODEN AND PLASTIC DRINKING STRAWS; NON-METAL CONTAINERS FOR COMMERCIAL USE; BAG RACKS, NAMELY, RACKS FOR HOLDING PLASTIC BAGS FOR COMMERCIAL USE (U.S. CLS. 2, 13, 22, 25, 32 AND 50).

FIRST USE 2-9-2011; IN COMMERCE 2-9-2011.

CLASS 21—HOUSEWARES AND GLASS

FOR BAG RACKS, NAMELY, RACKS FOR HOLDING PLASTIC BAGS DOMESTIC USE; CHOPSTICKS; DISPOSABLE DINNERWARE AND TABLEWARE, NAMELY, DISHES, BOWLS, PLATES, CUPS AND DRINKING VESSELS; DISPOSABLE SERVING TRAYS, DISPOSABLE HOUSEHOLD USE FOOD TRAYS; DISPOSABLE SERVING WARE FOR SERVING FOOD; SERVING TRAYS FOR THE SERVICE OF FOOD AND LIDS THEREFOR SOLD TOGETHER AS A UNIT; DISPOSABLE COOKING PANS; NON-ELECTRIC DISPOSABLE COOKING VESSELS, NAMELY, PANS, ROASTERS, AND BROILERS; NON-ELECTRIC DISPOSABLE KITCHENWARE, NAMELY, PANS; PAPER BAKING CUPS; PAPER ÉCLAIR CUPS; VINYL BASKETS, NAMELY, BASKETS DESIGNED TO HOLD FOOD; SCOURING PADS AND SPONGES FOR CLEANING; COOKING SKEWERS; WOODEN AND PLASTIC DRINK STIRRERS; DISPOSABLE GLOVES FOR HOME USE; PLASTIC COASTERS; FOOD SHELLS, NAMELY, DISPOSABLE COOKING AND SERVING DISHES IN THE SHAPE OF VARIOUS FOODS; GRILL BRICKS, CLEANING PADS AND SCREENS, NAMELY, BRICKS, NYLON PADS, AND SCREENS FOR THE PURPOSE OF CLEANING A GRILL (U.S. CLS. 2, 13, 23, 29, 30, 33, 40 AND 50).

FIRST USE 2-9-2011; IN COMMERCE 2-9-2011.

CLASS 26—FANCY GOODS

FOR PAPER, PLASTIC AND MESH HEADWEAR USED FOR SANITARY PROTECTION, NAMELY, HAIR NETS AND HAIR NETTING (U.S. CLS. 37, 39, 40, 42 AND 50).

FIRST USE 2-9-2011; IN COMMERCE 2-9-2011.

4,016,637. ROYAL PAPER PRODUCTS, INC., COATESVILLE, PA. SN 77-955,486. PUB. 4-19-2011, FILED 3-10-2010.

ZIP-IT BY ROYAL

THE MARK CONSISTS OF STANDARD CHARACTERS WITHOUT CLAIM TO ANY PARTICULAR FONT, STYLE, SIZE, OR COLOR.

CLASS 3—COSMETICS AND CLEANING PREPARATIONS

FOR NON-ELECTRIC DEEP FRYER AND GRILL CLEANER, NAMELY, A CONCENTRATED BLEND OF ALKALIS AND PHOSPHATE CLEANING PREPARATION (U.S. CLS. 1, 4, 6, 50, 51 AND 52).

FIRST USE 2-9-2011; IN COMMERCE 2-9-2011.

CLASS 8—HAND TOOLS

FOR DISPOSABLE TABLEWARE, NAMELY, FORKS, KNIVES AND SPOONS (U.S. CLS. 23, 28 AND 44).

FIRST USE 2-9-2011; IN COMMERCE 2-9-2011.

4,016,643. LF, LLC, MOUNT MOURNE, NC. SN 77-957,901. PUB. 12-7-2010, FILED 3-12-2010.

**CREATIVE IDEAS FOR
WOODWORKERS**

THE MARK CONSISTS OF STANDARD CHARACTERS WITHOUT CLAIM TO ANY PARTICULAR FONT, STYLE, SIZE, OR COLOR.

NO CLAIM IS MADE TO THE EXCLUSIVE RIGHT TO USE "WOODWORKERS", APART FROM THE MARK AS SHOWN.

CLASS 35—ADVERTISING AND BUSINESS

FOR RETAIL STORE SERVICES FEATURING A VARIETY OF APPLIANCES, BUILDING MATERIALS, LIGHTING AND ELECTRICAL SUPPLIES, PLUMBING SUPPLIES, LAWN AND GARDEN SUPPLIES, ROOFING MATERIALS, PAINT AND PAINTING SUPPLIES, HOME FURNISHINGS AND HOME IMPROVEMENT SUPPLIES (U.S. CLS. 100, 101 AND 102).
FIRST USE 3-15-2008; IN COMMERCE 3-15-2008.

CLASS 40—MATERIAL TREATMENT

FOR PROVIDING INFORMATION IN THE FIELD OF WOODWORKING PROJECTS, WOODWORKING TOOLS AND WOODWORKING MATERIALS VIA THE INTERNET (U.S. CLS. 100, 103 AND 106).
FIRST USE 3-15-2008; IN COMMERCE 3-15-2008.

CLASS 41—EDUCATION AND ENTERTAINMENT

FOR EDUCATIONAL SERVICES, NAMELY, CONDUCTING ONLINE INSTRUCTION IN THE FIELD OF WOODWORKING PROJECTS (U.S. CLS. 100, 101 AND 107).
FIRST USE 3-15-2008; IN COMMERCE 3-15-2008.

4,016,648. THE SAINT AUGUSTINE LIGHTHOUSE AND MUSEUM, INC., ST. AUGUSTINE, FL. SN 77-959,702. PUB. 11-16-2010, FILED 3-16-2010.

FIRST LIGHT MARITIME SOCIETY

THE MARK CONSISTS OF STANDARD CHARACTERS WITHOUT CLAIM TO ANY PARTICULAR FONT, STYLE, SIZE, OR COLOR.

NO CLAIM IS MADE TO THE EXCLUSIVE RIGHT TO USE "MARITIME SOCIETY", APART FROM THE MARK AS SHOWN.

CLASS 35—ADVERTISING AND BUSINESS

FOR ADMINISTRATION OF A PROGRAM FOR ENABLING PARTICIPANTS TO OBTAIN DISCOUNTS ON PRODUCTS AND SERVICES (U.S. CLS. 100, 101 AND 102).
FIRST USE 7-6-2011; IN COMMERCE 7-6-2011.

CLASS 41—EDUCATION AND ENTERTAINMENT

FOR PROVIDING INFORMATION IN THE FIELD OF FLORIDA HISTORY, NAMELY, MARITIME HISTORY, ARCHEOLOGY, AND HISTORIC SHIP-BUILDING (U.S. CLS. 100, 101 AND 107).
FIRST USE 7-6-2011; IN COMMERCE 7-6-2011.

4,016,669. EXLSERVICE HOLDINGS, INC., NEW YORK, NY. SN 77-981,085. PUB. 4-28-2009, FILED 3-28-2008.

GO NEXT. NOW.

THE MARK CONSISTS OF STANDARD CHARACTERS WITHOUT CLAIM TO ANY PARTICULAR FONT, STYLE, SIZE, OR COLOR.

CLASS 35—ADVERTISING AND BUSINESS

FOR BUSINESS PROCESS OUTSOURCING AND KNOWLEDGE PROCESS OUTSOURCING IN THE FIELDS OF INSURANCE, BANKING, FINANCIAL SERVICES, HEALTH CARE, SECURITIES, TELECOMMUNICATIONS, CREDIT CARD ADMINISTRATION, HUMAN RESOURCES, ACCOUNTING, PUBLIC UTILITIES, ADVERTISING AND NEWS REPORTING, AND LEGAL SERVICES; CONSULTING AND ADVISORY SERVICES IN THE FIELDS OF PROVIDING BUSINESS INFORMATION FOR ENTERPRISES, HUMAN RESOURCES, ACCOUNTING, AND BUSINESS MANAGEMENT PROFESSIONAL SERVICES (U.S. CLS. 100, 101 AND 102).
FIRST USE 5-21-2009; IN COMMERCE 5-21-2009.

CLASS 36—INSURANCE AND FINANCIAL

FOR CONSULTING AND ADVISORY SERVICES, IN THE FIELDS OF INSURANCE, HEALTH CARE INSURANCE, BANKING, AND FINANCIAL SERVICES (U.S. CLS. 100, 101 AND 102).
FIRST USE 5-21-2009; IN COMMERCE 5-21-2009.

CLASS 39—TRANSPORTATION AND STORAGE

FOR CONSULTING AND ADVISORY SERVICES IN THE FIELD OF PUBLIC UTILITIES (U.S. CLS. 100 AND 105).
FIRST USE 5-21-2009; IN COMMERCE 5-21-2009.

CLASS 45—PERSONAL AND LEGAL SERVICES

FOR CONSULTING AND ADVISORY SERVICES IN THE FIELD OF FRAUD DETECTION SERVICES IN THE FIELD OF CREDIT CARDS FOR ON-LINE PURCHASING (U.S. CLS. 100 AND 101).
FIRST USE 5-21-2009; IN COMMERCE 5-21-2009.

4,016,670. RHINO LININGS USA, INC., SAN DIEGO, CA. SN 77-981,223. PUB. 4-27-2010, FILED 3-26-2007.



OWNER OF U.S. REG. NOS. 1,612,373, 2,752,078, AND OTHERS.

THE MARK CONSISTS OF A SILHOUETTE OF A SEGMENTED RHINOCEROS WITHIN A PARALLELOGRAM IN HELVETICA NEW BLACK OBLIQUE FONT.

CLASS 2—PAINTS

FOR SPRAY-ON POLYURETHANE COATING TO PROTECT SURFACES AGAINST CORROSION AND IMPACT FOR APPLICATION ON COMMERCIAL, INDUSTRIAL AND CONSUMER PRODUCTS, NAMELY, VEHICLE TRAILERS, VAN FLOORS, BUILDINGS, SIDEWALKS, COMMERCIAL EQUIPMENT, TRUCK BEDS, FURNITURE, SHELVING AND CABINERY (U.S. CLS. 6, 11 AND 16).

FIRST USE 12-31-2008; IN COMMERCE 12-31-2008.

CLASS 40—MATERIAL TREATMENT

FOR APPLYING PROTECTIVE POLYURETHANE COATING TO COMMERCIAL, INDUSTRIAL AND CONSUMER PRODUCTS, NAMELY, VEHICLE TRAILERS, VAN FLOORS, BUILDINGS, SIDEWALKS, COMMERCIAL EQUIPMENT, TRUCK BEDS, FURNITURE, SHELVING AND CABINERY (U.S. CLS. 100, 103 AND 106).

FIRST USE 3-16-2007; IN COMMERCE 3-16-2007.

4,016,674. JASON KATIMS, NEW YORK, NY. SN 77-982,037.
PUB. 9-14-2010, FILED 2-1-2010.

TRUE JACK PRODUCTIONS

THE MARK CONSISTS OF STANDARD CHARACTERS WITHOUT CLAIM TO ANY PARTICULAR FONT, STYLE, SIZE, OR COLOR.

NO CLAIM IS MADE TO THE EXCLUSIVE RIGHT TO USE "PRODUCTIONS", APART FROM THE MARK AS SHOWN.

CLASS 38—COMMUNICATION

FOR STREAMING OF AUDIO AND VIDEO MATERIAL ON THE INTERNET (U.S. CLS. 100, 101 AND 104).

FIRST USE 3-2-2010; IN COMMERCE 3-2-2010.

CLASS 41—EDUCATION AND ENTERTAINMENT

FOR PRODUCTION OF TELEVISION PROGRAMS (U.S. CLS. 100, 101 AND 107).

FIRST USE 3-2-2010; IN COMMERCE 3-2-2010.

4,016,678. ALTE POWERTRAIN TECHNOLOGIES, AUBURN HILLS, MI. SN 77-982,102. PUB. 9-14-2010, FILED 3-24-2010.

Make the shift

THE MARK CONSISTS OF STANDARD CHARACTERS WITHOUT CLAIM TO ANY PARTICULAR FONT, STYLE, SIZE, OR COLOR.

CLASS 40—MATERIAL TREATMENT

FOR CUSTOM MANUFACTURE OF ELECTRIC POWERTRAINS FOR VEHICLES (U.S. CLS. 100, 103 AND 106).

FIRST USE 3-7-2011; IN COMMERCE 3-7-2011.

CLASS 42—SCIENTIFIC AND COMPUTER SERVICES

FOR DESIGN AND DEVELOPMENT OF ELECTRIC POWERTRAINS FOR VEHICLES (U.S. CLS. 100 AND 101).

FIRST USE 3-2-2010; IN COMMERCE 3-2-2010.

4,016,681. TARGET BRANDS, INC., MINNEAPOLIS, MN. SN 77-982,114. PUB. 2-23-2010, FILED 10-8-2009.



OWNER OF U.S. REG. NO. 2,836,597.

THE MARK CONSISTS OF THE WORD "EMBARK" IN A STYLIZED FONT, INSIDE A RECTANGLE WITH A TRIANGULAR-NOTCH TAKEN OUT OF THE RIGHT SIDE.

CLASS 6—METAL GOODS

FOR METAL LOCKS FOR TRAVEL; OUTDOOR EQUIPMENT AND ACCESSORIES, NAMELY, METAL TENT POLES, PEGS AND STAKES (U.S. CLS. 2, 12, 13, 14, 23, 25 AND 50).

FIRST USE 3-0-2009; IN COMMERCE 3-0-2009.

CLASS 7—MACHINERY

FOR OUTDOOR EQUIPMENT AND ACCESSORIES, NAMELY, ELECTRIC PUMPS (U.S. CLS. 13, 19, 21, 23, 31, 34 AND 35).

FIRST USE 1-0-2010; IN COMMERCE 1-0-2010.

CLASS 9—ELECTRICAL AND SCIENTIFIC APPARATUS

FOR TRAVEL ACCESSORIES, NAMELY, ADAPTERS, ADAPTER PLUGS, EAR PLUGS FOR SOUNDPROOFING AND SCALES FOR WEIGHING TRAVEL LUGGAGE (U.S. CLS. 21, 23, 26, 36 AND 38).

FIRST USE 3-0-2009; IN COMMERCE 3-0-2009.

CLASS 11—ENVIRONMENTAL CONTROL APPARATUS

FOR SPORTING GOODS AND ACCESSORIES, NAMELY, FLASHLIGHTS, LANTERNS AND PORTABLE PROPANE STOVES FOR OUTDOOR USE (U.S. CLS. 13, 21, 23, 31 AND 34).

FIRST USE 1-0-2010; IN COMMERCE 1-0-2010.

CLASS 14—JEWELRY

FOR ALARM CLOCKS FOR TRAVEL (U.S. CLS. 2, 27, 28 AND 50).

FIRST USE 3-0-2009; IN COMMERCE 3-0-2009.

CLASS 16—PAPER GOODS AND PRINTED MATTER

FOR DOCUMENT HOLDERS FOR TRAVEL (U.S. CLS. 2, 5, 22, 23, 29, 37, 38 AND 50).

FIRST USE 3-0-2009; IN COMMERCE 3-0-2009.

CLASS 18—LEATHER GOODS

FOR LUGGAGE, NAMELY, ROLLING ORGANIZERS, GARMENT BAGS, DUFFEL BAGS, ROLLING DUFFEL BAGS AND ROLLING PILOT CASES; TRAVEL ACCESSORIES, NAMELY, ALL-PURPOSE CARRYING BAGS, ATTACHE CASES, BELT BAGS, CARRYALLS, CARRYING CASES FOR DOCUMENTS, NON-MOTORIZED COLLAPSIBLE LUGGAGE CARTS, LUGGAGE TAGS, SHOE BAGS, STRAPS FOR LUGGAGE, TOILETRY BAGS AND CASES SOLD EMPTY, TRAVEL BAGS AND CASES; BACKPACKS; SATCHELS; CARD WALLETS; CREDIT CARD CASES; HIP BAGS; KEY CASES; WALLETS; CHANGE PURSES; COSMETIC BAGS AND CASES SOLD EMPTY; VANITY CASES SOLD EMPTY; UMBRELLAS AND PARASOLS (U.S. CLS. 1, 2, 3, 22 AND 41).
FIRST USE 2-0-2009; IN COMMERCE 2-0-2009.

CLASS 20—FURNITURE AND ARTICLES NOT OTHERWISE CLASSIFIED

FOR OUTDOOR EQUIPMENT AND ACCESSORIES, NAMELY, CAMPING FURNITURE, OUTDOOR FURNITURE, INFLATABLE MATTRESSES FOR USE WHEN CAMPING, NON METAL TENT PEGS, POLES AND STAKES, SLEEPING BAGS, SLEEPING BAG LINERS AND SLEEPING MATS; TRAVEL ACCESSORIES, NAMELY, INFLATABLE PILLOWS, PILLOWS, NECK SUPPORTING PILLOWS AND NON-METAL LOCKS; OUTDOOR EQUIPMENT AND ACCESSORIES, NAMELY, AIR MATTRESS FOR USE WHEN CAMPING (U.S. CLS. 2, 13, 22, 25, 32 AND 50).
FIRST USE 1-0-2009; IN COMMERCE 1-0-2009.

CLASS 21—HOUSEWARES AND GLASS

FOR OUTDOOR EQUIPMENT AND ACCESSORIES, NAMELY, BEVERAGeware, BOTTLES SOLD EMPTY, ALL PURPOSE PORTABLE HOUSEHOLD CONTAINERS, CAMPING GRILLS, CANTEENS, CONTAINERS FOR ICE, COOKING SKEWERS, DRINKING FLASK SOLD EMPTY AND PORTABLE COOLERS; PORTABLE COOKING KITS FOR OUTDOOR USE; INSULATED BAGS FOR FOOD AND BEVERAGES FOR DOMESTIC USE; THERMAL INSULATED CONTAINERS FOR FOOD OR BEVERAGE (U.S. CLS. 2, 13, 23, 29, 30, 33, 40 AND 50).
FIRST USE 2-0-2009; IN COMMERCE 2-0-2009.

CLASS 22—CORDAGE AND FIBERS

FOR OUTDOOR EQUIPMENT AND ACCESSORIES, NAMELY, CANVAS CANOPIES, HAMMOCKS, TENTS AND TENT FLIES (U.S. CLS. 1, 2, 7, 19, 22, 42 AND 50).
FIRST USE 1-0-2010; IN COMMERCE 1-0-2010.

CLASS 24—FABRICS

FOR TRAVEL ACCESSORIES, NAMELY, BLANKETS, PILLOW COVERS AND PLASTIC PLACE MATS (U.S. CLS. 42 AND 50).
FIRST USE 2-0-2009; IN COMMERCE 2-0-2009.

CLASS 28—TOYS AND SPORTING GOODS

FOR SPORTING GOODS AND ACCESSORIES, NAMELY, BAGS SPECIALLY ADAPTED FOR SPORTS EQUIPMENT, NEEDLES FOR PUMPS FOR INFLATING SPORTS EQUIPMENT, PUMPS FOR INFLATING SPORTS EQUIPMENT, NAMELY, FOOTBALLS, SOCCER BALLS, BASKETBALLS, VOLLEY BALLS, MEDICINE BALLS, SPORT BALLS TETHER BALLS AND RUBBER BALLS; EXERCISE EQUIPMENT, NAMELY, DUMBBELLS, EXERCISE BALLS, EXERCISE BANDS, EXERCISE BARS, PERSONAL EXERCISE MATS, EXERCISE WEIGHTS, EXERCISE WHEELS, JUMP ROPES, STRESS RELIEF BALLS FOR HAND EXERCISE, MEDICINE BALLS, MANUALLY OPERATED EXERCISE EQUIPMENT, RESISTANCE BANDS, SPRING GRIPS FOR HAND EXERCISE, SPRING BARS AND YOGA MATS (U.S. CLS. 22, 23, 38 AND 50).
FIRST USE 8-0-2009; IN COMMERCE 8-0-2009.

4,016,683. ETCHEGARAY FARMS, LLC, VISALIA, CA. SN 77-982,125. PUB. 9-25-2007, FILED 9-23-2006.



OWNER OF U.S. REG. NO. 2,042,707.

THE MARK CONSISTS OF THE WORD "SUNMET", STYLIZED TO CREATE A SHADOW EFFECT, PLACED ABOVE A SEMI-CIRCLE STYLIZED SO AS TO APPEAR TO BE A SUNBURST.

CLASS 29—MEATS AND PROCESSED FOODS

FOR PROCESSED NUTS, NAMELY, DEHYDRATED, VACUUM-PACKED, SLICED AND DICED, ALMONDS AND PISTACHIO NUTS (U.S. CL. 46).
FIRST USE 5-27-2011; IN COMMERCE 5-27-2011.

CLASS 32—LIGHT BEVERAGES

FOR LIGHT BEVERAGES, NAMELY, JUICE CONCENTRATES AND SINGLE-STRENGTH JUICES FROM FRUITS (EXCLUDING THOSE CONTAINING RAISIN, GRAPE, OR PRUNE JUICE) (U.S. CLS. 45, 46 AND 48).
FIRST USE 4-25-2011; IN COMMERCE 4-25-2011.

4,016,689. ZENO CORPORATION, HOUSTON, TX. SN 77-982,151. PUB. 4-13-2010, FILED 7-17-2009.

Beauty Through the Science of Heat

THE MARK CONSISTS OF STANDARD CHARACTERS WITHOUT CLAIM TO ANY PARTICULAR FONT, STYLE, SIZE, OR COLOR.

CLASS 10—MEDICAL APPARATUS

FOR MEDICAL DEVICES FOR ELECTRONIC APPLICATION OF HEAT FOR THE TREATMENT OF BACTERIAL, VIRAL AND FUNGAL INFECTIONS AND ASSOCIATED DISEASES (U.S. CLS. 26, 39 AND 44).
FIRST USE 12-14-2009; IN COMMERCE 12-14-2009.

CLASS 44—MEDICAL, BEAUTY AND AGRICULTURAL SERVICES

FOR PROVIDING MEDICAL INFORMATION ABOUT THE TREATMENT OF SKIN CONDITIONS (U.S. CLS. 100 AND 101).
FIRST USE 12-14-2009; IN COMMERCE 12-14-2009.

4,016,690. ETCHEGARAY FARMS, LLC, VISALIA, CA. SN 77-982,154. PUB. 9-25-2007, FILED 9-23-2006.



OWNER OF U.S. REG. NO. 2,042,707.
THE MARK CONSISTS OF THE WORD "SUNMET", STYLIZED TO CREATE A SHADOW EFFECT, PLACED WITHIN A SEMI-CIRCLE STYLIZED SO AS TO APPEAR TO BE A SUNBURST.

CLASS 29—MEATS AND PROCESSED FOODS

FOR PROCESSED NUTS, NAMELY, DEHYDRATED, VACUUM-PACKED, SLICED AND DICED, ALMONDS AND PISTACHIO NUTS (U.S. CL. 46).
FIRST USE 5-27-2011; IN COMMERCE 5-27-2011.

CLASS 32—LIGHT BEVERAGES

FOR LIGHT BEVERAGES, NAMELY, JUICE CONCENTRATES AND SINGLE-STRENGTH JUICES FROM FRUITS (EXCLUDING THOSE CONTAINING RAISIN, GRAPE, OR PRUNE JUICE) (U.S. CLS. 45, 46 AND 48).
FIRST USE 3-14-2011; IN COMMERCE 3-14-2011.

4,016,694. WINDOW TO THE WORLD COMMUNICATIONS, INC., CHICAGO, IL. SN 77-982,179. PUB. 11-2-2010, FILED 1-4-2010.

MISSION TO PLANET 429

THE MARK CONSISTS OF STANDARD CHARACTERS WITHOUT CLAIM TO ANY PARTICULAR FONT, STYLE, SIZE, OR COLOR.

CLASS 9—ELECTRICAL AND SCIENTIFIC APPARATUS

FOR GAME CONTROLLERS FOR COMPUTER GAMES; COMPUTER HARDWARE; DOWNLOADABLE COMPUTER SOFTWARE APPLICATIONS FOR PLAYING COMPUTER GAMES (U.S. CLS. 21, 23, 26, 36 AND 38).
FIRST USE 2-0-2011; IN COMMERCE 2-0-2011.

CLASS 41—EDUCATION AND ENTERTAINMENT

FOR ENTERTAINMENT SERVICES IN THE NATURE OF ON-GOING TELEVISION PROGRAMS IN THE FIELD OF CHILDREN'S ENTERTAINMENT; ENTERTAINMENT SERVICES, NAMELY, PROVIDING AN ONLINE COMPUTER GAME; PROVIDING AN INTERACTIVE ENTERTAINMENT WEBSITE FEATURING A FICTIONAL ADVENTURE WORLD FOR CHILDREN (U.S. CLS. 100, 101 AND 107).
FIRST USE 2-0-2011; IN COMMERCE 2-0-2011.

4,016,700. DISCERN GROUP, INC., MOUNTAIN VIEW, CA. SN 77-982,203. PUB. 6-8-2010, FILED 12-1-2009.

DISCERN

THE MARK CONSISTS OF STANDARD CHARACTERS WITHOUT CLAIM TO ANY PARTICULAR FONT, STYLE, SIZE, OR COLOR.

CLASS 35—ADVERTISING AND BUSINESS

FOR BUSINESS DATA ANALYSIS; PROVIDING INFORMATION IN THE FIELD OF ECONOMICS (U.S. CLS. 100, 101 AND 102).
FIRST USE 8-27-2010; IN COMMERCE 8-27-2010.

CLASS 36—INSURANCE AND FINANCIAL

FOR PROVIDING INFORMATION IN THE FIELDS OF FINANCE AND INVESTMENTS; FINANCIAL ANALYSIS AND RESEARCH SERVICES; FUND INVESTMENT CONSULTATION SERVICES (U.S. CLS. 100, 101 AND 102).
FIRST USE 5-6-2010; IN COMMERCE 5-6-2010.

CLASS 42—SCIENTIFIC AND COMPUTER SERVICES

FOR SOFTWARE AS A SERVICE (SAAS) SERVICES, NAMELY, HOSTING SOFTWARE FOR USE BY OTHERS IN CONNECTION WITH ANALYSIS OF INVESTMENT, BUSINESS, ECONOMIC AND SCIENTIFIC DATA; SCIENTIFIC ANALYSIS OF BIOLOGICAL, CHEMICAL, STATISTICAL, MATHEMATICS, PHYSICS OR ENGINEERING DATA (U.S. CLS. 100 AND 101).
FIRST USE 5-6-2010; IN COMMERCE 5-6-2010.

4,016,701. AMPAC ENTERPRISES, INC., SHIRLEY, MA. SN 77-982,207. PUB. 3-2-2010, FILED 10-5-2009.



THE MARK CONSISTS OF TWO CHEVRONS CONTAINING THE OUTLINE OF A FIVE-POINTED STAR.

CLASS 9—ELECTRICAL AND SCIENTIFIC APPARATUS

FOR BASEBALL BATTING HELMETS; CATCHERS' HELMETS; SPORTS HELMETS; CHIN STRAPS FOR FOOTBALL HELMETS (U.S. CLS. 21, 23, 26, 36 AND 38).
FIRST USE 1-1-2008; IN COMMERCE 5-1-2008.

CLASS 25—CLOTHING

FOR SWEAT BANDS; WRISTBANDS (U.S. CLS. 22 AND 39).
FIRST USE 1-1-2008; IN COMMERCE 5-1-2008.

CLASS 28—TOYS AND SPORTING GOODS

FOR BASEBALL AND SOFTBALL BAT RACKS; BASEBALL BASES; BASEBALL BAT BAGS, BASEBALL BAT CASES, BASEBALL BAT RACKS, BASEBALL BATS, BASEBALL BATTING GLOVES, BASEBALL BATTING TEES, BASEBALL GLOVES, BASEBALL MITTS, BASEBALLS, CATCHERS' MASKS, CATCHERS' MITTS, CHEST PROTECTORS, CHEST PROTECTORS FOR SPORTS, FOOTBALL GLOVES, FOOTBALL KNEE PADS, FOOTBALL LEG PADS, FOOTBALL SHOULDER PADS, FOOTBALL CHEST PADS (U.S. CLS. 22, 23, 38 AND 50).
FIRST USE 1-1-2008; IN COMMERCE 5-1-2008.

4,016,702. ZEERAY LLC, EATONTOWN, NJ. SN 77-982,222.
PUB. 12-16-2008, FILED 8-6-2007.

Enjoy Your Environment

THE MARK CONSISTS OF STANDARD CHARACTERS WITHOUT CLAIM TO ANY PARTICULAR FONT, STYLE, SIZE, OR COLOR.

CLASS 5—PHARMACEUTICALS

FOR AIR FRESHENERS (U.S. CLS. 6, 18, 44, 46, 51 AND 52).
FIRST USE 3-18-2008; IN COMMERCE 3-18-2008.

CLASS 11—ENVIRONMENTAL CONTROL APPARATUS

FOR DIFFUSERS FOR EMITTING SCENT; NON-ELECTRIC AIR DIFFUSERS COMPRISED OF A WICK AND OIL IN A CONTAINER USED TO EMIT SCENT WHEN LIT (U.S. CLS. 13, 21, 23, 31 AND 34).
FIRST USE 4-13-2009; IN COMMERCE 4-13-2009.

4,016,704. DES-SYN, INC., ATLANTA, GA. SN 77-982,229.
PUB. 4-27-2010, FILED 8-29-2008.

WELLNESS WITHIN YOUR WALLS

THE MARK CONSISTS OF STANDARD CHARACTERS WITHOUT CLAIM TO ANY PARTICULAR FONT, STYLE, SIZE, OR COLOR.

CLASS 16—PAPER GOODS AND PRINTED MATTER

FOR NEWSLETTERS IN THE FIELD OF ENVIRONMENTALLY FRIENDLY REAL ESTATE DEVELOPMENT AND CONSTRUCTION, LOW ENVIRONMENTAL IMPACT AND LOW OR NON-TOXIC INTERIOR DESIGN AND DECORATION, AND LOW-IMPACT ENVIRONMENTALLY FRIENDLY LANDSCAPING (U.S. CLS. 2, 5, 22, 23, 29, 37, 38 AND 50).
FIRST USE 6-22-2011; IN COMMERCE 6-22-2011.

CLASS 42—SCIENTIFIC AND COMPUTER SERVICES

FOR CONSULTING SERVICES IN THE FIELD OF ARCHITECTURAL DESIGN; RESIDENTIAL BUILDING DESIGN, COMMERCIAL BUILDING DESIGN, OFFICE BUILDING DESIGN, AND FACTORY BUILDING DESIGN, FEATURING ENVIRONMENTALLY FRIENDLY AND ENERGY EFFICIENT MATERIALS, NAMELY, DRYWALL, WOOD FLOORING, PAINT, SOLID SURFACE COUNTERS, CABINETS, LIGHTING, PLUMBING HARDWARE AND FIXTURES, APPLIANCES, INSULATION, PLYWOOD, INTERIOR PLASTER, WINDOWS, DOORS, ROOFING, TILE BACKSPASHES, TILE FLOORING, MATTRESSES, FABRICS, WALL COVERINGS, CARPETS, NAMELY, WALL-TO-WALL AND AREA RUGS, SOLAR TUBES, CEILING FANS, LIGHT BULBS, LINENS, EXTERIOR SIDING, RAIN CHAINS, HARDWARE FOR DOORS, WINDOWS, CABINETS AND FURNITURE, ENERGY EFFICIENT FOUNDATIONS, GRAY WATER TANKS, WIND POWER, GEO-THERMAL HVAC, ENVIRONMENTALLY FRIENDLY INTERIOR DESIGN SERVICES; ENVIRONMENTALLY FRIENDLY INTERIOR DECORATION CONSULTATION; LANDSCAPE ARCHITECTURAL DESIGN; LANDSCAPE LIGHTING DESIGN; COMPUTER SERVICES, NAMELY, PROVIDING DATABASES FEATURING INFORMATION IN THE FIELD OF ENVIRONMENTALLY FRIENDLY INTERIOR DESIGN (U.S. CLS. 100 AND 101).
FIRST USE 6-22-2011; IN COMMERCE 6-22-2011.

4,016,705. BROWN, SAMANTHA, NEW YORK, NY. SN 77-982,243. PUB. 12-9-2008, FILED 7-15-2008.



THE NAME(S), PORTRAIT(S), AND/OR SIGNATURE(S) SHOWN IN THE MARK IDENTIFIES "SAMANTHA BROWN", WHOSE CONSENT(S) TO REGISTER IS MADE OF RECORD.

THE MARK CONSISTS OF THE WORDING "SAMANTHA BROWN" IN STYLIZED FONT.

CLASS 18—LEATHER GOODS

FOR CARRY-ON BAGS; COSMETIC BAGS SOLD EMPTY; DUFFEL BAGS FOR TRAVEL; GARMENT BAGS FOR TRAVEL; MAKE-UP BAGS SOLD EMPTY; OVERNIGHT BAGS; SUIT BAGS; TOILETRY BAGS SOLD EMPTY; TOTE BAGS; TRAVEL BAGS; TRAVELING CASES OF LEATHER; WHEELED DUFFLE BAGS (U.S. CLS. 1, 2, 3, 22 AND 41).
FIRST USE 2-1-2010; IN COMMERCE 2-1-2010.

CLASS 39—TRANSPORTATION AND STORAGE

FOR ARRANGING FOR TRAVEL VISAS, PASSPORTS AND TRAVEL DOCUMENTS FOR PERSONS TRAVELING ABROAD; ARRANGING TRAVEL TOURS; COORDINATING TRAVEL ARRANGEMENTS FOR INDIVIDUALS AND FOR GROUPS; ORGANISATION OF TRAVEL; ORGANIZATION OF EXCURSIONS, SIGHTSEEING TOURS, HOLIDAYS, TOURS AND TRAVEL; PROVIDING INFORMATION, NEWS AND COMMENTARY IN THE FIELD OF TRAVEL; PROVIDING REVIEWS OF TRAVEL SERVICE PROVIDERS; TRAVEL AGENCY SERVICES, NAMELY, MAKING RESERVATIONS AND BOOKINGS FOR TRANSPORTATION; TRAVEL AND TOUR INFORMATION SERVICE (U.S. CLS. 100 AND 105).
FIRST USE 2-1-2010; IN COMMERCE 2-1-2010.

4,016,706. BRUNI, SIMONE, NEW ORLEANS, LA. SN 77-982,249. PUB. 6-29-2010, FILED 5-27-2008.

The Demo Diva

THE MARK CONSISTS OF STANDARD CHARACTERS WITHOUT CLAIM TO ANY PARTICULAR FONT, STYLE, SIZE, OR COLOR.

NO CLAIM IS MADE TO THE EXCLUSIVE RIGHT TO USE "DEMO", APART FROM THE MARK AS SHOWN.

CLASS 25—CLOTHING

FOR CLOTHING, NAMELY, T-SHIRTS, BOXER SHORTS, TANK TOPS (U.S. CLS. 22 AND 39).
FIRST USE 10-31-2006; IN COMMERCE 3-31-2010.

CLASS 37—CONSTRUCTION AND REPAIR

FOR HOUSE AND BUILDING DEMOLITION (U.S. CLS. 100, 103 AND 106).
FIRST USE 8-31-2006; IN COMMERCE 3-31-2010.

4,016,710. WESTFIELD, LLC, LOS ANGELES, CA. SN 77-982,330. PUB. 7-13-2010, FILED 5-6-2009.

W KIDS

THE MARK CONSISTS OF STANDARD CHARACTERS WITHOUT CLAIM TO ANY PARTICULAR FONT, STYLE, SIZE, OR COLOR.

NO CLAIM IS MADE TO THE EXCLUSIVE RIGHT TO USE "KIDS", APART FROM THE MARK AS SHOWN.

CLASS 41—EDUCATION AND ENTERTAINMENT

FOR PROVIDING CHILDREN'S PLAY AREAS; PROVIDING CHILDREN'S ACTIVITY AREAS AT SHOPPING CENTERS; PROVIDING SHOPPING MALL FAMILY LOUNGE FACILITIES FOR SHOPPER RELAXATION (U.S. CLS. 100, 101 AND 107).

FIRST USE 6-0-2008; IN COMMERCE 6-0-2008.

CLASS 43—HOTEL AND RESTAURANT SERVICES

FOR PROVIDING FAMILY DINING AREAS IN SHOPPING MALLS (U.S. CLS. 100 AND 101).
FIRST USE 6-0-2008; IN COMMERCE 6-0-2008.

4,016,712. KEYFRAME DIGITAL PRODUCTIONS INC., NIAGARA-ON-THE-LAKE, ONTARIO, CANADA. SN 78-187,670. PUB. 7-31-2007, FILED 11-21-2002.

HUGGLERS

PRIORITY CLAIMED UNDER SEC. 44(D) ON CANADA APPLICATION NO. 1,141,017, FILED 5-22-2002.

CLASS 9—ELECTRICAL AND SCIENTIFIC APPARATUS

FOR MUSICAL VIDEO RECORDINGS; PRERECORDED VIDEO DISCS FEATURING CHILDREN'S PROGRAMS (U.S. CLS. 21, 23, 26, 36 AND 38).
FIRST USE 4-0-2006; IN COMMERCE 12-0-2010.

CLASS 38—COMMUNICATION

FOR CABLE TELEVISION BROADCASTING; CABLE TELEVISION PROGRAMMING; CABLE TELEVISION TRANSMISSION; DISTRIBUTION OF TELEVISION PROGRAMMING TO CABLE TELEVISION SYSTEMS; DISTRIBUTION OF TELEVISION PROGRAMS; PAY-PER-VIEW TELEVISION TRANSMISSION SERVICES; SUBSCRIPTION TELEVISION BROADCASTING; TELEVISION BROADCASTING; VIDEO BROADCASTING; VIDEO-ON-DEMAND TRANSMISSION SERVICES (U.S. CLS. 100, 101 AND 104).
FIRST USE 12-0-2010; IN COMMERCE 12-0-2010.

CLASS 41—EDUCATION AND ENTERTAINMENT

FOR ENTERTAINMENT IN THE NATURE OF A TELEVISION SERIES FOR CHILDREN; ENTERTAINMENT, NAMELY, A CONTINUING CHILDREN'S LIVE ACTION AND ANIMATED SHOW DISTRIBUTED OVER TELEVISION, SATELLITE, AUDIO, AND VIDEO MEDIA; PRODUCTION OF CABLE TELEVISION PROGRAMS; PRODUCTION OF CLOSED CAPTION TELEVISION PROGRAMS; TELEVISION SHOW PRODUCTION (U.S. CLS. 100, 101 AND 107).
FIRST USE 12-0-2010; IN COMMERCE 12-0-2010.

4,016,715. KINETIX LIVING CORP., SEATTLE, WA. SN 78-665,023. PUB. 11-11-2008, FILED 7-6-2005.

KINETIX

THE MARK CONSISTS OF STANDARD CHARACTERS WITHOUT CLAIM TO ANY PARTICULAR FONT, STYLE, SIZE, OR COLOR.

CLASS 5—PHARMACEUTICALS

FOR DIETARY SUPPLEMENTS; NUTRITIONAL SUPPLEMENTS; DIETARY DRINK MIXES FOR USE AS A MEAL REPLACEMENT; MEAL REPLACEMENT AND DIETARY SUPPLEMENT DRINKS; NUTRITIONAL SUPPLEMENTS IN LIQUID, POWDER, AND BAR FORM, DESIGNED TO HELP FULFILL DIETARY REQUIREMENTS; NUTRITIONAL SUPPLEMENT BARS; NUTRITIONAL SHAKES FOR USE AS A MEAL SUBSTITUTE; NUTRITIONAL MEAL REPLACEMENT PRODUCTS, NAMELY, MEAL REPLACEMENT BARS, MEAL REPLACEMENT POWDERS, AND MEAL REPLACEMENT DRINKS (U.S. CLS. 6, 18, 44, 46, 51 AND 52).
FIRST USE 1-15-2005; IN COMMERCE 1-15-2005.

CLASS 16—PAPER GOODS AND PRINTED MATTER

FOR STATIONERY, WRITING PAPER, ENVELOPES, CALENDARS, BINDERS; STATIONERY-TYPE PORTFOLIOS; JOURNALS FOR RECORDING PERSONAL INFORMATION RELATING TO HEALTHCARE, NUTRITION, WEIGHT LOSS AND WEIGHT CONTROL; PERIODICAL PUBLICATIONS AND BROCHURES, NAMELY, MAGAZINES AND NEWSLETTERS THAT PERTAIN TO HEALTHCARE, NUTRITION, WEIGHT LOSS AND WEIGHT CONTROL; PRINTED TRAINING MANUALS, INSTRUCTIONAL TEACHING MATERIALS AND COOKBOOKS ALL FEATURING RECIPES, INFORMATION AND ADVICE ON HEALTHCARE, NUTRITION, WEIGHT LOSS AND WEIGHT CONTROL (U.S. CLS. 2, 5, 22, 23, 29, 37, 38 AND 50).

FIRST USE 1-15-2005; IN COMMERCE 1-15-2005.

CLASS 29—MEATS AND PROCESSED FOODS

FOR PACKAGED MEALS CONSISTING PRIMARILY OF MEAT, POULTRY, FISH, OR VEGETABLES; DAIRY BASED BEVERAGES; DAIRY BASED FOOD BEVERAGES; SOUPS, SOUP MIXES; SOY BASED SNACK FOODS; PROTEIN BASED SNACK BARS (U.S. CL. 46).

FIRST USE 1-15-2005; IN COMMERCE 1-15-2005.

CLASS 30—STAPLE FOODS

FOR READY-TO-EAT CEREAL DERIVED FOOD BARS; GRANOLA SNACK BARS; CEREAL-BASED SNACK FOODS; PACKAGED MEALS CONSISTING PRIMARILY OF PASTA OR RICE (U.S. CL. 46).

FIRST USE 1-15-2008; IN COMMERCE 1-15-2008.

CLASS 32—LIGHT BEVERAGES

FOR ENERGY DRINKS; SPORTS DRINKS (U.S. CLS. 45, 46 AND 48).

FIRST USE 1-15-2008; IN COMMERCE 1-15-2008.

CLASS 44—MEDICAL, BEAUTY AND AGRICULTURAL SERVICES

FOR WEIGHT REDUCTION DIET PLANNING AND SUPERVISION THROUGH THE USE OF COUNSELING AND CREATING DIET REGIMES; PROVIDING CONSULTATION SERVICES IN THE FIELDS OF HEALTHCARE, WEIGHT REDUCTION AND NUTRITION (U.S. CLS. 100 AND 101).

FIRST USE 1-15-2005; IN COMMERCE 1-15-2005.

4,016,717. FLOWERS, INC., BOGART, GA. SN 78-763,915.
PUB. 3-3-2009, FILED 11-30-2005.

B + B

THE MARK CONSISTS OF STANDARD CHARACTERS WITHOUT CLAIM TO ANY PARTICULAR FONT, STYLE, SIZE, OR COLOR.

CLASS 16—PAPER GOODS AND PRINTED MATTER

FOR PAPER BAGS FOR PACKAGING GIFTS, GIFT WRAPPING PAPER AND TISSUE; PRINTED CARDBOARD YARD SIGNS; SHREDDED PLASTIC AND PAPER STRIPS USED AS MATERIAL FOR PACKAGING GIFTS; CATALOGS AND NEWSLETTERS IN THE FIELD OF BALLOONS AND BALLOON ACCESSORIES, GIFTS AND GIFT ACCESSORIES, AND FLORAL AND CRAFT SUPPLIES; FLORAL AND CRAFT SUPPLIES, SPECIFICALLY, PAPER RIBBONS AND PAPER GIFT WRAPPING RIBBONS, CARDBOARD AND PAPER BOXES; PAPER, PLASTIC AND METALLIC GIFT WRAP; SHREDDED PAPER FOR PACKAGING, TISSUE PAPER FOR PACKAGING AND GIFT WRAPPING PURPOSES IN THE FORM OF SHEETS; PAPER, PLASTIC AND POLYETHELENE BAGS FOR PACKAGING, PLASTIC SHRINK WRAP FOR PACKAGING, PLASTIC ROLLS FOR GIFT WRAPPING AND PACKAGING; AND PAPER LINERS FOR BASKETS (U.S. CLS. 2, 5, 22, 23, 29, 37, 38 AND 50).

FIRST USE 6-5-2006; IN COMMERCE 6-19-2006.

CLASS 20—FURNITURE AND ARTICLES NOT OTHERWISE CLASSIFIED

FOR HOME ACCENT ITEMS, SPECIFICALLY, WINE RACKS, STOOLS, CHAIRS, TABLES AND MIRRORS; FURNITURE AND PICTURE FRAMES; DECORATIVE TABLE TOP ITEMS, SPECIFICALLY, SCULPTURES IN THE FORM OF CHERUBS AND FIGURINES ALL MADE OF IVORY, WOOD, POLYSTONE AND POLYRESIN; PLANT STANDS AND PLANT RACKS; AND PLASTIC INSERTS FOR USE AS CONTAINER LINERS (U.S. CLS. 2, 13, 22, 25, 32 AND 50).

FIRST USE 6-5-2006; IN COMMERCE 6-19-2006.

CLASS 21—HOUSEWARES AND GLASS

FOR MUGS AND GIFT PAILS; CERAMIC, CHINA AND PORCELAIN PRODUCTS, NAMELY, CUPS, MUGS, PLATES, PITCHERS, TEA POTS, BOWLS, PLATTERS, ORNAMENTS, FIGURES, SCULPTURES IN THE FORM OF CHERUBS, STATUES AND SCULPTURES; BASKETS FOR FLOWERS AND PLANTS, DECORATIVE BASKETS, AND BASKETS FOR USE AS HOME DECOR ITEMS, HOME ACCENT ITEMS, AND HOME FURNITURE ITEMS; PLANTERS, VASES, AND CANDLEHOLDERS; NON-METAL PIGGY BANKS; AND TRAYS (U.S. CLS. 2, 13, 23, 29, 30, 33, 40 AND 50).

FIRST USE 6-5-2006; IN COMMERCE 6-19-2006.

CLASS 28—TOYS AND SPORTING GOODS

FOR FOIL AND LATEX BALLOONS; PLUSH STUFFED TOY ANIMALS AND DOLLS AND OTHER PLUSH TOYS (U.S. CLS. 22, 23, 38 AND 50).

FIRST USE 6-5-2006; IN COMMERCE 6-19-2006.

CLASS 35—ADVERTISING AND BUSINESS

FOR DISTRIBUTORSHIP SERVICES IN THE FIELD OF BALLOONS AND BALLOON ACCESSORIES, GIFTS AND GIFT ACCESSORIES, FLORAL SUPPLIES, HOME ACCENT ITEMS, HOME DECOR ITEMS, CERAMIC ITEMS, TABLE SETTING ITEMS, DECORATIVE TABLETOP ITEMS, PLUSH TOY ANIMALS AND OTHER PLUSH ITEMS, MUGS, GIFTS, GIFT PACKAGING, ORNAMENTS, FIGURES, STATUES AND SCULPTURES, BASKETS, PLANTERS, VASES, CANDLEHOLDERS, AND SPECIALTY FOOD AND BEVERAGE ITEMS (U.S. CLS. 100, 101 AND 102).

FIRST USE 1-9-2006; IN COMMERCE 1-9-2006.

4,016,720. ENODIS CORPORATION, NEW PORT RICHEY, FL. SN 78-870,729. PUB. 5-18-2010, FILED 4-27-2006.

WELBILT

THE MARK CONSISTS OF STANDARD CHARACTERS WITHOUT CLAIM TO ANY PARTICULAR FONT, STYLE, SIZE, OR COLOR.

OWNER OF U.S. REG. NO. 2,578,170.
SEC. 2(F).

THE 2(F) CLAIM IS RESTRICTED TO CLASS(ES) 7, 8, 9, 11, 20, AND 21

CLASS 11—ENVIRONMENTAL CONTROL APPARATUS

FOR COMMERCIAL FOOD PREPARATION, DELIVERY AND STORAGE EQUIPMENT, NAMELY, GAS AND ELECTRIC GRILLS; GAS AND ELECTRIC GRIDDLES; GAS AND ELECTRIC FRYERS, FRYING FILTRATION SYSTEMS COMPRISED OF VENTS AND FILTERS, ELECTRIC FOOD STEAMERS, ELECTRIC KETTLES, ELECTRIC COOKERS, ELECTRIC HOTPLATES, ELECTRIC SKILLETS, OVENS, GAS AND ELECTRIC RANGES, COMBI-OVENS, MICROWAVE OVENS, CONVEYOR OVENS, COOK-CHILL SYSTEMS, COMPRISED OF RAPID REFRIGERATION COMPRESSORS, REFRIGERATION UNITS, REFRIGERATED MERCHANDISE DISPLAY CASES, NAMELY, SELF-SERVICE CASES AND SERVICE DELI CASES, CUSTOM FABRICATED REFRIGERATION SYSTEMS, COMPRISED OF MODULAR REFRIGERATION UNITS USED BY SUPERMARKETS AND CONVENIENCE STORES TO STORE AND DISPLAY FOOD AND BEVERAGE PRODUCTS, ICE MAKING AND DISPENSING EQUIPMENT, NAMELY, ICE MAKING MACHINES, COMMERCIAL REFRIGERATORS AND FREEZERS, BLAST CHILLERS, AIR PURIFICATION AND VENTILATION SYSTEMS, COMPRISED OF SEPARATORS AND OVEN VENTILATION HOODS; ELECTRIC BROILERS, ROTISSERIES PARTS AND FITTINGS FOR ALL THE AFORESAID GOODS (U.S. CLS. 13, 21, 23, 31 AND 34).

FIRST USE 1-0-2010; IN COMMERCE 1-0-2010.

CLASS 20—FURNITURE AND ARTICLES NOT OTHERWISE CLASSIFIED

FOR FOOD PREPARATION TABLES AND INTEGRATED FOOD PREPARATION WORKSTATIONS; SERVING TROLLEYS; AND PARTS FOR ALL THE AFORESAID GOODS (U.S. CLS. 2, 13, 22, 25, 32 AND 50).

FIRST USE 1-0-2010; IN COMMERCE 1-0-2010.

4,016,723. SOHO HOUSE LIMITED, LONDON, UNITED KINGDOM. SN 78-944,768. PUB. 4-15-2008, FILED 8-4-2006.

SOHO BEACH HOUSE

THE MARK CONSISTS OF STANDARD CHARACTERS WITHOUT CLAIM TO ANY PARTICULAR FONT, STYLE, SIZE, OR COLOR.

NO CLAIM IS MADE TO THE EXCLUSIVE RIGHT TO USE "BEACH HOUSE", APART FROM THE MARK AS SHOWN.

CLASS 41—EDUCATION AND ENTERTAINMENT

FOR COUNTRY CLUBS; ARRANGING FOR TICKET RESERVATIONS FOR SHOWS AND OTHER ENTERTAINMENT EVENTS; ARRANGING OF EXHIBITIONS, SEMINARS AND CONFERENCES; CINEMA THEATERS; GYMNASIUMS HEALTH CLUB SERVICES, NAMELY, PROVIDING INSTRUCTION AND EQUIPMENT IN THE FIELD OF PHYSICAL EXERCISE; ORGANIZING EXHIBITIONS FOR ENTERTAINMENT PURPOSE; PHYSICAL FITNESS CONSULTATION; PHYSICAL FITNESS INSTRUCTION (U.S. CLS. 100, 101 AND 107).

FIRST USE 10-5-2010; IN COMMERCE 10-5-2010.

CLASS 43—HOTEL AND RESTAURANT SERVICES

FOR BAR SERVICES; CAFES; CAFE-RESTAURANTS; CATERING; COCKTAIL LOUNGE BUFFETS; COCKTAIL LOUNGES; COFFEE SHOPS; HEALTH RESORT SERVICES, NAMELY, PROVIDING FOOD AND LODGING THAT SPECIALIZE IN PROMOTING PATRONS' GENERAL HEALTH AND WELL-BEING; HOTEL SERVICES FOR PREFERRED CUSTOMERS; HOTEL, BAR AND RESTAURANT SERVICES; CONDO HOTELS; PROVIDING CONFERENCE ROOMS; PROVIDING FACILITIES FOR EXHIBITIONS; PROVISION OF CONFERENCE, EXHIBITION AND MEETING FACILITIES; RESERVATION OF HOTEL ROOMS FOR TRAVELERS; RESORT HOTELS; SERVING FOOD AND DRINKS; SPA SERVICES, NAMELY, PROVIDING TEMPORARY ACCOMMODATIONS AND MEALS TO CLIENTS OF A HEALTH OR BEAUTY SPA (U.S. CLS. 100 AND 101).

FIRST USE 10-5-2010; IN COMMERCE 10-5-2010.

4,016,725. MONEY MISSION, LLC, MILWAUKEE, WI. SN 85-001,582. PUB. 10-19-2010, FILED 3-30-2010.

MONEY MISSION

THE MARK CONSISTS OF STANDARD CHARACTERS WITHOUT CLAIM TO ANY PARTICULAR FONT, STYLE, SIZE, OR COLOR.

NO CLAIM IS MADE TO THE EXCLUSIVE RIGHT TO USE "MONEY" FOR INTERNATIONAL CLASSES 9, 16 AND 41, APART FROM THE MARK AS SHOWN.

CLASS 9—ELECTRICAL AND SCIENTIFIC APPARATUS

FOR COMPUTER PROGRAMS FOR EDUCATIONAL SIMULATIONS IN THE FIELD OF FINANCIAL LITERACY; DVDS FEATURING FINANCIAL LITERACY MATERIALS; MOUSE PADS (U.S. CLS. 21, 23, 26, 36 AND 38).

FIRST USE 5-12-2010; IN COMMERCE 6-12-2010.

CLASS 16—PAPER GOODS AND PRINTED MATTER

FOR PUBLICATIONS, NAMELY, HAND-OUTS, WORKBOOKS, AND STUDY GUIDES IN THE FIELDS OF FINANCIAL LITERACY (U.S. CLS. 2, 5, 22, 23, 29, 37, 38 AND 50).

FIRST USE 4-14-2011; IN COMMERCE 4-14-2011.

CLASS 18—LEATHER GOODS

FOR BACKPACKS (U.S. CLS. 1, 2, 3, 22 AND 41).

FIRST USE 5-12-2010; IN COMMERCE 5-12-2010.

CLASS 21—HOUSEWARES AND GLASS

FOR DRINKING VESSELS; THERMAL INSULATED CONTAINERS FOR FOOD OR BEVERAGES (U.S. CLS. 2, 13, 23, 29, 30, 33, 40 AND 50).

FIRST USE 4-9-2011; IN COMMERCE 4-9-2011.

CLASS 25—CLOTHING

FOR HATS; SHIRTS (U.S. CLS. 22 AND 39).

FIRST USE 5-12-2010; IN COMMERCE 5-12-2010.

CLASS 41—EDUCATION AND ENTERTAINMENT

FOR EDUCATIONAL SERVICES, NAMELY, DEVELOPING AND CONDUCTING TRAINING COURSES AND DISTRIBUTION OF TRAINING MATERIALS IN CONNECTION THEREWITH FOR SUBJECT MATTERS AS REQUESTED BY CUSTOMERS; EDUCATIONAL SERVICES, NAMELY, PROVIDING ON-LINE TRAINING MODULES IN THE FIELD OF FINANCIAL LITERACY (U.S. CLS. 100, 101 AND 107).

FIRST USE 5-12-2010; IN COMMERCE 7-15-2010.

4,016,737. HAYWARD INDUSTRIES, INC., ELIZABETH, NJ. SN 85-007,530. PUB. 10-26-2010, FILED 4-6-2010.



OWNER OF U.S. REG. NOS. 1,132,980 AND 1,207,109.

THE MARK CONSISTS OF THE CAPITAL LETTER "H", BISECTED HORIZONTALLY BY A LINE WITH PEAKS AND VALLEYS REMINISCENT OF WAVES ON WATER, ENCLOSED WITHIN A CIRCLE WHICH IN TURN IS ENCLOSED WITHIN A LARGER SQUARE.

CLASS 7—MACHINERY

FOR PUMPS, PARTS AND FITTINGS THEREFOR FOR USE IN SWIMMING POOLS, SPAS, HOT TUBS, WHIRLPOOLS, AND OTHER RECREATIONAL BODIES OF WATER; AUTOMATIC SWIMMING POOL CLEANERS; UNDERWATER SWIMMING POOL CLEANING MACHINES FOR CLEANING THE SURFACE OF A SWIMMING POOL; SUCTION OUTLETS, NAMELY, PUMPS FOR REMOVING WATER FROM SWIMMING POOLS, SPAS, HOT TUBS, WHIRLPOOLS, AND OTHER RECREATIONAL BODIES OF WATER (U.S. CLS. 13, 19, 21, 23, 31, 34 AND 35).

FIRST USE 12-31-2009; IN COMMERCE 12-31-2009.

CLASS 9—ELECTRICAL AND SCIENTIFIC APPARATUS

FOR ELECTRONIC CONTROLS FOR USE IN SWIMMING POOLS, SPAS, HOT TUBS, WHIRLPOOLS, AND OTHER RECREATIONAL BODIES OF WATER; AUTOMATED WATER CHEMISTRY CONTROLLERS, NAMELY, ELECTRONIC CONTROLLER APPARATUS FOR MONITORING WATER CHEMISTRY AND CONTROLLING ADDITION OF CHEMICALS TO WATER FOR SWIMMING POOLS, SPAS, HOT TUBS, AND WHIRLPOOLS; REMOTE CONTROL UNITS, NAMELY, WIRELESS CONTROLS ACCESSIBLE VIA GLOBAL AND LOCAL COMPUTER NETWORKS, FOR CONTROLLING WATER MANAGEMENT AND TREATMENT SYSTEMS CONSISTING OF TIMERS, CHLORINATORS, HEATERS, PUMPS, AND ACTUATORS OF SWIMMING POOLS, SPAS, HOT TUBS, WHIRLPOOLS, WATER FEATURES AND OTHER RECREATIONAL BODIES OF WATER; MULTI-PURPOSE CONTROLLERS FOR SWIMMING POOLS, SPAS, HOT TUBS, WHIRLPOOLS, WATER FEATURES, AND OTHER RECREATIONAL BODIES OF WATER FOR AUTOMATICALLY CONTROLLING WATER CHLORINATION, FILTER PUMP TIMING, TEMPERATURES, ACTUATORS, AND WATER MANAGEMENT AND TREATMENT SYSTEMS; ELECTRONIC CONTROL PANEL WITH DIGITAL DISPLAYS FOR THE COMPLETE MONITORING AND AUTOMATION OF FILTRATION, PURIFICATION, AND SOLAR HEATING SYSTEMS OF SWIMMING POOLS, SPAS, HOT TUBS, WHIRLPOOLS, AND OTHER RECREATIONAL BODIES OF WATER; ELECTRONIC CONTROLLERS FOR SOLAR HEATING SYSTEM FOR SWIMMING POOLS AND SPAS, NAMELY, SOLAR POWERED ELECTRONIC CONTROLLERS FOR CONTROLLING THE TEMPERATURE OF SWIMMING POOLS AND SPAS; AUTOMATIC TIMERS FOR CONTROLLING OPERATION OF FILTERS FOR SWIMMING POOLS AND SPAS; REMOTE CONTROL UNITS, NAMELY, WIRELESS AND WIRED CONTROLS FOR CONTROLLING COMPONENTS OF SWIMMING POOLS, SPAS, HOT TUBS, WHIRLPOOLS, WATER FEATURES, AND OTHER RECREATIONAL BODIES OF WATER; ELECTRIC VALVE ACTUATORS; ELECTRONIC CONTROL SYSTEMS COMPRISED OF AN ELECTROLYTIC CHLORINE GENERATOR AND MULTI-PURPOSE CONTROLLER FOR CONTROLLING THE OPERATION, SANITIZATION AND MAINTENANCE OF SWIMMING POOLS, SPAS AND OTHER RECREATIONAL BODIES OF WATER (U.S. CLS. 21, 23, 26, 36 AND 38).

FIRST USE 12-31-2009; IN COMMERCE 12-31-2009.

CLASS 11—ENVIRONMENTAL CONTROL APPARATUS

FOR FILTERS AND PARTS AND FITTINGS THEREFOR, HEATERS AND PARTS AND FITTINGS THEREFOR, SALT AND CHLORINE GENERATORS AND PARTS AND FITTINGS THEREFOR, LIGHTS AND VALVES AND PARTS AND FITTINGS THEREFOR, ALL FOR USE IN SWIMMING POOLS, SPAS, HOT TUBS, WHIRLPOOLS, AND OTHER RECREATIONAL BODIES OF WATER (U.S. CLS. 13, 21, 23, 31 AND 34).

FIRST USE 12-31-2009; IN COMMERCE 12-31-2009.

4,016,746. CHEVAL CREATIVE, LLC, ASPEN, CO. SN 85-011,056. PUB. 10-26-2010, FILED 4-9-2010.

OPERA MICE

THE MARK CONSISTS OF STANDARD CHARACTERS WITHOUT CLAIM TO ANY PARTICULAR FONT, STYLE, SIZE, OR COLOR.

NO CLAIM IS MADE TO THE EXCLUSIVE RIGHT TO USE "OPERA" AS TO CLASS 41 OR "MICE" AS TO CLASS 28,

APART FROM THE MARK AS SHOWN.

4,016,753. FARMERS GROUP, INC., LOS ANGELES, CA. SN 85-013,484. PUB. 11-2-2010, FILED 4-14-2010.

CLASS 28—TOYS AND SPORTING GOODS

FOR PLUSH TOYS (U.S. CLS. 22, 23, 38 AND 50).
FIRST USE 7-8-2010; IN COMMERCE 7-8-2010.

CLASS 41—EDUCATION AND ENTERTAINMENT

FOR PROVIDING A WEBSITE FEATURING EDUCATION AND ENTERTAINMENT FOR CHILDREN (U.S. CLS. 100, 101 AND 107).
FIRST USE 5-5-2010; IN COMMERCE 5-5-2010.

IFARMERS

THE MARK CONSISTS OF STANDARD CHARACTERS WITHOUT CLAIM TO ANY PARTICULAR FONT, STYLE, SIZE, OR COLOR.

OWNER OF U.S. REG. NOS. 953,862, 3,499,990, AND OTHERS.

4,016,750. STARGREETZ, INC., LOS ANGELES, CA. SN 85-012,741. PUB. 9-14-2010, FILED 4-13-2010.

STARGREETZ

THE MARK CONSISTS OF STANDARD CHARACTERS WITHOUT CLAIM TO ANY PARTICULAR FONT, STYLE, SIZE, OR COLOR.

CLASS 9—ELECTRICAL AND SCIENTIFIC APPARATUS

FOR COMPUTER SOFTWARE FOR MANIPULATING DIGITAL AUDIO INFORMATION FOR USE IN AUDIO MEDIA APPLICATIONS; COMPUTER SOFTWARE PLATFORMS FOR CUSTOMIZING MULTIMEDIA ENTERTAINMENT CONTENT THAT WILL BE DISTRIBUTED VIA THE INTERNET AND WIRELESS DEVICES; DOWNLOADABLE RING TONES, RINGBACK TONES, ALERTS, VOICEMAIL, ELECTRONIC MESSAGES, AND MULTIMEDIA RECORDINGS VIA THE INTERNET AND WIRELESS DEVICES (U.S. CLS. 21, 23, 26, 36 AND 38).

FIRST USE 6-3-2010; IN COMMERCE 6-11-2010.

CLASS 35—ADVERTISING AND BUSINESS

FOR ON-LINE RETAIL STORE SERVICES FEATURING COMPUTER, ELECTRONIC AND ENTERTAINMENT PRODUCTS, DOWNLOADABLE RING TONES, RINGBACK TONES, ALERTS, VOICEMAIL, ELECTRONIC MESSAGES, AND MULTIMEDIA RECORDINGS, AND STREAMED DIGITAL ENTERTAINMENT MEDIA CONTENT (U.S. CLS. 100, 101 AND 102).

FIRST USE 6-3-2010; IN COMMERCE 6-11-2010.

CLASS 41—EDUCATION AND ENTERTAINMENT

FOR ENTERTAINMENT SERVICES IN THE NATURE OF DEVELOPMENT, CREATION, PRODUCTION AND POST-PRODUCTION SERVICES OF MULTIMEDIA ENTERTAINMENT CONTENT; ENTERTAINMENT SERVICES, NAMELY, MULTIMEDIA PRODUCTION SERVICES; PRODUCTION OF AUDIO RECORDING (U.S. CLS. 100, 101 AND 107).

FIRST USE 1-18-2010; IN COMMERCE 1-18-2010.

CLASS 9—ELECTRICAL AND SCIENTIFIC APPARATUS

FOR MOBILE PHONE APPLICATIONS, NAMELY, SOFTWARE DOWNLOADED TO MOBILE PHONE DEVICES USED FOR THE PURPOSE OF PROVIDING INFORMATION TO INSURANCE CUSTOMERS ABOUT THEIR POLICIES, MAKING INSURANCE PAYMENTS, MAKING, PROCESSING AND GETTING INFORMATION ABOUT INSURANCE CLAIMS, AND PROVIDING INFORMATION ABOUT ROADSIDE UTILITIES AND TRAVEL SERVICES (U.S. CLS. 21, 23, 26, 36 AND 38).

FIRST USE 11-4-2009; IN COMMERCE 6-4-2010.

CLASS 36—INSURANCE AND FINANCIAL

FOR INSURANCE UNDERWRITING SERVICES IN THE FIELD OF PROPERTY AND CASUALTY, AUTOMOBILE, HOMEOWNERS, AND LIFE INSURANCE; INSURANCE ADMINISTRATION; INSURANCE CLAIMS PROCESSING, INSURANCE CLAIMS ADMINISTRATION, AND INSURANCE AGENCY SERVICES; PROVIDING INFORMATION ABOUT INSURANCE AND UNDERWRITING VIA THE INTERNET (U.S. CLS. 100, 101 AND 102).

FIRST USE 11-4-2009; IN COMMERCE 6-4-2010.

4,016,755. RECKITT BENCKISER LLC, PARSIPPANY, NJ. SN 85-014,089. PUB. 10-26-2010, FILED 4-14-2010.

WINTER LUXURY

THE MARK CONSISTS OF STANDARD CHARACTERS WITHOUT CLAIM TO ANY PARTICULAR FONT, STYLE, SIZE, OR COLOR.

CLASS 3—COSMETICS AND CLEANING PREPARATIONS

FOR ESSENTIAL OILS, ROOM PERFUME SPRAYS; PREPARATIONS FOR PERFUMING OR FRAGRANCING THE AIR, NAMELY, ROOM FRAGRANCES (U.S. CLS. 1, 4, 6, 50, 51 AND 52).

FIRST USE 8-1-2010; IN COMMERCE 8-1-2010.

CLASS 4—LUBRICANTS AND FUELS

FOR CANDLES; FRAGRANCED OR SCENTED CANDLES (U.S. CLS. 1, 6 AND 15).

FIRST USE 8-1-2010; IN COMMERCE 8-1-2010.

CLASS 5—PHARMACEUTICALS

FOR AIR FRESHENING PREPARATIONS; AIR PURIFYING PREPARATIONS IN THE NATURE OF AIR DEODORIZERS; ROOM AIR FRESHENERS; ROOM DEODORANTS; PREPARATIONS FOR NEUTRALIZING ODORS ON CARPETS, TEXTILES AND IN THE AIR (U.S. CLS. 6, 18, 44, 46, 51 AND 52).

FIRST USE 8-1-2010; IN COMMERCE 8-1-2010.

CLASS 11—ENVIRONMENTAL CONTROL APPARATUS

FOR APPARATUS AND INSTRUMENTS, NAMELY, ELECTRIC AND BATTERY POWERED DISPENSING UNITS FOR SCENTING, PURIFYING OR FRESHENING THE ATMOSPHERE; PARTS AND FITTINGS FOR ALL THE AFORESAID GOODS; FLAMELESS CANDLES (U.S. CLS. 13, 21, 23, 31 AND 34).

FIRST USE 8-1-2010; IN COMMERCE 8-1-2010.

4,016,757. FARMERS GROUP, INC., LOS ANGELES, CA. SN 85-015,075. PUB. 12-14-2010, FILED 4-15-2010.

MYSAFETYPOINT

THE MARK CONSISTS OF STANDARD CHARACTERS WITHOUT CLAIM TO ANY PARTICULAR FONT, STYLE, SIZE, OR COLOR.

CLASS 35—ADVERTISING AND BUSINESS

FOR PROVIDING A WEBSITE FOR COMMERCIAL POLICYHOLDERS AND AGENTS THAT OFFERS BUSINESS RISK MANAGEMENT TOOLS TO HELP CONTROL EXPOSURES TO LOSS (U.S. CLS. 100, 101 AND 102).

FIRST USE 4-1-2011; IN COMMERCE 6-1-2011.

CLASS 36—INSURANCE AND FINANCIAL

FOR PROVIDING COMMERCIAL INSURANCE AND UNDERWRITING INFORMATION VIA THE INTERNET (U.S. CLS. 100, 101 AND 102).

FIRST USE 4-1-2011; IN COMMERCE 6-1-2011.

4,016,761. ULTRAMARINE, LLC, RIDGEFIELD, CT. SN 85-017,646. PUB. 9-21-2010, FILED 4-19-2010.

ULTRAMARINE

THE MARK CONSISTS OF STANDARD CHARACTERS WITHOUT CLAIM TO ANY PARTICULAR FONT, STYLE, SIZE, OR COLOR.

CLASS 29—MEATS AND PROCESSED FOODS

FOR CANNED FISH, CANNED VEGETABLES, PROCESSED OLIVES, OLIVE OIL (U.S. CL. 46).

FIRST USE 5-1-2011; IN COMMERCE 5-1-2011.

CLASS 33—WINES AND SPIRITS

FOR TABLE WINES, WINES (U.S. CLS. 47 AND 49). FIRST USE 5-1-2011; IN COMMERCE 5-1-2011.

4,016,766. FERNANDO MIGLIASSI, MIAMI, FL. SN 85-020,676. PUB. 1-25-2011, FILED 4-22-2010.

ICECYCLE

THE MARK CONSISTS OF STANDARD CHARACTERS WITHOUT CLAIM TO ANY PARTICULAR FONT, STYLE, SIZE, OR COLOR.

CLASS 11—ENVIRONMENTAL CONTROL APPARATUS

FOR A COOLING AND WARMING MECHANISM IN THE NATURE OF A PERSONAL WARMING AND COOLING SYSTEM COMPRISING CHEMICALLY-ACTIVATED GEL PACKS THAT ARE AFFIXED TO THE BACK VIA STRAPS OR CLIPS AND MAY BE WORN UNDER OR OVER CLOTHING, FOR THE PURPOSE OF MAINTAINING BODY TEMPERATURE, FOR USE WHILE BICYCLING, USING EXERCISE EQUIPMENT, PERFORMING ATHLETIC OR OUTDOOR ACTIVITIES, THE FOREGOING NOT FOR MEDICAL PURPOSES (U.S. CLS. 13, 21, 23, 31 AND 34).

FIRST USE 2-4-2011; IN COMMERCE 2-4-2011.

CLASS 25—CLOTHING

FOR ATHLETIC APPAREL, NAMELY, TOPS, BOTTOMS, SHORTS, SHIRTS, JACKETS, SOCKS, HATS AND CAPS, ATHLETIC UNIFORMS, JERSEYS, GLOVES (U.S. CLS. 22 AND 39).

FIRST USE 2-4-2011; IN COMMERCE 2-4-2011.

4,016,770. MASAFUMI WATANABE, TOKYO, JAPAN. SN 85-022,713. PUB. 12-21-2010, FILED 4-26-2010.

BEDWIN & THE HEARTBREAKERS

THE MARK CONSISTS OF THE WORD "BEDWIN" AND AN AMPERSAND TO THE RIGHT AND ABOVE THE WORDS "THE HEARTBREAKERS".

CLASS 14—JEWELRY

FOR KEY RINGS OF PRECIOUS METAL, TROPHIES OF PRECIOUS METAL, COMMEMORATIVE SHIELDS OF PRECIOUS METAL, PERSONAL ORNAMENTS OF PRECIOUS METAL (U.S. CLS. 2, 27, 28 AND 50).

FIRST USE 4-1-2010; IN COMMERCE 4-14-2011.

CLASS 18—LEATHER GOODS

FOR BAGS, NAMELY, SHOULDER BAGS, CARRY-ON BAGS, BACKPACKS; CREDIT CARD CASES, PURSES, WALLETS, BUSINESS CARD CASES; VANITY CASES SOLD EMPTY (U.S. CLS. 1, 2, 3, 22 AND 41).

FIRST USE 4-1-2010; IN COMMERCE 4-14-2011.

CLASS 25—CLOTHING

FOR CLOTHING, NAMELY, JACKETS, SWEAT PANTS, SUITS, TROUSERS, SMOCKS, OVERCOATS, TOPCOATS, CARDIGANS, SWEATERS, VESTS AND WAISTCOATS, SPORT SHIRTS, POLO SHIRTS, SHIRTS FOR SUITS, PANTIES, SHORTS AND BRIEFS, APRONS, SOCKS AND STOCKINGS, SHAWLS, SCARVES, GLOVES AND MITTENS, NECKTIES, NECKERCHIEFS, BANDANAS, MUFFLERS, GARTERS, SOCK SUSPENDERS, SUSPENDERS, BELTS FOR CLOTHING, FOOTWEAR (U.S. CLS. 22 AND 39).

FIRST USE 4-1-2010; IN COMMERCE 4-14-2011.

4,016,783. GRACE HAWTHORNE, MILL VALLEY, CA. SN 85-028,001. PUB. 4-19-2011, FILED 4-30-2010.

PAPER PUNK

THE MARK CONSISTS OF STANDARD CHARACTERS WITHOUT CLAIM TO ANY PARTICULAR FONT, STYLE, SIZE, OR COLOR.

NO CLAIM IS MADE TO THE EXCLUSIVE RIGHT TO USE "PAPER", APART FROM THE MARK AS SHOWN.

CLASS 16—PAPER GOODS AND PRINTED MATTER

FOR EDUCATIONAL CHILDREN'S ARTS AND CRAFTS PAPER KITS COMPRISING PRE-CUT, PRE-SCORED, FOLD-TO-BUILD 3D GEOMETRIC PAPER SHAPES INCLUDING DESIGN STICKERS FOR ATTACHMENT TO PAPER SHAPES (U.S. CLS. 2, 5, 22, 23, 29, 37, 38 AND 50).

FIRST USE 9-22-2009; IN COMMERCE 6-7-2011.

CLASS 28—TOYS AND SPORTING GOODS

FOR EDUCATIONAL PUZZLES COMPRISED OF PRE-CUT, PRE-SCORED, FOLD-TO-BUILD 3D GEOMETRIC PAPER BLOCKS (U.S. CLS. 22, 23, 38 AND 50).

FIRST USE 9-22-2009; IN COMMERCE 6-7-2011.

4,016,784. SUPERNOVA DIAGNOSTICS, INC., DAMMASCUS, MD. SN 85-028,327. PUB. 10-5-2010, FILED 5-3-2010.

PUTTING THE LABORATORY IN THE PALM OF YOUR HAND

THE MARK CONSISTS OF STANDARD CHARACTERS WITHOUT CLAIM TO ANY PARTICULAR FONT, STYLE, SIZE, OR COLOR.

CLASS 9—ELECTRICAL AND SCIENTIFIC APPARATUS

FOR DIAGNOSTIC APPARATUS FOR TESTING HUMAN AND NON-HUMAN PATHOGENS, PROTEINS AND NUCLEIC ACID, NAMELY, DNA FOR LABORATORY OR RESEARCH USE (U.S. CLS. 21, 23, 26, 36 AND 38).

FIRST USE 3-1-2011; IN COMMERCE 3-1-2011.

CLASS 10—MEDICAL APPARATUS

FOR MEDICAL DIAGNOSTIC APPARATUS FOR TESTING HUMAN AND NON-HUMAN PATHOGENS, PROTEINS AND NUCLEIC ACID, NAMELY, DNA (U.S. CLS. 26, 39 AND 44).

FIRST USE 3-1-2011; IN COMMERCE 3-1-2011.

4,016,799. CONSUMER CREDIT COUNSELING SERVICE OF GREATER ATLANTA, INC., ATLANTA, GA. SN 85-034,855. PUB. 10-5-2010, FILED 5-10-2010.

GIVE YOURSELF THE ABILITY

THE MARK CONSISTS OF STANDARD CHARACTERS WITHOUT CLAIM TO ANY PARTICULAR FONT, STYLE, SIZE, OR COLOR.

CLASS 36—INSURANCE AND FINANCIAL

FOR DEBT, CREDIT AND BUDGET COUNSELING SERVICES, NAMELY, PROVIDING GUIDANCE TO INDIVIDUALS IN THE AREAS OF FINANCIAL PLANNING, FINANCIAL BUDGETING, FINANCIAL RECOVERY, DEBT MANAGEMENT, BANKRUPTCY, HOME OWNERSHIP, AND HOME RETENTION; DEBT REPAYMENT PLANNING AND SCHEDULING; DEBT MANAGEMENT SERVICES (U.S. CLS. 100, 101 AND 102).

FIRST USE 6-14-2010; IN COMMERCE 6-14-2010.

CLASS 41—EDUCATION AND ENTERTAINMENT

FOR EDUCATIONAL SERVICES, NAMELY, CONDUCTING SEMINARS, WORKSHOPS, AND INDIVIDUAL INSTRUCTION IN THE FIELD OF CREDIT, DEBT AND MONEY MANAGEMENT, FINANCIAL LITERACY, BANKRUPTCY, HOME OWNERSHIP AND HOME RETENTION (U.S. CLS. 100, 101 AND 107).

FIRST USE 6-14-2010; IN COMMERCE 6-14-2010.

4,016,804. SCHOOL SPECIALTY, INC., APPLETON, WI. SN 85-036,884. PUB. 1-11-2011, FILED 5-12-2010.

PORTFOLIO

THE MARK CONSISTS OF STANDARD CHARACTERS WITHOUT CLAIM TO ANY PARTICULAR FONT, STYLE, SIZE, OR COLOR.

CLASS 9—ELECTRICAL AND SCIENTIFIC APPARATUS

FOR COMPUTER SOFTWARE AND DOWNLOADABLE COMPUTER SOFTWARE FOR USE BY ELEMENTARY AND SECONDARY SCHOOL STUDENTS AND TEACHERS IN THE FIELD OF ORAL READING FLUENCY AND COMPREHENSION CURRICULUM (U.S. CLS. 21, 23, 26, 36 AND 38).

FIRST USE 9-7-2010; IN COMMERCE 9-7-2010.

CLASS 39—TRANSPORTATION AND STORAGE

FOR ELECTRONIC STORAGE OF DATA (U.S. CLS. 100 AND 105).
FIRST USE 8-8-2010; IN COMMERCE 8-8-2010.

CLASS 42—SCIENTIFIC AND COMPUTER SERVICES

FOR PROVIDING ON-LINE NON-DOWNLOADABLE COMPUTER SOFTWARE FOR USE BY ELEMENTARY AND SECONDARY SCHOOL STUDENTS AND TEACHERS IN THE FIELD OF ORAL READING FLUENCY AND COMPREHENSION CURRICULUM (U.S. CLS. 100 AND 101).
FIRST USE 8-8-2010; IN COMMERCE 8-8-2010.

4,016,807. B-CYCLE LLC, WATERLOO, WI. SN 85-037,925.
PUB. 11-30-2010, FILED 5-13-2010.

BOULDER BCYCLE

THE MARK CONSISTS OF STANDARD CHARACTERS WITHOUT CLAIM TO ANY PARTICULAR FONT, STYLE, SIZE, OR COLOR.

OWNER OF U.S. REG. NOS. 3,700,047, 3,700,048, AND 3,790,814.

NO CLAIM IS MADE TO THE EXCLUSIVE RIGHT TO USE "BOULDER", APART FROM THE MARK AS SHOWN.

CLASS 35—ADVERTISING AND BUSINESS

FOR COMMERCIAL ADMINISTRATION OF THE LICENSING OF BICYCLE RENTAL, REPAIR AND MAINTENANCE SERVICES FOR OTHERS; TRACKING, LOCATING AND MONITORING OF BICYCLES FOR COMMERCIAL PURPOSES; BUSINESS MANAGEMENT SERVICES, NAMELY, MANAGEMENT OF BICYCLE RENTAL FLEETS FOR OTHERS (U.S. CLS. 100, 101 AND 102).

FIRST USE 5-20-2011; IN COMMERCE 5-20-2011.

CLASS 39—TRANSPORTATION AND STORAGE

FOR RENTAL OF BICYCLES AND BICYCLE ACCESSORIES, BICYCLE TRANSPORT, PROVIDING ONLINE INFORMATION PERTAINING TO THE RENTAL OF BICYCLES (U.S. CLS. 100 AND 105).

FIRST USE 5-20-2011; IN COMMERCE 5-20-2011.

WAYS GO

THE MARK CONSISTS OF STANDARD CHARACTERS WITHOUT CLAIM TO ANY PARTICULAR FONT, STYLE, SIZE, OR COLOR.

CLASS 35—ADVERTISING AND BUSINESS

FOR ADVERTISING, MARKETING AND PROMOTIONAL SERVICES RELATED TO ALL INDUSTRIES FOR THE PURPOSE OF FACILITATING NETWORKING AND SOCIALIZING OPPORTUNITIES FOR BUSINESS PURPOSES; BUSINESS ADVISORY SERVICES, NAMELY, SEARCH FOR AND SELECTION OF THE BEST POTENTIAL SUPPLIERS FOR OTHERS; INTERNET ADVERTISING SERVICES; PROMOTING THE GOODS AND SERVICES OF OTHERS THROUGH SEARCH ENGINE REFERRAL TRAFFIC ANALYSIS AND REPORTING; PROMOTIONAL SERVICES, NAMELY, PROVIDING A WEB-BASED SYSTEM AND ONLINE PORTALS IN THE FIELD OF CONSUMER-TO-BUSINESS COMMERCE FOR CONSUMERS TO ENTER, MANAGE AND MODIFY THEIR CONSUMER PREFERENCE INFORMATION FOR USE BY MERCHANTS TO CREATE AND MANAGE OFFERS FOR DELIVERY TO CONSUMERS; PROVIDING ADVERTISING SERVICE TO DISTRIBUTE ADVERTISEMENTS FOR DISPLAY ON INTERNET, NAMELY, IN WEBSITES, SOCIAL CONVERSATIONS OVER THE INTERNET, EMAILS, MICROBLOGS, BLOGS, ELECTRONIC MESSAGES, INSTANT MESSAGES, TEXT MESSAGES, MULTIMEDIA MESSAGES, SOCIAL NETWORKS, STATUS UPDATES, FORUMS, ELECTRONIC BULLETIN BOARDS (U.S. CLS. 100, 101 AND 102).

FIRST USE 3-1-2011; IN COMMERCE 3-1-2011.

CLASS 45—PERSONAL AND LEGAL SERVICES

FOR INTERNET-BASED SOCIAL NETWORKING SERVICES; PROVIDING ON-LINE COMPUTER DATABASES AND ON-LINE SEARCHABLE DATABASES IN THE FIELD OF SOCIAL NETWORKING (U.S. CLS. 100 AND 101).

FIRST USE 3-1-2011; IN COMMERCE 3-1-2011.

4,016,832. BIOMED REALTY TRUST, INC., SAN DIEGO, CA.
SN 85-044,194. PUB. 10-19-2010, FILED 5-20-2010.

**THE ONLY INVESTMENT GRADE
REIT EXCLUSIVELY DEDICATED
TO THE LIFE SCIENCE
INDUSTRY**

THE MARK CONSISTS OF STANDARD CHARACTERS WITHOUT CLAIM TO ANY PARTICULAR FONT, STYLE, SIZE, OR COLOR.

CLASS 36—INSURANCE AND FINANCIAL

FOR REAL ESTATE ACQUISITION, LEASING, AND MANAGEMENT SERVICES; REAL ESTATE INVESTMENT SERVICES; REAL ESTATE INVESTMENT TRUST SERVICES (U.S. CLS. 100, 101 AND 102).

FIRST USE 6-6-2011; IN COMMERCE 6-6-2011.

CLASS 37—CONSTRUCTION AND REPAIR

FOR REAL ESTATE DEVELOPMENT (U.S. CLS. 100, 103 AND 106).

FIRST USE 6-6-2011; IN COMMERCE 6-6-2011.

4,016,833. BIOMED REALTY TRUST, INC., SAN DIEGO, CA. SN 85-044,197. PUB. 10-19-2010, FILED 5-20-2010.

4,016,836. THE URBAN ALTERNATIVE, DALLAS, TX. SN 85-045,374. PUB. 11-9-2010, FILED 5-21-2010.

THE INVESTMENT GRADE REIT
DEDICATED TO THE LIFE
SCIENCE INDUSTRY

THE MARK CONSISTS OF STANDARD CHARACTERS WITHOUT CLAIM TO ANY PARTICULAR FONT, STYLE, SIZE, OR COLOR.

CLASS 36—INSURANCE AND FINANCIAL

FOR REAL ESTATE ACQUISITION, LEASING, AND MANAGEMENT SERVICES; REAL ESTATE INVESTMENT SERVICES; REAL ESTATE INVESTMENT TRUST SERVICES (U.S. CLS. 100, 101 AND 102).
FIRST USE 6-6-2011; IN COMMERCE 6-6-2011.

CLASS 37—CONSTRUCTION AND REPAIR

FOR REAL ESTATE DEVELOPMENT (U.S. CLS. 100, 103 AND 106).
FIRST USE 6-6-2011; IN COMMERCE 6-6-2011.

4,016,834. BOAS GROUP, INC., THE, ATLANTA, GA. SN 85-044,778. PUB. 10-19-2010, FILED 5-21-2010.

SHEDDING THE BITCH

THE MARK CONSISTS OF STANDARD CHARACTERS WITHOUT CLAIM TO ANY PARTICULAR FONT, STYLE, SIZE, OR COLOR.

CLASS 16—PAPER GOODS AND PRINTED MATTER

FOR SERIES OF NON-FICTION BOOKS IN THE FIELD OF PERSONAL DEVELOPMENT (U.S. CLS. 2, 5, 22, 23, 29, 37, 38 AND 50).
FIRST USE 3-15-2011; IN COMMERCE 3-15-2011.

CLASS 41—EDUCATION AND ENTERTAINMENT

FOR CONDUCTING WORKSHOPS AND SEMINARS IN PERSONAL DEVELOPMENT; ENTERTAINMENT SERVICES, NAMELY, CONDUCTING PARTIES; PERSONAL COACHING SERVICES IN THE FIELD OF PERSONAL DEVELOPMENT; PROVIDING GROUP COACHING IN THE FIELD OF PERSONAL DEVELOPMENT (U.S. CLS. 100, 101 AND 107).
FIRST USE 3-27-2010; IN COMMERCE 5-12-2010.

Kingdom Agenda Ministries

THE MARK CONSISTS OF STANDARD CHARACTERS WITHOUT CLAIM TO ANY PARTICULAR FONT, STYLE, SIZE, OR COLOR.

NO CLAIM IS MADE TO THE EXCLUSIVE RIGHT TO USE "MINISTRIES", APART FROM THE MARK AS SHOWN.

CLASS 41—EDUCATION AND ENTERTAINMENT

FOR EDUCATIONAL SERVICES, NAMELY, CONDUCTING CLASSES, SEMINARS, WORKSHOPS AND CONFERENCES IN THE FIELD OF RELIGION, CHRISTIAN EDUCATION, LEADERSHIP TRAINING, MINISTRY DEVELOPMENT, SPIRITUAL GROWTH, FAMILY VALUES, YOUTH DEVELOPMENT, MENTORING SERVICES AND COMMUNITY OUTREACH AND DISTRIBUTION OF PRINTED MATERIALS IN CONNECTION THEREWITH IN HARD COPY OR ELECTRONIC FORMAT ON THE SAME TOPICS (U.S. CLS. 100, 101 AND 107).
FIRST USE 6-1-2011; IN COMMERCE 6-1-2011.

CLASS 45—PERSONAL AND LEGAL SERVICES

FOR EVANGELISTIC AND MINISTERIAL SERVICES; PROVIDING A WEB SITE FEATURING INFORMATION ABOUT RELIGION; PROVIDING A WEBSITE FEATURING INFORMATION ABOUT MINISTERIAL SERVICES (U.S. CLS. 100 AND 101).
FIRST USE 6-1-2011; IN COMMERCE 6-1-2011.

4,016,839. JOHNSON & JOHNSON, NEW BRUNSWICK, NJ. SN 85-046,924. PUB. 10-26-2010, FILED 5-25-2010.

MINERALBLOCK

THE MARK CONSISTS OF THE STYLIZED WORD "MINERALBLOCK" WITH THE LETTER "O" CONTAINING A SUN DESIGN.

CLASS 3—COSMETICS AND CLEANING PREPARATIONS

FOR SUN CARE PREPARATIONS (U.S. CLS. 1, 4, 6, 50, 51 AND 52).
FIRST USE 12-14-2010; IN COMMERCE 12-14-2010.

CLASS 5—PHARMACEUTICALS

FOR MEDICATED SUN CARE PREPARATIONS (U.S. CLS. 6, 18, 44, 46, 51 AND 52).
FIRST USE 12-14-2010; IN COMMERCE 12-14-2010.

4,016,849. STROM, LEX, DBA LEXCALIBURS, CASTLE ROCK, WA. SN 85-049,505. PUB. 11-9-2010, FILED 5-27-2010.



THE COLOR(S) BLACK, WHITE, GOLD, AND BURGUNDY IS/ARE CLAIMED AS A FEATURE OF THE MARK.

THE MARK CONSISTS OF A HAND WEARING A BLACK AND WHITE GAUNTLET HOLDING A BURGUNDY, GOLD, AND WHITE STRIPED HANDLE OF A SWORD WITH A GOLD AND WHITE BLADE, WHERE THE WORD "LEXCALIBURS" IN GOLD FORMS PART OF THE SWORD BLADE.

CLASS 6—METAL GOODS

FOR NON-LUMINOUS AND NON-MECHANICAL METAL SIGNS (U.S. CLS. 2, 12, 13, 14, 23, 25 AND 50).
FIRST USE 5-0-2010; IN COMMERCE 5-0-2010.

CLASS 9—ELECTRICAL AND SCIENTIFIC APPARATUS

FOR VIDEO DISKS FEATURING INSTRUCTIONS AND TRAINING FOR PHYSICAL FITNESS, BIOMECHANICS TECHNIQUES, AND IMPROVED ATHLETIC PERFORMANCE (U.S. CLS. 21, 23, 26, 36 AND 38).
FIRST USE 5-1-2010; IN COMMERCE 5-1-2010.

CLASS 16—PAPER GOODS AND PRINTED MATTER

FOR LOG BOOKS (U.S. CLS. 2, 5, 22, 23, 29, 37, 38 AND 50).
FIRST USE 5-0-2010; IN COMMERCE 5-0-2010.

CLASS 25—CLOTHING

FOR ATHLETIC APPAREL, NAMELY, SHIRTS, PANTS, JACKETS, FOOTWEAR, HATS AND CAPS, ATHLETIC UNIFORMS (U.S. CLS. 22 AND 39).
FIRST USE 5-1-2010; IN COMMERCE 5-1-2010.

CLASS 41—EDUCATION AND ENTERTAINMENT

FOR PERSONAL TRAINING SERVICES, NAMELY, STRENGTH AND CONDITIONING TRAINING; PROVIDING SPORTS FACILITIES (U.S. CLS. 100, 101 AND 107).
FIRST USE 5-0-2010; IN COMMERCE 5-0-2010.

4,016,853. SARE, MICHELE V., DBA NURSES FOR NURSES INTERNATIONAL, HALL, MT. SN 85-051,221. PUB. 11-2-2010, FILED 5-31-2010.

JOIN
Journal of International
Nursing

THE MARK CONSISTS OF STANDARD CHARACTERS WITHOUT CLAIM TO ANY PARTICULAR FONT, STYLE, SIZE, OR COLOR.
NO CLAIM IS MADE TO THE EXCLUSIVE RIGHT TO

USE "JOURNAL OF INTERNATIONAL NURSING", APART FROM THE MARK AS SHOWN.

CLASS 35—ADVERTISING AND BUSINESS

FOR SUBSCRIPTIONS TO ELECTRONIC JOURNALS (U.S. CLS. 100, 101 AND 102).
FIRST USE 5-31-2010; IN COMMERCE 5-31-2010.

CLASS 41—EDUCATION AND ENTERTAINMENT

FOR MULTIMEDIA PUBLISHING OF BOOKS, MAGAZINES, JOURNALS, SOFTWARE, GAMES, MUSIC, AND ELECTRONIC PUBLICATIONS; ON-LINE JOURNALS, NAMELY, BLOGS FEATURING TRENDS AND ISSUES IN INTERNATIONAL NURSING.; PROVIDING CONTINUING NURSING EDUCATION COURSES; PUBLICATION OF BOOKS, OF MAGAZINES, OF JOURNALS, OF NEWSPAPERS, OF PERIODICALS, OF CATALOGS, OF BROCHURES; WRITING OF ARTICLES FOR JOURNALS OTHER THAN FOR ADVERTISING OR PUBLICITY; WRITING OF ARTICLES FOR PROFESSIONAL JOURNALS OTHER THAN FOR ADVERTISING OR PUBLICITY (U.S. CLS. 100, 101 AND 107).
FIRST USE 5-31-2010; IN COMMERCE 5-31-2010.

4,016,855. BATH & BODY WORKS BRAND MANAGEMENT, INC., REYNOLDSBURG, OH. SN 85-052,434. PUB. 10-26-2010, FILED 6-2-2010.

SECRET WONDERLAND

THE MARK CONSISTS OF STANDARD CHARACTERS WITHOUT CLAIM TO ANY PARTICULAR FONT, STYLE, SIZE, OR COLOR.

CLASS 3—COSMETICS AND CLEANING PREPARATIONS

FOR PERSONAL CARE PRODUCTS, NAMELY, ANTI-BACTERIAL SKIN SOAPS, BATH FOAMS, BATH GELS, BATH LOTION, BATH OILS FOR COSMETIC PURPOSES, BATH SALTS, BATH SOAPS IN LIQUID, SOLID OR GEL FORM, BODY CREAM SOAP, BODY CREAMS, BODY LOTIONS, BODY OILS, BODY POWDER, BODY SCRUB, BODY SPRAY USED AS A PERSONAL DEODORANT AND AS FRAGRANCE, BODY SPRAYS, NAMELY, WATER IN ATOMIZED CONTAINERS USED TO PRODUCE A COOLING EFFECT, BODY WASHES FOR HUMANS, BUBBLE BATH, COLOGNE, HAIR CONDITIONERS, CREAM SOAPS, EAU DE PARFUM, EAU DE TOILETTE, ESSENTIAL OILS FOR PERSONAL USE, EXFOLIANT CREAMS, EXFOLIANTS FOR SKIN, FACE AND BODY CREAMS, FACE AND BODY GLITTER, FACE AND BODY LOTIONS, FACE POWDER, FACIAL BEAUTY MASKS, FACIAL CLEANSERS, FACIAL SCRUBS, FOAM BATH, FRAGRANCE EMITTING WICKS FOR ROOM FRAGRANCE, FRAGRANCES FOR AUTOMOBILES, FRAGRANCES FOR PERSONAL USE, HAIR CARE CREAMS, HAIR CARE KITS COMPRISING NON-MEDICATED HAIR CARE PREPARATIONS, NAMELY, SHAMPOO AND CONDITIONER, HAIR CONDITIONERS, HAIR GELS, HAIR POMADES, HAIR SHAMPOO, HAIR TONICS, HAND CLEANSERS, HAND CREAMS, HAND LOTIONS, HAND SOAPS, LIP BALM, LIP CREAM, LIP GLOSS, LIP GLOSS PALATTE, LIP POLISHER, LIQUID SOAPS FOR HANDS, FACE AND BODY, MASSAGE OILS, MEDICATED SOAPS, MOISTURIZING CREAMS, MOUSSE FOR HAIR, NON-MEDICATED BODY SOAKS, NON-MEDICATED FOOT CREAM, PERFUME, PERFUME OILS, PERFUMED SOAPS, ROOM FRAGRANCE REFILLS FOR NON-ELECTRIC ROOM FRAGRANCE DISPENSERS, ROOM FRAGRANCES, SCENTED BODY SPRAY, SCENTED LINEN SPRAYS, SCENTED OILS USED TO PRODUCE AROMAS WHEN HEATED, SCENTED ROOM SPRAYS, SHAVING CREAMS, SHAVING FOAMS, SHAVING GELS, SHAVING LOTIONS, SHOWER AND BATH FOAM, SHOWER CREAMS, SHOWER GELS, SKIN CLEANSERS, SKIN LOTIONS, SKIN MASKS, SKIN MOISTURIZER, SKIN SOAP, SKIN TONERS, HOME FRAGRANCE OILS AND FRAGRANCE REEDS SOLD AS A UNIT, FRAGRANT ROOM SPRAY (U.S. CLS. 1, 4, 6, 50, 51 AND 52).
FIRST USE 9-27-2010; IN COMMERCE 9-27-2010.

CLASS 4—LUBRICANTS AND FUELS

FOR CANDLES (U.S. CLS. 1, 6 AND 15).
FIRST USE 9-27-2010; IN COMMERCE 9-27-2010.

4,016,857. RED APPLE AUCTIONS CO., ALEXANDRIA, VA.
SN 85-052,587. PUB. 11-23-2010, FILED 6-2-2010.

RED APPLE AUCTIONS

THE MARK CONSISTS OF STANDARD CHARACTERS WITHOUT CLAIM TO ANY PARTICULAR FONT, STYLE, SIZE, OR COLOR.

NO CLAIM IS MADE TO THE EXCLUSIVE RIGHT TO USE "AUCTIONS", APART FROM THE MARK AS SHOWN.

CLASS 35—ADVERTISING AND BUSINESS

FOR ARRANGING AND CONDUCTING AUCTIONS; CONSULTING SERVICES IN THE FIELD OF AUCTIONEERING; PROVIDING INFORMATION IN THE FIELD OF AUCTIONS VIA AN ONLINE WEB SITE ACCESSIBLE THROUGH A GLOBAL COMPUTER NETWORK (U.S. CLS. 100, 101 AND 102).
FIRST USE 1-31-2006; IN COMMERCE 1-31-2006.

CLASS 41—EDUCATION AND ENTERTAINMENT

FOR PUBLICATION OF PRINTED MATTER IN THE FIELD OF AUCTIONS; EDUCATIONAL SERVICES, NAMELY, CONDUCTING TRAINING, WORKSHOPS, TELECLASSES, PODCASTS AND WEBINARS IN THE FIELD OF AUCTIONS (U.S. CLS. 100, 101 AND 107).
FIRST USE 1-31-2006; IN COMMERCE 1-31-2006.

4,016,861. WILLIAMS, FAYE, AUTRYVILLE, NC. SN 85-053,423. PUB. 11-2-2010, FILED 6-3-2010.

GYPSY M16

THE MARK CONSISTS OF STANDARD CHARACTERS WITHOUT CLAIM TO ANY PARTICULAR FONT, STYLE, SIZE, OR COLOR.

CLASS 9—ELECTRICAL AND SCIENTIFIC APPARATUS

FOR PRE-RECORDED CDS FEATURING MUSIC; PRE-RECORDED ELECTRONIC AND DIGITAL MEDIA FEATURING MUSIC (U.S. CLS. 21, 23, 26, 36 AND 38).
FIRST USE 6-14-2011; IN COMMERCE 6-14-2011.

CLASS 41—EDUCATION AND ENTERTAINMENT

FOR ENTERTAINMENT SERVICES IN THE NATURE OF LIVE MUSICAL PERFORMANCES (U.S. CLS. 100, 101 AND 107).
FIRST USE 6-14-2011; IN COMMERCE 6-14-2011.

4,016,863. THOMAS PUBLISHING COMPANY, NEW YORK, NY. SN 85-053,797. PUB. 3-1-2011, FILED 6-3-2010.

THOMASNET WEB SOLUTIONS

THE MARK CONSISTS OF STANDARD CHARACTERS WITHOUT CLAIM TO ANY PARTICULAR FONT, STYLE, SIZE, OR COLOR.

OWNER OF U.S. REG. NOS. 2,232,798, 3,395,016, AND 3,408,008.

NO CLAIM IS MADE TO THE EXCLUSIVE RIGHT TO USE "WEB SOLUTIONS", APART FROM THE MARK AS SHOWN.

CLASS 35—ADVERTISING AND BUSINESS

FOR BUSINESS MONITORING SERVICES, NAMELY, TRACKING WEB SITES OF OTHERS TO PROVIDE DETAILS ABOUT USER CLICK TRAFFIC OR VISITS TO THE WEB SITE (U.S. CLS. 100, 101 AND 102).
FIRST USE 4-14-2006; IN COMMERCE 4-14-2006.

CLASS 42—SCIENTIFIC AND COMPUTER SERVICES

FOR SOFTWARE AS A SERVICE (SAAS) SERVICES FEATURING SOFTWARE IN THE FIELD OF CONTENT MANAGEMENT FOR WEBSITES; SOFTWARE AS A SERVICE (SAAS) SERVICES FEATURING SOFTWARE ENABLING SEARCHING ONLINE CATALOGS AND DATABASES OF INDUSTRIAL PRODUCTS AND SERVICES VIA KEYWORDS, PART NUMBERS, AND PARAMETRIC SEARCHING AND THAT PROVIDES FOR COMPARISONS BETWEEN PRODUCTS; SOFTWARE AS A SERVICE (SAAS) SERVICES FEATURING SOFTWARE THAT ENABLES USERS TO CONFIGURE A PRODUCT FOR PURCHASE ACCORDING TO THE USER'S PRODUCT REQUIREMENTS; SOFTWARE AS A SERVICE (SAAS) SERVICES FEATURING SOFTWARE IN THE FIELD OF ENABLING USERS TO VIEW AND MANIPULATE 2D AND 3D CAD DRAWINGS ONLINE, DOWNLOAD AND INSERT 2D AND 3D CAD DRAWINGS FROM WEBSITES INTO THEIR OWN DESIGNS OR E-MAIL CAD DRAWINGS; SOFTWARE AS A SERVICE (SAAS) SERVICES FEATURING E-COMMERCE SOFTWARE TO ALLOW USERS TO PERFORM ELECTRONIC BUSINESS TRANSACTIONS VIA A GLOBAL COMPUTER NETWORK; SOFTWARE AS A SERVICE (SAAS) SERVICES FEATURING SOFTWARE FOR INTEGRATING ONLINE ORDERING INTO INTERNAL ORDERING, BILLING AND FULFILLMENT SYSTEMS; SOFTWARE AS A SERVICE (SAAS) SERVICES FEATURING SOFTWARE FOR CHECKING CUSTOMER PRICING, CONFIRMING SHIP-TO AND BILLING INFORMATION AND REVIEWING INVENTORY AVAILABILITY; COMPUTER SERVICES, NAMELY, SEARCH ENGINE OPTIMIZATION; PROVIDING CUSTOMIZED ON-LINE WEB PAGES FEATURING USER-DEFINED INFORMATION, WHICH INCLUDES SEARCH ENGINES AND ON-LINE WEB LINKS TO OTHER WEB SITES; WEBSITE DESIGN AND DEVELOPMENT FOR OTHERS; SOFTWARE AS A SERVICE (SAAS) SERVICES FEATURING SOFTWARE FOR SYNDICATING CONTENT TO SPECIFIED WEBSITES (U.S. CLS. 100 AND 101).

FIRST USE 4-14-2006; IN COMMERCE 4-14-2006.

4,016,870. ERHUNMWUNSE, GIBSON, ALEXANDRIA, VA.
SN 85-055,044. PUB. 11-2-2010, FILED 6-4-2010.

DOMAIN MEDICAL HOME HEALTH
& STAFFING

THE MARK CONSISTS OF STANDARD CHARACTERS WITHOUT CLAIM TO ANY PARTICULAR FONT, STYLE, SIZE, OR COLOR.

NO CLAIM IS MADE TO THE EXCLUSIVE RIGHT TO USE "MEDICAL HOME HEALTH & STAFFING", APART FROM THE MARK AS SHOWN.

CLASS 44—MEDICAL, BEAUTY AND AGRICULTURAL SERVICES

FOR HOME HEALTH CARE SERVICES; NURSING SERVICES; PHYSICAL THERAPY; OCCUPATIONAL THERAPY SERVICES; REHABILITATION PATIENT CARE SERVICES; SPEECH PATHOLOGY THERAPY SERVICES; DIET AND NUTRITION COUNSELING AND SUPERVISING (U.S. CLS. 100 AND 101).

FIRST USE 4-26-2011; IN COMMERCE 4-26-2011.

CLASS 45—PERSONAL AND LEGAL SERVICES

FOR NON-MEDICAL IN-HOME PERSONAL CARE ASSISTANCE OF ACTIVITIES OF DAILY LIFE, SUCH AS BATHING, DRESSING, GROOMING, PERSONAL HYGIENE, MEAL PREPARATION, RUNNING ERRANDS AND PERSONAL SHOPPING FOR OTHERS, AND PERSONAL MOBILITY FOR MENTALLY OR PHYSICALLY CHALLENGED PEOPLE; COMPANIONSHIP SERVICES FOR THE ELDERLY, HANDICAPPED AND HOME-BOUND; RESPITE FOR FAMILIES OF PATIENTS WITH MEDICAL NEED, NAMELY, COMPANIONSHIP, HELP WITH MEDICAL FORMS, EMOTIONAL COUNSELING AND EMOTIONAL SUPPORT (U.S. CLS. 100 AND 101).

FIRST USE 4-26-2011; IN COMMERCE 4-26-2011.

4,016,887. BIONAN HEALTHCARE, INC., PORT ST. LUCIE,
FL. SN 85-060,431. PUB. 11-9-2010, FILED 6-11-2010.

BIONAN

THE MARK CONSISTS OF STANDARD CHARACTERS WITHOUT CLAIM TO ANY PARTICULAR FONT, STYLE, SIZE, OR COLOR.

CLASS 5—PHARMACEUTICALS

FOR DRUG DELIVERY AGENTS CONSISTING OF COMPOUNDS THAT FACILITATE DELIVERY OF A WIDE RANGE OF PHARMACEUTICALS; MEDICINAL PREPARATIONS FOR THE MOUTH AND AS SPRAYS; PHARMACEUTICAL PREPARATIONS AND SUBSTANCES FOR THE TREATMENT OF VIRAL, METABOLIC, ENDOCRINE, MUSCULOSKELETAL, CARDIOVASCULAR, CARDIOPULMONARY, GENITOURINARY, SEXUAL DYSFUNCTION, ONCOLOGICAL, HEPATOLOGICAL, OPHTHALMIC, RESPIRATORY, NEUROLOGICAL, GASTROINTESTINAL, HORMONAL, DERMATOLOGICAL, PSYCHIATRIC AND IMMUNE SYSTEM RELATED DISEASES AND DISORDERS; PHARMACEUTICAL PREPARATIONS FOR THE PREVENTION AND TREATMENT OF DISORDERS OF THE NERVOUS SYSTEM, THE IMMUNE SYSTEM, THE CARDIO-VASCULAR SYSTEM, THE METABOLIC SYSTEM, THE RESPIRATORY SYSTEM, THE MUSCULO-SKELETAL SYSTEM, THE GENITOURINARY SYSTEM; FOR THE TREATMENT OF INFLAMMATORY DISORDERS; FOR USE IN DERMATOLOGY, ONCOLOGY, HEMATOLOGY AND IN TISSUE AND ORGAN TRANSPLANTATION, IN OPHTHALMOLOGY AND FOR GASTROENTEROLOGICAL DISORDERS; PHARMACEUTICAL PREPARATIONS FOR THE PREVENTION AND TREATMENT OF OCULAR DISORDERS OR DISEASES, BACTERIA-BASED DISEASES OR DISORDERS, AUTOIMMUNE DISEASES OR DISORDERS, KIDNEY DISEASES OR DISORDERS, AND DIABETES (U.S. CLS. 6, 18, 44, 46, 51 AND 52).

FIRST USE 6-18-2010; IN COMMERCE 6-18-2010.

CLASS 42—SCIENTIFIC AND COMPUTER SERVICES

FOR PHARMACEUTICAL DRUG DEVELOPMENT SERVICES; PHARMACEUTICAL PRODUCT EVALUATION; PHARMACEUTICAL RESEARCH AND DEVELOPMENT; PHARMACEUTICAL RESEARCH SERVICES (U.S. CLS. 100 AND 101).

FIRST USE 8-28-2009; IN COMMERCE 8-28-2009.

4,016,893. SOCIAL CONCEPTS, INC., REDWOOD CITY, CA.
SN 85-060,981. PUB. 11-9-2010, FILED 6-11-2010.

FLECK

THE MARK CONSISTS OF STANDARD CHARACTERS WITHOUT CLAIM TO ANY PARTICULAR FONT, STYLE, SIZE, OR COLOR.

CLASS 9—ELECTRICAL AND SCIENTIFIC APPARATUS

FOR COMPUTER GAME PROGRAMS; DOWNLOADABLE VIDEO GAME SOFTWARE AVAILABLE THROUGH THE INTERNET; COMPUTER GAME SOFTWARE; COMPUTER SOFTWARE FOR WIRELESS CONTENT DELIVERY; ELECTRONIC GAME PROGRAMS; ELECTRONIC GAME SOFTWARE FOR CELLULAR TELEPHONES; ELECTRONIC GAMES SOFTWARE FOR HANDHELD ELECTRONIC DEVICE; ELECTRONIC GAME SOFTWARE FOR WIRELESS DEVICES; INTERACTIVE MULTIMEDIA COMPUTER GAME PROGRAM; INTERACTIVE VIDEO GAME PROGRAMS (U.S. CLS. 21, 23, 26, 36 AND 38).

FIRST USE 6-30-2010; IN COMMERCE 6-30-2010.

CLASS 41—EDUCATION AND ENTERTAINMENT

FOR ENTERTAINMENT SERVICES, NAMELY, PROVIDING ON-LINE COMPUTER GAMES (U.S. CLS. 100, 101 AND 107).

FIRST USE 6-30-2010; IN COMMERCE 6-30-2010.

CLASS 42—SCIENTIFIC AND COMPUTER SERVICES

FOR PROVIDING A WEBSITE FEATURING PRIMARY NON-DOWNLOADABLE SOFTWARE FOR INTERNET BASED SOCIAL NETWORKING AND ON-LINE VIDEO GAMES (U.S. CLS. 100 AND 101).

FIRST USE 6-30-2010; IN COMMERCE 6-30-2010.

CLASS 45—PERSONAL AND LEGAL SERVICES

FOR INTERNET-BASED SOCIAL NETWORKING SERVICE (U.S. CLS. 100 AND 101).

FIRST USE 6-30-2010; IN COMMERCE 6-30-2010.

4,016,912. INIZIO ENTERTAINMENT, LLC, ST CHARLES, IL. SN 85-066,315. PUB. 11-16-2010, FILED 6-18-2010.

IN PURSUIT OF PASSION

THE MARK CONSISTS OF STANDARD CHARACTERS WITHOUT CLAIM TO ANY PARTICULAR FONT, STYLE, SIZE, OR COLOR.

CLASS 9—ELECTRICAL AND SCIENTIFIC APPARATUS

FOR PRE-RECORDED DVDS FEATURING ADVENTURE AND TRAVEL; PRE-RECORDED ELECTRONIC AND DIGITAL MEDIA FEATURING ADVENTURE AND TRAVEL (U.S. CLS. 21, 23, 26, 36 AND 38).

FIRST USE 7-8-2011; IN COMMERCE 7-8-2011.

CLASS 25—CLOTHING

FOR SHORT-SLEEVED OR LONG-SLEEVED T-SHIRTS (U.S. CLS. 22 AND 39).

FIRST USE 7-8-2011; IN COMMERCE 7-8-2011.

CLASS 41—EDUCATION AND ENTERTAINMENT

FOR EDUCATIONAL AND ENTERTAINMENT SERVICES, NAMELY, A CONTINUING PROGRAM ABOUT ADVENTURE AND TRAVEL ACCESSIBLE BY RADIO, TELEVISION, SATELLITE, AUDIO, VIDEO AND COMPUTER NETWORKS (U.S. CLS. 100, 101 AND 107).

FIRST USE 7-1-2010; IN COMMERCE 7-1-2010.

4,016,915. NEW BELGIUM BREWING COMPANY, INC., FORT COLLINS, CO. SN 85-066,779. PUB. 11-16-2010, FILED 6-18-2010.

SOMERSAULT

THE MARK CONSISTS OF STANDARD CHARACTERS WITHOUT CLAIM TO ANY PARTICULAR FONT, STYLE, SIZE, OR COLOR.

CLASS 16—PAPER GOODS AND PRINTED MATTER

FOR PAPER GOODS, NAMELY, DECALS, POSTERS, PAPER COASTERS, AND POSTCARDS (U.S. CLS. 2, 5, 22, 23, 29, 37, 38 AND 50).

FIRST USE 5-2-2011; IN COMMERCE 5-2-2011.

CLASS 25—CLOTHING

FOR CLOTHING, NAMELY, SHIRTS, T-SHIRTS, SWEATSHIRTS, HATS, CAPS, JERSEYS, JACKETS, FLEECE PULLOVERS, AND SOCKS (U.S. CLS. 22 AND 39).

FIRST USE 5-2-2011; IN COMMERCE 5-2-2011.

CLASS 32—LIGHT BEVERAGES

FOR BEER (U.S. CLS. 45, 46 AND 48).

FIRST USE 5-2-2011; IN COMMERCE 5-2-2011.

4,016,917. KANTONAL LLC, MINDEN, NV. SN 85-066,890. PUB. 11-16-2010, FILED 6-18-2010.

FEEL NV?

THE MARK CONSISTS OF STANDARD CHARACTERS WITHOUT CLAIM TO ANY PARTICULAR FONT, STYLE, SIZE, OR COLOR.

CLASS 21—HOUSEWARES AND GLASS

FOR COFFEE CUPS, TEA CUPS AND MUGS, INSULATING SLEEVE HOLDERS FOR BEVERAGE CANS AND CUPS, GLASS BEVERAGEWARE (U.S. CLS. 2, 13, 23, 29, 30, 33, 40 AND 50).

FIRST USE 6-2-2011; IN COMMERCE 6-2-2011.

CLASS 25—CLOTHING

FOR CLOTHING, NAMELY, SHORT-SLEEVED OR LONG-SLEEVED T-SHIRTS, CAMISOLES, TANK TOPS, MUSCLE TOPS, SWEAT SHIRTS, HOODED SWEAT SHIRTS; HEADWEAR, NAMELY, BASEBALL CAPS AND HATS (U.S. CLS. 22 AND 39).

FIRST USE 6-2-2011; IN COMMERCE 6-2-2011.

CLASS 35—ADVERTISING AND BUSINESS

FOR CHAMBER OF COMMERCE SERVICES, NAMELY, PROMOTING BUSINESS AND TOURISM IN THE STATE OF NEVADA; CONVENTION AND VISITORS BUREAU SERVICES, NAMELY, PROMOTING TOURISM, BUSINESS AND CONVENTIONS IN AND AROUND THE STATE OF NEVADA; AND PROMOTING RECREATION AND TOURISM IN THE STATE OF NEVADA (U.S. CLS. 100, 101 AND 102).

FIRST USE 5-27-2011; IN COMMERCE 5-27-2011.

4,016,925. WASTE MANAGEMENT, INC., HOUSTON, TX. SN 85-068,050. PUB. 11-16-2010, FILED 6-21-2010.

SMARTENERGY

THE MARK CONSISTS OF STANDARD CHARACTERS WITHOUT CLAIM TO ANY PARTICULAR FONT, STYLE, SIZE, OR COLOR.

CLASS 37—CONSTRUCTION AND REPAIR

FOR WASTE DISPOSAL FOR OTHERS; COLLECTION OF TRASH (U.S. CLS. 100, 103 AND 106).

FIRST USE 7-11-2011; IN COMMERCE 7-11-2011.

CLASS 39—TRANSPORTATION AND STORAGE

FOR GARBAGE COLLECTION (U.S. CLS. 100 AND 105).

FIRST USE 7-11-2011; IN COMMERCE 7-11-2011.

4,016,931. VANI U.S.A., INC., NEW YORK, NY. SN 85-068,827. PUB. 12-28-2010, FILED 6-22-2010.



OWNER OF U.S. REG. NO. 3,694,079.

NO CLAIM IS MADE TO THE EXCLUSIVE RIGHT TO USE "NEW YORK", APART FROM THE MARK AS SHOWN.

THE NAME "ANAIS GVANI" DOES NOT IDENTIFY A LIVING INDIVIDUAL.

THE MARK CONSISTS OF A DESIGN-LIKE STYLIZED WORDING "AG" CONNECTED TO EACH OTHER. THE WORDS BENEATH IT READ "ANAIS GVANI NEW YORK".

CLASS 9—ELECTRICAL AND SCIENTIFIC APPARATUS

FOR EYEWEAR, NAMELY, EYEGLASSES, SUNGLASSES, OPTICAL GLASSES, MAGNIFYING GLASSES, CONTACT LENSES; EYEWEAR ACCESSORIES, STRAPS, NECK CORDS, HEAD STRAPS, EYEWEAR CASES, CASES FOR SPECTACLES AND CONTACT LENSES, NOSE GUARDS, EYEGLASS CHAINS, EYEGLASS FRAMES, EYEGLASS LENSES, MAGNIFYING LENSES, OPTICAL FRAMES, SUNGLASSES LENSES, OPTICAL LENSES; EYEWEAR RETAINERS; PROTECTIVE EYEWEAR AND COMPONENT PARTS THEREOF (U.S. CLS. 21, 23, 26, 36 AND 38).

FIRST USE 3-18-2008; IN COMMERCE 3-18-2008.

CLASS 14—JEWELRY

FOR JEWELRY AND IMITATION JEWELRY, NAMELY, BRACELETS, CHARMS, COSTUME JEWELRY, JADE, PRECIOUS STONES, JEWELRY CASES, JEWELRY CASKETS, JEWELRY BOXES, JEWELRY CHAINS, JEWELRY PLATED WITH PRECIOUS METALS, JEWELRY FOR ATTACHMENT TO CLOTHING, JEWELRY ORGANIZERS, JEWELRY PINS FOR USE ON HATS, JEWELRY RING HOLDERS, CUFFS, CROSSES, MAGNETIC PENDANTS, MAGNETIC NECKLACES, STONE PENDANTS, KEY CHAINS, LAPEL PINS, NECKLACES, PEARLS, PETS JEWELRY, PINS, PLASTIC BRACELETS IN THE NATURE OF JEWELRY, PRECIOUS AND SEMI-PRECIOUS CRYSTAL STONES AND BEADS FOR USE IN JEWELRY, RINGS, STAINLESS STEEL JEWELRY BRACELETS, AND WATCHES AND CLOCKS (U.S. CLS. 2, 27, 28 AND 50).

FIRST USE 3-18-2008; IN COMMERCE 3-18-2008.

4,016,933. CONAIR CORPORATION, STAMFORD, CT. SN 85-069,722. PUB. 10-26-2010, FILED 6-23-2010.

ENTICE

THE MARK CONSISTS OF STANDARD CHARACTERS WITHOUT CLAIM TO ANY PARTICULAR FONT, STYLE, SIZE, OR COLOR.

CLASS 9—ELECTRICAL AND SCIENTIFIC APPARATUS

FOR ELECTRIC HAND-HELD HAIR STYLING IRONS (U.S. CLS. 21, 23, 26, 36 AND 38).
FIRST USE 7-20-2010; IN COMMERCE 7-20-2010.

CLASS 11—ENVIRONMENTAL CONTROL APPARATUS

FOR HAND-HELD ELECTRIC HAIR DRYERS (U.S. CLS. 13, 21, 23, 31 AND 34).
FIRST USE 11-4-2010; IN COMMERCE 11-4-2010.

4,016,934. KATZ, RICHARD, RANCHO SANTA MARGARITA, CA. SN 85-070,108. PUB. 11-16-2010, FILED 6-23-2010.

PrepTech

THE MARK CONSISTS OF STANDARD CHARACTERS WITHOUT CLAIM TO ANY PARTICULAR FONT, STYLE, SIZE, OR COLOR.

CLASS 8—HAND TOOLS

FOR CUTLERY, NAMELY, FORKS, SPOONS, AND KNIVES (U.S. CLS. 23, 28 AND 44).
FIRST USE 1-12-2011; IN COMMERCE 1-12-2011.

CLASS 21—HOUSEWARES AND GLASS

FOR CHOPPING BOARDS FOR KITCHEN USE; CUTTING BOARDS (U.S. CLS. 2, 13, 23, 29, 30, 33, 40 AND 50).
FIRST USE 1-12-2011; IN COMMERCE 1-12-2011.

4,016,937. OWN YOUR MONEY LLC, SOUTH BOSTON, MA. SN 85-070,212. PUB. 11-16-2010, FILED 6-23-2010.

OWN YOUR MONEY

THE MARK CONSISTS OF STANDARD CHARACTERS WITHOUT CLAIM TO ANY PARTICULAR FONT, STYLE, SIZE, OR COLOR.

CLASS 9—ELECTRICAL AND SCIENTIFIC APPARATUS

FOR DIGITAL MATERIALS, NAMELY, CDS AND DOWNLOADABLE AUDIO FILES FEATURING FINANCIAL ADVICE (U.S. CLS. 21, 23, 26, 36 AND 38).
FIRST USE 12-10-2009; IN COMMERCE 12-19-2009.

CLASS 35—ADVERTISING AND BUSINESS

FOR ADVICE IN THE FIELD OF BUSINESS MANAGEMENT AND MARKETING; BUSINESS CONSULTATION (U.S. CLS. 100, 101 AND 102).
FIRST USE 1-0-2008; IN COMMERCE 1-0-2008.

CLASS 36—INSURANCE AND FINANCIAL

FOR FINANCIAL ADVICE AND CONSULTANCY SERVICES (U.S. CLS. 100, 101 AND 102).
FIRST USE 11-0-2007; IN COMMERCE 11-0-2007.

CLASS 41—EDUCATION AND ENTERTAINMENT

FOR EDUCATION SERVICES, NAMELY, PROVIDING SEMINARS, TELECLASSES, SPEECHES, TRAINING PROGRAMS, AND WORKSHOPS IN THE FIELDS OF FINANCIAL MANAGEMENT, PERSONAL FINANCE, AND FINANCIAL EMPOWERMENT; ENTERTAINMENT SERVICES, NAMELY, THE PROVISION OF CONTINUING EDUCATIONAL RADIO SHOW SEGMENTS FEATURING FINANCIAL AND BUSINESS ADVICE DELIVERED BY RADIO; ON-LINE JOURNALS, NAMELY, BLOGS FEATURING FINANCIAL AND BUSINESS ADVICE; PERSONAL COACHING SERVICES IN THE FIELD OF FINANCIAL MANAGEMENT, PERSONAL FINANCE, AND FINANCIAL EMPOWERMENT; PROFESSIONAL COACHING SERVICES IN THE FIELD OF BUSINESS FINANCE, BUSINESS OPERATION, AND BUSINESS MANAGEMENT; PROVIDING ON-LINE NEWSLETTERS IN THE FIELD OF FINANCIAL AND BUSINESS ADVICE; EDUCATIONAL SERVICES, NAMELY, PROVIDING A CONTINUING PRERECORDED AUDIO PROGRAM IN THE FIELD OF FINANCIAL AND BUSINESS ADVICE ACCESSIBLE OVER THE INTERNET (U.S. CLS. 100, 101 AND 107).
FIRST USE 11-0-2007; IN COMMERCE 11-0-2007.

4,016,939. FURMINATOR, INC., FENTON, MO. SN 85-070,906. PUB. 11-16-2010, FILED 6-24-2010.

YOU'VE GOT TO BE SHEDDING ME

THE MARK CONSISTS OF STANDARD CHARACTERS WITHOUT CLAIM TO ANY PARTICULAR FONT, STYLE, SIZE, OR COLOR.

CLASS 3—COSMETICS AND CLEANING PREPARATIONS

FOR NON-MEDICATED, NON-VETERINARY GROOMING PREPARATION, NAMELY, SHAMPOO AND HAIR CONDITIONER FOR PETS (U.S. CLS. 1, 4, 6, 50, 51 AND 52).
FIRST USE 2-24-2011; IN COMMERCE 2-24-2011.

CLASS 21—HOUSEWARES AND GLASS

FOR PET COMB, NAMELY, A GROOMING DEVICE FOR FUR BEARING ANIMALS IN THE NATURE OF A COMB-LIKE INSTRUMENT FOR REMOVAL OF THE ANIMALS' LOOSE OR SHEDDING HAIR (U.S. CLS. 2, 13, 23, 29, 30, 33, 40 AND 50).
FIRST USE 7-16-2010; IN COMMERCE 7-16-2010.

4,016,951. BATH & BODY WORKS BRAND MANAGEMENT, INC., REYNOLDSBURG, OH. SN 85-073,670. PUB. 10-26-2010, FILED 6-29-2010.

4,016,973. COUGHLAN COMPANIES, INC., MANKATO, MN. SN 85-079,859. PUB. 12-14-2010, FILED 7-7-2010.

SPARKLE SCENTPORTABLE

THE MARK CONSISTS OF STANDARD CHARACTERS WITHOUT CLAIM TO ANY PARTICULAR FONT, STYLE, SIZE, OR COLOR.

NO CLAIM IS MADE TO THE EXCLUSIVE RIGHT TO USE "SCENTPORTABLE", APART FROM THE MARK AS SHOWN.

CLASS 3—COSMETICS AND CLEANING PREPARATIONS

FOR FRAGRANCE REFILLS FOR NON-ELECTRIC ROOM AND CAR FRAGRANCE DISPENSERS, ROOM FRAGRANCE GELS, CAR FRAGRANCE GELS (U.S. CLS. 1, 4, 6, 50, 51 AND 52).

FIRST USE 11-1-2010; IN COMMERCE 11-1-2010.

CLASS 5—PHARMACEUTICALS

FOR CAR DEODORIZER, ROOM FRESHENERS (U.S. CLS. 6, 18, 44, 46, 51 AND 52).

FIRST USE 11-1-2010; IN COMMERCE 11-1-2010.

4,016,968. GARD, GERALD, MOUNT DORA, FL. SN 85-078,579. PUB. 12-21-2010, FILED 7-6-2010.



OWNER OF U.S. REG. NO. 3,841,928.

THE MARK CONSISTS OF THE WORDING "NICE RACK" AND A STYLIZED DESIGN OF A HEAD OF A DEER.

CLASS 6—METAL GOODS

FOR METAL KEY CHAINS OF NON-PRECIOUS METAL (U.S. CLS. 2, 12, 13, 14, 23, 25 AND 50).

FIRST USE 8-0-2010; IN COMMERCE 8-0-2010.

CLASS 21—HOUSEWARES AND GLASS

FOR COFFEE CUPS AND MUGS; EARTHENWARE MUGS (U.S. CLS. 2, 13, 23, 29, 30, 33, 40 AND 50).

FIRST USE 7-11-2011; IN COMMERCE 7-11-2011.

MYON

THE MARK CONSISTS OF STANDARD CHARACTERS WITHOUT CLAIM TO ANY PARTICULAR FONT, STYLE, SIZE, OR COLOR.

CLASS 9—ELECTRICAL AND SCIENTIFIC APPARATUS

FOR ELECTRONIC PUBLICATIONS, NAMELY, BOOKS, E-BOOKS AND ARTICLES FEATURING INFORMATION OF INTEREST TO CHILDREN AND YOUNG ADULTS RECORDED ON COMPUTER MEDIA (U.S. CLS. 21, 23, 26, 36 AND 38).

FIRST USE 11-1-2010; IN COMMERCE 11-1-2010.

CLASS 41—EDUCATION AND ENTERTAINMENT

FOR ON-LINE PUBLICATION OF E-BOOKS AND DIGITAL CONTENT; PROVIDING ON-LINE PUBLICATIONS IN THE NATURE OF AN E-BOOK IN THE FIELD OF BOOKS FOR YOUNG ADULTS AND CHILDREN; PUBLISHING OF BOOKS, E-BOOKS, AUDIO BOOKS, MUSIC AND ILLUSTRATIONS (U.S. CLS. 100, 101 AND 107).

FIRST USE 11-1-2010; IN COMMERCE 11-1-2010.

CLASS 42—SCIENTIFIC AND COMPUTER SERVICES

FOR CLOUD COMPUTING FEATURING SOFTWARE FOR USE IN READING E-BOOKS AND DIGITAL CONTENT, STORING E-BOOKS AND DIGITAL CONTENT, ORGANIZING E-BOOKS AND DIGITAL CONTENT, TRACKING, TESTING AND ANALYZING THE READER'S PROFICIENCY, COMPREHENSION AND VOCABULARY, PROJECTING FUTURE READING ABILITIES, CREATING LISTS OR LIBRARIES OF E-BOOKS, PROMOTING AND RECOMMENDING OTHER BOOKS OF INTEREST TO THE READER, ALLOWING THE USER TO RATE AND REVIEW THE E-BOOKS, SOCIAL NETWORKING, PROVIDING AN ONLINE STUDENT PORTFOLIO WITH STUDENT AND CLASS PROJECTS, PERSONALIZED LEARNING; SOFTWARE AS A SERVICE (SAAS) SERVICES, NAMELY, HOSTING SOFTWARE FOR USE BY OTHERS FOR USE IN READING E-BOOKS AND DIGITAL CONTENT, STORING E-BOOKS AND DIGITAL CONTENT, ORGANIZING E-BOOKS AND DIGITAL CONTENT, TRACKING, TESTING AND ANALYZING THE READER'S PROFICIENCY, COMPREHENSION AND VOCABULARY, PROJECTING FUTURE READING ABILITIES, CREATING LISTS OR LIBRARIES OF E-BOOKS, PROMOTING AND RECOMMENDING OTHER BOOKS OF INTEREST TO THE READER, ALLOWING THE USER TO RATE AND REVIEW THE E-BOOKS, SOCIAL NETWORKING, PROVIDING AN ONLINE STUDENT PORTFOLIO WITH STUDENT AND CLASS PROJECTS, PERSONALIZED LEARNING (U.S. CLS. 100 AND 101).

FIRST USE 11-1-2010; IN COMMERCE 11-1-2010.

4,016,974. INDUSTRIAS T.TAIO, LOS ANGELES, CA. SN 85-080,935. PUB. 12-14-2010, FILED 7-9-2010.

DAILY CONCEPTS

THE MARK CONSISTS OF STANDARD CHARACTERS WITHOUT CLAIM TO ANY PARTICULAR FONT, STYLE, SIZE, OR COLOR.

CLASS 3—COSMETICS AND CLEANING PREPARATIONS

FOR COSMETICS AND CLEANING PRODUCTS, NAMELY, BODY WASH; LOOFAH SOAPS; FACE AND BODY LOTIONS; BATH SOAPS FOR ALL CONSUMERS (U.S. CLS. 1, 4, 6, 50, 51 AND 52).

FIRST USE 4-1-2011; IN COMMERCE 4-1-2011.

CLASS 21—HOUSEWARES AND GLASS

FOR HOUSE WARE AND GLASS PRODUCTS, NAMELY, BATH PRODUCTS, NAMELY, LOOFAH SPONGES, BATH AND BODY SPONGES, AND BODY SCRUBBING SPONGES AND BRUSHES; SCOURING SPONGES; BEVERAGE GLASSWARE; KITCHEN SCRUBBING SPONGES AND BRUSHES; SPONGES FOR HOUSEHOLD PURPOSES FOR CONSUMERS (U.S. CLS. 2, 13, 23, 29, 30, 33, 40 AND 50).

FIRST USE 4-1-2011; IN COMMERCE 4-1-2011.

4,016,978. VILLAGE OF HOFFMAN ESTATES, HOFFMAN ESTATES, IL. SN 85-081,962. PUB. 12-14-2010, FILED 7-10-2010.



THE MARK CONSISTS OF THE NUMBERS "59" AND "90" ON A CIRCULAR BACKGROUND.

CLASS 35—ADVERTISING AND BUSINESS

FOR CHAMBER OF COMMERCE SERVICES, NAMELY, PROMOTING BUSINESS AND TOURISM IN THE HOFFMAN ESTATES, ILLINOIS AREA; COOPERATIVE ADVERTISING AND MARKETING; PROMOTING PUBLIC AWARENESS OF SHOPPING LOCALLY; PROMOTING RECREATION AND TOURISM IN HOFFMAN ESTATES, ILLINOIS; PROMOTING THE GOODS AND SERVICES OF OTHERS BY ARRANGING FOR SPONSORS TO AFFILIATE THEIR GOODS AND SERVICES WITH A MIXED-USE RETAIL, COMMERCIAL, OFFICE, SPORTS AND ENTERTAINMENT CENTER ENVIRONMENT (U.S. CLS. 100, 101 AND 102).

FIRST USE 8-0-2010; IN COMMERCE 8-0-2010.

CLASS 41—EDUCATION AND ENTERTAINMENT

FOR ENTERTAINMENT IN THE NATURE OF LIVE PERFORMANCES BY MUSICIANS IN A MIXED-USE RETAIL MALL AND ENTERTAINMENT CENTER ENVIRONMENT; ENTERTAINMENT IN THE NATURE OF THEATER PRODUCTIONS; ENTERTAINMENT IN THE NATURE OF BASEBALL, FOOTBALL, BASKETBALL, HOCKEY AND TENNIS GAMES (U.S. CLS. 100, 101 AND 107).

FIRST USE 8-8-2010; IN COMMERCE 8-8-2010.

4,016,985. VIDO VATION CORPORATION, ALISO VIEJO, CA. SN 85-082,718. PUB. 11-9-2010, FILED 7-12-2010.



NO CLAIM IS MADE TO THE EXCLUSIVE RIGHT TO USE "VIDEO", APART FROM THE MARK AS SHOWN.

THE COLOR(S) BLUE, LIGHT BLUE, DARK BLUE AND BLACK IS/ARE CLAIMED AS A FEATURE OF THE MARK.

THE MARK CONSISTS OF A STYLIZED LETTER "V" IN AS PART OF A RIBBON DESIGN SWIRLING INTO A VORTEX IN LIGHT BLUE AND DARK BLUE, ABOVE THE WORD "VIDOVATION" IN BLACK ABOVE THE WORDS "MOVING VIDEO FORWARD" IN BLUE.

CLASS 9—ELECTRICAL AND SCIENTIFIC APPARATUS

FOR AMPLIFIERS; APPARATUS FOR BROADCASTING, RECORDING, TRANSMISSION OR REPRODUCTION OF SOUND OR IMAGES; APPARATUS FOR TRANSMISSION OF COMMUNICATION; AUDIO-RECEIVERS AND VIDEO-RECEIVERS; AUDIO-VIDEO RECEIVERS; AUTOMATIC SWITCHING APPARATUS; BUILDING SECURITY SYSTEMS COMPRISING SOFTWARE AND HARDWARE FOR PROVIDING PICTURE, VIDEO, ALARM STATUS, AND OTHER INFORMATION TO A REMOTE STATION; COMPONENT VIDEO CABLES; COMPUTER HARDWARE AND COMPUTER PERIPHERAL DEVICES; COMPUTER HARDWARE AND PERIPHERAL DEVICES AND COMPUTER SOFTWARE FOR DATA COMMUNICATION AND TRANSLATING AND TRANSMITTING DATA SOLD THEREWITH; COMPUTER HARDWARE FOR COMMUNICATING AUDIO, VIDEO AND DATA BETWEEN COMPUTERS VIA A GLOBAL COMPUTER NETWORK, WIDE-AREA COMPUTER NETWORKS, AND PEER-TO-PEER COMPUTER NETWORKS; COMPUTER HARDWARE FOR IP VIDEO SURVEILLANCE; COMPUTER HARDWARE FOR TELECOMMUNICATIONS; COMPUTER HARDWARE FOR UPLOAD, STORAGE, RETRIEVAL, DOWNLOAD, TRANSMISSION AND DELIVERY OF DIGITAL CONTENT; DECODER SOFTWARE; DISTRIBUTION AMPLIFIERS FOR AUDIO AND VIDEO SIGNALS; ELECTRONIC AND OPTICAL COMMUNICATIONS INSTRUMENTS AND COMPONENTS, NAMELY, DIGITAL TRANSMITTERS; ELECTRONIC APPARATUS, NAMELY, ELECTRONIC DISPLAY SCREENS; ELECTRONIC APPARATUS, NAMELY, PLASMA DISPLAY PANELS; ELECTRONIC EQUIPMENT, NAMELY, TRANSFORMERS, BALUNS, CABLES USED IN CONNECTION WITH COMPUTERS, COMPUTER PERIPHERAL DEVICES, TELEVISIONS, AUDIO-VIDEO EQUIPMENT, CLOSED-CIRCUIT TV EQUIPMENT AND TELECOMMUNICATION EQUIPMENT; ELECTRONIC INTERCONNECTERS FOR AUDIO AND VIDEO SIGNALS; ELECTRONIC LCD DISPLAY UNIT WITH MULTI-NETWORKING (TCP/IP) CAPABILITIES; ELECTRONIC SCALERS FOR AUDIO AND VIDEO

SIGNALS; ELECTRONIC SWITCHERS FOR AUDIO AND VIDEO SIGNALS; ELECTRONIC TRANSMITTERS AND RECEIVERS FOR AUDIO AND VIDEO; ENCODERS; ENCODING AND DECODING APPARATUS; ENCODING AND DECODING APPARATUS AND INSTRUMENTS; INTEGRATED CIRCUITS, INTEGRATED CIRCUIT CHIPS, AND INTEGRATED CIRCUIT MODULES FOR ENCODING AND DECODING DIGITAL VIDEO; INTEROPERABLE COMMUNICATION SYSTEM DESIGNED TO PROVIDE RADIO, STREAMING VIDEO, WIRELESS INTERNET, AND VOIP PHONE; IP (INTERNET PROTOCOL) CAMERAS; IP VIDEO SERVERS; LCD LARGE-SCREEN DISPLAYS; LIQUID CRYSTAL DISPLAY (LCD) MONITORS; PLASMA TELEVISIONS; RECEIVERS FOR AUDIO AND VIDEO; TELECOMMUNICATIONS AND DATA NETWORKING HARDWARE, NAMELY, DEVICES FOR TRANSPORTING AND AGGREGATING VOICE, DATA, AND VIDEO COMMUNICATIONS ACROSS MULTIPLE NETWORK INFRASTRUCTURES AND COMMUNICATIONS PROTOCOLS; TELECOMMUNICATIONS TRANSMITTERS; TELEVISION DECODER; TELEVISION TRANSMITTERS; TRANSMITTERS AND RECEIVERS FOR AUDIO AND VIDEO SIGNALS FOR TRANSMISSION OVER TWISTED PAIR CABLES; VIDEO CABLES; VIDEO MONITORS; VIDEO MULTIPLEXERS; VIDEO PROCESSORS; VIDEO RECEIVERS; VIDEO SCREENS; VIDEO TRANSMISSION APPARATUS; WIRELESS TELEVISION SET FOR PROVIDING VIDEO CONFERENCING AND TELEPHONE SERVICE OVER THE INTERNET (U.S. CLS. 21, 23, 26, 36 AND 38).

FIRST USE 1-24-2011; IN COMMERCE 1-24-2011.

CLASS 38—COMMUNICATION

FOR AUDIO AND VIDEO BROADCASTING SERVICES OVER THE INTERNET; BROADCASTING OF VIDEO AND AUDIO PROGRAMMING OVER THE INTERNET; BROADCASTING PROGRAMS VIA A GLOBAL COMPUTER NETWORK; COMMUNICATION BY ELECTRONIC COMPUTER TERMINALS; COMMUNICATION SERVICES, NAMELY, TRANSMISSION OF VOICE, AUDIO, VISUAL IMAGES AND DATA BY TELECOMMUNICATIONS NETWORKS, WIRELESS COMMUNICATION NETWORKS, THE INTERNET, INFORMATION SERVICES NETWORKS AND DATA NETWORKS; COMMUNICATION VIA ANALOGUE AND DIGITAL COMPUTER TERMINALS; COMMUNICATION VIA COMPUTER TERMINALS, BY DIGITAL TRANSMISSION OR BY SATELLITE; COMMUNICATIONS BY COMPUTER TERMINALS; ELECTRONIC TRANSMISSION AND STREAMING OF DIGITAL MEDIA CONTENT FOR OTHERS VIA GLOBAL AND LOCAL COMPUTER NETWORKS; ELECTRONIC TRANSMISSION OF DATA AND DOCUMENTS VIA COMPUTER TERMINALS AND ELECTRONIC DEVICES; ELECTRONIC TRANSMISSION OF VOICE, DATA AND IMAGES BY TELEVISION AND VIDEO BROADCASTING; ELECTRONIC, ELECTRIC, AND DIGITAL TRANSMISSION OF VOICE, DATA, IMAGES, SIGNALS, AND MESSAGES; INFORMATION TRANSMISSION SERVICES VIA DIGITAL NETWORKS; INFORMATION TRANSMISSION VIA ELECTRONIC COMMUNICATIONS NETWORKS; INTERACTIVE DELIVERY OF VIDEO OVER DIGITAL NETWORKS; INTERNET BROADCASTING SERVICES; INTERNET PROTOCOL TELEVISION (IPTV) TRANSMISSION SERVICES; PEER-TO-PEER NETWORK COMPUTER SERVICES, NAMELY, ELECTRONIC TRANSMISSION OF AUDIO, VIDEO AND OTHER DATA AND DOCUMENTS AMONG COMPUTERS; PROVIDING CO-LOCATION SERVICES FOR VOICE, VIDEO AND DATA COMMUNICATIONS APPLICATIONS; PROVIDING FACILITIES AND EQUIPMENT FOR VIDEO CONFERENCING; PROVISION OF VIDEO CONFERENCING SERVICES; STREAMING OF VIDEO MATERIAL ON THE INTERNET; STREAMING OF AUDIO, VISUAL, AND AUDIOVISUAL MATERIAL ON THE INTERNET; TELECOMMUNICATION CONSULTATION IN THE NATURE OF TECHNICAL CONSULTING IN THE FIELD OF AUDIO, TEXT AND VISUAL DATA TRANSMISSION AND COMMUNICATION; TELECOMMUNICATION SERVICES, NAMELY, LOCAL AND LONG DISTANCE TRANSMISSION OF VOICE, DATA, GRAPHICS AND VIDEO BY MEANS OF BROADBAND OPTICAL OR WIRELESS NETWORKS; TELECOMMUNICATION SERVICES, NAMELY, LOCAL AND LONG DISTANCE TRANSMISSION OF VOICE, DATA, GRAPHICS AND VIDEO BY MEANS OF BROADBAND,

COPPER AND OPTICAL OR WIRELESS NETWORKS; TELECOMMUNICATION SERVICES, NAMELY, PROVIDING ACCESS TO PICTURES, VIDEO, ALARM STATUS AND OTHER BUILDING AND SECURITY INFORMATION AT A REMOTE STATION; TELECOMMUNICATION SERVICES, NAMELY, TRANSMISSION OF VOICE, DATA, GRAPHICS, IMAGES, AUDIO AND VIDEO BY MEANS OF TELECOMMUNICATIONS NETWORKS, WIRELESS COMMUNICATION NETWORKS, AND THE INTERNET; TELECOMMUNICATION SERVICES, NAMELY, TRANSMISSION OF VOICE, DATA, GRAPHICS, SOUND AND VIDEO BY MEANS OF BROADBAND POWER LINE OR WIRELESS NETWORKS; TELECONFERENCING AND VIDEO CONFERENCING SERVICES; TRANSMISSION AND DISTRIBUTION OF DATA OR AUDIO VISUAL IMAGES VIA A GLOBAL COMPUTER NETWORK OR THE INTERNET; TRANSMISSION OF INFORMATION BY ELECTRONIC COMMUNICATIONS NETWORKS; TRANSMISSION OF INFORMATION ON OPTICAL TELECOMMUNICATION NETWORKS; TRANSMISSION OF INFORMATION THROUGH VIDEO COMMUNICATION SYSTEMS; TRANSMISSION OF SDI-FORMATTED TELEVISION AND AUDIO SIGNALS OVER FIBER OPTIC CABLES; TRANSMISSION OF SOUND AND VISION VIA SATELLITE OR INTERACTIVE MULTIMEDIA NETWORKS; TRANSMISSION OF SOUND, VIDEO AND INFORMATION; TRANSMISSION OF SOUND, VIDEO AND INFORMATION FROM WEB CAMS, VIDEO CAMERAS OR MOBILE PHONES, ALL FEATURING LIVE OR RECORDED MATERIALS; VIDEO BROADCASTING; VIDEO BROADCASTING SERVICES OVER THE INTERNET OR OTHER COMMUNICATIONS NETWORK, NAMELY, ELECTRONICALLY TRANSMITTING VIDEO CLIPS; VIDEO CONFERENCING SERVICES; VIDEO NARROWCASTING SERVICES; VIDEO TELECONFERENCING; VIDEO TRANSMISSION OVER DIGITAL NETWORKS; VOICE OVER INTERNET PROTOCOL (VOIP) SERVICES; VOICE OVER IP SERVICES; WIRELESS ELECTRONIC TRANSMISSION OF VOICE SIGNALS, DATA, FACSIMILES, IMAGES AND INFORMATIONS (U.S. CLS. 100, 101 AND 104).

FIRST USE 5-6-2011; IN COMMERCE 5-6-2011.

CLASS 42—SCIENTIFIC AND COMPUTER SERVICES

FOR CONSULTING IN THE FIELD OF INFORMATION TECHNOLOGY; CONSULTING IN THE FIELD OF TELECOMMUNICATIONS TECHNOLOGY; CONSULTING SERVICES IN THE FIELD OF DESIGN, SELECTION, IMPLEMENTATION AND USE OF COMPUTER HARDWARE AND SOFTWARE SYSTEMS FOR OTHERS; DESIGN AND DEVELOPMENT OF SOFTWARE AND HARDWARE FOR AUDIO AND VIDEO OPERATORS; DESIGN AND DEVELOPMENT OF SOFTWARE AND HARDWARE FOR COMPRESSION AND DECOMPRESSION OF MULTIMEDIA CONTENTS; DESIGN AND DEVELOPMENT OF SOFTWARE AND HARDWARE FOR SIGNAL AMPLIFICATION AND TRANSMISSION; DESIGN AND DEVELOPMENT OF WIRELESS COMMUNICATION SYSTEMS FOR TRANSMISSION AND RECEPTION OF VOICE, DATA AND VIDEO; DIGITAL COMPRESSION OF AUDIO AND VIDEO FILES; PLANNING AND DEVELOPMENT OF ELECTRONIC COMMUNICATIONS NETWORKS; PLANNING, DESIGN AND MANAGEMENT OF INFORMATION TECHNOLOGY SYSTEMS; TECHNOLOGICAL CONSULTATION IN THE FIELD OF SELECTING APPARATUS FOR THE TRANSMISSION OF AUDIO AND VIDEO FILES SUITABLE FOR THEIR INTENDED USES; TECHNOLOGICAL CONSULTATION IN THE TECHNOLOGY FIELD OF TELECOMMUNICATIONS, CONDUCTIVITY AND/OR NETWORKING OF VIDEO AND AUDIO SIGNALS (U.S. CLS. 100 AND 101).

FIRST USE 3-7-2011; IN COMMERCE 3-7-2011.

4,016,986. FRITO-LAY NORTH AMERICA, INC., PLANO, TX. SN 85-082,758. PUB. 11-2-2010, FILED 7-12-2010.

ENJOY SOMETHING SIMPLE

THE MARK CONSISTS OF STANDARD CHARACTERS WITHOUT CLAIM TO ANY PARTICULAR FONT, STYLE, SIZE, OR COLOR.

CLASS 29—MEATS AND PROCESSED FOODS

FOR NUT-BASED SNACK FOODS; POTATO-BASED SNACK FOODS; PROCESSED EDIBLE SEEDS (U.S. CL. 46).
FIRST USE 7-0-2010; IN COMMERCE 7-0-2010.

CLASS 30—STAPLE FOODS

FOR CEREAL-BASED SNACK FOODS; CHEESE-FLAVORED CORN SNACKS; CORN-BASED SNACK FOODS; FLOUR-BASED CHIPS; MULTIGRAIN-BASED SNACK FOODS; PRETZELS; RICE-BASED SNACK FOODS; WHEAT-BASED SNACK FOODS (U.S. CL. 46).
FIRST USE 7-0-2010; IN COMMERCE 7-0-2010.

4,016,987. GALOOTGEAR, INC., VALENCIA, CA. SN 85-082,881. PUB. 12-7-2010, FILED 7-12-2010.

PULLMAN TACTICAL COLLEGE

THE MARK CONSISTS OF STANDARD CHARACTERS WITHOUT CLAIM TO ANY PARTICULAR FONT, STYLE, SIZE, OR COLOR.

CLASS 21—HOUSEWARES AND GLASS

FOR CUPS AND MUGS; PLASTIC WATER BOTTLES SOLD EMPTY (U.S. CLS. 2, 13, 23, 29, 30, 33, 40 AND 50).
FIRST USE 2-9-2011; IN COMMERCE 2-9-2011.

CLASS 25—CLOTHING

FOR BLOUSES; COATS; HATS; JACKETS; SHIRTS; SHOES; SHORTS; SOCKS; UNDERGARMENTS (U.S. CLS. 22 AND 39).
FIRST USE 2-9-2011; IN COMMERCE 2-9-2011.

4,016,989. GALOOTGEAR, INC., VALENCIA, CA. SN 85-082,887. PUB. 12-14-2010, FILED 7-12-2010.

GALACTIC UNIVERSITY

THE MARK CONSISTS OF STANDARD CHARACTERS

WITHOUT CLAIM TO ANY PARTICULAR FONT, STYLE, SIZE, OR COLOR.

CLASS 21—HOUSEWARES AND GLASS

FOR CUPS AND MUGS; PLASTIC WATER BOTTLES SOLD EMPTY (U.S. CLS. 2, 13, 23, 29, 30, 33, 40 AND 50).
FIRST USE 2-9-2011; IN COMMERCE 2-9-2011.

CLASS 25—CLOTHING

FOR BLOUSES; COATS; HATS; JACKETS; PANTS; SHIRTS; SHOES; SHORTS; SOCKS; UNDERGARMENTS (U.S. CLS. 22 AND 39).
FIRST USE 2-9-2011; IN COMMERCE 2-9-2011.

4,016,998. CARROLL, BIME L, JACKSON, MS. SN 85-086,044. PUB. 4-19-2011, FILED 7-15-2010.

MISSISSIPPI'S FINEST

THE MARK CONSISTS OF STANDARD CHARACTERS WITHOUT CLAIM TO ANY PARTICULAR FONT, STYLE, SIZE, OR COLOR.

NO CLAIM IS MADE TO THE EXCLUSIVE RIGHT TO USE "MISSISSIPPI'S", APART FROM THE MARK AS SHOWN.

CLASS 25—CLOTHING

FOR APPAREL FOR DANCERS, NAMELY, TEE SHIRTS, SWEATSHIRTS, PANTS, LEGGINGS, SHORTS AND JACKETS; ATHLETIC APPAREL, NAMELY, SHIRTS, PANTS, JACKETS, FOOTWEAR, HATS AND CAPS, ATHLETIC UNIFORMS; CHILDREN'S AND INFANT'S APPAREL, NAMELY, JUMPERS, OVERALL SLEEPWEAR, PAJAMAS, ROMPERS AND ONE-PIECE GARMENTS (U.S. CLS. 22 AND 39).
FIRST USE 10-31-2010; IN COMMERCE 10-31-2010.

CLASS 35—ADVERTISING AND BUSINESS

FOR ADVERTISEMENT FOR OTHERS ON THE INTERNET; ADVERTISING AGENCIES, NAMELY, PROMOTING THE GOODS AND SERVICES OF OTHERS; ADVERTISING AND DIRECTORY SERVICES, NAMELY, PROMOTING THE SERVICES OF OTHERS BY PROVIDING A WEB PAGE FEATURING LINKS TO THE WEBSITES OF OTHERS; CHARITABLE SERVICES, NAMELY, PROVIDING A FREE ONLINE RESOURCE IN THE NATURE OF A WEBSITE FOR CONNECTING PEOPLE WHO HAVE SERVICE NEEDS WITH PEOPLE WHO ARE WILLING TO PROVIDE VOLUNTEER SERVICES; PROVIDING A SEARCHABLE WEBSITE FEATURING THE GOODS AND SERVICES OF OTHER VENDORS; PROVIDING A WEBSITE WHERE OWNERS CAN POST ITEMS AND SERVICES AVAILABLE FOR RENT BY OTHERS; PROVIDING AN INTERNET WEBSITE FEATURING NEWS AND INFORMATION IN THE FIELD OF NATIONAL AND INTERNATIONAL POLITICS; PROVISION OF SPACE ON WEBSITES FOR ADVERTISING GOODS AND SERVICES (U.S. CLS. 100, 101 AND 102).

FIRST USE 10-31-2010; IN COMMERCE 10-31-2010.

4,017,002. VANI U.S.A., INC., NEW YORK, NY. SN 85-086,559. PUB. 11-30-2010, FILED 7-16-2010.

ANAIS GVANI NEW YORK

THE MARK CONSISTS OF STANDARD CHARACTERS WITHOUT CLAIM TO ANY PARTICULAR FONT, STYLE, SIZE, OR COLOR.

OWNER OF U.S. REG. NO. 3,694,079.

NO CLAIM IS MADE TO THE EXCLUSIVE RIGHT TO USE "NEW YORK", APART FROM THE MARK AS SHOWN.

THE NAME "ANAIS GVANI" DOES NOT IDENTIFY A LIVING INDIVIDUAL.

CLASS 18—LEATHER GOODS

FOR LEATHER AND IMITATIONS OF LEATHER ARTICLES, NAMELY, TRUNKS AND TRAVELING BAGS, BRIEF CASES, BACK PACKS, HAND BAGS, TOTE BAGS, SHOPPING BAGS, WALLETS, PURSES, KEY CASE AND KEY CHAINS (U.S. CLS. 1, 2, 3, 22 AND 41).

FIRST USE 3-18-2008; IN COMMERCE 3-18-2008.

CLASS 25—CLOTHING

FOR CLOTHING, NAMELY, HEADWEAR, FOOTWEAR, JACKETS, JEANS, DRESSES, SKIRTS, SUITS, SWEATERS, JERSEY, SHIRTS, BLOUSES, VESTS, SINGLET, TROUSERS, PANTS, SHORTS, DUNGAREES, SOCKS, LEGGINGS, SHAWLS, GLOVES, HATS, CAPS, HOODS, BONNETS, LEATHER AND IMITATION LEATHER HATS, AND BELTS AND TIES (U.S. CLS. 22 AND 39).

FIRST USE 3-18-2008; IN COMMERCE 3-18-2008.

4,017,008. CRAWFORD & COMPANY, ATLANTA, GA. SN 85-088,511. PUB. 10-26-2010, FILED 7-20-2010.

BROADSPIRE WORKS

THE MARK CONSISTS OF STANDARD CHARACTERS WITHOUT CLAIM TO ANY PARTICULAR FONT, STYLE, SIZE, OR COLOR.

OWNER OF U.S. REG. NOS. 3,245,843 AND 3,245,844.

CLASS 36—INSURANCE AND FINANCIAL

FOR CONSULTING SELF INSURED EMPLOYERS REGARDING THE EVALUATION AND ADMINISTRATION OF RETURN-TO-WORK PROGRAMS; INSURANCE CONSULTING AND PLANNING; INSURANCE CONSULTING REGARDING RETURN-TO-WORK PROGRAMS; CONDUCTING INSURANCE LOSS CONTROL ASSESSMENTS; PROVIDING INFORMATION IN INSURANCE MATTERS (U.S. CLS. 100, 101 AND 102).

FIRST USE 9-0-2010; IN COMMERCE 9-0-2010.

CLASS 41—EDUCATION AND ENTERTAINMENT

FOR ARRANGING AND CONDUCTING TRAINING WORKSHOPS IN CONNECTION WITH RETURN-TO-WORK PROGRAMS (U.S. CLS. 100, 101 AND 107).

FIRST USE 9-0-2010; IN COMMERCE 9-0-2010.

4,017,017. MCGRAW-HILL COMPANIES, INC., THE, NEW YORK, NY. SN 85-091,368. PUB. 11-9-2010, FILED 7-23-2010.

WORDS TO LEARN BY

THE MARK CONSISTS OF STANDARD CHARACTERS WITHOUT CLAIM TO ANY PARTICULAR FONT, STYLE, SIZE, OR COLOR.

CLASS 9—ELECTRICAL AND SCIENTIFIC APPARATUS

FOR COMPUTER SOFTWARE DOWNLOADABLE TO A HAND-HELD DEVICE CONTAINING VOCABULARY INSTRUCTION FOR ADULTS (U.S. CLS. 21, 23, 26, 36 AND 38).

FIRST USE 4-12-2011; IN COMMERCE 4-12-2011.

CLASS 16—PAPER GOODS AND PRINTED MATTER

FOR SERIES OF TEXTBOOKS ON THE SUBJECT OF VOCABULARY INSTRUCTION FOR ADULTS (U.S. CLS. 2, 5, 22, 23, 29, 37, 38 AND 50).

FIRST USE 12-10-2010; IN COMMERCE 12-10-2010.

4,017,020. VIVEVITA, LLC, CHARLOTTE, NC. SN 85-092,791. PUB. 1-4-2011, FILED 7-26-2010.

EVERYDAY ELEGANCE

THE MARK CONSISTS OF STANDARD CHARACTERS WITHOUT CLAIM TO ANY PARTICULAR FONT, STYLE, SIZE, OR COLOR.

CLASS 20—FURNITURE AND ARTICLES NOT OTHERWISE CLASSIFIED

FOR FITTED FABRIC FURNITURE COVERS, NAMELY, REVERSIBLE CHAIR SEAT COVERS MADE OF WATER-RESISTANT AND STAIN-RESISTANT FABRICS; FITTED FURNITURE COVERS NOT OF FABRIC, NAMELY, CHAIR SEAT COVERS HAVING A WATER-RESISTANT BACKING (U.S. CLS. 2, 13, 22, 25, 32 AND 50).

FIRST USE 10-15-2010; IN COMMERCE 10-15-2010.

CLASS 24—FABRICS

FOR UNFITTED CHAIR SEAT COVERS MADE OF TEXTILES (U.S. CLS. 42 AND 50).
FIRST USE 10-15-2010; IN COMMERCE 10-15-2010.

4,017,036. GALOOTGEAR, INC., VALENCIA, CA. SN 85-099,742. PUB. 12-7-2010, FILED 8-4-2010.

GALOOTGEAR

THE MARK CONSISTS OF STANDARD CHARACTERS WITHOUT CLAIM TO ANY PARTICULAR FONT, STYLE, SIZE, OR COLOR.

CLASS 21—HOUSEWARES AND GLASS

FOR BOTTLES, SOLD EMPTY; CUPS AND MUGS (U.S. CLS. 2, 13, 23, 29, 30, 33, 40 AND 50).
FIRST USE 1-9-2011; IN COMMERCE 1-9-2011.

CLASS 25—CLOTHING

FOR BLOUSES; COATS; HATS; JACKETS; PANTS; SHIRTS; SHOES; SHORTS; SOCKS; UNDERGARMENTS (U.S. CLS. 22 AND 39).
FIRST USE 1-9-2011; IN COMMERCE 1-9-2011.

FLECK

THE MARK CONSISTS OF STANDARD CHARACTERS WITHOUT CLAIM TO ANY PARTICULAR FONT, STYLE, SIZE, OR COLOR.

CLASS 9—ELECTRICAL AND SCIENTIFIC APPARATUS

FOR SOFTWARE FOR PROVIDING MULTI-USER ACCESS TO AN ONLINE VIRTUAL ENVIRONMENT; COMPUTER VIRTUAL ENVIRONMENT SOFTWARE, NAMELY, SOFTWARE FOR USE IN CREATING, MANIPULATING, PARTICIPATING IN VIRTUAL ENVIRONMENTS THAT ACCESS AND MESH WITH WEB SITES AND DATA BASES, LIVE DIRECT OR INDIRECT VIEW OF PHYSICAL REAL-WORLD ENVIRONMENTS WHOSE ELEMENTS ARE AUGMENTED BY VIRTUAL COMPUTER-GENERATED IMAGERY, AND FACILITATE ENGAGING IN SOCIAL NETWORKING (U.S. CLS. 21, 23, 26, 36 AND 38).
FIRST USE 6-30-2010; IN COMMERCE 6-30-2010.

4,017,038. SUYEN CORPORATION, PASAY CITY, 1300, PHILIPPINES. SN 85-099,875. PUB. 10-26-2010, FILED 8-4-2010.

PINOYLAB

THE MARK CONSISTS OF STANDARD CHARACTERS WITHOUT CLAIM TO ANY PARTICULAR FONT, STYLE, SIZE, OR COLOR.

CLASS 41—EDUCATION AND ENTERTAINMENT

FOR ENTERTAINMENT SERVICES, NAMELY, PROVIDING VIRTUAL ENVIRONMENTS IN WHICH USERS CAN INTERACT FOR RECREATIONAL, LEISURE OR ENTERTAINMENT PURPOSES (U.S. CLS. 100, 101 AND 107).
FIRST USE 6-30-2010; IN COMMERCE 6-30-2010.

CLASS 3—COSMETICS AND CLEANING PREPARATIONS

FOR ESSENTIAL OILS; PERFUMERIES (U.S. CLS. 1, 4, 6, 50, 51 AND 52).
FIRST USE 2-25-2011; IN COMMERCE 6-3-2011.

CLASS 42—SCIENTIFIC AND COMPUTER SERVICES

FOR COMPUTER SERVICES, NAMELY, HOSTING AN ON-LINE VIRTUAL ENVIRONMENT FEATURING A WIDE VARIETY OF USER-DEFINED SUBJECT MATTER AND HOSTING AN ON-LINE VIRTUAL ENVIRONMENT FEATURING A WIDE VARIETY OF USER-DEFINED SUBJECT MATTER THAT MAY BE ACCESSED BY MEANS OF COMMUNICATIONS NETWORKS; COMPUTER SERVICES, NAMELY, CREATING AN ON-LINE COMMUNITY FOR USERS TO PARTICIPATE IN DISCUSSIONS, GET FEEDBACK FROM THEIR PEERS, FORM VIRTUAL COMMUNITIES, AND ENGAGE IN SOCIAL NETWORKING (U.S. CLS. 100 AND 101).
FIRST USE 6-30-2010; IN COMMERCE 6-30-2010.

CLASS 6—METAL GOODS

FOR METAL KEY HOLDERS; METAL RINGS AND CHAINS FOR KEYS (U.S. CLS. 2, 12, 13, 14, 23, 25 AND 50).
FIRST USE 9-10-2009; IN COMMERCE 6-3-2011.

CLASS 16—PAPER GOODS AND PRINTED MATTER

FOR ADVERTISING SIGNS OF PAPER OR CARDBOARD; PAPER BAGS AND SACKS; PASSPORT HOLDERS (U.S. CLS. 2, 5, 22, 23, 29, 37, 38 AND 50).
FIRST USE 7-25-2003; IN COMMERCE 6-3-2011.

CLASS 18—LEATHER GOODS

FOR ALL-PURPOSE CARRYING BAGS; MESSENGER BAGS; POUCHES FOR HOLDING MAKE-UP, KEYS AND OTHER PERSONAL ITEMS; POUCHES MADE FROM IMITATION LEATHER; POUCHES MADE OUT OF CLOTH; TOTE BAGS; WALLETS; WALLETS MADE OF LEATHER OR OTHER MATERIALS (U.S. CLS. 1, 2, 3, 22 AND 41).

FIRST USE 9-10-2009; IN COMMERCE 6-3-2011.

CLASS 20—FURNITURE AND ARTICLES NOT OTHERWISE CLASSIFIED

FOR NON-METAL AND NON-LEATHER KEY CHAINS (U.S. CLS. 2, 13, 22, 25, 32 AND 50).

FIRST USE 7-25-2003; IN COMMERCE 6-3-2011.

CLASS 25—CLOTHING

FOR T-SHIRTS; TOPS; UNDERSHIRTS; BANDANAS; BELTS; BELTS MADE FROM IMITATION LEATHER; BELTS MADE OUT OF CLOTH; BLOUSES; BRAS; BRIEFS; CAPS; CARDIGANS; DRESSES; FOOTWEAR; LINGERIE; PANTIES; POLO SHIRTS; SANDALS; SCARVES; SHORTS; SLIPPERS; SOCKS; SWEAT SHIRTS; SWEATERS; UNDERWEAR; VESTS (U.S. CLS. 22 AND 39).

FIRST USE 7-25-2003; IN COMMERCE 6-3-2011.

CLASS 26—FANCY GOODS

FOR NOVELTY BUTTONS (U.S. CLS. 37, 39, 40, 42 AND 50).

FIRST USE 10-1-2009; IN COMMERCE 6-3-2011.

CLASS 35—ADVERTISING AND BUSINESS

FOR ON-LINE RETAIL STORE SERVICES FEATURING CLOTHING; RETAIL CLOTHING STORES (U.S. CLS. 100, 101 AND 102).

FIRST USE 9-10-2009; IN COMMERCE 6-3-2011.

4,017,042. DEPARTMENT OF DEFENSE, WASHINGTON, DC. SN 85-101,111. PUB. 11-16-2010, FILED 8-5-2010.

FIGURE OUT WHAT'S NEXT

THE MARK CONSISTS OF STANDARD CHARACTERS WITHOUT CLAIM TO ANY PARTICULAR FONT, STYLE, SIZE, OR COLOR.

CLASS 35—ADVERTISING AND BUSINESS

FOR PROVIDING CAREER INFORMATION TO YOUNG ADULTS; PROVIDING INFORMATION TO YOUNG ADULTS ABOUT MILITARY SERVICE OPPORTUNITIES (U.S. CLS. 100, 101 AND 102).

FIRST USE 8-10-2010; IN COMMERCE 8-10-2010.

CLASS 41—EDUCATION AND ENTERTAINMENT

FOR PROVIDING INFORMATION TO YOUNG ADULTS ABOUT COLLEGE EDUCATION OPTIONS; PROVIDING INFORMATION TO YOUNG ADULTS ABOUT SELECTING COLLEGES AND UNIVERSITIES (U.S. CLS. 100, 101 AND 107).

FIRST USE 8-10-2010; IN COMMERCE 8-10-2010.

4,017,043. CHRIST CENTERED HOMES, INC., ATLANTA, TX. SN 85-101,496. PUB. 1-18-2011, FILED 8-5-2010.

CC CHAMPIONS

THE MARK CONSISTS OF STANDARD CHARACTERS WITHOUT CLAIM TO ANY PARTICULAR FONT, STYLE, SIZE, OR COLOR.

CLASS 35—ADVERTISING AND BUSINESS

FOR COORDINATION OF RECREATIONAL SPORTING OPPORTUNITIES FOR INDIVIDUALS WHO WISH TO PARTICIPATE IN TEAM LEAGUE SPORTS (U.S. CLS. 100, 101 AND 102).

FIRST USE 6-12-2011; IN COMMERCE 6-12-2011.

CLASS 45—PERSONAL AND LEGAL SERVICES

FOR MINISTERIAL SERVICES (U.S. CLS. 100 AND 101).

FIRST USE 6-12-2011; IN COMMERCE 6-12-2011.

4,017,046. SPORTSGRANTS, INC., HOOD RIVER, OR. SN 85-102,443. PUB. 1-25-2011, FILED 8-6-2010.

FIGHT GONE BAD

THE MARK CONSISTS OF STANDARD CHARACTERS WITHOUT CLAIM TO ANY PARTICULAR FONT, STYLE, SIZE, OR COLOR.

CLASS 35—ADVERTISING AND BUSINESS

FOR CHARITABLE SERVICES, NAMELY, ORGANIZING AND CONDUCTING CHARITABLE ATHLETIC EVENTS THAT PROMOTE PUBLIC AWARENESS OF THE IMPORTANCE OF FUNDRAISING FOR CHARITIES (U.S. CLS. 100, 101 AND 102).

FIRST USE 5-31-2006; IN COMMERCE 7-1-2006.

CLASS 36—INSURANCE AND FINANCIAL

FOR CHARITABLE FUNDRAISING SERVICES, NAMELY, ORGANIZING AND CONDUCTING ATHLETIC FUNDRAISING EVENTS FOR CHARITIES (U.S. CLS. 100, 101 AND 102).

FIRST USE 5-31-2006; IN COMMERCE 7-1-2006.

4,017,049. TEXAS BIOMEDICAL RESEARCH INSTITUTE, SAN ANTONIO, TX. SN 85-103,833. PUB. 3-29-2011, FILED 8-10-2010.

4,017,050. TEXAS BIOMEDICAL RESEARCH INSTITUTE, SAN ANTONIO, TX. SN 85-103,878. PUB. 4-12-2011, FILED 8-10-2010.



**TEXAS BIOMEDICAL
RESEARCH INSTITUTE**



NO CLAIM IS MADE TO THE EXCLUSIVE RIGHT TO USE "TEXAS BIOMEDICAL RESEARCH INSTITUTE", APART FROM THE MARK AS SHOWN.

THE MARK CONSISTS OF THE WORDING "TEXAS BIOMEDICAL RESEARCH INSTITUTE" ADJACENT A HELIX DESIGN.

CLASS 35—ADVERTISING AND BUSINESS

FOR ARRANGING AND CONDUCTING SALES FOR OTHERS OF LABORATORY ANIMALS (U.S. CLS. 100, 101 AND 102).

FIRST USE 2-1-2011; IN COMMERCE 2-1-2011.

CLASS 42—SCIENTIFIC AND COMPUTER SERVICES

FOR BIOMEDICAL RESEARCH; RESEARCH, EXPERIMENTATION AND TESTING IN THE FIELDS OF BIOLOGY AND CHEMISTRY; GENETICS AND VIROLOGY RESEARCH; RESEARCH IN THE FIELDS OF MEDICINE AND PHARMACEUTICALS; PROVIDING SCIENTIFIC CONSULTATION, PRODUCT DEVELOPMENT, AND LABORATORY RESEARCH IN THE FIELDS OF BIOLOGY, CHEMISTRY, GENETICS, VIROLOGY, MEDICINE, AND PHARMACEUTICALS; SCIENTIFIC RESEARCH IN THE FIELD OF ANIMAL HUSBANDRY OF PRIMATES (U.S. CLS. 100 AND 101).

FIRST USE 2-1-2011; IN COMMERCE 2-1-2011.

CLASS 43—HOTEL AND RESTAURANT SERVICES

FOR MANAGEMENT OF LABORATORY ANIMALS, NAMELY, BOARDING FOR ANIMALS (U.S. CLS. 100 AND 101).

FIRST USE 2-1-2011; IN COMMERCE 2-1-2011.

CLASS 44—MEDICAL, BEAUTY AND AGRICULTURAL SERVICES

FOR GENETIC TESTING OF ANIMALS; PROVIDING INFORMATION IN THE FIELD OF ANIMAL HUSBANDRY (U.S. CLS. 100 AND 101).

FIRST USE 2-1-2011; IN COMMERCE 2-1-2011.

THE MARK CONSISTS OF A PARTIAL HELIX.

CLASS 35—ADVERTISING AND BUSINESS

FOR ARRANGING AND CONDUCTING SALES FOR OTHERS OF LABORATORY ANIMALS (U.S. CLS. 100, 101 AND 102).

FIRST USE 2-1-2011; IN COMMERCE 2-1-2011.

CLASS 42—SCIENTIFIC AND COMPUTER SERVICES

FOR BIOMEDICAL RESEARCH; RESEARCH, EXPERIMENTATION AND TESTING IN THE FIELDS OF BIOLOGY AND CHEMISTRY; GENETICS AND VIROLOGY RESEARCH; RESEARCH IN THE FIELDS OF MEDICINE AND PHARMACEUTICALS; PROVIDING SCIENTIFIC CONSULTATION, PRODUCT DEVELOPMENT, AND LABORATORY RESEARCH IN THE FIELDS OF BIOLOGY, CHEMISTRY, GENETICS, VIROLOGY, MEDICINE, AND PHARMACEUTICALS; SCIENTIFIC RESEARCH IN THE FIELD OF ANIMAL HUSBANDRY OF PRIMATES (U.S. CLS. 100 AND 101).

FIRST USE 2-1-2011; IN COMMERCE 2-1-2011.

CLASS 43—HOTEL AND RESTAURANT SERVICES

FOR MANAGEMENT OF LABORATORY ANIMALS, NAMELY, BOARDING FOR ANIMALS (U.S. CLS. 100 AND 101).

FIRST USE 2-1-2011; IN COMMERCE 2-1-2011.

CLASS 44—MEDICAL, BEAUTY AND AGRICULTURAL SERVICES

FOR GENETIC TESTING OF ANIMALS; PROVIDING INFORMATION IN THE FIELD OF ANIMAL HUSBANDRY (U.S. CLS. 100 AND 101).

FIRST USE 2-1-2011; IN COMMERCE 2-1-2011.

4,017,053. NADHARI S. A. DE C.V., MÉXICO D.F., MEXICO.
SN 85-104,775. PUB. 1-25-2011, FILED 8-11-2010.



THE COLOR(S) ORANGE, FUCSIA AND PURPLE IS/ARE CLAIMED AS A FEATURE OF THE MARK.

THE MARK CONSISTS OF AN INCOMPLETE ORANGE CIRCLE WITH A FUCSIA LINE ACROSS IT, AND UNDER THIS FIGURE ARE THE LETTERS "QIUBO" IN PURPLE.

CLASS 9—ELECTRICAL AND SCIENTIFIC APPARATUS

FOR ELECTRONIC EQUIPMENT, NAMELY, TRANSFORMERS, BALUNS, CABLES USED IN CONNECTION WITH COMPUTERS, COMPUTER PERIPHERAL DEVICES, TELEVISIONS, AUDIO-VIDEO EQUIPMENT, CLOSED-CIRCUIT TV EQUIPMENT AND TELECOMMUNICATION EQUIPMENT; POINT-OF-SALE TERMINALS; TELEPHONE APPARATUS (U.S. CLS. 21, 23, 26, 36 AND 38).

FIRST USE 2-1-2011; IN COMMERCE 2-1-2011.

CLASS 36—INSURANCE AND FINANCIAL

FOR ELECTRONIC COMMERCE PAYMENT SERVICES, NAMELY, ESTABLISHING FUNDED ACCOUNTS USED TO PURCHASE GOODS AND SERVICES ON THE INTERNET; ELECTRONIC FOREIGN EXCHANGE PAYMENT PROCESSING; INSURANCE CARRIER SERVICES; INSURANCE SERVICES, NAMELY, INSURANCE ELIGIBILITY REVIEW AND VERIFICATION AND CONSULTATION IN THE LIFE, HEALTH, ACCIDENT, PROPERTY, FUNERAL COSTS AND REPATRIATION INDUSTRY; INSURANCE SERVICES, NAMELY, UNDERWRITING LIFE, HEALTH, ACCIDENT, PROPERTY, FUNERAL COSTS AND REPATRIATION INSURANCE; INSURANCE UNDERWRITING SERVICES FOR ALL TYPES OF INSURANCE; MEDICAL INSURANCE CASE AND UTILIZATION REVIEW AND INSURANCE CLAIMS ADJUSTMENT SERVICES FOR HEALTHCARE PURCHASERS AND PAYORS AND PROVIDERS AND MEDICARE BENEFICIARIES; ON-LINE FINANCIAL PLANNING SERVICES; PROCESSING ELECTRONIC PAYMENTS MADE THROUGH PREPAID CARDS; PROVIDING MULTIPLE PAYMENT OPTIONS BY MEANS OF CUSTOMER-OPERATED ELECTRONIC TERMINALS AVAILABLE ON-SITE IN RETAIL STORES; STRATEGIC CORPORATE FINANCIAL ADVISORY SERVICES; STRATEGIC FINANCIAL ADVISORY SERVICES; UNDERWRITING INSURANCE FOR PRE-PAID LEGAL SERVICES (U.S. CLS. 100, 101 AND 102).

FIRST USE 2-1-2011; IN COMMERCE 2-1-2011.

CLASS 38—COMMUNICATION

FOR DIGITAL NETWORK TELECOMMUNICATIONS SERVICES; INTERNET BASED PAGING AND ALERTING SERVICES, NAMELY, PROVIDING A WEB SITE AT WHICH USERS CAN SEND MESSAGES TO ELECTRONIC PAGING DEVICES; PROVIDING A WEB SITE THAT ENABLES COMMUNICATION SYNCHRONOUSLY AND ASYNCHRONOUSLY AND CONNECTION OF PHYSICIANS WITH THEIR PATIENTS REGARDLESS OF MEDICAL ORGANIZATION OR GEOGRAPHIC LOCATION; PROVIDING ON-LINE COMMUNICATIONS LINKS WHICH TRANSFER THE WEB SITE USER TO OTHER LOCAL AND GLOBAL WEB PAGES; TELECOMMUNICATION ACCESS SERVICES; TELECOMMUNICATIONS SERVICES, NAMELY, WIRELESS TELEPHONY AND WIRELESS BROADBAND COMMUNICATIONS SERVICES FOR THE TRANSMISSION OF VOICE AND DATA; WEB SITE FORWARDING SERVICES (U.S. CLS. 100, 101 AND 104).

FIRST USE 2-1-2011; IN COMMERCE 2-1-2011.

4,017,067. DIAMOND WIPES INTERNATIONAL, CHINO, CA. SN 85-108,322. PUB. 5-10-2011, FILED 8-16-2010.



THE COLOR(S) BLUE AND ORANGE IS/ARE CLAIMED AS A FEATURE OF THE MARK.

THE MARK CONSISTS OF STYLIZED WORDING "HANDYBATH" IN BLUE, AND A DROP DESIGN IN ORANGE.

CLASS 3—COSMETICS AND CLEANING PREPARATIONS

FOR AROMATIC BODY CARE PRODUCTS, NAMELY, BODY LOTION, SHOWER GEL, CUTICLE CREAM, SHAMPOO, CONDITIONER, NON-MEDICATED LIP BALM, SOAP, BODY POLISH, BODY AND FOOT SCRUB AND NON-MEDICATED FOOT CREAM; BABY WIPES; DISPOSABLE WIPES IMPREGNATED WITH CLEANSING CHEMICALS OR COMPOUNDS FOR PERSONAL HYGIENE, MAKEUP REMOVAL, PERSONAL DEODORIZING, SKIN MOISTURIZING, SUNSCREEN, HAND SANITIZING, PERSONAL LENS AND SCREEN CLEANING, SHOE POLISHING, SHAVING, HAIR STYLING, AND NAIL POLISH REMOVAL; PRE-MOISTENED COSMETIC WIPES (U.S. CLS. 1, 4, 6, 50, 51 AND 52).

FIRST USE 3-24-2010; IN COMMERCE 3-24-2010.

CLASS 5—PHARMACEUTICALS

FOR DISPOSABLE WIPES IMPREGNATED WITH DISINFECTING CHEMICALS OR COMPOUNDS THEREFOR FOR USE ON HOSPITALS, HOSPICES, NURSERIES, DAY CARE CENTERS, AND AT HOME AS A PART OF DAILY PERSONAL CLEANSING (U.S. CLS. 6, 18, 44, 46, 51 AND 52).

FIRST USE 3-24-2010; IN COMMERCE 3-24-2010.

4,017,074. SMALLEY, JEFF, NORTH HAVEN, CT. SN 85-110,221. PUB. 2-1-2011, FILED 8-18-2010.

PUNCH IN THE NOSE

THE MARK CONSISTS OF STANDARD CHARACTERS WITHOUT CLAIM TO ANY PARTICULAR FONT, STYLE, SIZE, OR COLOR.

CLASS 30—STAPLE FOODS

FOR HOT SAUCE (U.S. CL. 46).
FIRST USE 1-1-2011; IN COMMERCE 1-1-2011.

CLASS 33—WINES AND SPIRITS

FOR WINE (U.S. CLS. 47 AND 49).
FIRST USE 1-1-2011; IN COMMERCE 1-1-2011.

4,017,096. RONALD L. WOOLLEY, PROVO, UT. SN 85-119,037. PUB. 2-22-2011, FILED 8-30-2010.

BIPPY'S

THE MARK CONSISTS OF STANDARD CHARACTERS WITHOUT CLAIM TO ANY PARTICULAR FONT, STYLE, SIZE, OR COLOR.

CLASS 30—STAPLE FOODS

FOR FROZEN YOGURT; FROZEN YOGURT CONFECTIONS (U.S. CL. 46).
FIRST USE 1-1-2011; IN COMMERCE 1-1-2011.

CLASS 43—HOTEL AND RESTAURANT SERVICES

FOR FROZEN YOGURT SHOP SERVICES IN THE NATURE OF A RESTAURANT (U.S. CLS. 100 AND 101).
FIRST USE 1-1-2011; IN COMMERCE 1-1-2011.

4,017,101. CAPITAL ONE FINANCIAL CORPORATION, RICHMOND, VA. SN 85-122,244. PUB. 2-1-2011, FILED 9-2-2010.

JOURNEY

THE MARK CONSISTS OF STANDARD CHARACTERS WITHOUT CLAIM TO ANY PARTICULAR FONT, STYLE, SIZE, OR COLOR.

CLASS 35—ADVERTISING AND BUSINESS

FOR PROMOTING THE SALE OF CREDIT CARD ACCOUNTS THROUGH THE ADMINISTRATION OF INCENTIVE AWARD PROGRAMS (U.S. CLS. 100, 101 AND 102).

FIRST USE 12-1-2010; IN COMMERCE 12-1-2010.

CLASS 36—INSURANCE AND FINANCIAL

FOR FINANCIAL SERVICES, NAMELY, CREDIT CARD ACCOUNT SERVICES (U.S. CLS. 100, 101 AND 102).

FIRST USE 12-1-2010; IN COMMERCE 12-1-2010.

4,017,105. KERN RIVER CORPORATION, KERNVILLE, CA. SN 85-124,009. PUB. 3-15-2011, FILED 9-7-2010.



NO CLAIM IS MADE TO THE EXCLUSIVE RIGHT TO USE "WATERSPORTS", APART FROM THE MARK AS SHOWN.

THE MARK CONSISTS OF A STYLIZED LETTER "H" AND THE WORDS "HARDCORE WATER SPORTS".

CLASS 9—ELECTRICAL AND SCIENTIFIC APPARATUS

FOR LIFE JACKETS ; LIFE PRESERVERS ; LIFE VESTS ; LIFESAVING VESTS FOR USE BY DOGS ; SPORTS EQUIPMENT FOR KAYAKING AND WATERSPORTS, NAMELY, PROTECTIVE HEADGEAR (U.S. CLS. 21, 23, 26, 36 AND 38).

FIRST USE 11-1-2010; IN COMMERCE 11-1-2010.

CLASS 25—CLOTHING

FOR CLOTHING, NAMELY, SHIRTS, PANTS, SHOES, HATS, AND JACKETS, WATER SOCKS, WET SUITS, WET SUITS FOR WATER-SKIING, WATERPROOF JACKETS AND PANTS, SWIM WEAR, SWIM TRUNKS, SURFWEAR, SANDALS, FISHING VESTS, BOAT SHOES, BEACH FOOTWEAR, AND AQUA SHOES (U.S. CLS. 22 AND 39).

FIRST USE 11-1-2010; IN COMMERCE 11-1-2010.

4,017,120. ICON EYEWEAR, INC., SECAUCUS, NJ. SN 85-130,090. PUB. 3-8-2011, FILED 9-15-2010.

4,017,133. CORE 61, INC., ROUND ROCK, TX. SN 85-135,375. PUB. 4-12-2011, FILED 9-22-2010.

KOOL KRITTERS

THE MARK CONSISTS OF STANDARD CHARACTERS WITHOUT CLAIM TO ANY PARTICULAR FONT, STYLE, SIZE, OR COLOR.

CLASS 9—ELECTRICAL AND SCIENTIFIC APPARATUS

FOR SUNGLASSES (U.S. CLS. 21, 23, 26, 36 AND 38). FIRST USE 3-1-2011; IN COMMERCE 3-1-2011.

CLASS 28—TOYS AND SPORTING GOODS

FOR PLUSH TOYS (U.S. CLS. 22, 23, 38 AND 50). FIRST USE 3-1-2011; IN COMMERCE 3-1-2011.

4,017,128. CARDINAL CG COMPANY, EDEN PRAIRIE, MN. SN 85-133,780. PUB. 3-15-2011, FILED 9-20-2010.

LoĒ -180

THE MARK CONSISTS OF STANDARD CHARACTERS WITHOUT CLAIM TO ANY PARTICULAR FONT, STYLE, SIZE, OR COLOR.

OWNER OF U.S. REG. NOS. 1,611,760, 3,609,327, AND OTHERS.

CLASS 2—PAINTS

FOR COATINGS OF METALS APPLIED TO GLASS FOR USE IN THE FURTHER MANUFACTURE OF WINDOWS (U.S. CLS. 6, 11 AND 16). FIRST USE 1-0-2011; IN COMMERCE 1-0-2011.

CLASS 17—RUBBER GOODS

FOR COATINGS OF INSULATIVE DIELECTRIC COMPOUNDS APPLIED TO GLASS FOR USE IN THE FURTHER MANUFACTURE OF WINDOWS (U.S. CLS. 1, 5, 12, 13, 35 AND 50). FIRST USE 1-0-2011; IN COMMERCE 1-0-2011.



THE MARK CONSISTS OF THE WORDING "CORE 61" WITH A MOON OR PLANET ORBITING THE WORDING IN AN OVAL HALO DESIGN.

CLASS 10—MEDICAL APPARATUS

FOR MEDICAL APPAREL, NAMELY, SCRUB TOPS AND BOTTOMS, SCRUB JACKETS, PATIENT AND SURGICAL GOWNS, GLOVES, HEADWEAR, NAMELY, PROTECTIVE HEAD COVERINGS, SOCKS, SHOE COVERS, UNDERWEAR AND FOOTWEAR (U.S. CLS. 26, 39 AND 44).

FIRST USE 1-1-2011; IN COMMERCE 3-1-2011.

CLASS 25—CLOTHING

FOR CLOTHING, NAMELY, T-SHIRTS, GOLF SHIRTS, COMPRESSION SHIRTS, WORK SHIRTS AND PANTS, WORK JACKETS, WARM UP TOPS AND BOTTOMS, NON-MEDICAL SCRUB TOPS AND BOTTOMS, LAB COATS, NECK TIES, SCARVES, ATHLETIC UNIFORMS, CHEER UNIFORMS, SKIRTS, DRESSES, SHORTS, SKORTS, DANCE PANTS, TIGHTS, LEOTARDS, GLOVES, HEADWEAR, SOCKS, UNDERWEAR AND FOOTWEAR (U.S. CLS. 22 AND 39).

FIRST USE 1-1-2011; IN COMMERCE 3-1-2011.

4,017,140. KAY, COLLIN, SHERMAN OAKS, CA. AND BARNETT, NATHAN, SHERMAN OAKS, CA. SN 85-140,481. PUB. 4-19-2011, FILED 9-28-2010.

Danari Media

THE MARK CONSISTS OF STANDARD CHARACTERS WITHOUT CLAIM TO ANY PARTICULAR FONT, STYLE, SIZE, OR COLOR.

NO CLAIM IS MADE TO THE EXCLUSIVE RIGHT TO USE "MEDIA", APART FROM THE MARK AS SHOWN.

CLASS 35—ADVERTISING AND BUSINESS

FOR ADVERTISING, PROMOTION, AND MARKETING SERVICES IN THE NATURE OF MEDIA PLANNING, DELIVERY, AND MEDIA BUYING FOR OTHERS, NAMELY, DISSEMINATION OF ADVERTISING VIA COMPUTER NETWORKS, AND MOBILE DEVICES; MANAGING, TRACKING AND EVALUATING ADVERTISING AND MEDIA PLANNING FOR ADVERTISING PURPOSES, BUYING OF MEDIA TIME FOR ADVERTISING PURPOSES, AND THE SUCCESS OF ADVERTISING EFFORTS; MARKETING SERVICES, NAMELY, CONDUCTING MARKETING RESEARCH AND ANALYSIS; AND PROVIDING CONSULTING SERVICES IN THE FIELD OF ADVERTISING FOR MULTI-MEDIA USERS (U.S. CLS. 100, 101 AND 102).
FIRST USE 2-1-2011; IN COMMERCE 2-1-2011.

CLASS 42—SCIENTIFIC AND COMPUTER SERVICES

FOR PROVIDING TEMPORARY USE OF ON-LINE NONDOWNLOADABLE SOFTWARE AND APPLICATIONS FOR MANAGING, TRACKING AND EVALUATING ALL FORMS OF MEDIA AND ADVERTISING PLANNING, BUYING AND THE SUCCESS OF MEDIA, ADVERTISING AND MARKETING EFFORTS OF OTHERS VIA COMPUTER NETWORKS, MOBILE DEVICES, AND OTHER DEVICES (U.S. CLS. 100 AND 101).
FIRST USE 2-1-2011; IN COMMERCE 2-1-2011.

4,017,155. THE STARTUP STORE LLC, ATLANTA, GA. SN 85-150,346. PUB. 3-22-2011, FILED 10-12-2010.

THE STARTUP STORE

THE MARK CONSISTS OF STANDARD CHARACTERS WITHOUT CLAIM TO ANY PARTICULAR FONT, STYLE, SIZE, OR COLOR.

NO CLAIM IS MADE TO THE EXCLUSIVE RIGHT TO USE "STARTUP", APART FROM THE MARK AS SHOWN.

CLASS 35—ADVERTISING AND BUSINESS

FOR ACCOUNTING SERVICES; TAX PREPARATION, PAYROLL PROCESSING SERVICES; NEW BUSINESS VENTURE DEVELOPMENT AND FORMATION CONSULTING SERVICES (U.S. CLS. 100, 101 AND 102).
FIRST USE 4-26-2009; IN COMMERCE 4-26-2009.

CLASS 42—SCIENTIFIC AND COMPUTER SERVICES

FOR WEB SITE DESIGN SERVICES (U.S. CLS. 100 AND 101).
FIRST USE 4-26-2009; IN COMMERCE 4-26-2009.

4,017,156. THE LUTHERAN CHURCH-MISSOURI SYNOD, KIRKWOOD, MO. SN 85-150,713. PUB. 4-12-2011, FILED 10-12-2010.

THE LUTHERAN WITNESS LW

THE MARK CONSISTS OF STANDARD CHARACTERS WITHOUT CLAIM TO ANY PARTICULAR FONT, STYLE, SIZE, OR COLOR.

NO CLAIM IS MADE TO THE EXCLUSIVE RIGHT TO USE "LUTHERAN", APART FROM THE MARK AS SHOWN.

CLASS 16—PAPER GOODS AND PRINTED MATTER

FOR MAGAZINES IN THE FIELD OF RELIGION (U.S. CLS. 2, 5, 22, 23, 29, 37, 38 AND 50).
FIRST USE 1-1-2011; IN COMMERCE 1-1-2011.

CLASS 41—EDUCATION AND ENTERTAINMENT

FOR PROVIDING A WEBSITE FEATURING NON-DOWNLOADABLE PUBLICATIONS IN THE NATURE OF MAGAZINES IN THE FIELD OF RELIGION (U.S. CLS. 100, 101 AND 107).

FIRST USE 1-1-2011; IN COMMERCE 1-1-2011.

4,017,175. GLOBAL FREQUENCY MUSIC LLC, NEW YORK, NY. SN 85-161,248. PUB. 4-19-2011, FILED 10-26-2010.

Global Frequency

THE MARK CONSISTS OF STANDARD CHARACTERS WITHOUT CLAIM TO ANY PARTICULAR FONT, STYLE, SIZE, OR COLOR.

CLASS 9—ELECTRICAL AND SCIENTIFIC APPARATUS

FOR DIGITAL MATERIALS, NAMELY, DOWNLOADABLE MP3 FILES, MP3 RECORDINGS, WEBCASTS AND PODCASTS FEATURING MUSIC, ENTERTAINMENT, FASHION AND NEWS BROADCASTS (U.S. CLS. 21, 23, 26, 36 AND 38).
FIRST USE 11-1-2010; IN COMMERCE 11-1-2010.

CLASS 25—CLOTHING

FOR CLOTHING, NAMELY, T-SHIRTS, SWEATSHIRTS, POLO SHIRTS, SPORT SHIRTS, TANK TOPS, JACKETS, CAPS AND JERSEYS (U.S. CLS. 22 AND 39).
FIRST USE 3-23-2011; IN COMMERCE 3-23-2011.

CLASS 41—EDUCATION AND ENTERTAINMENT

FOR ENTERTAINMENT SERVICES, IN THE NATURE OF LIVE PERFORMANCES FEATURING MUSIC AND MUSICAL ARTISTS; ORGANIZING AND CONDUCTING MUSIC CONCERTS AND MUSIC FESTIVALS (U.S. CLS. 100, 101 AND 107).

FIRST USE 3-23-2011; IN COMMERCE 3-23-2011.

4,017,214. BRAZENN ENTERPRISES INC, EASTON, PA. SN 85-179,596. PUB. 4-5-2011, FILED 11-18-2010.

fotag

4,017,205. THE QUADRANT CORPORATION, BELLEVUE, WA. SN 85-174,031. PUB. 3-29-2011, FILED 11-10-2010.

BUILT YOUR WAY

THE MARK CONSISTS OF STANDARD CHARACTERS WITHOUT CLAIM TO ANY PARTICULAR FONT, STYLE, SIZE, OR COLOR.

CLASS 36—INSURANCE AND FINANCIAL

FOR REAL ESTATE BROKERAGE (U.S. CLS. 100, 101 AND 102).

FIRST USE 1-31-2011; IN COMMERCE 1-31-2011.

CLASS 37—CONSTRUCTION AND REPAIR

FOR BUILDING CONSTRUCTION SERVICES; REAL ESTATE DEVELOPMENT (U.S. CLS. 100, 103 AND 106).

FIRST USE 1-31-2011; IN COMMERCE 1-31-2011.

THE MARK CONSISTS OF STANDARD CHARACTERS WITHOUT CLAIM TO ANY PARTICULAR FONT, STYLE, SIZE, OR COLOR.

CLASS 6—METAL GOODS

FOR KEY FOBS OF COMMON METAL; KEYRINGS OF COMMON METAL; METAL HARDWARE, NAMELY, CARABINERS OF METAL; METAL KEY CHAINS; METAL KEY HOLDERS; METAL KEY RINGS; METAL RINGS AND CHAINS FOR KEYS (U.S. CLS. 2, 12, 13, 14, 23, 25 AND 50).

FIRST USE 12-15-2010; IN COMMERCE 2-15-2011.

CLASS 20—FURNITURE AND ARTICLES NOT OTHERWISE CLASSIFIED

FOR PICTURE AND PHOTOGRAPH FRAMES (U.S. CLS. 2, 13, 22, 25, 32 AND 50).

FIRST USE 12-15-2010; IN COMMERCE 2-15-2011.

4,017,210. PAPER MART, INC., EAST HANOVER, NJ. SN 85-177,018. PUB. 4-19-2011, FILED 11-15-2010.

MORE PAPER, MORE ENVELOPES, MORE SERVICE

THE MARK CONSISTS OF STANDARD CHARACTERS WITHOUT CLAIM TO ANY PARTICULAR FONT, STYLE, SIZE, OR COLOR.

CLASS 35—ADVERTISING AND BUSINESS

FOR DISTRIBUTORSHIP SERVICES IN THE FIELD OF STATIONERY (U.S. CLS. 100, 101 AND 102).

FIRST USE 3-22-2011; IN COMMERCE 3-22-2011.

CLASS 40—MATERIAL TREATMENT

FOR PRINTING SERVICES (U.S. CLS. 100, 103 AND 106).

FIRST USE 3-22-2011; IN COMMERCE 3-22-2011.

4,017,221. TWIN EAGLE RESOURCE MANAGEMENT, LLC, HOUSTON, TX. SN 85-184,424. PUB. 5-3-2011, FILED 11-24-2010.



NO CLAIM IS MADE TO THE EXCLUSIVE RIGHT TO USE "RESOURCE MANAGEMENT", APART FROM THE MARK AS SHOWN.

THE MARK CONSISTS OF AN IMAGE OF TWO SIDE BY SIDE EAGLE PROFILES CENTERED OVER THE WORDS "TWIN EAGLE" CENTERED OVER THE WORDS "RESOURCE MANAGEMENT".

CLASS 35—ADVERTISING AND BUSINESS

FOR BUSINESS MARKETING SERVICES IN THE FIELD OF VARIOUS PRODUCTS FOR ENERGY RELATED BUSINESSES (U.S. CLS. 100, 101 AND 102).

FIRST USE 12-1-2010; IN COMMERCE 1-1-2011.

CLASS 36—INSURANCE AND FINANCIAL

FOR COMMODITY TRADING FOR OTHERS IN THE FIELD OF VARIOUS PRODUCTS FOR ENERGY RELATED BUSINESSES (U.S. CLS. 100, 101 AND 102).

FIRST USE 12-1-2010; IN COMMERCE 1-1-2011.

4,017,222. INDUSTRIAL RIVET & FASTENER CO., NORTHVALE, NJ. SN 85-184,978. PUB. 5-3-2011, FILED 11-24-2010.

KINGSET

THE MARK CONSISTS OF STANDARD CHARACTERS WITHOUT CLAIM TO ANY PARTICULAR FONT, STYLE, SIZE, OR COLOR.

OWNER OF U.S. REG. NOS. 2,189,026, 2,191,964, AND 3,507,857.

CLASS 6—METAL GOODS

FOR METAL FASTENERS, NAMELY, RIVETS AND SPECIALTY FASTENERS (U.S. CLS. 2, 12, 13, 14, 23, 25 AND 50).

FIRST USE 3-8-2011; IN COMMERCE 3-8-2011.

CLASS 7—MACHINERY

FOR POWER-OPERATED FASTENER INSTALLATION TOOLS, NAMELY, FOR THE INSTALLATION OF RIVETS (U.S. CLS. 13, 19, 21, 23, 31, 34 AND 35).

FIRST USE 3-8-2011; IN COMMERCE 3-8-2011.

CLASS 8—HAND TOOLS

FOR HAND-OPERATED FASTENER INSTALLATION TOOLS, NAMELY, FOR THE INSTALLATION OF RIVETS (U.S. CLS. 23, 28 AND 44).

FIRST USE 3-8-2011; IN COMMERCE 3-8-2011.

4,017,224. PURPOSE JOURNEY, INC., NAPLES, FL. SN 85-186,325. PUB. 5-3-2011, FILED 11-29-2010.

PURPOSE JOURNEY

THE MARK CONSISTS OF STANDARD CHARACTERS WITHOUT CLAIM TO ANY PARTICULAR FONT, STYLE, SIZE, OR COLOR.

CLASS 16—PAPER GOODS AND PRINTED MATTER

FOR BLANK JOURNALS; EDUCATIONAL PUBLICATIONS, NAMELY, BOOKS, HAND-OUTS, WORKBOOKS, JOURNALS, WORKSHEETS, AND CARDS IN THE FIELDS OF LIFE COACHING; JOURNALS CONCERNING LIFE COACHING; PRINTED EDUCATIONAL MATERIALS IN THE FIELD OF LIFE COACHING (U.S. CLS. 2, 5, 22, 23, 29, 37, 38 AND 50).

FIRST USE 1-11-2011; IN COMMERCE 1-11-2011.

CLASS 41—EDUCATION AND ENTERTAINMENT

FOR LIFE COACHING SERVICES IN THE FIELD OF PERSONAL GROWTH AND PROFESSIONAL GROWTH; PERSONAL COACHING SERVICES IN THE FIELD OF PERSONAL GROWTH; PROVIDING GROUP COACHING AND LEARNING FORUMS IN THE FIELD OF LEADERSHIP DEVELOPMENT (U.S. CLS. 100, 101 AND 107).

FIRST USE 1-6-2011; IN COMMERCE 1-6-2011.

CLASS 42—SCIENTIFIC AND COMPUTER SERVICES

FOR PROVIDING A WEBSITE THAT ENABLES USERS TO SUBSCRIBE TO LIFE COACHING SERVICES IN THE FIELD OF PERSONAL GROWTH AND PROFESSIONAL GROWTH; PROVIDING A WEBSITE THAT ENABLES USERS TO SUBSCRIBE TO GROUP COACHING AND LEARNING FORUMS IN THE FIELD OF LEADERSHIP DEVELOPMENT (U.S. CLS. 100 AND 101).

FIRST USE 1-6-2011; IN COMMERCE 1-6-2011.

4,017,266. NAME RITE, L.L.C., TEMECULA, CA. SN 85-975,474. PUB. 11-9-2010, FILED 8-20-2010.



OWNER OF U.S. REG. NOS. 1,280,221, 3,653,223, AND OTHERS.

NO CLAIM IS MADE TO THE EXCLUSIVE RIGHT TO USE "HOME", APART FROM THE MARK AS SHOWN.

THE MARK CONSISTS OF A SHIELD DESIGN CONTAINING "RITE AID" WITH THE WORD "HOME" TO THE RIGHT, WHICH FEATURES THE LETTER "O" ENCLOSED IN A SQUARE.

CLASS 11—ENVIRONMENTAL CONTROL APPARATUS

FOR WATER FILTERS; WATER FILTRATION PITCHERS SOLD EMPTY; LIGHTERS PRIMARILY FOR LIGHTING GRILLS; FIREPLACES AND CANDLES (U.S. CLS. 13, 21, 23, 31 AND 34).

FIRST USE 3-0-2011; IN COMMERCE 3-0-2011.

CLASS 17—RUBBER GOODS

FOR MASKING TAPE (U.S. CLS. 1, 5, 12, 13, 35 AND 50).

FIRST USE 11-0-2010; IN COMMERCE 11-0-2010.

4,017,271. KANGAROO MEDIA, INC., MIRABEL, QUEBEC J7N1, CANADA. SN 85-975,480. PUB. 10-19-2010, FILED 6-4-2010.

FANVISION

THE MARK CONSISTS OF STANDARD CHARACTERS WITHOUT CLAIM TO ANY PARTICULAR FONT, STYLE, SIZE, OR COLOR.

CLASS 9—ELECTRICAL AND SCIENTIFIC APPARATUS

FOR PORTABLE MULTIMEDIA VIEWING TERMINALS FOR USE DURING SPORTING EVENTS, CULTURAL EVENTS OR GATHERINGS OF PERSONS (U.S. CLS. 21, 23, 26, 36 AND 38).
FIRST USE 9-12-2010; IN COMMERCE 9-12-2010.

CLASS 38—COMMUNICATION

FOR TRANSMISSION OF AUDIO, VIDEO AND DATA BY MEANS OF TELECOMMUNICATIONS NETWORKS OR WIRELESS COMMUNICATION NETWORKS FOR SPORTING EVENTS, CULTURAL EVENTS OR GATHERINGS OF PERSONS TO PORTABLE MULTIMEDIA VIEWING TERMINALS; AUDIO BROADCASTING; VIDEO BROADCASTING; BROADCASTING OF AUDIO, VIDEO, IMAGE AND TEXT MESSAGES PROMOTING THE WARES AND SERVICES OF OTHERS AT SPORTING EVENTS, CULTURAL EVENTS OR GATHERINGS OF PERSONS TO PORTABLE MULTIMEDIA VIEWING TERMINALS; TRANSMISSION OF AUDIO, VIDEO AND DATA OVER WIRELESS COMMUNICATION NETWORKS (U.S. CLS. 100, 101 AND 104).
FIRST USE 9-12-2010; IN COMMERCE 9-12-2010.

* * * * *

SECTION 2.— INTERNATIONAL CLASSIFICATION

The short titles associated below with the international class numbers are terms designed merely for quick identification and are not an official part of the international classification. The full names of international classes are given in section 6.1 of the trademark rules of practice.

The designation "U.S. Cl." appearing in this section refers to the U.S. class in effect prior to Sep. 1, 1973 rather than the international class which applies to applications filed on or after that date. For adoption of international classification see notice in the OFFICIAL GAZETTE of Jun. 26, 1973 (911 O.G. TM 210).

Application in one class

CLASS 1—CHEMICALS

4,016,195. SNI SOLUTIONS, INC., GENESEO, IL. SN 77-263,028. PUB. 3-23-2010, FILED 8-23-2007.

BIOMELT

THE MARK CONSISTS OF STANDARD CHARACTERS WITHOUT CLAIM TO ANY PARTICULAR FONT, STYLE, SIZE, OR COLOR.

FOR ANTI-ICING/DE-ICER, NAMELY, CHEMICAL PREPARATIONS FOR MELTING SNOW AND ICE (U.S. CLS. 1, 5, 6, 10, 26 AND 46).

FIRST USE 8-1-2007; IN COMMERCE 5-1-2010.

4,016,322. HYBRID SILICA TECHNOLOGIES, INC., CAMBRIDGE, MA. SN 77-719,954. PUB. 11-2-2010, FILED 4-22-2009.

C•SPEC

THE MARK CONSISTS OF "C SPEC" WITH A SOLID CIRCLE BETWEEN THE LETTERS "C" AND "S".

FOR SILICA NANOPARTICLES USED IN SCIENTIFIC RESEARCH; SILICA NANOPARTICLES WITH A UNIQUE FLUORESCENT COLOR OR COMBINATION OF COLORS USED IN ENERGY INDUSTRY, NAMELY, TRACING OF FLOWS OF LIQUIDS IN OIL FIELDS; SILICA NANOPARTICLES WITH A UNIQUE FLUORESCENT COLOR OR COMBINATION OF COLORS USED IN SECURITY, NAMELY, PREVENTING COUNTERFEIT GOODS BY ADDING UNIQUE FLUORESCENT COLORING OR FLUORESCENT COLOR COMBINATIONS TO THE GOODS OR PACKAGING FOR THE GOODS TO MAKE COUNTERFEITING MORE DIFFICULT (U.S. CLS. 1, 5, 6, 10, 26 AND 46).

FIRST USE 5-20-2011; IN COMMERCE 5-20-2011.

CLASS 1—(Continued).

4,016,375. LABORATOIRES GOEMAR, 35419 SAINT-MALO CEDEX, FRANCE. SN 77-789,201. PUB. 6-1-2010, FILED 7-24-2009.

HEADSET

THE MARK CONSISTS OF STANDARD CHARACTERS WITHOUT CLAIM TO ANY PARTICULAR FONT, STYLE, SIZE, OR COLOR.

FOR CHEMICAL PREPARATIONS INTENDED FOR AGRICULTURE, HORTICULTURE AND FORESTRY EXCLUDING FUNGICIDES, HERBICIDES, INSECTICIDES AND PARASITE KILLERS; FERTILIZERS; FERTILIZERS IN THE NATURE OF SEAWEED-BASED FERTILIZER PRODUCTS; SOIL AMENDMENTS, NAMELY, BIOSTIMULANTS, PHYSIOLOGICAL ACTIVATORS IN THE NATURE OF PLANT GROWTH ACTIVATORS AND FERTILIZERS FOR PLANT NUTRITION; SEAWEED-BASED CHEMICAL ACTIVATORS FOR THE NUTRITION AND GROWTH REGULATION OF PLANTS, TREES, VINES, CEREALS, FRUIT AND VEGETABLES; FERTILIZERS FOR GROWING SEAWEED (U.S. CLS. 1, 5, 6, 10, 26 AND 46).

FIRST USE 11-30-1997; IN COMMERCE 11-30-1997.

4,016,382. THE SYNTEON GROUP, PORTER, TX. SN 77-799,598. PUB. 1-5-2010, FILED 8-7-2009.

SYNTEON

THE MARK CONSISTS OF STANDARD CHARACTERS WITHOUT CLAIM TO ANY PARTICULAR FONT, STYLE, SIZE, OR COLOR.

FOR POLYMER COMPOSITIONS USED IN THE MANUFACTURE OF COMMERCIAL AND INDUSTRIAL GOODS (U.S. CLS. 1, 5, 6, 10, 26 AND 46).

FIRST USE 6-1-2011; IN COMMERCE 6-1-2011.

CLASS 1—(Continued).

4,016,383. OMS INVESTMENTS, INC., LOS ANGELES, CA. SN 77-799,605. PUB. 10-27-2009, FILED 8-7-2009.

GRO-MIX

THE MARK CONSISTS OF STANDARD CHARACTERS WITHOUT CLAIM TO ANY PARTICULAR FONT, STYLE, SIZE, OR COLOR.

FOR GROWING MEDIA FOR PLANTS (U.S. CLS. 1, 5, 6, 10, 26 AND 46).

FIRST USE 3-0-2011; IN COMMERCE 3-0-2011.

CLASS 1—(Continued).

4,016,865. PINDELL ENGINEERING LLC, PORT TOWNSEND, WA. SN 85-054,188. PUB. 11-9-2010, FILED 6-3-2010.

H2OUT

THE MARK CONSISTS OF STANDARD CHARACTERS WITHOUT CLAIM TO ANY PARTICULAR FONT, STYLE, SIZE, OR COLOR.

FOR EXSICCATING BEADS SOLD IN A CONTAINER USED ON LAND VEHICLES, AND BOATS TO REMOVE MOISTURE FROM FUEL TANKS (U.S. CLS. 1, 5, 6, 10, 26 AND 46).

FIRST USE 9-9-2010; IN COMMERCE 9-0-2010.

4,016,542. KAMIN LLC, MACON, GA. SN 77-912,226. PUB. 11-23-2010, FILED 1-14-2010.

KAMINGLOSS

THE MARK CONSISTS OF STANDARD CHARACTERS WITHOUT CLAIM TO ANY PARTICULAR FONT, STYLE, SIZE, OR COLOR.

THE ENGLISH TRANSLATION OF "KAMIN" IN THE MARK IS "FIREPLACE".

FOR CLAY PARTICLES USED IN PAPER COATING APPLICATIONS (U.S. CLS. 1, 5, 6, 10, 26 AND 46).

FIRST USE 4-1-2008; IN COMMERCE 4-1-2008.

4,017,080. MIDWEST INDUSTRIAL SUPPLY, INC., CANTON, OH. SN 85-112,033. PUB. 11-16-2010, FILED 8-20-2010.

GREENPAVE

THE MARK CONSISTS OF STANDARD CHARACTERS WITHOUT CLAIM TO ANY PARTICULAR FONT, STYLE, SIZE, OR COLOR.

FOR ORGANIC BASE AND TOP SURFACE STABILIZATION AGENTS FOR ORGANIC ROAD SURFACING AND SUBBASE STABILIZATION ON SECONDARY ROAD SURFACES, PARKING LOTS, PATRON WALKWAYS, CAMPSITES, RV PARKS, GOLF CART PATHS, BICYCLE AND WALKING TRAILS, DRIVEWAYS AND SIDEWALKS (U.S. CLS. 1, 5, 6, 10, 26 AND 46).

FIRST USE 7-1-2010; IN COMMERCE 7-1-2010.

4,016,821. JIFFY INTERNATIONAL AS, KRISTIANSAND, NORWAY. SN 85-042,401. PUB. 11-9-2010, FILED 5-19-2010.

AMERICA'S SELECT

THE MARK CONSISTS OF STANDARD CHARACTERS WITHOUT CLAIM TO ANY PARTICULAR FONT, STYLE, SIZE, OR COLOR.

FOR POTTING SOIL MIX (U.S. CLS. 1, 5, 6, 10, 26 AND 46).

FIRST USE 1-1-2011; IN COMMERCE 1-1-2011.

4,017,270. PANAX ETEC CO., LTD., BUSAN, REPUBLIC OF KOREA. SN 85-975,478. PUB. 11-16-2010, FILED 6-14-2010.

StarLyte

THE MARK CONSISTS OF STANDARD CHARACTERS WITHOUT CLAIM TO ANY PARTICULAR FONT, STYLE, SIZE, OR COLOR.

FOR ELECTROLYTE FOR ELECTRIC DOUBLE LAYER CAPACITOR, ELECTROLYTE FOR BATTERIES, ELECTROLYTE FOR LITHIUM CELL BATTERY, CHEMICAL SOLVENT USED IN ELECTROLYTE FOR LITHIUM BATTERIES, BATTERY ANTI-SULPHURIZING AGENTS (U.S. CLS. 1, 5, 6, 10, 26 AND 46).

FIRST USE 11-8-2010; IN COMMERCE 11-8-2010.

CLASS 2—PAINTS

4,016,240. MEREDITH CORPORATION, DES MOINES, IA.
SN 77-367,946. PUB. 4-15-2008, FILED 1-9-2008.

BETTER HOMES AND GARDENS

THE MARK CONSISTS OF STANDARD CHARACTERS WITHOUT CLAIM TO ANY PARTICULAR FONT, STYLE, SIZE, OR COLOR.

OWNER OF U.S. REG. NOS. 754,656, 1,573,340, AND OTHERS.

FOR PAINT, NAMELY, EXTERIOR PAINT, INTERIOR PAINT, HOUSE PAINT, ENAMEL PAINT (U.S. CLS. 6, 11 AND 16).

FIRST USE 1-20-2011; IN COMMERCE 1-20-2011.

4,016,405. TNE MEC COMPANY, INC., KANSAS CITY, MO.
SN 77-834,401. PUB. 2-16-2010, FILED 9-24-2009.

CHEMBLOC

THE MARK CONSISTS OF STANDARD CHARACTERS WITHOUT CLAIM TO ANY PARTICULAR FONT, STYLE, SIZE, OR COLOR.

OWNER OF U.S. REG. NO. 2,730,333.

FOR PAINTS (U.S. CLS. 6, 11 AND 16).

FIRST USE 2-0-2010; IN COMMERCE 2-0-2010.

4,016,860. CALIFORNIA PRODUCTS CORPORATION, AND-OVER, MA. SN 85-053,199. PUB. 10-26-2010, FILED 6-2-2010.

LOGICOLOR

THE MARK CONSISTS OF STANDARD CHARACTERS WITHOUT CLAIM TO ANY PARTICULAR FONT, STYLE, SIZE, OR COLOR.

FOR COLORANTS AND TINTS FOR PAINTS AND PRIMERS (U.S. CLS. 6, 11 AND 16).

FIRST USE 5-0-2011; IN COMMERCE 5-0-2011.

CLASS 2—(Continued).

4,016,885. EPKO INDUSTRIES, INC., ELK GROVE VILLAGE, IL. SN 85-060,029. PUB. 11-2-2010, FILED 6-10-2010.

TABRASA ULTRA

THE MARK CONSISTS OF STANDARD CHARACTERS WITHOUT CLAIM TO ANY PARTICULAR FONT, STYLE, SIZE, OR COLOR.

OWNER OF U.S. REG. NO. 3,782,610.

NO CLAIM IS MADE TO THE EXCLUSIVE RIGHT TO USE "ULTRA", APART FROM THE MARK AS SHOWN.

THE WORDING "TABRASA" HAS NO MEANING IN A FOREIGN LANGUAGE.

FOR PAINTS (U.S. CLS. 6, 11 AND 16).

FIRST USE 3-1-2010; IN COMMERCE 3-1-2010.

CLASS 3—COSMETICS AND CLEANING PREPARATIONS

4,016,148. INTERNATIONAL PRODUCTS GROUP, SOUTH JORDAN, UT. SN 76-675,662. PUB. 4-8-2008, FILED 4-18-2007.

BODY SUSHI

THE MARK CONSISTS OF STANDARD CHARACTERS WITHOUT CLAIM TO ANY PARTICULAR FONT, STYLE, SIZE, OR COLOR.

NO CLAIM IS MADE TO THE EXCLUSIVE RIGHT TO USE "BODY", APART FROM THE MARK AS SHOWN.

FOR SOAP; PERFUMERY; COSMETICS; NON-MEDICATED TOILETRIES; AROMATIC ESSENTIAL OILS; SHAMPOOS; HAIR LOTIONS; BATH SALTS, NOT FOR MEDICAL PURPOSES; LOTIONS FOR COSMETIC PURPOSES, NAMELY, BODY LOTIONS, FACIAL LOTIONS, HAND LOTIONS, FOOT LOTIONS; COSMETIC CREAMS; PREPARATIONS FOR USE ON THE HAIR, NAMELY, HAIR CARE PREPARATIONS, HAIR STYLING PREPARATIONS; NON-MEDICATED SKIN CARE PREPARATIONS; DEODORANTS FOR USE ON THE PERSON; SKIN CREAMS; NON-MEDICATED EMULSIONS, LOTIONS, BEAUTY GELS AND OILS, ALL FOR HANDS, FEET AND FACE; BEAUTY MASKS; LIQUID, PASTE AND POWDER FOUNDATIONS; MAKE-UP POWDERS; NON-MEDICATED SKIN CARE BEAUTY PRODUCTS, NAMELY, ANTI-BLEMISH PREPARATIONS, SKIN OINTMENTS, EYE TREATMENT PREPARATIONS FOR THE REMOVAL OF UNDER-EYE BAGS AND CIRCLES; SKIN CARE PRODUCTS FOR PERSONAL USE, NAMELY, FACE, EYE AND LIP MOISTURIZERS; FACE AND SKIN CREAMS; ANTI-AGING LOTIONS, SELF-TANNER LOTIONS, BEAUTY LOTIONS AND BEAUTY SERUMS (U.S. CLS. 1, 4, 6, 50, 51 AND 52).

FIRST USE 3-25-2011; IN COMMERCE 3-25-2011.

CLASS 3—(Continued).

4,016,159. OSHRY, SCOTT, LOS ANGELES, CA. SN 76-700,466. PUB. 9-28-2010, FILED 11-20-2009.

WHOLE WHEAT

THE MARK CONSISTS OF STANDARD CHARACTERS WITHOUT CLAIM TO ANY PARTICULAR FONT, STYLE, SIZE, OR COLOR.

FOR SKIN CARE PRODUCTS, NAMELY, SKIN CREAM, SKIN LOTIONS AND SOAPS; HAIR CARE PRODUCTS, NAMELY, SHAMPOO, CONDITIONER AND HAIR STYLING AIDS, NAMELY, MOUSSE, GELS AND LOTIONS; COSMETICS (U.S. CLS. 1, 4, 6, 50, 51 AND 52).

FIRST USE 3-1-2011; IN COMMERCE 3-1-2011.

4,016,162. HAZAN, RITA, NEW YORK, NY. SN 76-704,335. PUB. 2-22-2011, FILED 9-2-2010.

I CAN SEE YOUR ROOTS

THE MARK CONSISTS OF STANDARD CHARACTERS WITHOUT CLAIM TO ANY PARTICULAR FONT, STYLE, SIZE, OR COLOR.

NO CLAIM IS MADE TO THE EXCLUSIVE RIGHT TO USE "ROOTS", APART FROM THE MARK AS SHOWN.

FOR HAIR DYES, NAMELY, HAIR ROOT CONCEALERS (U.S. CLS. 1, 4, 6, 50, 51 AND 52).

FIRST USE 3-0-2011; IN COMMERCE 3-0-2011.

4,016,166. TRIUMPH PHARMACEUTICALS INC., ST. LOUIS, MO. SN 77-024,930. PUB. 9-18-2007, FILED 10-19-2006.

POWERED BY ZINC

THE MARK CONSISTS OF STANDARD CHARACTERS WITHOUT CLAIM TO ANY PARTICULAR FONT, STYLE, SIZE, OR COLOR.

NO CLAIM IS MADE TO THE EXCLUSIVE RIGHT TO USE "ZINC", APART FROM THE MARK AS SHOWN.

FOR NON-MEDICATED MOUTH RINSE, TOOTH-PASTE (U.S. CLS. 1, 4, 6, 50, 51 AND 52).

FIRST USE 5-15-2007; IN COMMERCE 8-15-2007.

CLASS 3—(Continued).

4,016,199. PRL USA HOLDINGS, INC., WILMINGTON, DE. SN 77-277,766. PUB. 4-15-2008, FILED 9-12-2007.

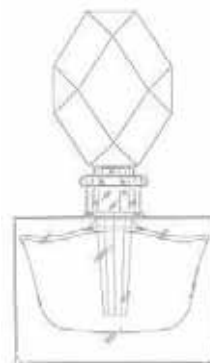

THE STIPPLING IS FOR SHADING PURPOSES ONLY. THE MARK CONSISTS OF A THREE-DIMENSIONAL CONFIGURATION OF A BOTTLE OR CONTAINER FOR THE GOODS WITH A RECTANGULAR-SHAPED BASE AND A FACETED CLEAR DIAMOND SHAPED CAP WITH A POINTED STOPPER THEREFORE.

FOR FRAGRANCES FOR PERSONAL USE (U.S. CLS. 1, 4, 6, 50, 51 AND 52).

FIRST USE 12-0-2008; IN COMMERCE 12-0-2008.

4,016,237. ILONA, INC., DENVER, CO. SN 77-358,933. PUB. 4-1-2008, FILED 12-23-2007.

DREAMLINER

THE MARK CONSISTS OF STANDARD CHARACTERS WITHOUT CLAIM TO ANY PARTICULAR FONT, STYLE, SIZE, OR COLOR.

FOR COSMETICS AND MAKEUP, NAMELY, EYE AND LIP LINERS (U.S. CLS. 1, 4, 6, 50, 51 AND 52).

FIRST USE 6-3-2010; IN COMMERCE 1-6-2011.

4,016,282. TRISH MCEVOY, LTD, NEW YORK, NY. SN 77-612,968. PUB. 9-22-2009, FILED 11-12-2008.

Trish McEvoy Line Smoother

THE MARK CONSISTS OF STANDARD CHARACTERS WITHOUT CLAIM TO ANY PARTICULAR FONT, STYLE, SIZE, OR COLOR.

OWNER OF U.S. REG. NOS. 1,541,143 AND 3,558,992.

NO CLAIM IS MADE TO THE EXCLUSIVE RIGHT TO USE "LINE SMOOTHER", APART FROM THE MARK AS SHOWN.

CLASS 3—(Continued).

THE NAME(S), PORTRAIT(S), AND/OR SIGNATURE(S) SHOWN IN THE MARK IDENTIFIES "TRISH MCEVOY", WHOSE CONSENT(S) TO REGISTER IS MADE OF RECORD.

FOR COSMETICS, NAMELY, SKIN CREAMS AND LOTIONS (U.S. CLS. 1, 4, 6, 50, 51 AND 52).

FIRST USE 11-0-2008; IN COMMERCE 11-0-2008.

4,016,283. TRISH MCEVOY, LTD, NEW YORK, NY. SN 77-613,120. PUB. 9-22-2009, FILED 11-12-2008.

Trish McEvoy Correctables

THE MARK CONSISTS OF STANDARD CHARACTERS WITHOUT CLAIM TO ANY PARTICULAR FONT, STYLE, SIZE, OR COLOR.

OWNER OF U.S. REG. NOS. 1,541,143 AND 3,558,992.

THE NAME(S), PORTRAIT(S), AND/OR SIGNATURE(S) SHOWN IN THE MARK IDENTIFIES "TRISH MCEVOY", WHOSE CONSENT(S) TO REGISTER IS MADE OF RECORD.

FOR COSMETICS, NAMELY, SKIN CREAMS, LOTIONS AND LIP GLOSS (U.S. CLS. 1, 4, 6, 50, 51 AND 52).

FIRST USE 11-0-2008; IN COMMERCE 11-0-2008.

4,016,352. SHIPMAN, MARISSA J, SAN FRANCISCO, CA. SN 77-756,872. PUB. 11-3-2009, FILED 6-10-2009.

hot ticket

THE MARK CONSISTS OF STANDARD CHARACTERS WITHOUT CLAIM TO ANY PARTICULAR FONT, STYLE, SIZE, OR COLOR.

FOR COSMETICS (U.S. CLS. 1, 4, 6, 50, 51 AND 52).

FIRST USE 6-17-2011; IN COMMERCE 6-17-2011.

CLASS 3—(Continued).

4,016,369. LUIGI DI GIROLAMO MALDERA, EDO MIRANDA, VENEZUELA. SN 77-775,449. PUB. 4-27-2010, FILED 7-7-2009.



NO CLAIM IS MADE TO THE EXCLUSIVE RIGHT TO USE "GREEN", APART FROM THE MARK AS SHOWN.

THE COLOR(S) RED, TAN, YELLOW, GREEN, BLACK, GRAY, AND WHITE IS/ARE CLAIMED AS A FEATURE OF THE MARK.

THE MARK CONSISTS OF THE WORDING "GREEN ROCK" IN GREEN AND YELLOW AND A STYLIZED BOY. THE BOY HAS GREEN HAIR, A RED TONGUE, TAN SKIN, AND BLACK AND WHITE FACIAL DETAILS. HE IS WEARING A GREEN SHIRT, RED SHORTS, BLACK AND WHITE SHOES, A BLACK WRIST BAND AND GREEN AND BLACK SUNGLASSES. HE IS CARRYING A BLACK GUITAR WITH A GREEN STRAP AND A GRAY MICROPHONE.

FOR SOAPS; PERFUMERY; ESSENTIAL OILS; COSMETICS; HAIR LOTIONS (U.S. CLS. 1, 4, 6, 50, 51 AND 52).

FIRST USE 2-18-2010; IN COMMERCE 2-18-2010.

4,016,384. LEVINE, RUSSELL, SAN DIEGO, CA. SN 77-799,983. PUB. 1-12-2010, FILED 8-7-2009.

GLITTER BUG COSMETICS

THE MARK CONSISTS OF STANDARD CHARACTERS WITHOUT CLAIM TO ANY PARTICULAR FONT, STYLE, SIZE, OR COLOR.

NO CLAIM IS MADE TO THE EXCLUSIVE RIGHT TO USE "COSMETICS", APART FROM THE MARK AS SHOWN.

FOR COSMETICS AND MAKE-UP (U.S. CLS. 1, 4, 6, 50, 51 AND 52).

FIRST USE 8-1-2010; IN COMMERCE 8-1-2010.

CLASS 3—(Continued).

4,016,412. L'OREAL USA CREATIVE, INC., NEW YORK, NY. SN 77-844,058. PUB. 5-18-2010, FILED 10-8-2009.

INTERLOCK PROTEIN NETWORK

THE MARK CONSISTS OF STANDARD CHARACTERS WITHOUT CLAIM TO ANY PARTICULAR FONT, STYLE, SIZE, OR COLOR.

NO CLAIM IS MADE TO THE EXCLUSIVE RIGHT TO USE "PROTEIN", APART FROM THE MARK AS SHOWN.

FOR A COMBINATION OF INGREDIENTS SOLD AS AN INTEGRAL COMPONENT OF HAIR CARE AND NON-MEDICATED HAIR TREATMENT PREPARATIONS (U.S. CLS. 1, 4, 6, 50, 51 AND 52).

FIRST USE 2-0-2011; IN COMMERCE 2-0-2011.

4,016,530. L'OREAL, PARIS, FRANCE. SN 77-906,771. PUB. 5-18-2010, FILED 1-7-2010.

YOKAN CRAFT

THE MARK CONSISTS OF STANDARD CHARACTERS WITHOUT CLAIM TO ANY PARTICULAR FONT, STYLE, SIZE, OR COLOR.

FOR HAIR STYLING PRODUCTS, NAMELY, STYLING PASTE (U.S. CLS. 1, 4, 6, 50, 51 AND 52).

FIRST USE 1-0-2011; IN COMMERCE 1-0-2011.

CLASS 3—(Continued).

4,016,540. BONNE SANTE LLC, OLD LYME, CT. SN 77-910,882. PUB. 11-23-2010, FILED 1-13-2010.



THE MARK CONSISTS OF THE STYLIZED TEXT "GLOW NATURALLY" WITH TWO LEAVES EMERGING FROM THE LETTER "G".

FOR ORGANIC SKINCARE AND BODYCARE PRODUCTS, NAMELY, BATH GELS; BEAUTY SERUMS; BODY CREAM; BODY LOTION; BODY MASKS; BODY OIL; BODY SCRUB; BODY SPRAYS; EYE CREAM; EYE GELS; FACIAL CLEANSERS; FACIAL CREAMS; FACIAL LOTION; FACIAL MASKS; FACIAL SCRUBS; HAIR CONDITIONERS; HAIR SHAMPOO; LIP BALM; SOAPS; FOAM BATH, SHOWER GELS, FACIAL CLEANING MILK, FACIAL WASHING GEL, FACIAL TONIC WATER, CREAMS FOR THE FACE, HAIR CARE PREPARATIONS, NAMELY, SHAMPOO, CONDITIONER (U.S. CLS. 1, 4, 6, 50, 51 AND 52).

FIRST USE 9-15-2009; IN COMMERCE 3-10-2010.

4,016,546. KAO KABUSHIKI KAISHA, AKA KAO CORPORATION, CHUO-KU, TOKYO, JAPAN. SN 77-915,045. PUB. 6-1-2010, FILED 1-19-2010.

SLEEK PERFECTION

THE MARK CONSISTS OF STANDARD CHARACTERS WITHOUT CLAIM TO ANY PARTICULAR FONT, STYLE, SIZE, OR COLOR.

FOR HAIR CARE PREPARATIONS (U.S. CLS. 1, 4, 6, 50, 51 AND 52).

FIRST USE 5-1-2011; IN COMMERCE 5-1-2011.

CLASS 3—(Continued).

4,016,547. KAO KABUSHIKI KAISHA, AKA KAO CORPORATION, CHUO-KU, TOKYO, JAPAN. SN 77-915,046. PUB. 6-1-2010, FILED 1-19-2010.

HOT FORM

THE MARK CONSISTS OF STANDARD CHARACTERS WITHOUT CLAIM TO ANY PARTICULAR FONT, STYLE, SIZE, OR COLOR.

FOR HAIR CARE PREPARATIONS (U.S. CLS. 1, 4, 6, 50, 51 AND 52).

FIRST USE 5-1-2011; IN COMMERCE 5-1-2011.

4,016,548. KAO KABUSHIKI KAISHA, AKA KAO CORPORATION, CHUO-KU, TOKYO, JAPAN. SN 77-915,060. PUB. 6-1-2010, FILED 1-19-2010.

JELLY BOOST

THE MARK CONSISTS OF STANDARD CHARACTERS WITHOUT CLAIM TO ANY PARTICULAR FONT, STYLE, SIZE, OR COLOR.

FOR HAIR CARE PREPARATIONS (U.S. CLS. 1, 4, 6, 50, 51 AND 52).

FIRST USE 5-1-2011; IN COMMERCE 5-1-2011.

4,016,549. KAO KABUSHIKI KAISHA, TA KAO CORPORATION, CHUO-KU, TOKYO, JAPAN. SN 77-915,111. PUB. 6-1-2010, FILED 1-19-2010.

STYLE SIGN

THE MARK CONSISTS OF STANDARD CHARACTERS WITHOUT CLAIM TO ANY PARTICULAR FONT, STYLE, SIZE, OR COLOR.

FOR HAIR CARE PREPARATIONS (U.S. CLS. 1, 4, 6, 50, 51 AND 52).

FIRST USE 5-1-2011; IN COMMERCE 5-1-2011.

CLASS 3—(Continued).

4,016,558. VICTORIA'S SECRET STORES BRAND MANAGEMENT, INC., REYNOLDSBURG, OH. SN 77-921,116. PUB. 5-18-2010, FILED 1-27-2010.

SHEER LOVE

THE MARK CONSISTS OF STANDARD CHARACTERS WITHOUT CLAIM TO ANY PARTICULAR FONT, STYLE, SIZE, OR COLOR.

FOR BODY BUTTER; BODY CREAMS; BODY LOTIONS; BODY SCRUB; NON-MEDICATED SKIN CARE PREPARATION, NAMELY, BODY MIST; SHOWER AND BATH GEL (U.S. CLS. 1, 4, 6, 50, 51 AND 52).

FIRST USE 5-3-2011; IN COMMERCE 5-3-2011.

4,016,560. IVY BEAUTY CORPORATION SDN. BHD., KUALA LUMPUR, MALAYSIA. SN 77-922,549. PUB. 11-23-2010, FILED 1-28-2010.

FOR TOILETRY PRODUCTS INCLUDING BODY CARE PRODUCTS, NAMELY, SHOWER CREAMS, BODY SHAMPOOS AND SOAPS, BODY LOTIONS, DEODORANTS, BODY SPRAYS, BODY MISTS, TALC, PERFUMES, COLOGNES, AND ESSENTIAL OILS; HAIR CARE PRODUCTS, NAMELY, SHAMPOOS, CONDITIONERS, CREAMS, GELS, SPRAYS, MOUSSES, SERUMS FOR COSMETIC PURPOSES, TONICS, HAIR MISTS, HAIR LOTIONS, PERMANENT WAVING AND CURLING PRODUCTS, HAIR STRENGTHENING PRODUCTS, AND HAIR COLORINGS INCLUDING HAIR DYES; SKIN CARE AND COSMETICS, NAMELY, CLEANSING MILKS, TONERS, SERUMS FOR COSMETIC PURPOSES, CREAMS, CLEANSERS, LOTIONS, MOISTURIZERS, EYE GELS, SUN CARE PRODUCTS, FACE MASKS, BEAUTY SOAPS, ANTI-PIMPLE SOAPS AND GELS, ANTI-WRINKLE GELS, MAKE-UP CREAMS AND POWDERS FOR THE FACE, LIPSTICKS, EYE SHADOWS, AND EYE AND LIP LINERS; NAIL CARE PRODUCTS INCLUDING POLISHES AND VARNISHES; FEMININE HYGIENE PRODUCTS, NAMELY, NON-MEDICATED HYGIENE WASH AND CLEANSING TOWELETTS; BABY CARE PRODUCTS, NAMELY, SHAMPOOS, SHOWER CREAMS, LOTIONS, TALCUM POWDER, AND OILS; MEN'S TOILETRY PRODUCTS, NAMELY, AFTER-SHAVE LOTIONS, PERFUMERY, POTPOURRI, FRAGRANCES, AND COSMETIC PREPARATIONS FOR SLIMMING PURPOSES; AND PERSONAL CARE PRODUCTS, NAMELY, SHAMPOOS, SHOWER CREAMS AND LOTIONS (U.S. CLS. 1, 4, 6, 50, 51 AND 52).

FIRST USE 2-12-2010; IN COMMERCE 2-12-2010.

CLASS 3—(Continued).

4,016,575. CHIPMAN, CATHERINE, BOULDER, CO. SN 77-931,730. PUB. 1-11-2011, FILED 2-9-2010.

PURASANTE VITAMIN LOTION

THE MARK CONSISTS OF STANDARD CHARACTERS WITHOUT CLAIM TO ANY PARTICULAR FONT, STYLE, SIZE, OR COLOR.

NO CLAIM IS MADE TO THE EXCLUSIVE RIGHT TO USE "VITAMIN LOTION", APART FROM THE MARK AS SHOWN.

THE ENGLISH TRANSLATION OF "PURASANTE" IN THE MARK IS "PURE HEALTH".

FOR AFTER-SUN LOTIONS; AGE RETARDANT LOTION; ANTI-AGING MOISTURIZER; AROMATHERAPY BODY CARE PRODUCTS, NAMELY, BODY LOTION, SHOWER GEL, CUTICLE CREAM, SHAMPOO, CONDITIONER, NON-MEDICATED LIP BALM, SOAP, BODY POLISH, BODY AND FOOT SCRUB AND NON-MEDICATED FOOT CREAM; AROMATHERAPY LOTIONS; BABY LOTION; BATH LOTION; BATHING LOTIONS; BEAUTY LOTIONS; BODY LOTION; BODY MASK LOTION; COSMETIC PREPARATIONS, NAMELY, FIRING LOTIONS; COSMETIC SUNTAN LOTIONS; COSMETICS IN THE FORM OF MILKS, LOTIONS AND EMULSIONS; EYE LOTIONS; FACE AND BODY LOTIONS; FACE MILK AND LOTIONS; FACIAL LOTION; HAND LOTIONS; LOTIONS FOR CELLULITE REDUCTION; LOTIONS FOR COSMETIC PURPOSES; LOTIONS FOR FACE AND BODY CARE; MASSAGE LOTIONS; NATURAL COCOA BUTTER BASED PERSONAL CARE PRODUCTS, NAMELY, BODY LOTION, SHOWER GEL, SOAP, BODY POLISH, BODY AND FOOT SCRUB AND NON-MEDICATED SKIN CREAMS; NON-MEDICATED SKIN CARE PREPARATIONS, NAMELY, CREAMS, LOTIONS, GELS, TONERS, CLEANERS AND PEELS; NON-MEDICATED STIMULATING LOTIONS FOR THE SKIN; SCENTED BODY LOTIONS AND CREAMS; SKIN AND BODY TOPICAL LOTIONS, CREAMS AND OILS FOR COSMETIC USE; SKIN LOTIONS; SKIN MOISTURIZER; SKIN MOISTURIZER MASKS; SUN CARE LOTIONS; SUN TAN LOTION; SUN-BLOCK LOTIONS; SUN-TANNING OILS AND LOTIONS; TISSUES IMPREGNATED WITH COSMETIC LOTIONS; TONING LOTION, FOR THE FACE, BODY AND HANDS (U.S. CLS. 1, 4, 6, 50, 51 AND 52).

FIRST USE 4-0-2009; IN COMMERCE 4-0-2009.

CLASS 3—(Continued).

4,016,578. NU SCENTS TRADING INC, RIDGEFIELD, NJ. SN 77-933,041. PUB. 11-9-2010, FILED 2-10-2010.

515

THE MARK CONSISTS OF STANDARD CHARACTERS WITHOUT CLAIM TO ANY PARTICULAR FONT, STYLE, SIZE, OR COLOR.

FOR COLOGNES, PERFUMES AND COSMETICS; COSMETICS IN GENERAL, INCLUDING PERFUMES; DISINFECTING PERFUMED SOAPS; EAU DE PERFUME; ESSENTIAL OILS AS PERFUME FOR LAUNDRY PURPOSES; LIQUID PERFUMES; OILS FOR PERFUMES AND SCENTS; PERFUME; PERFUME OILS; PERFUME OILS FOR THE MANUFACTURE OF COSMETIC PREPARATIONS; PERFUMED CREAMS; PERFUMED EXTRACTS FOR TISSUES AND PERFUMES; PERFUMED PASTE; PERFUMED POWDER; PERFUMED POWDERS; PERFUMED SOAP; PERFUMED SOAPS; PERFUMED TALCUM POWDER; PERFUMES (U.S. CLS. 1, 4, 6, 50, 51 AND 52).

FIRST USE 1-30-2004; IN COMMERCE 1-30-2004.

4,016,590. COLGATE-PALMOLIVE COMPANY, NEW YORK, NY. SN 77-937,601. PUB. 5-25-2010, FILED 2-17-2010.

SUAVITEL ISLAND SPLASH

THE MARK CONSISTS OF STANDARD CHARACTERS WITHOUT CLAIM TO ANY PARTICULAR FONT, STYLE, SIZE, OR COLOR.

OWNER OF U.S. REG. NOS. 2,415,599 AND 3,652,730. FOR FABRIC SOFTENER (U.S. CLS. 1, 4, 6, 50, 51 AND 52).

FIRST USE 8-1-2010; IN COMMERCE 8-1-2010.

4,016,640. AWESOME PRODUCTS, INC., BUENA PARK, CA. SN 77-956,491. PUB. 4-5-2011, FILED 3-11-2010.

TAD

THE MARK CONSISTS OF STANDARD CHARACTERS WITHOUT CLAIM TO ANY PARTICULAR FONT, STYLE, SIZE, OR COLOR.

FOR LAUNDRY DETERGENT (U.S. CLS. 1, 4, 6, 50, 51 AND 52).

FIRST USE 2-3-2010; IN COMMERCE 2-3-2010.

CLASS 3—(Continued).

4,016,652. L'OREAL USA CREATIVE, INC., NEW YORK, NY. SN 77-961,973. PUB. 5-25-2010, FILED 3-18-2010.

TOUSLE WHIP

THE MARK CONSISTS OF STANDARD CHARACTERS WITHOUT CLAIM TO ANY PARTICULAR FONT, STYLE, SIZE, OR COLOR.
FOR HAIR STYLING PREPARATION (U.S. CLS. 1, 4, 6, 50, 51 AND 52).
FIRST USE 7-1-2011; IN COMMERCE 7-1-2011.

4,016,722. PET HEAD, INC., MALIBU, CA. SN 78-939,307. PUB. 3-25-2008, FILED 7-27-2006.



THE MARK CONSISTS OF THE WORD "I" AND A HEART DESIGN FOLLOWED BY THE WORDS "PET HEAD".
FOR NON-MEDICATED GROOMING PREPARATIONS FOR CATS, DOGS, AND HOUSEHOLD PETS, NAMELY, SHAMPOOS, CONDITIONERS, BREATH FRESHENERS, DENTIFRICES AND PERFUMES (U.S. CLS. 1, 4, 6, 50, 51 AND 52).
FIRST USE 11-0-2010; IN COMMERCE 11-0-2010.

4,016,758. LA CAVIAR USA, INC., STATELINE, NV. SN 85-016,376. PUB. 11-9-2010, FILED 4-16-2010.



THE COLOR(S) WHITE, AND RED IS/ARE CLAIMED AS A FEATURE OF THE MARK.

CLASS 3—(Continued).

THE MARK CONSISTS OF A RED RECTANGLE OUTLINED IN WHITE WITH WHITE LETTERS "MD-7".
FOR COSMETIC CREAMS FOR SKIN CARE (U.S. CLS. 1, 4, 6, 50, 51 AND 52).
FIRST USE 6-29-2011; IN COMMERCE 6-29-2011.

4,016,765. CHATWOOD, TERESA, SAN ANDREAS, CA. SN 85-020,008. PUB. 10-12-2010, FILED 4-21-2010.



NO CLAIM IS MADE TO THE EXCLUSIVE RIGHT TO USE "BATH AND BODY", APART FROM THE MARK AS SHOWN.
THE COLOR(S) BLACK, BLUE, TAN AND CORAL IS/ARE CLAIMED AS A FEATURE OF THE MARK.
THE MARK CONSISTS OF "FOOTIQUE" IN BLACK OVER THE TOP OF 3 SEA SHELLS IN TAN, CORAL AND BLUE.
FOR BATH AND SHOWER GELS AND SALTS NOT FOR MEDICAL PURPOSES; BATH HERBS; BATH POWDER; BODY AND BEAUTY CARE COSMETICS; COSMETICS AND MAKE-UP; LIQUID BATH SOAPS; MAKE-UP FOR THE FACE AND BODY; MINERAL SALT IN THE NATURE OF BATH SALTS NOT FOR MEDICAL PURPOSES; NATURAL MINERAL MAKE-UP; OIL BATHS FOR HAIR CARE (U.S. CLS. 1, 4, 6, 50, 51 AND 52).
FIRST USE 4-21-2010; IN COMMERCE 6-1-2010.

4,016,837. L'OREAL, PARIS, FRANCE. SN 85-046,578. PUB. 4-26-2011, FILED 5-24-2010.



OWNER OF U.S. REG. NOS. 3,668,568 AND 3,778,026.
NO CLAIM IS MADE TO THE EXCLUSIVE RIGHT TO USE "PROFESSIONNEL" AND "KIDS", APART FROM THE MARK AS SHOWN.
THE ENGLISH TRANSLATION OF "PROFESSIONNEL", "SERIE" AND "TENDRESSE" IN THE MARK IS "PROFESSIONAL", "SERIES" AND "TENDERNESS", RESPECTIVELY.
FOR HAIR CARE PREPARATIONS FOR CHILDREN (U.S. CLS. 1, 4, 6, 50, 51 AND 52).
FIRST USE 3-1-2011; IN COMMERCE 3-1-2011.

CLASS 3—(Continued).

4,016,838. ZERRAN INTERNATIONAL CORPORATION, PA-COIMA, CA. SN 85-046,681. PUB. 10-19-2010, FILED 5-24-2010.

APS

THE MARK CONSISTS OF STANDARD CHARACTERS WITHOUT CLAIM TO ANY PARTICULAR FONT, STYLE, SIZE, OR COLOR.

FOR HAIR CARE PREPARATIONS; HAIR SHAMPOOS AND CONDITIONERS (U.S. CLS. 1, 4, 6, 50, 51 AND 52).
FIRST USE 5-16-2011; IN COMMERCE 5-16-2011.

4,016,869. LEADERS COSMETICS CO., LTD., SEOUL, REPUBLIC OF KOREA. SN 85-055,028. PUB. 11-9-2010, FILED 6-4-2010.

Leaders Insolution

THE MARK CONSISTS OF STANDARD CHARACTERS WITHOUT CLAIM TO ANY PARTICULAR FONT, STYLE, SIZE, OR COLOR.

FOR PERFUMES, EYE SHADOW, EYEBROW PENCILS, WHITE MAKE-UP POWDER, SKIN MILK LOTIONS, LIPSTICKS, CHEEK COLORS, POMADES FOR COSMETIC PURPOSES, HAIR SPRAY, BABY POWDER, SHAVING CREAMS, HAND CREAMS, BATH OIL, BABY OIL, COSMETIC SUN OILS, MASSAGE OIL, HAIR MOUSSE, BATH POWDER, PROTECTIVE PREPARATIONS FOR LIPS, LIP BRIGHTENERS, MASSAGE GEL, COSMETIC NOURISHING CREAMS, FOUNDATION CREAMS (U.S. CLS. 1, 4, 6, 50, 51 AND 52).
FIRST USE 2-11-2011; IN COMMERCE 2-11-2011.

4,016,884. BEAU BRONZ LIMITED, LONDON, SW15 1SR, UNITED KINGDOM. SN 85-059,391. PUB. 11-16-2010, FILED 6-10-2010.



BEAUBRONZ
LONDON

NO CLAIM IS MADE TO THE EXCLUSIVE RIGHT TO USE "LONDON", APART FROM THE MARK AS SHOWN.

CLASS 3—(Continued).

THE MARK CONSISTS OF A BUTTERFLY WITH ITS WINGS SPREAD OUT, FOLLOWED BY A FIRST LINE PRESENTING "BEAUBRONZ" IN ALL UPPER CASE LETTERS, FOLLOWED BY A SECOND LINE PRESENTING "LONDON" IN ALL UPPER CASE LETTERS HALF AS LARGE AS "BEAUBRONZ".

THE WORDING "BEAUBRONZ" HAS NO MEANING IN A FOREIGN LANGUAGE.

FOR COSMETIC PREPARATIONS AGAINST SUN-BURN; COSMETIC SUN-PROTECTING PREPARATIONS; COSMETIC SUN-TANNING PREPARATIONS; COSMETICS; INDOOR SUN TANNING PREPARATIONS; SELF-TANNING PREPARATIONS; SUN BLOCK PREPARATIONS; SUN SCREEN PREPARATIONS; SUN-BLOCK LOTIONS; SUN-TANNING PREPARATIONS (U.S. CLS. 1, 4, 6, 50, 51 AND 52).

FIRST USE 10-0-2007; IN COMMERCE 1-28-2009.

4,016,950. BATH & BODY WORKS BRAND MANAGEMENT, INC., REYNOLDSBURG, OH. SN 85-073,636. PUB. 11-2-2010, FILED 6-29-2010.

CARRIED AWAY

THE MARK CONSISTS OF STANDARD CHARACTERS WITHOUT CLAIM TO ANY PARTICULAR FONT, STYLE, SIZE, OR COLOR.

FOR PERSONAL CARE PRODUCTS, NAMELY, ANTI-BACTERIAL SKIN SOAPS, BATH FOAMS, BATH GELS, BATH LOTION, BATH OILS FOR COSMETIC PURPOSES, BATH SALTS, BATH SOAPS IN LIQUID, SOLID OR GEL FORM, BODY CREAM SOAP, BODY CREAMS, BODY LOTIONS, BODY OILS, BODY POWDER, BODY SCRUB, BODY SPRAY USED AS A PERSONAL DEODORANT AND AS FRAGRANCE, BODY SPRAYS, NAMELY, WATER IN ATOMIZED CONTAINERS USED TO PRODUCE A COOLING EFFECT, BODY WASHES FOR HUMANS, BUBBLE BATH, COLOGNE, HAIR CONDITIONERS, CREAM SOAPS, EAU DE PARFUM, EAU DE TOILETTE, ESSENTIAL OILS FOR PERSONAL USE, EXFOLIANT CREAMS, EXFOLIANTS FOR SKIN, FACE AND BODY CREAMS, FACE AND BODY GLITTER, FACE AND BODY LOTIONS, FACE POWDER, FACIAL BEAUTY MASKS, FACIAL CLEANSERS, FACIAL SCRUBS, FOAM BATH, FRAGRANCE EMITTING WICKS FOR ROOM FRAGRANCE, FRAGRANCES FOR AUTOMOBILES, FRAGRANCES FOR PERSONAL USE, HAIR CARE CREAMS, HAIR CARE KITS COMPRISING NON-MEDICATED HAIR CARE PREPARATIONS, NAMELY, SHAMPOO AND CONDITIONER, HAIR CONDITIONERS, HAIR GELS, HAIR POMADES, HAIR SHAMPOO, HAIR TONICS, HAND CLEANSERS, HAND CREAMS, HAND LOTIONS, HAND SOAPS, LIP BALM, LIP CREAM, LIP GLOSS, LIP GLOSS PALATTE, LIP POLISHER, LIQUID SOAPS FOR HANDS, FACE AND BODY, MASSAGE OILS, MEDICATED SOAPS, MOISTURIZING CREAMS, MOUSSE FOR HAIR, NON-MEDICATED BODY SOAKS, NON-MEDICATED FOOT CREAM, PERFUME, PERFUME OILS, PERFUMED SOAPS, ROOM FRAGRANCE REFILLS FOR NON-ELECTRIC ROOM FRAGRANCE DISPENSERS, ROOM FRAGRANCES, SCENTED BODY SPRAY, SCENTED LINEN SPRAYS, SCENTED OILS USED TO PRODUCE AROMAS WHEN HEATED, SCENTED ROOM SPRAYS, SHAVING CREAMS, SHAVING FOAMS, SHAVING GELS, SHAVING LOTIONS, SHOWER AND BATH FOAM, SHOWER CREAMS, SHOWER GELS, SKIN CLEANSERS, SKIN LOTIONS, SKIN MASKS, SKIN MOISTURIZER, SKIN SOAP, SKIN TONERS, HOME FRAGRANCE OILS AND FRAGRANCE REEDS SOLD AS A UNIT, FRAGRANT ROOM SPRAY (U.S. CLS. 1, 4, 6, 50, 51 AND 52).
FIRST USE 1-17-2011; IN COMMERCE 1-17-2011.

CLASS 3—(Continued).

4,016,956. O'BANION, JAMIE L, DALLAS, TX. SN 85-075,545. PUB. 11-23-2010, FILED 6-30-2010.

RETINOSYN

THE MARK CONSISTS OF STANDARD CHARACTERS WITHOUT CLAIM TO ANY PARTICULAR FONT, STYLE, SIZE, OR COLOR.

FOR COSMETICS (U.S. CLS. 1, 4, 6, 50, 51 AND 52).
FIRST USE 5-21-2011; IN COMMERCE 6-14-2011.

4,017,047. HARD ROCK CAFE INTERNATIONAL (USA), INC., ORLANDO, FL. SN 85-103,418. PUB. 11-2-2010, FILED 8-9-2010.

ROCK SPA

THE MARK CONSISTS OF STANDARD CHARACTERS WITHOUT CLAIM TO ANY PARTICULAR FONT, STYLE, SIZE, OR COLOR.

OWNER OF U.S. REG. NOS. 3,243,039 AND 3,626,691.
NO CLAIM IS MADE TO THE EXCLUSIVE RIGHT TO USE "SPA", APART FROM THE MARK AS SHOWN.
FOR BATH SALTS; BODY LOTION; HAIR CONDITIONER; SHAMPOOS; SHOWER AND BATH GEL; SOAPS FOR BODY CARE (U.S. CLS. 1, 4, 6, 50, 51 AND 52).

FIRST USE 9-1-2009; IN COMMERCE 9-1-2009.

4,017,077. MARTIN, HEIDI, CASCO, ME. SN 85-111,226. PUB. 2-1-2011, FILED 8-19-2010.

Mainely Cole's

THE MARK CONSISTS OF STANDARD CHARACTERS WITHOUT CLAIM TO ANY PARTICULAR FONT, STYLE, SIZE, OR COLOR.

FOR BAR SOAP; BATH SALTS; BODY LOTIONS; BODY SCRUB; FACIAL SCRUBS; POTPOURRI (U.S. CLS. 1, 4, 6, 50, 51 AND 52).

FIRST USE 11-15-2010; IN COMMERCE 11-15-2010.

CLASS 3—(Continued).

4,017,091. ALOXXI INTERNATIONAL CORPORATION, SHERMAN OAKS, CA. SN 85-116,907. PUB. 2-8-2011, FILED 8-26-2010.

ROMAN GODDESS

THE MARK CONSISTS OF STANDARD CHARACTERS WITHOUT CLAIM TO ANY PARTICULAR FONT, STYLE, SIZE, OR COLOR.

FOR HAIR BLEACHING PREPARATIONS, NON-MEDICATED HAIR CARE PREPARATIONS, HAIR CLEANING PREPARATIONS, HAIR COLOR REMOVERS, HAIR COLORING PREPARATIONS, HAIR LIGHTENERS, HAIR COLORING RINSE, HAIR LIGHTENING BLEACH, HAIR RINSES, HAIR COLORANTS, ALL IN THE FORM OF LIQUID, GEL AND CREAM (U.S. CLS. 1, 4, 6, 50, 51 AND 52).

FIRST USE 1-15-2011; IN COMMERCE 1-15-2011.

4,017,104. BACK TO AFRICA CORP., BROOKLYN, NY. SN 85-124,000. PUB. 3-8-2011, FILED 9-7-2010.



NO CLAIM IS MADE TO THE EXCLUSIVE RIGHT TO USE "SHEA NATURAL", APART FROM THE MARK AS SHOWN.

THE MARK CONSISTS OF THE TWO WORDS "SHEA" AND "NATURAL" SEPARATED BY A STYLIZED TREE.

FOR LIP BALM; SKIN MOISTURIZER; SOAPS; BATH GEL; BATH OILS; BATH BEADS; NON-MEDICATED BODY FACIAL AND SKIN CARE PREPARATIONS, NAMELY, LOTIONS, CREAMS, CLEANSERS, SCRUBS, MASKS AND TONERS; HAIR CARE PREPARATIONS; HAIR CARE AND HAIR STYLING PREPARATIONS, NAMELY, SHAMPOOS, CONDITIONERS, FINISHING SPRAY, AND GELS; PERSONAL DEODORANTS; SUN-TANNING PREPARATIONS; SUNSCREEN OILS AND LOTIONS; SHAVING PREPARATIONS; DENTIFRICES; PERFUMERIES, NAMELY, EAU DE TOILETTES, PERFUME OILS, POTPOURRI AND SACHETS; KITS AND GIFT SETS COMPRISED OF NON-MEDICATED SKIN AND HAIR CARE PREPARATIONS (U.S. CLS. 1, 4, 6, 50, 51 AND 52).

FIRST USE 10-25-2010; IN COMMERCE 10-25-2010.

CLASS 3—(Continued).

4,017,180. HOWI INC, YORKTOWN HEIGHTS, NY. SN 85-164,410. PUB. 3-29-2011, FILED 10-29-2010.



NO CLAIM IS MADE TO THE EXCLUSIVE RIGHT TO USE "SHAVE", APART FROM THE MARK AS SHOWN.

THE COLOR(S) GREY AND RED IS/ARE CLAIMED AS A FEATURE OF THE MARK.

THE MARK CONSISTS OF THE WORDS "TACONIC SHAVE" IN RED ON TOP OF A GREY WAVE MADE OF SIX HORIZONTAL LINES WHICH STARTS THIN AND BECOMES THICKER AS IT TRAVELS FROM LEFT TO RIGHT.

FOR SHAVING CREAM; SHAVING FOAM; SHAVING GELS; SHAVING LOTIONS; SHAVING MOUSSE; SHAVING PREPARATIONS; SHAVING SOAPS; SHAVING SPRITZ IN THE NATURE OF A MOISTURIZING SOLUTION FOR SHAVING (U.S. CLS. 1, 4, 6, 50, 51 AND 52).
FIRST USE 1-1-2011; IN COMMERCE 1-1-2011.

4,017,183. VICTORIA'S SECRET STORES BRAND MANAGEMENT, INC., REYNOLDSBURG, OH. SN 85-165,985. PUB. 3-8-2011, FILED 11-1-2010.

WILD ONE

THE MARK CONSISTS OF STANDARD CHARACTERS WITHOUT CLAIM TO ANY PARTICULAR FONT, STYLE, SIZE, OR COLOR.

FOR BODY CREAMS; BODY LOTIONS; BODY WASH; NON-MEDICATED SKIN CARE PREPARATION, NAMELY, BODY MIST (U.S. CLS. 1, 4, 6, 50, 51 AND 52).
FIRST USE 3-22-2011; IN COMMERCE 3-22-2011.

4,017,197. L'OREAL USA CREATIVE, INC., NEW YORK, NY. SN 85-170,366. PUB. 1-18-2011, FILED 11-5-2010.

THE FALSIES FLARED

THE MARK CONSISTS OF STANDARD CHARACTERS WITHOUT CLAIM TO ANY PARTICULAR FONT, STYLE, SIZE, OR COLOR.

OWNER OF U.S. REG. NO. 3,868,068.
FOR MASCARA (U.S. CLS. 1, 4, 6, 50, 51 AND 52).
FIRST USE 6-0-2011; IN COMMERCE 6-0-2011.

CLASS 3—(Continued).

4,017,213. BISSELL HOMECARE, INC., GRAND RAPIDS, MI. SN 85-178,911. PUB. 5-3-2011, FILED 11-17-2010.

STOMP 'N GO

THE MARK CONSISTS OF STANDARD CHARACTERS WITHOUT CLAIM TO ANY PARTICULAR FONT, STYLE, SIZE, OR COLOR.

FOR IMPREGNATED CLEANING PADS FOR TREATING CARPET AND UPHOLSTERY SPOTS AND STAINS IMPREGNATED WITH CLEANSING CHEMICALS OR COMPOUNDS FOR HOUSEHOLD USE (U.S. CLS. 1, 4, 6, 50, 51 AND 52).

FIRST USE 6-27-2011; IN COMMERCE 6-27-2011.

4,017,215. L'OREAL USA CREATIVE, INC., NEW YORK, NY. SN 85-180,821. PUB. 1-25-2011, FILED 11-19-2010.

PERFECT4PLATINUM

THE MARK CONSISTS OF STANDARD CHARACTERS WITHOUT CLAIM TO ANY PARTICULAR FONT, STYLE, SIZE, OR COLOR.

FOR HAIR CARE PREPARATIONS (U.S. CLS. 1, 4, 6, 50, 51 AND 52).

FIRST USE 6-0-2011; IN COMMERCE 6-0-2011.

4,017,263. DOTS, LLC, GLENWILLOW, OH. SN 85-975,448. PUB. 3-22-2011, FILED 10-21-2010.

BLOOM BY DOTS

THE MARK CONSISTS OF STANDARD CHARACTERS WITHOUT CLAIM TO ANY PARTICULAR FONT, STYLE, SIZE, OR COLOR.

FOR PERFUME (U.S. CLS. 1, 4, 6, 50, 51 AND 52).
FIRST USE 4-12-2011; IN COMMERCE 4-12-2011.

CLASS 4—LUBRICANTS AND FUELS

CLASS 4—(Continued).

4,016,326. HEARTHMARK, LLC, DALEVILLE, IN. SN 77-726,838. PUB. 10-20-2009, FILED 5-1-2009.



OWNER OF U.S. REG. NOS. 1,728,826, 2,825,670, AND OTHERS.

THE MARK CONSISTS OF THREE OVERLAPPING FLAMES CENTERED SYMMETRICALLY ABOVE THE LITERAL ELEMENT OF "PINE MOUNTAIN".

FOR FIRELOGS AND FIRESTARTERS MANUFACTURED PRIMARILY OF SAWDUST AND WAX (U.S. CLS. 1, 6 AND 15).

FIRST USE 9-30-2009; IN COMMERCE 9-30-2009.

4,016,523. JOHNSON, TARA, BROOKLYN, NY. SN 77-903,002. PUB. 5-18-2010, FILED 12-30-2009.

YUM-WICK

THE MARK CONSISTS OF STANDARD CHARACTERS WITHOUT CLAIM TO ANY PARTICULAR FONT, STYLE, SIZE, OR COLOR.

FOR CANDLES (U.S. CLS. 1, 6 AND 15).

FIRST USE 2-18-2011; IN COMMERCE 2-18-2011.

4,017,141. SMITH MOUNTAIN INDUSTRIES, INC., FOREST, VA. SN 85-140,665. PUB. 3-15-2011, FILED 9-29-2010.

WOODWICK ESCAPE

THE MARK CONSISTS OF STANDARD CHARACTERS WITHOUT CLAIM TO ANY PARTICULAR FONT, STYLE, SIZE, OR COLOR.

OWNER OF U.S. REG. NOS. 3,255,835, 3,258,312, AND OTHERS.

SEC. 2(F) AS TO "WOODWICK".

FOR SCENTED CANDLES (U.S. CLS. 1, 6 AND 15).

FIRST USE 2-0-2011; IN COMMERCE 2-0-2011.

CLASS 5—PHARMACEUTICALS**CLASS 5—(Continued).**

4,016,187. ISI BRANDS, INC., GRAND RAPIDS, MI. SN 77-184,791. PUB. 9-11-2007, FILED 5-18-2007.

METABO FUEL

THE MARK CONSISTS OF STANDARD CHARACTERS WITHOUT CLAIM TO ANY PARTICULAR FONT, STYLE, SIZE, OR COLOR.

FOR DIETARY SUPPLEMENTS (U.S. CLS. 6, 18, 44, 46, 51 AND 52).

FIRST USE 7-7-2011; IN COMMERCE 7-7-2011.

4,016,216. IRONWOOD PHARMACEUTICALS, INC., CAMBRIDGE, MA. SN 77-327,915. PUB. 4-22-2008, FILED 11-13-2007.

IRONWOOD

THE MARK CONSISTS OF STANDARD CHARACTERS WITHOUT CLAIM TO ANY PARTICULAR FONT, STYLE, SIZE, OR COLOR.

FOR PHARMACEUTICAL PREPARATIONS FOR USE IN THE TREATMENT OF DIGESTIVE AND GASTRO-INTESTINAL RELATED DISORDERS AND DISEASES (U.S. CLS. 6, 18, 44, 46, 51 AND 52).

FIRST USE 7-12-2011; IN COMMERCE 7-12-2011.

4,016,298. SYNGENTA PARTICIPATIONS AG, BASEL, SWITZERLAND. SN 77-648,434. PUB. 4-7-2009, FILED 1-13-2009.

Agri-Flex

THE MARK CONSISTS OF STANDARD CHARACTERS WITHOUT CLAIM TO ANY PARTICULAR FONT, STYLE, SIZE, OR COLOR.

FOR INSECTICIDES FOR AGRICULTURAL USE (U.S. CLS. 6, 18, 44, 46, 51 AND 52).

FIRST USE 6-21-2010; IN COMMERCE 6-21-2010.

CLASS 5—(Continued).

4,016,303. THIEN DUOC CO., LTD, TAN UYEN DISTRICT, BINH DUONG PROVINCE, VIETNAM. SN 77-666,741. PUB. 6-2-2009, FILED 2-9-2009.

CLASS 5—(Continued).

4,016,389. GENUINE FIRST AID LLC, CLEARWATER, FL. SN 77-812,081. PUB. 3-9-2010, FILED 8-25-2009.

CRILA

THE MARK CONSISTS OF STANDARD CHARACTERS WITHOUT CLAIM TO ANY PARTICULAR FONT, STYLE, SIZE, OR COLOR.

FOR DIETARY SUPPLEMENT CONSISTING OF PHARMACEUTICAL PLANT EXTRACT FORMULATION FOR PROSTATE AND UTERINE HEALTH (U.S. CLS. 6, 18, 44, 46, 51 AND 52).
FIRST USE 12-16-2010; IN COMMERCE 12-16-2010.

Easy Access Pocket System

THE MARK CONSISTS OF STANDARD CHARACTERS WITHOUT CLAIM TO ANY PARTICULAR FONT, STYLE, SIZE, OR COLOR.

NO CLAIM IS MADE TO THE EXCLUSIVE RIGHT TO USE "POCKET SYSTEM", APART FROM THE MARK AS SHOWN.

FOR FIRST AID KITS; FIRST AID KITS FOR DOMESTIC OR OTHER NON-PROFESSIONAL USE (U.S. CLS. 6, 18, 44, 46, 51 AND 52).
FIRST USE 6-1-2009; IN COMMERCE 6-1-2009.

4,016,304. E. I. DU PONT DE NEMOURS AND COMPANY, WILMINGTON, DE. SN 77-671,317. PUB. 5-5-2009, FILED 2-16-2009.

4,016,391. EQUITYLABS, INC., PROVIDENCE, UT. SN 77-813,477. PUB. 1-19-2010, FILED 8-26-2009.

VIEWPOINT

THE MARK CONSISTS OF STANDARD CHARACTERS WITHOUT CLAIM TO ANY PARTICULAR FONT, STYLE, SIZE, OR COLOR.

FOR HERBICIDES (U.S. CLS. 6, 18, 44, 46, 51 AND 52).
FIRST USE 10-1-2009; IN COMMERCE 5-10-2011.

IME-12

THE MARK CONSISTS OF STANDARD CHARACTERS WITHOUT CLAIM TO ANY PARTICULAR FONT, STYLE, SIZE, OR COLOR.

FOR DIETARY AND NUTRITIONAL SUPPLEMENTS (U.S. CLS. 6, 18, 44, 46, 51 AND 52).
FIRST USE 10-1-2009; IN COMMERCE 2-1-2010.

4,016,305. E. I. DU PONT DE NEMOURS AND COMPANY, WILMINGTON, DE. SN 77-671,322. PUB. 5-5-2009, FILED 2-16-2009.

4,016,406. ROTAM AGROCHEM INTERNATIONAL CO. LTD., CHAI WAN, HONG KONG. SN 77-835,342. PUB. 2-16-2010, FILED 9-25-2009.

STREAMLINE

THE MARK CONSISTS OF STANDARD CHARACTERS WITHOUT CLAIM TO ANY PARTICULAR FONT, STYLE, SIZE, OR COLOR.

FOR HERBICIDES (U.S. CLS. 6, 18, 44, 46, 51 AND 52).
FIRST USE 10-1-2009; IN COMMERCE 2-25-2011.

NUDRIN

THE MARK CONSISTS OF STANDARD CHARACTERS WITHOUT CLAIM TO ANY PARTICULAR FONT, STYLE, SIZE, OR COLOR.

FOR INSECTICIDES, PREPARATIONS FOR DESTROYING VERMIN (U.S. CLS. 6, 18, 44, 46, 51 AND 52).
FIRST USE 6-1-2011; IN COMMERCE 6-1-2011.

CLASS 5—(Continued).

4,016,430. M.D. APOTHECARY, INC., FORMERLY ORTHOPEDIC APOTHECARY, INC., WESTLAKE VILLAGE, CA. SN 77-866,867. PUB. 10-26-2010, FILED 11-6-2009.



NO CLAIM IS MADE TO THE EXCLUSIVE RIGHT TO USE "APOTHECARY", APART FROM THE MARK AS SHOWN.

THE MARK CONSISTS OF THE STYLIZED LETTERS "MD", ALL APPEARING BEHIND THE STYLIZED WORDS "M.D. APOTHECARY".

FOR DIETARY AND NUTRITIONAL SUPPLEMENTS; VITAMIN AND MINERAL SUPPLEMENTS (U.S. CLS. 6, 18, 44, 46, 51 AND 52).

FIRST USE 4-12-2010; IN COMMERCE 4-12-2010.

CLASS 5—(Continued).

4,016,456. NISSAN CHEMICAL INDUSTRIES, LTD., CHIYODO-KU, TOKYO, JAPAN. SN 77-881,110. PUB. 10-12-2010, FILED 11-25-2009.

PERMIT PLUS

THE MARK CONSISTS OF STANDARD CHARACTERS WITHOUT CLAIM TO ANY PARTICULAR FONT, STYLE, SIZE, OR COLOR.

OWNER OF U.S. REG. NO. 1,549,795.

NO CLAIM IS MADE TO THE EXCLUSIVE RIGHT TO USE "PLUS", APART FROM THE MARK AS SHOWN.

FOR HERBICIDES; PREPARATIONS FOR KILLING WEEDS (U.S. CLS. 6, 18, 44, 46, 51 AND 52).

FIRST USE 5-1-2011; IN COMMERCE 5-1-2011.

4,016,543. ON OPTIMUM NUTRITION LIMITED, KILKENNY CITY, IRELAND. SN 77-913,943. PUB. 6-1-2010, FILED 1-18-2010.



OWNER OF U.S. REG. NOS. 2,811,132, 3,114,540, AND OTHERS.

NO CLAIM IS MADE TO THE EXCLUSIVE RIGHT TO USE "PERFORMANCE", APART FROM THE MARK AS SHOWN.

THE MARK CONSISTS OF THE IMAGE OF AN EAGLE AND THE LETTERS, "ABB" FOLLOWED BY THE WORD, "PERFORMANCE".

FOR DIETARY AND NUTRITIONAL SUPPLEMENTS (U.S. CLS. 6, 18, 44, 46, 51 AND 52).

FIRST USE 3-5-2010; IN COMMERCE 3-5-2010.

4,016,435. NOVARTIS VACCINES AND DIAGNOSTICS GMBH, 35041 MARBURG, FED REP GERMANY. SN 77-870,279. PUB. 5-25-2010, FILED 11-11-2009.



THE MARK CONSISTS OF A STYLIZED "R" ON A SHIELD DESIGN THAT CASTS A SHADOW TO THE LEFT OF THE SHIELD DESIGN. THE GRAY IN THE DRAWING IS FOR SHADING PURPOSES ONLY AND DOES NOT INDICATE COLOR.

FOR VACCINES FOR HUMAN USE (U.S. CLS. 6, 18, 44, 46, 51 AND 52).

FIRST USE 6-1-2011; IN COMMERCE 6-1-2011.

4,016,550. RENEW MEDICAL, INC., PALO ALTO, CA. SN 77-917,353. PUB. 9-7-2010, FILED 1-21-2010.



THE COLOR(S) YELLOW, TURQUOISE AND GRAY IS/ ARE CLAIMED AS A FEATURE OF THE MARK.

CLASS 5—(Continued).

THE MARK CONSISTS OF THE STYLIZED WORDING "RENEW" IN THE COLOR TURQUOISE WITH A STYLIZED SUN DESIGN APPEARING ABOVE THE LETTERS "NEW" IN THE COLOR YELLOW, BOTH HAVING A SHADOW IN THE COLOR GRAY AND THE COLOR WHITE REPRESENTS TRANSPARENT AREAS AND IS NOT PART OF THE MARK.

FOR SINGLE USE ANAL INSERT DEVICE FOR THE MANAGEMENT OF ACCIDENTAL BOWEL LEAKAGE DUE TO BOWEL INCONTINENCE (U.S. CLS. 6, 18, 44, 46, 51 AND 52).

FIRST USE 5-4-2011; IN COMMERCE 5-4-2011.

4,016,591. ACETO AGRICULTURAL CHEMICALS CORPORATION, LAKE SUCCESS, NY. SN 77-937,796. PUB. 7-13-2010, FILED 2-17-2010.

GLYFINE PLUS

THE MARK CONSISTS OF STANDARD CHARACTERS WITHOUT CLAIM TO ANY PARTICULAR FONT, STYLE, SIZE, OR COLOR.

FOR HERBICIDES; HERBICIDES FOR AGRICULTURAL USE (U.S. CLS. 6, 18, 44, 46, 51 AND 52).

FIRST USE 1-2-2010; IN COMMERCE 4-9-2010.

4,016,654. INGENUS PHARMACEUTICALS, LLC, ORLANDO, FL. SN 77-963,871. PUB. 10-26-2010, FILED 3-19-2010.

INGENUS

THE MARK CONSISTS OF STANDARD CHARACTERS WITHOUT CLAIM TO ANY PARTICULAR FONT, STYLE, SIZE, OR COLOR.

THE WORDING "INGENUS" HAS NO MEANING IN A FOREIGN LANGUAGE.

FOR PHARMACEUTICALS FOR THE TREATMENT OF DISORDERS, NAMELY, CARDIOVASCULAR, NEUROLOGICAL, GASTROENTEROLOGICAL, ANXIETY, ONCOLOGY, PAIN MANAGEMENT (U.S. CLS. 6, 18, 44, 46, 51 AND 52).

FIRST USE 5-2-2011; IN COMMERCE 5-2-2011.

CLASS 5—(Continued).

4,016,657. ROSE ACRE FARMS, INC., SEYMOUR, IN. SN 77-966,832. PUB. 8-24-2010, FILED 3-24-2010.

ENVIRO-CAL

THE MARK CONSISTS OF STANDARD CHARACTERS WITHOUT CLAIM TO ANY PARTICULAR FONT, STYLE, SIZE, OR COLOR.

FOR ANIMAL FEED SUPPLEMENTS, NAMELY, MINERAL, AMINO ACID, AND ENZYME SUPPLEMENTS; MICRO-NUTRIENT ANIMAL FEED (U.S. CLS. 6, 18, 44, 46, 51 AND 52).

FIRST USE 7-1-2011; IN COMMERCE 7-1-2011.

4,016,658. ROSE ACRE FARMS, INC., SEYMOUR, IN. SN 77-966,867. PUB. 8-24-2010, FILED 3-24-2010.



THE STIPPLING IS FOR SHADING PURPOSES. THE MARK CONSISTS OF A WORLD GLOBE WITH A ROOSTER IMPRINTED OVER IT AND WITH THE WORDS "ENVIRO-CAL" PRINTED OVER THE GLOBE.

FOR ANIMAL FEED SUPPLEMENTS, NAMELY, MINERAL, AMINO ACID, AND ENZYME SUPPLEMENTS; MICRO-NUTRIENT ANIMAL FEED (U.S. CLS. 6, 18, 44, 46, 51 AND 52).

FIRST USE 7-1-2011; IN COMMERCE 7-1-2011.

4,016,659. ROSE ACRE FARMS, INC., SEYMOUR, IN. SN 77-966,874. PUB. 8-24-2010, FILED 3-24-2010.



THE STIPPLING IS FOR SHADING PURPOSES.

CLASS 5—(Continued).

THE MARK CONSISTS OF A GLOBE WITH A ROOSTER IMPRINTED OVER IT AND WITH THE WORDS "EQUA-CAL" PRINTED OVER THE GLOBE.

FOR ANIMAL FEED SUPPLEMENTS, NAMELY, MINERAL, AMINO ACID, AND ENZYME SUPPLEMENTS; MICRO-NUTRIENT ANIMAL FEED (U.S. CLS. 6, 18, 44, 46, 51 AND 52).

FIRST USE 7-1-2011; IN COMMERCE 7-1-2011.

4,016,664. ROSE ACRE FARMS, INC., SEYMOUR, IN. SN 77-968,086. PUB. 8-24-2010, FILED 3-25-2010.

EQUA-CAL

THE MARK CONSISTS OF STANDARD CHARACTERS WITHOUT CLAIM TO ANY PARTICULAR FONT, STYLE, SIZE, OR COLOR.

FOR ANIMAL FEED SUPPLEMENTS, NAMELY, MINERAL, AMINO ACID, AND ENZYME SUPPLEMENTS; MICRO-NUTRIENT ANIMAL FEED (U.S. CLS. 6, 18, 44, 46, 51 AND 52).

FIRST USE 7-1-2011; IN COMMERCE 7-1-2011.

4,016,698. AR SCIENTIFIC, INC., PHILADELPHIA, PA. SN 77-982,199. PUB. 4-27-2010, FILED 4-23-2009.



OWNER OF U.S. REG. NOS. 3,291,674 AND 3,326,075.

NO CLAIM IS MADE TO THE EXCLUSIVE RIGHT TO USE "SCIENTIFIC", APART FROM THE MARK AS SHOWN.

THE MARK CONSISTS OF THE WORDING "AR SCIENTIFIC" INSIDE A CIRCLE.

FOR MEDICINES AND MEDICAMENTS FOR THE TREATMENT AND PREVENTION OF MALARIA, BLOOD DISORDERS, NAMELY, DYSLIPIDEMIAS, RHEUMATIC DISORDERS EXCLUDING ARTHRITIS, INFLAMMATORY DISORDERS, AND METABOLIC DISORDERS, NAMELY, GOUT AND FAMILIAL MEDITERRANEAN FEVER (U.S. CLS. 6, 18, 44, 46, 51 AND 52).

FIRST USE 8-14-2009; IN COMMERCE 6-29-2010.

CLASS 5—(Continued).

4,016,751. PONDERA BIOTECHNOLOGIES, LLC, POWNAL, ME. SN 85-013,115. PUB. 9-7-2010, FILED 4-13-2010.

ENDORPHINATE

THE MARK CONSISTS OF STANDARD CHARACTERS WITHOUT CLAIM TO ANY PARTICULAR FONT, STYLE, SIZE, OR COLOR.

FOR NUTRITIONAL SUPPLEMENTS; ANALGESIC AND MUSCLE RELAXANT NUTRACEUTICAL PREPARATIONS; NUTRACEUTICAL PREPARATIONS FOR BALANCING AND RESTORATION OF HEALTHY FUNCTIONING OF THE NERVOUS SYSTEM, THE IMMUNE SYSTEM, THE CARDIO-VASCULAR SYSTEM, THE METABOLIC SYSTEM, THE RESPIRATORY SYSTEM, THE MUSCULO-SKELETAL SYSTEM, AND THE GENITOURINARY SYSTEM; NEUTRACEUTICAL PREPARATIONS FOR BALANCING AND RESTORATION OF HEALTHY INFLAMMATORY, SEXUAL, NEUROLOGICAL, GASTROINTESTINAL, HORMONAL, PSYCHIATRIC AND IMMUNE SYSTEMS AND CONDITIONS (U.S. CLS. 6, 18, 44, 46, 51 AND 52).

FIRST USE 7-8-2011; IN COMMERCE 7-8-2011.

4,016,760. HILLYARD ENTERPRISES, INC., SAINT JOSEPH, MO. SN 85-017,005. PUB. 9-28-2010, FILED 4-19-2010.

SUPROX-D

THE MARK CONSISTS OF STANDARD CHARACTERS WITHOUT CLAIM TO ANY PARTICULAR FONT, STYLE, SIZE, OR COLOR.

OWNER OF U.S. REG. NOS. 3,140,314 AND 3,140,315. FOR ALL PURPOSE DISINFECTANT FOR COMMERCIAL AND HOUSEHOLD GENERAL USE (U.S. CLS. 6, 18, 44, 46, 51 AND 52).

FIRST USE 5-1-2011; IN COMMERCE 5-1-2011.

CLASS 5—(Continued).

4,016,771. NYCOMED GMBH, 78467 KONSTANZ, FED REP GERMANY. SN 85-023,044. PUB. 7-27-2010, FILED 4-26-2010.



THE COLOR(S) YELLOW, BLUE, AND GRAY IS/ARE CLAIMED AS A FEATURE OF THE MARK.

THE MARK CONSISTS OF A STYLIZED TRIANGLE IN THE COLORS YELLOW, BLUE, AND GRAY.

FOR PHARMACEUTICAL PREPARATIONS FOR THE TREATMENT OF RESPIRATORY DISEASES; ANTI-INFLAMMATORY AGENTS (U.S. CLS. 6, 18, 44, 46, 51 AND 52).

FIRST USE 5-23-2011; IN COMMERCE 5-23-2011.

4,016,877. HERITAGE TECHNOLOGIES, LLC, INDIANAPOLIS, IN. SN 85-058,495. PUB. 11-2-2010, FILED 6-9-2010.

INTELLIBOND

THE MARK CONSISTS OF STANDARD CHARACTERS WITHOUT CLAIM TO ANY PARTICULAR FONT, STYLE, SIZE, OR COLOR.

FOR ANIMAL FEED ADDITIVES FOR USE AS A NUTRITIONAL SUPPLEMENT FOR MEDICAL PURPOSES (U.S. CLS. 6, 18, 44, 46, 51 AND 52).

FIRST USE 9-20-2010; IN COMMERCE 1-18-2011.

4,016,901. RHEONIX, INC., ITHACA, NY. SN 85-064,006. PUB. 2-15-2011, FILED 6-16-2010.

RHEONIX CARD

THE MARK CONSISTS OF STANDARD CHARACTERS WITHOUT CLAIM TO ANY PARTICULAR FONT, STYLE, SIZE, OR COLOR.

CLASS 5—(Continued).

NO CLAIM IS MADE TO THE EXCLUSIVE RIGHT TO USE "CARD", APART FROM THE MARK AS SHOWN.

FOR MEDICAL DIAGNOSTIC REAGENTS AND ASSAYS FOR TESTING BODY FLUIDS FOR MICROORGANISMS; MEDICAL DIAGNOSTIC REAGENTS AND ASSAYS FOR TESTING OF BODY FLUIDS (U.S. CLS. 6, 18, 44, 46, 51 AND 52).

FIRST USE 3-21-2011; IN COMMERCE 3-21-2011.

4,016,916. POLYMEDCO, INC., CORTLANDT MANOR, NY. SN 85-066,840. PUB. 11-16-2010, FILED 6-18-2010.

FIT-CHEK

THE MARK CONSISTS OF STANDARD CHARACTERS WITHOUT CLAIM TO ANY PARTICULAR FONT, STYLE, SIZE, OR COLOR.

OWNER OF U.S. REG. NOS. 3,005,144 AND 3,027,321.

FOR DIAGNOSTIC REAGENTS FOR CLINICAL MEDICAL LABORATORY USE IN THE FIELD OF HEMATOLOGY (U.S. CLS. 6, 18, 44, 46, 51 AND 52).

FIRST USE 9-30-2010; IN COMMERCE 9-30-2010.

4,016,946. ENTERAL HEALTH AND NUTRITION, LLC, CHESTERFIELD, MO. SN 85-072,390. PUB. 11-23-2010, FILED 6-26-2010.



NO CLAIM IS MADE TO THE EXCLUSIVE RIGHT TO USE "DERMATOLOGY HEALTH & NUTRITION", APART FROM THE MARK AS SHOWN.

THE MARK CONSISTS OF THE STYLIZED WORDING "DERMATOLOGY HEALTH & NUTRITION" SET TO THE LEFT OF A DESIGN ELEMENT COMPRISED OF TWO CRESCENT-SHAPED CURVED BANDS.

FOR DIETARY AND NUTRITIONAL SUPPLEMENTS (U.S. CLS. 6, 18, 44, 46, 51 AND 52).

FIRST USE 6-3-2011; IN COMMERCE 6-10-2011.

CLASS 5—(Continued).

4,016,962. SMARTPAK EQUINE, LLC, PLYMOUTH, MA. SN 85-076,717. PUB. 11-30-2010, FILED 7-2-2010.

SmartHA

THE MARK CONSISTS OF STANDARD CHARACTERS WITHOUT CLAIM TO ANY PARTICULAR FONT, STYLE, SIZE, OR COLOR.

FOR FEED SUPPLEMENTS FOR HORSES (U.S. CLS. 6, 18, 44, 46, 51 AND 52).
FIRST USE 7-1-2010; IN COMMERCE 8-1-2010.

CLASS 5—(Continued).

4,017,022. VIVEVITA, LLC, CHARLOTTE, NC. SN 85-092,834. PUB. 1-4-2011, FILED 7-26-2010.

KISSABOO

THE MARK CONSISTS OF STANDARD CHARACTERS WITHOUT CLAIM TO ANY PARTICULAR FONT, STYLE, SIZE, OR COLOR.

FOR WOUND DRESSINGS IN THE NATURE OF REUSABLE BANDAGES FOR CHILDREN (U.S. CLS. 6, 18, 44, 46, 51 AND 52).
FIRST USE 10-15-2010; IN COMMERCE 10-15-2010.

4,016,979. GASPARI NUTRITION, INC., LAKEWOOD, NJ. SN 85-082,371. PUB. 10-26-2010, FILED 7-12-2010.

SUPERPUMP

THE MARK CONSISTS OF STANDARD CHARACTERS WITHOUT CLAIM TO ANY PARTICULAR FONT, STYLE, SIZE, OR COLOR.

OWNER OF U.S. REG. NO. 3,063,580.
FOR DIETARY AND NUTRITIONAL SUPPLEMENTS (U.S. CLS. 6, 18, 44, 46, 51 AND 52).
FIRST USE 10-1-2010; IN COMMERCE 10-1-2010.

4,017,034. FMC CORPORATION, PHILADELPHIA, PA. SN 85-099,290. PUB. 11-16-2010, FILED 8-3-2010.

BLINDSIDE

THE MARK CONSISTS OF STANDARD CHARACTERS WITHOUT CLAIM TO ANY PARTICULAR FONT, STYLE, SIZE, OR COLOR.

FOR HERBICIDES FOR NON-AGRICULTURAL USE (U.S. CLS. 6, 18, 44, 46, 51 AND 52).
FIRST USE 3-18-2011; IN COMMERCE 3-18-2011.

4,017,016. NOVUS NUTRITION BRANDS, LLC, ST. CHARLES, MO. SN 85-090,951. PUB. 11-16-2010, FILED 7-22-2010.

COATPLUS

THE MARK CONSISTS OF STANDARD CHARACTERS WITHOUT CLAIM TO ANY PARTICULAR FONT, STYLE, SIZE, OR COLOR.

FOR NUTRITIONAL SUPPLEMENTS DESIGNED TO PROMOTE HEALTHY SKIN AND COAT FOR HORSES AND COMPANION ANIMALS (U.S. CLS. 6, 18, 44, 46, 51 AND 52).
FIRST USE 1-10-2011; IN COMMERCE 1-10-2011.

4,017,083. FMC CORPORATION, PHILADELPHIA, PA. SN 85-113,432. PUB. 11-16-2010, FILED 8-23-2010.

SQUAREONE

THE MARK CONSISTS OF STANDARD CHARACTERS WITHOUT CLAIM TO ANY PARTICULAR FONT, STYLE, SIZE, OR COLOR.

FOR HERBICIDE FOR USE ON TURF (U.S. CLS. 6, 18, 44, 46, 51 AND 52).
FIRST USE 4-7-2011; IN COMMERCE 4-7-2011.

CLASS 5—(Continued).

4,017,148. SI03, INC., CAPE GIRARDEAU, MO. SN 85-145,854.
PUB. 3-15-2011, FILED 10-5-2010.

SUPER CHAIN

THE MARK CONSISTS OF STANDARD CHARACTERS WITHOUT CLAIM TO ANY PARTICULAR FONT, STYLE, SIZE, OR COLOR.

FOR DIETARY AND NUTRITIONAL SUPPLEMENTS; DIETARY AND NUTRITIONAL SUPPLEMENTS CONTAINING LEUCIC ACID (U.S. CLS. 6, 18, 44, 46, 51 AND 52).

FIRST USE 2-17-2011; IN COMMERCE 2-17-2011.

CLASS 5—(Continued).

4,017,234. MIMEDX GROUP, INC., MARIETTA, GA. SN 85-196,194. PUB. 3-29-2011, FILED 12-13-2010.

AMNIOFIX

THE MARK CONSISTS OF STANDARD CHARACTERS WITHOUT CLAIM TO ANY PARTICULAR FONT, STYLE, SIZE, OR COLOR.

FOR IMPLANTABLE TISSUE DERIVED FROM HUMAN AMNIOTIC FLUID CELLS (U.S. CLS. 6, 18, 44, 46, 51 AND 52).

FIRST USE 1-5-2011; IN COMMERCE 1-5-2011.

4,017,187. G & G MEDICAL PRODUCTS, LLC, BRIDGETON, NJ. SN 85-167,137. PUB. 4-12-2011, FILED 11-2-2010.

SUPAIR

THE MARK CONSISTS OF STANDARD CHARACTERS WITHOUT CLAIM TO ANY PARTICULAR FONT, STYLE, SIZE, OR COLOR.

FOR INCONTINENCE PADS (U.S. CLS. 6, 18, 44, 46, 51 AND 52).

FIRST USE 1-1-2011; IN COMMERCE 1-1-2011.

CLASS 6—METAL GOODS

4,016,365. EDWARDS, SCOTT, HONG KONG, CHINA. SN 77-772,534. PUB. 4-27-2010, FILED 7-1-2009.

KHAKI ARMY

THE MARK CONSISTS OF STANDARD CHARACTERS WITHOUT CLAIM TO ANY PARTICULAR FONT, STYLE, SIZE, OR COLOR.

NO CLAIM IS MADE TO THE EXCLUSIVE RIGHT TO USE "ARMY", APART FROM THE MARK AS SHOWN.

FOR FIGURINES OF COMMON METAL (U.S. CLS. 2, 12, 13, 14, 23, 25 AND 50).

FIRST USE 6-17-2011; IN COMMERCE 6-17-2011.

4,017,226. NOVA AURORA CORPORATION, ARLINGTON, TX. SN 85-188,114. PUB. 3-8-2011, FILED 12-1-2010.

ASSIST

THE MARK CONSISTS OF STANDARD CHARACTERS WITHOUT CLAIM TO ANY PARTICULAR FONT, STYLE, SIZE, OR COLOR.

FOR NUTRITIONAL AND DIETARY SUPPLEMENTS; HOMEOPATHIC SUPPLEMENTS; WEIGHT MANAGEMENT SUPPLEMENTS; NOT SOLD THROUGH DIRECT SALES CHANNELS OF DISTRIBUTION (U.S. CLS. 6, 18, 44, 46, 51 AND 52).

FIRST USE 3-31-2011; IN COMMERCE 3-31-2011.

4,016,534. HOT EDGE, INC., NEPONSET, IL. SN 77-908,119. PUB. 5-25-2010, FILED 1-8-2010.

HOTEDGE

THE MARK CONSISTS OF STANDARD CHARACTERS WITHOUT CLAIM TO ANY PARTICULAR FONT, STYLE, SIZE, OR COLOR.

FOR METAL FLASHING, METAL CHANNEL, FASCIAE, COPING FOR BUILDING ROOFS, ROOF WIRE CLAMPS, FASTENERS (U.S. CLS. 2, 12, 13, 14, 23, 25 AND 50).

FIRST USE 6-20-2011; IN COMMERCE 6-20-2011.

CLASS 6—(Continued).

4,016,576. PAUL J. AMO, DBA KUFF ENTERPRISES LLC, SUMMERFIELD, FL. SN 77-932,391. PUB. 7-13-2010, FILED 2-10-2010.

Tuff Kuffs

THE MARK CONSISTS OF STANDARD CHARACTERS WITHOUT CLAIM TO ANY PARTICULAR FONT, STYLE, SIZE, OR COLOR.

NO CLAIM IS MADE TO THE EXCLUSIVE RIGHT TO USE "KUFFS", APART FROM THE MARK AS SHOWN.

FOR HANDCUFFS (U.S. CLS. 2, 12, 13, 14, 23, 25 AND 50).

FIRST USE 6-1-2008; IN COMMERCE 9-15-2010.

4,016,646. ILLINOIS TOOL WORKS INC., GLENVIEW, IL. SN 77-958,548. PUB. 3-22-2011, FILED 3-14-2010.

SNAPPER BOLT

THE MARK CONSISTS OF STANDARD CHARACTERS WITHOUT CLAIM TO ANY PARTICULAR FONT, STYLE, SIZE, OR COLOR.

NO CLAIM IS MADE TO THE EXCLUSIVE RIGHT TO USE "BOLT", APART FROM THE MARK AS SHOWN.

FOR METAL CLOSURES AND SEALS FOR TAMPER PROTECTION; METAL FASTENERS, NAMELY, BOLTS (U.S. CLS. 2, 12, 13, 14, 23, 25 AND 50).

FIRST USE 6-30-2008; IN COMMERCE 6-30-2008.

4,017,056. TATE ACCESS FLOORS LEASING, INC., WILMINGTON, DE. SN 85-105,722. PUB. 4-12-2011, FILED 8-12-2010.

PowerAire

THE MARK CONSISTS OF STANDARD CHARACTERS WITHOUT CLAIM TO ANY PARTICULAR FONT, STYLE, SIZE, OR COLOR.

FOR METAL ACCESS FLOOR MODULES FEATURING VENTILATING FANS (U.S. CLS. 2, 12, 13, 14, 23, 25 AND 50).

FIRST USE 10-0-2010; IN COMMERCE 10-0-2010.

CLASS 6—(Continued).

4,017,057. TATE ACCESS FLOORS LEASING, INC., WILMINGTON, DE. SN 85-105,741. PUB. 1-25-2011, FILED 8-12-2010.

DirectAire

THE MARK CONSISTS OF STANDARD CHARACTERS WITHOUT CLAIM TO ANY PARTICULAR FONT, STYLE, SIZE, OR COLOR.

FOR METAL ACCESS FLOOR PANELS; METAL ACCESS FLOOR PANELS FEATURING METAL GRATES (U.S. CLS. 2, 12, 13, 14, 23, 25 AND 50).

FIRST USE 10-0-2010; IN COMMERCE 10-0-2010.

4,017,144. U.S. POST CO., INC., SPRING GROVE, IL. SN 85-142,435. PUB. 3-15-2011, FILED 9-30-2010.

SPIN DIGGER

THE MARK CONSISTS OF STANDARD CHARACTERS WITHOUT CLAIM TO ANY PARTICULAR FONT, STYLE, SIZE, OR COLOR.

NO CLAIM IS MADE TO THE EXCLUSIVE RIGHT TO USE "SPIN", APART FROM THE MARK AS SHOWN.

FOR METAL MAILBOXES; METAL POLES; METAL POSTS (U.S. CLS. 2, 12, 13, 14, 23, 25 AND 50).

FIRST USE 6-1-2011; IN COMMERCE 6-1-2011.

4,017,207. BUSS GENERAL PARTNER CO. LTD., DBA BASEBOARDERS, DELTA, CANADA. SN 85-176,200. PUB. 4-26-2011, FILED 11-13-2010.



The logo for "Baseboarders" features the word "Baseboarders" in a bold, sans-serif font. Above the letters "BOA" in "BASEBOARDERS", there are three small circles. Below the letters "BOA", there are also three small circles, arranged in a slightly curved line.

THE MARK CONSISTS OF THE WORD "BASEBOARDERS" WITH THE OUTLINE OF THREE CIRCLES ABOVE THE LETTERS "BOA" IN "BASEBOARDERS" AND THE OUTLINE OF THREE CIRCLES BELOW.

FOR METAL VENT COVER FOR HVAC DUCTS (U.S. CLS. 2, 12, 13, 14, 23, 25 AND 50).

FIRST USE 10-15-2010; IN COMMERCE 2-15-2011.

CLASS 7—MACHINERY

CLASS 7—(Continued).

4,016,235. THE TORO COMPANY, BLOOMINGTON, MN. SN 77-353,931. PUB. 4-22-2008, FILED 12-17-2007.

EFLEX

THE MARK CONSISTS OF STANDARD CHARACTERS WITHOUT CLAIM TO ANY PARTICULAR FONT, STYLE, SIZE, OR COLOR.

FOR COMMERCIAL LAWN MOWERS INTENDED FOR USE ON GOLF GREENS, NAMELY, HIGH PRECISION WALK-BEHIND TURF MOWERS SOLD EXCLUSIVELY TO GOLF COURSES FOR USE ON GREENS (U.S. CLS. 13, 19, 21, 23, 31, 34 AND 35).

FIRST USE 2-0-2010; IN COMMERCE 2-0-2010.

CLASS 7—(Continued).

4,016,408. ENERGY EFFICIENCY SOLUTIONS, LLC, HOLLISTON, MA. SN 77-837,512. PUB. 12-7-2010, FILED 9-29-2009.



THE MARK CONSISTS OF THE WORDS "THE BURNER BOOSTER" WITH A FLAME DESIGN AFTER THE WORD "THE".

FOR APPARATUS FOR INCREASING THE EFFICIENCY OF OIL BURNING SYSTEMS COMPRISED OF A PUMP, ACCUMULATOR, PRE-HEATER, NOZZLE AND VALVES (U.S. CLS. 13, 19, 21, 23, 31, 34 AND 35).

FIRST USE 10-31-2010; IN COMMERCE 10-31-2010.

4,016,392. SEPARATION BY DESIGN, INC., EVANSVILLE, IN. SN 77-813,828. PUB. 1-11-2011, FILED 8-27-2009.

KleerBlue

THE MARK CONSISTS OF STANDARD CHARACTERS WITHOUT CLAIM TO ANY PARTICULAR FONT, STYLE, SIZE, OR COLOR.

FOR POWER-OPERATED HAND-HELD DISPENSER FOR ATTACHMENT TO LIQUID CONTAINERS FOR USE IN DISPENSING LIQUIDS (U.S. CLS. 13, 19, 21, 23, 31, 34 AND 35).

FIRST USE 8-1-2009; IN COMMERCE 8-1-2009.

4,016,464. CONAIR CORPORATION, STAMFORD, CT. SN 77-884,354. PUB. 5-11-2010, FILED 12-2-2009.



OWNER OF U.S. REG. NO. 1,930,489.
NO CLAIM IS MADE TO THE EXCLUSIVE RIGHT TO USE "MARGARITA", APART FROM THE MARK AS SHOWN.

THE MARK CONSISTS OF THE WORDS "MARGARITA" AND "MADNESS" WITH A LINE BELOW THE WORD "MARGARITA" AND BEFORE THE WORD "MADNESS".

FOR ELECTRIC FOOD BLENDERS (U.S. CLS. 13, 19, 21, 23, 31, 34 AND 35).

FIRST USE 5-0-2011; IN COMMERCE 5-0-2011.

CLASS 7—(Continued).

4,016,729. GREENLEES FILTER, LLC., FOREST PARK, IL. SN 85-002,939. PUB. 9-14-2010, FILED 3-31-2010.

EPAC

THE MARK CONSISTS OF STANDARD CHARACTERS WITHOUT CLAIM TO ANY PARTICULAR FONT, STYLE, SIZE, OR COLOR.

FOR AIR FILTERS AND AIR FILTER SYSTEMS COMPRISING AIR CLEANERS, AIR COMPRESSORS, COMPRESSED AIR STORAGE TANKS, COMPRESSED AIR DRYERS, COMPRESSED AIR FILTERS, PURGE VALVES, PRESSURE SWITCHES, HOSES AND CLAMPS FOR VEHICLE MOTORS AND ENGINES (U.S. CLS. 13, 19, 21, 23, 31, 34 AND 35).

FIRST USE 7-22-2010; IN COMMERCE 7-22-2010.

CLASS 7—(Continued).

4,016,920. ASIA VITAL COMPONENTS CO., LTD., TAIPEI COUNTY 242, TAIWAN. SN 85-067,597. PUB. 1-25-2011, FILED 6-21-2010.



THE MARK CONSISTS OF THE LETTERS "AVC" INSIDE A SHADED RECTANGLE INSIDE A RECTANGLE.

FOR HEAT EXCHANGERS BEING PARTS OF MACHINES; HEAT SINKS FOR USE IN MACHINES; AXIAL FAN CONDENSERS; AIR-COOLED CONDENSERS; AND RADIATORS FOR COOLING MACHINES AND ENGINES (U.S. CLS. 13, 19, 21, 23, 31, 34 AND 35).

FIRST USE 1-1-2011; IN COMMERCE 1-1-2011.

4,016,924. WASTE MANAGEMENT, INC., HOUSTON, TX. SN 85-068,039. PUB. 11-16-2010, FILED 6-21-2010.

SMARTENERGY

THE MARK CONSISTS OF STANDARD CHARACTERS WITHOUT CLAIM TO ANY PARTICULAR FONT, STYLE, SIZE, OR COLOR.

FOR TRASH COMPACTORS (U.S. CLS. 13, 19, 21, 23, 31, 34 AND 35).

FIRST USE 7-7-2011; IN COMMERCE 7-7-2011.

4,016,730. GREENLEES FILTER, LLC., FOREST PARK, IL. SN 85-002,966. PUB. 9-14-2010, FILED 3-31-2010.

EPAC SYSTEM

THE MARK CONSISTS OF STANDARD CHARACTERS WITHOUT CLAIM TO ANY PARTICULAR FONT, STYLE, SIZE, OR COLOR.

NO CLAIM IS MADE TO THE EXCLUSIVE RIGHT TO USE "SYSTEM", APART FROM THE MARK AS SHOWN.

FOR AIR FILTERS AND AIR FILTER SYSTEMS COMPRISING AIR CLEANERS, AIR COMPRESSORS, COMPRESSED AIR STORAGE TANKS, COMPRESSED AIR DRYERS, COMPRESSED AIR FILTERS, PURGE VALVES, PRESSURE SWITCHES, HOSES AND CLAMPS FOR VEHICLE MOTORS AND ENGINES (U.S. CLS. 13, 19, 21, 23, 31, 34 AND 35).

FIRST USE 7-22-2010; IN COMMERCE 7-22-2010.

4,016,960. CALMER CORN HEADS, INC., AKA CALMER CORN HEADS, ALPHA, IL. SN 85-076,618. PUB. 2-8-2011, FILED 7-1-2010.

Calmer BT Chopper

THE MARK CONSISTS OF STANDARD CHARACTERS WITHOUT CLAIM TO ANY PARTICULAR FONT, STYLE, SIZE, OR COLOR.

NO CLAIM IS MADE TO THE EXCLUSIVE RIGHT TO USE "BT CHOPPER", APART FROM THE MARK AS SHOWN.

FOR AGRICULTURAL MACHINERY, NAMELY, HARVESTERS; MACHINE PARTS, NAMELY, STALK ROLLS FOR COMBINE CORN HEADS (U.S. CLS. 13, 19, 21, 23, 31, 34 AND 35).

FIRST USE 9-1-2010; IN COMMERCE 12-1-2010.

CLASS 7—(Continued).

4,016,967. CARLISLE INTANGIBLE COMPANY, SYRACUSE, NY. SN 85-078,459. PUB. 11-16-2010, FILED 7-6-2010.

THE RIGHT BELT FOR THE JOB

THE MARK CONSISTS OF STANDARD CHARACTERS WITHOUT CLAIM TO ANY PARTICULAR FONT, STYLE, SIZE, OR COLOR.

FOR TRANSMISSION BELTS (U.S. CLS. 13, 19, 21, 23, 31, 34 AND 35).

FIRST USE 4-0-2011; IN COMMERCE 4-0-2011.

4,017,051. BLOUNT, INC., PORTLAND, OR. SN 85-104,382. PUB. 11-23-2010, FILED 8-10-2010.

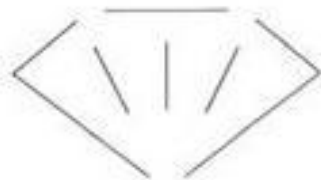

THE MARK CONSISTS OF A DIAMOND SHAPED DESIGN.

FOR SAW CHAIN FOR CHAIN SAWS (U.S. CLS. 13, 19, 21, 23, 31, 34 AND 35).

FIRST USE 5-0-2010; IN COMMERCE 5-0-2010.

4,017,262. TOP TOBACCO L.P., GLENVIEW, IL. SN 85-975,443. PUB. 12-7-2010, FILED 7-9-2010.



THE MARK CONSISTS OF A DESIGN OF A TRIANGLE WITHIN A CIRCLE IN BETWEEN THE STYLIZED TERMS OF "MIKR" AND "MATIC".

FOR CIGARETTE MAKING MACHINES (U.S. CLS. 13, 19, 21, 23, 31, 34 AND 35).

FIRST USE 7-1-2011; IN COMMERCE 7-1-2011.

CLASS 7—(Continued).

4,017,265. TOP TOBACCO L.P., GLENVIEW, IL. SN 85-975,470. PUB. 12-7-2010, FILED 7-8-2010.

MIKROMATIC

THE MARK CONSISTS OF STANDARD CHARACTERS WITHOUT CLAIM TO ANY PARTICULAR FONT, STYLE, SIZE, OR COLOR.

FOR CIGARETTE MAKING MACHINES (U.S. CLS. 13, 19, 21, 23, 31, 34 AND 35).

FIRST USE 7-1-2011; IN COMMERCE 7-1-2011.

CLASS 8—HAND TOOLS

4,016,385. COBLE, JAMES J., COLUMBIA, SC. AND DQC INTERNATIONAL, TAICHUNG, TAIWAN. SN 77-800,242. PUB. 1-12-2010, FILED 8-8-2009.



THE MARK CONSISTS OF THE NUMBER "6" AND THE WORDS "SIXTH SENSE". THE NUMBER "6" IS DEPICTED AS A GRAPHIC CHARACTER WITH CROSS HAIRS COMING FROM THE SIDES AND BOTTOM.

FOR HUNTING KNIVES (U.S. CLS. 23, 28 AND 44).

FIRST USE 10-10-2009; IN COMMERCE 12-5-2010.

4,016,726. BLUE GRASS CUTLERY, MANCHESTER, OH. SN 85-002,373. PUB. 8-24-2010, FILED 3-30-2010.

BLUE GRASS

THE MARK CONSISTS OF STANDARD CHARACTERS WITHOUT CLAIM TO ANY PARTICULAR FONT, STYLE, SIZE, OR COLOR.

SEC. 2(F).

FOR CUTLERY, NAMELY, KNIVES; FILES; FISHING KNIVES; FOLDING KNIVES; HAND TOOLS, NAMELY, FILES; HAND TOOLS, NAMELY, RASPS; HAND TOOLS, NAMELY, SCREWDRIVERS; HAND TOOLS, NAMELY, WIRE CUTTERS; HUNTING KNIVES; JACK KNIVES; LEATHER SHEATHS FOR KNIVES; NAIL FILES; NAIL SCISSORS; PLIERS; SCALING KNIVES; SCISSORS; SCREWDRIVERS; SPORT KNIVES; TOOL HOLDERS; UTILITY KNIVES; WHITTLING KNIVES; WIRE CUTTERS; WORKING KNIVES (U.S. CLS. 23, 28 AND 44).

FIRST USE 6-21-2011; IN COMMERCE 6-21-2011.

CLASS 8—(Continued).

4,016,966. TV WINNERS, INC., MADISON, NJ. SN 85-078,235. PUB. 11-30-2010, FILED 7-6-2010.

EVERLAST

THE MARK CONSISTS OF STANDARD CHARACTERS WITHOUT CLAIM TO ANY PARTICULAR FONT, STYLE, SIZE, OR COLOR.
FOR CHEF KNIVES (U.S. CLS. 23, 28 AND 44).
FIRST USE 9-1-2010; IN COMMERCE 9-1-2010.

CLASS 9—ELECTRICAL AND SCIENTIFIC APPARATUS

4,016,151. SCHWING AMERICA, INC., WHITE BEAR LAKE, MN. SN 76-694,523. PUB. 10-6-2009, FILED 11-28-2008.

SMART DRUM

THE MARK CONSISTS OF STANDARD CHARACTERS WITHOUT CLAIM TO ANY PARTICULAR FONT, STYLE, SIZE, OR COLOR.
NO CLAIM IS MADE TO THE EXCLUSIVE RIGHT TO USE "SMART", APART FROM THE MARK AS SHOWN.
FOR ELECTRONIC CONTROLLERS FOR CONCRETE MIXER TRUCKS (U.S. CLS. 21, 23, 26, 36 AND 38).
FIRST USE 1-0-2007; IN COMMERCE 1-0-2007.

4,016,154. INTERSTATE INDUSTRIES, INC., LOVINGSTON, VA. SN 76-697,561. PUB. 10-6-2009, FILED 5-26-2009.

HEART-SYNC

THE MARK CONSISTS OF STANDARD CHARACTERS WITHOUT CLAIM TO ANY PARTICULAR FONT, STYLE, SIZE, OR COLOR.
OWNER OF U.S. REG. NO. 2,643,765.
FOR DIGITAL MEDIA, NAMELY, DOWNLOADABLE AUDIO FILES FEATURING MUSIC AND CONTENT FOR MENTAL CONDITIONING, SLEEP, HEALING AND RELAXATION TECHNIQUES (U.S. CLS. 21, 23, 26, 36 AND 38).
FIRST USE 3-20-2011; IN COMMERCE 3-20-2011.

CLASS 9—(Continued).

4,016,155. INTERSTATE INDUSTRIES, INC., LOVINGSTON, VA. SN 76-697,562. PUB. 10-6-2009, FILED 5-26-2009.

HEMI-SYNC

THE MARK CONSISTS OF STANDARD CHARACTERS WITHOUT CLAIM TO ANY PARTICULAR FONT, STYLE, SIZE, OR COLOR.
OWNER OF U.S. REG. NOS. 2,752,799, 3,015,866, AND OTHERS.
FOR DIGITAL MEDIA, NAMELY, DOWNLOADABLE AUDIO FILES FEATURING MUSIC AND CONTENT FOR MENTAL CONDITIONING AND RELAXATION TECHNIQUES (U.S. CLS. 21, 23, 26, 36 AND 38).
FIRST USE 3-20-2011; IN COMMERCE 3-20-2011.

4,016,156. INTERSTATE INDUSTRIES, INC., LOVINGSTON, VA. SN 76-697,564. PUB. 10-6-2009, FILED 5-26-2009.

METAMUSIC

THE MARK CONSISTS OF STANDARD CHARACTERS WITHOUT CLAIM TO ANY PARTICULAR FONT, STYLE, SIZE, OR COLOR.
OWNER OF U.S. REG. NOS. 1,408,298 AND 2,887,040.
FOR DIGITAL MEDIA, NAMELY, DOWNLOADABLE AUDIO FILES FEATURING MUSIC AND CONTENT FOR MENTAL CONDITIONING, RELAXATION TECHNIQUES AND HUMAN MENTAL PROCESSES (U.S. CLS. 21, 23, 26, 36 AND 38).
FIRST USE 3-20-2011; IN COMMERCE 3-20-2011.

4,016,157. INTERSTATE INDUSTRIES, INC., LOVINGSTON, VA. SN 76-697,565. PUB. 10-6-2009, FILED 5-26-2009.

MIND FOOD

THE MARK CONSISTS OF STANDARD CHARACTERS WITHOUT CLAIM TO ANY PARTICULAR FONT, STYLE, SIZE, OR COLOR.
OWNER OF U.S. REG. NO. 2,387,780.
FOR DIGITAL MEDIA, NAMELY, DOWNLOADABLE AUDIO FILES FEATURING MUSIC AND CONTENT FOR MENTAL CONDITIONING, SLEEP AND RELAXATION TECHNIQUES (U.S. CLS. 21, 23, 26, 36 AND 38).
FIRST USE 3-20-2011; IN COMMERCE 3-20-2011.

CLASS 9—(Continued).

4,016,185. ENEXITY, INC., DBA SECURELINK, AUSTIN, TX. SN 77-167,457. PUB. 3-15-2011, FILED 4-27-2007.

SECURELINKX

THE MARK CONSISTS OF STANDARD CHARACTERS WITHOUT CLAIM TO ANY PARTICULAR FONT, STYLE, SIZE, OR COLOR.

OWNER OF U.S. REG. NO. 3,723,769.

FOR COMPUTER NETWORK, DATA CENTER AND INTERNET INFRASTRUCTURE EQUIPMENT MANAGEMENT DEVICES, NAMELY, SECURE CONSOLES SERVERS, TERMINAL SERVERS, REMOTE ACCESS SERVERS, REMOTE POWER CONTROL UNITS, REMOTE KVM AND KVM OVER IP SERVERS; AND SERVER MANAGEMENT HARDWARE AND ENABLING SOFTWARE SOLD AS A SINGLE UNIT THAT PROVIDE SECURE REMOTE ACCESS, CONTROL AND MANAGEMENT OVER ANY COMMUNICATIONS MEDIA IN THE NATURE OF TELEPHONE COMMUNICATION SWITCHES, MODEMS AND ROUTERS, T-1 DATA COMMUNICATIONS TERMINALS, WIRELESS, LAN, WAN, AND WLAN DEVICES (U.S. CLS. 21, 23, 26, 36 AND 38).

FIRST USE 2-1-2004; IN COMMERCE 7-1-2004.

4,016,206. DIGILIFE LTD., AUSTIN, TX. SN 77-310,703. PUB. 4-15-2008, FILED 10-23-2007.

Backup Buddy

THE MARK CONSISTS OF STANDARD CHARACTERS WITHOUT CLAIM TO ANY PARTICULAR FONT, STYLE, SIZE, OR COLOR.

NO CLAIM IS MADE TO THE EXCLUSIVE RIGHT TO USE "BACKUP", APART FROM THE MARK AS SHOWN.

FOR COMPUTER SOFTWARE FOR DATA BACKUP, RESTORE, AND RECOVERY (U.S. CLS. 21, 23, 26, 36 AND 38).

FIRST USE 7-1-2011; IN COMMERCE 7-1-2011.

CLASS 9—(Continued).

4,016,217. PACIFIC BIOSCIENCES OF CALIFORNIA, INC., MENLO PARK, CA. SN 77-328,258. PUB. 10-14-2008, FILED 11-13-2007.

SMRT

THE MARK CONSISTS OF STANDARD CHARACTERS WITHOUT CLAIM TO ANY PARTICULAR FONT, STYLE, SIZE, OR COLOR.

FOR LABORATORY INSTRUMENTS FOR SCIENTIFIC RESEARCH, NAMELY, OPTICAL DETECTORS FOR GENETIC SEQUENCING AND BIOCHEMICAL ANALYSIS (U.S. CLS. 21, 23, 26, 36 AND 38).

FIRST USE 2-24-2010; IN COMMERCE 2-24-2010.

4,016,225. HIGH IMPACT TECHNOLOGY, TIGARD, OR. SN 77-345,898. PUB. 5-6-2008, FILED 12-6-2007.

BattleView

THE MARK CONSISTS OF STANDARD CHARACTERS WITHOUT CLAIM TO ANY PARTICULAR FONT, STYLE, SIZE, OR COLOR.

FOR PROTECTIVE ARMOR PANELS FOR PROTECTING AGAINST BALLISTIC PROJECTILES AND EXPLOSIVE FRAGMENTS INSTALLED IN OR ATTACHED TO VEHICLES, BUILDINGS OR OTHER STRUCTURES (U.S. CLS. 21, 23, 26, 36 AND 38).

FIRST USE 6-24-2011; IN COMMERCE 6-24-2011.

4,016,236. ROSETTA STONE LTD., HARRISONBURG, VA. SN 77-354,767. PUB. 12-9-2008, FILED 12-18-2007.

ROSETTA

THE MARK CONSISTS OF STANDARD CHARACTERS WITHOUT CLAIM TO ANY PARTICULAR FONT, STYLE, SIZE, OR COLOR.

OWNER OF U.S. REG. NOS. 2,761,492 AND 2,781,324.

FOR COMPUTER SOFTWARE FOR TEACHING FOREIGN LANGUAGES; COMPUTER SOFTWARE FOR LEARNING FOREIGN LANGUAGES (U.S. CLS. 21, 23, 26, 36 AND 38).

FIRST USE 7-21-2009; IN COMMERCE 7-21-2009.

CLASS 9—(Continued).

4,016,241. MELLO COMMUNICATIONS, LLC, NASHUA, NH. SN 77-369,919. PUB. 8-19-2008, FILED 1-11-2008.

CLASS 9—(Continued).

4,016,255. MARVELL WORLD TRADE LTD., ST. MICHAEL, BARBADOS. SN 77-454,603. PUB. 9-23-2008, FILED 4-22-2008.

THE MISSING PIECE

THE MARK CONSISTS OF STANDARD CHARACTERS WITHOUT CLAIM TO ANY PARTICULAR FONT, STYLE, SIZE, OR COLOR.

FOR EDUCATIONAL INSTRUCTIONAL VIDEO RECORDINGS GEARED TO ASSIST DENTAL PROFESSIONALS IN EFFECTIVE COMMUNICATIONS WITH PATIENTS (U.S. CLS. 21, 23, 26, 36 AND 38).

FIRST USE 6-30-2011; IN COMMERCE 6-30-2011.

LINKCRYPT

THE MARK CONSISTS OF STANDARD CHARACTERS WITHOUT CLAIM TO ANY PARTICULAR FONT, STYLE, SIZE, OR COLOR.

FOR SEMICONDUCTORS, INTEGRATED CIRCUITS, AND SOFTWARE INCORPORATING ALGORITHMS FOR USE IN THE ENCRYPTION AND DECRYPTION OF NETWORK AND DATA COMMUNICATIONS (U.S. CLS. 21, 23, 26, 36 AND 38).

FIRST USE 4-0-2010; IN COMMERCE 4-0-2010.

4,016,245. C AND C DESIGN TECHNOLOGY, LLC, PALM BEACH GARDENS, NY. SN 77-394,085. PUB. 8-26-2008, FILED 2-11-2008.

4,016,257. TAJBAKSHI, FARIBORZ, OAK PARK, CA. SN 77-470,377. PUB. 10-14-2008, FILED 5-9-2008.

**compuchair**

THE COLOR(S) RED, BLACK AND WHITE IS/ARE CLAIMED AS A FEATURE OF THE MARK.

THE MARK CONSISTS OF A BLACK OVAL WITH THE MARK "THE WEDGI" SUPERIMPOSED IN WHITE AND THE "E" IS RED AND THE DOT OVER THE "I" IS RED.

FOR REMOVABLE STAND FOR PORTABLE ELECTRONIC DEVICES (U.S. CLS. 21, 23, 26, 36 AND 38).

FIRST USE 6-1-2010; IN COMMERCE 6-1-2010.

THE MARK CONSISTS OF STANDARD CHARACTERS WITHOUT CLAIM TO ANY PARTICULAR FONT, STYLE, SIZE, OR COLOR.

FOR AN ERGONOMICALLY DESIGNED COMPUTER STAND WHICH ATTACHES TO A CHAIR AND PROVIDES FOR A WORK ENVIRONMENT THAT FACILITATES PROLONGED USE OF ANY TYPE OF COMPUTER, LAPTOP COMPUTER, OR RELATED DEVICE (U.S. CLS. 21, 23, 26, 36 AND 38).

FIRST USE 11-16-2010; IN COMMERCE 3-23-2011.

CLASS 9—(Continued).

4,016,260. MOTOROLA TRADEMARK HOLDINGS, LLC, LIBERTYVILLE, IL. SN 77-472,686. PUB. 4-7-2009, FILED 5-13-2008.

EVOKE

THE MARK CONSISTS OF STANDARD CHARACTERS WITHOUT CLAIM TO ANY PARTICULAR FONT, STYLE, SIZE, OR COLOR.

FOR TELEPHONES, CELLULAR TELEPHONES, PERSONAL DIGITAL ASSISTANTS, PORTABLE AUDIO AND VIDEO PLAYERS, ELECTRONIC MESSAGE DEVICES, ELECTRONIC CAMERAS, NAMELY, DIGITAL CAMERAS, VIDEO CAMERAS; COMPUTER E-COMMERCE SOFTWARE TO ALLOW USER TO SAFELY PLACE ORDERS AND MAKE PAYMENTS IN THE FIELD OF ELECTRONIC BUSINESS TRANSACTIONS VIA A GLOBAL COMPUTER NETWORK, TELECOMMUNICATIONS NETWORK OR WIRELESS SIGNALS ORIGINATING IN TELECOMMUNICATION EQUIPMENT, NAMELY, RADIO MODEMS; GLOBAL POSITIONING UNITS, BATTERIES, BATTERY CHARGES AND POWER ADAPTERS (U.S. CLS. 21, 23, 26, 36 AND 38).

FIRST USE 6-7-2009; IN COMMERCE 6-7-2009.

CLASS 9—(Continued).

4,016,264. MARVELL WORLD TRADE LTD., ST. MICHAEL, BARBADOS. SN 77-478,591. PUB. 4-14-2009, FILED 5-19-2008.

CARRIERSPAN

THE MARK CONSISTS OF STANDARD CHARACTERS WITHOUT CLAIM TO ANY PARTICULAR FONT, STYLE, SIZE, OR COLOR.

FOR SEMICONDUCTORS, INTEGRATED CIRCUITS, AND SOFTWARE INCORPORATING ALGORITHMS FOR USE IN THE ENCRYPTION AND DECRYPTION OF NETWORK AND DATA COMMUNICATIONS; SEMICONDUCTORS, INTEGRATED CIRCUITS, CIRCUIT BOARDS; SOFTWARE FOR DATA AND SIGNAL PROCESSING FOR USE WITH PRINTERS, IMAGING, VIDEO, DIGITAL VIDEO, VIDEO PROCESSING, DIGITAL SUBSCRIBER LINES (DSL); FORMATTER BOARDS, NAMELY, INFORMATION FORMAT EXCHANGE AND CONTROLLER CIRCUIT BOARDS; MICROPROCESSORS, MICROCONTROLLERS, SOFTWARE FOR DATA AND SIGNAL PROCESSING FOR USE WITH EMBEDDED MICROPROCESSOR AND MICROCONTROLLER APPLICATIONS; DISK DRIVE COMPONENTS, NAMELY, READ CHANNEL INTEGRATED CIRCUITS, SYSTEM-ON-CHIP INTEGRATED CIRCUITS, PREAMPLIFIERS, INTERFACES, MOTOR CONTROLLERS AND INTEGRATED CIRCUIT COMPONENTS FOR DISC DRIVES; PRE-AMPLIFIERS; READ CHANNELS, NAMELY, INTEGRATED CIRCUITS INCORPORATING ALGORITHMS THAT TRANSFORM PHYSICAL SIGNAL INFORMATION INTO LOGICAL DATA INFORMATION; POWER MANAGEMENT CIRCUIT BOARDS AND MICROPROCESSORS, COMMUNICATION MICROPROCESSORS, CELLULAR MICROPROCESSORS, TELEPHONY CIRCUIT BOARDS; DISK DRIVE CIRCUIT BOARDS; DATA COMMUNICATION PROCESSORS, BOTH WIRED AND WIRELESS; MICROPROCESSORS FOR MULTIMEDIA APPLICATIONS; REFERENCE DESIGN AND DEVELOPMENT SYSTEMS COMPRISING CIRCUIT BOARDS, CHIPS, COMPUTER PERIPHERALS, INTERFACES, AND 802.11 WIRELESS LOCAL AREA NETWORK DEVICES (U.S. CLS. 21, 23, 26, 36 AND 38).

FIRST USE 1-0-2010; IN COMMERCE 1-0-2010.

4,016,279. UNITED BUSINESS MEDIA LLC, MANHASSET, NY. SN 77-602,364. PUB. 4-27-2010, FILED 10-28-2008.

CLOUD CONNECT

THE MARK CONSISTS OF STANDARD CHARACTERS WITHOUT CLAIM TO ANY PARTICULAR FONT, STYLE, SIZE, OR COLOR.

CLASS 9—(Continued).

NO CLAIM IS MADE TO THE EXCLUSIVE RIGHT TO USE "CLOUD", APART FROM THE MARK AS SHOWN.

FOR DOWNLOADABLE AUDIO AND VIDEO FILES FEATURING INFORMATION RELATED TO WORKING AWAY FROM THE OFFICE AT REMOTE LOCATIONS, REMOTE DESKTOPS AND SERVER VIRTUALIZATION, COMPUTING, GRID COMPUTING, GRID STORAGE, CLOUD STORAGE, AND ACCESSING PRIVATE FILES FROM REMOTE COMPUTERS AND REMOTE LOCATIONS; DOWNLOADABLE WEBCASTS FEATURING NEWS AND INFORMATION IN THE FIELDS OF HIGH TECHNOLOGY, BUSINESS TECHNOLOGY, AND INFORMATION TECHNOLOGY RELATED TO WORKING AWAY FROM THE OFFICE AT REMOTE LOCATIONS, REMOTE DESKTOPS AND SERVER VIRTUALIZATION, COMPUTING, GRID COMPUTING, GRID STORAGE, CLOUD STORAGE, AND ACCESSING PRIVATE FILES FROM REMOTE COMPUTERS AND REMOTE LOCATIONS (U.S. CLS. 21, 23, 26, 36 AND 38).

FIRST USE 11-30-2008; IN COMMERCE 6-17-2011.

4,016,280. AUGMENTIX CORPORATION, AUSTIN, TX. SN 77-604,258. PUB. 5-5-2009, FILED 10-30-2008.

PRIMOSEAL

THE MARK CONSISTS OF STANDARD CHARACTERS WITHOUT CLAIM TO ANY PARTICULAR FONT, STYLE, SIZE, OR COLOR.

FOR LAPTOP AND NOTEBOOK COMPUTERS; MOBILE COMPUTERS; TABLET COMPUTERS; CONVERTIBLE COMPUTERS; COMPUTER HARDWARE; SEALING FEATURES COMPRISED OF SPECIALIZED COMPRESSION GASKETS AND DRAINS THAT PROTECT AGAINST DUST, SAND AND LIQUID SOLD AS AN INTEGRAL COMPONENT OF MOBILE COMPUTERS (U.S. CLS. 21, 23, 26, 36 AND 38).

FIRST USE 3-13-2009; IN COMMERCE 3-13-2009.

4,016,294. 3-GIS, LLC, DBA 3-GIS, DECATUR, AL. SN 77-641,920. PUB. 10-13-2009, FILED 12-31-2008.

3-GIS Network Express

THE MARK CONSISTS OF STANDARD CHARACTERS WITHOUT CLAIM TO ANY PARTICULAR FONT, STYLE, SIZE, OR COLOR.

NO CLAIM IS MADE TO THE EXCLUSIVE RIGHT TO USE "NETWORK", APART FROM THE MARK AS SHOWN.

FOR COMPUTER SOFTWARE FOR THE DATA BASING, VISUALIZATION, MANIPULATION, VIRTUAL REALITY IMMERSION AND INTEGRATION OF GEOGRAPHIC INFORMATION WITH ON-LINE MEMBER COMMUNITIES, COMPUTER SOFTWARE THAT PROVIDES WEB-BASED ACCESS TO APPLICATIONS AND SERVICES THROUGH A WEB OPERATING SYSTEM OR PORTAL INTERFACE (U.S. CLS. 21, 23, 26, 36 AND 38).

FIRST USE 1-1-2007; IN COMMERCE 1-1-2007.

CLASS 9—(Continued).

4,016,295. 3-GIS, LLC, DBA 3-GIS, DECATUR, AL. SN 77-641,950. PUB. 10-13-2009, FILED 12-31-2008.

3-GIS Express Conductor

THE MARK CONSISTS OF STANDARD CHARACTERS WITHOUT CLAIM TO ANY PARTICULAR FONT, STYLE, SIZE, OR COLOR.

FOR COMPUTER SOFTWARE FOR CONTROLLING AND MANAGING ACCESS SERVER APPLICATIONS; COMPUTER SOFTWARE FOR BACK END CONFIGURATION OF GEOGRAPHICAL INFORMATION SYSTEMS FIELD AND WEB TOOLS; COMPUTER SOFTWARE, NAMELY, SOFTWARE DEVELOPMENT TOOLS FOR THE CREATION OF MOBILE INTERNET APPLICATIONS AND CLIENT INTERFACES; NETWORK ACCESS SERVER OPERATING SOFTWARE (U.S. CLS. 21, 23, 26, 36 AND 38).

FIRST USE 10-1-2006; IN COMMERCE 10-1-2006.

4,016,297. ARISTOCRAT TECHNOLOGIES AUSTRALIA PTY LTD, NORTH RYDE, NSW, AUSTRALIA. SN 77-646,652. PUB. 8-25-2009, FILED 1-9-2009.

THE BUTLER DID IT!

THE MARK CONSISTS OF STANDARD CHARACTERS WITHOUT CLAIM TO ANY PARTICULAR FONT, STYLE, SIZE, OR COLOR.

PRIORITY CLAIMED UNDER SEC. 44(D) ON AUSTRALIA APPLICATION NO. 1254148, FILED 7-30-2008, REG. NO. 1254148, DATED 7-30-2008, EXPIRES 7-30-2018.

FOR GAMING MACHINES (U.S. CLS. 21, 23, 26, 36 AND 38).

FIRST USE 12-1-2009; IN COMMERCE 12-1-2009.

4,016,302. NEWLINE SOFTWARE, INC., REDMOND, WA. SN 77-666,446. PUB. 12-29-2009, FILED 2-9-2009.

NEWLINE SOFTWARE, INC.

THE MARK CONSISTS OF STANDARD CHARACTERS WITHOUT CLAIM TO ANY PARTICULAR FONT, STYLE, SIZE, OR COLOR.

CLASS 9—(Continued).

NO CLAIM IS MADE TO THE EXCLUSIVE RIGHT TO USE "INC", APART FROM THE MARK AS SHOWN.

FOR COMPUTER PROGRAMS, NAMELY, SOFTWARE TO FACILITATE COMPUTER BACKUP AND RECOVERY; AND SOFTWARE TO ENABLE DIAGNOSIS, AUTOMATION, TROUBLESHOOTING, MAINTENANCE AND REPAIR OF COMPUTER (U.S. CLS. 21, 23, 26, 36 AND 38).

FIRST USE 8-11-2008; IN COMMERCE 8-11-2008.

CLASS 9—(Continued).

4,016,347. ALULI, KALE F., KILAUEA, HI. SN 77-751,462. PUB. 8-17-2010, FILED 6-3-2009.

4,016,335. DAVESARTS INDUSTRIES LLC, NEW YORK, NY. SN 77-740,669. PUB. 10-27-2009, FILED 5-19-2009.

ELLIPTICUS

THE MARK CONSISTS OF STANDARD CHARACTERS WITHOUT CLAIM TO ANY PARTICULAR FONT, STYLE, SIZE, OR COLOR.

FOR COMPUTER CALENDAR PROGRAMS (U.S. CLS. 21, 23, 26, 36 AND 38).

FIRST USE 6-2-2011; IN COMMERCE 6-2-2011.

THE MARK CONSISTS OF STANDARD CHARACTERS WITHOUT CLAIM TO ANY PARTICULAR FONT, STYLE, SIZE, OR COLOR.

FOR PRERECORDED CDS FEATURING MUSIC (U.S. CLS. 21, 23, 26, 36 AND 38).

FIRST USE 7-8-2011; IN COMMERCE 7-8-2011.

4,016,344. NINTENDO OF AMERICA INC., REDMOND, WA. SN 77-749,707. PUB. 11-9-2010, FILED 6-2-2009.

FLIPNOTE STUDIO

THE MARK CONSISTS OF STANDARD CHARACTERS WITHOUT CLAIM TO ANY PARTICULAR FONT, STYLE, SIZE, OR COLOR.

FOR COMPUTER GAME PROGRAMS; COMPUTER GAME SOFTWARE; ELECTRONIC GAME PROGRAMS; ELECTRONIC GAME SOFTWARE; INTERACTIVE GAME PROGRAMS; INTERACTIVE GAME SOFTWARE; INTERACTIVE VIDEO GAME PROGRAMS; INTERACTIVE VIDEO GAME SOFTWARE; VIDEO GAME PROGRAMS; VIDEO GAME SOFTWARE; DOWNLOADABLE MULTIMEDIA FILES, NAMELY, GAMES; DOWNLOADABLE COMPUTER GAME PROGRAMS; DOWNLOADABLE COMPUTER GAME SOFTWARE; DOWNLOADABLE ELECTRONIC GAME PROGRAMS; DOWNLOADABLE ELECTRONIC GAME SOFTWARE; DOWNLOADABLE INTERACTIVE ELECTRONIC GAME PROGRAMS; DOWNLOADABLE INTERACTIVE GAME SOFTWARE; DOWNLOADABLE VIDEO GAME PROGRAMS, DOWNLOADABLE VIDEO GAME SOFTWARE (U.S. CLS. 21, 23, 26, 36 AND 38).

FIRST USE 8-12-2009; IN COMMERCE 8-12-2009.

4,016,353. PRONUX GMBH, DBA PRONUX, AFFOLTERN AM ALBIS, SWITZERLAND. SN 77-757,023. PUB. 1-25-2011, FILED 6-11-2009.

Massive Dynamics

THE MARK CONSISTS OF STANDARD CHARACTERS WITHOUT CLAIM TO ANY PARTICULAR FONT, STYLE, SIZE, OR COLOR.

FOR OPEN SOURCE AND INTERNET E-COMMERCE SOFTWARE FOR USE IN COMMERCIAL CUSTOMER RELATIONSHIP MANAGEMENT (CRM), SPECIFICALLY, FOR DEALING WITH CUSTOMERS MAKING PURCHASES OVER THE INTERNET, COMPUTER SOFTWARE FOR ENTERPRISE RESOURCE PLANNING (ERP), SPECIFICALLY, FOR DATA BACKUP AND DATA DELIVERY FOR COMPANIES ENGAGED IN E-COMMERCE, COMPUTER SOFTWARE FOR USE IN OPERATING MOBILE PHONE SYSTEMS THAT ARE USED IN INTERNET E-COMMERCE TRANSACTIONS (U.S. CLS. 21, 23, 26, 36 AND 38).

FIRST USE 2-25-2006; IN COMMERCE 1-6-2008.

CLASS 9—(Continued).

4,016,362. NETGEAR, INC., SAN JOSE, CA. SN 77-768,084. PUB. 10-20-2009, FILED 6-25-2009.

GENIE

THE MARK CONSISTS OF STANDARD CHARACTERS WITHOUT CLAIM TO ANY PARTICULAR FONT, STYLE, SIZE, OR COLOR.

FOR COMPUTER SOFTWARE TO MONITOR INTERNET, WIRELESS AND PC CONNECTIVITY STATUS; COMPUTER SOFTWARE TO DIAGNOSE AND REPAIR NETWORK CONNECTIVITY PROBLEMS; COMPUTER SOFTWARE THAT FACILITATES ACCESS TO AND MODIFICATION OF SSID AND SECURITY OF ROUTERS; COMPUTER SOFTWARE TO FACILITATE FIRMWARE UPGRADES; COMPUTER SOFTWARE THAT FACILITATES REMOTE ACCESS OF COMPUTER SYSTEMS BY TECHNICAL SUPPORT TECHNICIANS TO HELP DEBUG PROBLEMS; COMPUTER SOFTWARE TO IMPLEMENT AND ADJUST PARENTAL CONTROL OVER CHILDREN'S INTERNET ACCESS (U.S. CLS. 21, 23, 26, 36 AND 38).

FIRST USE 9-0-2009; IN COMMERCE 9-0-2009.

4,016,401. NEATO ROBOTICS, INC., MOUNTAIN VIEW, CA. SN 77-826,842. PUB. 5-4-2010, FILED 9-15-2009.

RPS TECHNOLOGY

THE MARK CONSISTS OF STANDARD CHARACTERS WITHOUT CLAIM TO ANY PARTICULAR FONT, STYLE, SIZE, OR COLOR.

NO CLAIM IS MADE TO THE EXCLUSIVE RIGHT TO USE "TECHNOLOGY", APART FROM THE MARK AS SHOWN.

FOR ROBOTS FOR HOUSEHOLD PURPOSES AND MAINTENANCE AND STRUCTURAL PARTS AND/OR PARTS THEREOF; CAR WASHING ROBOTS FOR PERSONAL USE AND STRUCTURAL PARTS AND/OR PARTS THEREOF; PERSONAL USE AND HOBBY USE ROBOTS AND STRUCTURAL PARTS AND/OR PARTS THEREOF (U.S. CLS. 21, 23, 26, 36 AND 38).

FIRST USE 1-0-2010; IN COMMERCE 1-0-2010.

CLASS 9—(Continued).

4,016,403. GAME ARTS CO., LTD., TOKYO, JAPAN. SN 77-831,352. PUB. 6-15-2010, FILED 9-21-2009.

THE MAGIC OBELISK

THE MARK CONSISTS OF STANDARD CHARACTERS WITHOUT CLAIM TO ANY PARTICULAR FONT, STYLE, SIZE, OR COLOR.

FOR DOWNLOADABLE GAME PROGRAMS FOR CONSUMER VIDEO GAMES; CONSUMER VIDEO GAME PROGRAMS (U.S. CLS. 21, 23, 26, 36 AND 38).

FIRST USE 12-28-2009; IN COMMERCE 12-28-2009.

4,016,409. IGT, RENO, NV. SN 77-839,097. PUB. 2-23-2010, FILED 10-1-2009.

VOLCANIC SEVENS

THE MARK CONSISTS OF STANDARD CHARACTERS WITHOUT CLAIM TO ANY PARTICULAR FONT, STYLE, SIZE, OR COLOR.

NO CLAIM IS MADE TO THE EXCLUSIVE RIGHT TO USE "SEVENS", APART FROM THE MARK AS SHOWN.

FOR GAMING MACHINES, NAMELY, DEVICES WHICH ACCEPT A WAGER (U.S. CLS. 21, 23, 26, 36 AND 38).

FIRST USE 6-23-2010; IN COMMERCE 6-23-2010.

4,016,469. FLECKY, DAN E. ; VILLALBA, GASTON, DBA MALU, HUNTINGTON BEACH CA., CA. SN 77-886,645. PUB. 8-24-2010, FILED 12-4-2009.

MALU

THE MARK CONSISTS OF STANDARD CHARACTERS WITHOUT CLAIM TO ANY PARTICULAR FONT, STYLE, SIZE, OR COLOR.

FOR CASES FOR EYEGLASSES AND SUNGLASSES; CASES FOR SPECTACLES AND SUNGLASSES; FRAMES FOR SPECTACLES AND SUNGLASSES; LENSES FOR SUNGLASSES; NOSE GUARDS WHICH CAN BE WORN BY ATTACHMENT TO EYEWEAR SUCH AS SUNGLASSES AND SKI GOGGLES; PROTECTIVE CLOTHING AND HEADGEAR; SPECTACLES AND SUNGLASSES; SUNGLASS CHAINS AND CORDS; SUNGLASS LENSES; SUNGLASSES; SUNGLASSES AND SPECTACLES (U.S. CLS. 21, 23, 26, 36 AND 38).

FIRST USE 9-15-2010; IN COMMERCE 2-15-2011.

CLASS 9—(Continued).

4,016,503. CITRIX SYSTEMS, INC., FORT LAUDERDALE, FL. SN 77-895,265. PUB. 5-18-2010, FILED 12-16-2009.

XENCLIEN

THE MARK CONSISTS OF STANDARD CHARACTERS WITHOUT CLAIM TO ANY PARTICULAR FONT, STYLE, SIZE, OR COLOR.

OWNER OF U.S. REG. NOS. 3,195,200, 3,599,110, AND OTHERS.

FOR COMPUTER SOFTWARE FOR OPERATING SYSTEM, APPLICATION AND DESKTOP VIRTUALIZATION; COMPUTER SOFTWARE TO FACILITATE DELIVERY OF SOFTWARE APPLICATIONS, OPERATING SYSTEMS AND DESKTOPS ACROSS MULTIPLE PLATFORMS; COMPUTER SOFTWARE USED TO DELIVER, DEPLOY AND MANAGE SOFTWARE APPLICATIONS AND DATA OVER COMPUTERS NETWORKS; OPERATING SYSTEM SOFTWARE THAT FACILITATES APPLICATION DEPLOYMENT, MANAGEMENT, SECURITY AND ACCESS ACROSS ENTERPRISE NETWORKS AND GLOBAL COMPUTER NETWORKS (U.S. CLS. 21, 23, 26, 36 AND 38).

FIRST USE 10-5-2010; IN COMMERCE 10-5-2010.

4,016,520. MAEDA, PHILIP, TORRANCE, CA. SN 77-901,380. PUB. 11-2-2010, FILED 12-28-2009.

RYDEEN

THE MARK CONSISTS OF STANDARD CHARACTERS WITHOUT CLAIM TO ANY PARTICULAR FONT, STYLE, SIZE, OR COLOR.

THE ENGLISH TRANSLATION OF THE JAPANESE WORD "RYDEEN" (TRANSLITERATED) IS "GOD OF THUNDER".

FOR VEHICLE NAVIGATION SYSTEMS IN THE NATURE OF ON-BOARD COMPUTERS; AUDIO EQUIPMENT FOR VEHICLES, NAMELY, STEREOS, AM/FM RECEIVERS, SATELLITE RADIO RECEIVERS, EQUALIZERS, AMPLIFIERS, SPEAKERS, SPEAKER HOUSINGS, MULTI-CHANNEL LOUD SPEAKER SYSTEMS, CROSSOVERS, AND DIGITAL SIGNAL PROCESSORS; DIGITAL CAMERAS; CELL PHONES; VIDEO RECORDERS AND PLAYERS, NAMELY, DVD RECORDERS AND PLAYERS; AND CD RECORDERS AND PLAYERS (U.S. CLS. 21, 23, 26, 36 AND 38).

FIRST USE 2-0-2010; IN COMMERCE 2-0-2010.

CLASS 9—(Continued).

4,016,524. TEXAS SCIENTIFIC PRODUCTS, FLOWER MOUND, TX. SN 77-904,322. PUB. 11-16-2010, FILED 1-4-2010.

OPTIMIST

THE MARK CONSISTS OF STANDARD CHARACTERS WITHOUT CLAIM TO ANY PARTICULAR FONT, STYLE, SIZE, OR COLOR.

FOR NEBULIZER FOR SCIENTIFIC USE (U.S. CLS. 21, 23, 26, 36 AND 38).

FIRST USE 5-7-2011; IN COMMERCE 5-7-2011.

4,016,532. JACO ENTERPRISES, INC., PHOENIX, AZ. SN 77-907,611. PUB. 5-25-2010, FILED 1-8-2010.



NO CLAIM IS MADE TO THE EXCLUSIVE RIGHT TO USE "EAR", APART FROM THE MARK AS SHOWN.

FOR PROTECTIVE EAR COVERINGS FOR SWIMMERS IN THE NATURE OF A HEADBAND USED TO COVER EARPLUGS (U.S. CLS. 21, 23, 26, 36 AND 38).

FIRST USE 5-16-2011; IN COMMERCE 5-16-2011.

4,016,537. SCHIOLDAN, KIM, HENDERSON, NV. SN 77-909,108. PUB. 5-25-2010, FILED 1-11-2010.

Pharma-Safe

THE MARK CONSISTS OF STANDARD CHARACTERS WITHOUT CLAIM TO ANY PARTICULAR FONT, STYLE, SIZE, OR COLOR.

FOR ELECTRONIC SAFES (U.S. CLS. 21, 23, 26, 36 AND 38).

FIRST USE 7-13-2011; IN COMMERCE 7-13-2011.

CLASS 9—(Continued).

4,016,583. NAMCO BANDAI GAMES INC., TOKYO 140-8590, JAPAN. SN 77-935,028. PUB. 5-18-2010, FILED 2-12-2010.

TIME CRISIS 2ND STRIKE

THE MARK CONSISTS OF STANDARD CHARACTERS WITHOUT CLAIM TO ANY PARTICULAR FONT, STYLE, SIZE, OR COLOR.

FOR COMPUTER GAME PROGRAMS; COMPUTER GAME PROGRAMS, CARTRIDGES, AND CASSETTES; COMPUTER GAME SOFTWARE; DOWNLOADABLE COMPUTER GAME PROGRAMS; DOWNLOADABLE COMPUTER GAME SOFTWARE VIA A GLOBAL COMPUTER NETWORK AND WIRELESS DEVICES; VIDEO GAME CARTRIDGES; VIDEO GAME DISCS; VIDEO GAME SOFTWARE (U.S. CLS. 21, 23, 26, 36 AND 38).

FIRST USE 3-2-2011; IN COMMERCE 3-2-2011.

4,016,589. RAHBAR-DEGHAN, FARIBORZ, CANMORE, CANADA. SN 77-937,470. PUB. 11-9-2010, FILED 2-17-2010.

QUASAR

THE MARK CONSISTS OF STANDARD CHARACTERS WITHOUT CLAIM TO ANY PARTICULAR FONT, STYLE, SIZE, OR COLOR.

PRIORITY CLAIMED UNDER SEC. 44(D) ON CANADA APPLICATION NO. 1451713, FILED 9-3-2009, REG. NO. TMA776,022, DATED 9-1-2010, EXPIRES 9-1-2025.

FOR MAGNIFYING GLASSES FOR DUST DETECTION (U.S. CLS. 21, 23, 26, 36 AND 38).

FIRST USE 4-6-2010; IN COMMERCE 4-6-2010.

4,016,596. KATSMAN, DIANA, SHERMAN OAKS, CA. AND GIOEV, DIMITRI, AKA GIOYEV, DMITRIY, SHERMAN OAKS, CA. SN 77-940,916. PUB. 8-24-2010, FILED 2-21-2010.

Mobilizing Education

THE MARK CONSISTS OF STANDARD CHARACTERS WITHOUT CLAIM TO ANY PARTICULAR FONT, STYLE, SIZE, OR COLOR.

CLASS 9—(Continued).

NO CLAIM IS MADE TO THE EXCLUSIVE RIGHT TO USE "EDUCATION", APART FROM THE MARK AS SHOWN.

FOR CHILDREN'S EDUCATIONAL SOFTWARE; COMMUNICATION HUBS; COMMUNICATION SOFTWARE FOR PROVIDING ACCESS TO THE INTERNET; COMPUTER DATABASE MANAGEMENT SOFTWARE FOR USE IN PERSONALIZING THE CONTENT OF E-MAIL COMMUNICATIONS; COMPUTER GAME SOFTWARE; COMPUTER GAME SOFTWARE DOWNLOADABLE FROM A GLOBAL COMPUTER NETWORK; COMPUTER GAME SOFTWARE FOCUSING ON ACHIEVING A SET OF GOALS, POSITIONS, OWNERSHIP, AND CREDENTIALS, AND PROFESSIONAL AND SOCIAL STATUS, AND GOOD FORTUNE NECESSARY TO SUCCEED PROFESSIONALLY AND PERSONALLY, AND NOT REFERRING EITHER TO A GROUP OF SOFTWARE FOR USE IN COMMERCE OR TO A GROUP OF OFFICES; COMPUTER GAME SOFTWARE FOR PERSONAL COMPUTERS AND HOME VIDEO GAME CONSOLES; COMPUTER GAME SOFTWARE FOR USE ON MOBILE AND CELLULAR PHONES; COMPUTER HARDWARE AND COMPUTER SOFTWARE PROGRAMS FOR THE INTEGRATION OF TEXT, AUDIO, GRAPHICS, STILL IMAGES AND MOVING PICTURES INTO AN INTERACTIVE DELIVERY FOR MULTIMEDIA APPLICATIONS; COMPUTER HARDWARE AND PERIPHERAL DEVICES AND COMPUTER SOFTWARE FOR DATA COMMUNICATION AND TRANSLATING AND TRANSMITTING DATA SOLD THEREWITH; COMPUTER HARDWARE AND SOFTWARE USED FOR THE CONTROL OF VOICE CONTROLLED INFORMATION AND COMMUNICATION DEVICES; COMPUTER HARDWARE FOR COMMUNICATING AUDIO, VIDEO AND DATA BETWEEN COMPUTERS VIA A GLOBAL COMPUTER NETWORK, WIDE-AREA COMPUTER NETWORKS, AND PEER-TO-PEER COMPUTER NETWORKS; COMPUTER SOFTWARE FOR ACCESSING INFORMATION DIRECTORIES THAT MAY BE DOWNLOADED FROM THE GLOBAL COMPUTER NETWORK; COMPUTER SOFTWARE FOR APPLICATION AND DATABASE INTEGRATION; COMPUTER SOFTWARE FOR COMMUNICATING WITH USERS OF HAND-HELD COMPUTERS; COMPUTER SOFTWARE FOR CONTROLLING AND MANAGING ACCESS SERVER APPLICATIONS; COMPUTER SOFTWARE FOR CREATING SEARCHABLE DATABASES OF INFORMATION AND DATA; COMPUTER SOFTWARE FOR PROVIDING AN ON-LINE DATABASE IN THE FIELD OF TRANSACTION PROCESSING TO UPLOAD TRANSACTIONAL DATA, PROVIDE STATISTICAL ANALYSIS, AND PRODUCE NOTIFICATIONS AND REPORTS; COMPUTER SOFTWARE FOR WIRELESS CONTENT DELIVERY; COMPUTER SOFTWARE THAT PROVIDES WEB-BASED ACCESS TO APPLICATIONS AND SERVICES THROUGH A WEB OPERATING SYSTEM OR PORTAL INTERFACE; COMPUTER SOFTWARE, NAMELY, SOFTWARE DEVELOPMENT TOOLS FOR THE CREATION OF MOBILE INTERNET APPLICATIONS AND CLIENT INTERFACES; COMPUTER TELEPHONY SOFTWARE; COMPUTER-GAMING SOFTWARE; DOWNLOADABLE AUDIO FILES, MULTIMEDIA FILES, TEXT FILES, E-MAILS, WRITTEN DOCUMENTS, AUDIO MATERIAL, VIDEO MATERIAL AND GAMES FEATURING INFORMATION IN THE FORM OF DOWNLOADABLE SHORT EDUCATIONAL/TRAINING COMMUNICATIONS IN THE FIELD OF HUMAN RESOURCE DEVELOPMENT FOR THE PROMOTION OF EMPLOYEE RETENTION, CAREER GROWTH AND INCREASED PRODUCTIVITY FOR EMPLOYEES AND EMPLOYERS; DOWNLOADABLE COMPUTER GAME SOFTWARE VIA A GLOBAL COMPUTER NETWORK AND WIRELESS DEVICES; EDUCATIONAL SOFTWARE FEATURING INSTRUCTION IN SCIENCE, TECHNOLOGY, ENGINEERING, MATHEMATICS (STEM) DISCIPLINES; ELECTRONIC EDUCATIONAL APPARATUS, NAMELY, COMMUNICATION BLOCKS THAT MANIPULATE AND CONVEY INFORMATION ELECTRONICALLY BASED ON THEIR ARRANGEMENT AND ARE USED FOR COGNITIVE DEVELOPMENT IN DISCIPLINES SUCH AS COUNTING, SPELLING OR QUANTITATIVE REASONING; ELECTRONIC GAME SOFTWARE FOR CELLULAR TELEPHONES; ELECTRONIC GAME SOFTWARE FOR WIRELESS DEVICES; GAME SOFTWARE; INTERACTIVE GAME SOFTWARE (U.S. CLS. 21, 23, 26, 36 AND 38).

FIRST USE 3-1-2010; IN COMMERCE 11-5-2010.

CLASS 9—(Continued).

4,016,598. RSR ELECTRONICS, AVENEL, NJ. SN 77-941,300. PUB. 11-23-2010, FILED 2-22-2010.

SciencePurchase

THE MARK CONSISTS OF STANDARD CHARACTERS WITHOUT CLAIM TO ANY PARTICULAR FONT, STYLE, SIZE, OR COLOR.

FOR LABORATORY EQUIPMENT AND SUPPLIES, NAMELY, INCUBATORS; LABORATORY EQUIPMENT AND SUPPLIES, NAMELY, TEST TUBES; LABORATORY EQUIPMENT, NAMELY, ELECTRIC BATH HEATERS; LABORATORY EQUIPMENT, NAMELY, FUNNELS; LABORATORY EQUIPMENT, NAMELY, PIPETTE RACKS (U.S. CLS. 21, 23, 26, 36 AND 38). FIRST USE 1-1-2010; IN COMMERCE 3-1-2010.

4,016,603. COLORADO NETWORKS, INC., COLORADO SPRINGS, CO. SN 77-943,144. PUB. 7-27-2010, FILED 2-23-2010.

eVanics

THE MARK CONSISTS OF A LOWER CASE LUCIDA HANDWRITING FONT "E" FOLLOWED WITHOUT A SPACE BY A CAPITALIZED "VANICS" IN GEORGIA FONT.

FOR COMPUTER HARDWARE AND SOFTWARE FOR SETTING UP AND CONFIGURING LOCAL AREA NETWORKS; COMPUTER HARDWARE AND SOFTWARE FOR SETTING UP AND CONFIGURING WIDE AREA NETWORKS; COMPUTER HARDWARE FOR COMMUNICATING AUDIO, VIDEO AND DATA BETWEEN COMPUTERS VIA A GLOBAL COMPUTER NETWORK, WIDE-AREA COMPUTER NETWORKS, AND PEER-TO-PEER COMPUTER NETWORKS (U.S. CLS. 21, 23, 26, 36 AND 38).

FIRST USE 6-1-2010; IN COMMERCE 6-1-2010.

CLASS 9—(Continued).

4,016,649. NEW CONCEPTS DEVELOPMENT CORPORATION, WOODSTOCK, IL. SN 77-959,788. PUB. 8-10-2010, FILED 3-16-2010.

DATA DOUBLER

THE MARK CONSISTS OF STANDARD CHARACTERS WITHOUT CLAIM TO ANY PARTICULAR FONT, STYLE, SIZE, OR COLOR.

FOR KITS FOR MOUNTING DATA STORAGE DEVICES INTO NOTEBOOK AND LAPTOP COMPUTERS, PRIMARILY COMPRISED OF CIRCUIT BOARDS AND BRACKETS (U.S. CLS. 21, 23, 26, 36 AND 38).

FIRST USE 6-22-2010; IN COMMERCE 5-13-2011.

4,016,651. GOLDEN FROG, INC., GRAND CAYMAN, CAYMAN ISLANDS. SN 77-961,731. PUB. 3-29-2011, FILED 3-17-2010.

MIMO

THE MARK CONSISTS OF STANDARD CHARACTERS WITHOUT CLAIM TO ANY PARTICULAR FONT, STYLE, SIZE, OR COLOR.

FOR DOWNLOADABLE COMPUTER SOFTWARE FOR USE IN BROWSING INFORMATION POSTED TO USENET NEWS GROUPS AND DISCUSSION GROUPS; COMPUTER SOFTWARE PLATFORMS FOR USE IN CONNECTION WITH USENET SERVICES (U.S. CLS. 21, 23, 26, 36 AND 38).

FIRST USE 7-14-2010; IN COMMERCE 7-14-2010.

4,016,662. YSI INCORPORATED, YELLOW SPRINGS, OH. SN 77-967,267. PUB. 6-29-2010, FILED 3-24-2010.

PROOBOD

THE MARK CONSISTS OF STANDARD CHARACTERS WITHOUT CLAIM TO ANY PARTICULAR FONT, STYLE, SIZE, OR COLOR.

FOR OPTICAL AND LUMINESCENT SENSORS USED IN THE MEASUREMENT OF DISSOLVED OXYGEN IN BIOCHEMICAL OXYGEN DEMAND (BOD) BOTTLES FOR BIOCHEMICAL OXYGEN DEMAND ANALYSIS (U.S. CLS. 21, 23, 26, 36 AND 38).

FIRST USE 9-30-2010; IN COMMERCE 9-30-2010.

CLASS 9—(Continued).

4,016,691. STEPHEN SHAPIRO ENTERPRISES, LLC, QUINCY, MA. SN 77-982,166. PUB. 10-6-2009, FILED 5-14-2009.

Personality Poker

THE MARK CONSISTS OF STANDARD CHARACTERS WITHOUT CLAIM TO ANY PARTICULAR FONT, STYLE, SIZE, OR COLOR.

OWNER OF U.S. REG. NO. 3,546,324.

NO CLAIM IS MADE TO THE EXCLUSIVE RIGHT TO USE "POKER", APART FROM THE MARK AS SHOWN.

FOR COMPUTER GAME SOFTWARE; DOWNLOADABLE ELECTRONIC GAMES VIA THE INTERNET AND WIRELESS DEVICES; ELECTRONIC GAME SOFTWARE; ELECTRONIC GAME SOFTWARE FOR CELLULAR TELEPHONES; ELECTRONIC GAME SOFTWARE FOR HANDHELD ELECTRONIC DEVICES; ELECTRONIC GAME SOFTWARE FOR WIRELESS DEVICES; VIDEO GAME SOFTWARE (U.S. CLS. 21, 23, 26, 36 AND 38).
FIRST USE 8-1-2010; IN COMMERCE 8-1-2010.

CLASS 9—(Continued).

4,016,697. GEFION RECORDS APS, DK-2830 VIRUM, DENMARK. SN 77-982,198. PUB. 9-14-2010, FILED 9-10-2009.

MUSICURE MUSIC AS MEDICINE

THE MARK CONSISTS OF STANDARD CHARACTERS WITHOUT CLAIM TO ANY PARTICULAR FONT, STYLE, SIZE, OR COLOR.

FOR CDS AND DVDS CONTAINING SPECIFICALLY COMPOSED AND PRODUCED MUSIC AND SOUND LANDSCAPES WITH NATURE SOUNDS, AS WELL AS CDS AND DVDS WHICH CONTAIN SUCH MUSIC TOGETHER WITH PICTURES, ALL FOR THERAPEUTIC USE BY HOSPITALS, CLINICS, AND HEALTHCARE-RELATED INSTITUTIONS (U.S. CLS. 21, 23, 26, 36 AND 38).

FIRST USE 7-28-2005; IN COMMERCE 7-28-2005.

4,016,693. G-III LEATHER FASHIONS, INC., NEW YORK, NY. SN 77-982,169. PUB. 4-27-2010, FILED 7-10-2009.

MARC NEW YORK ANDREW MARC

THE MARK CONSISTS OF STANDARD CHARACTERS WITHOUT CLAIM TO ANY PARTICULAR FONT, STYLE, SIZE, OR COLOR.

OWNER OF U.S. REG. NOS. 1,221,846, 3,464,631, AND OTHERS.

NO CLAIM IS MADE TO THE EXCLUSIVE RIGHT TO USE "NEW YORK", APART FROM THE MARK AS SHOWN.

THE NAME(S), PORTRAIT(S), AND/OR SIGNATURE(S) SHOWN IN THE MARK IDENTIFIES "ANDREW MARC", WHOSE CONSENT(S) TO REGISTER IS MADE OF RECORD.

FOR EYEWEAR; SUNGLASSES; BRIEFCASES SPECIALLY ADAPTED FOR HOLDING LAPTOP COMPUTERS; BACKPACKS ESPECIALLY ADAPTED FOR HOLDING LAPTOPS (U.S. CLS. 21, 23, 26, 36 AND 38).
FIRST USE 2-0-2011; IN COMMERCE 2-0-2011.

4,016,719. TWENTIETH CENTURY FOX FILM CORPORATION, LOS ANGELES, CA. SN 78-850,696. PUB. 5-10-2011, FILED 3-30-2006.

FOX ATOMIC

THE MARK CONSISTS OF STANDARD CHARACTERS WITHOUT CLAIM TO ANY PARTICULAR FONT, STYLE, SIZE, OR COLOR.

OWNER OF U.S. REG. NOS. 2,266,767, 3,094,321, AND OTHERS.

FOR MOTION PICTURE FILMS FEATURING ACTION, ADVENTURE, DRAMA, COMEDY, MUSIC, CULTURE, LIFESTYLE; PRE-RECORDED DVDS FEATURING ACTION, ADVENTURE; DRAMA, COMEDY, MUSIC, CULTURE, LIFESTYLE; DOWNLOADABLE MOTION PICTURES FEATURING ACTION, ADVENTURE, DRAMA, COMEDY, MUSIC, CULTURE, LIFESTYLE (U.S. CLS. 21, 23, 26, 36 AND 38).
FIRST USE 12-1-2006; IN COMMERCE 12-1-2006.

CLASS 9—(Continued).

4,016,735. KABUSHIKI KAISHA SQUARE ENIX HOLDINGS, TA SQUARE ENIX HOLDINGS CO., LTD., TOKYO, JAPAN. SN 85-005,947. PUB. 12-14-2010, FILED 4-5-2010.



PRIORITY CLAIMED UNDER SEC. 44(D) ON JAPAN APPLICATION NO. 2010-024983, FILED 3-31-2010, REG. NO. 5361624, DATED 10-15-2010, EXPIRES 10-15-2020.

OWNER OF U.S. REG. NO. 3,490,097.
THE COLOR(S) BLACK, WHITE AND RED IS/ARE CLAIMED AS A FEATURE OF THE MARK.

THE MARK CONSISTS OF A STYLIZED LETTER "E" ON A BLACK SQUARED BACKGROUND WITH CURVED CORNERS. THE OUTER ELEMENT OF THE LETTER "E" IS WHITE AND THE MIDDLE HORIZONTAL BAR IS RED.

FOR (BASED ON 44(E)) SOUND RECORDINGS IN THE FORM OF OPTICAL DISCS, MAGNETIC DISCS AND SEMICONDUCTOR ROMS FEATURING MUSIC AND FICTIONAL STORIES; AUDIO VISUAL RECORDINGS IN THE FORM OF OPTICAL DISCS, MAGNETIC DISCS AND SEMICONDUCTOR ROMS FEATURING MUSIC AND ANIMATED FICTIONAL STORIES; PRE-RECORDED COMPACT DISCS FEATURING MUSIC; PRERECORDED VIDEO DISCS FEATURING MUSIC AND ANIMATED FICTIONAL STORIES; STRAPS FOR CELLULAR PHONES; VIDEO GAME CONTROLLERS; DOWNLOADABLE MUSICAL SOUND RECORDINGS; DOWNLOADABLE RING TONES FOR MOBILE PHONES; DOWNLOADABLE ELECTRONIC PUBLICATIONS IN THE NATURE OF MAGAZINES, JOURNALS AND NEWSLETTERS IN THE FIELD OF COMPUTER GAMES AND VIDEO GAMES; (BASED ON USE AND 44(E)) COMPUTER GAME SOFTWARE; VIDEO GAME SOFTWARE; DOWNLOADABLE WALLPAPER GRAPHICS FOR MOBILE PHONES (U.S. CLS. 21, 23, 26, 36 AND 38).

FIRST USE 5-13-2009; IN COMMERCE 5-13-2009.

4,016,739. BEYONDTRUST SOFTWARE, INC., AGOURA HILLS, CA. SN 85-007,895. PUB. 9-21-2010, FILED 4-6-2010.

PASSWORD SAFE

THE MARK CONSISTS OF STANDARD CHARACTERS WITHOUT CLAIM TO ANY PARTICULAR FONT, STYLE, SIZE, OR COLOR.

CLASS 9—(Continued).

NO CLAIM IS MADE TO THE EXCLUSIVE RIGHT TO USE "PASSWORD", APART FROM THE MARK AS SHOWN.
FOR COMPUTER HARDWARE AND SOFTWARE PROGRAMS TO ASSIST IN PASSWORD MANAGEMENT AND SECURITY (U.S. CLS. 21, 23, 26, 36 AND 38).
FIRST USE 5-0-2010; IN COMMERCE 5-0-2010.

4,016,740. BEYONDTRUST SOFTWARE, INC., AGOURA HILLS, CA. SN 85-007,896. PUB. 9-21-2010, FILED 4-6-2010.



OWNER OF U.S. REG. NOS. 2,139,979 AND 3,435,338.
NO CLAIM IS MADE TO THE EXCLUSIVE RIGHT TO USE "PASSWORD", APART FROM THE MARK AS SHOWN.

THE MARK CONSISTS OF A STYLISTIC DESIGN OF THE LETTER "Q" CONTAINING STRIPES AS ACCENTS WITH AN INVERTED TRIANGLE IN ITS CENTER AND THE WORDS "POWERBROKER PASSWORD SAFE" LOCATED TO THE RIGHT OF THE DESIGN WITH THE WORD "PASSWORD" LOCATED ON TOP OF THE WORD "SAFE".

FOR COMPUTER HARDWARE AND SOFTWARE PROGRAMS TO ASSIST IN PASSWORD MANAGEMENT AND SECURITY (U.S. CLS. 21, 23, 26, 36 AND 38).
FIRST USE 5-0-2010; IN COMMERCE 5-0-2010.

4,016,741. BEYONDTRUST SOFTWARE, INC., AGOURA HILLS, CA. SN 85-007,898. PUB. 4-5-2011, FILED 4-6-2010.

**POWERBROKER MANAGEMENT
CONSOLE**

THE MARK CONSISTS OF STANDARD CHARACTERS WITHOUT CLAIM TO ANY PARTICULAR FONT, STYLE, SIZE, OR COLOR.

OWNER OF U.S. REG. NOS. 2,139,979 AND 3,435,338.
NO CLAIM IS MADE TO THE EXCLUSIVE RIGHT TO USE "MANAGEMENT CONSOLE", APART FROM THE MARK AS SHOWN.

FOR COMPUTER SOFTWARE PROGRAMS FOR THE CENTRALIZED MANAGEMENT AND REPORTING OF POLICY MANAGEMENT IN THE FIELD(S) OF INFORMATION TECHNOLOGY, SECURITY AND IDENTITY MANAGEMENT (U.S. CLS. 21, 23, 26, 36 AND 38).
FIRST USE 5-0-2010; IN COMMERCE 5-0-2010.

CLASS 9—(Continued).

4,016,742. BEYONDTRUST SOFTWARE, INC., AGOURA HILLS, CA. SN 85-007,899. PUB. 4-5-2011, FILED 4-6-2010.



OWNER OF U.S. REG. NOS. 2,139,979 AND 3,435,338.
NO CLAIM IS MADE TO THE EXCLUSIVE RIGHT TO USE "MANAGEMENT CONSOLE", APART FROM THE MARK AS SHOWN.

THE MARK CONSISTS OF A STYLISTIC DESIGN OF AN INVERTED LETTER "Q" CONTAINING STRIPES AS ACCENTS WITH AN INVERTED TRIANGLE IN ITS CENTER AND THE WORDS "POWERBROKER MANAGEMENT CONSOLE" LOCATED TO THE LEFT OF THE DESIGN.

FOR COMPUTER SOFTWARE PROGRAMS FOR THE CENTRALIZED MANAGEMENT AND REPORTING OF POLICY MANAGEMENT IN THE FIELD(S) OF INFORMATION TECHNOLOGY, SECURITY AND IDENTITY MANAGEMENT (U.S. CLS. 21, 23, 26, 36 AND 38).
FIRST USE 5-0-2010; IN COMMERCE 5-0-2010.

4,016,744. BEYONDTRUST SOFTWARE, INC., AGOURA HILLS, CA. SN 85-008,235. PUB. 3-29-2011, FILED 4-7-2010.



OWNER OF U.S. REG. NOS. 2,139,979 AND 3,435,338.
NO CLAIM IS MADE TO THE EXCLUSIVE RIGHT TO USE "DIRECTORY INTEGRATOR", APART FROM THE MARK AS SHOWN.

THE MARK CONSISTS OF A STYLISTIC DESIGN OF AN INVERTED LETTER "Q" CONTAINING STRIPES AS ACCENTS WITH AN INVERTED TRIANGLE IN ITS CENTER AND THE WORDS "POWERBROKER DIRECTORY INTEGRATOR" LOCATED TO THE LEFT OF THE DESIGN.

FOR COMPUTER SOFTWARE PROGRAMS THAT PROVIDE ACCESS TO MULTIPLE APPLICATIONS IN DIFFERENT OPERATING SYSTEMS (U.S. CLS. 21, 23, 26, 36 AND 38).
FIRST USE 6-8-2010; IN COMMERCE 6-8-2010.

CLASS 9—(Continued).

4,016,754. QUANTIA COMMUNICATIONS, INC., WALTHAM, MA. SN 85-013,829. PUB. 1-11-2011, FILED 4-14-2010.

QUANTIACARE

THE MARK CONSISTS OF STANDARD CHARACTERS WITHOUT CLAIM TO ANY PARTICULAR FONT, STYLE, SIZE, OR COLOR.

OWNER OF U.S. REG. NO. 3,293,127.

FOR DOWNLOADABLE COMPUTER SOFTWARE FOR ALLOWING PATIENTS TO SECURELY RECORD HEALTH-RELATED DATA AND INTERACT WITH PHYSICIANS (U.S. CLS. 21, 23, 26, 36 AND 38).

FIRST USE 12-17-2010; IN COMMERCE 12-17-2010.

4,016,773. BURMER, GLENNA C., SEATTLE, WA. SN 85-023,598. PUB. 9-28-2010, FILED 4-26-2010.

GLENNA

THE MARK CONSISTS OF STANDARD CHARACTERS WITHOUT CLAIM TO ANY PARTICULAR FONT, STYLE, SIZE, OR COLOR.

THE NAME "GLENNA" IDENTIFIES A LIVING INDIVIDUAL WHOSE CONSENT IS OF RECORD.

FOR COMPACT DISCS FEATURING MUSIC; DIGITAL MUSIC DOWNLOADABLE FROM THE INTERNET; DOWNLOADABLE MP3 FILES, MP3 RECORDINGS, ONLINE DISCUSSION BOARDS, WEBCASTS, WEBINARS AND PODCASTS FEATURING MUSIC, AUDIO BOOKS AND NEWS BROADCASTS; DOWNLOADABLE MUSIC VIA THE INTERNET AND WIRELESS DEVICES (U.S. CLS. 21, 23, 26, 36 AND 38).

FIRST USE 8-11-2010; IN COMMERCE 8-11-2010.

4,016,775. SCHULTZ, DOUGLAS JAMES, OAKLAND PARK, FL. SN 85-025,549. PUB. 9-14-2010, FILED 4-28-2010.



THE COLOR(S) RED, WHITE, AND GRAY IS/ARE CLAIMED AS A FEATURE OF THE MARK.

CLASS 9—(Continued).

THE MARK CONSISTS OF THE WORDING "HUMAN BOBBER HOW DO YOU BOB?" THE WORDS "HUMAN" AND "HOW DO YOU BOB?" ARE SHOWN IN THE COLOR WHITE. THE WORD "BOBBER" IS SHOWN IN THE COLOR GRAY WITH THE LETTER "O" IN BOBBER IS COMPRISED OF A DESIGN OF A FISHING BOBBER IN THE COLORS WHITE AND RED.

FOR LIFE BELTS; LIFE PRESERVERS; LIFE VESTS; LIFEJACKETS (U.S. CLS. 21, 23, 26, 36 AND 38).
FIRST USE 6-1-2011; IN COMMERCE 6-1-2011.

4,016,776. SCHULTZ, DOUGLAS JAMES, OAKLAND PARK, FL. SN 85-025,656. PUB. 11-16-2010, FILED 4-28-2010.



NO CLAIM IS MADE TO THE EXCLUSIVE RIGHT TO USE "SPORTS", APART FROM THE MARK AS SHOWN.

THE COLOR(S) BLUE, BLACK, WHITE AND GREY IS/ ARE CLAIMED AS A FEATURE OF THE MARK.

THE MARK CONSISTS OF THE WORDS "H3O SPORTS". THE LETTERS "H" AND "O" ARE GREY OUTLINED IN BLUE. THE NUMBER "3" IS WHITE OUTLINED IN BLUE. THE WORD "SPORTS" IS BLUE UNDER THE LETTER "O". THE PHRASE "THE NEXT DIMENSION IN SPORTS" IS WRITTEN UNDERNEATH IN BLUE. THERE ARE TWO BLUE WAVES DIRECTLY ABOVE THE "H3O".

FOR LIFE BELTS; LIFE JACKETS; LIFE NETS; LIFE PRESERVERS; LIFE SAVING RAFTS; LIFE VESTS; LIFE-SAVING RAFTS; LIFEJACKETS (U.S. CLS. 21, 23, 26, 36 AND 38).

FIRST USE 6-1-2011; IN COMMERCE 6-1-2011.

4,016,779. TERRELL, IVANNA SAMAL, LEWISVILLE, TX. SN 85-025,945. PUB. 9-28-2010, FILED 4-29-2010.

Lastaria

THE MARK CONSISTS OF STANDARD CHARACTERS WITHOUT CLAIM TO ANY PARTICULAR FONT, STYLE, SIZE, OR COLOR.

FOR DIGITAL MUSIC DOWNLOADABLE FROM THE INTERNET; DOWNLOADABLE MUSICAL SOUND RECORDINGS (U.S. CLS. 21, 23, 26, 36 AND 38).
FIRST USE 3-7-2011; IN COMMERCE 3-7-2011.

CLASS 9—(Continued).

4,016,795. BOUGHT INCORPORATED, BRYN ATHYN, PA. SN 85-034,390. PUB. 10-12-2010, FILED 5-10-2010.

BOUGHT

THE MARK CONSISTS OF STANDARD CHARACTERS WITHOUT CLAIM TO ANY PARTICULAR FONT, STYLE, SIZE, OR COLOR.

FOR EYEWEAR, NAMELY, SUNGLASSES, EYEGLASSES, SPECTACLES; FRAMES, LENSES AND CASES FOR EYEGLASSES AND SUNGLASSES; PRESCRIPTION EYEWEAR; PROTECTIVE EYEWEAR (U.S. CLS. 21, 23, 26, 36 AND 38).

FIRST USE 6-1-2011; IN COMMERCE 6-1-2011.

4,016,796. BOUGHT INCORPORATED, BRYN ATHYN, PA. SN 85-034,416. PUB. 10-12-2010, FILED 5-10-2010.

BOUGHT SUNGLASSES

THE MARK CONSISTS OF STANDARD CHARACTERS WITHOUT CLAIM TO ANY PARTICULAR FONT, STYLE, SIZE, OR COLOR.

NO CLAIM IS MADE TO THE EXCLUSIVE RIGHT TO USE "SUNGLASSES", APART FROM THE MARK AS SHOWN.

FOR EYEWEAR, NAMELY, SUNGLASSES, EYEGLASSES, SPECTACLES; FRAMES, LENSES AND CASES FOR EYEGLASSES AND SUNGLASSES; PRESCRIPTION EYEWEAR; PROTECTIVE EYEWEAR (U.S. CLS. 21, 23, 26, 36 AND 38).

FIRST USE 6-1-2011; IN COMMERCE 6-1-2011.

CLASS 9—(Continued).

4,016,801. **HARDCANDY CASES, LLC, DANVILLE, CA.** SN 85-035,829. PUB. 11-2-2010, FILED 5-11-2010.

GumDrop

THE MARK CONSISTS OF STANDARD CHARACTERS WITHOUT CLAIM TO ANY PARTICULAR FONT, STYLE, SIZE, OR COLOR.

FOR PROTECTIVE CASES, FITTED PLASTIC FILMS KNOWN AS SKINS FOR COVERING AND PROVIDING A SCRATCH-PROOF BARRIER, AND COVERS FOR LAPTOP COMPUTERS, NOTEBOOK COMPUTERS, SMARTPHONES, CELLULAR PHONES, HANDHELD MOBILE DIGITAL ELECTRONIC DEVICES, PORTABLE AND HANDHELD DIGITAL ELECTRONIC DEVICES, MP3 PLAYERS, PERSONAL DIGITAL ASSISTANTS, AND ELECTRONIC AND DIGITAL HANDHELD CONSUMER DEVICES (U.S. CLS. 21, 23, 26, 36 AND 38).
FIRST USE 5-0-2010; IN COMMERCE 5-0-2010.

4,016,823. **T. RICHARD TRAMMELL, GAFFNEY, SC.** SN 85-042,878. PUB. 10-26-2010, FILED 5-19-2010.

TERRY PAK

THE MARK CONSISTS OF STANDARD CHARACTERS WITHOUT CLAIM TO ANY PARTICULAR FONT, STYLE, SIZE, OR COLOR.

NO CLAIM IS MADE TO THE EXCLUSIVE RIGHT TO USE "PAK", APART FROM THE MARK AS SHOWN.

FOR COMPACT DISC CASES; DVD CASES; HOLDERS FOR COMPACT DISCS (U.S. CLS. 21, 23, 26, 36 AND 38).
FIRST USE 6-1-2011; IN COMMERCE 6-1-2011.

4,016,824. **AGRIUM INC., CALGARY, ALBERTA, CANADA.** SN 85-043,132. PUB. 10-19-2010, FILED 5-19-2010.

NUTRI-GRAPH

THE MARK CONSISTS OF STANDARD CHARACTERS WITHOUT CLAIM TO ANY PARTICULAR FONT, STYLE, SIZE, OR COLOR.

FOR COMPUTER SOFTWARE FOR MODELING THE NITROGEN RELEASE OF FERTILIZERS (U.S. CLS. 21, 23, 26, 36 AND 38).
FIRST USE 5-0-2010; IN COMMERCE 5-22-2010.

CLASS 9—(Continued).

4,016,858. **QRP, INCORPORATED, TUCSON, AZ.** SN 85-052,646. PUB. 11-9-2010, FILED 6-2-2010.

LITTLE RED GRIPPER

THE MARK CONSISTS OF STANDARD CHARACTERS WITHOUT CLAIM TO ANY PARTICULAR FONT, STYLE, SIZE, OR COLOR.

NO CLAIM IS MADE TO THE EXCLUSIVE RIGHT TO USE "RED", APART FROM THE MARK AS SHOWN.

FOR PROTECTIVE WORK GLOVES (U.S. CLS. 21, 23, 26, 36 AND 38).
FIRST USE 8-1-2010; IN COMMERCE 8-1-2010.

4,016,862. **TECH LOGIC CORPORATION, WHITE BEAR LAKE, MN.** SN 85-053,639. PUB. 3-22-2011, FILED 6-3-2010.



THE COLOR(S) RED, BLUE IS/ARE CLAIMED AS A FEATURE OF THE MARK.

THE MARK CONSISTS OF THE RED WORDING "UTAG" AND TWO BLUE INCOMPLETE CONCENTRIC CIRCLES WITH THE BLUE WORDING "IT" EMBEDDED IN THE CIRCLES. THE COLOR WHITE REPRESENTS THE BACKGROUND AND IS NOT PART OF THE MARK.

FOR PORTABLE ELECTRONIC MINI-TAGGING STATION COMPRISING SOFTWARE AND HARDWARE FOR CONVERTING BARCODE TO RFID (RADIO FREQUENCY IDENTIFICATION) TAGS FOR USE IN LIBRARIES (U.S. CLS. 21, 23, 26, 36 AND 38).

FIRST USE 8-1-2010; IN COMMERCE 8-1-2010.

CLASS 9—(Continued).

4,016,898. TERRELL, IVANNA SAMAL, DBA LASTARIA, LEWISVILLE, TX. SN 85-063,202. PUB. 10-5-2010, FILED 6-15-2010.



THE COLOR(S) BLUE, WHITE AND SILVER IS/ARE CLAIMED AS A FEATURE OF THE MARK.

THE MARK CONSISTS OF "LASTARIA" WRITTEN IN BLUE WITH THE "I" DOTTED WITH A LARGE BLUE STAR. "LASTARIA" IS ACCENTED WITH SILVER AND WHITE SHADOW AND LIGHT EFFECTS. MULTIPLE SILVER AND BLUE STARS WITH SILVER AND WHITE SHADOW EFFECTS SURROUND THE WORD "LASTARIA".

FOR DIGITAL MUSIC DOWNLOADABLE FROM THE INTERNET; DOWNLOADABLE MP3 FILES, MP3 RECORDINGS, ON-LINE DISCUSSION BOARDS, WEBCASTS, WEBINARS AND PODCASTS FEATURING MUSIC, AUDIO BOOKS AND NEWS BROADCASTS; DOWNLOADABLE MUSICAL SOUND RECORDINGS (U.S. CLS. 21, 23, 26, 36 AND 38).

FIRST USE 3-7-2011; IN COMMERCE 3-7-2011.

4,016,914. VANI U.S.A., INC., NEW YORK, NY. SN 85-066,419. PUB. 12-7-2010, FILED 6-18-2010.



OWNER OF U.S. REG. NO. 3,694,079.

CLASS 9—(Continued).

THE MARK CONSISTS OF LETTERS "AG" IN STYLIZED FORM.

FOR EYEWEAR, NAMELY, EYEGLASSES, SUNGLASSES, OPTICAL GLASSES, MAGNIFYING GLASSES, CONTACT LENSES; EYEWEAR ACCESSORIES, STRAPS, NECK CORDS, HEAD STRAPS, EYEWEAR CASES, CASES FOR SPECTACLES AND CONTACT LENSES, NOSE GUARDS, EYEGLOSS CHAINS, EYEGLOSS FRAMES, EYEGLOSS LENSES, MAGNIFYING LENSES, OPTICAL FRAMES, SUNGLASSES LENSES, OPTICAL LENSES; EYEWEAR RETAINERS; PROTECTIVE EYEWEAR AND COMPONENT PARTS THEREOF (U.S. CLS. 21, 23, 26, 36 AND 38).

FIRST USE 2-18-2002; IN COMMERCE 3-18-2008.

4,016,942. THALES E-SECURITY LIMITED, ADDLESTONE, WEYBRIDGE, UNITED KINGDOM. SN 85-071,281. PUB. 3-15-2011, FILED 6-24-2010.

NCIPHER

THE MARK CONSISTS OF STANDARD CHARACTERS WITHOUT CLAIM TO ANY PARTICULAR FONT, STYLE, SIZE, OR COLOR.

OWNER OF U.S. REG. NO. 2,551,925.

FOR COMPUTER HARDWARE, COMPUTER PERIPHERAL DEVICES INCLUDING ACCELERATORS AND ENCRYPTOGRAPHIC ACCELERATORS FOR DATA SECURITY AND FOR USE WITH COMPUTER SOFTWARE; PARTS AND FITTINGS FOR ALL THE AFORESAID GOODS; COMPUTER SOFTWARE, ENCODED COMPUTER PROGRAMS AND FIRMWARE FOR ENCRYPTION (U.S. CLS. 21, 23, 26, 36 AND 38).

FIRST USE 12-19-1997; IN COMMERCE 12-19-1997.

4,016,943. ZHONGSHAN VBO HARDWARE & ELECTRICAL EQUIPMENT CO., LTD., GUANGDONG PROVINCE, CHINA. SN 85-071,332. PUB. 11-23-2010, FILED 6-25-2010.



THE MARK CONSISTS OF THE WORD "TAC" WITH THE TOP HORIZONTAL LINE OF THE CHARACTER "T" LENGTHENED, THE WORD "JNC" ABOVE THE HORIZONTAL LINE, BOTH INSIDE AN OVAL.

THE WORDING "JNC TAC" HAS NO MEANING IN A FOREIGN LANGUAGE.

FOR AMPLIFIERS; AUDIO SPEAKERS; DVD PLAYERS; LOUDSPEAKERS; MICROPHONES; MICROPHONES FOR COMMUNICATION DEVICES; RADIOS (U.S. CLS. 21, 23, 26, 36 AND 38).

FIRST USE 2-10-2003; IN COMMERCE 3-15-2011.

CLASS 9—(Continued).

4,016,949. MICROWORLD TECHNOLOGIES, INC., FARMINGTON HILLS, MI. SN 85-073,438. PUB. 11-30-2010, FILED 6-29-2010.

ESCANAV

THE MARK CONSISTS OF STANDARD CHARACTERS WITHOUT CLAIM TO ANY PARTICULAR FONT, STYLE, SIZE, OR COLOR.

FOR COMPUTER ANTI-VIRUS SOFTWARE; ANTI-SPYWARE SOFTWARE; COMPUTER SOFTWARE TO DISTINGUISH BETWEEN SOLICITED AND UNSOLICITED ELECTRONIC MAIL MESSAGES; COMPUTER SOFTWARE FOR THE CREATION OF FIREWALLS; COMPUTER SECURITY SOFTWARE; PRIVACY PROTECTION SOFTWARE (U.S. CLS. 21, 23, 26, 36 AND 38).
FIRST USE 6-24-2011; IN COMMERCE 6-24-2011.

4,016,955. SUMMER INFANT (USA), INC., WOONSOCKET, RI. SN 85-075,356. PUB. 11-23-2010, FILED 6-30-2010.

Baby Touch

THE MARK CONSISTS OF STANDARD CHARACTERS WITHOUT CLAIM TO ANY PARTICULAR FONT, STYLE, SIZE, OR COLOR.

NO CLAIM IS MADE TO THE EXCLUSIVE RIGHT TO USE "BABY", APART FROM THE MARK AS SHOWN.

FOR BABY MONITORS (U.S. CLS. 21, 23, 26, 36 AND 38).
FIRST USE 9-2-2010; IN COMMERCE 9-0-2010.

4,016,958. SUMMER INFANT (USA), INC., WOONSOCKET, RI. SN 85-075,832. PUB. 11-23-2010, FILED 7-1-2010.

Baby Moments

THE MARK CONSISTS OF STANDARD CHARACTERS WITHOUT CLAIM TO ANY PARTICULAR FONT, STYLE, SIZE, OR COLOR.

NO CLAIM IS MADE TO THE EXCLUSIVE RIGHT TO USE "BABY", APART FROM THE MARK AS SHOWN.

FOR BABY MONITORS (U.S. CLS. 21, 23, 26, 36 AND 38).
FIRST USE 4-0-2011; IN COMMERCE 4-0-2011.

CLASS 9—(Continued).

4,016,959. C D LISTENING BAR, INC., DBA SUPER D, IRVINE, CA. SN 85-076,212. PUB. 2-1-2011, FILED 7-1-2010.



THE COLOR(S) RED, WHITE, PINK AND BLACK IS/ARE CLAIMED AS A FEATURE OF THE MARK.

THE MARK CONSISTS OF THE WORD "TARTARE" IN WHICH THE FIRST "T" IS REPRESENTED BY A T-BONE STEAK IN THE COLORS RED, WHITE AND PINK, AND OUTLINED IN BLACK; THE LETTERS "A"- "R"- "T"- "A"- "R"- "E" ARE IN LOWERCASE STYLIZED BLACK FONT.

FOR AUDIO AND VIDEO RECORDINGS FEATURING MUSIC AND ARTISTIC PERFORMANCES; DIGITAL MEDIA, NAMELY, PRE-RECORDED VIDEO CASSETTES, DIGITAL VIDEO DISCS, DIGITAL VERSATILE DISCS, DOWNLOADABLE AUDIO AND VIDEO RECORDINGS, DVDS, AND HIGH DEFINITION DIGITAL DISCS FEATURING CLASSIC AND COLLECTIBLE RECORDING ARTISTS; MUSICAL SOUND RECORDINGS; MUSICAL VIDEO RECORDINGS; PRE-RECORDED CDS FEATURING CLASSIC AND COLLECTIBLE RECORDING ARTISTS; PRE-RECORDED DVDS FEATURING CLASSIC AND COLLECTIBLE RECORDING ARTISTS; PRE-RECORDED ELECTRONIC AND DIGITAL MEDIA FEATURING CLASSIC AND COLLECTIBLE RECORDING ARTISTS (U.S. CLS. 21, 23, 26, 36 AND 38).
FIRST USE 7-21-2010; IN COMMERCE 7-21-2010.

4,016,976. ADVANCE MAGAZINE PUBLISHERS INC., NEW YORK, NY. SN 85-081,106. PUB. 11-30-2010, FILED 7-9-2010.

ALLURE

THE MARK CONSISTS OF STANDARD CHARACTERS WITHOUT CLAIM TO ANY PARTICULAR FONT, STYLE, SIZE, OR COLOR.

OWNER OF U.S. REG. NOS. 1,378,072, 1,751,878, AND OTHERS.

FOR DOWNLOADABLE SOFTWARE APPLICATION FEATURING BEAUTY AND FASHION INFORMATION FOR USE IN CONNECTION WITH SMART PHONES, PDA DEVICES, TABLET COMPUTERS AND OTHER PORTABLE AND HANDHELD DIGITAL ELECTRONIC DEVICES (U.S. CLS. 21, 23, 26, 36 AND 38).

FIRST USE 4-12-2011; IN COMMERCE 4-12-2011.

CLASS 9—(Continued).

4,016,980. PANTECH CO., LTD., MAPO-GU, SEOUL, REPUBLIC OF KOREA. SN 85-082,373. PUB. 3-8-2011, FILED 7-12-2010.

Pantech Laser

THE MARK CONSISTS OF STANDARD CHARACTERS WITHOUT CLAIM TO ANY PARTICULAR FONT, STYLE, SIZE, OR COLOR.

OWNER OF U.S. REG. NOS. 3,036,436 AND 3,463,343.
FOR BATTERIES; BATTERY CHARGERS; CELLULAR TELEPHONES; COMPUTER PROGRAMS FOR USE IN DATA COMMUNICATION BETWEEN MOBILE TELEPHONES AND COMPUTERS; EARPHONES; HEADPHONES; MOBILE TELEPHONE BATTERIES; MOBILE TELEPHONES; RECHARGEABLE ELECTRIC BATTERIES; SATELLITE NAVIGATIONAL SYSTEM, NAMELY, A GLOBAL POSITIONING SYSTEM (GPS) (U.S. CLS. 21, 23, 26, 36 AND 38).
FIRST USE 10-17-2010; IN COMMERCE 10-17-2010.

4,016,983. BICOM, INC., DBA ZÖET, MONROE, CT. SN 85-082,461. PUB. 12-14-2010, FILED 7-12-2010.

zöet

THE MARK CONSISTS OF STANDARD CHARACTERS WITHOUT CLAIM TO ANY PARTICULAR FONT, STYLE, SIZE, OR COLOR.

THE ENGLISH TRANSLATION OF THE WORD "ZÖET" IN THE MARK IS SWEET.

FOR COMPUTER HARDWARE FOR COMMUNICATING AUDIO, VIDEO AND DATA BETWEEN COMPUTERS VIA A GLOBAL COMPUTER NETWORK, WIDE-AREA COMPUTER NETWORKS, AND PEER-TO-PEER COMPUTER NETWORKS; CONSUMER ELECTRONIC PRODUCTS, NAMELY, AUDIO AMPLIFIERS, AUDIO SPEAKERS, AUDIO RECEIVERS, ELECTRICAL AUDIO AND SPEAKER CABLES AND CONNECTORS, HOME THEATER SYSTEMS, AUDIO DECODERS, VIDEO DECODERS, SPEAKERS, POWER CONVERSION DEVICES, POWER CONVERTERS, AND POWER INVERTERS; HOME THEATER SYSTEMS COMPRISING NETWORKED AUDIO/VIDEO RECEIVERS AND NETWORKED AMPLIFIERS AND SPEAKERS (U.S. CLS. 21, 23, 26, 36 AND 38).
FIRST USE 7-28-2008; IN COMMERCE 4-15-2011.

CLASS 9—(Continued).

4,017,024. 24 HOUR FITNESS USA, INC., SAN RAMON, CA. SN 85-093,185. PUB. 12-7-2010, FILED 7-26-2010.

BODYBUGGSP

THE MARK CONSISTS OF STANDARD CHARACTERS WITHOUT CLAIM TO ANY PARTICULAR FONT, STYLE, SIZE, OR COLOR.

OWNER OF U.S. REG. NOS. 3,230,870 AND 3,276,479.
FOR COMPUTER SOFTWARE, NAMELY, SOFTWARE USED ON HANDHELD MOBILE AND WEARABLE ELECTRONIC DEVICES FOR DETECTING, STORING AND REPORTING HUMAN PHYSIOLOGICAL AND ENVIRONMENTAL PARAMETERS (U.S. CLS. 21, 23, 26, 36 AND 38).
FIRST USE 10-0-2010; IN COMMERCE 10-0-2010.

4,017,031. MOTOROLA TRADEMARK HOLDINGS, LLC, LIBERTYVILLE, IL. SN 85-096,153. PUB. 12-7-2010, FILED 7-29-2010.

MOTOROLA DEFY

THE MARK CONSISTS OF STANDARD CHARACTERS WITHOUT CLAIM TO ANY PARTICULAR FONT, STYLE, SIZE, OR COLOR.

OWNER OF U.S. REG. NOS. 1,671,037, 2,349,586, AND OTHERS.

FOR CELLULAR PHONES (U.S. CLS. 21, 23, 26, 36 AND 38).
FIRST USE 10-24-2010; IN COMMERCE 10-24-2010.

4,017,045. AMPHENOL CORPORATION, WALLINGFORD, CT. SN 85-102,008. PUB. 4-12-2011, FILED 8-6-2010.

InfinX

THE MARK CONSISTS OF STANDARD CHARACTERS WITHOUT CLAIM TO ANY PARTICULAR FONT, STYLE, SIZE, OR COLOR.

FOR ELECTRICAL CONNECTORS (U.S. CLS. 21, 23, 26, 36 AND 38).
FIRST USE 6-16-2011; IN COMMERCE 6-16-2011.

CLASS 9—(Continued).

4,017,082. TEAM PLAY, INC., ELK GROVE VILLAGE, IL. SN 85-112,889. PUB. 2-8-2011, FILED 8-21-2010.

FUN STOP PHOTOS

THE MARK CONSISTS OF STANDARD CHARACTERS WITHOUT CLAIM TO ANY PARTICULAR FONT, STYLE, SIZE, OR COLOR.

NO CLAIM IS MADE TO THE EXCLUSIVE RIGHT TO USE "PHOTOS", APART FROM THE MARK AS SHOWN.

FOR COIN, BILL AND CARD OPERATED PHOTO BOOTHS WHICH TAKE PHOTOGRAPHS AND ALLOW THE USER TO RECEIVE PHOTOGRAPHS (U.S. CLS. 21, 23, 26, 36 AND 38).

FIRST USE 12-27-2010; IN COMMERCE 12-27-2010.

CLASS 9—(Continued).

4,017,103. PONY, INC., LOS ANGELES, CA. SN 85-123,781. PUB. 11-23-2010, FILED 9-7-2010.

PONY

THE MARK CONSISTS OF STANDARD CHARACTERS WITHOUT CLAIM TO ANY PARTICULAR FONT, STYLE, SIZE, OR COLOR.

OWNER OF U.S. REG. NOS. 2,666,380, 3,687,538, AND OTHERS.

FOR EYEWEAR PRODUCTS, NAMELY, EYEGLASSES, SUNGLASSES AND FRAMES AND REPLACEMENT PARTS THEREFOR; EYEWEAR ACCESSORIES, NAMELY, EYEGGLASS HOLDERS, CASES AND POUCHES (U.S. CLS. 21, 23, 26, 36 AND 38). FIRST USE 7-1-2010; IN COMMERCE 7-1-2010.

4,017,098. BEYOND CATEGORY LLC, NEW YORK, NY. SN 85-119,937. PUB. 1-25-2011, FILED 8-31-2010.

RUN SPECTRUM

THE MARK CONSISTS OF STANDARD CHARACTERS WITHOUT CLAIM TO ANY PARTICULAR FONT, STYLE, SIZE, OR COLOR.

NO CLAIM IS MADE TO THE EXCLUSIVE RIGHT TO USE "RUN", APART FROM THE MARK AS SHOWN.

FOR COMPUTER APPLICATION SOFTWARE FOR MOBILE PHONES, NAMELY, SOFTWARE FOR TRACKING FITNESS DATA AND PROVIDING FITNESS RECOMMENDATIONS (U.S. CLS. 21, 23, 26, 36 AND 38).

FIRST USE 7-11-2011; IN COMMERCE 7-11-2011.

4,017,114. PGMP SOLUTIONS, INC, CHANDLER, AZ. SN 85-128,702. PUB. 2-22-2011, FILED 9-13-2010.

iRelay

THE MARK CONSISTS OF STANDARD CHARACTERS WITHOUT CLAIM TO ANY PARTICULAR FONT, STYLE, SIZE, OR COLOR.

FOR COMPUTER APPLICATION SOFTWARE FOR MOBILE PHONES, PORTABLE MEDIA PLAYERS AND HANDHELD COMPUTERS, NAMELY, SOFTWARE FOR VIEWING AND SHARING PHOTOGRAPHS (U.S. CLS. 21, 23, 26, 36 AND 38).

FIRST USE 11-0-2010; IN COMMERCE 11-0-2010.

4,017,102. MAGO SIMMONE A., BAYAMON, PUERTO RICO. SN 85-122,408. PUB. 4-12-2011, FILED 9-2-2010.

RxCase Minder

THE MARK CONSISTS OF STANDARD CHARACTERS WITHOUT CLAIM TO ANY PARTICULAR FONT, STYLE, SIZE, OR COLOR.

FOR DOWNLOADABLE SOFTWARE IN THE NATURE OF A MOBILE APPLICATION FOR REMINDING USERS OF REFILL DATES AND INTAKE TIMES FOR PRESCRIPTIONS GIVEN TO THEM, ACCORDING TO DATA INPUT TO THE SOFTWARE (U.S. CLS. 21, 23, 26, 36 AND 38).

FIRST USE 9-25-2010; IN COMMERCE 9-25-2010.

4,017,118. AINSWORTH GAME TECHNOLOGY, NEWINGTON, AUSTRALIA. SN 85-129,577. PUB. 11-9-2010, FILED 9-14-2010.

Rio Express

THE MARK CONSISTS OF STANDARD CHARACTERS WITHOUT CLAIM TO ANY PARTICULAR FONT, STYLE, SIZE, OR COLOR.

FOR COMPUTER SOFTWARE AND FIRMWARE FOR GAMES OF CHANCE ON ANY COMPUTERIZED PLATFORM, INCLUDING DEDICATED GAMING CONSOLES, VIDEO BASED SLOT MACHINES, REEL BASED SLOT MACHINES, AND VIDEO LOTTERY TERMINALS (U.S. CLS. 21, 23, 26, 36 AND 38).

FIRST USE 6-16-2011; IN COMMERCE 6-16-2011.

CLASS 9—(Continued).

4,017,122. KMC MUSIC, INC., BLOOMFIELD, CT. SN 85-130,812. PUB. 3-8-2011, FILED 9-16-2010.

CLASS 9—(Continued).

4,017,154. NEW POTATO TECHNOLOGIES, INC., WILMINGTON, NC. SN 85-150,259. PUB. 3-15-2011, FILED 10-12-2010.

STREAMLINER

THE MARK CONSISTS OF STANDARD CHARACTERS WITHOUT CLAIM TO ANY PARTICULAR FONT, STYLE, SIZE, OR COLOR.

FOR MUSICAL INSTRUMENT AMPLIFIERS (U.S. CLS. 21, 23, 26, 36 AND 38).

FIRST USE 11-0-2010; IN COMMERCE 1-1-2011.

TuneLink

THE MARK CONSISTS OF STANDARD CHARACTERS WITHOUT CLAIM TO ANY PARTICULAR FONT, STYLE, SIZE, OR COLOR.

FOR CONSUMER ELECTRONICS ACCESSORIES FOR PORTABLE DIGITAL VIDEO AND DIGITAL AUDIO PLAYERS INTENDED FOR AUTOMOTIVE, HOME AND MARINE USE, NAMELY, PERIPHERAL HARDWARE IN THE NATURE OF FM TRANSMITTERS FOR TRANSMISSION OF AUDIO FROM A PORTABLE DIGITAL VIDEO AND DIGITAL AUDIO PLAYER TO A VEHICLE'S SOUND SYSTEM, RADIO FREQUENCY COMMUNICATION TRANSMITTERS AND RECEIVERS USED IN SHORT-RANGE TRANSMISSION OF DATA, WIRED AND WIRELESS LINKS BETWEEN A PORTABLE DIGITAL VIDEO AND DIGITAL AUDIO PLAYER AND A VEHICLE, HOME OR MARINE SOUND SYSTEM, ELECTRONIC DOCKING STATIONS FOR PORTABLE DIGITAL VIDEO AND DIGITAL AUDIO PLAYERS, AND HANDS-FREE SPEAKERPHONES; AND INTEGRATED SOFTWARE IN THE NATURE OF GAME SOFTWARE AND UTILITY PROGRAMS (U.S. CLS. 21, 23, 26, 36 AND 38).

FIRST USE 4-12-2010; IN COMMERCE 11-23-2010.

4,017,137. HOYA CORPORATION, TOKYO, JAPAN. SN 85-137,307. PUB. 3-8-2011, FILED 9-24-2010.

4,017,162. HITCHCOCK, DONALD, SAN CLEMENTE, CA. SN 85-154,669. PUB. 4-26-2011, FILED 10-18-2010.

HOYALUX ID INSTYLE

THE MARK CONSISTS OF STANDARD CHARACTERS WITHOUT CLAIM TO ANY PARTICULAR FONT, STYLE, SIZE, OR COLOR.

OWNER OF U.S. REG. NOS. 2,988,596, 3,780,102, AND OTHERS.

FOR SPECTACLE LENS BLANKS AND SPECTACLE LENSES (U.S. CLS. 21, 23, 26, 36 AND 38).

FIRST USE 10-0-2010; IN COMMERCE 10-0-2010.

FitPac

THE MARK CONSISTS OF STANDARD CHARACTERS WITHOUT CLAIM TO ANY PARTICULAR FONT, STYLE, SIZE, OR COLOR.

FOR SPECIALTY HOLSTER CONSISTING OF AN ASSEMBLY OF FOUR SHOULDER STRAPS AND TWO HOLDER DEVICES WITH MAGNETIC FLAP CLOSURES SET UNDER BOTH ARMPIT AREAS OF THE WEARER, MADE IN VARIATIONS OF COLORS AND MATERIALS SUCH AS HEAVY CLOTH, CANVAS, NYLON, LEATHER OR OTHER MATERIAL FOR CARRYING CELLULAR PHONES, PAGERS, PERSONAL DIGITAL ASSISTANTS, MUSIC PLAYERS, SUNGLASSES AND EYEGLASSES (U.S. CLS. 21, 23, 26, 36 AND 38).

FIRST USE 10-21-2010; IN COMMERCE 12-10-2010.

CLASS 9—(Continued).

4,017,172. CFA INSTITUTE, CHARLOTTESVILLE, VA. SN 85-158,295. PUB. 4-19-2011, FILED 10-21-2010.

GBIK

THE MARK CONSISTS OF STANDARD CHARACTERS WITHOUT CLAIM TO ANY PARTICULAR FONT, STYLE, SIZE, OR COLOR.

FOR DOWNLOADABLE PUBLICATIONS IN THE NATURE OF REFERENCE GUIDES FEATURING A COMPREHENSIVE OUTLINE OF TOPICS AND PRACTICE ANALYSIS FOR INVESTMENT PROFESSIONALS AND FINANCIAL ANALYSTS IN THE FIELDS OF INVESTMENT MANAGEMENT AND FINANCIAL ANALYSIS (U.S. CLS. 21, 23, 26, 36 AND 38).

FIRST USE 9-0-2009; IN COMMERCE 9-0-2009.

4,017,189. ALEXANDER ANDREW, INC., DBA FALLTECH, COMPTON, CA. SN 85-167,624. PUB. 3-29-2011, FILED 11-2-2010.

FlowTech

THE MARK CONSISTS OF STANDARD CHARACTERS WITHOUT CLAIM TO ANY PARTICULAR FONT, STYLE, SIZE, OR COLOR.

FOR FALL PROTECTION EQUIPMENT FOR FALL RESTRAINT AND FALL ARREST, NAMELY, HARNESSSES (U.S. CLS. 21, 23, 26, 36 AND 38).

FIRST USE 10-10-2010; IN COMMERCE 3-1-2011.

4,017,196. ABB INC., CARY, NC. SN 85-170,046. PUB. 3-1-2011, FILED 11-5-2010.

GRIDSHIELD

THE MARK CONSISTS OF STANDARD CHARACTERS WITHOUT CLAIM TO ANY PARTICULAR FONT, STYLE, SIZE, OR COLOR.

FOR RECLOSERS (U.S. CLS. 21, 23, 26, 36 AND 38).

FIRST USE 6-1-2011; IN COMMERCE 6-1-2011.

CLASS 9—(Continued).

4,017,212. MENTOR GRAPHICS CORPORATION, WILSONVILLE, OR. SN 85-178,689. PUB. 4-12-2011, FILED 11-17-2010.

INFLEXION

THE MARK CONSISTS OF STANDARD CHARACTERS WITHOUT CLAIM TO ANY PARTICULAR FONT, STYLE, SIZE, OR COLOR.

FOR EMBEDDED SOFTWARE FOR CREATING GRAPHICAL USER INTERFACES (U.S. CLS. 21, 23, 26, 36 AND 38).

FIRST USE 6-0-2007; IN COMMERCE 9-0-2008.

4,017,225. CONTINENTAL SECURITY INDUSTRIES, SANTA CLARITA, CA. SN 85-186,719. PUB. 4-12-2011, FILED 11-29-2010.



THE MARK CONSISTS OF TWO LINES WITH THE STYLIZED TEXT "CSI".

FOR ACCESS CONTROL AND ALARM MONITORING SYSTEMS; BURGLAR ALARMS; CLOSED CIRCUIT TV SYSTEMS FOR SECURITY AND SURVEILLANCE, NAMELY, CAMERAS, SWITCHERS, MONITORS, MICROPHONES, AND RECORDERS; SECURITY AND FIRE ALARMS; SECURITY PRODUCTS, NAMELY, ENTRY DOOR SYSTEMS COMPRISING TOUCH PADS AND SECURITY DOORS (U.S. CLS. 21, 23, 26, 36 AND 38).

FIRST USE 1-15-2000; IN COMMERCE 1-15-2000.

4,017,243. SOURCEFIRE, INC., COLUMBIA, MD. SN 85-212,876. PUB. 5-10-2011, FILED 1-7-2011.

SOURCEFIRE IPSX

THE MARK CONSISTS OF STANDARD CHARACTERS WITHOUT CLAIM TO ANY PARTICULAR FONT, STYLE, SIZE, OR COLOR.

OWNER OF U.S. REG. NOS. 2,673,312, 3,589,024, AND OTHERS.

FOR COMPUTER SOFTWARE AND HARDWARE FOR USE IN COMPUTER NETWORK SECURITY INTRUSION DETECTION, FILTERING AND ANALYSIS (U.S. CLS. 21, 23, 26, 36 AND 38).

FIRST USE 4-18-2011; IN COMMERCE 4-18-2011.

CLASS 10—MEDICAL APPARATUS

4,016,215. GUST, DAVID, CHICAGO, IL. SN 77-327,416. PUB. 4-1-2008, FILED 11-12-2007.

PINK POWER

THE MARK CONSISTS OF STANDARD CHARACTERS WITHOUT CLAIM TO ANY PARTICULAR FONT, STYLE, SIZE, OR COLOR.

NO CLAIM IS MADE TO THE EXCLUSIVE RIGHT TO USE "PINK", APART FROM THE MARK AS SHOWN.

FOR GLOVES FOR MEDICAL USE; DISPOSABLE MEDICAL SUPPLIES, NAMELY, MEDICAL GOWNS, SHOE COVERS, SURGICAL MASKS, SURGICAL CAPS AND TOURNIQUETS (U.S. CLS. 26, 39 AND 44).

FIRST USE 6-16-2011; IN COMMERCE 6-16-2011.

4,016,219. NANOPASS TECHNOLOGIES, LTD., PARK HA'MADA NES-ZIONA, ISRAEL. SN 77-333,909. PUB. 10-21-2008, FILED 11-20-2007.

MICRONJET

THE MARK CONSISTS OF STANDARD CHARACTERS WITHOUT CLAIM TO ANY PARTICULAR FONT, STYLE, SIZE, OR COLOR.

FOR DEVICE FOR INTRADERMAL DELIVERY, NAMELY, A NEEDLE (U.S. CLS. 26, 39 AND 44).

FIRST USE 7-1-2011; IN COMMERCE 7-1-2011.

4,016,229. OSYPKA MEDICAL GMBH, BERLIN, FED REP GERMANY. SN 77-347,412. PUB. 5-6-2008, FILED 12-8-2007.

PSA

THE MARK CONSISTS OF STANDARD CHARACTERS WITHOUT CLAIM TO ANY PARTICULAR FONT, STYLE, SIZE, OR COLOR.

FOR CARDIAC PACEMAKERS (U.S. CLS. 26, 39 AND 44).

FIRST USE 7-1-2010; IN COMMERCE 5-15-2011.

CLASS 10—(Continued).

4,016,230. OSYPKA MEDICAL GMBH, BERLIN, FED REP GERMANY. SN 77-347,415. PUB. 5-6-2008, FILED 12-8-2007.

PSA 300

THE MARK CONSISTS OF STANDARD CHARACTERS WITHOUT CLAIM TO ANY PARTICULAR FONT, STYLE, SIZE, OR COLOR.

FOR CARDIAC PACEMAKERS (U.S. CLS. 26, 39 AND 44).

FIRST USE 7-1-2010; IN COMMERCE 5-15-2011.

4,016,274. WRIGHT MEDICAL TECHNOLOGY, INC., AR-LINGTON, TN. SN 77-529,699. PUB. 10-14-2008, FILED 7-23-2008.

TOMAHAWK

THE MARK CONSISTS OF STANDARD CHARACTERS WITHOUT CLAIM TO ANY PARTICULAR FONT, STYLE, SIZE, OR COLOR.

FOR MEDICAL DEVICES, NAMELY, ORTHOPEDIC EXTERNAL FIXATION DEVICES FOR TREATMENT OF BONE FRACTURES AND DISEASES (U.S. CLS. 26, 39 AND 44).

FIRST USE 4-29-2011; IN COMMERCE 4-29-2011.

4,016,320. CATHETER CONNECTIONS, SALT LAKE CITY, UT. SN 77-705,439. PUB. 10-19-2010, FILED 4-2-2009.

CATHETER CONNECTIONS

THE MARK CONSISTS OF STANDARD CHARACTERS WITHOUT CLAIM TO ANY PARTICULAR FONT, STYLE, SIZE, OR COLOR.

NO CLAIM IS MADE TO THE EXCLUSIVE RIGHT TO USE "CATHETER", APART FROM THE MARK AS SHOWN.

FOR MEDICAL APPARATUS, NAMELY, CLOSURES FOR USE IN COVERING AND DISINFECTING THE ENDS AND PORTS OF FLUID TRANSPORTATION LINES FOR TRANSFERRING FLUIDS INTRAVENOUSLY, NAMELY, SALINE, BLOOD, MEDICATIONS AND PARENTERAL NUTRITION (U.S. CLS. 26, 39 AND 44).

FIRST USE 2-6-2008; IN COMMERCE 5-12-2011.

CLASS 10—(Continued).

4,016,340. SAFESHOT TECHNOLOGIES, LLC, MISSION VIEJO, CA. SN 77-747,933. PUB. 10-6-2009, FILED 5-29-2009.

SAFESHOT

THE MARK CONSISTS OF STANDARD CHARACTERS WITHOUT CLAIM TO ANY PARTICULAR FONT, STYLE, SIZE, OR COLOR.

FOR MEDICAL INSTRUMENT, NAMELY, A SYRINGE (U.S. CLS. 26, 39 AND 44).

FIRST USE 1-1-2006; IN COMMERCE 1-1-2006.

4,016,343. PIVOT MEDICAL, INC., SUNNYVALE, CA. SN 77-748,854. PUB. 5-4-2010, FILED 6-1-2009.

NANOTACK

THE MARK CONSISTS OF STANDARD CHARACTERS WITHOUT CLAIM TO ANY PARTICULAR FONT, STYLE, SIZE, OR COLOR.

FOR MEDICAL DEVICES, NAMELY, INSTRUMENTS FOR USE IN ARTHROSCOPIC SURGERY, NAMELY, ORTHOPEDIC FIXATION DEVICES (U.S. CLS. 26, 39 AND 44).

FIRST USE 6-13-2011; IN COMMERCE 6-13-2011.

4,016,345. WING POW INTERNATIONAL CORP., CHATSWORTH, CA. SN 77-749,951. PUB. 10-20-2009, FILED 6-2-2009.

WETJOY

THE MARK CONSISTS OF STANDARD CHARACTERS WITHOUT CLAIM TO ANY PARTICULAR FONT, STYLE, SIZE, OR COLOR.

FOR ADULT SEXUAL STIMULATION AIDS, NAMELY, VIBRATORS AND VIBRATOR SLEEVES, IMITATION PENISES, DEVICES FOR AIDING IN MASTURBATION AND SEXUAL INTERCOURSE, NAMELY, REPRODUCTIONS OF THE MALE ANATOMY, AND STIMULATION DEVICES FOR AIDING IN SEXUAL AROUSAL AND SEXUAL PERFORMANCE IN THE NATURE OF DILDOS, DONGS AND PLUGS; ELECTRIC AND NON-ELECTRIC MASSAGE APPARATUS FOR MASSAGING OR VIBRATING PORTIONS OF THE FACE AND BODY (U.S. CLS. 26, 39 AND 44).

FIRST USE 4-0-2011; IN COMMERCE 4-0-2011.

CLASS 10—(Continued).

4,016,370. NORBIS INNOVATIONS COMPANY, LLC, BROOKLINE, MA. SN 77-777,476. PUB. 11-30-2010, FILED 7-9-2009.

ACUSSAGER

THE MARK CONSISTS OF STANDARD CHARACTERS WITHOUT CLAIM TO ANY PARTICULAR FONT, STYLE, SIZE, OR COLOR.

FOR MASSAGE APPARATUS; MASSAGING APPARATUS FOR PERSONAL USE (U.S. CLS. 26, 39 AND 44).

FIRST USE 2-16-2011; IN COMMERCE 2-16-2011.

4,016,419. ALLIED 100, LLC, WOODRUFF, WI. SN 77-852,244. PUB. 11-9-2010, FILED 10-19-2009.

RESPONDER

THE MARK CONSISTS OF THE WORD "RESPONDER" IN CAPITAL LETTERING, WITH THE LETTERS "ER" IN LARGER FONT, AND SOLID BARS ON BOTH THE TOP AND THE BOTTOM OF THE LETTERS "RESPOND".

FOR MEDICAL KITS FOR EMERGENCY RESCUE COMPOSED OF CPR FACE MASKS, CPR BARRIERS, NITRILE GLOVES, SHEARS, RAZORS, ABSORBENT TOWELS, ANTISEPTIC TOWELETTES, AND BAGS FOR STORING MEDICAL WASTE MATERIALS; CPR BARRIERS, NAMELY, SANITARY MASKS FOR PERFORMING CPR (U.S. CLS. 26, 39 AND 44).

FIRST USE 8-15-2008; IN COMMERCE 8-15-2008.

4,016,513. JOERNS HEALTHCARE, LLC, STEVENS POINT, WI. SN 77-897,795. PUB. 5-18-2010, FILED 12-21-2009.

CALIBRE

THE MARK CONSISTS OF STANDARD CHARACTERS WITHOUT CLAIM TO ANY PARTICULAR FONT, STYLE, SIZE, OR COLOR.

FOR INVALID LIFTS (U.S. CLS. 26, 39 AND 44).

FIRST USE 6-1-2011; IN COMMERCE 6-1-2011.

CLASS 10—(Continued).

4,016,586. X-SPINE SYSTEMS, INC., MIAMISBURG, OH. SN 77-936,172. PUB. 7-6-2010, FILED 2-16-2010.

AXLE

THE MARK CONSISTS OF STANDARD CHARACTERS WITHOUT CLAIM TO ANY PARTICULAR FONT, STYLE, SIZE, OR COLOR.

FOR MEDICAL AND SURGICAL APPARATUS AND INSTRUMENTS, NAMELY, ORTHOPEDIC FIXATION DEVICE USED IN ORTHOPEDIC TRANSPLANT AND/OR IMPLANT SURGERY (U.S. CLS. 26, 39 AND 44).

FIRST USE 1-25-2011; IN COMMERCE 1-25-2011.

4,016,650. TRUNK HEALTH, INC., SAN DIEGO, CA. SN 77-960,343. PUB. 3-29-2011, FILED 3-16-2010.



NO CLAIM IS MADE TO THE EXCLUSIVE RIGHT TO USE "CONDOMS", APART FROM THE MARK AS SHOWN. THE COLOR(S) BLACK, WHITE, GREY AND PINK IS/ARE CLAIMED AS A FEATURE OF THE MARK.

THE MARK CONSISTS OF A GREY AND WHITE ELEPHANT WITH A PINK CONDOM OVER ITS NOSE ON A BLACK SQUARE. BENEATH THE ELEPHANT IS THE WORD "TRUNK" IN WHITE. BELOW "TRUNK" IS THE WORD "CONDOMS" IN PINK.

FOR CONDOMS (U.S. CLS. 26, 39 AND 44).
FIRST USE 9-1-2010; IN COMMERCE 9-1-2010.

4,016,663. CACTUS, LLC, CHARLESTON, SC. SN 77-967,445. PUB. 8-24-2010, FILED 3-24-2010.

SMART SINK

THE MARK CONSISTS OF STANDARD CHARACTERS WITHOUT CLAIM TO ANY PARTICULAR FONT, STYLE, SIZE, OR COLOR.

FOR PHARMACEUTICAL AND MEDICAL WASTE CONTAINERS (U.S. CLS. 26, 39 AND 44).

FIRST USE 5-13-2011; IN COMMERCE 5-13-2011.

CLASS 10—(Continued).

4,016,665. ACUFOCUS, INC., IRVINE, CA. SN 77-968,787. PUB. 8-17-2010, FILED 3-25-2010.

ACUTARGET

THE MARK CONSISTS OF STANDARD CHARACTERS WITHOUT CLAIM TO ANY PARTICULAR FONT, STYLE, SIZE, OR COLOR.

FOR SURGICAL TOOL FOR AIDING CENTRATION OF A CORNEAL INLAY OR INTRAOCULAR IMPLANT; OPHTHALMIC DIAGNOSTIC DEVICE FOR IDENTIFYING THE CENTER OF THE PUPIL AND LINE OF SIGHT (U.S. CLS. 26, 39 AND 44).

FIRST USE 9-6-2010; IN COMMERCE 5-20-2011.

4,016,902. SONIC INNOVATIONS, INC., SALT LAKE CITY, UT. SN 85-064,451. PUB. 4-12-2011, FILED 6-16-2010.

GROOVE

THE MARK CONSISTS OF STANDARD CHARACTERS WITHOUT CLAIM TO ANY PARTICULAR FONT, STYLE, SIZE, OR COLOR.

FOR HEARING AIDS (U.S. CLS. 26, 39 AND 44).
FIRST USE 3-29-2011; IN COMMERCE 3-29-2011.

4,016,965. HOTSPUR TECHNOLOGIES, INC., MOUNTAIN VIEW, CA. SN 85-077,625. PUB. 11-2-2010, FILED 7-2-2010.

GPSCATH

THE MARK CONSISTS OF STANDARD CHARACTERS WITHOUT CLAIM TO ANY PARTICULAR FONT, STYLE, SIZE, OR COLOR.

FOR MEDICAL APPARATUS AND INSTRUMENTS FOR TREATING CARDIOVASCULAR DISEASE; MEDICAL DEVICES TO TREAT INTRAVASCULAR SITES (U.S. CLS. 26, 39 AND 44).

FIRST USE 10-27-2010; IN COMMERCE 10-31-2010.

CLASS 10—(Continued).

4,017,075. KENT DINUCCI, OMAHA, NE. SN 85-110,421. PUB. 2-15-2011, FILED 8-18-2010.

FOOT-CHAIR

THE MARK CONSISTS OF STANDARD CHARACTERS WITHOUT CLAIM TO ANY PARTICULAR FONT, STYLE, SIZE, OR COLOR.

NO CLAIM IS MADE TO THE EXCLUSIVE RIGHT TO USE "FOOT", APART FROM THE MARK AS SHOWN.

FOR ARCH SUPPORTS FOR FOOTWEAR, INCLUDING SANDALS, SHOES AND BOOTS (U.S. CLS. 26, 39 AND 44).

FIRST USE 10-1-2010; IN COMMERCE 11-30-2010.

4,017,165. CEANIX HEALTH INC., COLLINGWOOD, CANADA. SN 85-155,219. PUB. 3-22-2011, FILED 10-18-2010.

Tortoise Shellz

THE MARK CONSISTS OF STANDARD CHARACTERS WITHOUT CLAIM TO ANY PARTICULAR FONT, STYLE, SIZE, OR COLOR.

FOR INFRARED RADIATOR UNITS FOR THERAPEUTIC PURPOSES (U.S. CLS. 26, 39 AND 44).

FIRST USE 1-27-2011; IN COMMERCE 1-27-2011.

4,017,166. OMNIGLOW, LLC, WEST SPRINGFIELD, MA. SN 85-155,224. PUB. 4-12-2011, FILED 10-18-2010.

STYLITE

THE MARK CONSISTS OF STANDARD CHARACTERS WITHOUT CLAIM TO ANY PARTICULAR FONT, STYLE, SIZE, OR COLOR.

FOR MEDICAL INTUBATION EQUIPMENT; CHEMILUMINESCENT ILLUMINATED MEDICAL INTUBATION EQUIPMENT; CHEMILUMINESCENT ILLUMINATED INTUBATION STYLETS; CHEMILUMINESCENT ILLUMINATED MEDICAL INSTRUMENTS FOR VISUALLY EXAMINING THE INSIDE OF THE BODY (U.S. CLS. 26, 39 AND 44).

FIRST USE 10-0-2010; IN COMMERCE 4-1-2011.

CLASS 10—(Continued).

4,017,182. AMERICAN MASTERTECH SCIENTIFIC, INC., DBA AMERICAN MASTERTECH SCIENTIFIC, INC., LODI, CA. SN 85-165,252. PUB. 4-26-2011, FILED 10-29-2010.

XISH

THE MARK CONSISTS OF STANDARD CHARACTERS WITHOUT CLAIM TO ANY PARTICULAR FONT, STYLE, SIZE, OR COLOR.

FOR MEDICAL PROBE KITS CONSISTING OF CHROMOGENIC IN SITU HYBRIDIZATION PROBES (U.S. CLS. 26, 39 AND 44).

FIRST USE 1-1-2011; IN COMMERCE 1-1-2011.

4,017,184. DARBY DENTAL SUPPLY, LLC, JERICHO, NY. SN 85-165,994. PUB. 4-12-2011, FILED 11-1-2010.



HANDSON
Gloves that FIT the needs of every practice.

OWNER OF U.S. REG. NO. 3,553,914.

THE COLOR(S) BLACK AND BROWN IS/ARE CLAIMED AS A FEATURE OF THE MARK.

THE MARK CONSISTS OF THE STYLIZED WORDING "HANDSON", WITH THE LETTER "O" FORMED BY A STYLIZED DEPICTION OF A HAND, ALL SET ABOVE THE STYLIZED WORDING "GLOVES THE FIT THE NEEDS OF EVERY PRACTICE." THE COLOR BLACK APPEARS IN THE LETTERING "HANDS" IN THE TERM "HANDSON" AND IN THE WORDING "GLOVES THAT FIT THE NEEDS OF EVERY PRACTICE."; THE COLOR BROWN APPEARS IN THE STYLIZED DEPICTION OF THE HAND FORMING THE LETTER "O" IN THE TERM "HANDSON" AND IN THE SECOND LETTER "N" IN THE TERM "HANDSON".

FOR MEDICAL AND DENTAL EXAMINATION GLOVES (U.S. CLS. 26, 39 AND 44).

FIRST USE 1-12-2011; IN COMMERCE 1-12-2011.

4,017,201. NEO-FLO, INC., DBA MICROCOPY, KENNESAW, GA. SN 85-171,648. PUB. 3-29-2011, FILED 11-8-2010.

XACTFIT

THE MARK CONSISTS OF STANDARD CHARACTERS WITHOUT CLAIM TO ANY PARTICULAR FONT, STYLE, SIZE, OR COLOR.

FOR DENTAL BURRS; DENTAL DRILLS (U.S. CLS. 26, 39 AND 44).

FIRST USE 12-11-2010; IN COMMERCE 12-11-2010.

CLASS 10—(Continued).

4,017,202. BSN MEDICAL GMBH, HAMBURG, FED REP GERMANY. SN 85-171,808. PUB. 4-5-2011, FILED 11-8-2010.

MAKES YOUR LEGS LOOK AS
GOOD AS THEY FEEL!

THE MARK CONSISTS OF STANDARD CHARACTERS WITHOUT CLAIM TO ANY PARTICULAR FONT, STYLE, SIZE, OR COLOR.

FOR ORTHOPAEDIC HOSIERY, NAMELY, ORTHOPAEDIC COMPRESSION AND SUPPORT STOCKINGS, TIGHTS AND SOCKS; MEDICAL HOSIERY, NAMELY, MEDICAL AND SUPPORT STOCKINGS, TIGHTS AND SOCKS (U.S. CLS. 26, 39 AND 44).

FIRST USE 1-0-2005; IN COMMERCE 1-0-2005.

4,017,233. PRODIGY DIABETES CARE, LLC, CHARLOTTE, NC. SN 85-195,580. PUB. 4-19-2011, FILED 12-10-2010.

MINI-MIST

THE MARK CONSISTS OF STANDARD CHARACTERS WITHOUT CLAIM TO ANY PARTICULAR FONT, STYLE, SIZE, OR COLOR.

FOR NEBULIZERS FOR RESPIRATION THERAPY (U.S. CLS. 26, 39 AND 44).

FIRST USE 6-14-2011; IN COMMERCE 6-14-2011.

CLASS 11—ENVIRONMENTAL CONTROL APPARATUS

4,016,165. FAN FI INTERNATIONAL, INC., SPARKS, NV. SN 76-705,671. PUB. 5-3-2011, FILED 12-13-2010.

BELLA LUCE

THE MARK CONSISTS OF STANDARD CHARACTERS WITHOUT CLAIM TO ANY PARTICULAR FONT, STYLE, SIZE, OR COLOR.

NO CLAIM IS MADE TO THE EXCLUSIVE RIGHT TO USE "LUCE", APART FROM THE MARK AS SHOWN.

THE ENGLISH TRANSLATION OF "BELLA LUCE" IS "BEAUTIFUL LIGHT".

FOR LAMPS, NAMELY, ELECTRIC LAMPS (U.S. CLS. 13, 21, 23, 31 AND 34).

FIRST USE 3-0-2011; IN COMMERCE 3-0-2011.

CLASS 11—(Continued).

4,016,224. VAPOR POWER INTERNATIONAL, LLC, FRANKLIN PARK, IL. SN 77-345,679. PUB. 5-26-2009, FILED 12-6-2007.

Whirlpower

THE MARK CONSISTS OF STANDARD CHARACTERS WITHOUT CLAIM TO ANY PARTICULAR FONT, STYLE, SIZE, OR COLOR.

FOR GAS AND OIL BURNERS FOR USE IN STEEL AND CAST IRON INDUSTRIAL FIRE-TUBE BOILERS (U.S. CLS. 13, 21, 23, 31 AND 34).

FIRST USE 2-1-1962; IN COMMERCE 2-1-1962.

4,016,258. GRAND HALL USA, INC., GARLAND, TX. SN 77-470,445. PUB. 9-16-2008, FILED 5-9-2008.

TOTUM

THE MARK CONSISTS OF STYLIZED TEXT READING "TOTUM" WHICH APPEARS IN ALL CAPITAL LETTERS.

FOR GAS PATIO HEATERS (U.S. CLS. 13, 21, 23, 31 AND 34).

FIRST USE 11-15-2008; IN COMMERCE 12-26-2008.

4,016,259. GREEN TURTLE AMERICAS LTD., CHARLOTTE, NC. SN 77-471,528. PUB. 10-14-2008, FILED 5-12-2008.

MICROCEPTOR

THE MARK CONSISTS OF STANDARD CHARACTERS WITHOUT CLAIM TO ANY PARTICULAR FONT, STYLE, SIZE, OR COLOR.

FOR A SEPARATOR UNIT FOR REMOVAL AND STORAGE OF OIL, GREASE AND SEDIMENT FROM EFFLUENCE DISCHARGED TO THE SANITARY SEWER (U.S. CLS. 13, 21, 23, 31 AND 34).

FIRST USE 3-1-2011; IN COMMERCE 3-1-2011.

CLASS 11—(Continued).

4,016,498. CLARCOR AIR FILTRATION PRODUCTS, INC., JEFFERSONVILLE, IN. SN 77-894,595. PUB. 5-18-2010, FILED 12-16-2009.

PUROSTATIC

THE MARK CONSISTS OF STANDARD CHARACTERS WITHOUT CLAIM TO ANY PARTICULAR FONT, STYLE, SIZE, OR COLOR.

FOR RESIDENTIAL HVAC FILTERS; A FEATURE OF RESIDENTIAL HVAC FILTERS COMPRISING AN ELECTROSTATIC CHARGE IMPARTED TO THE MEDIA IN AIR FILTERS (U.S. CLS. 13, 21, 23, 31 AND 34).

FIRST USE 9-0-2009; IN COMMERCE 9-0-2009.

CLASS 11—(Continued).

4,016,630. PALMER FIXTURE COMPANY, GREEN BAY, WI. SN 77-950,348. PUB. 3-22-2011, FILED 3-4-2010.

EcoStorm

THE MARK CONSISTS OF STANDARD CHARACTERS WITHOUT CLAIM TO ANY PARTICULAR FONT, STYLE, SIZE, OR COLOR.

FOR ELECTRIC HOT AIR HAND DRYERS (U.S. CLS. 13, 21, 23, 31 AND 34).

FIRST USE 6-21-2010; IN COMMERCE 6-21-2010.

4,016,539. OPCOM INC., TAIPEI HSIEN, TAIWAN. SN 77-910,519. PUB. 6-1-2010, FILED 1-12-2010.

OPCOM

THE MARK CONSISTS OF STANDARD CHARACTERS WITHOUT CLAIM TO ANY PARTICULAR FONT, STYLE, SIZE, OR COLOR.

FOR LED (LIGHT EMITTING DIODES) LIGHTING FIXTURES FOR USE IN DISPLAY, COMMERCIAL, INDUSTRIAL, RESIDENTIAL, AND ARCHITECTURAL ACCENT LIGHTING APPLICATIONS; LED LIGHT BULBS; LED LIGHT ASSEMBLIES FOR STREET LIGHTS, SIGNS, COMMERCIAL LIGHTING, AUTOMOBILES, BUILDINGS, AND OTHER ARCHITECTURAL USES; LIGHTING LAMPS; ELECTRIC LAMPS (U.S. CLS. 13, 21, 23, 31 AND 34).

FIRST USE 4-1-2010; IN COMMERCE 3-21-2011.

4,016,632. THE LED GUY FOR YOU, IRVINE, CA. SN 77-951,550. PUB. 7-27-2010, FILED 3-5-2010.

THE LED GUY FOR YOU

THE MARK CONSISTS OF STANDARD CHARACTERS WITHOUT CLAIM TO ANY PARTICULAR FONT, STYLE, SIZE, OR COLOR.

FOR LED LIGHT BULBS AND LED LIGHT FIXTURES (U.S. CLS. 13, 21, 23, 31 AND 34).

FIRST USE 1-1-2010; IN COMMERCE 1-1-2010.

4,016,579. GENPRO POWER SYSTEMS, INC., RAPID CITY, SD. SN 77-933,475. PUB. 6-29-2010, FILED 2-11-2010.

PureDak

THE MARK CONSISTS OF STANDARD CHARACTERS WITHOUT CLAIM TO ANY PARTICULAR FONT, STYLE, SIZE, OR COLOR.

FOR WATER PURIFICATION UNITS (U.S. CLS. 13, 21, 23, 31 AND 34).

FIRST USE 3-10-2010; IN COMMERCE 10-1-2010.

4,016,653. PHOSEON TECHNOLOGY, INC., HILLSBORO, OR. SN 77-963,775. PUB. 3-1-2011, FILED 3-19-2010.

SLM

THE MARK CONSISTS OF STANDARD CHARACTERS WITHOUT CLAIM TO ANY PARTICULAR FONT, STYLE, SIZE, OR COLOR.

FOR LIGHT CURING SYSTEMS COMPOSED PRIMARILY OF LIGHT EMITTING DIODES FOR INDUSTRIAL APPLICATIONS; UV CURING SYSTEMS COMPOSED PRIMARILY OF LIGHT EMITTING DIODES, FOR COMMERCIAL APPLICATIONS, NAMELY, FOR CURING INKS, COATINGS, ADHESIVES, AND A VARIETY OF OTHER MATERIALS (U.S. CLS. 13, 21, 23, 31 AND 34).

FIRST USE 5-3-2005; IN COMMERCE 5-3-2005.

CLASS 11—(Continued).

4,016,673. GREAT LAKES ELECTRIC LLC, STEVENSVILLE, MI. SN 77-981,965. PUB. 2-16-2010, FILED 6-9-2009.



THE MARK CONSISTS OF THE LETTERS "GLE" WITHIN AN INCOMPLETE OVAL.

FOR SOLAR HEAT COLLECTION PANELS; AND SOLAR HEATING SYSTEM KITS COMPRISED OF SOLAR HEAT COLLECTION PANELS, METAL STRUCTURES AND MOUNTING HARDWARE FOR MOUNTING OR ERECTING SOLAR HEAT COLLECTION PANELS (U.S. CLS. 13, 21, 23, 31 AND 34).

FIRST USE 8-9-2010; IN COMMERCE 8-9-2010.

4,016,848. NECTAR, INC., LONG BEACH, CA. SN 85-049,498. PUB. 10-26-2010, FILED 5-27-2010.

SOLARFLORA

THE MARK CONSISTS OF STANDARD CHARACTERS WITHOUT CLAIM TO ANY PARTICULAR FONT, STYLE, SIZE, OR COLOR.

FOR LIGHT FIXTURES, NAMELY, OUTDOOR SOLAR POWERED LIGHTING UNITS AND FIXTURES (U.S. CLS. 13, 21, 23, 31 AND 34).

FIRST USE 2-0-2011; IN COMMERCE 2-0-2011.

CLASS 11—(Continued).

4,016,874. KRAFT FOODS SCHWEIZ HOLDING GMBH, 6301 ZUG, SWITZERLAND. SN 85-056,080. PUB. 11-2-2010, FILED 6-7-2010.

TASSIMO



OWNER OF U.S. REG. NOS. 3,030,372, 3,069,128, AND 3,074,435.

THE MARK CONSISTS OF THE WORD "TASSIMO" CENTERED ABOVE A GEOMETRIC DESIGN OF INTERSECTING CIRCLES.

THE WORDING "TASSIMO" HAS NO MEANING IN A FOREIGN LANGUAGE.

FOR ELECTRIC COFFEE MAKERS (U.S. CLS. 13, 21, 23, 31 AND 34).

FIRST USE 5-0-2011; IN COMMERCE 5-0-2011.

4,016,876. BATH & BODY WORKS BRAND MANAGEMENT, INC., REYNOLDSBURG, OH. SN 85-058,186. PUB. 10-26-2010, FILED 6-9-2010.

SPARKLE WALLFLOWERS

THE MARK CONSISTS OF STANDARD CHARACTERS WITHOUT CLAIM TO ANY PARTICULAR FONT, STYLE, SIZE, OR COLOR.

OWNER OF U.S. REG. NO. 2,441,521.

FOR ELECTRIC DISPENSER FOR AIR FRESHENER, ELECTRIC DISPENSERS FOR AIR FRESHENERS AND DEODORIZERS TO BE PLUGGED INTO WALL OUTLETS, DISPENSING UNITS FOR AIR FRESHENERS, ELECTRIC AIR DEODORIZERS, DIFFUSERS FOR AIR FRESHENERS, DISPENSING UNITS FOR ROOM DEODORANTS, ELECTRIC ROOM DEODORIZING UNITS (U.S. CLS. 13, 21, 23, 31 AND 34).

FIRST USE 11-1-2010; IN COMMERCE 11-1-2010.

CLASS 11—(Continued).

4,016,880. SHINWA GRILLS, LLC, FRANKLIN PARK, IL. SN 85-058,986. PUB. 11-16-2010, FILED 6-9-2010.

SHINWA

THE MARK CONSISTS OF STANDARD CHARACTERS WITHOUT CLAIM TO ANY PARTICULAR FONT, STYLE, SIZE, OR COLOR.

THE ENGLISH TRANSLATION OF THE WORD "SHINWA" IN THE MARK IS "FRIENDSHIP, HARMONY, MYTH, LEGEND".

FOR TABLES CONTAINING A BARBEQUE GRILL; BARBEQUE GRILLS (U.S. CLS. 13, 21, 23, 31 AND 34). FIRST USE 5-15-2011; IN COMMERCE 5-15-2011.

4,016,881. SHINWA GRILLS, LLC, FRANKLIN PARK, IL. SN 85-058,991. PUB. 11-16-2010, FILED 6-9-2010.

SHINWA

THE MARK CONSISTS OF THE WORD "SHINWA" IN A STYLIZED FONT.

THE ENGLISH TRANSLATION OF THE WORD "SHINWA" IN THE MARK IS "FRIENDSHIP, HARMONY, MYTH, LEGEND".

FOR TABLES CONTAINING A BARBEQUE GRILL; BARBEQUE GRILLS (U.S. CLS. 13, 21, 23, 31 AND 34). FIRST USE 5-15-2011; IN COMMERCE 5-15-2011.

4,016,882. HONEYWELL INTERNATIONAL INC., MORRISTOWN, NJ. SN 85-059,082. PUB. 11-2-2010, FILED 6-10-2010.

TRUE EASE

THE MARK CONSISTS OF STANDARD CHARACTERS WITHOUT CLAIM TO ANY PARTICULAR FONT, STYLE, SIZE, OR COLOR.

FOR HUMIDIFIERS (U.S. CLS. 13, 21, 23, 31 AND 34). FIRST USE 8-1-2010; IN COMMERCE 8-18-2010.

CLASS 11—(Continued).

4,016,953. HPL, LLC, GILBERT, AZ. SN 85-074,447. PUB. 4-12-2011, FILED 6-30-2010.

First Aid for Wet Electronics

THE MARK CONSISTS OF STANDARD CHARACTERS WITHOUT CLAIM TO ANY PARTICULAR FONT, STYLE, SIZE, OR COLOR.

NO CLAIM IS MADE TO THE EXCLUSIVE RIGHT TO USE "WET ELECTRONICS", APART FROM THE MARK AS SHOWN.

FOR DEHUMIDIFIERS; DEHUMIDIFIERS FOR HOUSEHOLD USE (U.S. CLS. 13, 21, 23, 31 AND 34). FIRST USE 5-15-2011; IN COMMERCE 5-15-2011.

4,017,009. TRUCK-LITE CO., LLC, FALCONER, NY. SN 85-088,548. PUB. 1-4-2011, FILED 7-20-2010.



THE MARK CONSISTS OF A STYLIZED VERSION OF THE WORDS "FLEX-LITE".

FOR LIGHTS FOR VEHICLES, NAMELY, CLEARANCE AND MARKER LIGHTS (U.S. CLS. 13, 21, 23, 31 AND 34).

FIRST USE 2-28-2010; IN COMMERCE 2-28-2010.

4,017,061. AUTOMATIC FILTERS, INC., LOS ANGELES, CA. SN 85-106,628. PUB. 1-25-2011, FILED 8-12-2010.

FORSTA FILTER

THE MARK CONSISTS OF STANDARD CHARACTERS WITHOUT CLAIM TO ANY PARTICULAR FONT, STYLE, SIZE, OR COLOR.

NO CLAIM IS MADE TO THE EXCLUSIVE RIGHT TO USE "FILTER", APART FROM THE MARK AS SHOWN.

FOR WATER FILTERS (U.S. CLS. 13, 21, 23, 31 AND 34). FIRST USE 8-12-2010; IN COMMERCE 8-12-2010.

CLASS 11—(Continued).

4,017,093. MANITOWOC FOODSERVICE COMPANIES, LLC, MANITOWOC, WI. SN 85-117,703. PUB. 12-7-2010, FILED 8-27-2010.

INDIGO

THE MARK CONSISTS OF STANDARD CHARACTERS WITHOUT CLAIM TO ANY PARTICULAR FONT, STYLE, SIZE, OR COLOR.

FOR MACHINES FOR PRODUCING AND DISPENSING ICE, NAMELY, ICE-MAKING MACHINES FOR COMMERCIAL USE (U.S. CLS. 13, 21, 23, 31 AND 34).
FIRST USE 2-0-2011; IN COMMERCE 2-0-2011.

4,017,094. SUREFIRE, LLC, FOUNTAIN VALLEY, CA. SN 85-118,228. PUB. 2-15-2011, FILED 8-29-2010.

INVICTUS

THE MARK CONSISTS OF STANDARD CHARACTERS WITHOUT CLAIM TO ANY PARTICULAR FONT, STYLE, SIZE, OR COLOR.

FOR ILLUMINATION PRODUCTS, NAMELY, FLASHLIGHTS (U.S. CLS. 13, 21, 23, 31 AND 34).
FIRST USE 6-6-2011; IN COMMERCE 6-6-2011.

4,017,127. KOHLER CO., KOHLER, WI. SN 85-133,166. PUB. 5-3-2011, FILED 9-20-2010.

LITHOCAST

THE MARK CONSISTS OF STANDARD CHARACTERS WITHOUT CLAIM TO ANY PARTICULAR FONT, STYLE, SIZE, OR COLOR.

FOR BATHTUBS (U.S. CLS. 13, 21, 23, 31 AND 34).
FIRST USE 1-31-2011; IN COMMERCE 1-31-2011.

CLASS 11—(Continued).

4,017,194. MAG & BROOK, INC., GARDEN GROVE, CA. SN 85-169,845. PUB. 4-26-2011, FILED 11-4-2010.

NO CLAIM IS MADE TO THE EXCLUSIVE RIGHT TO USE "VIRUS". APART FROM THE MARK AS SHOWN.

THE COLOR(S) LIGHT BLUE IS/ARE CLAIMED AS A FEATURE OF THE MARK.

THE MARK CONSISTS OF THE WORDS "VIRUS ZERO" STYLIZED IN LIGHT BLUE COLOR.

FOR AIR PURIFICATION UNITS; AIR PURIFIERS; AIR PURIFIERS; AIR PURIFYING APPARATUS; AIR PURIFYING APPARATUS AND MACHINES; AIR STERILISERS; ELECTRIC AIR DEODORIZERS; STERILIZERS (U.S. CLS. 13, 21, 23, 31 AND 34).
FIRST USE 12-1-2010; IN COMMERCE 12-1-2010.

CLASS 12—VEHICLES

4,016,173. WHOLESALE TIRES & WHEELS, INC., SANTA FE SPRINGS, CA. SN 77-128,430. PUB. 4-27-2010, FILED 3-12-2007.

G

THE MARK CONSISTS OF STANDARD CHARACTERS WITHOUT CLAIM TO ANY PARTICULAR FONT, STYLE, SIZE, OR COLOR.

FOR AUTOMOBILE WHEELS (U.S. CLS. 19, 21, 23, 31, 35 AND 44).
FIRST USE 6-1-2011; IN COMMERCE 6-1-2011.

4,016,174. WHOLESALE TIRES & WHEELS, INC., SANTA FE SPRINGS, CA. SN 77-128,631. PUB. 4-27-2010, FILED 3-12-2007.

THE MARK CONSISTS OF A STYLIZED VERSION OF THE LETTER "G".

FOR AUTOMOBILE WHEELS (U.S. CLS. 19, 21, 23, 31, 35 AND 44).
FIRST USE 6-1-2011; IN COMMERCE 6-1-2011.

CLASS 12—(Continued).

4,016,175. WHOLESALE TIRES & WHEELS, INC., SANTA FE SPRINGS, CA. SN 77-128,649. PUB. 4-27-2010, FILED 3-12-2007.



THE MARK CONSISTS OF A STYLIZED VERSION OF THE LETTER "G".

FOR AUTOMOBILE WHEELS (U.S. CLS. 19, 21, 23, 31, 35 AND 44).

FIRST USE 6-1-2011; IN COMMERCE 6-1-2011.

4,016,242. NISSAN JIDOSHA KABUSHIKI KAISHA, DBA NISSAN MOTOR CO., LTD., YOKOHAMA-SHI, KANAGAWA, JAPAN. SN 77-380,314. PUB. 5-6-2008, FILED 1-25-2008.

NV2500

THE MARK CONSISTS OF STANDARD CHARACTERS WITHOUT CLAIM TO ANY PARTICULAR FONT, STYLE, SIZE, OR COLOR.

FOR MOTOR VEHICLES, NAMELY, VANS, TRUCKS, PICK-UP TRUCKS AND STRUCTURAL PARTS THEREFOR (U.S. CLS. 19, 21, 23, 31, 35 AND 44).

FIRST USE 2-14-2011; IN COMMERCE 2-14-2011.

4,016,373. TBC TRADEMARKS, LLC, LAS VEGAS, NV. SN 77-785,675. PUB. 5-18-2010, FILED 7-21-2009.

VPS

THE MARK CONSISTS OF STANDARD CHARACTERS WITHOUT CLAIM TO ANY PARTICULAR FONT, STYLE, SIZE, OR COLOR.

FOR TIRES (U.S. CLS. 19, 21, 23, 31, 35 AND 44).
FIRST USE 3-1-2010; IN COMMERCE 3-1-2010.

CLASS 12—(Continued).

4,016,410. INO-PRODUCTS, INC., TORONTO, CANADA. SN 77-839,927. PUB. 3-2-2010, FILED 10-2-2009.

REST-N-ROLL

THE MARK CONSISTS OF STANDARD CHARACTERS WITHOUT CLAIM TO ANY PARTICULAR FONT, STYLE, SIZE, OR COLOR.

FOR CARTS, NAMELY, WHEELED, COLLAPSIBLE CARTS FOR TRANSPORTING AND HAULING OBJECTS AND FOR SEATING (U.S. CLS. 19, 21, 23, 31, 35 AND 44).

FIRST USE 3-27-2010; IN COMMERCE 3-27-2010.

4,016,492. AXN HEAVY DUTY, LLC, GOSHEN, KY. SN 77-892,903. PUB. 10-19-2010, FILED 12-14-2009.



THE MARK CONSISTS OF A CIRCLE SURROUNDING A HEXAGON, THE HEXAGON CONTAINING AN EQUILATERAL TRIANGLE, THE EQUILATERAL TRIANGLE CONTAINING A SMALLER EQUILATERAL TRIANGLE.

FOR LAND VEHICLE PARTS, NAMELY, AXLES, SUSPENSIONS, BRAKES AND BRAKE PARTS, LANDING GEARS, FIFTH WHEELS, AND KING PINS FOR TRAILERS AND SEMI TRAILERS; PARTS FOR TRUCKS, TRACTORS, BUSES, AND COACHES, NAMELY, AXLES, SUSPENSIONS, GEARING, BRAKES AND BRAKE PARTS, FIFTH WHEELS, KING PINS, AND LANDING GEARS; AFTERMARKET AND ORIGINAL EQUIPMENT MANUFACTURER PARTS FOR LAND VEHICLES, NAMELY, AXLES, SUSPENSIONS, GEARING, BRAKES AND BRAKE PARTS, FIFTH WHEELS, KING PINS, AND LANDING GEARS (U.S. CLS. 19, 21, 23, 31, 35 AND 44).

FIRST USE 11-30-2010; IN COMMERCE 11-30-2010.

CLASS 12—(Continued).

4,016,577. SRJ, INC., SCHAUMBURG, IL. SN 77-932,984. PUB. 7-6-2010, FILED 2-10-2010.



THE MARK CONSISTS OF A TRIANGULAR INNER AND OUTER TUBE DESIGN AND THE WORDING "INVERNESS" TO THE RIGHT OF THE DESIGN.
FOR DRIVE SHAFTS FOR LAND VEHICLES (U.S. CLS. 19, 21, 23, 31, 35 AND 44).
FIRST USE 4-1-2011; IN COMMERCE 5-1-2011.

CLASS 12—(Continued).

4,016,625. CHRYSLER GROUP LLC, AUBURN HILLS, MI. SN 77-948,645. PUB. 7-27-2010, FILED 3-2-2010.

NITRO SHOCK

THE MARK CONSISTS OF STANDARD CHARACTERS WITHOUT CLAIM TO ANY PARTICULAR FONT, STYLE, SIZE, OR COLOR.
OWNER OF U.S. REG. NO. 3,262,240.
FOR MOTOR VEHICLES, NAMELY, PASSENGER AUTOMOBILES, THEIR STRUCTURAL PARTS, TRIM AND BADGES (U.S. CLS. 19, 21, 23, 31, 35 AND 44).
FIRST USE 3-0-2010; IN COMMERCE 3-0-2010.

4,016,597. SADORU GROUP, LTD., DELAWARE, OH. SN 77-941,163. PUB. 12-14-2010, FILED 2-22-2010.



THE STIPPLING IS FOR SHADING PURPOSES.
THE MARK CONSISTS OF THE LETTER "S" SUPERIMPOSED UPON AN OBLONG FIELD.
FOR MOTORCYCLE PARTS AND ACCESSORIES, NAMELY, ERGONOMIC MOTORCYCLE PADS FOR USE WITH SEATS (U.S. CLS. 19, 21, 23, 31, 35 AND 44).
FIRST USE 2-28-2010; IN COMMERCE 2-28-2010.

4,016,627. CHRYSLER GROUP LLC, AUBURN HILLS, MI. SN 77-949,168. PUB. 7-27-2010, FILED 3-3-2010.

AVENGER EXPRESS

THE MARK CONSISTS OF STANDARD CHARACTERS WITHOUT CLAIM TO ANY PARTICULAR FONT, STYLE, SIZE, OR COLOR.
OWNER OF U.S. REG. NO. 3,341,833.
FOR MOTOR VEHICLES, NAMELY, PASSENGER AUTOMOBILES, THEIR STRUCTURAL PARTS, TRIM AND BADGES (U.S. CLS. 19, 21, 23, 31, 35 AND 44).
FIRST USE 3-0-2010; IN COMMERCE 3-0-2010.

4,016,624. CHRYSLER GROUP LLC, AUBURN HILLS, MI. SN 77-948,635. PUB. 7-27-2010, FILED 3-2-2010.

NITRO HEAT

THE MARK CONSISTS OF STANDARD CHARACTERS WITHOUT CLAIM TO ANY PARTICULAR FONT, STYLE, SIZE, OR COLOR.
OWNER OF U.S. REG. NO. 3,262,240.
FOR MOTOR VEHICLES, NAMELY, PASSENGER AUTOMOBILES, THEIR STRUCTURAL PARTS, TRIM AND BADGES (U.S. CLS. 19, 21, 23, 31, 35 AND 44).
FIRST USE 4-0-2010; IN COMMERCE 4-0-2010.

4,016,727. SPECIALIZED BICYCLE COMPONENTS, INC., MORGAN HILL, CA. SN 85-002,458. PUB. 8-17-2010, FILED 3-30-2010.

VENGE

THE MARK CONSISTS OF STANDARD CHARACTERS WITHOUT CLAIM TO ANY PARTICULAR FONT, STYLE, SIZE, OR COLOR.
FOR BICYCLES AND BICYCLE FRAMES (U.S. CLS. 19, 21, 23, 31, 35 AND 44).
FIRST USE 3-16-2011; IN COMMERCE 4-19-2011.

CLASS 12—(Continued).

4,016,731. MCW LIMITED, KOWLOON,, HONG KONG. SN 85-003,815. PUB. 12-7-2010, FILED 4-1-2010.



THE MARK CONSISTS OF THE STYLIZED WORD "MY", WITH THE LETTER "Y" FORMING THE CENTRAL PART OF THE LETTER "M".

FOR HUB CAP COVERS; HUB CAPS; WHEEL HUBS FOR LAND VEHICLES, NAMELY, BICYCLES, AUTOMOBILES; WHEEL RIMS FOR VEHICLES; VEHICLE WHEEL RIMS AND STRUCTURAL PARTS; SUSPENSION SPRINGS FOR MOTOR CARS; SUSPENSION SYSTEMS FOR LAND VEHICLES, NAMELY, BICYCLES, AUTOMOBILES; TIRES FOR AUTOMOBILES; TIRES FOR VEHICLES; VEHICLE WHEELS; BALANCE WEIGHTS FOR VEHICLE WHEELS; SPOKE CLIPS FOR WHEEL, NAMELY, BICYCLE WHEELS, AUTOMOBILE WHEELS (U.S. CLS. 19, 21, 23, 31, 35 AND 44).
FIRST USE 1-1-2010; IN COMMERCE 1-1-2010.

4,016,781. HMS LIFT INC., ST. GEORGE, ONTARIO, CANADA. SN 85-026,718. PUB. 4-19-2011, FILED 4-29-2010.

BRUTE LIFT

THE MARK CONSISTS OF STANDARD CHARACTERS WITHOUT CLAIM TO ANY PARTICULAR FONT, STYLE, SIZE, OR COLOR.

NO CLAIM IS MADE TO THE EXCLUSIVE RIGHT TO USE "LIFT", APART FROM THE MARK AS SHOWN.

FOR INDUSTRIAL FORK LIFT TRUCKS FOR HEAVY LIFTING, NAMELY, FROM 40,000 LBS. TO 140,000 LBS. CAPACITY (U.S. CLS. 19, 21, 23, 31, 35 AND 44).
FIRST USE 7-6-2010; IN COMMERCE 7-6-2010.

CLASS 12—(Continued).

4,016,952. SUMMER INFANT (USA), INC., WOONSOCKET, RI. SN 85-073,800. PUB. 11-23-2010, FILED 6-29-2010.

Cushy Straps

THE MARK CONSISTS OF STANDARD CHARACTERS WITHOUT CLAIM TO ANY PARTICULAR FONT, STYLE, SIZE, OR COLOR.

NO CLAIM IS MADE TO THE EXCLUSIVE RIGHT TO USE "STRAPS", APART FROM THE MARK AS SHOWN.

FOR CUSHIONED STRAP COVERS FOR VEHICLE SEAT BELTS (U.S. CLS. 19, 21, 23, 31, 35 AND 44).
FIRST USE 4-0-2008; IN COMMERCE 4-0-2008.

4,017,011. XIAMEN ASON PRODUCTS CO., LTD, XIAMEN, CHINA. SN 85-089,156. PUB. 12-14-2010, FILED 7-21-2010.



THE MARK CONSISTS OF THE WORD "SWIFTCARBON" IN STYLIZED FONT.

FOR BICYCLE BRAKES; BICYCLE CHAINS; BICYCLE FRAMES; BICYCLE PARTS, NAMELY, DRIVE TRAINS; BICYCLE SADDLES; BICYCLES; HANDLEBARS; TIRES; WHEEL HUBS FOR BICYCLES; WHEEL RIMS (U.S. CLS. 19, 21, 23, 31, 35 AND 44).

FIRST USE 7-1-2009; IN COMMERCE 10-10-2010.

4,017,033. TAN-EI-SYA CO., LTD., TOYAMA 936-0036, JAPAN. SN 85-096,535. PUB. 1-11-2011, FILED 7-30-2010.

TWS

THE MARK CONSISTS OF STANDARD CHARACTERS WITHOUT CLAIM TO ANY PARTICULAR FONT, STYLE, SIZE, OR COLOR.

FOR VEHICLE ALLOY WHEELS, INCLUDING ALUMINUM OR MAGNESIUM WHEELS FOR VEHICLES (U.S. CLS. 19, 21, 23, 31, 35 AND 44).

FIRST USE 1-0-2010; IN COMMERCE 6-0-2011.

CLASS 12—(Continued).

4,017,135. BRAKE PARTS, INC., MCHENRY, IL. SN 85-136,753. PUB. 3-8-2011, FILED 9-23-2010.

R-300

THE MARK CONSISTS OF STANDARD CHARACTERS WITHOUT CLAIM TO ANY PARTICULAR FONT, STYLE, SIZE, OR COLOR.

FOR BRAKE ROTORS FOR LAND VEHICLES (U.S. CLS. 19, 21, 23, 31, 35 AND 44).

FIRST USE 10-0-2010; IN COMMERCE 10-0-2010.

4,017,229. KOLCRAFT ENTERPRISES, INC., CHICAGO, IL. SN 85-193,516. PUB. 4-19-2011, FILED 12-8-2010.

CONTOURS OPTIMA

THE MARK CONSISTS OF STANDARD CHARACTERS WITHOUT CLAIM TO ANY PARTICULAR FONT, STYLE, SIZE, OR COLOR.

OWNER OF U.S. REG. NO. 3,281,004.

FOR STROLLERS (U.S. CLS. 19, 21, 23, 31, 35 AND 44).

FIRST USE 4-22-2011; IN COMMERCE 4-22-2011.

CLASS 13—FIREARMS

4,016,528. ZARC INTERNATIONAL, INC., MINONK, IL. SN 77-905,486. PUB. 8-17-2010, FILED 1-5-2010.

POCKET GUARD

THE MARK CONSISTS OF STANDARD CHARACTERS WITHOUT CLAIM TO ANY PARTICULAR FONT, STYLE, SIZE, OR COLOR.

NO CLAIM IS MADE TO THE EXCLUSIVE RIGHT TO USE "POCKET", APART FROM THE MARK AS SHOWN.

FOR NON-LETHAL CHEMICAL SPRAY WEAPONS FOR PERSONAL DEFENSE (U.S. CLS. 2 AND 9).

FIRST USE 2-28-2010; IN COMMERCE 1-12-2011.

CLASS 13—(Continued).

4,016,844. CROSMAN CORPORATION, BLOOMFIELD, NY. SN 85-048,963. PUB. 10-26-2010, FILED 5-27-2010.

ROGUE

THE MARK CONSISTS OF STANDARD CHARACTERS WITHOUT CLAIM TO ANY PARTICULAR FONT, STYLE, SIZE, OR COLOR.

FOR AIR PISTOL BULLETS; AIR PISTOLS; AIR PISTOLS; AIR RIFLES; AIR SHOT; AIR SHOT OR PELLETS; AIRSOFT GUNS NOT FOR RECREATIONAL USE (U.S. CLS. 2 AND 9).

FIRST USE 1-18-2011; IN COMMERCE 1-28-2011.

CLASS 14—JEWELRY

4,016,172. KIMSAPRINCESS, INC., ENCINO, CA. SN 77-112,998. PUB. 8-14-2007, FILED 2-21-2007.

Kim Kardashian

THE MARK CONSISTS OF STANDARD CHARACTERS WITHOUT CLAIM TO ANY PARTICULAR FONT, STYLE, SIZE, OR COLOR.

FOR JEWELRY (U.S. CLS. 2, 27, 28 AND 50).

FIRST USE 10-0-2010; IN COMMERCE 10-0-2010.

4,016,455. MECHANICAL NATURE, LLC, COLUMBIA, SC. SN 77-880,743. PUB. 5-4-2010, FILED 11-25-2009.

MECHANICAL NATURE

THE MARK CONSISTS OF STANDARD CHARACTERS WITHOUT CLAIM TO ANY PARTICULAR FONT, STYLE, SIZE, OR COLOR.

NO CLAIM IS MADE TO THE EXCLUSIVE RIGHT TO USE "MECHANICAL", APART FROM THE MARK AS SHOWN.

FOR JEWELRY (U.S. CLS. 2, 27, 28 AND 50).

FIRST USE 2-16-2011; IN COMMERCE 2-16-2011.

CLASS 14—(Continued).

4,016,479. DIAMINTANGIBLES INTERNATIONAL, LTD., NASSAU, BAHAMAS. SN 77-889,487. PUB. 5-11-2010, FILED 12-9-2009.

WHERE THERE'S LOVE,
THERE'S FIRE

THE MARK CONSISTS OF STANDARD CHARACTERS WITHOUT CLAIM TO ANY PARTICULAR FONT, STYLE, SIZE, OR COLOR.
FOR JEWELRY (U.S. CLS. 2, 27, 28 AND 50).
FIRST USE 6-30-2011; IN COMMERCE 6-30-2011.

4,016,480. MY DIAMOND PLACE, LTD., NASSAU, BAHAMAS. SN 77-889,491. PUB. 5-11-2010, FILED 12-9-2009.

THE FIRE THAT NEVER FADES

THE MARK CONSISTS OF STANDARD CHARACTERS WITHOUT CLAIM TO ANY PARTICULAR FONT, STYLE, SIZE, OR COLOR.
FOR DIAMONDS; JEWELRY (U.S. CLS. 2, 27, 28 AND 50).
FIRST USE 6-28-2011; IN COMMERCE 6-28-2011.

4,016,487. STRANGE MUSIC, INC., BLUE SPRINGS, MO. SN 77-892,013. PUB. 5-4-2010, FILED 12-11-2009.

STRANGE MUSIC

THE MARK CONSISTS OF STANDARD CHARACTERS WITHOUT CLAIM TO ANY PARTICULAR FONT, STYLE, SIZE, OR COLOR.
FOR BODY JEWELRY; CHARMS; JEWELRY; JEWELRY CHAINS; JEWELRY AND IMITATION JEWELRY (U.S. CLS. 2, 27, 28 AND 50).
FIRST USE 5-18-2007; IN COMMERCE 5-18-2007.

CLASS 14—(Continued).

4,016,508. SCOTT KAY, INC., TEANECK, NJ. SN 77-896,289. PUB. 11-2-2010, FILED 12-17-2009.

BIOBLU 27

THE MARK CONSISTS OF STANDARD CHARACTERS WITHOUT CLAIM TO ANY PARTICULAR FONT, STYLE, SIZE, OR COLOR.
NO CLAIM IS MADE TO THE EXCLUSIVE RIGHT TO USE "27", APART FROM THE MARK AS SHOWN.
FOR JEWELRY MADE OF COBALT (U.S. CLS. 2, 27, 28 AND 50).
FIRST USE 12-0-2009; IN COMMERCE 12-0-2009.

4,016,509. SCOTT KAY, INC., TEANECK, NJ. SN 77-896,423. PUB. 11-23-2010, FILED 12-18-2009.

BRAWN COBALT

THE MARK CONSISTS OF STANDARD CHARACTERS WITHOUT CLAIM TO ANY PARTICULAR FONT, STYLE, SIZE, OR COLOR.
NO CLAIM IS MADE TO THE EXCLUSIVE RIGHT TO USE "COBALT", APART FROM THE MARK AS SHOWN.
FOR MEN'S WEDDING BANDS MADE OF COBALT (U.S. CLS. 2, 27, 28 AND 50).
FIRST USE 1-0-2011; IN COMMERCE 1-0-2011.

4,016,562. SKECHERS U.S.A., INC. II, MANHATTAN BEACH, CA. SN 77-922,905. PUB. 6-8-2010, FILED 1-28-2010.

TWINKLE TOES

THE MARK CONSISTS OF STANDARD CHARACTERS WITHOUT CLAIM TO ANY PARTICULAR FONT, STYLE, SIZE, OR COLOR.
OWNER OF U.S. REG. NO. 3,723,738.
FOR JEWELRY (U.S. CLS. 2, 27, 28 AND 50).
FIRST USE 12-1-2010; IN COMMERCE 12-1-2010.

CLASS 14—(Continued).

4,016,593. MUZO INTERNATIONAL LTD., GRAND CAYMAN, CAYMAN ISLANDS. SN 77-938,704. PUB. 4-12-2011, FILED 2-18-2010.



NO CLAIM IS MADE TO THE EXCLUSIVE RIGHT TO USE "MUZO", APART FROM THE MARK AS SHOWN.

THE COLOR(S) GREEN AND BLACK IS/ARE CLAIMED AS A FEATURE OF THE MARK.

THE MARK CONSISTS OF THE WORDING "MUZO" IN BLACK AND THE DESIGN OF A GREEN CIRCLE AND ARCH.

FOR EMERALDS; GEMSTONES; PRECIOUS STONES (U.S. CLS. 2, 27, 28 AND 50).

FIRST USE 5-6-2011; IN COMMERCE 5-6-2011.

4,016,785. SCISSOR HAPPY BY LZZY, LLC, WINDSOR, PA. SN 85-028,533. PUB. 10-19-2010, FILED 5-3-2010.

SCISSOR HAPPY BY LZZY

THE MARK CONSISTS OF STANDARD CHARACTERS WITHOUT CLAIM TO ANY PARTICULAR FONT, STYLE, SIZE, OR COLOR.

THE NAME SHOWN IN THE MARK IDENTIFIES ELIZABETH M. HALE, WHOSE CONSENT IS MADE OF RECORD.

FOR JEWELRY (U.S. CLS. 2, 27, 28 AND 50).

FIRST USE 6-14-2011; IN COMMERCE 6-14-2011.

4,016,845. BUZZBANDZ, LLC, STAFFORD, TX. SN 85-049,032. PUB. 11-2-2010, FILED 5-27-2010.

BUZZ BANDZ

THE MARK CONSISTS OF STANDARD CHARACTERS WITHOUT CLAIM TO ANY PARTICULAR FONT, STYLE, SIZE, OR COLOR.

NO CLAIM IS MADE TO THE EXCLUSIVE RIGHT TO USE "BANDS", APART FROM THE MARK AS SHOWN.

FOR RUBBER OR SILICON WRISTBANDS IN THE NATURE OF A BRACELET (U.S. CLS. 2, 27, 28 AND 50).

FIRST USE 9-0-2010; IN COMMERCE 9-0-2010.

CLASS 14—(Continued).

4,017,007. MIKE DALE JEWELERS, INC., MANDEVILLE, LA. SN 85-088,401. PUB. 1-18-2011, FILED 7-20-2010.

LAPEARLITE

THE MARK CONSISTS OF STANDARD CHARACTERS WITHOUT CLAIM TO ANY PARTICULAR FONT, STYLE, SIZE, OR COLOR.

FOR RETAIL STORE SERVICES AND ONLINE RETAIL STORE SERVICES FEATURING JEWELRY (U.S. CLS. 2, 27, 28 AND 50).

FIRST USE 4-15-2011; IN COMMERCE 4-15-2011.

4,017,138. NANETTE RUBEN LLC, DBA NANETTE RUBEN, FRISCO, TX. SN 85-137,342. PUB. 4-5-2011, FILED 9-24-2010.



THE NAME SHOWN IN THE MARK DOES NOT IDENTIFY A PARTICULAR LIVING INDIVIDUAL.

THE MARK CONSISTS OF "NANETTE RUBEN" AND THE STYLIZED LETTERS "NR".

FOR JEWELRY (U.S. CLS. 2, 27, 28 AND 50).

FIRST USE 2-1-2011; IN COMMERCE 2-1-2011.

4,017,178. KIM, SANG, LUBBOCK, TX. SN 85-162,155. PUB. 3-22-2011, FILED 10-27-2010.

MIND.BODY.ENERGY.BALANCE

THE MARK CONSISTS OF STANDARD CHARACTERS WITHOUT CLAIM TO ANY PARTICULAR FONT, STYLE, SIZE, OR COLOR.

FOR JEWELRY (U.S. CLS. 2, 27, 28 AND 50).

FIRST USE 2-0-2011; IN COMMERCE 2-0-2011.

CLASS 14—(Continued).

4,017,244. LANCECO INDUSTRIES, INC., DBA C.G. CREATIONS, PEARL RIVER, NY. SN 85-214,252. PUB. 5-17-2011, FILED 1-10-2011.

OMNI-LOK

THE MARK CONSISTS OF STANDARD CHARACTERS WITHOUT CLAIM TO ANY PARTICULAR FONT, STYLE, SIZE, OR COLOR.

FOR JEWELRY (U.S. CLS. 2, 27, 28 AND 50).
FIRST USE 2-15-2011; IN COMMERCE 2-15-2011.

CLASS 15—MUSICAL INSTRUMENTS

4,016,194. ERNIE BALL, INC., COACHELLA, CA. SN 77-256,505. PUB. 2-19-2008, FILED 8-16-2007.

BFR

THE MARK CONSISTS OF STANDARD CHARACTERS WITHOUT CLAIM TO ANY PARTICULAR FONT, STYLE, SIZE, OR COLOR.

FOR GUITARS AND PARTS THEREFORE (U.S. CLS. 2, 21 AND 36).
FIRST USE 5-9-2011; IN COMMERCE 5-9-2011.

4,016,919. GON BOPS INC., MARSHFIELD, MA. SN 85-067,541. PUB. 11-16-2010, FILED 6-21-2010.

PureCussion

THE MARK CONSISTS OF THE WORD "PURECUSSION" IN STYLIZED SCRIPT.

FOR PERCUSSION INSTRUMENTS, NAMELY, DRUMS, CLAVES, SHAKERS, TAMBOURINES (U.S. CLS. 2, 21 AND 36).
FIRST USE 1-0-2010; IN COMMERCE 1-0-2010.

CLASS 15—(Continued).

4,017,030. U.S. MUSIC CORPORATION, MUNDELEIN, IL. SN 85-095,935. PUB. 11-16-2010, FILED 7-29-2010.

MAXXFLY

THE MARK CONSISTS OF STANDARD CHARACTERS WITHOUT CLAIM TO ANY PARTICULAR FONT, STYLE, SIZE, OR COLOR.

OWNER OF U.S. REG. NOS. 1,803,720, 3,235,913, AND OTHERS.

FOR MUSICAL INSTRUMENTS, NAMELY, ELECTRIC GUITARS, ACOUSTIC GUITARS AND ELECTRIC BASS GUITARS (U.S. CLS. 2, 21 AND 36).

FIRST USE 10-1-2010; IN COMMERCE 10-1-2010.

4,017,146. RELIANCE INTERNATIONAL CORP., TAIPEI, TAIWAN. SN 85-143,410. PUB. 3-22-2011, FILED 10-1-2010.

PROONE

THE MARK CONSISTS OF A STYLIZED WORD "PROONE".

FOR MUSICAL INSTRUMENT ACCESSORIES, NAMELY, STANDS, CASES, CARRYING BAGS AND STORAGE BAGS; MUSICAL INSTRUMENTS, NAMELY, BRASS INSTRUMENTS, PERCUSSION INSTRUMENTS, STRING INSTRUMENTS, WIND INSTRUMENTS, CLARINETS, FLUTES, HORNS, TRUMPETS, TROMBONES, SAXOPHONES; ELECTRONIC MUSICAL KEYBOARDS; MOUTHPIECES FOR MUSICAL INSTRUMENTS; REEDS FOR USE IN WOODWIND MOUTHPIECES; SHEET MUSIC STANDS (U.S. CLS. 2, 21 AND 36).

FIRST USE 6-21-2011; IN COMMERCE 6-21-2011.

CLASS 16—PAPER GOODS AND PRINTED MATTER

CLASS 16—(Continued).

4,016,189. TRACEY L. ROBINSON, PLAINFIELD, NJ. SN 77-202,694. PUB. 4-22-2008, FILED 6-11-2007.

WADDLEWOZEN

THE MARK CONSISTS OF STANDARD CHARACTERS WITHOUT CLAIM TO ANY PARTICULAR FONT, STYLE, SIZE, OR COLOR.

FOR PRINTED MATTER, NAMELY, A SERIES OF FICTION BOOKS, CHILDREN'S BOOKS, COMIC BOOKS, COMIC STRIPS, CHILDREN'S COLORING BOOKS, AND ACTIVITY BOOKS (U.S. CLS. 2, 5, 22, 23, 29, 37, 38 AND 50).

FIRST USE 7-14-2011; IN COMMERCE 7-14-2011.

4,016,191. THE SAUL ZAENTZ COMPANY DBA TOLKIEN ENTERPRISES, BERKELEY, CA. SN 77-204,542. PUB. 4-22-2008, FILED 6-12-2007.

SMAUG

THE MARK CONSISTS OF STANDARD CHARACTERS WITHOUT CLAIM TO ANY PARTICULAR FONT, STYLE, SIZE, OR COLOR.

FOR TRADING CARDS (U.S. CLS. 2, 5, 22, 23, 29, 37, 38 AND 50).

FIRST USE 0-0-1995; IN COMMERCE 0-0-1995.

CLASS 16—(Continued).

4,016,267. MUTASIAN MEDIA, LLC, PALM BEACH GARDENS, FL. SN 77-481,676. PUB. 11-9-2010, FILED 5-22-2008.

GABBIE

THE MARK CONSISTS OF STANDARD CHARACTERS WITHOUT CLAIM TO ANY PARTICULAR FONT, STYLE, SIZE, OR COLOR.

FOR BOOKS IN THE FIELD OF CHILDREN'S THEMES FEATURING CARTOONS; CHILDREN'S BOOKS FEATURING WHIMSICAL CARTOON CHARACTERS; PLAYER'S GUIDE BOOKS RELATING TO CHILDREN'S CARTOON CHARACTERS IN THE FIELD OF VIDEO, TRADING CARDS, AND FANTASY GAMES; PAPER INSTRUCTIONAL AND TEACHING MATERIALS, PRINTED PUBLICATIONS, NAMELY, MAGAZINES OR JOURNALS, LEAFLETS, BROCHURES AND POSTERS, ALL IN THE FIELD OF CHILDREN'S THEMES AND ALL RELATING TO CHILDREN'S CARTOON CHARACTERS; PRINTED MATTER AND PUBLICATIONS, NAMELY, ADDRESS BOOKS, BOOK COVERS, BOOKMARKS, BOOKPLATES; CALENDARS; CHILDREN'S BOOKS; COLORING AND CHILDREN'S ACTIVITY BOOKS; COMIC BOOKS; MAGAZINES REGARDING VIDEO GAMES OR ONLINE GAMES; MAGNETIC WRITING SLATES, MEMO BOARDS MADE OF PAPER OR CARDBOARD OR WHITEBOARD, MEMO PADS, NEWSPAPER CARTOONS, NOTE PADS, NOTEBOOKS, PAPER BANNERS, PAPER PARTY DECORATIONS MOUNTABLE ON DOORS, PAPER NAPKINS, PAPER PARTY FAVORS, PAPER PLACE MATS, PAPER TABLE COVERS, PAPERBACK BOOKS IN THE FIELD OF CHILDREN'S THEMES, GIFT WRAPPING PAPER, GREETING CARDS, INVITATION CARDS, IRON-ON TRANSFERS; PICTURE STORYBOOKS, POSTCARDS, TRADING CARDS, POSTERS, THREE-RING BINDERS, RUBBER STAMPS, SCOREBOOKS, SCRAPBOOKS AND STAMP COLLECTOR BOOKS, SCRATCH PADS, STATIONERY, STATIONERY-TYPE PORTFOLIOS, STICKER ALBUMS, STICKERS; PENCIL BOXES, PENCIL SHARPENERS, PENCILS, PENS; STAPLERS; ARTIST BRUSHES, ARTISTS PASTELS, ART AND CRAFT PAINT KITS, CRAYONS; DECORATIVE FIGURES ATTACHABLE TO PENCILS; DRAWING RULERS; ERASERS, FELT-TIP MARKERS; AND GIFT BOXES (U.S. CLS. 2, 5, 22, 23, 29, 37, 38 AND 50).

FIRST USE 3-17-2009; IN COMMERCE 9-10-2009.

4,016,269. HALL, KATHLEEN A., CLARKESVILLE, GA. SN 77-490,286. PUB. 8-11-2009, FILED 6-4-2008.

**MINDFUL LIVING NETWORK
ENTERTAIN EDUCATE ENLIGHTEN**

THE MARK CONSISTS OF STANDARD CHARACTERS WITHOUT CLAIM TO ANY PARTICULAR FONT, STYLE, SIZE, OR COLOR.

CLASS 16—(Continued).

NO CLAIM IS MADE TO THE EXCLUSIVE RIGHT TO USE "MINDFUL LIVING", APART FROM THE MARK AS SHOWN.

FOR PRINTED MATERIALS, NAMELY, NEWSLETTERS, MAGAZINES, TEXTBOOKS, BOOKS, PAMPHLETS, BOOKLETS, TEACHING MATERIALS, INSPIRATIONAL CARDS, GREETING CARDS, NOTE CARDS, AND BLANK WRITING JOURNALS FOR PERSONAL REFLECTION, FEATURING PERSONAL SPIRITUAL GROWTH, HEALING AND WELLNESS, AND IDENTIFYING, OVERCOMING AND AVOIDING STRESS AND DESTRUCTIVE BEHAVIOR (U.S. CLS. 2, 5, 22, 23, 29, 37, 38 AND 50).

FIRST USE 8-8-2008; IN COMMERCE 8-8-2008.

4,016,286. MARVEL CHARACTERS, INC., MANHATTAN BEACH, CA. SN 77-620,501. PUB. 4-7-2009, FILED 11-24-2008.

SUPER- SOLDIER

THE MARK CONSISTS OF STANDARD CHARACTERS WITHOUT CLAIM TO ANY PARTICULAR FONT, STYLE, SIZE, OR COLOR.

FOR COMIC BOOKS; PRINTED PERIODICALS IN THE FIELD OF COMIC BOOK STORIES AND ARTWORK (U.S. CLS. 2, 5, 22, 23, 29, 37, 38 AND 50).

FIRST USE 7-7-2010; IN COMMERCE 7-7-2010.

4,016,323. FINEKIND FACTORY LLC, ISLAND LAKE, IL. SN 77-720,510. PUB. 1-19-2010, FILED 4-23-2009.



THE MARK CONSISTS OF THE TERM "FINEKIND" IN A STYLIZED FONT. IN PLACE OF THE DOTS OVER THE TWO LETTER "I'S IN THE TERM. THERE ARE SMALL FREE HAND CIRCLES DRAWN, WITH SMALL HORIZONTAL AND VERTICAL LINES RUNNING THROUGH THEM.

FOR ART PRINTS (U.S. CLS. 2, 5, 22, 23, 29, 37, 38 AND 50).

FIRST USE 3-1-2002; IN COMMERCE 8-15-2010.

CLASS 16—(Continued).

4,016,324. VILLAGE FOX, LAKELAND, TN. SN 77-723,558. PUB. 11-2-2010, FILED 4-27-2009.

Hot Flash Diva

THE MARK CONSISTS OF STANDARD CHARACTERS WITHOUT CLAIM TO ANY PARTICULAR FONT, STYLE, SIZE, OR COLOR.

FOR COMIC BOOKS; COMIC STRIPS APPEARING IN SYNDICATED PRESS, NAMELY, MAGAZINES AND NEWSPAPERS; GREETING CARDS; NEWSPAPER CARTOONS; STATIONERY; STORY BOOKS; GIFT BOOKS; COMIC BOOKS (U.S. CLS. 2, 5, 22, 23, 29, 37, 38 AND 50).

FIRST USE 10-1-2008; IN COMMERCE 10-1-2008.

4,016,445. KRUGER PRODUCTS L.P., MISSISSAUGA, ON, CANADA. SN 77-877,158. PUB. 4-20-2010, FILED 11-20-2009.

THE SMART ALTERNATIVE

THE MARK CONSISTS OF STANDARD CHARACTERS WITHOUT CLAIM TO ANY PARTICULAR FONT, STYLE, SIZE, OR COLOR.

FOR HYGIENIC PAPER PRODUCTS, NAMELY, BATHROOM TISSUE AND PAPER TOWELS (U.S. CLS. 2, 5, 22, 23, 29, 37, 38 AND 50).

FIRST USE 4-0-2010; IN COMMERCE 4-0-2010.

4,016,467. DECARAVA, SHERRY TURNER, BROOKLYN, NY. SN 77-885,644. PUB. 11-9-2010, FILED 12-3-2009.

ROY DECARAVA

THE MARK CONSISTS OF STANDARD CHARACTERS WITHOUT CLAIM TO ANY PARTICULAR FONT, STYLE, SIZE, OR COLOR.

FOR PRINTED PUBLICATIONS, NAMELY, BOOKS, NEWSLETTERS, PAMPHLETS IN THE FIELDS OF PAINTINGS, ART, PHOTOGRAPHS, PHOTOGRAPHY, MUSIC, HISTORY, AND BIOGRAPHIES OF FAMOUS PEOPLE; BOOKS IN THE FIELDS OF PAINTINGS, ART, PHOTOGRAPHS, PHOTOGRAPHY, MUSIC, HISTORY, AND BIOGRAPHIES OF FAMOUS PEOPLE; SERIGRAPHY; PHOTOGRAPHS; NOTE CARDS; AND POSTERS; EDUCATIONAL PUBLICATIONS, NAMELY, BOOKS IN THE FIELDS OF PAINTINGS, ART, PHOTOGRAPHS, PHOTOGRAPHY, MUSIC, HISTORY, AND BIOGRAPHIES OF FAMOUS PEOPLE (U.S. CLS. 2, 5, 22, 23, 29, 37, 38 AND 50).

FIRST USE 1-0-1996; IN COMMERCE 1-0-1996.

CLASS 16—(Continued).

4,016,506. A.T.X. INTERNATIONAL, INC., LINCOLN, RI. SN 77-895,941. PUB. 6-8-2010, FILED 12-17-2009.

SWITCH-IT

THE MARK CONSISTS OF STANDARD CHARACTERS WITHOUT CLAIM TO ANY PARTICULAR FONT, STYLE, SIZE, OR COLOR.

FOR WRITING INSTRUMENTS (U.S. CLS. 2, 5, 22, 23, 29, 37, 38 AND 50).

FIRST USE 3-1-2010; IN COMMERCE 3-1-2010.

4,016,566. KGP MEDIA LLC, DBA BUSTED! IN AUSTIN, AUSTIN, TX. SN 77-925,749. PUB. 6-15-2010, FILED 2-2-2010.

MUGLY!

THE MARK CONSISTS OF STANDARD CHARACTERS WITHOUT CLAIM TO ANY PARTICULAR FONT, STYLE, SIZE, OR COLOR.

FOR PRINTED PERIODICALS IN THE FIELD OF NATIONAL, STATE, AND LOCAL TRUE CRIME NEWS AND ENTERTAINMENT (U.S. CLS. 2, 5, 22, 23, 29, 37, 38 AND 50).

FIRST USE 2-1-2010; IN COMMERCE 2-1-2010.

4,016,638. AGC, LLC, CLEVELAND, OH. SN 77-955,697. PUB. 7-13-2010, FILED 3-10-2010.

PULL-EEZ

THE MARK CONSISTS OF THE WORDS "PULL" AND "EEZ" SEPARATED BY A DASH. THE FIRST LETTER "L" IN THE WORD "PULL" IS AN ARROW POINTING DOWN AND THE SECOND LETTER "L" IS AN ARROW POINTING UP.

FOR GREETING CARDS (U.S. CLS. 2, 5, 22, 23, 29, 37, 38 AND 50).

FIRST USE 4-30-2011; IN COMMERCE 4-30-2011.

CLASS 16—(Continued).

4,016,747. ENERGIE MEDIA GROUP, INC., CALABASAS, CA. SN 85-011,586. PUB. 9-14-2010, FILED 4-12-2010.

THE MARK CONSISTS OF THE LETTERS "CSQ" IN A STYLIZED FONT.

FOR MAGAZINES FEATURING ARTICLES AND ADVERTISEMENTS GEARED TOWARD BUSINESS LEADERS SUCH AS CEOs, COOS, AND CFOS; MAGAZINES IN THE FIELD OF BUSINESS, LUXURY AND LIFESTYLE; PRINTED PERIODICALS IN THE FIELD OF BUSINESS, LUXURY AND LIFESTYLE (U.S. CLS. 2, 5, 22, 23, 29, 37, 38 AND 50).

FIRST USE 2-15-2010; IN COMMERCE 2-15-2010.

4,016,762. I AM AMERICA BOOKS, LLC, SCOTTSDALE, AZ. SN 85-018,090. PUB. 9-21-2010, FILED 4-20-2010.



THE COLOR(S) RED, WHITE AND BLUE IS/ARE CLAIMED AS A FEATURE OF THE MARK.

THE MARK CONSISTS OF A WAVY BAR HAVING A BOX ON THE LEFT SIDE ENCLOSING A STAR.

FOR PUBLICATIONS, NAMELY, BOOKS PROVIDING PICTURES AND TEXT GLORIFYING AMERICA AND INDIVIDUAL STATES IN THE FIELDS OF EDUCATION (U.S. CLS. 2, 5, 22, 23, 29, 37, 38 AND 50).

FIRST USE 5-1-2011; IN COMMERCE 5-1-2011.

4,016,802. WHOLE FOODS MARKET IP, L.P., AUSTIN, TX. SN 85-036,309. PUB. 10-19-2010, FILED 5-12-2010.

HEALTH STARTS HERE

THE MARK CONSISTS OF STANDARD CHARACTERS WITHOUT CLAIM TO ANY PARTICULAR FONT, STYLE, SIZE, OR COLOR.

FOR PRINTED RECIPES SOLD AS A COMPONENT OF FOOD PACKAGING; PRINTED RECIPE CARDS; AND BROCHURES FEATURING RECIPES (U.S. CLS. 2, 5, 22, 23, 29, 37, 38 AND 50).

FIRST USE 6-0-2010; IN COMMERCE 6-0-2010.

CLASS 16—(Continued).

4,016,892. HARMONIX MUSIC SYSTEMS, INC., CAMBRIDGE, MA. SN 85-060,884. PUB. 11-9-2010, FILED 6-11-2010.

DANCE CENTRAL

THE MARK CONSISTS OF STANDARD CHARACTERS WITHOUT CLAIM TO ANY PARTICULAR FONT, STYLE, SIZE, OR COLOR.

FOR COMPUTER GAME INSTRUCTION MANUALS AND PUBLISHED GUIDES CONTAINING SUGGESTIONS ON HOW TO PLAY THE COMPUTER GAMES (U.S. CLS. 2, 5, 22, 23, 29, 37, 38 AND 50).

FIRST USE 11-4-2010; IN COMMERCE 11-4-2010.

CLASS 16—(Continued).

4,016,994. MYX, INC., PALM SPRINGS, CA. SN 85-084,288. PUB. 12-21-2010, FILED 7-14-2010.

TYM

THE MARK CONSISTS OF STANDARD CHARACTERS WITHOUT CLAIM TO ANY PARTICULAR FONT, STYLE, SIZE, OR COLOR.

FOR BINDERS FOR OFFICE USE; BLANK JOURNALS; BRAG BOOKS; CHECKBOOK COVERS; DESK BASKETS FOR DESK ACCESSORIES; DESK FILE TRAYS; DESK PADS; DESKTOP ORGANIZERS; DIARIES; DOCUMENT FILE TRAYS; DOCUMENT PORTFOLIOS; FABRIC GIFT BAGS; FILE BOXES FOR STORAGE OF BUSINESS AND PERSONAL RECORD; FILE BOXES FOR STORAGE OF MAGAZINES; FILE FOLDERS; GIFT BOXES; HAT BOXES OF CARDBOARD; HOLDERS FOR NOTEPADS; NOTE BOOKS; NOTE PADS; PAPER BAGS; PAPER BOXES; PASSPORT CASES; PASSPORT COVERS; PASSPORT HOLDERS; PERSONAL ORGANIZERS; PHOTO MATS; PHOTO STORAGE BOXES; PHOTOGRAPH ALBUMS; SCRAPBOOKS; STANDS FOR PENS AND PENCILS (U.S. CLS. 2, 5, 22, 23, 29, 37, 38 AND 50).

FIRST USE 5-14-2011; IN COMMERCE 5-14-2011.

4,016,997. USP LLC, OCEANSIDE, CA. SN 85-086,021. PUB. 12-14-2010, FILED 7-15-2010.

4,016,910. CHRISTIAN ART GIFTS, INC., LOMBARD, IL. SN 85-066,285. PUB. 12-28-2010, FILED 6-18-2010.

ENJOY LIFE



VERITAS GIFT
COMPANY

NO CLAIM IS MADE TO THE EXCLUSIVE RIGHT TO USE "GIFT COMPANY", APART FROM THE MARK AS SHOWN.

THE MARK CONSISTS OF THE WORDING "VERITAS GIFT COMPANY" IN A STYLIZED FONT.

FOR BIBLE COVERS (U.S. CLS. 2, 5, 22, 23, 29, 37, 38 AND 50).

FIRST USE 6-1-2011; IN COMMERCE 6-1-2011.

THE MARK CONSISTS OF STANDARD CHARACTERS WITHOUT CLAIM TO ANY PARTICULAR FONT, STYLE, SIZE, OR COLOR.

OWNER OF U.S. REG. NO. 2,647,126.

FOR PUBLICATIONS, NAMELY, SERIES OF MAGAZINES AND NEWSLETTERS IN THE FIELD OF HAIR CARE AND SKINCARE, INCLUDING TECHNICAL ADVICE FOR HAIR CARE AND SKIN CARE PROFESSIONALS, HAIR CARE AND SKIN CARE TRENDS, HAIR CARE AND SKIN CARE PRODUCT DESCRIPTIONS AND REVIEWS, HAIR CARE AND SKIN CARE SALON DESCRIPTIONS, STYLE MAKEOVERS, NEWS ABOUT THE HAIR CARE AND SKIN CARE INDUSTRY, HAIR CARE AND SKIN CARE BEST PRACTICES, AND HAIR CARE AND SKIN CARE PROFESSIONALS PROFILES AND REVIEWS AS WELL AS SOCIAL COMMENTARY ABOUT STYLE MAKEOVERS AND TRENDS, FASHION TRENDS, FOOD TRENDS, TRAVEL AND LIFESTYLE TRENDS (U.S. CLS. 2, 5, 22, 23, 29, 37, 38 AND 50).

FIRST USE 1-1-2011; IN COMMERCE 1-1-2011.

CLASS 16—(Continued).

4,017,000. NO TEARS LEARNING, INC., DBA HANDWRITING WITHOUT TEARS, CABIN JOHN, MD. SN 85-086,355. PUB. 12-28-2010, FILED 7-16-2010.

FLIP CRAYONS

THE MARK CONSISTS OF STANDARD CHARACTERS WITHOUT CLAIM TO ANY PARTICULAR FONT, STYLE, SIZE, OR COLOR.

NO CLAIM IS MADE TO THE EXCLUSIVE RIGHT TO USE "CRAYONS", APART FROM THE MARK AS SHOWN.

FOR CRAYONS SPECIALLY DESIGNED TO DEVELOP HAND COORDINATION AND FINE MOTOR SKILLS IN YOUNG CHILDREN (U.S. CLS. 2, 5, 22, 23, 29, 37, 38 AND 50).

FIRST USE 12-0-2006; IN COMMERCE 12-0-2006.

4,017,001. NO TEARS LEARNING, INC., DBA HANDWRITING WITHOUT TEARS, CABIN JOHN, MD. SN 85-086,397. PUB. 12-28-2010, FILED 7-16-2010.

STAMP AND SEE SCREEN

THE MARK CONSISTS OF STANDARD CHARACTERS WITHOUT CLAIM TO ANY PARTICULAR FONT, STYLE, SIZE, OR COLOR.

NO CLAIM IS MADE TO THE EXCLUSIVE RIGHT TO USE "SCREEN", APART FROM THE MARK AS SHOWN.

FOR EDUCATIONAL KITS CONSISTING PRIMARILY OF MAGNETIC SCREENS AND MAGNETIC STAMPS SOLD AS A UNIT WITH MAGNETIC WRITING PENS FOR TEACHING YOUNG CHILDREN TO TRACE AND WRITE LETTERS (U.S. CLS. 2, 5, 22, 23, 29, 37, 38 AND 50).

FIRST USE 10-15-2003; IN COMMERCE 10-15-2003.

4,017,028. JANE ELIZABETH PUBLISHING, INC., LOUISVILLE, KY. SN 85-093,594. PUB. 1-11-2011, FILED 7-27-2010.

Activate Love

THE MARK CONSISTS OF STANDARD CHARACTERS WITHOUT CLAIM TO ANY PARTICULAR FONT, STYLE, SIZE, OR COLOR.

FOR BOOKS IN THE FIELD OF SPIRITUALITY (U.S. CLS. 2, 5, 22, 23, 29, 37, 38 AND 50).

FIRST USE 1-1-2008; IN COMMERCE 1-1-2008.

CLASS 16—(Continued).

4,017,060. SPECIALTY PRODUCTS OF GREENWOOD, MISSOURI, INC., GREENWOOD, MO. SN 85-106,601. PUB. 2-1-2011, FILED 8-12-2010.

FLEXTECH

THE MARK CONSISTS OF STANDARD CHARACTERS WITHOUT CLAIM TO ANY PARTICULAR FONT, STYLE, SIZE, OR COLOR.

FOR PAINTING AND STAINING PADS FOR PAINT AND STAIN APPLICATORS (U.S. CLS. 2, 5, 22, 23, 29, 37, 38 AND 50).

FIRST USE 6-17-2010; IN COMMERCE 6-17-2010.

4,017,072. SERVICE COMPANY SOLUTIONS, LLC, BEDFORD, NH. SN 85-110,061. PUB. 1-25-2011, FILED 8-18-2010.

MASPG

THE MARK CONSISTS OF STANDARD CHARACTERS WITHOUT CLAIM TO ANY PARTICULAR FONT, STYLE, SIZE, OR COLOR.

FOR BOOKS IN THE FIELD OF APPLIANCE REPAIR (U.S. CLS. 2, 5, 22, 23, 29, 37, 38 AND 50).

FIRST USE 1-1-2010; IN COMMERCE 1-1-2010.

4,017,081. POLISHED PEARL GREETINGS INC, BURBANK, CA. SN 85-112,130. PUB. 3-22-2011, FILED 8-20-2010.

**C.C. Best ~ Sees the Best
in You**

THE MARK CONSISTS OF STANDARD CHARACTERS WITHOUT CLAIM TO ANY PARTICULAR FONT, STYLE, SIZE, OR COLOR.

THE NAME "C.C. BEST" DOES NOT IDENTIFY A LIVING INDIVIDUAL.

FOR BLANK JOURNALS; NOTE CARDS; NOTEPADS; POSTERS; SERIES OF FICTION BOOKS; STATIONERY; STICKERS (U.S. CLS. 2, 5, 22, 23, 29, 37, 38 AND 50).

FIRST USE 5-16-2011; IN COMMERCE 5-16-2011.

CLASS 16—(Continued).

4,017,089. THINK ART LLC, ARABI, LA. SN 85-115,562. PUB. 3-8-2011, FILED 8-25-2010.

THINK ART

THE MARK CONSISTS OF STANDARD CHARACTERS WITHOUT CLAIM TO ANY PARTICULAR FONT, STYLE, SIZE, OR COLOR.

NO CLAIM IS MADE TO THE EXCLUSIVE RIGHT TO USE "ART", APART FROM THE MARK AS SHOWN.

FOR ARTIST SUPPLIES, NAMELY, A HOLDER FOR ARTISTS' BRUSHES (U.S. CLS. 2, 5, 22, 23, 29, 37, 38 AND 50).

FIRST USE 1-1-2011; IN COMMERCE 1-1-2011.

4,017,099. KATE SPADE LLC, NEW YORK, NY. SN 85-120,107. PUB. 10-26-2010, FILED 8-31-2010.



kate spade
NEW YORK

OWNER OF U.S. REG. NOS. 2,446,491, 3,271,494, AND OTHERS.

NO CLAIM IS MADE TO THE EXCLUSIVE RIGHT TO USE "NEW YORK", APART FROM THE MARK AS SHOWN.

THE NAME "KATE SPADE" IDENTIFIES A LIVING INDIVIDUAL WHOSE CONSENT IS OF RECORD.

THE MARK CONSISTS OF A SPADE DESIGN WITH THE WORDS "KATE SPADE NEW YORK" UNDERNEATH.

FOR ADDRESS BOOKS; APPOINTMENT BOOKS; CALENDARS; INVITATION CARDS; NOTE CARDS; PERSONAL ORGANIZERS; STATIONERY (U.S. CLS. 2, 5, 22, 23, 29, 37, 38 AND 50).

FIRST USE 1-0-2011; IN COMMERCE 1-0-2011.

4,017,179. EK SUCCESS LTD., CLIFTON, NJ. SN 85-164,397. PUB. 4-12-2011, FILED 10-29-2010.

InkaDinkaClings Rubber Stamps that Cling

THE MARK CONSISTS OF STANDARD CHARACTERS WITHOUT CLAIM TO ANY PARTICULAR FONT, STYLE, SIZE, OR COLOR.

OWNER OF U.S. REG. NO. 1,165,529.

CLASS 16—(Continued).

NO CLAIM IS MADE TO THE EXCLUSIVE RIGHT TO USE "RUBBER STAMPS THAT CLING", APART FROM THE MARK AS SHOWN.

FOR IMPRESSION STAMPS; INK STAMPS; RUBBER STAMPS; STAMP STANDS (U.S. CLS. 2, 5, 22, 23, 29, 37, 38 AND 50).

FIRST USE 4-30-2011; IN COMMERCE 4-30-2011.

4,017,206. ELMER'S PRODUCTS, INC., WESTERVILLE, OH. SN 85-174,219. PUB. 4-26-2011, FILED 11-11-2010.



OWNER OF U.S. REG. NOS. 3,399,106, 3,772,498, AND OTHERS.

NO CLAIM IS MADE TO THE EXCLUSIVE RIGHT TO USE "PRECISION INSTRUMENTS", APART FROM THE MARK AS SHOWN.

THE COLOR(S) BLUE AND WHITE IS/ARE CLAIMED AS A FEATURE OF THE MARK.

THE MARK CONSISTS OF THE WORD "X ACTO" IN WHITE STYLIZED LETTERS. THE LETTERS "X" AND "A" ARE SEPARATED BY A WHITE DIAMOND DESIGN. THE WORDS "PRECISION INSTRUMENTS" APPEAR BELOW "X ACTO" IN WHITE STYLIZED LETTERS. BEHIND THE WORDS "X ACTO" AND "PRECISION INSTRUMENTS" IS A DIAMOND DESIGN IN CASCADING SHADES OF BLUE FROM LIGHT BLUE TO NAVY BLUE.

FOR ELECTRIC PENCIL SHARPENERS (U.S. CLS. 2, 5, 22, 23, 29, 37, 38 AND 50).

FIRST USE 2-1-2011; IN COMMERCE 2-1-2011.

4,017,255. FOX FACTORY, INC., WATSONVILLE, CA. SN 85-975,399. PUB. 9-28-2010, FILED 4-27-2010.

WHEN IT COUNTS

THE MARK CONSISTS OF STANDARD CHARACTERS WITHOUT CLAIM TO ANY PARTICULAR FONT, STYLE, SIZE, OR COLOR.

FOR PAPER GOODS AND PRINTED MATTER, NAMELY, POSTERS, LEAFLETS, BROCHURES, STICKERS, AND BANNERS RELATED TO SHOCK ABSORBERS FOR VEHICLES (U.S. CLS. 2, 5, 22, 23, 29, 37, 38 AND 50).

FIRST USE 4-15-2010; IN COMMERCE 4-15-2010.

CLASS 17—RUBBER GOODS

CLASS 17—(Continued).

4,016,748. 3M COMPANY, ST. PAUL, MN. SN 85-012,383. PUB. 11-9-2010, FILED 4-13-2010.

FASARA

THE MARK CONSISTS OF STANDARD CHARACTERS WITHOUT CLAIM TO ANY PARTICULAR FONT, STYLE, SIZE, OR COLOR.

FOR DECORATIVE PLASTIC FILM FOR USE ON INTERIOR AND EXTERIOR GLASS, WINDOWS AND GLASS PARTITIONS (U.S. CLS. 1, 5, 12, 13, 35 AND 50). FIRST USE 1-4-2005; IN COMMERCE 1-4-2005.

4,016,759. GOLDSTEIN, IRA, RALEIGH, NC. AND GOLDSTEIN, DAVID, RALEIGH, NC. SN 85-016,923. PUB. 12-21-2010, FILED 4-19-2010.

ezARTshipper

THE MARK CONSISTS OF STANDARD CHARACTERS WITHOUT CLAIM TO ANY PARTICULAR FONT, STYLE, SIZE, OR COLOR.

FOR PROTECTIVE PACKAGING FOR SHIPPING AND TRANSPORTING FRAMED AND UNFRAMED ART AND MIRRORS, NAMELY, CORRUGATED PACKAGING AND SHIPPING BUFFERS FOR PHYSICAL PROTECTION OF ITEMS DURING SHIPPING (U.S. CLS. 1, 5, 12, 13, 35 AND 50).

FIRST USE 6-26-2011; IN COMMERCE 6-26-2011.

4,017,092. ADVANCE PRODUCTS & SYSTEMS, INC., SCOTT, LA. SN 85-117,389. PUB. 2-8-2011, FILED 8-27-2010.

Voltaccept

THE MARK CONSISTS OF STANDARD CHARACTERS WITHOUT CLAIM TO ANY PARTICULAR FONT, STYLE, SIZE, OR COLOR.

FOR PIPE GASKETS (U.S. CLS. 1, 5, 12, 13, 35 AND 50). FIRST USE 2-10-2011; IN COMMERCE 2-10-2011.

CLASS 18—LEATHER GOODS

CLASS 18—(Continued).

4,016,171. THOMAS C. FORD, AUSTIN, TX. SN 77-112,703. PUB. 9-4-2007, FILED 2-21-2007.

TF

THE MARK CONSISTS OF THE INITIALS "TF". FOR TOTE BAGS, TRAVEL BAGS, OVERNIGHT BAGS AND WALLETS (U.S. CLS. 1, 2, 3, 22 AND 41). FIRST USE 9-15-2009; IN COMMERCE 9-15-2009.

4,016,221. CONSOLIDATED SHOE COMPANY, INC., LYNCHBURG, VA. SN 77-335,281. PUB. 4-15-2008, FILED 11-21-2007.

DIMMI

THE MARK CONSISTS OF STANDARD CHARACTERS WITHOUT CLAIM TO ANY PARTICULAR FONT, STYLE, SIZE, OR COLOR.

THE FOREIGN WORDING IN THE MARK TRANSLATES INTO ENGLISH AS TELL ME.

FOR BAGS, NAMELY, BEACH BAGS, BOOK BAGS, CARRY-ALL BAGS, SHOULDER BAGS, SCHOOL BAGS, SCHOOL-BOOK BAGS, TEXTILE SHOPPING BAGS, TOTE BAGS, CANVAS SHOPPING BAGS (U.S. CLS. 1, 2, 3, 22 AND 41).

FIRST USE 6-28-2011; IN COMMERCE 6-28-2011.

4,016,319. GUCCI AMERICA, INC., NEW YORK, NY. SN 77-705,112. PUB. 9-29-2009, FILED 4-2-2009.

NEW JACKIE

THE MARK CONSISTS OF STANDARD CHARACTERS WITHOUT CLAIM TO ANY PARTICULAR FONT, STYLE, SIZE, OR COLOR.

CLASS 18—(Continued).

THE NAME(S), PORTRAIT(S), AND/OR SIGNATURE(S) SHOWN IN THE MARK DOES NOT IDENTIFY A PARTICULAR LIVING INDIVIDUAL.

FOR SHOULDER BAGS, PURSES, HANDBAGS, TOTE BAGS, PARTLY AND WHOLLY OF LEATHER (U.S. CLS. 1, 2, 3, 22 AND 41).

FIRST USE 4-1-2009; IN COMMERCE 4-1-2009.

4,016,485. MARVEL CHARACTERS, INC., MANHATTAN BEACH, CA. SN 77-891,602. PUB. 10-26-2010, FILED 12-11-2009.

THOR

THE MARK CONSISTS OF STANDARD CHARACTERS WITHOUT CLAIM TO ANY PARTICULAR FONT, STYLE, SIZE, OR COLOR.

OWNER OF U.S. REG. NOS. 890,918, 958,186, AND 2,933,886.

FOR BACKPACKS; BOOK BAGS; KNAPSACKS; SCHOOL BAGS; SCHOOL BOOK BAGS; UMBRELLAS (U.S. CLS. 1, 2, 3, 22 AND 41).

FIRST USE 4-15-2011; IN COMMERCE 4-15-2011.

4,016,531. INFANTINO, LLC, SAN DIEGO, CA. SN 77-907,353. PUB. 6-1-2010, FILED 1-7-2010.

SASH

THE MARK CONSISTS OF STANDARD CHARACTERS WITHOUT CLAIM TO ANY PARTICULAR FONT, STYLE, SIZE, OR COLOR.

FOR INFANT CARRIERS WORN ON THE BODY (U.S. CLS. 1, 2, 3, 22 AND 41).

FIRST USE 12-29-2010; IN COMMERCE 12-29-2010.

4,016,544. ON OPTIMUM NUTRITION LIMITED, KILKENNY CITY, IRELAND. SN 77-913,993. PUB. 6-1-2010, FILED 1-18-2010.



OWNER OF U.S. REG. NOS. 2,811,132, 3,114,540, AND OTHERS.

CLASS 18—(Continued).

NO CLAIM IS MADE TO THE EXCLUSIVE RIGHT TO USE "PERFORMANCE", APART FROM THE MARK AS SHOWN.

THE MARK CONSISTS OF THE IMAGE OF AN EAGLE AND THE LETTERS, "ABB" FOLLOWED BY THE WORD, "PERFORMANCE".

FOR GYM BAGS (U.S. CLS. 1, 2, 3, 22 AND 41).

FIRST USE 9-1-2010; IN COMMERCE 9-1-2010.

4,016,749. KAIZEN ENTERPRISES, INC., FRANKFORT, IL. SN 85-012,634. PUB. 11-23-2010, FILED 4-13-2010.



THE MARK CONSISTS OF THE WORDS "POOPY POCKETS.COM" WITH AN IMAGE OF A DOG BETWEEN THE "S" IN "POCKETS" AND THE PERIOD IN ".COM".

FOR PET ACCESSORIES, NAMELY, CLOTH, CANVAS, OR VINYL BAGS ATTACHED TO ANIMAL LEASHES FOR USE IN HOLDING DISPOSABLE BAGS AND DISPOSABLE BAGS CONTAINING PET WASTE SOLD AS A UNIT (U.S. CLS. 1, 2, 3, 22 AND 41).

FIRST USE 6-24-2011; IN COMMERCE 6-24-2011.

4,016,888. BOWMAN, TERRY, MADISON, NC. AND BOWMAN, ELVINA, MADISON, NC. SN 85-060,529. PUB. 11-9-2010, FILED 6-11-2010.



THE MARK CONSISTS OF THE STYLIZED WORDS "POO CHAE'". AN IMAGE OF A DOG PAW PRINT IN BETWEEN THE TWO WORDS.

FOR DOG CLOTHING; DOG COLLARS AND LEADS; DOG LEASHES; DOG SHOES; POUCHES USED TO CARRYING SMALL DOGS (U.S. CLS. 1, 2, 3, 22 AND 41).

FIRST USE 2-15-2011; IN COMMERCE 4-15-2011.

CLASS 18—(Continued).

4,016,890. L & LEUNG HANDBAGS MFY. LTD., NEW TERRITORIES, HONG KONG. SN 85-060,816. PUB. 11-16-2010, FILED 6-11-2010.



THE MARK CONSISTS OF THE STYLIZED WORDING "SACK" FOLLOWED BY A CURVED ARROW AND A DESIGN OF A BAG ABOVE THE STYLIZED WORDING "SWAP".

FOR HANDBAGS; WALLETS; COIN PURSES; CARD-HOLDERS, NAMELY, CARD WALLETS, BUSINESS CARD CASES, CALLING CARD CASES, CREDIT CARD CASES (U.S. CLS. 1, 2, 3, 22 AND 41).

FIRST USE 5-11-2010; IN COMMERCE 5-11-2010.

4,016,944. LABORATORIOS DE MODA S.A. DE C.V, LEÓN, GUANAJUATO, MEXICO. SN 85-071,895. PUB. 11-16-2010, FILED 6-25-2010.



CORAZÓN DE MELÓN

THE MARK CONSISTS OF AN ABSTRACT DESIGN WHOSE UPPER AREA LOOKS LIKE A HEART AND WHOSE LOWER AREA LOOKS LIKE A STYLIZED CAPITAL LETTER "M". THE DESIGN CONTAINS ADDITIONAL ABSTRACT DECORATIVE ELEMENTS. BENEATH THE DESIGN APPEAR THE WORDS "CORAZÓN DE MELÓN" IN STYLIZED LETTERS.

THE LITERAL TRANSLATION OF THE SPANISH PHRASE "CORAZÓN DE MELÓN" IS "HEART OF MELON". THIS IS A TERM OF ENDEARMENT IN SPANISH.

FOR BILLFOLDS; BRIEFCASES; CHANGE PURSES; DOCUMENT SUITCASES; HANDBAGS; LUGGAGE; POCKET WALLETS; PURSES; SMALL SUITCASES; SUITCASES; TRAVEL BAGS; WALLETS (U.S. CLS. 1, 2, 3, 22 AND 41).

FIRST USE 1-26-2006; IN COMMERCE 9-2-2009.

CLASS 18—(Continued).

4,016,990. ALTO OF SOUTH FLORIDA, INC., PLANTATION, FL. SN 85-083,474. PUB. 12-14-2010, FILED 7-13-2010.

PUP CRAWL

THE MARK CONSISTS OF STANDARD CHARACTERS WITHOUT CLAIM TO ANY PARTICULAR FONT, STYLE, SIZE, OR COLOR.

FOR PET SUPPLIES, NAMELY, LEASHES, COLLARS AND TAGS (U.S. CLS. 1, 2, 3, 22 AND 41).

FIRST USE 1-24-2011; IN COMMERCE 1-24-2011.

CLASS 19—NON-METALLIC BUILDING MATERIALS

4,016,315. FAIRFIELD STONE & LANDSCAPE SUPPLY, LLC, FAIRFIELD, CT. SN 77-696,530. PUB. 1-5-2010, FILED 3-23-2009.

THINSTONES • REAL STONE • REAL THIN • REAL SIMPLE

NO CLAIM IS MADE TO THE EXCLUSIVE RIGHT TO USE "THIN STONES" AND "REAL STONE", APART FROM THE MARK AS SHOWN.

THE MARK CONSISTS OF THE WORDS "THINSTONES REAL STONE REAL THIN REAL SIMPLE". A CIRCLE APPEARS BETWEEN THE WORDING "THINSTONES" AND "REAL STONE", BETWEEN THE WORDING "REAL STONE" AND "REAL THIN" AND BETWEEN THE WORDING "REAL THIN" AND "REAL SIMPLE".

FOR STONE FOR BUILDING AND CONSTRUCTION (U.S. CLS. 1, 12, 33 AND 50).

FIRST USE 3-31-2009; IN COMMERCE 3-31-2009.

4,016,356. U.S. PLY, INC., PORT ARTHUR, TX. SN 77-760,107. PUB. 5-11-2010, FILED 6-15-2009.

DURASTAR

THE MARK CONSISTS OF STANDARD CHARACTERS WITHOUT CLAIM TO ANY PARTICULAR FONT, STYLE, SIZE, OR COLOR.

FOR ROOFING PRODUCTS IN THE NATURE OF ROOFING MEMBRANES, NAMELY, ATACTIC POLY-PROPYLENE MODIFIED BITUMEN-BASED ROLL ROOFING FOR USE AS A CAP MEMBRANE ON MODIFIED BITUMEN AND HYBRID BUILT-UP ROOF SYSTEMS AND HAVING A REFLECTIVE COATING TO PROTECT THE INTEGRITY OF THE MEMBRANE (U.S. CLS. 1, 12, 33 AND 50).

FIRST USE 8-10-2009; IN COMMERCE 8-10-2009.

CLASS 19—(Continued).

4,016,416. DOREL JUVENILE GROUP, INC., FOXBORO, MA.
SN 77-845,752. PUB. 10-12-2010, FILED 10-9-2009.



OWNER OF U.S. REG. NOS. 1,619,413, 2,959,314, AND OTHERS.

THE MARK CONSISTS OF THE WORD "SAFETY" FOLLOWED BY "1ST" WHICH IS ENCOMPASSED WITHIN A DIAMOND DESIGN, ABOVE THE WORD "NATURE" WHICH IS ABOVE A RECTANGLE-LIKE SHADED BORDER CONTAINING THE WORD "NEXT" AND THE DESIGN OF A LEAF TO THE RIGHT.

FOR NON-METAL GATES (U.S. CLS. 1, 12, 33 AND 50).
FIRST USE 0-0-2009; IN COMMERCE 0-0-2009.

4,016,453. FLORIDA HOME-IMPROVEMENT ASSOCIATES, INC., HOLLYWOOD, FL. SN 77-879,646. PUB. 8-31-2010, FILED 11-24-2009.



NO CLAIM IS MADE TO THE EXCLUSIVE RIGHT TO USE "SOLAR", APART FROM THE MARK AS SHOWN.

THE COLOR(S) LIGHT YELLOW-GREEN, GREEN, DARK GREEN, BLUE, AND WHITE IS/ARE CLAIMED AS A FEATURE OF THE MARK.

THE MARK CONSISTS OF THE FOLLOWING: THE WORDS "SOLAR MAX" WITH THE LETTERS OUTLINED IN A DARK GREEN AND FILLED WITH A GRADUATED LIGHT YELLOW-GREEN TO GREEN TO DARK GREEN FROM BOTTOM TO TOP. THE LETTER "O" IN "SOLAR" CONTAINS A TERRESTRIAL GLOBE WITH CONTINENTS IN YELLOW-GREEN, GREEN AND DARK GREEN, OCEANS IN BLUE, AND CLOUDS IN WHITE AND THREE STARBURST REFLECTIONS IN WHITE.

FOR GLASS PANES FOR REPLACEMENT WINDOWS; WINDOW GLASS EXCEPT GLASS FOR VEHICLE WINDOWS; GLASS IN COMBINATION WITH METAL AND NON-METAL ELEMENTS, NAMELY, FRAMES, USED FOR BUILDING; GLASS FOR DOORS AND WINDOWS (U.S. CLS. 1, 12, 33 AND 50).

FIRST USE 11-2-2010; IN COMMERCE 11-2-2010.

CLASS 19—(Continued).

4,016,721. STANTON ADVANCED CERAMICS, INC., CLEVELAND, OH. SN 78-881,412. PUB. 11-27-2007, FILED 5-11-2006.

FIRESLAYER

THE MARK CONSISTS OF STANDARD CHARACTERS WITHOUT CLAIM TO ANY PARTICULAR FONT, STYLE, SIZE, OR COLOR.

FOR REINFORCED CERAMIC SHAPES, BLOCKS, PARTICLES, MORTAR AND PATCHING MATERIAL, FOR USE IN REFRACTORY APPLICATIONS (U.S. CLS. 1, 12, 33 AND 50).

FIRST USE 2-2-2010; IN COMMERCE 2-2-2010.

4,016,899. COLUMBIA INSURANCE COMPANY, OMAHA, NE. SN 85-063,428. PUB. 11-16-2010, FILED 6-15-2010.

OPTIEND

THE MARK CONSISTS OF STANDARD CHARACTERS WITHOUT CLAIM TO ANY PARTICULAR FONT, STYLE, SIZE, OR COLOR.

FOR HARDWOOD FLOORING (U.S. CLS. 1, 12, 33 AND 50).

FIRST USE 6-0-2010; IN COMMERCE 6-0-2010.

4,017,157. CLEARWATER PAPER CORPORATION, SPOKANE, WA. SN 85-150,987. PUB. 4-19-2011, FILED 10-12-2010.

CedarMark

THE MARK CONSISTS OF STANDARD CHARACTERS WITHOUT CLAIM TO ANY PARTICULAR FONT, STYLE, SIZE, OR COLOR.

FOR CEDAR LUMBER (U.S. CLS. 1, 12, 33 AND 50).
FIRST USE 10-13-2010; IN COMMERCE 10-13-2010.

CLASS 19—(Continued).

4,017,164. STUDIO5051, LLC, DBA STUDIO5051, MINNEAPOLIS, MN. SN 85-155,113. PUB. 4-5-2011, FILED 10-18-2010.

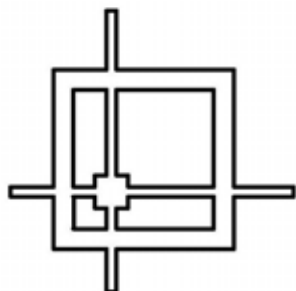

THE MARK CONSISTS OF A DESIGN CONTAINING TWO INTERCONNECTED, DIFFERENTLY SIZED SQUARES, ONE HOUSED WITHIN THE OTHER, WHEREIN A SMALL SQUARE IS FRAMED BY A LARGER SQUARE AND IS LOCATED IN THE LOWER LEFT CORNER OF THE LARGER SQUARE, AND WHEREIN FURTHER THE LARGE SQUARE HAS A BORDER CONSISTING OF TWO THIN PARALLEL LINES THAT FORM A FRAME, AND THE PERIMETER OF THE SMALL SQUARE CONSISTS OF A SINGLE LINE THAT IS BROKEN ON EACH SIDE OF ITS FOUR SIDES AND FROM WHERE A PAIR OF PARALLEL LINES EMANATES FROM EACH OF THE SMALLER SQUARE'S FOUR SIDES AT 90 DEGREE ANGLES, THOSE PARALLEL LINES EXTENDING AND INTERSECTING THE PERIMETER OF THE LARGER SQUARE AT 90 DEGREE ANGLES.

FOR CONCRETE BUILDING MATERIALS, NAMELY, PAVERS, WALL BLOCKS (U.S. CLS. 1, 12, 33 AND 50).
FIRST USE 11-15-2010; IN COMMERCE 2-15-2011.

CLASS 20—FURNITURE AND ARTICLES NOT OTHERWISE CLASSIFIED

4,016,196. ROBERTS, JONATHAN, FRISCO, TX. SN 77-264,369. PUB. 6-3-2008, FILED 8-25-2007.

UPPERcase

THE MARK CONSISTS OF STANDARD CHARACTERS WITHOUT CLAIM TO ANY PARTICULAR FONT, STYLE, SIZE, OR COLOR.

FOR MODULAR OVERHEAD STORAGE AND ORGANIZATION SYSTEMS COMPRISING CABINETS AND BINS, SOLD AS A UNIT (U.S. CLS. 2, 13, 22, 25, 32 AND 50).

FIRST USE 8-3-2010; IN COMMERCE 8-3-2010.

CLASS 20—(Continued).

4,016,378. JORDAN DREW CORPORATION, TARRYTOWN, NY. SN 77-796,388. PUB. 11-23-2010, FILED 8-4-2009.

Home Smart Dryer Maid

THE MARK CONSISTS OF STANDARD CHARACTERS WITHOUT CLAIM TO ANY PARTICULAR FONT, STYLE, SIZE, OR COLOR.

NO CLAIM IS MADE TO THE EXCLUSIVE RIGHT TO USE "DRYER", APART FROM THE MARK AS SHOWN.
FOR NON-METAL DRYER BALLS SOLD EMPTY USED TO REMOVE LINT (U.S. CLS. 2, 13, 22, 25, 32 AND 50).

FIRST USE 8-13-2010; IN COMMERCE 8-13-2010.

4,016,379. JORDAN DREW CORPORATION, TARRYTOWN, NY. SN 77-796,579. PUB. 11-23-2010, FILED 8-4-2009.

Dryer Maid

THE MARK CONSISTS OF STANDARD CHARACTERS WITHOUT CLAIM TO ANY PARTICULAR FONT, STYLE, SIZE, OR COLOR.

NO CLAIM IS MADE TO THE EXCLUSIVE RIGHT TO USE "DRYER", APART FROM THE MARK AS SHOWN.
FOR NON-METAL DRYER BALLS SOLD EMPTY USED TO REMOVE LINT (U.S. CLS. 2, 13, 22, 25, 32 AND 50).

FIRST USE 8-13-2010; IN COMMERCE 8-13-2010.

4,016,395. COBRA FIXATIONS CIE LTEE, MONTREAL, QUEBEC, CANADA. SN 77-819,613. PUB. 7-20-2010, FILED 9-3-2009.

XPRESS INTELLIGENT HANGERS

THE MARK CONSISTS OF STANDARD CHARACTERS WITHOUT CLAIM TO ANY PARTICULAR FONT, STYLE, SIZE, OR COLOR.

PRIORITY CLAIMED UNDER SEC. 44(D) ON CANADA APPLICATION NO. 1449565, FILED 8-26-2009.

NO CLAIM IS MADE TO THE EXCLUSIVE RIGHT TO USE "HANGERS", APART FROM THE MARK AS SHOWN.

FOR NON-METAL FASTENING HOOKS AND ANCHORS FOR USE IN GYPSUM PANELS, DRYWALL, PLASTER BOARDS, WOOD PANELS AND HOLLOWED DOORS (U.S. CLS. 2, 13, 22, 25, 32 AND 50).

FIRST USE 10-0-2009; IN COMMERCE 10-0-2009.

CLASS 20—(Continued).

4,016,466. BATESVILLE SERVICES, INC., BATESVILLE, IN.
SN 77-885,413. PUB. 4-27-2010, FILED 12-3-2009.

CAPTURED MOMENTS

THE MARK CONSISTS OF STANDARD CHARACTERS WITHOUT CLAIM TO ANY PARTICULAR FONT, STYLE, SIZE, OR COLOR.

FOR CREMATION URNS (U.S. CLS. 2, 13, 22, 25, 32 AND 50).

FIRST USE 1-0-2010; IN COMMERCE 1-0-2010.

4,016,533. ALL WOOD CABINETRY, LLC, NORTH PALM BEACH, FL. SN 77-908,114. PUB. 5-11-2010, FILED 1-8-2010.



THE MARK CONSISTS OF THE STYLIZED PRESENTATION OF THE WORD "FAST" ABOVE THE WORDS "RIGHT AND ON TIME, THE FIRST TIME!!!" IN BLOCK LETTERS.

FOR FURNITURE, NAMELY, KITCHEN CABINETS, BATHROOM VANITIES, CABINET HARDWARE AND COUNTERTOPS (U.S. CLS. 2, 13, 22, 25, 32 AND 50).

FIRST USE 1-15-2010; IN COMMERCE 1-15-2010.

4,016,538. KELLY, DANIEL, MEDFORD, NJ. SN 77-909,356.
PUB. 5-25-2010, FILED 1-11-2010.

BOTTLE-UP

THE MARK CONSISTS OF STANDARD CHARACTERS WITHOUT CLAIM TO ANY PARTICULAR FONT, STYLE, SIZE, OR COLOR.

FOR DISPLAY RACKS; STORAGE RACKS (U.S. CLS. 2, 13, 22, 25, 32 AND 50).

FIRST USE 5-9-2009; IN COMMERCE 5-9-2009.

CLASS 20—(Continued).

4,016,541. SUMMER CLASSICS, INC., MONTEVALLO, AL.
SN 77-911,490. PUB. 5-25-2010, FILED 1-13-2010.

GABBY

THE MARK CONSISTS OF STANDARD CHARACTERS WITHOUT CLAIM TO ANY PARTICULAR FONT, STYLE, SIZE, OR COLOR.

FOR MIRRORS, FURNITURE, SCULPTURES OF PLASTIC RESIN (U.S. CLS. 2, 13, 22, 25, 32 AND 50).

FIRST USE 1-29-2010; IN COMMERCE 1-29-2010.

4,016,587. LIGHTHOUSE DISPLAY INTERNATIONAL LTD., NOTTINGHAM, GREAT BRITAIN. SN 77-936,363. PUB. 1-25-2011, FILED 2-16-2010.



NO CLAIM IS MADE TO THE EXCLUSIVE RIGHT TO USE "DISPLAY" AND "INTERNATIONAL", APART FROM THE MARK AS SHOWN.

THE MARK CONSISTS OF AN IMAGE OF A LIGHTHOUSE WITH THREE BIRDS FLYING BESIDE IT WITH THE WORDS "LIGHTHOUSE DISPLAY INTERNATIONAL" THEREON.

FOR ADVERTISING DISPLAY BOARDS OF CARDBOARD, PAPER OR PLASTICS; DISPLAY STANDS; DISPLAY BOARDS; SALES DISPLAY STANDS; POINT-OF-SALE PRICE DISPLAYS; ADVERTISING DISPLAY BOARDS; DISPLAY STANDS; PORTABLE UPRIGHT DISPLAY STANDS; MULTI-PURPOSE DISPLAY STANDS; NONMETAL HOLDERS FOR SIGNS; DISPLAY BOARDS USED TO HOLD LABELS; MULTIPLE PLASTIC HOOKS ON A COMMON STRIP FOR SUSPENDING DISPLAY MATERIAL, PRODUCTS FOR SALE, SIGNS, LABELS AND LEAFLETS; DISPLAY CASES FOR MERCHANDISE (U.S. CLS. 2, 13, 22, 25, 32 AND 50).

FIRST USE 12-31-1999; IN COMMERCE 11-30-2001.

CLASS 20—(Continued).

4,016,756. BETTER METAL, LLC, LA VERGNE, TN. SN 85-014,747. PUB. 3-8-2011, FILED 4-15-2010.



THE MARK CONSISTS OF CIRCLE SHAPE THAT CONTAINS THE PHRASE "SLB" IN ALL CAPS.
 FOR NON-METAL HARDWARE, NAMELY, PLASTIC BLOCK HANGERS FOR THE PURPOSE OF SUPPORTING COAXIAL CABLE (U.S. CLS. 2, 13, 22, 25, 32 AND 50).
 FIRST USE 2-0-2011; IN COMMERCE 2-0-2011.

4,016,782. WING ENTERPRISES, INC., SPRINGVILLE, UT. SN 85-027,636. PUB. 4-26-2011, FILED 4-30-2010.

SUMO

THE MARK CONSISTS OF STANDARD CHARACTERS WITHOUT CLAIM TO ANY PARTICULAR FONT, STYLE, SIZE, OR COLOR.
 FOR LADDERS, NAMELY, LADDERS MADE SUBSTANTIALLY OF NON-METAL COMPONENTS, EXCLUDING LADDERS SPECIFICALLY MADE FOR AND USED WITH BUNK BEDS (U.S. CLS. 2, 13, 22, 25, 32 AND 50).
 FIRST USE 5-5-2010; IN COMMERCE 5-5-2010.

4,016,814. KENO, LESLIE, NEW YORK, NY. AND KENO, LEIGH, NEW YORK, NY. SN 85-040,659. PUB. 10-26-2010, FILED 5-17-2010.

KENO BROS.

THE MARK CONSISTS OF STANDARD CHARACTERS WITHOUT CLAIM TO ANY PARTICULAR FONT, STYLE, SIZE, OR COLOR.
 NO CLAIM IS MADE TO THE EXCLUSIVE RIGHT TO USE "BROS.", APART FROM THE MARK AS SHOWN.
 FOR FURNITURE (U.S. CLS. 2, 13, 22, 25, 32 AND 50).
 FIRST USE 4-16-2010; IN COMMERCE 4-16-2010.

CLASS 20—(Continued).

4,016,825. SOUND SLEEP PRODUCTS, INC., SUMNER, WA. SN 85-043,712. PUB. 10-19-2010, FILED 5-20-2010.

ECO PAD

THE MARK CONSISTS OF STANDARD CHARACTERS WITHOUT CLAIM TO ANY PARTICULAR FONT, STYLE, SIZE, OR COLOR.
 NO CLAIM IS MADE TO THE EXCLUSIVE RIGHT TO USE "PAD", APART FROM THE MARK AS SHOWN.
 FOR MATTRESS COMPONENTS, NAMELY, INSULATOR PADS SOLD AS INTEGRAL COMPONENTS OF THE MATTRESSES (U.S. CLS. 2, 13, 22, 25, 32 AND 50).
 FIRST USE 10-22-2010; IN COMMERCE 11-1-2010.

4,016,878. SIDEPIN LIMITED, TAIPEI, TAIWAN. SN 85-058,677. PUB. 11-2-2010, FILED 6-9-2010.



NO CLAIM IS MADE TO THE EXCLUSIVE RIGHT TO USE "GARDEN", APART FROM THE MARK AS SHOWN.
 THE MARK CONSISTS OF THE WORDING "GARDEN UNITED", WITH THE WORD "GARDEN" IN LARGER FONT AND LOCATED ABOVE "UNITED", AND WITH THE "G" AND "D" HAVING MISCELLANEOUS DESIGNS COMPRISED OF CURVED LINES IN THE UPPER PORTIONS OF THE RESPECTIVE LETTERS, AND WITH AN ARC LOCATED ABOVE THE WORDING "GARDEN" AND AN ARC LOCATED BELOW THE WORDING "UNITED", AND A "LEAF" ABOVE THE WORDING "GARDEN" IN THE UPPER CENTER OF THE MARK.
 FOR BENCHES; FITTED FABRIC FURNITURE COVERS; GAZING GLOBES; PLANT STANDS (U.S. CLS. 2, 13, 22, 25, 32 AND 50).
 FIRST USE 3-16-2011; IN COMMERCE 3-16-2011.

CLASS 20—(Continued).

4,016,977. SPACESAVER CORPORATION, FORT ATKINSON, WI. SN 85-081,495. PUB. 4-26-2011, FILED 7-9-2010.

STORAGE AT WORK

THE MARK CONSISTS OF STANDARD CHARACTERS WITHOUT CLAIM TO ANY PARTICULAR FONT, STYLE, SIZE, OR COLOR.

NO CLAIM IS MADE TO THE EXCLUSIVE RIGHT TO USE "STORAGE", APART FROM THE MARK AS SHOWN. FOR SHELVING AND RACKS FOR STORAGE; FILING CABINETS; FILING AND STORAGE SHELVING; METAL STORAGE CABINETS (U.S. CLS. 2, 13, 22, 25, 32 AND 50).

FIRST USE 3-12-2011; IN COMMERCE 3-12-2011.

4,016,991. HUNTER DOUGLAS INC., UPPER SADDLE RIVER, NJ. SN 85-083,869. PUB. 11-2-2010, FILED 7-13-2010.

THE PARKWAY COLLECTION

THE MARK CONSISTS OF STANDARD CHARACTERS WITHOUT CLAIM TO ANY PARTICULAR FONT, STYLE, SIZE, OR COLOR.

NO CLAIM IS MADE TO THE EXCLUSIVE RIGHT TO USE "COLLECTION", APART FROM THE MARK AS SHOWN.

FOR INDOOR BLINDS; WINDOW SHADES (U.S. CLS. 2, 13, 22, 25, 32 AND 50).

FIRST USE 1-1-2011; IN COMMERCE 1-1-2011.

4,016,993. MYX, INC., PALM SPRINGS, CA. SN 85-084,282. PUB. 12-21-2010, FILED 7-14-2010.

TYM

THE MARK CONSISTS OF STANDARD CHARACTERS WITHOUT CLAIM TO ANY PARTICULAR FONT, STYLE, SIZE, OR COLOR.

FOR CORKBOARDS; DECORATIVE BOXES MADE OF WOOD; MAGAZINE RACKS; MAGNETIZED PHOTO FRAMES; PICTURE AND PHOTOGRAPH FRAMES; PICTURE FRAME MOLDINGS; PICTURE FRAMES; WALL FRAME FOR THE DISPLAY OF MEDIA STORAGE CONTAINERS; WALL PLAQUES MADE OF PLASTIC OR WOOD; WOOD BOXES (U.S. CLS. 2, 13, 22, 25, 32 AND 50).

FIRST USE 5-17-2010; IN COMMERCE 5-17-2010.

CLASS 20—(Continued).

4,017,086. KEL TECHNOLOGIES, KIRTLAND, OH. SN 85-114,994. PUB. 2-1-2011, FILED 8-24-2010.

Max Reflections

THE MARK CONSISTS OF STANDARD CHARACTERS WITHOUT CLAIM TO ANY PARTICULAR FONT, STYLE, SIZE, OR COLOR.

FOR WINDOW SHADES (U.S. CLS. 2, 13, 22, 25, 32 AND 50).

FIRST USE 8-24-2010; IN COMMERCE 5-19-2011.

CLASS 21—HOUSEWARES AND GLASS

4,016,349. NIGHTBIRD PRODUCTIONS, INC., WEST HOLLYWOOD, CA. SN 77-754,873. PUB. 5-4-2010, FILED 6-8-2009.

NIGHTBIRD

THE MARK CONSISTS OF STANDARD CHARACTERS WITHOUT CLAIM TO ANY PARTICULAR FONT, STYLE, SIZE, OR COLOR.

FOR BEVERAGeware (U.S. CLS. 2, 13, 23, 29, 30, 33, 40 AND 50).

FIRST USE 1-21-2011; IN COMMERCE 1-21-2011.

4,016,381. OMS INVESTMENTS, INC., LOS ANGELES, CA. SN 77-799,595. PUB. 10-27-2009, FILED 8-7-2009.

GRO-POD

THE MARK CONSISTS OF STANDARD CHARACTERS WITHOUT CLAIM TO ANY PARTICULAR FONT, STYLE, SIZE, OR COLOR.

FOR CONTAINERS FOR CULTIVATING PLANTS (U.S. CLS. 2, 13, 23, 29, 30, 33, 40 AND 50).

FIRST USE 3-0-2011; IN COMMERCE 3-0-2011.

CLASS 21—(Continued).

4,016,425. AP&G CO., INC., BROOKLYN, NY. SN 77-863,647.
PUB. 10-5-2010, FILED 11-3-2009.

BBEDS

THE MARK CONSISTS OF STANDARD CHARACTERS WITHOUT CLAIM TO ANY PARTICULAR FONT, STYLE, SIZE, OR COLOR.

FOR INSECT TRAPS, NAMELY, SUBSTRATE MOUNTING ADHESIVE LAYER FOR MONITORING THE PRESENCE OF AND TRAPPING BEDBUGS (U.S. CLS. 2, 13, 23, 29, 30, 33, 40 AND 50).

FIRST USE 5-15-2010; IN COMMERCE 5-15-2010.

4,016,436. BERRY PLASTICS CORPORATION, EVANSVILLE, IN. SN 77-871,249. PUB. 11-2-2010, FILED 11-12-2009.

ABEO

THE MARK CONSISTS OF STANDARD CHARACTERS WITHOUT CLAIM TO ANY PARTICULAR FONT, STYLE, SIZE, OR COLOR.

THE ENGLISH TRANSLATION OF "ABEO" IS "CHANGE".

FOR PLASTIC PLATES (U.S. CLS. 2, 13, 23, 29, 30, 33, 40 AND 50).

FIRST USE 4-0-2010; IN COMMERCE 4-0-2010.

4,016,478. AP&G CO., INC., BROOKLYN, NY. SN 77-889,430.
PUB. 10-5-2010, FILED 12-9-2009.

BDS

THE MARK CONSISTS OF STANDARD CHARACTERS WITHOUT CLAIM TO ANY PARTICULAR FONT, STYLE, SIZE, OR COLOR.

FOR INSECT TRAPS, NAMELY, SUBSTRATE MOUNTING ADHESIVE LAYER FOR MONITORING THE PRESENCE OF AND TRAPPING BEDBUGS (U.S. CLS. 2, 13, 23, 29, 30, 33, 40 AND 50).

FIRST USE 5-15-2010; IN COMMERCE 5-15-2010.

CLASS 21—(Continued).

4,016,484. MARVEL CHARACTERS, INC., MANHATTAN BEACH, CA. SN 77-891,601. PUB. 5-11-2010, FILED 12-11-2009.

THOR

THE MARK CONSISTS OF STANDARD CHARACTERS WITHOUT CLAIM TO ANY PARTICULAR FONT, STYLE, SIZE, OR COLOR.

OWNER OF U.S. REG. NOS. 890,918, 958,186, AND 2,933,886.

FOR BOWLS; CUPS; DISHES; DRINKING GLASSES; LUNCH BOXES; MUGS; PAPER CUPS; PAPER PLATES; TOOTHBRUSH HOLDERS (U.S. CLS. 2, 13, 23, 29, 30, 33, 40 AND 50).

FIRST USE 4-1-2011; IN COMMERCE 4-1-2011.

4,016,626. RIVE, HASTINGS, NE. SN 77-948,881. PUB. 4-19-2011, FILED 3-2-2010.

THE MARK CONSISTS OF THE STYLIZED TEXT "RIVÉ" WITH THE LETTERS "R", "I" AND "E" CAPITALIZED, AND A BROKEN "V" WITH AN EXTENDING ACCENT THAT APPEARS OVER THE "E".

THE ENGLISH TRANSLATION OF "RIVE" IN THE MARK IS "RIVER BANK".

FOR REUSABLE GLASS CONTAINERS FOR BEVERAGES FOR DOMESTIC USE (U.S. CLS. 2, 13, 23, 29, 30, 33, 40 AND 50).

FIRST USE 4-1-2010; IN COMMERCE 8-1-2010.

4,016,645. GOODMAN, MICHELE I., LITCHFIELD PARK, AZ. SN 77-958,037. PUB. 2-22-2011, FILED 3-12-2010.

BASEBOARD BUDDY

THE MARK CONSISTS OF STANDARD CHARACTERS WITHOUT CLAIM TO ANY PARTICULAR FONT, STYLE, SIZE, OR COLOR.

CLASS 21—(Continued).

NO CLAIM IS MADE TO THE EXCLUSIVE RIGHT TO USE "BASEBOARD", APART FROM THE MARK AS SHOWN.

FOR HAND-HELD BASEBOARD CLEANING IMPLEMENTS, NAMELY, A MANUALLY-OPERATED HANDLED IMPLEMENT, NAMELY, A CLEANING PAD FORMED WITH A BASEBOARD CLEANING HEAD (U.S. CLS. 2, 13, 23, 29, 30, 33, 40 AND 50).

FIRST USE 3-11-2011; IN COMMERCE 3-11-2011.

CLASS 21—(Continued).

4,016,713. ORBACH, WENDY, TORONTO, ONTARIO, CANADA. SN 78-473,970. PUB. 10-26-2010, FILED 8-26-2004.

PROTECT A PAN

4,016,682. THE EVERCARE COMPANY, ALPHARETTA, GA. SN 77-982,116. PUB. 4-20-2010, FILED 10-5-2009.

KITCHEN DÉCOR

THE MARK CONSISTS OF STANDARD CHARACTERS WITHOUT CLAIM TO ANY PARTICULAR FONT, STYLE, SIZE, OR COLOR.

NO CLAIM IS MADE TO THE EXCLUSIVE RIGHT TO USE "KITCHEN", APART FROM THE MARK AS SHOWN.

FOR GLOVES FOR HOUSEHOLD PURPOSES; RUBBER HOUSEHOLD GLOVES (U.S. CLS. 2, 13, 23, 29, 30, 33, 40 AND 50).

FIRST USE 3-0-2010; IN COMMERCE 3-0-2010.

THE MARK CONSISTS OF STANDARD CHARACTERS WITHOUT CLAIM TO ANY PARTICULAR FONT, STYLE, SIZE, OR COLOR.

NO CLAIM IS MADE TO THE EXCLUSIVE RIGHT TO USE "PAN", APART FROM THE MARK AS SHOWN.

FOR COOKWARE COVERS (U.S. CLS. 2, 13, 23, 29, 30, 33, 40 AND 50).

FIRST USE 12-31-2006; IN COMMERCE 12-31-2006.

4,016,810. PATRICK VOGEL DESIGNS, INC., SIGNAL HILL, CA. SN 85-038,881. PUB. 8-17-2010, FILED 5-14-2010.

FOREVERPOT

4,016,696. PLAYTEX PRODUCTS, LLC, SHELTON, CT. SN 77-982,197. PUB. 4-20-2010, FILED 5-9-2008.

THE MARK CONSISTS OF STANDARD CHARACTERS WITHOUT CLAIM TO ANY PARTICULAR FONT, STYLE, SIZE, OR COLOR.

FOR FLOWER POTS; PLANTERS FOR FLOWERS AND PLANTS; VASES (U.S. CLS. 2, 13, 23, 29, 30, 33, 40 AND 50).

FIRST USE 8-31-2009; IN COMMERCE 5-15-2010.



NO CLAIM IS MADE TO THE EXCLUSIVE RIGHT TO USE "TWIST 'N CLICK LEAK-PROOF SEAL", APART FROM THE MARK AS SHOWN.

FOR CHILDREN'S SPILL-PROOF DRINKING CUPS (U.S. CLS. 2, 13, 23, 29, 30, 33, 40 AND 50).

FIRST USE 10-31-2008; IN COMMERCE 10-31-2008.

4,016,811. FLOAT PRO LLC, SHOREVIEW, MN. SN 85-039,572. PUB. 10-19-2010, FILED 5-15-2010.

AARDVARK

THE MARK CONSISTS OF STANDARD CHARACTERS WITHOUT CLAIM TO ANY PARTICULAR FONT, STYLE, SIZE, OR COLOR.

FOR STRAINERS FOR HOUSEHOLD PURPOSES (U.S. CLS. 2, 13, 23, 29, 30, 33, 40 AND 50).

FIRST USE 5-21-2011; IN COMMERCE 5-21-2011.

CLASS 21—(Continued).

4,016,842. KISSMEYER, KIRSTEN, YVETTE, CAMBRIDGE, MA. SN 85-048,102. PUB. 5-17-2011, FILED 5-26-2010.

Swiftez

THE MARK CONSISTS OF STANDARD CHARACTERS WITHOUT CLAIM TO ANY PARTICULAR FONT, STYLE, SIZE, OR COLOR.

FOR COMBINATION DUSTER AND MOP (U.S. CLS. 2, 13, 23, 29, 30, 33, 40 AND 50).

FIRST USE 1-1-2011; IN COMMERCE 7-10-2011.

4,016,954. SUMMER INFANT (USA), INC., WOONSOCKET, RI. SN 85-075,338. PUB. 11-23-2010, FILED 6-30-2010.

Right Height

THE MARK CONSISTS OF STANDARD CHARACTERS WITHOUT CLAIM TO ANY PARTICULAR FONT, STYLE, SIZE, OR COLOR.

FOR BABY BATH TUB SET COMPRISING A BABY BATH TUB, RAISED BABY TUB BASE, PORTABLE BABY BATH SEAT FOR USE IN A BATH TUB, COMBINATION KNEELER AND SEAT FOR USE WHEN BATHING A BABY, AND NON-METAL STEP STOOL (U.S. CLS. 2, 13, 23, 29, 30, 33, 40 AND 50).

FIRST USE 9-0-2009; IN COMMERCE 9-0-2009.

4,017,018. HERNANDO MOSS, INC., HERNANDO, FL. SN 85-092,630. PUB. 3-15-2011, FILED 7-26-2010.

PICSANDPOSIES

THE MARK CONSISTS OF STANDARD CHARACTERS WITHOUT CLAIM TO ANY PARTICULAR FONT, STYLE, SIZE, OR COLOR.

FOR FLOWER POT INCORPORATING A PICTURE FRAME (U.S. CLS. 2, 13, 23, 29, 30, 33, 40 AND 50).

FIRST USE 3-29-2010; IN COMMERCE 5-1-2011.

CLASS 21—(Continued).

4,017,019. VIVEVITA, LLC, CHARLOTTE, NC. SN 85-092,720. PUB. 1-4-2011, FILED 7-26-2010.

Bandle

THE MARK CONSISTS OF STANDARD CHARACTERS WITHOUT CLAIM TO ANY PARTICULAR FONT, STYLE, SIZE, OR COLOR.

FOR IDENTIFICATION LABELS MADE OF STRETCHABLE BANDS OF PLASTIC, RUBBER, AND ELASTIC FOR PLACING AROUND BEVERAGE CONTAINERS FOR IDENTIFICATION PURPOSES AND FEATURING A SPACE FOR WRITING INFORMATION IN THE NATURE OF THE OWNER'S NAME, BEVERAGE CONTENT, AND DIETARY RESTRICTIONS (U.S. CLS. 2, 13, 23, 29, 30, 33, 40 AND 50).

FIRST USE 8-15-2010; IN COMMERCE 8-15-2010.

4,017,126. EVRIHOLDER PRODUCTS, LLC, ANAHEIM, CA. SN 85-133,010. PUB. 3-8-2011, FILED 9-19-2010.

PLATE-MATES

THE MARK CONSISTS OF STANDARD CHARACTERS WITHOUT CLAIM TO ANY PARTICULAR FONT, STYLE, SIZE, OR COLOR.

FOR PLASTIC PLATES (U.S. CLS. 2, 13, 23, 29, 30, 33, 40 AND 50).

FIRST USE 1-24-2011; IN COMMERCE 2-23-2011.

4,017,134. OVERDEVEST NURSERIES, L.P., BRIDGETON, NJ. SN 85-136,405. PUB. 4-5-2011, FILED 9-23-2010.

e-Pot

THE MARK CONSISTS OF STANDARD CHARACTERS WITHOUT CLAIM TO ANY PARTICULAR FONT, STYLE, SIZE, OR COLOR.

FOR FLOWER AND PLANT POTS MADE OF BIODEGRADABLE MATERIAL FOR HORTICULTURE (U.S. CLS. 2, 13, 23, 29, 30, 33, 40 AND 50).

FIRST USE 11-0-2010; IN COMMERCE 2-5-2011.

CLASS 21—(Continued).

4,017,211. ARCTIC INNOVATIONS, ANCHORAGE, AK. SN 85-178,108. PUB. 4-5-2011, FILED 11-16-2010.

CLASS 22—(Continued).

4,016,580. WM BAGCO, LLC, HOUSTON, TX. SN 77-934,101. PUB. 6-29-2010, FILED 2-11-2010.

HydroHeater

THE MARK CONSISTS OF STANDARD CHARACTERS WITHOUT CLAIM TO ANY PARTICULAR FONT, STYLE, SIZE, OR COLOR.

FOR PERSONAL FLUID HYDRATION SYSTEMS COMPRISING A FLUID RESERVOIR, A DELIVERY TUBE, A MOUTHPIECE AND A CARRYING PACK (U.S. CLS. 2, 13, 23, 29, 30, 33, 40 AND 50).

FIRST USE 1-31-2011; IN COMMERCE 1-31-2011.

TAKE IT ON

THE MARK CONSISTS OF STANDARD CHARACTERS WITHOUT CLAIM TO ANY PARTICULAR FONT, STYLE, SIZE, OR COLOR.

FOR BAGS FOR DISPOSAL OF BUILDING MATERIALS AND REFUSE (U.S. CLS. 1, 2, 7, 19, 22, 42 AND 50).

FIRST USE 6-20-2011; IN COMMERCE 6-20-2011.

4,017,264. PARIS PRESENTS INCORPORATED, GURNEE, IL. SN 85-975,464. PUB. 11-16-2010, FILED 6-21-2010.

CLASS 24—FABRICS

4,016,468. IDEA NUOVA, INC., NEW YORK, NY. SN 77-886,305. PUB. 5-4-2010, FILED 12-4-2009.

REAL TECHNIQUES

THE MARK CONSISTS OF STANDARD CHARACTERS WITHOUT CLAIM TO ANY PARTICULAR FONT, STYLE, SIZE, OR COLOR.

FOR COSMETIC BRUSHES; COSMETIC CASES SOLD FILLED WITH COSMETIC BRUSHES (U.S. CLS. 2, 13, 23, 29, 30, 33, 40 AND 50).

FIRST USE 9-30-2010; IN COMMERCE 3-31-2011.

DISTRICT 101

THE MARK CONSISTS OF STANDARD CHARACTERS WITHOUT CLAIM TO ANY PARTICULAR FONT, STYLE, SIZE, OR COLOR.

FOR BED BLANKETS; BED CANOPIES; BED COVERS; BED LINEN; BED SHEETS; BED SKIRTS; BED SPREADS; BED THROWS; BLANKET THROWS; COMFORTERS; COVERLETS; DUST RUFFLES; PILLOW CASES; PILLOW COVERS; PILLOW SHAMS; QUILTS (U.S. CLS. 42 AND 50).

FIRST USE 9-30-2010; IN COMMERCE 9-30-2010.

CLASS 22—CORDAGE AND FIBERS

4,016,288. FIBERLINKS TEXTILES INC., POINTE-CLAIRE, CANADA. SN 77-623,495. PUB. 12-7-2010, FILED 12-1-2008.

4,016,790. TIONG LIONG INDUSTRIAL CO., LTD., TAI-CHUNG HSIEN, TAIWAN. SN 85-033,494. PUB. 10-5-2010, FILED 5-7-2010.



NO CLAIM IS MADE TO THE EXCLUSIVE RIGHT TO USE "BAGS", APART FROM THE MARK AS SHOWN.

THE MARK CONSISTS OF THE WORDS "GREEN EARTH BAGS" WITH A TREE EXTENDING UPWARD FROM THE LETTER "T", THE TREE HAVING BAG-SHAPED LEAVES.

FOR MULTI-PURPOSE BAGS MADE OF CLOTH, NYLON, WOVEN POLYPROPYLENE, AND NON-WOVEN POLYPROPYLENE; CLOTH BAGS FOR STORAGE OF HOUSEHOLD ITEMS AND CLOTHING AND NOT IN THE NATURE OF LUGGAGE FOR TRAVEL (U.S. CLS. 1, 2, 7, 19, 22, 42 AND 50).

FIRST USE 6-1-2008; IN COMMERCE 6-1-2008.

ARIAPRENE

THE MARK CONSISTS OF STANDARD CHARACTERS WITHOUT CLAIM TO ANY PARTICULAR FONT, STYLE, SIZE, OR COLOR.

FOR FABRICS FOR TEXTILE USE (U.S. CLS. 42 AND 50).

FIRST USE 4-0-2010; IN COMMERCE 4-0-2010.

CLASS 24—(Continued).

4,016,812. FENTEM, LAURA J., DBA NEIGHBORHOOD HEALTH AND FITNESS "2" GO, CHANTILLY, VA. SN 85-039,715. PUB. 11-9-2010, FILED 5-16-2010.

cool cuddlers

FOR FABRICS FOR THE MANUFACTURE OF CART HANDLE COVERS (U.S. CLS. 42 AND 50).
FIRST USE 6-1-2010; IN COMMERCE 6-12-2011.

4,017,058. ALOK INTERNATIONAL INC., DALLAS, TX. SN 85-106,417. PUB. 11-23-2010, FILED 8-12-2010.

OPTI-FIT

THE MARK CONSISTS OF STANDARD CHARACTERS WITHOUT CLAIM TO ANY PARTICULAR FONT, STYLE, SIZE, OR COLOR.

FOR BEDSHEETS (U.S. CLS. 42 AND 50).
FIRST USE 4-0-2011; IN COMMERCE 4-0-2011.

CLASS 25—CLOTHING

4,016,146. ISACO INTERNATIONAL CORPORATION, MIAMI LAKES, FL. SN 76-364,262. PUB. 3-25-2008, FILED 1-29-2002.

PAPITO

OWNER OF U.S. REG. NO. 2,161,178.
THE ENGLISH TRANSLATION OF THE MARK IS "LITTLE FATHER".

FOR WEARING APPAREL FOR MEN AND CHILDREN, NAMELY, T-SHIRTS, HATS, UNDERGARMENTS, WARM UP PANTS, SWEAT SHIRTS, SWEAT SHORTS, SWIMWEAR, BATHING SUITS, BEACH AND BATHING COVERUPS, TOPS, JACKETS, COATS, KNIT SHIRTS, POLO SHIRTS, PULLOVERS, VESTS, TANK TOPS, WIND RESISTANT JACKETS (U.S. CLS. 22 AND 39).

FIRST USE 6-8-2011; IN COMMERCE 6-8-2011.

CLASS 25—(Continued).

4,016,169. THOMAS C. FORD, AUSTIN, TX. SN 77-073,498. PUB. 8-28-2007, FILED 12-29-2006.

TF

THE MARK CONSISTS OF THE INITIALS "TF".
FOR CLOTHING, NAMELY, BELTS, JACKETS, MEN'S SHOES AND BOOTS (U.S. CLS. 22 AND 39).
FIRST USE 9-1-2009; IN COMMERCE 9-1-2009.

4,016,190. AULBACH LIZENZ AG, CHUR, SWITZERLAND. SN 77-204,152. PUB. 4-8-2008, FILED 6-12-2007.

COUTURE
DANIEL HECHTER

OWNER OF U.S. REG. NOS. 2,796,768, 2,879,137, AND OTHERS.

NO CLAIM IS MADE TO THE EXCLUSIVE RIGHT TO USE "COUTURE", APART FROM THE MARK AS SHOWN.

THE NAME(S), PORTRAIT(S), AND/OR SIGNATURE(S) SHOWN IN THE MARK IDENTIFIES "DANIEL HECHTER", WHOSE CONSENT(S) TO REGISTER IS SUBMITTED.

FOR CLOTHING, NAMELY, TROUSERS, SUITS, JACKETS, COATS, PANTS; CLOTHING OF LEATHER, NAMELY, JACKETS (U.S. CLS. 22 AND 39).

FIRST USE 9-0-2009; IN COMMERCE 1-0-2011.

CLASS 25—(Continued).

4,016,192. FALLICK, MARCELO ANDRES, HOUSTON, TX. SN 77-218,428. PUB. 12-4-2007, FILED 6-28-2007.

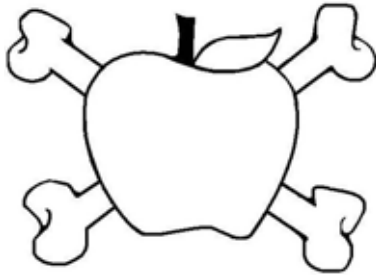

THE MARK CONSISTS OF AN APPLE IN FRONT OF CROSSBONES.
FOR SHIRTS; SWIMSUITS; HATS; SHOES; SHORTS (U.S. CLS. 22 AND 39).
FIRST USE 5-1-2010; IN COMMERCE 10-1-2010.

4,016,200. Y.E., LLC, GREENVILLE, KY. SN 77-282,044. PUB. 3-2-2010, FILED 9-18-2007.



THE STIPPLING IS FOR SHADING PURPOSES ONLY.
THE MARK CONSISTS OF "YE" HAVING THE CAPITAL LETTER "Y" IN A CROSS-TYPE FORM AND THE SMALLER CAPITAL LETTER "E" CONNECTING TO THE CROSS BY THE MIDDLE LATERAL LINE; THE MARK IS ON A DARK BACKGROUND.
FOR PANTS; SHIRTS (U.S. CLS. 22 AND 39).
FIRST USE 6-27-2007; IN COMMERCE 6-27-2007.

4,016,203. EDDY, MICHAEL, ORMOND BEACH, FL. SN 77-296,091. PUB. 3-11-2008, FILED 10-4-2007.

RABID DEER

THE MARK CONSISTS OF STANDARD CHARACTERS WITHOUT CLAIM TO ANY PARTICULAR FONT, STYLE, SIZE, OR COLOR.
FOR HATS, T-SHIRTS, JACKETS, SWEATSHIRTS, TANK TOPS (U.S. CLS. 22 AND 39).
FIRST USE 7-1-2008; IN COMMERCE 5-15-2011.

CLASS 25—(Continued).

4,016,205. PARABELLUM COLLECTION INC., LOS ANGELES, CA. SN 77-307,931. PUB. 4-1-2008, FILED 10-18-2007.

PARABELLUM

THE MARK CONSISTS OF STANDARD CHARACTERS WITHOUT CLAIM TO ANY PARTICULAR FONT, STYLE, SIZE, OR COLOR.
FOR TOPS; JACKETS; FOOTWEAR (U.S. CLS. 22 AND 39).
FIRST USE 6-20-2011; IN COMMERCE 6-20-2011.

4,016,208. FGD, INC., BEVERLY HILLS, CA. SN 77-315,895. PUB. 4-15-2008, FILED 10-29-2007.



THE MARK CONSISTS OF TWO FACING LETTER "F"'S IN A HEART, WITH THE TERM "FRANNE" OUTSIDE THE HEART.
FOR CLOTHING, NAMELY, DRESSES, PANTS, SHORTS, SKIRTS, BLOUSES, KNIT AND WOVEN TOPS, SWEATERS, T-SHIRTS, SWEATPANTS, SWEATSHIRTS, SWEATSUITS; OUTERWEAR, NAMELY, JACKETS, VESTS, COATS, SHELLS; AND HEADGEAR, NAMELY, HATS, CAPS, HEADBANDS, VISORS, AND BELTS (U.S. CLS. 22 AND 39).
FIRST USE 9-1-2007; IN COMMERCE 7-1-2009.

4,016,218. B(R)AND MATTER, LLC, NEW YORK, NY. SN 77-331,268. PUB. 4-22-2008, FILED 11-16-2007.

**CARIBBEAN JOE ISLAND
SUPPLY CO.**

THE MARK CONSISTS OF STANDARD CHARACTERS WITHOUT CLAIM TO ANY PARTICULAR FONT, STYLE, SIZE, OR COLOR.

CLASS 25—(Continued).

OWNER OF U.S. REG. NO. 2,845,458.

NO CLAIM IS MADE TO THE EXCLUSIVE RIGHT TO USE "ISLAND SUPPLY CO.", APART FROM THE MARK AS SHOWN.

THE NAME "CARIBBEAN JOE" DOES NOT IDENTIFY A LIVING INDIVIDUAL.

FOR MEN'S AND WOMEN'S APPAREL, NAMELY, WOVEN TOPS, KNIT TOPS, POLO SHIRTS, TEE SHIRTS, SWEATERS, PANTS, SHORTS, CAPRIS, WOVEN BOTTOMS, SWIMWEAR; FOOTWEAR, NAMELY, SANDALS AND FLIP FLOPS (U.S. CLS. 22 AND 39).

FIRST USE 10-30-2008; IN COMMERCE 10-30-2008.

CLASS 25—(Continued).

4,016,244. SMAC, INC., CITY OF INDUSTRY, CA. SN 77-382,630. PUB. 6-10-2008, FILED 1-28-2008.

C LABEL

4,016,220. CONSOLIDATED SHOE COMPANY, INC., LYNCHBURG, VA. SN 77-335,271. PUB. 4-15-2008, FILED 11-21-2007.

DIMMI

THE MARK CONSISTS OF STANDARD CHARACTERS WITHOUT CLAIM TO ANY PARTICULAR FONT, STYLE, SIZE, OR COLOR.

NO CLAIM IS MADE TO THE EXCLUSIVE RIGHT TO USE "LABEL", APART FROM THE MARK AS SHOWN.

FOR SHOES (U.S. CLS. 22 AND 39).

FIRST USE 5-15-2011; IN COMMERCE 5-25-2011.

THE MARK CONSISTS OF STANDARD CHARACTERS WITHOUT CLAIM TO ANY PARTICULAR FONT, STYLE, SIZE, OR COLOR.

THE FOREIGN WORDING IN THE MARK TRANSLATES INTO ENGLISH AS TELL ME.

FOR CLOTHING, NAMELY, TOPS, SHIRTS, T-SHIRTS (U.S. CLS. 22 AND 39).

FIRST USE 6-28-2011; IN COMMERCE 6-28-2011.

4,016,266. FRASER, STANFORD L, CHARLOTTE, NC. SN 77-481,043. PUB. 3-9-2010, FILED 5-22-2008.

4,016,222. NOR-CAL BEVERAGE CO., INC., WEST SACRAMENTO, CA. SN 77-337,151. PUB. 6-1-2010, FILED 11-26-2007.

ANARKE JEANS**GO GIRL SUGAR FREE ENERGY
DRINK**

THE MARK CONSISTS OF STANDARD CHARACTERS WITHOUT CLAIM TO ANY PARTICULAR FONT, STYLE, SIZE, OR COLOR.

OWNER OF U.S. REG. NOS. 3,235,947, 3,719,981, AND OTHERS.

NO CLAIM IS MADE TO THE EXCLUSIVE RIGHT TO USE "SUGAR FREE ENERGY DRINK", APART FROM THE MARK AS SHOWN.

FOR CLOTHING, NAMELY, HATS, SWEAT SHIRTS, T-SHIRTS, SHIRTS, AND TANK TOPS USED FOR THE PROMOTION OF ENERGY DRINKS (U.S. CLS. 22 AND 39).

FIRST USE 6-24-2006; IN COMMERCE 11-27-2006.

THE MARK CONSISTS OF STANDARD CHARACTERS WITHOUT CLAIM TO ANY PARTICULAR FONT, STYLE, SIZE, OR COLOR.

NO CLAIM IS MADE TO THE EXCLUSIVE RIGHT TO USE "JEANS", APART FROM THE MARK AS SHOWN.

FOR COATS; COATS FOR MEN AND WOMEN; COATS MADE OF COTTON; COATS OF DENIM; DRESS SHIRTS; GOLF SHIRTS; HEAVY COATS; HOODED SWEAT SHIRTS; JEANS; KNIT SHIRTS; LEATHER COATS; LONG-SLEEVED SHIRTS; OPEN-NECKED SHIRTS; POLO SHIRTS; RUGBY SHIRTS; SHIRTS; SHORT-SLEEVED OR LONG-SLEEVED T-SHIRTS; SHORT-SLEEVED SHIRTS; SPORT COATS; SWEAT SHIRTS; T-SHIRTS (U.S. CLS. 22 AND 39).

FIRST USE 1-1-2008; IN COMMERCE 5-1-2008.

CLASS 25—(Continued).

4,016,272. THE AUGUSTANA COLLEGE ASSOCIATION, SIOUX FALLS, SD. SN 77-525,025. PUB. 7-14-2009, FILED 7-17-2008.



THE MARK CONSISTS OF THE WORDING "AUGUSTANA VIKINGS", STYLIZED, COMBINED WITH A DESIGN CONSISTING OF THE HEAD OF A VIKING AND A SWORD.

FOR CLOTHING, NAMELY, SHIRTS AND SWEATSHIRTS (U.S. CLS. 22 AND 39).

FIRST USE 0-0-2008; IN COMMERCE 0-0-2008.

4,016,318. DENIM PROJECT LLC, NEW YORK, NY. SN 77-703,646. PUB. 10-20-2009, FILED 3-31-2009.

TEN25

THE MARK CONSISTS OF STANDARD CHARACTERS WITHOUT CLAIM TO ANY PARTICULAR FONT, STYLE, SIZE, OR COLOR.

FOR CLOTHING, NAMELY, SHIRTS, T-SHIRTS, LONG-SLEEVED SHIRTS, UNDERSHIRTS, POLO SHIRTS, NIGHT SHIRTS, TOPS AND BOTTOMS RESEMBLING SCRUB SUITS, NOT INTENDED TO BE WORN IN MEDICAL SETTINGS, SMOCKS, STRETCH PANTS, OVERALLS, COVERALLS, DENIM JEANS, JUMPERS, JUMPSUITS, STRETCH TOPS, TUBE TOPS, CROP TOPS, HALTER TOPS, HOODED SWEAT SHIRTS, WRAPS, WARM UP SUITS, JOGGING SUITS, TRACK SUITS, SHAWLS, CARDIGANS, PANTS, JEAN JACKETS, CARGO PANTS, SHORTS, BOXER SHORTS, TOPS, TANK TOPS, SWEAT SHIRTS, SWEAT JACKETS, SWEAT SHORTS, SWEAT PANTS, BLOUSES, DRESSES, SWEATERS, VESTS, FLEECE VESTS, PULLOVERS, JACKETS, COATS, BLAZERS, GOLF AND SKI JACKETS, HEAVY COATS, OVER COATS (U.S. CLS. 22 AND 39).

FIRST USE 1-0-2009; IN COMMERCE 1-0-2009.

CLASS 25—(Continued).

4,016,325. MICHAEL NITTEL, DBA DEALERS INC., UPLAND, CA. SN 77-725,096. PUB. 9-29-2009, FILED 4-29-2009.

DEALERS INC.

THE MARK CONSISTS OF STANDARD CHARACTERS WITHOUT CLAIM TO ANY PARTICULAR FONT, STYLE, SIZE, OR COLOR.

NO CLAIM IS MADE TO THE EXCLUSIVE RIGHT TO USE "INC.", APART FROM THE MARK AS SHOWN. FOR CLOTHING, NAMELY, SHIRTS, SWEATSHIRTS, PANTS, SOCKS, BOARD SHORTS, AND HOODED SWEATSHIRTS (U.S. CLS. 22 AND 39).

FIRST USE 6-1-2010; IN COMMERCE 6-1-2010.

4,016,339. TAILGATE CLOTHING CO., ANKENY, IA. SN 77-747,471. PUB. 4-13-2010, FILED 5-29-2009.



THE MARK CONSISTS OF A STYLIZED LETTER "T" THAT CONTAINS THE WORD "UNIVERSITY".

FOR CLOTHING, NAMELY, T-SHIRTS, SWEATSHIRTS, THERMALS, RAGLANS, SWEATPANTS, AND TRACK JACKETS FOR MEN, WOMEN, BOYS, GIRLS, AND TODDLERS (U.S. CLS. 22 AND 39).

FIRST USE 7-31-2009; IN COMMERCE 7-31-2009.

4,016,377. NORTH BAY APPAREL, LLC, NEW YORK, NY. SN 77-793,125. PUB. 3-29-2011, FILED 7-30-2009.

Trilogy Sportswear

THE MARK CONSISTS OF STANDARD CHARACTERS WITHOUT CLAIM TO ANY PARTICULAR FONT, STYLE, SIZE, OR COLOR.

OWNER OF U.S. REG. NO. 2,726,861.

CLASS 25—(Continued).

NO CLAIM IS MADE TO THE EXCLUSIVE RIGHT TO USE "SPORTSWEAR", APART FROM THE MARK AS SHOWN.
 FOR MEN'S AND BOYS PANTS, SHORTS, JEANS, JACKETS, VESTS AND ACTIVE WEAR, NAMELY, TEE-SHIRTS, FLEECE SHIRTS (U.S. CLS. 22 AND 39).
 FIRST USE 10-0-1986; IN COMMERCE 10-0-1986.

CLASS 25—(Continued).

4,016,394. RHITA PEREZ, BEVERLY HILLS, CA. SN 77-818,932. PUB. 6-1-2010, FILED 9-2-2009.

AYO

4,016,388. LUSHINGTON GARRELL, LOS ANGELES, CA. SN 77-811,772. PUB. 12-22-2009, FILED 8-25-2009.



THE MARK CONSISTS OF STANDARD CHARACTERS WITHOUT CLAIM TO ANY PARTICULAR FONT, STYLE, SIZE, OR COLOR.

FOR CLOTHING, NAMELY, PANTS, SHORTS, SWEATPANTS, OVERALLS, SHIRTS, TEE-SHIRTS, SWEATSHIRTS, BLOUSES, SKIRTS, DRESSES, JACKETS, VESTS, COATS, RAINWEAR, SHOES, LINGERIE, SLEEPWEAR, LOUNGEWEAR, SWIMWEAR, GLOVES, SOCKS, HOSIERY, BELTS, SCARVES, HATS, TIES, AND SLIPPERS (U.S. CLS. 22 AND 39).

FIRST USE 9-2-2009; IN COMMERCE 9-2-2009.

4,016,396. PACIFIC COAST FITNESS LLC, DBA GRATITUDE ORGANICS, LOS ANGELES, CA. SN 77-819,673. PUB. 3-23-2010, FILED 9-3-2009.



THE MARK CONSISTS OF THE WORDING "SAFE SEX" APPEARING VERTICALLY, IN ALL CAPITAL LETTERS, AND IN STYLIZED FONT, TO THE RIGHT OF THE "SAFE SEX" WORDING APPEARS A CARTOON FIGURE OF A WOMAN WITH LONG HAIR AND WEARING A SHIRT, PANTS, AND SHOES, TO THE RIGHT OF THE WOMAN APPEARS A CARTOON FIGURE OF A MAN WITH SHORT HAIR AND WEARING A SHIRT, PANTS, AND SHOES, THE ARMS OF THE MAN AND THE WOMAN APPEAR CONNECTED IN THE SHAPE OF A SIDEWAYS HEART, AN IMAGE A SCREW APPEARS ACROSS THE FIGURE OF THE MAN AND THE WOMAN AT THE POINT WHERE THEIR ARMS ARE CONNECTED, BELOW THE IMAGE OF THE SCREW APPEARS THE WORDING "DON'T SCREW TOGETHER SAFE SEX", THE "DON'T SCREW TOGETHER" WORDING APPEARS SO THAT THE FIRST LETTER IN EACH WORD IS A CAPITAL LETTER AND THE REMAINING LETTERS APPEAR IN LOWER CASE, THE "DON'T SCREW TOGETHER" WORDING ALSO APPEARS IN STYLIZED FONT, THE "SAFE SEX" WORDING APPEARS IN CALL CAPITAL LETTERS AND IN STYLIZED FONT, THE ARRANGEMENT OF THE "DON'T SCREW TOGETHER SAFE SEX" WORDING APPEARS SO THAT EACH WORD IS STACKED ON TOP OF ONE ANOTHER.

FOR HOODED SWEAT SHIRTS; JACKETS; JEANS; LONG-SLEEVED SHIRTS; MEN'S UNDERWEAR; SHIRTS; SPORTS SHIRTS; SWEAT SHIRTS; T-SHIRTS; TEE SHIRTS; UNDERWEAR (U.S. CLS. 22 AND 39).
 FIRST USE 4-10-2011; IN COMMERCE 4-14-2011.

NO CLAIM IS MADE TO THE EXCLUSIVE RIGHT TO USE "ORGANICS", APART FROM THE MARK AS SHOWN. THE MARK CONSISTS OF THE LOGO IS A HAND DRAWN FONT WITHOUT ANY KNOWN REFERENCE OR USE OF EXISTING FONTS.

FOR CHILDREN'S AND INFANT'S APPAREL, NAMELY, JUMPERS, OVERALL SLEEPWEAR, PAJAMAS, ROMPERS AND ONE-PIECE GARMENTS; SHIRTS FOR INFANTS, BABIES, TODDLERS AND CHILDREN; T-SHIRTS; ALL OF THE FOREGOING GOODS ARE MADE FROM 100% ORGANIC MATERIALS (U.S. CLS. 22 AND 39).
 FIRST USE 11-18-2009; IN COMMERCE 12-18-2009.

CLASS 25—(Continued).

4,016,472. FLUENT, JEFFERY, MODESTO, CA. SN 77-887,784. PUB. 5-11-2010, FILED 12-7-2009.

I JUST WANT TO GET IT WET

THE MARK CONSISTS OF STANDARD CHARACTERS WITHOUT CLAIM TO ANY PARTICULAR FONT, STYLE, SIZE, OR COLOR.

FOR HATS; JACKETS; SHIRTS; SWEAT SHIRTS (U.S. CLS. 22 AND 39).

FIRST USE 11-24-2010; IN COMMERCE 11-24-2010.

4,016,481. FEAR NO FASHION, INC. LOS ANGELES, CA. SN 77-890,020. PUB. 5-4-2010, FILED 12-9-2009.

Hollywood Slim

THE MARK CONSISTS OF STANDARD CHARACTERS WITHOUT CLAIM TO ANY PARTICULAR FONT, STYLE, SIZE, OR COLOR.

NO CLAIM IS MADE TO THE EXCLUSIVE RIGHT TO USE "HOLLYWOOD", APART FROM THE MARK AS SHOWN.

FOR BODY SHIRTS; MUSCLE TOPS; SHAPEWEAR, NAMELY, COMPRESSION UNDERGARMENTS, COMPRESSION TOPS, COMPRESSION SHORTS; SHORT-SLEEVED OR LONG-SLEEVED T-SHIRTS; T-SHIRTS; TANK TOPS; UNDERGARMENTS; YOGA PANTS; YOGA SHIRTS (U.S. CLS. 22 AND 39).

FIRST USE 5-0-2010; IN COMMERCE 5-0-2010.

4,016,504. GOLDEN TOUCH IMPORTS, INC., NEW YORK, NY. SN 77-895,452. PUB. 11-23-2010, FILED 12-17-2009.

101 OCEAN PARKWAY

THE MARK CONSISTS OF STANDARD CHARACTERS WITHOUT CLAIM TO ANY PARTICULAR FONT, STYLE, SIZE, OR COLOR.

FOR WOMEN'S AND JUNIOR WOMEN'S CLOTHING AND APPAREL, NAMELY, DRESSES, PANTS, SKIRTS, TOPS, SHIRTS, BLOUSES, SWEATERS, ROMPERS, T-SHIRTS, SWEATSHIRTS, SWEAT PANTS, SHORTS, JACKETS, COATS, BLAZERS AND HEADWEAR (U.S. CLS. 22 AND 39).

FIRST USE 11-0-2009; IN COMMERCE 1-0-2010.

CLASS 25—(Continued).

4,016,527. ROBINSON, TRAVIS, DBA CASH ROBINSON CLOTHING CO., LOVELAND, OH. SN 77-904,916. PUB. 11-9-2010, FILED 1-5-2010.

Cash Robinson

THE MARK CONSISTS OF STANDARD CHARACTERS WITHOUT CLAIM TO ANY PARTICULAR FONT, STYLE, SIZE, OR COLOR.

THE NAME(S), PORTRAIT(S), AND/OR SIGNATURE(S) SHOWN IN THE MARK DOES NOT IDENTIFY A PARTICULAR LIVING INDIVIDUAL.

FOR WEARABLE GARMENTS AND CLOTHING, NAMELY, SHIRTS (U.S. CLS. 22 AND 39).

FIRST USE 2-25-2011; IN COMMERCE 2-25-2011.

4,016,529. COOKE VENTURES, LLC, DBA VINTAGE SWEATERS, STATEN ISLAND, NY. SN 77-906,338. PUB. 11-30-2010, FILED 1-6-2010.

GAMEDAY sweater

THE MARK CONSISTS OF STANDARD CHARACTERS WITHOUT CLAIM TO ANY PARTICULAR FONT, STYLE, SIZE, OR COLOR.

NO CLAIM IS MADE TO THE EXCLUSIVE RIGHT TO USE "SWEATER", APART FROM THE MARK AS SHOWN.

FOR SWEATERS (U.S. CLS. 22 AND 39).

FIRST USE 9-10-2010; IN COMMERCE 9-10-2010.

4,016,535. MALIBU KIDZ, LLC, SUNNYVALE, CA. SN 77-908,455. PUB. 12-21-2010, FILED 1-9-2010.



NO CLAIM IS MADE TO THE EXCLUSIVE RIGHT TO USE "KIDS", APART FROM THE MARK AS SHOWN.

CLASS 25—(Continued).

THE MARK CONSISTS OF THE TEXT "MALIBU KIDZ" IN TWO (2) FONT STYLES. THE PORTION "MALIBU KID" IS RAGE ITALIC FONT, THE "Z" PORTION OF THE MARK IS AGENCY FB FONT.

FOR ATHLETIC APPAREL, NAMELY, SHIRTS, PANTS, JACKETS, FOOTWEAR, HATS AND CAPS, ATHLETIC UNIFORMS; CHILDREN'S AND INFANT'S APPAREL, NAMELY, JUMPERS, OVERALL SLEEPWEAR, PAJAMAS, ROMPERS AND ONE-PIECE GARMENTS (U.S. CLS. 22 AND 39).

FIRST USE 7-2-2010; IN COMMERCE 9-6-2010.

4,016,559. SINDACO, ALFRED RONALD, DBA JUST BEND, MALVERN, PA. AND SINDACO, MARGARET M, DBA JUST BEND, MALVERN, PA. SN 77-921,865. PUB. 6-15-2010, FILED 1-27-2010.

Just Bend.

THE MARK CONSISTS OF STANDARD CHARACTERS WITHOUT CLAIM TO ANY PARTICULAR FONT, STYLE, SIZE, OR COLOR.

FOR ADULT NOVELTY GAG CLOTHING ITEM, NAMELY, SOCKS; BELTS; BELTS FOR CLOTHING; BELTS MADE OUT OF CLOTH; BOTTOMS; CHILDREN'S AND INFANTS' CLOTH BIBS; CHILDREN'S CLOTH EATING BIBS; CLOTH BIBS; EYESHADES; JACKETS; JERSEYS; LEATHER BELTS; TOPS; WEARABLE GARMENTS AND CLOTHING, NAMELY, SHIRTS (U.S. CLS. 22 AND 39).

FIRST USE 4-1-2010; IN COMMERCE 4-1-2010.

4,016,563. MARLON BLAIR, DBA GO HARD CLOTHING A DESIGN BY MARLON BLAIR, ELK GROVE, CA. SN 77-924,338. PUB. 7-20-2010, FILED 1-30-2010.



a design by Marlon Blair

NO CLAIM IS MADE TO THE EXCLUSIVE RIGHT TO USE "CLOTHING" AND "DESIGN", APART FROM THE MARK AS SHOWN.

THE NAME "MARLON BLAIR" IDENTIFIES A LIVING INDIVIDUAL WHOSE CONSENT IS OF RECORD.

THE MARK CONSISTS OF A DESIGN OF THE "G" WHICH SWISHES TO INTERSECT WITH THE "H", THEN FOLLOWED BY THE "O" AND "ARD" AND CREATES THE WORD "GO HARD". "CLOTHING A DESIGN BY MARLON BLAIR" IS FOLLOWED WITH CUSTOMIZED FONT.

FOR ATHLETIC APPAREL, NAMELY, SHIRTS, PANTS, JACKETS, FOOTWEAR, HATS AND CAPS, ATHLETIC UNIFORMS; SHORT-SLEEVED OR LONG-SLEEVED T-SHIRTS; T-SHIRTS (U.S. CLS. 22 AND 39).

FIRST USE 12-15-2009; IN COMMERCE 1-15-2010.

CLASS 25—(Continued).

4,016,565. JOHNSON, MONA, SALISBURY, MA. AND JOHNSON, TIMOTHY, SALISBURY, MA. SN 77-925,497. PUB. 6-15-2010, FILED 2-2-2010.

METAMORPHIC WEAR

THE MARK CONSISTS OF STANDARD CHARACTERS WITHOUT CLAIM TO ANY PARTICULAR FONT, STYLE, SIZE, OR COLOR.

NO CLAIM IS MADE TO THE EXCLUSIVE RIGHT TO USE "WEAR", APART FROM THE MARK AS SHOWN.

FOR CLOTHING PRODUCTS, NAMELY, TOPS, PANTS, SHIRTS, JACKETS, JERSEYS, HATS, CAPS, FOOTWEAR, TRACK SUITS, YOGA PANTS, SPORTS JERSEYS AND CHEERLEADING WARM-UP SUITS FOR CONSUMERS, ATHLETES, CHILDREN, COACHES AND SPORTS TEAMS (U.S. CLS. 22 AND 39).

FIRST USE 12-17-2009; IN COMMERCE 12-17-2009.

4,016,568. SAITEX INTERNATIONAL INC., NEW YORK, NY. SN 77-926,587. PUB. 6-22-2010, FILED 2-3-2010.

D9

THE MARK CONSISTS OF STANDARD CHARACTERS WITHOUT CLAIM TO ANY PARTICULAR FONT, STYLE, SIZE, OR COLOR.

FOR CAPS; FOOTWEAR; HATS; JACKETS; JEANS; JOGGING SUITS; PANTS; SHIRTS; T-SHIRTS; TOPS; TROUSERS; UNDERWEAR (U.S. CLS. 22 AND 39).

FIRST USE 6-30-2010; IN COMMERCE 6-30-2010.

4,016,572. VADAKAN-MYUNG, LOS ANGELES, CA. SN 77-930,053. PUB. 1-25-2011, FILED 2-8-2010.

ART FOR YOUR EVERYDAY

THE MARK CONSISTS OF STANDARD CHARACTERS WITHOUT CLAIM TO ANY PARTICULAR FONT, STYLE, SIZE, OR COLOR.

FOR CLOTHING, NAMELY, T-SHIRTS, SWEATSHIRTS, JACKETS (U.S. CLS. 22 AND 39).

FIRST USE 1-31-2004; IN COMMERCE 1-31-2004.

CLASS 25—(Continued).

4,016,584. MENDEZ OLIVETO, EVELYN, SHERMAN OAKS, CA. AND OLIVETO, LEONARDO A., SHERMAN OAKS, CA. SN 77-935,123. PUB. 7-6-2010, FILED 2-12-2010.

BEWARE OF SHADOWS

THE MARK CONSISTS OF STANDARD CHARACTERS WITHOUT CLAIM TO ANY PARTICULAR FONT, STYLE, SIZE, OR COLOR.
FOR TEE SHIRTS; SHIRTS; SHIRTS AND SHORT-SLEEVED SHIRTS (U.S. CLS. 22 AND 39).
FIRST USE 5-1-2010; IN COMMERCE 7-1-2010.

4,016,592. DOE GEAR, LLC, CLINTON TOWNSHIP, MI. SN 77-937,798. PUB. 9-21-2010, FILED 2-17-2010.

DOE GEAR

THE MARK CONSISTS OF STANDARD CHARACTERS WITHOUT CLAIM TO ANY PARTICULAR FONT, STYLE, SIZE, OR COLOR.
NO CLAIM IS MADE TO THE EXCLUSIVE RIGHT TO USE "GEAR", APART FROM THE MARK AS SHOWN.
FOR SPORTING APPAREL, STREET APPAREL AND LAW ENFORCEMENT APPAREL, NAMELY, JACKETS, COATS, HATS, CAPS, SHIRTS (U.S. CLS. 22 AND 39).
FIRST USE 4-28-2011; IN COMMERCE 5-3-2011.

4,016,621. DIERDRE WALLACE, DBA DEEFIND, SAN FRANCISCO, CA. SN 77-947,899. PUB. 7-27-2010, FILED 3-2-2010.

deeFind

THE MARK CONSISTS OF STANDARD CHARACTERS WITHOUT CLAIM TO ANY PARTICULAR FONT, STYLE, SIZE, OR COLOR.
FOR WOMEN'S SHOES (U.S. CLS. 22 AND 39).
FIRST USE 11-1-2010; IN COMMERCE 11-1-2010.

CLASS 25—(Continued).

4,016,660. AUGÉ, INC., NORTH PORT, FL. SN 77-966,929. PUB. 8-10-2010, FILED 3-24-2010.

AUGE

THE MARK CONSISTS OF STANDARD CHARACTERS WITHOUT CLAIM TO ANY PARTICULAR FONT, STYLE, SIZE, OR COLOR.
FOR ATHLETIC CLOTHING, NAMELY, SHIRTS, HATS, SOCKS AND SHOES (U.S. CLS. 22 AND 39).
FIRST USE 1-9-2009; IN COMMERCE 1-9-2009.

4,016,661. AUGÉ, INC., NORTH PORT, FL. SN 77-966,935. PUB. 8-10-2010, FILED 3-24-2010.

ALL U GOT EVERYDAY

THE MARK CONSISTS OF STANDARD CHARACTERS WITHOUT CLAIM TO ANY PARTICULAR FONT, STYLE, SIZE, OR COLOR.
FOR ATHLETIC CLOTHING, NAMELY, SHIRTS, HATS, SOCKS AND SHOES (U.S. CLS. 22 AND 39).
FIRST USE 1-9-2009; IN COMMERCE 1-9-2009.

4,016,675. INTERNATIONAL FASHIONS, LTD., VANCOUVER, CANADA. SN 77-982,073. PUB. 7-28-2009, FILED 6-26-2007.

PRESS

THE MARK CONSISTS OF STANDARD CHARACTERS WITHOUT CLAIM TO ANY PARTICULAR FONT, STYLE, SIZE, OR COLOR.
FOR WOMEN'S CLOTHING AND ACCESSORIES, NAMELY, JEANS, SHIRTS, T-SHIRTS, SHORTS, PANTS, SKIRTS, JUMPERS, SWEATERS, JACKETS, COATS, DRESSES, SUITS, VESTS, SLEEPWEAR, LOUNGEWEAR, LINGERIE, ROBES, PAJAMAS, UNDERWEAR, BATHING SUITS, HOSIERY, TIGHTS, LEGGINGS, OVERALLS, BELTS, CAPS, HATS, GLOVES, MITTENS, SLIPPERS, SCARVES AND SHOES (U.S. CLS. 22 AND 39).
FIRST USE 3-27-2008; IN COMMERCE 3-27-2008.

CLASS 25—(Continued).

4,016,679. GABRIELLE STUDIO, INC., NEW YORK, NY. SN 77-982,104. PUB. 1-4-2011, FILED 8-5-2009.

FOR A WOMAN BY A WOMAN

THE MARK CONSISTS OF STANDARD CHARACTERS WITHOUT CLAIM TO ANY PARTICULAR FONT, STYLE, SIZE, OR COLOR.

FOR COATS, BLAZERS, JACKETS, CARDIGANS, TOPS, KNIT TOPS, SUITS, DRESSES, EVENING GOWNS, SKIRTS, PANTS, JEANS, SWEATERS, SHIRTS, BLOUSES, T-SHIRTS, TANK TOPS, BODYSUITS, CAMI-SOLES, CHEMISES, LEGGINGS, SCARVES, SHAWLS, GLOVES, BELTS, HATS (U.S. CLS. 22 AND 39).

FIRST USE 8-14-2009; IN COMMERCE 8-14-2009.

4,016,692. RETAIL ROYALTY COMPANY, LAS VEGAS, NV. SN 77-982,168. PUB. 5-18-2010, FILED 12-2-2009.

LITTLE77

THE MARK CONSISTS OF STANDARD CHARACTERS WITHOUT CLAIM TO ANY PARTICULAR FONT, STYLE, SIZE, OR COLOR.

OWNER OF U.S. REG. NOS. 2,601,845, 3,738,176, AND OTHERS.

FOR CLOTHING, NAMELY, JEANS, SHORTALLS, AND COATS (U.S. CLS. 22 AND 39).

FIRST USE 7-0-2010; IN COMMERCE 7-0-2010.

4,016,695. SKIDDERS FOOTWEAR INC., NEW YORK, NY. SN 77-982,184. PUB. 10-26-2010, FILED 9-25-2009.

SKIDPROOF... KEEPING KIDS SAFE!

THE MARK CONSISTS OF STANDARD CHARACTERS WITHOUT CLAIM TO ANY PARTICULAR FONT, STYLE, SIZE, OR COLOR.

FOR HOSIERY (U.S. CLS. 22 AND 39).

FIRST USE 2-25-2010; IN COMMERCE 2-25-2010.

CLASS 25—(Continued).

4,016,703. RETAIL ROYALTY COMPANY, LAS VEGAS, NV. SN 77-982,224. PUB. 5-18-2010, FILED 12-18-2009.

little 77
by american eagle

OWNER OF U.S. REG. NOS. 3,033,841, 3,674,435, AND OTHERS.

THE MARK CONSISTS OF THE WORD "LITTLE" WITH THE NUMBER "77" FOLLOWED BY THE WORDS "BY AMERICAN EAGLE".

FOR CLOTHING, NAMELY, SWIMWEAR, BEACHWEAR, DRESSES, AND ROMPERS; HEADWEAR (U.S. CLS. 22 AND 39).

FIRST USE 7-0-2010; IN COMMERCE 7-0-2010.

4,016,718. BAEK, STEVEN, LA HABRA HEIGHTS, CA. SN 78-789,430. PUB. 8-29-2006, FILED 1-11-2006.

PRO

THE MARK CONSISTS OF THE TERM "PRO" OVER THE LETTER "T" IN THE FORM OF A T-SHIRT.

FOR CAPS; COATS; HATS; JACKETS; PANTS; SHIRTS; SOCKS; SWEAT SHIRTS; SWEATERS; T-SHIRTS (U.S. CLS. 22 AND 39).

FIRST USE 3-31-2004; IN COMMERCE 3-31-2004.

4,016,780. MST INFINITY, INC., PHOENIX, AZ. SN 85-026,686. PUB. 4-19-2011, FILED 4-29-2010.

100% WOMAN

THE MARK CONSISTS OF STANDARD CHARACTERS WITHOUT CLAIM TO ANY PARTICULAR FONT, STYLE, SIZE, OR COLOR.

NO CLAIM IS MADE TO THE EXCLUSIVE RIGHT TO USE "WOMAN", APART FROM THE MARK AS SHOWN.

FOR KNIT SHIRTS; WEARABLE GARMENTS AND CLOTHING, NAMELY, SHIRTS, HATS; OUTER JACKETS; SHORTS (U.S. CLS. 22 AND 39).

FIRST USE 2-15-2011; IN COMMERCE 2-15-2011.

CLASS 25—(Continued).

4,016,798. MAGASCHONI APPAREL GROUP, INC., NEW YORK, NY. SN 85-034,706. PUB. 10-5-2010, FILED 5-10-2010.

EXPOSITE BY MAGASCHONI

THE MARK CONSISTS OF STANDARD CHARACTERS WITHOUT CLAIM TO ANY PARTICULAR FONT, STYLE, SIZE, OR COLOR.

OWNER OF U.S. REG. NOS. 2,187,617, 2,995,722, AND 3,109,938.

FOR CLOTHING, NAMELY, SKIRTS, DRESSES, PANTS, JACKETS, SWEATERS, TOPS, BLAZERS (U.S. CLS. 22 AND 39);

FIRST USE 10-28-2010; IN COMMERCE 10-28-2010.

4,016,864. ENERGY INNOVATES MOTION, INC., PALM BEACH GARDENS, FL. SN 85-053,842. PUB. 10-26-2010, FILED 6-3-2010.

Live to win

THE MARK CONSISTS OF STANDARD CHARACTERS WITHOUT CLAIM TO ANY PARTICULAR FONT, STYLE, SIZE, OR COLOR.

FOR FOOTWEAR; HATS; JACKETS; JERSEYS; POLO SHIRTS; SHIRTS; SHORTS; SOCKS; SWEAT BANDS; SWEAT PANTS (U.S. CLS. 22 AND 39).

FIRST USE 6-1-2011; IN COMMERCE 6-1-2011.

4,016,871. BRUSH FOOTWEAR, LLC, NATRONA HEIGHTS, PA. SN 85-055,717. PUB. 11-2-2010, FILED 6-6-2010.



THE MARK CONSISTS OF CURVED BRUSHED STROKES FORMING LOWER CASE LETTER "B".

FOR FOOTWEAR (U.S. CLS. 22 AND 39).
FIRST USE 2-26-2010; IN COMMERCE 2-26-2010.

CLASS 25—(Continued).

4,016,875. KINGLY COMMONER LLC, BEAVERTON, OR. SN 85-057,791. PUB. 11-2-2010, FILED 6-8-2010.



THE MARK CONSISTS OF A BACKWARDS "K" SHARING A BORDER WITH THE LETTER "C" UNDERNEATH A CROWN.

FOR SHIRTS (U.S. CLS. 22 AND 39).

FIRST USE 8-31-2010; IN COMMERCE 8-31-2010.

4,016,879. HOP, RAFAEL COHEN, MEXICO CITY, MEXICO. SN 85-058,938. PUB. 11-2-2010, FILED 6-9-2010.

NATALIE ENCIENDE TU ALEGRIA

THE MARK CONSISTS OF STANDARD CHARACTERS WITHOUT CLAIM TO ANY PARTICULAR FONT, STYLE, SIZE, OR COLOR.

THE ENGLISH TRANSLATION OF "NATALIE ENCIENDE TU ALEGRIA" IN THE MARK IS "NATALIE GLOWS YOUR HAPPINESS".

FOR CLOTHING, NAMELY, DRESSES AND GOWNS; FOOTWEAR; HEADWEAR, NAMELY, VEILS; DRESS SHIELDS; DRESSING GOWNS; SKIRTS; LADIES' UNDERWEAR; LONG UNDERWEAR; THERMAL UNDERWEAR; UNDERWEAR, NAMELY, THONGS; UNDERWEAR; WOVEN OR KNITTED UNDERWEAR; PANTIES; LINGERIE; MATERNITY LINGERIE; ADHESIVE BRAS; BRAS (U.S. CLS. 22 AND 39).

FIRST USE 3-31-2009; IN COMMERCE 3-31-2009.

CLASS 25—(Continued).

4,016,889. WATSON, JILL, DBATHE PAMPERED BRIDE, SAN CLEMENTE, CA. SN 85-060,657. PUB. 11-16-2010, FILED 6-11-2010.

SAVE THE VEIL

THE MARK CONSISTS OF STANDARD CHARACTERS WITHOUT CLAIM TO ANY PARTICULAR FONT, STYLE, SIZE, OR COLOR.

NO CLAIM IS MADE TO THE EXCLUSIVE RIGHT TO USE "VEIL", APART FROM THE MARK AS SHOWN.

FOR BRIDAL ACCESSORIES, NAMELY, DECORATIVE WEIGHTS FOR ATTACHMENT TO A VEIL TO PREVENT SUCH FROM BLOWING IN THE WIND (U.S. CLS. 22 AND 39).

FIRST USE 6-30-2011; IN COMMERCE 6-30-2011.

CLASS 25—(Continued).

4,016,923. STADERINI, MARCO, 50063 FIGLINE VALDARNO, ITALY. SN 85-067,823. PUB. 11-16-2010, FILED 6-21-2010.

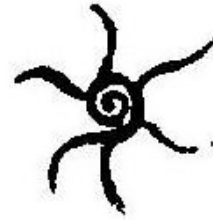

MASQUENADA

THE MARK CONSISTS OF THE WORD "MASQUENADA" IN STYLIZED FONT AND A STYLIZED SPIRAL DESIGN SURROUNDED BY SIX SOLAR RAYS.

FOR BEACH FOOTWEAR; BEACHWEAR; HATS; SUN-DRESSES; SWIMMING COSTUMES (U.S. CLS. 22 AND 39).

FIRST USE 7-30-2010; IN COMMERCE 7-30-2010.

4,016,896. GYPSY 05, INC., LOS ANGELES, CA. SN 85-062,435. PUB. 11-16-2010, FILED 6-14-2010.

GYPSYZ BY GYPSY 05

THE MARK CONSISTS OF STANDARD CHARACTERS WITHOUT CLAIM TO ANY PARTICULAR FONT, STYLE, SIZE, OR COLOR.

OWNER OF U.S. REG. NOS. 3,106,284 AND 3,642,608.

FOR APPAREL, NAMELY, SOCKS WORN AS SHOES (U.S. CLS. 22 AND 39).

FIRST USE 10-1-2010; IN COMMERCE 10-1-2010.

4,016,929. HALO INNOVATIONS, INC., MINNETONKA, MN. SN 85-068,746. PUB. 11-16-2010, FILED 6-22-2010.

ComfortLuxe

THE MARK CONSISTS OF STANDARD CHARACTERS WITHOUT CLAIM TO ANY PARTICULAR FONT, STYLE, SIZE, OR COLOR.

FOR FABRIC SOLD AS AN INTEGRAL COMPONENT OF FINISHED CHILDREN'S CLOTHING, NAMELY, INFANT WEAR, SLEEPWEAR, SHIRTS, ROMPERS, ONE PIECE GARMENTS, PANTS, JACKETS, JUMPERS; INFANT WEAR AND CLOTHING FOR CHILDREN AND TODDLERS, NAMELY, SLEEPWEAR, SHIRTS, ROMPERS, ONE PIECE GARMENTS, PANTS, JACKETS, JUMPERS (U.S. CLS. 22 AND 39).

FIRST USE 2-24-2011; IN COMMERCE 3-7-2011.

CLASS 25—(Continued).

4,016,941. LABORATORIOS DE MODA S.A. DE C.V, LEÓN, GUANAJUATO, MEXICO. SN 85-071,064. PUB. 11-16-2010, FILED 6-24-2010.



THE MARK CONSISTS OF AN ABSTRACT DESIGN WHOSE UPPER AREA LOOKS LIKE A HEART AND WHOSE LOWER AREA LOOKS LIKE A STYLIZED CAPITAL LETTER "M". THE DESIGN CONTAINS ADDITIONAL ABSTRACT DECORATIVE ELEMENTS. BENEATH THE DESIGN APPEAR THE WORDS "CORAZÓN DE MELÓN" IN STYLIZED LETTERS.

THE LITERAL TRANSLATION OF THE SPANISH PHRASE "CORAZÓN DE MELÓN" IS "HEART OF MELON". THIS IS A TERM OF ENDEARMENT IN SPANISH.

FOR BELTS; BLOUSES; HATS; PANTS; SHIRTS; SHOES; SNEAKERS; T-SHIRTS; TENNIS SHOES; UNDERWEAR (U.S. CLS. 22 AND 39).

FIRST USE 1-26-2006; IN COMMERCE 9-2-2009.

4,016,945. STRAWHUN, KELLI, CARLSBAD, CA, CA. AND STRAWHUN, DENNIS, CARLSBAD, CA, CA. SN 85-072,211. PUB. 4-12-2011, FILED 6-25-2010.

CLAN INEBRIATED GU DEOCH GU CAIRDEAN GU SPORS

THE MARK CONSISTS OF STANDARD CHARACTERS WITHOUT CLAIM TO ANY PARTICULAR FONT, STYLE, SIZE, OR COLOR.

THE ENGLISH TRANSLATION OF THE WORDS "GU DEOCH GU CAIRDEAN GU SPORS" IN THE MARK IS TO DRINK, TO FRIENDS, TO FUN.

FOR HOODED SWEAT SHIRTS; LONG-SLEEVED SHIRTS; SHIRTS; SHORT-SLEEVED OR LONG-SLEEVED T-SHIRTS; SHORT-SLEEVED SHIRTS; SWEAT SHIRTS; T-SHIRTS (U.S. CLS. 22 AND 39).

FIRST USE 10-11-2010; IN COMMERCE 10-11-2010.

CLASS 25—(Continued).

4,016,972. OLIVIA MILLER, INC, NEW YORK, NY. SN 85-079,830. PUB. 12-7-2010, FILED 7-7-2010.

OLIVIA MILLER GIRL

THE MARK CONSISTS OF STANDARD CHARACTERS WITHOUT CLAIM TO ANY PARTICULAR FONT, STYLE, SIZE, OR COLOR.

OWNER OF U.S. REG. NO. 2,805,469.

NO CLAIM IS MADE TO THE EXCLUSIVE RIGHT TO USE "GIRL", APART FROM THE MARK AS SHOWN.

THE NAME "OLIVIA MILLER" IDENTIFIES A LIVING INDIVIDUAL WHOSE CONSENT IS OF RECORD.

FOR GIRLS FOOTWEAR, NAMELY, SLIPPERS, SANDALS, FLIP FLOPS, BOOTS, ATHLETIC SHOES, SHOES, SNEAKERS (U.S. CLS. 22 AND 39).

FIRST USE 6-30-2011; IN COMMERCE 6-30-2011.

4,016,988. GALOOTGEAR, INC., VALENCIA, CA. SN 85-082,886. PUB. 12-7-2010, FILED 7-12-2010.

TAWNY TABREEZ

THE MARK CONSISTS OF STANDARD CHARACTERS WITHOUT CLAIM TO ANY PARTICULAR FONT, STYLE, SIZE, OR COLOR.

FOR BLOUSES; COATS; HOSIERY; JACKETS; PANTS; SHIRTS; SHOES; SKIRTS; SOCKS (U.S. CLS. 22 AND 39).

FIRST USE 2-9-2011; IN COMMERCE 2-9-2011.

4,016,999. CARROLL, BIME L, JACKSON, MS. SN 85-086,050. PUB. 12-14-2010, FILED 7-15-2010.

LIVE ENJOY INSPIRE

THE MARK CONSISTS OF STANDARD CHARACTERS WITHOUT CLAIM TO ANY PARTICULAR FONT, STYLE, SIZE, OR COLOR.

FOR APPAREL FOR DANCERS, NAMELY, TEE SHIRTS, SWEATSHIRTS, PANTS, LEGGINGS, SHORTS AND JACKETS; ATHLETIC APPAREL, NAMELY, SHIRTS, PANTS, JACKETS, FOOTWEAR, HATS AND CAPS, ATHLETIC UNIFORMS; CHILDREN'S AND INFANT'S APPAREL, NAMELY, JUMPERS, OVERALL SLEEPWEAR, PAJAMAS, ROMPERS AND ONE-PIECE GARMENTS (U.S. CLS. 22 AND 39).

FIRST USE 10-31-2010; IN COMMERCE 10-31-2010.

CLASS 25—(Continued).

4,017,025. BRUSH FOOTWEAR, LLC, NATRONA HEIGHTS, PA. SN 85-093,220. PUB. 11-2-2010, FILED 7-26-2010.

BRUSH

THE MARK CONSISTS OF STANDARD CHARACTERS WITHOUT CLAIM TO ANY PARTICULAR FONT, STYLE, SIZE, OR COLOR.

FOR FOOTWEAR (U.S. CLS. 22 AND 39).
FIRST USE 2-26-2010; IN COMMERCE 2-26-2010.

4,017,029. 2B.RYCH LLC, NEW YORK, NY. SN 85-095,586. PUB. 5-17-2011, FILED 7-29-2010.



OWNER OF U.S. REG. NO. 3,677,444.

THE MARK CONSISTS OF THE NUMERAL "2" IN STYLIZED FONT WITHIN A RECTANGLE WITH THREE CURVED CORNERS AND ONE RIGHT-ANGLE CORNER POSITIONED AT THE LOWER RIGHT SIDE ADJACENT TO A LOWER-CASE STYLIZED LETTER "B" AND PERIOD ALONGSIDE THE WORD "RYCH" IN STYLIZED FONT.

FOR WOMEN'S CLOTHING, NAMELY, SKIRTS, DRESSES, BLOUSES, T-SHIRTS, SWEATERS, JACKETS, BLAZERS, PANTS, SHORTS, VESTS AND COATS (U.S. CLS. 22 AND 39).

FIRST USE 1-0-2011; IN COMMERCE 1-0-2011.

CLASS 25—(Continued).

4,017,059. SANTILLANA, ANDY, SANTA ROSA, CA. SN 85-106,453. PUB. 1-25-2011, FILED 8-12-2010.



THE MARK CONSISTS OF THE STYLIZED TEXT "OUR * ANYTHING EVERYTHING".

FOR CLOTHING, NAMELY, SHIRTS, JACKETS, HOODED SWEATERS, AND HEADWEAR (U.S. CLS. 22 AND 39).

FIRST USE 2-25-2011; IN COMMERCE 2-25-2011.

4,017,062. ESCANTE, INC., SAN ANTONIO, TX. SN 85-106,804. PUB. 3-22-2011, FILED 8-13-2010.

LOLA INTIMATES

THE MARK CONSISTS OF STANDARD CHARACTERS WITHOUT CLAIM TO ANY PARTICULAR FONT, STYLE, SIZE, OR COLOR.

OWNER OF U.S. REG. NO. 3,822,194.

NO CLAIM IS MADE TO THE EXCLUSIVE RIGHT TO USE "INTIMATES", APART FROM THE MARK AS SHOWN. THE NAME "LOLA" DOES NOT IDENTIFY A LIVING INDIVIDUAL.

FOR WOMEN'S CLOTHING, NAMELY, LINGERIE (U.S. CLS. 22 AND 39).

FIRST USE 2-1-2011; IN COMMERCE 2-1-2011.

4,017,063. ESCANTE, INC., SAN ANTONIO, TX. SN 85-106,813. PUB. 3-22-2011, FILED 8-13-2010.

LOLA INTIMATES BY ESCANTE

THE MARK CONSISTS OF STANDARD CHARACTERS WITHOUT CLAIM TO ANY PARTICULAR FONT, STYLE, SIZE, OR COLOR.

OWNER OF U.S. REG. NO. 3,822,194.

NO CLAIM IS MADE TO THE EXCLUSIVE RIGHT TO USE "INTIMATES", APART FROM THE MARK AS SHOWN. THE NAME "LOLA" DOES NOT IDENTIFY A LIVING INDIVIDUAL.

FOR WOMEN'S CLOTHING, NAMELY, LINGERIE (U.S. CLS. 22 AND 39).

FIRST USE 2-1-2011; IN COMMERCE 2-1-2011.

CLASS 25—(Continued).

4,017,139. CARHARTT, INC., DEARBORN, MI. SN 85-138,363.
PUB. 3-8-2011, FILED 9-26-2010.

DURA-DRY

THE MARK CONSISTS OF STANDARD CHARACTERS WITHOUT CLAIM TO ANY PARTICULAR FONT, STYLE, SIZE, OR COLOR.

FOR JACKETS (U.S. CLS. 22 AND 39).
FIRST USE 6-1-2011; IN COMMERCE 6-1-2011.

4,017,149. OLIVIA MILLER, INC. NEW YORK, NY. SN 85-147,435. PUB. 11-23-2010, FILED 10-7-2010.

OWNER OF U.S. REG. NO. 2,805,469.
NO CLAIM IS MADE TO THE EXCLUSIVE RIGHT TO USE "GIRL", APART FROM THE MARK AS SHOWN.

THE NAME "OLIVIA MILLER" IDENTIFIES A LIVING INDIVIDUAL WHOSE CONSENT IS OF RECORD.

THE COLOR(S) MAGENTA, BROWN, YELLOW AND LIGHT MAGENTA IS/ARE CLAIMED AS A FEATURE OF THE MARK.

THE MARK CONSISTS OF THE WORDS "OLIVIA MILLER GIRL" IN A STYLIZED FORMAT WITH AN ABSTRACT BUTTERFLY AT ONE SIDE. THE "O" IN "OLIVIA", THE "M" IN "MILLER" AND "GIRL" ARE IN MAGENTA. THE "LIVIA" IN "OLIVIA" AND "ILLER" IN "MILLER" ARE IN BROWN. THE BUTTERFLY'S LEFT SIDE IS YELLOW, RIGHT SIDE IS LIGHT MAGENTA AND MIDDLE IS MAGENTA. THE WHITE IN THE MARK IS BACKGROUND AREA WHICH IS NOT A PART OF THE MARK.

FOR GIRLS FOOTWEAR, NAMELY, SLIPPERS, SANDALS, FLIP FLOPS, BOOTS, ATHLETIC SHOES, SHOES, SNEAKERS (U.S. CLS. 22 AND 39).

FIRST USE 6-30-2011; IN COMMERCE 6-30-2011.

CLASS 25—(Continued).

4,017,173. SANGUINE ENTERPRISES, LLC, SEVERNA PARK, MD. SN 85-158,694. PUB. 4-5-2011, FILED 10-22-2010.

THE MARK CONSISTS OF STYLIZED LETTERS SPELLING OUT "THE POSITIVE SPIN". THE LETTER "O" IN THE WORD "POSITIVE" HAS A PLUS SYMBOL IN THE CENTER WITH AN ARROW STARTING FROM THE LEFT SIDE OF THE PLUS SYMBOL MOVING NORTH. THE LETTER "S" IN THE WORD "SPIN" HAS AN ARROW IN IT THAT FORMS THE LOWER HALF OF THE LETTER "S".

FOR BASEBALL CAPS AND HATS; BELTS; BELTS FOR CLOTHING; BELTS MADE OUT OF CLOTH; BOARD SHORTS; BODY SHIRTS; BOTTOMS; BOXER BRIEFS; BOXER SHORTS; BRIEFS; BUTTON DOWN SHIRTS; BUTTON-FRONT ALOHA SHIRTS; CAMOUFLAGE SHIRTS; CAMP SHIRTS; CHILDREN'S AND INFANTS' CLOTH BIBS; CHILDREN'S CLOTH EATING BIBS; CLOTH BIBS; CLOTH BIBS FOR ADULT DINERS; CLOTHING FOR ATHLETIC USE, NAMELY, PADDED ELBOW COMPRESSION SLEEVES BEING PART OF AN ATHLETIC GARMENT; CLOTHING FOR ATHLETIC USE, NAMELY, PADDED PANTS; CLOTHING FOR ATHLETIC USE, NAMELY, PADDED SHIRTS; CLOTHING FOR ATHLETIC USE, NAMELY, PADDED SHORTS; CLOTHING, NAMELY, BASE LAYERS; CLOTHING, NAMELY, KHAKIS; CLOTHING, NAMELY, NECK TUBES; COLLARED SHIRTS; DRESS SHIRTS; DUSTERS; EYESHADES; FIGURE SKATING CLOTHING, NAMELY, SHIRTS; FISHING SHIRTS; FLEECE SHORTS; GLOVES AS CLOTHING; GOLF PANTS, SHIRTS AND SKIRTS; GOLF SHIRTS; GOLF SHORTS; GYM SHORTS; HATS; HATS FOR INFANTS, BABIES, TODDLERS AND CHILDREN; HEADBANDS FOR CLOTHING; HEADGEAR, NAMELY, CAPS; HOODED SWEAT SHIRTS; HOODS; HUNTING SHIRTS; INFANT AND TODDLER ONE PIECE CLOTHING; JACKETS; JERSEYS; KNIT SHIRTS; KNITTED UNDERWEAR; LADIES' UNDERWEAR; LEATHER BELTS; LONG-SLEEVED SHIRTS; MEN'S UNDERWEAR; MOISTURE-WICKING SPORTS SHIRTS; MUFFLERS; OPEN-NECKED SHIRTS; OVER SHIRTS; PANTIES; PANTIES, SHORTS AND BRIEFS; PARTS OF CLOTHING, NAMELY, GUSSETS FOR TIGHTS, GUSSETS FOR STOCKINGS, GUSSETS FOR BATHING SUITS, GUSSETS FOR UNDERWEAR, GUSSETS FOR LEOTARDS AND GUSSETS FOR FOOTLETS; PERSPIRATION ABSORBENT UNDERWEAR CLOTHING; POLO SHIRTS; RAIN HATS; RUGBY SHIRTS; RUGBY SHORTS; SHIRTS; SHIRTS AND SHORT-SLEEVED SHIRTS; SHIRTS AND SLIPS; SHIRTS FOR INFANTS, BABIES, TODDLERS AND CHILDREN; SHIRTS FOR SUITS; SHORT SETS; SHORT-SLEEVED OR LONG-SLEEVED T-SHIRTS; SHORT-SLEEVED SHIRTS; SHOULDER WRAPS; SHOULDER WRAPS FOR CLOTHING; SLEEP SHIRTS; SMALL HATS; SPORT SHIRTS; SPORTS SHIRTS; SPORTS SHIRTS WITH SHORT SLEEVES; SWEAT SHIRTS; SWEAT SHORTS; T-SHIRTS; TEE SHIRTS; THERMAL UNDERWEAR; THONGS; TIES; TOPS; TRIATHLON CLOTHING, NAMELY, TRIATHLON TIGHTS, TRIATHLON SHORTS, TRIATHLON SINGLET, TRIATHLON SHIRTS, TRIATHLON SUITS; TURTLE NECK SHIRTS; UNDERWEAR; UNDERWEAR, NAMELY, BOY SHORTS; WEARABLE GARMENTS AND CLOTHING, NAMELY, SHIRTS; WIND SHIRTS; WOMEN'S HATS AND HOODS; WOMEN'S UNDERWEAR; WOOLLY HATS; WOVEN OR KNITTED UNDERWEAR; WRAPS; YOGA SHIRTS (U.S. CLS. 22 AND 39).

FIRST USE 8-29-2010; IN COMMERCE 8-29-2010.

CLASS 25—(Continued).

4,017,176. A. H. SCHREIBER COMPANY, INC., NEW YORK, NY. SN 85-161,376. PUB. 4-19-2011, FILED 10-26-2010.

BLEU|ROD BEATTIE

THE MARK CONSISTS OF STANDARD CHARACTERS WITHOUT CLAIM TO ANY PARTICULAR FONT, STYLE, SIZE, OR COLOR.

THE NAME(S), PORTRAIT(S), AND/OR SIGNATURE(S) SHOWN IN THE MARK IDENTIFIES A LIVING INDIVIDUAL, WHOSE CONSENT(S) TO REGISTER IS MADE OF RECORD.

THE ENGLISH TRANSLATION OF "BLEU" IN THE MARK IS "BLUE".

FOR COVERUPS; SWIMSUITS (U.S. CLS. 22 AND 39). FIRST USE 6-24-2011; IN COMMERCE 6-24-2011.

4,017,198. SCULLY SPORTSWEAR, INC., OXNARD, CA. SN 85-170,687. PUB. 5-3-2011, FILED 11-5-2010.

THE CANTINA COLLECTION

THE MARK CONSISTS OF STANDARD CHARACTERS WITHOUT CLAIM TO ANY PARTICULAR FONT, STYLE, SIZE, OR COLOR.

NO CLAIM IS MADE TO THE EXCLUSIVE RIGHT TO USE "COLLECTION", APART FROM THE MARK AS SHOWN.

FOR CLOTHING, NAMELY, TOPS, BOTTOMS, SHIRTS, PANTS, BLOUSES, SKIRTS, DRESSES, VESTS, JACKETS AND COATS (U.S. CLS. 22 AND 39).

FIRST USE 1-31-2011; IN COMMERCE 3-31-2011.

4,017,230. ME TOO LLC, NEW YORK, NY. SN 85-193,593. PUB. 5-3-2011, FILED 12-8-2010.

Me Too SOHO

THE MARK CONSISTS OF STANDARD CHARACTERS WITHOUT CLAIM TO ANY PARTICULAR FONT, STYLE, SIZE, OR COLOR.

OWNER OF U.S. REG. NO. 3,757,658.

NO CLAIM IS MADE TO THE EXCLUSIVE RIGHT TO USE "SOHO", APART FROM THE MARK AS SHOWN.

FOR WOMEN'S AND CHILDREN'S FOOTWEAR, NAMELY, BOOTS AND SANDALS (U.S. CLS. 22 AND 39).

FIRST USE 2-1-2011; IN COMMERCE 2-1-2011.

CLASS 25—(Continued).

4,017,248. GEOFFREY, LLC, WAYNE, NJ. SN 85-217,927. PUB. 4-19-2011, FILED 1-14-2011.



OWNER OF U.S. REG. NOS. 3,468,568, 3,621,107, AND OTHERS.

NO CLAIM IS MADE TO THE EXCLUSIVE RIGHT TO USE "BABY", APART FROM THE MARK AS SHOWN.

THE MARK CONSISTS OF A KOALA BEAR ABOVE THE WORDS "KOALA BABY".

FOR CLOTHING FOR INFANTS AND CHILDREN, NAMELY, BABY BIBS NOT OF PAPER, BODY SUITS, BONNETS, BOOTIES, BOTTOMS, CAPS, CARDIGANS, COATS, COORDINATING SETS COMPRISING TOPS AND BOTTOMS, COVERALLS, CREEPERS, DRESSES, HATS, JACKETS, JEANS, JOGGING SUITS, JUMPERS, JUMPSUITS, LAYETTE SETS COMPRISING SHORTALLS AND TOPS, LAYETTE SETS COMPRISING TOPS AND PANTS, LAYETTE SETS COMPRISING GOWNS AND CAPS, LAYETTE SETS COMPRISING OVERALLS AND TOPS, LAYETTE SETS COMPRISING CARDIGANS AND PANTS, LAYETTE SETS COMPRISING CREEPERS AND PANTS, LAYETTE SETS COMPRISING CARDIGANS, TOPS AND PANTS, LAYETTES, MITTENS, OVERALL SETS COMPRISING OVERALLS AND TOPS, OVERALLS, PANTS, RAIN COATS, RAIN JACKETS, RAINWEAR, ROMPERS, SANDALS, SHIRTS, SHOES, SOFT SHOES, SHORT SETS, SHORTALL SETS COMPRISING SHORTALLS AND TOPS, SHORTALLS, SHORTS, SKIRTS, SKORTS, SLEEPWEAR, SNOW SUITS, SOCKS, SWEAT SHIRTS, SWEAT PANTS, SWEATERS, SWIMSUITS, SWIMWEAR SETS COMPRISING SWIMSUITS AND COVERUPS, SWIMWEAR SETS COMPRISING SWIM TRUNKS AND COVERUPS, TEE-SHIRTS, TIGHTS, TOPS, AND WIND RESISTANT JACKETS (U.S. CLS. 22 AND 39).

FIRST USE 0-0-1999; IN COMMERCE 0-0-1999.

4,017,260. G-III LEATHER FASHIONS, INC., NEW YORK, NY. SN 85-975,420. PUB. 11-2-2010, FILED 3-31-2010.

JESSICA H

THE MARK CONSISTS OF STANDARD CHARACTERS WITHOUT CLAIM TO ANY PARTICULAR FONT, STYLE, SIZE, OR COLOR.

OWNER OF U.S. REG. NOS. 1,525,866, 3,642,426, AND 3,719,346.

CLASS 25—(Continued).

THE NAME(S), PORTRAIT(S), AND/OR SIGNATURE(S) SHOWN IN THE MARK DOES NOT IDENTIFY A PARTICULAR LIVING INDIVIDUAL.

FOR CLOTHING, NAMELY, DRESSES (U.S. CLS. 22 AND 39).

FIRST USE 9-0-2010; IN COMMERCE 9-0-2010.

CLASS 26—FANCY GOODS

4,016,284. MARION D. HOLMES, LAURELTON, NY. SN 77-615,314. PUB. 10-13-2009, FILED 11-16-2008.

KARMA'S A BITCH

THE MARK CONSISTS OF STANDARD CHARACTERS WITHOUT CLAIM TO ANY PARTICULAR FONT, STYLE, SIZE, OR COLOR.

FOR ORNAMENTAL NOVELTY BADGES; ORNAMENTAL NOVELTY PINS (U.S. CLS. 37, 39, 40, 42 AND 50).

FIRST USE 3-3-2010; IN COMMERCE 3-11-2010.

4,016,338. PROFESSIONAL RODEO COWBOYS ASSOCIATION, INC., COLORADO SPRINGS, CO. SN 77-745,058. PUB. 8-3-2010, FILED 5-27-2009.

THE MARK CONSISTS OF A STYLIZED DRAWING OF THE LETTERS "PRCA PRORODEO".

FOR CLOTH, EMBROIDERED, OR ORNAMENTAL PATCHES FOR CLOTHING (U.S. CLS. 37, 39, 40, 42 AND 50).

FIRST USE 10-30-2008; IN COMMERCE 10-30-2008.

4,016,791. VON SCHACK, REGINA, NEW YORK, NY. SN 85-033,546. PUB. 10-5-2010, FILED 5-7-2010.

GINA MADE IT

THE MARK CONSISTS OF STANDARD CHARACTERS WITHOUT CLAIM TO ANY PARTICULAR FONT, STYLE, SIZE, OR COLOR.

FOR BARRETTES; HAIR BANDS; HAIR BOWS; HAIR CLIPS; ORNAMENTS FOR THE HAIR (U.S. CLS. 37, 39, 40, 42 AND 50).

FIRST USE 5-29-2010; IN COMMERCE 11-8-2010.

CLASS 26—(Continued).

4,017,065. HARRISON, SUSAN L., LUBBOCK, TX. SN 85-107,400. PUB. 11-16-2010, FILED 8-13-2010.

BEBLESSED

THE MARK CONSISTS OF STANDARD CHARACTERS WITHOUT CLAIM TO ANY PARTICULAR FONT, STYLE, SIZE, OR COLOR.

FOR WIGS (U.S. CLS. 37, 39, 40, 42 AND 50).
FIRST USE 11-24-2010; IN COMMERCE 11-24-2010.

CLASS 27—FLOOR COVERINGS

4,016,360. 2 DYNAMIC, INC., SAN DIEGO, CA. SN 77-765,618. PUB. 11-10-2009, FILED 6-22-2009.

WISTERIA LANE

THE MARK CONSISTS OF STANDARD CHARACTERS WITHOUT CLAIM TO ANY PARTICULAR FONT, STYLE, SIZE, OR COLOR.

FOR VINYL FLOOR COVERINGS (U.S. CLS. 19, 20, 37, 42 AND 50).

FIRST USE 10-9-2009; IN COMMERCE 6-30-2011.

4,016,451. ORGANICALLY GROWN GROUP, LLC, SANTA BARBARA, CA. SN 77-878,970. PUB. 10-19-2010, FILED 11-23-2009.

GREENOLOGY

THE MARK CONSISTS OF STANDARD CHARACTERS WITHOUT CLAIM TO ANY PARTICULAR FONT, STYLE, SIZE, OR COLOR.

FOR AREA RUGS, BATH MATS, CARPETING, CARPETS, RUGS, COVERINGS FOR EXISTING FLOORS, DOOR MATS, FABRIC BATH MATS, FLOOR COVERINGS, FLOOR MATS, TEXTILE BATH MATS, TEXTILE FLOOR MATS FOR USE IN THE HOME (U.S. CLS. 19, 20, 37, 42 AND 50).

FIRST USE 6-9-2011; IN COMMERCE 6-9-2011.

CLASS 27—(Continued).

4,016,458. ORGANICALLY GROWN GROUP, LLC, SANTA BARBARA, CA. SN 77-882,679. PUB. 10-26-2010, FILED 11-30-2009.

ORGANICALLY GROWN

THE MARK CONSISTS OF STANDARD CHARACTERS WITHOUT CLAIM TO ANY PARTICULAR FONT, STYLE, SIZE, OR COLOR.

OWNER OF U.S. REG. NOS. 2,187,996 AND 3,542,589. SEC. 2(F).

FOR AREA RUGS, BATH MATS, CARPETING, CARPETS, RUGS, COVERINGS FOR EXISTING FLOORS, DOOR MATS, FABRIC BATH MATS, FLOOR COVERINGS, FLOOR MATS, TEXTILE BATH MATS, TEXTILE FLOOR MATS FOR USE IN THE HOME (U.S. CLS. 19, 20, 37, 42 AND 50).

FIRST USE 6-9-2011; IN COMMERCE 6-9-2011.

4,016,507. PRODUCT BLISS, LLC, FORMERLY WRUG, LLC, BEVERLY HILLS, CA. SN 77-896,066. PUB. 5-18-2010, FILED 12-17-2009.

RUGGABLE

THE MARK CONSISTS OF STANDARD CHARACTERS WITHOUT CLAIM TO ANY PARTICULAR FONT, STYLE, SIZE, OR COLOR.

FOR AREA RUGS; CARPET UNDERLAYS, NAMELY, RUG GRIPPERS; CARPETS AND RUGS; CARPETS, RUGS, MATS AND MATTING, LINOLEUM FOR COVERING EXISTING FLOORS; ORIENTAL NON-WOVEN RUGS (MOSEN); RUGS (U.S. CLS. 19, 20, 37, 42 AND 50).

FIRST USE 9-1-2009; IN COMMERCE 6-7-2011.

4,016,841. NOVALIS HOLDINGS LIMITED, WAN CHAI, HONG KONG. SN 85-047,979. PUB. 10-26-2010, FILED 5-26-2010.

NovaClic

THE MARK CONSISTS OF STANDARD CHARACTERS WITHOUT CLAIM TO ANY PARTICULAR FONT, STYLE, SIZE, OR COLOR.

FOR FLOORING PRODUCTS, NAMELY, HARD SOLID VINYL COVERINGS FOR FLOORS (U.S. CLS. 19, 20, 37, 42 AND 50).

FIRST USE 1-15-2011; IN COMMERCE 1-15-2011.

CLASS 27—(Continued).

4,016,868. INTERFACE, INC., ATLANTA, GA. SN 85-054,870. PUB. 12-7-2010, FILED 6-4-2010.

INTERFACE STROLL

THE MARK CONSISTS OF STANDARD CHARACTERS WITHOUT CLAIM TO ANY PARTICULAR FONT, STYLE, SIZE, OR COLOR.

OWNER OF U.S. REG. NO. 1,001,087. FOR CARPETING (U.S. CLS. 19, 20, 37, 42 AND 50). FIRST USE 8-31-2010; IN COMMERCE 8-31-2010.

CLASS 28—TOYS AND SPORTING GOODS

4,016,296. CARPENTER, ELIZABETH S, NEW YORK, NY. SN 77-644,770. PUB. 4-28-2009, FILED 1-7-2009.

STRINGO!

THE MARK CONSISTS OF STANDARD CHARACTERS WITHOUT CLAIM TO ANY PARTICULAR FONT, STYLE, SIZE, OR COLOR.

FOR BOARD GAMES; CARD GAMES; JIGSAW AND MANIPULATIVE PUZZLES; PLAYING CARDS AND CARD GAMES; PUZZLES; TABLETOP GAMES (U.S. CLS. 22, 23, 38 AND 50).

FIRST USE 2-13-2011; IN COMMERCE 2-13-2011.

4,016,321. ZOBMONDO!! ENTERTAINMENT LLC, LOS ANGELES, CA. SN 77-708,057. PUB. 3-23-2010, FILED 4-6-2009.

Party Gras

THE MARK CONSISTS OF STANDARD CHARACTERS WITHOUT CLAIM TO ANY PARTICULAR FONT, STYLE, SIZE, OR COLOR.

NO CLAIM IS MADE TO THE EXCLUSIVE RIGHT TO USE "PARTY", APART FROM THE MARK AS SHOWN.

THE ENGLISH TRANSLATION OF "GRAS" IN THE MARK IS "FAT".

FOR PARTY GAMES, NAMELY, BOARD GAMES AND CARD GAMES (U.S. CLS. 22, 23, 38 AND 50).

FIRST USE 6-1-2011; IN COMMERCE 6-1-2011.

CLASS 28—(Continued).

4,016,332. RUSSELL BRANDS, LLC, ALEXANDER CITY, AL. SN 77-733,407. PUB. 9-29-2009, FILED 5-11-2009.

XTREME  **MOTION**

THE MARK CONSISTS OF THE WORDS "XTREME" AND "MOTION" SEPARATED BY THREE PARALLEL DIAGONAL LINES OF INCREASING THICKNESS.

FOR PROTECTIVE ATHLETIC CUPS (U.S. CLS. 22, 23, 38 AND 50).

FIRST USE 10-31-2010; IN COMMERCE 10-31-2010.

4,016,354. SMARTY ANTS, INC., ROSS, CA. SN 77-759,819. PUB. 11-10-2009, FILED 6-15-2009.

SMARTY ANTS

THE MARK CONSISTS OF STANDARD CHARACTERS WITHOUT CLAIM TO ANY PARTICULAR FONT, STYLE, SIZE, OR COLOR.

FOR EDUCATIONAL TOYS FOR TEACHING READING, LANGUAGE AND OTHER EARLY CHILDHOOD EDUCATION SUBJECTS, NAMELY, INTERACTIVE STUFFED TOYS; ELECTRONIC EDUCATIONAL GAME MACHINES FOR CHILDREN; ELECTRONIC GAMES FOR THE TEACHING OF CHILDREN; ELECTRONIC LEARNING TOYS; STUFFED DOLLS AND ANIMALS; ACCESSORIES FOR STUFFED DOLLS AND ANIMALS (U.S. CLS. 22, 23, 38 AND 50).

FIRST USE 11-16-2010; IN COMMERCE 11-16-2010.

4,016,418. LOCKHEED MARTIN CORPORATION, BETHESDA, MD. SN 77-850,597. PUB. 8-31-2010, FILED 10-16-2009.

F-35

THE MARK CONSISTS OF STANDARD CHARACTERS WITHOUT CLAIM TO ANY PARTICULAR FONT, STYLE, SIZE, OR COLOR.

OWNER OF U.S. REG. NOS. 2,826,332, 2,830,735, AND OTHERS.

FOR TOYS AND PLAYTHINGS, NAMELY, ACTION FIGURES, SCALE MODEL AIRPLANES, TOY AIRPLANES, RADIO-CONTROLLED MODEL AIRPLANES, KITES, PLAY SETS CONSISTING OF A TOY AIRPLANE AND ACCESSORIES THEREFORE MODEL AIRPLANE KITS, GOLF BALLS (U.S. CLS. 22, 23, 38 AND 50).

FIRST USE 12-31-2009; IN COMMERCE 12-31-2009.

CLASS 28—(Continued).

4,016,423. TRAN, DIANE, DBA OSOTUFFDOGTOYS.COM, SAN JOSE, CA. SN 77-861,034. PUB. 4-20-2010, FILED 10-30-2009.

 **OSOTUFF**

THE MARK CONSISTS OF THE STYLIZED WORD "OSOTUFF" WITH A STYLIZED DEPICTION OF A DOG TO THE LEFT OF THE WORDING. THE DOG HAS BITTEN OFF THE UPPER LEFT PORTION OF THE FIRST "O" IN "OSOTUFF".

FOR DOG TOYS; PET TOYS; PET TOYS MADE OF ROPE (U.S. CLS. 22, 23, 38 AND 50).

FIRST USE 1-1-2011; IN COMMERCE 3-13-2011.

4,016,462. MARIO LEMIEUX, PITTSBURGH, PA. SN 77-883,928. PUB. 10-19-2010, FILED 12-2-2009.

MLX

THE MARK CONSISTS OF STANDARD CHARACTERS WITHOUT CLAIM TO ANY PARTICULAR FONT, STYLE, SIZE, OR COLOR.

FOR ICE SKATES (U.S. CLS. 22, 23, 38 AND 50).

FIRST USE 8-0-2010; IN COMMERCE 8-0-2010.

4,016,486. PARLEY ENTERTAINMENT, INC., RALEIGH, NC. SN 77-891,788. PUB. 5-4-2010, FILED 12-11-2009.

**IF ALL THE WORLD'S A
STAGE, WE'RE ALL STARS**

THE MARK CONSISTS OF STANDARD CHARACTERS WITHOUT CLAIM TO ANY PARTICULAR FONT, STYLE, SIZE, OR COLOR.

FOR GAMES, NAMELY, PARLOR GAMES, PARTY GAMES, CARD GAMES AND BOARD GAMES (U.S. CLS. 22, 23, 38 AND 50).

FIRST USE 3-29-2011; IN COMMERCE 3-29-2011.

CLASS 28—(Continued).

4,016,488. FNG AMAZING, LLC, JOHNSTON, IA. SN 77-892,312. PUB. 5-11-2010, FILED 12-13-2009.

Fetch-N-Go

THE MARK CONSISTS OF STANDARD CHARACTERS WITHOUT CLAIM TO ANY PARTICULAR FONT, STYLE, SIZE, OR COLOR.

FOR DOG TOYS (U.S. CLS. 22, 23, 38 AND 50).
FIRST USE 3-12-2011; IN COMMERCE 3-12-2011.

4,016,555. PAUL JOSEPH GORODNICK, GAINESVILLE, VA.
SN 77-919,000. PUB. 6-15-2010, FILED 1-25-2010.

FORE!GOLF

THE MARK CONSISTS OF STANDARD CHARACTERS WITHOUT CLAIM TO ANY PARTICULAR FONT, STYLE, SIZE, OR COLOR.

FOR PLAYING CARDS (U.S. CLS. 22, 23, 38 AND 50).
FIRST USE 1-3-2010; IN COMMERCE 1-3-2010.

4,016,582. MATTEL, INC., EL SEGUNDO, CA. SN 77-934,338.
PUB. 6-22-2010, FILED 2-12-2010.

CATRA

THE MARK CONSISTS OF STANDARD CHARACTERS WITHOUT CLAIM TO ANY PARTICULAR FONT, STYLE, SIZE, OR COLOR.

FOR TOYS, GAMES AND PLAYTHINGS, NAMELY, TOY ACTION FIGURES AND ACCESSORIES THEREFOR (U.S. CLS. 22, 23, 38 AND 50).
FIRST USE 5-16-2011; IN COMMERCE 5-16-2011.

CLASS 28—(Continued).

4,016,588. XXX-STREAM TACKLE, INC., PORT RICHEY, FL.
SN 77-936,604. PUB. 7-13-2010, FILED 2-16-2010.

MICRO WAVE

THE MARK CONSISTS OF STANDARD CHARACTERS WITHOUT CLAIM TO ANY PARTICULAR FONT, STYLE, SIZE, OR COLOR.

FOR LINE GUIDE FOR FISHING ROD (U.S. CLS. 22, 23, 38 AND 50).
FIRST USE 2-25-2011; IN COMMERCE 2-25-2011.

4,016,599. BARNETT OUTDOORS, LLC, TARPON SPRINGS, FL.
SN 77-941,448. PUB. 7-13-2010, FILED 2-22-2010.

GAMECRUSHER

THE MARK CONSISTS OF STANDARD CHARACTERS WITHOUT CLAIM TO ANY PARTICULAR FONT, STYLE, SIZE, OR COLOR.

FOR ARCHERY EQUIPMENT, NAMELY, ARCHERY BOWS AND CROSSBOWS (U.S. CLS. 22, 23, 38 AND 50).
FIRST USE 4-19-2011; IN COMMERCE 4-19-2011.

4,016,639. BDFFL ENTERPRISES, LLC, CHARLOTTE, MI.
SN 77-956,045. PUB. 8-3-2010, FILED 3-10-2010.



THE MARK CONSISTS OF TWO UPPER CASE LETTERS "T", BOTH IN AACHEN OR SIMILAR FONT, ONE BEING POSITIONED TO THE LEFT AND SLIGHTLY OFFSET FROM THE OTHER, WITH A STAR-BURST BETWEEN THE TWO UPPER CASE LETTERS.

FOR BOARD GAMES (U.S. CLS. 22, 23, 38 AND 50).
FIRST USE 4-15-2011; IN COMMERCE 4-15-2011.

CLASS 28—(Continued).

4,016,676. PETER FISH & CO. PTY. LTD, GORDON, NSW, AUSTRALIA. SN 77-982,093. PUB. 10-19-2010, FILED 3-23-2010.



OWNER OF U.S. REG. NO. 2,971,286.

THE MARK CONSISTS OF THE WORD "FISH" IN STYLIZED FORM IN THE SHAPE OF A FISH.

FOR ACTION FIGURES AND ACCESSORIES THEREFOR; TOY AIRPLANES; PLAY FIGURES; TOY SPINNING TOPS; YO-YOS; BUBBLE LIQUID SOLUTION; BUBBLE BLOWING TOYS; FLYING BOOMERANG-TYPE TOYS; POSEABLE TOY FIGURES, INCLUDING MAGNETIC TOY FIGURES; TOY BALL SEGMENTS THAT STORE AND RELEASE KINETIC ENERGY TO CAUSE THE BALL TO REACT WHEN THE ENERGY IS RELEASED (U.S. CLS. 22, 23, 38 AND 50).

FIRST USE 3-31-2010; IN COMMERCE 3-31-2010.

4,016,707. DISNEY ENTERPRISES, INC., BURBANK, CA. SN 77-982,250. PUB. 11-16-2010, FILED 12-21-2009.

PHINEAS AND FERB

THE MARK CONSISTS OF STANDARD CHARACTERS WITHOUT CLAIM TO ANY PARTICULAR FONT, STYLE, SIZE, OR COLOR.

OWNER OF U.S. REG. NOS. 3,578,149 AND 3,610,415.

FOR ACTION FIGURES AND ACCESSORIES THEREFOR; BOARD GAMES; CARD GAMES; BALLOONS; BASEBALLS; DOLL PLAYSETS; ELECTRIC ACTION TOYS; EQUIPMENT SOLD AS A UNIT FOR PLAYING CARD GAMES; HAND-HELD UNITS FOR PLAYING ELECTRONIC GAMES OTHER THAN THOSE ADAPTED FOR USE WITH AN EXTERNAL DISPLAY SCREEN OR MONITOR; JIGSAW PUZZLES; PARLOR GAMES; PARTY FAVORS IN THE NATURE OF SMALL TOYS; PARTY GAMES; PLAYING CARDS; PLUSH TOYS; SKATEBOARDS; SQUEEZE TOYS; STUFFED TOYS; TALKING TOYS; TOY ACTION FIGURES AND ACCESSORIES THEREFOR; TOY VEHICLES; TOY FIGURES; TOY BANKS; TOY TRUCKS; WIND-UP TOYS (U.S. CLS. 22, 23, 38 AND 50).

FIRST USE 3-31-2010; IN COMMERCE 3-31-2010.

CLASS 28—(Continued).

4,016,709. LIONS GATE ENTERTAINMENT, INC., SANTA MONICA, CA. SN 77-982,305. PUB. 9-21-2010, FILED 1-21-2010.



THE COLOR(S) BLACK, RED AND WHITE IS/ARE CLAIMED AS A FEATURE OF THE MARK.

THE MARK CONSISTS OF THE IMAGE OF A SMOKING MAN. THE BACK OF HIS HEAD AND HIS SUIT ARE BLACK. HIS COLLAR AND CUFFS ARE WHITE. AS IS THE CIGARETTE. BELOW THE IMAGE IS THE WORDING "MAD MEN" ON A BLACK RECTANGULAR BACKGROUND, WITH THE "MAD" PORTION IN RED AND THE "MEN" PORTION IN WHITE.

FOR ACTION FIGURES; BOARD GAMES; JIGSAW AND MANIPULATIVE PUZZLES; PLAYING CARDS (U.S. CLS. 22, 23, 38 AND 50).

FIRST USE 7-1-2010; IN COMMERCE 7-1-2010.

4,016,716. MATTEL, INC., EL SEGUNDO, CA. SN 78-738,932. PUB. 5-20-2008, FILED 10-24-2005.

JAYLA

THE MARK CONSISTS OF STANDARD CHARACTERS WITHOUT CLAIM TO ANY PARTICULAR FONT, STYLE, SIZE, OR COLOR.

FOR TOYS, GAMES AND PLAYTHINGS, NAMELY, DOLLS, DOLL CLOTHING AND DOLL ACCESSORIES, TOY FIGURES AND ACCESSORIES THEREFOR (U.S. CLS. 22, 23, 38 AND 50).

FIRST USE 6-22-2011; IN COMMERCE 6-22-2011.

4,016,772. DILLON, THOMAS W, SAN TAN VALLEY, AZ. SN 85-023,587. PUB. 11-2-2010, FILED 4-26-2010.

gocce ball

THE MARK CONSISTS OF STANDARD CHARACTERS WITHOUT CLAIM TO ANY PARTICULAR FONT, STYLE, SIZE, OR COLOR.

NO CLAIM IS MADE TO THE EXCLUSIVE RIGHT TO USE "BALL", APART FROM THE MARK AS SHOWN.

CLASS 28—(Continued).

THE WORDING "GOCCE" HAS NO MEANING IN A FOREIGN LANGUAGE.

FOR COLORED GOLF BALLS AND PRINTED INSTRUCTION MANUALS SOLD AS A UNIT FOR INDOOR AND OUTDOOR GOLF CHIPPING, PITCHING AND PUTTING GAME (U.S. CLS. 22, 23, 38 AND 50).

FIRST USE 5-9-2010; IN COMMERCE 6-1-2010.

4,016,840. HALL, MARRIANNE, ANN ARBOR, MI. SN 85-047,428. PUB. 10-26-2010, FILED 5-25-2010.

MORBID SKATEBOARDS

THE MARK CONSISTS OF STANDARD CHARACTERS WITHOUT CLAIM TO ANY PARTICULAR FONT, STYLE, SIZE, OR COLOR.

NO CLAIM IS MADE TO THE EXCLUSIVE RIGHT TO USE "SKATEBOARDS", APART FROM THE MARK AS SHOWN.

FOR SKATEBOARDS (U.S. CLS. 22, 23, 38 AND 50).
FIRST USE 4-0-2011; IN COMMERCE 4-0-2011.

4,016,883. MATTEL, INC., EL SEGUNDO, CA. SN 85-059,265. PUB. 11-16-2010, FILED 6-10-2010.

SPEED & SPLASH DUEL

THE MARK CONSISTS OF STANDARD CHARACTERS WITHOUT CLAIM TO ANY PARTICULAR FONT, STYLE, SIZE, OR COLOR.

FOR TOY VEHICLE TRACK SETS AND ACCESSORIES THEREFOR; BATH TOYS (U.S. CLS. 22, 23, 38 AND 50).
FIRST USE 10-12-2010; IN COMMERCE 10-12-2010.

4,016,904. RIDEMAKERZ, LLC, IRVINE, CA. SN 85-064,665. PUB. 11-16-2010, FILED 6-16-2010.

SNAP N GO

THE MARK CONSISTS OF STANDARD CHARACTERS WITHOUT CLAIM TO ANY PARTICULAR FONT, STYLE, SIZE, OR COLOR.

FOR TOY VEHICLES AND ACCESSORIES THEREFOR (U.S. CLS. 22, 23, 38 AND 50).
FIRST USE 5-16-2011; IN COMMERCE 5-16-2011.

CLASS 28—(Continued).

4,016,922. HOWARD, CECILIA, BEDFORD, NH. SN 85-067,819. PUB. 11-16-2010, FILED 6-21-2010.

RhymeABeans

THE MARK CONSISTS OF STANDARD CHARACTERS WITHOUT CLAIM TO ANY PARTICULAR FONT, STYLE, SIZE, OR COLOR.

FOR STUFFED AND PLUSH TOYS (U.S. CLS. 22, 23, 38 AND 50).
FIRST USE 5-17-2011; IN COMMERCE 5-17-2011.

4,016,996. MATTEL, INC., EL SEGUNDO, CA. SN 85-085,810. PUB. 12-14-2010, FILED 7-15-2010.

LOCKS OF LOOKS

THE MARK CONSISTS OF STANDARD CHARACTERS WITHOUT CLAIM TO ANY PARTICULAR FONT, STYLE, SIZE, OR COLOR.

FOR DOLLS, DOLL CLOTHING AND DOLL ACCESSORIES (U.S. CLS. 22, 23, 38 AND 50).
FIRST USE 5-18-2011; IN COMMERCE 5-18-2011.

4,017,013. MATTEL, INC., EL SEGUNDO, CA. SN 85-090,457. PUB. 12-14-2010, FILED 7-22-2010.

DEXY

THE MARK CONSISTS OF STANDARD CHARACTERS WITHOUT CLAIM TO ANY PARTICULAR FONT, STYLE, SIZE, OR COLOR.

FOR TOY VEHICLES AND ACCESSORIES THEREFOR (U.S. CLS. 22, 23, 38 AND 50).
FIRST USE 2-7-2011; IN COMMERCE 2-7-2011.

CLASS 28—(Continued).

4,017,014. MATTEL, INC., EL SEGUNDO, CA. SN 85-090,459.
PUB. 12-14-2010, FILED 7-22-2010.

SWISHER

THE MARK CONSISTS OF STANDARD CHARACTERS WITHOUT CLAIM TO ANY PARTICULAR FONT, STYLE, SIZE, OR COLOR.

FOR TOY VEHICLES AND ACCESSORIES THEREFOR (U.S. CLS. 22, 23, 38 AND 50).

FIRST USE 2-7-2011; IN COMMERCE 2-7-2011.

4,017,055. COUNCIL GAMES, GRAND JUNCTION, CO. SN 85-105,561. PUB. 1-25-2011, FILED 8-11-2010.



NO CLAIM IS MADE TO THE EXCLUSIVE RIGHT TO USE "GAMES", APART FROM THE MARK AS SHOWN.

THE MARK CONSISTS OF THE STYLIZED TEXT "C G COUNCIL GAMES".

FOR CARD GAMES (U.S. CLS. 22, 23, 38 AND 50).
FIRST USE 7-1-2010; IN COMMERCE 7-1-2010.

4,017,064. SPONGEZZ INC., TORONTO, ONTARIO, CANADA. SN 85-106,933. PUB. 11-16-2010, FILED 8-13-2010.



NO CLAIM IS MADE TO THE EXCLUSIVE RIGHT TO USE "SHAPES", APART FROM THE MARK AS SHOWN.

THE COLOR(S) LIME GREEN, BLACK AND PINK. IS/ARE CLAIMED AS A FEATURE OF THE MARK.

THE MARK CONSISTS OF THE STYLIZED WORDING "SHAPES 2 GO" WITH "SHAPES" IN LIME GREEN AND

CLASS 28—(Continued).

TRIMMED IN BLACK AND "2 GO" IN PINK AND TRIMMED IN BLACK AND WITH THE TAIL OF "GO" FORMING AN ARROW POINTING TO THE RIGHT. ABOVE THE WORDING ARE TWO BOXES. THE BOX ON THE LEFT IS LIME GREEN AND TRIMMED IN BLACK WITH A BLACK BOW ON TOP. THE BOX ON THE RIGHT IS PINK AND TRIMMED IN BLACK AND IS OPEN. COMING OUT OF THE TOP OF THE OPENED PINK BOX ARE A BLACK BOW AND A PARTIALLY-EXPOSED BLACK HEART.

FOR TOY FOAM NOVELTY ITEMS, NAMELY, FOAM FINGERS AND HANDS, FOAM BATH MITTS, FOAM SHAPES IN NATURE OF ABC LETTERS, HEARTS, AND SMILEY FACES, AND FOAM CHRISTMAS TREE ORNAMENTS (U.S. CLS. 22, 23, 38 AND 50).

FIRST USE 11-15-2010; IN COMMERCE 11-15-2010.

4,017,111. BARE HEART BUDDY, LLC, HENDERSON, NV. SN 85-126,557. PUB. 2-22-2011, FILED 9-10-2010.



THE COLOR(S) RED AND WHITE IS/ARE CLAIMED AS A FEATURE OF THE MARK.

THE MARK CONSISTS OF TWO OVERLAPPING HEART-SHAPED OUTLINES IN RED COLOR. THE FIRST HEART IS CENTERED AND VERTICALLY ALIGNED. THE SECOND SMALLER HEART IS TILTED IN TO THE UPPER RIGHT, WHEREAS THE UPPER-LEFT PORTION OF THE HEART OVERLAPS WITH THE FIRST HEART. THE TOP LEFT LOBE OF THE FIRST LARGER HEART CONTAINS THE TERM "BARE" IN WHITE COLOR, WHEREAS THE TOP LEFT LOBE OF THE SECOND SMALLER HEART CONTAINS THE TERM "HEARTS" IN WHITE COLOR. THE WHITE BACKGROUND IS NOT CLAIMED AS A FEATURE OF THE MARK.

FOR STUFFED TOY ANIMALS (U.S. CLS. 22, 23, 38 AND 50).

FIRST USE 11-1-2010; IN COMMERCE 4-20-2011.

4,017,228. MOOSETACHE GAMES, LLC, BERKELEY, CA. SN 85-189,819. PUB. 4-19-2011, FILED 12-2-2010.

HIKE

THE MARK CONSISTS OF STANDARD CHARACTERS WITHOUT CLAIM TO ANY PARTICULAR FONT, STYLE, SIZE, OR COLOR.

FOR CARD GAMES (U.S. CLS. 22, 23, 38 AND 50).
FIRST USE 5-16-2011; IN COMMERCE 5-16-2011.

CLASS 28—(Continued).

4,017,238. STARMARK PET PRODUCTS, INC., HUTTO, TX.
SN 85-200,753. PUB. 3-29-2011, FILED 12-17-2010.



NO CLAIM IS MADE TO THE EXCLUSIVE RIGHT TO USE "PROFESSIONAL GRADE" OR "PET GEAR", APART FROM THE MARK AS SHOWN.

THE MARK CONSISTS OF THE WORDING "PROFESSIONAL GRADE PET GEAR" IN A STYLIZED FONT AND A DESIGN THAT CONSISTS OF THREE CONCENTRIC CIRCLES AND A FIVE-POINTED STAR WITH FOUR SMALLER OVALS SURROUNDING THE TOPMOST POINT OF THE STAR IN THE SMALLEST CIRCLE, AND TWO ADDITIONAL FIVE-POINTED STARS BETWEEN THE WORDS.

FOR SPORTING GOODS AND GAME EQUIPMENT, NAMELY, PET TOYS USED FOR PLAY, FOR TRAINING AND DURING COMPETITIONS AND DOG SHOWS (U.S. CLS. 22, 23, 38 AND 50).

FIRST USE 6-1-2011; IN COMMERCE 6-1-2011.

4,017,251. KOLCRAFT ENTERPRISES, INC., CHICAGO, IL.
SN 85-234,748. PUB. 4-19-2011, FILED 2-4-2011.

TURTLETOT

THE MARK CONSISTS OF STANDARD CHARACTERS WITHOUT CLAIM TO ANY PARTICULAR FONT, STYLE, SIZE, OR COLOR.

FOR BABY MULTIPLE ACTIVITY TOYS (U.S. CLS. 22, 23, 38 AND 50).

FIRST USE 6-1-2011; IN COMMERCE 6-1-2011.

CLASS 28—(Continued).

4,017,261. X PLUS PRODUCTS, INC., BRADENTON, FL. SN 85-975,440. PUB. 3-15-2011, FILED 11-29-2010.

COMBATANT COMMAND

THE MARK CONSISTS OF STANDARD CHARACTERS WITHOUT CLAIM TO ANY PARTICULAR FONT, STYLE, SIZE, OR COLOR.

FOR EQUIPMENT SOLD AS A UNIT FOR PLAYING BOARD GAMES (U.S. CLS. 22, 23, 38 AND 50).

FIRST USE 6-1-2011; IN COMMERCE 6-1-2011.

4,017,268. EASEBON SERVICES LIMITED, KWUN TONG, HONG KONG. SN 85-975,476. PUB. 11-9-2010, FILED 6-10-2010.

FLOATZONE

THE MARK CONSISTS OF STANDARD CHARACTERS WITHOUT CLAIM TO ANY PARTICULAR FONT, STYLE, SIZE, OR COLOR.

FOR WATER TOYS AND WATER SQUIRTING TOYS (U.S. CLS. 22, 23, 38 AND 50).

FIRST USE 10-18-2010; IN COMMERCE 10-18-2010.

CLASS 29—MEATS AND PROCESSED FOODS

4,016,161. GRANDMA HOERNER'S FOODS, INC., ALMA, KS. SN 76-702,459. PUB. 9-14-2010, FILED 4-12-2010.

WE'RE ALL ABOUT WHAT MATTERS

THE MARK CONSISTS OF STANDARD CHARACTERS WITHOUT CLAIM TO ANY PARTICULAR FONT, STYLE, SIZE, OR COLOR.

FOR APRICOT APPLESAUCE, CANDY APPLESAUCE, CINNAMON APPLESAUCE, CRANBERRY APPLESAUCE, RASPBERRY APPLESAUCE, RASPBERRY JALAPENO APPLESAUCE, STRAWBERRY APPLESAUCE (U.S. CL. 46).

FIRST USE 9-8-2007; IN COMMERCE 9-8-2007.

CLASS 29—(Continued).

4,016,372. GLANBIA PLC, KILKENNY, IRELAND. SN 77-784,926. PUB. 6-29-2010, FILED 7-20-2009.

OPTISOL

THE MARK CONSISTS OF STANDARD CHARACTERS WITHOUT CLAIM TO ANY PARTICULAR FONT, STYLE, SIZE, OR COLOR.

FOR MILK-BASED PROTEIN, WHEY PROTEIN, AND FLAX SEED PROTEIN FOR USE AS A FOOD ADDITIVE (U.S. CL. 46).

FIRST USE 6-0-2009; IN COMMERCE 6-0-2009.

4,016,447. GORTON'S INC., GLOUCESTER, MA. SN 77-877,596. PUB. 5-18-2010, FILED 11-20-2009.

TWICE A WEEK, TWICE AS SMART.

THE MARK CONSISTS OF STANDARD CHARACTERS WITHOUT CLAIM TO ANY PARTICULAR FONT, STYLE, SIZE, OR COLOR.

FOR FROZEN SEAFOOD; PRE-PACKAGED ENTREES CONSISTING PRIMARILY OF SEAFOOD (U.S. CL. 46).

FIRST USE 4-4-2011; IN COMMERCE 4-4-2011.

4,016,561. BLUE RIBBON IP, LLC, NEW YORK, NY. SN 77-922,596. PUB. 5-11-2010, FILED 1-28-2010.

SIMPLE SLIDERS

THE MARK CONSISTS OF STANDARD CHARACTERS WITHOUT CLAIM TO ANY PARTICULAR FONT, STYLE, SIZE, OR COLOR.

NO CLAIM IS MADE TO THE EXCLUSIVE RIGHT TO USE "SLIDERS", APART FROM THE MARK AS SHOWN.

FOR FROZEN CHICKEN ENTREES; FROZEN CHICKEN BURGERS (U.S. CL. 46).

FIRST USE 8-5-2010; IN COMMERCE 8-5-2010.

CLASS 29—(Continued).

4,016,601. OCEAN TRAWLERS HOLDING LTD., WAN CHAI, HONG KONG. SN 77-942,311. PUB. 1-18-2011, FILED 2-23-2010.

Ocean Trawlers

OWNER OF U.S. REG. NO. 2,895,299.

THE COLOR(S) BLACK AND BLUE IS/ARE CLAIMED AS A FEATURE OF THE MARK.

THE MARK CONSISTS OF THE TERM "OCEAN TRAWLERS" IN BLACK, STYLIZED FONT WITH A BLUE CIRCLE DESIGN SUPERSCRIPED TO THE LETTER "S" IN THE MARK. A DRAWING OF A BLUE FISH IS CONTAINED WITHIN THE CIRCULAR SUPERSCRIPED DESIGN.

FOR FROZEN AND FRESH SEAFOOD (U.S. CL. 46).

FIRST USE 3-0-2010; IN COMMERCE 3-0-2010.

4,016,797. GEORGIA NUT COMPANY, SKOKIE, IL. SN 85-034,602. PUB. 9-28-2010, FILED 5-10-2010.

CLUSTER BUSTERS

THE MARK CONSISTS OF STANDARD CHARACTERS WITHOUT CLAIM TO ANY PARTICULAR FONT, STYLE, SIZE, OR COLOR.

NO CLAIM IS MADE TO THE EXCLUSIVE RIGHT TO USE "CLUSTER", APART FROM THE MARK AS SHOWN.

FOR PROCESSED NUTS AND FRUITS IN BITE SIZED BAR FORM (U.S. CL. 46).

FIRST USE 8-2-2010; IN COMMERCE 8-2-2010.

4,016,886. LAND O'LAKES, INC., ARDEN HILLS, MN. SN 85-060,367. PUB. 11-9-2010, FILED 6-11-2010.

HILLDALE

THE MARK CONSISTS OF STANDARD CHARACTERS WITHOUT CLAIM TO ANY PARTICULAR FONT, STYLE, SIZE, OR COLOR.

OWNER OF U.S. REG. NO. 923,944.

FOR CHEESE (U.S. CL. 46).

FIRST USE 6-30-2010; IN COMMERCE 6-30-2010.

CLASS 29—(Continued).

4,016,918. KRAFT FOODS GLOBAL BRANDS LLC, NORTH-FIELD, IL. SN 85-067,418. PUB. 10-26-2010, FILED 6-21-2010.

ALASKAN WILDERNESS BLEND

THE MARK CONSISTS OF STANDARD CHARACTERS WITHOUT CLAIM TO ANY PARTICULAR FONT, STYLE, SIZE, OR COLOR.

NO CLAIM IS MADE TO THE EXCLUSIVE RIGHT TO USE "BLEND", APART FROM THE MARK AS SHOWN.

FOR SNACK MIX CONSISTING OF DEHYDRATED FRUIT AND PROCESSED NUTS (U.S. CL. 46).

FIRST USE 1-0-2011; IN COMMERCE 1-0-2011.

4,016,948. GREEK BOYS CHOICE, INC., TARPON SPRINGS, FL. SN 85-073,095. PUB. 12-28-2010, FILED 6-28-2010.

Hellenic Harvest

THE MARK CONSISTS OF STANDARD CHARACTERS WITHOUT CLAIM TO ANY PARTICULAR FONT, STYLE, SIZE, OR COLOR.

NO CLAIM IS MADE TO THE EXCLUSIVE RIGHT TO USE "HELLENIC", APART FROM THE MARK AS SHOWN.

FOR OLIVE OILS; PROCESSED OLIVES; PROCESSED PEPPERS (U.S. CL. 46).

FIRST USE 5-15-2011; IN COMMERCE 6-1-2011.

4,017,070. QINGDAO NINE-ALLIANCE GROUP CO.,LTD, LAIXI CITY, QINGDAO, CHINA. SN 85-109,862. PUB. 3-8-2011, FILED 8-17-2010.



THE MARK CONSISTS OF STYLIZED LETTERS "JL" INSIDE A CIRCLE WITH HORIZONTAL BANDS, AND OUTSIDE ARE CHINESE CHARACTERS.

CLASS 29—(Continued).

THE NON-LATIN CHARACTERS IN THE MARK TRANSLITERATE TO JIULIAN AND THIS MEANS NINE-ALLIANCE IN ENGLISH.

FOR CHICKEN CROQUETTES; CRUSTACEANS; FISH; HAM; MEAT; MEAT JELLIES; POULTRY, NOT LIVE; PRESERVED VEGETABLES; SAUSAGES; TINNED MEAT (U.S. CL. 46).

FIRST USE 2-22-2011; IN COMMERCE 2-28-2011.

4,017,078. KWIK TRIP, INC., LA CROSSE, WI. SN 85-111,410. PUB. 2-1-2011, FILED 8-19-2010.

KITCHEN CRAVINGS

THE MARK CONSISTS OF STANDARD CHARACTERS WITHOUT CLAIM TO ANY PARTICULAR FONT, STYLE, SIZE, OR COLOR.

OWNER OF U.S. REG. NO. 3,562,302.

FOR MEAT; MEATBALLS; PROCESSED MEAT, NAMELY, COCKTAIL WIENERS; MEAT-BASED SNACK FOODS; PORK; PULLED PORK; POULTRY; CHICKEN; CHICKEN WINGS; PACKAGED OR PREPARED MEALS CONSISTING PRIMARILY OF MEAT, POULTRY AND/OR VEGETABLES; FOOD PACKAGE COMBINATIONS CONSISTING PRIMARILY OF MEAT AND/OR CHEESE (U.S. CL. 46).

FIRST USE 1-2-2008; IN COMMERCE 1-2-2008.

4,017,113. SAVORY CREATIONS INTERNATIONAL, SAN MATEO, CA. SN 85-127,405. PUB. 3-29-2011, FILED 9-10-2010.



THE COLOR(S) YELLOW, WHITE, GRAY AND RUST IS/ ARE CLAIMED AS A FEATURE OF THE MARK.

THE MARK CONSISTS OF A ROTUND CHEF OUTLINED IN BLACK DRESSED IN WHITE JACKET WITH BLACK BUTTONS AND A WHITE HAT WITH GRAY PANTS DELIVERING A STEAMING BOWL IN THE COLOR RUST IN AN OUTSTRETCHED ARM ALL OUTLINED IN BLACK WITH A YELLOW BACKGROUND.

FOR FOOD CONCENTRATES OF CHICKEN, MEAT AND SEAFOOD AS INGREDIENTS FOR SAUCES, BROTHS AND STOCKS FOR HUMAN CONSUMPTION (U.S. CL. 46).

FIRST USE 11-9-2004; IN COMMERCE 3-28-2005.

CLASS 29—(Continued).

4,017,129. TAYLOR FRESH FOODS, INC., SALINAS, CA. SN 85-133,946. PUB. 3-1-2011, FILED 9-20-2010.

NATURE'S GARDEN SALADS

THE MARK CONSISTS OF STANDARD CHARACTERS WITHOUT CLAIM TO ANY PARTICULAR FONT, STYLE, SIZE, OR COLOR.

NO CLAIM IS MADE TO THE EXCLUSIVE RIGHT TO USE "GARDEN SALADS", APART FROM THE MARK AS SHOWN.

FOR SALAD MIXES CONSISTING PRIMARILY OF PRE-CUT LETTUCE AND PRE-CUT SPINACH (U.S. CL. 46).

FIRST USE 11-0-2010; IN COMMERCE 11-0-2010.

4,017,136. KARTJANG, INC., JACKSONVILLE, FL. SN 85-136,956. PUB. 3-22-2011, FILED 9-23-2010.

**ONE
HOT NUT**

NO CLAIM IS MADE TO THE EXCLUSIVE RIGHT TO USE "HOT NUT", APART FROM THE MARK AS SHOWN.

FOR PROCESSED PEANUTS (U.S. CL. 46).

FIRST USE 9-23-2010; IN COMMERCE 9-23-2010.

4,017,199. JONAS WHITE CATERING LLC, NEW YORK, NY. SN 85-171,590. PUB. 3-29-2011, FILED 11-8-2010.

JONAS WHITE'S BUTTER

THE MARK CONSISTS OF STANDARD CHARACTERS WITHOUT CLAIM TO ANY PARTICULAR FONT, STYLE, SIZE, OR COLOR.

NO CLAIM IS MADE TO THE EXCLUSIVE RIGHT TO USE "BUTTER", APART FROM THE MARK AS SHOWN.

THE NAME(S), PORTRAIT(S), AND/OR SIGNATURE(S) SHOWN IN THE MARK DOES NOT IDENTIFY A PARTICULAR LIVING INDIVIDUAL.

FOR BUTTER, NAMELY, COMPOUND BUTTER (U.S. CL. 46).

FIRST USE 5-5-2011; IN COMMERCE 5-5-2011.

CLASS 29—(Continued).

4,017,220. THE NEST COLLECTIVE, INC., EMERYVILLE, CA. SN 85-183,581. PUB. 5-3-2011, FILED 11-23-2010.



THE MARK CONSISTS OF A SPECIAL FORM DRAWING OF A LIQUID SPILLING, WITH THE WORD "MASHUPS" IN THE CENTER.

FOR FRUIT AND VEGETABLE PUREES (U.S. CL. 46).

FIRST USE 1-31-2011; IN COMMERCE 1-31-2011.

CLASS 30—STAPLE FOODS

4,016,163. LATE JULY SNACKS LLC, BARNSTABLE, MA. SN 76-704,603. PUB. 2-8-2011, FILED 9-22-2010.

DUDE RANCH

THE MARK CONSISTS OF STANDARD CHARACTERS WITHOUT CLAIM TO ANY PARTICULAR FONT, STYLE, SIZE, OR COLOR.

FOR MULTIGRAIN-BASED SNACK FOODS, NAMELY, FLAVORED MULTIGRAIN CHIPS (U.S. CL. 46).

FIRST USE 10-31-2010; IN COMMERCE 10-31-2010.

4,016,164. LATE JULY SNACKS LLC, BARNSTABLE, MA. SN 76-704,623. PUB. 2-22-2011, FILED 9-23-2010.

LATE JULY

THE MARK CONSISTS OF STANDARD CHARACTERS WITHOUT CLAIM TO ANY PARTICULAR FONT, STYLE, SIZE, OR COLOR.

OWNER OF U.S. REG. NOS. 2,795,563 AND 3,425,067. FOR MULTIGRAIN-BASED SNACK FOODS, NAMELY, FLAVORED MULTIGRAIN CHIPS (U.S. CL. 46).

FIRST USE 10-31-2010; IN COMMERCE 10-31-2010.

CLASS 30—(Continued).

4,016,211. HOSTESS BRANDS, INC., IRVING, TX. SN 77-325,871. PUB. 4-22-2008, FILED 11-9-2007.



OWNER OF U.S. REG. NOS. 126,368, 3,260,896, AND OTHERS.

THE COLOR(S) RED, BLUE, WHITE AND GREY IS/ARE CLAIMED AS A FEATURE OF THE MARK.

THE MARK CONSISTS OF THE WORD "HOSTESS" IN BLUE WITHIN A RED OVAL RING. THE "H" OF "HOSTESS" PARTIALLY EXTENDING OUT OF THE BORDER OF THE OVAL, AND A RED HEART ON THE UPPER PART OF THE OVAL AND SLIGHTLY OFF-CENTERED FROM THE MIDPOINT. THE COLOR WHITE APPEARS IN THE BACKGROUND. THE COLOR GREY APPEARS IN THE SHADOWS OF THE WORDING "HOSTESS".

FOR FROZEN CONFECTIONS (U.S. CL. 46).
FIRST USE 7-1-2011; IN COMMERCE 7-1-2011.

4,016,212. HOSTESS BRANDS, INC., IRVING, TX. SN 77-326,054. PUB. 4-22-2008, FILED 11-9-2007.

TWINKIES

THE MARK CONSISTS OF STANDARD CHARACTERS WITHOUT CLAIM TO ANY PARTICULAR FONT, STYLE, SIZE, OR COLOR.

OWNER OF U.S. REG. NOS. 717,273 AND 1,040,186.
FOR FROZEN CONFECTIONS (U.S. CL. 46).
FIRST USE 7-1-2011; IN COMMERCE 7-1-2011.

4,016,213. HOSTESS BRANDS, INC., IRVING, TX. SN 77-326,995. PUB. 6-16-2009, FILED 11-12-2007.

DING DONGS

THE MARK CONSISTS OF STANDARD CHARACTERS WITHOUT CLAIM TO ANY PARTICULAR FONT, STYLE, SIZE, OR COLOR.

OWNER OF U.S. REG. NOS. 669,059, 1,158,278, AND 2,265,139.
FOR FROZEN CONFECTIONS (U.S. CL. 46).
FIRST USE 7-1-2011; IN COMMERCE 7-1-2011.

CLASS 30—(Continued).

4,016,214. HOSTESS BRANDS, INC., IRVING, TX. SN 77-327,318. PUB. 4-29-2008, FILED 11-12-2007.

SUZY Q'S

THE MARK CONSISTS OF STANDARD CHARACTERS WITHOUT CLAIM TO ANY PARTICULAR FONT, STYLE, SIZE, OR COLOR.

OWNER OF U.S. REG. NO. 738,321.
FOR FROZEN CONFECTIONS (U.S. CL. 46).
FIRST USE 7-1-2011; IN COMMERCE 7-1-2011.

4,016,239. HOSTESS BRANDS, INC., IRVING, TX. SN 77-364,688. PUB. 4-29-2008, FILED 1-4-2008.



OWNER OF U.S. REG. NOS. 717,273 AND 1,040,186.
THE COLOR(S) YELLOW, WHITE, BROWN, BLUE, BLACK AND RED IS/ARE CLAIMED AS A FEATURE OF THE MARK.

THE MARK CONSISTS OF A SMILING CARICATURE OF A SNACK CAKE ASTRIDE A DEPICTION OF A SNACK CAKE. THE DEPICTION OF THE SNACK CAKE IS YELLOW WITH WHITE FILLING. THE CARICATURE ASTRIDE THE SNACK CAKE HAS A BASE COLOR OF YELLOW WITH BLACK ARMS AND LEGS, WEARING BROWN BOOTS, GLOVES AND HAT, WITH A BLUE BANDANNA AND BLUE HATBAND. THE EYES ARE WHITE WITH BLACK PUPILS, THE MOUTH IS OPEN WITH WHITE TEETH AND RED TONGUE SHOWING. PART OF THE CARICATURE'S RIGHT GLOVED HAND AND MOST OF ITS RIGHT LEG ARE HIDDEN BY THE SNACK CAKE. THE LEFT ARM IS RAISED, PALM OUTWARD.

FOR FROZEN CONFECTIONS (U.S. CL. 46).
FIRST USE 7-6-2011; IN COMMERCE 7-6-2011.

CLASS 30—(Continued).

4,016,270. STANDARD FOODS CORPORATION, TAIPEI 106, TAIWAN. SN 77-491,563. PUB. 10-28-2008, FILED 6-5-2008.

OATSGHETTI

THE MARK CONSISTS OF STANDARD CHARACTERS WITHOUT CLAIM TO ANY PARTICULAR FONT, STYLE, SIZE, OR COLOR.

FOR NOODLES, SPAGHETTI, PASTA, MACARONI (U.S. CL. 46).

FIRST USE 4-3-2011; IN COMMERCE 4-3-2011.

4,016,273. U.S. VENTURE, INC., APPLETON, WI. SN 77-529,063. PUB. 12-16-2008, FILED 7-23-2008.



NO CLAIM IS MADE TO THE EXCLUSIVE RIGHT TO USE "PIZZA", APART FROM THE MARK AS SHOWN.

THE COLOR(S) RED, YELLOW, AND BLACK IS/ARE CLAIMED AS A FEATURE OF THE MARK.

THE COLOR BLACK APPEARS IN THE WORDING "PIE GUYS PIZZA", IN THE SHADOWING OF "PIE GUYS", AND IN THE CRUST, SLICE LINES, AND PEPPERONI OUTLINES IN THE PIZZA. THE COLOR YELLOW OCCURS IN THE INNER OUTLINING OF THE WORDING "PIE GUYS", AND IN THE BODY OF THE PIZZA. THE COLOR RED APPEARS IN THE OUTER OUTLINING OF THE WORDING "PIE GUYS" AND THE PIZZA.

FOR PIZZA (U.S. CL. 46).

FIRST USE 6-1-2011; IN COMMERCE 6-1-2011.

4,016,359. MORRIS NATIONAL, INC., AZUSA, CA. SN 77-762,273. PUB. 11-3-2009, FILED 6-17-2009.

MORE THAN JUST A NUT!

THE MARK CONSISTS OF STANDARD CHARACTERS WITHOUT CLAIM TO ANY PARTICULAR FONT, STYLE, SIZE, OR COLOR.

FOR CHOCOLATE AND CANDY (U.S. CL. 46).
FIRST USE 3-21-2011; IN COMMERCE 3-21-2011.

CLASS 30—(Continued).

4,016,439. MARGARET H. BITLER, DBA NOTTI TOFFEE, NEW YORK, NY. SN 77-871,709. PUB. 5-11-2010, FILED 11-12-2009.

NOTTI TOFFEE

THE MARK CONSISTS OF STANDARD CHARACTERS WITHOUT CLAIM TO ANY PARTICULAR FONT, STYLE, SIZE, OR COLOR.

NO CLAIM IS MADE TO THE EXCLUSIVE RIGHT TO USE "TOFFEE", APART FROM THE MARK AS SHOWN.

THE ENGLISH TRANSLATION OF "NOTTI" IN THE MARK IS "NIGHTS".

FOR CANDY (U.S. CL. 46).

FIRST USE 11-20-2009; IN COMMERCE 11-20-2009.

4,016,714. MARS, INCORPORATED, MCLEAN, VA. SN 78-622,144. PUB. 4-3-2007, FILED 5-4-2005.



THE COLOR(S) RED, WHITE AND BLUE IS/ARE CLAIMED AS A FEATURE OF THE MARK.

THE MARK CONSISTS OF A PARALLELOGRAM WITH THE COLOR BLUE INSIDE THE PARALLELOGRAM. THE COLORS WHITE AND RED LINE THE OUTSIDE OF THE PARALLELOGRAM.

FOR CONFECTIONERY PRODUCTS, NAMELY, CANDY (U.S. CL. 46).

FIRST USE 5-31-2009; IN COMMERCE 5-31-2009.

4,016,734. MOMMY DOCTORS BAKERY, THE, ROANOKE, VA. SN 85-005,831. PUB. 11-23-2010, FILED 4-4-2010.

milkin' cookies

NO CLAIM IS MADE TO THE EXCLUSIVE RIGHT TO USE "COOKIES", APART FROM THE MARK AS SHOWN.

THE COLOR(S) BROWN AND WHITE IS/ARE CLAIMED AS A FEATURE OF THE MARK.

THE MARK CONSISTS OF THE WORDS "MILKIN' COOKIES" IN A BROWN LOWER CASE FONT, WITH BROWN DOTS ON A WHITE BACKGROUND CENTERED WITHIN EACH OF THE LETTER "O" IN THE WORD "COOKIES".

FOR COOKIES (U.S. CL. 46).

FIRST USE 4-15-2010; IN COMMERCE 4-15-2010.

CLASS 30—(Continued).

4,016,788. GENERAL MILLS, INC., MINNEAPOLIS, MN. SN 85-032,639. PUB. 12-7-2010, FILED 5-7-2010.

DECADENT SUPREME

THE MARK CONSISTS OF STANDARD CHARACTERS WITHOUT CLAIM TO ANY PARTICULAR FONT, STYLE, SIZE, OR COLOR.

NO CLAIM IS MADE TO THE EXCLUSIVE RIGHT TO USE "SUPREME", APART FROM THE MARK AS SHOWN. FOR CAKE MIXES (U.S. CL. 46). FIRST USE 7-19-2010; IN COMMERCE 7-19-2010.

4,016,809. SMITHER FAMILY KITCHEN LLC, HOUSTON, TX. SN 85-038,878. PUB. 10-19-2010, FILED 5-14-2010.

Dillapeño

THE MARK CONSISTS OF STANDARD CHARACTERS WITHOUT CLAIM TO ANY PARTICULAR FONT, STYLE, SIZE, OR COLOR.

THE WORDING "DILLAPEÑO" HAS NO MEANING IN A FOREIGN LANGUAGE. FOR RELISH (U.S. CL. 46). FIRST USE 5-1-2009; IN COMMERCE 5-1-2009.

4,016,846. GUIMOND, BRUCE, HERMON, ME. SN 85-049,046. PUB. 11-9-2010, FILED 5-27-2010.



NO CLAIM IS MADE TO THE EXCLUSIVE RIGHT TO USE "BANGOR'S HISTORIC SANDWICHES" AND "SANDWICH", APART FROM THE MARK AS SHOWN.

THE COLOR(S) GREEN AND BLACK IS/ARE CLAIMED AS A FEATURE OF THE MARK.

THE MARK CONSISTS OF A GREEN OVAL OUTLINED IN BLACK WITH THE PHRASE "BANGOR'S HISTORIC SANDWICHES" IN GREEN AND THE WORD "SANDWICH" BELOW IN GREEN. INSIDE THE OVAL IS THE STYLIZED PHRASE "THE LEGACY" IN BLACK WITH A SANDWICH BELOW OUTLINED IN BLACK.

FOR MEAT-BASED SANDWICHES (U.S. CL. 46). FIRST USE 5-17-2010; IN COMMERCE 5-17-2010.

CLASS 30—(Continued).

4,016,851. LACY, AUBREY, LAPLACE, LA. SN 85-050,398. PUB. 11-9-2010, FILED 5-28-2010.

ERMA & AL'S DIABETIC FRIENDLY

THE MARK CONSISTS OF STANDARD CHARACTERS WITHOUT CLAIM TO ANY PARTICULAR FONT, STYLE, SIZE, OR COLOR.

OWNER OF U.S. REG. NO. 3,568,484. NO CLAIM IS MADE TO THE EXCLUSIVE RIGHT TO USE "DIABETIC FRIENDLY", APART FROM THE MARK AS SHOWN.

FOR FOOD SEASONING (U.S. CL. 46). FIRST USE 2-5-2011; IN COMMERCE 2-5-2011.

4,016,930. G.R.A.M.M. GRUPPO ALIMENTARE MEDITERRANEO MILO S.R.L., PALOMBAIO - BITONTO, ITALY. SN 85-068,815. PUB. 11-23-2010, FILED 6-22-2010.

MELIORA

THE MARK CONSISTS OF STANDARD CHARACTERS WITHOUT CLAIM TO ANY PARTICULAR FONT, STYLE, SIZE, OR COLOR.

FOR BREAD STICKS; CRACKERS; CROUTONS; DRIED PASTA; FRESH PASTA (U.S. CL. 46). FIRST USE 12-31-2010; IN COMMERCE 12-31-2010.

4,016,947. ENTERAL HEALTH AND NUTRITION, LLC, DBA ENTERAL CONFECTIONS, CHESTERFIELD, MO. SN 85-072,394. PUB. 11-23-2010, FILED 6-26-2010.



NO CLAIM IS MADE TO THE EXCLUSIVE RIGHT TO USE "BABY FLAKES", APART FROM THE MARK AS SHOWN.

THE MARK CONSISTS OF A HAND DRAWN PICTURE OF A SIMPLE BABY FACE SURROUNDED BY A CIRCLE OF UNEVEN LINE DIAMETER, WHICH IS THEN SURROUNDED BY DOTS ARRANGED IN A CIRCULAR FORM, ALL OF WHICH IS LOCATED ABOVE THE STYLIZED WORDING "BABYFLAKES".

FOR CHOCOLATE AND CHOCOLATES (U.S. CL. 46). FIRST USE 5-12-2011; IN COMMERCE 6-10-2011.

CLASS 30—(Continued).

4,017,035. STARBUCKS CORPORATION, DBA STARBUCKS COFFEE COMPANY, SEATTLE, WA. SN 85-099,609. PUB. 2-8-2011, FILED 8-4-2010.

CLASS 30—(Continued).

4,017,052. VALUE QUEST FOODS, ST. CLAIR SHORES, MI. SN 85-104,417. PUB. 1-11-2011, FILED 8-10-2010.

Big Show

STARBUCKS RESERVE

THE MARK CONSISTS OF STANDARD CHARACTERS WITHOUT CLAIM TO ANY PARTICULAR FONT, STYLE, SIZE, OR COLOR.

OWNER OF U.S. REG. NOS. 1,452,359, 3,298,944, AND OTHERS.

FOR GROUND AND WHOLE BEAN COFFEE; COFFEE BEVERAGES; BEVERAGES MADE WITH A BASE OF COFFEE; READY-TO-DRINK COFFEE (U.S. CL. 46). FIRST USE 8-3-2010; IN COMMERCE 8-3-2010.

THE MARK CONSISTS OF STANDARD CHARACTERS WITHOUT CLAIM TO ANY PARTICULAR FONT, STYLE, SIZE, OR COLOR.

FOR CANDY; CANDY BARS; CHOCOLATE; CHOCOLATE AND CHOCOLATES; CHOCOLATE BARS; CHOCOLATE CANDIES; CHOCOLATES AND CHOCOLATE BASED READY TO EAT CANDIES AND SNACKS; CONFECTIONERIES, NAMELY, SNACK FOODS, NAMELY, CHOCOLATE; FILLED CHOCOLATE; SNACK FOODS, NAMELY, CHOCOLATE-BASED SNACK FOODS (U.S. CL. 46).

FIRST USE 10-1-2010; IN COMMERCE 12-10-2010.

4,017,123. PRINCE, MARY, DBA ROOKIES COOKIES, HOUSTON, TX. SN 85-130,813. PUB. 4-12-2011, FILED 9-16-2010.

4,017,041. STARBUCKS CORPORATION, DBA STARBUCKS COFFEE COMPANY, SEATTLE, WA. SN 85-100,943. PUB. 2-8-2011, FILED 8-5-2010.



THE MARK CONSISTS OF A CAPITAL "R" CENTERED BELOW A FIVE POINTED STAR SEPARATED BY A HORIZONTAL LINE.

FOR GROUND AND WHOLE BEAN COFFEE; COFFEE BEVERAGES; BEVERAGES MADE WITH A BASE OF COFFEE; READY-TO-DRINK COFFEE (U.S. CL. 46). FIRST USE 8-3-2010; IN COMMERCE 8-3-2010.



NO CLAIM IS MADE TO THE EXCLUSIVE RIGHT TO USE "COOKIES", APART FROM THE MARK AS SHOWN.

THE COLOR(S) RED, BLACK, ORANGE, WHITE, LIGHT BROWN, BLUE AND LIGHT BLUE IS/ARE CLAIMED AS A FEATURE OF THE MARK.

THE MARK CONSISTS OF INSIDE OF A LARGE CIRCLE THE WORD "ROOKIES" IN RED WITH BLACK OUTLINING ARCHED ACROSS THE TOP THE WORD "COOKIES" AT THE BOTTOM IN RED WITH BLACK OUTLINING, CONTAINED IN A SMALLER CIRCLE INSIDE THE LARGE CIRCLE A YOUNG LIGHT BROWN MALE BASKETBALL PLAYER WITH BROWN EYES HOLDING AN ORANGE BASKETBALL UNDER HIS LEFT ARM THAT HAS A WHITE WRISTBAND AND ON HIS HEAD HE WEARS A WHITE HEADBAND. HE IS ALSO WEARING A RED SHIRT UNDERNEATH A BLACK JERSEY OUTLINED WITH WHITE CONSISTING OF A NUMBER "3" IN WHITE AND HAS ON BLACK SHORTS. THE BASKETBALL PLAYER IS

CLASS 30—(Continued).

HOLDING UP HIS RIGHT INDEX FINGER SHOWING THE NUMBER "1". BETWEEN THE TWO CIRCLES ON THE LEFT SIDE ARE 5 STARS IN BLACK AND WHITE THAT GET SMALLER IN SIZE WITH THE LARGEST STAR ON TOP AND THE SMALLEST STAR ON THE BOTTOM. BETWEEN THE CIRCLES ON THE RIGHT SIDE ARE 5 STARS IN BLACK AND WHITE THAT GET SMALLER IN SIZE WITH THE LARGEST STAR ON TOP AND THE SMALLEST STAR ON THE BOTTOM. THE BACKGROUND OF THE SMALLER CIRCLE IS BLUE.

FOR COOKIES (U.S. CL. 46).
FIRST USE 0-0-2010; IN COMMERCE 0-0-2010.

4,017,142. ARNOLD PALMER ENTERPRISES, INC., CLEVELAND, OH. SN 85-141,210. PUB. 3-15-2011, FILED 9-29-2010.



OWNER OF U.S. REG. NOS. 2,147,775, 3,723,321, AND OTHERS.

THE COLOR GRAY IS FOR SHADING PURPOSES ONLY. THE NAME "ARNOLD PALMER" IDENTIFIES A LIVING INDIVIDUAL WHOSE CONSENT IS OF RECORD.

THE MARK CONSISTS OF THE SIGNATURE "ARNOLD PALMER" WITH AN UMBRELLA DESIGN.

FOR FROZEN CONFECTIONS, NAMELY, FREEZER BARS (U.S. CL. 46).

FIRST USE 1-1-2011; IN COMMERCE 1-1-2011.

4,017,188. MEXICO FOODS, LLC, HOUSTON, TX. SN 85-167,339. PUB. 4-12-2011, FILED 11-2-2010.



THE COLOR(S) BROWN, GOLD, AND YELLOW IS/ARE CLAIMED AS A FEATURE OF THE MARK.

THE MARK CONSISTS OF THREE ALMOST VERTICALLY PLACED TAMALES IN YELLOW AND GOLD OUTLINED IN BROWN, WITH GOLD AND BROWN BOW TIES AROUND THE MIDDLE TAMALES AND THE TAMALES FURTHEST TO THE LEFT. THE VERTICALLY PLACED TAMALES ARE ADORNED BY A BROWN BANNER OUTLINED IN GOLD CONTAINING THE WORD "GLORIA" IN YELLOW WHICH IS PLACED ACROSS THE BOTTOM HALF OF THE TAMALES, WITH THE WORD "DONA" IN BROWN ABOVE THE BANNER IN A RECTANGULAR SHAPED YELLOW BOX OUTLINED IN BROWN.

THE ENGLISH TRANSLATION OF THE WORD "DONA" IN THE MARK IS "MS." OR "LADY".

FOR TAMALES (U.S. CL. 46).
FIRST USE 1-1-2011; IN COMMERCE 1-1-2011.

CLASS 30—(Continued).

4,017,200. BARBARA'S CONFECTIONS LLC, MADISON, NJ. SN 85-171,619. PUB. 3-29-2011, FILED 11-8-2010.

BARBARA'S BUTTER CRUNCH

THE MARK CONSISTS OF STANDARD CHARACTERS WITHOUT CLAIM TO ANY PARTICULAR FONT, STYLE, SIZE, OR COLOR.

NO CLAIM IS MADE TO THE EXCLUSIVE RIGHT TO USE "BUTTER CRUNCH", APART FROM THE MARK AS SHOWN.

FOR CANDY (U.S. CL. 46).
FIRST USE 1-1-2011; IN COMMERCE 1-1-2011.

4,017,203. PK'S CHOCOLATES INC., NEWHALL, CA. SN 85-172,093. PUB. 4-26-2011, FILED 11-9-2010.

PK'S CHOCOLATES

THE MARK CONSISTS OF STANDARD CHARACTERS WITHOUT CLAIM TO ANY PARTICULAR FONT, STYLE, SIZE, OR COLOR.

NO CLAIM IS MADE TO THE EXCLUSIVE RIGHT TO USE "CHOCOLATES", APART FROM THE MARK AS SHOWN.

FOR STAPLE FOODS, NAMELY, CHOCOLATE CANDY (U.S. CL. 46).
FIRST USE 9-1-2010; IN COMMERCE 4-1-2011.

4,017,269. UPFRONT FOODS, LLC, BOCA RATON, FL. SN 85-975,477. PUB. 8-3-2010, FILED 5-5-2010.

UPFRONT FOODS

THE MARK CONSISTS OF STANDARD CHARACTERS WITHOUT CLAIM TO ANY PARTICULAR FONT, STYLE, SIZE, OR COLOR.

NO CLAIM IS MADE TO THE EXCLUSIVE RIGHT TO USE "FOODS", APART FROM THE MARK AS SHOWN.

FOR GRANOLA CEREALS; BREAKFAST CEREALS; GRANOLA SNACKS (U.S. CL. 46).

FIRST USE 11-17-2010; IN COMMERCE 12-3-2010.

CLASS 31—NATURAL AGRICULTURAL PRODUCTS

CLASS 31—(Continued).

4,016,188. BLADERUNNER FARMS, INC., POTEET, TX. SN 77-198,183. PUB. 11-16-2010, FILED 6-5-2007.

ZEON

THE MARK CONSISTS OF STANDARD CHARACTERS WITHOUT CLAIM TO ANY PARTICULAR FONT, STYLE, SIZE, OR COLOR.

THE WORD "ZEON" HAS NO MEANING IN A FOREIGN LANGUAGE.

FOR SOD (U.S. CLS. 1 AND 46).

FIRST USE 4-0-1998; IN COMMERCE 4-0-1998.

4,016,806. INTERNATIONAL FRUIT GENETICS, LLC, BAKERSFIELD, CA. SN 85-037,601. PUB. 10-12-2010, FILED 5-13-2010.

Sweet Jubilee

THE MARK CONSISTS OF STANDARD CHARACTERS WITHOUT CLAIM TO ANY PARTICULAR FONT, STYLE, SIZE, OR COLOR.

OWNER OF U.S. REG. NOS. 3,636,713, 3,772,089, AND OTHERS.

FOR LIVE PLANTS, NAMELY, GRAPE VINES (U.S. CLS. 1 AND 46).

FIRST USE 7-26-2010; IN COMMERCE 7-26-2010.

4,016,815. PREFERRED COMMERCE, INC., WEST PALM BEACH, FL. SN 85-040,660. PUB. 10-19-2010, FILED 5-17-2010.

GROWUMS

THE MARK CONSISTS OF STANDARD CHARACTERS WITHOUT CLAIM TO ANY PARTICULAR FONT, STYLE, SIZE, OR COLOR.

FOR PLANT SEEDS; FRUIT AND VEGETABLE SEEDS; GARDENING KITS FOR INDOOR AND OUTDOOR PLANTING COMPOSED OF FRUIT AND VEGETABLE SEEDS, PEAT POTS, AND PEAT PELLETS (U.S. CLS. 1 AND 46).

FIRST USE 1-4-2010; IN COMMERCE 1-4-2010.

CLASS 31—(Continued).

4,017,132. THE PET HYDRATION PEOPLE, LLC, CHICAGO, IL. SN 85-135,234. PUB. 3-8-2011, FILED 9-22-2010.

Licks

THE MARK CONSISTS OF STANDARD CHARACTERS WITHOUT CLAIM TO ANY PARTICULAR FONT, STYLE, SIZE, OR COLOR.

FOR PET BEVERAGES (U.S. CLS. 1 AND 46).

FIRST USE 8-25-2010; IN COMMERCE 12-17-2010.

CLASS 32—LIGHT BEVERAGES

4,016,153. MISSISSIPPI STATE UNIVERSITY, MISSISSIPPI STATE, MS. SN 76-697,425. PUB. 9-22-2009, FILED 5-18-2009.



THE MARK CONSISTS OF THE WORD "JUVA" IN STYLIZED FORM BELOW AN ELLIPTICAL, STYLIZED SWIRL.

FOR CARBONATED AND NON-CARBONATED FRUIT FLAVORED DRINKS; FRUIT JUICES; SMOOTHIES; FRUIT SMOOTHIES; FRUIT-BASED HEALTHY BEVERAGES, NAMELY, FRUIT BEVERAGES AND FROZEN FRUIT-BASED BEVERAGES, EXCLUDING WEIGHT-CONTROL DRINKS, BEVERAGES AND SUPPLEMENTS (U.S. CLS. 45, 46 AND 48).

FIRST USE 11-30-2010; IN COMMERCE 11-30-2010.

CLASS 32—(Continued).

4,016,420. DS WATERS OF AMERICA, INC., ATLANTA, GA.
SN 77-856,026. PUB. 5-25-2010, FILED 10-23-2009.

REWARD

THE MARK CONSISTS OF STANDARD CHARACTERS WITHOUT CLAIM TO ANY PARTICULAR FONT, STYLE, SIZE, OR COLOR.

FOR POWDERS USED IN THE PREPARATION OF NON-ALCOHOLIC FRUIT FLAVORED BEVERAGES (U.S. CLS. 45, 46 AND 48).

FIRST USE 3-1-2011; IN COMMERCE 3-1-2011.

4,016,854. ELHALWANI, WAEL, ANAHEIM, CA. SN 85-051,424. PUB. 11-2-2010, FILED 6-1-2010.

TOPAZ

THE MARK CONSISTS OF STANDARD CHARACTERS WITHOUT CLAIM TO ANY PARTICULAR FONT, STYLE, SIZE, OR COLOR.

FOR DRINKING WATER, SPARKLING WATER, FLAVORED WATERS (U.S. CLS. 45, 46 AND 48).

FIRST USE 9-11-2010; IN COMMERCE 9-11-2010.

4,017,066. ANHEUSER BUSCH, INCORPORATED, ST. LOUIS, MO. SN 85-108,016. PUB. 2-1-2011, FILED 8-16-2010.

GREAT TIMES ARE WAITING

THE MARK CONSISTS OF STANDARD CHARACTERS WITHOUT CLAIM TO ANY PARTICULAR FONT, STYLE, SIZE, OR COLOR.

FOR BEER (U.S. CLS. 45, 46 AND 48).

FIRST USE 9-24-2010; IN COMMERCE 9-24-2010.

CLASS 32—(Continued).

4,017,108. BERGHAUSEN CORPORATION, CINCINNATI, OH. SN 85-124,902. PUB. 2-22-2011, FILED 9-8-2010.

HYDRATE YOUR NIGHT

THE MARK CONSISTS OF STANDARD CHARACTERS WITHOUT CLAIM TO ANY PARTICULAR FONT, STYLE, SIZE, OR COLOR.

FOR NON-ALCOHOLIC BEVERAGES IN THE NATURE OF COCKTAIL MIXES; NON-ALCOHOLIC BEVERAGES IN THE NATURE OF CARBONATED BEVERAGES (U.S. CLS. 45, 46 AND 48).

FIRST USE 3-11-2011; IN COMMERCE 3-11-2011.

4,017,190. ANHEUSER-BUSCH, INCORPORATED, ST. LOUIS, MO. SN 85-167,880. PUB. 3-8-2011, FILED 11-3-2010.

**ON AMERICA'S BIRTHDAY,
DRINK AMERICA'S BEER**

THE MARK CONSISTS OF STANDARD CHARACTERS WITHOUT CLAIM TO ANY PARTICULAR FONT, STYLE, SIZE, OR COLOR.

FOR BEER (U.S. CLS. 45, 46 AND 48).

FIRST USE 5-31-2011; IN COMMERCE 5-31-2011.

4,017,192. STOKELY-VAN CAMP, INC., CHICAGO, IL. SN 85-168,933. PUB. 3-8-2011, FILED 11-4-2010.

GATORADE 03 RECOVER

THE MARK CONSISTS OF STANDARD CHARACTERS WITHOUT CLAIM TO ANY PARTICULAR FONT, STYLE, SIZE, OR COLOR.

OWNER OF U.S. REG. NOS. 848,245, 3,801,121, AND OTHERS.

NO CLAIM IS MADE TO THE EXCLUSIVE RIGHT TO USE "03", APART FROM THE MARK AS SHOWN.

FOR NON-ALCOHOLIC FRUIT FLAVORED BEVERAGES ENHANCED WITH PROTEINS; NON-ALCOHOLIC FRUIT FLAVORED BEVERAGES (U.S. CLS. 45, 46 AND 48).

FIRST USE 4-30-2011; IN COMMERCE 4-30-2011.

CLASS 32—(Continued).

4,017,250. WINERY EXCHANGE, INC., NOVATO, CA. SN 85-229,372. PUB. 5-3-2011, FILED 1-29-2011.

DOUBLE TAKE BREWING CO.

THE MARK CONSISTS OF STANDARD CHARACTERS WITHOUT CLAIM TO ANY PARTICULAR FONT, STYLE, SIZE, OR COLOR.

NO CLAIM IS MADE TO THE EXCLUSIVE RIGHT TO USE "BREWING CO.", APART FROM THE MARK AS SHOWN.

FOR BEER (U.S. CLS. 45, 46 AND 48).
FIRST USE 5-0-2011; IN COMMERCE 5-0-2011.

CLASS 33—(Continued).

4,016,364. THE WINE GROUP LLC, TRACY, CA. SN 77-771,483. PUB. 11-3-2009, FILED 6-30-2009.

OLDE SAVANNAH

THE MARK CONSISTS OF STANDARD CHARACTERS WITHOUT CLAIM TO ANY PARTICULAR FONT, STYLE, SIZE, OR COLOR.

FOR WINE (U.S. CLS. 47 AND 49).
FIRST USE 12-14-2009; IN COMMERCE 12-14-2009.

CLASS 33—WINES AND SPIRITS

4,016,238. CALEB FOSTER WINES, L.L.C. WALLA WALLA, WA. SN 77-359,305. PUB. 5-20-2008, FILED 12-26-2007.

ROCKGARDEN

THE MARK CONSISTS OF STANDARD CHARACTERS WITHOUT CLAIM TO ANY PARTICULAR FONT, STYLE, SIZE, OR COLOR.

FOR WINES (U.S. CLS. 47 AND 49).
FIRST USE 3-17-2011; IN COMMERCE 3-17-2011.

4,016,337. V & C, LLC, GOLDENDALE, WA. SN 77-744,886. PUB. 4-27-2010, FILED 5-26-2009.

MARYHILL VINTNERS

THE MARK CONSISTS OF STANDARD CHARACTERS WITHOUT CLAIM TO ANY PARTICULAR FONT, STYLE, SIZE, OR COLOR.

OWNER OF U.S. REG. NOS. 2,681,738 AND 2,976,624.
NO CLAIM IS MADE TO THE EXCLUSIVE RIGHT TO USE "VINTNERS", APART FROM THE MARK AS SHOWN.
FOR WINE (U.S. CLS. 47 AND 49).
FIRST USE 4-30-2011; IN COMMERCE 4-30-2011.

4,016,371. BALCONES DISTILLING LLC, DBA BALCONES DISTILLING, WACO, TX. SN 77-781,465. PUB. 11-17-2009, FILED 7-15-2009.

BABY BLUE

THE MARK CONSISTS OF STANDARD CHARACTERS WITHOUT CLAIM TO ANY PARTICULAR FONT, STYLE, SIZE, OR COLOR.

FOR DISTILLED SPIRITS; SPIRITS; SPIRITS AND LIQUEURS (U.S. CLS. 47 AND 49).
FIRST USE 9-1-2009; IN COMMERCE 9-1-2009.

4,016,477. O'NEILL BEVERAGE CO., LTD., PARLIER, CA. SN 77-889,010. PUB. 5-11-2010, FILED 12-8-2009.

GRAVELLY FORD

THE MARK CONSISTS OF STANDARD CHARACTERS WITHOUT CLAIM TO ANY PARTICULAR FONT, STYLE, SIZE, OR COLOR.

FOR WINE (U.S. CLS. 47 AND 49).
FIRST USE 4-13-2011; IN COMMERCE 4-13-2011.

CLASS 33—(Continued).

4,016,482. OH IL ENTERPRISE CO., LTD., SEOUL, REPUBLIC OF KOREA. SN 77-890,272. PUB. 10-26-2010, FILED 12-10-2009.

WOLMAE

THE MARK CONSISTS OF STANDARD CHARACTERS WITHOUT CLAIM TO ANY PARTICULAR FONT, STYLE, SIZE, OR COLOR.
FOR TAG-JU (UNSTRAINED RICE WINE) (U.S. CLS. 47 AND 49).
FIRST USE 5-0-2009; IN COMMERCE 5-0-2009.

4,016,483. OH IL ENTERPRISE CO., LTD., SEOUL, REPUBLIC OF KOREA. SN 77-890,295. PUB. 10-26-2010, FILED 12-10-2009.

월매

THE MARK CONSISTS OF KOREAN CHARACTERS. THE NON-LATIN CHARACTERS IN THE MARK TRANSLITERATE TO "WOLMAE" AND THIS HAS NO MEANING IN A FOREIGN LANGUAGE.
FOR TAG-JU (UNSTRAINED RICE WINE) (U.S. CLS. 47 AND 49).
FIRST USE 5-0-2010; IN COMMERCE 5-0-2010.

4,016,526. OFFENBACHER, DOUG, SANTA ROSA, CA. SN 77-904,613. PUB. 5-18-2010, FILED 1-4-2010.

SLONOMA

THE MARK CONSISTS OF STANDARD CHARACTERS WITHOUT CLAIM TO ANY PARTICULAR FONT, STYLE, SIZE, OR COLOR.
FOR ALCOHOLIC BEVERAGES EXCEPT BEERS (U.S. CLS. 47 AND 49).
FIRST USE 7-12-2011; IN COMMERCE 7-12-2011.

CLASS 33—(Continued).

4,016,552. O'NEILL BEVERAGE CO., LTD., PARLIER, CA. SN 77-918,529. PUB. 11-23-2010, FILED 1-22-2010.

FLAT ROCK

THE MARK CONSISTS OF STANDARD CHARACTERS WITHOUT CLAIM TO ANY PARTICULAR FONT, STYLE, SIZE, OR COLOR.
FOR WINE (U.S. CLS. 47 AND 49).
FIRST USE 6-30-2010; IN COMMERCE 6-30-2010.

4,016,553. O'NEILL BEVERAGE CO., LTD., PARLIER, CA. SN 77-918,534. PUB. 5-4-2010, FILED 1-22-2010.

GROUNDSWELL

THE MARK CONSISTS OF STANDARD CHARACTERS WITHOUT CLAIM TO ANY PARTICULAR FONT, STYLE, SIZE, OR COLOR.
FOR WINE (U.S. CLS. 47 AND 49).
FIRST USE 4-6-2011; IN COMMERCE 4-6-2011.

4,016,666. VILLA MARIA ESTATE LIMITED, MANGERE AUCKLAND, NEW ZEALAND. SN 77-969,430. PUB. 1-4-2011, FILED 3-26-2010.

esk valley.



OWNER OF U.S. REG. NO. 2,816,198.
NO CLAIM IS MADE TO THE EXCLUSIVE RIGHT TO USE "ESK VALLEY", APART FROM THE MARK AS SHOWN.

CLASS 33—(Continued).

THE MARK CONSISTS OF THE LITERAL PORTION "ESK VALLEY" IN STYLIZED CURSIVE WRITING IN A STACKED FORMATION ABOVE A DEPICTION OF A MISSION STYLE BUILDING ENCLOSED IN A CIRCULAR FIELD.

FOR WINE (U.S. CLS. 47 AND 49).
FIRST USE 7-1-2011; IN COMMERCE 7-1-2011.

CLASS 33—(Continued).

4,016,847. ADAMS WINERY, LLC, HEALDSBURG, CA. SN 85-049,337. PUB. 10-19-2010, FILED 5-27-2010.

4,016,677. WASHINGTON WINE AND BEVERAGE COMPANY, WOODINVILLE, WA. SN 77-982,095. PUB. 10-26-2010, FILED 12-1-2009.

BROWN BOX WINE

THE MARK CONSISTS OF STANDARD CHARACTERS WITHOUT CLAIM TO ANY PARTICULAR FONT, STYLE, SIZE, OR COLOR.

NO CLAIM IS MADE TO THE EXCLUSIVE RIGHT TO USE "BOX WINE", APART FROM THE MARK AS SHOWN.
FOR WINE (U.S. CLS. 47 AND 49).
FIRST USE 7-26-2010; IN COMMERCE 7-27-2010.

TEN ACRE

THE MARK CONSISTS OF STANDARD CHARACTERS WITHOUT CLAIM TO ANY PARTICULAR FONT, STYLE, SIZE, OR COLOR.

FOR WINE (U.S. CLS. 47 AND 49).
FIRST USE 10-10-2010; IN COMMERCE 10-10-2010.

4,016,736. PISCO PORTON, LLC, HOUSTON, TX. SN 85-006,585. PUB. 8-31-2010, FILED 4-5-2010.

PISCO PORTON

THE MARK CONSISTS OF STANDARD CHARACTERS WITHOUT CLAIM TO ANY PARTICULAR FONT, STYLE, SIZE, OR COLOR.

NO CLAIM IS MADE TO THE EXCLUSIVE RIGHT TO USE "PISCO", APART FROM THE MARK AS SHOWN.

THE ENGLISH TRANSLATION OF "PORTON" IN THE MARK IS "GATE".

FOR DISTILLED SPIRITS; BRANDY; PISCO; ALCOHOLIC COCKTAIL MIXES (U.S. CLS. 47 AND 49).
FIRST USE 3-15-2011; IN COMMERCE 3-15-2011.

4,016,867. DELTA GREEN, MADERA, CA. SN 85-054,861. PUB. 11-9-2010, FILED 6-4-2010.



NO CLAIM IS MADE TO THE EXCLUSIVE RIGHT TO USE "POMEGRANATES", APART FROM THE MARK AS SHOWN.

THE MARK CONSISTS OF A STYLIZED DRAWING OF A TREE WITH TWO POMEGRANATES IN THE TREE. ALL ABOVE THE WORDS "TWIN POMEGRANATES". COLOR IS NOT CLAIMED.

FOR WINES (U.S. CLS. 47 AND 49).
FIRST USE 5-4-2010; IN COMMERCE 5-4-2010.

CLASS 33—(Continued).

4,016,971. DIAGEO NORTH AMERICA, INC., NORWALK, CT. SN 85-079,249. PUB. 5-3-2011, FILED 7-7-2010.



NO CLAIM IS MADE TO THE EXCLUSIVE RIGHT TO USE "QREAM", APART FROM THE MARK AS SHOWN.

THE MARK CONSISTS OF A STYLIZED LETTER "Q" TOPPED WITH A CROWN OVER THE WORD "QREAM". THE TAIL OF THE STYLIZED "Q" REACHES DOWNWARD TO CROSS THE "A" IN THE WORD "QREAM".

FOR ALCOHOLIC BEVERAGES EXCEPT BEERS (U.S. CLS. 47 AND 49).

FIRST USE 6-30-2011; IN COMMERCE 6-30-2011.

4,017,131. MISSISSIPPI RIVER DISTILLING COMPANY, LECLAIRE, IA. SN 85-134,227. PUB. 3-8-2011, FILED 9-21-2010.

RIVER BARON

THE MARK CONSISTS OF STANDARD CHARACTERS WITHOUT CLAIM TO ANY PARTICULAR FONT, STYLE, SIZE, OR COLOR.

FOR DISTILLED SPIRITS; VODKA (U.S. CLS. 47 AND 49).

FIRST USE 12-17-2010; IN COMMERCE 12-17-2010.

CLASS 33—(Continued).

4,017,219. H.D.D. LLC, DBA TRUETT HURST WINERY, HEALDSBURG, CA. SN 85-183,331. PUB. 3-15-2011, FILED 11-23-2010.

THE COUNTY FAIR

THE MARK CONSISTS OF STANDARD CHARACTERS WITHOUT CLAIM TO ANY PARTICULAR FONT, STYLE, SIZE, OR COLOR.

FOR ALCOHOLIC BEVERAGES EXCEPT BEERS (U.S. CLS. 47 AND 49).

FIRST USE 4-22-2011; IN COMMERCE 4-22-2011.

4,017,236. CAPE CLASSICS BRANDS LLC, WEST PALM BEACH, FL. SN 85-198,537. PUB. 3-15-2011, FILED 12-15-2010.

SUGARBIRD

THE MARK CONSISTS OF STANDARD CHARACTERS WITHOUT CLAIM TO ANY PARTICULAR FONT, STYLE, SIZE, OR COLOR.

FOR WINES (U.S. CLS. 47 AND 49).

FIRST USE 6-17-2011; IN COMMERCE 6-17-2011.

4,017,240. BACARDI & COMPANY LIMITED, VADUZ FL-9490, LIECHTENSTEIN. SN 85-203,149. PUB. 4-26-2011, FILED 12-21-2010.

**BACARDI
ARCTIC
GRAPE**



OWNER OF U.S. REG. NOS. 310,654, 331,459, AND OTHERS.

NO CLAIM IS MADE TO THE EXCLUSIVE RIGHT TO USE "GRAPE", APART FROM THE MARK AS SHOWN.

THE COLOR(S) BLACK, GOLD, BLUE, LIGHT BLUE, SILVER, GREEN AND LIGHT GREEN IS/ARE CLAIMED AS A FEATURE OF THE MARK.

CLASS 33—(Continued).

THE MARK CONSISTS OF STACKED WORDS "BACARDI", "ARCTIC", AND "GRAPE", OVER A SERIES OF SEVEN JAGGED SHAPES, THE BOTTOMMOST SHAPE ACCEPTING FOUR CHEVRON SHAPES, AND THE BOTTOMMOST SHAPE EMBRACING A BOW SHAPE, THE BOW SHAPE EMBRACING A HALF-CIRCLE SHAPE. THE COLOR BLACK APPEARS ON THE LETTERS OF "BACARDI", "ARCTIC", AND "GRAPE", TRIMMED IN THE COLOR GOLD; THE COLORS LIGHT BLUE AND BLUE APPEAR ON THE SEVEN JAGGED SHAPES, TRIMMED IN THE COLOR SILVER; THE COLORS LIGHT GREEN AND GREEN APPEAR ON THE FOUR CHEVRON SHAPES AND THE HALF-CIRCLE SHAPE; THE COLOR SILVER APPEARS ON THE BOW SHAPE. THE COLOR WHITE REPRESENTS BACKGROUND AND IS NOT CLAIMED AS A FEATURE OF THE MARK.

FOR DISTILLED SPIRITS, NAMELY, RUM AND RUM-BASED BEVERAGES; PREPARED ALCOHOLIC COCKTAILS, NAMELY, COCKTAILS FLAVORED WITH RUM (U.S. CLS. 47 AND 49).

FIRST USE 4-0-2011; IN COMMERCE 4-0-2011.

4,017,259. THE WINE GROUP LLC, TRACY, CA. SN 85-975,416. PUB. 9-21-2010, FILED 5-6-2010.

HAYDEN-HARLOW

THE MARK CONSISTS OF STANDARD CHARACTERS WITHOUT CLAIM TO ANY PARTICULAR FONT, STYLE, SIZE, OR COLOR.

FOR WINE (U.S. CLS. 47 AND 49).

FIRST USE 6-24-2011; IN COMMERCE 6-24-2011.

CLASS 34—SMOKERS' ARTICLES

4,016,306. STONES INC., TALLAHASSEE, FL. SN 77-673,040. PUB. 9-29-2009, FILED 2-18-2009.



THE MARK CONSISTS OF A STYLIZED FORM OF THE LETTER "S". THE "S" IS REPRESENTED IN TWO HALVES, SEPARATED SLIGHTLY. THE LETTER IS DIVIDED VERTICALLY WITH A LEFT HALF AND RIGHT HALF.

FOR TOBACCO FILTERS; TOBACCO PIPES (U.S. CLS. 2, 8, 9 AND 17).

FIRST USE 1-1-2009; IN COMMERCE 1-1-2009.

CLASS 34—(Continued).

4,016,348. HEARTHMARK, LLC, DALEVILLE, IN. SN 77-752,890. PUB. 10-20-2009, FILED 6-5-2009.



THE MARK CONSISTS OF A CIRCLE DIVIDED IN QUADRANTS BY CROSSHAIRS WITH AN ECLIPSE CENTERED OVER THE CROSSHAIRS TO REPRESENT A GLOBE OF THE EARTH POSITIONED ABOVE A HAND WITH THE LITERAL ELEMENTS OF "EARTH IN MIND SOLUTIONS" POSITIONED TO THE RIGHT OF THE GLOBE AND HAND.

FOR MATCHES (U.S. CLS. 2, 8, 9 AND 17).

FIRST USE 3-31-2011; IN COMMERCE 3-31-2011.

4,016,368. NICARAGUA TOBACCO IMPORTS, INC., DBA CUBAN CRAFTERS, MIAMI, FL. SN 77-774,351. PUB. 11-24-2009, FILED 7-5-2009.

EDEN

THE MARK CONSISTS OF STANDARD CHARACTERS WITHOUT CLAIM TO ANY PARTICULAR FONT, STYLE, SIZE, OR COLOR.

FOR CIGAR AND CIGARETTE BOXES; CIGAR AND CIGARETTE BOXES NOT OF PRECIOUS METAL; CIGAR BOXES; CIGAR BOXES NOT OF PRECIOUS METAL; CIGARS; TOBACCO, CIGARS AND CIGARETTES (U.S. CLS. 2, 8, 9 AND 17).

FIRST USE 11-12-2010; IN COMMERCE 2-21-2011.

4,017,258. LAVA MARKETING GROUP, INC., AKA LAVA, BIRMINGHAM, MI. SN 85-975,407. PUB. 11-23-2010, FILED 6-18-2010.

LAVA

THE MARK CONSISTS OF STANDARD CHARACTERS WITHOUT CLAIM TO ANY PARTICULAR FONT, STYLE, SIZE, OR COLOR.

FOR ELECTRIC CIGARETTES; ELECTRONIC CIGARETTES (U.S. CLS. 2, 8, 9 AND 17).

FIRST USE 1-31-2011; IN COMMERCE 1-31-2011.

CLASS 34—(Continued).

SERVICE MARKS

CLASS 35—ADVERTISING AND BUSINESS

4,016,160. TAIWAN EXTERNAL TRADE DEVELOPMENT COUNCIL, TAIPEI, TAIWAN. SN 76-701,188. PUB. 11-23-2010, FILED 1-12-2010.

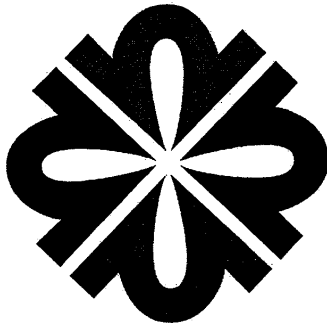

THE MARK CONSISTS OF A FOUR PETAL FLOWER DESIGN CONSISTING OF THICK LINES. BETWEEN EACH PETAL AND STEMMING FROM THE CENTER OF THE FLOWER DESIGN IS A LINE, FORMING THE SHAPE OF AN X.

FOR PROMOTING THE GOODS AND SERVICES MADE OR RENDERED IN TAIWAN BY OTHERS, BY DISSEMINATION OF ADVERTISING MATTER, BY ARRANGING AND CONDUCTING EXHIBITIONS OF SUCH GOODS AND SERVICES, AND BY THE DISTRIBUTION OF T-SHIRTS, SHOPPING BAGS AND OTHER PROMOTIONAL GIFTS (U.S. CLS. 100, 101 AND 102).
FIRST USE 1-1-2006; IN COMMERCE 1-1-2006.

4,016,167. PAXTON, GRAHAM, EVANSVILLE, IN. SN 77-069,115. PUB. 5-3-2011, FILED 12-21-2006.

Swift Athletics

THE MARK CONSISTS OF STANDARD CHARACTERS WITHOUT CLAIM TO ANY PARTICULAR FONT, STYLE, SIZE, OR COLOR.

NO CLAIM IS MADE TO THE EXCLUSIVE RIGHT TO USE "ATHLETICS", APART FROM THE MARK AS SHOWN.

FOR RETAIL STORES FEATURING RUNNING SHOES, APPAREL, AND RELATED ACCESSORIES (U.S. CLS. 100, 101 AND 102).

FIRST USE 3-2-2007; IN COMMERCE 3-2-2007.

CLASS 35—(Continued).

4,016,168. PAXTON, GRAHAM, EVANSVILLE, IN. SN 77-069,502. PUB. 5-3-2011, FILED 12-21-2006.



NO CLAIM IS MADE TO THE EXCLUSIVE RIGHT TO USE "ATHLETICS", APART FROM THE MARK AS SHOWN. FOR RETAIL STORES FEATURING RUNNING SHOES, APPAREL, AND RELATED ACCESSORIES (U.S. CLS. 100, 101 AND 102).

FIRST USE 3-2-2007; IN COMMERCE 3-2-2007.

4,016,198. AIKEN LEGAL SEARCH, LLC, ATLANTA, GA. SN 77-270,478. PUB. 6-10-2008, FILED 9-3-2007.

Avid Attorney Search

THE MARK CONSISTS OF STANDARD CHARACTERS WITHOUT CLAIM TO ANY PARTICULAR FONT, STYLE, SIZE, OR COLOR.

NO CLAIM IS MADE TO THE EXCLUSIVE RIGHT TO USE "ATTORNEY SEARCH", APART FROM THE MARK AS SHOWN.

FOR LEGAL RECRUITING COMPANY THAT STAFFS/PLACES ATTORNEYS AT LAW FIRMS AND CORPORATIONS (U.S. CLS. 100, 101 AND 102).

FIRST USE 7-1-2011; IN COMMERCE 7-1-2011.

4,016,252. LEADERSHIP, EDUCATION AND DEVELOPMENT (LEAD), PHILADELPHIA, PA. SN 77-432,942. PUB. 9-29-2009, FILED 3-27-2008.

LEAD GLOBAL

THE MARK CONSISTS OF STANDARD CHARACTERS WITHOUT CLAIM TO ANY PARTICULAR FONT, STYLE, SIZE, OR COLOR.

NO CLAIM IS MADE TO THE EXCLUSIVE RIGHT TO USE "GLOBAL", APART FROM THE MARK AS SHOWN.

FOR ADMINISTRATION OF EDUCATIONAL PROGRAMS FOR MINORITY STUDENTS (U.S. CLS. 100, 101 AND 102).

FIRST USE 5-0-2009; IN COMMERCE 5-0-2009.

CLASS 35—(Continued).

4,016,261. PSS WORLD MEDICAL, INC., JACKSONVILLE, FL. SN 77-472,771. PUB. 10-26-2010, FILED 5-13-2008.

MOMENTUM REWARDS

THE MARK CONSISTS OF STANDARD CHARACTERS WITHOUT CLAIM TO ANY PARTICULAR FONT, STYLE, SIZE, OR COLOR.

NO CLAIM IS MADE TO THE EXCLUSIVE RIGHT TO USE "REWARDS", APART FROM THE MARK AS SHOWN.

FOR CUSTOMER LOYALTY SERVICES AND CUSTOMER CLUB SERVICES, FOR COMMERCIAL, PROMOTIONAL AND/OR ADVERTISING PURPOSES AND NOT IN THE FIELDS OF MOUNTAINEERING, HIKING, CLIMBING, AND APPAREL (U.S. CLS. 100, 101 AND 102).

FIRST USE 5-0-2008; IN COMMERCE 5-0-2008.

4,016,263. PSS WORLD MEDICAL, INC., JACKSONVILLE, FL. SN 77-473,010. PUB. 10-26-2010, FILED 5-13-2008.



NO CLAIM IS MADE TO THE EXCLUSIVE RIGHT TO USE "REWARDS", APART FROM THE MARK AS SHOWN.

THE MARK CONSISTS OF THE WORDS "MOMENTUM REWARDS" WITH A STYLIZED "M".

FOR CUSTOMER LOYALTY SERVICES AND CUSTOMER CLUB SERVICES, FOR COMMERCIAL, PROMOTIONAL AND/OR ADVERTISING PURPOSES AND NOT IN THE FIELDS OF MOUNTAINEERING, HIKING, CLIMBING, AND APPAREL (U.S. CLS. 100, 101 AND 102).

FIRST USE 5-0-2008; IN COMMERCE 5-0-2008.

4,016,278. EXPRESS, LLC, COLUMBUS, OH. SN 77-592,856. PUB. 3-17-2009, FILED 10-15-2008.

EXPRESS

THE MARK CONSISTS OF STANDARD CHARACTERS WITHOUT CLAIM TO ANY PARTICULAR FONT, STYLE, SIZE, OR COLOR.

CLASS 35—(Continued).

OWNER OF U.S. REG. NOS. 1,120,073, 3,222,813, AND OTHERS.

FOR RETAIL STORE SERVICES, MAIL ORDER CATALOG SERVICES, AND ON-LINE RETAIL STORE SERVICES ALL FEATURING CLOTHING, CLOTHING ACCESSORIES, FASHION ACCESSORIES, MEN'S ACCESSORIES, NAMELY, BAGS, SMALL LEATHER GOODS, JEWELRY, AND EYEWEAR, LINGERIE, UNDERGARMENTS, HOSIERY, PERSONAL CARE PRODUCTS, AND FOOTWEAR (U.S. CLS. 100, 101 AND 102). FIRST USE 10-15-1997; IN COMMERCE 10-15-1997.

4,016,281. CYBATROL, INC., LAS VEGAS, NV. SN 77-609,875. PUB. 3-31-2009, FILED 11-7-2008.

**I.V.A.S.
Interactive Visitor
Announcement System**

THE MARK CONSISTS OF STANDARD CHARACTERS WITHOUT CLAIM TO ANY PARTICULAR FONT, STYLE, SIZE, OR COLOR.

NO CLAIM IS MADE TO THE EXCLUSIVE RIGHT TO USE "INTERACTIVE VISITOR ANNOUNCEMENT SYSTEM", APART FROM THE MARK AS SHOWN.

FOR PROVIDING A COMPUTER DATABASE FEATURING APPOINTMENT SCHEDULING INFORMATION AND A DESCRIPTION OF EACH EXPECTED VISITOR, INCLUDING THE VISIT DATE AND TIME, THE NAME OF EACH VISITOR (U.S. CLS. 100, 101 AND 102).

FIRST USE 5-15-2011; IN COMMERCE 5-15-2011.

4,016,313. ROBERT K. HANEY, BOULDER, CO. AND JENNIFER M. HANEY, BOULDER, CO. SN 77-690,083. PUB. 7-14-2009, FILED 3-12-2009.

RAGdeli

THE MARK CONSISTS OF STANDARD CHARACTERS WITHOUT CLAIM TO ANY PARTICULAR FONT, STYLE, SIZE, OR COLOR.

FOR WHOLESALE AND RETAIL STORE SERVICES FEATURING CLOTHING AND HOME DECOR (U.S. CLS. 100, 101 AND 102).

FIRST USE 9-9-2009; IN COMMERCE 11-30-2009.

CLASS 35—(Continued).

4,016,314. LEELOGIC INC, MOBILE, AL. SN 77-693,139. PUB. 2-9-2010, FILED 3-17-2009.

LegalLogic

THE MARK CONSISTS OF STANDARD CHARACTERS WITHOUT CLAIM TO ANY PARTICULAR FONT, STYLE, SIZE, OR COLOR.

FOR COMPUTERIZED AND CENTRAL FILE MANAGEMENT AND BUSINESS FILE MANAGEMENT; COMPUTERIZED FILE MANAGEMENT (U.S. CLS. 100, 101 AND 102).

FIRST USE 10-31-2010; IN COMMERCE 10-31-2010.

4,016,328. CARTER, MARY BETH, VISALIA, CA. SN 77-730,987. PUB. 6-1-2010, FILED 5-6-2009.

p.s. i love you too.

THE MARK CONSISTS OF STANDARD CHARACTERS WITHOUT CLAIM TO ANY PARTICULAR FONT, STYLE, SIZE, OR COLOR.

FOR RETAIL GIFT SHOPS FEATURING CANDLES, CANDLES HOLDERS, PICTURE FRAMES, WALL MIRRORS, PILLOWS AND THROWS, DECORATIVE LIGHTS, ARTIFICIAL FLOWERS AND PLANTS AND ROCKS; RETAIL GIFT SHOPS FEATURING PICNIC BASKETS, GARDEN STACKS, BISTRO TABLES, LOUNGE CHAIRS AND PILLOW CUSHIONS, GRILLING TONGS AND GRILLING RACKS AND SKEWERS; RETAIL GIFT SHOPS FEATURING BATH SOAPS, LOTIONS, SEA SALT RUBS, AROMATIC BOTTLE DIFFUSERS, BEESWAX BODY BUTTER LOTIONS AND LIP BALM, BATHROOM CANISTER SETS AND GUEST TOWELS; RETAIL GIFT SHOPS FEATURING BOTTLE OPENERS, CORKSCREWS, DECORATIVE BOTTLE STOPPERS AND POURERS, COASTERS, FOIL CUTTERS, MARTINI SHAKERS, WINE CARAFES AND WINE AERATORS, WINE RACKS AND WINE BOTTLE BAGS, FLASKS; RETAIL GIFT SHOPS FEATURING COOKIES, CHOCOLATE, CANDIES, JELLIES, BAKING MIXES AND SOUP MIXES, MUSTARDS, OLIVE OILS AND VINEGARS, TAPENADES, SALSAS, BBQ SAUCES AND RUBS, SPICE BLENDS, PASTA AND PASTA SAUCE, POPCORN AND POPCORN SALTS, NATURAL PEANUTS, COCOA, TEA AND COFFEE BLENDS, TEA DIFFUSERS AND TEA POTS, WINE CRACKERS, AND BISCOTTI; RETAIL GIFT SHOPS FEATURING DOG AND CAT BOWLS, PET CANISTERS, AND PET TREATS (U.S. CLS. 100, 101 AND 102).

FIRST USE 11-13-2010; IN COMMERCE 11-13-2010.

CLASS 35—(Continued).

4,016,329. VILLAGE FOX, LAKELAND, TN. SN 77-731,478. PUB. 11-2-2010, FILED 5-7-2009.

HOT FLASH DIVA

THE MARK CONSISTS OF STANDARD CHARACTERS WITHOUT CLAIM TO ANY PARTICULAR FONT, STYLE, SIZE, OR COLOR.

FOR RETAIL STORE AND ON-LINE RETAIL STORE SERVICES FEATURING APPAREL, APRONS, ARTWORK, AUTOMOBILE SUN VISORS, BAGS, TOTE BAGS, BINDERS, BOOKS AND GIFTBOOKS, BUMPER STICKERS, BUSINESS CARDS, BUTTONS, CALENDARS, CARDS, GREETING CARDS, CLOCKS, COASTERS, COMIC BOOKS, CUTTING BOARDS, BEVERAGWARE, EMBROIDERY, FLYERS, GAMES, GAME BOARDS, HATS, HOME ACCENTS, INK PENS, PENCILS, INVITATIONS, CELLULAR AND MOBILE PHONE CASES, JOURNALS, KEEPSAKE BOXES, KEY CHAINS, LETTERHEAD, LICENSE PLATE FRAMES, MAGNETS, MAGAZINES, MOUSE PADS, MUGS, NOTE CARDS, ORNAMENTS, PET BOWLS, PET CLOTHING, PHOTO CARDS, PHOTO SCULPTURES, PILLOWS, PLACE MATS, PLAQUES, POSTAGE, POSTERS AND PRINTS, SHOES, SKATEBOARDS, FITTED PLASTIC FILMS KNOWN AS SKINS FOR COVERING AND PROTECTING ELECTRONIC APPARATUS, STATIONERY, STICKERS AND DECALS, SUN VISORS, T-SHIRTS, TIES, WATER BOTTLES (U.S. CLS. 100, 101 AND 102).

FIRST USE 10-1-2008; IN COMMERCE 10-1-2008.

4,016,333. GUITAR CENTER, INC., WESTLAKE VILLAGE, CA. SN 77-736,361. PUB. 10-20-2009, FILED 5-13-2009.

KEEP THE MUSIC ALIVE

THE MARK CONSISTS OF STANDARD CHARACTERS WITHOUT CLAIM TO ANY PARTICULAR FONT, STYLE, SIZE, OR COLOR.

NO CLAIM IS MADE TO THE EXCLUSIVE RIGHT TO USE "MUSIC", APART FROM THE MARK AS SHOWN.

FOR PUBLIC ADVOCACY TO PROMOTE AWARENESS OF MUSIC AND MUSIC EDUCATION IN SCHOOLS (U.S. CLS. 100, 101 AND 102).

FIRST USE 2-1-2011; IN COMMERCE 2-1-2011.

CLASS 35—(Continued).

4,016,334. WORKFORCETACTIX, INC., SPARKS, MD. SN 77-739,114. PUB. 10-6-2009, FILED 5-18-2009.

WORKFORCETACTIX

THE MARK CONSISTS OF STANDARD CHARACTERS WITHOUT CLAIM TO ANY PARTICULAR FONT, STYLE, SIZE, OR COLOR.

FOR CONSULTING SERVICES IN THE FIELD OF HUMAN RESOURCES DEVELOPMENT, NAMELY, UTILIZING TECHNOLOGY FOR THE PROMOTION OF EMPLOYEE RETENTION, CAREER GROWTH AND INCREASED PRODUCTIVITY FOR EMPLOYEES AND EMPLOYERS; COST MANAGEMENT FOR THE HEALTH CARE BENEFIT PLANS OF OTHERS; HUMAN RESOURCES CONSULTATION; HUMAN RESOURCES MANAGEMENT (U.S. CLS. 100, 101 AND 102).

FIRST USE 5-7-2010; IN COMMERCE 5-7-2010.

CLASS 35—(Continued).

4,016,380. DOTOMI, INC., CHICAGO, IL. SN 77-796,925. PUB. 5-18-2010, FILED 8-4-2009.



OWNER OF U.S. REG. NO. 3,276,082.

THE MARK CONSISTS OF A CRESCENT MOON MADE UP OF DOTTED LINES AND THE WORDS "DOTOMI" APPEARING IN BETWEEN THE TIPS OF THE CRESCENT MOON.

FOR DISSEMINATION OF ADVERTISING FOR OTHERS VIA THE INTERNET; PROMOTING THE GOODS AND SERVICES OF OTHERS BY MEANS OF DISTRIBUTING ADVERTISING ON THE INTERNET (U.S. CLS. 100, 101 AND 102).

FIRST USE 6-1-2010; IN COMMERCE 6-1-2010.

4,016,346. SUN LIFE ASSURANCE COMPANY OF CANADA, TORONTO, ONTARIO, CANADA. SN 77-750,822. PUB. 4-19-2011, FILED 6-3-2009.

EAP BY DESIGN

THE MARK CONSISTS OF STANDARD CHARACTERS WITHOUT CLAIM TO ANY PARTICULAR FONT, STYLE, SIZE, OR COLOR.

NO CLAIM IS MADE TO THE EXCLUSIVE RIGHT TO USE "EAP", APART FROM THE MARK AS SHOWN.

FOR EMPLOYEE ASSISTANCE PROGRAMS, NAMELY, REFERRALS IN THE FIELD OF LAW, FINANCE, HUMAN RESOURCES, ELDER CARE, HEALTH, WELLNESS, CRISIS MANAGEMENT, AND PARENTING; EMPLOYEE ASSISTANCE PROGRAMS, NAMELY, INFORMATION SERVICES TO ASSIST EMPLOYEES WITH PERSONAL AND WORK-LIFE CHALLENGES IN THE FIELD OF HUMAN RESOURCES (U.S. CLS. 100, 101 AND 102).

FIRST USE 6-8-2009; IN COMMERCE 6-8-2009.

4,016,411. DICKHOUT, CRAIG A, HUNTINGTON BEACH, CA. SN 77-841,833. PUB. 11-23-2010, FILED 10-5-2009.

J Letter

THE MARK CONSISTS OF STANDARD CHARACTERS WITHOUT CLAIM TO ANY PARTICULAR FONT, STYLE, SIZE, OR COLOR.

FOR ADVERTISING AND MARKETING; ADVERTISING, MARKETING AND PROMOTION SERVICES; BUSINESS MARKETING AND DIRECT MAIL CONSULTING SERVICES; BUSINESS TO BUSINESS DIRECT MARKETING SERVICES; DIRECT MAIL ADVERTISING; DIRECT MARKETING ADVERTISING FOR OTHERS; DIRECT MARKETING CONSULTING SERVICES; DIRECT MARKETING SERVICES (U.S. CLS. 100, 101 AND 102).

FIRST USE 1-1-2001; IN COMMERCE 1-1-2001.

CLASS 35—(Continued).

4,016,426. WOEBER MUSTARD MANUFACTURING COMPANY, SPRINGFIELD, OH. SN 77-863,780. PUB. 3-9-2010, FILED 11-3-2009.

CLASS 35—(Continued).

4,016,489. PIKE NURSERIES ACQUISITION, LLC, DULUTH, GA. SN 77-892,786. PUB. 11-9-2010, FILED 12-14-2009.

WAY MORE THAN MAYO

THE MARK CONSISTS OF STANDARD CHARACTERS WITHOUT CLAIM TO ANY PARTICULAR FONT, STYLE, SIZE, OR COLOR.

FOR MAIL ORDER SERVICES, RETAIL STORES AND DISTRIBUTORSHIPS FEATURING FLAVORED MAYONNAISE (U.S. CLS. 100, 101 AND 102).

FIRST USE 1-1-2010; IN COMMERCE 1-1-2010.

4,016,437. HAN, MICHAEL, WASHINGTON, DC. SN 77-871,298. PUB. 10-26-2010, FILED 11-12-2009.

Lyfcentric

THE MARK CONSISTS OF STANDARD CHARACTERS WITHOUT CLAIM TO ANY PARTICULAR FONT, STYLE, SIZE, OR COLOR.

FOR ELECTRONIC CATALOG SERVICES FEATURING NUTRACEUTICALS, BODY, BATH AND BEAUTY CARE PRODUCTS, WEIGHT LOSS PRODUCTS, BEVERAGES AND TECHNOLOGY PRODUCTS; ONLINE RETAIL STORE SERVICES FEATURING NUTRACEUTICALS, BODY, BATH AND BEAUTY CARE PRODUCTS, WEIGHT LOSS PRODUCTS, BEVERAGES AND TECHNOLOGY PRODUCTS (U.S. CLS. 100, 101 AND 102).

FIRST USE 7-15-2010; IN COMMERCE 7-15-2010.

4,016,465. ASSOCIATIONS, INC., DALLAS, TX. SN 77-884,933. PUB. 4-27-2010, FILED 12-2-2009.

ASSOCIA ADVANTAGE

THE MARK CONSISTS OF STANDARD CHARACTERS WITHOUT CLAIM TO ANY PARTICULAR FONT, STYLE, SIZE, OR COLOR.

FOR CONSUMER LOYALTY INCENTIVE PROGRAM, NAMELY, ADMINISTRATION OF A DISCOUNT PROGRAM FOR ENABLING PARTICIPATING MEMBERS TO OBTAIN DISCOUNTS AND REBATES ON HOUSEHOLD GOODS AND SERVICES (U.S. CLS. 100, 101 AND 102).

FIRST USE 3-3-2010; IN COMMERCE 3-3-2010.

PLAY IN THE DIRT CLUB

THE MARK CONSISTS OF STANDARD CHARACTERS WITHOUT CLAIM TO ANY PARTICULAR FONT, STYLE, SIZE, OR COLOR.

OWNER OF U.S. REG. NO. 2,005,587.

NO CLAIM IS MADE TO THE EXCLUSIVE RIGHT TO USE "CLUB", APART FROM THE MARK AS SHOWN.

FOR CUSTOMER LOYALTY SERVICES AND CUSTOMER CLUB SERVICES, FOR COMMERCIAL, PROMOTIONAL AND/OR ADVERTISING PURPOSES (U.S. CLS. 100, 101 AND 102).

FIRST USE 11-28-2008; IN COMMERCE 11-28-2008.

4,016,491. PIKE NURSERIES ACQUISITION, LLC, DULUTH, GA. SN 77-892,850. PUB. 11-9-2010, FILED 12-14-2009.

PLAY IN THE DIRT REWARDS PROGRAM

THE MARK CONSISTS OF STANDARD CHARACTERS WITHOUT CLAIM TO ANY PARTICULAR FONT, STYLE, SIZE, OR COLOR.

OWNER OF U.S. REG. NO. 2,005,587.

NO CLAIM IS MADE TO THE EXCLUSIVE RIGHT TO USE "REWARDS PROGRAM", APART FROM THE MARK AS SHOWN.

FOR CUSTOMER LOYALTY SERVICES AND CUSTOMER CLUB SERVICES, FOR COMMERCIAL, PROMOTIONAL AND/OR ADVERTISING PURPOSES (U.S. CLS. 100, 101 AND 102).

FIRST USE 11-28-2008; IN COMMERCE 11-28-2008.

CLASS 35—(Continued).

4,016,502. JUST FABULOUS, EL SEGUNDO, CA. SN 77-895,105. PUB. 5-4-2010, FILED 12-16-2009.



THE MARK CONSISTS OF THE LETTER "S" INSIDE A STYLIZED "U" SHAPE WITH THE WORDS "SHOE FABULOUS" UNDERNEATH.

FOR ONLINE RETAIL STORE SERVICES FEATURING SHOES AND FOOTWEAR (U.S. CLS. 100, 101 AND 102).

FIRST USE 2-0-2010; IN COMMERCE 2-0-2010.

CLASS 35—(Continued).

4,016,536. MCCABE, DENNIS, VIERA, FL. AND MCCABE, PAULA, VIERA, FL. SN 77-908,785. PUB. 6-1-2010, FILED 1-11-2010.

NERVE TO SERVE

THE MARK CONSISTS OF STANDARD CHARACTERS WITHOUT CLAIM TO ANY PARTICULAR FONT, STYLE, SIZE, OR COLOR.

FOR CHARITABLE SERVICES IN THE FIELD OF RELIGIOUS STUDIES, NAMELY, ORGANIZING AND CONDUCTING COMMUNITY SERVICE PROJECTS TO FOSTER STUDENT VOLUNTEERISM (U.S. CLS. 100, 101 AND 102).

FIRST USE 10-30-2010; IN COMMERCE 10-30-2010.

4,016,518. WIREWAVES, LLC, MULVANE, KS. SN 77-900,835. PUB. 11-23-2010, FILED 12-24-2009.

THE FILE HARMONIC

THE MARK CONSISTS OF STANDARD CHARACTERS WITHOUT CLAIM TO ANY PARTICULAR FONT, STYLE, SIZE, OR COLOR.

NO CLAIM IS MADE TO THE EXCLUSIVE RIGHT TO USE "FILE", APART FROM THE MARK AS SHOWN.

FOR PROVIDING AN ONLINE COMPUTER DATABASE FOR STRUCTURING PHYSICAL FILING SYSTEMS, NAMELY, COMPUTERIZED AND CENTRAL FILE MANAGEMENT FOR EITHER PERSONAL OR BUSINESS USE, AND BUSINESS FILE MANAGEMENT (U.S. CLS. 100, 101 AND 102).

FIRST USE 1-29-2011; IN COMMERCE 1-29-2011.

4,016,604. SIERRA HEALTHSTYLES LLC, TUCSON, AZ. SN 77-943,636. PUB. 11-2-2010, FILED 2-24-2010.

Authentic Circle

THE MARK CONSISTS OF STANDARD CHARACTERS WITHOUT CLAIM TO ANY PARTICULAR FONT, STYLE, SIZE, OR COLOR.

FOR RESORT AND SPA CUSTOMER LOYALTY PROGRAM AND CUSTOMER CLUB SERVICES, FOR PROMOTIONAL AND/OR ADVERTISING PURPOSES; CUSTOMER LOYALTY PROGRAM WHICH PROVIDES MEMBERS WITH PREMIUM SERVICES, DISCOUNTS, POINTS REDEEMABLE FOR HOTEL AND RESORT ACCOMMODATIONS, SPA SERVICES AND OTHER GOODS AND SERVICES, AND OTHER BENEFITS FOR COMMERCIAL, PROMOTIONAL AND ADVERTISING PURPOSES (U.S. CLS. 100, 101 AND 102).

FIRST USE 6-1-2011; IN COMMERCE 6-1-2011.

CLASS 35—(Continued).

4,016,605. SIERRA HEALTHSTYLES LLC, TUCSON, AZ. SN 77-943,651. PUB. 11-9-2010, FILED 2-24-2010.

STEP RUN FLY

THE MARK CONSISTS OF STANDARD CHARACTERS WITHOUT CLAIM TO ANY PARTICULAR FONT, STYLE, SIZE, OR COLOR.

FOR RESORT AND SPA CUSTOMER LOYALTY PROGRAM AND CUSTOMER CLUB SERVICES, FOR PROMOTIONAL AND/OR ADVERTISING PURPOSES; CUSTOMER LOYALTY PROGRAM WHICH PROVIDES MEMBERS WITH PREMIUM SERVICES, DISCOUNTS, POINTS REDEEMABLE FOR HOTEL AND RESORT ACCOMMODATIONS, SPA SERVICES AND OTHER GOODS AND SERVICES, AND OTHER BENEFITS FOR COMMERCIAL, PROMOTIONAL AND ADVERTISING PURPOSES (U.S. CLS. 100, 101 AND 102).

FIRST USE 6-1-2011; IN COMMERCE 6-1-2011.

4,016,606. FALKSON INC., VALHALLA, NY. SN 77-944,642. PUB. 7-27-2010, FILED 2-25-2010.



NO CLAIM IS MADE TO THE EXCLUSIVE RIGHT TO USE "SALE LOCATOR", APART FROM THE MARK AS SHOWN.

THE MARK CONSISTS OF THE WORDS "SALE LOCATOR" IN A STYLIZED FONT AND A SALES TAG BEHIND THE WORD "SALE" WITH A STRING REACHING TO THE "O" IN "LOCATOR".

FOR PROVIDING INFORMATION PERTAINING TO PROCUREMENT, BUYING, SELLING AND TENDERING INFORMATION AND OPPORTUNITIES RELATING TO GOODS, SERVICES, AND CONSTRUCTION VIA COMPUTER, COMPUTER NETWORKS, TELEPHONE, THE INTERNET OR ELECTRONIC MAIL (U.S. CLS. 100, 101 AND 102).

FIRST USE 11-1-2010; IN COMMERCE 2-18-2011.

4,016,608. BERNARD SCHUMACHER, BISMARCK, ND. SN 77-945,267. PUB. 8-24-2010, FILED 2-25-2010.

PROMISE ME JEWELERS

THE MARK CONSISTS OF STANDARD CHARACTERS WITHOUT CLAIM TO ANY PARTICULAR FONT, STYLE, SIZE, OR COLOR.

NO CLAIM IS MADE TO THE EXCLUSIVE RIGHT TO USE "JEWELERS", APART FROM THE MARK AS SHOWN.

FOR ON-LINE WHOLESALE AND RETAIL STORE SERVICES FEATURING JEWELRY; WHOLESALE AND RETAIL STORE SERVICES FEATURING JEWELRY (U.S. CLS. 100, 101 AND 102).

FIRST USE 4-5-2011; IN COMMERCE 4-5-2011.

CLASS 35—(Continued).

4,016,617. DPZ PROPERTIES, INC., DURHAM, NC. SN 77-946,737. PUB. 8-17-2010, FILED 2-28-2010.

CAPITAL FITNESS

THE MARK CONSISTS OF STANDARD CHARACTERS WITHOUT CLAIM TO ANY PARTICULAR FONT, STYLE, SIZE, OR COLOR.

NO CLAIM IS MADE TO THE EXCLUSIVE RIGHT TO USE "FITNESS", APART FROM THE MARK AS SHOWN.

FOR RETAIL SPORTING GOODS STORES; RETAIL STORE SERVICES FEATURING SPORTING GOODS (U.S. CLS. 100, 101 AND 102).

FIRST USE 8-31-2010; IN COMMERCE 8-31-2010.

4,016,622. SOLEMATES LLC, WASHINGTON, DC. SN 77-947,971. PUB. 11-9-2010, FILED 3-2-2010.

STYLISH OBSESSIONS

THE MARK CONSISTS OF STANDARD CHARACTERS WITHOUT CLAIM TO ANY PARTICULAR FONT, STYLE, SIZE, OR COLOR.

FOR RETAIL STORE SERVICES FEATURING CLOTHING, SHOES, HOSIERY, SOCKS, AND ACCESSORIES, NAMELY, HANDBAGS, JEWELRY, HATS, SCARVES AND BELTS; ON-LINE RETAIL STORE SERVICES FEATURING CLOTHING, SHOES, HOSIERY, SOCKS, AND ACCESSORIES, NAMELY, HANDBAGS, JEWELRY, HATS, SCARVES AND BELTS; AND MAIL ORDER CATALOG SERVICES FEATURING CLOTHING, SHOES, HOSIERY, SOCKS, AND ACCESSORIES, NAMELY, HANDBAGS, JEWELRY, HATS, SCARVES AND BELTS (U.S. CLS. 100, 101 AND 102).

FIRST USE 8-28-2010; IN COMMERCE 8-28-2010.

CLASS 35—(Continued).

4,016,623. ECOOUTFITTERS.NET, LLC C/O RAINA RUSSO, ATLANTIC BEACH, NY. SN 77-948,557. PUB. 10-12-2010, FILED 3-2-2010.



THE MARK CONSISTS OF THE WORD "ECOOUTFITTERS.NET" WITH THE SECOND "O" IN THE FORM OF A STYLIZED ARROW IN A CIRCULAR SHAPE AND A LEAF DESIGN ABOVE THE LETTERS "R" AND "S".

FOR MARKETING, ADVERTISING AND BUSINESS CONSULTATION SERVICES TO CONSUMERS, MANUFACTURERS, AND SELLERS IN THE AREA OF ALTERNATIVE, GREEN ENERGY AND OTHER EARTH FRIENDLY TECHNOLOGY SOLUTIONS VIA A GLOBAL COMPUTER INFORMATION NETWORK AND OTHER SOURCES; PROVIDING LEAD GENERATION AND OTHER MARKETING SERVICES TO CONSUMERS, MANUFACTURERS, AND SELLERS OF ALTERNATIVE, GREEN ENERGY AND OTHER EARTH FRIENDLY TECHNOLOGY SOLUTIONS (U.S. CLS. 100, 101 AND 102).

FIRST USE 6-3-2011; IN COMMERCE 6-3-2011.

4,016,667. GATES, JOHN FITZGERALD, DBA CRITICALITY MANAGEMENT CONSULTING, NEW YORK, NY. SN 77-970,143. PUB. 8-24-2010, FILED 3-26-2010.

Criticality Management Consulting

THE MARK CONSISTS OF STANDARD CHARACTERS WITHOUT CLAIM TO ANY PARTICULAR FONT, STYLE, SIZE, OR COLOR.

NO CLAIM IS MADE TO THE EXCLUSIVE RIGHT TO USE "MANAGEMENT CONSULTING", APART FROM THE MARK AS SHOWN.

FOR BUSINESS ADMINISTRATION CONSULTANCY; BUSINESS ADVISORY SERVICES, CONSULTANCY AND INFORMATION; BUSINESS CONSULTATION IN THE FIELD OF BUSINESS LEADERSHIP DEVELOPMENT; BUSINESS MANAGEMENT CONSULTING; BUSINESS MANAGEMENT CONSULTING IN THE FIELD OF TEAM DEVELOPMENT (U.S. CLS. 100, 101 AND 102).

FIRST USE 6-1-2010; IN COMMERCE 7-1-2010.

CLASS 35—(Continued).

4,016,728. GIANTOMAS INC., OVIEDO, FL. SN 85-002,747. PUB. 3-15-2011, FILED 3-31-2010.

TOMASINO'S NEW YORK PIZZERIA

THE MARK CONSISTS OF STANDARD CHARACTERS WITHOUT CLAIM TO ANY PARTICULAR FONT, STYLE, SIZE, OR COLOR.

NO CLAIM IS MADE TO THE EXCLUSIVE RIGHT TO USE "NEW YORK PIZZERIA", APART FROM THE MARK AS SHOWN.

FOR ADVICE IN THE RUNNING OF ESTABLISHMENTS AS FRANCHISES; BUSINESS MANAGEMENT ADVISORY SERVICES RELATING TO FRANCHISING; FRANCHISING, NAMELY, CONSULTATION AND ASSISTANCE IN BUSINESS MANAGEMENT, ORGANIZATION AND PROMOTION; FRANCHISING, NAMELY, OFFERING BUSINESS MANAGEMENT ASSISTANCE IN THE ESTABLISHMENT AND/OR OPERATION OF PIZZERIAS (U.S. CLS. 100, 101 AND 102).

FIRST USE 4-12-2011; IN COMMERCE 4-12-2011.

4,016,732. METALLIX DIRECT GOLD, LLC, SHREWSBURY, NJ. SN 85-003,886. PUB. 10-5-2010, FILED 4-1-2010.

Metallix Direct Gold

THE MARK CONSISTS OF STANDARD CHARACTERS WITHOUT CLAIM TO ANY PARTICULAR FONT, STYLE, SIZE, OR COLOR.

NO CLAIM IS MADE TO THE EXCLUSIVE RIGHT TO USE "DIRECT GOLD", APART FROM THE MARK AS SHOWN.

FOR SCRAP DEALERSHIPS FEATURING RECYCLED GOLD (U.S. CLS. 100, 101 AND 102).

FIRST USE 4-30-2010; IN COMMERCE 4-30-2010.

4,016,743. JUNIOR LEARNING INCORPORATED, DBA JUNIOR LEARNING INCORPORATED, HUNTINGTON BEACH, CA. SN 85-008,015. PUB. 9-7-2010, FILED 4-7-2010.



NO CLAIM IS MADE TO THE EXCLUSIVE RIGHT TO USE "JUNIOR LEARNING", APART FROM THE MARK AS SHOWN.

THE COLOR(S) RED AND WHITE IS/ARE CLAIMED AS A FEATURE OF THE MARK.

CLASS 35—(Continued).

THE MARK CONSISTS OF THE WORDING "JUNIOR LEARNING" IN RED IN A ROUNDED SANS SERIF FONT WITH A CARTOON IMAGE OF A YOUNG BOY'S FACE AND HANDS PEERING OVER THE WORD. A SINGLE-LINE RED OUTLINE IN A SLOPED PARALLELOGRAM SHAPE SURROUNDS THE WORDING AND DESIGN AND THE BACKGROUND IS WHITE.

FOR ONLINE RETAIL STORE SERVICES, ONLINE DISTRIBUTORSHIP SERVICES AND MAIL ORDER CATALOGUE SERVICES FEATURING INNOVATIVE EDUCATIONAL MATERIALS FOR SCHOOL AGE CHILDREN, NAMELY, EDUCATIONAL TOOLS AND TEACHING MATERIALS FOR MATHEMATICS AND READING IN THE NATURE OF PLASTIC SHAPE BOARD GAMES, PLASTIC SHAPE MANIPULATIVE PUZZLES, PLASTIC SHAPED EDUCATIONAL TOYS AND PRINTED TEACHING AIDS (U.S. CLS. 100, 101 AND 102).

FIRST USE 12-1-2010; IN COMMERCE 1-1-2011.

4,016,745. DIVA ROSES, INC., MIAMI, FL. SN 85-009,890. PUB. 8-31-2010, FILED 4-8-2010.

DIVA ROSES

THE MARK CONSISTS OF STANDARD CHARACTERS WITHOUT CLAIM TO ANY PARTICULAR FONT, STYLE, SIZE, OR COLOR.

NO CLAIM IS MADE TO THE EXCLUSIVE RIGHT TO USE "ROSES", APART FROM THE MARK AS SHOWN.

FOR RETAIL AND ONLINE STORE SERVICES FEATURING FLOWERS, FLORAL ARRANGEMENTS, FLOWER BASKETS AND RELATED GIFT CARDS (U.S. CLS. 100, 101 AND 102).

FIRST USE 4-1-2011; IN COMMERCE 4-1-2011.

4,016,763. TRACFONE WIRELESS, INC., MIAMI, FL. SN 85-018,418. PUB. 9-21-2010, FILED 4-20-2010.

**THE LONGER YOU STAY THE
LESS YOU PAY**

THE MARK CONSISTS OF STANDARD CHARACTERS WITHOUT CLAIM TO ANY PARTICULAR FONT, STYLE, SIZE, OR COLOR.

FOR ONLINE RETAIL STORE SERVICES FEATURING CELLULAR TELEPHONES, PREPAID WIRELESS AIR TIME CARDS, CELLULAR TELEPHONE ACCESSORIES AND WIRELESS SERVICES; DISTRIBUTORSHIP SERVICES FEATURING CELLULAR TELEPHONES, PREPAID AIR TIME CELLULAR TELEPHONE AND PREPAID AIR TIME DEBIT CARDS AND SOFTWARE FOR CONTROLLING AND MONITORING PREPAID AIR TIME CELLULAR SERVICE (U.S. CLS. 100, 101 AND 102).

FIRST USE 5-27-2011; IN COMMERCE 5-27-2011.

CLASS 35—(Continued).

4,016,769. V & H HOLDINGS LLC, GILBERT, AZ. SN 85-022,648. PUB. 10-5-2010, FILED 4-26-2010.



THE MARK CONSISTS OF A SWIRL DESIGN IN THE NATURE OF A HEART WITH A LOOP AT THE TOP AND BOTTOM CENTER OF THE HEART.

FOR ADVERTISING AND PROMOTIONAL SERVICES; PROMOTING THE GOODS AND SERVICES OF OTHERS BY PROVIDING A WEB SITE FEATURING COUPONS, REBATES, PRODUCT REVIEWS, LINKS TO THE RETAIL WEB SITES OF OTHERS, AND DISCOUNT INFORMATION (U.S. CLS. 100, 101 AND 102).

FIRST USE 7-26-2010; IN COMMERCE 11-16-2010.

4,016,777. FIRST SERVICE NETWORKS, INC., LINTHICUM, MD. SN 85-025,938. PUB. 10-5-2010, FILED 4-29-2010.

FUSION

THE MARK CONSISTS OF STANDARD CHARACTERS WITHOUT CLAIM TO ANY PARTICULAR FONT, STYLE, SIZE, OR COLOR.

OWNER OF U.S. REG. NOS. 2,617,357, 2,737,955, AND OTHERS.

FOR TECHNICAL FACILITIES MANAGEMENT SERVICES, NAMELY, PLACING, MONITORING, PROCESSING, AND INVOICING MAINTENANCE, REPAIR, AND INSTALLATION ORDERS VIA AN INTERACTIVE WEBSITE FOR USE BY CUSTOMERS, DISPATCHERS, SERVICE CONTRACTORS, AND TECHNICIANS (U.S. CLS. 100, 101 AND 102).

FIRST USE 4-27-2010; IN COMMERCE 4-27-2010.

CLASS 35—(Continued).

4,016,778. FIRST SERVICE NETWORKS, INC., LINTHICUM, MD. SN 85-025,941. PUB. 10-5-2010, FILED 4-29-2010.



OWNER OF U.S. REG. NOS. 2,617,357, 2,737,955, AND OTHERS.

THE MARK CONSISTS OF THE WORD "FUSION" WITH AN ATOMIC SYMBOL DESIGN AROUND THE LETTER "O".

FOR TECHNICAL FACILITIES MANAGEMENT SERVICES, NAMELY, PLACING, MONITORING, PROCESSING, AND INVOICING MAINTENANCE, REPAIR, AND INSTALLATION ORDERS VIA AN INTERACTIVE WEBSITE FOR USE BY CUSTOMERS, DISPATCHERS, SERVICE CONTRACTORS, AND TECHNICIANS (U.S. CLS. 100, 101 AND 102).

FIRST USE 4-27-2010; IN COMMERCE 4-27-2010.

4,016,786. FITCREW INDUSTRIAL CORP., TAIPING, TAIWAN. SN 85-029,297. PUB. 11-16-2010, FILED 5-4-2010.

FITCREW

THE MARK CONSISTS OF STANDARD CHARACTERS WITHOUT CLAIM TO ANY PARTICULAR FONT, STYLE, SIZE, OR COLOR.

OWNER OF U.S. REG. NO. 2,795,892.

FOR COMPUTERIZED ON-LINE ORDERING SERVICES IN THE FIELD OF COSMETICS, SUNGLASSES, CLOTHING, SPORTING EQUIPMENT AND GYMNAS-TIC APPARATUS; CUSTOMER SERVICE IN THE FIELD OF RETAIL STORE SERVICES; MAIL ORDER CATALOG SERVICES FEATURING COSMETICS, SUNGLASSES, CLOTHING, SPORTING EQUIPMENT AND GYMNAS-TIC APPARATUS; ON-LINE AUCTION SERVICES; ON-LINE AUCTIONEERING SERVICES VIA THE INTERNET; PRESENTATION OF GOODS ON COMMUN-ICATION MEDIA FOR RETAIL PURPOSES; PROMOT-ING THE GOODS OF OTHERS BY MEANS OF ON-LINE REAL TIME PRESENTATION FOR INSPECTION, VIEW-ING OR SHOWING OF COSMETICS, SUNGLASSES, CLOTHING, SPORTING EQUIPMENT AND GYMNAS-TIC APPARATUS; PROVIDING A WEBSITE USED TO PLACE ON-LINE COMMERCIAL ORDERS IN THE FIELD OF COSMETICS, SUNGLASSES, CLOTHING, SPORTING EQUIPMENT AND GYMNAS-TIC APPARA-TUS (U.S. CLS. 100, 101 AND 102).

FIRST USE 3-22-2010; IN COMMERCE 9-16-2010.

CLASS 35—(Continued).

4,016,789. OROLATINA LLC, CLIFTON, NJ. SN 85-033,313. PUB. 10-19-2010, FILED 5-7-2010.

PLATALATINA

THE MARK CONSISTS OF STANDARD CHARACTERS WITHOUT CLAIM TO ANY PARTICULAR FONT, STYLE, SIZE, OR COLOR.

OWNER OF U.S. REG. NOS. 3,311,543 AND 3,550,812.

FOR ELECTRONIC CATALOG SERVICES FEATUR-ING JEWELRY AND WATCHES; ON-LINE RETAIL STORE SERVICES FEATURING JEWELRY AND WATCHES (U.S. CLS. 100, 101 AND 102).

FIRST USE 6-13-2011; IN COMMERCE 6-13-2011.

4,016,818. UHS OF DELAWARE, INC., KING OF PRUSSIA, PA. SN 85-041,788. PUB. 11-2-2010, FILED 5-18-2010.



NO CLAIM IS MADE TO THE EXCLUSIVE RIGHT TO USE "SHOPPE", APART FROM THE MARK AS SHOWN.

THE MARK CONSISTS OF THE WORDS "SHOPPE ON THE RIVER" ABOVE TWO WAVY LINES, WITH A PARTIAL SUNBURST IN THE BACKGROUND ABOVE THE WAVY LINES.

FOR RETAIL STORE AND GIFT SHOP SERVICES (U.S. CLS. 100, 101 AND 102).

FIRST USE 5-15-2010; IN COMMERCE 5-15-2010.

4,016,859. PRACTICAL SYSTEMS LIMITED, NASSAU, BA-HAMAS. SN 85-052,903. PUB. 11-2-2010, FILED 6-2-2010.

CONFIGURATOR

THE MARK CONSISTS OF STANDARD CHARACTERS WITHOUT CLAIM TO ANY PARTICULAR FONT, STYLE, SIZE, OR COLOR.

FOR PROVIDING A WEB-BASED SYSTEM AND ON-LINE PORTAL IN THE FIELD OF CONSUMER-TO-BUSINESS COMMERCE THAT ALLOWS CONSUMERS TO RESEARCH MULTIPLE BRANDS OF NEW AND USED VEHICLES, VIEW HIGH RESOLUTION IMAGES OF VEHICLES, AND COMPARE VEHICLE FEATURES AND PRICING (U.S. CLS. 100, 101 AND 102).

FIRST USE 8-13-2010; IN COMMERCE 8-13-2010.

CLASS 35—(Continued).

4,016,894. ZEN-OHS BOTANICALS INCORPORATED, NORTH BELLMORE, NY. SN 85-061,854. PUB. 11-16-2010, FILED 6-14-2010.

HEALTHY PEOPLE ARE HAPPIER!

THE MARK CONSISTS OF STANDARD CHARACTERS WITHOUT CLAIM TO ANY PARTICULAR FONT, STYLE, SIZE, OR COLOR.

FOR WHOLESALE AND RETAIL STORE SERVICES, ONLINE WHOLESALE AND RETAIL STORE SERVICES, ADVERTISING AND MARKETING SERVICES; ALL IN THE FIELDS OF DIETARY SUPPLEMENTS (U.S. CLS. 100, 101 AND 102).

FIRST USE 7-0-2010; IN COMMERCE 7-0-2010.

4,016,897. CONTIGO SYSTEMS INC., VANCOUVER, CANADA. SN 85-062,749. PUB. 11-16-2010, FILED 6-15-2010.

RIDE ALONG

THE MARK CONSISTS OF STANDARD CHARACTERS WITHOUT CLAIM TO ANY PARTICULAR FONT, STYLE, SIZE, OR COLOR.

FOR TRACKING, LOCATING AND MONITORING VEHICLES FOR COMMERCIAL PURPOSES, USING WIRELESS COMMUNICATIONS DEVICES VIA A GLOBAL COMPUTER NETWORK (U.S. CLS. 100, 101 AND 102).

FIRST USE 7-27-2010; IN COMMERCE 6-20-2011.

4,016,926. SHEN, JIN WEN, SHORT HILLS, NJ. SN 85-068,645. PUB. 11-16-2010, FILED 6-22-2010.

GKP

THE MARK CONSISTS OF STANDARD CHARACTERS WITHOUT CLAIM TO ANY PARTICULAR FONT, STYLE, SIZE, OR COLOR.

FOR PROVIDING INFORMATION AND ANALYSIS IN THE FIELDS OF ECONOMICS AND BUSINESS (U.S. CLS. 100, 101 AND 102).

FIRST USE 2-1-2011; IN COMMERCE 5-1-2011.

CLASS 35—(Continued).

4,016,938. NOBLE LION STORES, STOCKTON, CA. SN 85-070,495. PUB. 12-14-2010, FILED 6-24-2010.



NO CLAIM IS MADE TO THE EXCLUSIVE RIGHT TO USE "SECURITY", APART FROM THE MARK AS SHOWN. THE MARK CONSISTS OF TWO ROOFS WITH THE STYLIZED TEXT "SLYFOXX SECURITY" WITH THE "S" AS THE TAIL AND THE "X" AS THE HEAD OF A FOX.

FOR ON-LINE RETAIL STORE SERVICES FEATURING HOME VIDEO SURVEILLANCE AND PERSONAL SECURITY EQUIPMENT (U.S. CLS. 100, 101 AND 102).

FIRST USE 9-1-2010; IN COMMERCE 10-25-2010.

4,016,981. GREAT AMERICAN GROUP, LLC, WOODLAND HILLS, CA. SN 85-082,413. PUB. 12-28-2010, FILED 7-12-2010.

MAXIMIZING ASSETS /
MINIMIZING DOUBT

THE MARK CONSISTS OF STANDARD CHARACTERS WITHOUT CLAIM TO ANY PARTICULAR FONT, STYLE, SIZE, OR COLOR.

FOR ARRANGING AND CONDUCTING AUCTIONS IN THE FIELD OF INVENTORY AND FIXED ASSETS OF OTHERS; INVENTORY MANAGEMENT SERVICES; BUSINESS APPRAISAL, NAMELY, APPRAISAL OF INVENTORY AND FIXED ASSETS OF OTHERS (U.S. CLS. 100, 101 AND 102).

FIRST USE 7-6-2011; IN COMMERCE 7-6-2011.

CLASS 35—(Continued).

4,016,982. GREAT AMERICAN GROUP, LLC, WOODLAND HILLS, CA. SN 85-082,432. PUB. 12-28-2010, FILED 7-12-2010.

CHANGING THE WAY YOU CHANGE YOUR BUSINESS

THE MARK CONSISTS OF STANDARD CHARACTERS WITHOUT CLAIM TO ANY PARTICULAR FONT, STYLE, SIZE, OR COLOR.

FOR ARRANGING AND CONDUCTING AUCTIONS IN THE FIELD OF INVENTORY AND FIXED ASSETS OF OTHERS; INVENTORY MANAGEMENT SERVICES; BUSINESS APPRAISAL, NAMELY, APPRAISAL OF INVENTORY AND FIXED ASSETS OF OTHERS (U.S. CLS. 100, 101 AND 102).

FIRST USE 6-24-2011; IN COMMERCE 6-24-2011.

4,017,012. NATIONAL MONEY LLC, BOCA RATON, FL. SN 85-089,813. PUB. 12-14-2010, FILED 7-21-2010.

MONEY NATIONAL

THE MARK CONSISTS OF STANDARD CHARACTERS WITHOUT CLAIM TO ANY PARTICULAR FONT, STYLE, SIZE, OR COLOR.

NO CLAIM IS MADE TO THE EXCLUSIVE RIGHT TO USE "NATIONAL", APART FROM THE MARK AS SHOWN.

FOR PROVIDING DEMAND CREATION AND LEAD GENERATION ACTIVITIES AND SERVICES; BUSINESS MARKETING SERVICES, NAMELY, PROVIDING LEAD GENERATION (U.S. CLS. 100, 101 AND 102).

FIRST USE 9-17-2010; IN COMMERCE 9-17-2010.

4,017,015. UNIVERSAL CITY STUDIOS LLC, UNIVERSAL CITY, CA. SN 85-090,947. PUB. 10-26-2010, FILED 7-22-2010.

TEXT FOR TREES

THE MARK CONSISTS OF STANDARD CHARACTERS WITHOUT CLAIM TO ANY PARTICULAR FONT, STYLE, SIZE, OR COLOR.

FOR PROMOTING THE AWARENESS OF ISSUES RELATED TO THE ENVIRONMENT, CONSERVATION AND SUSTAINABILITY PRACTICES (U.S. CLS. 100, 101 AND 102).

FIRST USE 12-0-2009; IN COMMERCE 12-0-2009.

CLASS 35—(Continued).

4,017,026. THEAS.COM, LLC, DBA HANGITUP.COM, LEE'S SUMMIT, MO. SN 85-093,551. PUB. 4-5-2011, FILED 7-27-2010.

 The logo for Hangitup features the word "Hangitup" in a sans-serif font. The letters "HANG" are in orange, and "ITUP" are in gray. A stylized orange hanger shape is positioned below the "G" in "HANG".

THE COLOR(S) GRAY AND ORANGE IS/ARE CLAIMED AS A FEATURE OF THE MARK.

THE MARK CONSISTS OF THE WORDS "HANG" AND "UP" IN ORANGE WITH THE WORD "IT" IN GRAY BETWEEN THEM, WITH THE BOTTOM OF THE LETTER "G" IN THE WORD "HANG" APPEARING SIMILAR TO A HANGER.

FOR OPERATING ON-LINE MARKETPLACES FEATURING NEW AND USED CLOTHING, SHOES AND ACCESSORIES; OPERATING ON-LINE MARKETPLACES FOR SELLERS OF GOODS AND/OR SERVICES (U.S. CLS. 100, 101 AND 102).

FIRST USE 5-2-2011; IN COMMERCE 5-2-2011.

4,017,027. THEAS.COM, LLC, DBA HANGITUP.COM, LEE'S SUMMIT, MO. SN 85-093,574. PUB. 4-5-2011, FILED 7-27-2010.

 A stylized orange logo consisting of a large, rounded letter 'G' with a thick stroke. The bottom of the 'G' is open and curves back up to form a shape similar to a hanger.

THE COLOR(S) ORANGE IS/ARE CLAIMED AS A FEATURE OF THE MARK.

THE MARK CONSISTS OF THE LETTER "G" IN ORANGE WITH THE BOTTOM OF THE LETTER "G" APPEARING SIMILAR TO A HANGER.

FOR OPERATING ON-LINE MARKETPLACES FEATURING NEW AND USED CLOTHING, SHOES AND ACCESSORIES; OPERATING ON-LINE MARKETPLACES FOR SELLERS OF GOODS AND/OR SERVICES (U.S. CLS. 100, 101 AND 102).

FIRST USE 5-2-2011; IN COMMERCE 5-2-2011.

CLASS 35—(Continued).

4,017,037. CARRIER CORPORATION, FARMINGTON, CT. SN 85-099,789. PUB. 1-18-2011, FILED 8-4-2010.

WHAT ARE YOU WORKING ON
TODAY?

THE MARK CONSISTS OF STANDARD CHARACTERS WITHOUT CLAIM TO ANY PARTICULAR FONT, STYLE, SIZE, OR COLOR.

FOR RETAIL STORE SERVICES AND CATALOG ORDERING SERVICES FEATURING HEATING, VENTILATING, AIR CONDITIONING, AND REFRIGERATION (HVAC/R) REPLACEMENT PARTS, SUPPLIES, TOOLS, EQUIPMENT AND ACCESSORIES (U.S. CLS. 100, 101 AND 102).

FIRST USE 1-4-2010; IN COMMERCE 1-4-2010.

4,017,039. AMERICAN PUBLIC TRANSPORTATION ASSOCIATION, WASHINGTON, DC. SN 85-099,944. PUB. 1-25-2011, FILED 8-4-2010.

PUBLIC TRANSPORTATION
TAKES US THERE

THE MARK CONSISTS OF STANDARD CHARACTERS WITHOUT CLAIM TO ANY PARTICULAR FONT, STYLE, SIZE, OR COLOR.

NO CLAIM IS MADE TO THE EXCLUSIVE RIGHT TO USE "PUBLIC TRANSPORTATION", APART FROM THE MARK AS SHOWN.

FOR PROMOTING PUBLIC AWARENESS OF THE BENEFITS OF PUBLIC TRANSPORTATION (U.S. CLS. 100, 101 AND 102).

FIRST USE 3-4-2009; IN COMMERCE 3-4-2009.

4,017,040. AMERICAN PUBLIC TRANSPORTATION ASSOCIATION, WASHINGTON, DC. SN 85-099,946. PUB. 1-25-2011, FILED 8-4-2010.



NO CLAIM IS MADE TO THE EXCLUSIVE RIGHT TO USE "PUBLIC TRANSPORTATION", APART FROM THE MARK AS SHOWN.

THE COLOR(S) BLACK, BLUE, GREEN, RED AND YELLOW IS/ARE CLAIMED AS A FEATURE OF THE MARK.

THE MARK CONSISTS OF THE WORDING "PUBLIC TRANSPORTATION TAKES US THERE" IN BLACK, THE

CLASS 35—(Continued).

WORD "ECONOMY" IN BLUE, THE WORD "ENVIRONMENT" IN GREEN, THE WORD "ENERGY" IN RED, AND THE WORDS "QUALITY OF LIFE" IN YELLOW. A SEGMENTED, HORIZONTAL LINE DIVIDES UPPER AND LOWER PORTIONS OF THE MARK, WHEREIN THE LINE COMPRISES BLUE, GREEN, RED AND YELLOW SEGMENTS, SEPARATED BY BLACK CIRCLES. THE WORDS "ECONOMY ENVIRONMENT ENERGY" AND "QUALITY OF LIFE" ARE SEPARATED FROM ONE ANOTHER BY SMALL BLACK TRIANGLES.

FOR PROMOTING PUBLIC AWARENESS OF THE BENEFITS OF PUBLIC TRANSPORTATION (U.S. CLS. 100, 101 AND 102).

FIRST USE 3-4-2009; IN COMMERCE 3-4-2009.

4,017,068. FRAZILLA LLC, DALLAS, TX. SN 85-108,403. PUB. 1-25-2011, FILED 8-16-2010.

Frazilla

THE MARK CONSISTS OF STANDARD CHARACTERS WITHOUT CLAIM TO ANY PARTICULAR FONT, STYLE, SIZE, OR COLOR.

FOR ARRANGING AND CONDUCTING AUCTIONS (U.S. CLS. 100, 101 AND 102).

FIRST USE 1-15-2011; IN COMMERCE 4-5-2011.

4,017,073. LYLE, STEPHEN M., LOS ANGELES, CA. SN 85-110,156. PUB. 3-8-2011, FILED 8-18-2010.



NO CLAIM IS MADE TO THE EXCLUSIVE RIGHT TO USE "TIETRADER", APART FROM THE MARK AS SHOWN.

THE MARK CONSISTS OF A BEAR ON THE LEFT STANDING ON IT'S HIND LEGS AND A BULL ON THE RIGHT WITH A NECKTIE TIED AROUND ONE HORN. THE BEAR HAS THE END OF THE NECKTIE IN ITS MOUTH AND THE BULL AND THE BEAR ARE FIGHTING OVER IT. THE NECKTIE IS BETWEEN THE BEAR AND THE BULL. THE STYLIZED TEXT "TIETRADER" APPEARS BELOW.

FOR RETAIL STORE AND ON-LINE RETAIL STORE SERVICES FEATURING NECKTIES, CUFFLINKS, POCKET SQUARES, MEN'S CLOTHING AND ACCESSORIES (U.S. CLS. 100, 101 AND 102).

FIRST USE 10-1-2010; IN COMMERCE 12-1-2010.

CLASS 35—(Continued).

4,017,087. BLUESTEM BRANDS, INC., EDEN PRAIRIE, MN.
SN 85-115,142. PUB. 2-8-2011, FILED 8-25-2010.

FINGERHUT FRESHSTART

THE MARK CONSISTS OF STANDARD CHARACTERS WITHOUT CLAIM TO ANY PARTICULAR FONT, STYLE, SIZE, OR COLOR.

FOR ONLINE RETAIL AND MAIL-ORDER CATALOG SERVICES IN THE FIELD OF GENERAL CONSUMER MERCHANDISE (U.S. CLS. 100, 101 AND 102).

FIRST USE 8-25-2010; IN COMMERCE 8-25-2010.

4,017,090. STEIN MART HOLDING CORP., JACKSONVILLE, FL. SN 85-115,642. PUB. 11-23-2010, FILED 8-25-2010.

STEIN MART MAS ESTILO A
MENOS PRECIO

THE MARK CONSISTS OF STANDARD CHARACTERS WITHOUT CLAIM TO ANY PARTICULAR FONT, STYLE, SIZE, OR COLOR.

NO CLAIM IS MADE TO THE EXCLUSIVE RIGHT TO USE "MART", APART FROM THE MARK AS SHOWN.

THE ENGLISH TRANSLATION OF "MAS ESTILO A MENOS PRECIO" IN THE MARK IS MORE FASHION LESS PRICE.

FOR RETAIL DEPARTMENT STORE SERVICES (U.S. CLS. 100, 101 AND 102).

FIRST USE 3-31-2011; IN COMMERCE 3-31-2011.

CLASS 35—(Continued).

4,017,095. BRIDGMAN, WILLIAM, NORTHFIELD, IL. SN 85-118,594. PUB. 2-22-2011, FILED 8-30-2010.



The Public Check on Congress

THE MARK CONSISTS OF THE ARTISTIC RENDERING OF THE UNITED STATES CAPITOL BUILDING WITH THE OUTLINE OF CLOUDS APPEARING BEHIND THE CAPITOL. APPEARING OVER THE ARTISTIC RENDERING IS A CHECK MARK. APPEARING BELOW THE AFOREMENTIONED ARE THE STYLIZED WORDS "THE PUBLIC CHECK ON CONGRESS".

FOR ASSOCIATION SERVICES, NAMELY, PROMOTING THE INTERESTS OF CITIZENS WHO WANT A MORE EFFECTIVE AND EFFICIENT GOVERNMENT; POLITICAL CONSULTANCY; PROVIDING A WEBSITE FEATURING INFORMATION ABOUT POLITICAL ISSUES (U.S. CLS. 100, 101 AND 102).

FIRST USE 6-16-2011; IN COMMERCE 6-16-2011.

4,017,115. HUDSON GROUP (HG) RETAIL LLC, EAST RUTHERFORD, NJ. SN 85-128,999. PUB. 4-26-2011, FILED 9-14-2010.

TECH ON THE GO

THE MARK CONSISTS OF STANDARD CHARACTERS WITHOUT CLAIM TO ANY PARTICULAR FONT, STYLE, SIZE, OR COLOR.

NO CLAIM IS MADE TO THE EXCLUSIVE RIGHT TO USE "TECH", APART FROM THE MARK AS SHOWN.

FOR RETAIL STORE SERVICES FEATURING PERSONAL ELECTRONIC DEVICES AND RELATED ACCESSORIES, NAMELY, MP3 PLAYERS, DVD PLAYERS, CAMERAS, GPS NAVIGATION SYSTEMS, ELECTRONIC GAMES, HEADPHONES, LUGGAGE, BACKPACKS, TOTE BAGS, SATCHELS, COMPUTER AND LAPTOP ACCESSORIES (U.S. CLS. 100, 101 AND 102).

FIRST USE 8-13-2009; IN COMMERCE 8-13-2009.

CLASS 35—(Continued).

4,017,130. KARAPETYAN, TIRAN, YEREVAN, ARMENIA.
SN 85-134,168. PUB. 3-29-2011, FILED 9-21-2010.

ROOSHE

THE MARK CONSISTS OF STANDARD CHARACTERS WITHOUT CLAIM TO ANY PARTICULAR FONT, STYLE, SIZE, OR COLOR.

THE WORDING "ROOSHE" HAS NO MEANING IN A FOREIGN LANGUAGE.

FOR ADVERTISING SERVICES, NAMELY, ADVERTISING AGENCIES, UPDATING ADVERTISING MATERIAL, DISSEMINATION OF ADVERTISING MATTER, RENTING ADVERTISING SPACE, DIRECT MAIL ADVERTISING, ORGANIZING EXHIBITIONS FOR COMMERCIAL OR ADVERTISING PURPOSES, LAYOUT SERVICES FOR ADVERTISING PURPOSES, MODELING FOR ADVERTISING OR SALES PROMOTION, ON-LINE ADVERTISING ON A COMPUTER NETWORK, ORGANIZATION OF EXHIBITIONS FOR COMMERCIAL OR ADVERTISING PURPOSES, ORGANIZATION OF TRADE FAIRS FOR COMMERCIAL OR ADVERTISING PURPOSES, RENTAL OF ADVERTISING SPACE (U.S. CLS. 100, 101 AND 102).

FIRST USE 6-1-2011; IN COMMERCE 6-1-2011.

4,017,143. SPIRIT OF AMERICA PRODUCTIONS, LLC,
FRISCO, TX. SN 85-141,526. PUB. 3-15-2011, FILED 9-29-2010.

SPREAD THE SPIRIT

THE MARK CONSISTS OF STANDARD CHARACTERS WITHOUT CLAIM TO ANY PARTICULAR FONT, STYLE, SIZE, OR COLOR.

FOR CHARITABLE SERVICES, NAMELY, ORGANIZING AND CONDUCTING A VOLUNTEER COMMUNITY OUTREACH PROGRAM FOR PROVIDING CLOTHING AND TOILETRIES TO LOWER INCOME PERSONS (U.S. CLS. 100, 101 AND 102).

FIRST USE 11-1-2010; IN COMMERCE 11-1-2010.

CLASS 35—(Continued).

4,017,145. THE PARENTING GROUP, INC., WINTER PARK,
FL. SN 85-143,313. PUB. 3-15-2011, FILED 10-1-2010.

Read.Connect.Grow

THE MARK CONSISTS OF STANDARD CHARACTERS WITHOUT CLAIM TO ANY PARTICULAR FONT, STYLE, SIZE, OR COLOR.

FOR PROMOTING PUBLIC AWARENESS IN THE FIELD OF LITERACY THROUGH AN ANNUAL PROGRAM (U.S. CLS. 100, 101 AND 102).

FIRST USE 10-7-2010; IN COMMERCE 10-7-2010.

4,017,151. ENDURAPACK, LLC, WESTBURY, NY. SN 85-149,315. PUB. 4-5-2011, FILED 10-11-2010.



OWNER OF U.S. REG. NOS. 3,338,759 AND 3,347,136.
NO CLAIM IS MADE TO THE EXCLUSIVE RIGHT TO USE "FLEXIBLE PACKAGING", APART FROM THE MARK AS SHOWN.

THE COLOR(S) ORANGE, BLUE AND GRAY IS/ARE CLAIMED AS A FEATURE OF THE MARK.

THE MARK CONSISTS OF THE WORD "ENDURAPACK" SET IN A STYLIZED FONT WITH THE PHRASE "ENDURA" SET IN ORANGE AND THE PHRASE "PACK" SET IN BLUE. TO THE LEFT OF THE PHRASE "ENDURAPACK" IS A STYLIZED BLUE OUTLINE OF A SHOPPING BAG WITH A CURVED HANDLE. THE OUTLINE OF THE SHOPPING BAG IS FASHIONED WITH DASHED BLUE LINES. BELOW THE WORD "ENDURAPACK" IS THE PHRASE "FLEXIBLE PACKAGING. SOLID RESULTS." IN A GRAY FONT.

FOR WHOLESALE DISTRIBUTORSHIPS FEATURING PAPER BAGS, PLASTIC BAGS AND NONWOVEN BAGS (U.S. CLS. 100, 101 AND 102).

FIRST USE 11-0-2010; IN COMMERCE 11-0-2010.

CLASS 35—(Continued).

4,017,152. ERMENEGILDO ZEGNA CORPORATION, ENGLEWOOD, NJ. SN 85-149,597. PUB. 2-22-2011, FILED 10-11-2010.

ZEGNASPORT

THE MARK CONSISTS OF STANDARD CHARACTERS WITHOUT CLAIM TO ANY PARTICULAR FONT, STYLE, SIZE, OR COLOR.

OWNER OF U.S. REG. NOS. 3,121,451, 3,410,924, AND OTHERS.

FOR RETAIL STORES FEATURING MEN'S CLOTHING AND ACCESSORIES (U.S. CLS. 100, 101 AND 102).
FIRST USE 10-0-2003; IN COMMERCE 10-0-2003.

4,017,159. ACCUCODE, INC., CENTENNIAL, CO. SN 85-151,774. PUB. 3-22-2011, FILED 10-13-2010.

AO: RAPID INVENTORY

THE MARK CONSISTS OF STANDARD CHARACTERS WITHOUT CLAIM TO ANY PARTICULAR FONT, STYLE, SIZE, OR COLOR.

FOR WEB-BASED INVENTORY MANAGEMENT SERVICE (U.S. CLS. 100, 101 AND 102).

FIRST USE 1-1-2011; IN COMMERCE 1-1-2011.

4,017,161. SOCIAL SERVICE COORDINATORS, INC., MIAMI LAKES, FL. SN 85-154,437. PUB. 3-22-2011, FILED 10-17-2010.

CARES

THE MARK CONSISTS OF STANDARD CHARACTERS WITHOUT CLAIM TO ANY PARTICULAR FONT, STYLE, SIZE, OR COLOR.

FOR BUSINESS CONSULTATION SERVICES (U.S. CLS. 100, 101 AND 102).

FIRST USE 4-25-2011; IN COMMERCE 5-28-2011.

CLASS 35—(Continued).

4,017,163. CRAZY WOMAN CONCEPTS, INC., CODY, WY. SN 85-154,972. PUB. 4-26-2011, FILED 10-18-2010.

Crazy About Life

THE MARK CONSISTS OF STANDARD CHARACTERS WITHOUT CLAIM TO ANY PARTICULAR FONT, STYLE, SIZE, OR COLOR.

FOR WHOLESALE DISTRIBUTORSHIPS FEATURING CLOTHING AND GIFT PRODUCTS (U.S. CLS. 100, 101 AND 102).

FIRST USE 7-26-2007; IN COMMERCE 7-26-2007.

4,017,168. JOSEPH D. LAUZEN, WARRENVILLE, IL. SN 85-155,965. PUB. 4-5-2011, FILED 10-19-2010.



NO CLAIM IS MADE TO THE EXCLUSIVE RIGHT TO USE "ACCOUNTING" AND "COMPREHENSIVE ACCOUNTING SOLUTIONS", APART FROM THE MARK AS SHOWN.

THE COLOR(S) BLUE, GRAY AND WHITE IS/ARE CLAIMED AS A FEATURE OF THE MARK.

THE MARK CONSISTS OF WHITE GREEK LETTER LAMBDA IN A BLUE CIRCLE TO THE LEFT OF THE WORD "LAUZEN" IN BLUE AND "ACCOUNTING" IN GRAY OVER A GRAY LINE WITH THE WORDS "COMPREHENSIVE ACCOUNTING SOLUTIONS" IN GRAY LETTERS BELOW.

FOR ACCOUNTANCY SERVICES; ACCOUNTING SERVICES; ADMINISTRATIVE ACCOUNTING; BUSINESS INFORMATION AND ACCOUNTING ADVISORY SERVICES (U.S. CLS. 100, 101 AND 102).

FIRST USE 10-31-2010; IN COMMERCE 12-31-2010.

4,017,177. ENERSAVE US, DBA ENERSAVE INTELLIGENT SAVINGS, SALT LAKE CITY, UT. SN 85-161,752. PUB. 4-12-2011, FILED 10-26-2010.

ENERSAVE INTELLIGENT SAVINGS

THE MARK CONSISTS OF STANDARD CHARACTERS WITHOUT CLAIM TO ANY PARTICULAR FONT, STYLE, SIZE, OR COLOR.

CLASS 35—(Continued).

NO CLAIM IS MADE TO THE EXCLUSIVE RIGHT TO USE "SAVINGS", APART FROM THE MARK AS SHOWN.

FOR CONSULTATION IN THE FIELD OF ENERGY EFFICIENCY, NAMELY, ANALYZING THE RESOURCE CONSUMPTION OF OTHERS AND PROVIDING CUSTOM EQUIPMENT RECOMMENDATIONS RELATED THERETO, AND ANALYZING AND PROVIDING CUSTOM EQUIPMENT RECOMMENDATIONS TO OTHERS FOR POWER FACTOR CORRECTION (U.S. CLS. 100, 101 AND 102).

FIRST USE 12-1-2010; IN COMMERCE 12-1-2010.

4,017,209. LANCE, MARCIE, DBA CREATIVE MARKETING ASSOCIATES, INC., HIGHLAND PARK, IL. SN 85-176,866. PUB. 4-5-2011, FILED 11-15-2010.

CLASS 35—(Continued).

NO CLAIM IS MADE TO THE EXCLUSIVE RIGHT TO USE "PAPER", APART FROM THE MARK AS SHOWN.

FOR ON-LINE RETAIL STORE SERVICES FEATURING PERSONALIZED PRODUCTS, NAMELY, STATIONERY, CALLING CARDS, BUSINESS CARDS, ADDRESS LABELS, MAILING LABELS, WEDDING ANNOUNCEMENTS, WEDDING INVITATIONS, BRIDAL SHOWER INVITATIONS, BIRTH ANNOUNCEMENTS, BIRTHDAY INVITATIONS, GRADUATION ANNOUNCEMENTS, MOVING CARDS, ENVELOPES, FAX COVER SHEETS, RECIPE CARDS, LUGGAGE TAGS, NOTEPADS, NAPKINS, GIFT BAGS, POSTCARDS, HOLIDAY CARDS, LAMPS, WASTE BASKETS, PHOTO FRAMES, PLASTIC TABLEWARE, JEWELRY, CLOTHING, SOAP, STAMPERS, EMBOSSERS AND FURNITURE (U.S. CLS. 100, 101 AND 102).

FIRST USE 1-1-2010; IN COMMERCE 1-1-2010.

4,017,223. API PARTNERS, LLC, BALA CYNWYD, PA. SN 85-185,816. PUB. 4-12-2011, FILED 11-28-2010.

Get Noticed.

THE MARK CONSISTS OF STANDARD CHARACTERS WITHOUT CLAIM TO ANY PARTICULAR FONT, STYLE, SIZE, OR COLOR.

FOR BUSINESS CONSULTING SERVICES RELATING TO THE INTEGRATION OF THE AREAS OF BUSINESS PROCESS TECHNOLOGY, ORGANIZATIONAL LEARNING, CHANGE MANAGEMENT, AND OPERATIONAL SUSTAINABILITY; BUSINESS MANAGEMENT ADVISORY SERVICES RELATING TO FRANCHISING; BUSINESS MANAGEMENT CONSULTING WITH RELATION TO STRATEGY, FINANCING, MARKETING, PRODUCTION, PERSONNEL AND SALE MATTERS FOR COMPANIES INVOLVED WITH THIN FILM AND NANO TECHNOLOGIES AND PLASMA PROCESSES; BUSINESS MANAGEMENT CONSULTING WITH RELATION TO STRATEGY, MARKETING, PRODUCTION, PERSONNEL AND RETAIL SALE MATTERS; BUSINESS MANAGEMENT CONSULTING WITH RELATION TO STRATEGY, MARKETING, SALES, OPERATION, PRODUCT DESIGN PARTICULARLY SPECIALIZING IN THE USE OF ANALYTIC AND STATISTIC MODELS FOR THE UNDERSTANDING AND PREDICTING OF CONSUMERS, BUSINESSES, AND MARKET TRENDS AND ACTIONS (U.S. CLS. 100, 101 AND 102).

FIRST USE 4-1-2011; IN COMMERCE 4-1-2011.

4,017,217. KAREN COLE PAPER LLC, DBA PAPER FANCY, MANAKIN SABOT, VA. SN 85-181,846. PUB. 4-26-2011, FILED 11-20-2010.

paper fancy

THE MARK CONSISTS OF STANDARD CHARACTERS WITHOUT CLAIM TO ANY PARTICULAR FONT, STYLE, SIZE, OR COLOR.

Place.d

THE MARK CONSISTS OF STANDARD CHARACTERS WITHOUT CLAIM TO ANY PARTICULAR FONT, STYLE, SIZE, OR COLOR.

FOR EXECUTIVE SEARCH AND PLACEMENT SERVICES; RECRUITMENT AND PLACEMENT OF PERSONNEL IN THE FIELD OF DIGITAL DESIGN, BUILDING INFORMATION MODELING (BIM), VIRTUAL DESIGN AND CONSTRUCTION (VDC) (U.S. CLS. 100, 101 AND 102).

FIRST USE 12-31-2010; IN COMMERCE 12-31-2010.

4,017,256. FOX FACTORY, INC., WATSONVILLE, CA. SN 85-975,400. PUB. 9-28-2010, FILED 4-27-2010.

WHEN IT COUNTS

THE MARK CONSISTS OF STANDARD CHARACTERS WITHOUT CLAIM TO ANY PARTICULAR FONT, STYLE, SIZE, OR COLOR.

FOR ADVERTISING, MARKETING AND PROMOTIONAL SERVICES FOR DEALERS AND DISTRIBUTORS OF VEHICLE SUSPENSION SYSTEMS INCLUDING SHOCK ABSORBERS FOR VEHICLES (U.S. CLS. 100, 101 AND 102).

FIRST USE 4-15-2010; IN COMMERCE 4-15-2010.

CLASS 36—INSURANCE AND FINANCIAL

CLASS 36—(Continued).

4,016,251. AUGEO AFFINITY INSURANCE SERVICES, INC., ST. PAUL, MN. SN 77-424,937. PUB. 9-22-2009, FILED 3-18-2008.

AUGEO BENEFITS

THE MARK CONSISTS OF STANDARD CHARACTERS WITHOUT CLAIM TO ANY PARTICULAR FONT, STYLE, SIZE, OR COLOR.

NO CLAIM IS MADE TO THE EXCLUSIVE RIGHT TO USE "BENEFITS", APART FROM THE MARK AS SHOWN.

THE ENGLISH TRANSLATION OF "AUGEO" IS "ENHANCE".

FOR INSURANCE SERVICES, NAMELY, PROVISION OF MEDICAL, LIFE, ACCIDENT, DENTAL, VISION, IDENTITY THEFT, PETS, AUTOMOBILE, AND HOME INSURANCE BROKERAGE SERVICES (U.S. CLS. 100, 101 AND 102).

FIRST USE 9-30-2008; IN COMMERCE 9-30-2008.

4,016,254. RICH INVESTMENTS, INC., YORK, PA. SN 77-451,060. PUB. 3-3-2009, FILED 4-17-2008.

Strategically Managing The Environment Of Change

THE MARK CONSISTS OF STANDARD CHARACTERS WITHOUT CLAIM TO ANY PARTICULAR FONT, STYLE, SIZE, OR COLOR.

SEC. 2(F).

FOR FINANCIAL MANAGEMENT SERVICES; FINANCIAL SERVICES, NAMELY, PROVIDING FINANCIAL COUNSELING AND ADVICE CONCERNING MONEY MANAGEMENT, WEALTH MANAGEMENT AND ASSET MANAGEMENT; BROKERAGE SERVICES, NAMELY, PROVIDING BROKERAGE IN THE FIELD OF COMMODITIES, INSURANCE, INVESTMENTS, STOCKS, BONDS, MUTUAL FUNDS, AND SECURITIES; FINANCIAL SERVICES, NAMELY, FINANCIAL PLANNING, BROKERAGE IN THE FIELD OF COMMODITIES, INSURANCE, INVESTMENTS, STOCKS, BONDS, MUTUAL FUNDS, AND SECURITIES, INVESTMENT OF FUNDS FOR OTHERS, INVESTMENT CONSULTATION AND ADVISORY SERVICES, CONSULTATION RELATED TO INVESTMENT STRATEGIES, PORTFOLIO MANAGEMENT, INVESTMENT ADVICE AND CONSULTATION IN THE FIELD OF ASSET ALLOCATION AND ASSET MANAGEMENT (U.S. CLS. 100, 101 AND 102).

FIRST USE 3-18-2008; IN COMMERCE 3-18-2008.

CLASS 36—(Continued).

4,016,501. INTERNATIONAL ACTUARIAL ASSOCIATION / ASSOCIATION ACTUARIELLE INTERNATIONALE, ONTARIO, CANADA. SN 77-894,963. PUB. 10-26-2010, FILED 12-16-2009.

ACTUARIES WITHOUT BORDERS

THE MARK CONSISTS OF STANDARD CHARACTERS WITHOUT CLAIM TO ANY PARTICULAR FONT, STYLE, SIZE, OR COLOR.

NO CLAIM IS MADE TO THE EXCLUSIVE RIGHT TO USE "ACTUARIES", APART FROM THE MARK AS SHOWN.

FOR ACTUARIAL SERVICES; PROVIDING CHARITABLE ACTUARIAL SERVICES IN DEVELOPING COUNTRIES TO ASSIST IN THE DEVELOPMENT OF SOCIAL SECURITY, PENSIONS, INSURANCE, INVESTMENTS, OR HEALTHCARE INFRASTRUCTURES; CONSULTING SERVICES IN THE FIELD OF ACTUARIAL SERVICES (U.S. CLS. 100, 101 AND 102).

FIRST USE 6-0-2010; IN COMMERCE 6-0-2010.

4,016,525. METABANK, SIOUX FALLS, SD. SN 77-904,365. PUB. 4-20-2010, FILED 1-4-2010.

SIMPLEXES

THE MARK CONSISTS OF STANDARD CHARACTERS WITHOUT CLAIM TO ANY PARTICULAR FONT, STYLE, SIZE, OR COLOR.

FOR PREPAID PURCHASE CARD SERVICES, NAMELY, PROCESSING ELECTRONIC PAYMENTS MADE THROUGH PREPAID CARDS (U.S. CLS. 100, 101 AND 102).

FIRST USE 1-0-2011; IN COMMERCE 1-0-2011.

4,016,567. MARKET SHIELD CAPITAL, LLC, NATICK, MA. SN 77-925,876. PUB. 11-16-2010, FILED 2-2-2010.

CPIQ

THE MARK CONSISTS OF STANDARD CHARACTERS WITHOUT CLAIM TO ANY PARTICULAR FONT, STYLE, SIZE, OR COLOR.

FOR EQUITY CAPITAL INVESTMENT; FINANCING AND LOAN SERVICES; INVESTMENT MANAGEMENT; MANAGEMENT OF A CAPITAL INVESTMENT FUND (U.S. CLS. 100, 101 AND 102).

FIRST USE 5-25-2010; IN COMMERCE 7-1-2010.

CLASS 36—(Continued).

4,016,569. CROWN FINANCIAL MINISTRIES, INC., LAWRENCEVILLE, GA. SN 77-926,749. PUB. 5-25-2010, FILED 2-3-2010.

MONEYLIFE

THE MARK CONSISTS OF STANDARD CHARACTERS WITHOUT CLAIM TO ANY PARTICULAR FONT, STYLE, SIZE, OR COLOR.

OWNER OF U.S. REG. NO. 2,611,241.

FOR PROVIDING INFORMATION VIA A GLOBAL COMMUNICATIONS NETWORK FEATURING APPLICATION OF BIBLICAL PRINCIPLES OF FINANCIAL STEWARDSHIP TO PERSONAL FINANCES, CONSUMER CREDIT, PERSONAL BUDGETING, PERSONAL INVESTING, BUSINESS, BUSINESS MANAGEMENT, DEBT MANAGEMENT AND RECOVERY, CHARITABLE GIVING, CAREER PLANNING, LIFE GOALS, ESTATE PLANNING, BUDGETING, INVESTING, BUSINESS, ORGANIZATIONAL DEVELOPMENT, TIME MANAGEMENT, CAREER AND EMPLOYMENT, PHILANTHROPY, CHARITABLE GIVING, CHARITABLE FUNDRAISING, VOCATIONAL ASSESSMENT AND COUNSELING, INDIVIDUAL BEHAVIOR ASSESSMENT, AND INDIVIDUAL PERSONALITY ASSESSMENT; COUNSELING AND CONSULTATION IN THE FIELDS OF CONSUMER CREDIT, DEBT RECOVERY, MONEY AND DEBT MANAGEMENT, BUDGETING, PERSONAL INVESTING, RELIGIOUS AND BIBLICAL MONEY PRINCIPLES, AND DEBT REDUCTION AND CONSOLIDATION (U.S. CLS. 100, 101 AND 102).

FIRST USE 10-1-2010; IN COMMERCE 11-1-2010.

4,016,672. COBALT MORTGAGE, INC., KIRKLAND, WA. SN 77-981,952. PUB. 9-15-2009, FILED 2-10-2007.

COBALT FUNDING

THE MARK CONSISTS OF STANDARD CHARACTERS WITHOUT CLAIM TO ANY PARTICULAR FONT, STYLE, SIZE, OR COLOR.

NO CLAIM IS MADE TO THE EXCLUSIVE RIGHT TO USE "FUNDING", APART FROM THE MARK AS SHOWN. FOR COMMERCIAL LENDING SERVICES; LOAN FINANCING (U.S. CLS. 100, 101 AND 102).

FIRST USE 2-4-2011; IN COMMERCE 2-4-2011.

CLASS 36—(Continued).

4,016,835. CRAWFORD & COMPANY, ATLANTA, GA. SN 85-044,846. PUB. 10-19-2010, FILED 5-21-2010.

BOLD

THE MARK CONSISTS OF STANDARD CHARACTERS WITHOUT CLAIM TO ANY PARTICULAR FONT, STYLE, SIZE, OR COLOR.

FOR PROVIDING INSURANCE RELATED SERVICES RENDERED TO INSURERS, INSURED ENTITIES, AND SELF-INSURED EMPLOYERS SUPPORTING THE ADMINISTRATION AND MANAGEMENT OF WORKERS COMPENSATION CLAIMS AND MITIGATION OF MEDICAL COST DRIVERS THROUGH A CUSTOM PPO NETWORK STRATEGY; PROVIDING AN ON-LINE COMPUTER DATABASE OF WORKERS COMPENSATION INSURANCE INFORMATION TO INSURERS, INSURED ENTITIES, AND SELF-INSURED EMPLOYERS (U.S. CLS. 100, 101 AND 102).

FIRST USE 8-0-2010; IN COMMERCE 8-0-2010.

4,016,843. BRETTON CAPITAL MANAGEMENT LLC, SAN FRANCISCO, CA. SN 85-048,726. PUB. 11-2-2010, FILED 5-26-2010.

Bretton

THE MARK CONSISTS OF STANDARD CHARACTERS WITHOUT CLAIM TO ANY PARTICULAR FONT, STYLE, SIZE, OR COLOR.

THE NAME(S), PORTRAIT(S), AND/OR SIGNATURE(S) SHOWN IN THE MARK DOES NOT IDENTIFY A PARTICULAR LIVING INDIVIDUAL.

FOR FINANCIAL SERVICES, NAMELY, ADVICE RELATING TO INVESTMENTS AND ASSET MANAGEMENT; MUTUAL FUND INVESTMENT (U.S. CLS. 100, 101 AND 102).

FIRST USE 9-30-2010; IN COMMERCE 9-30-2010.

4,016,856. ARAG INSURANCE COMPANY, DES MOINES, IA. SN 85-052,466. PUB. 11-2-2010, FILED 6-2-2010.

DIY DOCS

THE MARK CONSISTS OF STANDARD CHARACTERS WITHOUT CLAIM TO ANY PARTICULAR FONT, STYLE, SIZE, OR COLOR.

CLASS 36—(Continued).

NO CLAIM IS MADE TO THE EXCLUSIVE RIGHT TO USE "DOCS", APART FROM THE MARK AS SHOWN.

FOR ADMINISTRATION OF LEGAL SERVICE PLANS, NAMELY, ADMINISTRATION OF PREPAID LEGAL PLANS DIRECTED AT INDIVIDUALS (U.S. CLS. 100, 101 AND 102).

FIRST USE 3-1-2011; IN COMMERCE 3-1-2011.

4,016,866. CHRYSUS CAPITAL MANAGEMENT, LLC, MEN-
LO PARK, CA. SN 85-054,488. PUB. 11-2-2010, FILED 6-3-
2010.

CHRYSUS

THE MARK CONSISTS OF STANDARD CHARACTERS
WITHOUT CLAIM TO ANY PARTICULAR FONT, STYLE,
SIZE, OR COLOR.

FOR INVESTMENT MANAGEMENT; HEDGE FUND
INVESTMENT SERVICES (U.S. CLS. 100, 101 AND 102).
FIRST USE 2-0-2011; IN COMMERCE 2-0-2011.

4,016,905. ANNCO, INC., NEW YORK, NY. SN 85-065,456.
PUB. 1-18-2011, FILED 6-17-2010.

PERFECT REWARDS

THE MARK CONSISTS OF STANDARD CHARACTERS
WITHOUT CLAIM TO ANY PARTICULAR FONT, STYLE,
SIZE, OR COLOR.

NO CLAIM IS MADE TO THE EXCLUSIVE RIGHT TO
USE "REWARDS", APART FROM THE MARK AS SHOWN.

FOR PROVIDING CASH AND OTHER REBATES FOR
CREDIT CARD USE AS PART OF A CUSTOMER
LOYALTY PROGRAM (U.S. CLS. 100, 101 AND 102).

FIRST USE 10-1-2010; IN COMMERCE 10-1-2010.

CLASS 36—(Continued).

4,016,906. CACHET BANQ, PASADENA, CA. SN 85-065,924.
PUB. 11-16-2010, FILED 6-17-2010.

FlexOBC

THE MARK CONSISTS OF STANDARD CHARACTERS
WITHOUT CLAIM TO ANY PARTICULAR FONT, STYLE,
SIZE, OR COLOR.

FOR BILL PAYMENT SERVICES, NAMELY, CHECK
WRITING SERVICES FOR END USER CLIENTS IN
WHICH CHECKS ARE WRITTEN ON A TRUST AC-
COUNT; BANK CHECK SERVICES, NAMELY, ISSU-
ANCE OF BANK CHECKS ON BEHALF OF OTHERS
(U.S. CLS. 100, 101 AND 102).

FIRST USE 3-31-2011; IN COMMERCE 3-31-2011.

4,016,927. FONVILLE MORISEY REALTY, INC., RALEIGH,
NC. SN 85-068,699. PUB. 11-16-2010, FILED 6-22-2010.

Leading the Triangle and There is a Reason

THE MARK CONSISTS OF STANDARD CHARACTERS
WITHOUT CLAIM TO ANY PARTICULAR FONT, STYLE,
SIZE, OR COLOR.

FOR REAL ESTATE CONSULTATION SERVICES;
REAL ESTATE AGENCIES; REAL ESTATE APPRAISAL;
REAL ESTATE BROKERAGE; REAL ESTATE INVEST-
MENT; REAL ESTATE LISTING; REAL ESTATE MAN-
AGEMENT; REAL ESTATE RENTAL; HOUSING
AGENCIES; INSURANCE AGENCIES; INSURANCE
BROKERAGE; INSURANCE CONSULTATION; INSUR-
ANCE UNDERWRITING; AND MORTGAGE LENDING
(U.S. CLS. 100, 101 AND 102).

FIRST USE 7-31-2010; IN COMMERCE 7-31-2010.

4,016,935. SEARCHLIGHT CAPITAL PARTNERS, L.P., NEW
YORK, NY. SN 85-070,124. PUB. 11-9-2010, FILED 6-23-2010.

SEARCHLIGHT CAPITAL



NO CLAIM IS MADE TO THE EXCLUSIVE RIGHT TO
USE "CAPITAL", APART FROM THE MARK AS SHOWN.

CLASS 36—(Continued).

THE MARK CONSISTS OF THE WORDS "SEARCHLIGHT CAPITAL" WITH A TRIANGLE BENEATH THE WORD "CAPITAL".

FOR FINANCIAL SERVICES, NAMELY, PRIVATE EQUITY FUND INVESTMENT SERVICES; FINANCIAL SERVICES, NAMELY, INVESTMENT OF FUNDS FOR OTHERS, INCLUDING PRIVATE AND PUBLIC EQUITY AND DEBT INVESTMENT SERVICES (U.S. CLS. 100, 101 AND 102).

FIRST USE 2-1-2010; IN COMMERCE 2-1-2010.

4,016,936. SEARCHLIGHT CAPITAL PARTNERS, L.P., NEW YORK, NY. SN 85-070,140. PUB. 11-9-2010, FILED 6-23-2010.



THE MARK CONSISTS OF THE LETTERS "SC" LOCATED ABOVE A TRIANGLE.

FOR FINANCIAL SERVICES, NAMELY, PRIVATE EQUITY FUND INVESTMENT SERVICES; FINANCIAL SERVICES, NAMELY, INVESTMENT OF FUNDS FOR OTHERS, INCLUDING PRIVATE AND PUBLIC EQUITY AND DEBT INVESTMENT SERVICES (U.S. CLS. 100, 101 AND 102).

FIRST USE 2-1-2010; IN COMMERCE 2-1-2010.

4,017,071. AL-KHAWAJA, MAHMOUD, DUBAI, UNITED ARAB EMIR.. SN 85-109,924. PUB. 2-1-2011, FILED 8-18-2010.

CAPINTRO PARTNERS

THE MARK CONSISTS OF STANDARD CHARACTERS WITHOUT CLAIM TO ANY PARTICULAR FONT, STYLE, SIZE, OR COLOR.

NO CLAIM IS MADE TO THE EXCLUSIVE RIGHT TO USE "PARTNERS", APART FROM THE MARK AS SHOWN. FOR FINANCIAL ANALYSIS; BUSINESS LIQUIDATION SERVICES; FINANCIAL CONSULTANCY; FINANCIAL EVALUATION SERVICES FOR INSURANCES, BANKING AND REAL ESTATE; FINANCIAL INFORMATION SERVICES; FINANCIAL MANAGEMENT SERVICES; AND FINANCING SERVICES (U.S. CLS. 100, 101 AND 102).

FIRST USE 6-1-2007; IN COMMERCE 6-1-2007.

CLASS 36—(Continued).

4,017,112. CONSTELLATION ENERGY GROUP, INC., BALTIMORE, MD. SN 85-126,788. PUB. 3-1-2011, FILED 9-10-2010.

E² ENERGY TO EDUCATE

THE MARK CONSISTS OF THE WORDS "E2 ENERGY TO EDUCATE" WITH THE 2 IN SUPERSCRIPT FORMAT.

FOR PROVIDING GRANTS FOR PROJECTS IN THE FIELDS OF ENERGY SCIENCE, ENERGY TECHNOLOGY AND ENERGY EDUCATION (U.S. CLS. 100, 101 AND 102).

FIRST USE 9-16-2010; IN COMMERCE 9-16-2010.

4,017,181. GOLDMAN, SACHS & CO., NEW YORK, NY. SN 85-165,074. PUB. 2-15-2011, FILED 10-29-2010.

YOUR KIDS NEVER STOP GROWING

THE MARK CONSISTS OF STANDARD CHARACTERS WITHOUT CLAIM TO ANY PARTICULAR FONT, STYLE, SIZE, OR COLOR.

FOR FINANCIAL SERVICES, NAMELY, INVESTMENT BROKERAGE AND MANAGEMENT; FINANCING SERVICES; REAL ESTATE INVESTMENT SERVICES; SECURITIES BROKERAGE SERVICES; ELECTRONIC TRADING OF FINANCIAL INSTRUMENTS, COMMODITIES, FOREIGN CURRENCIES, SECURITIES, SHARE OPTIONS, OTHER DERIVATIVE PRODUCTS, HEDGE FUNDS, AND MUTUAL FUNDS; FINANCIAL PORTFOLIO MANAGEMENT SERVICES; INVESTMENT MANAGEMENT AND ADVISORY SERVICES; TRADING OF FINANCIAL SECURITIES; HEDGE FUND/MUTUAL FUNDS INVESTMENT MANAGEMENT SERVICES; FINANCIAL PLANNING SERVICES; MANAGEMENT OF FINANCIAL INVESTMENT ACCOUNTS; PORTFOLIO INVESTMENT ADVISORY SERVICES; BROKERAGE SERVICES IN THE FIELD OF STOCK, BOND, HEDGE FUND, AND MUTUAL FUND INVESTING; ESTABLISHING AND MANAGING STOCK FUNDS, BOND FUNDS, HEDGE FUNDS, AND MUTUAL FUNDS FOR OTHERS; FINANCIAL RESEARCH SERVICES; MICRO FINANCE SERVICES, NAMELY, MAKING SMALL LOANS TO LOW-INCOME PERSONS TO HELP THEM GROW SMALL BUSINESSES; CONSULTING RELATED TO ALL THE FOREGOING SERVICES (U.S. CLS. 100, 101 AND 102).

FIRST USE 5-1-2011; IN COMMERCE 5-1-2011.

CLASS 36—(Continued).

4,017,193. AMERIPRISE FINANCIAL, INC., MINNEAPOLIS, MN. SN 85-169,247. PUB. 4-12-2011, FILED 11-4-2010.



THE MARK CONSISTS OF A RECTANGULAR SHAPED DESIGN BROKEN INTO FOUR SECTIONS TO FORM A WAVE WITH THE WORDING "GROW LIVE SHARE" IN THE TOP THREE SECTIONS AND THE WORDING "GUARANTEES FOR RETIREMENT" IN THE BOTTOM SECTION.

FOR FINANCIAL SERVICES, NAMELY, ISSUANCE AND ADMINISTRATION OF FIXED AND VARIABLE ANNUITIES (U.S. CLS. 100, 101 AND 102).

FIRST USE 1-4-2011; IN COMMERCE 1-4-2011.

4,017,204. AXA EQUITABLE LIFE INSURANCE COMPANY, NEW YORK, NY. SN 85-172,666. PUB. 4-19-2011, FILED 11-9-2010.

RETIREMENT GATEWAY

THE MARK CONSISTS OF STANDARD CHARACTERS WITHOUT CLAIM TO ANY PARTICULAR FONT, STYLE, SIZE, OR COLOR.

NO CLAIM IS MADE TO THE EXCLUSIVE RIGHT TO USE "RETIREMENT", APART FROM THE MARK AS SHOWN.

FOR ANNUITY UNDERWRITING; ISSUANCE AND ADMINISTRATION OF ANNUITIES (U.S. CLS. 100, 101 AND 102).

FIRST USE 3-25-2011; IN COMMERCE 3-25-2011.

4,017,216. EQUITY SCHOLAR, LLC, NEW YORK, NY. SN 85-181,120. PUB. 5-10-2011, FILED 11-19-2010.



NO CLAIM IS MADE TO THE EXCLUSIVE RIGHT TO USE "EQUITY", APART FROM THE MARK AS SHOWN.

CLASS 36—(Continued).

THE MARK CONSISTS OF A CARTOON-LIKE UPPER BODY OF A PERSON WITH A SCHOLAR CAP ON HIS HEAD WITH TASSELS FALLING TO THE RIGHT, WITH 3 ASCENDING BARS, ALONG WITH THE WORDS "EQUITY" AND "SCHOLAR" ADJACENT TO THE IMAGE.

FOR PROVIDING A WEB SITE FEATURING NON-DOWNLOADABLE INSTRUCTIONAL VIDEOS IN THE FIELD OF FINANCE (U.S. CLS. 100, 101 AND 102).

FIRST USE 3-24-2010; IN COMMERCE 2-2-2011.

4,017,232. UNIVEST CORPORATION OF PENNSYLVANIA, SOUDERTON, PA. SN 85-195,348. PUB. 4-19-2011, FILED 12-10-2010.

UNIVEST EAGLET

THE MARK CONSISTS OF STANDARD CHARACTERS WITHOUT CLAIM TO ANY PARTICULAR FONT, STYLE, SIZE, OR COLOR.

OWNER OF U.S. REG. NOS. 2,531,287, 3,791,971, AND OTHERS.

FOR BANKING; BANKING AND FINANCING SERVICES; BANKING SERVICES; HOME BANKING; SAVINGS BANK SERVICES (U.S. CLS. 100, 101 AND 102).

FIRST USE 12-6-2010; IN COMMERCE 2-1-2011.

4,017,241. L'OREAL USA CREATIVE, INC., NEW YORK, NY. SN 85-203,792. PUB. 2-22-2011, FILED 12-22-2010.



OWNER OF U.S. REG. NOS. 1,618,321, 3,018,015, AND OTHERS.

NO CLAIM IS MADE TO THE EXCLUSIVE RIGHT TO USE "SINCE 1851", APART FROM THE MARK AS SHOWN.

THE MARK CONSISTS OF A STYLIZED HEART DESIGN WITH THE WORDS "KIEHL'S SINCE 1851 LIFE RIDE" APPEARING ON A RIBBON-LIKE DESIGN WRAPPED AROUND THE HEART AND FEATURING A FANCIFUL BIRD AND FLOWERS.

FOR CHARITABLE FUND RAISING SERVICES (U.S. CLS. 100, 101 AND 102).

FIRST USE 8-1-2010; IN COMMERCE 8-1-2010.

CLASS 36—(Continued).

4,017,242. MAD SCIENTISTS BREWING PARTNERS LLC, DBA SIXPOINT CRAFT ALES, BROOKLYN, NY. SN 85-207,785. PUB. 4-12-2011, FILED 12-30-2010.

BEER FOR BEASTS

THE MARK CONSISTS OF STANDARD CHARACTERS WITHOUT CLAIM TO ANY PARTICULAR FONT, STYLE, SIZE, OR COLOR.

FOR CHARITABLE SERVICES, NAMELY, ORGANIZING FUNDRAISING SERVICES AND EVENTS TO RAISE FUNDS IN THE FIELD OF ANIMAL RESCUE (U.S. CLS. 100, 101 AND 102).

FIRST USE 3-1-2010; IN COMMERCE 3-1-2010.

4,017,247. UNIVEST CORPORATION OF PENNSYLVANIA, SOUDERTON, PA. SN 85-215,043. PUB. 4-19-2011, FILED 1-11-2011.



THE COLOR(S) BLACK, GRAY, WHITE, YELLOW, BLUE, ORANGE, RED, PINK, BROWN AND LIGHT BROWN IS/ARE CLAIMED AS A FEATURE OF THE MARK.

THE MARK CONSISTS OF A STYLIZED EAGLET WITH A HEAD CONTAINING WHITE AND GRAY SHADING, PIGTAILS THAT ARE FASTENED WITH A PINK RUBBER BAND, OPEN YELLOW BEAK WITH A RED TONGUE, WHITE EYES WITH BLACK PUPILS CONTAINING A SMALL AMOUNT OF BLUE SHADING, WING THAT IS MOSTLY WHITE WITH BROWN SHADING ON THE TIPS OF THE WING, BOTTOM HALF OF THE EAGLET CONTAINS BROWN AND LIGHT BROWN SHADING, TAIL OF THE EAGLET CONTAINS BROWN AND LIGHT BROWN SHADING WITH A WHITE TIP, AND TWO FEET CONTAINING YELLOW AND ORANGE SHADING WITH EACH FOOT HAVING THREE TOES.

FOR BANKING; BANKING SERVICES; HOME BANKING; SAVINGS BANK SERVICES (U.S. CLS. 100, 101 AND 102).

FIRST USE 12-6-2010; IN COMMERCE 2-1-2011.

CLASS 36—(Continued).

4,017,267. MEKIS, THOMAS, WINSTON-SALEM, NC. SN 85-975,475. PUB. 12-14-2010, FILED 4-26-2010.



THE COLOR(S) BLUE IS/ARE CLAIMED AS A FEATURE OF THE MARK.

THE MARK CONSISTS OF A STYLIZED RENDERING OF AN AIRCRAFT FUSELAGE AND TAIL, COMPRISING A CURVED BLUE SHAPE, WITH THREE SMALLER CURVED BLUE SHAPES STACKED ABOVE THE RIGHT SIDE.

FOR AIRCRAFT BROKERAGE SERVICES (U.S. CLS. 100, 101 AND 102).

FIRST USE 11-12-2008; IN COMMERCE 11-12-2008.

CLASS 37—CONSTRUCTION AND REPAIR

4,016,407. SIMONSON, JACK, VILLA PARK, IL. SN 77-836,631. PUB. 3-23-2010, FILED 9-28-2009.



NO CLAIM IS MADE TO THE EXCLUSIVE RIGHT TO USE "PLUMBER", APART FROM THE MARK AS SHOWN.

THE MARK CONSISTS OF A MAN WITH MUSTACHE WEARING A SCOTTISH CAP AND A KILT AND HOLDING A BAGPIPE MADE UP OF PLUMBING PIPES AND PLUNGER, A DOG WEARING A SCOTTISH CAP LOOKING UP AT THE MAN, AND THE WORDING "THE SCOTTISH PLUMBER "THE PIPES ARE CALLING..." APPEARING ABOVE THE DOG AND TO THE RIGHT OF THE MAN.

FOR PLUMBING CONTRACTOR SERVICES; PLUMBING SERVICES (U.S. CLS. 100, 103 AND 106).

FIRST USE 7-15-2009; IN COMMERCE 7-15-2009.

CLASS 37—(Continued).

4,016,444. UV2U TECHNOLOGIES, LLC, BURLINGTON, WI. SN 77-877,098. PUB. 4-20-2010, FILED 11-20-2009.

UV2U TECHNOLOGIES

THE MARK CONSISTS OF STANDARD CHARACTERS WITHOUT CLAIM TO ANY PARTICULAR FONT, STYLE, SIZE, OR COLOR.

NO CLAIM IS MADE TO THE EXCLUSIVE RIGHT TO USE "TECHNOLOGIES", APART FROM THE MARK AS SHOWN.

FOR DISINFECTING (U.S. CLS. 100, 103 AND 106). FIRST USE 12-0-2009; IN COMMERCE 12-0-2009.

4,016,792. GREEN SHERRY, CARROLLTON, TX. SN 85-033,877. PUB. 4-19-2011, FILED 5-10-2010.

GUARANTEED RIGHT, DAY OR NIGHT!

THE MARK CONSISTS OF STANDARD CHARACTERS WITHOUT CLAIM TO ANY PARTICULAR FONT, STYLE, SIZE, OR COLOR.

FOR HVAC SERVICES, NAMELY, AIR CONDITIONING AND HEATING REPAIR, INSTALLATION, MAINTENANCE AND REPLACEMENT FOR HOMEOWNERS AND SMALL BUSINESSES (U.S. CLS. 100, 103 AND 106). FIRST USE 6-1-2010; IN COMMERCE 6-1-2010.

4,016,793. GREEN SHERRY, CARROLLTON, TX. SN 85-033,881. PUB. 3-8-2011, FILED 5-10-2010.

RIGHTDAYORNIGHT.COM

THE MARK CONSISTS OF STANDARD CHARACTERS WITHOUT CLAIM TO ANY PARTICULAR FONT, STYLE, SIZE, OR COLOR.

FOR HVAC SERVICES, NAMELY, AIR CONDITIONING AND HEATING REPAIR, INSTALLATION, MAINTENANCE AND REPLACEMENT FOR HOMEOWNERS AND SMALL BUSINESSES (U.S. CLS. 100, 103 AND 106). FIRST USE 6-1-2010; IN COMMERCE 6-1-2010.

CLASS 37—(Continued).

4,016,975. NRG ENERGY, INC., PRINCETON, NJ. SN 85-080,963. PUB. 12-28-2010, FILED 7-9-2010.

NRG

THE MARK CONSISTS OF STANDARD CHARACTERS WITHOUT CLAIM TO ANY PARTICULAR FONT, STYLE, SIZE, OR COLOR.

OWNER OF U.S. REG. NOS. 2,182,531, 3,865,568, AND OTHERS.

FOR CONSTRUCTION PLANNING AND CUSTOM CONSTRUCTION OF ELECTRIC POWER PLANTS, NAMELY, WIND, SOLAR, NUCLEAR, COAL FIRED POWER PLANTS AND PLANTS USING BIO-MASS FUELS; INSTALLATION AND MAINTENANCE OF POWER PLANTS, NAMELY, WIND, SOLAR, NUCLEAR, COAL FIRED POWER PLANTS AND PLANTS USING BIO-MASS FUELS (U.S. CLS. 100, 103 AND 106). FIRST USE 3-25-2004; IN COMMERCE 3-25-2004.

4,017,003. LA ROCCA, LANCE BRUNO, NOVATO, CA. SN 85-086,841. PUB. 12-21-2010, FILED 7-16-2010.

Nobody cleans better for less!

THE MARK CONSISTS OF STANDARD CHARACTERS WITHOUT CLAIM TO ANY PARTICULAR FONT, STYLE, SIZE, OR COLOR.

FOR RESIDENTIAL, COMMERCIAL AND OR INDUSTRIAL MAID CLEANING SERVICES (U.S. CLS. 100, 103 AND 106).

FIRST USE 3-1-2003; IN COMMERCE 3-1-2003.

4,017,004. LA ROCCA, LANCE BRUNO, NOVATO, CA. SN 85-086,879. PUB. 1-4-2011, FILED 7-16-2010.



NO CLAIM IS MADE TO THE EXCLUSIVE RIGHT TO USE "JANITORIAL SERVICE", APART FROM THE MARK AS SHOWN.

CLASS 37—(Continued).

THE MARK CONSISTS OF A PICTURE OF A COMMERCIAL/INDUSTRIAL BUILDING WITH A LARGE STAR ON THE TOP RIGHT PORTION OF THE ROOF. WITH THE TRADEMARK NAME: "LA ROCCA'S JANITORIAL SERVICE", JUST BELOW THE BUILDING.

FOR COMMERCIAL AND INDUSTRIAL JANITORIAL CLEANING SERVICES (U.S. CLS. 100, 103 AND 106).
FIRST USE 9-16-2010; IN COMMERCE 9-16-2010.

4,017,021. DARLING INTERNATIONAL INC., IRVING, TX.
SN 85-092,832. PUB. 1-11-2011, FILED 7-26-2010.



NO CLAIM IS MADE TO THE EXCLUSIVE RIGHT TO USE "TRAP SERVICES", APART FROM THE MARK AS SHOWN.

THE MARK CONSISTS OF THE WORDS "TRAP SERVICES" WITH A TRIANGLE DESIGN ELEMENT INSERTED IN THE PLACE OF THE LETTER "A".

FOR CLEANING OF GREASE TRAPS; COLLECTION AND REMOVAL OF GREASE FROM FOOD SERVICE ESTABLISHMENTS FOR THE PURPOSES OF RECYCLING AND DISPOSAL (U.S. CLS. 100, 103 AND 106).
FIRST USE 10-31-2010; IN COMMERCE 10-31-2010.

4,017,023. DARLING INTERNATIONAL INC., IRVING, TX.
SN 85-092,847. PUB. 1-11-2011, FILED 7-26-2010.



NO CLAIM IS MADE TO THE EXCLUSIVE RIGHT TO USE "COOKING OIL REMOVAL", APART FROM THE MARK AS SHOWN.

CLASS 37—(Continued).

THE MARK CONSISTS OF THE WORDS "COR COOKING OIL REMOVAL" WITH A TRIANGLE DESIGN ELEMENT INSERTED IN THE PLACE OF THE LETTER "O" IN THE WORD "COR".

FOR COLLECTION AND REMOVAL OF COOKING OIL FROM FOOD SERVICE ESTABLISHMENTS FOR THE PURPOSES OF RECYCLING AND DISPOSAL (U.S. CLS. 100, 103 AND 106).
FIRST USE 10-31-2010; IN COMMERCE 10-31-2010.

4,017,186. NRG ENERGY, INC., PRINCETON, NJ. SN 85-166,969. PUB. 3-8-2011, FILED 11-2-2010.



THE COLOR(S) GREEN AND BLUE IS/ARE CLAIMED AS A FEATURE OF THE MARK.

THE MARK CONSISTS OF THE SMALL LETTER "E" AND CAPITAL LETTER "V" IN GREEN WITH THE SMALL LETTERS "GO" IN BLUE FOLLOWED BY A DESIGN OF A BIRD ALONG WITH THE WORDS "BE FREE" IN SMALLER FONT AND IN GREEN.

FOR A NETWORK OF ELECTRIC VEHICLE CHARGING STATIONS; BATTERY CHARGING SERVICES FOR ELECTRIC VEHICLES (U.S. CLS. 100, 103 AND 106).
FIRST USE 11-18-2010; IN COMMERCE 11-18-2010.

CLASS 38—COMMUNICATION

4,016,201. VENKAT RAMASWAMY, FALLS CHURCH, VA.
SN 77-292,285. PUB. 8-31-2010, FILED 9-29-2007.

Seesay

THE MARK CONSISTS OF STANDARD CHARACTERS WITHOUT CLAIM TO ANY PARTICULAR FONT, STYLE, SIZE, OR COLOR.

FOR DELIVERY OF MESSAGES BY ELECTRONIC TRANSMISSION; ELECTRONIC MESSAGE SENDING; ELECTRONIC MESSAGE TRANSMISSION; ELECTRONIC MESSAGING SYSTEM, NAMELY, ELECTRONIC QUEUING SERVICES; ELECTRONIC STORE-AND-FORWARD MESSAGING; ELECTRONIC TRANSMISSION OF MESSAGES AND DATA; PROVIDING ON-LINE CHAT ROOMS AND ELECTRONIC BULLETIN BOARDS FOR TRANSMISSION OF MESSAGES AMONG USERS IN THE FIELD OF GENERAL INTEREST (U.S. CLS. 100, 101 AND 104).
FIRST USE 2-3-2007; IN COMMERCE 5-1-2008.

CLASS 38—(Continued).

4,016,434. MC21 CORPORATION, CAGUAS, PUERTO RICO. SN 77-870,121. PUB. 4-27-2010, FILED 11-11-2009.



NO CLAIM IS MADE TO THE EXCLUSIVE RIGHT TO USE "TECHNOLOGIES", APART FROM THE MARK AS SHOWN.

THE MARK CONSISTS OF A STYLIZED REPRESENTATION OF A GLOBE WITH LINES THAT INTERCEPT AND DOTS THAT CONNECT THE LINES AND FORM A TRIANGLE, OVER THE WORDS "MEDHEALTH TECHNOLOGIES".

FOR ELECTRONIC TRANSMISSION OF MESSAGES AND DATA REGARDING PRESCRIPTIONS, ALTERNATIVE MEDICAL THERAPIES, PATIENT RECORDS AND OTHER MEDICAL INFORMATION (U.S. CLS. 100, 101 AND 104).

FIRST USE 4-30-2010; IN COMMERCE 4-30-2010.

4,016,570. CROWN FINANCIAL MINISTRIES, INC., LAWRENCEVILLE, GA. SN 77-926,764. PUB. 5-25-2010, FILED 2-3-2010.

MONEYLIFE

THE MARK CONSISTS OF STANDARD CHARACTERS WITHOUT CLAIM TO ANY PARTICULAR FONT, STYLE, SIZE, OR COLOR.

OWNER OF U.S. REG. NO. 2,611,241.

FOR STREAMING OF AUDIO, VISUAL, AND AUDIO-VISUAL MATERIAL VIA A GLOBAL COMPUTER NETWORK FEATURING APPLICATION OF BIBLICAL PRINCIPLES OF FINANCIAL STEWARDSHIP TO PERSONAL FINANCES, CONSUMER CREDIT, PERSONAL BUDGETING, PERSONAL INVESTING, BUSINESS, BUSINESS MANAGEMENT, DEBT MANAGEMENT AND RECOVERY, CHARITABLE GIVING, CAREER PLANNING, LIFE GOALS, ESTATE PLANNING, BUDGETING, INVESTING, BUSINESS, ORGANIZATIONAL DEVELOPMENT, TIME MANAGEMENT, CAREER AND EMPLOYMENT, PHILANTHROPY, CHARITABLE GIVING, CHARITABLE FUNDRAISING, VOCATIONAL ASSESSMENT AND COUNSELING, INDIVIDUAL BEHAVIOR ASSESSMENT, AND INDIVIDUAL PERSONALITY ASSESSMENT (U.S. CLS. 100, 101 AND 104).

FIRST USE 10-1-2010; IN COMMERCE 11-1-2010.

CLASS 38—(Continued).

4,016,764. TRACFONE WIRELESS, INC., MIAMI, FL. SN 85-018,422. PUB. 9-21-2010, FILED 4-20-2010.

THE LONGER YOU STAY THE
LESS YOU PAY

THE MARK CONSISTS OF STANDARD CHARACTERS WITHOUT CLAIM TO ANY PARTICULAR FONT, STYLE, SIZE, OR COLOR.

FOR CELLULAR TELEPHONE COMMUNICATIONS SERVICES; CELLULAR TELEPHONE TELECOMMUNICATIONS SERVICES PROVIDED VIA PREPAID AIR TIME CELLULAR TELEPHONES AND PREPAID AIR TIME CELLULAR TELEPHONE CALLING CARD SERVICES (U.S. CLS. 100, 101 AND 104).

FIRST USE 5-27-2011; IN COMMERCE 5-27-2011.

CLASS 39—TRANSPORTATION AND STORAGE

4,016,210. BRYANT, ROY K., SAN DIEGO, CA. AND ALFREDO N. VEJAR, SAN DIEGO, CA. SN 77-320,759. PUB. 11-9-2010, FILED 11-3-2007.

TWO BIT TOW "WE'LL GET YOU
HOME"

THE MARK CONSISTS OF STANDARD CHARACTERS WITHOUT CLAIM TO ANY PARTICULAR FONT, STYLE, SIZE, OR COLOR.

NO CLAIM IS MADE TO THE EXCLUSIVE RIGHT TO USE "TOW", APART FROM THE MARK AS SHOWN.

FOR EMERGENCY AUTO OR TRUCK TOWING; EMERGENCY AUTOMOBILE TOWING; EMERGENCY TRUCK TOWING; VEHICLE TOWING (U.S. CLS. 100 AND 105).

FIRST USE 7-1-2009; IN COMMERCE 7-1-2009.

4,016,341. PATTERN ENERGY GROUP LP, SAN FRANCISCO, CA. SN 77-748,259. PUB. 4-20-2010, FILED 5-29-2009.

PATTERN ENERGY

THE MARK CONSISTS OF STANDARD CHARACTERS WITHOUT CLAIM TO ANY PARTICULAR FONT, STYLE, SIZE, OR COLOR.

NO CLAIM IS MADE TO THE EXCLUSIVE RIGHT TO USE "ENERGY", APART FROM THE MARK AS SHOWN.

FOR TRANSMISSION OF ELECTRICITY ACROSS POWER LINES; PROVIDING INFORMATION IN THE FIELD OF TRANSMISSION OF ENVIRONMENTALLY-PREFERABLE ENERGY (U.S. CLS. 100 AND 105).

FIRST USE 3-0-2010; IN COMMERCE 3-0-2010.

CLASS 39—(Continued).

4,016,454. UNIGROUP, INC., FENTON, MO. SN 77-880,729. PUB. 5-18-2010, FILED 11-25-2009.



NO CLAIM IS MADE TO THE EXCLUSIVE RIGHT TO USE "MOVE INCLUDED" AND "PURCHASE MOVE", APART FROM THE MARK AS SHOWN.

THE MARK CONSISTS OF THE PHRASE "MOVE INCLUDED", WHICH APPEARS OVER THE PHRASE "PURCHASE MOVE LIVE". THERE IS A CARROT OVER THE TERM "IN", WHICH APPEARS IN A STYLISTICALLY DIFFERENT FONT FROM THE OTHER TERMS. THERE ARE DOTS BETWEEN THE TERMS "PURCHASE", "MOVE", AND "LIVE".

FOR TRANSPORTATION AND STORAGE OF GOODS (U.S. CLS. 100 AND 105).

FIRST USE 6-2-2010; IN COMMERCE 6-2-2010.

CLASS 39—(Continued).

4,016,738. SUPERSHUTTLE INTERNATIONAL, INC., SCOTTSDALE, AZ. SN 85-007,817. PUB. 9-7-2010, FILED 4-6-2010.



THE MARK CONSISTS OF A LEAF DESIGN WITH THE WORDS "RIDE BLUE" TO THE LEFT OF THE DESIGN AND THE WORDS "GO GREEN" TO THE RIGHT OF THE DESIGN.

FOR TRANSPORTATION SERVICES, NAMELY, AIRPORT GROUND, CHARTER, AND DOOR-TO-DOOR TRANSPORTATION SERVICES OF PASSENGERS BY MOTOR VEHICLES, NAMELY, VANS AND MINIBUSES, NONE OF THE FOREGOING TO INCLUDE VEHICLE RENTAL OR LEASING SERVICES (U.S. CLS. 100 AND 105).

FIRST USE 4-6-2010; IN COMMERCE 4-6-2010.

4,016,787. HOMEDIRECT, INC., HILLSIDE, IL. SN 85-030,844. PUB. 10-19-2010, FILED 5-5-2010.



4,016,600. FUNVENTURES TRAVEL, LLC., INVER GROVE HEIGHTS, MN. SN 77-941,606. PUB. 7-20-2010, FILED 2-22-2010.

Travel with a Heart

THE MARK CONSISTS OF STANDARD CHARACTERS WITHOUT CLAIM TO ANY PARTICULAR FONT, STYLE, SIZE, OR COLOR.

NO CLAIM IS MADE TO THE EXCLUSIVE RIGHT TO USE "TRAVEL", APART FROM THE MARK AS SHOWN.

FOR TRAVEL AGENCY SERVICES, NAMELY, MAKING RESERVATIONS AND BOOKINGS FOR TRANSPORTATION; TRAVEL, EXCURSION AND CRUISE ARRANGEMENT (U.S. CLS. 100 AND 105).

FIRST USE 1-0-2009; IN COMMERCE 1-0-2009.

OWNER OF U.S. REG. NOS. 2,913,669, 3,039,509, AND OTHERS.

NO CLAIM IS MADE TO THE EXCLUSIVE RIGHT TO USE "HOMEDIRECT EXPRESS", APART FROM THE MARK AS SHOWN.

THE MARK CONSISTS OF THE WORDING "HOMEDIRECT EXPRESS BRINGING IT HOME. FASTER. GUARANTEED." THE WORD "EXPRESS" APPEARS INSIDE A SHADED RECTANGLE DESIGN WITH TWO ARROWS POINTING UPWARD FROM IT. THE LEFT ARROW HAS A CHIMNEY ON THE RIGHT SIDE OF THE TOP OF THE ARROW. THE WORDING AND DESIGN ELEMENTS ALL APPEAR WITHIN A RECTANGULAR BORDER.

FOR TRANSPORT AND DELIVERY OF GOODS; TRANSPORTATION AND DELIVERY SERVICES BY AIR, ROAD, RAIL AND SEA (U.S. CLS. 100 AND 105).

FIRST USE 3-2-2009; IN COMMERCE 3-2-2009.

CLASS 39—(Continued).

4,016,850. YOUNG IMPACT LLC, CLARKS SUMMIT, PA. SN 85-049,921. PUB. 10-26-2010, FILED 5-27-2010.

ENTREPRETOUR

THE MARK CONSISTS OF STANDARD CHARACTERS WITHOUT CLAIM TO ANY PARTICULAR FONT, STYLE, SIZE, OR COLOR.

FOR COORDINATING TRAVEL ARRANGEMENTS FOR INDIVIDUALS AND FOR GROUPS; ARRANGING TRAVEL TOURS; ORGANIZATION OF TRAVEL; TRAVEL AND TOUR INFORMATION SERVICE (U.S. CLS. 100 AND 105).

FIRST USE 6-20-2011; IN COMMERCE 6-20-2011.

4,017,121. MERCY MEDICAL AIRLIFT, VIRGINIA BEACH, VA. SN 85-130,517. PUB. 3-1-2011, FILED 9-15-2010.

AIRLINE ANGELS FOR LIFE

THE MARK CONSISTS OF STANDARD CHARACTERS WITHOUT CLAIM TO ANY PARTICULAR FONT, STYLE, SIZE, OR COLOR.

NO CLAIM IS MADE TO THE EXCLUSIVE RIGHT TO USE "AIRLINE", APART FROM THE MARK AS SHOWN.

FOR CHARITABLE SERVICES, NAMELY, PROVIDING AIRLINE TRANSPORTATION TO PATIENTS TO RECEIVE MEDICAL CARE (U.S. CLS. 100 AND 105).

FIRST USE 2-1-2011; IN COMMERCE 2-1-2011.

CLASS 40—MATERIAL TREATMENT

4,016,243. HIGH IMPACT TECHNOLOGY, TIGARD, OR. SN 77-382,141. PUB. 5-6-2008, FILED 1-28-2008.

BattleSeal

THE MARK CONSISTS OF STANDARD CHARACTERS WITHOUT CLAIM TO ANY PARTICULAR FONT, STYLE, SIZE, OR COLOR.

FOR APPLYING PROTECTIVE COATINGS TO METAL, PLASTICS AND COMPOSITE MATERIAL FOR MITIGATION OF LIQUID LOSS (U.S. CLS. 100, 103 AND 106).

FIRST USE 6-24-2011; IN COMMERCE 6-24-2011.

CLASS 40—(Continued).

4,016,641. ROBBIE MANUFACTURING, INC., LENEXA, KS. SN 77-957,525. PUB. 8-3-2010, FILED 3-12-2010.

FLEXTTEXT

THE MARK CONSISTS OF STANDARD CHARACTERS WITHOUT CLAIM TO ANY PARTICULAR FONT, STYLE, SIZE, OR COLOR.

FOR PRINTING OF ADVERTISING MATTER ON PLASTIC FILM AND PACKAGING (U.S. CLS. 100, 103 AND 106).

FIRST USE 1-21-2011; IN COMMERCE 1-21-2011.

4,016,642. ROBBIE MANUFACTURING, INC., LENEXA, KS. SN 77-957,539. PUB. 11-2-2010, FILED 3-12-2010.

T2 - TRACE N' TALLY

THE MARK CONSISTS OF STANDARD CHARACTERS WITHOUT CLAIM TO ANY PARTICULAR FONT, STYLE, SIZE, OR COLOR.

FOR PRINTING OF SEQUENTIAL NUMBERING ON PLASTIC FILM AND PACKAGING FOR OTHERS (U.S. CLS. 100, 103 AND 106).

FIRST USE 1-21-2011; IN COMMERCE 1-21-2011.

4,016,699. AMERICAN BLUE RIBBON HOLDINGS, LLC, DENVER, CO. SN 77-982,201. PUB. 10-19-2010, FILED 11-23-2009.

LEGENDARY BAKING

THE MARK CONSISTS OF STANDARD CHARACTERS WITHOUT CLAIM TO ANY PARTICULAR FONT, STYLE, SIZE, OR COLOR.

FOR PROVISION OF BAKERY PRODUCTS FOR RESTAURANTS AND GROCERY STORES, NAMELY, THE MANUFACTURE OF BAKERY PRODUCTS TO THE ORDER AND SPECIFICATION OF RESTAURANTS AND GROCERY STORES; BAKERY SERVICES, NAMELY, THE MANUFACTURE OF BAKERY PRODUCTS TO ORDER AND/OR SPECIFICATION OF OTHERS; PRIVATE LABEL BAKING SERVICES (U.S. CLS. 100, 103 AND 106).

FIRST USE 6-6-2010; IN COMMERCE 6-6-2010.

CLASS 40—(Continued).

4,016,957. PENDERGRAFT, GENE, MARICOPA, AZ. AND PENDERGRAFT, LEIGH, MARICOPA, AZ. AND PENDERGRAFT, MARC, MARICOPA, AZ. SN 85-075,809. PUB. 11-30-2010, FILED 7-1-2010.

CLASS 41—(Continued).

4,016,209. THE VANDERBILT UNIVERSITY, NASHVILLE, TN. SN 77-319,565. PUB. 3-18-2008, FILED 11-1-2007.

RAISIN RIDERS RULE

THE MARK CONSISTS OF STANDARD CHARACTERS WITHOUT CLAIM TO ANY PARTICULAR FONT, STYLE, SIZE, OR COLOR.
 FOR CUSTOM IMPRINTING OF CLOTHING, DECALS, STICKERS, AND FLAGS (U.S. CLS. 100, 103 AND 106).
 FIRST USE 1-22-2011; IN COMMERCE 2-22-2011.

VANDERBILT HEALTH

THE MARK CONSISTS OF STANDARD CHARACTERS WITHOUT CLAIM TO ANY PARTICULAR FONT, STYLE, SIZE, OR COLOR.
 OWNER OF U.S. REG. NOS. 1,642,042, 2,778,959, AND OTHERS.
 NO CLAIM IS MADE TO THE EXCLUSIVE RIGHT TO USE "HEALTH", APART FROM THE MARK AS SHOWN.
 FOR EDUCATIONAL SERVICES, NAMELY, CONDUCTING CLASSES, CONFERENCES, COURSES, LECTURES, MEETINGS, SEMINARS, SYMPOSIUMS, TRAINING PROGRAMS AND WORKSHOPS, IN THE FIELDS OF DISEASES, DISEASE PREVENTION, HEALTH CARE, MEDICINE, MEDICAL RESEARCH AND MEDICAL SERVICES, AND DISTRIBUTING COURSE MATERIALS IN CONNECTION THEREWITH (U.S. CLS. 100, 101 AND 107).
 FIRST USE 9-8-2009; IN COMMERCE 9-8-2009.

4,017,048. WASTE MANAGEMENT, INC., HOUSTON, TX. SN 85-103,590. PUB. 1-11-2011, FILED 8-9-2010.

RECYCLE-2-SAVE

THE MARK CONSISTS OF STANDARD CHARACTERS WITHOUT CLAIM TO ANY PARTICULAR FONT, STYLE, SIZE, OR COLOR.
 NO CLAIM IS MADE TO THE EXCLUSIVE RIGHT TO USE "RECYCLE", APART FROM THE MARK AS SHOWN.
 FOR RECYCLING AND WASTE TREATMENT SERVICES (U.S. CLS. 100, 103 AND 106).
 FIRST USE 6-21-2011; IN COMMERCE 6-21-2011.

4,016,226. ID ANALYTICS, INC., SAN DIEGO, CA. SN 77-347,242. PUB. 4-15-2008, FILED 12-7-2007.

4,017,088. MCKISSACK III, JOHN B., VIDOR, TX. SN 85-115,494. PUB. 2-8-2011, FILED 8-25-2010.

TEXAS BIG BEER BREWERY

THE MARK CONSISTS OF STANDARD CHARACTERS WITHOUT CLAIM TO ANY PARTICULAR FONT, STYLE, SIZE, OR COLOR.
 NO CLAIM IS MADE TO THE EXCLUSIVE RIGHT TO USE "TEXAS" OR "BEER BREWERY", APART FROM THE MARK AS SHOWN.
 FOR BREWERY SERVICES (U.S. CLS. 100, 103 AND 106).
 FIRST USE 9-1-2010; IN COMMERCE 4-1-2011.



CLASS 41—EDUCATION AND ENTERTAINMENT

FOR ARRANGING AND CONDUCTING SEMINARS AND CONFERENCES IN THE FIELD OF IDENTITY SECURITY (U.S. CLS. 100, 101 AND 107).
 FIRST USE 2-24-2011; IN COMMERCE 2-24-2011.

CLASS 41—(Continued).

4,016,250. THE MARINE MAMMAL CENTER, SAUSALITO, CA. SN 77-424,350. PUB. 4-28-2009, FILED 3-17-2008.



The Marine
Mammal Center

OWNER OF U.S. REG. NOS. 1,722,622, 2,723,948, AND 2,799,855.

NO CLAIM IS MADE TO THE EXCLUSIVE RIGHT TO USE "CENTER", APART FROM THE MARK AS SHOWN.

THE MARK CONSISTS OF A SEAL IN THE SHAPE OF A TEARDROP, ALONG WITH THE WORDING "THE MARINE MAMMAL CENTER".

SEC. 2(F) AS TO "THE MARINE MAMMAL CENTER".

FOR EDUCATIONAL SERVICES, NAMELY, CONDUCTING CLASSES, WORKSHOPS, SEMINARS AND CONFERENCES IN THE FIELD OF MARINE MAMMALS AND THEIR ENVIRONMENT, RESCUE, REHABILITATION AND RELEASE BACK TO THE WILD (U.S. CLS. 100, 101 AND 107).

FIRST USE 4-30-2011; IN COMMERCE 4-30-2011.

4,016,253. THE CARTOON NETWORK, INC., ATLANTA, GA. SN 77-444,134. PUB. 8-26-2008, FILED 4-9-2008.

CHECK IT OUT!

THE MARK CONSISTS OF STANDARD CHARACTERS WITHOUT CLAIM TO ANY PARTICULAR FONT, STYLE, SIZE, OR COLOR.

FOR ENTERTAINMENT SERVICES, NAMELY, A MULTIMEDIA PROGRAM SERIES FEATURING COMEDY, ACTION AND ADVENTURE DISTRIBUTED VIA VARIOUS PLATFORMS ACROSS MULTIPLE FORMS OF TRANSMISSION MEDIA (U.S. CLS. 100, 101 AND 107).

FIRST USE 5-16-2010; IN COMMERCE 5-16-2010.

CLASS 41—(Continued).

4,016,262. JOHNSON, STEVEN, GLADWIN, MI. SN 77-473,003. PUB. 10-14-2008, FILED 5-13-2008.



THE MARK CONSISTS OF A BAT ZOOMING DOWNWARD OUT OF THE SKY WITH FLAMES COMING OFF HIS WINGS.

FOR ENTERTAINMENT SERVICES, NAMELY, PROVIDING A WEB SITE FEATURING MUSICAL PERFORMANCES, MUSICAL VIDEOS, RELATED FILM CLIPS, PHOTOGRAPHS, AND OTHER MULTIMEDIA MATERIALS (U.S. CLS. 100, 101 AND 107).

FIRST USE 2-15-2008; IN COMMERCE 2-15-2009.

4,016,290. MBOGORI, ERIC, ATLANTA, GA. SN 77-623,656. PUB. 4-7-2009, FILED 12-1-2008.

GAMBYT

THE MARK CONSISTS OF STANDARD CHARACTERS WITHOUT CLAIM TO ANY PARTICULAR FONT, STYLE, SIZE, OR COLOR.

FOR ENTERTAINMENT SERVICES IN THE NATURE OF LIVE MUSICAL PERFORMANCES; ENTERTAINMENT SERVICES, NAMELY, LIVE, TELEVISED AND MOVIE APPEARANCES BY A PROFESSIONAL ENTERTAINER; ENTERTAINMENT, NAMELY, LIVE MUSIC CONCERTS (U.S. CLS. 100, 101 AND 107).

FIRST USE 3-13-2011; IN COMMERCE 4-22-2011.

4,016,308. EWILLOW.COM, LLC, JUPITER, FL. SN 77-684,827. PUB. 7-27-2010, FILED 3-5-2009.



NO CLAIM IS MADE TO THE EXCLUSIVE RIGHT TO USE "CREATE SELL BUY SHARE", APART FROM THE MARK AS SHOWN.

THE COLOR(S) BROWN AND GREEN IS/ARE CLAIMED AS A FEATURE OF THE MARK.

CLASS 41—(Continued).

THE MARK CONSISTS OF THE STYLIZED WORDING "EWILLOW.COM" IN BROWN WITH THE FOLIAGE OUTLINE OF A TREE IN GREEN DIRECTLY ABOVE THE LETTERS "LL" IN "WILLOW", WITH THE LETTERS "LL" FORMING THE STYLIZED TRUNK OF THE TREE, AND THE WORDING "CREATE SELL BUY SHARE" IN GREEN, LOWER-CASE ARIAL FONT, DOUBLE-SPACED LETTERS, SEPARATED BY CENTERLINE DOTS IN GREEN.

FOR PROVIDING NEWSLETTERS IN THE FIELD OF PAPER CRAFTING VIA E-MAIL; PROVIDING ON-LINE E-ZINES IN THE FIELD OF PAPER CRAFTING (U.S. CLS. 100, 101 AND 107).

FIRST USE 9-1-2009; IN COMMERCE 9-1-2009.

CLASS 41—(Continued).

4,016,317. COSSIN, DAVID M, DBA WONDERGROUND, NEW YORK CITY, NY. SN 77-701,575. PUB. 7-28-2009, FILED 3-28-2009.

Wonderground

THE MARK CONSISTS OF STANDARD CHARACTERS WITHOUT CLAIM TO ANY PARTICULAR FONT, STYLE, SIZE, OR COLOR.

FOR MUSIC, ART, DANCE, THEATER AND PUPPETRY CLASSES FOR CHILDREN (U.S. CLS. 100, 101 AND 107).

FIRST USE 7-20-2010; IN COMMERCE 7-20-2010.

4,016,310. INTELLIGENT MARKETING SOLUTIONS, INC., PURCHASE, NY. SN 77-686,231. PUB. 12-1-2009, FILED 3-9-2009.



4,016,331. SELF AWARENESS TRAININGS LLC, SYLMAR, CA. SN 77-732,994. PUB. 8-24-2010, FILED 5-8-2009.

Sporting The Right Attitude

THE MARK CONSISTS OF STANDARD CHARACTERS WITHOUT CLAIM TO ANY PARTICULAR FONT, STYLE, SIZE, OR COLOR.

FOR EDUCATIONAL WORKSHOPS AND TRAINING PROGRAMS IN THE FIELD OF SELF HELP (U.S. CLS. 100, 101 AND 107).

FIRST USE 11-1-2009; IN COMMERCE 11-1-2009.

4,016,355. EDUCATIONAL TESTING SERVICE, AKA ETS, PRINCETON, NJ. SN 77-760,088. PUB. 5-4-2010, FILED 6-15-2009.



NO CLAIM IS MADE TO THE EXCLUSIVE RIGHT TO USE "VIDEO" AND "PROFESSIONAL VIDEOS FOR PROFESSIONALS", APART FROM THE MARK AS SHOWN.

THE MARK CONSISTS OF THE DESIGN OF A BRAIN FEATURING A CIRCULAR AND TRIANGULAR DESIGN IN THE CENTER OF THE DESIGN AND THE WORDS "INTELLIGENT VIDEO SOLUTIONS" WITH "2" TRIANGULAR ARROW SYMBOLS ON EACH SIDE OF THE WORD "SOLUTIONS" AND THE WORDS "PROFESSIONAL VIDEOS FOR PROFESSIONALS".

FOR VIDEO AND FILM PRODUCTION AND VIDEO AND FILM PRODUCTION CONSULTING SERVICES FOR VIDEO AND FILM USED IN ADVERTISING AND MARKETING IN THE PROFESSIONAL SERVICE INDUSTRIES NAMELY, ACCOUNTING, FINANCE, LEGAL, MANAGEMENT CONSULTING AND NON PROFIT (U.S. CLS. 100, 101 AND 107).

FIRST USE 3-23-2009; IN COMMERCE 10-12-2009.

OWNER OF U.S. REG. NOS. 558,879, 1,166,461, AND 2,363,333.

NO CLAIM IS MADE TO THE EXCLUSIVE RIGHT TO USE "PREFERRED ASSOCIATE", APART FROM THE MARK AS SHOWN.

THE MARK CONSISTS OF "EPA" IN WHITE STYLIZED LETTERS WITHIN A BLACK SQUARE SHAPE WITH THE WORDS "ETS PREFERRED ASSOCIATE" TO THE RIGHT OF THE SHAPE IN STYLIZED LETTERS.

FOR TEST ADMINISTRATION SERVICES, NAMELY, ADMINISTRATION OF A STANDARDIZED EDUCATIONAL TEST; TEST SCORING SERVICES AND TEST SCORE REPORTING SERVICES (U.S. CLS. 100, 101 AND 107).

FIRST USE 10-9-2009; IN COMMERCE 10-9-2009.

CLASS 41—(Continued).

4,016,367. ESSDRAS M SUAREZ, DBA VISYOGA, WATER-TOWN, MA. SN 77-774,161. PUB. 11-24-2009, FILED 7-3-2009.



THE STIPPLING IS FOR SHADING PURPOSES ONLY.
THE MARK CONSISTS OF A CAPITAL LETTER "Y" WITH A SMALL COUNTER-CLOCKWISE SWIRL NESTLED IN THE CROOK OF THE LETTER "Y".
FOR YOGA INSTRUCTION (U.S. CLS. 100, 101 AND 107).
FIRST USE 6-24-2008; IN COMMERCE 12-2-2010.

4,016,387. LIFEFORCE, LLC, BURR RIDGE, IL. SN 77-807,098. PUB. 11-16-2010, FILED 8-18-2009.

JAZZ THAT ROCKS

THE MARK CONSISTS OF STANDARD CHARACTERS WITHOUT CLAIM TO ANY PARTICULAR FONT, STYLE, SIZE, OR COLOR.
NO CLAIM IS MADE TO THE EXCLUSIVE RIGHT TO USE "JAZZ", APART FROM THE MARK AS SHOWN.
FOR ENTERTAINMENT SERVICES IN THE NATURE OF LIVE MUSICAL PERFORMANCES (U.S. CLS. 100, 101 AND 107).
FIRST USE 4-30-2008; IN COMMERCE 4-30-2008.

CLASS 41—(Continued).

4,016,393. BARRETT, JOHN BENJAMIN, LOS ANGELES, CA. SN 77-817,925. PUB. 1-26-2010, FILED 9-1-2009.

Caveman Bodies In A Corporate Jungle

THE MARK CONSISTS OF STANDARD CHARACTERS WITHOUT CLAIM TO ANY PARTICULAR FONT, STYLE, SIZE, OR COLOR.

FOR ENTERTAINMENT AND EDUCATIONAL SERVICES, NAMELY, THE PRESENTATION OF SEMINARS, LECTURES, WORKSHOPS AND PANEL DISCUSSIONS, AND ONGOING TELEVISION AND RADIO TALK SHOWS ALL IN THE FIELD OF PUBLIC INTEREST CONCERNING MAINTAINING HEALTH WHILE EXCELLING IN A CORPORATE ENVIRONMENT (U.S. CLS. 100, 101 AND 107).
FIRST USE 5-15-2010; IN COMMERCE 5-15-2010.

4,016,404. OPEN MEDIA FOUNDATION DBA DEPRODUCTION, DENVER, CO. SN 77-834,035. PUB. 12-21-2010, FILED 9-24-2009.

Open Media Foundation

THE MARK CONSISTS OF STANDARD CHARACTERS WITHOUT CLAIM TO ANY PARTICULAR FONT, STYLE, SIZE, OR COLOR.
NO CLAIM IS MADE TO THE EXCLUSIVE RIGHT TO USE "MEDIA FOUNDATION", APART FROM THE MARK AS SHOWN.
FOR FILM AND VIDEO PRODUCTION (U.S. CLS. 100, 101 AND 107).
FIRST USE 11-19-2009; IN COMMERCE 11-19-2009.

CLASS 41—(Continued).

4,016,438. CHANGYOU.COM (US), INC, WILMINGTON, DE. SN 77-871,355. PUB. 4-13-2010, FILED 11-12-2009.

Blade Wars

THE MARK CONSISTS OF STANDARD CHARACTERS WITHOUT CLAIM TO ANY PARTICULAR FONT, STYLE, SIZE, OR COLOR.

FOR ENTERTAINMENT SERVICES, NAMELY, PROVIDING ON-LINE COMPUTER GAMES; PHOTOGRAPHY; VIDEOTAPE PRODUCTION; MUSIC PRODUCTION SERVICES; PRODUCTION OF RADIO AND TELEVISION PROGRAMS; PROVIDING ON-LINE NON-DOWNLOADABLE ELECTRONIC DICTIONARIES; DUBBING SERVICES; TEACHING AND TRAINING IN BUSINESS, INDUSTRY AND INFORMATION TECHNOLOGY; VOCATIONAL GUIDANCE; EDUCATION INFORMATION; ANIMAL TRAINING (U.S. CLS. 100, 101 AND 107).

FIRST USE 3-16-2010; IN COMMERCE 3-16-2010.

4,016,442. KAUFMAN, JAMES J., DBA DOWNSTREAM PUBLISHING, WILMINGTON, NC. SN 77-874,176. PUB. 4-27-2010, FILED 11-17-2009.

DOWNSTREAM PUBLISHING

THE MARK CONSISTS OF STANDARD CHARACTERS WITHOUT CLAIM TO ANY PARTICULAR FONT, STYLE, SIZE, OR COLOR.

NO CLAIM IS MADE TO THE EXCLUSIVE RIGHT TO USE "PUBLISHING", APART FROM THE MARK AS SHOWN.

FOR BOOK PUBLISHING; ONLINE ELECTRONIC PUBLISHING OF BOOKS (U.S. CLS. 100, 101 AND 107).

FIRST USE 1-30-2011; IN COMMERCE 1-30-2011.

CLASS 41—(Continued).

4,016,474. PROJECT S.L.I.D.E. (SAVING LIVES IN DANCE EDUCATION), ATLANTA, GA. SN 77-888,164. PUB. 11-16-2010, FILED 12-7-2009.



NO CLAIM IS MADE TO THE EXCLUSIVE RIGHT TO USE "PROJECT", APART FROM THE MARK AS SHOWN.

THE COLOR(S) RED, BLACK, AND WHITE IS/ARE CLAIMED AS A FEATURE OF THE MARK.

THE MARK CONSISTS OF THE WORDING "PROJECT S.L.I.D.E. SAVING LIVES IN DANCE EDUCATION". THE WORD "S.L.I.D.E." IS IN THE COLOR BLACK AND IS IN A BOLD FONT ALL CAPS. THE PHRASE "SAVING LIVES IN DANCE EDUCATION" IS DIRECTLY UNDER THE WORD "S.L.I.D.E." INSIDE A SOLID BLACK RECTANGLE IN A RED NARROW FONT ALL CAPS. THE WORD "PROJECT" IS IN A RED NARROW FONT LOCATED DIRECTLY ABOVE THE LETTERS "D" AND "E" IN THE WORD "S.L.I.D.E." A SILHOUETTE OF A MAN IN A DANCER POSE WITH ONE ARM STRETCHED OUT IN FRONT OF HIM AND ONE ARM STRETCHED OUT BEHIND HIM. BOTH KNEES ARE BENT ONE TOE IS SLIGHTLY ABOVE THE LETTER "R" IN THE WORD "PROJECT" AND ONE TOE IS TOUCHING THE LETTER "I" IN "S.L.I.D.E."

FOR DANCE INSTRUCTION FOR CHILDREN, DANCE INSTRUCTION, DANCE SCHOOLS, DANCE STUDIOS; EDUCATION SERVICES, NAMELY, PROVIDING DANCE CLASS AND INSTRUCTION IN THE FIELD OF DANCE (U.S. CLS. 100, 101 AND 107).

FIRST USE 7-15-2010; IN COMMERCE 8-10-2010.

4,016,557. WARNER/CHAPPELL PRODUCTION MUSIC, INC., LOS ANGELES, CA. SN 77-920,179. PUB. 11-2-2010, FILED 1-26-2010.

SONG STREET RECORDS

THE MARK CONSISTS OF STANDARD CHARACTERS WITHOUT CLAIM TO ANY PARTICULAR FONT, STYLE, SIZE, OR COLOR.

NO CLAIM IS MADE TO THE EXCLUSIVE RIGHT TO USE "SONG" OR "RECORDS", APART FROM THE MARK AS SHOWN.

FOR MUSIC LIBRARY SERVICES; PRODUCTION MUSIC LIBRARY SERVICES; MUSIC PRODUCTION SERVICES; COMPOSITION OF MUSIC FOR OTHERS; DEVELOPMENT, CREATION, PRODUCTION AND RECORDING OF NEW MUSIC PACKAGES, NAMELY, SOUND RECORDINGS FOR USE OR EXPLOITATION IN FILM, TELEVISION, OR OTHER MEDIA OUTLETS OR ELECTRONIC COMMUNICATION NETWORKS; DEVELOPMENT, CREATION AND PRODUCTION OF SOUND RECORDINGS (U.S. CLS. 100, 101 AND 107).

FIRST USE 3-28-2010; IN COMMERCE 3-28-2010.

CLASS 41—(Continued).

4,016,574. WARNER/CHAPPELL PRODUCTION MUSIC, INC., LOS ANGELES, CA. SN 77-931,044. PUB. 11-2-2010, FILED 2-8-2010.



NO CLAIM IS MADE TO THE EXCLUSIVE RIGHT TO USE "SONG" OR "RECORDS", APART FROM THE MARK AS SHOWN.

THE MARK CONSISTS OF TWO CONCENTRIC CIRCLES, AND TWO VERTICAL LINES, APPEARING NEAR THE LITERAL ELEMENT, "SONG STREET RECORDS", AND WITHIN THE INNER, PARTIALLY SHADED CIRCLE.

FOR MUSIC LIBRARY SERVICES; PRODUCTION MUSIC LIBRARY SERVICES; MUSIC PRODUCTION SERVICES; COMPOSITION OF MUSIC FOR OTHERS; DEVELOPMENT, CREATION, PRODUCTION AND RECORDING OF NEW MUSIC PACKAGES, NAMELY, SOUND RECORDINGS FOR USE OR EXPLOITATION IN FILM, TELEVISION, OR OTHER MEDIA OUTLETS OR ELECTRONIC COMMUNICATION NETWORKS; DEVELOPMENT, CREATION AND PRODUCTION OF SOUND RECORDINGS (U.S. CLS. 100, 101 AND 107).
FIRST USE 3-28-2010; IN COMMERCE 3-28-2010.

4,016,581. UHY ADVISORS, INC., CHICAGO, IL. SN 77-934,329. PUB. 11-23-2010, FILED 2-12-2010.



NO CLAIM IS MADE TO THE EXCLUSIVE RIGHT TO USE "FINANCIAL LEADERS SEMINAR", APART FROM THE MARK AS SHOWN.

THE MARK CONSISTS OF THE WORDS "FINANCIAL LEADERS SEMINAR" BENEATH THE TERM "FLS" IN STYLIZED UPPER CASE LETTERS; FROM THE RIGHT SIDE OF EACH OF THE STYLIZED UPPERCASE LETTERS EXTENDS A CURVED HORIZONTAL LINE; THE LINES CROSS OVER EACH OTHER ON THE RIGHT CENTER OF THE IMAGE AND FAN OUTWARD ON THE RIGHT SIDE OF THE IMAGE.

FOR CONDUCTING WORKSHOPS AND SEMINARS IN THE FIELDS OF CONTINUING BUSINESS EDUCATION, BUSINESS TRAINING, AND STRATEGIC PLANNING RELATED TO BUSINESS, ALL DIRECTED TO PROFESSIONALS (U.S. CLS. 100, 101 AND 107).
FIRST USE 3-12-2010; IN COMMERCE 3-12-2010.

CLASS 41—(Continued).

4,016,616. BREATH OF HOPE FOUNDATION, INC., HOUSTON, TN. SN 77-946,632. PUB. 2-1-2011, FILED 2-27-2010.



THE COLOR(S) BLUE, BLACK, WHITE AND GRAY IS/ARE CLAIMED AS A FEATURE OF THE MARK.

THE MARK CONSISTS OF A RECTANGULAR TUBE SHAPED FIGURE WITH HUMAN ATTRIBUTES. THE TUBE IS IN BLUE, WITH BLACK OUTLINING AND HIGHLIGHTS, AND A WHITE CIRCULAR TOP OUTLINED IN BLACK, WITH BLUE HIGHLIGHTS. THE ARMS, LEGS AND EYEBROWS, ARE BLACK WITH GRAY HIGHLIGHTS. THE MOUTH AND EYES ARE BLACK AND WHITE.

FOR EDUCATIONAL SERVICES, NAMELY, PROVIDING DISPLAYS AND EXHIBITS IN THE FIELD OF ASTHMA AWARENESS AND PREVENTION; EDUCATIONAL SERVICES, NAMELY, PROVIDING ON-LINE COURSES, CLASSES, SEMINARS, AND WORKSHOPS IN THE FIELD OF ASTHMA AWARENESS AND PREVENTION; EDUCATIONAL SERVICES, NAMELY, PROVIDING COURSES, CLASSES, SEMINARS AND WORKSHOPS IN THE FIELDS OF ASTHMA AWARENESS AND PREVENTION; ENTERTAINMENT AND EDUCATIONAL SERVICES, NAMELY, THE PRESENTATION OF SEMINARS, LECTURES, WORKSHOPS AND PANEL DISCUSSIONS, AND ONGOING TELEVISION AND RADIO TALK SHOWS ALL IN THE FIELD OF PUBLIC INTEREST CONCERNING ASTHMA AWARENESS AND PREVENTION (U.S. CLS. 100, 101 AND 107).
FIRST USE 12-0-2010; IN COMMERCE 12-0-2010.

4,016,618. GFY ENTERTAINMENT, INC., DBA GFY POKER NIGHTS, RALEIGH, NC. SN 77-946,954. PUB. 11-2-2010, FILED 3-1-2010.



NO CLAIM IS MADE TO THE EXCLUSIVE RIGHT TO USE "POKER", APART FROM THE MARK AS SHOWN.

THE COLOR(S) RED, WHITE, BLACK, AND GREY IS/ARE CLAIMED AS A FEATURE OF THE MARK.

THE MARK CONSISTS OF FIVE PLAYING CARDS ARRANGED IN THE SHAPE OF A HAND-HELD FAN SO THAT ONLY THE TOP LEFT CORNER OF EACH CARD AND ITS RESPECTIVE DENOMINATION IS SHOWING. IN THE WAY THAT CARD PLAYERS TYPICALLY HOLD A HAND OF CARDS, AND WITH THE FIRST CARD SHOWING A SILHOUETTE OF A FEMALE FIGURE ABOVE A

CLASS 41—(Continued).

GAME PIECE, AND WITH THE SECOND CARD SHOWING THE LETTER "G" OVER A HEART, AND WITH THE THIRD CARD SHOWING A LETTER "F" ABOVE A HEART, AND WITH THE FOURTH CARD SHOWING THE LETTER "Y" ABOVE A HEART, AND WITH THE FIFTH CARD SHOWING THE SILHOUETTE OF A WOMAN ABOVE A GAME PIECE, AND WITH THE HAND OF CARDS BEING BORDERED ABOVE AND ON EACH SIDE BY A SEMICIRCULAR BACKGROUND, AND WITH THE HAND OF CARDS AND THEIR BACKGROUND BEING ALL SITUATED ABOVE A RECTANGLE WITH ROUNDED CORNERS THAT CONTAINS THE WORDS "POKER NIGHTS" IN ALL CAPITAL LETTERS, AND WITH A BORDER SURROUNDING THE RECTANGLE, WITH THE EXCEPTION OF THE TOP PORTION OF THE RECTANGLE. THE COLORS RED, WHITE AND BLACK APPEAR IN THE WORDS "POKER NIGHTS". THE COLORS RED, GREY AND BLACK APPEAR IN THE RECTANGLE ENCLOSING THE WORDS "POKER NIGHTS". THE COLOR BLACK APPEARS IN THE SEMI-CIRCLE AND SILHOUETTES. THE COLORS RED AND WHITE APPEAR IN THE GAME PIECES. THE COLORS GREY, RED, BLACK AND WHITE APPEAR IN THE CARDS.

FOR ENTERTAINMENT SERVICES, NAMELY, SPECIAL EVENT PLANNING FOR SOCIAL ENTERTAINMENT PURPOSES ONLY AND PARTY PLANNING FEATURING CASINO THEMED GAMES, NOT INCLUDING GAMBLING (U.S. CLS. 100, 101 AND 107).

FIRST USE 12-8-2009; IN COMMERCE 5-5-2011.

4,016,633. FOARD, NEAL, WAYNE, NJ. SN 77-953,546. PUB. 7-27-2010, FILED 3-8-2010.

MORPHEONICS

THE MARK CONSISTS OF STANDARD CHARACTERS WITHOUT CLAIM TO ANY PARTICULAR FONT, STYLE, SIZE, OR COLOR.

FOR EDUCATION SERVICES, NAMELY, PROVIDING CLASSES, SEMINARS, WORKSHOPS IN THE FIELD OF HYPNOTHERAPY (U.S. CLS. 100, 101 AND 107).

FIRST USE 2-24-2011; IN COMMERCE 2-24-2011.

4,016,655. DONELY, JADANA, DBA RED CARPET EVENT PLANNING, OCEANSIDE, CA. SN 77-964,658. PUB. 10-5-2010, FILED 3-22-2010.



NO CLAIM IS MADE TO THE EXCLUSIVE RIGHT TO USE "EVENT PLANNING", APART FROM THE MARK AS SHOWN.

THE COLOR(S) RED, BLACK AND WHITE IS/ARE CLAIMED AS A FEATURE OF THE MARK.

THE MARK CONSISTS OF THE STYLIZED WORDING "RED CARPET EVENT PLANNING WHERE YOU ARE THE STAR!" AND A DESIGN ELEMENT CONSISTING OF A FEMALE SILHOUETTE STANDING AT THE TOP OF RED

CLASS 41—(Continued).

CARPET WITH SIX MALE PHOTOGRAPHERS SILHOUETTES ON EITHER SIDE OF THE CARPET. THE SILHOUETTES APPEAR IN THE COLOR BLACK. THE WORDING "WHERE YOU ARE THE STAR!" APPEARS IN WHITE ON THE CARPET, AND THE WORDING "RED CARPET EVENT PLANNING" APPEARS TO THE LEFT OF THE FEMALE FIGURE. THE WORD "RED" APPEARS IN THE COLOR RED. THE WORDING "CARPET" AND "EVENT PLANNING" APPEARS IN THE COLOR BLACK. THE WORDS "CARPET" AND "PLANNING" SHARE THE LETTER "P".

FOR SPECIAL EVENT PLANNING FOR SOCIAL ENTERTAINMENT PURPOSES; PARTY AND WEDDING PLANNING, COORDINATION AND CONSULTATION SERVICES (U.S. CLS. 100, 101 AND 107).

FIRST USE 2-1-2011; IN COMMERCE 2-8-2011.

4,016,656. ASTOR HOME LTD., EAST RUTHERFORD, NJ. SN 77-964,951. PUB. 10-5-2010, FILED 3-22-2010.

SLOWER EAST SIDE

THE MARK CONSISTS OF STANDARD CHARACTERS WITHOUT CLAIM TO ANY PARTICULAR FONT, STYLE, SIZE, OR COLOR.

NO CLAIM IS MADE TO THE EXCLUSIVE RIGHT TO USE "EAST SIDE", APART FROM THE MARK AS SHOWN.

FOR EDUCATIONAL SERVICES, NAMELY, CONDUCTING PROGRAMS IN THE FIELD OF FOOD, BEVERAGES, FOOD AND BEVERAGE PAIRINGS; WINE, SPIRITS AND BEERS; MIXED DRINKS, HISTORY, CURRENT AFFAIRS, LOCAL INTERESTS, CULTURAL AFFAIRS AND REDUCING ONES CARBON FOOTPRINT; EDUCATIONAL SERVICES, NAMELY, CONDUCTING CLASSES, SEMINARS, WORKSHOPS, TASTINGS, WALKING TOURS AND EDUCATIONAL DEMONSTRATIONS IN THE FIELD OF FOOD, BEVERAGES, FOOD AND BEVERAGE PAIRINGS; WINE, SPIRITS AND BEERS; MIXED DRINKS, HISTORY, CURRENT AFFAIRS, LOCAL INTERESTS, CULTURAL AFFAIRS AND REDUCING ONES CARBON FOOTPRINT AND DISTRIBUTING EDUCATIONAL MATERIALS IN CONNECTION THEREWITH; EDUCATIONAL SERVICES, NAMELY, CONDUCTING CLASSES, SEMINARS, WORKSHOPS, TASTINGS, WALKING TOURS AND EDUCATIONAL DEMONSTRATIONS IN THE FIELD OF FOOD, BEVERAGES, FOOD AND BEVERAGE PAIRINGS; WINE, SPIRITS AND BEERS; MIXED DRINKS, HISTORY, CURRENT AFFAIRS, LOCAL INTERESTS, CULTURAL AFFAIRS AND REDUCING ONES CARBON FOOTPRINT; EDUCATIONAL SERVICES, NAMELY, PROVIDING EDUCATIONAL DISPLAYS AND EXHIBITS IN THE FIELD OF FOOD, BEVERAGES, FOOD AND BEVERAGE PAIRINGS; WINE, SPIRITS AND BEERS; MIXED DRINKS, HISTORY, CURRENT AFFAIRS, LOCAL INTERESTS, CULTURAL AFFAIRS AND REDUCING ONES CARBON FOOTPRINT; EDUCATIONAL SERVICES, NAMELY, PROVIDING CLASSES, SEMINARS, WORKSHOPS, TASTINGS, WALKING TOURS AND EDUCATIONAL DEMONSTRATIONS IN THE FIELDS OF FOOD, BEVERAGES, FOOD AND BEVERAGE PAIRINGS; WINE, SPIRITS AND BEERS; MIXED DRINKS, HISTORY, CURRENT AFFAIRS, LOCAL INTERESTS, CULTURAL AFFAIRS AND REDUCING ONES CARBON FOOTPRINT; ENTERTAINMENT SERVICES, NAMELY, PERSONAL APPEARANCES BY CHEFS, BARTENDERS, CELEBRITIES, LOCAL BUSINESS OWNERS AND RETAILERS, EDUCATORS, ENTERTAINERS AND ENGINEERS; ENTERTAINMENT SERVICES, NAMELY, PROVIDING PODCASTS IN THE FIELD OF FOOD, BEVERAGES, FOOD AND BEVERAGE PAIRINGS; WINE, SPIRITS

CLASS 41—(Continued).

AND BEERS; MIXED DRINKS, HISTORY, CURRENT AFFAIRS, LOCAL INTERESTS, CULTURAL AFFAIRS, REDUCING ONES CARBON FOOTPRINT AND SELF-GUIDED TOURS; ENTERTAINMENT SERVICES, NAMELY, PROVIDING WEBCASTS IN THE FIELD OF FOOD, BEVERAGES, FOOD AND BEVERAGE PAIRINGS; WINE, SPIRITS AND BEERS; MIXED DRINKS, HISTORY, CURRENT AFFAIRS, LOCAL INTERESTS, CULTURAL AFFAIRS, REDUCING ONES CARBON FOOTPRINT AND GUIDED TOURS; ENTERTAINMENT SERVICES, NAMELY, THE PROVISION OF CONTINUING CLASSES, SEMINARS, WORKSHOPS, TASTINGS, WALKING TOURS AND EDUCATIONAL DEMONSTRATIONS FEATURING FOOD, BEVERAGES, FOOD AND BEVERAGE PAIRINGS; WINE, SPIRITS AND BEERS; MIXED DRINKS, HISTORY, CURRENT AFFAIRS, LOCAL INTERESTS, CULTURAL AFFAIRS AND REDUCING ONES CARBON FOOTPRINT DELIVERED BY CHEFS, BARTENDERS, CELEBRITIES, LOCAL BUSINESS OWNERS AND RETAILERS, EDUCATORS, ENTERTAINERS, TOUR GUIDES AND ENGINEERS; ENTERTAINMENT SERVICES, NAMELY, WINE AND FOOD TASTINGS (U.S. CLS. 100, 101 AND 107).
FIRST USE 6-3-2011; IN COMMERCE 6-3-2011.

4,016,671. WORTSMAN, MICHAEL D., PALOS VERDES ESTATES, CA. SN 77-981,929. PUB. 5-27-2008, FILED 11-21-2007.

REINA POR UN DIA

THE MARK CONSISTS OF STANDARD CHARACTERS WITHOUT CLAIM TO ANY PARTICULAR FONT, STYLE, SIZE, OR COLOR.

OWNER OF U.S. REG. NO. 1,163,128.

THE ENGLISH TRANSLATION OF "REINA POR UN DIA" IS "QUEEN FOR ONE DAY".

FOR ENTERTAINMENT SERVICES IN THE NATURE OF AN ON-GOING SPANISH LANGUAGE REALITY BASED TELEVISION PROGRAM (U.S. CLS. 100, 101 AND 107).

FIRST USE 3-23-2011; IN COMMERCE 3-23-2011.

4,016,680. WILCOXEN, TRACY HEATHER, LOS ANGELES, CA. AND RUSSO, MIRANDA KATE, LOS ANGELES, CA. SN 77-982,109. PUB. 9-23-2008, FILED 11-7-2007.

WING GIRLS

THE MARK CONSISTS OF STANDARD CHARACTERS WITHOUT CLAIM TO ANY PARTICULAR FONT, STYLE, SIZE, OR COLOR.

FOR ON-LINE JOURNALS, NAMELY, BLOGS FEATURING ADVICE IN THE CATEGORIES OF DATING, IMAGE, FASHION AND RELATIONSHIPS (U.S. CLS. 100, 101 AND 107).

FIRST USE 4-30-2006; IN COMMERCE 4-30-2006.

CLASS 41—(Continued).

4,016,684. LINKEDIN CORPORATION, MOUNTAIN VIEW, CA. SN 77-982,134. PUB. 5-18-2010, FILED 7-16-2009.



OWNER OF U.S. REG. NOS. 3,074,241, 3,074,242, AND 3,303,349.

THE MARK CONSISTS OF THE WORD "IN" SHOWN INSIDE A SQUARE WITH A SHADED BACKGROUND.

FOR ENTERTAINMENT AND EDUCATIONAL SERVICES, NAMELY, CONDUCTING SEMINARS, WORKSHOPS, CONFERENCES AND EXHIBITIONS FEATURING INSTRUCTIONAL PRESENTATIONS IN THE FIELDS OF PERSONAL DEVELOPMENT, CAREER DEVELOPMENT, RELATIONSHIP BUILDING AND SOCIAL NETWORKING; ENTERTAINMENT AND EDUCATIONAL SERVICES, NAMELY, CONDUCTING DISCUSSION GROUPS IN THE FIELDS OF PERSONAL DEVELOPMENT, CAREER DEVELOPMENT, RELATIONSHIP BUILDING AND SOCIAL NETWORKING; ON-LINE JOURNALS, NAMELY, BLOGS FEATURING INFORMATION ABOUT PERSONAL DEVELOPMENT AND CAREER DEVELOPMENT; ONLINE ELECTRONIC PUBLISHING SERVICES, NAMELY, PUBLICATION OF TEXT AND GRAPHIC WORKS OF OTHERS FEATURING INFORMATION REGARDING TOPICS OF PROFESSIONAL INTEREST (U.S. CLS. 100, 101 AND 107).

FIRST USE 9-0-2007; IN COMMERCE 9-0-2007.

4,016,685. LINKEDIN CORPORATION, MOUNTAIN VIEW, CA. SN 77-982,140. PUB. 5-18-2010, FILED 7-16-2009.

LINKEDIN

THE MARK CONSISTS OF STANDARD CHARACTERS WITHOUT CLAIM TO ANY PARTICULAR FONT, STYLE, SIZE, OR COLOR.

CLASS 41—(Continued).

OWNER OF U.S. REG. NOS. 3,074,241, 3,074,242, AND 3,303,349.

FOR ENTERTAINMENT AND EDUCATIONAL SERVICES, NAMELY, CONDUCTING SEMINARS, WORKSHOPS, CONFERENCES AND EXHIBITIONS FEATURING INSTRUCTIONAL PRESENTATIONS IN THE FIELDS OF PERSONAL DEVELOPMENT, CAREER DEVELOPMENT, RELATIONSHIP BUILDING AND SOCIAL NETWORKING; ENTERTAINMENT AND EDUCATIONAL SERVICES, NAMELY, CONDUCTING DISCUSSION GROUPS IN THE FIELDS OF PERSONAL DEVELOPMENT, CAREER DEVELOPMENT, RELATIONSHIP BUILDING AND SOCIAL NETWORKING; ON-LINE JOURNALS, NAMELY, BLOGS FEATURING INFORMATION ABOUT PERSONAL DEVELOPMENT AND CAREER DEVELOPMENT; ONLINE ELECTRONIC PUBLISHING SERVICES, NAMELY, PUBLICATION OF TEXT AND GRAPHIC WORKS OF OTHERS FEATURING INFORMATION REGARDING TOPICS OF PROFESSIONAL INTEREST (U.S. CLS. 100, 101 AND 107).

FIRST USE 9-0-2007; IN COMMERCE 9-0-2007.

4,016,687. LINKEDIN CORPORATION, MOUNTAIN VIEW, CA. SN 77-982,144. PUB. 5-11-2010, FILED 7-16-2009.



OWNER OF U.S. REG. NOS. 3,074,241, 3,074,242, AND 3,303,349.

THE COLOR(S) BLUE AND WHITE IS/ARE CLAIMED AS A FEATURE OF THE MARK.

THE MARK CONSISTS OF THE WORD "IN" SHOWN IN WHITE LETTERS INSIDE A BLUE SQUARE.

FOR ENTERTAINMENT AND EDUCATIONAL SERVICES, NAMELY, CONDUCTING SEMINARS, WORKSHOPS, CONFERENCES AND EXHIBITIONS FEATURING INSTRUCTIONAL PRESENTATIONS IN THE FIELDS OF PERSONAL DEVELOPMENT, CAREER DEVELOPMENT, RELATIONSHIP BUILDING AND SOCIAL NETWORKING; ENTERTAINMENT AND EDUCATIONAL SERVICES, NAMELY, CONDUCTING DISCUSSION GROUPS IN THE FIELDS OF PERSONAL DEVELOPMENT, CAREER DEVELOPMENT, RELATIONSHIP BUILDING AND SOCIAL NETWORKING; ON-LINE JOURNALS, NAMELY, BLOGS FEATURING INFORMATION ABOUT PERSONAL DEVELOPMENT AND CAREER DEVELOPMENT; ONLINE ELECTRONIC PUBLISHING SERVICES, NAMELY, PUBLICATION OF TEXT AND GRAPHIC WORKS OF OTHERS FEATURING INFORMATION REGARDING TOPICS OF PROFESSIONAL INTEREST (U.S. CLS. 100, 101 AND 107).

FIRST USE 9-0-2007; IN COMMERCE 9-0-2007.

CLASS 41—(Continued).

4,016,708. TENCENT HOLDINGS LIMITED, GEORGE TOWN, GC, CAYMAN ISLANDS. SN 77-982,297. PUB. 5-11-2010, FILED 1-11-2010.



THE MARK CONSISTS OF THE STYLIZED WORDS "RANCH LIFE" BELOW FOUR ANIMALS, NAMELY A DUCK STANDING IN FRONT OF FLOWERS, NEXT TO A COW STANDING WITH A FLOWER BEHIND ITS EAR, NEXT TO A SHEEP STANDING BESIDE GRASS AND ROCKS, AND ON TOP OF THE COW, A SQUIRREL SITTING WITH A FLOWER BEHIND ITS EAR AND HOLDING AN ACORN.

FOR ENTERTAINMENT AND EDUCATION SERVICES, NAMELY, PROVIDING ONLINE GAMES IN THE NATURE OF COMPUTER CONTESTS; PROVIDING ONLINE COMPUTER GAMES (U.S. CLS. 100, 101 AND 107).

FIRST USE 2-0-2010; IN COMMERCE 2-0-2010.

4,016,774. ARIZONA LIVING LIGHT LLC, SCOTTSDALE, AZ. SN 85-024,721. PUB. 9-28-2010, FILED 4-27-2010.

MODERN MASTERY

THE MARK CONSISTS OF STANDARD CHARACTERS WITHOUT CLAIM TO ANY PARTICULAR FONT, STYLE, SIZE, OR COLOR.

FOR EDUCATION AND TRAINING SERVICES, NAMELY, PROVIDING MENTORING, CLASSES, WORKSHOPS AND RETREATS IN THE FIELD OF PERSONAL SPIRITUAL GROWTH AND DEVELOPMENT AND INSTRUCTION ON THE INTEGRATION OF MIND, BODY, HEART AND SPIRIT (U.S. CLS. 100, 101 AND 107).

FIRST USE 1-2-2010; IN COMMERCE 3-1-2011.

CLASS 41—(Continued).

4,016,800. TURNER NETWORK TELEVISION, INC., ATLANTA, GA. SN 85-035,605. PUB. 3-29-2011, FILED 5-11-2010.

FALLING SKIES

THE MARK CONSISTS OF STANDARD CHARACTERS WITHOUT CLAIM TO ANY PARTICULAR FONT, STYLE, SIZE, OR COLOR.

FOR ENTERTAINMENT SERVICES, NAMELY, A MULTIMEDIA PROGRAM SERIES FEATURING SCIENCE FICTION AND DRAMA DISTRIBUTED VIA VARIOUS PLATFORMS ACROSS MULTIPLE FORMS OF TRANSMISSION MEDIA (U.S. CLS. 100, 101 AND 107).
FIRST USE 6-19-2011; IN COMMERCE 6-19-2011.

CLASS 41—(Continued).

4,016,819. MINUS ZERO, DBA 360 INFLUENCE LLC, IRVINE, CA. SN 85-041,875. PUB. 10-19-2010, FILED 5-18-2010.



THE MARK CONSISTS OF FIVE SYMBOLS WHERE IN SYMBOL ONE CONTAINS A RECTANGLE WITHIN A CIRCLE, SYMBOL TWO CONTAINS A RECTANGLE AND NEW MOON WITHIN A CIRCLE, SYMBOL THREE CONTAINS A RECTANGLE AND HALF-MOON WITHIN A CIRCLE, SYMBOL FOUR CONTAINS A RECTANGLE AND THREE-QUARTER MOON, AND SYMBOL FIVE CONTAINS A RECTANGLE AND FULL MOON.

FOR BUSINESS EDUCATION AND TRAINING SERVICES, NAMELY, DEVELOPING, AND FACILITATING CUSTOMIZED IN-COMPANY LEADERSHIP AND EXECUTIVE DEVELOPMENT PROGRAMS, PROVIDING EXECUTIVE COACHING SERVICES, AND PROVIDING PUBLIC AND IN-COMPANY KEYNOTE PRESENTATIONS TO BUSINESS LEADERS (U.S. CLS. 100, 101 AND 107).
FIRST USE 7-17-2010; IN COMMERCE 7-17-2010.

4,016,822. CHAMBERS-BELIDA, CANDACE, CORONA, CA. SN 85-042,749. PUB. 10-19-2010, FILED 5-19-2010.

Love-a-licious!

THE MARK CONSISTS OF STANDARD CHARACTERS WITHOUT CLAIM TO ANY PARTICULAR FONT, STYLE, SIZE, OR COLOR.

FOR ENTERTAINMENT IN THE NATURE OF A TELEVISION TALK SHOW SERIES (U.S. CLS. 100, 101 AND 107).
FIRST USE 10-1-2010; IN COMMERCE 4-12-2011.

BLINK

4,016,826. AMERICAN UNIVERSITY, WASHINGTON, DC. SN 85-043,796. PUB. 10-26-2010, FILED 5-20-2010.

Arts Wonk

THE MARK CONSISTS OF STANDARD CHARACTERS WITHOUT CLAIM TO ANY PARTICULAR FONT, STYLE, SIZE, OR COLOR.

FOR EDUCATIONAL SERVICES, NAMELY, CONDUCTING COURSES IN THE FIELD OF HEALTH AND WELLNESS; HEALTH CLUB SERVICES, NAMELY, PROVIDING INSTRUCTION AND EQUIPMENT IN THE FIELD OF PHYSICAL EXERCISE; PHYSICAL FITNESS TRAINING SERVICES; PROVIDING FITNESS AND EXERCISE FACILITIES (U.S. CLS. 100, 101 AND 107).
FIRST USE 1-7-2011; IN COMMERCE 1-7-2011.

THE MARK CONSISTS OF STANDARD CHARACTERS WITHOUT CLAIM TO ANY PARTICULAR FONT, STYLE, SIZE, OR COLOR.

CLASS 41—(Continued).

NO CLAIM IS MADE TO THE EXCLUSIVE RIGHT TO USE "ARTS", APART FROM THE MARK AS SHOWN.

FOR EDUCATIONAL SERVICES, NAMELY, PROVIDING EDUCATIONAL PROGRAMS, COURSES OF INSTRUCTION AT THE COLLEGE AND GRADUATE LEVEL, SEMINARS, LECTURES, AND WORKSHOPS IN THE FIELD OF ARTS (U.S. CLS. 100, 101 AND 107).
FIRST USE 6-17-2011; IN COMMERCE 6-17-2011.

CLASS 41—(Continued).

4,016,828. UTOPIC, LLC, CHICAGO, IL. SN 85-044,009. PUB. 10-26-2010, FILED 5-20-2010.



4,016,827. AMERICAN UNIVERSITY, WASHINGTON, DC. SN 85-043,922. PUB. 10-26-2010, FILED 5-20-2010.

Communications Wonk

THE MARK CONSISTS OF STANDARD CHARACTERS WITHOUT CLAIM TO ANY PARTICULAR FONT, STYLE, SIZE, OR COLOR.

NO CLAIM IS MADE TO THE EXCLUSIVE RIGHT TO USE "COMMUNICATIONS", APART FROM THE MARK AS SHOWN.

FOR EDUCATIONAL SERVICES, NAMELY, PROVIDING EDUCATIONAL PROGRAMS, COURSES OF INSTRUCTION AT THE COLLEGE AND GRADUATE LEVEL, SEMINARS, LECTURES, AND WORKSHOPS IN THE FIELD OF COMMUNICATIONS (U.S. CLS. 100, 101 AND 107).

FIRST USE 6-16-2011; IN COMMERCE 6-16-2011.



THE MARK CONSISTS OF A SHADED SMALLER CIRCLE SURROUNDED BY A RING CIRCLE SURROUNDED BY A THICKER OUTSIDE CIRCULAR SHAPED LINED RING WITH TWO NOTCHES EXTENDING OUT DIRECTLY ACROSS FROM EACH OTHER, AND FEATURING TWO BREAKS IN THE RING THAT ARE LOCATED DIRECTLY OPPOSITE EACH OTHER AT 90 DEGREE ANGLES FROM THE NOTCHES.

FOR ANIMATION PRODUCTION SERVICES; AUDIO AND VIDEO RECORDING SERVICES; AUDIO RECORDING AND PRODUCTION; DIGITAL VIDEO, AUDIO, AND MULTIMEDIA PUBLISHING SERVICES; EDITORIAL CONSULTATION; ENTERTAINMENT SERVICES, NAMELY, MULTIMEDIA PRODUCTION SERVICES; ENTERTAINMENT SERVICES, NAMELY, PRODUCTION OF COMPUTER-GENERATED IMAGERY FOR USE IN MOTION PICTURES; ENTERTAINMENT SERVICES, NAMELY, PRODUCTION OF SPECIAL EFFECTS INCLUDING MODEL-MAKING SERVICES AND RELATED PHYSICAL PRODUCTION ELEMENTS FOR USE IN MOTION PICTURES; FILM AND VIDEO PRODUCTION CONSULTING SERVICES; FILM AND VIDEO TAPE FILM PRODUCTION; FILM DISTRIBUTION; FILM EDITING; FILM MASTERING SERVICES; FILM PRODUCTION; FILM RENTAL; FILM STUDIOS; LAYOUT SERVICES OTHER THAN FOR ADVERTISING PURPOSES; MEDIA PRODUCTION SERVICES, NAMELY, VIDEO AND FILM PRODUCTION; MOTION PICTURE FILM PRODUCTION; MOTION PICTURE SONG PRODUCTION; MULTIMEDIA ENTERTAINMENT SERVICES IN THE NATURE OF RECORDING, PRODUCTION AND POST-PRODUCTION SERVICES IN THE FIELDS OF MUSIC, VIDEO, AND FILMS; MUSIC VIDEO PRODUCTION; PRODUCTION AND DISTRIBUTION OF TELEVISION SHOWS AND MOVIES; PRODUCTION OF CABLE TELEVISION PROGRAMS; PRODUCTION OF FILMS; PRODUCTION OF TELEVISION AND RADIO PROGRAMMES; PRODUCTION OF VIDEO AND COMPUTER GAME SOFTWARE; PRODUCTION OF VIDEO AND CREATION OF VISUAL EFFECTS FOR OTHERS FOR USE IN DVDS, TELEVISION PROGRAMS AND ON WEB SITES; PRODUCTION OF VIDEO DISCS AND TAPES; PROVIDING AUDIO OR VIDEO STUDIOS; RECORD MASTER PRODUCTION; RECORD PRODUCTION; SPECIAL EFFECTS ANIMATION SERVICES FOR FILM AND VIDEO; TELEVISION SHOW PRODUCTION; VIDEO PRODUCTION SERVICES (U.S. CLS. 100, 101 AND 107).

FIRST USE 11-1-2009; IN COMMERCE 11-1-2009.

CLASS 41—(Continued).

4,016,830. AMERICAN UNIVERSITY, WASHINGTON, DC.
SN 85-044,067. PUB. 10-26-2010, FILED 5-20-2010.

Research Wonk

THE MARK CONSISTS OF STANDARD CHARACTERS WITHOUT CLAIM TO ANY PARTICULAR FONT, STYLE, SIZE, OR COLOR.

NO CLAIM IS MADE TO THE EXCLUSIVE RIGHT TO USE "RESEARCH", APART FROM THE MARK AS SHOWN.

FOR EDUCATIONAL SERVICES, NAMELY, PROVIDING COURSES OF INSTRUCTION AT THE COLLEGE AND GRADUATE LEVEL, NAMELY, DISTRIBUTING COURSE MATERIALS, CONDUCTING EDUCATIONAL CONFERENCES AND EDUCATIONAL RESEARCH IN THE FIELDS OF POLITICS, SCIENCE, HISTORY, LANGUAGES, COMPUTER TECHNOLOGY, MATH, ARTS, MUSIC (U.S. CLS. 100, 101 AND 107).
FIRST USE 6-16-2011; IN COMMERCE 6-16-2011.

4,016,831. AMERICAN UNIVERSITY, WASHINGTON, DC.
SN 85-044,079. PUB. 10-26-2010, FILED 5-20-2010.

Global Wonk

THE MARK CONSISTS OF STANDARD CHARACTERS WITHOUT CLAIM TO ANY PARTICULAR FONT, STYLE, SIZE, OR COLOR.

NO CLAIM IS MADE TO THE EXCLUSIVE RIGHT TO USE "GLOBAL", APART FROM THE MARK AS SHOWN.

FOR EDUCATIONAL SERVICES, NAMELY, PROVIDING COURSES OF INSTRUCTION AT THE COLLEGE AND GRADUATE LEVEL, NAMELY, DISTRIBUTING COURSE MATERIALS, CONDUCTING EDUCATIONAL CONFERENCES AND EDUCATIONAL RESEARCH IN THE FIELDS OF POLITICS, SCIENCE, HISTORY, LANGUAGES, COMPUTER TECHNOLOGY, MATH, ARTS, MUSIC (U.S. CLS. 100, 101 AND 107).
FIRST USE 6-16-2011; IN COMMERCE 6-16-2011.

CLASS 41—(Continued).

4,016,852. SILDREY, LLC, DOTHAN, AL. SN 85-050,609. PUB. 10-26-2010, FILED 5-28-2010.

SILDREY

THE MARK CONSISTS OF STANDARD CHARACTERS WITHOUT CLAIM TO ANY PARTICULAR FONT, STYLE, SIZE, OR COLOR.

FOR PERSONAL COACHING SERVICES IN THE FIELD OF DIVORCE; PROVIDING EDUCATIONAL MENTORING SERVICES AND PROGRAMS IN THE FIELD OF DIVORCE (U.S. CLS. 100, 101 AND 107).
FIRST USE 7-31-2010; IN COMMERCE 7-31-2010.

4,016,911. TAM HA PROJECT, LLC, SANTA MONICA, CA.
SN 85-066,303. PUB. 3-29-2011, FILED 6-18-2010.



NO CLAIM IS MADE TO THE EXCLUSIVE RIGHT TO USE "TAM HA PROJECT", APART FROM THE MARK AS SHOWN.

THE MARK CONSISTS OF THE STYLIZED WORDS "TAM HA PROJECT" WITHIN A CIRCULAR SHAPED DESIGN. AN IMAGE OF A TECHNICAL DIVER DESCENDING TO DEPTH, RIDING A DPV (DIVER PROPULSION VEHICLE). HE IS FOLLOWED BY A STYLIZED ARROW POINTING TO DEPTH MADE UP OF BUBBLES. BOTH IMAGES ARE SUPER-IMPOSED OVER AND VERTICALLY DISSECT THE MIDDLE OF TWO DISTRESSED CONCENTRIC CIRCLES BETWEEN WHICH THE WORDS: "TAM HA PROJECT" ARE LOCATED. "TAM HA" IN THE LEFT HALF OF THE CIRCLE, "PROJECT" IN THE RIGHT HALF.

THE ENGLISH TRANSLATION OF THE MAYAN WORDS "TAM HA" IN THE MARK IS "DEEP WATER".

FOR PROVIDING EDUCATIONAL SERVICES IN THE FIELD OF UNDERWATER RESEARCH, NAMELY, TRAINING DIVERS TO FIND AND DOCUMENT SUBMERGED RESOURCES, SUCH AS CAVES, SHIP WRECKS OR REEFS, BOTH MAN-MADE OR NATURAL, TO ESTABLISH A BASELINE FOR FUTURE REFERENCE THAT CAN LATER INDICATE AN IMPROVEMENT OR DETERIORATION OF A PARTICULAR RESOURCE AND AID FUTURE CONSERVATION (U.S. CLS. 100, 101 AND 107).
FIRST USE 6-1-2010; IN COMMERCE 1-1-2011.

CLASS 41—(Continued).

4,016,940. FELE HOLDING CORPORATION, MIRAMAR, FL. SN 85-070,995. PUB. 10-12-2010, FILED 6-24-2010.

SKATELORDS

THE MARK CONSISTS OF STANDARD CHARACTERS WITHOUT CLAIM TO ANY PARTICULAR FONT, STYLE, SIZE, OR COLOR.

FOR ENTERTAINMENT SERVICES, NAMELY, PROVIDING ON-LINE COMPUTER GAMES (U.S. CLS. 100, 101 AND 107).

FIRST USE 7-27-2010; IN COMMERCE 7-27-2010.

4,016,961. FARRIS, ROY, AKA THE LEGENDS OF ROCK AND WRESTLING, GILBERT, AZ. SN 85-076,653. PUB. 3-22-2011, FILED 7-2-2010.

The Legends Of Rock And Wrestling

THE MARK CONSISTS OF STANDARD CHARACTERS WITHOUT CLAIM TO ANY PARTICULAR FONT, STYLE, SIZE, OR COLOR.

FOR ENTERTAINMENT IN THE NATURE OF LIVE PERFORMANCES BY A MUSICAL BAND CALLED THE LEGENDS OF ROCK AND WRESTLING (U.S. CLS. 100, 101 AND 107).

FIRST USE 5-14-2010; IN COMMERCE 5-14-2010.

4,016,963. LIVEYEARBOOK, INC., NEENAH, WI. SN 85-076,953. PUB. 11-30-2010, FILED 7-2-2010.

LIVEYEARBOOK

THE MARK CONSISTS OF STANDARD CHARACTERS WITHOUT CLAIM TO ANY PARTICULAR FONT, STYLE, SIZE, OR COLOR.

OWNER OF U.S. REG. NO. 2,985,066.

FOR PUBLICATION OF BOOKS, NAMELY, YEARBOOKS, REFERENCE BOOKS, DIRECTORIES, SCHOOL YEARBOOKS, ACTIVITY BOOKS AND MEMORY BOOKS (U.S. CLS. 100, 101 AND 107).

FIRST USE 11-30-2009; IN COMMERCE 2-5-2010.

CLASS 41—(Continued).

4,016,964. WEDORABLE LLC, STATEN ISLAND, NY. SN 85-077,074. PUB. 12-7-2010, FILED 7-2-2010.

WEDORABLE

THE MARK CONSISTS OF STANDARD CHARACTERS WITHOUT CLAIM TO ANY PARTICULAR FONT, STYLE, SIZE, OR COLOR.

FOR PARTY AND WEDDING PLANNING AND COORDINATION SERVICES; PARTY AND WEDDING PLANNING CONSULTATION SERVICES; WEDDING PLANNING AND COORDINATION SERVICES (U.S. CLS. 100, 101 AND 107).

FIRST USE 2-20-2011; IN COMMERCE 2-20-2011.

4,016,992. MASUCCI, MATIAS, LOS ANGELES, CA. SN 85-083,925. PUB. 3-1-2011, FILED 7-13-2010.

Independent Society

THE MARK CONSISTS OF STANDARD CHARACTERS WITHOUT CLAIM TO ANY PARTICULAR FONT, STYLE, SIZE, OR COLOR.

FOR BOOK PUBLISHING; DIGITAL VIDEO, AUDIO, AND MULTIMEDIA PUBLISHING SERVICES; MOTION PICTURE FILM PRODUCTION; MOVIE STUDIOS; MULTIMEDIA PUBLISHING OF BOOKS, MAGAZINES, JOURNALS, SOFTWARE, GAMES, MUSIC, AND ELECTRONIC PUBLICATIONS (U.S. CLS. 100, 101 AND 107).

FIRST USE 12-31-2003; IN COMMERCE 7-13-2010.

4,017,006. BRILL, WILLIAM, LITTLETON, CO. SN 85-088,094. PUB. 1-4-2011, FILED 7-19-2010.

FITNESS FOR CLASSICS

THE MARK CONSISTS OF STANDARD CHARACTERS WITHOUT CLAIM TO ANY PARTICULAR FONT, STYLE, SIZE, OR COLOR.

FOR EDUCATIONAL SERVICES, NAMELY, PROVIDING COGNITIVE FITNESS PROGRAMS FOR SENIORS; PROVIDING ASSISTANCE, PERSONAL TRAINING AND PHYSICAL FITNESS CONSULTATION TO INDIVIDUALS TO HELP THEM MAKE PHYSICAL FITNESS, STRENGTH, CONDITIONING, AND EXERCISE IMPROVEMENT IN THEIR DAILY LIVING (U.S. CLS. 100, 101 AND 107).

FIRST USE 8-18-2010; IN COMMERCE 9-6-2010.

CLASS 41—(Continued).

4,017,010. JACKSON HOLE MOUNTAIN RESORT CORPORATION, TETON VILLAGE, WY. SN 85-089,048. PUB. 1-11-2011, FILED 7-20-2010.

GRAND PASS

THE MARK CONSISTS OF STANDARD CHARACTERS WITHOUT CLAIM TO ANY PARTICULAR FONT, STYLE, SIZE, OR COLOR.

NO CLAIM IS MADE TO THE EXCLUSIVE RIGHT TO USE "PASS", APART FROM THE MARK AS SHOWN.

FOR SKI AND SNOWBOARD RESORT SERVICES (U.S. CLS. 100, 101 AND 107).

FIRST USE 7-1-2010; IN COMMERCE 7-1-2010.

4,017,044. TEACHERS' CURRICULUM INSTITUTE LLC, PALO ALTO, CA. SN 85-101,747. PUB. 12-7-2010, FILED 8-6-2010.

WORLD CULTURES ALIVE!

THE MARK CONSISTS OF STANDARD CHARACTERS WITHOUT CLAIM TO ANY PARTICULAR FONT, STYLE, SIZE, OR COLOR.

OWNER OF U.S. REG. NOS. 2,221,038, 3,398,587, AND OTHERS.

NO CLAIM IS MADE TO THE EXCLUSIVE RIGHT TO USE "WORLD CULTURES", APART FROM THE MARK AS SHOWN.

FOR EDUCATIONAL SERVICES, NAMELY, CONDUCTING WORKSHOPS, CLASSES, SEMINARS, AND CONFERENCES IN THE FIELD OF EDUCATOR TRAINING AND WORLD CULTURES; PROVIDING EDUCATIONAL COURSE TRAINING AND INSTRUCTIONAL COURSE INFORMATION IN THE FIELD OF WORLD CULTURES VIA A GLOBAL COMPUTER NETWORK; DEVELOPING EDUCATIONAL MANUALS IN THE FORM OF WEB MATERIALS AND ELECTRONIC DOCUMENTS FOR USE BY EDUCATORS AND TEACHERS IN THE FIELD OF WORLD CULTURES (U.S. CLS. 100, 101 AND 107).

FIRST USE 6-27-2011, THE MARK WAS FIRST USED ANYWHERE IN A DIFFERENT FORM OTHER THAN THAT SOUGHT TO BE REGISTERED AT LEAST AS EARLY AS 05/31/2002.; IN COMMERCE 6-27-2011, THE MARK WAS FIRST USED IN COMMERCE IN A DIFFERENT FORM OTHER THAN THAT SOUGHT TO BE REGISTERED AT LEAST AS EARLY AS 05/31/2002..

CLASS 41—(Continued).

4,017,069. CARTER, NETWAUN, WOODBRIDGE, VA. SN 85-109,292. PUB. 2-8-2011, FILED 8-17-2010.

BEING BLUNTLY HONEST

THE MARK CONSISTS OF STANDARD CHARACTERS WITHOUT CLAIM TO ANY PARTICULAR FONT, STYLE, SIZE, OR COLOR.

FOR ON-LINE JOURNALS, NAMELY, BLOGS FEATURING ENTERTAINMENT, NEWS, SPORTS, RELIGION, SEX, MUSIC, PUBLIC AND PERSONAL OPINION (U.S. CLS. 100, 101 AND 107).

FIRST USE 6-0-2011; IN COMMERCE 6-0-2011.

4,017,076. KABAM, INC., REDWOOD CITY, CA. SN 85-110,629. PUB. 2-8-2011, FILED 8-18-2010.

HERO FORCE

THE MARK CONSISTS OF STANDARD CHARACTERS WITHOUT CLAIM TO ANY PARTICULAR FONT, STYLE, SIZE, OR COLOR.

FOR ENTERTAINMENT SERVICES, NAMELY, PROVIDING TEMPORARY USE OF NON-DOWNLOADABLE ELECTRONIC GAMES (U.S. CLS. 100, 101 AND 107).

FIRST USE 11-18-2010; IN COMMERCE 11-18-2010.

4,017,100. THE BUSH FOUNDATION, MINNEAPOLIS, MN. SN 85-121,914. PUB. 3-1-2011, FILED 9-2-2010.

NEXT

Network for Excellence in Teaching

NO CLAIM IS MADE TO THE EXCLUSIVE RIGHT TO USE "NETWORK FOR EXCELLENCE IN TEACHING", APART FROM THE MARK AS SHOWN.

THE MARK CONSISTS OF THE STYLIZED TERM "NEXT" WITH A LOWER CASE "X" OVER THE PHRASE "NETWORK FOR EXCELLENCE IN TEACHING".

FOR EDUCATION SERVICES, NAMELY, PROVIDING PROGRAMS, TRAINING AND INSTRUCTION IN THE FIELD OF TEACHING AND EDUCATION (U.S. CLS. 100, 101 AND 107).

FIRST USE 5-31-2011; IN COMMERCE 5-31-2011.

CLASS 41—(Continued).

4,017,107. CROWDSTAR INTERNATIONAL LIMITED, BLACKROCK, CO. DUBLIN, IRELAND. SN 85-124,259. PUB. 3-22-2011, FILED 9-7-2010.

CROWDSTAR'S MIGHTY PIRATES

THE MARK CONSISTS OF STANDARD CHARACTERS WITHOUT CLAIM TO ANY PARTICULAR FONT, STYLE, SIZE, OR COLOR.

OWNER OF U.S. REG. NOS. 3,800,884 AND 3,885,298. FOR ENTERTAINMENT SERVICES, NAMELY, PROVIDING TEMPORARY USE OF NON-DOWNLOADABLE ELECTRONIC GAMES BY MEANS OF THE INTERNET OR OTHER WIRED OR WIRELESS NETWORKS (U.S. CLS. 100, 101 AND 107).

FIRST USE 10-0-2010; IN COMMERCE 10-0-2010.

4,017,110. ONE CONTINENT GROUP, LLC, LAS VEGAS, NV. SN 85-126,309. PUB. 2-8-2011, FILED 9-9-2010.

LUCYVEGAS.COM

THE MARK CONSISTS OF STANDARD CHARACTERS WITHOUT CLAIM TO ANY PARTICULAR FONT, STYLE, SIZE, OR COLOR.

FOR ARRANGING FOR TICKET RESERVATIONS, RESERVATIONS AND VIP PASSES FOR ENTERTAINMENT SHOWS, NIGHTCLUBS, GOLF GAMES AND OTHER ENTERTAINMENT EVENTS (U.S. CLS. 100, 101 AND 107).

FIRST USE 9-7-2010; IN COMMERCE 1-1-2011.

4,017,117. BOKWA FITNESS, SAN GABRIEL, CA. SN 85-129,465. PUB. 3-8-2011, FILED 9-14-2010.

BOKWA

THE MARK CONSISTS OF STANDARD CHARACTERS WITHOUT CLAIM TO ANY PARTICULAR FONT, STYLE, SIZE, OR COLOR.

FOR EDUCATIONAL SERVICES, NAMELY, PROVIDING CLASSES IN THE FIELD OF FITNESS COMPRISED OF DIFFERENT COMBINATIONS OF DANCING, CYCLING AND KICKBOXING FOR ALL AGES WITH THE USE OF LETTERS AND NUMBERS AS PLACEMENT AND DIRECTION OF MOVEMENT (U.S. CLS. 100, 101 AND 107).

FIRST USE 6-17-2000; IN COMMERCE 8-10-2008.

CLASS 41—(Continued).

4,017,119. LOFFLES, WILMINGTON, DE. SN 85-129,656. PUB. 3-8-2011, FILED 9-14-2010.

loffles

THE MARK CONSISTS OF STANDARD CHARACTERS WITHOUT CLAIM TO ANY PARTICULAR FONT, STYLE, SIZE, OR COLOR.

FOR SWEEPSTAKE SERVICES PROVIDED OVER A GLOBAL COMPUTER NETWORK (U.S. CLS. 100, 101 AND 107).

FIRST USE 3-15-2011; IN COMMERCE 6-27-2011.

4,017,124. TRANTER, EMMA, DELAND, FL. SN 85-130,957. PUB. 3-8-2011, FILED 9-16-2010.

PRECISION ALIGNMENT YOGA

THE MARK CONSISTS OF STANDARD CHARACTERS WITHOUT CLAIM TO ANY PARTICULAR FONT, STYLE, SIZE, OR COLOR.

NO CLAIM IS MADE TO THE EXCLUSIVE RIGHT TO USE "ALIGNMENT YOGA", APART FROM THE MARK AS SHOWN.

FOR YOGA INSTRUCTION SERVICES WITH SPECIFIC ALIGNMENT FOCUS (U.S. CLS. 100, 101 AND 107).

FIRST USE 10-1-2009; IN COMMERCE 1-1-2010.

4,017,150. HOTARU, INC., DBA FIREFLY, BEVERLY HILLS, CA. SN 85-148,772. PUB. 3-15-2011, FILED 10-8-2010.



OWNER OF U.S. REG. NOS. 3,787,023, 3,787,024, AND 3,787,026.

THE COLOR(S) BLACK IS/ARE CLAIMED AS A FEATURE OF THE MARK.

CLASS 41—(Continued).

THE MARK CONSISTS OF AN IMAGE OF A BLACK FLYING FIREFLY WITH FLAME AND SPARKS SHOOTING OUT BEHIND IT. THE COLOR WHITE IS BACKGROUND AND IS NOT CLAIMED AS A FEATURE OF THE MARK.

FOR DEVELOPMENT AND PRODUCTION OF LIVE THEATER AND PERFORMANCE EVENTS, NAMELY, PLAYS, MUSICALS, AND DANCE PERFORMANCES; THE DEVELOPMENT AND CREATION OF NARRATIVE MOTION PICTURES, ALL SPECIFICALLY EXCLUDING THE PROVISION OF FOR-HIRE PRODUCTION AND ANIMATION SERVICES (U.S. CLS. 100, 101 AND 107).

FIRST USE 9-19-2010; IN COMMERCE 4-1-2011.

4,017,167. AULT, JANET M, SCOTTSDALE, AZ. SN 85-155,936. PUB. 4-19-2011, FILED 10-19-2010.

THE AULT-ERNATIVE VOICE

THE MARK CONSISTS OF STANDARD CHARACTERS WITHOUT CLAIM TO ANY PARTICULAR FONT, STYLE, SIZE, OR COLOR.

NO CLAIM IS MADE TO THE EXCLUSIVE RIGHT TO USE "VOICE", APART FROM THE MARK AS SHOWN.

FOR PROVIDING VOICE OVER SERVICES, NAMELY, PROVIDING CHARACTER VOICES FOR TAPES, RECORDS AND OTHER RECORDED MEDIA FOR ENTERTAINMENT AND EDUCATION PURPOSES; PROVIDING VOICE OVER FOR RECORDINGS, VOICE MESSAGING, VOICE PROMPTING, RECORDED INTERACTIVE VOICE RESPONSES, VOICE OVER NARRATIONS, VOICE OVERS FOR CORPORATE VIDEO RECORDINGS, VOICE OVERS FOR AUDIO TOURS VIA TAPES, RECORDS AND OTHER RECORDED MEDIA FOR ENTERTAINMENT AND EDUCATION PURPOSES; PROVIDING VOICE IMAGING FOR RADIO, NAMELY, PROVIDING VOICE OVERS FOR TAPES, RECORDS, AND OTHER RECORDED MEDIA FOR ENTERTAINMENT AND EDUCATION PURPOSES; DUBBING; PROVIDING VOICE OVERS FOR TAPES, RECORDS, AND OTHER RECORDED MEDIA FOR ENTERTAINMENT AND EDUCATION PURPOSES (U.S. CLS. 100, 101 AND 107).

FIRST USE 5-24-2011; IN COMMERCE 5-24-2011.

4,017,174. LATEEF, NADYA, BERKELEY, CA. SN 85-159,490. PUB. 4-5-2011, FILED 10-22-2010.

Breaking Ground Productions

THE MARK CONSISTS OF STANDARD CHARACTERS WITHOUT CLAIM TO ANY PARTICULAR FONT, STYLE, SIZE, OR COLOR.

CLASS 41—(Continued).

NO CLAIM IS MADE TO THE EXCLUSIVE RIGHT TO USE "PRODUCTIONS", APART FROM THE MARK AS SHOWN.

FOR ENTERTAINMENT SERVICES, NAMELY, ARRANGING AND CONDUCTING SOCIAL ENTERTAINMENT EVENTS, CONCERTS, AND ENTERTAINMENT FASHION SHOWS (U.S. CLS. 100, 101 AND 107).

FIRST USE 2-1-2011; IN COMMERCE 2-1-2011.

4,017,185. MULTIPLEX PROPERTIES, INC., WILMINGTON, DE. SN 85-166,191. PUB. 3-29-2011, FILED 11-1-2010.

CINEMARK NEXTGEN

THE MARK CONSISTS OF STANDARD CHARACTERS WITHOUT CLAIM TO ANY PARTICULAR FONT, STYLE, SIZE, OR COLOR.

OWNER OF U.S. REG. NOS. 1,598,964, 2,390,388, AND OTHERS.

FOR MOVIE THEATER SERVICES (U.S. CLS. 100, 101 AND 107).

FIRST USE 11-0-2010; IN COMMERCE 11-0-2010.

4,017,231. SPEED CHANNEL, INC., LOS ANGELES, CA. SN 85-193,704. PUB. 5-10-2011, FILED 12-8-2010.

SPEEDMAKERS

THE MARK CONSISTS OF STANDARD CHARACTERS WITHOUT CLAIM TO ANY PARTICULAR FONT, STYLE, SIZE, OR COLOR.

OWNER OF U.S. REG. NOS. 2,780,662, 3,128,705, AND 3,302,139.

FOR ENTERTAINMENT SERVICES IN THE NATURE OF A TELEVISION SERIES FEATURING MOTORIZED VEHICLES AND MOTOR SPORTS; PROVIDING ONLINE INFORMATION IN THE FIELD OF TELEVISION AND VIDEO ENTERTAINMENT VIA THE INTERNET; ENTERTAINMENT SERVICES IN THE NATURE OF NON-DOWNLOADABLE VIDEOS AND IMAGES FEATURING TELEVISION SHOWS AND ENTERTAINMENT PERTAINING TO MOTORIZED VEHICLES AND MOTOR SPORTS TRANSMITTED VIA THE INTERNET AND WIRELESS COMMUNICATION NETWORKS (U.S. CLS. 100, 101 AND 107).

FIRST USE 2-24-2011; IN COMMERCE 2-24-2011.

CLASS 41—(Continued).

4,017,237. LIN, JONATHAN C., DBA ATIQTUQ, SAN RAFAEL, CA. SN 85-199,032. PUB. 5-10-2011, FILED 12-15-2010.



NO CLAIM IS MADE TO THE EXCLUSIVE RIGHT TO USE "MANGA", APART FROM THE MARK AS SHOWN. THE COLOR(S) ORANGE AND GREY IS/ARE CLAIMED AS A FEATURE OF THE MARK.

THE MARK CONSISTS OF A GREY FIST CLUTCHING AN ORANGE THUNDERBOLT, BOTH OF WHICH ARE POSITIONED ABOVE GRAY STYLIZED LETTERS THAT SPELL OUT "MANGA HERO".

FOR BOOK PUBLISHING; DIGITAL VIDEO, AUDIO, AND MULTIMEDIA PUBLISHING SERVICES; MULTIMEDIA PUBLISHING OF BOOKS, MAGAZINES, JOURNALS, SOFTWARE, GAMES, MUSIC, AND ELECTRONIC PUBLICATIONS; ONLINE ELECTRONIC PUBLISHING OF BOOKS AND PERIODICALS; PUBLISHING OF BOOKS, E-BOOKS, AUDIO BOOKS, MUSIC AND ILLUSTRATIONS; PUBLISHING OF BOOKS, MAGAZINES; PUBLISHING OF ELECTRONIC PUBLICATIONS; PUBLISHING OF WEB MAGAZINES (U.S. CLS. 100, 101 AND 107).

FIRST USE 1-15-2011; IN COMMERCE 7-1-2011.

4,017,239. SERVICE EXCELLENCE TRAINING, KYLE, TX. SN 85-202,262. PUB. 5-17-2011, FILED 12-20-2010.



NO CLAIM IS MADE TO THE EXCLUSIVE RIGHT TO USE "SERVICE EXCELLENCE TRAINING", APART FROM THE MARK AS SHOWN.

THE MARK CONSISTS OF A CIRCULAR SHIELD THAT HAS THE WORDS "SERVICE EXCELLENCE TRAINING" WRITTEN ON AN OUTER RING. THERE ARE TWO STARS THAT SEPARATE THE WORD "TRAINING" FROM THE WORDS "SERVICE EXCELLENCE". INSIDE THE INNER CIRCLE, THERE IS A LION WITH A SCROLL ABOVE HIS HEAD. THERE IS A WREATH THAT SURROUNDS THE LION.

FOR BUSINESS TRAINING CONSULTANCY SERVICES; TRAINING SERVICES IN THE FIELD OF RESIDENTIAL HOME REPAIR SERVICES (U.S. CLS. 100, 101 AND 107).

FIRST USE 11-23-2010; IN COMMERCE 11-26-2010.

CLASS 41—(Continued).

4,017,246. SPEED CHANNEL, INC., LOS ANGELES, CA. SN 85-214,474. PUB. 5-10-2011, FILED 1-10-2011.

CAR WARRIORS

THE MARK CONSISTS OF STANDARD CHARACTERS WITHOUT CLAIM TO ANY PARTICULAR FONT, STYLE, SIZE, OR COLOR.

NO CLAIM IS MADE TO THE EXCLUSIVE RIGHT TO USE "CAR", APART FROM THE MARK AS SHOWN.

FOR ENTERTAINMENT SERVICES IN THE NATURE OF A TELEVISION SERIES FEATURING AUTOMOBILES; PROVIDING ON-LINE INFORMATION IN THE FIELD OF TELEVISION AND VIDEO ENTERTAINMENT FEATURING AUTOMOBILES VIA THE INTERNET; ENTERTAINMENT SERVICES IN THE NATURE OF NON-DOWNLOADABLE VIDEOS AND IMAGES FEATURING TELEVISION SHOWS AND ENTERTAINMENT PERTAINING TO AUTOMOBILES AND MOTOR SPORTS TRANSMITTED VIA THE INTERNET AND WIRELESS COMMUNICATION NETWORKS (U.S. CLS. 100, 101 AND 107).

FIRST USE 2-23-2011; IN COMMERCE 2-23-2011.

4,017,249. BEHR PROCESS CORPORATION, SANTA ANA, CA. SN 85-227,311. PUB. 4-12-2011, FILED 1-27-2011.

BEHR YOUR COLORS

THE MARK CONSISTS OF STANDARD CHARACTERS WITHOUT CLAIM TO ANY PARTICULAR FONT, STYLE, SIZE, OR COLOR.

OWNER OF U.S. REG. NOS. 942,246, 1,551,547, AND OTHERS.

FOR ONLINE JOURNALS, NAMELY, BLOGS FEATURING PAINTING AND DECORATING ADVICE AND COMMENTARY (U.S. CLS. 100, 101 AND 107).

FIRST USE 5-19-2011; IN COMMERCE 5-19-2011.

4,017,252. IMPACT60 LEARNING SYSTEMS, LLC, STERLING, VA. SN 85-237,328. PUB. 5-10-2011, FILED 2-8-2011.

IMPACT60 Learning Systems

THE MARK CONSISTS OF STANDARD CHARACTERS WITHOUT CLAIM TO ANY PARTICULAR FONT, STYLE, SIZE, OR COLOR.

CLASS 41—(Continued).

NO CLAIM IS MADE TO THE EXCLUSIVE RIGHT TO USE "LEARNING SYSTEMS", APART FROM THE MARK AS SHOWN.

FOR EDUCATION SERVICES, NAMELY, PROVIDING BUSINESS TRAINING IN THE FIELD OF MANAGEMENT, LEADERSHIP, SALES AND CUSTOMER SERVICE TO CORPORATE AND GOVERNMENTAL CLIENTS (U.S. CLS. 100, 101 AND 107).

FIRST USE 8-31-2010; IN COMMERCE 5-1-2011.

4,017,253. IMPACT60 LEARNING SYSTEMS, LLC, STERLING, VA. SN 85-238,210. PUB. 5-10-2011, FILED 2-9-2011.

60 MINUTES for IMPACT

THE MARK CONSISTS OF STANDARD CHARACTERS WITHOUT CLAIM TO ANY PARTICULAR FONT, STYLE, SIZE, OR COLOR.

FOR EDUCATION SERVICES, NAMELY, PROVIDING BUSINESS TRAINING IN THE FIELD OF MANAGEMENT, LEADERSHIP, SALES AND CUSTOMER SERVICE TO CORPORATE AND GOVERNMENTAL CLIENTS (U.S. CLS. 100, 101 AND 107).

FIRST USE 10-1-2010; IN COMMERCE 5-1-2011.

4,017,254. PREFERRED COMMERCE, INC., WEST PALM BEACH, FL. SN 85-975,377. PUB. 10-19-2010, FILED 5-17-2010.

GROWUMS

THE MARK CONSISTS OF STANDARD CHARACTERS WITHOUT CLAIM TO ANY PARTICULAR FONT, STYLE, SIZE, OR COLOR.

FOR ENTERTAINMENT SERVICES, NAMELY, PROVIDING ONLINE VIDEO GAMES; INTERACTIVE EDUCATIONAL AND ENTERTAINMENT SERVICES, NAMELY, PROVIDING A WEB-BASED VIRTUAL EDUCATIONAL GARDEN (U.S. CLS. 100, 101 AND 107).

FIRST USE 1-4-2010; IN COMMERCE 1-4-2010.

CLASS 42—SCIENTIFIC AND COMPUTER SERVICES**CLASS 42—(Continued).**

4,016,184. REVIVA PHARMACEUTICALS, INC., SAN JOSE, CA. SN 77-166,973. PUB. 4-8-2008, FILED 4-26-2007.

REVIVA

THE MARK CONSISTS OF STANDARD CHARACTERS WITHOUT CLAIM TO ANY PARTICULAR FONT, STYLE, SIZE, OR COLOR.

FOR PHARMACEUTICAL DRUG RESEARCH AND DEVELOPMENT, INCLUDING CONDUCTING CLINICAL TRIALS AND CONSULTING SERVICES RELATED THERETO; PHARMACEUTICAL RESEARCH AND DEVELOPMENT SERVICES, NAMELY, DESIGNING, CONDUCTING AND MANAGING CLINICAL TRIALS AND REPORTING THE RESULTS OF SAME; PROVIDING ANALYSIS AND DESIGN SERVICES IN THE FIELD OF DRUG DEVELOPMENT AND CONDUCTING CLINICAL TRIALS OF NEWLY DEVELOPED DRUGS (U.S. CLS. 100 AND 101).

FIRST USE 12-0-2010; IN COMMERCE 12-0-2010.

4,016,227. ID ANALYTICS, INC., SAN DIEGO, CA. SN 77-347,243. PUB. 4-15-2008, FILED 12-7-2007.

'id:a

FOR APPLICATION SERVICE PROVIDER (ASP) FEATURING SOFTWARE IN THE FIELD OF IDENTITY FRAUD AND PROTECTION THEREFROM (U.S. CLS. 100 AND 101).

FIRST USE 12-0-2010; IN COMMERCE 12-0-2010.

CLASS 42—(Continued).

4,016,299. ADVENTIVE, INC., ROCHESTER, NY. SN 77-656,255. PUB. 10-26-2010, FILED 1-26-2009.



THE MARK CONSISTS OF THE WORD "ADVENTIVE" AND A DESIGN ELEMENT COMPRISED OF A TRIANGULAR SHAPE WITH ROUNDED CORNERS APPEARING BEHIND THE "AD" OF "ADVENTIVE".

FOR PROVIDING AN ON-LINE NON-DOWNLOADABLE SOFTWARE PLATFORM FOR CREATING, MANAGING, DISSEMINATING, AND MONITORING PERFORMANCE OF ADVERTISEMENTS IN THE FIELD OF E-COMMERCE SALES AND PROMOTIONS (U.S. CLS. 100 AND 101).

FIRST USE 4-0-2009; IN COMMERCE 4-0-2009.

4,016,301. BUILDMYPRODUCT.COM LLC, HAMPTON, VA. SN 77-664,913. PUB. 11-24-2009, FILED 2-6-2009.



NO CLAIM IS MADE TO THE EXCLUSIVE RIGHT TO USE "WWW" AND "INVENT" AND ".COM", APART FROM THE MARK AS SHOWN.

THE COLOR(S) BLUE, BLACK, YELLOW, GRAY AND WHITE IS/ARE CLAIMED AS A FEATURE OF THE MARK. THE MARK CONSISTS OF THE WORDING "WWW" IN BLACK LETTERING BELOW WHICH APPEARS THE WORDING "INVENT" IN BLUE LETTERING AND "NATION" IN BLACK LETTERING, WITH THE 'O' IN "NATION" APPEARING AS A BLACK AND WHITE GEAR DESIGN, WITH ".COM" APPEARING BELOW IN BLACK LETTERING; BEHIND THE WORDING "INVENT NATION" IS THE DESIGN OF A LIGHT BULB IN YELLOW, WHITE AND GRAY, ALL OF WHICH IS CONTAINED WITHIN A WHITE OVAL LINED IN BLACK.

FOR HOSTING AN ONLINE WEBSITE FEATURING INVENTORS RESOURCES (U.S. CLS. 100 AND 101).

FIRST USE 6-27-2011; IN COMMERCE 6-27-2011.

CLASS 42—(Continued).

4,016,309. BAEBLER, DREW,C., DBA THE GREEN CERTIFICATION CORPORATION, ST. LOUIS, MO. SN 77-685,699. PUB. 11-30-2010, FILED 3-6-2009.



NO CLAIM IS MADE TO THE EXCLUSIVE RIGHT TO USE "THE GREEN CERTIFICATION" AND "ECO-FRIENDLY CERTIFIED", APART FROM THE MARK AS SHOWN.

THE COLOR(S) BLUE AND GREEN IS/ARE CLAIMED AS A FEATURE OF THE MARK.

THE MARK CONSISTS OF THE FOLLOWING: A BLUE CIRCLE OUTLINED IN THE COLOR GREEN WITH GREEN ARROWS AROUND THE INSIDE RIM OF THE CIRCLE AND THE WORDING "THE GREEN CERTIFICATION" IN THE COLOR GREEN PLACED INSIDE THE CIRCLE AND THE WORDING "ECO-FRIENDLY CERTIFIED" IN THE COLOR BLUE PLACED BELOW THE CIRCLE.

FOR TESTING, ANALYSIS AND EVALUATION OF THE GOODS AND SERVICES OF OTHERS FOR THE PURPOSE OF CERTIFYING THAT THE GOODS AND SERVICES ARE GREEN AND ECO-FRIENDLY (U.S. CLS. 100 AND 101).

FIRST USE 3-13-1999; IN COMMERCE 5-9-2011.

4,016,316. TAWA PLC, LONDON, UNITED KINGDOM. SN 77-699,710. PUB. 2-16-2010, FILED 3-26-2009.

STRIPE

THE MARK CONSISTS OF STANDARD CHARACTERS WITHOUT CLAIM TO ANY PARTICULAR FONT, STYLE, SIZE, OR COLOR.

FOR PROVIDING TEMPORARY USE OF ON-LINE NON-DOWNLOADABLE SOFTWARE FOR USE AS A SHARED WORKFLOW, DOCUMENT REPOSITORY AND MESSAGING SERVICE FOR INSURANCE PURPOSES, BROKERAGE OF INSURANCE, BROKERAGE OF REINSURANCE, INSURANCE UNDERWRITING, CLAIMS HANDLING SERVICES, DATA PROCESSING, PROCESSING MARKET INFORMATION, AND FINANCIAL ANALYSIS (U.S. CLS. 100 AND 101).

FIRST USE 9-7-2010; IN COMMERCE 9-7-2010.

CLASS 42—(Continued).

4,016,374. BISHOP, KENNETH B., HERMOSA BEACH, CA. AND BISHOP, KJERSTI K, HERMOSA BEACH, CA. SN 77-786,863. PUB. 7-6-2010, FILED 7-22-2009.

Agent Noir

THE MARK CONSISTS OF STANDARD CHARACTERS WITHOUT CLAIM TO ANY PARTICULAR FONT, STYLE, SIZE, OR COLOR.

FOR DESIGN AND CREATION OF COMPUTER-MODELED VERSIONS OF HUMAN BEINGS USING COMPUTER ANIMATION FOR USE IN MOVIES, TELEVISION, INTERNET AND OTHER APPLICATIONS; DESIGN AND CREATION OF COMPUTER-MODELED VERSIONS OF HUMAN BEINGS USING COMPUTER ANIMATION FOR USE IN MOVIES, TELEVISION, INTERNET, GAMES AND OTHER APPLICATIONS; DESIGN AND DEVELOPMENT OF COMPUTER GAME SOFTWARE AND VIRTUAL REALITY SOFTWARE; DESIGNING AND DEVELOPING COMPUTER GAME SOFTWARE AND VIDEO GAME SOFTWARE FOR USE WITH COMPUTERS, VIDEO GAME PROGRAM SYSTEMS AND COMPUTER NETWORKS; DESIGNING AND MODIFYING COMPUTER PROGRAMS AND VIDEO GAMES FOR OTHERS; GRAPHIC ILLUSTRATION SERVICES FOR OTHERS; RESEARCH AND DEVELOPMENT OF 3D CONTENT, 3D TECHNOLOGY AND PROCESSES, STEREOSCOPIC 3D PROJECTION, 3D ANIMATION TECHNOLOGY, 3D PROCESSING POWER, 3D TECHNIQUES, AND FLEXIBLE FORWARD PROJECTION; ANIMATION AND SPECIAL-EFFECTS DESIGN FOR OTHERS; COMMERCIAL ART DESIGN; COMPUTER AIDED GRAPHIC DESIGN; COMPUTER MODELING SERVICES, NAMELY, COMPUTER SIMULATION FROM COMPUTER PROGRAMS FOR OTHERS; DESIGN OF CUSTOM PAINTINGS; DESIGN OF CUSTOMIZED BOOKS; GRAPHIC ART DESIGN; GRAPHIC ARTS DESIGNING; GRAPHIC DESIGN; GRAPHIC DESIGN SERVICES; MULTIDISCIPLINARY VISUAL DESIGN SERVICES; VISUAL DESIGN SERVICES IN THE NATURE OF DESIGNING VISUAL ELEMENTS FOR ONLINE, BROADCAST, PRINT, OUTDOOR AND OTHER COMMUNICATION MEDIA (U.S. CLS. 100 AND 101).
FIRST USE 5-20-2009; IN COMMERCE 6-22-2009.

4,016,390. ALEXANDER, JAMES M., CHAPPAQUA, NY. SN 77-813,085. PUB. 5-3-2011, FILED 8-26-2009.

VIZIBILITY

THE MARK CONSISTS OF STANDARD CHARACTERS WITHOUT CLAIM TO ANY PARTICULAR FONT, STYLE, SIZE, OR COLOR.

FOR PROVIDING TEMPORARY USE OF ONLINE, NONDOWNLOADABLE SOFTWARE FOR USE IN FORMULATING CUSTOM SEARCH QUERIES TO BE USED WITH SEARCH ENGINES (U.S. CLS. 100 AND 101).
FIRST USE 1-19-2010; IN COMMERCE 1-19-2010.

CLASS 42—(Continued).

4,016,440. AUBURN GLOBAL GROUP LLC, AUBURN HILLS, MI. SN 77-872,259. PUB. 10-12-2010, FILED 11-13-2009.

ACCESS 4 ARTISTS

THE MARK CONSISTS OF STANDARD CHARACTERS WITHOUT CLAIM TO ANY PARTICULAR FONT, STYLE, SIZE, OR COLOR.

FOR COMPUTERIZED ENTERTAINMENT SERVICES, NAMELY, CREATING AN ON-LINE COMMUNITY FOR REGISTERED USERS TO PARTICIPATE IN COMPETITIONS, SHOWCASE THEIR SKILLS AND TALENT IN THE MUSICAL, COMEDIC, AND PERFORMING ARTS, RECEIVE FEEDBACK FROM THEIR PEERS, FORM VIRTUAL COMMUNITIES, ENGAGE IN SOCIAL NETWORKING AND IMPROVE AND DEVELOP THEIR TALENT IN THE MUSICAL, COMEDIC, AND PERFORMING ARTS (U.S. CLS. 100 AND 101).
FIRST USE 12-31-2009; IN COMMERCE 12-31-2009.

4,016,441. INTELLIGENT MEDICAL OBJECTS, INC., NORTHBROOK, IL. SN 77-872,335. PUB. 11-9-2010, FILED 11-13-2009.

CODE SCOUT

THE MARK CONSISTS OF STANDARD CHARACTERS WITHOUT CLAIM TO ANY PARTICULAR FONT, STYLE, SIZE, OR COLOR.

NO CLAIM IS MADE TO THE EXCLUSIVE RIGHT TO USE "CODE", APART FROM THE MARK AS SHOWN.

FOR PROVIDING ONLINE NON-DOWNLOADABLE COMPUTER SOFTWARE FOR MANAGING MEDICAL TREATMENT FOR PATIENTS AND IN MAINTAINING MEDICAL RECORDS, THAT ENABLES USERS TO USE CROSSLINK MEDICAL VOCABULARY SUITES WITH COMMON SYNONYMS, ACRONYMS, PHRASES, AND LEXICAL VARIANTS AND PROVIDES SEARCH RESULTS CONTAINING RELATED TERMS, TEXTUAL DESCRIPTIONS, AND MAPS TO BILLING AND REFERENCE CODES (U.S. CLS. 100 AND 101).

FIRST USE 2-8-2010; IN COMMERCE 2-8-2010.

CLASS 42—(Continued).

4,016,512. KNOWLEDGEADVISORS, INC., CHICAGO, IL. SN 77-896,937. PUB. 11-2-2010, FILED 12-18-2009.

CHECK-IN TO CHANGE

THE MARK CONSISTS OF STANDARD CHARACTERS WITHOUT CLAIM TO ANY PARTICULAR FONT, STYLE, SIZE, OR COLOR.

FOR PROVIDING TEMPORARY USE OF A WEB BASED SOFTWARE APPLICATION THAT PROMOTES EMPLOYEE GOAL PLANNING, NAMELY, EMPLOYEE PRODUCTIVITY AND PERFORMANCE; PROVIDING A WEB SITE FEATURING TECHNOLOGY THAT ENABLES COMPANIES AND ORGANIZATIONS TO ADMINISTER AND MANAGE EMPLOYEE INCENTIVE AWARD PROGRAMS AND TO PROMOTE EMPLOYEE PRODUCTIVITY, PERFORMANCE, RECOGNITION AND MORALE IS CLASS TO PROMOTE AND FACILITATE EMPLOYEE PRODUCTIVITY, PERFORMANCE, RECOGNITION AND MORALE IS CLASS TO PROMOTE AND FACILITATE EMPLOYEE GOALS; APPLICATION SERVICE PROVIDER, NAMELY, PROVIDING WEB SITES OF OTHERS IN THE FIELDS OF EMPLOYEE PRODUCTIVITY TO PROMOTE EMPLOYEE GOALS (U.S. CLS. 100 AND 101).

FIRST USE 5-31-2010; IN COMMERCE 5-31-2010.

4,016,519. VIDACARE CORPORATION, SHAVANO PARK, TX. SN 77-901,307. PUB. 5-18-2010, FILED 12-28-2009.

DEFINING THE FIELD OF INTRAOSSEOUS MEDICINE

THE MARK CONSISTS OF STANDARD CHARACTERS WITHOUT CLAIM TO ANY PARTICULAR FONT, STYLE, SIZE, OR COLOR.

NO CLAIM IS MADE TO THE EXCLUSIVE RIGHT TO USE "THE FIELD OF INTRAOSSEOUS MEDICINE", APART FROM THE MARK AS SHOWN.

FOR DESIGN AND DEVELOPMENT OF EMERGENCY MEDICAL INSTRUMENTS AND DEVICES USED TO ACCESS BONE MARROW (U.S. CLS. 100 AND 101).

FIRST USE 11-18-2009; IN COMMERCE 12-10-2009.

CLASS 42—(Continued).

4,016,551. WEST PUBLISHING CORPORATION, EAGAN, MN. SN 77-918,143. PUB. 10-26-2010, FILED 1-22-2010.

WESTSEARCH

THE MARK CONSISTS OF STANDARD CHARACTERS WITHOUT CLAIM TO ANY PARTICULAR FONT, STYLE, SIZE, OR COLOR.

FOR COMPUTER SERVICES, NAMELY, PROVIDING AN ONLINE SEARCH ENGINE FOR CONDUCTING LEGAL RESEARCH (U.S. CLS. 100 AND 101).
FIRST USE 2-1-2010; IN COMMERCE 2-1-2010.

4,016,620. META PHARMACEUTICAL SERVICES, BLUE BELL, PA. SN 77-947,206. PUB. 11-2-2010, FILED 3-1-2010.

SAMPLEWIZARD

THE MARK CONSISTS OF STANDARD CHARACTERS WITHOUT CLAIM TO ANY PARTICULAR FONT, STYLE, SIZE, OR COLOR.

FOR PLATFORM AS A SERVICE (PAAS) FEATURING COMPUTER SOFTWARE PLATFORMS FOR ANALYZING AND TRACKING CORPORATE PROMOTIONAL ACTIVITIES AND PROFITABILITY, IDENTIFY AND RECOMMEND BEST BUSINESS PRACTICES, AND TO HELP BUSINESSES AVOID COMMON PITFALLS; RESEARCH ON THE SUBJECT OF PHARMACEUTICALS (U.S. CLS. 100 AND 101).

FIRST USE 7-8-2010; IN COMMERCE 7-8-2010.

4,016,647. JSPACE.COM, LLC, CHICAGO, IL. SN 77-959,516. PUB. 8-3-2010, FILED 3-15-2010.

Jspace

THE MARK CONSISTS OF STANDARD CHARACTERS WITHOUT CLAIM TO ANY PARTICULAR FONT, STYLE, SIZE, OR COLOR.

FOR COMPUTER SERVICES, NAMELY, PROVIDING A WEB-BASED SYSTEM AND ONLINE PORTAL FOR CUSTOMERS TO REMOTELY MANAGE, ADMINISTER, MODIFY AND CONTROL THEIR END USER COMPUTER DEVICES, DATA AND SOFTWARE APPLICATIONS (U.S. CLS. 100 AND 101).

FIRST USE 8-14-2006; IN COMMERCE 8-14-2006.

CLASS 42—(Continued).

4,016,711. SCIULLI DIGITAL MEDIA GROUP, INC., MILL VALLEY, CA. SN 77-982,341. PUB. 11-23-2010, FILED 1-25-2010.

IMAGERCISE

THE MARK CONSISTS OF STANDARD CHARACTERS WITHOUT CLAIM TO ANY PARTICULAR FONT, STYLE, SIZE, OR COLOR.

FOR NEUROFEEDBACK TECHNOLOGY SERVICES, NAMELY, PROVIDING ON-LINE NON-DOWNLOADABLE SOFTWARE FOR FACILITATING NEUROFEEDBACK ASSISTED HYPNOSIS AND MEDITATION (U.S. CLS. 100 AND 101).

FIRST USE 12-29-2010; IN COMMERCE 3-29-2011.

4,016,724. ENVIRONMENTAL SCIENCE SERVICES, INC., DENHAM SPRINGS, LA. SN 85-001,155. PUB. 1-25-2011, FILED 3-29-2010.

OREGIS

THE MARK CONSISTS OF STANDARD CHARACTERS WITHOUT CLAIM TO ANY PARTICULAR FONT, STYLE, SIZE, OR COLOR.

FOR APPLICATION SERVICE PROVIDER (ASP) FEATURING SOFTWARE TO ASSIST WITH THE COMPILATION AND PREPARATION OF ENVIRONMENTAL OPERATIONAL RESPONSE PLANNING, NAMELY, ACCESSING COMPILED DATA IN THE FIELDS OF MAPPING, ENVIRONMENTAL, LOGISTICAL, SOCIO-ECONOMIC, RESPONSE, OIL AND GAS, HYDROLOGIC AND REGULATORY (U.S. CLS. 100 AND 101).

FIRST USE 1-1-2010; IN COMMERCE 1-1-2010.

4,016,752. A/V MARKETING, INC., DBA GISH TECHNOLOGY, INC., INDIANAPOLIS, IN. SN 85-013,402. PUB. 11-9-2010, FILED 4-14-2010.

GISH INDEX

THE MARK CONSISTS OF STANDARD CHARACTERS WITHOUT CLAIM TO ANY PARTICULAR FONT, STYLE, SIZE, OR COLOR.

FOR VISUAL ACUITY DETERMINATION SERVICES, NAMELY, ANALYSIS AND EVALUATION OF CAMERA LENS TO DETERMINE CLARITY OF IMAGES, FOR USE IN VIDEO SURVEILLANCE (U.S. CLS. 100 AND 101).

FIRST USE 6-23-2011; IN COMMERCE 6-23-2011.

CLASS 42—(Continued).

4,016,794. 1 WALPOLE STREET, NORWOOD, MA. SN 85-034,169. PUB. 10-12-2010, FILED 5-10-2010.

CLONESAT

THE MARK CONSISTS OF THE STYLIZED TEXT "CLONE SAT".

FOR PROVIDING A SERVICE THAT DUPLICATES RETAIL WEBSITES SO THAT THEY CAN BE CENTRALLY CONTROLLED BY HEAD OFFICE AND RECOGNIZED BY SEARCH ENGINES AS LOCAL ENTITIES (U.S. CLS. 100 AND 101).

FIRST USE 7-7-2008; IN COMMERCE 10-17-2008.

4,016,805. SELMONT, GEORGE A., MIDDLE HADDAM, CT. SN 85-037,422. PUB. 10-19-2010, FILED 5-13-2010.

PXP

THE MARK CONSISTS OF STANDARD CHARACTERS WITHOUT CLAIM TO ANY PARTICULAR FONT, STYLE, SIZE, OR COLOR.

FOR HOSTING A WEBSITE PROVIDING NON-DOWNLOADABLE COMPUTER SOFTWARE FOR UPLOADING, DOWNLOADING, MANAGING, MANIPULATING, AUTHORING, CAPTURING, COMPILING, CREATING, SHARING, DISTRIBUTING, EDITING, HOSTING, PROCESSING, PRODUCING, RECORDING, AND ONLINE VIEWING OF USER GENERATED DIGITAL MULTIMEDIA CONTENT RELATED TO ENTERTAINMENT AND SPORTING EVENTS INCLUDING DIGITAL AUDIO, VIDEO, TEXT AND GRAPHIC CONTENT VIA NON-DOWNLOADABLE SERVER-CLIENT IMAGE STREAMING AND DISTRIBUTION SOFTWARE (U.S. CLS. 100 AND 101).

FIRST USE 2-5-2010; IN COMMERCE 5-5-2011.

4,016,808. RE FORMSNET, LLC, DBA ZIPLOGIX, LOS ANGELES, CA. SN 85-038,088. PUB. 4-26-2011, FILED 5-13-2010.

ZIPLOGIX DIGITAL INK

THE MARK CONSISTS OF STANDARD CHARACTERS WITHOUT CLAIM TO ANY PARTICULAR FONT, STYLE, SIZE, OR COLOR.

CLASS 42—(Continued).

NO CLAIM IS MADE TO THE EXCLUSIVE RIGHT TO USE "DIGITAL", APART FROM THE MARK AS SHOWN.

FOR PROVIDING TEMPORARY USE OF ON-LINE NON-DOWNLOADABLE SOFTWARE FOR SECURE EXECUTION, TRANSMISSION AND STORAGE OF ELECTRONIC SIGNATURES AND ELECTRONIC RECORDS IN THE REAL ESTATE INDUSTRY (U.S. CLS. 100 AND 101).

FIRST USE 5-15-2010; IN COMMERCE 5-15-2010.

4,016,813. SYSCO CORPORATION, HOUSTON, TX. SN 85-039,898. PUB. 10-19-2010, FILED 5-17-2010.

NETIMPAC

THE MARK CONSISTS OF STANDARD CHARACTERS WITHOUT CLAIM TO ANY PARTICULAR FONT, STYLE, SIZE, OR COLOR.

OWNER OF U.S. REG. NO. 1,832,481.

FOR APPLICATION SERVICE PROVIDER (ASP) FEATURING SOFTWARE FOR USE IN PROVIDING MENUS, RECIPES, NUTRITIONAL ANALYSIS AND DIETARY MANAGEMENT REPORTS (U.S. CLS. 100 AND 101).

FIRST USE 8-1-2010; IN COMMERCE 8-1-2010.

4,016,816. BEIJING UPLOOKING TECHNOLOGY CO., LTD., HAIJIAN DIS., BEIJING, CHINA. SN 85-040,998. PUB. 12-21-2010, FILED 5-18-2010.

uplooking

THE MARK CONSISTS OF ROMAN LETTERS OF "UPLOOKING".

FOR TECHNICAL PROJECT STUDIES IN THE NATURE OF CONDUCTING FEASIBILITY STUDIES; RESEARCH AND DEVELOPMENT OF COMPUTER SOFTWARE; COMPUTER RENTAL; COMPUTER PROGRAMMING; COMPUTER SOFTWARE DESIGN; UPDATING OF COMPUTER SOFTWARE; CREATING AND MAINTAINING WEB SITES FOR OTHERS; HOSTING COMPUTER SITES, NAMELY, WEB SITES; INSTALLATION OF COMPUTER SOFTWARE; COMPUTER SYSTEM DESIGN (U.S. CLS. 100 AND 101).

FIRST USE 10-26-2006; IN COMMERCE 6-8-2009.

CLASS 42—(Continued).

4,016,829. UTOPIC, LLC, CHICAGO, IL. SN 85-044,030. PUB. 10-26-2010, FILED 5-20-2010.



THE MARK CONSISTS OF A SHADED SMALLER CIRCLE SURROUNDED BY A RING CIRCLE SURROUNDED BY A THICKER OUTSIDE CIRCULAR SHAPED LINED RING WITH TWO NOTCHES EXTENDING OUT DIRECTLY ACROSS FROM EACH OTHER, AND FEATURING TWO BREAKS IN THE RING THAT ARE LOCATED DIRECTLY OPPOSITE EACH OTHER AT 90 DEGREE ANGLES FROM THE NOTCHES.

FOR ANIMATION AND SPECIAL-EFFECTS DESIGN FOR OTHERS; BUILDING AND MAINTAINING WEBSITES; DESIGN OF HOME PAGES AND WEB SITES; DESIGNING WEBSITES FOR ADVERTISING PURPOSES; GRAPHIC ARTS DESIGNING; GRAPHIC DESIGN SERVICES; MULTIDISCIPLINARY GRAPHIC DESIGN SERVICES; UPDATING WEBSITES FOR OTHERS; WEBSITE DEVELOPMENT FOR OTHERS (U.S. CLS. 100 AND 101).

FIRST USE 11-1-2009; IN COMMERCE 11-1-2009.

4,016,872. RIEDELL SHOES, INC., RED WING, MN. SN 85-055,848. PUB. 10-26-2010, FILED 6-7-2010.

Riedell Color Lab

THE MARK CONSISTS OF STANDARD CHARACTERS WITHOUT CLAIM TO ANY PARTICULAR FONT, STYLE, SIZE, OR COLOR.

OWNER OF U.S. REG. NOS. 505,196 AND 3,813,071.

NO CLAIM IS MADE TO THE EXCLUSIVE RIGHT TO USE "COLOR LAB", APART FROM THE MARK AS SHOWN.

SEC. 2(F) AS TO "RIEDEL".

FOR ONLINE CUSTOM SKATE BOOT DESIGN SERVICE, ENABLING USERS TO DESIGN AND ORDER SKATE BOOTS CUSTOMIZED TO PERSONAL SELECTION OF COLORS AND CERTAIN BOOT COMPONENTS (U.S. CLS. 100 AND 101).

FIRST USE 5-2-2011; IN COMMERCE 5-2-2011.

CLASS 42—(Continued).

4,016,873. RIEDELL SHOES, INC., RED WING, MN. SN 85-055,851. PUB. 11-2-2010, FILED 6-7-2010.

Riedell My Skate

THE MARK CONSISTS OF STANDARD CHARACTERS WITHOUT CLAIM TO ANY PARTICULAR FONT, STYLE, SIZE, OR COLOR.

OWNER OF U.S. REG. NOS. 505,196 AND 3,813,071.

NO CLAIM IS MADE TO THE EXCLUSIVE RIGHT TO USE "SKATE", APART FROM THE MARK AS SHOWN.

FOR ONLINE CUSTOM SKATE BOOT DESIGN SERVICE, ENABLING USERS TO ORDER ROLLER SKATES CUSTOMIZED TO PERSONAL SELECTION BY PAIRING SELECTED BOOTS WITH CERTAIN BOOT COMPONENTS (U.S. CLS. 100 AND 101).

FIRST USE 5-1-2010; IN COMMERCE 5-1-2010.

CLASS 42—(Continued).

4,016,903. ACCREDITATION COUNCIL FOR BUSINESS SCHOOLS AND PROGRAMS, AKA ACBSP, OVERLAND PARK, KS. SN 85-064,624. PUB. 1-11-2011, FILED 6-16-2010.



NO CLAIM IS MADE TO THE EXCLUSIVE RIGHT TO USE "GLOBAL BUSINESS ACCREDITATION", APART FROM THE MARK AS SHOWN.

FOR ACCREDITATION SERVICES, NAMELY, EVALUATING ORGANIZATIONS TO DETERMINE WHETHER THE ORGANIZATIONS CONFORM TO AN ESTABLISHED STANDARD FOR TEACHING EXCELLENCE IN THE FIELD OF BUSINESS (U.S. CLS. 100 AND 101).

FIRST USE 7-1-2010; IN COMMERCE 7-1-2010.

4,016,895. C. KIRIN CHRISTIANSON, SCOTTSDALE, AZ. SN 85-061,938. PUB. 11-9-2010, FILED 6-14-2010.

UNITED IN GLAM

THE MARK CONSISTS OF STANDARD CHARACTERS WITHOUT CLAIM TO ANY PARTICULAR FONT, STYLE, SIZE, OR COLOR.

FOR COMPUTER SERVICES, NAMELY, CREATING AN ON-LINE COMMUNITY FOR REGISTERED USERS TO PARTICIPATE IN A VIRTUAL MODELING SCHOOL OF HOW-TO CLASSES, GET FEEDBACK FROM THEIR PEERS, AND DISCUSSIONS RELATING TO FASHION, BEAUTIFUL AND FITNESS FOR MOTHERS (U.S. CLS. 100 AND 101).

FIRST USE 10-15-2010; IN COMMERCE 10-15-2010.

4,016,909. ECOMMERCE INDUSTRIES, INC., LEESBURG, VA. SN 85-066,263. PUB. 11-16-2010, FILED 6-18-2010.

ECINTELLIGENCE

4,016,900. KAINEXUS LLC, DALLAS, TX. SN 85-063,992. PUB. 11-16-2010, FILED 6-16-2010.

KaiNexus

THE MARK CONSISTS OF STANDARD CHARACTERS WITHOUT CLAIM TO ANY PARTICULAR FONT, STYLE, SIZE, OR COLOR.

FOR SOFTWARE AS A SERVICE TO IMPLEMENT A CONTINUOUS QUALITY IMPROVEMENT PROGRAM AT AN ORGANIZATION (U.S. CLS. 100 AND 101).

FIRST USE 5-14-2010; IN COMMERCE 12-20-2010.

THE MARK CONSISTS OF STANDARD CHARACTERS WITHOUT CLAIM TO ANY PARTICULAR FONT, STYLE, SIZE, OR COLOR.

FOR PROVIDING TEMPORARY USE OF ONLINE NON-DOWNLOADABLE SOFTWARE THAT ENABLES MANUFACTURERS AND WHOLESALERS TO TRACK THE PURCHASE AND ORDERS OF PRODUCTS IN THE FIELDS OF LUMBER AND BUILDING MATERIALS, OFFICE PRODUCTS, OFFICE MACHINES AND EQUIPMENT, OFFICE FURNITURE, SCHOOL SUPPLIES, FARM AND RANCH SUPPLIES, PROPANE AND GAS, WATER AND COFFEE, JANITORIAL AND INDUSTRIAL PAPER, HARDLINES, HARDWARE AND HOME PRODUCTS, PAINTING AND DECORATING, HVAC, PLUMBING AND ELECTRICAL, AND INFORMATION STORING AND DESTRUCTION (U.S. CLS. 100 AND 101).

FIRST USE 5-0-2011; IN COMMERCE 5-0-2011.

CLASS 42—(Continued).

4,016,913. MEDICAL DIAGNOSTIC LABORATORIES, LLC, HAMILTON, NJ. SN 85-066,364. PUB. 11-16-2010, FILED 6-18-2010.



NO CLAIM IS MADE TO THE EXCLUSIVE RIGHT TO USE "CANCER RESEARCH CENTER" AND THE IMAGE OF A TUMOR CELL, APART FROM THE MARK AS SHOWN.

THE COLOR(S) GOLD, BLUE-GREEN AND BROWN IS/ ARE CLAIMED AS A FEATURE OF THE MARK.

THE MARK CONSISTS OF THE LITERAL ELEMENTS "ONCOVEDA" DEPICTED IN UPPER-CASE LETTERS AND "CANCER RESEARCH CENTER" DEPICTED IN UPPER-CASE LETTERS. THE LETTERS "ONCO" IN THE WORD "ONCOVEDA" ARE DEPICTED IN GOLD. THE LETTERS "VEDA" IN THE WORD "ONCOVEDA" ARE DEPICTED IN BLUE-GREEN. THE LETTER "V" IN THE WORD "ONCOVEDA" IS DEPICTED IN A SLIGHTLY LARGER FONT SIZE THAN THE REMAINING LETTERS IN THE WORD "ONCOVEDA". THE PHRASE "CANCER RESEARCH CENTER" IS DEPICTED IN BLUE-GREEN BENEATH THE LETTERS "ONCO" IN THE WORD "ONCOVEDA" IN A FONT SIZE SMALLER THAN THE WORD "ONCOVEDA". EIGHT (8) CIRCLES ARE DEPICTED FORMING A SEMI-CIRCLE TO THE RIGHT OF THE LITERAL ELEMENTS "ONCOVEDA" AND "CANCER RESEARCH CENTER". THE CIRCLES DEPICTED FORMING THE SEMI-CIRCLE GRADUALLY INCREASE IN CIRCUMFERENCE BEGINNING WITH THE SMALLEST CIRCLE DEPICTED ABOVE AND TO THE RIGHT OF THE LETTER "V" IN THE WORD "ONCOVEDA" AND ENDING WITH THE LARGEST CIRCLE DEPICTED BELOW THE LETTER "E" IN THE WORD "ONCOVEDA". THE CIRCLES DEPICTED FORMING THE SEMI-CIRCLE GRADUALLY BECOME MORE FILAMENTED AS THE CIRCLES INCREASE IN CIRCUMFERENCE. THE CIRCLES DEPICTED FORMING THE SEMI-CIRCLE GRADUALLY CHANGE COLOR FROM BLUE-GREEN (SMALLEST CIRCLE) TO GOLD (LARGEST CIRCLE). A TUMOR CELL IS DEPICTED BENEATH THE LETTER "V" IN THE WORD "ONCOVEDA" AND TO THE LEFT OF THE LARGEST CIRCLE AT THE END OF THE SEMI-CIRCLE. THE TUMOR CELL IS DEPICTED IN BROWN. BROWN FILAMENTS ARE DEPICTED RADIATING FROM THE TUMOR CELL.

FOR RESEARCH AND DEVELOPMENT IN THE PHARMACEUTICAL AND BIOTECHNOLOGY FIELDS (U.S. CLS. 100 AND 101).

FIRST USE 4-28-2010; IN COMMERCE 6-17-2010.

CLASS 42—(Continued).

4,016,995. CAROLINA EAR & HEARING CLINIC, PC, RALEIGH, NC. SN 85-085,081. PUB. 3-22-2011, FILED 7-15-2010.

VERIFY

THE MARK CONSISTS OF STANDARD CHARACTERS WITHOUT CLAIM TO ANY PARTICULAR FONT, STYLE, SIZE, OR COLOR.

FOR REMOTE DIAGNOSIS OF MEDICAL MONITORING EQUIPMENT VIA GLOBAL COMPUTER NETWORKS AND TELECOMMUNICATIONS SYSTEMS FOR DETERMINING THE FUNCTION AND PERFORMANCE OF EQUIPMENT AND WHETHER ADJUSTMENT, CALIBRATION, MODIFICATION OR MAINTENANCE IS NEEDED; CALIBRATION OF MEDICAL MONITORING EQUIPMENT (U.S. CLS. 100 AND 101).

FIRST USE 2-18-2011; IN COMMERCE 2-18-2011.

4,017,005. HUMANA INC., LOUISVILLE, KY. SN 85-087,793. PUB. 11-23-2010, FILED 7-19-2010.

PLAY LIFE WELL

THE MARK CONSISTS OF STANDARD CHARACTERS WITHOUT CLAIM TO ANY PARTICULAR FONT, STYLE, SIZE, OR COLOR.

FOR COMPUTER SERVICES, NAMELY, HOSTING AN ON-LINE VIRTUAL ENVIRONMENT; COMPUTER SERVICES, NAMELY, HOSTING AN ON-LINE VIRTUAL ENVIRONMENT FEATURING THEMES OF HEALTH, WELLNESS, HEALTHY LIFESTYLES, PHYSICAL FITNESS, NUTRITION, AND EXERCISE (U.S. CLS. 100 AND 101).

FIRST USE 7-0-2010; IN COMMERCE 7-0-2010.

4,017,054. BAMBOO SOLUTIONS CORPORATION, RESTON, VA. SN 85-105,121. PUB. 11-16-2010, FILED 8-11-2010.

BAMBOOCR™

THE MARK CONSISTS OF STANDARD CHARACTERS WITHOUT CLAIM TO ANY PARTICULAR FONT, STYLE, SIZE, OR COLOR.

FOR PROVIDING SOFTWARE AS A SERVICE (SAAS) FEATURING ENTERPRISE INFORMATION MANAGEMENT SOFTWARE (U.S. CLS. 100 AND 101).

FIRST USE 9-29-2010; IN COMMERCE 2-17-2011.

CLASS 42—(Continued).

4,017,079. JOHN M. CAMPBELL CONSULTING, LLC, NORMAN, OK. SN 85-111,979. PUB. 2-1-2011, FILED 8-20-2010.

JMCC

THE MARK CONSISTS OF STANDARD CHARACTERS WITHOUT CLAIM TO ANY PARTICULAR FONT, STYLE, SIZE, OR COLOR.

FOR ENGINEERING SERVICES, NAMELY, ENGINEERING FOR THE OIL AND NATURAL GAS INDUSTRY (U.S. CLS. 100 AND 101).

FIRST USE 12-1-2010; IN COMMERCE 12-1-2010.

4,017,097. JOINGO LLC, SAN JOSE, CA. SN 85-119,126. PUB. 3-8-2011, FILED 8-30-2010.



mobilemoney

THE MARK CONSISTS OF A STYLIZED CELL PHONE DESIGN WITH A "\$" IN THE MIDDLE. THE TEXT "MOBILEMONEY" APPEARS TO THE RIGHT OF THE DESIGN.

FOR SOFTWARE AS A SERVICE (SAAS) SERVICES, NAMELY, HOSTING SOFTWARE FOR USE BY OTHERS FOR USE AS MARKETING PROGRAM WITH REWARDS FOR VIEWING THE MARKETING CONTENT AND INTERACTING WITH THE SERVICES (U.S. CLS. 100 AND 101).

FIRST USE 3-30-2010; IN COMMERCE 3-30-2010.

4,017,116. HOLDEN SHEN, LLC, CHICAGO, IL. SN 85-129,324. PUB. 3-15-2011, FILED 9-14-2010.

KOOWIE

THE MARK CONSISTS OF STANDARD CHARACTERS WITHOUT CLAIM TO ANY PARTICULAR FONT, STYLE, SIZE, OR COLOR.

FOR COMPUTER SERVICES, NAMELY, CREATING AN ON-LINE COMMUNITY FOR REGISTERED USERS TO PARTICIPATE IN DISCUSSIONS, GET FEEDBACK FROM THEIR PEERS, FORM VIRTUAL COMMUNITIES, PUBLISH THEIR THOUGHTS AND ENGAGE IN SOCIAL NETWORKING; COMPUTER SERVICES, NAMELY, PROVIDING SEARCH ENGINES ON A GLOBAL COMPUTER NETWORK FOR SEARCHING THROUGH ON-LINE TEXT PUBLISHED BY REGISTERED USERS OF ON-LINE COMMUNITY (U.S. CLS. 100 AND 101).

FIRST USE 8-1-2010; IN COMMERCE 10-1-2010.

CLASS 42—(Continued).

4,017,160. MISSOURI HOSPITAL ASSOCIATION, JEFFERSON CITY, MO. SN 85-152,490. PUB. 5-10-2011, FILED 10-14-2010.

EHRASSIST

THE MARK CONSISTS OF STANDARD CHARACTERS WITHOUT CLAIM TO ANY PARTICULAR FONT, STYLE, SIZE, OR COLOR.

FOR PROVIDING A WEBSITE FEATURING TECHNOLOGY THAT ALLOWS HOSPITALS TO SELECT, IDENTIFY, AND ENGAGE VENDORS TO RENDER TECHNICAL SERVICES, ASSISTANCE, AND CONSULTATION RELATED TO THE IMPLEMENTATION, OPERATION, MANAGEMENT, REPAIR, AND OPTIMIZATION OF ELECTRONIC HEALTH RECORD SYSTEMS (U.S. CLS. 100 AND 101).

FIRST USE 7-6-2011; IN COMMERCE 7-6-2011.

4,017,169. CHI MEDIA GROUP, LLC, LAS VEGAS, NV. SN 85-156,279. PUB. 3-22-2011, FILED 10-19-2010.

JUST CAN'T HANDLE

THE MARK CONSISTS OF STANDARD CHARACTERS WITHOUT CLAIM TO ANY PARTICULAR FONT, STYLE, SIZE, OR COLOR.

FOR PROVIDING A WEB SITE THAT GIVES COMPUTER USERS THE ABILITY TO UPLOAD, EXCHANGE AND SHARE PHOTOS, VIDEOS AND VIDEO LOGS; PROVIDING A WEBSITE THAT GIVES COMPUTER USERS THE ABILITY TO VIEW, UPLOAD, POST, DISPLAY, TAG, AND SHARE USER-GENERATED AUDIO CLIPS, VIDEO CLIPS, PHOTOGRAPHS, AND WRITTEN MATERIAL ON A WIDE VARIETY OF TOPICS AND SUBJECTS (U.S. CLS. 100 AND 101).

FIRST USE 1-0-2011; IN COMMERCE 1-0-2011.

4,017,191. END GAMES ENTERTAINMENT, LLC, BROOMFIELD, CO. SN 85-168,443. PUB. 4-12-2011, FILED 11-3-2010.

END GAMES ENTERTAINMENT

THE MARK CONSISTS OF STANDARD CHARACTERS WITHOUT CLAIM TO ANY PARTICULAR FONT, STYLE, SIZE, OR COLOR.

CLASS 42—(Continued).

NO CLAIM IS MADE TO THE EXCLUSIVE RIGHT TO USE "GAMES ENTERTAINMENT", APART FROM THE MARK AS SHOWN.

FOR DESIGN AND DEVELOPMENT OF COMPUTER SOFTWARE; DESIGNING AND DEVELOPING COMPUTER GAME SOFTWARE AND VIDEO GAME SOFTWARE FOR USE WITH COMPUTERS, VIDEO GAME PROGRAM SYSTEMS AND COMPUTER NETWORKS; DESIGNING AND MODIFYING COMPUTER PROGRAMS AND VIDEO GAMES FOR OTHERS (U.S. CLS. 100 AND 101).

FIRST USE 11-15-2010; IN COMMERCE 11-15-2010.

CLASS 43—(Continued).

4,016,431. B HOTEL GROUP, LLC, WESTON, FL. SN 77-867,202. PUB. 4-13-2010, FILED 11-6-2009.

B DOWNTOWN

THE MARK CONSISTS OF STANDARD CHARACTERS WITHOUT CLAIM TO ANY PARTICULAR FONT, STYLE, SIZE, OR COLOR.

FOR HOTEL, RESORT LODGING AND MOTEL SERVICES; RESTAURANT, CATERING, BAR AND COCKTAIL LOUNGE SERVICES; PROVISION OF GENERAL PURPOSE FACILITIES FOR MEETINGS, CONFERENCES AND EXHIBITIONS; PROVISION OF BANQUET AND SOCIAL FUNCTION FACILITIES FOR SPECIAL OCCASIONS; HOTEL SERVICES FOR PREFERRED CUSTOMERS; SPA SERVICES, NAMELY, PROVIDING TEMPORARY ACCOMMODATIONS AND MEALS TO CLIENTS OF A HEALTH OR BEAUTY SPA; AND RESERVATION SERVICES FOR HOTEL ACCOMMODATIONS FOR OTHERS (U.S. CLS. 100 AND 101).

FIRST USE 9-23-2010; IN COMMERCE 9-23-2010.

4,017,218. ADJUTANT IT, WALNUT CREEK, CA. SN 85-182,430. PUB. 4-26-2011, FILED 11-22-2010.



4,016,432. B HOTEL GROUP, LLC, WESTON, FL. SN 77-867,245. PUB. 4-13-2010, FILED 11-6-2009.

B IN THE CITY

NO CLAIM IS MADE TO THE EXCLUSIVE RIGHT TO USE "IT", APART FROM THE MARK AS SHOWN.

THE MARK CONSISTS OF THE STYLIZED LETTERS "IT" INSIDE AN @ SYMBOL.

FOR IT CONSULTING SERVICES SPECIALIZING IN IT INFRASTRUCTURE (U.S. CLS. 100 AND 101).

FIRST USE 10-1-2010; IN COMMERCE 3-1-2011.

THE MARK CONSISTS OF STANDARD CHARACTERS WITHOUT CLAIM TO ANY PARTICULAR FONT, STYLE, SIZE, OR COLOR.

FOR HOTEL, RESORT LODGING AND MOTEL SERVICES; RESTAURANT, CATERING, BAR AND COCKTAIL LOUNGE SERVICES; PROVISION OF GENERAL PURPOSE FACILITIES FOR MEETINGS, CONFERENCES AND EXHIBITIONS; PROVISION OF BANQUET AND SOCIAL FUNCTION FACILITIES FOR SPECIAL OCCASIONS; HOTEL SERVICES FOR PREFERRED CUSTOMERS; SPA SERVICES, NAMELY, PROVIDING TEMPORARY ACCOMMODATIONS AND MEALS TO CLIENTS OF A HEALTH OR BEAUTY SPA; AND RESERVATION SERVICES FOR HOTEL ACCOMMODATIONS FOR OTHERS (U.S. CLS. 100 AND 101).

FIRST USE 9-23-2010; IN COMMERCE 9-23-2010.

CLASS 43—HOTEL AND RESTAURANT SERVICES

CLASS 43—(Continued).

4,016,505. NP IP HOLDINGS LLC, LAS VEGAS, NV. SN 77-895,617. PUB. 4-27-2010, FILED 12-17-2009.

POINT. CLICK. CONVENE.

THE MARK CONSISTS OF STANDARD CHARACTERS WITHOUT CLAIM TO ANY PARTICULAR FONT, STYLE, SIZE, OR COLOR.

OWNER OF U.S. REG. NOS. 3,394,631 AND 3,582,178.

FOR ARENA SERVICES, NAMELY, PROVIDING FACILITIES FOR SPORTS, CONCERTS, CONVENTIONS AND EXHIBITIONS; PROVIDING CONVENTION FACILITIES (U.S. CLS. 100 AND 101).

FIRST USE 8-0-2009; IN COMMERCE 8-0-2009.

4,016,510. VERIZON TRADEMARK SERVICES LLC, ARLINGTON, VA. SN 77-896,872. PUB. 5-11-2010, FILED 12-18-2009.

VERIZON

THE MARK CONSISTS OF STANDARD CHARACTERS WITHOUT CLAIM TO ANY PARTICULAR FONT, STYLE, SIZE, OR COLOR.

OWNER OF U.S. REG. NOS. 2,879,802, 3,085,712, AND OTHERS.

FOR ARENA SERVICES, NAMELY, PROVIDING FACILITIES FOR SPORTS, CONCERTS, CONVENTIONS AND EXHIBITIONS (U.S. CLS. 100 AND 101).

FIRST USE 4-0-2000; IN COMMERCE 4-0-2000.

4,016,585. MWR HOLDINGS, LLC, BOCA RATON, FL. SN 77-935,574. PUB. 12-21-2010, FILED 2-15-2010.

THE LEARNING EXPERIENCE
CLUB HOUSE FOR KIDS

THE MARK CONSISTS OF STANDARD CHARACTERS WITHOUT CLAIM TO ANY PARTICULAR FONT, STYLE, SIZE, OR COLOR.

OWNER OF U.S. REG. NOS. 2,762,752 AND 3,214,487.

NO CLAIM IS MADE TO THE EXCLUSIVE RIGHT TO USE "FOR KIDS", APART FROM THE MARK AS SHOWN.

FOR CHILD CARE SERVICES (U.S. CLS. 100 AND 101).

FIRST USE 1-30-2010; IN COMMERCE 1-30-2010.

CLASS 43—(Continued).

4,016,733. BASS PRO INTELLECTUAL PROPERTY, L.L.C., SPRINGFIELD, MO. SN 85-005,556. PUB. 10-19-2010, FILED 4-2-2010.



NO CLAIM IS MADE TO THE EXCLUSIVE RIGHT TO USE "GRILL", APART FROM THE MARK AS SHOWN.

THE NAME(S), PORTRAIT(S), AND/OR SIGNATURE(S) SHOWN IN THE MARK DOES NOT IDENTIFY A PARTICULAR LIVING INDIVIDUAL.

THE COLOR(S) WHITE, RED, YELLOW, GREEN, GRAY, BLACK, TAN, LIGHT BROWN IS/ARE CLAIMED AS A FEATURE OF THE MARK.

THE MARK CONSISTS OF A PORTRAIT OF A MAN WITH TAN COLORED SKIN WEARING A LIGHT BROWN HAT AND CLOTHES AND BLACK GLASSES AGAINST A GREEN AND GRAY BACKGROUND ALL ENCLOSED WITHIN A YELLOW AND RED BORDER. THE WORDS "UNCLE BUCK'S" APPEAR IN WHITE FONT ACROSS THE PORTRAIT AGAINST A RED RECTANGULAR BACKGROUND SURROUNDED BY A YELLOW AND RED BORDER. ALL ABOVE THE WORDS "GRILL" IN YELLOW FONT ON A CURVED GREEN RIBBON WITH STAR OUTLINES ON EITHER SIDE.

FOR RESTAURANT SERVICES (U.S. CLS. 100 AND 101).

FIRST USE 6-0-2010; IN COMMERCE 6-0-2010.

4,016,891. VIDA Y ESTILO, CORP., MIAMI BEACH, FL. SN 85-060,866. PUB. 11-16-2010, FILED 6-11-2010.

LA CERVECERIA
DE BARRIO

NO CLAIM IS MADE TO THE EXCLUSIVE RIGHT TO USE "CERVECERIA", APART FROM THE MARK AS SHOWN.

THE MARK CONSISTS OF STYLIZED CAPITAL LETTERS THE SPANISH TERM "LA" IN SMALL CAPITAL LETTERS WITH A SHADOW AND THE WORD "CERVECERIA" IN LARGER CAPITAL LETTERS WITH SHADOW OUTLINING TO THE RIGHT OF THE WORD "LA". THE WORDS SPANISH TERM "DE BARRIO" ARE UNDERNEATH THE WORD "CERVECERIA" IN A BOLD STYLIZED FONT.

THE ENGLISH TRANSLATION OF "LA CERVECERIA DE BARRIO" IN THE MARK IS "THE BREWERY OF THE NEIGHBORHOOD".

FOR RESTAURANTS (U.S. CLS. 100 AND 101).

FIRST USE 2-3-2010; IN COMMERCE 2-3-2010.

CLASS 43—(Continued).

4,016,907. WANG WEI, GUANGDONG PROVINCE, CHINA.
SN 85-066,014. PUB. 11-16-2010, FILED 6-18-2010.

Anna in^{the} Pot

THE MARK CONSISTS OF STYLIZED WORDS "ANNA IN THE POT".

FOR CAFE; CAFETERIAS; CANTEEN SERVICES; CARRY-OUT RESTAURANTS; HOTELS; PROVIDING TEMPORARY ACCOMMODATION; RENTAL OF ROOMS AS TEMPORARY LIVING ACCOMMODATIONS; RESTAURANT; SELF-SERVICE RESTAURANTS; SNACK-BARS (U.S. CLS. 100 AND 101).

FIRST USE 1-13-2011; IN COMMERCE 1-13-2011.

CLASS 43—(Continued).

4,016,984. EFIRE GROUP, LLC, SACRAMENTO, CA. SN 85-082,474. PUB. 12-14-2010, FILED 7-12-2010.



THE MARK IS COMPRISED OF DESIGN ELEMENTS ONLY AND CONSISTS OF THE LEAVES OF AN AGAVE PLANT, WITH A PROFILE OF A FEMALE AT ITS CENTER. FOR RESTAURANT, BAR AND CATERING SERVICES (U.S. CLS. 100 AND 101).

FIRST USE 6-1-2009; IN COMMERCE 5-4-2011.

4,017,106. GLOBAL MICA, INC., ATLANTA, GA. SN 85-124,239. PUB. 2-22-2011, FILED 9-7-2010.

4,016,932. POLO FOOD & WINE GROUP, LLC, AUSTIN, TX.
SN 85-069,202. PUB. 11-16-2010, FILED 6-22-2010.

HADDINGTONS

THE MARK CONSISTS OF STANDARD CHARACTERS WITHOUT CLAIM TO ANY PARTICULAR FONT, STYLE, SIZE, OR COLOR.

FOR RESTAURANT, BAR, AND CATERING SERVICES (U.S. CLS. 100 AND 101).

FIRST USE 12-29-2010; IN COMMERCE 12-29-2010.



THE MARK CONSISTS OF A STYLIZED JESTER FACE WITH A CROWN AND A HAT, AND THE STYLIZED WORDING "BEIGNET DONE THAT" AT THE BOTTOM.

FOR RESTAURANT, CAFE, AND COFFEE HOUSE SERVICES; RESTAURANT AND CARRY-OUT FOOD SERVICES (U.S. CLS. 100 AND 101).

FIRST USE 1-15-2011; IN COMMERCE 1-15-2011.

CLASS 43—(Continued).

4,017,109. ONE CONTINENT GROUP, LLC, LAS VEGAS, NV.
SN 85-126,306. PUB. 2-8-2011, FILED 9-9-2010.

LUCYVEGAS.COM

THE MARK CONSISTS OF STANDARD CHARACTERS WITHOUT CLAIM TO ANY PARTICULAR FONT, STYLE, SIZE, OR COLOR.

FOR TRAVEL AGENCY SERVICES, NAMELY, MAKING RESERVATIONS AND BOOKINGS FOR TEMPORARY ACCOMMODATIONS; HOTELS AND LODGING SERVICES, NAMELY, PROVIDING AND RELAYING INFORMATION AND SECURING PAYMENT IN CONNECTION WITH RESERVATIONS AND BOOKINGS FOR TEMPORARY LODGING AND PROVIDING REVIEWS OF HOTELS BY MEANS OF A TELEPHONE, FACSIMILE, THE MAILS, COURIER AND OVER COMPUTER NETWORKS AND GLOBAL COMMUNICATION NETWORKS; TRAVEL AGENCY SERVICES, NAMELY, MAKING RESERVATIONS AND BOOKINGS FOR RESTAURANTS AND MEALS (U.S. CLS. 100 AND 101).

FIRST USE 9-7-2010; IN COMMERCE 1-1-2011.

4,017,147. NY'S BEST PIZZA, INC., STATEN ISLAND, NY. SN 85-144,167. PUB. 3-15-2011, FILED 10-4-2010.

**You Tried the Rest Now Try
N.Y. Best**

THE MARK CONSISTS OF STANDARD CHARACTERS WITHOUT CLAIM TO ANY PARTICULAR FONT, STYLE, SIZE, OR COLOR.

NO CLAIM IS MADE TO THE EXCLUSIVE RIGHT TO USE "N.Y.", APART FROM THE MARK AS SHOWN.

FOR PIZZA PARLORS (U.S. CLS. 100 AND 101).

FIRST USE 10-1-2010; IN COMMERCE 10-1-2010.

4,017,170. P.F. CHANG'S CHINA BISTRO, INC., SCOTTSDALE, AZ. SN 85-156,792. PUB. 3-22-2011, FILED 10-20-2010.

TRIPLE HAPPINESS

THE MARK CONSISTS OF STANDARD CHARACTERS WITHOUT CLAIM TO ANY PARTICULAR FONT, STYLE, SIZE, OR COLOR.

FOR BAR AND RESTAURANT SERVICES; RESTAURANT SERVICES, NAMELY, PROVIDING OF FOOD AND BEVERAGES FOR CONSUMPTION ON AND OFF THE PREMISES (U.S. CLS. 100 AND 101).

FIRST USE 12-27-2010; IN COMMERCE 12-27-2010.

CLASS 43—(Continued).

4,017,171. BARAMARO, LLC, CHICAGO, IL. SN 85-158,251.
PUB. 4-12-2011, FILED 10-21-2010.

MAUDE'S LIQUOR BAR

THE MARK CONSISTS OF STANDARD CHARACTERS WITHOUT CLAIM TO ANY PARTICULAR FONT, STYLE, SIZE, OR COLOR.

NO CLAIM IS MADE TO THE EXCLUSIVE RIGHT TO USE "LIQUOR BAR", APART FROM THE MARK AS SHOWN.

FOR BAR AND COCKTAIL LOUNGE SERVICES; RESTAURANT SERVICES (U.S. CLS. 100 AND 101).

FIRST USE 1-4-2011; IN COMMERCE 1-4-2011.

4,017,195. WEST RESTAURANT GROUP, L.L.C., DBA GREATFULL TACO, HOUSTON, TX. SN 85-169,977. PUB. 4-19-2011, FILED 11-5-2010.

GREATFULL TACO

THE MARK CONSISTS OF STANDARD CHARACTERS WITHOUT CLAIM TO ANY PARTICULAR FONT, STYLE, SIZE, OR COLOR.

NO CLAIM IS MADE TO THE EXCLUSIVE RIGHT TO USE "TACO", APART FROM THE MARK AS SHOWN.

FOR RESTAURANT AND BAR SERVICES (U.S. CLS. 100 AND 101).

FIRST USE 10-1-2010; IN COMMERCE 4-1-2011.

4,017,227. E & E HOLDINGS GROUP LLC, NEW YORK, NY. SN 85-189,138. PUB. 5-10-2011, FILED 12-2-2010.

E & E GRILL HOUSE

THE MARK CONSISTS OF STANDARD CHARACTERS WITHOUT CLAIM TO ANY PARTICULAR FONT, STYLE, SIZE, OR COLOR.

NO CLAIM IS MADE TO THE EXCLUSIVE RIGHT TO USE "GRILL HOUSE", APART FROM THE MARK AS SHOWN.

FOR RESTAURANT, BAR, AND COCKTAIL LOUNGE SERVICES (U.S. CLS. 100 AND 101).

FIRST USE 6-30-2011; IN COMMERCE 6-30-2011.

CLASS 43—(Continued).

4,017,245. LAM HO ENTERPRISES, INC., MAUMEE, OH. SN 85-214,446. PUB. 4-12-2011, FILED 1-10-2011.



NO CLAIM IS MADE TO THE EXCLUSIVE RIGHT TO USE "YOGURT", "FAST", "FRESH", OR "HEALTHY", APART FROM THE MARK AS SHOWN.

THE MARK CONSISTS OF THE NAME "YOGURT V" WHERE THE "V" IS COMPRISED OF A BANANA AND STRAWBERRY WITH THE PHRASE "FRESH. FAST. HEALTHY" BELOW.

FOR FROZEN YOGURT SHOP SERVICES IN THE NATURE OF A RESTAURANT (U.S. CLS. 100 AND 101). FIRST USE 2-15-2011; IN COMMERCE 2-15-2011.

CLASS 44—(Continued).

4,016,247. SURGEON'S MANAGEMENT, INC., HOUSTON, TX. SN 77-403,589. PUB. 6-9-2009, FILED 2-22-2008.

LEADING ENDOSCOPIC HAND
SURGERY

THE MARK CONSISTS OF STANDARD CHARACTERS WITHOUT CLAIM TO ANY PARTICULAR FONT, STYLE, SIZE, OR COLOR.

NO CLAIM IS MADE TO THE EXCLUSIVE RIGHT TO USE "ENDOSCOPIC HAND SURGERY", APART FROM THE MARK AS SHOWN.

FOR MEDICAL, PHYSICAL REHABILITATION AND PHYSICAL THERAPY SERVICES (U.S. CLS. 100 AND 101).

FIRST USE 11-1-2010; IN COMMERCE 12-7-2010.

CLASS 44—MEDICAL, BEAUTY AND AGRICULTURAL SERVICES

4,016,147. THE INDIAN HOTELS COMPANY LIMITED, MUMBAI - 400 001, INDIA. SN 76-648,665. PUB. 3-25-2008, FILED 10-17-2005.



THE MARK CONSISTS OF THE WORD "JIVA" AND A DEPICTION OF A FLOWER

THE ENGLISH TRANSLATION OF "JIVA" IS LIFE FORCE AND/OR IMMORTAL ESSENCE OF A LIVING BEING.

FOR HEALTH SPA SERVICES, NAMELY, COSMETIC BODY CARE AND MASSAGE SERVICES (U.S. CLS. 100 AND 101).

FIRST USE 0-0-2004; IN COMMERCE 6-10-2011.

4,016,276. THE DENVER DUMB FRIENDS LEAGUE, DENVER, CO. SN 77-560,666. PUB. 3-2-2010, FILED 9-2-2008.



NO CLAIM IS MADE TO THE EXCLUSIVE RIGHT TO USE "CHIP YOUR CAT", APART FROM THE MARK AS SHOWN.

THE MARK CONSISTS OF THE OUTLINE OF A HOUSE WITH THE DESIGN OF A CAT WEARING A PET COLLAR WITH A HEART SHAPED TAG WITHIN THE HOUSE AND THE WORDS "CHIP YOUR CAT" BELOW THE DESIGN.

FOR VETERINARY SERVICES, NAMELY, INSERTION OF SUBCUTANEOUS MICROCHIPS INTO CATS FOR PURPOSES OF IDENTIFICATION (U.S. CLS. 100 AND 101).

FIRST USE 9-27-2008; IN COMMERCE 9-27-2008.

CLASS 44—(Continued).

4,016,342. ORTHOSENSOR INC., SUNRISE, FL. SN 77-748,379. PUB. 10-5-2010, FILED 5-30-2009.

Orthosensor

THE MARK CONSISTS OF STANDARD CHARACTERS WITHOUT CLAIM TO ANY PARTICULAR FONT, STYLE, SIZE, OR COLOR.

FOR MEDICAL DIAGNOSTIC TESTING, MONITORING AND REPORTING SERVICES FOR PATIENTS HAVING IMPLANTABLE SENSORS; MEDICAL DIAGNOSTIC TESTING, MONITORING, AND REPORTING SERVICES USING MEDICAL SYSTEMS HAVING HARDWARE AND SOFTWARE THAT COLLECT, PROCESS, AND DISTRIBUTE DATA GATHERED FROM SENSORS (U.S. CLS. 100 AND 101).

FIRST USE 4-27-2009; IN COMMERCE 7-12-2011.

4,016,545. RULES-BASED MEDICINE, INC., AUSTIN, TX. SN 77-914,393. PUB. 6-1-2010, FILED 1-19-2010.

VERIPSYCH

THE MARK CONSISTS OF STANDARD CHARACTERS WITHOUT CLAIM TO ANY PARTICULAR FONT, STYLE, SIZE, OR COLOR.

FOR MEDICAL TESTING FOR DIAGNOSTIC OR TREATMENT PURPOSES, EXCLUDING STATISTICAL ANALYSIS AND MODELING OF ANTICIPATED MEDICAL EVENTS AND TREATMENTS IN THE FIELD OF HEALTH AND HEALTH INSURANCE; PERFORMING DIAGNOSIS OF DISEASES; HEALTHCARE DIAGNOSTIC SERVICES, NAMELY, PERFORMING TESTS TO ASSESS THE RISK OF DEVELOPING DISEASE, EXCLUDING STATISTICAL ANALYSIS AND MODELING OF ANTICIPATED MEDICAL EVENTS AND TREATMENTS IN THE FIELD OF HEALTH AND HEALTH INSURANCE (U.S. CLS. 100 AND 101).

FIRST USE 3-0-2010; IN COMMERCE 3-0-2010.

4,016,564. SPECIALTYCARE, INC., NASHVILLE, TN. SN 77-924,630. PUB. 5-4-2010, FILED 2-1-2010.



THE MARK CONSISTS OF A RIBBON-LIKE DESIGN INCORPORATING THE LETTERS "SC".

FOR MEDICAL SERVICES PROVIDED ON AN OUTSOURCING BASIS (U.S. CLS. 100 AND 101).

FIRST USE 2-0-2011; IN COMMERCE 2-0-2011.

CLASS 44—(Continued).

4,016,594. FLOWERS, SAKHSHAT, WILLIAM, AKA FLOWERS HEALING ARTS & CKG, MAPLEWOOD, NJ. SN 77-940,796. PUB. 7-13-2010, FILED 2-21-2010.

An Affinity for Divinity

THE MARK CONSISTS OF STANDARD CHARACTERS WITHOUT CLAIM TO ANY PARTICULAR FONT, STYLE, SIZE, OR COLOR.

FOR HEALTH CARE SERVICES, NAMELY, DISEASE MANAGEMENT PROGRAMS; HEALTH SPA SERVICES FOR HEALTH AND WELLNESS OF THE BODY AND SPIRIT (U.S. CLS. 100 AND 101).

FIRST USE 4-15-2011; IN COMMERCE 4-15-2011.

4,016,595. OLSBERG, COLLEEN A, DBA THE CHILDREN'S TOMORROW FOUNDATION, HOFFMAN ESTATES, IL. SN 77-940,819. PUB. 7-27-2010, FILED 2-21-2010.



NO CLAIM IS MADE TO THE EXCLUSIVE RIGHT TO USE "CHILDREN'S" AND "FOUNDATION", APART FROM THE MARK AS SHOWN.

THE COLOR(S) YELLOW, BLUE AND GRAY IS/ARE CLAIMED AS A FEATURE OF THE MARK.

THE MARK CONSISTS OF A YELLOW CIRCLE WITH A YELLOW STAR ON TOP WITH A SMALLER YELLOW CIRCLE INSIDE AND ONE BLUE CRESCENT ON EACH SIDE OF THE LARGER YELLOW CIRCLE. GRAY LITERAL ELEMENT READS: "THE CHILDREN'S TOMORROW FOUNDATION" ON THREE DIFFERENT LINES SEPARATED BY TWO YELLOW HORIZONTAL BARS.

FOR PROVIDING A WEB SITE FEATURING MEDICAL INFORMATION; PROVIDING MEDICAL INFORMATION (U.S. CLS. 100 AND 101).

FIRST USE 2-8-2010; IN COMMERCE 3-8-2011.

CLASS 44—(Continued).

4,016,668. THE THOUGHT EXCHANGE, LLC, MORRISTOWN, NJ. SN 77-978,607. PUB. 3-23-2010, FILED 4-2-2009.

**CHANGE YOUR THINKING,
ENHANCE YOUR LIFE!**

THE MARK CONSISTS OF STANDARD CHARACTERS WITHOUT CLAIM TO ANY PARTICULAR FONT, STYLE, SIZE, OR COLOR.

FOR MENTAL HEALTH SERVICES, PROVIDING A WEB SITE FEATURING INFORMATION IN THE FIELD OF MENTAL HEALTH AND WELLNESS (U.S. CLS. 100 AND 101).

FIRST USE 2-3-2011; IN COMMERCE 2-3-2011.

4,016,768. UHS OF DELAWARE, INC., KING OF PRUSSIA, PA. SN 85-021,403. PUB. 11-2-2010, FILED 4-23-2010.



OWNER OF U.S. REG. NOS. 2,909,837 AND 2,909,838.
NO CLAIM IS MADE TO THE EXCLUSIVE RIGHT TO USE "THE CARDIOVASCULAR CENTER AND UNIVERSITY HOSPITAL", APART FROM THE MARK AS SHOWN.

THE MARK CONSISTS OF A STYLIZED HEART DESIGN SURROUNDING A DEPICTION OF THE U.S. CAPITOL DOME. TO THE RIGHT OF THE DESIGN ARE THE WORDS "THE CARDIOVASCULAR CENTER" ABOVE A SOLID LINE WITH THE WORDS "THE GEORGE WASHINGTON UNIVERSITY HOSPITAL" BELOW THE LINE.

FOR MEDICAL AND HEALTHCARE SERVICES (U.S. CLS. 100 AND 101).

FIRST USE 7-20-2010; IN COMMERCE 7-20-2010.

4,016,803. UHS OF DELAWARE, INC., KING OF PRUSSIA, PA. SN 85-036,848. PUB. 10-26-2010, FILED 5-12-2010.



NO CLAIM IS MADE TO THE EXCLUSIVE RIGHT TO USE "REHABILITATION AND ORTHOPEDIC INSTITUTE A PROGRAM OF PALMDALE REGIONAL MEDICAL CENTER", APART FROM THE MARK AS SHOWN.

THE MARK CONSISTS OF THE WORDS "REHABILITATION AND ORTHOPEDIC INSTITUTE A PROGRAM OF PALMDALE REGIONAL MEDICAL CENTER" TO THE RIGHT OF A CIRCULAR DESIGN WITH A SILHOUETTE OF PALM LEAVES THEREIN.

FOR MEDICAL AND HEALTHCARE SERVICES (U.S. CLS. 100 AND 101).

FIRST USE 6-21-2011; IN COMMERCE 6-21-2011.

CLASS 44—(Continued).

4,016,921. RIZOBACTER ARGENTINA S.A., PERGAMINO, ARGENTINA. SN 85-067,701. PUB. 11-9-2010, FILED 6-21-2010.



NO CLAIM IS MADE TO THE EXCLUSIVE RIGHT TO USE "ARGENTINA S.A.", APART FROM THE MARK AS SHOWN.

THE COLOR(S) WHITE, GREY, BLUE, PALE BLUE, THEIR SHADES AND THREE-DIMENSIONAL EFFECT IS/ARE CLAIMED AS A FEATURE OF THE MARK.

THE MARK CONSISTS OF THE WORD "RIZOBACTER" IN BLUE COLOR, OVER THE WORDS "ARGENTINA S.A." IN PALE BLUE COLOR; BOTH AT THE RIGHT SIDE OF THE IMAGE OF GREY RING, CONTAINING A PALE BLUE RING, CONTAINING A BLUE RING, CONTAINING A WHITE RING, CONTAINING THE IMAGE OF A GREY SHADED CHEMISTRY BOTTLE OVER A BLUE BACKGROUND. THE RINGS APPEAR TO BE SLIGHTLY TURNED TO THE SIDE, WITH SHADES THAT CREATE A THREE-DIMENSIONAL EFFECT.

THE WORDING "RIZOBACTER" HAS NO MEANING IN A FOREIGN LANGUAGE.

FOR AGRICULTURAL ADVICE, NAMELY, PROVIDING RECOMMENDATIONS FOR PLANT AND SOIL NUTRITION SUPPLEMENTS (U.S. CLS. 100 AND 101).

FIRST USE 2-5-1988; IN COMMERCE 1-15-2011.

4,017,084. URBAN DECAY COSMETICS LLC, NEWPORT BEACH, CA. SN 85-113,970. PUB. 12-7-2010, FILED 8-23-2010.

UD

THE MARK CONSISTS OF THE STYLIZED LETTERS "UD".

FOR BEAUTY CONSULTATION SERVICES IN THE SELECTION AND USE OF COSMETICS, BEAUTY AIDS, PERSONAL CARE PRODUCTS, BODY AND BEAUTY PRODUCTS; BEAUTY CONSULTATION SERVICES; PROVIDING INFORMATION ABOUT BEAUTY; MAKE-UP APPLICATION SERVICES; BEAUTY ANALYSIS TO DETERMINE COSMETICS THAT ARE BEST SUITED FOR PARTICULAR INDIVIDUALS; COSMETIC SKIN CARE SERVICES; COSMETIC FACE CARE SERVICES (U.S. CLS. 100 AND 101).

FIRST USE 6-30-2010; IN COMMERCE 6-30-2010.

CLASS 44—(Continued).

4,017,085. URBAN DECAY COSMETICS LLC, NEWPORT BEACH, CA. SN 85-113,978. PUB. 11-23-2010, FILED 8-23-2010.

UD

THE MARK CONSISTS OF STANDARD CHARACTERS WITHOUT CLAIM TO ANY PARTICULAR FONT, STYLE, SIZE, OR COLOR.

FOR BEAUTY CONSULTATION SERVICES IN THE SELECTION AND USE OF COSMETICS, BEAUTY AIDS, PERSONAL CARE PRODUCTS, BODY AND BEAUTY PRODUCTS; BEAUTY CONSULTATION SERVICES; PROVIDING INFORMATION ABOUT BEAUTY; MAKE-UP APPLICATION SERVICES; BEAUTY ANALYSIS TO DETERMINE COSMETICS THAT ARE BEST SUITED FOR PARTICULAR INDIVIDUALS; COSMETIC SKIN CARE SERVICES; COSMETIC FACE CARE SERVICES (U.S. CLS. 100 AND 101).

FIRST USE 6-30-2010; IN COMMERCE 6-30-2010.

4,017,125. BOSTON PAINCARE CENTER, INC., WALTHAM, MA. SN 85-132,249. PUB. 3-8-2011, FILED 9-17-2010.

Boston PainCare. Live Again.

THE MARK CONSISTS OF STANDARD CHARACTERS WITHOUT CLAIM TO ANY PARTICULAR FONT, STYLE, SIZE, OR COLOR.

NO CLAIM IS MADE TO THE EXCLUSIVE RIGHT TO USE "BOSTON PAIN CARE", APART FROM THE MARK AS SHOWN.

FOR MEDICAL CLINIC PROVIDING ACUTE AND CHRONIC PAIN ASSESSMENT, MANAGEMENT, AND TREATMENT SERVICES BY DOCTORS AND OTHER SPECIALIZED MEDICAL PERSONNEL AND INTERDISCIPLINARY PRACTITIONERS, INCLUDING PAIN MEDICINE, ANESTHESIOLOGY, PHYSIATRY, PHYSICAL MEDICINE AND REHABILITATION, FUNCTIONAL REHABILITATION, PALLIATIVE MEDICINE, SLEEP MEDICINE, PSYCHOLOGY AND BEHAVIORAL MODIFICATION, ACUPUNCTURE THERAPY, AND REFERRAL AND CONSULTATIVE SERVICES IN THE FIELD OF PAIN CARE (U.S. CLS. 100 AND 101).

FIRST USE 3-1-2011; IN COMMERCE 3-1-2011.

CLASS 44—(Continued).

4,017,153. MERIDIAN BEHAVIORAL HEALTH, LLC, NEW BRIGHTON, MN. SN 85-149,647. PUB. 3-15-2011, FILED 10-11-2010.

With Change Comes Clarity

THE MARK CONSISTS OF STANDARD CHARACTERS WITHOUT CLAIM TO ANY PARTICULAR FONT, STYLE, SIZE, OR COLOR.

FOR ALCOHOL AND DRUG ADDICTION TREATMENT SERVICES (U.S. CLS. 100 AND 101).

FIRST USE 1-31-2011; IN COMMERCE 1-31-2011.

4,017,158. CARING HANDS FOR SENIORS, BRISTOW, VA. SN 85-151,109. PUB. 4-5-2011, FILED 10-12-2010.



NO CLAIM IS MADE TO THE EXCLUSIVE RIGHT TO USE "SENIORS/SPECIAL NEEDS", APART FROM THE MARK AS SHOWN.

THE COLOR(S) RED, BLUE, WHITE AND BLACK IS/ARE CLAIMED AS A FEATURE OF THE MARK.

THE MARK CONSISTS OF THE WORDS "COMPASSIONATE HEARTS FOR SENIORS/SPECIAL NEEDS" AND THE DESIGN OF AN ANGEL HOLDING A HEART. THE LETTER "C" IN "COMPASSIONATE" IS THE COLOR RED, THE REMAINING LETTERS ARE BLACK; THE LETTER "H" IN THE WORD "HEARTS" APPEARS IN THE COLOR RED, THE REMAINING LETTERS ARE BLACK; THE LETTER "F" IN THE WORD "FOR" APPEARS IN THE COLOR RED, THE REMAINING LETTERS ARE BLACK; THE LETTER "S" IN THE WORD "SENIORS" APPEARS IN THE COLOR RED, THE REMAINING LETTERS ARE BLACK; THE WORDS "SPECIAL NEEDS" APPEAR IN THE COLOR BLACK; THERE IS AN ANGEL OUTLINED IN COLOR BLUE; THE BODY OF THE ANGEL IS IN THE COLOR WHITE; THE ANGEL IS HOLDING A HEART; THE HEART IS OUTLINED IN THE COLOR BLUE; THE COLOR RED APPEARS INSIDE THE HEART.

FOR HOME HEALTH CARE SERVICES; HOME HEALTH CARE SERVICES, NAMELY, PHYSICAL THERAPY AND SKILLED NURSING; HOME NURSING AID SERVICES (U.S. CLS. 100 AND 101).

FIRST USE 1-2-2011; IN COMMERCE 2-23-2011.

CLASS 44—(Continued).

4,017,235. TRUGREEN LIMITED PARTNERSHIP, MEMPHIS, TN. SN 85-196,283. PUB. 4-26-2011, FILED 12-13-2010.

TruStories

THE MARK CONSISTS OF STANDARD CHARACTERS WITHOUT CLAIM TO ANY PARTICULAR FONT, STYLE, SIZE, OR COLOR.

OWNER OF U.S. REG. NOS. 2,543,094, 3,616,893, AND OTHERS.

FOR LAWN, TREE, AND SHRUB CARE (U.S. CLS. 100 AND 101).

FIRST USE 1-14-2011; IN COMMERCE 1-14-2011.

CLASS 45—PERSONAL AND LEGAL SERVICES

4,016,228. ID ANALYTICS, INC., SAN DIEGO, CA. SN 77-347,244. PUB. 4-15-2008, FILED 12-7-2007.

'id:a

FOR CONSULTING SERVICES IN THE FIELD OF IDENTITY FRAUD; IDENTITY THEFT PROTECTION SERVICES THAT PROVIDE FRAUD PREVENTION AND PROTECTION BY MONITORING FINANCIAL DATA BASED UPON IDENTITY INFORMATION; ASSISTING COMPANIES, ORGANIZATIONS, ACADEMIC INSTITUTIONS, AND GOVERNMENT AGENCIES TO RECOGNIZE, ASSESS, SCREEN, MONITOR, VALIDATE AND PREVENT THE MISUSE OR THEFT OF PERSONAL IDENTITY INFORMATION AND FINANCIAL INFORMATION (U.S. CLS. 100 AND 101).

FIRST USE 12-0-2010; IN COMMERCE 12-0-2010.

4,016,292. JCW ENTERPRISES, INC., NEW YORK, NY. SN 77-637,858. PUB. 4-21-2009, FILED 12-22-2008.

SHANIKA

THE MARK CONSISTS OF STANDARD CHARACTERS WITHOUT CLAIM TO ANY PARTICULAR FONT, STYLE, SIZE, OR COLOR.

FOR CARTOON CHARACTER LICENSING (U.S. CLS. 100 AND 101).

FIRST USE 3-1-2011; IN COMMERCE 3-1-2011.

CLASS 45—(Continued).

4,016,398. SCHWEGMAN, LUNDBERG & WOESSNER, P.A., MINNEAPOLIS, MN. SN 77-824,831. PUB. 6-15-2010, FILED 9-11-2009.



OWNER OF U.S. REG. NO. 2,917,245.

NO CLAIM IS MADE TO THE EXCLUSIVE RIGHT TO USE "PATENT PROTECTION FOR GREEN TECHNOLOGY" AND "PROTECTION FOR GREEN TECH" AND "A PROFESSIONAL ASSOCIATION", APART FROM THE MARK AS SHOWN.

THE COLOR(S) WHITE, BLUE AND GREEN IS/ARE CLAIMED AS A FEATURE OF THE MARK.

THE MARK CONSISTS OF A GREEN SQUARE WITH DOUBLE OUTLINES IN WHITE AND BLUE. WITHIN THE SQUARE IS A GLOBE WITH BLUE WATER AND GREEN CONTINENTS WITH THREE WHITE ARROWS OUTLINED IN BLUE AROUND THE OUTSIDE OF THE GLOBE WHICH FORM A TRIANGLE. ACROSS THE GLOBE IS A WHITE BANNER OUTLINED IN BLUE, AND WITHIN THE BANNER IS A BLUE SQUARE CONTAINING "SLW" IN WHITE LETTERS, AND THE WORDS "SCHWEGMAN [SQUARE SYMBOL] LUNDBERG [SQUARE SYMBOL] WOESSNER" PATENT PROTECTION FOR GREEN TECHNOLOGY IN BLUE. UNDERNEATH THE GLOBE ARE THE WORDS "PROTECTION FOR" IN WHITE, "GREEN TECH" IN BLUE AND OUTLINED IN WHITE. UNDERNEATH "GREEN TECH" IS A BLUE HORIZONTAL LINE WITH "SLWIP.COM" IN WHITE IN THE MIDDLE OF THE LINE. UNDERNEATH THE LINE ARE THE WORDS "A PROFESSIONAL ASSOCIATION" IN WHITE.

FOR PROVIDING INTELLECTUAL PROPERTY LEGAL SERVICES AND COUNSELING TO OTHERS (U.S. CLS. 100 AND 101).

FIRST USE 6-8-2011; IN COMMERCE 6-8-2011.

4,016,452. TRANSPARENT VISIBILITY HOLDINGS, LLC, BENTONVILLE, AR. SN 77-879,144. PUB. 11-2-2010, FILED 11-23-2009.

ICN Answer

THE MARK CONSISTS OF STANDARD CHARACTERS WITHOUT CLAIM TO ANY PARTICULAR FONT, STYLE, SIZE, OR COLOR.

FOR PROVIDING INFORMATION IN THE FIELD OF SELF-IMPROVEMENT, NAMELY, ON TOPICS OF PLANNING, EFFECTIVENESS, EFFICIENCY, AND LEADERSHIP (U.S. CLS. 100 AND 101).

FIRST USE 10-0-2008; IN COMMERCE 10-0-2008.

CLASS 45—(Continued).

4,016,457. ROCKET21 ENTERPRISES, LLC, FAIRFIELD, CT. SN 77-882,034. PUB. 5-4-2010, FILED 11-30-2009.

ROCKET21

THE MARK CONSISTS OF STANDARD CHARACTERS WITHOUT CLAIM TO ANY PARTICULAR FONT, STYLE, SIZE, OR COLOR.

FOR PROVIDING A SOCIAL NETWORKING WEBSITE FEATURING INFORMATION IN THE FIELD OF PERSONAL AND PROFESSIONAL DEVELOPMENT, INDUSTRIES AND CAREERS, AND ASSISTANCE WITH HOMEWORK ASSIGNMENTS, ALL FOR STUDENTS (U.S. CLS. 100 AND 101).
FIRST USE 2-23-2011; IN COMMERCE 2-23-2011.

4,016,634. LEGAL AID SOCIETY-EMPLOYMENT LAW CENTER, SAN FRANCISCO, CA. SN 77-954,166. PUB. 2-15-2011, FILED 3-9-2010.

PUTTING JUSTICE TO WORK

THE MARK CONSISTS OF STANDARD CHARACTERS WITHOUT CLAIM TO ANY PARTICULAR FONT, STYLE, SIZE, OR COLOR.

FOR LEGAL SERVICES, NAMELY, PROVIDING INFORMATION, COUNSELING, ADVICE, AND LITIGATION TO LOW-INCOME WORKERS IN ALL AREAS OF EMPLOYMENT AND LABOR LAW (U.S. CLS. 100 AND 101).
FIRST USE 5-0-2010; IN COMMERCE 5-0-2010.

4,016,644. GERSTEN SAVAGE LLP, NEW YORK, NY. SN 77-957,985. PUB. 8-3-2010, FILED 3-12-2010.

Give Us An Opportunity to Listen

THE MARK CONSISTS OF STANDARD CHARACTERS WITHOUT CLAIM TO ANY PARTICULAR FONT, STYLE, SIZE, OR COLOR.

FOR LEGAL SERVICES (U.S. CLS. 100 AND 101).
FIRST USE 9-28-2010; IN COMMERCE 9-28-2010.

CLASS 45—(Continued).

4,016,686. LINKEDIN CORPORATION, MOUNTAIN VIEW, CA. SN 77-982,141. PUB. 5-18-2010, FILED 7-16-2009.



OWNER OF U.S. REG. NOS. 3,074,241, 3,074,242, AND 3,303,349.

THE MARK CONSISTS OF THE WORD "IN" SHOWN INSIDE A SQUARE WITH A SHADED BACKGROUND.

FOR SOCIAL INTRODUCTION AND SOCIAL NETWORKING SERVICES; LICENSING OF COMPUTER SOFTWARE AND INTELLECTUAL PROPERTY (U.S. CLS. 100 AND 101).
FIRST USE 5-0-2003; IN COMMERCE 5-0-2003.

4,016,688. LINKEDIN CORPORATION, MOUNTAIN VIEW, CA. SN 77-982,145. PUB. 5-11-2010, FILED 7-16-2009.



OWNER OF U.S. REG. NOS. 3,074,241, 3,074,242, AND 3,303,349.

THE COLOR(S) BLUE AND WHITE IS/ARE CLAIMED AS A FEATURE OF THE MARK.

THE MARK CONSISTS OF THE WORD "IN" SHOWN IN WHITE LETTERS INSIDE A BLUE SQUARE.

FOR SOCIAL INTRODUCTION AND SOCIAL NETWORKING SERVICES; LICENSING OF COMPUTER SOFTWARE AND INTELLECTUAL PROPERTY (U.S. CLS. 100 AND 101).
FIRST USE 5-0-2003; IN COMMERCE 5-0-2003.

CLASS 45—(Continued).

4,016,908. UHS OF DELAWARE, INC., KING OF PRUSSIA, PA. SN 85-066,129. PUB. 10-19-2010, FILED 6-18-2010.

BEARY BUDDIES

THE MARK CONSISTS OF STANDARD CHARACTERS WITHOUT CLAIM TO ANY PARTICULAR FONT, STYLE, SIZE, OR COLOR.

FOR ORGANIZING AND CONDUCTING SUPPORT GROUPS IN THE FIELD OF BARIATRIC MEDICAL AND HEALTH CARE ISSUES (U.S. CLS. 100 AND 101).
FIRST USE 6-0-2010; IN COMMERCE 6-0-2010.

4,016,928. BABCOCK PARTNERS, LLC, BATON ROUGE, LA. SN 85-068,712. PUB. 11-23-2010, FILED 6-22-2010.

A NEW BREED OF LAW FIRM

THE MARK CONSISTS OF STANDARD CHARACTERS WITHOUT CLAIM TO ANY PARTICULAR FONT, STYLE, SIZE, OR COLOR.

FOR LEGAL SERVICES (U.S. CLS. 100 AND 101).
FIRST USE 1-1-2011; IN COMMERCE 1-1-2011.

4,016,969. THE BAUE FUNERAL HOME CO., ST. CHARLES, MO. SN 85-078,583. PUB. 11-16-2010, FILED 7-6-2010.

Baue
cremations • burials • tributes
Pet Services

OWNER OF U.S. REG. NOS. 3,520,061, 3,520,062, AND 3,709,572.

NO CLAIM IS MADE TO THE EXCLUSIVE RIGHT TO USE "CREMATIONS BURIALS TRIBUTES" OR "PET SERVICES", APART FROM THE MARK AS SHOWN.

THE MARK CONSISTS OF THE WORDS "BAUE" AND "PET SERVICES" SEPARATED BY THE WORDS "CREMATIONS BURIALS TRIBUTES", WHICH APPEAR IN A DARK RECTANGLE.

SEC. 2(F) AS TO "BAUE".

FOR FUNERAL SERVICES FOR ANIMALS; FUNERAL ARRANGEMENT SERVICES FOR ANIMALS; FUNERAL SERVICES FOR ANIMALS ACCOMPANYING CREMATION (U.S. CLS. 100 AND 101).

FIRST USE 12-0-2010; IN COMMERCE 12-0-2010.

CLASS 45—(Continued).

4,016,970. THE BAUE FUNERAL HOME CO., ST. CHARLES, MO. SN 85-078,589. PUB. 11-16-2010, FILED 7-6-2010.



OWNER OF U.S. REG. NO. 3,520,062.

THE MARK CONSISTS OF A STYLIZED LETTER "B" WITHIN A BOX. A CAT IS WALKING ON TOP OF THE BOX AND A HOWLING DOG IS TO THE LEFT OF THE BOX.

FOR FUNERAL SERVICES FOR ANIMALS; FUNERAL ARRANGEMENT SERVICES FOR ANIMALS; FUNERAL SERVICES FOR ANIMALS ACCOMPANYING CREMATION (U.S. CLS. 100 AND 101).

FIRST USE 12-0-2010; IN COMMERCE 12-0-2010.

4,017,208. MICHAEL HAYNES PLC, KESWICK, VA. SN 85-176,601. PUB. 4-5-2011, FILED 11-15-2010.

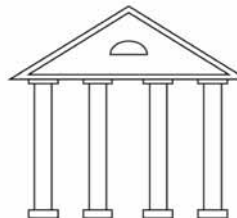

THE MARK CONSISTS OF A DESIGN ELEMENT FEATURING 4 SUBSTANTIALLY EQUALLY-DISTRIBUTED COLUMNS SUPPORTING A TRIANGULAR GABLE, THE GABLE HAVING A SUBSTANTIALLY CENTERED SEMI-ELLIPTICAL WINDOW.

FOR LEGAL SERVICES (U.S. CLS. 100 AND 101).
FIRST USE 5-31-2011; IN COMMERCE 5-31-2011.

CLASS 45—(Continued).

4,017,257. SEA CLIFF VENTURES INC., SWIEQI, MALTA.
SN 85-975,405. PUB. 4-5-2011, FILED 6-3-2010.

IHOOKUP.COM

THE MARK CONSISTS OF STANDARD CHARACTERS
WITHOUT CLAIM TO ANY PARTICULAR FONT, STYLE,
SIZE, OR COLOR.

FOR ONLINE ADULT DATING, SOCIAL INTRODUC-
TION, SOCIAL NETWORK AND DATE MATCHING
SERVICES PROVIDED OVER THE INTERNET (U.S.
CLS. 100 AND 101).

FIRST USE 1-20-2011; IN COMMERCE 1-20-2011.

* * * * *

PRIOR UNITED STATES CLASSIFICATION

APPLICATION IN ONE CLASS

COLLECTIVE MEMBERSHIP MARKS

CLASS 200—COLLECTIVE MEMBERSHIP

4,016,767. THE COLORADO BAR ASSOCIATION, DENVER, CO. SN 85-021,119. PUB. 10-26-2010, FILED 4-22-2010.



NO CLAIM IS MADE TO THE EXCLUSIVE RIGHT TO USE "EST. IN 1897"; "MEMBER" AND "BAR ASSOCIATION", APART FROM THE MARK AS SHOWN.

THE MARK CONSISTS OF THE ACRONYM "CBA" IS SUPERIMPOSED OVER A BACKGROUND IMAGE OF A RANGE OF MOUNTAIN PEAKS, ACCENTED BY PATCHES OF SNOW, ABOVE A HORIZONTAL LINE; "EST. IN 1897" IS CENTERED IN A BREAK IN THE HORIZONTAL LINE; "COLORADO BAR ASSOCIATION" IS CENTERED BELOW THE HORIZONTAL LINE; "MEMBER" IS CENTERED ACROSS THE BOTTOM OF THE LOGO.

SEC. 2(F) AS TO "COLORADO BAR ASSOCIATION". FOR INDICATING MEMBERSHIP IN AN ASSOCIATION OF LAWYERS AND LEGAL PROFESSIONALS (U.S. CL. 200).

FIRST USE 4-22-2010; IN COMMERCE 5-22-2010.

CERTIFICATION MARKS

CLASS B—SERVICES

4,016,307. ANY INC., OKLAHOMA CITY, OK. SN 77-676,657. PUB. 10-26-2010, FILED 2-24-2009.



NO CLAIM IS MADE TO THE EXCLUSIVE RIGHT TO USE "CERTIFIED HCG WEIGHT LOSS", APART FROM THE MARK AS SHOWN.

THE MARK CONSISTS OF THE STYLIZED WORDING "TRIMYOU", WITH A CIRCLE DESIGN OVER THE LETTER "Y" FORMING A STYLIZED HUMAN FIGURE, WITH THE WORDING "CERTIFIED HCG WEIGHT LOSS" LOCATED BELOW THE FOREGOING, ALL LOCATED WITHIN AN OVAL.

THE CERTIFICATION MARK, AS USED OR INTENDED TO BE USED BY PERSONS AUTHORIZED BY THE CERTIFIER, CERTIFIES THAT THE SERVICES PROVIDED ADHERE TO THE ORIGINAL DR. SIMEONS HUMAN CHORIONIC GONADOTROPIN (HCG) DIET PROTOCOL; THAT THE HCG DIET OFFERED FOLLOWS THE STRICT GUIDELINES OF DR. SIMEONS' ORIGINAL PROTOCOL AS DOCUMENTED IN "POUNDS AND INCHES: A NEW APPROACH TO OBESITY"; AND THAT THE CLINIC ADMINISTERING THE SERVICES MAINTAINS THE HIGHEST ETHICAL STANDARDS.

FOR WEIGHT LOSS PROGRAMS, WEIGHT LOSS SERVICES AND WEIGHT LOSS CLINICS (U.S. CL. B).

FIRST USE 5-0-2009; IN COMMERCE 5-0-2009.

* * * * *

SUPPLEMENTAL REGISTER

These registrations are not subject to opposition.

SECTION 1.— INTERNATIONAL CLASSIFICATION

The short titles associated below with the international class numbers are terms designed merely for quick identification and are not an official part of the international classification. The full names of international classes are given in section 6.1 of the trademark rules of practice.

The designation "U.S. Cl." appearing in this section refers to the U.S. class in effect prior to Sep. 1, 1973 rather than the international class which applies to applications filed on or after that date. For adoption of international classification see notice in the OFFICIAL GAZETTE of Jun. 26, 1973 (911 O.G. TM 210).

Application in more than one class

4,017,276. INTERNATIONAL BUSINESS MACHINES CORP., ARMONK, NY. SN 77-742,750. FILED P.R. 5-22-2009; AM. S.R. 12-6-2010.

CLASS 42—SCIENTIFIC AND COMPUTER SERVICES

FOR COMPUTER SYSTEMS INTEGRATION SERVICES; COMPUTER CONSULTATION SERVICES; CONSULTING SERVICES IN THE FIELD OF DESIGN, SELECTION, IMPLEMENTATION AND USE OF COMPUTER HARDWARE AND SOFTWARE SYSTEMS FOR OTHERS; TECHNICAL SUPPORT SERVICES, NAMELY, TROUBLESHOOTING OF COMPUTERS, SERVERS AND COMPUTER SOFTWARE PROBLEMS; COMPUTER SYSTEMS DESIGN SERVICES FOR OTHERS; COMPUTER SYSTEMS ANALYSIS; INTERCONNECTION OF COMPUTER HARDWARE AND SOFTWARE, NAMELY, INTEGRATION OF COMPUTER SYSTEMS AND NETWORKS; COMPUTER SOFTWARE AND HARDWARE TESTING SERVICES, NAMELY, TESTING OF COMPUTER SOFTWARE, COMPUTERS AND SERVERS; INSTALLATION, UPDATING AND MAINTENANCE OF COMPUTER SOFTWARE; COMPUTER PROGRAMMING FOR OTHERS (U.S. CLS. 100 AND 101).
FIRST USE 5-31-2001; IN COMMERCE 5-31-2001.

LIVEAUDIT

4,017,283. TVI CORPORATION, GLENN DALE, MD. SN 77-838,557. FILED P.R. 9-30-2009; AM. S.R. 7-7-2011.

THE MARK CONSISTS OF STANDARD CHARACTERS WITHOUT CLAIM TO ANY PARTICULAR FONT, STYLE, SIZE, OR COLOR.

CLASS 9—ELECTRICAL AND SCIENTIFIC APPARATUS

FOR COMPUTER SOFTWARE TO MONITOR, DOCUMENT, EVALUATE, ASSESS AND COMPARE CHANGES TO DATABASES IN THE FIELD OF DATABASE MANAGEMENT, DATABASE SOFTWARE AND DATA, NAMELY, COMPUTER SOFTWARE FOR DATABASE MANAGEMENT (U.S. CLS. 21, 23, 26, 36 AND 38).
FIRST USE 5-31-2001; IN COMMERCE 5-31-2001.

CLASS 16—PAPER GOODS AND PRINTED MATTER

FOR PRINTED MATERIALS, NAMELY, BOOKS, BROCHURES, INFORMATIONAL SHEETS, INSTRUCTIONAL MANUALS, WRITTEN PRESENTATIONS IN THE FIELD OF COMPUTER SOFTWARE FOR DATABASE MANAGEMENT, AND PRINTED INSTRUCTIONAL AND TEACHING MATERIALS IN THE FIELD OF COMPUTER SOFTWARE FOR DATABASE MANAGEMENT (U.S. CLS. 2, 5, 22, 23, 29, 37, 38 AND 50).
FIRST USE 5-31-2001; IN COMMERCE 5-31-2001.

IMMEDIATE RESPONSE TECHNOLOGIES

THE MARK CONSISTS OF STANDARD CHARACTERS WITHOUT CLAIM TO ANY PARTICULAR FONT, STYLE, SIZE, OR COLOR.

CLASS 9—ELECTRICAL AND SCIENTIFIC APPARATUS

FOR RESPIRATOR PRODUCTS FOR USE BY FIRST RESPONDER, MILITARY, HEALTHCARE, INDUSTRIAL AND OTHER SAFETY-RELATED PERSONNEL, NAMELY, POWERED AIR PURIFYING RESPIRATORS AND FILTERS, INFRARED AND THERMAL MARKING AND SIGNALING DEVICES, NAMELY, TARGETS, BEACONS, PADS, PANELS, BORESIGHT PANELS, PLATFORMS, AND SOLDIERS COMBAT HELMET INFRARED DEVICES FOR USE BY MILITARY AND LAW ENFORCEMENT IN BOTH TRAINING AND OPERATIONAL SETTINGS (U.S. CLS. 21, 23, 26, 36 AND 38).
FIRST USE 12-9-2009; IN COMMERCE 12-9-2009.

CLASS 11—ENVIRONMENTAL CONTROL APPARATUS

FOR RAPIDLY DEPLOYABLE RIGID AND NON-RIGID SHELTER SYSTEMS FOR THE FIRST RESPONDER, FIRST RECEIVER, GOVERNMENT, MILITARY AND COMMERCIAL MARKETS COMPRISED OF HAND SPRAYERS, SHOWER NOZZLES, WATER HOSES, WATER PUMPS, AND FLOOR RISERS, RAPIDLY DEPLOYABLE RIGID AND NON-RIGID SHELTER SYSTEMS FOR THE FIRST RESPONDER, FIRST RECEIVER, GOVERNMENT, MILITARY AND COMMERCIAL MARKETS COMPRISED OF HAND SPRAYERS, SHOWER NOZZLES, WATER HOSES, WATER PUMPS, AND WATER HEATERS, RAPIDLY DEPLOYABLE RIGID AND NON-RIGID SHELTER SYSTEMS FOR THE FIRST RESPONDER, FIRST RECEIVER, GOVERNMENT, MILITARY AND COMMERCIAL MARKETS COMPRISED OF HAND SPRAYERS, SHOWER NOZZLES, WATER HOSES, WATER PUMPS, WATER HEATERS, LIGHT FIXTURES, LITTER CONVEYORS, AND FLOOR RISERS, RAPIDLY DEPLOYABLE RIGID AND NON-RIGID SHELTER SYSTEMS FOR THE FIRST RESPONDER, FIRST RECEIVER, GOVERNMENT, MILITARY AND COMMERCIAL MARKETS COMPRISED OF HAND SPRAYERS, SHOWER NOZZLES, WATER HOSES, WATER PUMPS, WATER HEATERS, AIR HEATERS, HAND TRUCKS, TRAILERS, ELECTRICITY GENERATORS, FILTERS, LITTER CONVEYORS, LIGHT FIXTURES AND FLOOR RISERS, RAPIDLY DEPLOYABLE RIGID AND NON-RIGID SHELTER SYSTEMS FOR THE FIRST RESPONDER, FIRST RECEIVER, GOVERNMENT, MILITARY AND COMMERCIAL MARKETS COMPRISED OF SHOWERS, LATRINES, LAUNDRY FACILITIES, HVAC UNITS, LIGHT FIXTURES, FLOORING, GENERATORS, AND ELECTRICAL DISTRIBUTION COMPONENTS (U.S. CLS. 13, 21, 23, 31 AND 34).
FIRST USE 12-9-2009; IN COMMERCE 12-9-2009.

4,017,294. RSA 1 LIMITED PARTNERSHIP, EMERSON, IA. AND IOWA RSA 2 LIMITED PARTNERSHIP, EMERSON, IA. SN 77-968,548. FILED P.R. 3-25-2010; AM. S.R. 7-6-2011.

CHAT MOBILITY

THE MARK CONSISTS OF STANDARD CHARACTERS WITHOUT CLAIM TO ANY PARTICULAR FONT, STYLE, SIZE, OR COLOR.

NO CLAIM IS MADE TO THE EXCLUSIVE RIGHT TO USE "CHAT", APART FROM THE MARK AS SHOWN.

CLASS 9—ELECTRICAL AND SCIENTIFIC APPARATUS

FOR CELLULAR TELEPHONE APPARATUSES; CELLULAR TELEPHONES; DIGITAL TELEPHONES; MOBILE TELEPHONES; PORTABLE TELEPHONES; TELEPHONE APPARATUS; TELEPHONES; WIRELESS TELEPHONES (U.S. CLS. 21, 23, 26, 36 AND 38).
FIRST USE 3-24-2010; IN COMMERCE 3-24-2010.

CLASS 38—COMMUNICATION

FOR CELLULAR TELEPHONE COMMUNICATION; CELLULAR TELEPHONE SERVICES; COMMUNICATION BY MOBILE TELEPHONE; COMMUNICATIONS BY TELEPHONE; FIXED AND MOBILE TELEPHONE SERVICES; LOCAL AND LONG DISTANCE TELEPHONE SERVICES; MOBILE TELEPHONE COMMUNICATION; MOBILE TELEPHONE SERVICES; PROVIDING TELEPHONE CONFERENCING SERVICES; TELECOMMUNICATION SERVICES IN THE NATURE OF PROVIDING TELEPHONE FEATURES, NAMELY, CALL WAITING, CALL IDENTIFICATION, CALL FORWARDING, AND MESSAGE WAITING; TELEPHONE COMMUNICATIONS; TELEPHONE VOICE MESSAGING SERVICES; WIRELESS TELEPHONE TELECOMMUNICATIONS SERVICES, NAMELY, WIRELESS MOBILE TELEPHONE CALLING PLANS (U.S. CLS. 100, 101 AND 104).

FIRST USE 3-24-2010; IN COMMERCE 3-24-2010.

4,017,303. COLLEGIATE TARTAN APPAREL, LLC, GREENSBORO, NC. SN 85-049,733. FILED P.R. 5-27-2010; AM. S.R. 3-8-2011.

COLLEGIATE TARTAN

THE MARK CONSISTS OF STANDARD CHARACTERS WITHOUT CLAIM TO ANY PARTICULAR FONT, STYLE, SIZE, OR COLOR.

NO CLAIM IS MADE TO THE EXCLUSIVE RIGHT TO USE "TARTAN", APART FROM THE MARK AS SHOWN.

CLASS 24—FABRICS

FOR FABRICS, NAMELY, BEDDING BLANKETS, STADIUM BLANKETS, AND THROWS (U.S. CLS. 42 AND 50).

FIRST USE 1-27-2010; IN COMMERCE 6-7-2010.

CLASS 25—CLOTHING

FOR CLOTHING, NAMELY, HEADWEAR, HATS, CAPS, TAMS, BARNTON CAPS, BERETS, NECKWEAR, TIES, AND BOWTIES (U.S. CLS. 22 AND 39).

FIRST USE 1-27-2010; IN COMMERCE 6-7-2010.

4,017,305. WORLD'S BEST, LLC, EAST STROUDSBURG, PA. SN 85-091,250. FILED P.R. 7-23-2010; AM. S.R. 7-8-2011.

WORLD'S BEST

THE MARK CONSISTS OF STANDARD CHARACTERS WITHOUT CLAIM TO ANY PARTICULAR FONT, STYLE, SIZE, OR COLOR.

CLASS 31—NATURAL AGRICULTURAL PRODUCTS

4,017,313. BNP MEDIA II, LLC, TROY, MI. SN 85-109,313. FILED P.R. 8-17-2010; AM. S.R. 5-31-2011.

FOR FRESH FRUIT AND VEGETABLES (U.S. CLS. 1 AND 46).
FIRST USE 4-30-1981; IN COMMERCE 4-17-2008.

CLASS 35—ADVERTISING AND BUSINESS

FOR IMPORT AGENCY SERVICES IN THE FIELD OF FOOD PRODUCTS AND TOBACCO PRODUCTS; WHOLESALE DISTRIBUTORSHIP FEATURING FRUIT, VEGETABLES, TOBACCO PRODUCTS, AND FRESH FRUITS AND VEGETABLES (U.S. CLS. 100, 101 AND 102).

FIRST USE 4-30-1981; IN COMMERCE 4-17-2008.

FOOD PACKAGING TECHNOLOGIES SUMMIT

THE MARK CONSISTS OF STANDARD CHARACTERS WITHOUT CLAIM TO ANY PARTICULAR FONT, STYLE, SIZE, OR COLOR.

OWNER OF U.S. REG. NOS. 1,753,884 AND 3,776,413.

NO CLAIM IS MADE TO THE EXCLUSIVE RIGHT TO USE "SUMMIT", APART FROM THE MARK AS SHOWN.

CLASS 35—ADVERTISING AND BUSINESS

FOR ARRANGING AND CONDUCTING BUSINESS CONFERENCES (U.S. CLS. 100, 101 AND 102).
FIRST USE 4-5-2011; IN COMMERCE 4-5-2011.

CLASS 41—EDUCATION AND ENTERTAINMENT

FOR ARRANGING AND CONDUCTING EDUCATIONAL CONFERENCES (U.S. CLS. 100, 101 AND 107).
FIRST USE 4-5-2011; IN COMMERCE 4-5-2011.

4,017,308. TVN ENTERTAINMENT CORPORATION, SHERMAN OAKS, CA. SN 85-099,037. FILED P.R. 8-3-2010; AM. S.R. 7-20-2011.

FOREIGNFLIX

THE MARK CONSISTS OF STANDARD CHARACTERS WITHOUT CLAIM TO ANY PARTICULAR FONT, STYLE, SIZE, OR COLOR.

CLASS 38—COMMUNICATION

FOR PAY-PER-VIEW TELEVISION TRANSMISSION SERVICES; VIDEO ON DEMAND TRANSMISSION SERVICES; SATELLITE, CABLE, INTERNET PROTOCOL TELEVISION (IPTV) TRANSMISSION SERVICES; TELECOMMUNICATION SERVICES, NAMELY, TRANSMISSION OF VOICE, DATA, GRAPHICS, SOUND AND VIDEO BY MEANS OF BROADBAND POWER LINE OR WIRELESS NETWORKS; TRANSMISSION OF DATA, SOUND AND IMAGES BY SATELLITE (U.S. CLS. 100, 101 AND 104).

FIRST USE 6-2-2010; IN COMMERCE 6-10-2010.

CLASS 41—EDUCATION AND ENTERTAINMENT

FOR PROVISION OF NON-DOWNLOADABLE FILMS AND MOVIES, AND TELEVISION PROGRAMS VIA A VIDEO-ON-DEMAND SERVICE; DISTRIBUTION OF TELEVISION PROGRAMMING TO CABLE TELEVISION SYSTEMS; DISTRIBUTION OF TELEVISION PROGRAMS FOR OTHERS TO CABLE TELEVISION SYSTEMS AND INTERNET PROTOCOL TELEVISION (IPTV) SYSTEMS; CABLE TELEVISION PROGRAMMING; DISTRIBUTION OF TELEVISION PROGRAMS FOR OTHERS TO CABLE TELEVISION SYSTEMS, AND INTERNET PROTOCOL TELEVISION (IPTV) SYSTEMS; DISTRIBUTION OF PAY PER VIEW TELEVISION PROGRAMMING TO CABLE TELEVISION SYSTEMS; DISTRIBUTION OF PAY-PER-VIEW TELEVISION PROGRAMMING TO INTERNET PROTOCOL TELEVISION (IPTV) SYSTEMS; DISTRIBUTION OF MOTION PICTURES (U.S. CLS. 100, 101 AND 107).

FIRST USE 6-2-2010; IN COMMERCE 6-10-2010.

4,017,345. CLARKE, CINDY L.E., DBA OUT OF THE FIRE STUDIO, EDMONTON, ALBERTA, CANADA. AND WILLETT, JIM L., DBA OUT OF THE FIRE STUDIO, EDMONTON, ALBERTA, CANADA. SN 85-141,547. FILED P.R. 9-29-2010; AM. S.R. 7-20-2011.

The Clay Teacher

THE MARK CONSISTS OF STANDARD CHARACTERS WITHOUT CLAIM TO ANY PARTICULAR FONT, STYLE, SIZE, OR COLOR.

PRIORITY CLAIMED UNDER SEC. 44(D) ON CANADA APPLICATION NO. 1465030, FILED 5-5-2010.

CLASS 9—ELECTRICAL AND SCIENTIFIC APPARATUS

FOR DIGITAL MEDIA, NAMELY, PRE-RECORDED VIDEO CASSETTES, DIGITAL VIDEO DISCS, DIGITAL VERSATILE DISCS, DOWNLOADABLE AUDIO AND VIDEO RECORDINGS, DVDS, AND HIGH DEFINITION DIGITAL DISCS FEATURING EDUCATIONAL CONTENT CONSISTING OF INSTRUCTION IN MAKING AND FINISHING CLAY POTTERY AND CLAY SCULPTURE (U.S. CLS. 21, 23, 26, 36 AND 38).

FIRST USE 6-1-2011; IN COMMERCE 6-1-2011.

CLASS 41—EDUCATION AND ENTERTAINMENT

FOR EDUCATIONAL SERVICES, NAMELY, CONDUCTING WORKSHOPS, DEMONSTRATIONS, AND SEMINARS IN THE FIELDS OF CREATING AND FINISHING CLAY POTTERY AND CLAY SCULPTURE AND DISTRIBUTION OF TRAINING MATERIALS IN CONNECTION THEREWITH (U.S. CLS. 100, 101 AND 107).

FIRST USE 7-1-2009; IN COMMERCE 7-1-2009.

4,017,352. ENVIRONMENTAL DESIGN GROUP LLC, LAS VEGAS, NV. SN 85-147,327. FILED P.R. 10-7-2010; AM. S.R. 6-23-2011.

MULTI-GEN

THE MARK CONSISTS OF STANDARD CHARACTERS WITHOUT CLAIM TO ANY PARTICULAR FONT, STYLE, SIZE, OR COLOR.

CLASS 37—CONSTRUCTION AND REPAIR

FOR CONSTRUCTION OF HOUSES, RESIDENTIAL AND/OR COMMERCIAL PROPERTIES; CONSTRUCTION SERVICES, NAMELY, PLANNING, LAYING OUT AND CONSTRUCTION OF RESIDENTIAL AND COMMERCIAL COMMUNITIES; CONSTRUCTION SERVICES, NAMELY, PLANNING, LAYING OUT AND CUSTOM CONSTRUCTION OF RESIDENTIAL AND COMMERCIAL COMMUNITIES; REAL ESTATE DEVELOPMENT (U.S. CLS. 100, 103 AND 106).

FIRST USE 4-25-2011; IN COMMERCE 4-25-2011.

CLASS 42—SCIENTIFIC AND COMPUTER SERVICES

FOR ARCHITECTURAL DESIGN; RESIDENTIAL BUILDING DESIGN (U.S. CLS. 100 AND 101).

FIRST USE 4-25-2011; IN COMMERCE 4-25-2011.
4,017,372. NEDERLANDER ORGANIZATION, INC., NEW YORK, NY. SN 85-181,853. FILED P.R. 11-20-2010; AM. S.R. 6-28-2011.

BROADWAY DIRECT

THE MARK CONSISTS OF STANDARD CHARACTERS WITHOUT CLAIM TO ANY PARTICULAR FONT, STYLE, SIZE, OR COLOR.

CLASS 9—ELECTRICAL AND SCIENTIFIC APPARATUS

FOR DOWNLOADABLE ELECTRONIC NEWSLETTERS IN THE FIELD OF ENTERTAINMENT (U.S. CLS. 21, 23, 26, 36 AND 38).

FIRST USE 5-0-2011; IN COMMERCE 5-0-2011.

CLASS 41—EDUCATION AND ENTERTAINMENT

FOR ON-LINE ELECTRONIC NEWSLETTERS IN THE FIELD OF ENTERTAINMENT (U.S. CLS. 100, 101 AND 107).

FIRST USE 5-0-2011; IN COMMERCE 5-0-2011.

4,017,373. SAFEMINE AG, SCHWYZ, SWITZERLAND. SN 85-183,519. FILED 11-23-2010.

SAFEMINE

THE MARK CONSISTS OF STANDARD CHARACTERS WITHOUT CLAIM TO ANY PARTICULAR FONT, STYLE, SIZE, OR COLOR.

OWNER OF SWITZERLAND REG. NO. 575423, DATED 8-15-2008, EXPIRES 8-11-2018.

CLASS 9—ELECTRICAL AND SCIENTIFIC APPARATUS

FOR VEHICLE SAFETY EQUIPMENT, NAMELY, BACK-UP SENSORS, CAMERAS, ELECTRONIC GLOBAL POSITIONING SYSTEMS DESIGNED TO DETECT MOTION, ANGLE, ROLL-OVER, SPEED, ROAD CONDITIONS, VEHICLES, OBSTACLES AND VEHICLE-VEHICLE AND VEHICLE-OBSTACLE COLLISIONS, AND ELECTRONIC GLOBAL POSITIONING SYSTEMS FOR VEHICLES FOR COLLISION WARNING FOR BRAKING, NAMELY, STOPPING THE VEHICLE, FOR ADAPTING THE SPEED VIA CRUISE CONTROL AND FOR RECORDING EVENTS THAT TRANSPIRE BEFORE A COLLISION PRIMARILY COMPRISING ANTENNAS, TRANSMITTERS, RECEIVERS AND DIGITAL SIGNAL PROCESSORS, IN COMBINATION WITH ALARMS, ELECTRIC ACTUATORS AND ELECTRONIC DATA RECORDERS AND USED TO DETECT VIBRATION, SHOCK, MOTION, ANGLE, ROLL-OVER, SPEED, ROAD CONDITIONS, VEHICLES, OBSTACLES AND VEHICLE-VEHICLE AND VEHICLE OBSTACLE COLLISIONS; POSITIONING SYSTEMS, NAMELY, A BLACK BOX COMPOSED OF ELECTRONIC PARTS IN THE NATURE OF ELECTRONIC PROXIMITY SENSORS, CAMERAS AND ELECTRIC WIRES DESIGNED TO DETECT AND PREVENT VEHICLE-VEHICLE AND VEHICLE-OBSTACLE COLLISIONS; TRAFFIC-LIGHT APPARATUS; SAFETY DEVICES, NAMELY, PAYLOAD PRESSURE SENSORS, SPEEDOMETER AND ANGLE SENSORS FOR USE IN PREVENTING OVERLOADING, ROLLING OVER AND BACK-TRACKING OF TRUCKS; NAVIGATION APPARATUS FOR VEHICLES IN THE FORM OF ON-BOARD COMPUTERS (U.S. CLS. 21, 23, 26, 36 AND 38).

CLASS 39—TRANSPORTATION AND STORAGE

FOR MANAGEMENT OF VEHICULAR TRAFFIC FLOW BY MEANS OF COMMUNICATIONS NETWORKS AND ADVANCED TECHNOLOGY; PROVIDING ROAD AND TRAFFIC INFORMATION SERVICES; TRAFFIC MANAGEMENT SERVICES, NAMELY, MANAGEMENT OF VEHICULAR TRAFFIC FLOW OF A LARGE FLEET OF VARIOUS VEHICLES THROUGH ADVANCED COMMUNICATION NETWORK AND TECHNOLOGY (U.S. CLS. 100 AND 105).

4,017,376. INOUYE, REID, HONOLULU, HI. SN 85-195,501.
FILED P.R. 12-10-2010; AM. S.R. 7-14-2011.

Standup Paddle Magazine

THE MARK CONSISTS OF STANDARD CHARACTERS WITHOUT CLAIM TO ANY PARTICULAR FONT, STYLE, SIZE, OR COLOR.

NO CLAIM IS MADE TO THE EXCLUSIVE RIGHT TO USE "MAGAZINE", APART FROM THE MARK AS SHOWN.

CLASS 16—PAPER GOODS AND PRINTED MATTER

FOR MAGAZINES IN THE FIELD OF STAND UP PADDLE BOARDING (U.S. CLS. 2, 5, 22, 23, 29, 37, 38 AND 50).

FIRST USE 3-0-2009; IN COMMERCE 3-0-2009.

CLASS 25—CLOTHING

FOR BOARD SHORTS; HATS; SHORTS; TEE SHIRTS; VISORS (U.S. CLS. 22 AND 39).

FIRST USE 3-0-2009; IN COMMERCE 3-0-2009.

4,017,382. IKASYSTEMS, SOUTHBOROUGH, MA. SN 85-222,772. FILED P.R. 1-21-2011; AM. S.R. 6-29-2011.

Payer Cloud

THE MARK CONSISTS OF STANDARD CHARACTERS WITHOUT CLAIM TO ANY PARTICULAR FONT, STYLE, SIZE, OR COLOR.

NO CLAIM IS MADE TO THE EXCLUSIVE RIGHT TO USE "CLOUD", APART FROM THE MARK AS SHOWN.

CLASS 35—ADVERTISING AND BUSINESS

FOR MANAGED CARE SERVICES, NAMELY, ELECTRONIC PROCESSING OF HEALTH CARE INFORMATION (U.S. CLS. 100, 101 AND 102).

FIRST USE 1-11-2010; IN COMMERCE 1-11-2010.

CLASS 38—COMMUNICATION

FOR PROVIDING ACCESS TO AN ELECTRONIC EXCHANGE OF MEDICAL RECORDS ACROSS A NATIONWIDE HEALTH INFORMATION NETWORK (U.S. CLS. 100, 101 AND 104).

FIRST USE 1-11-2010; IN COMMERCE 1-11-2010.

CLASS 42—SCIENTIFIC AND COMPUTER SERVICES

FOR COMPUTER SERVICES, NAMELY, REMOTE AND ON-SITE MANAGEMENT OF CLOUD COMPUTING SYSTEMS AND APPLICATIONS FOR OTHERS; COMPUTER SERVICES, NAMELY, CLOUD HOSTING PROVIDER SERVICES; PROVIDING VIRTUAL COMPUTER SYSTEMS AND VIRTUAL COMPUTER ENVIRONMENTS THROUGH CLOUD COMPUTING (U.S. CLS. 100 AND 101).

FIRST USE 1-11-2010; IN COMMERCE 1-11-2010.

4,017,384. BIZNESSCARD LLC, SCOTTSDALE, AZ. SN 85-226,609. FILED P.R. 1-26-2011; AM. S.R. 5-31-2011.

bizzness

THE MARK CONSISTS OF STANDARD CHARACTERS WITHOUT CLAIM TO ANY PARTICULAR FONT, STYLE, SIZE, OR COLOR.

CLASS 35—ADVERTISING AND BUSINESS

FOR CUSTOMER LOYALTY SERVICES AND CUSTOMER CLUB SERVICES, FOR COMMERCIAL, PROMOTIONAL AND/OR ADVERTISING PURPOSES; INFORMATION SERVICES RELATING TO BUSINESS MATTERS; ON-LINE PROFESSIONAL NETWORKING SERVICES; ON-LINE TRADING SERVICES IN WHICH SELLER POSTS PRODUCTS TO BE AUCTIONED AND BIDDING IS DONE VIA THE INTERNET; OPERATING ON-LINE MARKETPLACES FOR SELLERS OF GOODS AND/OR SERVICES; PROMOTING THE GOODS AND SERVICES OF OTHERS VIA A GLOBAL COMPUTER NETWORK; PROVIDING A SEARCHABLE ON-LINE ADVERTISING WEBSITE AND GUIDE FEATURING THE GOODS AND SERVICES OF OTHER VENDORS VIA THE INTERNET; PROVIDING A SEARCHABLE ONLINE ADVERTISING GUIDE FEATURING THE GOODS AND SERVICES OF ONLINE VENDORS; PROVIDING A SEARCHABLE WEBSITE FEATURING THE GOODS AND SERVICES OF OTHER VENDORS; PROVIDING A WEB SITE AT WHICH USERS CAN OFFER GOODS FOR SALE AND BUY GOODS OFFERED BY OTHERS; PROVIDING A WEB SITE WHERE USERS CAN POST RATINGS, REVIEWS AND RECOMMENDATIONS ON PRODUCTS AND SERVICES FOR COMMERCIAL PURPOSES; PROVIDING A WEB SITE WHICH FEATURES ADVERTISEMENTS FOR THE GOODS AND SERVICES OF OTHERS ON A GLOBAL COMPUTER NETWORK; PROVIDING AN ON-LINE SEARCHABLE DATABASE FEATURING BUSINESS INFORMATION AND BUSINESS CONTACTS (U.S. CLS. 100, 101 AND 102).

FIRST USE 3-31-2011; IN COMMERCE 3-31-2011.

CLASS 42—SCIENTIFIC AND COMPUTER SERVICES

FOR PROVIDING CUSTOMIZED ON-LINE WEB PAGES FEATURING USER-DEFINED INFORMATION, WHICH INCLUDES SEARCH ENGINES AND ON-LINE WEB LINKS TO OTHER WEB SITES (U.S. CLS. 100 AND 101).

FIRST USE 3-31-2011; IN COMMERCE 3-31-2011.

4,017,387. JARED FLOOD, LLC, DBA BROOKLYN TWEED, JERSEY CITY, NJ. SN 85-238,290. FILED P.R. 2-9-2011; AM. S.R. 7-18-2011.

4,017,395. CERNA HEALTHCARE, LLC, IRVINE, CA. SN 85-263,455. FILED P.R. 3-10-2011; AM. S.R. 6-20-2011.

BROOKLYN TWEED

THE MARK CONSISTS OF STANDARD CHARACTERS WITHOUT CLAIM TO ANY PARTICULAR FONT, STYLE, SIZE, OR COLOR.

NO CLAIM IS MADE TO THE EXCLUSIVE RIGHT TO USE "TWEED" FOR INTERNATIONAL CLASS 25, APART FROM THE MARK AS SHOWN.

CLASS 16—PAPER GOODS AND PRINTED MATTER

FOR PATTERNS FOR MAKING CLOTHES (U.S. CLS. 2, 5, 22, 23, 29, 37, 38 AND 50). FIRST USE 6-20-2008; IN COMMERCE 8-28-2008.

CLASS 23—YARNS AND THREADS

FOR YARN (U.S. CL. 43). FIRST USE 6-20-2008; IN COMMERCE 10-1-2010.

CLASS 25—CLOTHING

FOR CLOTHING, NAMELY, WRAP-AROUNDS; GLOVES AS CLOTHING; HEADBANDS FOR CLOTHING; HOODS; MUFFLERS; WEARABLE GARMENTS AND CLOTHING, NAMELY, SHIRTS; WOMEN'S CLOTHING, NAMELY, SHIRTS, DRESSES, SKIRTS, BLOUSES; WRAPS (U.S. CLS. 22 AND 39). FIRST USE 6-20-2008; IN COMMERCE 6-20-2008.

CERNA

THE MARK CONSISTS OF STANDARD CHARACTERS WITHOUT CLAIM TO ANY PARTICULAR FONT, STYLE, SIZE, OR COLOR.

CLASS 35—ADVERTISING AND BUSINESS

FOR EMPLOYMENT STAFFING IN THE FIELD OF HEALTHCARE (U.S. CLS. 100, 101 AND 102). FIRST USE 11-0-2010; IN COMMERCE 1-0-2011.

CLASS 45—PERSONAL AND LEGAL SERVICES

FOR PROVIDING NON-MEDICAL IN-HOME PERSONAL SERVICES FOR INDIVIDUALS INCLUDING CHECKING HOME CONDITION, SUPPLIES AND INDIVIDUAL WELL-BEING, SCHEDULING APPOINTMENTS, RUNNING ERRANDS, MAKING SAFETY CHECKS, AND PROVIDING ON-LINE INFORMATION RELATED TO THE PERSONAL SERVICES (U.S. CLS. 100 AND 101). FIRST USE 11-0-2010; IN COMMERCE 1-0-2011.

* * * * *

SECTION 2.— INTERNATIONAL CLASSIFICATION

The short titles associated below with the international class numbers are terms designed merely for quick identification and are not an official part of the international classification. The full names of international classes are given in section 6.1 of the trademark rules of practice.

The designation "U.S. Cl." appearing in this section refers to the U.S. class in effect prior to Sep. 1, 1973 rather than the international class which applies to applications filed on or after that date. For adoption of international classification see notice in the OFFICIAL GAZETTE of Jun. 26, 1973 (911 O.G. TM 210).

Application in one class

CLASS 1—CHEMICALS

4,017,302. SANG BAE HAN, DENVER, CO. SN 85-045,474.
FILED P.R. 5-21-2010; AM. S.R. 6-7-2011.

GREEN PIA

THE MARK CONSISTS OF STANDARD CHARACTERS WITHOUT CLAIM TO ANY PARTICULAR FONT, STYLE, SIZE, OR COLOR.
FOR PLANT FOOD (U.S. CLS. 1, 5, 6, 10, 26 AND 46).
FIRST USE 3-1-2008; IN COMMERCE 3-1-2008.

4,017,327. AB MAURI FOOD INC., CORDOVA, TN. SN 85-125,673. FILED P.R. 9-9-2010; AM. S.R. 6-20-2011.

BAKER'S BEST

THE MARK CONSISTS OF STANDARD CHARACTERS WITHOUT CLAIM TO ANY PARTICULAR FONT, STYLE, SIZE, OR COLOR.
OWNER OF U.S. REG. NO. 3,257,252.
FOR CHEMICAL FOOD ADDITIVES, PRESERVATIVES AND INGREDIENTS USED IN THE MANUFACTURE OF BAKERY GOODS, NAMELY, DOUGH IMPROVERS, DOUGH LEAVENERS, MOLD INHIBITORS, ACIDULANTS, MINERAL SALTS, GUMS, OXIDATION AGENTS, AND ENZYME TABLETS (U.S. CLS. 1, 5, 6, 10, 26 AND 46).
FIRST USE 12-20-2010; IN COMMERCE 12-20-2010.

CLASS 1—(Continued).

4,017,410. NATURAL POOL PRODUCTS, INC., MCKINNEY, TX. SN 85-277,593. FILED P.R. 3-25-2011; AM. S.R. 6-22-2011.

**Naturally PureSPA Enzyme
Cleaner & Phosphate Control**

THE MARK CONSISTS OF STANDARD CHARACTERS WITHOUT CLAIM TO ANY PARTICULAR FONT, STYLE, SIZE, OR COLOR.

NO CLAIM IS MADE TO THE EXCLUSIVE RIGHT TO USE "SPA ENZYME CLEANER & PHOSPHATE CONTROL", APART FROM THE MARK AS SHOWN.

FOR WATER PURIFYING CHEMICALS FOR SWIMMING POOLS; WATER TREATMENT CHEMICALS FOR USE IN SWIMMING POOLS AND SPAS (U.S. CLS. 1, 5, 6, 10, 26 AND 46).

FIRST USE 6-1-2010; IN COMMERCE 6-1-2010.

CLASS 3—COSMETICS AND CLEANING PREPARATIONS

4,017,377. OLE HENRIKSEN OF DENMARK, INC., LOS ANGELES, CA. SN 85-196,404. FILED P.R. 12-13-2010; AM. S.R. 7-15-2011.

solar active complex

THE MARK CONSISTS OF STANDARD CHARACTERS WITHOUT CLAIM TO ANY PARTICULAR FONT, STYLE, SIZE, OR COLOR.

FOR NON-MEDICATED SKIN CARE PREPARATIONS (U.S. CLS. 1, 4, 6, 50, 51 AND 52).

FIRST USE 4-30-2011; IN COMMERCE 4-30-2011.

CLASS 5—PHARMACEUTICALS

CLASS 5—(Continued).

4,017,291. IOFINA NATURAL GAS, INC., GREENWOOD VILLAGE, CO. SN 77-937,810. FILED P.R. 2-17-2010; AM. S.R. 12-15-2010.

CLASS 9—(Continued).

4,017,278. FLUID OPERATIONS GMBH, WALLDORF, FED REP GERMANY. SN 77-786,319. FILED P.R. 7-21-2009; AM. S.R. 3-29-2011.

TECHNOLOGY LEADERS IN IODINE

THE MARK CONSISTS OF STANDARD CHARACTERS WITHOUT CLAIM TO ANY PARTICULAR FONT, STYLE, SIZE, OR COLOR.

FOR IODINE (U.S. CLS. 6, 18, 44, 46, 51 AND 52).
FIRST USE 11-18-2010; IN COMMERCE 11-18-2010.

eCloudManager

THE MARK CONSISTS OF STANDARD CHARACTERS WITHOUT CLAIM TO ANY PARTICULAR FONT, STYLE, SIZE, OR COLOR.

FOR COMPUTER SOFTWARE FOR APPLICATION AND DATABASE INTEGRATION; COMPUTER SOFTWARE FOR COMPUTER SYSTEM AND APPLICATION DEVELOPMENT, DEPLOYMENT AND MANAGEMENT; COMPUTER SOFTWARE FOR CONTROLLING AND MANAGING ACCESS SERVER APPLICATIONS; COMPUTER SOFTWARE THAT ASSISTS COMPUTERS IN DEPLOYING PARALLEL APPLICATIONS AND PERFORMING PARALLEL COMPUTATIONS; COMPUTER SOFTWARE THAT PROVIDES REAL-TIME, INTEGRATED BUSINESS MANAGEMENT INTELLIGENCE BY COMBINING INFORMATION FROM VARIOUS DATABASES AND PRESENTING IT IN AN EASY-TO-UNDERSTAND USER INTERFACE; COMPUTER SOFTWARE THAT PROVIDES WEB-BASED ACCESS TO APPLICATIONS AND SERVICES THROUGH A WEB OPERATING SYSTEM OR PORTAL INTERFACE; GRAPHICAL USER INTERFACE SOFTWARE (U.S. CLS. 21, 23, 26, 36 AND 38).

FIRST USE 2-15-2009; IN COMMERCE 5-26-2009.

4,017,298. OMS INVESTMENTS, INC., LOS ANGELES, CA. SN 85-008,906. FILED P.R. 4-7-2010; AM. S.R. 7-11-2011.

TOUCH UP

THE MARK CONSISTS OF STANDARD CHARACTERS WITHOUT CLAIM TO ANY PARTICULAR FONT, STYLE, SIZE, OR COLOR.

FOR HERBICIDES FOR DOMESTIC USE (U.S. CLS. 6, 18, 44, 46, 51 AND 52).
FIRST USE 3-5-2011; IN COMMERCE 3-5-2011.

CLASS 6—METAL GOODS

4,017,375. PHOTOFLEX, INC., WATSONVILLE, CA. SN 85-193,583. FILED P.R. 12-8-2010; AM. S.R. 6-21-2011.

GRIPJAW

THE MARK CONSISTS OF STANDARD CHARACTERS WITHOUT CLAIM TO ANY PARTICULAR FONT, STYLE, SIZE, OR COLOR.

FOR METAL CLAMP-TYPE FASTENERS FOR HOLDING IN PLACE CURTAINS, TARPS, CANVAS, CLOTH AND FILM COVERING MATERIAL; METAL CLAMPS (U.S. CLS. 2, 12, 13, 14, 23, 25 AND 50).

FIRST USE 5-28-2010; IN COMMERCE 5-28-2010.

4,017,281. KENWORTHY, NANCY, FAR HILLS, NJ. SN 77-817,384. FILED P.R. 9-1-2009; AM. S.R. 10-27-2010.

ONE DOLLAR AT A TIME

THE MARK CONSISTS OF STANDARD CHARACTERS WITHOUT CLAIM TO ANY PARTICULAR FONT, STYLE, SIZE, OR COLOR.

FOR DECORATIVE MAGNETS (U.S. CLS. 21, 23, 26, 36 AND 38).
FIRST USE 12-0-2009; IN COMMERCE 12-0-2009.

CLASS 9—ELECTRICAL AND SCIENTIFIC APPARATUS

CLASS 9—(Continued).

4,017,284. TWENTIETH CENTURY FOX FILM CORPORATION, LOS ANGELES, CA. SN 77-858,758. FILED P.R. 10-27-2009; AM. S.R. 2-15-2011.

LIVE LOOKUP

THE MARK CONSISTS OF STANDARD CHARACTERS WITHOUT CLAIM TO ANY PARTICULAR FONT, STYLE, SIZE, OR COLOR.

FOR SOFTWARE ENABLING USERS TO OBTAIN INFORMATION FEATURING MOTION PICTURE FILM AND VIDEO ENTERTAINMENT VIA A GLOBAL COMPUTER NETWORK; SOFTWARE ENABLING USERS TO OBTAIN INFORMATION ABOUT MOTION PICTURE FILM ENTERTAINMENT SOLD AS AN INTEGRAL COMPONENT OF PRE-RECORDED DVDS FEATURING MOTION PICTURE FILMS (U.S. CLS. 21, 23, 26, 36 AND 38).

FIRST USE 9-15-2009; IN COMMERCE 9-15-2009.

4,017,286. ATLANCO, INC., MARIETTA, GA. SN 77-896,842. FILED P.R. 12-18-2009; AM. S.R. 4-22-2011.

INTERLOCK

THE MARK CONSISTS OF STANDARD CHARACTERS WITHOUT CLAIM TO ANY PARTICULAR FONT, STYLE, SIZE, OR COLOR.

FOR PROTECTIVE CLOTHING (U.S. CLS. 21, 23, 26, 36 AND 38).

FIRST USE 4-28-2010; IN COMMERCE 4-28-2010.

4,017,295. WAVETRONIX LLC, LINDON, UT. SN 78-644,656. FILED 6-6-2005.

SMARTSENSOR

THE MARK CONSISTS OF STANDARD CHARACTERS WITHOUT CLAIM TO ANY PARTICULAR FONT, STYLE, SIZE, OR COLOR.

OWNER OF U.S. REG. NO. 3,348,944.
FOR SELF-CONTAINED, USER CONFIGURABLE TRAFFIC SENSOR, POSITIONABLE TO SENSE AND MEASURE SPEED, OCCUPANCY, VOLUME, AND PRESENCE OF MULTIPLE TRAFFIC LANES FROM A REMOTE LOCATION (U.S. CLS. 21, 23, 26, 36 AND 38).

FIRST USE 9-30-2001; IN COMMERCE 9-30-2001.

CLASS 9—(Continued).

4,017,310. INNOVATIVE LIGHTING INC., ROLAND, IA. SN 85-102,134. FILED P.R. 8-6-2010; AM. S.R. 7-13-2011.

**Precision Optical
Performance**

THE MARK CONSISTS OF STANDARD CHARACTERS WITHOUT CLAIM TO ANY PARTICULAR FONT, STYLE, SIZE, OR COLOR.

FOR AUTOMOTIVE, INDUSTRIAL, CONSTRUCTION, LOCOMOTIVE, AVIATION, NAVIGATION AND MARINE SAFETY-WARNING LIGHTS, NAMELY, STROBES, ROTATING LIGHTS AND BAR LIGHTS; ELECTRICAL LIGHTS FOR USE IN PROFESSIONAL QUALITY PHOTOGRAPHY; ELECTRONIC REGULATING AND CONTROL DEVICES FOR THE OPERATION OF LIGHT EMITTING DIODES; LED AND HID LIGHT CONTROLS; LIGHT DIODES; LIGHT EMITTING DIODES (LEDs); LIGHTING CONTROLS; MOTION SENSITIVE SECURITY LIGHTS (U.S. CLS. 21, 23, 26, 36 AND 38).

FIRST USE 3-20-2010; IN COMMERCE 4-15-2010.

4,017,315. CATALYST SYSTEMS CORPORATION, DBA OPENMAKE SOFTWARE, CHICAGO, IL. SN 85-110,753. FILED P.R. 8-18-2010; AM. S.R. 6-17-2011.

CloudBuilder

THE MARK CONSISTS OF STANDARD CHARACTERS WITHOUT CLAIM TO ANY PARTICULAR FONT, STYLE, SIZE, OR COLOR.

FOR COMPUTER SOFTWARE FOR USE IN AUTOMATICALLY ROUTING SOFTWARE BUILDS TO ANY AVAILABLE MACHINE (U.S. CLS. 21, 23, 26, 36 AND 38).

FIRST USE 2-22-2011; IN COMMERCE 2-22-2011.

CLASS 9—(Continued).

4,017,321. SAVKIN, ALEKSEY, SERPUKHOV, RUSSIAN FED.. SN 85-119,960. FILED P.R. 8-31-2010; AM. S.R. 7-14-2011.

BSC Designer

THE MARK CONSISTS OF STANDARD CHARACTERS WITHOUT CLAIM TO ANY PARTICULAR FONT, STYLE, SIZE, OR COLOR.

FOR DOWNLOADABLE COMPUTER SOFTWARE AND COMPUTER SOFTWARE RECORDED ON CD-ROM OR DVD FOR CREATING, MODIFYING, MONITORING AND DESIGNING ORGANIZATIONAL AND BUSINESS PERFORMANCE INDICATORS, CREATING PERFORMANCE INDICATORS' REPORTS, AND OPTIMIZING, MONITORING, AND MEASURING BUSINESS PERFORMANCE AND INCREASING BUSINESS PRODUCTIVITY (U.S. CLS. 21, 23, 26, 36 AND 38).

FIRST USE 6-18-2007; IN COMMERCE 6-18-2007.

4,017,323. ABYSS GROUP INC, STAMFORD, CT. SN 85-123,161. FILED P.R. 9-3-2010; AM. S.R. 6-15-2011.

iGLOSSARY

THE MARK CONSISTS OF STANDARD CHARACTERS WITHOUT CLAIM TO ANY PARTICULAR FONT, STYLE, SIZE, OR COLOR.

FOR SOFTWARE THAT ENABLES USERS TO CREATE, MANAGE, SHARE AND SEARCH COMMON ENTERPRISE VOCABULARY, TERMS AND CLASSIFICATION SYSTEM (U.S. CLS. 21, 23, 26, 36 AND 38).

FIRST USE 9-1-2010; IN COMMERCE 9-1-2010.

4,017,343. ISCRROLL INC, ROCKVILLE, MD. SN 85-140,218. FILED P.R. 9-28-2010; AM. S.R. 4-26-2011.

iScroll

THE MARK CONSISTS OF STANDARD CHARACTERS WITHOUT CLAIM TO ANY PARTICULAR FONT, STYLE, SIZE, OR COLOR.

FOR COMPUTER APPLICATION SOFTWARE FOR MOBILE PHONES, NAMELY, SOFTWARE FOR CONTROLLING AND DISPLAYING TEXT FILES, IMAGES AND GRAPHICS (U.S. CLS. 21, 23, 26, 36 AND 38).

FIRST USE 8-1-2008; IN COMMERCE 11-1-2008.

CLASS 9—(Continued).

4,017,364. CBUS WIRELESS, LLC, COLUMBUS, OH. SN 85-172,821. FILED P.R. 11-9-2010; AM. S.R. 7-7-2011.

CBUS WIRELESS

NO CLAIM IS MADE TO THE EXCLUSIVE RIGHT TO USE "WIRELESS" AS TO "BROADBAND WIRELESS EQUIPMENT, NAMELY, TELECOMMUNICATIONS BASE STATION EQUIPMENT FOR CELLULAR AND FIXED NETWORKING AND COMMUNICATIONS APPLICATIONS; CELL PHONE BATTERY CHARGERS; CELL PHONE BATTERY CHARGERS FOR USE IN VEHICLES; CELL PHONE HAVING LARGE KEYS AND NUMBERS THAT ASSIST USERS HAVING IMPAIRED VISION OR DEXTERITY; CELL PHONES; CELLULAR PHONE USAGE DETECTION SYSTEM COMPRISING A CAMERA AND A MOBILE PHONE SIGNAL RECEIVING DEVICE; CELLULAR PHONES; CELLULAR TELEPHONE APPARATUS; CELLULAR TELEPHONES; DEVICES FOR HANDS-FREE USE OF MOBILE PHONES; DIGITAL CELLULAR PHONES; EAR PHONES; HANDS FREE DEVICES FOR MOBILE PHONES; HANDS FREE KITS FOR PHONES; HEADSETS FOR CELLULAR OR MOBILE PHONES; INTERNET PHONES; INTEROPERABLE COMMUNICATION SYSTEM DESIGNED TO PROVIDE RADIO, STREAMING VIDEO, WIRELESS INTERNET, AND VOIP PHONE; KEYBOARDS FOR MOBILE PHONES; MOBILE PHONES; VIDEO PHONES; WIRELESS CELLULAR PHONE HEADSETS", APART FROM THE MARK AS SHOWN.

THE MARK CONSISTS OF THE STYLIZED WORDING "CBUS WIRELESS".

FOR BAGS AND CASES SPECIALLY ADAPTED FOR HOLDING OR CARRYING PORTABLE TELEPHONES AND TELEPHONE EQUIPMENT AND ACCESSORIES; BATTERY CASES; BEEPER CARRYING CASES; BROADBAND WIRELESS EQUIPMENT, NAMELY, TELECOMMUNICATIONS BASE STATION EQUIPMENT FOR CELLULAR AND FIXED NETWORKING AND COMMUNICATIONS APPLICATIONS; CAMERA CASES; CARRYING CASES FOR CELL PHONES; CARRYING CASES FOR MOBILE COMPUTERS; CARRYING CASES SPECIALLY ADAPTED FOR POCKET CALCULATORS AND CELLPHONES; CARRYING CASES, HOLDERS, PROTECTIVE CASES AND STANDS FEATURING POWER SUPPLY CONNECTORS, ADAPTORS, SPEAKERS AND BATTERY CHARGING DEVICES, SPECIALLY ADAPTED FOR USE WITH HANDHELD DIGITAL ELECTRONIC DEVICES; CASES FOR DISKETTES AND COMPACT DISKS; CASES FOR MOBILE PHONES; CASES FOR TELEPHONES; CD CASES; CELL PHONE BATTERY CHARGERS; CELL PHONE BATTERY CHARGERS FOR USE IN VEHICLES; CELL PHONE CASES; CELL PHONE COVERS; CELL PHONE FACEPLATES; CELL PHONE HAVING LARGE KEYS AND NUMBERS THAT ASSIST USERS HAVING IMPAIRED VISION OR DEXTERITY; CELL PHONES; CELLULAR PHONE ACCESSORY CHARGES; CELLULAR PHONE USAGE DETECTION SYSTEM COMPRISING A CAMERA AND A MOBILE PHONE SIGNAL RECEIVING DEVICE; CELLULAR PHONES; CELLULAR TELEPHONE APPARATUS; CELLULAR TELEPHONES; COMPUTER CARRYING CASES; COMPUTER GAME SOFTWARE FOR USE ON MOBILE AND CELLULAR PHONES; DEVICES FOR HANDS-FREE USE OF MOBILE PHONES; DIGITAL CELLULAR PHONES; EAR PHONES; EARPHONE ACCESSORIES, NAMELY, EARPHONE CUSHIONS, EARPHONE PADS, CORD MANAGEMENT SYSTEMS, EARPHONE CASES, AND EARPHONE EXTENSION CORDS; ELECTRONIC GAME SOFTWARE FOR CELLULAR TELEPHONES; FITTED PLASTIC FILMS KNOWN AS SKINS FOR COVERING AND PROTECTING ELECTRONIC APPARATUS, NAMELY, CELLULAR PHONES, AND MP3 PLAYERS; HANDS FREE DEVICES FOR MOBILE-PHONES; HANDS FREE KITS FOR PHONES; HEAD-CLIP CELL PHONE HOLDERS; HEADSETS FOR CELLULAR OR MOBILE

CLASS 9—(Continued).

PHONES; INTERNET PHONES; INTEROPERABLE COMMUNICATION SYSTEM DESIGNED TO PROVIDE RADIO, STREAMING VIDEO, WIRELESS INTERNET, AND VOIP PHONE; KEYBOARDS FOR MOBILE PHONES; LAPTOP CARRYING CASES; MOBILE PHONE STRAPS; MOBILE PHONES; NOTEBOOK COMPUTER CARRYING CASES; PROTECTIVE CARRYING CASES FOR PORTABLE MUSIC PLAYERS, NAMELY, MP3 PLAYERS; PROTECTIVE CARRYING CASES SPECIALLY ADAPTED FOR GLOBAL POSITIONING SYSTEM (GPS) APPARATUS; PROTECTIVE CARRYING CASES SPECIALLY ADAPTED FOR PERSONAL DIGITAL ASSISTANTS (PDA); PROTECTIVE CARRYING CASES SPECIALLY ADAPTED FOR VIDEO GAME CONSOLES FOR USE WITH AN EXTERNAL DISPLAY SCREEN OR MONITOR; PROTECTIVE COVERS AND CASES FOR CELL PHONES, LAPTOPS AND PORTABLE MEDIA PLAYERS; SPECIALTY HOLSTER FOR CARRYING CELLULAR PHONES; STRAPS FOR MOBILE PHONES; VIDEO PHONES; VINYL COVERS SPECIALLY ADAPTED FOR CELL PHONES, MP3 PLAYERS, LAPTOPS, COMPUTERS, PORTABLE SATELLITE RADIOS, PERSONAL DIGITAL ASSISTANTS, REMOTE CONTROLS, AND TELEVISION SATELLITE RECORDERS; WIRELESS CELLULAR PHONE HEADSETS (U.S. CLS. 21, 23, 26, 36 AND 38).
FIRST USE 10-5-2010; IN COMMERCE 10-5-2010.

4,017,400. GLOBAL SECURITY TRACKING, INC., WORCESTER, MA. SN 85-267,454. FILED P.R. 3-15-2011; AM. S.R. 6-20-2011.

GLOBAL SECURITY TRACKING

THE MARK CONSISTS OF STANDARD CHARACTERS WITHOUT CLAIM TO ANY PARTICULAR FONT, STYLE, SIZE, OR COLOR.
NO CLAIM IS MADE TO THE EXCLUSIVE RIGHT TO USE "TRACKING", APART FROM THE MARK AS SHOWN, FOR GLOBAL POSITIONING SYSTEM (GPS) (U.S. CLS. 21, 23, 26, 36 AND 38).
FIRST USE 11-0-2005; IN COMMERCE 11-0-2005.

CLASS 10—MEDICAL APPARATUS

4,017,299. EXSILENT BV, AMSTERDAM, NETHERLANDS. SN 85-009,168. FILED P.R. 4-8-2010; AM. S.R. 7-4-2011.

MARIC

THE MARK CONSISTS OF STANDARD CHARACTERS WITHOUT CLAIM TO ANY PARTICULAR FONT, STYLE, SIZE, OR COLOR.
FOR HEARING AIDS (U.S. CLS. 26, 39 AND 44).
FIRST USE 10-10-2010; IN COMMERCE 5-10-2011.

CLASS 10—(Continued).

4,017,309. HILL-ROM SERVICES, INC., BATESVILLE, IN. SN 85-101,014. FILED P.R. 8-5-2010; AM. S.R. 6-8-2011.

COUGH PAUSE

THE MARK CONSISTS OF STANDARD CHARACTERS WITHOUT CLAIM TO ANY PARTICULAR FONT, STYLE, SIZE, OR COLOR.
FOR MEDICAL APPARATUS, NAMELY, PROGRAMMABLE TREATMENT TIMER SOLD AS A FEATURE OF A DEVICE FOR AIRWAY CLEARANCE THERAPY (U.S. CLS. 26, 39 AND 44).
FIRST USE 7-15-2010; IN COMMERCE 7-15-2010.

4,017,356. RANIR, LLC, GRAND RAPIDS, MI. SN 85-156,648. FILED P.R. 10-20-2010; AM. S.R. 7-19-2011.

CLINICAL GRADE

THE MARK CONSISTS OF STANDARD CHARACTERS WITHOUT CLAIM TO ANY PARTICULAR FONT, STYLE, SIZE, OR COLOR.
FOR DENTAL INSTRUMENTS, NAMELY, SCALERS, MIRRORS, AND PICKS; AND TONGUE CLEANERS (U.S. CLS. 26, 39 AND 44).
FIRST USE 8-23-2010; IN COMMERCE 8-23-2010.

4,017,374. ASCEND EAGLE, INC, AMERICAN CANYON, CA. SN 85-192,350. FILED P.R. 12-7-2010; AM. S.R. 7-8-2011.

UberSlim

THE MARK CONSISTS OF STANDARD CHARACTERS WITHOUT CLAIM TO ANY PARTICULAR FONT, STYLE, SIZE, OR COLOR.
FOR DENTAL GLOVES; GLOVES FOR MEDICAL PURPOSES; MEDICAL EXAMINATION GLOVES; NITRILE GLOVES FOR MEDICAL USE (U.S. CLS. 26, 39 AND 44).
FIRST USE 12-1-2010; IN COMMERCE 12-1-2010.

CLASS 11—ENVIRONMENTAL CONTROL APPARATUS

CLASS 11—(Continued).

4,017,279. HUBMAR INTERNATIONAL INC., ST-LAURENT, CANADA. SN 77-794,396. FILED P.R. 7-31-2009; AM. S.R. 6-23-2011.

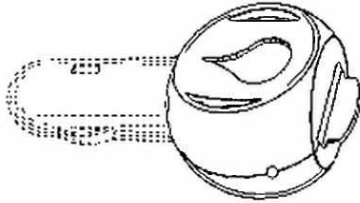

THE MARK CONSISTS OF A THREE-DIMENSIONAL CONFIGURATION OF A CAR AROMATHERAPY AND AIR FRESHENER DISPENSING UNIT. THE SPHERICAL PORTION OF THE DISPENSING UNIT WITH A CONCAVE SIDE FEATURING A TEAR-SHAPED CUTOUT IN THE CENTER WITH TWO SEMI-CIRCULAR CUTOUTS ON EITHER SIDE, AND WITH A FLATTENED TOP PORTION WHERE A TONGUE PROTRUDES ADJACENT TO A SLIT, ARE CLAIMED AS A FEATURE OF THE MARK. THE 12 VOLT PLUG PORTION OF THE CONFIGURATION OF THE DISPENSING UNIT IS SHOWN IN BROKEN OR DOTTED LINES IS NOT PART OF THE MARK AND SERVES ONLY TO SHOW POSITION OR PLACEMENT OF THE MARK. THE LINING IS NOT A FEATURE OF THE MARK AND IS FOR SHADING PURPOSES ONLY.

FOR DISPENSING UNITS FOR CAR AIR FRESHENERS (U.S. CLS. 13, 21, 23, 31 AND 34).

FIRST USE 12-15-1998; IN COMMERCE 12-15-1998.

CLASS 15—MUSICAL INSTRUMENTS

4,017,418. PAUL SPEAKMAN, LOS ANGELES, CA. SN 85-289,357. FILED P.R. 4-7-2011; AM. S.R. 7-15-2011.

THE MARK CONSISTS OF THE WORDING "SPEAKMAN" IN STYLIZED FONT.

FOR GUITARS (U.S. CLS. 2, 21 AND 36).

FIRST USE 4-2-2011; IN COMMERCE 4-2-2011.

CLASS 16—PAPER GOODS AND PRINTED MATTER**CLASS 16—(Continued).**

4,017,346. YOSEMITE FOUNDATION, SAN FRANCISCO, CA. SN 85-143,303. FILED P.R. 10-1-2010; AM. S.R. 6-10-2011.

YOSEMITE CONSERVANCY

THE MARK CONSISTS OF STANDARD CHARACTERS WITHOUT CLAIM TO ANY PARTICULAR FONT, STYLE, SIZE, OR COLOR.

OWNER OF U.S. REG. NO. 3,190,567.

FOR GREETING CARDS; HOLIDAY CARDS; POSTCARDS; PRINTED ART REPRODUCTIONS; CALENDARS; POSTERS, MAPS; BOOKS, BOOKLETS, PAMPHLETS, MAGAZINES AND NEWSLETTERS ALL IN THE FIELDS OF CONSERVATION OF NATURAL RESOURCES, BIOLOGY, BOTANY, ART, PHOTOGRAPHY, AND HISTORY (U.S. CLS. 2, 5, 22, 23, 29, 37, 38 AND 50).

FIRST USE 9-27-2010; IN COMMERCE 9-27-2010.

4,017,379. GREEN HILL HEALTHCARE COMMUNICATIONS, LLC, MONROE TOWNSHIP, NJ. SN 85-213,695. FILED P.R. 1-10-2011; AM. S.R. 7-7-2011.

THE ONCOLOGY NURSE-APN/PA

THE MARK CONSISTS OF STANDARD CHARACTERS WITHOUT CLAIM TO ANY PARTICULAR FONT, STYLE, SIZE, OR COLOR.

OWNER OF U.S. REG. NOS. 3,621,208 AND 3,624,945.

FOR PRINTED PUBLICATIONS, NAMELY, PEER REVIEWED MEDICAL MAGAZINES, JOURNALS, NEWSLETTERS, FEATURE REPORTS, MONOGRAPHS, AND PRINTED SUPPLEMENTS TO THE FOREGOING IN THE FIELDS OF HEMATOLOGY, ONCOLOGY AND NURSING (U.S. CLS. 2, 5, 22, 23, 29, 37, 38 AND 50).

FIRST USE 6-1-2010; IN COMMERCE 6-1-2010.

4,017,383. KID KNOWLEDGE, INC, ARMONK, NY. SN 85-225,186. FILED P.R. 1-25-2011; AM. S.R. 7-12-2011.

STEM KIT

THE MARK CONSISTS OF STANDARD CHARACTERS WITHOUT CLAIM TO ANY PARTICULAR FONT, STYLE, SIZE, OR COLOR.

CLASS 16—(Continued).

NO CLAIM IS MADE TO THE EXCLUSIVE RIGHT TO USE "KIT", APART FROM THE MARK AS SHOWN.

FOR EDUCATIONAL KITS SOLD AS A UNIT IN THE FIELD OF VARIOUS SCIENCES, ASTRONOMY, MEASUREMENT, MATH, ENGINEERING AND TECHNOLOGY, CONSISTING PRIMARILY OF PRINTED INSTRUCTIONAL MATERIALS AND ALSO INCLUDING ARTIFACTS (U.S. CLS. 2, 5, 22, 23, 29, 37, 38 AND 50).

FIRST USE 12-30-2010; IN COMMERCE 1-10-2011.

**MISSION INFORMATION
RESOURCES**

4,017,415. MISSION INFORMATION RESOURCES, INC., LANCASTER, NH. SN 85-282,987. FILED P.R. 3-31-2011; AM. S.R. 7-13-2011.

THE MARK CONSISTS OF STANDARD CHARACTERS WITHOUT CLAIM TO ANY PARTICULAR FONT, STYLE, SIZE, OR COLOR.

FOR MANUALS IN THE FIELD OF COMBAT, TACTICAL, LOGISTICAL AND/OR RESCUE OPERATIONS (U.S. CLS. 2, 5, 22, 23, 29, 37, 38 AND 50).

FIRST USE 11-17-1999; IN COMMERCE 7-31-2000.

CLASS 19—NON-METALLIC BUILDING MATERIALS

4,017,296. ANCHOR WALL SYSTEMS, INC., MINNETONKA, MN. SN 85-000,598. FILED P.R. 3-29-2010; AM. S.R. 7-11-2011.

LEDGEWALL

THE MARK CONSISTS OF STANDARD CHARACTERS WITHOUT CLAIM TO ANY PARTICULAR FONT, STYLE, SIZE, OR COLOR.

FOR CONCRETE BLOCKS (U.S. CLS. 1, 12, 33 AND 50).
FIRST USE 2-28-2010; IN COMMERCE 2-28-2010.

CLASS 19—(Continued).

4,017,336. HH TECHNOLOGIES, INC., BREMEN, AL. SN 85-128,240. FILED P.R. 9-13-2010; AM. S.R. 6-2-2011.

DOCK SHADE

THE MARK CONSISTS OF STANDARD CHARACTERS WITHOUT CLAIM TO ANY PARTICULAR FONT, STYLE, SIZE, OR COLOR.

FOR NONMETAL PROTECTION SCREENS FOR ATTACHMENT TO OUTDOOR STRUCTURES FOR PROTECTING OBJECTS LOCATED THEREIN AGAINST STRONG WINDS AND DIRECT SUNLIGHT AND RAIN, NAMELY, FOR ATTACHMENT TO DOCKS TO PROTECT BOATS AND OTHER WATERCRAFT OR FURNITURE LOCATED THEREIN (U.S. CLS. 1, 12, 33 AND 50).

FIRST USE 3-15-2010; IN COMMERCE 3-15-2010.

4,017,350. DALTON ENTERPRISES, INC., CHESHIRE, CT. SN 85-145,895. FILED P.R. 10-6-2010; AM. S.R. 7-11-2011.

**THE LEADER IN DRIVEWAY
MAINTENANCE**

THE MARK CONSISTS OF STANDARD CHARACTERS WITHOUT CLAIM TO ANY PARTICULAR FONT, STYLE, SIZE, OR COLOR.

FOR COATINGS COMPOSED OF ASPHALT AND POLYMER-MODIFIED RESIN COMPOUNDS FOR USE AS A PATCH AND SEALANT ON BITUMINOUS PAVEMENT SURFACES (U.S. CLS. 1, 12, 33 AND 50).

FIRST USE 6-1-2010; IN COMMERCE 6-1-2010.

CLASS 21—HOUSEWARES AND GLASS

CLASS 21—(Continued).

4,017,341. EAGLE HOME PRODUCTS, INC., HUNTINGTON, NY. SN 85-137,421. FILED P.R. 9-24-2010; AM. S.R. 6-23-2011.



THE MARK CONSISTS OF STYLIZED SCROLL DESIGNS FORMING INCOMPLETE HEARTS PRESENTED VERTICALLY AS MIRRORED IMAGES WITH SIXTEEN CURVED LINES EMANATING THEREFROM AND TWO FOUR-POINTED STARS SHOWN THEREIN SURROUNDED BY FOUR GEOMETRIC SHAPES COMPRISED OF THREE ELONGATED LINES CONNECTED AT THE BOTTOM ALL DISPLAYED IN A REPETITIVE PATTERN.

FOR BROOMS; DISHWASHING BRUSHES; DUST-PANS; MOPS; PLASTIC BUCKETS; TOILET BRUSHES (U.S. CLS. 2, 13, 23, 29, 30, 33, 40 AND 50).

FIRST USE 3-15-2010; IN COMMERCE 3-15-2010.

4,017,347. EAGLE HOME PRODUCTS, INC., HUNTINGTON, NY. SN 85-143,388. FILED P.R. 10-1-2010; AM. S.R. 6-23-2011.



THE COLOR(S) YELLOW, GREEN, ORANGE, WHITE AND BLACK IS/ARE CLAIMED AS A FEATURE OF THE MARK.

THE MARK CONSISTS OF STYLIZED IMAGES OF MULTIPLE YELLOW, ORANGE AND BLACK OUTLINED FLOWERS ON A WHITE BACKGROUND WITH GREEN LEAVES EMERGING FROM SOME FLOWERS ALL DISPLAYED IN A REPETITIVE PATTERN.

FOR BROOMS; DISHWASHING BRUSHES; DUST PANS; MOPS; PLASTIC BUCKETS; TOILET BRUSHES (U.S. CLS. 2, 13, 23, 29, 30, 33, 40 AND 50).

FIRST USE 3-15-2010; IN COMMERCE 3-15-2010.

CLASS 25—CLOTHING**CLASS 25—(Continued).**

4,017,272. HORN, SEAN PATRICK, COUNCIL BLUFFS, IA. SN 76-686,233. FILED P.R. 1-28-2008; AM. S.R. 7-13-2011.



THE COLOR(S) DARK YELLOW, LIGHT BROWN, BLACK, WHITE, BLUE, RED, YELLOW, ORANGE, PURPLE AND GREEN IS/ARE CLAIMED AS A FEATURE OF THE MARK.

THE MARK CONSISTS OF DARK YELLOW SUN WITH LIGHT BROWN TRIMMING. THE SUN HAS A SMILE WITH BLACK TRIMMING. THE SUN IS LOCATED ON THE TOP RIGHT HAND SIDE OF THE DRAWING. UNDERNEATH IS A RAINBOW WITH THE SLOGAN "HI, I'M THE NEW GIFT IN THE FAMILY!" ON TOP OF THE RAINBOW, WITH WHITE CLOUDS AT THE BEGINNING AND THE END OF THE RAINBOW WITH AN ABSTRACT LOVE SYMBOL CENTERED BELOW THE RAINBOW AND BETWEEN THE CLOUDS. THE RAINBOWS HAS COLORS, FROM TOP TO BOTTOM, WHICH ARE YELLOW, ORANGE, RED, PURPLE, GREEN, LIGHT BLUE. THE TWO CLOUDS ARE WHITE WITH BLACK TRIMMING OUTSIDE WITH LIGHT BLUE TRIMMING INSIDE CLOSE TO THE BOTTOM OF BOTH CLOUDS. IN THE ABSTRACT LOVE SYMBOL CONSISTING OF THE WORDING "LOVE" THE LETTERS OF THE WORD ARE RED. THE "L" LOOKS LIKE A HEART WITH THE LETTERS "OVE" INSIDE OF IT. "HI, I'M THE NEW GIFT IN THE FAMILY!" APPEARS IN ALL BLACK. A SMALL RED HEART CONSTITUTES AN APOSTROPHE BETWEEN THE LETTERS "I" AND "M" IN THE WORD "I'M".

FOR BABY APPARELS, NAMELY, SHIRTS, PANTS, DRESSES, SKIRTS, SHOES, SOCKS, PLASTIC AND CLOTH BIBS, BABY BODY SUITS, BABY BOTTOMS AND TOPS (U.S. CLS. 22 AND 39).

FIRST USE 11-9-2010; IN COMMERCE 11-9-2010.

4,017,275. PRATER, ARCHIE LEWIS, DBA HEART OF A LION, JONESBORO, GA. SN 77-691,708. FILED P.R. 3-16-2009; AM. S.R. 10-4-2010.



THE COLOR(S) BLACK, RED, AND WHITE IS/ARE CLAIMED AS A FEATURE OF THE MARK.

CLASS 25—(Continued).

THE MARK CONSISTS OF THE FOLLOWING: A DESIGN OF A ROARING LION WITH A BLACK FACE, RED WHISKERS, A BLACK AND RED MANE, A BLACK TONGUE INSIDE A RED MOUTH, WHITE TEETH AND BLACK AND WHITE EYES.

FOR CLOTHING AND APPAREL FOR MEN, WOMEN, YOUNG ADULTS, CHILDREN AND INFANTS, NAMELY, SHIRTS, EMBROIDERED SHIRTS, TEE SHIRTS, SHORTS, SPORT SHIRTS, SWEATSHIRTS, SWEATPANTS, SOCKS, VESTS, BELTS, LOUNGEWEAR, SLEEPWEAR, UNDERGARMENTS, UNDERPANTS, UNDERSHIRTS, BATHROBES, FOOTWEAR, UNDERWEAR, SWIMSUITS, BEACH COVER-UPS, WARM-UP SUITS, JACKETS, JERSEYS, TANK TOPS, SWEATERS, PANTS, JEANS, VESTS, SUITS, SPORT COATS, COATS, HEAD BANDS, OVERCOATS, RAIN COATS, TOP COATS, JACKETS, PARKAS, TIES, BOW TIES, NECKWEAR, VESTS, SCARVES, BANDANNAS, PAJAMAS, NIGHT SHIRTS, SUSPENDERS, GLOVES, HEADWEAR, HATS, BASEBALL CAPS, EMBROIDERED CAPS, KNITTED HATS, FOOTWEAR, SHOES, SLIPPERS, BOOTS, SANDALS, SNEAKERS, BODY SUITS, JUMPSUITS; CLOTHING FOR WOMEN AND YOUNG ADULTS, NAMELY, BRASSIERES, BUSTIERS, CAMISOLES, CHEMISES, CORSELETTES, CORSETS, FOUNDATION GARMENTS, DRESSING GOWNS, DUSTERS, GARTER BELTS, GIRDLES, HOUSECOATS, LINGERIE, NEGLIGEEES, NIGHT GOWNS, NIGHT SHIRTS, PAJAMAS, PEIGNOIRS, ROBES, TEDDIES, PANTIES, BLOUSES, DRESSES, SKIRTS, TOPS, SCARVES, SARONGS, HALTER TOPS, HOSIERY, JUMPERS, SHAWLS, STOLEES, SCARVES, SHRUGS, BOLEROS, AND WRAPS; INFANTWEAR (U.S. CLS. 22 AND 39).

FIRST USE 5-14-2010; IN COMMERCE 5-14-2010.

4,017,334. KRIZEK, DANE, WASHINGTON, WA. SN 85-127,750. FILED P.R. 9-13-2010; AM. S.R. 6-18-2011.

RAGGED HEM

THE MARK CONSISTS OF STANDARD CHARACTERS WITHOUT CLAIM TO ANY PARTICULAR FONT, STYLE, SIZE, OR COLOR.

FOR CLOTHING, NAMELY, T-SHIRTS, SHIRTS, SWEATERS, PANTS, JEANS, AND TIES (U.S. CLS. 22 AND 39).

FIRST USE 5-1-2011; IN COMMERCE 5-1-2011.

4,017,335. EASYFINE ASIA, LTD., PHILADELPHIA, PA. SN 85-127,879. FILED P.R. 9-13-2010; AM. S.R. 6-21-2011.

RETRO THREADS

THE MARK CONSISTS OF STANDARD CHARACTERS WITHOUT CLAIM TO ANY PARTICULAR FONT, STYLE, SIZE, OR COLOR.

CLASS 25—(Continued).

NO CLAIM IS MADE TO THE EXCLUSIVE RIGHT TO USE "THREADS", APART FROM THE MARK AS SHOWN.

FOR CLOTHING, NAMELY, MEN'S, WOMEN'S AND CHILDREN'S SPORTSWEAR, NAMELY, SHIRTS, TOPS AND SWEATERS; WOVEN AND KNIT SHIRTS AND SWEATERS FOR MEN, WOMEN AND CHILDREN (U.S. CLS. 22 AND 39).

FIRST USE 2-0-2011; IN COMMERCE 2-0-2011.

4,017,348. TANU U.S.A., INC., NEW YORK, NY. SN 85-143,716. FILED P.R. 10-2-2010; AM. S.R. 6-20-2011.

SUNWEAR USA

THE MARK CONSISTS OF STANDARD CHARACTERS WITHOUT CLAIM TO ANY PARTICULAR FONT, STYLE, SIZE, OR COLOR.

NO CLAIM IS MADE TO THE EXCLUSIVE RIGHT TO USE "SUNWEAR", APART FROM THE MARK AS SHOWN. FOR SHIRTS, T-SHIRTS, SWEATSHIRTS, SHORTS, JACKETS, GLOVES, PAJAMAS, SWIMSUITS, SKIRTS, DRESSES, TANK TOPS, PANTS, COATS, SWEATERS, SOCKS, AND ACCESSORIES, NAMELY, SCARVES, HEAD BANDS, AND POCKET KERCHIEFS (U.S. CLS. 22 AND 39).

FIRST USE 9-1-2010; IN COMMERCE 9-1-2010.

4,017,397. THE INDIANA SOCIETY FOR THE PREVENTION OF CRUELTY TO ANIMALS, AKA ISPCA, INDIANAPOLIS, IN. SN 85-264,536. FILED P.R. 3-11-2011; AM. S.R. 7-18-2011.

WELCOME TO INDY NOW GO HOME

THE MARK CONSISTS OF STANDARD CHARACTERS WITHOUT CLAIM TO ANY PARTICULAR FONT, STYLE, SIZE, OR COLOR.

FOR CLOTHING, NAMELY, PANTS, SHORTS, SWEATPANTS, OVERALLS, SHIRTS, TEE-SHIRTS, SWEATSHIRTS, BLOUSES, JACKETS, VESTS, COATS, RAINWEAR, SHOES, LINGERIE, SLEEPWEAR, LOUNGEWEAR, SWIMWEAR, GLOVES, SOCKS, HOSIERY, BELTS, SCARVES, HATS, TIES, SLIPPERS, APRONS (U.S. CLS. 22 AND 39).

FIRST USE 11-2-2010; IN COMMERCE 11-2-2010.

CLASS 25—(Continued).

4,017,398. NORMA JEAN HUBBARD, HUNTINGTON BEACH, CA. SN 85-264,670. FILED P.R. 3-11-2011; AM. S.R. 6-21-2011.

Get up Get up Get Healthy

THE MARK CONSISTS OF STANDARD CHARACTERS WITHOUT CLAIM TO ANY PARTICULAR FONT, STYLE, SIZE, OR COLOR.

FOR T-SHIRTS (U.S. CLS. 22 AND 39),
FIRST USE 3-4-2011; IN COMMERCE 3-4-2011.

4,017,424. GONZALES, DAVID PEREZ, DBA LATIN BOSS CLOTHING, MILWAUKEE, WI. SN 85-293,355. FILED 4-12-2011.



THE MARK CONSISTS OF EAGLE WITH FULL SPREAD WINGS HOVERING OVER CACTUS HOLDING SNAKE IN BOTH CLAWS FACING EACH OTHER WITH "LATIN BOSS" TEXT UNDER IT AND DESIGNED BARS ON BOTH SIDES OF THE "LATIN BOSS" TEXT REACHING UP TO THE EAGLES WINGS.

FOR ATHLETIC APPAREL, NAMELY, SHIRTS, PANTS, JACKETS, FOOTWEAR, HATS AND CAPS, ATHLETIC UNIFORMS (U.S. CLS. 22 AND 39).
FIRST USE 1-1-2009; IN COMMERCE 9-1-2010.

CLASS 26—FANCY GOODS

4,017,292. HOBBY LOBBY STORES, INC., OKLAHOMA CITY, OK. SN 77-949,467. FILED 3-3-2010.

FANCY FEATHERS

THE MARK CONSISTS OF STANDARD CHARACTERS WITHOUT CLAIM TO ANY PARTICULAR FONT, STYLE, SIZE, OR COLOR.

NO CLAIM IS MADE TO THE EXCLUSIVE RIGHT TO USE "FEATHERS", APART FROM THE MARK AS SHOWN.
FOR FEATHERS FOR ORNAMENTATION (U.S. CLS. 37, 39, 40, 42 AND 50).
FIRST USE 6-1-1999; IN COMMERCE 6-1-1999.

CLASS 28—TOYS AND SPORTING GOODS

4,017,290. LEVERAGE LANDING NET, LLC, OXFORD, MI. SN 77-933,156. FILED P.R. 2-11-2010; AM. S.R. 11-19-2010.

LEVERAGE LANDING NET

THE MARK CONSISTS OF STANDARD CHARACTERS WITHOUT CLAIM TO ANY PARTICULAR FONT, STYLE, SIZE, OR COLOR.

NO CLAIM IS MADE TO THE EXCLUSIVE RIGHT TO USE "LANDING NET", APART FROM THE MARK AS SHOWN.

FOR SPORTING GOODS, NAMELY, HANDHELD FISHING NETS AND LANDING NETS FOR FISHERMAN (U.S. CLS. 22, 23, 38 AND 50).

FIRST USE 11-1-2008; IN COMMERCE 2-1-2009.

4,017,306. MAGIC BY RANDY, INC., GLENVIEW, IL. SN 85-092,936. FILED P.R. 7-26-2010; AM. S.R. 5-11-2011.

THE MAGIC GAME CUBE

THE MARK CONSISTS OF STANDARD CHARACTERS WITHOUT CLAIM TO ANY PARTICULAR FONT, STYLE, SIZE, OR COLOR.

FOR MAGIC TRICKS; PARTY GAMES (U.S. CLS. 22, 23, 38 AND 50).

FIRST USE 9-0-2010; IN COMMERCE 9-0-2010.

4,017,361. GENERAL FOAM PLASTICS CORPORATION, NORFOLK, VA. SN 85-168,052. FILED P.R. 11-3-2010; AM. S.R. 6-23-2011.

Easy to Light

THE MARK CONSISTS OF STANDARD CHARACTERS WITHOUT CLAIM TO ANY PARTICULAR FONT, STYLE, SIZE, OR COLOR.

FOR ARTIFICIAL CHRISTMAS TREES (U.S. CLS. 22, 23, 38 AND 50).

FIRST USE 11-0-2010; IN COMMERCE 2-0-2011.

CLASS 30—STAPLE FOODS

CLASS 30—(Continued).

4,017,288. LA BRISA ICE CREAM COMPANY, HOUSTON, TX. SN 77-904,418. FILED P.R. 1-4-2010; AM. S.R. 6-1-2011.

DIP'D

THE MARK CONSISTS OF STANDARD CHARACTERS WITHOUT CLAIM TO ANY PARTICULAR FONT, STYLE, SIZE, OR COLOR.

FOR ICE CREAM, FROZEN CONFECTIONS, ICE MILK BARS (U.S. CL. 46).

FIRST USE 2-8-2005; IN COMMERCE 4-10-2005.

4,017,328. AB MAURI FOOD INC., CORDOVA, TN. SN 85-125,688. FILED P.R. 9-9-2010; AM. S.R. 6-20-2011.

BAKER'S BEST

THE MARK CONSISTS OF STANDARD CHARACTERS WITHOUT CLAIM TO ANY PARTICULAR FONT, STYLE, SIZE, OR COLOR.

OWNER OF U.S. REG. NO. 3,257,252.
FOR CORN SYRUPS, BAKERY SYRUPS, FLOUR, SUGAR, VINEGAR, MOLASSES, BAKING POWDER, AND BAKING SODA (U.S. CL. 46).

FIRST USE 12-20-2010; IN COMMERCE 12-20-2010.

4,017,371. STEAK N SHAKE, LLC, INDIANAPOLIS, IN. SN 85-178,247. FILED P.R. 11-16-2010; AM. S.R. 6-3-2011.

THE ORIGINAL DOUBLE 'N CHEESE

THE MARK CONSISTS OF STANDARD CHARACTERS WITHOUT CLAIM TO ANY PARTICULAR FONT, STYLE, SIZE, OR COLOR.

OWNER OF U.S. REG. NO. 3,589,618.

FOR SANDWICHES (U.S. CL. 46).

FIRST USE 11-30-2009; IN COMMERCE 11-30-2009.

CLASS 32—LIGHT BEVERAGES

CLASS 32—(Continued).

4,017,301. KRUEGER BREWING COMPANY, LOVELAND, CO. SN 85-023,774. FILED P.R. 4-27-2010; AM. S.R. 1-28-2011.

KRUEGER BREWING COMPANY

THE MARK CONSISTS OF STANDARD CHARACTERS WITHOUT CLAIM TO ANY PARTICULAR FONT, STYLE, SIZE, OR COLOR.

NO CLAIM IS MADE TO THE EXCLUSIVE RIGHT TO USE "BREWING COMPANY", APART FROM THE MARK AS SHOWN.

FOR NON-ALCOHOLIC BEVERAGES, NAMELY, ROOT BEERS AND NON-ALCOHOLIC BEERS (U.S. CLS. 45, 46 AND 48).

FIRST USE 3-1-2010; IN COMMERCE 1-1-2011.

CLASS 33—WINES AND SPIRITS

4,017,342. AZAR DISTILLING, LLC, SAN ANTONIO, TX. SN 85-137,946. FILED P.R. 9-24-2010; AM. S.R. 6-21-2011.

Made From American Wheat

THE MARK CONSISTS OF STANDARD CHARACTERS WITHOUT CLAIM TO ANY PARTICULAR FONT, STYLE, SIZE, OR COLOR.

FOR DISTILLED SPIRITS (U.S. CLS. 47 AND 49).

FIRST USE 3-24-2011; IN COMMERCE 3-24-2011.

4,017,423. VOLI SPIRITS, LLC, WEST HOLLYWOOD, CA. SN 85-291,911. FILED P.R. 4-11-2011; AM. S.R. 6-21-2011.

THE WORLD'S FIRST LINE OF LOW CALORIE VODKAS

THE MARK CONSISTS OF STANDARD CHARACTERS WITHOUT CLAIM TO ANY PARTICULAR FONT, STYLE, SIZE, OR COLOR.

NO CLAIM IS MADE TO THE EXCLUSIVE RIGHT TO USE "VODKAS", APART FROM THE MARK AS SHOWN.

FOR VODKAS (U.S. CLS. 47 AND 49).

FIRST USE 2-28-2011; IN COMMERCE 2-28-2011.

CLASS 34—SMOKERS' ARTICLES

CLASS 34—(Continued).

4,017,317. VIVACITYLIFE, LLC, SCARBOROUGH, ME. SN 85-114,012. FILED P.R. 8-23-2010; AM. S.R. 6-2-2011.

AMERICAN BLUE TIP

THE MARK CONSISTS OF STANDARD CHARACTERS WITHOUT CLAIM TO ANY PARTICULAR FONT, STYLE, SIZE, OR COLOR.

NO CLAIM IS MADE TO THE EXCLUSIVE RIGHT TO USE "AMERICAN", APART FROM THE MARK AS SHOWN. FOR ELECTRONIC CIGARETTES FOR USE AS AN ALTERNATIVE TO TRADITIONAL CIGARETTES; SMOKELESS CIGARETTE VAPORIZER PIPE (U.S. CLS. 2, 8, 9 AND 17).

FIRST USE 4-24-2010; IN COMMERCE 4-24-2010.

SERVICE MARKS**CLASS 35—ADVERTISING AND BUSINESS**

4,017,273. FLEXPATHS, LLC, HILLSDALE, NJ. SN 77-482,228. FILED P.R. 5-23-2008; AM. S.R. 7-18-2011.

FLEX MANAGEMENT

THE MARK CONSISTS OF STANDARD CHARACTERS WITHOUT CLAIM TO ANY PARTICULAR FONT, STYLE, SIZE, OR COLOR.

FOR PROVIDING PERSONNEL PLACEMENT SERVICES VIA AN ONLINE WEBSITE, NAMELY, JOB PLACEMENT COUNSELING AND LINKS TO OTHER RECRUITING WEBSITES AND PROVIDING INFORMATION FOR FLEXIBLE WORK ARRANGEMENTS (U.S. CLS. 100, 101 AND 102).

FIRST USE 1-31-2008; IN COMMERCE 1-31-2008.

4,017,282. AMERICAN INTERNATIONAL RADIO, INC., ROLLING MEADOWS, IL. SN 77-819,864. FILED P.R. 9-3-2009; AM. S.R. 7-15-2011.

**AMERICAN INTERNATIONAL
RADIO**

THE MARK CONSISTS OF STANDARD CHARACTERS WITHOUT CLAIM TO ANY PARTICULAR FONT, STYLE, SIZE, OR COLOR.

CLASS 35—(Continued).

NO CLAIM IS MADE TO THE EXCLUSIVE RIGHT TO USE "RADIO", APART FROM THE MARK AS SHOWN.

FOR DISTRIBUTORSHIP SERVICES IN THE FIELD OF PROFESSIONAL RADIO COMMUNICATION PRODUCTS, RADIO SYSTEM INTEGRATORS, AND WIRELESS BROADBAND SYSTEMS (U.S. CLS. 100, 101 AND 102).

FIRST USE 12-1-1990; IN COMMERCE 12-1-1990.

4,017,289. GLOBAL RANCH, LLC, SAN DIEGO, CA. SN 77-911,807. FILED P.R. 1-14-2010; AM. S.R. 7-11-2011.

GLOBAL RANCH

THE MARK CONSISTS OF STANDARD CHARACTERS WITHOUT CLAIM TO ANY PARTICULAR FONT, STYLE, SIZE, OR COLOR.

FOR WHOLESALE FOOD DISTRIBUTORSHIPS (U.S. CLS. 100, 101 AND 102).

FIRST USE 5-1-2009; IN COMMERCE 5-1-2009.

4,017,293. SHANAHAN, KEITH E., NORTH PALM BEACH, FL. SN 77-965,732. FILED P.R. 3-23-2010; AM. S.R. 2-23-2011.

THE MOVIE NETWORK.COM

THE MARK CONSISTS OF STANDARD CHARACTERS WITHOUT CLAIM TO ANY PARTICULAR FONT, STYLE, SIZE, OR COLOR.

FOR ELECTRONIC WEBSITE MARKETING SERVICES, NAMELY, CREATING ON-LINE PROMOTIONS FOR OTHERS; PROMOTING THE GOODS AND SERVICES OF OTHERS BY PLACING ADVERTISEMENT AND PROMOTIONAL DISPLAYS IN AN ELECTRONIC SITE ACCESS THROUGH COMPUTER NETWORK; PROMOTING THE GOODS AND SERVICES OF OTHERS BY PLACING HYPertext LINKS TO ELECTRONIC SITES OF OTHERS ACCESSED THROUGH COMPUTER NETWORKS, RETAIL MAIL ORDER SERVICES FEATURING MOVIES AND A VARIETY OF GOODS RELATING TO MOVIES AND THE MOVIE INDUSTRY, NAMELY, PRERECORDED VIDEO TAPES, CD-ROM, LASER DISCS, DVDS, COMPACT DISCS, MAGAZINE AND NEWSLETTER SUBSCRIPTIONS FEATURING AND/OR PERTAINING TO MOTION PICTURES, TELEVISION PROGRAMS, FEATURE FILMS, DOCUMENTARIES, ANIMATED FILMS, TELEVISION MOVIES, ANIMATED TELEVISION PROGRAMS, MUSIC, SHORT SUBJECTS; MAIL ORDER PRODUCT FULFILLMENT SERVICES FOR THIRD PARTIES IN THE FIELD OF MOVIES, NAMELY, PRERECORDED VIDEO AND AUDIO TAPES, LASER DISCS, COMPACT DISCS, BLANK VIDEO AND AUDIO TAPES, MAGAZINE AND NEWSLETTER SUBSCRIPTIONS; RETAIL MAIL ORDER SERVICES FEATURING ELECTRONIC, VIDEO AND COMPUTER GAMES AND MAGAZINES AND NEWSLETTERS CONCERNING THE SAME; FACILITATING INTERACTIVE ONLINE REVIEWS FOR MOVIES, ELECTRONIC, VIDEO AND COMPUTER GAMES (U.S. CLS. 100, 101 AND 102).

FIRST USE 2-23-2011; IN COMMERCE 2-23-2011.

CLASS 35—(Continued).

4,017,311. ADAMS, ADAMS & ADAMS, LLC, HUNTINGTON BEACH, CA. SN 85-107,010. FILED P.R. 8-13-2010; AM. S.R. 6-9-2011.

SHOROOM

NO CLAIM IS MADE TO THE EXCLUSIVE RIGHT TO USE "SHOWROOM", APART FROM THE MARK AS SHOWN.

THE MARK CONSISTS OF THE MARK "SHOROOM" WITH A BAR OVER THE FIRST LETTER "O".

FOR ONLINE RETAIL STORE SERVICES FEATURING MEN'S AND WOMEN'S CLOTHING AND ACCESSORIES FOR USE THEREWITH (U.S. CLS. 100, 101 AND 102).

FIRST USE 7-0-2010; IN COMMERCE 7-0-2010.

4,017,320. INSTITUTE OF INTELLECTUAL PROPERTY AND SOCIAL JUSTICE, INC., AKA IIP SJ, INC., COLUMBIA, MD. SN 85-116,097. FILED P.R. 8-26-2010; AM. S.R. 7-12-2011.

INSTITUTE OF INTELLECTUAL PROPERTY AND SOCIAL JUSTICE

THE MARK CONSISTS OF STANDARD CHARACTERS WITHOUT CLAIM TO ANY PARTICULAR FONT, STYLE, SIZE, OR COLOR.

NO CLAIM IS MADE TO THE EXCLUSIVE RIGHT TO USE "INSTITUTE", APART FROM THE MARK AS SHOWN.

FOR PROFESSIONAL NETWORKING SERVICES, NAMELY, CONDUCTING PROFESSIONAL NETWORKING EVENTS IN THE FIELDS OF EDUCATION IN INTELLECTUAL PROPERTY, LAW, AND SOCIAL JUSTICE (U.S. CLS. 100, 101 AND 102).

FIRST USE 10-2-2002; IN COMMERCE 10-2-2002.

4,017,322. H&O DISTRIBUTION, INC., AKA OSBORNE TRUCKING COMPANY, FAIRFIELD, OH. SN 85-119,974. FILED P.R. 8-31-2010; AM. S.R. 6-16-2011.

The Osborne Logistics Group

THE MARK CONSISTS OF STANDARD CHARACTERS WITHOUT CLAIM TO ANY PARTICULAR FONT, STYLE, SIZE, OR COLOR.

CLASS 35—(Continued).

NO CLAIM IS MADE TO THE EXCLUSIVE RIGHT TO USE "LOGISTICS GROUP", APART FROM THE MARK AS SHOWN.

FOR TRANSPORTATION LOGISTICS SERVICES, NAMELY, PLANNING AND SCHEDULING SHIPMENTS FOR USERS OF TRANSPORTATION SERVICES (U.S. CLS. 100, 101 AND 102).

FIRST USE 8-28-2009; IN COMMERCE 8-28-2009.

4,017,326. SKIN HOLEZ, COPPEROPOLIS, CA. SN 85-124,192. FILED P.R. 9-7-2010; AM. S.R. 7-14-2011.

Skin Holez

THE MARK CONSISTS OF THE TEXT "SKIN HOLEZ" WRITTEN IN LABRIT FONT WITH CONES AND BEAD INCORPORATED IN LETTERING.

FOR MOBILE RETAIL STORE SERVICES FEATURING BODY JEWELRY; ON-LINE RETAIL STORE SERVICES FEATURING BODY JEWELRY (U.S. CLS. 100, 101 AND 102).

FIRST USE 8-17-2010; IN COMMERCE 10-2-2010.

4,017,337. OWENS, DANIEL, FREDERICK, NASHVILLE, TN. SN 85-130,225. FILED P.R. 9-15-2010; AM. S.R. 6-19-2011.

America's Online Dealership

THE MARK CONSISTS OF STANDARD CHARACTERS WITHOUT CLAIM TO ANY PARTICULAR FONT, STYLE, SIZE, OR COLOR.

NO CLAIM IS MADE TO THE EXCLUSIVE RIGHT TO USE "ONLINE DEALERSHIP", APART FROM THE MARK AS SHOWN.

FOR AUTOMOBILE DEALERSHIPS (U.S. CLS. 100, 101 AND 102).

FIRST USE 8-1-2010; IN COMMERCE 9-1-2010.

CLASS 35—(Continued).

4,017,338. DDS SOLUTIONS LLC, MORGANTOWN, WV. SN 85-133,915. FILED P.R. 9-20-2010; AM. S.R. 6-29-2011.



THE MARK CONSISTS OF STYLIZED UPPERCASE LETTERS "D", "D", AND "S" CONNECTED TOGETHER IN THAT SEQUENCE, WITH THE RIGHT-HAND PORTION OF THE FIRST LETTER "D" SUPERIMPOSED WITH THE LEFT-HAND PORTION OF THE SECOND LETTER "D", AND THE RIGHT-HAND PORTION OF THE SECOND LETTER "D" SUPERIMPOSED WITH THE THIRD LETTER "S".

FOR PROVIDING ADVERTISING, MARKETING AND PROMOTIONAL SERVICES FOR DENTAL PRACTICES (U.S. CLS. 100, 101 AND 102).

FIRST USE 3-1-2011; IN COMMERCE 3-1-2011.

4,017,349. FILANTHROPISTS.COM, INC., OAKLAND, NJ. SN 85-145,408. FILED P.R. 10-5-2010; AM. S.R. 6-27-2011.

Filanthropists.com

THE MARK CONSISTS OF STANDARD CHARACTERS WITHOUT CLAIM TO ANY PARTICULAR FONT, STYLE, SIZE, OR COLOR.

FOR ONLINE RETAIL STORE SERVICES FEATURING A WIDE VARIETY OF CAUSE-RELATED CONSUMER GOODS OF OTHERS WHEREIN A PERCENTAGE OF SALES PROCEEDS ARE DONATED TO CHARITY; ONLINE PROMOTIONAL SERVICES IN THE NATURE OF PROMOTING THE CHARITABLE FUNDRAISING EFFORTS OF CHARITIES AND PRODUCT VENDORS (U.S. CLS. 100, 101 AND 102).

FIRST USE 11-1-2009; IN COMMERCE 6-1-2010.

CLASS 35—(Continued).

4,017,353. CONSUMER BENEFIT SERVICES, INC., DBA CBSI, NAPERVILLE, IL. SN 85-151,749. FILED P.R. 10-13-2010; AM. S.R. 7-19-2011.

PERKS POINTS MALL

THE MARK CONSISTS OF STANDARD CHARACTERS WITHOUT CLAIM TO ANY PARTICULAR FONT, STYLE, SIZE, OR COLOR.

FOR PROMOTING THE GOODS AND SERVICES OF OTHERS BY MEANS OF A PREFERRED CUSTOMER PROGRAM FEATURING A LOYALTY PROGRAM THAT OFFERS REWARD CARDS, POINTS, AND DISCOUNTS ON PRODUCTS OFFERED BY COMMERCIAL PARTNERS (U.S. CLS. 100, 101 AND 102).

FIRST USE 10-1-2010; IN COMMERCE 10-1-2010.

4,017,354. GREEN TEXTBOOKS, LLC, DBA GREEN TEXTBOOKS, SANDY, UT. SN 85-152,743. FILED P.R. 10-14-2010; AM. S.R. 5-31-2011.

Green Textbooks

THE MARK CONSISTS OF STANDARD CHARACTERS WITHOUT CLAIM TO ANY PARTICULAR FONT, STYLE, SIZE, OR COLOR.

NO CLAIM IS MADE TO THE EXCLUSIVE RIGHT TO USE "TEXTBOOKS", APART FROM THE MARK AS SHOWN.

FOR PROVIDING A BUY-BACK AND TRADE-IN PROGRAM FOR USED TEXTBOOKS OF OTHERS (U.S. CLS. 100, 101 AND 102).

FIRST USE 3-9-2008; IN COMMERCE 3-9-2008.

4,017,359. INTERNATIONAL DATA GROUP, INC., FRAMINGHAM, MA. SN 85-161,025. FILED P.R. 10-26-2010; AM. S.R. 7-13-2011.

**THE GLOBAL STATE OF
INFORMATION SECURITY**

THE MARK CONSISTS OF STANDARD CHARACTERS WITHOUT CLAIM TO ANY PARTICULAR FONT, STYLE, SIZE, OR COLOR.

OWNER OF U.S. REG. NO. 2,936,094.
FOR CONDUCTING BUSINESS RESEARCH AND SURVEYS; PROVIDING STATISTICAL INFORMATION (U.S. CLS. 100, 101 AND 102).

FIRST USE 9-30-2003; IN COMMERCE 9-30-2003.

CLASS 35—(Continued).

4,017,363. APOLLOBRAVO INC., ALEXANDRIA, VA. SN 85-171,083. FILED P.R. 11-8-2010; AM. S.R. 6-4-2011.

SOCIAL PROMOTER

THE MARK CONSISTS OF STANDARD CHARACTERS WITHOUT CLAIM TO ANY PARTICULAR FONT, STYLE, SIZE, OR COLOR.

NO CLAIM IS MADE TO THE EXCLUSIVE RIGHT TO USE "PROMOTER", APART FROM THE MARK AS SHOWN.

FOR ADVERTISING SERVICES, NAMELY, ADVERTISING THE GOODS AND SERVICES OF OTHERS BY MEANS OF PROVIDING COMMERCIAL INFORMATION AND ADVICE FOR CONSUMERS VIA SOCIAL MEDIA SITES, MOBILE WEBSITES, AND SMS TEXT MESSAGING; ADVERTISING SERVICES, NAMELY, PROVIDING AN INTERNET WEBSITE PORTAL FOR THE MANAGEMENT AND DISTRIBUTION OF THE PROMOTIONAL INFORMATION OF OTHERS (U.S. CLS. 100, 101 AND 102).

FIRST USE 8-1-2010; IN COMMERCE 10-6-2010.

4,017,370. JUAREZ, ERNESTO, OJAI, CA. SN 85-174,900. FILED P.R. 11-11-2010; AM. S.R. 7-12-2011.

INKSTOCK.COM

THE MARK CONSISTS OF STANDARD CHARACTERS WITHOUT CLAIM TO ANY PARTICULAR FONT, STYLE, SIZE, OR COLOR.

FOR ON-LINE RETAIL STORE SERVICES FEATURING PRINTER-RELATED PRODUCTS AND SUPPLIES (U.S. CLS. 100, 101 AND 102).

FIRST USE 11-2-2010; IN COMMERCE 2-18-2011.

4,017,378. JIMMYS WOOL, LLC, DBA JIMMY BEANS WOOL, RENO, NV. SN 85-201,424. FILED P.R. 12-19-2010; AM. S.R. 6-10-2011.

Knit Red

THE MARK CONSISTS OF STANDARD CHARACTERS WITHOUT CLAIM TO ANY PARTICULAR FONT, STYLE, SIZE, OR COLOR.

CLASS 35—(Continued).

NO CLAIM IS MADE TO THE EXCLUSIVE RIGHT TO USE "KNIT", APART FROM THE MARK AS SHOWN.

FOR RETAIL STORE AND ON-LINE RETAIL STORE SERVICES FEATURING KNITTING AND CROCHETING SUPPLIES, YARNS, PATTERNS, NEEDLES, KNITTING ACCESSORIES, KNITTING KITS, BOOKS, AND MAGAZINES (U.S. CLS. 100, 101 AND 102).

FIRST USE 1-15-2008; IN COMMERCE 1-15-2008.

4,017,380. GREEN HILL HEALTHCARE COMMUNICATIONS, LLC, MONROE TOWNSHIP, NJ. SN 85-213,698. FILED P.R. 1-10-2011; AM. S.R. 7-7-2011.

THE ONCOLOGY NURSE-APN/PA

THE MARK CONSISTS OF STANDARD CHARACTERS WITHOUT CLAIM TO ANY PARTICULAR FONT, STYLE, SIZE, OR COLOR.

OWNER OF U.S. REG. NOS. 3,621,208 AND 3,624,945. FOR ADVERTISING SERVICES, NAMELY, PROVIDING ADVERTISING SPACE IN PRINT AND ELECTRONIC JOURNALS, MAGAZINES, NEWSLETTERS, FEATURE REPORTS, PRINT AND ELECTRONIC SUPPLEMENTS AND WEB SITES THAT CONCERN INFORMATION IN THE FIELDS OF HEMATOLOGY, ONCOLOGY AND NURSING (U.S. CLS. 100, 101 AND 102).

FIRST USE 6-1-2010; IN COMMERCE 6-1-2010.

4,017,386. LIM, THOMAS, OAKLAND, CA. SN 85-236,264. FILED P.R. 2-8-2011; AM. S.R. 6-21-2011.

CHINESEINSURANCEAGENTS.COM

THE MARK CONSISTS OF STANDARD CHARACTERS WITHOUT CLAIM TO ANY PARTICULAR FONT, STYLE, SIZE, OR COLOR.

FOR PROVIDING A WEB SITE THAT LISTS INSURANCE AGENTS AND BROKERS FLUENT IN CHINESE; PROMOTION OF FINANCIAL AND INSURANCE SERVICES, ON BEHALF OF THIRD PARTIES (U.S. CLS. 100, 101 AND 102).

FIRST USE 8-8-2010; IN COMMERCE 8-8-2010.

CLASS 35—(Continued).

4,017,390. BOND JEWELERS, INC., PHILADELPHIA, PA. SN 85-247,518. FILED P.R. 2-21-2011; AM. S.R. 7-15-2011.

UNCLAIMED LAYAWAYS

THE MARK CONSISTS OF STANDARD CHARACTERS WITHOUT CLAIM TO ANY PARTICULAR FONT, STYLE, SIZE, OR COLOR.

OWNER OF U.S. REG. NOS. 2,859,899 AND 3,129,652. NO CLAIM IS MADE TO THE EXCLUSIVE RIGHT TO USE "LAYAWAYS", APART FROM THE MARK AS SHOWN.

FOR ON-LINE RETAIL STORE SERVICES FEATURING RETAIL JEWELRY; RETAIL JEWELRY STORES (U.S. CLS. 100, 101 AND 102).

FIRST USE 3-1-2010; IN COMMERCE 3-1-2010.

CLASS 35—(Continued).

4,017,406. FAIRWAY GROUP ACQUISITION COMPANY, NEW YORK, NY. SN 85-274,215. FILED 3-23-2011.

**THE WORLD'S GREATEST WINES
& SPIRITS STORE**

THE MARK CONSISTS OF STANDARD CHARACTERS WITHOUT CLAIM TO ANY PARTICULAR FONT, STYLE, SIZE, OR COLOR.

NO CLAIM IS MADE TO THE EXCLUSIVE RIGHT TO USE "WINES & SPIRITS STORE", APART FROM THE MARK AS SHOWN.

FOR RETAIL AND ONLINE RETAIL STORE SERVICES FEATURING WINES AND SPIRITS (U.S. CLS. 100, 101 AND 102).

FIRST USE 12-15-2010; IN COMMERCE 12-15-2010.

4,017,401. GREEN, WILLIAM J., DBA LURETRADER, OSAGE BEACH, MO. SN 85-271,444. FILED P.R. 3-19-2011; AM. S.R. 6-17-2011.

Luretrader

THE MARK CONSISTS OF STANDARD CHARACTERS WITHOUT CLAIM TO ANY PARTICULAR FONT, STYLE, SIZE, OR COLOR.

FOR RETAIL STORE AND ON-LINE RETAIL STORE SERVICES FEATURING FISHING TACKLE (U.S. CLS. 100, 101 AND 102).

FIRST USE 1-1-2011; IN COMMERCE 1-21-2011.

4,017,407. WORLD ASSOCIATION OF SLEEP MEDICINE FOUNDATION, ROCHESTER, MN. SN 85-274,932. FILED 3-23-2011.

world sleep day

THE MARK CONSISTS OF STANDARD CHARACTERS WITHOUT CLAIM TO ANY PARTICULAR FONT, STYLE, SIZE, OR COLOR.

FOR PUBLIC ADVOCACY TO PROMOTE AWARENESS OF SLEEP HEALTH (U.S. CLS. 100, 101 AND 102).

FIRST USE 11-1-2007; IN COMMERCE 11-1-2007.

4,017,405. NATIONAL ASSOCIATION OF CONVENIENCE STORES, ALEXANDRIA, VA. SN 85-273,442. FILED P.R. 3-22-2011; AM. S.R. 6-24-2011.

**THE ASSOCIATION FOR
CONVENIENCE & FUEL
RETAILING**

THE MARK CONSISTS OF STANDARD CHARACTERS WITHOUT CLAIM TO ANY PARTICULAR FONT, STYLE, SIZE, OR COLOR.

OWNER OF U.S. REG. NOS. 1,719,073 AND 3,188,372. NO CLAIM IS MADE TO THE EXCLUSIVE RIGHT TO USE "ASSOCIATION", APART FROM THE MARK AS SHOWN.

FOR ASSOCIATION SERVICES, NAMELY, PROMOTING THE INTERESTS OF CONVENIENCE STORE AND FUEL MARKETING COMPANIES (U.S. CLS. 100, 101 AND 102).

FIRST USE 11-0-2010; IN COMMERCE 11-0-2010.

4,017,409. EVENT WHOLESALE SUPPLIES, INC., SYLMAR, CA. SN 85-276,915. FILED P.R. 3-25-2011; AM. S.R. 6-23-2011.

EVENT WHOLESALE SUPPLY

THE MARK CONSISTS OF STANDARD CHARACTERS WITHOUT CLAIM TO ANY PARTICULAR FONT, STYLE, SIZE, OR COLOR.

NO CLAIM IS MADE TO THE EXCLUSIVE RIGHT TO USE "WHOLESALE SUPPLY", APART FROM THE MARK AS SHOWN.

FOR WHOLESALE AND RETAIL STORE SERVICES AND ON-LINE RETAIL AND WHOLESALE STORE SERVICES FEATURING PARTY AND EVENT PRODUCTS AND SUPPLIES (U.S. CLS. 100, 101 AND 102).

FIRST USE 7-25-2009; IN COMMERCE 7-25-2009.

CLASS 35—(Continued).

4,017,411. CDF HOLDINGS LLC, SCOTTSDALE, AZ. SN 85-279,605. FILED 3-29-2011.

**Comprehensive Physician
Finance**

THE MARK CONSISTS OF STANDARD CHARACTERS WITHOUT CLAIM TO ANY PARTICULAR FONT, STYLE, SIZE, OR COLOR.

NO CLAIM IS MADE TO THE EXCLUSIVE RIGHT TO USE "FINANCE", APART FROM THE MARK AS SHOWN.

FOR ELECTIVE CARE DEPARTMENT BILLING; REVENUE CYCLE MANAGEMENT SERVICES PROVIDED TO HEALTHCARE PRACTICE GROUPS AND HOSPITALS SPECIALIZING IN ELECTIVE CARE PROCEDURES, NAMELY, ADMINISTRATION, BILLING AND RECONCILIATION OF ACCOUNTS ON BEHALF OF OTHERS; TRACKING AND MONITORING INSURANCE COMPLIANCE FOR HEALTHCARE PRACTICE GROUPS AND HOSPITALS SPECIALIZING IN ELECTIVE CARE PROCEDURES (U.S. CLS. 100, 101 AND 102).

FIRST USE 3-25-2011; IN COMMERCE 3-25-2011.

CLASS 35—(Continued).

4,017,413. CDF HOLDINGS LLC, SCOTTSDALE, AZ. SN 85-279,793. FILED 3-29-2011.

**Comprehensive Medical
Finance**

THE MARK CONSISTS OF STANDARD CHARACTERS WITHOUT CLAIM TO ANY PARTICULAR FONT, STYLE, SIZE, OR COLOR.

NO CLAIM IS MADE TO THE EXCLUSIVE RIGHT TO USE "FINANCE", APART FROM THE MARK AS SHOWN.

FOR ELECTIVE CARE DEPARTMENT BILLING; REVENUE CYCLE MANAGEMENT SERVICES PROVIDED TO HEALTHCARE PRACTICE GROUPS AND HOSPITALS SPECIALIZING IN ELECTIVE CARE PROCEDURES, NAMELY, ADMINISTRATION, BILLING AND RECONCILIATION OF ACCOUNTS ON BEHALF OF OTHERS; TRACKING AND MONITORING INSURANCE COMPLIANCE FOR HEALTHCARE PRACTICE GROUPS AND HOSPITALS SPECIALIZING IN ELECTIVE CARE PROCEDURES (U.S. CLS. 100, 101 AND 102).

FIRST USE 3-25-2011; IN COMMERCE 3-25-2011.

4,017,412. CDF HOLDINGS LLC, SCOTTSDALE, AZ. SN 85-279,702. FILED 3-29-2011.

**Comprehensive Dental
Finance**

THE MARK CONSISTS OF STANDARD CHARACTERS WITHOUT CLAIM TO ANY PARTICULAR FONT, STYLE, SIZE, OR COLOR.

NO CLAIM IS MADE TO THE EXCLUSIVE RIGHT TO USE "FINANCE", APART FROM THE MARK AS SHOWN.

FOR ELECTIVE CARE DEPARTMENT BILLING; REVENUE CYCLE MANAGEMENT SERVICES PROVIDED TO HEALTHCARE PRACTICE GROUPS AND HOSPITALS SPECIALIZING IN ELECTIVE CARE PROCEDURES, NAMELY, ADMINISTRATION, BILLING AND RECONCILIATION OF ACCOUNTS ON BEHALF OF OTHERS; TRACKING AND MONITORING INSURANCE COMPLIANCE FOR HEALTHCARE PRACTICE GROUPS AND HOSPITALS SPECIALIZING IN ELECTIVE CARE PROCEDURES (U.S. CLS. 100, 101 AND 102).

FIRST USE 3-25-2011; IN COMMERCE 3-25-2011.

4,017,414. CDF HOLDINGS LLC, SCOTTSDALE, AZ. SN 85-279,834. FILED 3-29-2011.

Comprehensive Finance

THE MARK CONSISTS OF STANDARD CHARACTERS WITHOUT CLAIM TO ANY PARTICULAR FONT, STYLE, SIZE, OR COLOR.

NO CLAIM IS MADE TO THE EXCLUSIVE RIGHT TO USE "FINANCE", APART FROM THE MARK AS SHOWN.

FOR ELECTIVE CARE DEPARTMENT BILLING; REVENUE CYCLE MANAGEMENT SERVICES PROVIDED TO HEALTHCARE PRACTICE GROUPS AND HOSPITALS SPECIALIZING IN ELECTIVE CARE PROCEDURES, NAMELY, ADMINISTRATION, BILLING AND RECONCILIATION OF ACCOUNTS ON BEHALF OF OTHERS; TRACKING AND MONITORING INSURANCE COMPLIANCE FOR HEALTHCARE PRACTICE GROUPS AND HOSPITALS SPECIALIZING IN ELECTIVE CARE PROCEDURES (U.S. CLS. 100, 101 AND 102).

FIRST USE 3-25-2011; IN COMMERCE 3-25-2011.

CLASS 35—(Continued).

4,017,427. SILLS, JERRY, VIRGINIA BEACH, VA. SN 85-333,090. FILED P.R. 5-28-2011; AM. S.R. 7-7-2011.

Tactical Distributors

THE MARK CONSISTS OF STANDARD CHARACTERS WITHOUT CLAIM TO ANY PARTICULAR FONT, STYLE, SIZE, OR COLOR.

NO CLAIM IS MADE TO THE EXCLUSIVE RIGHT TO USE "DISTRIBUTORS", APART FROM THE MARK AS SHOWN.

FOR RETAIL STORE AND ON-LINE RETAIL STORE SERVICES FEATURING TACTICAL, FIRST RESPONDER, AND LIFE SAVING EQUIPMENT (U.S. CLS. 100, 101 AND 102).

FIRST USE 6-22-2006; IN COMMERCE 6-22-2006.

4,017,428. FESTFARE, INC, LAS VEGAS, CA. SN 85-333,468. FILED P.R. 5-30-2011; AM. S.R. 7-14-2011.

1800DEPOPRO.COM

THE MARK CONSISTS OF STANDARD CHARACTERS WITHOUT CLAIM TO ANY PARTICULAR FONT, STYLE, SIZE, OR COLOR.

FOR STENOGRAPHIC TRANSCRIPTION (U.S. CLS. 100, 101 AND 102).

FIRST USE 1-1-2000; IN COMMERCE 1-1-2000.

CLASS 36—INSURANCE AND FINANCIAL

4,017,300. ZIONS BANCORPORATION, SALT LAKE CITY, UT. SN 85-017,063. FILED P.R. 4-19-2010; AM. S.R. 11-24-2010.

COURTESY APPROVAL

THE MARK CONSISTS OF STANDARD CHARACTERS WITHOUT CLAIM TO ANY PARTICULAR FONT, STYLE, SIZE, OR COLOR.

FOR FINANCIAL OVERDRAFT PROTECTION SERVICES FEATURING AN OPTION TO OBTAIN COVERAGE FOR OVERDRAFT PROTECTION SERVICES ON CONSUMER CHECKING ACCOUNTS (U.S. CLS. 100, 101 AND 102).

FIRST USE 4-30-2010; IN COMMERCE 4-30-2010.

CLASS 36—(Continued).

4,017,318. CAIDAN MANAGEMENT COMPANY, LLC, DETROIT, MI. SN 85-115,177. FILED P.R. 8-25-2010; AM. S.R. 12-8-2010.

HEALTH PLAN OF MICHIGAN

THE MARK CONSISTS OF STANDARD CHARACTERS WITHOUT CLAIM TO ANY PARTICULAR FONT, STYLE, SIZE, OR COLOR.

NO CLAIM IS MADE TO THE EXCLUSIVE RIGHT TO USE "HEALTH PLAN", APART FROM THE MARK AS SHOWN.

FOR ADMINISTRATION OF PRE-PAID HEALTH CARE PLANS (U.S. CLS. 100, 101 AND 102).

FIRST USE 9-0-1995; IN COMMERCE 9-0-1995.

4,017,332. THE TRUSTEES OF THE SAN DIEGO FIREFIGHTERS BENEVOLENT FUND, SAN DIEGO, CA. SN 85-126,339. FILED P.R. 9-9-2010; AM. S.R. 6-20-2011.

FirefighterAid

THE MARK CONSISTS OF STANDARD CHARACTERS WITHOUT CLAIM TO ANY PARTICULAR FONT, STYLE, SIZE, OR COLOR.

FOR CHARITABLE FUNDRAISING SERVICES FOR THE FAMILIES OF INJURED AND DECEASED FIREFIGHTERS; CHARITABLE SERVICES, NAMELY, PROVIDING FINANCIAL ASSISTANCE AND FINANCIAL SUPPORT TO THE FAMILIES OF INJURED AND DECEASED FIREFIGHTERS; CHARITABLE SERVICES, NAMELY, PROVIDING FINANCIAL ASSISTANCE AND FINANCIAL SUPPORT TO LOW-INCOME ELDERLY AND DISABLED FIREFIGHTERS; CHARITABLE FUNDRAISING SERVICES FOR EDUCATIONAL AND COLLEGE SCHOLARSHIPS AND FINANCIAL ASSISTANCE FOR FUTURE LEADERS RELATED TO THE FIELD OF FIREFIGHTING; CHARITABLE SERVICES, NAMELY, PROVIDING EDUCATIONAL AND COLLEGE SCHOLARSHIPS AND FINANCIAL ASSISTANCE FOR FUTURE LEADERS RELATED TO THE FIELD OF FIREFIGHTING; CHARITABLE SERVICES, NAMELY, PROVIDING FINANCIAL ASSISTANCE AND FINANCIAL SUPPORT FOR THE FUNERARY AND BEREAVEMENT NEEDS OF THE FAMILIES OF DECEASED FIREFIGHTERS (U.S. CLS. 100, 101 AND 102).

FIRST USE 2-14-2010; IN COMMERCE 8-22-2010.

CLASS 36—(Continued).

4,017,391. EZ PREPAID LLC, DBA EZ PREPAID LLC, BALTIMORE, MD. SN 85-248,463. FILED 2-22-2011.

EZ Prepaid

THE MARK CONSISTS OF STANDARD CHARACTERS WITHOUT CLAIM TO ANY PARTICULAR FONT, STYLE, SIZE, OR COLOR.

NO CLAIM IS MADE TO THE EXCLUSIVE RIGHT TO USE "PREPAID", APART FROM THE MARK AS SHOWN.

FOR PREPAID CARD SERVICES IN THE NATURE OF MAKING PAYMENT FOR ADDING AIRTIME TO PREPAID OR PAY-AS-YOU-GO WIRELESS SERVICES (U.S. CLS. 100, 101 AND 102).

FIRST USE 2-10-2011; IN COMMERCE 2-10-2011.

4,017,399. FABELLA, CHARLES, BROOKLYN, NY. SN 85-265,338. FILED P.R. 3-12-2011; AM. S.R. 6-18-2011.

SPECIALIZING IN ALL YOUR
REAL ESTATE NEEDS

THE MARK CONSISTS OF STANDARD CHARACTERS WITHOUT CLAIM TO ANY PARTICULAR FONT, STYLE, SIZE, OR COLOR.

FOR REAL ESTATE BROKERAGE; REAL ESTATE CONSULTANCY; REAL ESTATE LISTING; REAL ESTATE AGENCY (U.S. CLS. 100, 101 AND 102).

FIRST USE 6-1-2008; IN COMMERCE 6-1-2008.

4,017,417. VO GROUP, LLC, DBA VACATION OWNERSHIP GROUP, EGG HARBOR TOWNSHIP, NJ. SN 85-287,918. FILED P.R. 4-6-2011; AM. S.R. 7-14-2011.

VACATION OWNERSHIP GROUP

THE MARK CONSISTS OF STANDARD CHARACTERS WITHOUT CLAIM TO ANY PARTICULAR FONT, STYLE, SIZE, OR COLOR.

FOR VACATION REAL ESTATE TIMESHARE SERVICES (U.S. CLS. 100, 101 AND 102).

FIRST USE 4-1-2010; IN COMMERCE 4-1-2010.

CLASS 36—(Continued).

4,017,421. INDIANA WHOLESALE DEALERS INC., HAMMOND, IN. SN 85-291,080. FILED P.R. 4-9-2011; AM. S.R. 7-18-2011.

Indiana Wholesale Dealers

THE MARK CONSISTS OF STANDARD CHARACTERS WITHOUT CLAIM TO ANY PARTICULAR FONT, STYLE, SIZE, OR COLOR.

FOR MANAGEMENT OF BUILDINGS (U.S. CLS. 100, 101 AND 102).

FIRST USE 7-12-2007; IN COMMERCE 2-9-2009.

CLASS 37—CONSTRUCTION AND REPAIR

4,017,274. IT OUTLET, INC., SIOUX FALLS, SD. SN 77-637,102. FILED P.R. 12-19-2008; AM. S.R. 5-9-2011.

IT OUTLET

THE MARK CONSISTS OF STANDARD CHARACTERS WITHOUT CLAIM TO ANY PARTICULAR FONT, STYLE, SIZE, OR COLOR.

OWNER OF U.S. REG. NO. 3,401,072.

NO CLAIM IS MADE TO THE EXCLUSIVE RIGHT TO USE "IT", APART FROM THE MARK AS SHOWN.

FOR INSTALLATION, MAINTENANCE AND REPAIR OF COMPUTER HARDWARE, COMPUTER NETWORKS, AND COMPUTER HARDWARE TECHNOLOGY DEVICES (U.S. CLS. 100, 103 AND 106).

FIRST USE 0-0-2009; IN COMMERCE 0-0-2009.

4,017,287. RAGUSA, ANTHONY J., JR., WILLIAMSVILLE, NY. SN 77-904,237. FILED P.R. 1-4-2010; AM. S.R. 9-29-2010.

WHITE BOX SERVICE

THE MARK CONSISTS OF STANDARD CHARACTERS WITHOUT CLAIM TO ANY PARTICULAR FONT, STYLE, SIZE, OR COLOR.

NO CLAIM IS MADE TO THE EXCLUSIVE RIGHT TO USE "SERVICE", APART FROM THE MARK AS SHOWN.

FOR REPAIR OF CONSUMER ELECTRONICS (U.S. CLS. 100, 103 AND 106).

FIRST USE 9-2-2009; IN COMMERCE 10-0-2009.

CLASS 37—(Continued).

4,017,312. BENSON AND CURTIS CORP., PASADENA, CA. SN 85-108,209. FILED P.R. 8-16-2010; AM. S.R. 6-15-2011.

Family Owned, Factory Trained

THE MARK CONSISTS OF STANDARD CHARACTERS WITHOUT CLAIM TO ANY PARTICULAR FONT, STYLE, SIZE, OR COLOR.

FOR AUTOMOTIVE MAINTENANCE AND REPAIR (U.S. CLS. 100, 103 AND 106).

FIRST USE 11-1-2009; IN COMMERCE 12-1-2009.

4,017,394. JEFFREY SORRELL, SACHSE, TX. SN 85-261,054. FILED P.R. 3-8-2011; AM. S.R. 6-16-2011.

ULTIMATE BILLIARD SERVICE

THE MARK CONSISTS OF STANDARD CHARACTERS WITHOUT CLAIM TO ANY PARTICULAR FONT, STYLE, SIZE, OR COLOR.

NO CLAIM IS MADE TO THE EXCLUSIVE RIGHT TO USE "BILLIARD SERVICE", APART FROM THE MARK AS SHOWN.

FOR POOL AND BILLIARD TABLE REPAIR AND MAINTENANCE SERVICES; POOL AND BILLIARD TABLE MOVING, BREAK DOWN, AND SET UP SERVICES (U.S. CLS. 100, 103 AND 106).

FIRST USE 0-0-2007; IN COMMERCE 0-0-2007.

CLASS 38—COMMUNICATION

4,017,333. ZUMBOX, INC., WESTLAKE VILLAGE, CA. SN 85-127,575. FILED P.R. 9-11-2010; AM. S.R. 6-22-2011.

DIGITAL POSTAL MAIL

THE MARK CONSISTS OF STANDARD CHARACTERS WITHOUT CLAIM TO ANY PARTICULAR FONT, STYLE, SIZE, OR COLOR.

OWNER OF U.S. REG. NO. 3,562,292.

NO CLAIM IS MADE TO THE EXCLUSIVE RIGHT TO USE "POSTAL MAIL", APART FROM THE MARK AS SHOWN.

FOR ELECTRONIC TRANSMISSION OF MAIL, MESSAGES, AND DATA; PROVIDING ACCESS TO ONLINE DATABASE TO ENABLE AUTHORIZED USERS TO SEARCH THEIR MAIL, MESSAGES, AND DATA; ELECTRONIC MAIL SERVICES (U.S. CLS. 100, 101 AND 104).

FIRST USE 5-26-2010; IN COMMERCE 5-26-2010.

CLASS 38—(Continued).

4,017,360. T-MOBILE USA, INC., BELLEVUE, WA. SN 85-167,835. FILED P.R. 11-3-2010; AM. S.R. 6-14-2011.

AMERICA'S LARGEST 4G NETWORK

THE MARK CONSISTS OF STANDARD CHARACTERS WITHOUT CLAIM TO ANY PARTICULAR FONT, STYLE, SIZE, OR COLOR.

NO CLAIM IS MADE TO THE EXCLUSIVE RIGHT TO USE "4G NETWORK", APART FROM THE MARK AS SHOWN.

FOR TELECOMMUNICATIONS SERVICES, NAMELY, WIRELESS VOICE AND DATA TRANSMISSION, TWO WAY WIRELESS TRANSMISSION OF EMAIL AND TEXT BETWEEN WIRELESS TELECOMMUNICATION TERMINALS AND COMPUTERS, AND PROVIDING MULTIPLE-USER ACCESS TO A GLOBAL COMPUTER NETWORK (U.S. CLS. 100, 101 AND 104).

FIRST USE 11-2-2010; IN COMMERCE 11-2-2010.

CLASS 39—TRANSPORTATION AND STORAGE

4,017,362. GREAT SAFARIS, LLC, GLENDALE, CA. SN 85-169,718. FILED P.R. 11-4-2010; AM. S.R. 6-30-2011.

GREAT SAFARIS

THE MARK CONSISTS OF STANDARD CHARACTERS WITHOUT CLAIM TO ANY PARTICULAR FONT, STYLE, SIZE, OR COLOR.

FOR ARRANGING, CONDUCTING AND OPERATING TRAVEL TOURS; ARRANGING, CONDUCTING AND OPERATING OUTDOOR ADVENTURE TOURS; TOUR GUIDE SERVICES; TRAVEL GUIDE SERVICES; ARRANGEMENT OF TRAVEL TOURS; ONLINE TRIP AND TRAVEL RESERVATION SERVICES; PROVIDING AN ON-LINE COMPUTER DATABASE IN THE FIELD OF TRAVEL INFORMATION SERVICES; TRAVEL AND TOUR INFORMATION SERVICES; TRAVEL INFORMATION SERVICES (U.S. CLS. 100 AND 105).

FIRST USE 11-1-2010; IN COMMERCE 11-1-2010.

CLASS 39—(Continued).

4,017,420. OUTER BANKS FISHING CHARTERS, KILL DEVIL HILLS, NC. SN 85-290,820. FILED P.R. 4-8-2011; AM. S.R. 7-11-2011.

Outer Banks Fishing Charters

THE MARK CONSISTS OF STANDARD CHARACTERS WITHOUT CLAIM TO ANY PARTICULAR FONT, STYLE, SIZE, OR COLOR.

NO CLAIM IS MADE TO THE EXCLUSIVE RIGHT TO USE "FISHING CHARTERS", APART FROM THE MARK AS SHOWN.

FOR CONDUCTING FISHING CHARTERS (U.S. CLS. 100 AND 105).

FIRST USE 5-15-2007; IN COMMERCE 5-15-2007.

CLASS 41—EDUCATION AND ENTERTAINMENT

4,017,277. THE INTERNATIONAL SOCIETY OF DNA VACCINES, BLUE BELL, PA. SN 77-750,559. FILED P.R. 6-2-2009; AM. S.R. 11-4-2010.

International Society of DNA Vaccines

THE MARK CONSISTS OF STANDARD CHARACTERS WITHOUT CLAIM TO ANY PARTICULAR FONT, STYLE, SIZE, OR COLOR.

NO CLAIM IS MADE TO THE EXCLUSIVE RIGHT TO USE "INTERNATIONAL SOCIETY", APART FROM THE MARK AS SHOWN.

FOR EDUCATIONAL SERVICES IN THE SCIENTIFIC FIELD OF DNA VACCINES RENDERED BY CONDUCTING CONFERENCES AND SEMINARS, AND THE DISTRIBUTION OF PRINTED PUBLICATIONS AND ELECTRONIC MEDIA IN CONJUNCTION THEREWITH (U.S. CLS. 100, 101 AND 107).

FIRST USE 8-0-2008; IN COMMERCE 8-0-2008.

4,017,314. SPORTSMEN OF NORTH AMERICA L.P., MESQUITE, TX. SN 85-110,443. FILED P.R. 8-18-2010; AM. S.R. 5-27-2011.

SPORTSMEN VIDEO PRODUCTIONS

THE MARK CONSISTS OF STANDARD CHARACTERS WITHOUT CLAIM TO ANY PARTICULAR FONT, STYLE, SIZE, OR COLOR.

CLASS 41—(Continued).

NO CLAIM IS MADE TO THE EXCLUSIVE RIGHT TO USE "VIDEO PRODUCTIONS", APART FROM THE MARK AS SHOWN.

FOR ENTERTAINMENT, NAMELY, PRODUCTION OF TELEVISION SHOWS (U.S. CLS. 100, 101 AND 107).

FIRST USE 10-0-2007; IN COMMERCE 10-0-2007.

4,017,319. INSTITUTE OF INTELLECTUAL PROPERTY AND SOCIAL JUSTICE, INC., AKA IIPSI, INC., COLUMBIA, MD. SN 85-116,091. FILED P.R. 8-26-2010; AM. S.R. 7-12-2011.

Institute of Intellectual Property and Social Justice

THE MARK CONSISTS OF STANDARD CHARACTERS WITHOUT CLAIM TO ANY PARTICULAR FONT, STYLE, SIZE, OR COLOR.

NO CLAIM IS MADE TO THE EXCLUSIVE RIGHT TO USE "INSTITUTE", APART FROM THE MARK AS SHOWN.

FOR EDUCATIONAL SERVICES, NAMELY, CONDUCTING CLASSES, SYMPOSIA, AND PROGRAMS IN THE FIELDS OF INTELLECTUAL PROPERTY, LAW, AND SOCIAL JUSTICE, AND DISTRIBUTION OF TRAINING MATERIALS IN CONNECTION THEREWITH (U.S. CLS. 100, 101 AND 107).

FIRST USE 10-1-2002; IN COMMERCE 10-1-2002.

4,017,325. ARABIAN HORSE ASSOCIATION, AURORA, CO. SN 85-123,379. FILED P.R. 9-4-2010; AM. S.R. 6-20-2011.



ARABIAN BREEDERS SWEEPSTAKES

OWNER OF U.S. REG. NO. 1,576,928.

NO CLAIM IS MADE TO THE EXCLUSIVE RIGHT TO USE "ARABIAN BREEDERS SWEEPSTAKES", APART FROM THE MARK AS SHOWN.

THE MARK CONSISTS OF THE WORDS "ARABIAN BREEDERS SWEEPSTAKES" AND THE DESIGN OF A HORSE. THE WORD "ARABIAN" APPEARS TO THE LEFT OF THE HORSE DESIGN THE WORDS "BREEDERS SWEEPSTAKES" APPEAR BELOW THE WORD "ARABIAN" AND THE HORSE DESIGN. A SOLID LINE APPEARS ABOVE THE WORDS "BREEDERS SWEEPSTAKES".

FOR ENTERTAINMENT SERVICES IN THE NATURE OF ARABIAN AND HALF-ARABIAN HORSE COMPETITIONS (U.S. CLS. 100, 101 AND 107).

FIRST USE 6-0-2007; IN COMMERCE 6-0-2007.

CLASS 41—(Continued).

4,017,339. VALUE FORWARD GROUP, INC., PEACHTREE CITY, GA. SN 85-135,205. FILED P.R. 9-22-2010; AM. S.R. 6-20-2011.

BUSINESS GROWTH SPECIALISTS

THE MARK CONSISTS OF STANDARD CHARACTERS WITHOUT CLAIM TO ANY PARTICULAR FONT, STYLE, SIZE, OR COLOR.

FOR PROFESSIONAL COACHING SERVICES IN THE FIELD OF HELPING MANAGEMENT EXECUTIVE IMPROVE AND GROW THEIR BUSINESSES THROUGH PREMEDITATED THOUGHT, PLANNING AND ACTION STEPS AND THE INTEGRATION OF SALES, MARKETING, STRATEGY AND FINANCIAL MANAGEMENT USING FORMULATIONS OF BEST PRACTICES FOR BUSINESS MANAGEMENT (U.S. CLS. 100, 101 AND 107).

FIRST USE 12-31-2003; IN COMMERCE 12-31-2003.

4,017,344. LABORATORY INSTITUTE OF MERCHANDISING, NEW YORK, NY. SN 85-140,672. FILED P.R. 9-29-2010; AM. S.R. 6-20-2011.

FASHION LAB

THE MARK CONSISTS OF STANDARD CHARACTERS WITHOUT CLAIM TO ANY PARTICULAR FONT, STYLE, SIZE, OR COLOR.

FOR EDUCATIONAL SERVICES, NAMELY PROVIDING PRE-COLLEGE COURSES AND COURSES AT THE HIGH SCHOOL LEVEL, ALL IN THE FIELD OF FASHION (U.S. CLS. 100, 101 AND 107).

FIRST USE 4-30-2007; IN COMMERCE 4-30-2007.

4,017,351. SYNTELESYS EDUCATIONAL SERVICES, MONTEREY PARK, CA. SN 85-146,942. FILED P.R. 10-7-2010; AM. S.R. 5-20-2011.

ACADEMIA DE SERVICIO DE TUTORIA

THE MARK CONSISTS OF STANDARD CHARACTERS WITHOUT CLAIM TO ANY PARTICULAR FONT, STYLE, SIZE, OR COLOR.

CLASS 41—(Continued).

THE ENGLISH TRANSLATION OF THE MARK "ACADEMIA DE SERVICIO DE TUTORIA" IS "TUTORING SERVICE ACADEMY".

FOR EDUCATION SERVICES, NAMELY, PROVIDING TUTORING IN THE FIELDS OF ENGLISH, MATH, AND STUDY SKILLS (U.S. CLS. 100, 101 AND 107).

FIRST USE 3-1-2009; IN COMMERCE 3-1-2009.

4,017,358. THE DAILY HOLDINGS, INC., WILMINGTON, DE. SN 85-159,343. FILED P.R. 10-22-2010; AM. S.R. 6-14-2011.



THE COLOR(S) WHITE, ROYAL BLUE AND NAVY BLUE IS/ARE CLAIMED AS A FEATURE OF THE MARK.

THE MARK CONSISTS OF TWO ROUNDED-CORNER RECTANGLES. THE LEFT RECTANGLE IS SMALLER IN LENGTH THAN THE RIGHT RECTANGLE. THE LEFT RECTANGLE IS ROYAL BLUE AND CONTAINS THE WORD "THE" IN WHITE LETTERS IN STYLIZED FORM. THE RIGHT RECTANGLE IS WHITE AND CONTAINS THE WORD "DAILY" IN NAVY BLUE LETTERS IN STYLIZED FORM. THE DOTTED LINES AROUND THE ROYAL BLUE AND WHITE RECTANGLES ARE NOT CLAIMED AS A FEATURE OF THE MARK AND ARE PRESENTED ONLY TO SHOW PLACEMENT AND THE BOUNDARIES OF THE ROYAL BLUE AND WHITE RECTANGLES. THE COLOR BLACK IS NOT CLAIMED AS A FEATURE OF THE MARK.

FOR ENTERTAINMENT SERVICES, NAMELY, THE PROVISION OF AUDIO, VIDEO, TEXT AND PHOTOGRAPHIC CONTENT DISTRIBUTED VIA MOBILE AND STATIONARY CONSUMER ELECTRONIC DEVICES (U.S. CLS. 100, 101 AND 107).

FIRST USE 2-2-2011; IN COMMERCE 2-2-2011.

4,017,365. LORENZANA & ASSOCIATES, LLC, MORTON GROVE, IL. SN 85-173,255. FILED P.R. 11-10-2010; AM. S.R. 6-9-2011.

DANCEFLIX

THE MARK CONSISTS OF STANDARD CHARACTERS WITHOUT CLAIM TO ANY PARTICULAR FONT, STYLE, SIZE, OR COLOR.

FOR MOTION PICTURE AND VIDEO RENTAL SERVICES (U.S. CLS. 100, 101 AND 107).

FIRST USE 6-7-2011; IN COMMERCE 6-7-2011.

CLASS 41—(Continued).

4,017,366. LIFE TRANSITIONS ADVISORS, LLC, NOR-CROSS, GA. SN 85-173,879. FILED P.R. 11-10-2010; AM. S.R. 7-19-2011.

CLASS 41—(Continued).

4,017,367. LIFE TRANSITIONS ADVISORS, LLC, NOR-CROSS, GA. SN 85-173,890. FILED P.R. 11-10-2010; AM. S.R. 7-19-2011.

**THE FAMILY CARE
CONVERSATION**

THE FAMILY CARE SOLUTION

THE MARK CONSISTS OF STANDARD CHARACTERS WITHOUT CLAIM TO ANY PARTICULAR FONT, STYLE, SIZE, OR COLOR.

FOR EDUCATION AND TRAINING SERVICES, NAMELY, CONDUCTING SEMINARS, WORKSHOPS, AND KEYNOTE SPEECHES IN THE FIELD OF FINANCIAL PLANNING AS IT RELATES TO FINANCIAL PLANNING AND ESTATE PLANNING SERVICES FOR AGING PARENTS, THE ADULT CHILDREN OF AGING PARENTS, AND FAMILIES WITH SPECIAL NEEDS CHILDREN, ALL PROVIDED TO FINANCIAL PLANNERS, FINANCIAL ADVISORS, INSURANCE AGENTS, SECURITIES BROKER/DEALERS AND FINANCIAL PRODUCT DISTRIBUTORS, AND PROFESSIONAL ASSOCIATIONS IN THE INSURANCE AND FINANCIAL PLANNING FIELDS; EDUCATION SERVICES, NAMELY, PROVIDING ON-GOING CONTINUING EDUCATION SERVICES, NAMELY, ON-SITE WORKSHOPS, WEB-BASED WORKSHOPS DESIGNED TO MEET CONTINUING EDUCATION REQUIREMENTS FOR HOLDERS OF CERTAIN PROFESSIONAL DESIGNATIONS AND INSURANCE LICENSES AND DISTRIBUTION OF EDUCATIONAL MATERIALS IN THE NATURE OF WHITE PAPERS, BOOKS, AND VIDEOS IN CONNECTION THEREWITH, ALL PROVIDED TO FINANCIAL PLANNERS, FINANCIAL ADVISORS, INSURANCE AGENTS, SECURITIES BROKER/DEALERS AND FINANCIAL PRODUCT DISTRIBUTORS, AND PROFESSIONAL ASSOCIATIONS IN THE INSURANCE AND FINANCIAL PLANNING FIELDS (U.S. CLS. 100, 101 AND 107).

FIRST USE 11-16-2010; IN COMMERCE 11-16-2010.

THE MARK CONSISTS OF STANDARD CHARACTERS WITHOUT CLAIM TO ANY PARTICULAR FONT, STYLE, SIZE, OR COLOR.

FOR EDUCATION AND TRAINING SERVICES, NAMELY, CONDUCTING SEMINARS, WORKSHOPS, AND KEYNOTE SPEECHES IN THE FIELD OF FINANCIAL PLANNING AS IT RELATES TO FINANCIAL PLANNING AND ESTATE PLANNING SERVICES FOR AGING PARENTS, THE ADULT CHILDREN OF AGING PARENTS, AND FAMILIES WITH SPECIAL NEEDS CHILDREN, ALL PROVIDED TO FINANCIAL PLANNERS, FINANCIAL ADVISORS, INSURANCE AGENTS, SECURITIES BROKER/DEALERS AND FINANCIAL PRODUCT DISTRIBUTORS, AND PROFESSIONAL ASSOCIATIONS IN THE INSURANCE AND FINANCIAL PLANNING FIELDS; EDUCATION SERVICES, NAMELY, PROVIDING ON-GOING CONTINUING EDUCATION SERVICES, NAMELY, ON-SITE WORKSHOPS, WEB-BASED WORKSHOPS DESIGNED TO MEET CONTINUING EDUCATION REQUIREMENTS FOR HOLDERS OF CERTAIN PROFESSIONAL DESIGNATIONS AND INSURANCE LICENSES AND DISTRIBUTION OF EDUCATIONAL MATERIALS IN THE NATURE OF WHITE PAPERS, BOOKS, AND VIDEOS IN CONNECTION THEREWITH, ALL PROVIDED TO FINANCIAL PLANNERS, FINANCIAL ADVISORS, INSURANCE AGENTS, SECURITIES BROKER/DEALERS AND FINANCIAL PRODUCT DISTRIBUTORS, AND PROFESSIONAL ASSOCIATIONS IN THE INSURANCE AND FINANCIAL PLANNING FIELDS (U.S. CLS. 100, 101 AND 107).

FIRST USE 11-16-2010; IN COMMERCE 11-16-2010.

CLASS 41—(Continued).

4,017,368. LIFE TRANSITIONS ADVISORS, LLC, NORCROSS, GA. SN 85-173,897. FILED P.R. 11-10-2010; AM. S.R. 7-19-2011.

THE FAMILY CARE CULTURE

THE MARK CONSISTS OF STANDARD CHARACTERS WITHOUT CLAIM TO ANY PARTICULAR FONT, STYLE, SIZE, OR COLOR.

FOR EDUCATION AND TRAINING SERVICES, NAMELY, CONDUCTING SEMINARS, WORKSHOPS, AND KEYNOTE SPEECHES IN THE FIELD OF FINANCIAL PLANNING AS IT RELATES TO FINANCIAL PLANNING AND ESTATE PLANNING SERVICES FOR AGING PARENTS, THE ADULT CHILDREN OF AGING PARENTS, AND FAMILIES WITH SPECIAL NEEDS CHILDREN, ALL PROVIDED TO FINANCIAL PLANNERS, FINANCIAL ADVISORS, INSURANCE AGENTS, SECURITIES BROKER/DEALERS AND FINANCIAL PRODUCT DISTRIBUTORS, AND PROFESSIONAL ASSOCIATIONS IN THE INSURANCE AND FINANCIAL PLANNING FIELDS; EDUCATION SERVICES, NAMELY, PROVIDING ON-GOING CONTINUING EDUCATION SERVICES, NAMELY, ON-SITE WORKSHOPS, WEB-BASED WORKSHOPS DESIGNED TO MEET CONTINUING EDUCATION REQUIREMENTS FOR HOLDERS OF CERTAIN PROFESSIONAL DESIGNATIONS AND INSURANCE LICENSES AND DISTRIBUTION OF EDUCATIONAL MATERIALS IN THE NATURE OF WHITE PAPERS, BOOKS, AND VIDEOS IN CONNECTION THEREWITH, ALL PROVIDED TO FINANCIAL PLANNERS, FINANCIAL ADVISORS, INSURANCE AGENTS, SECURITIES BROKER/DEALERS AND FINANCIAL PRODUCT DISTRIBUTORS, AND PROFESSIONAL ASSOCIATIONS IN THE INSURANCE AND FINANCIAL PLANNING FIELDS (U.S. CLS. 100, 101 AND 107).

FIRST USE 11-16-2010; IN COMMERCE 11-16-2010.

4,017,369. THE OSS SOCIETY, INC., MCLEAN, VA. SN 85-174,324. FILED P.R. 11-11-2010; AM. S.R. 6-30-2011.

OSS MUSEUM

THE MARK CONSISTS OF STANDARD CHARACTERS WITHOUT CLAIM TO ANY PARTICULAR FONT, STYLE, SIZE, OR COLOR.

NO CLAIM IS MADE TO THE EXCLUSIVE RIGHT TO USE "MUSEUM", APART FROM THE MARK AS SHOWN, FOR MUSEUM SERVICES (U.S. CLS. 100, 101 AND 107).

FIRST USE 2-28-2011; IN COMMERCE 6-30-2011.

CLASS 41—(Continued).

4,017,381. GREEN HILL HEALTHCARE COMMUNICATIONS, LLC, MONROE TOWNSHIP, NJ. SN 85-213,700. FILED P.R. 1-10-2011; AM. S.R. 7-7-2011.

THE ONCOLOGY NURSE-APN/PA

THE MARK CONSISTS OF STANDARD CHARACTERS WITHOUT CLAIM TO ANY PARTICULAR FONT, STYLE, SIZE, OR COLOR.

OWNER OF U.S. REG. NOS. 3,621,208 AND 3,624,945.
FOR ONLINE EDUCATIONAL SERVICES, NAMELY, PROVIDING CONTINUING EDUCATION COURSES AND EXAMS IN THE FIELDS OF HEMATOLOGY, ONCOLOGY AND NURSING VIA A GLOBAL COMPUTER INFORMATION NETWORK; PROVIDING ONLINE INFORMATION ABOUT CONTINUING EDUCATION IN THE FIELDS OF HEMATOLOGY, ONCOLOGY AND NURSING (U.S. CLS. 100, 101 AND 107).

FIRST USE 6-1-2010; IN COMMERCE 6-1-2010.

4,017,392. SCRIPPS, ELIZABETH, PITTSBURGH, PA. SN 85-256,494. FILED P.R. 3-3-2011; AM. S.R. 6-17-2011.

POLO GIRLS

THE MARK CONSISTS OF STANDARD CHARACTERS WITHOUT CLAIM TO ANY PARTICULAR FONT, STYLE, SIZE, OR COLOR.

FOR ENTERTAINMENT SERVICES, NAMELY, PARTICIPATION IN THE SPORT OF POLO; ORGANIZING AND CONDUCTING POLO SPORTING EVENTS FOR THE PURPOSE OF FUNDRAISING; ENTERTAINMENT SERVICES, NAMELY, PERFORMING AND COMPETING IN POLO SPORTS EVENTS; ENTERTAINMENT IN THE NATURE OF ON-GOING TELEVISION PROGRAMS IN THE FIELD OF POLO SPORTS EVENTS, AND POLO LIFESTYLE (U.S. CLS. 100, 101 AND 107).

FIRST USE 4-1-2009; IN COMMERCE 11-5-2009.

CLASS 41—(Continued).

4,017,393. EAGLE PUBLISHING, INC., WASHINGTON, DC. SN 85-256,970. FILED P.R. 3-3-2011; AM. S.R. 7-11-2011.

FAMILY EVENTS

THE MARK CONSISTS OF STANDARD CHARACTERS WITHOUT CLAIM TO ANY PARTICULAR FONT, STYLE, SIZE, OR COLOR.

FOR PROVIDING ON-LINE NEWSLETTERS IN THE FIELD OF PARENTING, POP CULTURE, AND TOPICS AND ADVICE AND INFORMATION OF GENERAL INTEREST TO FAMILIES (U.S. CLS. 100, 101 AND 107). FIRST USE 2-3-2011; IN COMMERCE 2-3-2011.

4,017,396. THE INDIANA SOCIETY FOR THE PREVENTION OF CRUELTY TO ANIMALS, AKA ISPCA, INDIANAPOLIS, IN. SN 85-264,377. FILED P.R. 3-11-2011; AM. S.R. 6-21-2011.

Indysocialdiary.com

THE MARK CONSISTS OF STANDARD CHARACTERS WITHOUT CLAIM TO ANY PARTICULAR FONT, STYLE, SIZE, OR COLOR.

FOR ENTERTAINMENT SERVICES, NAMELY, PROVIDING NON-DOWNLOADABLE ELECTRONIC PUBLICATIONS IN THE NATURE OF MAGAZINES FEATURING A SOCIAL AND HISTORICAL CHRONICLE OF LIFE IN INDIANAPOLIS, GOSSIP, HEALTH, FINANCE, EVENTS, SHOPPING, PHILANTHROPY, POLITICS AND BUSINESS (U.S. CLS. 100, 101 AND 107). FIRST USE 5-1-2010; IN COMMERCE 5-1-2010.

4,017,403. RUDIN, DALE M, COLUMBIA, TN. SN 85-272,522. FILED P.R. 3-21-2011; AM. S.R. 6-27-2011.

Unnatural Horsemanship

THE MARK CONSISTS OF STANDARD CHARACTERS WITHOUT CLAIM TO ANY PARTICULAR FONT, STYLE, SIZE, OR COLOR.

NO CLAIM IS MADE TO THE EXCLUSIVE RIGHT TO USE "HORSEMANSHIP", APART FROM THE MARK AS SHOWN.

FOR HORSE TRAINING (U.S. CLS. 100, 101 AND 107). FIRST USE 3-21-2011; IN COMMERCE 3-21-2011.

CLASS 41—(Continued).

4,017,408. THE AMERICAN PARALEGAL INSTITUTE, INC., SUFFERN, NY. SN 85-275,676. FILED P.R. 3-24-2011; AM. S.R. 6-22-2011.

National Paralegal College

THE MARK CONSISTS OF STANDARD CHARACTERS WITHOUT CLAIM TO ANY PARTICULAR FONT, STYLE, SIZE, OR COLOR.

FOR PROVIDING ON-LINE TRAINING COURSES IN THE FIELD OF BECOMING A PARALEGAL (U.S. CLS. 100, 101 AND 107).

FIRST USE 1-8-2007; IN COMMERCE 1-8-2007.

4,017,416. BODINE, PAUL ARTHUR, CHICAGO, IL. SN 85-287,665. FILED P.R. 4-6-2011; AM. S.R. 7-14-2011.

**Chicago School of Business
Architecture**

THE MARK CONSISTS OF STANDARD CHARACTERS WITHOUT CLAIM TO ANY PARTICULAR FONT, STYLE, SIZE, OR COLOR.

NO CLAIM IS MADE TO THE EXCLUSIVE RIGHT TO USE "BUSINESS ARCHITECTURE", APART FROM THE MARK AS SHOWN.

FOR EDUCATIONAL SERVICES, NAMELY, CONDUCTING CLASSES, WORKSHOPS, CONFERENCES, SPEECHES IN THE FIELD OF BUSINESS ARCHITECTURE AND DISTRIBUTION OF COURSE AND EDUCATIONAL MATERIALS IN CONNECTION THEREWITH (U.S. CLS. 100, 101 AND 107).

FIRST USE 2-1-2011; IN COMMERCE 2-1-2011.

4,017,419. PENNWELL CORPORATION, TULSA, OK. SN 85-289,899. FILED P.R. 4-8-2011; AM. S.R. 7-8-2011.

**POWER GENERATION
UNIVERSITY**

NO CLAIM IS MADE TO THE EXCLUSIVE RIGHT TO USE "UNIVERSITY", APART FROM THE MARK AS SHOWN.

FOR EDUCATIONAL SERVICES, NAMELY, PROVIDING ONLINE INSTRUCTION IN THE FIELD OF ENGINEERING (U.S. CLS. 100, 101 AND 107).

FIRST USE 4-15-2010; IN COMMERCE 4-15-2010.

CLASS 42—SCIENTIFIC AND COMPUTER SERVICES

CLASS 42—(Continued).

4,017,280. UTHERVERSE, INC., ZEPHR COVE, NV. SN 77-815,768. FILED P.R. 8-28-2009; AM. S.R. 6-3-2010.

VIRTUAL WORLD WEB

THE MARK CONSISTS OF STANDARD CHARACTERS WITHOUT CLAIM TO ANY PARTICULAR FONT, STYLE, SIZE, OR COLOR.

NO CLAIM IS MADE TO THE EXCLUSIVE RIGHT TO USE "VIRTUAL WORLD", APART FROM THE MARK AS SHOWN.

FOR PROVIDING A WEBSITE FEATURING ONLINE NON-DOWNLOADABLE SOFTWARE FOR OPERATING AND MAINTAINING A VIRTUAL WORLD FOR ENTERTAINMENT PURPOSES; PROVIDING A WEBSITE FEATURING ONLINE NON-DOWNLOADABLE SOFTWARE TO ENABLE MULTIPLE USERS TO CREATE, PARTICIPATE IN AND NAVIGATE THROUGH VIRTUAL WORLDS IN THE NATURE OF A SYSTEM OF INTERLINKED VIRTUAL WORLDS (U.S. CLS. 100 AND 101).

FIRST USE 9-29-2009; IN COMMERCE 9-29-2009.

4,017,316. ARECONT VISION LLC, GLENDALE, CA. SN 85-112,127. FILED P.R. 8-20-2010; AM. S.R. 7-19-2011.

MegaLab

THE MARK CONSISTS OF STANDARD CHARACTERS WITHOUT CLAIM TO ANY PARTICULAR FONT, STYLE, SIZE, OR COLOR.

FOR LABORATORY SERVICES FOR TESTING INTEGRATION OF VIDEO SECURITY CAMERAS WITH THE INDUSTRY'S VIDEO MANAGEMENT SOFTWARE (VMS) PLATFORMS (U.S. CLS. 100 AND 101).

FIRST USE 9-24-2010; IN COMMERCE 11-15-2010.

CLASS 42—(Continued).

4,017,357. GUILLOTTE, SUSAN, URBANNA, VA. SN 85-157,405. FILED P.R. 10-20-2010; AM. S.R. 7-14-2011.

The 99¢ Lobby

THE MARK CONSISTS OF STANDARD CHARACTERS WITHOUT CLAIM TO ANY PARTICULAR FONT, STYLE, SIZE, OR COLOR.

FOR PROVIDING A WEBSITE FEATURING TECHNOLOGY THAT ENABLES USERS TO SIMULTANEOUSLY DELIVER COMMUNIQUE TO HUNDREDS OF INDIVIDUALS VIA DATABASE, TO PRIVATELY ACCESS POLITICIANS, AND TO SORT AND FORMAT ADDITIONAL INFORMATION (U.S. CLS. 100 AND 101).
FIRST USE 1-1-2010; IN COMMERCE 9-17-2010.

CLASS 43—HOTEL AND RESTAURANT SERVICES

4,017,324. BALDWIN PARK FROYO LLC, DBA DELISH FROZEN YOGURT, LONGWOOD, FL. SN 85-123,324. FILED P.R. 9-4-2010; AM. S.R. 6-17-2011.

Delish Frozen Yogurt

THE MARK CONSISTS OF STANDARD CHARACTERS WITHOUT CLAIM TO ANY PARTICULAR FONT, STYLE, SIZE, OR COLOR.

NO CLAIM IS MADE TO THE EXCLUSIVE RIGHT TO USE "FROZEN YOGURT", APART FROM THE MARK AS SHOWN.

FOR FROZEN YOGURT SHOP SERVICES IN THE NATURE OF A RESTAURANT (U.S. CLS. 100 AND 101).
FIRST USE 7-22-2010; IN COMMERCE 7-22-2010.

4,017,404. SCOTT SULZER, DBA THE SANDWICH JOINT, LOS ANGELES, CA. SN 85-272,959. FILED P.R. 3-22-2011; AM. S.R. 6-27-2011.



NO CLAIM IS MADE TO THE EXCLUSIVE RIGHT TO USE "JOINT", APART FROM THE MARK AS SHOWN.

CLASS 43—(Continued).

THE COLOR(S) RED, WHITE, AND BLACK IS/ARE CLAIMED AS A FEATURE OF THE MARK.

THE MARK CONSISTS OF THE WORDS "THE SANDWICH JOINT" ARE IN WHITE WITH A BLACK BORDER AND THEY ARE SURROUNDED BY A RED OVAL AND THAT OVAL IS BORDERED WITH A WHITE AND BLACK BORDER, IN WHICH THE BLACK BORDER IS GREATER IN THICKNESS THAN THE WHITE BORDER.

FOR RESTAURANT AND CAFE SERVICES (U.S. CLS. 100 AND 101).

FIRST USE 4-1-1999; IN COMMERCE 6-22-2009.

4,017,422. WIINKYS LLC, DBA WIINKYS, SPRINGFIELD, VA. SN 85-291,178. FILED 4-10-2011.

Grilled Fresh

THE MARK CONSISTS OF STANDARD CHARACTERS WITHOUT CLAIM TO ANY PARTICULAR FONT, STYLE, SIZE, OR COLOR.

FOR CARRY-OUT RESTAURANTS; CONSULTATION SERVICES IN THE FIELD OF RESTAURANT MENU DEVELOPMENT; FAST FOOD AND NON-STOP RESTAURANT SERVICES; FAST-FOOD RESTAURANT SERVICES; FAST-FOOD RESTAURANTS; RESTAURANT; RESTAURANT SERVICES FEATURING SANDWICHES; RESTAURANT SERVICES FEATURING CHAR BROIL, GRILL, BAKE STEAM AND FRY FOOD; RESTAURANT SERVICES, INCLUDING SIT-DOWN SERVICE OF FOOD AND TAKE-OUT RESTAURANT SERVICES; RESTAURANT SERVICES, NAMELY, PROVIDING OF FOOD AND BEVERAGES FOR CONSUMPTION ON AND OFF THE PREMISES; RESTAURANTS (U.S. CLS. 100 AND 101).

FIRST USE 7-27-2010; IN COMMERCE 7-27-2010.

CLASS 44—MEDICAL, BEAUTY AND AGRICULTURAL SERVICES

4,017,304. L. PERRIGO COMPANY, ALLEGAN, MI. SN 85-067,347. FILED P.R. 6-21-2010; AM. S.R. 5-18-2011.

YOUR VITAMIN FINDER

THE MARK CONSISTS OF STANDARD CHARACTERS WITHOUT CLAIM TO ANY PARTICULAR FONT, STYLE, SIZE, OR COLOR.

NO CLAIM IS MADE TO THE EXCLUSIVE RIGHT TO USE "FINDER", APART FROM THE MARK AS SHOWN.

FOR A WEB-BASED INTERACTIVE INTERNET PORTAL IN WHICH A CONSUMER INPUTS PERSONAL DATA AND OBTAINS RECOMMENDATIONS REGARDING NUTRITIONAL SUPPLEMENTS THAT SHOULD BE TAKEN (U.S. CLS. 100 AND 101).

FIRST USE 1-1-2011; IN COMMERCE 1-1-2011.

CLASS 44—(Continued).

4,017,307. IAMMATTEO, MATTHEW, TA MEDICAL DOCTOR, MORRISTOWN, NJ. SN 85-094,309. FILED P.R. 7-27-2010; AM. S.R. 11-10-2010.

MADISON AVENUE OB-GYN

THE MARK CONSISTS OF STANDARD CHARACTERS WITHOUT CLAIM TO ANY PARTICULAR FONT, STYLE, SIZE, OR COLOR.

NO CLAIM IS MADE TO THE EXCLUSIVE RIGHT TO USE "OB-GYN", APART FROM THE MARK AS SHOWN.

FOR MEDICAL PRACTICE, NAMELY, OBSTETRICAL AND GYNECOLOGICAL SERVICES (U.S. CLS. 100 AND 101).

FIRST USE 9-1-2010; IN COMMERCE 9-1-2010.

4,017,340. CONTINENCE CENTER OF AMERICA, INC., PEORIA, AZ. SN 85-136,999. FILED P.R. 9-23-2010; AM. S.R. 6-22-2011.

CENTER FOR FEMALE SEXUAL HEALTH

THE MARK CONSISTS OF STANDARD CHARACTERS WITHOUT CLAIM TO ANY PARTICULAR FONT, STYLE, SIZE, OR COLOR.

NO CLAIM IS MADE TO THE EXCLUSIVE RIGHT TO USE "HEALTH", APART FROM THE MARK AS SHOWN.

FOR HEALTH CARE SERVICES (U.S. CLS. 100 AND 101).

FIRST USE 2-1-2008; IN COMMERCE 2-1-2008.

4,017,426. FESTFARE, INC, LAS VEGAS, NV. SN 85-303,124. FILED P.R. 4-24-2011; AM. S.R. 7-14-2011.

www.surrogatecenters.com

THE MARK CONSISTS OF STANDARD CHARACTERS WITHOUT CLAIM TO ANY PARTICULAR FONT, STYLE, SIZE, OR COLOR.

FOR MATERNAL SURROGACY SERVICES (U.S. CLS. 100 AND 101).

FIRST USE 4-24-2011; IN COMMERCE 4-24-2011.

CLASS 45—PERSONAL AND LEGAL SERVICES

CLASS 45—(Continued).

4,017,285. 3DCHAT.COM, LLC, MT. PLEASANT, SC. SN 77-863,246. FILED P.R. 11-2-2009; AM. S.R. 11-3-2010.

3Dsex

THE MARK CONSISTS OF STANDARD CHARACTERS WITHOUT CLAIM TO ANY PARTICULAR FONT, STYLE, SIZE, OR COLOR.

OWNER OF U.S. REG. NOS. 3,645,189 AND 3,933,635. FOR INTERNET-BASED DATING, NAMELY, CREATING AN ON-LINE COMMUNITY FOR REGISTERED USERS TO PARTICIPATE AS AVATARS, VIRTUAL REALITY ICONS AND GRAPHICAL IMAGES THAT REPRESENT PERSONS, AND ENGAGE IN AN ONLINE VIRTUAL WORLD WITH OTHER AVATARS THAT INCLUDES INTERNET-BASED DATING, SOCIAL INTRODUCTION, AND SOCIAL NETWORKING SERVICES (U.S. CLS. 100 AND 101).

FIRST USE 10-26-2010; IN COMMERCE 10-26-2010.

4,017,297. ARNOT + HALEY, PLLC, ETOWAH, NC. SN 85-005,784. FILED P.R. 4-3-2010; AM. S.R. 6-10-2011.

MINISTRY GENERAL COUNSEL

THE MARK CONSISTS OF STANDARD CHARACTERS WITHOUT CLAIM TO ANY PARTICULAR FONT, STYLE, SIZE, OR COLOR.

NO CLAIM IS MADE TO THE EXCLUSIVE RIGHT TO USE "GENERAL COUNSEL", APART FROM THE MARK AS SHOWN.

FOR LEGAL SERVICES (U.S. CLS. 100 AND 101). FIRST USE 2-19-2010; IN COMMERCE 2-20-2010.

CLASS 45—(Continued).

4,017,329. CITY OF ARLINGTON, ARLINGTON, TX. SN 85-125,937. FILED P.R. 9-9-2010; AM. S.R. 6-21-2011.



NO CLAIM IS MADE TO THE EXCLUSIVE RIGHT TO USE "POLICE", "ARLINGTONPD.ORG", AND THE COLORS BLUE AND WHITE, APART FROM THE MARK AS SHOWN.

THE COLOR(S) BLUE, RED, BLACK, AND WHITE IS/ARE CLAIMED AS A FEATURE OF THE MARK.

THE MARK CONSISTS OF A RED LINE BEGINNING ON THE LEFT SIDE OF THE REAR OF THE VEHICLE. THE RED LINE STOPS AND FIVE RED DIAGONAL LINES, THAT SLOPE TO THE RIGHT, CONTINUE TO THE LICENSE PLATE. TO THE RIGHT OF THE LICENSE PLATE ARE FIVE BLUE DIAGONAL LINES, THAT SLOPE TO THE LEFT, FOLLOWED BY A BLUE LINE THAT CONTINUES UNTIL IT REACHES THE RIGHT SIDE OF THE REAR OF THE VEHICLE. ABOVE THE LINES THE WORD "POLICE" APPEARS IN WHITE AND IS OUTLINED IN BLACK, AND RUNS HORIZONTALLY ALONG THE LENGTH OF THE VEHICLE. BELOW THE LINES THE WORDS "ARLINGTONPD.ORG" APPEAR IN WHITE, WITH NO OUTLINED COLOR, AND RUN HORIZONTALLY ALONG THE LENGTH OF THE REAR OF THE VEHICLE. THE VEHICLE IS NOT CLAIMED AS PART OF THE MARK AND THE DOTTED LINES SHOW THE PLACEMENT OF THE MARK.

FOR MUNICIPAL SERVICES, NAMELY, POLICE AND CIVIL PROTECTION (U.S. CLS. 100 AND 101). FIRST USE 7-1-2008; IN COMMERCE 7-1-2008.

4,017,330. CITY OF ARLINGTON, ARLINGTON, TX. SN 85-125,954. FILED P.R. 9-9-2010; AM. S.R. 6-21-2011.



NO CLAIM IS MADE TO THE EXCLUSIVE RIGHT TO USE "POLICE" AND THE COLORS BLUE AND WHITE, APART FROM THE MARK AS SHOWN.

THE COLOR(S) RED, BLUE, DARK SILVER, LIGHT SILVER, WHITE, AND BLACK IS/ARE CLAIMED AS A FEATURE OF THE MARK.

THE MARK CONSISTS OF A BLUE LINE BEGINNING AT THE FRONT OF THE VEHICLE, STOPPING AT THE FRONT WHEEL AND CONTINUING AGAIN AFTER THE WHEEL. THE BLUE LINE BEGINS AGAIN AFTER THE WHEEL TO MAKE THE LEFT SIDE OF A LETTER "A". AT THE TOP OF THE "A" THE BLUE LINE STOPS AND A NEW LINE BEGINS IN RED. THE RED LINE BEGINS A DECENT TO COMPLETE THE LETTER "A" AND CONTINUES UNTIL IT REACHES THE REAR WHEEL WHERE IT STOPS AND CONTINUES AGAIN AFTER THE WHEEL

CLASS 45—(Continued).

UNTIL IT REACHES THE REAR OF THE VEHICLE. CENTERED IN THE MIDDLE OF THE "A" IS A LIGHT SILVER COLORED STAR WITH A DARK SILVER LINING THAT RISES AT THE CENTER. TO THE RIGHT OF THE "A" THE WORD "POLICE" APPEARS IN WHITE WITH A BLACK OUTLINE WITH BLUE SHADOWING ON THE LETTERS, AND RUNS HORIZONTALLY ALONG THE LENGTH OF THE CAR. THE VEHICLE IS NOT CLAIMED AS PART OF THE MARK AND THE DOTTED LINES SHOW THE PLACEMENT OF THE MARK.

FOR MUNICIPAL SERVICES, NAMELY, POLICE AND CIVIL PROTECTION (U.S. CLS. 100 AND 101).
FIRST USE 7-1-2008; IN COMMERCE 7-1-2008.

4,017,331. CITY OF ARLINGTON, ARLINGTON, TX. SN 85-125,976. FILED P.R. 9-9-2010; AM. S.R. 6-21-2011.



NO CLAIM IS MADE TO THE EXCLUSIVE RIGHT TO USE "POLICE" AND THE COLORS WHITE AND BLUE, APART FROM THE MARK AS SHOWN.

THE COLOR(S) RED, BLUE, DARK SILVER, LIGHT SILVER, WHITE AND BLACK IS/ARE CLAIMED AS A FEATURE OF THE MARK.

THE MARK CONSISTS OF A BLUE LINE BEGINNING AT THE REAR OF THE VEHICLE, STOPPING AT THE REAR WHEEL AND CONTINUING AGAIN AFTER THE WHEEL. THE BLUE LINE BEGINS AGAIN TO MAKE THE RIGHT SIDE OF A LETTER "A". AT THE TOP OF THE "A" THE BLUE LINE STOPS AND A NEW LINE BEGINS IN RED. THE RED LINE BEGINS IN A DESCENT TO COMPLETE THE LETTER "A" AND CONTINUES UNTIL IT REACHES THE FRONT WHEEL WHERE IT STOPS AND CONTINUES AGAIN AFTER THE WHEEL UNTIL IT REACHES THE FRONT OF THE VEHICLE. CENTERED IN THE MIDDLE OF THE "A" IS A LIGHT SILVER COLORED STAR, WITH DARK SILVER LINING, THAT RISES AT THE CENTER. TO THE RIGHT OF THE LEFT OF THE "A" THE WORD "POLICE" APPEARS IN WHITE WITH A BLACK OUTLINE WITH BLUE SHADOWING ON THE LETTERS, AND RUNS HORIZONTALLY ALONG THE LENGTH OF THE CAR. THE VEHICLE IS NOT CLAIMED AS PART OF THE MARK AND THE DOTTED LINES SHOW THE PLACEMENT OF THE MARK.

FOR MUNICIPAL SERVICES, NAMELY, POLICE AND CIVIL PROTECTION (U.S. CLS. 100 AND 101).

FIRST USE 7-1-2008; IN COMMERCE 7-1-2008.

4,017,385. POST DIVORCE GROUP, LLC, BELLAIRE, TX. SN 85-235,209. FILED P.R. 2-6-2011; AM. S.R. 7-12-2011.

Post-Divorce Dating Club

THE MARK CONSISTS OF STANDARD CHARACTERS WITHOUT CLAIM TO ANY PARTICULAR FONT, STYLE, SIZE, OR COLOR.

CLASS 45—(Continued).

NO CLAIM IS MADE TO THE EXCLUSIVE RIGHT TO USE "DATING CLUB", APART FROM THE MARK AS SHOWN.

FOR COMPUTER DATING SERVICES; DATING SERVICES, NAMELY, PROVIDING AN ON-LINE COMPUTER DATABASE FEATURING SINGLE PEOPLE INTERESTED IN MEETING OTHER SINGLE PEOPLE; INTERNET BASED SOCIAL NETWORKING, INTRODUCTION, AND DATING SERVICES; PROVIDING A WEB SITE FEATURING INFORMATION AND CONTENT IN THE FIELDS OF PERSONAL RELATIONSHIPS, DATING AND FASHION; WEB SITE SERVICES FEATURING ON-LINE DATING CLUB (U.S. CLS. 100 AND 101).

FIRST USE 4-21-2011; IN COMMERCE 4-21-2011.

4,017,388. COLLIN COUNTY HUMANE SOCIETY, MCKINNEY, TX. SN 85-241,037. FILED P.R. 2-13-2011; AM. S.R. 7-18-2011.

COLLIN COUNTY HUMANE SOCIETY

THE MARK CONSISTS OF STANDARD CHARACTERS WITHOUT CLAIM TO ANY PARTICULAR FONT, STYLE, SIZE, OR COLOR.

NO CLAIM IS MADE TO THE EXCLUSIVE RIGHT TO USE "HUMANE SOCIETY", APART FROM THE MARK AS SHOWN.

FOR ANIMAL ADOPTION SERVICE, NAMELY, ARRANGING FOR DOGS AND CATS FROM SHELTERS TO BE PLACED IN HOMES (U.S. CLS. 100 AND 101).

FIRST USE 4-1-2008; IN COMMERCE 4-1-2008.

4,017,389. RATHBUN, JOHN M, MILLS RIVER, NC. SN 85-246,879. FILED P.R. 2-19-2011; AM. S.R. 6-26-2011.

THE INFO SITE

THE MARK CONSISTS OF STANDARD CHARACTERS WITHOUT CLAIM TO ANY PARTICULAR FONT, STYLE, SIZE, OR COLOR.

NO CLAIM IS MADE TO THE EXCLUSIVE RIGHT TO USE "SITE", APART FROM THE MARK AS SHOWN.

FOR PROVIDING ON-LINE INFORMATION IN THE FIELD OF SPIRITUALITY, SELF-HELP, AND PERSONAL EMPOWERMENT SUBJECT MATTERS (U.S. CLS. 100 AND 101).

FIRST USE 5-27-2011; IN COMMERCE 5-27-2011.

CLASS 45—(Continued).

4,017,402. IDENT-A-KID SERVICES OF AMERICA, INC., ST. PETERSBURG, FL. SN 85-272,309. FILED 3-21-2011.

ParentAlert

THE MARK CONSISTS OF STANDARD CHARACTERS WITHOUT CLAIM TO ANY PARTICULAR FONT, STYLE, SIZE, OR COLOR.

FOR SECURITY SERVICES, NAMELY, NOTIFYING PARENTS OF A CHANGED STATUS OR CONDITION REGARDING SAFETY VIA EMAIL OR TEXT MESSAGE (U.S. CLS. 100 AND 101).

FIRST USE 5-6-2010; IN COMMERCE 6-9-2010.

CLASS 45—(Continued).

4,017,425. MANDOUR & ASSOCIATES, APC, SAN DIEGO, CA. SN 85-298,095. FILED P.R. 4-18-2011; AM. S.R. 6-20-2011.

IntellectualPropertyNews
.com

NO CLAIM IS MADE TO THE EXCLUSIVE RIGHT TO USE ".COM", APART FROM THE MARK AS SHOWN.

THE MARK CONSISTS OF THE WORDING "INTELLECTUALPROPERTYNEWS" WITH "PROPERTY" APPEARING IN LIGHTER SHADING AND WITH ".COM" ALSO APPEARING IN LIGHTER SHADING BENEATH THE WORD "NEWS".

FOR NEWS REPORTING AND EXPERT LEGAL COMMENTARY SERVICES IN THE FIELD OF LEGAL NEWS (U.S. CLS. 100 AND 101).

FIRST USE 4-14-2011; IN COMMERCE 4-14-2011.

* * * * *

PRIOR UNITED STATES CLASSIFICATION

APPLICATION IN ONE CLASS

CERTIFICATION MARKS

CLASS B—SERVICES

4,017,355. AMERICAN INSTITUTE OF CERTIFIED PUBLIC ACCOUNTANTS, NEW YORK, NY. SN 85-156,015. FILED P.R. 10-19-2010; AM. S.R. 6-7-2011.



OWNER OF U.S. REG. NO. 3,136,126.

NO CLAIM IS MADE TO THE EXCLUSIVE RIGHT TO USE "CPA PFS PERSONAL FINANCIAL SPECIALIST", APART FROM THE MARK AS SHOWN.

THE MARK CONSISTS OF THE LETTERS "CPA" ABOVE A LARGELY HORIZONTAL LINE WHICH, AT THE ENDS OF THE LINE, CURVES TOWARDS OR AROUND THE LETTERS "CPA", ALONG WITH THE LETTERS "PFS" ABOVE THE WORDS "PERSONAL FINANCIAL SPECIALIST".

THE CERTIFICATION MARK, AS USED BY AUTHORIZED PERSONS, BY THE CERTIFIER, CERTIFIES THAT SUCH PERSONS HAVE ACHIEVED COMPETENCE IN COUNSELING INDIVIDUALS ON FINANCIAL PLANNING BY SATISFYING THE CERTIFIER'S RIGID STANDARDS OF TRAINING, CONTINUING EDUCATION, EXAMINATION AND EXPERIENCE IN COUNSELING INDIVIDUALS ON FINANCIAL PLANNING ESTABLISHED BY THE CERTIFIER.

FOR COUNSELING INDIVIDUALS ON FINANCIAL PLANNING (U.S. CL. B).
FIRST USE 5-10-2010; IN COMMERCE 5-10-2010.

* * * * *

TRADEMARK REGISTRATIONS RENEWED

The designation "U.S. Cl." appearing in this section refers to the U.S. class in effect prior to Sep. 1, 1973 rather than the international class which applies to applications filed on or after that date. For adoption of international classification see notice in the OFFICIAL GAZETTE of Jun. 26, 1973 (911 O.G. TM 210).

- | | | | |
|----------|--|----------|--|
| 143,184. | JOHN B. STETSON CO PHILADELPHIA NO. IQUALITY AND DESIGN. U.S. CL. 39. (INT. CL. 25). REG. 5-24-1921. | 720,143. | BOYSCUB BOYS' CLUBS OF AMERICA AND DESIGN. U.S. CL. 200. REG. 8-15-1961. |
| 148,723. | BLACK AND WHITE (STYLIZED). U.S. CL. 6. (INT. CL. 3). REG. 11-22-1921. | 720,513. | TEXIN. INT. CL. 1. (U.S. CL. 1). REG. 8-29-1961. |
| 279,407. | SORBSIL (STYLIZED). U.S. CL. 6. (INT. CL. 1). REG. 1-13-1931. | 721,987. | PLAYMATE. U.S. CL. 38. (INT. CL. 16). REG. 9-26-1961. |
| 281,822. | CERATEX (STYLIZED). U.S. CL. 46. (INT. CL. 30). REG. 3-31-1931. | 723,228. | PARAGON. INT. CL. 1. (U.S. CL. 1). REG. 10-31-1961. |
| 285,893. | MEADOW GOLD (STYLIZED). U.S. CL. 46. (INT. CL. 29). REG. 8-11-1931. | 725,706. | POPOV. U.S. CL. 49. (INT. CL. 33). REG. 12-26-1961. |
| 286,345. | LV AND DESIGN. U.S. CL. 3. (INT. CL. 18). REG. 8-25-1931. | 725,802. | WIRELINK. U.S. CL. 13. (INT. CL. 6). REG. 1-2-1962. |
| 287,744. | MISCELLANEOUS DESIGN. U.S. CL. 28. (INT. CL. 14). REG. 10-6-1931. | 729,648. | AMICAR. U.S. CL. 18. (INT. CL. 5). REG. 4-10-1962. |
| 384,542. | PAGAN (STYLIZED). U.S. CL. 46. (INT. CLS. 1, 5, 29, 30, 31 AND 32). REG. 1-21-1941. | 896,061. | FLIGHT GUIDE (STYLIZED). U.S. CL. 38. (INT. CL. 16). REG. 8-4-1970. |
| 384,876. | CRANELITE. U.S. CL. 34. (INT. CL. 16). REG. 2-4-1941. | 909,892. | SIMICHROME. U.S. CL. 4. (INT. CL. 3). REG. 3-16-1971. |
| 388,227. | WATLOW. U.S. CL. 21. (INT. CL. 11). REG. 6-17-1941. | 910,240. | THE JOINT COMMISSION ON ACCREDITATION OF HOSPITALS. U.S. CL. 100. (INT. CL. 42). REG. 3-16-1971. |
| 390,787. | AMBERLITE. U.S. CL. 6. (INT. CLS. 1, 2, 3, 4 AND 5). REG. 10-7-1941. | 912,021. | PATINAL. U.S. CL. 6. (INT. CL. 1). REG. 6-8-1971. |
| 391,866. | WB WARNER BROS. PICTURES INC. AND DESIGN. U.S. CL. 26. (INT. CL. 9). REG. 11-25-1941. | 912,302. | F-CHEM. U.S. CL. 13. (INT. CL. 17). REG. 6-8-1971. |
| 392,063. | MO-PA-CO. U.S. CL. 16. (INT. CL. 2). REG. 12-9-1941. | 912,540. | ACCU-RIDE. U.S. CL. 19. (INT. CL. 12). REG. 6-8-1971. |
| 394,757. | LECO (STYLIZED). U.S. CL. 26. (INT. CLS. 9 AND 11). REG. 4-28-1942. | 913,257. | PDI (STYLIZED). U.S. CL. 26. (INT. CL. 9). REG. 6-8-1971. |
| 444,537. | MISCELLANEOUS DESIGN. U.S. CL. 49. (INT. CL. 33). REG. 7-31-1951. | 913,294. | UNO-A-ERRE AND DESIGN. U.S. CL. 28. (INT. CL. 14). REG. 6-8-1971. |
| 536,432. | ACROPAK AND DESIGN. U.S. CL. 2. (INT. CLS. 6 AND 7). REG. 1-16-1951. | 913,582. | TREND. U.S. CL. 37. (INT. CL. 16). REG. 6-8-1971. |
| 544,243. | PERNOD (STYLIZED). U.S. CL. 49. (INT. CL. 33). REG. 6-26-1951. | 913,629. | IDEA. U.S. CL. 38. (INT. CL. 16). REG. 6-8-1971. |
| 545,030. | FRENCH'S AND DESIGN. U.S. CL. 46. (INT. CLS. 1, 5, 29, 30, 31 AND 32). REG. 7-17-1951. | 913,632. | MASTERSPEC. U.S. CLS. 38 AND 100. (INT. CLS. 9, 16, 28 AND 42). REG. 6-8-1971. |
| 545,694. | ROCK & DIRT. U.S. CL. 38. (INT. CL. 16). REG. 7-24-1951. | 913,838. | MISCELLANEOUS DESIGN. U.S. CL. 39. (INT. CLS. 10, 25 AND 26). REG. 6-8-1971. |
| 545,912. | FERRO (STYLIZED). INT. CL. 1. (U.S. CL. 1). REG. 7-31-1951. | 914,118. | TAVENERS. U.S. CL. 46. (INT. CL. 30). REG. 6-8-1971. |
| 546,374. | FLAMINGO AND DESIGN. U.S. CL. 39. (INT. CL. 26). REG. 8-7-1951. | 914,134. | MISCELLANEOUS DESIGN. U.S. CL. 46. (INT. CLS. 1, 5, 29, 30, 31 AND 32). REG. 6-8-1971. |
| 547,997. | TOWN AND COUNTRY (STYLIZED). U.S. CL. 19. (INT. CL. 12). REG. 9-11-1951. | 914,752. | MISCELLANEOUS DESIGN. U.S. CL. 105. (INT. CL. 39). REG. 6-8-1971. |
| 548,372. | PERMOPLAST. U.S. CL. 1. (INT. CL. 16). REG. 9-18-1951. | 914,774. | PINE LAKES COUNTRY CLUB CPLC AND DESIGN. U.S. CL. 107. (INT. CL. 41). REG. 6-8-1971. |
| 549,898. | GATES AND DESIGN. U.S. CL. 35. (INT. CLS. 7, 12 AND 17). REG. 10-23-1951. | 915,264. | NORTHAMERICAN VANLINES AND DESIGN. U.S. CL. 105. (INT. CL. 39). REG. 6-15-1971. |
| 551,057. | BRIDE'S PRIDE. U.S. CL. 28. (INT. CL. 14). REG. 11-20-1951. | 916,118. | CEROL. U.S. CL. 6. (INT. CL. 1). REG. 7-13-1971. |
| 558,416. | VESTBAK (STYLIZED). U.S. CL. 39. (INT. CLS. 10, 25 AND 26). REG. 5-6-1952. | 917,508. | QUAD. U.S. CL. 13. (INT. CLS. 7 AND 17). REG. 8-3-1971. |
| 716,317. | SPECTRACIDE. U.S. CL. 6. (INT. CL. 5). REG. 6-6-1961. | 917,624. | HYDRO-SLAVE. U.S. CL. 23. (INT. CL. 7). REG. 8-3-1971. |
| 716,795. | E-Z-FOLD. U.S. CL. 22. (INT. CL. 28). REG. 6-13-1961. | 917,924. | TRIMANOX. U.S. CL. 1. (INT. CL. 6). REG. 8-10-1971. |
| 717,121. | PROTOPAM. U.S. CL. 18. (INT. CL. 5). REG. 6-20-1961. | 920,338. | PROJECTS UNLIMITED AND DESIGN. U.S. CL. 100. (INT. CL. 42). REG. 9-14-1971. |
| 717,273. | TWINKIES. U.S. CL. 46. (INT. CL. 30). REG. 6-20-1961. | 920,822. | DEVONSHEER. U.S. CL. 46. (INT. CLS. 1, 5, 29, 30, 31 AND 32). REG. 9-21-1971. |
| 717,485. | MOTOROLA. U.S. CL. 21. (INT. CLS. 7, 9, 11, 12 AND 15). REG. 6-27-1961. | 920,855. | ND-66. U.S. CL. 52. (INT. CL. 3). REG. 9-21-1971. |
| 718,276. | SPEEDO. U.S. CL. 39. (INT. CL. 25). REG. 7-11-1961. | 921,093. | REDFIELD. U.S. CL. 26. (INT. CLS. 1, 9 AND 10). REG. 9-28-1971. |
| 718,394. | LUTONAL. INT. CL. 1. (U.S. CL. 1). REG. 7-18-1961. | 921,163. | WHO'S WHO INTERNATIONAL IN THE EGG ANDPOULTRY INDUSTRIES (STYLIZED). U.S. CL. 38. (INT. CL. 16). REG. 9-28-1971. |
| 718,553. | M AND DESIGN. U.S. CL. 31. (INT. CL. 11). REG. 7-18-1961. | 922,820. | QUAD. U.S. CL. 36. (INT. CL. 9). REG. 10-26-1971. |
| | | 923,337. | PENGUIN POINT. U.S. CL. 100. (INT. CL. 42). REG. 11-2-1971. |
| | | 924,538. | NO PAC. U.S. CL. 1. (INT. CL. 31). REG. 11-30-1971. |
| | | 924,925. | KOHJIN-KORAP. U.S. CL. 1. (INT. CL. 17). REG. 12-7-1971. |

925,209.	SURVIVA. U.S. CL. 46. (INT. CL. 30). REG. 12-7-1971.	1,164,174.	HOMER'S. INT. CL. 42. (U.S. CL. 101). REG. 8-4-1981.
925,372.	CAMFLEX. U.S. CL. 13. (INT. CL. 6). REG. 12-14-1971.	1,164,199.	SAFE T DOOR AND DESIGN. INT. CL. 6. (U.S. CLS. 12 AND 32). REG. 8-4-1981.
929,575.	UNIQUE. U.S. CL. 34. (INT. CL. 11). REG. 2-22-1972.	1,166,122.	CONTROX. INT. CL. 7. (U.S. CL. 23). REG. 8-25-1981.
929,775.	EL CHICO. U.S. CL. 101. (INT. CL. 35). REG. 2-22-1972.	1,166,327.	3M (STYLIZED). INT. CL. 9. (U.S. CL. 21). REG. 8-25-1981.
1,146,243.	SHAZAM! (STYLIZED). INT. CL. 28. (U.S. CL. 22). REG. 1-20-1981.	1,166,616.	TOUR MASTER AND DESIGN. INT. CL. 25. (U.S. CL. 39). REG. 8-25-1981.
1,152,886.	AMDRIY. INT. CL. 6. (U.S. CLS. 2, 12, 13, 14, 23, 25 AND 50). REG. 5-5-1981.	1,168,724.	BAJA 1000. INT. CL. 41. (U.S. CL. 107). REG. 9-8-1981.
1,152,948.	SLO-ROL. INT. CL. 9. (U.S. CL. 26). REG. 5-5-1981.	1,169,742.	PG AND DESIGN. U.S. CL. B. REG. 9-15-1981.
1,153,421.	LPPS. INT. CL. 42 ONLY. (U.S. CL. 100). REG. 5-5-1981.	1,169,743.	G AND DESIGN. U.S. CL. B. REG. 9-15-1981.
1,154,522.	GEMATIC. INT. CL. 6. (U.S. CL. 25). REG. 5-19-1981.	1,171,267.	CLASSIC. INT. CL. 19. (U.S. CL. 12). REG. 9-29-1981.
1,154,580.	P (STYLIZED). INT. CLS. 9 AND 12 ONLY. (U.S. CLS. 19, 21, 23, 26, 31, 35, 36, 38 AND 44). REG. 5-19-1981.	1,172,015.	HYCORR. INT. CL. 7. (U.S. CLS. 13, 19, 21, 23, 31, 34 AND 35). REG. 10-6-1981.
1,154,616.	TITAN TOOLS AND DESIGN. INT. CL. 8. (U.S. CLS. 13 AND 23). REG. 5-19-1981.	1,172,079.	POLYBONDEX. INT. CL. 9. (U.S. CL. 21). REG. 10-6-1981.
1,154,964.	THE LAST DROP FROM HIS STETSON AND DESIGN. INT. CL. 26. (U.S. CL. 40). REG. 5-19-1981.	1,172,665.	DUNHILL. INT. CL. 42. (U.S. CLS. 100 AND 101). REG. 10-6-1981.
1,155,014.	CK AND DESIGN. INT. CL. 31. (U.S. CL. 46). REG. 5-19-1981.	1,173,275.	HOWE. INT. CL. 20. (U.S. CL. 32). REG. 10-13-1981.
1,155,313.	LAROX. INT. CL. 7. (U.S. CL. 23). REG. 5-26-1981.	1,173,666.	THE PATHWORK. INT. CL. 41. (U.S. CLS. 100, 101 AND 107). REG. 10-13-1981.
1,156,585.	SNAPPLE. INT. CL. 32. (U.S. CL. 46). REG. 6-2-1981.	1,174,173.	GRIP-SEAL. INT. CL. 16. (U.S. CL. 37). REG. 10-20-1981.
1,157,296.	BINNEY & SMITH AND DESIGN. INT. CL. 16. (U.S. CL. 1). REG. 6-9-1981.	1,174,680.	MEL-1. INT. CL. 1. (U.S. CL. 6). REG. 10-27-1981.
1,157,326.	ALL AMERICAN. INT. CL. 20. (U.S. CL. 50). REG. 6-9-1981.	1,178,379.	HENDERSON'S BEST (STYLIZED). INT. CLS. 31 AND 32. (U.S. CL. 46). REG. 11-17-1981.
1,157,499.	POPIN PEANUT BUNCH. INT. CL. 30. (U.S. CL. 46). REG. 6-9-1981.	1,178,396.	BLUEBONNET. INT. CL. 31. (U.S. CL. 46). REG. 11-17-1981.
1,158,526.	CATFISH PARLOUR. INT. CL. 42. (U.S. CL. 100). REG. 6-23-1981.	1,179,704.	VITAL CARE. INT. CL. 3. (U.S. CLS. 51 AND 52). REG. 12-1-1981.
1,158,563.	FUN BUNCH LUNCH. INT. CL. 42. (U.S. CL. 100). REG. 6-23-1981.	1,181,713.	MICARES. INT. CL. 1. (U.S. CL. 1). REG. 12-15-1981.
1,158,767.	ESPE. INT. CLS. 5 AND 10. (U.S. CL. 44). REG. 6-30-1981.	1,182,505.	CASPERS. INT. CL. 42. (U.S. CL. 100). REG. 12-15-1981.
1,159,436.	LEE MYLES TRANSMISSIONS AND DESIGN. INT. CL. 37. (U.S. CL. 103). REG. 6-30-1981.	1,184,784.	DUROMAR. INT. CL. 19. (U.S. CL. 12). REG. 1-5-1982.
1,159,454.	VOLVO (STYLIZED). INT. CL. 39. (U.S. CL. 105). REG. 6-30-1981.	1,188,770.	"SNICKERDOODLE". INT. CL. 28. (U.S. CL. 22). REG. 2-2-1982.
1,159,562.	FISH TALE AND DESIGN. INT. CL. 42. (U.S. CL. 100). REG. 6-30-1981.	1,188,771.	"SNICKERDOODLE'S PEANUTMOBILE". INT. CL. 28. (U.S. CL. 22). REG. 2-2-1982.
1,159,604.	FLEMION. INT. CL. 1. (U.S. CL. 1). REG. 7-7-1981.	1,189,727.	WALT DISNEY WORLD. INT. CLS. 6, 16, 21, 41 AND 42 ONLY. (U.S. CLS. 2, 5, 12, 13, 14, 22, 23, 25, 29, 30, 33, 37, 38, 40, 50, 100, 101 AND 107). REG. 2-16-1982.
1,159,634.	MAKING LOVE. INT. CL. 3. (U.S. CLS. 6 AND 51). REG. 7-7-1981.	1,193,936.	MISCELLANEOUS DESIGN. INT. CL. 12. (U.S. CL. 19). REG. 4-20-1982.
1,159,680.	PNEUMAFIL. INT. CL. 6. (U.S. CL. 2). REG. 7-7-1981.	1,194,663.	TWO STRIPER. INT. CL. 10. (U.S. CL. 44). REG. 5-4-1982.
1,159,693.	"BLOCKS THE SUN, NOT THE VIEW". INT. CL. 6. (U.S. CL. 12). REG. 7-7-1981.	1,195,309.	JAXON. INT. CL. 30. (U.S. CL. 46). REG. 5-11-1982.
1,160,119.	MASERATI. INT. CL. 25. (U.S. CL. 39). REG. 7-7-1981.	1,198,178.	GRAPE VALLEY. INT. CL. 31. (U.S. CL. 46). REG. 6-15-1982.
1,160,201.	CVI. INT. CL. 31. (U.S. CL. 1). REG. 7-7-1981.	1,200,085.	EXPEDITER. INT. CL. 3. (U.S. CLS. 4 AND 52). REG. 7-6-1982.
1,160,355.	MYSTIC SEAPORT MUSEUM. INT. CLS. 41 AND 42. (U.S. CLS. 101 AND 107). REG. 7-7-1981.	1,318,331.	R (STYLIZED). INT. CL. 28. (U.S. CLS. 22, 23, 38 AND 50). REG. 2-5-1985.
1,160,402.	MR. CHOW. INT. CL. 42. (U.S. CLS. 100 AND 101). REG. 7-7-1981.	1,427,897.	COLBY RIDGE. INT. CL. 42. (U.S. CL. 100). REG. 2-3-1987.
1,160,481.	GIORDANO'S AND DESIGN. INT. CL. 42. (U.S. CL. 100). REG. 7-7-1981.	1,481,262.	EQUICARE AND DESIGN. INT. CLS. 3 AND 5. (U.S. CLS. 6, 18, 51 AND 52). REG. 3-22-1988.
1,160,492.	COLOMBIAN. U.S. CL. A. REG. 7-7-1981.	1,606,840.	LEARNING SOLUTIONS. INT. CL. 42. (U.S. CLS. 100 AND 101). REG. 7-17-1990.
1,160,700.	EXAKTA. INT. CL. 9. (U.S. CL. 26). REG. 7-14-1981.	1,609,550.	CONCEPTROL. INT. CL. 5. (U.S. CL. 18). REG. 8-14-1990.
1,160,790.	PANAVISION. INT. CL. 9. (U.S. CL. 26). REG. 7-14-1981.	1,618,340.	TERRY JACOBS COSMETICS FOR THE TROPICS AND DESIGN. INT. CL. 3. (U.S. CL. 51). REG. 10-23-1990.
1,161,031.	MISCELLANEOUS DESIGN. INT. CL. 25. (U.S. CLS. 22 AND 39). REG. 7-14-1981.	1,621,182.	RIP-STRIP. INT. CL. 16. (U.S. CL. 37). REG. 11-6-1990.
1,161,375.	CARDINALS SL AND DESIGN. INT. CL. 41. (U.S. CL. 107). REG. 7-14-1981.	1,623,443.	ACISS. INT. CL. 9. (U.S. CL. 38). REG. 11-20-1990.
1,161,887.	BARRIER-MET. INT. CL. 16. (U.S. CL. 37). REG. 7-21-1981.	1,624,080.	BRITISH AIRWAYS HOLIDAYS. INT. CL. 39. (U.S. CL. 105). REG. 11-20-1990.
1,161,981.	FREEDOM. INT. CL. 21. (U.S. CL. 2). REG. 7-21-1981.	1,625,660.	BUDDY SYSTEM. INT. CL. 8. (U.S. CL. 23). REG. 12-4-1990.
1,163,417.	ARO AND DESIGN. INT. CL. 7. (U.S. CL. 34). REG. 8-4-1981.	1,625,960.	STANDPAK. INT. CL. 16. (U.S. CL. 2). REG. 12-4-1990.
1,163,697.	JOURNAL OF THE AMERICAN OIL CHEMISTS' SOCIETY (STYLIZED). INT. CL. 16. (U.S. CL. 38). REG. 8-4-1981.	1,627,099.	PURSE 'N POCKET. INT. CL. 16. (U.S. CL. 37). REG. 12-11-1990.
1,163,721.	BINNEY & SMITH AND DESIGN. INT. CL. 16. (U.S. CL. 37). REG. 8-4-1981.	1,630,658.	POCKET MEMO. INT. CL. 9. (U.S. CL. 21). REG. 1-8-1991.

- 1,631,391. CALYPSO AND DESIGN. INT. CLS. 9, 14, 16, 25, 28 AND 42. (U.S. CLS. 21, 22, 28, 37, 38, 39 AND 101). REG. 1-15-1991.
- 1,631,612. K-STIC. INT. CL. 17. (U.S. CL. 5). REG. 1-15-1991.
- 1,631,620. PERTTI PALMROTH. INT. CLS. 18 AND 25. (U.S. CLS. 3 AND 39). REG. 1-15-1991.
- 1,631,985. AGGREKO. INT. CL. 42. (U.S. CL. 100). REG. 1-15-1991.
- 1,632,162. DOUGHPRO. INT. CL. 7. (U.S. CL. 23). REG. 1-22-1991.
- 1,632,929. AGGREKO. INT. CL. 7. (U.S. CLS. 21 AND 23). REG. 1-29-1991.
- 1,635,189. PEDS PLUS (STYLIZED). INT. CL. 1. (U.S. CL. 6). REG. 2-19-1991.
- 1,641,044. TR (STYLIZED). INT. CL. 7. (U.S. CL. 23). REG. 4-16-1991.
- 1,644,518. OCEAN GOLD. INT. CL. 29. (U.S. CL. 46). REG. 5-14-1991.
- 1,644,915. VIREX 128. INT. CL. 5. (U.S. CL. 6). REG. 5-21-1991.
- 1,645,805. TROY-BILT (STYLIZED). INT. CL. 7. (U.S. CLS. 13, 19, 21, 23, 31, 34 AND 35). REG. 5-28-1991.
- 1,646,463. ADVENTURE BY JEAN PHILIPPE. INT. CL. 3. (U.S. CL. 51). REG. 5-28-1991.
- 1,646,540. AIRGAS. INT. CLS. 1 AND 5. (U.S. CLS. 6 AND 18). REG. 6-4-1991.
- 1,646,734. LIQUI-CEL. INT. CL. 9. (U.S. CLS. 21 AND 26). REG. 6-4-1991.
- 1,646,742. PATHDATA. INT. CL. 9. (U.S. CL. 38). REG. 6-4-1991.
- 1,646,771. DOBERMANN. INT. CL. 12. (U.S. CL. 35). REG. 6-4-1991.
- 1,647,093. MORTON'S OF CHICAGO. INT. CL. 42. (U.S. CL. 100). REG. 6-4-1991.
- 1,647,117. LIFE. INT. CL. 42. (U.S. CL. 101). REG. 6-4-1991.
- 1,647,134. QIK JOE AND DESIGN. INT. CLS. 1, 3 AND 4. (U.S. CLS. 1, 6 AND 51). REG. 6-11-1991.
- 1,647,365. MICRO-KLEAN (STYLIZED). INT. CL. 11. (U.S. CL. 31). REG. 6-11-1991.
- 1,647,537. CANDIA. INT. CL. 29. (U.S. CL. 46). REG. 6-11-1991.
- 1,647,578. LG AND DESIGN. INT. CL. 31. (U.S. CL. 1). REG. 6-11-1991.
- 1,647,606. CALABAR AND DESIGN. INT. CL. 34. (U.S. CL. 17). REG. 6-11-1991.
- 1,647,612. MISCELLANEOUS DESIGN. INT. CL. 34. (U.S. CL. 17). REG. 6-11-1991.
- 1,647,779. REPOEDGE. INT. CL. 42. (U.S. CLS. 100 AND 101). REG. 6-11-1991.
- 1,648,023. SOUND BARRIER. INT. CL. 9. (U.S. CLS. 21 AND 36). REG. 6-18-1991.
- 1,648,038. EQUIMETER. INT. CL. 9. (U.S. CLS. 21 AND 26). REG. 6-18-1991.
- 1,648,117. BUILDING DESIGN & CONSTRUCTION. INT. CL. 16. (U.S. CL. 38). REG. 6-18-1991.
- 1,648,159. FORMICA. INT. CL. 17. (U.S. CLS. 1 AND 12). REG. 6-18-1991.
- 1,648,265. FAKIN' BACON. INT. CL. 29. (U.S. CL. 46). REG. 6-18-1991.
- 1,648,547. WOLFFTRAP. INT. CL. 25. (U.S. CL. 39). REG. 6-18-1991.
- 1,648,817. COLLINS. INT. CL. 16. (U.S. CL. 38). REG. 6-25-1991.
- 1,648,895. ANGELS FLIGHT. INT. CL. 25. (U.S. CLS. 22 AND 39). REG. 6-25-1991.
- 1,649,013. BCOAA BLACK COLLEGES OF AMERICA ALUMNI. INT. CL. 36. (U.S. CLS. 100 AND 102). REG. 6-25-1991.
- 1,649,027. DD AND DESIGN. INT. CL. 37. (U.S. CL. 103). REG. 6-25-1991.
- 1,649,208. SEANAMINE. INT. CL. 1. (U.S. CL. 6). REG. 7-2-1991.
- 1,649,437. MISCELLANEOUS DESIGN. INT. CLS. 16 AND 41. (U.S. CLS. 38 AND 107). REG. 7-2-1991.
- 1,649,605. PARROT AND DESIGN. INT. CL. 29. (U.S. CL. 46). REG. 7-2-1991.
- 1,650,036. EQUIMETER AND DESIGN. INT. CL. 9. (U.S. CLS. 21 AND 26). REG. 7-9-1991.
- 1,650,596. MISCELLANEOUS DESIGN. INT. CLS. 9, 11, 14, 18 AND 21 ONLY. (U.S. CLS. 1, 2, 3, 13, 21, 22, 23, 26, 27, 28, 29, 30, 31, 33, 34, 36, 38, 40, 41 AND 50). REG. 7-16-1991.
- 1,650,626. BRF (STYLIZED). INT. CLS. 9 AND 21. (U.S. CLS. 2, 26 AND 33). REG. 7-16-1991.
- 1,650,800. AQUIS. INT. CL. 24. (U.S. CL. 42). REG. 7-16-1991.
- 1,650,826. EMILIO FRANCO. INT. CL. 25. (U.S. CL. 39). REG. 7-16-1991.
- 1,650,957. MISCELLANEOUS DESIGN. INT. CL. 31. (U.S. CL. 1). REG. 7-16-1991.
- 1,651,009. SIMPLICITY. INT. CL. 36. (U.S. CLS. 101 AND 102). REG. 7-16-1991.
- 1,651,184. THE PIN TRADER. INT. CL. 18. (U.S. CL. 3). REG. 7-16-1991.
- 1,651,315. EASY WAGON/EASY CART/BICYCLE WHEEL BRACKETS. INT. CL. 6 ONLY. (U.S. CL. 13). REG. 7-23-1991.
- 1,651,339. DE-STONER. INT. CL. 7. (U.S. CLS. 23 AND 26). REG. 7-23-1991.
- 1,651,752. DELPHI. INT. CL. 41. (U.S. CLS. 100, 101 AND 107). REG. 7-23-1991.
- 1,651,983. EVERBAKE. INT. CL. 29. (U.S. CL. 46). REG. 7-23-1991.
- 1,652,070. MULTIPLE LISTING NETWORK. INT. CL. 36. (U.S. CLS. 101 AND 102). REG. 7-23-1991.
- 1,652,305. PURESTREAM INCORPORATED AND DESIGN. INT. CL. 11. (U.S. CLS. 13 AND 31). REG. 7-30-1991.
- 1,652,332. EVANS. INT. CL. 15. (U.S. CL. 36). REG. 7-30-1991.
- 1,652,538. DELICIOUS ANYTIME!. INT. CL. 30. (U.S. CL. 46). REG. 7-30-1991.
- 1,654,202. S (STYLIZED). INT. CL. 9 ONLY. (U.S. CLS. 21, 23, 26, 36 AND 38). REG. 8-20-1991.
- 1,654,302. TORRASPEL AND DESIGN. INT. CL. 16. (U.S. CLS. 2, 5, 22, 23, 29, 37, 38 AND 50). REG. 8-20-1991.
- 1,654,311. WIND RIVER STUDIOS AND DESIGN. INT. CL. 16. (U.S. CL. 38). REG. 8-20-1991.
- 1,654,504. VIRTUAL TECHNOLOGY, INC.. INT. CLS. 37 AND 42. (U.S. CLS. 100, 101 AND 103). REG. 8-20-1991.
- 1,656,117. BETMATE. INT. CL. 9. (U.S. CL. 26). REG. 9-10-1991.
- 1,656,412. JAMESON. INT. CL. 33. (U.S. CLS. 47 AND 49). REG. 9-10-1991.
- 1,656,465. SPELMAN COLLEGE. INT. CL. 41. (U.S. CLS. 100, 101 AND 107). REG. 9-10-1991.
- 1,656,869. GUMLITE. INT. CL. 25. (U.S. CL. 39). REG. 9-10-1991.
- 1,657,461. SPENCER'S. INT. CLS. 24 AND 25. (U.S. CLS. 22, 39, 42 AND 50). REG. 9-17-1991.
- 1,658,581. WILDLIFE FOREVER AND DESIGN. INT. CL. 42. (U.S. CL. 100). REG. 9-24-1991.
- 1,658,723. DUECO. INT. CL. 37. (U.S. CL. 103). REG. 9-24-1991.
- 1,659,447. NAIL EATER. INT. CL. 7. (U.S. CL. 23). REG. 10-8-1991.
- 1,660,089. GOETTL AIR CONDITIONING AND DESIGN. INT. CL. 37. (U.S. CL. 103). REG. 10-8-1991.
- 1,660,186. ECKLER'S. INT. CL. 42. (U.S. CL. 101). REG. 10-8-1991.
- 1,660,548. GENESIS. INT. CL. 9. (U.S. CL. 26). REG. 10-15-1991.
- 1,661,282. LACTOMER. INT. CL. 10. (U.S. CL. 44). REG. 10-15-1991.
- 1,661,650. GIANTS. INT. CLS. 16 AND 25. (U.S. CLS. 2, 5, 22, 23, 29, 37, 38, 39 AND 50). REG. 10-22-1991.
- 1,661,782. ZERO. INT. CL. 25 ONLY. (U.S. CL. 39). REG. 10-22-1991.
- 1,661,862. SOUTHERN STACK. INT. CL. 30. (U.S. CL. 46). REG. 10-22-1991.
- 1,662,555. ARBOR WAY. INT. CL. 25. (U.S. CL. 39). REG. 10-29-1991.
- 1,664,340. YANKELOVICH MONITOR. INT. CL. 35. (U.S. CLS. 100 AND 101). REG. 11-12-1991.
- 1,664,721. EXONEL. INT. CL. 7. (U.S. CL. 23). REG. 11-19-1991.
- 1,666,000. G GENERAL MILLS (STYLIZED). INT. CL. 30. (U.S. CL. 46). REG. 11-26-1991.
- 1,666,192. EL NOVILLO RESTAURANT AND DESIGN. INT. CL. 42. (U.S. CL. 100). REG. 11-26-1991.
- 1,669,910. SQUEEZERS. INT. CL. 29. (U.S. CL. 46). REG. 12-24-1991.
- 1,669,986. CIRCuset. INT. CL. 2. (U.S. CLS. 6 AND 11). REG. 12-31-1991.
- 1,671,020. PEEL-A-WAY. INT. CL. 9. (U.S. CL. 21). REG. 1-7-1992.
- 1,673,938. RNASE COCKTAIL. INT. CL. 1. (U.S. CLS. 1 AND 6). REG. 2-4-1992.
- 1,674,390. LAMKIN (STYLIZED). INT. CL. 28. (U.S. CL. 22). REG. 2-4-1992.

- 1,674,489. SMALLCAP WORLD FUND. INT. CL. 36. (U.S. CL. 102). REG. 2-4-1992.
- 1,676,275. MISCELLANEOUS DESIGN. INT. CL. 42. (U.S. CLS. 101 AND 107). REG. 2-18-1992.
- 1,676,779. WMP. INT. CL. 17. (U.S. CLS. 1 AND 35). REG. 2-25-1992.
- 1,677,266. TEC/PRIME. INT. CL. 2. (U.S. CL. 16). REG. 3-3-1992.
- 1,680,423. TASK FORCE. INT. CL. 21. (U.S. CL. 29). REG. 3-24-1992.
- 1,680,597. W THE WOLSTEIN GROUP (STYLIZED). INT. CL. 37. (U.S. CL. 103). REG. 3-24-1992.
- 1,682,115. SCIMITAR. INT. CL. 28. (U.S. CL. 22). REG. 4-7-1992.
- 1,682,371. NSX. INT. CL. 12. (U.S. CLS. 19, 21, 23, 31, 35 AND 44). REG. 4-7-1992.
- 1,682,413. ALEX EVENINGS. INT. CL. 25. (U.S. CL. 39). REG. 4-7-1992.
- 1,683,476. PAT O'BRIEN'S HURRICANE. INT. CL. 33. (U.S. CL. 49). REG. 4-14-1992.
- 1,683,645. VOLK AREA CENTRALIS. INT. CL. 9. (U.S. CL. 26). REG. 4-21-1992.
- 1,685,449. SMART FLOAT. INT. CL. 28. (U.S. CLS. 22, 23, 38 AND 50). REG. 5-5-1992.
- 1,687,153. DUR-A-EDGE. INT. CL. 20. (U.S. CL. 32). REG. 5-12-1992.
- 1,687,867. SONGS TO READ. INT. CL. 16. (U.S. CL. 38). REG. 5-19-1992.
- 1,688,259. PHI DELTA PHI. U.S. CL. 200. REG. 5-19-1992.
- 1,689,073. ULTRA COURT. INT. CL. 20. (U.S. CL. 32). REG. 5-26-1992.
- 1,689,076. COLOR COURT. INT. CL. 20. (U.S. CL. 32). REG. 5-26-1992.
- 1,689,378. STEWART COLLECTION. INT. CL. 41. (U.S. CLS. 100, 101, 106 AND 107). REG. 5-26-1992.
- 1,689,848. A AND DESIGN. INT. CL. 7. (U.S. CL. 23). REG. 6-2-1992.
- 1,689,972. PRIME IMAGE. INT. CL. 9. (U.S. CL. 21). REG. 6-2-1992.
- 1,690,138. COLLIER ON BANKRUPTCY. INT. CL. 16. (U.S. CL. 38). REG. 6-2-1992.
- 1,690,255. MANITOU AND COG WHEEL ROUTE PIKE'S PEAKRAILWAY AND DESIGN. INT. CL. 25. (U.S. CL. 39). REG. 6-2-1992.
- 1,690,704. NUTRA BETIC. INT. CL. 5. (U.S. CL. 18). REG. 6-2-1992.
- 1,693,226. CORIOLIS. INT. CL. 28. (U.S. CL. 22). REG. 6-9-1992.
- 1,694,342. TECHNOWIPE. INT. CL. 16. (U.S. CL. 37). REG. 6-16-1992.
- 1,696,173. TECATE. INT. CL. 25. (U.S. CL. 39). REG. 6-23-1992.
- 1,697,269. MIRADRI. INT. CL. 1. (U.S. CL. 6). REG. 6-30-1992.
- 1,699,371. DOVEX. INT. CL. 35. (U.S. CL. 101). REG. 7-7-1992.
- 1,699,970. DOUBLETREE CLUB HOTEL. INT. CL. 42. (U.S. CL. 100). REG. 7-7-1992.
- 2,050,084. MISCELLANEOUS DESIGN. INT. CL. 9. (U.S. CL. 26). REG. 4-8-1997.
- 2,384,067. COPILOT. INT. CL. 10. (U.S. CLS. 26, 39 AND 44). REG. 9-5-2000.
- 2,390,275. POWERSHIELD. INT. CL. 10. (U.S. CLS. 26, 39 AND 44). REG. 9-26-2000.
- 2,395,824. BABY'S TIME CAPSULE. INT. CL. 6. (U.S. CLS. 2, 12, 13, 14, 23, 25 AND 50). REG. 10-17-2000.
- 2,405,943. COMTRONIC. INT. CLS. 7 AND 9. (U.S. CLS. 13, 19, 21, 23, 26, 31, 34, 35, 36 AND 38). REG. 11-21-2000.
- 2,407,059. 1-800 NO SWEAT. INT. CLS. 35 AND 37. (U.S. CLS. 100, 101, 102, 103 AND 106). REG. 11-21-2000.
- 2,407,553. THE ULTIMATE BAND LIST. INT. CLS. 35 AND 41. (U.S. CLS. 100, 101, 102 AND 107). REG. 11-28-2000.
- 2,410,277. INNOVATION MASTERS. INT. CL. 41. (U.S. CLS. 100, 101 AND 107). REG. 12-5-2000.
- 2,410,914. ALTERNA. INT. CL. 3. (U.S. CLS. 1, 4, 6, 50, 51 AND 52). REG. 12-5-2000.
- 2,411,357. HOMZ. INT. CL. 21. (U.S. CLS. 2, 13, 23, 29, 30, 33, 40 AND 50). REG. 12-5-2000.
- 2,417,406. COLLECTIVE INTELLECT. INT. CL. 42. (U.S. CLS. 100 AND 101). REG. 1-2-2001.
- 2,418,016. INTELLIGENT BIOCIDES. INT. CL. 1. (U.S. CLS. 1, 5, 6, 10, 26 AND 46). REG. 1-2-2001.
- 2,419,597. ORCA. INT. CL. 9. (U.S. CLS. 21, 23, 26, 36 AND 38). REG. 1-9-2001.
- 2,420,356. MISCELLANEOUS DESIGN. INT. CL. 9. (U.S. CLS. 21, 23, 26, 36 AND 38). REG. 1-16-2001.
- 2,420,751. SOF-TOUCH. INT. CL. 7. (U.S. CLS. 13, 19, 21, 23, 31, 34 AND 35). REG. 1-16-2001.
- 2,420,770. WILD BY NATURE. INT. CL. 16. (U.S. CLS. 2, 5, 22, 23, 29, 37, 38 AND 50). REG. 1-16-2001.
- 2,421,087. PERFORMANCE. INT. CL. 35. (U.S. CLS. 100, 101 AND 102). REG. 1-16-2001.
- 2,421,089. PERFORMANCE BICYCLE. INT. CL. 35. (U.S. CLS. 100, 101 AND 102). REG. 1-16-2001.
- 2,421,169. AUDUBON QUARTET. INT. CL. 41. (U.S. CLS. 100, 101 AND 107). REG. 1-16-2001.
- 2,421,219. FUELING TACTICS. INT. CL. 42. (U.S. CLS. 100 AND 101). REG. 1-16-2001.
- 2,421,220. SOFTAL PROCESS. INT. CL. 25. (U.S. CLS. 22 AND 39). REG. 1-16-2001.
- 2,421,713. SNAP SERVER. INT. CL. 9. (U.S. CLS. 21, 23, 26, 36 AND 38). REG. 1-16-2001.
- 2,422,175. HYPERVIEW PLAYER. INT. CL. 9. (U.S. CLS. 21, 23, 26, 36 AND 38). REG. 1-16-2001.
- 2,422,227. MISCELLANEOUS DESIGN. INT. CL. 40. (U.S. CLS. 100, 103 AND 106). REG. 1-16-2001.
- 2,422,277. CHURCH DEVELOPMENT FUND. INT. CL. 36. (U.S. CLS. 100, 101 AND 102). REG. 1-16-2001.
- 2,423,006. NEMESIS. INT. CL. 9. (U.S. CLS. 21, 23, 26, 36 AND 38). REG. 1-23-2001.
- 2,423,582. IDEA. INT. CL. 9. (U.S. CLS. 21, 23, 26, 36 AND 38). REG. 1-23-2001.
- 2,425,143. CENTRICUT. INT. CL. 7. (U.S. CLS. 13, 19, 21, 23, 31, 34 AND 35). REG. 1-30-2001.
- 2,427,751. COMPUTER BILD AND DESIGN. INT. CLS. 16 AND 42 ONLY. (U.S. CLS. 2, 5, 22, 23, 29, 37, 38, 50, 100 AND 101). REG. 2-13-2001.
- 2,427,828. WILDFRUIT. INT. CL. 29. (U.S. CL. 46). REG. 2-13-2001.
- 2,432,483. REAL DEAL. INT. CL. 42. (U.S. CLS. 100 AND 101). REG. 3-6-2001.
- 2,434,130. TRIMARAN. INT. CL. 36. (U.S. CLS. 100, 101 AND 102). REG. 3-6-2001.
- 2,434,782. MISCELLANEOUS DESIGN. INT. CL. 36 ONLY. (U.S. CLS. 100, 101 AND 102). REG. 3-13-2001.
- 2,435,287. MYCATTLE.COM. INT. CL. 42. (U.S. CLS. 100 AND 101). REG. 3-13-2001.
- 2,436,270. ECG. INT. CL. 9. (U.S. CLS. 21, 23, 26, 36 AND 38). REG. 3-20-2001.
- 2,439,569. IMAGEMOVERS AND DESIGN. INT. CL. 41. (U.S. CLS. 100, 101 AND 107). REG. 3-27-2001.
- 2,440,739. STUDENTCITY. INT. CL. 39. (U.S. CLS. 100 AND 105). REG. 4-3-2001.
- 2,441,920. AMERICAN FUNDS INSURANCE SERIES. INT. CL. 36. (U.S. CLS. 100, 101 AND 102). REG. 4-10-2001.
- 2,442,020. CREATIVE PERSPECTIVES. INT. CLS. 35 AND 42. (U.S. CLS. 100, 101 AND 102). REG. 4-10-2001.
- 2,442,135. FELLOWES AND DESIGN. INT. CLS. 3, 9, 16 AND 20 ONLY. (U.S. CLS. 1, 2, 4, 5, 6, 13, 21, 22, 23, 25, 26, 29, 32, 36, 37, 38, 50, 51 AND 52). REG. 4-10-2001.
- 2,443,277. GABATEIN. INT. CL. 5. (U.S. CLS. 6, 18, 44, 46, 51 AND 52). REG. 4-10-2001.
- 2,443,950. CAMBER. INT. CL. 15. (U.S. CLS. 2, 21 AND 36). REG. 4-17-2001.
- 2,445,376. TRADE BYTES. INT. CLS. 9 AND 35. (U.S. CLS. 21, 23, 26, 36, 38, 100, 101 AND 102). REG. 4-24-2001.
- 2,445,838. RIVETING MEDIA. INT. CL. 42. (U.S. CLS. 100 AND 101). REG. 4-24-2001.
- 2,447,329. AMARETTA. INT. CLS. 18, 20 AND 28 ONLY. (U.S. CLS. 1, 2, 3, 13, 22, 23, 25, 32, 38, 41 AND 50). REG. 5-1-2001.
- 2,447,925. 1-800-GO-HYATT. INT. CL. 36. (U.S. CLS. 100, 101 AND 102). REG. 5-1-2001.
- 2,449,997. TOYOTOMI AMERICA. INT. CL. 40. (U.S. CLS. 100, 103 AND 106). REG. 5-8-2001.
- 2,450,195. RUSSLOCK. INT. CL. 8. (U.S. CLS. 23, 28 AND 44). REG. 5-8-2001.
- 2,453,172. MUSIC MIDTOWN. INT. CL. 41. (U.S. CLS. 100, 101 AND 107). REG. 5-22-2001.
- 2,455,193. C-RAM IT. INT. CL. 1. (U.S. CLS. 1, 5, 6, 10, 26 AND 46). REG. 5-29-2001.
- 2,455,348. STRAP JACK. INT. CL. 7. (U.S. CLS. 13, 19, 21, 23, 31, 34 AND 35). REG. 5-29-2001.
- 2,455,385. FASTOCK. INT. CL. 35. (U.S. CLS. 100, 101 AND 102). REG. 5-29-2001.

- 2,455,538. ESCORT. INT. CL. 22. (U.S. CLS. 1, 2, 7, 19, 22, 42 AND 50). REG. 5-29-2001.
- 2,456,561. WALLABIES. INT. CL. 25. (U.S. CLS. 22 AND 39). REG. 6-5-2001.
- 2,456,569. DIAMONDSHELL. INT. CL. 11. (U.S. CLS. 13, 21, 23, 31 AND 34). REG. 6-5-2001.
- 2,456,588. MISCELLANEOUS DESIGN. INT. CLS. 6 AND 21. (U.S. CLS. 2, 12, 13, 14, 23, 25, 29, 30, 33, 40 AND 50). REG. 6-5-2001.
- 2,456,621. HANOVER. INT. CL. 29. (U.S. CL. 46). REG. 6-5-2001.
- 2,456,695. DXN. INT. CL. 9. (U.S. CLS. 21, 23, 26, 36 AND 38). REG. 6-5-2001.
- 2,456,796. DOR 2 DOR. INT. CL. 40. (U.S. CLS. 100, 103 AND 106). REG. 6-5-2001.
- 2,456,877. SYNTAX. INT. CL. 42. (U.S. CLS. 100 AND 101). REG. 6-5-2001.
- 2,456,892. ENTREPRENEURIAL LEAGUE SYSTEM. INT. CL. 35. (U.S. CLS. 100, 101 AND 102). REG. 6-5-2001.
- 2,456,938. MAP ESSENTIALS. INT. CL. 16. (U.S. CLS. 2, 5, 22, 23, 29, 37, 38 AND 50). REG. 6-5-2001.
- 2,457,017. CASUAL JOE. INT. CL. 25. (U.S. CLS. 22 AND 39). REG. 6-5-2001.
- 2,457,069. BIRDWATCHERS' BLEND MORNING SONG AND DESIGN. INT. CL. 31. (U.S. CLS. 1 AND 46). REG. 6-5-2001.
- 2,457,244. EAA ULTRALIGHTS AND DESIGN. INT. CLS. 16, 25 AND 41. (U.S. CLS. 2, 5, 22, 23, 29, 37, 38, 39, 50, 100, 101 AND 107). REG. 6-5-2001.
- 2,457,265. FORCE 12 PROTECTION. INT. CL. 6. (U.S. CLS. 2, 12, 13, 14, 23, 25 AND 50). REG. 6-5-2001.
- 2,457,372. MISCELLANEOUS DESIGN. INT. CLS. 25 AND 41. (U.S. CLS. 22, 39, 100, 101 AND 107). REG. 6-5-2001.
- 2,457,377. ESCORT AND DESIGN. INT. CL. 22. (U.S. CLS. 1, 2, 7, 19, 22, 42 AND 50). REG. 6-5-2001.
- 2,457,511. VIOPHARMA INCORPORATED AND DESIGN. INT. CL. 5. (U.S. CLS. 6, 18, 44, 46, 51 AND 52). REG. 6-5-2001.
- 2,457,624. ORCHARD NU-LAX AND DESIGN. INT. CL. 5. (U.S. CLS. 6, 18, 44, 46, 51 AND 52). REG. 6-5-2001.
- 2,457,653. SEASONALE. INT. CL. 5. (U.S. CLS. 6, 18, 44, 46, 51 AND 52). REG. 6-5-2001.
- 2,457,733. THE MARINER. INT. CL. 11. (U.S. CLS. 13, 21, 23, 31 AND 34). REG. 6-5-2001.
- 2,457,756. NATIONAL GEOGRAPHIC CHANNEL AND DESIGN. INT. CL. 38. (U.S. CLS. 100, 101 AND 104). REG. 6-5-2001.
- 2,457,814. ACCUDRY. INT. CL. 9. (U.S. CLS. 21, 23, 26, 36 AND 38). REG. 6-5-2001.
- 2,457,943. LIL' KICKERS. INT. CL. 41. (U.S. CLS. 100, 101 AND 107). REG. 6-5-2001.
- 2,457,972. ULTRABRUSH. INT. CL. 10. (U.S. CLS. 26, 39 AND 44). REG. 6-5-2001.
- 2,458,017. EPIPURE. INT. CL. 1. (U.S. CLS. 1, 5, 6, 10, 26 AND 46). REG. 6-5-2001.
- 2,458,163. HOME SOLUTIONS. INT. CL. 27. (U.S. CLS. 19, 20, 37, 42 AND 50). REG. 6-5-2001.
- 2,458,178. BMC SOFTWARE AND DESIGN. INT. CL. 9. (U.S. CLS. 21, 23, 26, 36 AND 38). REG. 6-5-2001.
- 2,458,179. TULIP MATTE. INT. CL. 2. (U.S. CLS. 6, 11 AND 16). REG. 6-5-2001.
- 2,458,304. 14WOMEN. INT. CL. 42. (U.S. CLS. 100 AND 101). REG. 6-5-2001.
- 2,458,305. 14DESIGN. INT. CL. 42. (U.S. CLS. 100 AND 101). REG. 6-5-2001.
- 2,458,728. AUTOTUNING. INT. CL. 9. (U.S. CLS. 21, 23, 26, 36 AND 38). REG. 6-5-2001.
- 2,458,760. THE CABLE CENTER. INT. CLS. 41 AND 42. (U.S. CLS. 100, 101 AND 107). REG. 6-5-2001.
- 2,458,931. OSBORN. INT. CL. 5. (U.S. CLS. 6, 18, 44, 46, 51 AND 52). REG. 6-12-2001.
- 2,458,954. MISCELLANEOUS DESIGN. INT. CLS. 5, 8, 10 AND 12. (U.S. CLS. 6, 18, 19, 21, 23, 26, 28, 31, 35, 39, 44, 46, 51 AND 52). REG. 6-12-2001.
- 2,458,998. AVATAR. INT. CL. 42. (U.S. CLS. 100 AND 101). REG. 6-12-2001.
- 2,459,041. CADVERTER. INT. CL. 9. (U.S. CLS. 21, 23, 26, 36 AND 38). REG. 6-12-2001.
- 2,459,091. WV AND DESIGN. INT. CLS. 16 AND 35. (U.S. CLS. 2, 5, 22, 23, 29, 37, 38, 50, 100, 101 AND 102). REG. 6-12-2001.
- 2,459,259. RALPH KIMBALL ASSOCIATES. INT. CL. 41. (U.S. CLS. 100, 101 AND 107). REG. 6-12-2001.
- 2,459,261. RALPH KIMBALL ASSOCIATES. INT. CL. 35. (U.S. CLS. 100, 101 AND 102). REG. 6-12-2001.
- 2,459,354. MYSTIC SEAPORT BREWED USING THE FINEST INGREDIENTS FOR MYSTIC SEAPORT THE MUSEUM OF AMERICA AND THE SEA AND DESIGN. INT. CL. 32. (U.S. CLS. 45, 46 AND 48). REG. 6-12-2001.
- 2,459,405. NO DRAWING-SENSORY MARK. INT. CLS. 9, 37 AND 38 ONLY. (U.S. CLS. 21, 23, 26, 36, 38, 100, 101, 103, 104 AND 106). REG. 6-12-2001.
- 2,459,442. BLUE STREAK. INT. CL. 7. (U.S. CLS. 13, 19, 21, 23, 31, 34 AND 35). REG. 6-12-2001.
- 2,459,491. MISCELLANEOUS DESIGN. INT. CLS. 25 AND 28. (U.S. CLS. 22, 23, 38, 39 AND 50). REG. 6-12-2001.
- 2,459,597. ODOR WRANGLER. INT. CL. 37. (U.S. CLS. 100, 103 AND 106). REG. 6-12-2001.
- 2,459,628. BLISSFUL BEGINNINGS. INT. CL. 42. (U.S. CLS. 100 AND 101). REG. 6-12-2001.
- 2,459,730. HOTRON AND DESIGN. INT. CL. 9. (U.S. CLS. 21, 23, 26, 36 AND 38). REG. 6-12-2001.
- 2,459,794. SIGHTLINES. INT. CL. 36. (U.S. CLS. 100, 101 AND 102). REG. 6-12-2001.
- 2,459,907. VIOPHARMA. INT. CL. 5. (U.S. CLS. 6, 18, 44, 46, 51 AND 52). REG. 6-12-2001.
- 2,459,918. FUTURAMA. INT. CL. 28. (U.S. CLS. 22, 23, 38 AND 50). REG. 6-12-2001.
- 2,459,944. BULLDOG BASICS. INT. CL. 25. (U.S. CLS. 22 AND 39). REG. 6-12-2001.
- 2,459,952. MISCELLANEOUS DESIGN. INT. CL. 11. (U.S. CLS. 13, 21, 23, 31 AND 34). REG. 6-12-2001.
- 2,460,054. TWO-ONE-TWO 212 NEW YORK AND DESIGN. INT. CL. 25. (U.S. CLS. 22 AND 39). REG. 6-12-2001.
- 2,460,081. DERUNGS. INT. CL. 11. (U.S. CLS. 13, 21, 23, 31 AND 34). REG. 6-12-2001.
- 2,460,130. SCANTOX. INT. CL. 9. (U.S. CLS. 21, 23, 26, 36 AND 38). REG. 6-12-2001.
- 2,460,177. SONGBIRD. INT. CL. 10. (U.S. CLS. 26, 39 AND 44). REG. 6-12-2001.
- 2,460,263. SUPER SHERPA. INT. CL. 12. (U.S. CLS. 19, 21, 23, 31, 35 AND 44). REG. 6-12-2001.
- 2,460,420. FRANCHISE ESQ.. INT. CL. 35. (U.S. CLS. 100, 101 AND 102). REG. 6-12-2001.
- 2,460,528. IMAGEMOVERS. INT. CL. 41. (U.S. CLS. 100, 101 AND 107). REG. 6-12-2001.
- 2,460,533. SNOWLAND. INT. CL. 25. (U.S. CLS. 22 AND 39). REG. 6-12-2001.
- 2,460,544. STOXX 50. INT. CLS. 16, 35, 36, 38, 41 AND 42 ONLY. (U.S. CLS. 2, 5, 22, 23, 29, 37, 38, 50, 100, 101, 102, 104 AND 107). REG. 6-12-2001.
- 2,460,559. THE SEIZURE EXPERTS. INT. CLS. 41, 42 AND 44. (U.S. CLS. 100, 101 AND 107). REG. 6-12-2001.
- 2,460,777. SWEET POTATO QUEENS. INT. CL. 41. (U.S. CLS. 100, 101 AND 107). REG. 6-19-2001.
- 2,460,813. @I INTERNET ALASKA AND DESIGN. INT. CL. 38. (U.S. CLS. 100, 101 AND 104). REG. 6-19-2001.
- 2,460,841. WORX CLEAN- 'N-GENTLE AND DESIGN. INT. CL. 3. (U.S. CLS. 1, 4, 6, 50, 51 AND 52). REG. 6-19-2001.
- 2,461,108. BIOCLIP. INT. CL. 10. (U.S. CLS. 26, 39 AND 44). REG. 6-19-2001.
- 2,461,134. NBR. INT. CL. 42. (U.S. CLS. 100 AND 101). REG. 6-19-2001.
- 2,461,276. TYSON PROJECT A+ SUPPORT YOUR SCHOOL! AND DESIGN. INT. CL. 35. (U.S. CLS. 100, 101 AND 102). REG. 6-19-2001.
- 2,461,335. AQUAVATIONS. INT. CL. 40. (U.S. CLS. 100, 103 AND 106). REG. 6-19-2001.
- 2,461,343. THE PLUS PACKAGE. INT. CL. 35. (U.S. CLS. 100, 101 AND 102). REG. 6-19-2001.
- 2,461,368. NVIDIA QUADRO. INT. CL. 9. (U.S. CLS. 21, 23, 26, 36 AND 38). REG. 6-19-2001.
- 2,461,386. GLACE DE VIANDE (STYLIZED). INT. CL. 30. (U.S. CL. 46). REG. 6-19-2001.
- 2,461,427. SUNDEK AND DESIGN. INT. CLS. 19 AND 40. (U.S. CLS. 1, 12, 33, 50, 100, 103 AND 106). REG. 6-19-2001.
- 2,461,464. LINE-X. INT. CL. 40. (U.S. CLS. 100, 103 AND 106). REG. 6-19-2001.
- 2,461,557. LETHAL WEAPON. INT. CL. 25. (U.S. CLS. 22 AND 39). REG. 6-19-2001.

- 2,461,584. MMDTNET. INT. CL. 36. (U.S. CLS. 100, 101 AND 102). REG. 6-19-2001.
- 2,461,913. CYBERPULSE. INT. CL. 9. (U.S. CLS. 21, 23, 26, 36 AND 38). REG. 6-19-2001.
- 2,462,372. GEMS KITS. INT. CLS. 16 AND 28. (U.S. CLS. 2, 5, 22, 23, 29, 37, 38 AND 50). REG. 6-19-2001.
- 2,462,377. DISCOVER ENLIGHTEN SHARE NOURISH AND DESIGN. INT. CL. 42. (U.S. CLS. 100 AND 101). REG. 6-19-2001.
- 2,462,410. HEATWAVE. INT. CL. 11. (U.S. CLS. 13, 21, 23, 31 AND 34). REG. 6-19-2001.
- 2,462,594. THE CAMPAIGN FOR LIFE. INT. CL. 36. (U.S. CLS. 100, 101 AND 102). REG. 6-19-2001.
- 2,462,976. EDITORIAL SUDAMERICANA. INT. CL. 16. (U.S. CLS. 2, 5, 22, 23, 29, 37, 38 AND 50). REG. 6-19-2001.
- 2,463,171. GON BOPS OF CALIF. AND DESIGN. INT. CL. 15. (U.S. CLS. 2, 21 AND 36). REG. 6-26-2001.
- 2,463,252. ASK.COM. INT. CL. 42. (U.S. CLS. 100 AND 101). REG. 6-26-2001.
- 2,463,659. SENSI-FREE. INT. CL. 10. (U.S. CLS. 26, 39 AND 44). REG. 6-26-2001.
- 2,463,701. LINE X AND DESIGN. INT. CLS. 2 AND 40. (U.S. CLS. 6, 11, 16, 100, 103 AND 106). REG. 6-26-2001.
- 2,463,860. OXY-G2. INT. CL. 5. (U.S. CLS. 6, 18, 44, 46, 51 AND 52). REG. 6-26-2001.
- 2,463,912. ZYACIL. INT. CLS. 1, 17 AND 19. (U.S. CLS. 1, 5, 6, 10, 12, 13, 26, 33, 35, 46 AND 50). REG. 6-26-2001.
- 2,464,093. CREW CHIEF CLUB. INT. CL. 41 ONLY. (U.S. CLS. 100, 101 AND 107). REG. 6-26-2001.
- 2,464,369. IMAGES SALON. INT. CL. 42. (U.S. CLS. 100 AND 101). REG. 6-26-2001.
- 2,464,543. DEHNBRIDGE (STYLIZED). INT. CL. 9. (U.S. CLS. 21, 23, 26, 36 AND 38). REG. 6-26-2001.
- 2,464,544. DEHNGUARD (STYLIZED). INT. CL. 9. (U.S. CLS. 21, 23, 26, 36 AND 38). REG. 6-26-2001.
- 2,464,655. GLOBE UNION. INT. CLS. 11 AND 21. (U.S. CLS. 2, 13, 21, 23, 29, 30, 31, 33, 34, 40 AND 50). REG. 6-26-2001.
- 2,464,682. HENRY COTTON'S. INT. CL. 25. (U.S. CLS. 22 AND 39). REG. 6-26-2001.
- 2,464,779. KIDS HELPING KIDS. INT. CLS. 36 AND 42. (U.S. CLS. 100, 101 AND 102). REG. 7-3-2001.
- 2,464,810. CDI. INT. CL. 12 ONLY. (U.S. CLS. 19, 21, 23, 31, 35 AND 44). REG. 7-3-2001.
- 2,464,858. SPRING FOREST QIGONG AND DESIGN. INT. CL. 9. (U.S. CLS. 21, 23, 26, 36 AND 38). REG. 7-3-2001.
- 2,464,911. HOMEFREE. INT. CL. 36. (U.S. CLS. 100, 101 AND 102). REG. 7-3-2001.
- 2,464,920. CROWDER INDUSTRIAL. INT. CL. 37. (U.S. CLS. 100, 103 AND 106). REG. 7-3-2001.
- 2,465,069. HEM. INT. CL. 3. (U.S. CLS. 1, 4, 6, 50, 51 AND 52). REG. 7-3-2001.
- 2,465,070. LASER-LOK. INT. CL. 10. (U.S. CLS. 26, 39 AND 44). REG. 7-3-2001.
- 2,465,188. MISCELLANEOUS DESIGN. INT. CL. 25. (U.S. CLS. 22 AND 39). REG. 7-3-2001.
- 2,465,451. A FEAST FOR THE EARS. INT. CL. 41. (U.S. CLS. 100, 101 AND 107). REG. 7-3-2001.
- 2,465,617. FOUR-BLOCKS. INT. CL. 16. (U.S. CLS. 2, 5, 22, 23, 29, 37, 38 AND 50). REG. 7-3-2001.
- 2,465,915. JUST. INT. CL. 29. (U.S. CL. 46). REG. 7-3-2001.
- 2,466,274. SILVER LAKE PARTNERS. INT. CL. 36. (U.S. CLS. 100, 101 AND 102). REG. 7-3-2001.
- 2,466,275. SILVER LAKE. INT. CL. 36. (U.S. CLS. 100, 101 AND 102). REG. 7-3-2001.
- 2,466,315. MAKING CASH FLOW. INT. CLS. 35 AND 36. (U.S. CLS. 100, 101 AND 102). REG. 7-3-2001.
- 2,466,318. ZIP-TOGGLE. INT. CL. 6 ONLY. (U.S. CLS. 2, 12, 13, 14, 23, 25 AND 50). REG. 7-3-2001.
- 2,466,427. SORTDIRECTOR. INT. CL. 9. (U.S. CLS. 21, 23, 26, 36 AND 38). REG. 7-3-2001.
- 2,466,435. LIBRARY STUDIO. INT. CL. 9. (U.S. CLS. 21, 23, 26, 36 AND 38). REG. 7-3-2001.
- 2,466,684. INJURCARE (STYLIZED). INT. CL. 36. (U.S. CLS. 100, 101 AND 102). REG. 7-3-2001.
- 2,466,929. RUST-X. INT. CL. 3. (U.S. CLS. 1, 4, 6, 50, 51 AND 52). REG. 7-10-2001.
- 2,466,931. MOVEABLES. INT. CL. 20. (U.S. CLS. 2, 13, 22, 25, 32 AND 50). REG. 7-10-2001.
- 2,467,087. KIS. INT. CL. 9. (U.S. CLS. 21, 23, 26, 36 AND 38). REG. 7-10-2001.
- 2,467,103. TIGER TOOL INTERNATIONAL INCORPORATED AND DESIGN. INT. CL. 8. (U.S. CLS. 23, 28 AND 44). REG. 7-10-2001.
- 2,467,172. TLC. INT. CL. 9. (U.S. CLS. 21, 23, 26, 36 AND 38). REG. 7-10-2001.
- 2,467,286. BAKODA. INT. CL. 28. (U.S. CLS. 22, 23, 38 AND 50). REG. 7-10-2001.
- 2,467,350. THE TECHNOLOGY LEADER IN FALL PROTECTION SYSTEMS. INT. CL. 9. (U.S. CLS. 21, 23, 26, 36 AND 38). REG. 7-10-2001.
- 2,467,355. LEONISA (STYLIZED). INT. CL. 25. (U.S. CLS. 22 AND 39). REG. 7-10-2001.
- 2,467,405. KOBOLD. INT. CLS. 7, 16 AND 21. (U.S. CLS. 2, 5, 13, 19, 21, 22, 23, 29, 30, 31, 33, 34, 35, 37, 38, 40 AND 50). REG. 7-10-2001.
- 2,467,467. VALDAMOR. INT. CL. 33. (U.S. CLS. 47 AND 49). REG. 7-10-2001.
- 2,467,529. QUICKSTEP PLUS. INT. CL. 36. (U.S. CLS. 100, 101 AND 102). REG. 7-10-2001.
- 2,467,552. LEADING AT THE NEXT LEVEL. INT. CL. 16. (U.S. CLS. 2, 5, 22, 23, 29, 37, 38 AND 50). REG. 7-10-2001.
- 2,467,741. MISCELLANEOUS DESIGN. INT. CL. 24. (U.S. CLS. 42 AND 50). REG. 7-10-2001.
- 2,467,747. HOLIDAY EXPRESSIONS. INT. CL. 35. (U.S. CLS. 100, 101 AND 102). REG. 7-10-2001.
- 2,467,955. LEVERAGE. INT. CL. 28. (U.S. CLS. 22, 23, 38 AND 50). REG. 7-10-2001.
- 2,468,003. TOUGH GUY. INT. CL. 16. (U.S. CLS. 2, 5, 22, 23, 29, 37, 38 AND 50). REG. 7-10-2001.
- 2,468,036. MIN. INT. CL. 35. (U.S. CLS. 100, 101 AND 102). REG. 7-10-2001.
- 2,468,051. JUMBO (STYLIZED). INT. CL. 29. (U.S. CL. 46). REG. 7-10-2001.
- 2,468,093. EGS ELECTRICAL GROUP. INT. CLS. 9 AND 11. (U.S. CLS. 13, 21, 23, 26, 31, 34, 36 AND 38). REG. 7-10-2001.
- 2,468,094. EGS ELECTRICAL GROUP AND DESIGN. INT. CLS. 9 AND 11. (U.S. CLS. 13, 21, 23, 26, 31, 34, 36 AND 38). REG. 7-10-2001.
- 2,468,153. THE TRUMP SPA. INT. CLS. 41 AND 42. (U.S. CLS. 100, 101 AND 107). REG. 7-10-2001.
- 2,468,276. SAFE@PLAY. INT. CL. 9. (U.S. CLS. 21, 23, 26, 36 AND 38). REG. 7-10-2001.
- 2,468,285. NEUBERGER BERMAN ADVISERS MANAGEMENT TRUST GROWTH PORTFOLIO. INT. CL. 36. (U.S. CLS. 100, 101 AND 102). REG. 7-10-2001.
- 2,468,323. HALUX. INT. CL. 11. (U.S. CLS. 13, 21, 23, 31 AND 34). REG. 7-10-2001.
- 2,468,331. CLASSIC COTTON. INT. CL. 16. (U.S. CLS. 2, 5, 22, 23, 29, 37, 38 AND 50). REG. 7-10-2001.
- 2,468,385. EYE-CETERA. INT. CL. 35. (U.S. CLS. 100, 101 AND 102). REG. 7-10-2001.
- 2,468,517. MEDPACE. INT. CL. 42. (U.S. CLS. 100 AND 101). REG. 7-10-2001.
- 2,468,519. WORLD PREP. INT. CL. 9. (U.S. CLS. 21, 23, 26, 36 AND 38). REG. 7-10-2001.
- 2,468,557. THE BROADBAND GROUP. INT. CL. 42. (U.S. CLS. 100 AND 101). REG. 7-10-2001.
- 2,468,607. DREDGING WORLDWIDE. INT. CL. 37. (U.S. CLS. 100, 103 AND 106). REG. 7-10-2001.
- 2,468,613. DEC (STYLIZED). INT. CLS. 36 AND 42. (U.S. CLS. 100, 101 AND 102). REG. 7-17-2001.
- 2,468,651. WEEKENDS. INT. CL. 35. (U.S. CLS. 100, 101 AND 102). REG. 7-17-2001.
- 2,468,692. MISCELLANEOUS DESIGN. INT. CL. 6. (U.S. CLS. 2, 12, 13, 14, 23, 25 AND 50). REG. 7-17-2001.
- 2,468,720. FABRIC FRIENDLY. INT. CL. 3. (U.S. CLS. 1, 4, 6, 50, 51 AND 52). REG. 7-17-2001.
- 2,468,743. FTM. INT. CLS. 9, 41 AND 42. (U.S. CLS. 21, 23, 26, 36, 38, 100, 101 AND 107). REG. 7-17-2001.
- 2,468,758. CB COHEN BROWN MANAGEMENT GROUP, INC. (STYLIZED). INT. CL. 41. (U.S. CLS. 100, 101 AND 107). REG. 7-17-2001.
- 2,468,846. CAVALIER HOMES, INC. INT. CL. 35. (U.S. CLS. 100, 101 AND 102). REG. 7-17-2001.
- 2,468,888. COASTAL SEEDS. INT. CL. 31. (U.S. CLS. 1 AND 46). REG. 7-17-2001.
- 2,468,929. GATEWAY GIFT SHOP. INT. CL. 35. (U.S. CLS. 100, 101 AND 102). REG. 7-17-2001.
- 2,468,974. BELLEVUE PLACE. INT. CLS. 36 AND 37. (U.S. CLS. 100, 101, 102, 103 AND 106). REG. 7-17-2001.
- 2,468,992. MVU (STYLIZED). INT. CL. 41. (U.S. CLS. 100, 101 AND 107). REG. 7-17-2001.

- 2,469,016. CROWN OVAL. INT. CL. 21. (U.S. CLS. 2, 13, 23, 29, 30, 33, 40 AND 50). REG. 7-17-2001.
- 2,469,077. SKANDIS SYSTEMS AND DESIGN. INT. CL. 42. (U.S. CLS. 100 AND 101). REG. 7-17-2001.
- 2,469,197. WHERE WALL STREET AND MAIN STREET MEET. INT. CL. 41. (U.S. CLS. 100, 101 AND 107). REG. 7-17-2001.
- 2,469,228. ONECROWN. INT. CL. 42. (U.S. CLS. 100 AND 101). REG. 7-17-2001.
- 2,469,252. SCOJO. INT. CL. 9. (U.S. CLS. 21, 23, 26, 36 AND 38). REG. 7-17-2001.
- 2,469,254. INGO MAURER. INT. CL. 11 ONLY. (U.S. CLS. 13, 21, 23, 31 AND 34). REG. 7-17-2001.
- 2,469,301. U. S. STEEL STANDARD CHARACTER MARK. INT. CL. 6. (U.S. CLS. 2, 12, 13, 14, 23, 25 AND 50). REG. 7-17-2001.
- 2,469,401. EDDIE BAUER. INT. CLS. 3, 4 AND 11. (U.S. CLS. 1, 4, 6, 13, 15, 21, 23, 31, 34, 50, 51 AND 52). REG. 7-17-2001.
- 2,469,436. BETTER VALU. INT. CLS. 3, 6, 16, 21, 29, 30, 31 AND 32. (U.S. CLS. 1, 2, 4, 5, 6, 12, 13, 14, 22, 23, 25, 29, 30, 33, 37, 38, 40, 45, 46, 48, 50, 51 AND 52). REG. 7-17-2001.
- 2,469,441. PLAYBOY. INT. CL. 21. (U.S. CLS. 2, 13, 23, 29, 30, 33, 40 AND 50). REG. 7-17-2001.
- 2,469,529. GLOMAR. INT. CL. 11. (U.S. CLS. 13, 21, 23, 31 AND 34). REG. 7-17-2001.
- 2,469,553. MISCELLANEOUS DESIGN. INT. CL. 25. (U.S. CLS. 22 AND 39). REG. 7-17-2001.
- 2,469,567. GASPEDAL. INT. CL. 35. (U.S. CLS. 100, 101 AND 102). REG. 7-17-2001.
- 2,469,591. WEBBILL. INT. CL. 36. (U.S. CLS. 100, 101 AND 102). REG. 7-17-2001.
- 2,469,658. MISCELLANEOUS DESIGN. INT. CL. 16. (U.S. CLS. 2, 5, 22, 23, 29, 37, 38 AND 50). REG. 7-17-2001.
- 2,469,702. FRUKO Y SUS TESOS. INT. CL. 9. (U.S. CLS. 21, 23, 26, 36 AND 38). REG. 7-17-2001.
- 2,469,733. MISCELLANEOUS DESIGN. INT. CL. 13. (U.S. CLS. 2 AND 9). REG. 7-17-2001.
- 2,469,781. AGENDA DE DECORACION. INT. CL. 16. (U.S. CLS. 2, 5, 22, 23, 29, 37, 38 AND 50). REG. 7-17-2001.
- 2,469,784. CUCHECK. INT. CL. 36. (U.S. CLS. 100, 101 AND 102). REG. 7-17-2001.
- 2,469,813. TECHTOPIA. INT. CL. 16 ONLY. (U.S. CLS. 2, 5, 22, 23, 29, 37, 38 AND 50). REG. 7-17-2001.
- 2,469,817. THE SCIENCE OF EUREKA!. INT. CL. 41. (U.S. CLS. 100, 101 AND 107). REG. 7-17-2001.
- 2,469,845. MULSEAL. INT. CL. 2. (U.S. CLS. 6, 11 AND 16). REG. 7-17-2001.
- 2,469,850. THERMOSTEAM. INT. CL. 11. (U.S. CLS. 13, 21, 23, 31 AND 34). REG. 7-17-2001.
- 2,469,922. OPTOS. INT. CLS. 10 AND 42. (U.S. CLS. 26, 39, 44, 100 AND 101). REG. 7-17-2001.
- 2,470,027. TESORO. INT. CL. 40. (U.S. CLS. 100, 103 AND 106). REG. 7-17-2001.
- 2,470,049. ROTAGLIDE. INT. CL. 4. (U.S. CLS. 1, 6 AND 15). REG. 7-17-2001.
- 2,470,067. VOTI-FLEUR. INT. CL. 4. (U.S. CLS. 1, 6 AND 15). REG. 7-17-2001.
- 2,470,129. MEADOWBROOK. INT. CL. 20. (U.S. CLS. 2, 13, 22, 25, 32 AND 50). REG. 7-17-2001.
- 2,470,177. ACCUVISION. INT. CL. 3. (U.S. CLS. 1, 4, 6, 50, 51 AND 52). REG. 7-17-2001.
- 2,470,189. SYRIS SCIENTIFIC. INT. CL. 9. (U.S. CLS. 21, 23, 26, 36 AND 38). REG. 7-17-2001.
- 2,470,228. A ARDUS MEDICAL, INC. AND DESIGN. INT. CL. 10. (U.S. CLS. 26, 39 AND 44). REG. 7-17-2001.
- 2,470,241. DYNAMIC COOKING SYSTEMS. INT. CL. 11. (U.S. CLS. 13, 21, 23, 31 AND 34). REG. 7-17-2001.
- 2,470,337. TEXAS EDITION. INT. CL. 36. (U.S. CLS. 100, 101 AND 102). REG. 7-17-2001.
- 2,470,410. LEE MEDICAL. INT. CLS. 35 AND 42. (U.S. CLS. 100, 101 AND 102). REG. 7-17-2001.
- 2,470,412. INTACCT. INT. CLS. 35 AND 39. (U.S. CLS. 100, 101, 102 AND 105). REG. 7-17-2001.
- 2,470,454. NINQUEN. INT. CL. 33. (U.S. CLS. 47 AND 49). REG. 7-17-2001.
- 2,470,570. DUCT DIAPER. INT. CL. 11. (U.S. CLS. 13, 21, 23, 31 AND 34). REG. 7-17-2001.
- 2,470,816. MISCELLANEOUS DESIGN. INT. CL. 5. (U.S. CLS. 6, 18, 44, 46, 51 AND 52). REG. 7-24-2001.
- 2,470,848. OCU-MAX. INT. CL. 5. (U.S. CLS. 6, 18, 44, 46, 51 AND 52). REG. 7-24-2001.
- 2,470,877. RETI.C. INT. CL. 3. (U.S. CLS. 1, 4, 6, 50, 51 AND 52). REG. 7-24-2001.
- 2,470,890. MISCELLANEOUS DESIGN. INT. CL. 42 ONLY. (U.S. CLS. 100 AND 101). REG. 7-24-2001.
- 2,470,898. ACOUSTIC AND DESIGN. INT. CL. 9. (U.S. CLS. 21, 23, 26, 36 AND 38). REG. 7-24-2001.
- 2,470,903. SPORTSMIND. INT. CL. 41. (U.S. CLS. 100, 101 AND 107). REG. 7-24-2001.
- 2,471,003. MISCELLANEOUS DESIGN. INT. CLS. 29 AND 30. (U.S. CL. 46). REG. 7-24-2001.
- 2,471,025. DRIVEN BY ELMOS. INT. CL. 9. (U.S. CLS. 21, 23, 26, 36 AND 38). REG. 7-24-2001.
- 2,471,035. CALIFORNIA CAFE BAR & GRILL. INT. CL. 42. (U.S. CLS. 100 AND 101). REG. 7-24-2001.
- 2,471,039. SUGAR MEMORIES. INT. CL. 30. (U.S. CL. 46). REG. 7-24-2001.
- 2,471,040. ORECK XL. INT. CL. 7. (U.S. CLS. 13, 19, 21, 23, 31, 34 AND 35). REG. 7-24-2001.
- 2,471,249. GALLOPADE. INT. CL. 16. (U.S. CLS. 2, 5, 22, 23, 29, 37, 38 AND 50). REG. 7-24-2001.
- 2,471,251. CAROLE MARSH. INT. CL. 16. (U.S. CLS. 2, 5, 22, 23, 29, 37, 38 AND 50). REG. 7-24-2001.
- 2,471,562. DERMATOS. INT. CL. 10. (U.S. CLS. 26, 39 AND 44). REG. 7-24-2001.
- 2,471,652. VITALP. INT. CLS. 5 AND 30. (U.S. CLS. 6, 18, 44, 46, 51 AND 52). REG. 7-24-2001.
- 2,471,730. AAP (STYLIZED). INT. CL. 42. (U.S. CLS. 100 AND 101). REG. 7-24-2001.
- 2,471,761. QUADROX. INT. CL. 10. (U.S. CLS. 26, 39 AND 44). REG. 7-24-2001.
- 2,471,844. M MERQUINSA (STYLIZED). INT. CL. 1. (U.S. CLS. 1, 5, 6, 10, 26 AND 46). REG. 7-24-2001.
- 2,471,859. ABSOLUTE COMFORT SYSTEM. INT. CLS. 20 AND 24. (U.S. CLS. 2, 13, 22, 25, 32, 42 AND 50). REG. 7-24-2001.
- 2,471,883. BONE DADDY'S STANDARD CHARACTER MARK. INT. CL. 42. (U.S. CLS. 100 AND 101). REG. 7-24-2001.
- 2,471,934. POWERED BY PEGASUS. INT. CLS. 39 AND 42. (U.S. CLS. 100, 101 AND 105). REG. 7-24-2001.
- 2,472,067. VANILLA VELVET. INT. CL. 1. (U.S. CLS. 1, 5, 6, 10, 26 AND 46). REG. 7-24-2001.
- 2,472,145. AERIES. INT. CL. 9. (U.S. CLS. 21, 23, 26, 36 AND 38). REG. 7-24-2001.
- 2,472,176. ROAD WIZARD. INT. CL. 12. (U.S. CLS. 19, 21, 23, 31, 35 AND 44). REG. 7-24-2001.
- 2,472,508. THE CAP COMPANY. INT. CL. 20. (U.S. CLS. 2, 13, 22, 25, 32 AND 50). REG. 7-24-2001.
- 2,472,627. ZETAFAAX. INT. CL. 9. (U.S. CLS. 21, 23, 26, 36 AND 38). REG. 7-31-2001.
- 2,472,642. ALCOM (STYLIZED). INT. CL. 1. (U.S. CLS. 1, 5, 6, 10, 26 AND 46). REG. 7-31-2001.
- 2,472,695. ALPINE AND DESIGN. INT. CLS. 6, 7 AND 42. (U.S. CLS. 2, 12, 13, 14, 19, 21, 23, 25, 31, 34, 35, 50, 100 AND 101). REG. 7-31-2001.
- 2,472,821. SHOWEAST. INT. CL. 35. (U.S. CLS. 100, 101 AND 102). REG. 7-31-2001.
- 2,472,951. SUCCESS WORLD (STYLIZED). INT. CL. 9. (U.S. CLS. 21, 23, 26, 36 AND 38). REG. 7-31-2001.
- 2,473,031. 21ST CENTURY NUTRITION PUBLISHING. INT. CL. 16. (U.S. CLS. 2, 5, 22, 23, 29, 37, 38 AND 50). REG. 7-31-2001.
- 2,473,084. BUILDERS CLUB. INT. CL. 41. (U.S. CLS. 100, 101 AND 107). REG. 7-31-2001.
- 2,473,089. LEADER BEHAVIOR ANALYSIS II. INT. CL. 16. (U.S. CLS. 2, 5, 22, 23, 29, 37, 38 AND 50). REG. 7-31-2001.
- 2,473,090. CRAZY DOG AND DESIGN. INT. CL. 25. (U.S. CLS. 22 AND 39). REG. 7-31-2001.
- 2,473,249. BCTGM BAKERY CONFECTIONERY TOBACCO WORKERS & GRAIN MILLERS UNION MADE AFL-CIO CLC AND DESIGN. U.S. CL. 200. REG. 7-31-2001.
- 2,473,311. TODD. INT. CLS. 11, 37, 40 AND 42. (U.S. CLS. 13, 21, 23, 31, 34, 100, 101, 103 AND 106). REG. 7-31-2001.
- 2,473,463. TAX LADIES AND DESIGN. INT. CL. 35. (U.S. CLS. 100, 101 AND 102). REG. 7-31-2001.
- 2,473,480. DURA KLEAR. INT. CL. 12. (U.S. CLS. 19, 21, 23, 31, 35 AND 44). REG. 7-31-2001.
- 2,473,603. LANTIS FIREWORKS & LASERS. INT. CL. 41. (U.S. CLS. 100, 101 AND 107). REG. 7-31-2001.

- 2,473,668. CELTIC LEASING. INT. CL. 36. (U.S. CLS. 100, 101 AND 102). REG. 7-31-2001.
- 2,473,755. THE LEAK STOPS HERE. INT. CL. 35. (U.S. CLS. 100, 101 AND 102). REG. 7-31-2001.
- 2,473,756. WE GIVE YOU THE CALM AFTER THE STORM. INT. CL. 35. (U.S. CLS. 100, 101 AND 102). REG. 7-31-2001.
- 2,473,850. MISCELLANEOUS DESIGN. INT. CL. 21. (U.S. CLS. 2, 13, 23, 29, 30, 33, 40 AND 50). REG. 7-31-2001.
- 2,473,866. MISCELLANEOUS DESIGN. INT. CL. 25. (U.S. CLS. 22 AND 39). REG. 7-31-2001.
- 2,473,898. TECSKOR. INT. CLS. 9, 35, 41 AND 42. (U.S. CLS. 21, 23, 26, 36, 38, 100, 101, 102 AND 107). REG. 7-31-2001.
- 2,473,908. KAISERCUTTINGEDGE.COM. INT. CL. 35. (U.S. CLS. 100, 101 AND 102). REG. 7-31-2001.
- 2,473,920. COOL THINGS. INT. CLS. 16, 20 AND 28. (U.S. CLS. 2, 5, 13, 22, 23, 25, 29, 32, 37, 38 AND 50). REG. 7-31-2001.
- 2,473,954. TESORO. INT. CL. 35. (U.S. CLS. 100, 101 AND 102). REG. 7-31-2001.
- 2,474,059. GREY ALLIANCE. INT. CLS. 35 AND 41. (U.S. CLS. 100, 101, 102 AND 107). REG. 7-31-2001.
- 2,474,091. BIOGARD. INT. CL. 2. (U.S. CLS. 6, 11 AND 16). REG. 7-31-2001.
- 2,474,125. FCM. INT. CLS. 6 AND 19. (U.S. CLS. 1, 2, 12, 13, 14, 23, 25, 33 AND 50). REG. 7-31-2001.
- 2,474,128. PERFORMANCE TRUCK AND DESIGN. INT. CL. 12. (U.S. CLS. 19, 21, 23, 31, 35 AND 44). REG. 7-31-2001.
- 2,474,129. PERFORMANCE RENTAL AND DESIGN. INT. CL. 39. (U.S. CLS. 100 AND 105). REG. 7-31-2001.
- 2,474,174. PERFORMANCE EXPORT AND DESIGN. INT. CL. 12. (U.S. CLS. 19, 21, 23, 31, 35 AND 44). REG. 7-31-2001.
- 2,474,242. SCHOELLERSHAMMER. INT. CL. 16. (U.S. CLS. 2, 5, 22, 23, 29, 37, 38 AND 50). REG. 7-31-2001.
- 2,474,253. MASTER SEED AND DESIGN. INT. CL. 22. (U.S. CLS. 1, 2, 7, 19, 22, 42 AND 50). REG. 7-31-2001.
- 2,474,271. CENTRIFLEX. INT. CL. 28. (U.S. CLS. 22, 23, 38 AND 50). REG. 7-31-2001.
- 2,474,283. TIFLEX. INT. CL. 9. (U.S. CLS. 21, 23, 26, 36 AND 38). REG. 7-31-2001.
- 2,474,306. INTERNATIONAL CENTRE FOR MISSING & EXPLOITED CHILDREN. INT. CL. 42. (U.S. CLS. 100 AND 101). REG. 7-31-2001.
- 2,474,334. TRISTAR HEALTH SYSTEM. INT. CL. 42. (U.S. CLS. 100 AND 101). REG. 7-31-2001.
- 2,474,335. TRISTAR HEALTH SYSTEM. INT. CL. 35. (U.S. CLS. 100, 101 AND 102). REG. 7-31-2001.
- 2,474,399. PAYDQ. INT. CL. 36. (U.S. CLS. 100, 101 AND 102). REG. 7-31-2001.
- 2,474,459. MISCELLANEOUS DESIGN. INT. CL. 38. (U.S. CLS. 100, 101 AND 104). REG. 7-31-2001.
- 2,474,554. PAWS FOR HEALTH. INT. CL. 42. (U.S. CLS. 100 AND 101). REG. 7-31-2001.
- 2,474,660. TRAVELER SENTIMENT INDEX. INT. CL. 35. (U.S. CLS. 100, 101 AND 102). REG. 7-31-2001.
- 2,474,742. JOB MANAGEMENT PARTNER 1. INT. CL. 9. (U.S. CLS. 21, 23, 26, 36 AND 38). REG. 8-7-2001.
- 2,474,863. MISCELLANEOUS DESIGN. INT. CLS. 16 AND 41 ONLY. (U.S. CLS. 2, 5, 22, 23, 29, 37, 38, 50, 100, 101 AND 107). REG. 8-7-2001.
- 2,474,864. WORLD FIGURE SKATING CHAMPIONSHIPS. INT. CL. 41. (U.S. CLS. 100, 101 AND 107). REG. 8-7-2001.
- 2,475,069. RTI. INT. CL. 42. (U.S. CLS. 100 AND 101). REG. 8-7-2001.
- 2,475,243. AUTOFUTURES. INT. CLS. 16 AND 35. (U.S. CLS. 2, 5, 22, 23, 29, 37, 38, 50, 100, 101 AND 102). REG. 8-7-2001.
- 2,475,483. HICKORY DICKORY DECKS. INT. CL. 19. (U.S. CLS. 1, 12, 33 AND 50). REG. 8-7-2001.
- 2,475,839. PURPLEFINDER. INT. CL. 9. (U.S. CLS. 21, 23, 26, 36 AND 38). REG. 8-7-2001.
- 2,475,922. AIRLINER. INT. CL. 12. (U.S. CLS. 19, 21, 23, 31, 35 AND 44). REG. 8-7-2001.
- 2,476,069. ROSE BOWL AND DESIGN. INT. CLS. 6, 21, 25 AND 28 ONLY. (U.S. CLS. 2, 12, 13, 14, 22, 23, 25, 29, 30, 33, 38, 39, 40 AND 50). REG. 8-7-2001.
- 2,476,163. LE MERIGOT. INT. CL. 42. (U.S. CLS. 100 AND 101). REG. 8-7-2001.
- 2,476,204. ONI. INT. CL. 9. (U.S. CLS. 21, 23, 26, 36 AND 38). REG. 8-7-2001.
- 2,476,229. ... AND WE DELIVER. INT. CL. 37 ONLY. (U.S. CLS. 100, 103 AND 106). REG. 8-7-2001.
- 2,476,471. GORILLA DECK. INT. CL. 19. (U.S. CLS. 1, 12, 33 AND 50). REG. 8-7-2001.
- 2,476,507. TERRUS REAL ESTATE GROUP. INT. CLS. 35, 36, 37 AND 42. (U.S. CLS. 100, 101, 102, 103 AND 106). REG. 8-7-2001.
- 2,476,518. EZE-BAND LF. INT. CL. 10. (U.S. CLS. 26, 39 AND 44). REG. 8-7-2001.
- 2,476,530. CONWISE AND DESIGN. INT. CL. 9. (U.S. CLS. 21, 23, 26, 36 AND 38). REG. 8-7-2001.
- 2,476,549. OUTLAST. INT. CL. 3. (U.S. CLS. 1, 4, 6, 50, 51 AND 52). REG. 8-7-2001.
- 2,476,551. FUZZYS. INT. CL. 10. (U.S. CLS. 26, 39 AND 44). REG. 8-7-2001.
- 2,476,906. SIGNET. INT. CL. 8. (U.S. CLS. 23, 28 AND 44). REG. 8-14-2001.
- 2,476,944. MAGNUM GOBBLE DOT. INT. CL. 13. (U.S. CLS. 2 AND 9). REG. 8-14-2001.
- 2,477,073. WORLD JUNIOR FIGURE SKATING CHAMPIONSHIPS. INT. CL. 41. (U.S. CLS. 100, 101 AND 107). REG. 8-14-2001.
- 2,477,160. OCEANS LIVE. INT. CL. 41. (U.S. CLS. 100, 101 AND 107). REG. 8-14-2001.
- 2,477,163. THERMOTRON AND DESIGN. INT. CL. 9. (U.S. CLS. 21, 23, 26, 36 AND 38). REG. 8-14-2001.
- 2,477,187. UP FOOTGEAR. INT. CL. 35. (U.S. CLS. 100, 101 AND 102). REG. 8-14-2001.
- 2,477,349. MISCELLANEOUS DESIGN. INT. CLS. 35, 36 AND 41. (U.S. CLS. 100, 101, 102 AND 107). REG. 8-14-2001.
- 2,477,845. VILLE ET VILLAGE FRENCH HOLIDAY RENTALS AND DESIGN. INT. CL. 42. (U.S. CLS. 100 AND 101). REG. 8-14-2001.
- 2,478,340. THE TRUMP SPA AT MAR A LAGO. INT. CLS. 41 AND 42. (U.S. CLS. 100, 101 AND 107). REG. 8-14-2001.
- 2,478,468. GIA GEMOLOGICAL INSTITUTE OF AMERICA AND DESIGN. INT. CL. 9. (U.S. CLS. 21, 23, 26, 36 AND 38). REG. 8-14-2001.
- 2,478,540. N AND DESIGN. INT. CL. 35. (U.S. CLS. 100, 101 AND 102). REG. 8-14-2001.
- 2,478,773. FLEX. INT. CL. 9. (U.S. CLS. 21, 23, 26, 36 AND 38). REG. 8-21-2001.
- 2,478,854. NATIONAL GYPSUM AND DESIGN. INT. CL. 16. (U.S. CLS. 2, 5, 22, 23, 29, 37, 38 AND 50). REG. 8-21-2001.
- 2,478,933. QUICK DIP. INT. CL. 1. (U.S. CLS. 1, 5, 6, 10, 26 AND 46). REG. 8-21-2001.
- 2,478,962. JACKPOT. INT. CL. 1. (U.S. CLS. 1, 5, 6, 10, 26 AND 46). REG. 8-21-2001.
- 2,479,010. MISCELLANEOUS DESIGN. INT. CL. 12. (U.S. CLS. 19, 21, 23, 31, 35 AND 44). REG. 8-21-2001.
- 2,479,039. RAVEN. INT. CL. 9. (U.S. CLS. 21, 23, 26, 36 AND 38). REG. 8-21-2001.
- 2,479,139. SENICTRIM. INT. CL. 30. (U.S. CL. 46). REG. 8-21-2001.
- 2,479,276. LOCOS. INT. CL. 42. (U.S. CLS. 100 AND 101). REG. 8-21-2001.
- 2,479,315. APETONIL. INT. CL. 5. (U.S. CLS. 6, 18, 44, 46, 51 AND 52). REG. 8-21-2001.
- 2,479,445. NETCENTRAL. INT. CL. 9. (U.S. CLS. 21, 23, 26, 36 AND 38). REG. 8-21-2001.
- 2,479,498. WHAT A GREAT IDEA. INT. CL. 41. (U.S. CLS. 100, 101 AND 107). REG. 8-21-2001.
- 2,479,742. MISCELLANEOUS DESIGN. INT. CL. 41. (U.S. CLS. 100, 101 AND 107). REG. 8-21-2001.
- 2,479,749. ROSE & WALKER DRYWALL AND INSULATION AND DESIGN. INT. CL. 35. (U.S. CLS. 100, 101 AND 102). REG. 8-21-2001.
- 2,479,846. SUPERFINISHER AND DESIGN. INT. CL. 7. (U.S. CLS. 13, 19, 21, 23, 31, 34 AND 35). REG. 8-21-2001.
- 2,479,900. GELATO. INT. CL. 5. (U.S. CLS. 6, 18, 44, 46, 51 AND 52). REG. 8-21-2001.
- 2,480,044. KICU. INT. CL. 38. (U.S. CLS. 100, 101 AND 104). REG. 8-21-2001.
- 2,480,063. MISCELLANEOUS DESIGN. INT. CLS. 41 AND 42. (U.S. CLS. 100, 101 AND 107). REG. 8-21-2001.
- 2,480,154. BED & BREAD CLUB. INT. CL. 36. (U.S. CLS. 100, 101 AND 102). REG. 8-21-2001.
- 2,480,301. ACUVANCE. INT. CL. 10. (U.S. CLS. 26, 39 AND 44). REG. 8-21-2001.
- 2,480,397. PRO-SELECT. INT. CL. 10. (U.S. CLS. 26, 39 AND 44). REG. 8-21-2001.

- 2,480,436. FUTURE. INT. CLS. 35, 37 AND 42. (U.S. CLS. 100, 101, 102, 103 AND 106). REG. 8-21-2001.
- 2,480,581. GEMINI AUTOMOTIVE CARE AND DESIGN. INT. CLS. 35 AND 37. (U.S. CLS. 100, 101, 102, 103 AND 106). REG. 8-21-2001.
- 2,480,919. TRADESPHERE. INT. CL. 9 ONLY. (U.S. CLS. 21, 23, 26, 36 AND 38). REG. 8-21-2001.
- 2,481,167. CUNINGHAM GROUP. INT. CL. 42 ONLY. (U.S. CLS. 100 AND 101). REG. 8-28-2001.
- 2,481,211. FRIAMAT. INT. CL. 9. (U.S. CLS. 21, 23, 26, 36 AND 38). REG. 8-28-2001.
- 2,481,614. JEBSEE. INT. CL. 9. (U.S. CLS. 21, 23, 26, 36 AND 38). REG. 8-28-2001.
- 2,481,642. MISCELLANEOUS DESIGN. INT. CL. 36. (U.S. CLS. 100, 101 AND 102). REG. 8-28-2001.
- 2,481,823. KID TIMBER. INT. CL. 19. (U.S. CLS. 1, 12, 33 AND 50). REG. 8-28-2001.
- 2,482,206. J-50. INT. CL. 15. (U.S. CLS. 2, 21 AND 36). REG. 8-28-2001.
- 2,482,405. LEGENDS OF GOLF STANDARD CHARACTER MARK. INT. CL. 41. (U.S. CLS. 100, 101 AND 107). REG. 8-28-2001.
- 2,482,406. ODM. INT. CL. 25. (U.S. CLS. 22 AND 39). REG. 8-28-2001.
- 2,482,670. MAKAHA. INT. CL. 25. (U.S. CLS. 22 AND 39). REG. 8-28-2001.
- 2,482,789. CONTADINA. INT. CL. 42. (U.S. CLS. 100 AND 101). REG. 8-28-2001.
- 2,483,097. LEVITATOR. INT. CL. 20. (U.S. CLS. 2, 13, 22, 25, 32 AND 50). REG. 8-28-2001.
- 2,483,226. LEE VALLEY. INT. CL. 25. (U.S. CLS. 22 AND 39). REG. 8-28-2001.
- 2,483,496. PARTNERSINWEALTH. INT. CL. 36. (U.S. CLS. 100, 101 AND 102). REG. 8-28-2001.
- 2,483,504. COLORXPRESS. INT. CL. 40. (U.S. CLS. 100, 103 AND 106). REG. 8-28-2001.
- 2,483,886. AKRON GENERAL MEDICAL CENTER. INT. CLS. 35 AND 42. (U.S. CLS. 100, 101 AND 102). REG. 8-28-2001.
- 2,484,126. NOLAP. INT. CL. 9. (U.S. CLS. 21, 23, 26, 36 AND 38). REG. 9-4-2001.
- 2,484,315. UBIQUITY RECORDS. INT. CL. 41. (U.S. CLS. 100, 101 AND 107). REG. 9-4-2001.
- 2,484,368. MONARCH. INT. CL. 8. (U.S. CLS. 23, 28 AND 44). REG. 9-4-2001.
- 2,485,143. RAL. INT. CL. 42. (U.S. CLS. 100 AND 101). REG. 9-4-2001.
- 2,485,312. GARDEN GREETINGS. INT. CL. 19. (U.S. CLS. 1, 12, 33 AND 50). REG. 9-4-2001.
- 2,486,445. T.J. MAXX. INT. CLS. 3 AND 28. (U.S. CLS. 1, 4, 6, 22, 23, 38, 50, 51 AND 52). REG. 9-11-2001.
- 2,486,751. CC (STYLIZED). INT. CLS. 41 AND 42. (U.S. CLS. 100, 101 AND 107). REG. 9-11-2001.
- 2,486,994. HIDDEN HITCH AND DESIGN. INT. CL. 12. (U.S. CLS. 19, 21, 23, 31, 35 AND 44). REG. 9-11-2001.
- 2,487,586. ELUTRON. INT. CL. 6. (U.S. CLS. 2, 12, 13, 14, 23, 25 AND 50). REG. 9-11-2001.
- 2,487,861. JUMBOSPRINT. INT. CLS. 7, 9 AND 17 ONLY. (U.S. CLS. 1, 5, 12, 13, 19, 21, 23, 26, 31, 34, 35, 36, 38 AND 50). REG. 9-11-2001.
- 2,488,507. JUSTBAKE. INT. CL. 30. (U.S. CL. 46). REG. 9-11-2001.
- 2,488,617. HYDROEXCAVATOR VACTOR AND DESIGN. INT. CL. 7. (U.S. CLS. 13, 19, 21, 23, 31, 34 AND 35). REG. 9-11-2001.
- 2,488,674. TOYOTOMI AMERICA AND DESIGN. INT. CL. 40. (U.S. CLS. 100, 103 AND 106). REG. 9-11-2001.
- 2,489,132. MYMEDEX. INT. CL. 35. (U.S. CLS. 100, 101 AND 102). REG. 9-11-2001.
- 2,489,321. SHARING THE KNOWLEDGE FOR BETTER HEALTH. INT. CL. 42. (U.S. CLS. 100 AND 101). REG. 9-11-2001.
- 2,490,565. CAR WASH USA AND DESIGN. INT. CL. 37. (U.S. CLS. 100, 103 AND 106). REG. 9-18-2001.
- 2,490,595. DRIVER'S WAY. INT. CL. 35. (U.S. CLS. 100, 101 AND 102). REG. 9-18-2001.
- 2,490,622. STRAP MATE. INT. CL. 19. (U.S. CLS. 1, 12, 33 AND 50). REG. 9-18-2001.
- 2,490,842. GC AND DESIGN. INT. CLS. 35, 40 AND 42. (U.S. CLS. 100, 101, 102, 103 AND 106). REG. 9-18-2001.
- 2,490,918. DURACRAFT. INT. CL. 8. (U.S. CLS. 23, 28 AND 44). REG. 9-18-2001.
- 2,491,099. SUN CAPITAL INVESTMENT GRADE BOND FUND. INT. CL. 36. (U.S. CLS. 100, 101 AND 102). REG. 9-18-2001.
- 2,491,698. MALIBU DREAM GIRL. INT. CL. 25. (U.S. CLS. 22 AND 39). REG. 9-25-2001.
- 2,491,724. MISCELLANEOUS DESIGN. INT. CL. 18. (U.S. CLS. 1, 2, 3, 22 AND 41). REG. 9-25-2001.
- 2,491,872. D.A.R.E. INTERNATIONAL. INT. CLS. 6 AND 14. (U.S. CLS. 2, 12, 13, 14, 23, 25, 27, 28 AND 50). REG. 9-25-2001.
- 2,492,030. NIVEA BODY AND DESIGN. INT. CL. 3. (U.S. CLS. 1, 4, 6, 50, 51 AND 52). REG. 9-25-2001.
- 2,492,351. FREEZ WAY. INT. CL. 32. (U.S. CLS. 45, 46 AND 48). REG. 9-25-2001.
- 2,492,438. AQUANOR. INT. CL. 29. (U.S. CL. 46). REG. 9-25-2001.
- 2,492,640. ULTRAFLEX. INT. CL. 11. (U.S. CLS. 13, 21, 23, 31 AND 34). REG. 9-25-2001.
- 2,492,718. ITI AND DESIGN. INT. CL. 7. (U.S. CLS. 13, 19, 21, 23, 31, 34 AND 35). REG. 9-25-2001.
- 2,493,182. XLERATOR PERFORMANCE EXHAUST (STYLIZED). INT. CL. 12. (U.S. CLS. 19, 21, 23, 31, 35 AND 44). REG. 9-25-2001.
- 2,493,252. PEOPLEPC. INT. CL. 35. (U.S. CLS. 100, 101 AND 102). REG. 9-25-2001.
- 2,494,202. GO WITH A PRO (STYLIZED). INT. CL. 39. (U.S. CLS. 100 AND 105). REG. 10-2-2001.
- 2,494,302. NATIONWIDE. INT. CL. 9. (U.S. CLS. 21, 23, 26, 36 AND 38). REG. 10-2-2001.
- 2,494,529. LOX-RUST. INT. CL. 2. (U.S. CLS. 6, 11 AND 16). REG. 10-2-2001.
- 2,494,591. EGS. INT. CLS. 9 AND 11. (U.S. CLS. 13, 21, 23, 26, 31, 34, 36 AND 38). REG. 10-2-2001.
- 2,495,599. POCAHONTAS. INT. CLS. 29, 30 AND 32 ONLY. (U.S. CLS. 45, 46 AND 48). REG. 10-9-2001.
- 2,496,014. DWAFFLER. INT. CL. 9. (U.S. CLS. 21, 23, 26, 36 AND 38). REG. 10-9-2001.
- 2,496,508. PRODUCTIVITY EDGE. INT. CLS. 35, 36 AND 42. (U.S. CLS. 100, 101 AND 102). REG. 10-9-2001.
- 2,496,620. CITY OF IDEAS. INT. CLS. 25 AND 35 ONLY. (U.S. CLS. 22, 39, 100, 101 AND 102). REG. 10-9-2001.
- 2,497,093. BIRTHMOTHERS AND DESIGN. INT. CL. 16. (U.S. CLS. 2, 5, 22, 23, 29, 37, 38 AND 50). REG. 10-9-2001.
- 2,497,221. MORMATE. INT. CL. 1. (U.S. CLS. 1, 5, 6, 10, 26 AND 46). REG. 10-9-2001.
- 2,497,287. HEALTHY PET. INT. CL. 16. (U.S. CLS. 2, 5, 22, 23, 29, 37, 38 AND 50). REG. 10-9-2001.
- 2,498,159. SERIOUS BUSINESS. INT. CL. 35. (U.S. CLS. 100, 101 AND 102). REG. 10-16-2001.
- 2,498,613. LEROY HILL COFFEE COMPANY, INC.. INT. CLS. 29 AND 30. (U.S. CL. 46). REG. 10-16-2001.
- 2,498,742. CSA DESIGN CERTIFIED AND DESIGN. U.S. CL. A. REG. 10-16-2001.
- 2,499,618. WOMEN' S HEALTH MONITOR. INT. CL. 16. (U.S. CLS. 2, 5, 22, 23, 29, 37, 38 AND 50). REG. 10-23-2001.
- 2,500,136. VIROSOFT. INT. CL. 5. (U.S. CLS. 6, 18, 44, 46, 51 AND 52). REG. 10-23-2001.
- 2,500,734. AJI ICHIBAN AND DESIGN. INT. CL. 29. (U.S. CL. 46). REG. 10-23-2001.
- 2,500,741. LEMON ZEST. INT. CL. 29. (U.S. CL. 46). REG. 10-23-2001.
- 2,500,824. MISCELLANEOUS DESIGN. INT. CL. 30. (U.S. CL. 46). REG. 10-23-2001.
- 2,501,252. SERRV INTERNATIONAL. INT. CL. 42. (U.S. CLS. 100 AND 101). REG. 10-30-2001.
- 2,501,345. SPONGESOIL. INT. CL. 1. (U.S. CLS. 1, 5, 6, 10, 26 AND 46). REG. 10-30-2001.
- 2,501,407. ARTHRITIS HEALTH MONITOR. INT. CL. 16. (U.S. CLS. 2, 5, 22, 23, 29, 37, 38 AND 50). REG. 10-30-2001.
- 2,502,672. COLORCLEAR. INT. CL. 1. (U.S. CLS. 1, 5, 6, 10, 26 AND 46). REG. 10-30-2001.
- 2,503,076. PARAPHRASE. INT. CL. 25. (U.S. CLS. 22 AND 39). REG. 10-30-2001.
- 2,503,982. KIDZVILLE. INT. CL. 41. (U.S. CLS. 100, 101 AND 107). REG. 11-6-2001.
- 2,504,409. ADESA AND DESIGN. INT. CL. 35. (U.S. CLS. 100, 101 AND 102). REG. 11-6-2001.
- 2,504,410. MISCELLANEOUS DESIGN. INT. CL. 35. (U.S. CLS. 100, 101 AND 102). REG. 11-6-2001.
- 2,504,696. FLUKEVIEW. INT. CL. 9. (U.S. CLS. 21, 23, 26, 36 AND 38). REG. 11-6-2001.
- 2,505,554. WOW COW. INT. CL. 30. (U.S. CL. 46). REG. 11-6-2001.

- 2,505,839. THE COMPUTER GUYS. INT. CL. 41. (U.S. CLS. 100, 101 AND 107). REG. 11-13-2001.
- 2,506,105. ORO DE DIOS (STYLIZED). INT. CL. 14. (U.S. CLS. 2, 27, 28 AND 50). REG. 11-13-2001.
- 2,506,388. OLIVER CONTI. INT. CL. 33. (U.S. CLS. 47 AND 49). REG. 11-13-2001.
- 2,506,469. MISCELLANEOUS DESIGN. INT. CL. 19. (U.S. CLS. 1, 12, 33 AND 50). REG. 11-13-2001.
- 2,506,947. NORTHERN CROSS. INT. CL. 37. (U.S. CLS. 100, 103 AND 106). REG. 11-13-2001.
- 2,507,016. OLATHE BOOT COMPANY. INT. CL. 25. (U.S. CLS. 22 AND 39). REG. 11-13-2001.
- 2,507,961. PETITE FAVORITES. INT. CL. 29. (U.S. CL. 46). REG. 11-13-2001.
- 2,508,954. HOME CENTER AND DESIGN. INT. CL. 35. (U.S. CLS. 100, 101 AND 102). REG. 11-20-2001.
- 2,509,305. STUSSY. INT. CL. 5. (U.S. CLS. 6, 18, 44, 46, 51 AND 52). REG. 11-20-2001.
- 2,509,356. IRONWOOD CAPITAL. INT. CL. 36. (U.S. CLS. 100, 101 AND 102). REG. 11-20-2001.
- 2,509,640. JOBLEADERS. INT. CL. 16. (U.S. CLS. 2, 5, 22, 23, 29, 37, 38 AND 50). REG. 11-20-2001.
- 2,509,769. RITZCAMERA.COM. INT. CL. 35. (U.S. CLS. 100, 101 AND 102). REG. 11-20-2001.
- 2,509,881. THE SMART ALTERNATIVE. INT. CL. 39. (U.S. CLS. 100 AND 105). REG. 11-20-2001.
- 2,509,970. OUR PASSION IS BUILDING. INT. CL. 37. (U.S. CLS. 100, 103 AND 106). REG. 11-20-2001.
- 2,510,528. REMARKABLE. INT. CL. 3. (U.S. CLS. 1, 4, 6, 50, 51 AND 52). REG. 11-20-2001.
- 2,510,956. NEW CENTURY COLA. INT. CL. 32. (U.S. CLS. 45, 46 AND 48). REG. 11-20-2001.
- 2,511,061. FAYRE. INT. CL. 29. (U.S. CL. 46). REG. 11-20-2001.
- 2,511,494. TRACTION BAR. INT. CL. 7. (U.S. CLS. 13, 19, 21, 23, 31, 34 AND 35). REG. 11-27-2001.
- 2,511,617. LEADING RESOURCES. INT. CL. 35. (U.S. CLS. 100, 101 AND 102). REG. 11-27-2001.
- 2,511,832. PATENTUSA. INT. CL. 42. (U.S. CLS. 100 AND 101). REG. 11-27-2001.
- 2,511,868. PLYMOUTH FORGE. INT. CL. 8. (U.S. CLS. 23, 28 AND 44). REG. 11-27-2001.
- 2,512,276. SOUND RX. INT. CL. 9. (U.S. CLS. 21, 23, 26, 36 AND 38). REG. 11-27-2001.
- 2,512,622. XCOATING (STYLIZED). INT. CL. 10. (U.S. CLS. 26, 39 AND 44). REG. 11-27-2001.
- 2,513,380. ANTHEM. INT. CL. 7. (U.S. CLS. 13, 19, 21, 23, 31, 34 AND 35). REG. 11-27-2001.
- 2,513,843. CONTACT BAR. INT. CL. 7. (U.S. CLS. 13, 19, 21, 23, 31, 34 AND 35). REG. 12-4-2001.
- 2,513,966. BARRACUDA. INT. CL. 8. (U.S. CLS. 23, 28 AND 44). REG. 12-4-2001.
- 2,514,158. THOMPSON & MORGAN. INT. CL. 31. (U.S. CLS. 1 AND 46). REG. 12-4-2001.
- 2,514,199. FIT TO FLY. INT. CL. 18. (U.S. CLS. 1, 2, 3, 22 AND 41). REG. 12-4-2001.
- 2,514,905. DAK INDUSTRIES. INT. CL. 35. (U.S. CLS. 100, 101 AND 102). REG. 12-4-2001.
- 2,514,942. DK AND DESIGN. INT. CL. 35. (U.S. CLS. 100, 101 AND 102). REG. 12-4-2001.
- 2,516,839. GST MAPPER. INT. CL. 9. (U.S. CLS. 21, 23, 26, 36 AND 38). REG. 12-11-2001.
- 2,516,875. TIME VALUE OF MONEY. INT. CL. 36. (U.S. CLS. 100, 101 AND 102). REG. 12-11-2001.
- 2,517,054. DELPHI. INT. CL. 19. (U.S. CLS. 1, 12, 33 AND 50). REG. 12-11-2001.
- 2,517,055. PHOENIX. INT. CL. 19. (U.S. CLS. 1, 12, 33 AND 50). REG. 12-11-2001.
- 2,517,056. LYDIAN. INT. CL. 19. (U.S. CLS. 1, 12, 33 AND 50). REG. 12-11-2001.
- 2,517,071. ALCOR. INT. CL. 42. (U.S. CLS. 100 AND 101). REG. 12-11-2001.
- 2,517,600. BOSS. INT. CLS. 21, 24 AND 25. (U.S. CLS. 2, 13, 22, 23, 29, 30, 33, 39, 40, 42 AND 50). REG. 12-11-2001.
- 2,517,606. MONTICELLO. INT. CL. 20. (U.S. CLS. 2, 13, 22, 25, 32 AND 50). REG. 12-11-2001.
- 2,519,482. ARIZONA TILE AND DESIGN. INT. CL. 19. (U.S. CLS. 1, 12, 33 AND 50). REG. 12-18-2001.
- 2,520,383. DENTYNE ICE. INT. CL. 30. (U.S. CL. 46). REG. 12-18-2001.
- 2,520,528. CSR. INT. CL. 9. (U.S. CLS. 21, 23, 26, 36 AND 38). REG. 12-18-2001.
- 2,520,739. SANSCAPE. INT. CL. 9. (U.S. CLS. 21, 23, 26, 36 AND 38). REG. 12-18-2001.
- 2,522,394. TRUTHORIES. INT. CL. 16. (U.S. CLS. 2, 5, 22, 23, 29, 37, 38 AND 50). REG. 12-25-2001.
- 2,523,190. DNASPACE. INT. CL. 9. (U.S. CLS. 21, 23, 26, 36 AND 38). REG. 12-25-2001.
- 2,523,358. IDX. INT. CL. 20. (U.S. CLS. 2, 13, 22, 25, 32 AND 50). REG. 12-25-2001.
- 2,523,854. AU PAIN DORE. INT. CL. 35 ONLY. (U.S. CLS. 100, 101 AND 102). REG. 1-1-2002.
- 2,524,570. KRESSMANN-BACKMEYER AND DESIGN. INT. CL. 16. (U.S. CLS. 2, 5, 22, 23, 29, 37, 38 AND 50). REG. 1-1-2002.
- 2,524,772. ATHENIAN. INT. CL. 19. (U.S. CLS. 1, 12, 33 AND 50). REG. 1-1-2002.
- 2,525,380. MED-E.R.R.S.. INT. CL. 35. (U.S. CLS. 100, 101 AND 102). REG. 1-1-2002.
- 2,526,851. TECTRON AND DESIGN. INT. CL. 8. (U.S. CLS. 23, 28 AND 44). REG. 1-8-2002.
- 2,527,750. ACT. INT. CL. 7. (U.S. CLS. 13, 19, 21, 23, 31, 34 AND 35). REG. 1-8-2002.
- 2,528,434. SKINMILK. INT. CL. 3. (U.S. CLS. 1, 4, 6, 50, 51 AND 52). REG. 1-8-2002.
- 2,530,592. PD PAUL DAVIS RESTORATION AND DESIGN. INT. CL. 35. (U.S. CLS. 100, 101 AND 102). REG. 1-15-2002.
- 2,530,759. LEGENDS. INT. CL. 41. (U.S. CLS. 100, 101 AND 107). REG. 1-15-2002.
- 2,531,099. MEDIABASE 24-7. INT. CL. 35. (U.S. CLS. 100, 101 AND 102). REG. 1-22-2002.
- 2,531,474. DTANK (STYLIZED). INT. CLS. 37 AND 42. (U.S. CLS. 100, 101, 103 AND 106). REG. 1-22-2002.
- 2,531,648. DREAMLAND BAR B QUE R I B S "AIN'T NOTHING LIKE'EM-NOWHERE" AND DESIGN. INT. CL. 42. (U.S. CLS. 100 AND 101). REG. 1-22-2002.
- 2,531,803. ZIPTINT. INT. CL. 1. (U.S. CLS. 1, 5, 6, 10, 26 AND 46). REG. 1-22-2002.
- 2,531,814. CLOROX. INT. CL. 5. (U.S. CLS. 6, 18, 44, 46, 51 AND 52). REG. 1-22-2002.
- 2,531,857. USVP. INT. CL. 36. (U.S. CLS. 100, 101 AND 102). REG. 1-22-2002.
- 2,532,461. TRIPLCOAT. INT. CL. 3. (U.S. CLS. 1, 4, 6, 50, 51 AND 52). REG. 1-22-2002.
- 2,533,009. LEXINGTON LEGENDS. INT. CL. 41. (U.S. CLS. 100, 101 AND 107). REG. 1-22-2002.
- 2,534,168. SAN ANTONIO SPURS AND DESIGN. INT. CL. 35. (U.S. CLS. 100, 101 AND 102). REG. 1-29-2002.
- 2,534,202. MINKUS AND DESIGN. INT. CL. 16. (U.S. CLS. 2, 5, 22, 23, 29, 37, 38 AND 50). REG. 1-29-2002.
- 2,534,407. L'IL DAVINCI. INT. CL. 20. (U.S. CLS. 2, 13, 22, 25, 32 AND 50). REG. 1-29-2002.
- 2,535,011. E-FAQ. INT. CL. 9. (U.S. CLS. 21, 23, 26, 36 AND 38). REG. 1-29-2002.
- 2,535,259. MISCELLANEOUS DESIGN. INT. CL. 30. (U.S. CL. 46). REG. 2-5-2002.
- 2,535,875. U.S. EGG. INT. CL. 42. (U.S. CLS. 100 AND 101). REG. 2-5-2002.
- 2,536,824. BENT WILLEY'S. INT. CL. 42. (U.S. CLS. 100 AND 101). REG. 2-5-2002.
- 2,538,095. MISCELLANEOUS DESIGN. INT. CL. 5. (U.S. CLS. 6, 18, 44, 46, 51 AND 52). REG. 2-12-2002.
- 2,540,362. MISCELLANEOUS DESIGN. INT. CLS. 35, 37 AND 42. (U.S. CLS. 100, 101, 102, 103 AND 106). REG. 2-19-2002.
- 2,540,480. CONSISTENT PHILOSOPHY. CONSISTENT APPROACH. CONSISTENT RESULTS. INT. CL. 36. (U.S. CLS. 100, 101 AND 102). REG. 2-19-2002.
- 2,540,523. MISCELLANEOUS DESIGN. INT. CL. 28. (U.S. CLS. 22, 23, 38 AND 50). REG. 2-19-2002.
- 2,540,631. IDEX STANDARD CHARACTER MARK. INT. CL. 42. (U.S. CLS. 100 AND 101). REG. 2-19-2002.
- 2,540,656. SINGLE SOURCE ROOFING. INT. CLS. 19, 37 AND 42. (U.S. CLS. 1, 12, 33, 50, 100, 101, 103 AND 106). REG. 2-19-2002.
- 2,541,872. THE PROFESSIONAL'S CHOICE. INT. CL. 11. (U.S. CLS. 13, 21, 23, 31 AND 34). REG. 2-19-2002.
- 2,542,956. KITCHEN SOLVERS. INT. CL. 37. (U.S. CLS. 100, 103 AND 106). REG. 2-26-2002.
- 2,543,216. TIME OUT. INT. CL. 35. (U.S. CLS. 100, 101 AND 102). REG. 2-26-2002.
- 2,543,217. TIME OUT AND DESIGN. INT. CL. 35. (U.S. CLS. 100, 101 AND 102). REG. 2-26-2002.
- 2,543,417. CUPIDON AND DESIGN. INT. CL. 41. (U.S. CLS. 100, 101 AND 107). REG. 2-26-2002.
- 2,544,636. MIGHTY LEAF TEA AND DESIGN. INT. CL. 30. (U.S. CL. 46). REG. 3-5-2002.

- 2,545,750. ADVISOR TODAY. INT. CL. 16. (U.S. CLS. 2, 5, 22, 23, 29, 37, 38 AND 50). REG. 3-12-2002.
- 2,546,009. DATA911. INT. CL. 9. (U.S. CLS. 21, 23, 26, 36 AND 38). REG. 3-12-2002.
- 2,546,193. HARU AND DESIGN. INT. CL. 42. (U.S. CLS. 100 AND 101). REG. 3-12-2002.
- 2,546,556. ZEIGLER. INT. CL. 31. (U.S. CLS. 1 AND 46). REG. 3-12-2002.
- 2,548,017. Y AND DESIGN. INT. CL. 6. (U.S. CLS. 2, 12, 13, 14, 23, 25 AND 50). REG. 3-12-2002.
- 2,548,069. DIXON HOUSE. INT. CLS. 29 AND 30. (U.S. CL. 46). REG. 3-12-2002.
- 2,548,840. OASIS CAR WASH AND DESIGN. INT. CL. 37. (U.S. CLS. 100, 103 AND 106). REG. 3-19-2002.
- 2,549,368. NAMESECURE. INT. CLS. 38 AND 42. (U.S. CLS. 100, 101 AND 104). REG. 3-19-2002.
- 2,549,370. CEO AND DESIGN. INT. CL. 42. (U.S. CLS. 100 AND 101). REG. 3-19-2002.
- 2,551,747. ENZYMALL. INT. CL. 5. (U.S. CLS. 6, 18, 44, 46, 51 AND 52). REG. 3-26-2002.
- 2,551,748. SUPER ENZYMALL. INT. CL. 5. (U.S. CLS. 6, 18, 44, 46, 51 AND 52). REG. 3-26-2002.
- 2,552,095. THE LIFE ENJOYMENT EXPERIENCE. INT. CL. 36. (U.S. CLS. 100, 101 AND 102). REG. 3-26-2002.
- 2,553,020. ACCU-LOC. INT. CL. 7. (U.S. CLS. 13, 19, 21, 23, 31, 34 AND 35). REG. 3-26-2002.
- 2,554,453. JOURNEY TO ATLANTIS AND DESIGN. INT. CL. 41. (U.S. CLS. 100, 101 AND 107). REG. 4-2-2002.
- 2,554,518. GOOGLES. INT. CL. 28. (U.S. CLS. 22, 23, 38 AND 50). REG. 4-2-2002.
- 2,555,264. A (STYLIZED). INT. CL. 29. (U.S. CL. 46). REG. 4-2-2002.
- 2,555,369. PRN FUNDING. INT. CL. 36. (U.S. CLS. 100, 101 AND 102). REG. 4-2-2002.
- 2,555,483. ET ODYSSEY AND DESIGN. INT. CLS. 39 AND 42. (U.S. CLS. 100, 101 AND 105). REG. 4-2-2002.
- 2,555,699. SAA (STYLIZED). INT. CL. 41. (U.S. CLS. 100, 101 AND 107). REG. 4-2-2002.
- 2,556,986. ROXY. INT. CL. 30. (U.S. CL. 46). REG. 4-2-2002.
- 2,557,983. COYOTE CREEK. INT. CL. 33. (U.S. CLS. 47 AND 49). REG. 4-9-2002.
- 2,559,774. NELSON PEDIATRIC THERAPY AND DESIGN. INT. CL. 42. (U.S. CLS. 100 AND 101). REG. 4-9-2002.
- 2,561,633. DFY IT DRUG FREE YOUTH IN TOWN AND DESIGN. INT. CL. 42. (U.S. CLS. 100 AND 101). REG. 4-16-2002.
- 2,562,037. NEWTON-WELLESLEY HOSPITAL. INT. CL. 42. (U.S. CLS. 100 AND 101). REG. 4-16-2002.
- 2,562,928. SIGNATURE SERIES. INT. CLS. 6 AND 7. (U.S. CLS. 2, 12, 13, 14, 19, 21, 23, 25, 31, 34, 35 AND 50). REG. 4-23-2002.
- 2,563,330. HABERSHAM. INT. CL. 6. (U.S. CLS. 2, 12, 13, 14, 23, 25 AND 50). REG. 4-23-2002.
- 2,563,402. MEMBER'S CHOICE. INT. CL. 36. (U.S. CLS. 100, 101 AND 102). REG. 4-23-2002.
- 2,563,632. LSAC. INT. CLS. 41 AND 42. (U.S. CLS. 100, 101 AND 107). REG. 4-23-2002.
- 2,563,699. MATCHBOX TWENTY. INT. CL. 41. (U.S. CLS. 100, 101 AND 107). REG. 4-23-2002.
- 2,563,785. TRUSTED SYSTEMS. INT. CL. 9. (U.S. CLS. 21, 23, 26, 36 AND 38). REG. 4-23-2002.
- 2,564,089. RAINCHECK. INT. CL. 36. (U.S. CLS. 100, 101 AND 102). REG. 4-23-2002.
- 2,564,102. ESTRO. LOGIC (STYLIZED). INT. CL. 5. (U.S. CLS. 6, 18, 44, 46, 51 AND 52). REG. 4-23-2002.
- 2,566,489. EAGLE FIRE YOUR FIRE PROTECTION COMPANY AND DESIGN. INT. CLS. 37 AND 42. (U.S. CLS. 100, 101, 103 AND 106). REG. 5-7-2002.
- 2,566,739. SERVICESOURCE. INT. CLS. 35, 41 AND 42. (U.S. CLS. 100, 101, 102 AND 107). REG. 5-7-2002.
- 2,567,057. KLEENPAK (STYLIZED). INT. CL. 21. (U.S. CLS. 2, 13, 23, 29, 30, 33, 40 AND 50). REG. 5-7-2002.
- 2,567,194. EMERGENCY CAR DOOR UNLOCKING FREE WHEN CHILD LOCKED INSIDE AND DESIGN. INT. CL. 42. (U.S. CLS. 100 AND 101). REG. 5-7-2002.
- 2,569,879. SELECT ARTISTS ASSOCIATES. INT. CL. 41. (U.S. CLS. 100, 101 AND 107). REG. 5-14-2002.
- 2,570,280. DATACURE. INT. CL. 42. (U.S. CLS. 100 AND 101). REG. 5-14-2002.
- 2,570,306. RUDEN MCCLOSKEY. INT. CLS. 41 AND 42. (U.S. CLS. 100, 101 AND 107). REG. 5-14-2002.
- 2,571,015. MISCELLANEOUS DESIGN. INT. CLS. 16, 18, 25, 41 AND 42. (U.S. CLS. 1, 2, 3, 5, 22, 23, 29, 37, 38, 39, 41, 50, 100, 101 AND 107). REG. 5-21-2002.
- 2,571,083. MISCELLANEOUS DESIGN. INT. CL. 16. (U.S. CLS. 2, 5, 22, 23, 29, 37, 38 AND 50). REG. 5-21-2002.
- 2,571,768. PRIZM. INT. CL. 9. (U.S. CLS. 21, 23, 26, 36 AND 38). REG. 5-21-2002.
- 2,572,029. PLANALYTICS. INT. CL. 9. (U.S. CLS. 21, 23, 26, 36 AND 38). REG. 5-21-2002.
- 2,572,217. PRO POWER STEEL PIERS AND DESIGN. INT. CL. 6. (U.S. CLS. 2, 12, 13, 14, 23, 25 AND 50). REG. 5-21-2002.
- 2,572,237. MISCELLANEOUS DESIGN. INT. CL. 11. (U.S. CLS. 13, 21, 23, 31 AND 34). REG. 5-21-2002.
- 2,572,903. THE WHIMSICAL PET COMPANY. INT. CL. 35. (U.S. CLS. 100, 101 AND 102). REG. 5-28-2002.
- 2,573,215. EXPOVISION AND DESIGN. INT. CL. 35. (U.S. CLS. 100, 101 AND 102). REG. 5-28-2002.
- 2,573,216. MISCELLANEOUS DESIGN. INT. CL. 35. (U.S. CLS. 100, 101 AND 102). REG. 5-28-2002.
- 2,573,271. REVOLUTIONARY. INT. CL. 30. (U.S. CL. 46). REG. 5-28-2002.
- 2,573,906. SOLDER-IT. INT. CLS. 1 AND 8. (U.S. CLS. 1, 5, 6, 10, 23, 26, 28, 44 AND 46). REG. 5-28-2002.
- 2,574,031. SURE STEP. INT. CL. 25. (U.S. CLS. 22 AND 39). REG. 5-28-2002.
- 2,574,059. HEC AND DESIGN. INT. CL. 9. (U.S. CLS. 21, 23, 26, 36 AND 38). REG. 5-28-2002.
- 2,574,095. PAN-PRO. INT. CLS. 9 AND 42. (U.S. CLS. 21, 23, 26, 36, 38, 100 AND 101). REG. 5-28-2002.
- 2,575,006. MISCELLANEOUS DESIGN. INT. CL. 9. (U.S. CLS. 21, 23, 26, 36 AND 38). REG. 6-4-2002.
- 2,575,620. SOR.COM. INT. CL. 12. (U.S. CLS. 19, 21, 23, 31, 35 AND 44). REG. 6-4-2002.
- 2,576,067. MISCELLANEOUS DESIGN. INT. CL. 9. (U.S. CLS. 21, 23, 26, 36 AND 38). REG. 6-4-2002.
- 2,576,273. PAST BASKET. INT. CLS. 35 AND 42. (U.S. CLS. 100, 101 AND 102). REG. 6-4-2002.
- 2,576,402. M AND DESIGN. INT. CL. 32. (U.S. CLS. 45, 46 AND 48). REG. 6-4-2002.
- 2,578,320. FM 186-2. INT. CL. 3. (U.S. CLS. 1, 4, 6, 50, 51 AND 52). REG. 6-11-2002.
- 2,578,539. MISCELLANEOUS DESIGN. INT. CL. 37. (U.S. CLS. 100, 103 AND 106). REG. 6-11-2002.
- 2,578,620. GOLDLINK. INT. CL. 9. (U.S. CLS. 21, 23, 26, 36 AND 38). REG. 6-11-2002.
- 2,578,715. KOLD.TO.GO. INT. CL. 21. (U.S. CLS. 2, 13, 23, 29, 30, 33, 40 AND 50). REG. 6-11-2002.
- 2,580,665. RAINFOREST PYRAMID. INT. CL. 41. (U.S. CLS. 100, 101 AND 107). REG. 6-18-2002.
- 2,581,185. TF THE TRANEL FINANCIAL GROUP (STYLIZED). INT. CL. 36. (U.S. CLS. 100, 101 AND 102). REG. 6-18-2002.
- 2,581,380. ONE DAN BAND. INT. CL. 9. (U.S. CLS. 21, 23, 26, 36 AND 38). REG. 6-18-2002.
- 2,581,797. ULTRAFRYER. INT. CL. 11. (U.S. CLS. 13, 21, 23, 31 AND 34). REG. 6-18-2002.
- 2,581,823. M H MACKENZIE HUGHES LLP PLAIN TALK. EXCEPTIONAL EXPERTISE. AND DESIGN. INT. CL. 42. (U.S. CLS. 100 AND 101). REG. 6-18-2002.
- 2,582,279. O. INT. CL. 34. (U.S. CLS. 2, 8, 9 AND 17). REG. 6-18-2002.
- 2,582,322. HENDRICK. INT. CL. 42. (U.S. CLS. 100 AND 101). REG. 6-18-2002.
- 2,582,926. SUNSHINE DIAMOND. INT. CL. 14. (U.S. CLS. 2, 27, 28 AND 50). REG. 6-18-2002.
- 2,583,457. FOREVER 21. INT. CL. 25. (U.S. CLS. 22 AND 39). REG. 6-18-2002.
- 2,584,273. GLOBAL FINANCIAL SERVICES. INT. CL. 36. (U.S. CLS. 100, 101 AND 102). REG. 6-25-2002.
- 2,584,321. MISCELLANEOUS DESIGN. INT. CL. 20. (U.S. CLS. 2, 13, 22, 25, 32 AND 50). REG. 6-25-2002.
- 2,584,686. REFLEX ANTI-FATIGUE MATS. INT. CL. 27. (U.S. CLS. 19, 20, 37, 42 AND 50). REG. 6-25-2002.
- 2,584,706. WHITE HORSE. INT. CL. 25. (U.S. CLS. 22 AND 39). REG. 6-25-2002.
- 2,584,803. PIO Y. PARK ENTERPRISES AND DESIGN. INT. CL. 35. (U.S. CLS. 100, 101 AND 102). REG. 6-25-2002.
- 2,584,980. MORE THAN YOGA. INT. CL. 41. (U.S. CLS. 100, 101 AND 107). REG. 6-25-2002.
- 2,585,137. DEL MAR. INT. CL. 35. (U.S. CLS. 100, 101 AND 102). REG. 6-25-2002.

- 2,585,211. BRAVO TWO X. INT. CL. 7. (U.S. CLS. 13, 19, 21, 23, 31, 34 AND 35). REG. 6-25-2002.
- 2,585,212. BRAVO THREE X. INT. CL. 7. (U.S. CLS. 13, 19, 21, 23, 31, 34 AND 35). REG. 6-25-2002.
- 2,585,440. GLOBAL STEEL AND FLAMECUTTING SERVICES AND DESIGN. INT. CL. 40. (U.S. CLS. 100, 103 AND 106). REG. 6-25-2002.
- 2,585,664. M AND DESIGN. INT. CL. 12. (U.S. CLS. 19, 21, 23, 31, 35 AND 44). REG. 6-25-2002.
- 2,586,378. DYNAFIND. INT. CL. 9. (U.S. CLS. 21, 23, 26, 36 AND 38). REG. 6-25-2002.
- 2,586,995. MISSOURI HEART CENTER. INT. CL. 42. (U.S. CLS. 100 AND 101). REG. 6-25-2002.
- 2,586,996. MATHFACTS. INT. CL. 41. (U.S. CLS. 100, 101 AND 107). REG. 6-25-2002.
- 2,587,198. J J HOOKS. INT. CL. 19. (U.S. CLS. 1, 12, 33 AND 50). REG. 7-2-2002.
- 2,587,843. SUKI HANA AND DESIGN. INT. CL. 42. (U.S. CLS. 100 AND 101). REG. 7-2-2002.
- 2,587,855. NH&RA. INT. CL. 42. (U.S. CLS. 100 AND 101). REG. 7-2-2002.
- 2,588,033. ALASKA STOCK IMAGES. INT. CL. 42. (U.S. CLS. 100 AND 101). REG. 7-2-2002.
- 2,588,285. GRANDPA'S COUNTRY FRIED BREAKFAST. INT. CL. 29. (U.S. CL. 46). REG. 7-2-2002.
- 2,588,645. PATRIOT OF AMERICA. INT. CL. 20. (U.S. CLS. 2, 13, 22, 25, 32 AND 50). REG. 7-2-2002.
- 2,588,646. PRIDE OF AMERICA. INT. CL. 20. (U.S. CLS. 2, 13, 22, 25, 32 AND 50). REG. 7-2-2002.
- 2,588,800. PEOPLEMETRICS. INT. CL. 35. (U.S. CLS. 100, 101 AND 102). REG. 7-2-2002.
- 2,589,678. EMBRACE. INT. CL. 31. (U.S. CLS. 1 AND 46). REG. 7-2-2002.
- 2,589,730. XACTSCOPE. INT. CL. 9. (U.S. CLS. 21, 23, 26, 36 AND 38). REG. 7-2-2002.
- 2,590,063. HR ASSESSMENTS. INT. CL. 16 ONLY. (U.S. CLS. 2, 5, 22, 23, 29, 37, 38 AND 50). REG. 7-2-2002.
- 2,590,414. DIGNITY MEMORIAL. INT. CLS. 36 AND 42. (U.S. CLS. 100, 101 AND 102). REG. 7-9-2002.
- 2,590,577. GUEST CONNECTIONS. INT. CL. 38. (U.S. CLS. 100, 101 AND 104). REG. 7-9-2002.
- 2,590,696. FRIENDS OF NRA AND DESIGN. INT. CL. 42. (U.S. CLS. 100 AND 101). REG. 7-9-2002.
- 2,590,850. MISCELLANEOUS DESIGN. INT. CL. 42. (U.S. CLS. 100 AND 101). REG. 7-9-2002.
- 2,590,851. HANNAH'S HOME. INT. CL. 42. (U.S. CLS. 100 AND 101). REG. 7-9-2002.
- 2,590,891. PERKIOMEN VALLEY CHAMBER OF COMMERCE AND DESIGN. INT. CL. 35. (U.S. CLS. 100, 101 AND 102). REG. 7-9-2002.
- 2,591,082. CALIFORNIA OVERNIGHT. INT. CL. 39. (U.S. CLS. 100 AND 105). REG. 7-9-2002.
- 2,591,488. DEAN. INT. CL. 11. (U.S. CLS. 13, 21, 23, 31 AND 34). REG. 7-9-2002.
- 2,591,496. N S E W MIDWESTERN AND DESIGN. INT. CL. 7. (U.S. CLS. 13, 19, 21, 23, 31, 34 AND 35). REG. 7-9-2002.
- 2,591,545. DOCUBLOCK. INT. CL. 35. (U.S. CLS. 100, 101 AND 102). REG. 7-9-2002.
- 2,591,664. RMP. U.S. CL. B. REG. 7-9-2002.
- 2,591,762. ZOONIVERSITY. INT. CL. 41. (U.S. CLS. 100, 101 AND 107). REG. 7-9-2002.
- 2,591,947. BIRTHDAY WISHES. INT. CL. 28. (U.S. CLS. 22, 23, 38 AND 50). REG. 7-9-2002.
- 2,592,117. OBSEQUIO. INT. CL. 34. (U.S. CLS. 2, 8, 9 AND 17). REG. 7-9-2002.
- 2,592,654. SCHOLASTIC AND DESIGN. INT. CL. 28. (U.S. CLS. 22, 23, 38 AND 50). REG. 7-9-2002.
- 2,592,993. SERAFINA. INT. CL. 28. (U.S. CLS. 22, 23, 38 AND 50). REG. 7-9-2002.
- 2,593,154. RETAIL GROUP OF NEW YORK. INT. CL. 35. (U.S. CLS. 100, 101 AND 102). REG. 7-9-2002.
- 2,593,155. WHOLESALE GROUP OF NEW YORK. INT. CL. 35. (U.S. CLS. 100, 101 AND 102). REG. 7-9-2002.
- 2,593,294. LITHIUMPOWER. INT. CL. 9. (U.S. CLS. 21, 23, 26, 36 AND 38). REG. 7-9-2002.
- 2,595,910. TYPHOON. INT. CL. 5. (U.S. CLS. 6, 18, 44, 46, 51 AND 52). REG. 7-16-2002.
- 3,390,481. ASSOULINE. INT. CLS. 16, 35 AND 41. (U.S. CLS. 2, 5, 22, 23, 29, 37, 38, 50, 100, 101, 102 AND 107). REG. 6-12-2001.

* * * * *

TRADEMARK REGISTRATIONS CANCELED

The designation "U.S. Cl." appearing in this section refers to the U.S. class in effect prior to Sep. 1, 1973 rather than the international class which applies to applications filed on or after that date. For adoption of international classification see notice in the OFFICIAL GAZETTE of Jun. 26, 1973 (911 O.G. TM 210).

SECTION 7(D)

- 732,817. GAINES.BURGERS. U.S. CL. 46. REG. 6-12-1962.
1,532,714. JACOBS WIND ENERGY SYSTEMS AND DESIGN. INT. CL. 7. REG. 4-4-1989.
2,552,204. BWA BATTERED WOMEN'S ALTERNATIVES. INT. CL. 42. REG. 3-26-2002.
2,900,109. DOMAINDOMAIN.COM AND DESIGN. INT. CL. 42. REG. 11-2-2004.
2,914,146. T-MOBILE WIRELESS BROADBAND. INT. CLS. 9, 16, 35, 36, 38, 39, 41 AND 42. REG. 12-28-2004.
2,914,539. MISCELLANEOUS DESIGN. INT. CL. 16. REG. 12-28-2004.
2,931,359. THE OUTDOORSMAN. INT. CL. 11. REG. 3-8-2005.
2,958,134. MBP. INT. CL. 41 ONLY. REG. 5-31-2005.
3,140,276. LIFT AND TUCK STANDARD CHARACTER MARK. INT. CL. 3. REG. 9-5-2006.
3,141,850. RISKASSIST STANDARD CHARACTER MARK. INT. CLS. 16, 35 AND 36. REG. 9-12-2006.
3,191,436. OK! FIRST FOR CELEBRITY NEWS AND DESIGN. INT. CL. 16. REG. 1-2-2007.
3,210,462. OK! FIRST FOR CELEBRITY NEWS AND DESIGN. INT. CLS. 9 AND 41. REG. 2-20-2007.
3,407,027. SOFIA AND DESIGN. INT. CL. 29. REG. 4-1-2008.
3,441,077. JAKAVI STANDARD CHARACTER MARK. INT. CL. 5. REG. 6-3-2008.
3,491,038. BUSINESS IN MOTION STANDARD CHARACTER MARK. INT. CLS. 9 AND 38. REG. 8-26-2008.
3,635,447. G-WORK STANDARD CHARACTER MARK. INT. CLS. 35 AND 36 ONLY. REG. 6-9-2009.
3,752,376. MEMO STANDARD CHARACTER MARK. INT. CL. 25 ONLY. REG. 2-23-2010.
3,859,223. BELLA ZADORE AND DESIGN. INT. CL. 25. REG. 10-12-2010.
3,882,700. MY-VALE STANDARD CHARACTER MARK. INT. CL. 9 ONLY. REG. 11-30-2010.
3,902,533. EUROGAS STANDARD CHARACTER MARK. INT. CL. 42. REG. 1-11-2011.
1,627,128. LUC BERJEN. INT. CLS. 18 AND 25. REG. 12-11-1990.
1,627,859. BOZZINI (STYLIZED). INT. CLS. 3, 16 AND 18. REG. 12-11-1990.
1,627,946. BOLT ENERGY. INT. CL. 5. REG. 12-18-1990.
1,650,596. MISCELLANEOUS DESIGN. INT. CLS. 8 AND 26 ONLY. REG. 7-16-1991.
1,654,202. S (STYLIZED). INT. CLS. 16 AND 42 ONLY. REG. 8-20-1991.
1,789,241. PHOTOMOTION. INT. CLS. 9 AND 16. REG. 8-24-1993.
1,801,986. EDGE. INT. CL. 10. REG. 11-2-1993.
1,939,524. H HALOX HALOX "BETTER HEALTH THROUGH BETTER WATER" AND DESIGN. INT. CL. 5. REG. 12-5-1995.
1,975,355. PLATE MASTER. INT. CL. 20. REG. 5-21-1996.
1,991,384. FSI AND DESIGN. INT. CL. 37. REG. 8-6-1996.
2,002,953. MAYBELLINE. INT. CLS. 8, 16, 18, 21 AND 25. REG. 9-24-1996.
2,015,371. CHEVAL AND DESIGN. INT. CLS. 35 AND 37. REG. 11-12-1996.
2,038,469. STOP IT SMOKING (STYLIZED). INT. CL. 5. REG. 2-18-1997.
2,090,402. THETA TAU (STYLIZED). U.S. CL. 200. REG. 8-26-1997.
2,110,882. THIRST QUENCHERS. INT. CL. 21. REG. 11-4-1997.
2,113,921. ESSENTIALDENTAL. INT. CL. 36. REG. 11-18-1997.
2,126,710. CEP. INT. CL. 41. REG. 1-6-1998.
2,141,136. VIDJEWEL SPORTS. INT. CL. 16. REG. 3-3-1998.
2,150,965. FUNNY SHAPES. INT. CL. 16. REG. 4-14-1998.
2,162,395. COLOR ME AND LEARN. INT. CL. 16. REG. 6-2-1998.
2,229,607. LUCID * AND DESIGN. INT. CL. 25. REG. 3-2-1999.
2,303,767. DEVELOPMENTOR. INT. CL. 25. REG. 12-28-1999.
2,320,319. VARILOC. INT. CL. 7. REG. 2-22-2000.
2,385,693. PRESQUE ISLE PILSNER. INT. CL. 32. REG. 9-12-2000.
2,385,782. VIRTUAL GEO. INT. CL. 25. REG. 9-12-2000.
2,409,120. MAISON DECOR AND DESIGN. INT. CLS. 20 AND 42. REG. 11-28-2000.
2,410,519. SWANNNDRI. INT. CL. 25. REG. 12-5-2000.
2,411,625. HYPERION. INT. CL. 35. REG. 12-12-2000.
2,411,631. ENVISION AND DESIGN. INT. CLS. 16 AND 36. REG. 12-12-2000.
2,411,635. 5380 D.P.. INT. CLS. 1 AND 2. REG. 12-12-2000.
2,411,638. LAUNDRY BY SHELLI SEGAL. INT. CL. 25. REG. 12-12-2000.
2,411,642. GIBBON. INT. CL. 2. REG. 12-12-2000.
2,411,643. MISCELLANEOUS DESIGN. INT. CL. 6. REG. 12-12-2000.
2,411,651. LAST MILE SOLUTION. INT. CL. 38. REG. 12-12-2000.
2,411,661. NORMAN (STYLIZED). INT. CLS. 9, 16, 35, 36, 37, 41 AND 42. REG. 12-12-2000.
2,411,672. VISUAL RATE MODELER. INT. CL. 9. REG. 12-12-2000.
2,411,675. SOONER OR LATER EVERY HOME WILL HAVE IT. INT. CLS. 35 AND 37. REG. 12-12-2000.
2,411,681. ISSO OF CHICAGO AND DESIGN. INT. CLS. 41 AND 42. REG. 12-12-2000.

SECTION 8

- 1,127,412. PMC INDUSTRIES AND DESIGN. INT. CL. 7. REG. 12-11-1979.
1,127,460. SPARKOMATIC (STYLIZED). INT. CLS. 9 AND 14. REG. 12-11-1979.
1,127,554. KORET (STYLIZED). INT. CL. 25. REG. 12-11-1979.
1,143,571. KOO KOOS. INT. CL. 30. REG. 12-16-1980.
1,186,186. HEAVEN. INT. CL. 42. REG. 1-12-1982.
1,189,727. WALT DISNEY WORLD. INT. CLS. 9, 11, 18 AND 20 ONLY. REG. 2-16-1982.
1,613,055. CYBERPUNK. INT. CL. 28. REG. 9-11-1990.
1,626,659. HAWA AND DESIGN. INT. CLS. 6, 9 AND 20. REG. 12-11-1990.

- 2,411,694. INDEXONE. INT. CL. 36. REG. 12-12-2000.
 2,411,697. 1-888-OE-PARTS. INT. CL. 42. REG. 12-12-2000.
 2,411,709. POLICE EXECUTIVE RESEARCH FORUM AND DESIGN. INT. CL. 41. REG. 12-12-2000.
 2,411,711. BIOTECH. INT. CL. 5. REG. 12-12-2000.
 2,411,718. ATHENIAN AND DESIGN. INT. CL. 30. REG. 12-12-2000.
 2,411,720. TSA TECHNOLOGY STUDENT ASSOCIATION AND DESIGN. INT. CL. 41. REG. 12-12-2000.
 2,411,736. PERFECT BUILDING SYSTEM SUPER BLOCK. INT. CL. 19. REG. 12-12-2000.
 2,411,746. PUBLIC MEDIA CENTER. INT. CLS. 35, 36, 41 AND 42. REG. 12-12-2000.
 2,411,768. IN 21 DAYS AND DESIGN. INT. CL. 16. REG. 12-12-2000.
 2,411,770. REDDY FLAME. INT. CL. 39. REG. 12-12-2000.
 2,411,772. HUMID-HEAT. INT. CL. 10. REG. 12-12-2000.
 2,411,777. WEE DISCOVER AND DESIGN. INT. CL. 42. REG. 12-12-2000.
 2,411,784. SAXOTECH. INT. CL. 9. REG. 12-12-2000.
 2,411,791. NEWBORN CHANNEL AND DESIGN. INT. CL. 41. REG. 12-12-2000.
 2,411,797. FINANCIAL PEACE OF MIND. INT. CL. 36. REG. 12-12-2000.
 2,411,800. MISCELLANEOUS DESIGN. INT. CL. 9. REG. 12-12-2000.
 2,411,818. TRUSTCORE INSURANCE AGENCY, INC.. INT. CL. 36. REG. 12-12-2000.
 2,411,835. CHESSMATES. INT. CL. 9. REG. 12-12-2000.
 2,411,845. ROMPOWER AND DESIGN. INT. CLS. 9, 40 AND 42. REG. 12-12-2000.
 2,411,849. LEGG. INT. CLS. 7, 9 AND 11. REG. 12-12-2000.
 2,411,856. DRIP LICK. INT. CL. 28. REG. 12-12-2000.
 2,411,859. WOW BASIC KEY SKILLS. INT. CL. 16. REG. 12-12-2000.
 2,411,860. NEEDS FOCUSED LEADERSHIP. INT. CLS. 16 AND 41. REG. 12-12-2000.
 2,411,861. OPTIMIZING FRONT-LINE EMPLOYEE PERFORMANCE. INT. CLS. 16 AND 41. REG. 12-12-2000.
 2,411,862. RESPONSE DESIGN CORPORATION. INT. CLS. 16 AND 41. REG. 12-12-2000.
 2,411,871. LIGHTNIN'. INT. CL. 9. REG. 12-12-2000.
 2,411,881. PUREBEAUTY. INT. CLS. 35 AND 42. REG. 12-12-2000.
 2,411,884. GEOMACK AND DESIGN. INT. CL. 9. REG. 12-12-2000.
 2,411,886. AZIMUTH INTERACTIVE. INT. CL. 9. REG. 12-12-2000.
 2,411,897. ANCIENT PAGE. INT. CL. 16. REG. 12-12-2000.
 2,411,898. WALKING FROG RECORDS AND DESIGN. INT. CL. 35. REG. 12-12-2000.
 2,411,901. IDENTABREW. INT. CL. 20. REG. 12-12-2000.
 2,411,902. WALKING FROG RECORDS. INT. CLS. 9 AND 35. REG. 12-12-2000.
 2,411,903. WALKING FROG RECORDS AND DESIGN. INT. CLS. 9 AND 42. REG. 12-12-2000.
 2,411,904. M CARE AND DESIGN. INT. CLS. 41 AND 42. REG. 12-12-2000.
 2,411,910. MISCELLANEOUS DESIGN. INT. CL. 9. REG. 12-12-2000.
 2,411,911. AVANEX AND DESIGN. INT. CL. 9. REG. 12-12-2000.
 2,411,915. AGELESS CARE. INT. CLS. 35 AND 42. REG. 12-12-2000.
 2,411,939. GARDENSAPES. INT. CL. 42. REG. 12-12-2000.
 2,411,942. BANKRATE.COM AND DESIGN. INT. CL. 36. REG. 12-12-2000.
 2,411,943. THE NATIONAL FEDERATION OF INDIAN-AMERICAN ASSOCIATIONS (STYLIZED). INT. CL. 42. REG. 12-12-2000.
 2,411,947. 774FOOD RESTAURANT CONNECTION. INT. CL. 35. REG. 12-12-2000.
 2,411,952. ROMA BABY AND DESIGN. INT. CLS. 10, 18 AND 25. REG. 12-12-2000.
 2,411,965. VICARAGE. INT. CL. 12. REG. 12-12-2000.
 2,411,969. CUNNINGHAM. INT. CL. 35. REG. 12-12-2000.
 2,411,975. MISCELLANEOUS DESIGN. INT. CL. 41. REG. 12-12-2000.
 2,411,980. INSTEAD O' CHEESE. INT. CL. 29. REG. 12-12-2000.
 2,411,986. THERMOWAYNE. INT. CL. 6. REG. 12-12-2000.
 2,412,000. SEASCAPE PRESS AND DESIGN. INT. CL. 41. REG. 12-12-2000.
 2,412,016. LA LORRAINE AND DESIGN. INT. CL. 30. REG. 12-12-2000.
 2,412,026. WASH 'N GUARD. INT. CL. 21. REG. 12-12-2000.
 2,412,027. A AUTOMATIC SPRING COILING AND DESIGN. INT. CL. 6. REG. 12-12-2000.
 2,412,062. VE (STYLIZED). INT. CL. 42. REG. 12-12-2000.
 2,412,071. CHESSMATES AND DESIGN. INT. CL. 9. REG. 12-12-2000.
 2,412,073. DIGIPLEX. INT. CL. 9. REG. 12-12-2000.
 2,412,077. BROOK MAYS. INT. CLS. 35, 37 AND 41. REG. 12-12-2000.
 2,412,085. FLOW VELOCITY. INT. CL. 42. REG. 12-12-2000.
 2,412,087. SUPPLY VELOCITY. INT. CL. 42. REG. 12-12-2000.
 2,412,090. MISCELLANEOUS DESIGN. INT. CL. 25. REG. 12-12-2000.
 2,412,093. WATERSAFE. INT. CL. 11. REG. 12-12-2000.
 2,412,109. CASTORES. INT. CL. 39. REG. 12-12-2000.
 2,412,118. PLANT REVOLUTION AND DESIGN. INT. CL. 1. REG. 12-12-2000.
 2,412,124. PREVISION. INT. CL. 1. REG. 12-12-2000.
 2,412,130. XC356. INT. CL. 9. REG. 12-12-2000.
 2,412,132. XC355. INT. CL. 9. REG. 12-12-2000.
 2,412,135. VIRTUOZO. INT. CL. 9. REG. 12-12-2000.
 2,412,146. AR ARCHRIVAL AND DESIGN. INT. CL. 42. REG. 12-12-2000.
 2,412,167. REDIPLUS. INT. CL. 9. REG. 12-12-2000.
 2,412,173. DEEPSEA CRUSH. INT. CL. 7. REG. 12-12-2000.
 2,412,178. AMS (STYLIZED). INT. CL. 9. REG. 12-12-2000.
 2,412,179. AMS. INT. CL. 9. REG. 12-12-2000.
 2,412,180. MY PAL. INT. CL. 25. REG. 12-12-2000.
 2,412,205. VERO INTERNATIONAL SOFTWARE. INT. CL. 9. REG. 12-12-2000.
 2,412,208. VISI-SERIES. INT. CL. 9. REG. 12-12-2000.
 2,412,211. VV BY LA BELLA. INT. CL. 5. REG. 12-12-2000.
 2,412,217. ALLERGY LAB SYSTEM. INT. CL. 9. REG. 12-12-2000.
 2,412,219. HWA CHIN AND DESIGN. INT. CL. 42. REG. 12-12-2000.
 2,412,237. INFORMING ARTS. INT. CL. 35. REG. 12-12-2000.
 2,412,239. DMW DEARBORN MID-WEST CONVEYOR CO. AND DESIGN. INT. CLS. 37 AND 42. REG. 12-12-2000.
 2,412,253. MISCELLANEOUS DESIGN. INT. CL. 6. REG. 12-12-2000.
 2,412,260. COPLAVIX (STYLIZED). INT. CL. 5. REG. 12-12-2000.
 2,412,266. LAKE CITY COMMUNITY COLLEGE AND DESIGN. INT. CL. 41. REG. 12-12-2000.
 2,412,270. PERSONAL PLANS AND DESIGN. INT. CL. 36. REG. 12-12-2000.
 2,412,278. RED CARPET. INT. CL. 36. REG. 12-12-2000.
 2,412,279. RED CARPET AND DESIGN. INT. CL. 36. REG. 12-12-2000.
 2,412,284. HERAFREEZE (STYLIZED). INT. CL. 11. REG. 12-12-2000.
 2,412,289. MISCELLANEOUS DESIGN. INT. CLS. 9, 16, 35 AND 41. REG. 12-12-2000.
 2,412,292. COFFEE CAN FUND. INT. CL. 36. REG. 12-12-2000.
 2,412,298. BALE PIK-UP. INT. CL. 7. REG. 12-12-2000.
 2,412,308. MISCELLANEOUS DESIGN. INT. CL. 20. REG. 12-12-2000.
 2,412,309. H AND DESIGN. INT. CL. 20. REG. 12-12-2000.
 2,412,310. MISCELLANEOUS DESIGN. INT. CL. 20. REG. 12-12-2000.
 2,412,321. GREATWINDOWS.COM. INT. CL. 35. REG. 12-12-2000.
 2,412,326. 53787. INT. CLS. 14 AND 25. REG. 12-12-2000.
 2,412,327. CHILD FOCUS, INC. WE CARE FOR CHILDREN AND DESIGN. INT. CL. 42. REG. 12-12-2000.

- 2,412,356. PHOTOWALL. INT. CL. 42. REG. 12-12-2000.
 2,412,360. CHARLOTTE & FRIENDS (STYLIZED). INT. CL. 25. REG. 12-12-2000.
 2,412,362. CHARLOTTE & FRIENDS (STYLIZED). INT. CL. 3. REG. 12-12-2000.
 2,412,365. THE FITNESS CHURCH. INT. CL. 41. REG. 12-12-2000.
 2,412,375. TOOLSHED UNDERGARB AND DESIGN. INT. CL. 25. REG. 12-12-2000.
 2,412,376. OSKAR EMIL. INT. CL. 14. REG. 12-12-2000.
 2,412,377. ADVENTURES. INT. CL. 16. REG. 12-12-2000.
 2,412,379. MLM AND DESIGN. INT. CLS. 9 AND 16. REG. 12-12-2000.
 2,412,389. WFI AND DESIGN. INT. CL. 37. REG. 12-12-2000.
 2,412,390. WFI AND DESIGN. INT. CL. 42. REG. 12-12-2000.
 2,412,397. ROYAL EDITION. INT. CL. 11. REG. 12-12-2000.
 2,412,403. TAT WONG KUNG FU ACADEMY AND DESIGN. INT. CL. 41. REG. 12-12-2000.
 2,412,406. OMNI ALOE. INT. CL. 5. REG. 12-12-2000.
 2,412,407. MISCELLANEOUS DESIGN. INT. CLS. 35 AND 37. REG. 12-12-2000.
 2,412,417. PICK A BAGEL. INT. CL. 35. REG. 12-12-2000.
 2,412,418. AUTOMALL OF AMERICA AND DESIGN. INT. CL. 35. REG. 12-12-2000.
 2,412,421. NEWPORT INTERNATIONAL FILM FESTIVAL AND DESIGN. INT. CL. 41. REG. 12-12-2000.
 2,412,430. HOT POLISH. INT. CL. 37. REG. 12-12-2000.
 2,412,433. MISCELLANEOUS DESIGN. INT. CLS. 36 AND 37. REG. 12-12-2000.
 2,412,443. TITANIUM AND DESIGN. INT. CL. 8. REG. 12-12-2000.
 2,412,455. SPECTRAVIDEO. INT. CL. 9. REG. 12-12-2000.
 2,412,464. ELECTRICAL TRAINING CENTER INC, FOR A BRIGHTER FUTURE AND DESIGN. INT. CL. 41. REG. 12-12-2000.
 2,412,468. JERICHO. INT. CL. 36. REG. 12-12-2000.
 2,412,491. SURADO SMART HOME MANAGER. INT. CL. 9. REG. 12-12-2000.
 2,412,503. YOU'LL BE MOVED BY OUR EXPERTISE. INT. CL. 35. REG. 12-12-2000.
 2,412,523. SOLUTIONEERING. INT. CL. 42. REG. 12-12-2000.
 2,412,524. PETRO ZILLIA. INT. CLS. 18 AND 25. REG. 12-12-2000.
 2,412,532. MISCELLANEOUS DESIGN. INT. CL. 42. REG. 12-12-2000.
 2,412,533. DEEP RIVER PARTNERS. INT. CL. 42. REG. 12-12-2000.
 2,412,551. SWEETS BY SWEETS. INT. CL. 30. REG. 12-12-2000.
 2,412,553. GREENEWABLE. INT. CL. 35. REG. 12-12-2000.
 2,412,561. "PROMOTING QUALITY. PRESERVING CHOICE" (STYLIZED). INT. CL. 36. REG. 12-12-2000.
 2,412,566. S.G.G. AND DESIGN. INT. CL. 42. REG. 12-12-2000.
 2,412,574. SHOCKER SPORT. INT. CL. 28. REG. 12-12-2000.
 2,412,580. I OPENER. INT. CL. 21. REG. 12-12-2000.
 2,412,593. RAINBOW BRIDGE. INT. CL. 42. REG. 12-12-2000.
 2,412,596. VFINANCE.COM. INT. CL. 36. REG. 12-12-2000.
 2,412,601. GOELST AND DESIGN. INT. CL. 20. REG. 12-12-2000.
 2,412,602. NVEC. INT. CL. 9. REG. 12-12-2000.
 2,412,627. IN HARMONY WITH EDUCATION. INT. CL. 41. REG. 12-12-2000.
 2,412,645. THE POWER OF FRESH FLOWERS. INT. CL. 35. REG. 12-12-2000.
 2,412,646. JRI RECORDINGS AND DESIGN. INT. CL. 9. REG. 12-12-2000.
 2,412,662. RIGHT-FROM-HOME. INT. CL. 35. REG. 12-12-2000.
 2,412,664. BECAUSE ITALY IS TOO FAR TO DRIVE. INT. CL. 42. REG. 12-12-2000.
 2,412,668. CAPTURE CARD. INT. CL. 16. REG. 12-12-2000.
 2,412,674. PRESS RECORDS. INT. CL. 9. REG. 12-12-2000.
 2,412,684. WHERE FISH IS OUR MIDDLE NAME. INT. CL. 42. REG. 12-12-2000.
 2,412,693. AGAIN. INT. CL. 16. REG. 12-12-2000.
 2,412,697. CELLULARONE (STYLIZED). INT. CL. 27. REG. 12-12-2000.
 2,412,698. CELLULARONE (STYLIZED). INT. CL. 11. REG. 12-12-2000.
 2,412,699. CELLULARONE (STYLIZED). INT. CL. 6. REG. 12-12-2000.
 2,412,717. PERRY ELLIS AMERICA AND DESIGN. INT. CL. 3. REG. 12-12-2000.
 2,412,721. PRO-FIT. INT. CL. 40. REG. 12-12-2000.
 2,412,754. ZERMAT ELEGANZZA. INT. CL. 3. REG. 12-12-2000.
 2,412,758. KAMA SUTRA. INT. CL. 10. REG. 12-12-2000.
 2,412,762. BONE APPETIT (STYLIZED). INT. CLS. 35 AND 39. REG. 12-12-2000.
 2,412,765. POCKETECH. INT. CL. 8. REG. 12-12-2000.
 2,412,775. KING KONG. INT. CL. 28. REG. 12-12-2000.
 2,412,776. BEAK. INT. CL. 10. REG. 12-12-2000.
 2,412,790. P B & J OTTER. INT. CL. 41. REG. 12-12-2000.
 2,412,791. DC DERMOCOSMETICA (STYLIZED). INT. CL. 3. REG. 12-12-2000.
 2,412,794. PUSHOVER. INT. CL. 20. REG. 12-12-2000.
 2,412,799. PRIZEENVELOPE. INT. CL. 36. REG. 12-12-2000.
 2,412,801. ATLANTIC EPIC. INT. CL. 18. REG. 12-12-2000.
 2,412,805. ROBOPRO. INT. CL. 8. REG. 12-12-2000.
 2,412,814. DOMINIC BELLISSIMO DB AND DESIGN. INT. CLS. 9 AND 25. REG. 12-12-2000.
 2,412,827. 3D GAMEGAUGE. INT. CL. 9. REG. 12-12-2000.
 2,412,830. TOMICA WORLD. INT. CL. 28. REG. 12-12-2000.
 2,412,837. HEMAVISION. INT. CL. 10. REG. 12-12-2000.
 2,412,838. FRISBEE DOG. INT. CL. 28. REG. 12-12-2000.
 2,412,839. SPHERE. INT. CL. 18. REG. 12-12-2000.
 2,412,841. MISCELLANEOUS DESIGN. INT. CL. 16. REG. 12-12-2000.
 2,412,853. BODYLASTICS AND DESIGN. INT. CL. 28. REG. 12-12-2000.
 2,412,858. AMPLITUDE. INT. CL. 3. REG. 12-12-2000.
 2,412,860. WINSHIP PROPERTIES AND DESIGN. INT. CL. 36. REG. 12-12-2000.
 2,412,866. CRESTHILL SUITES. INT. CL. 42. REG. 12-12-2000.
 2,412,869. LITTLE SCIENTISTS. INT. CL. 9. REG. 12-12-2000.
 2,412,881. HYDRAMYTHIC AND DESIGN. INT. CL. 3. REG. 12-12-2000.
 2,412,888. TXU. INT. CL. 42. REG. 12-12-2000.
 2,412,889. CROSSROADS CUISINES CAFE AND DESIGN. INT. CL. 42. REG. 12-12-2000.
 2,412,890. H SINCE 1898 AND DESIGN. INT. CL. 16. REG. 12-12-2000.
 2,412,891. MISCELLANEOUS DESIGN. INT. CL. 25. REG. 12-12-2000.
 2,412,892. BRASS-LOC. INT. CL. 1. REG. 12-12-2000.
 2,412,900. CSG STATEMENT EXPRESS. INT. CL. 9. REG. 12-12-2000.
 2,412,906. BADGER 5 PLUS. INT. CL. 7. REG. 12-12-2000.
 2,412,915. FLEUR DE LIS. INT. CL. 20. REG. 12-12-2000.
 2,412,918. MUSIC N' MOTION. INT. CL. 28. REG. 12-12-2000.
 2,412,922. EVERYLASH. INT. CL. 3. REG. 12-12-2000.
 2,412,942. MICROLOCK. INT. CL. 24. REG. 12-12-2000.
 2,412,943. M AND DESIGN. INT. CL. 6. REG. 12-12-2000.
 2,412,949. IT'S ALL ABOUT THE BEER. INT. CL. 32. REG. 12-12-2000.
 2,412,953. CHINA SEA. INT. CLS. 29 AND 30. REG. 12-12-2000.
 2,412,956. JUST 4 JESUS (STYLIZED). INT. CL. 25. REG. 12-12-2000.
 2,412,960. RELY AID AND DESIGN. INT. CL. 21. REG. 12-12-2000.
 2,412,962. PHARMATE DISPENSER. INT. CL. 11. REG. 12-12-2000.
 2,412,963. WHIPPERSNAPPER. INT. CL. 7. REG. 12-12-2000.
 2,412,966. LOGIC. INT. CL. 19. REG. 12-12-2000.
 2,412,967. APEGO. INT. CL. 16. REG. 12-12-2000.
 2,412,972. AUTOIRA. INT. CL. 9. REG. 12-12-2000.
 2,412,985. ST. ELMO RESTAURANT. INT. CL. 42. REG. 12-12-2000.
 2,412,988. ST. ELMO GRILL. INT. CL. 42. REG. 12-12-2000.
 2,412,992. ENLIVEN. INT. CL. 42. REG. 12-12-2000.
 2,412,998. MIRR.EDGE. INT. CL. 20. REG. 12-12-2000.

- 2,412,999. THE MUTINY (STYLIZED). INT. CL. 42. REG. 12-12-2000.
- 2,413,000. FUZZY FEET. INT. CL. 25. REG. 12-12-2000.
- 2,413,008. SAN MARINO. INT. CL. 11. REG. 12-12-2000.
- 2,413,009. ST. LAWRENCE. INT. CL. 11. REG. 12-12-2000.
- 2,413,028. ST. ELMO CHOP HOUSE. INT. CL. 42. REG. 12-12-2000.
- 2,413,029. PRESTONE. INT. CL. 1. REG. 12-12-2000.
- 2,413,046. ALLERGYTALK (STYLIZED). INT. CLS. 16 AND 42. REG. 12-12-2000.
- 2,413,052. GOING YARD. INT. CL. 16. REG. 12-12-2000.
- 2,413,079. THERMOLITE. INT. CL. 5. REG. 12-12-2000.
- 2,413,084. LITTER SECRET. INT. CL. 31. REG. 12-12-2000.
- 2,413,086. SEAM STITCH. INT. CL. 19. REG. 12-12-2000.
- 2,413,089. INNO-THERM. INT. CL. 17. REG. 12-12-2000.
- 2,413,100. NASR. INT. CL. 42. REG. 12-12-2000.
- 2,413,116. HR175. INT. CL. 19. REG. 12-12-2000.
- 2,413,125. SKIN I.Q.. INT. CL. 3. REG. 12-12-2000.
- 2,413,145. FRED'S OLDE MILL STEAKHOUSE. INT. CL. 42. REG. 12-12-2000.
- 2,413,152. ADAPTATION-PSYCHOLOGY FOR A CHANGING WORLD. INT. CL. 42. REG. 12-12-2000.
- 2,413,154. BLACK HOLE. INT. CL. 28. REG. 12-12-2000.
- 2,413,166. SWITCH CRAFT. INT. CL. 3. REG. 12-12-2000.
- 2,413,169. BUSY PEOPLE'S LOW-FAT. INT. CL. 16. REG. 12-12-2000.
- 2,413,177. BLAINE. INT. CL. 28. REG. 12-12-2000.
- 2,413,181. OFFSETMASTER. INT. CL. 11. REG. 12-12-2000.
- 2,413,197. NINA FMM BARNES EAST HAMPTON, NY AND DESIGN. INT. CL. 3. REG. 12-12-2000.
- 2,413,220. WARP HYPER CHARGED AND DESIGN. INT. CL. 30. REG. 12-12-2000.
- 2,413,221. WARP (STYLIZED). INT. CL. 30. REG. 12-12-2000.
- 2,413,225. HEALTHY WEALTHY WISE. INT. CL. 3. REG. 12-12-2000.
- 2,413,229. ED.NET. INT. CL. 42. REG. 12-12-2000.
- 2,413,234. VITACYTE. INT. CL. 3. REG. 12-12-2000.
- 2,413,257. 1-800-ONE-LOAN. INT. CL. 36. REG. 12-12-2000.
- 2,413,259. DISKMAPPER. INT. CL. 9. REG. 12-12-2000.
- 2,413,262. THE ROUTER WORKSHOP. INT. CL. 41. REG. 12-12-2000.
- 2,413,267. PATIO GOURMET. INT. CL. 11. REG. 12-12-2000.
- 2,413,268. CUSTOMER ACQUISITION MATRIX. INT. CL. 35. REG. 12-12-2000.
- 2,413,272. TOKYOPOP. INT. CL. 16. REG. 12-12-2000.
- 2,413,282. FORMAT PRO. INT. CL. 9. REG. 12-12-2000.
- 2,413,284. CLASS A INSTANT FIRE BEHAVIOR FLASH-OVERS & BACKDRAFTS. INT. CL. 16. REG. 12-12-2000.
- 2,413,292. FRAUD PREVENTION TEAM. INT. CL. 16. REG. 12-12-2000.
- 2,413,297. ASSET MANAGER: AGGRESSIVE. INT. CL. 36. REG. 12-12-2000.
- 2,413,306. COMMUNITY SLEEP AWARENESS PARTNER. INT. CL. 42. REG. 12-12-2000.
- 2,431,885. REACTOR. INT. CLS. 9 AND 28. REG. 2-27-2001.
- 2,434,782. MISCELLANEOUS DESIGN. INT. CL. 35 ONLY. REG. 3-13-2001.
- 2,447,329. AMARETTA. INT. CL. 25 ONLY. REG. 5-1-2001.
- 2,450,187. SKIDMARKS. INT. CL. 12. REG. 5-8-2001.
- 2,456,790. NETLADDER.COM. INT. CL. 42. REG. 6-5-2001.
- 2,461,042. VTOWN AND DESIGN. INT. CL. 42. REG. 6-19-2001.
- 2,466,318. ZIP-TOGGLE. INT. CL. 20 ONLY. REG. 7-3-2001.
- 2,470,890. MISCELLANEOUS DESIGN. INT. CL. 25 ONLY. REG. 7-24-2001.
- 2,474,863. MISCELLANEOUS DESIGN. INT. CL. 25 ONLY. REG. 8-7-2001.
- 2,476,229. ... AND WE DELIVER. INT. CL. 39 ONLY. REG. 8-7-2001.
- 2,480,919. TRADESPHERE. INT. CL. 35 ONLY. REG. 8-21-2001.
- 2,481,167. CUNINGHAM GROUP. INT. CL. 37 ONLY. REG. 8-28-2001.
- 2,495,599. POCAHONTAS. INT. CL. 35 ONLY. REG. 10-9-2001.
- 2,513,241. PUTNAM TAX SMART EQUITY FUND. INT. CL. 36. REG. 11-27-2001.
- 2,525,808. WEATHERBEATER. INT. CL. 12. REG. 1-1-2002.
- 2,575,860. CARTVU. INT. CL. 9. REG. 6-4-2002.
- 2,590,063. HR ASSESSMENTS. INT. CL. 9 ONLY. REG. 7-2-2002.
- 2,604,385. SONOREAL. INT. CL. 10. REG. 8-6-2002.
- 2,620,803. KH (STYLIZED). INT. CL. 40. REG. 9-17-2002.
- 2,629,284. BUYUSA.COM. INT. CL. 35. REG. 10-1-2002.
- 2,697,527. HEUERMANN'S MAGIC MUSHROOM POP-CORN AND DESIGN. INT. CL. 31. REG. 3-18-2003.
- 2,702,677. SELL YOUR HOME IN A WEEK. INT. CL. 36. REG. 4-1-2003.
- 2,713,139. IWI MOTOR PARTS AND DESIGN. INT. CL. 7. REG. 5-6-2003.
- 2,721,758. WHERE WE WEB. INT. CL. 41. REG. 6-3-2003.
- 2,740,441. XPERTUS. INT. CL. 9. REG. 7-22-2003.
- 2,758,282. MOSIX. INT. CL. 9. REG. 9-2-2003.
- 2,759,681. FANA. INT. CL. 14. REG. 9-2-2003.
- 2,783,997. ACCESS BANKCARD AND DESIGN. INT. CL. 36. REG. 11-18-2003.
- 2,799,767. BUILT FOR THE MISSION. INT. CL. 12. REG. 12-30-2003.
- 2,823,247. SKILLS MASTERY AND RESISTANCE TRAINING. INT. CL. 41. REG. 3-16-2004.
- 2,875,622. FINANCIAL CONVERSATIONS. INT. CL. 41. REG. 8-17-2004.
- 2,905,364. SCRATCH. INT. CL. 41. REG. 11-23-2004.
- 2,905,413. BRUNO BANANI. INT. CLS. 16, 20 AND 28 ONLY. REG. 11-30-2004.
- 2,908,306. HORSE LOVERS ARE STABLE PEOPLE. INT. CL. 16. REG. 12-7-2004.
- 2,909,347. U.S. ELECTRONICS. INT. CL. 9. REG. 12-14-2004.
- 2,909,349. TOP-GEL. INT. CL. 3. REG. 12-14-2004.
- 2,909,350. DESIGN. INT. CLS. 14 AND 21. REG. 12-14-2004.
- 2,909,351. TANGENT MOBILE OFFICE AND DESIGN. INT. CL. 9. REG. 12-14-2004.
- 2,909,353. SPORT ICE AND DESIGN. INT. CLS. 18 AND 25. REG. 12-14-2004.
- 2,909,354. RELUCID. INT. CL. 5. REG. 12-14-2004.
- 2,909,355. FUSCO AND DESIGN. INT. CLS. 9, 14, 18 AND 25. REG. 12-14-2004.
- 2,909,357. COMEX AND DESIGN. INT. CL. 27. REG. 12-14-2004.
- 2,909,359. LIQUISACK. INT. CLS. 20 AND 22. REG. 12-14-2004.
- 2,909,360. LIQUISACK AND DESIGN. INT. CLS. 20 AND 22. REG. 12-14-2004.
- 2,909,366. NADEX. INT. CL. 25. REG. 12-14-2004.
- 2,909,368. QUICK LISTS. INT. CL. 35. REG. 12-14-2004.
- 2,909,370. EASTER ISLAND. INT. CL. 32. REG. 12-14-2004.
- 2,909,371. ROM. INT. CL. 19. REG. 12-14-2004.
- 2,909,373. THE BUZZ (STYLIZED). INT. CL. 35. REG. 12-14-2004.
- 2,909,376. QUEST AUSTRALIA. INT. CLS. 39 AND 42. REG. 12-14-2004.
- 2,909,377. GLOBAL QUEST. INT. CL. 39. REG. 12-14-2004.
- 2,909,378. MARGADAN. INT. CL. 29. REG. 12-14-2004.
- 2,909,379. TRANSCANADA AND DESIGN. INT. CLS. 35 AND 39. REG. 12-14-2004.
- 2,909,380. KINGNET. INT. CL. 9. REG. 12-14-2004.
- 2,909,381. DOCUMANAGE. INT. CLS. 9 AND 42. REG. 12-14-2004.
- 2,909,382. WEXCOAT. INT. CL. 1. REG. 12-14-2004.
- 2,909,383. HUMAN SPIRIT. INT. CLS. 9, 16, 18, 25, 28, 35, 38 AND 41. REG. 12-14-2004.
- 2,909,384. ANGELMOUSE. INT. CLS. 9, 16, 25, 28 AND 41. REG. 12-14-2004.
- 2,909,387. CABLEL. INT. CL. 9. REG. 12-14-2004.
- 2,909,388. RESPONSIBLE COMMUNICATIONS. INT. CL. 41. REG. 12-14-2004.
- 2,909,390. CAFE CUSTEPEC AND DESIGN. INT. CL. 30. REG. 12-14-2004.
- 2,909,391. INTERNET LIFE. INT. CL. 42. REG. 12-14-2004.
- 2,909,394. ZYRKAMINE. INT. CL. 5. REG. 12-14-2004.
- 2,909,396. CORPORATE CLEAR ADVANTAGE PROGRAM. INT. CL. 42. REG. 12-14-2004.
- 2,909,397. RONA INDUSTRIUM AND DESIGN. INT. CLS. 3 AND 35. REG. 12-14-2004.

- 2,909,400. AQUILA INSIDER. INT. CL. 40. REG. 12-14-2004.
 2,909,401. L'IL SCOOPS. INT. CL. 30. REG. 12-14-2004.
 2,909,402. WANGO. INT. CLS. 9 AND 41. REG. 12-14-2004.
 2,909,403. PET FILES TV. INT. CL. 41. REG. 12-14-2004.
 2,909,409. GELBE AKTIE. INT. CLS. 16, 35 AND 36. REG. 12-14-2004.
 2,909,410. AUSVEGAS. INT. CL. 38. REG. 12-14-2004.
 2,909,411. AUSVEGAS. INT. CL. 35. REG. 12-14-2004.
 2,909,414. USSHER'S CREEK AND DESIGN. INT. CLS. 25 AND 41. REG. 12-14-2004.
 2,909,417. FUN ZONE. INT. CL. 38. REG. 12-14-2004.
 2,909,418. WORLDWIDE RENAISSANCE. INT. CL. 42. REG. 12-14-2004.
 2,909,419. WASAH AND DESIGN. INT. CLS. 9, 16 AND 41. REG. 12-14-2004.
 2,909,420. TURBANALAND (STYLIZED). INT. CL. 35. REG. 12-14-2004.
 2,909,421. TURBANALAND. INT. CL. 38. REG. 12-14-2004.
 2,909,424. AQUALIFE. INT. CLS. 11 AND 32. REG. 12-14-2004.
 2,909,427. CREDIT READY. INT. CL. 36. REG. 12-14-2004.
 2,909,428. SHOOFLY SHOES. INT. CL. 25. REG. 12-14-2004.
 2,909,429. STINGER. INT. CL. 28. REG. 12-14-2004.
 2,909,430. PEAK BAR. INT. CL. 30. REG. 12-14-2004.
 2,909,431. RAMANDOLO AND DESIGN. INT. CL. 33. REG. 12-14-2004.
 2,909,432. OUR AMBITION IS TO CREATE THE DIFFERENCE THROUGH INSPIRATIONAL SENSORY DESIGN. INT. CLS. 1, 3, 5, 29, 30 AND 32. REG. 12-14-2004.
 2,909,436. FOURSTICKS AND DESIGN. INT. CLS. 9, 38 AND 42. REG. 12-14-2004.
 2,909,439. SOCKEYE SOLUTIONS. INT. CL. 9. REG. 12-14-2004.
 2,909,440. PROTEOACTIVE. INT. CL. 42. REG. 12-14-2004.
 2,909,443. HAPPY ROCKS. INT. CL. 21. REG. 12-14-2004.
 2,909,444. FRESHIDEAS (STYLIZED). INT. CLS. 9 AND 16. REG. 12-14-2004.
 2,909,445. L.R. GUY (STYLIZED). INT. CL. 25. REG. 12-14-2004.
 2,909,451. SANCHEZ. INT. CLS. 9, 35, 36 AND 42. REG. 12-14-2004.
 2,909,452. CENTERPRISE. INT. CL. 36. REG. 12-14-2004.
 2,909,453. UPM3 (STYLIZED). INT. CL. 5. REG. 12-14-2004.
 2,909,455. IMPERIAL CHEMICAL INDUSTRIES. INT. CLS. 1, 2, 3, 4, 5, 7, 9, 11, 16, 17, 19, 29, 30, 35, 36, 37, 39, 40, 41 AND 42. REG. 12-14-2004.
 2,909,456. FIBERSOLUTIONS (STYLIZED). INT. CLS. 16, 17, 21, 23 AND 24. REG. 12-14-2004.
 2,909,457. CARECARD. INT. CL. 35. REG. 12-14-2004.
 2,909,458. UNITRON HEARING AND DESIGN. INT. CL. 10. REG. 12-14-2004.
 2,909,459. MACT. INT. CLS. 5 AND 42. REG. 12-14-2004.
 2,909,462. MISCELLANEOUS DESIGN. INT. CLS. 36 AND 41. REG. 12-14-2004.
 2,909,463. DCL BLUESKY (STYLIZED). INT. CL. 7. REG. 12-14-2004.
 2,909,467. CRIME CONTROL CENTRE.COM. INT. CL. 35. REG. 12-14-2004.
 2,909,469. PROTEMIX. INT. CLS. 5, 42 AND 44. REG. 12-14-2004.
 2,909,470. VANS-TO-GO. INT. CL. 39. REG. 12-14-2004.
 2,909,471. MIRACLES 4 FUN. INT. CL. 28. REG. 12-14-2004.
 2,909,472. LT-CI. INT. CLS. 7 AND 9. REG. 12-14-2004.
 2,909,476. B2V. INT. CLS. 3 AND 44. REG. 12-14-2004.
 2,909,477. ANACARDIUM AND DESIGN. INT. CLS. 5, 29, 30, 31, 41, 42 AND 44. REG. 12-14-2004.
 2,909,483. LEX LOOPS. INT. CL. 28. REG. 12-14-2004.
 2,909,485. PC ON CALL MAKING COMPUTER TECHNOLOGY WORK FOR BUSINESS. GUARANTEED. AND DESIGN. INT. CLS. 37 AND 42. REG. 12-14-2004.
 2,909,488. MISCELLANEOUS DESIGN. INT. CLS. 1, 30 AND 42. REG. 12-14-2004.
 2,909,489. KONA CAUCA ORGANIC CAFE AND DESIGN. INT. CL. 30. REG. 12-14-2004.
 2,909,490. HEAVY HITTAS. INT. CLS. 9, 35 AND 41. REG. 12-14-2004.
 2,909,492. YUKON. INT. CL. 10. REG. 12-14-2004.
 2,909,493. WYNNE. INT. CLS. 35 AND 43. REG. 12-14-2004.
 2,909,495. WYNNE RESIDENTIAL CORPORATE HOUSING. INT. CLS. 35 AND 43. REG. 12-14-2004.
 2,909,496. MONTE LINDO. INT. CL. 33. REG. 12-14-2004.
 2,909,498. LIVLON. INT. CLS. 29, 30, 31 AND 32. REG. 12-14-2004.
 2,909,499. SEEKDATA. INT. CLS. 9 AND 16. REG. 12-14-2004.
 2,909,501. D-LOC. INT. CL. 6. REG. 12-14-2004.
 2,909,502. CRUZAN CITRUS RUM PREMIUM CRUZAN RUM WITH NATURAL CITRUS FLAVORS JUNKANU! AND DESIGN. INT. CL. 33. REG. 12-14-2004.
 2,909,506. INTERNET AT THE SPEED OF YOU. INT. CLS. 38 AND 42. REG. 12-14-2004.
 2,909,508. ROCKETDELIVERY. INT. CL. 9. REG. 12-14-2004.
 2,909,510. AUSPIRIT. INT. CL. 39. REG. 12-14-2004.
 2,909,511. NIX 99. INT. CLS. 7, 9, 11 AND 12. REG. 12-14-2004.
 2,909,518. ETSX. INT. CL. 12. REG. 12-14-2004.
 2,909,523. AIR ANGELS AND DESIGN. INT. CL. 39. REG. 12-14-2004.
 2,909,524. PREMIER WEALTH PLAN. INT. CL. 36. REG. 12-14-2004.
 2,909,525. PUTTING THE POWER OF .NET TO WORK. INT. CL. 42. REG. 12-14-2004.
 2,909,534. PICTURE THEM SAFE. INT. CLS. 16 AND 45. REG. 12-14-2004.
 2,909,535. MISCELLANEOUS DESIGN. INT. CL. 43. REG. 12-14-2004.
 2,909,536. NCC. INT. CL. 9. REG. 12-14-2004.
 2,909,537. MONKEY MUFFINS. INT. CL. 30. REG. 12-14-2004.
 2,909,538. HR SMART START AND DESIGN. INT. CL. 9. REG. 12-14-2004.
 2,909,540. BIG COUNT 51 AND DESIGN. INT. CL. 8. REG. 12-14-2004.
 2,909,541. BIG COUNT 50 AND DESIGN. INT. CL. 8. REG. 12-14-2004.
 2,909,543. SIZZLIN' SAUTÉ BACON CHEESEBURGER (STYLIZED). INT. CL. 30. REG. 12-14-2004.
 2,909,545. ALMIGHTY. INT. CL. 9. REG. 12-14-2004.
 2,909,550. RXACCESS AND DESIGN. INT. CLS. 36 AND 44. REG. 12-14-2004.
 2,909,553. BAZZACAP. INT. CL. 25. REG. 12-14-2004.
 2,909,555. NETDISCOVERY. INT. CLS. 38, 39 AND 42. REG. 12-14-2004.
 2,909,556. TIGERADE. INT. CL. 32. REG. 12-14-2004.
 2,909,559. COUNT ON CONCRETE. INT. CL. 16. REG. 12-14-2004.
 2,909,560. HONGSAMNARA AND DESIGN. INT. CL. 30. REG. 12-14-2004.
 2,909,561. 2/ONE OVERLAP. INT. CL. 9. REG. 12-14-2004.
 2,909,566. EASYCRUISE. INT. CLS. 16, 39, 42 AND 43. REG. 12-14-2004.
 2,909,569. BIO COMPLEX STANDARD CHARACTER MARK. INT. CL. 3. REG. 12-14-2004.
 2,909,573. ION. INT. CL. 20. REG. 12-14-2004.
 2,909,574. ION POWER BASE SERIES. INT. CL. 20. REG. 12-14-2004.
 2,909,577. U.S. GENOMICS AND DESIGN. INT. CL. 9. REG. 12-14-2004.
 2,909,579. ERNEST'S CAFE KEY WEST AND DESIGN. INT. CLS. 35 AND 43. REG. 12-14-2004.
 2,909,580. O AND DESIGN. INT. CL. 9. REG. 12-14-2004.
 2,909,583. THE GREAT HOTELS OF THE WORLD AND DESIGN. INT. CL. 35. REG. 12-14-2004.
 2,909,584. IT TELEVISION. INT. CL. 41. REG. 12-14-2004.
 2,909,587. EASTERNS OF WOODBRIDGE. INT. CL. 35. REG. 12-14-2004.
 2,909,588. EASTERNS AUTO MAXX. INT. CL. 35. REG. 12-14-2004.
 2,909,590. COUNTONUS! WHERE EVERY HOUR COUNTS AND DESIGN. INT. CL. 42. REG. 12-14-2004.
 2,909,595. SMARTWIREX. INT. CLS. 9, 16 AND 42. REG. 12-14-2004.

- 2,909,596. NEW YORKERS SINCE 1784. INT. CL. 36. REG. 12-14-2004.
- 2,909,599. SMEV. INT. CLS. 11 AND 21. REG. 12-14-2004.
- 2,909,601. IFS AND DESIGN. INT. CL. 42. REG. 12-14-2004.
- 2,909,605. CHUBBY BAITs AND DESIGN. INT. CL. 25. REG. 12-14-2004.
- 2,909,606. JEI JOHNSON ELECTRIC AND DESIGN. INT. CLS. 35, 40 AND 42 ONLY. REG. 12-14-2004.
- 2,909,607. P&W SOLUTIONS. INT. CL. 35. REG. 12-14-2004.
- 2,909,611. QUICKSYSTEMS. INT. CL. 9. REG. 12-14-2004.
- 2,909,612. AQUAVERTER. INT. CL. 11. REG. 12-14-2004.
- 2,909,617. AEROCKED AND DESIGN. INT. CL. 42. REG. 12-14-2004.
- 2,909,618. OCEG. INT. CLS. 41 AND 42. REG. 12-14-2004.
- 2,909,620. PDX - IVIVC. INT. CLS. 9 AND 42. REG. 12-14-2004.
- 2,909,621. AMDIPHARM. INT. CLS. 5 AND 10. REG. 12-14-2004.
- 2,909,622. LASCBOARD. INT. CL. 19. REG. 12-14-2004.
- 2,909,628. IN-SITU CORONA. INT. CL. 40. REG. 12-14-2004.
- 2,909,634. 530. INT. CL. 12. REG. 12-14-2004.
- 2,909,636. GOLD SPUR. INT. CL. 28. REG. 12-14-2004.
- 2,909,637. THE GADGET GURU AND DESIGN. INT. CL. 35. REG. 12-14-2004.
- 2,909,642. WORKING DINNERS.COM. INT. CL. 35. REG. 12-14-2004.
- 2,909,643. SAVANT. INT. CL. 23. REG. 12-14-2004.
- 2,909,645. MISCELLANEOUS DESIGN. INT. CLS. 28 AND 35. REG. 12-14-2004.
- 2,909,653. SYNNET. INT. CL. 42. REG. 12-14-2004.
- 2,909,660. VOIVOD. INT. CL. 9. REG. 12-14-2004.
- 2,909,662. AMERICARE AND DESIGN. INT. CLS. 9, 16, 18, 21, 35, 36 AND 41. REG. 12-14-2004.
- 2,909,666. WILMAN. INT. CL. 27. REG. 12-14-2004.
- 2,909,669. EAU GENEUSE. INT. CL. 3. REG. 12-14-2004.
- 2,909,670. US ANGLERS ASSOCIATION AND DESIGN. INT. CL U.S. CLS. 200, 200 AND 200. REG. 12-14-2004.
- 2,909,671. HOUSE TRADER. INT. CLS. 16 AND 35. REG. 12-14-2004.
- 2,909,672. TRIODOS. INT. CL. 36. REG. 12-14-2004.
- 2,909,673. PLUMBERS ACCESS. INT. CLS. 2, 6, 8, 9, 11, 17 AND 21. REG. 12-14-2004.
- 2,909,674. ECKERXD RX CONNECTIONS INFORMATION FOR HEALTHY LIVING. INT. CL. 35. REG. 12-14-2004.
- 2,909,675. TURBOTACK TECHNOLOGY. INT. CL. 1. REG. 12-14-2004.
- 2,909,676. STRONG ARM. INT. CL. 35. REG. 12-14-2004.
- 2,909,678. HIRECREDITPRO. INT. CL. 9. REG. 12-14-2004.
- 2,909,682. TANKTRONIC. INT. CLS. 7, 9, 12 AND 17. REG. 12-14-2004.
- 2,909,686. MORTGAGE LINQ AND DESIGN. INT. CL. 42. REG. 12-14-2004.
- 2,909,691. TKY KAI YIH AND DESIGN. INT. CL. 12. REG. 12-14-2004.
- 2,909,701. HUGHES AIRPORT CENTER. INT. CL. 36. REG. 12-14-2004.
- 2,909,702. TEAM SUPREME AND DESIGN. INT. CLS. 16, 28 AND 41. REG. 12-14-2004.
- 2,909,703. TEAM SUPREME. INT. CL. 28. REG. 12-14-2004.
- 2,909,704. BEDTIME PALS. INT. CL. 28. REG. 12-14-2004.
- 2,909,705. PRECIOUS POCKETS. INT. CL. 28. REG. 12-14-2004.
- 2,909,707. BODYPRAYERPATH. INT. CL. 41. REG. 12-14-2004.
- 2,909,710. I2. INT. CL. 9. REG. 12-14-2004.
- 2,909,712. WINGS OF WONDER WHEN LEARNING TAKES FLIGHT.... INT. CLS. 35 AND 41. REG. 12-14-2004.
- 2,909,714. SHADOW PYRAMID. INT. CL. 35. REG. 12-14-2004.
- 2,909,715. TRIHEXENOL STANDARD CHARACTER MARK. INT. CL. 1. REG. 12-14-2004.
- 2,909,716. HD LASIK. INT. CL. 44. REG. 12-14-2004.
- 2,909,719. DIESEL DYNAMICS. INT. CLS. 7 AND 37. REG. 12-14-2004.
- 2,909,720. STUDIO B UNCOMMONLY ELEGANT. UNQUESTIONABLY BRUCE. AND DESIGN. INT. CL. 19. REG. 12-14-2004.
- 2,909,722. MISCELLANEOUS DESIGN. INT. CL. 41. REG. 12-14-2004.
- 2,909,724. SANIBEL SANDALS. INT. CL. 14. REG. 12-14-2004.
- 2,909,725. STAUB. INT. CL. 21. REG. 12-14-2004.
- 2,909,726. MISCELLANEOUS DESIGN. INT. CL. 21. REG. 12-14-2004.
- 2,909,729. KG (STYLIZED). INT. CL. 35. REG. 12-14-2004.
- 2,909,730. VIVID GIRL. INT. CL. 41. REG. 12-14-2004.
- 2,909,732. METAMORPHOSIS OF RAW MATERIALS. INT. CL. 35. REG. 12-14-2004.
- 2,909,741. FEMMEGEMS. INT. CLS. 14 AND 35. REG. 12-14-2004.
- 2,909,743. SPEEDEHELP. INT. CL. 9. REG. 12-14-2004.
- 2,909,744. R.A.P RULES (READING AND PREPARATION). INT. CL. 41. REG. 12-14-2004.
- 2,909,745. THE SCRAP DOCTOR. INT. CLS. 35, 36 AND 40. REG. 12-14-2004.
- 2,909,746. PAYMENTEDGE. INT. CL. 36. REG. 12-14-2004.
- 2,909,748. ECODORA AND DESIGN. INT. CLS. 6, 7, 8 AND 12. REG. 12-14-2004.
- 2,909,749. THE YOUTH PULSE (STYLIZED). INT. CL. 35. REG. 12-14-2004.
- 2,909,750. CORDICATE IT. INT. CLS. 35 AND 42. REG. 12-14-2004.
- 2,909,753. FAST SPRAYERS AND DESIGN. INT. CL. 7. REG. 12-14-2004.
- 2,909,756. GIRLFRIENDS ONLY. INT. CL. 35. REG. 12-14-2004.
- 2,909,759. SKYJET. INT. CL. 9. REG. 12-14-2004.
- 2,909,760. MULTI-WISCH AND DESIGN. INT. CL. 21. REG. 12-14-2004.
- 2,909,761. LINEA AND DESIGN. INT. CL. 21. REG. 12-14-2004.
- 2,909,763. NETSHADOW SERVICES. INT. CL. 42. REG. 12-14-2004.
- 2,909,764. PHARMASEA. INT. CL. 3. REG. 12-14-2004.
- 2,909,765. IMAGINATION MOVERS. INT. CL. 41. REG. 12-14-2004.
- 2,909,773. VERSATILE AND DESIGN. INT. CL. 25. REG. 12-14-2004.
- 2,909,774. FLIPFLOP TRUNKSHOW. INT. CL. 35. REG. 12-14-2004.
- 2,909,776. TACT MEDICAL STAFFING. INT. CL. 35. REG. 12-14-2004.
- 2,909,780. ELECTRONIC EVOLUTIONS. INT. CLS. 35, 37 AND 42. REG. 12-14-2004.
- 2,909,781. E2 AND DESIGN. INT. CLS. 35, 37 AND 42. REG. 12-14-2004.
- 2,909,785. ATLANTA WOMEN'S & CHILDREN'S APPAREL/ ACCESSORIES MARKET. INT. CL. 35. REG. 12-14-2004.
- 2,909,786. ATLANTA MEN'S MARKET. INT. CL. 35. REG. 12-14-2004.
- 2,909,788. NITROMINE. INT. CL. 5. REG. 12-14-2004.
- 2,909,790. KIXZ AND DESIGN. INT. CL. 28. REG. 12-14-2004.
- 2,909,792. DESIGNER SOLARIAN AND DESIGN. INT. CL. 27. REG. 12-14-2004.
- 2,909,794. REACHMASTER. INT. CL. 37. REG. 12-14-2004.
- 2,909,796. NOCOLLECTION. INT. CLS. 18 AND 25. REG. 12-14-2004.
- 2,909,797. OUTLOOK SKATEBOARDS (STYLIZED). INT. CL. 28. REG. 12-14-2004.
- 2,909,798. CORNER AND DESIGN. INT. CL. 34. REG. 12-14-2004.
- 2,909,799. DOOR OPENING SYSTEMS AND DESIGN. INT. CLS. 6 AND 37. REG. 12-14-2004.
- 2,909,802. CORDICATE INFORMATION TECHNOLOGY. INT. CLS. 35 AND 42. REG. 12-14-2004.
- 2,909,803. HANDMASTER. INT. CL. 10. REG. 12-14-2004.
- 2,909,804. FINANCIAL CUSTOMER SERVICE PEOPLE & LEADERSHIP MARKETING PHYSICAL ASSET AND DESIGN. INT. CL. 36. REG. 12-14-2004.

- 2,909,805. MISCELLANEOUS DESIGN. INT. CL. 36. REG. 12-14-2004.
- 2,909,807. LONDON BRIDGE. INT. CL. 32. REG. 12-14-2004.
- 2,909,808. AEROFIS. INT. CLS. 9 AND 38. REG. 12-14-2004.
- 2,909,811. CRITTERS FOR COMPANY. INT. CL. 25. REG. 12-14-2004.
- 2,909,812. OZONO (STYLIZED). INT. CL. 11. REG. 12-14-2004.
- 2,909,815. CEPRO MANAGER. INT. CL. 9. REG. 12-14-2004.
- 2,909,816. AMANI STANDARD CHARACTER MARK. INT. CL. 39. REG. 12-14-2004.
- 2,909,819. AMTS. INT. CL. 42. REG. 12-14-2004.
- 2,909,820. THE GRILLE AT TURTLE POINT. INT. CL. 43. REG. 12-14-2004.
- 2,909,821. MISCELLANEOUS DESIGN. INT. CL. 41. REG. 12-14-2004.
- 2,909,822. TNKFL 5. INT. CL. 25. REG. 12-14-2004.
- 2,909,825. DERN. INT. CLS. 29, 30, 35 AND 43. REG. 12-14-2004.
- 2,909,829. STENTOR AND DESIGN. INT. CL. 9. REG. 12-14-2004.
- 2,909,832. PP PEARLS PLUS (STYLIZED). INT. CL. 14. REG. 12-14-2004.
- 2,909,833. BEHIND EVERY BREAST IS A BEATING HEART. INT. CL. 41. REG. 12-14-2004.
- 2,909,837. THE CARDIOVASCULAR CENTER AT THE GEORGE WASHINGTON UNIVERSITY HOSPITAL AND DESIGN. INT. CL. 44. REG. 12-14-2004.
- 2,909,838. THE CARDIOVASCULAR CENTER AT THE GEORGE WASHINGTON UNIVERSITY HOSPITAL WOMEN'S HEART PROGRAM AND DESIGN. INT. CL. 44. REG. 12-14-2004.
- 2,909,839. FUDOMYO. INT. CL. 9. REG. 12-14-2004.
- 2,909,841. BINARY ARTS. INT. CL. 28. REG. 12-14-2004.
- 2,909,842. STYLUS STUDIO. INT. CL. 42. REG. 12-14-2004.
- 2,909,843. APPSALUTE. INT. CL. 35. REG. 12-14-2004.
- 2,909,845. MISCELLANEOUS DESIGN. INT. CL. 3. REG. 12-14-2004.
- 2,909,848. THE ART OF CHRISTMAS. INT. CL. 41. REG. 12-14-2004.
- 2,909,851. THE CORE PRINCETON AREA RESEARCH CORRIDOR TECHNOLOGY INNOVATION DISCOVERY. INT. CL. 35. REG. 12-14-2004.
- 2,909,852. QUANIX. INT. CL. 9. REG. 12-14-2004.
- 2,909,853. SOFTLAB AND DESIGN. INT. CL. 35. REG. 12-14-2004.
- 2,909,854. SOFTLAB. INT. CL. 42. REG. 12-14-2004.
- 2,909,859. TSUKIMI. INT. CL. 3. REG. 12-14-2004.
- 2,909,862. PASSIONFISH INSPIRED AMERICAN CUISINE AND DESIGN. INT. CL. 43. REG. 12-14-2004.
- 2,909,864. SMARTER DECISIONS WITH FLEET PROGRAMS FOR ACHIEVING FINANCIAL CONFIDENCE. AND DESIGN. INT. CLS. 16 AND 41. REG. 12-14-2004.
- 2,909,865. HEAD TO TOE FOOD LION EXTRA LOW PRICES AND DESIGN. INT. CL. 35. REG. 12-14-2004.
- 2,909,866. THE CORPORATE BEE. INT. CL. 16. REG. 12-14-2004.
- 2,909,867. COPENHAGEN COLLECTIBLES AND DESIGN. INT. CL. 21. REG. 12-14-2004.
- 2,909,870. PALIO COMMUNICATIONS. INT. CL. 35. REG. 12-14-2004.
- 2,909,872. DT DANIELE TRISSI AND DESIGN. INT. CLS. 14 AND 35. REG. 12-14-2004.
- 2,909,874. SEAL JET AND DESIGN. INT. CL. 17. REG. 12-14-2004.
- 2,909,876. KYLIE. INT. CL. 3. REG. 12-14-2004.
- 2,909,877. LOVEKYLIE AND DESIGN. INT. CL. 3. REG. 12-14-2004.
- 2,909,878. GZ (STYLIZED). INT. CL. 18. REG. 12-14-2004.
- 2,909,883. THE SMASHED CHEFS. INT. CL. 21. REG. 12-14-2004.
- 2,909,884. CG AND DESIGN. INT. CL. 35. REG. 12-14-2004.
- 2,909,885. FSB AND DESIGN. INT. CL. 36. REG. 12-14-2004.
- 2,909,886. PRIMETRICA. INT. CL. 35. REG. 12-14-2004.
- 2,909,888. GORILLA TRAILERS, INC. AND DESIGN. INT. CL. 12. REG. 12-14-2004.
- 2,909,890. VOLTE FACE. INT. CL. 3. REG. 12-14-2004.
- 2,909,893. EPC ELECTRONICS PARTNERS CORPORATION AND DESIGN. INT. CL. 40. REG. 12-14-2004.
- 2,909,894. PARK RITE (STYLIZED). INT. CL. 39. REG. 12-14-2004.
- 2,909,895. PARK RITE AND DESIGN. INT. CL. 39. REG. 12-14-2004.
- 2,909,896. WYSE AND DESIGN. INT. CLS. 6 AND 11. REG. 12-14-2004.
- 2,909,901. SERINDA. INT. CLS. 9, 16, 18, 25, 26 AND 35. REG. 12-14-2004.
- 2,909,903. CHUNNELS. INT. CL. 35. REG. 12-14-2004.
- 2,909,905. SANTA BARBARA. INT. CL. 21. REG. 12-14-2004.
- 2,909,907. MEDIPHARM. INT. CL. 44. REG. 12-14-2004.
- 2,909,908. VIETA. INT. CL. 43. REG. 12-14-2004.
- 2,909,909. SILVERTONE. INT. CL. 15. REG. 12-14-2004.
- 2,909,910. WINGS AND DESIGN. INT. CL. 36. REG. 12-14-2004.
- 2,909,911. MAKING GOOD DENTISTRY BETTER. INT. CL. 10. REG. 12-14-2004.
- 2,909,915. SANGRIA ROYALE. INT. CL. 33. REG. 12-14-2004.
- 2,909,917. SPIDER. INT. CL. 9. REG. 12-14-2004.
- 2,909,919. BOGIE AND DESIGN. INT. CL. 19. REG. 12-14-2004.
- 2,909,922. 435. INT. CL. 12. REG. 12-14-2004.
- 2,909,923. 425. INT. CL. 12. REG. 12-14-2004.
- 2,909,925. 430. INT. CL. 12. REG. 12-14-2004.
- 2,909,927. 225. INT. CL. 12. REG. 12-14-2004.
- 2,909,930. NETRS. INT. CL. 9. REG. 12-14-2004.
- 2,909,934. RUN CLEAN RUN FAST. INT. CL. 35. REG. 12-14-2004.
- 2,909,936. FACE IT FASHIONS. INT. CL. 9. REG. 12-14-2004.
- 2,909,939. TRACTION MULTIPLIERS. INT. CL. 28. REG. 12-14-2004.
- 2,909,941. AMERIQUEST MORTGAGE COMPANY AND DESIGN. INT. CL. 36. REG. 12-14-2004.
- 2,909,945. TANGRAM PROGRAM MANAGERS AND DESIGN. INT. CL. 36. REG. 12-14-2004.
- 2,909,946. NA. INT. CL. 20. REG. 12-14-2004.
- 2,909,948. OZMAIL SMART VIDEO EMAIL AND DESIGN. INT. CL. 9. REG. 12-14-2004.
- 2,909,949. NATURAL PERSPECTIVES. INT. CL. 41. REG. 12-14-2004.
- 2,909,952. H2 AND DESIGN. INT. CL. 16. REG. 12-14-2004.
- 2,909,953. DO FUN. INT. CLS. 16, 20, 26 AND 28. REG. 12-14-2004.
- 2,909,955. MOTOR LINK. INT. CL. 16. REG. 12-14-2004.
- 2,909,956. WEAVER OFFICIAL PULICATIONS AND DESIGN. INT. CL. 41. REG. 12-14-2004.
- 2,909,959. VALLEY TRAVELGUARD. INT. CL. 38. REG. 12-14-2004.
- 2,909,961. VC VENTURE COMMUNICATIONS AND DESIGN. INT. CL. 38. REG. 12-14-2004.
- 2,909,962. LEG AFFAIR. INT. CL. 9. REG. 12-14-2004.
- 2,909,963. GOLDEN GIRLS. INT. CL. 9. REG. 12-14-2004.
- 2,909,964. WP4. INT. CL. 4. REG. 12-14-2004.
- 2,909,969. AA AND DESIGN. INT. CL. 14. REG. 12-14-2004.
- 2,909,971. CIARA GROUP. INT. CL. 35. REG. 12-14-2004.
- 2,909,973. HAIR ON WHEELS. INT. CL. 44. REG. 12-14-2004.
- 2,909,974. LIPITOR ATORVASTATIN CALCIUM TABLETS FOR CHOLESTEROL AND DESIGN. INT. CL. 16. REG. 12-14-2004.
- 2,909,976. ZJAZZ COLLECTION. INT. CL. 25. REG. 12-14-2004.
- 2,909,977. SMART COSMETICS. INT. CL. 3. REG. 12-14-2004.
- 2,909,978. WONDER PIZZA ITALY AND DESIGN. INT. CL. 9. REG. 12-14-2004.
- 2,909,981. CRAFT CLUB AND DESIGN. INT. CLS. 16 AND 18. REG. 12-14-2004.
- 2,909,985. FASHIONED IN HIS IMAGE. INT. CLS. 41 AND 44. REG. 12-14-2004.
- 2,909,986. HAIRBALL PICTURES. INT. CL. 41. REG. 12-14-2004.
- 2,909,989. GV GRIFFCO AND DESIGN. INT. CL. 7. REG. 12-14-2004.

- 2,909,990. GEN RE LIFE HEALTH AND DESIGN. INT. CL. 16. REG. 12-14-2004.
- 2,909,993. BABELAND BRIEFS. INT. CL. 41. REG. 12-14-2004.
- 2,909,998. MISCELLANEOUS DESIGN. INT. CL. 29. REG. 12-14-2004.
- 2,909,999. DOPPELGANGER. INT. CL. 31. REG. 12-14-2004.
- 2,910,000. MISCELLANEOUS DESIGN. INT. CL. 36. REG. 12-14-2004.
- 2,910,002. PLATINUM SOLUTIONS GROUP AND DESIGN. INT. CL. 36. REG. 12-14-2004.
- 2,910,003. PRESIDENTIAL LUXURY @ AFFORDABLE PRICES. INT. CL. 37. REG. 12-14-2004.
- 2,910,008. FIT! BY MEDIFAST. INT. CL. 5. REG. 12-14-2004.
- 2,910,009. RE-DENSITY. INT. CL. 3. REG. 12-14-2004.
- 2,910,011. NEW YORK GOURMET HOUSEWARES SHOW. INT. CL. 35. REG. 12-14-2004.
- 2,910,013. GARDEN911. INT. CL. 44. REG. 12-14-2004.
- 2,910,017. MISCELLANEOUS DESIGN. INT. CL. 35. REG. 12-14-2004.
- 2,910,018. UNISA RESORT AND DESIGN. INT. CL. 25. REG. 12-14-2004.
- 2,910,020. W LONG ISLAND WEIGHT LOSS INSTITUTE AND DESIGN. INT. CL. 44. REG. 12-14-2004.
- 2,910,021. DMD. INT. CL. 16. REG. 12-14-2004.
- 2,910,022. H2O SO RIGHT (STYLIZED). INT. CL. 11. REG. 12-14-2004.
- 2,910,024. DIAMONIQUE WEEK STANDARD CHARACTER MARK. INT. CL. 35. REG. 12-14-2004.
- 2,910,025. KRETEKOTE STANDARD CHARACTER MARK. INT. CL. 2. REG. 12-14-2004.
- 2,910,026. PIN HIGH COUNTRY CLUB GOLF (STYLIZED). INT. CL. 9. REG. 12-14-2004.
- 2,910,027. GLENBEIGH STANDARD CHARACTER MARK. INT. CL. 44. REG. 12-14-2004.
- 2,910,028. LEADERS ON THE HORIZON. INT. CL. 41. REG. 12-14-2004.
- 2,910,029. PUREBALANCE FITNESS (STYLIZED). INT. CL. 41. REG. 12-14-2004.
- 2,910,033. SGT OPENING DOORS TO NEW POSSIBILITIES AND DESIGN. INT. CL. 41. REG. 12-14-2004.
- 2,910,037. DOLLAR.COM AND DESIGN. INT. CL. 39. REG. 12-14-2004.
- 2,910,038. COPYWHITE (STYLIZED). INT. CL. 16. REG. 12-14-2004.
- 2,910,040. BORON X-TRA (STYLIZED). INT. CL. 1. REG. 12-14-2004.
- 2,910,042. EL MEXICANO STANDARD CHARACTER MARK. INT. CL. 39. REG. 12-14-2004.
- 2,910,044. ARENA MOIST STANDARD CHARACTER MARK. INT. CL. 1. REG. 12-14-2004.
- 2,910,045. JOEY AND T STANDARD CHARACTER MARK. INT. CL. 25. REG. 12-14-2004.
- 2,910,046. SIEMPRE ESPECIAL STANDARD CHARACTER MARK. INT. CL. 32. REG. 12-14-2004.
- 2,910,047. MIRA! BY CADORE MODA AND DESIGN. INT. CL. 9. REG. 12-14-2004.
- 2,910,050. C.A.S.. INT. CL. 35. REG. 12-14-2004.
- 2,910,051. FORGING STEEL, MAKING HISTORY. INT. CL. 35. REG. 12-14-2004.
- 2,910,052. FOR PLAY UNLIMITED AND DESIGN. INT. CL. 35. REG. 12-14-2004.
- 2,910,054. FARAGHER FAMILY FARM. INT. CL. 30. REG. 12-14-2004.
- 2,910,055. KELLEY ANN (STYLIZED). INT. CL. 25. REG. 12-14-2004.
- 2,910,056. MYCLASSROOMHELPER STANDARD CHARACTER MARK. INT. CL. 42. REG. 12-14-2004.
- 2,910,058. TOMINATOR. INT. CL. 30. REG. 12-14-2004.
- 2,910,060. ARCHIMOVIL (STYLIZED). INT. CL. 20. REG. 12-14-2004.
- 2,910,061. COMPACT-US. INT. CL. 20. REG. 12-14-2004.
- 2,910,062. WHERE FAMILY ENTERTAINING COMES HOME STANDARD CHARACTER MARK. INT. CL. 35. REG. 12-14-2004.
- 2,910,065. PATHWAYS STANDARD CHARACTER MARK. INT. CL. 36. REG. 12-14-2004.
- 2,910,067. BARTCOP STANDARD CHARACTER MARK. INT. CL. 41. REG. 12-14-2004.
- 2,910,068. MISCELLANEOUS DESIGN. INT. CL. 37. REG. 12-14-2004.
- 2,910,069. THE HOMESTRETCH PLAN (STYLIZED). INT. CL. 36. REG. 12-14-2004.
- 2,910,071. SOLSURF STANDARD CHARACTER MARK. INT. CL. 20. REG. 12-14-2004.
- 2,910,072. MARKETPLACE STANDARD CHARACTER MARK. INT. CL. 20. REG. 12-14-2004.
- 2,910,074. ROADMASTER GRILLE STANDARD CHARACTER MARK. INT. CL. 43. REG. 12-14-2004.
- 2,910,075. ANYTIME, ANYWHERE, WITH ANYONE (STYLIZED). INT. CL. 33. REG. 12-14-2004.
- 2,910,076. UNIBEARSTY STANDARD CHARACTER MARK. INT. CL. 16. REG. 12-14-2004.
- 2,910,077. OLIVE U AND DESIGN. INT. CL. 25. REG. 12-14-2004.
- 2,910,079. SHOOT THE FREAK STANDARD CHARACTER MARK. INT. CL. 41. REG. 12-14-2004.
- 2,910,084. KNOWN BY THE COMPANIES WE KEEP STANDARD CHARACTER MARK. INT. CL. 35. REG. 12-14-2004.
- 2,910,086. LIGHTHOUSE (STYLIZED). INT. CL. 3. REG. 12-14-2004.
- 2,910,087. HEY! THAT'S COOL! (STYLIZED). INT. CL. 18. REG. 12-14-2004.
- 2,910,088. FEWER PERIODS. MORE POSSIBILITIES. STANDARD CHARACTER MARK. INT. CL. 5. REG. 12-14-2004.
- 2,910,089. HONEY PIE CLOTHING STANDARD CHARACTER MARK. INT. CL. 25. REG. 12-14-2004.
- 2,910,090. INTELLIBLOCK (STYLIZED). INT. CLS. 38 AND 42. REG. 12-14-2004.
- 2,910,092. INTELICARD (STYLIZED). INT. CL. 35. REG. 12-14-2004.
- 2,910,093. CERTWATCH STANDARD CHARACTER MARK. INT. CL. 42. REG. 12-14-2004.
- 2,910,094. RAW7 AND DESIGN. INT. CL. 25. REG. 12-14-2004.
- 2,910,099. SPRINGBOARD STANDARD CHARACTER MARK. INT. CL. 35. REG. 12-14-2004.
- 2,910,101. TEENS FOR LIFE STANDARD CHARACTER MARK. INT. CL. 16. REG. 12-14-2004.
- 2,910,104. WILDSEED STANDARD CHARACTER MARK. INT. CL. 35. REG. 12-14-2004.
- 2,910,106. NASFT BUYERS' CIRCLE AND DESIGN. INT. CLS. 35 AND 41. REG. 12-14-2004.
- 2,910,109. S'MORES ON THE RUN STANDARD CHARACTER MARK. INT. CL. 30. REG. 12-14-2004.
- 2,910,115. SMILE COMMUNITY STANDARD CHARACTER MARK. INT. CL. 44. REG. 12-14-2004.
- 2,910,120. NETWAVE STANDARD CHARACTER MARK. INT. CL. 10. REG. 12-14-2004.
- 2,910,121. I-TREX AND DESIGN. INT. CL. 36. REG. 12-14-2004.
- 2,910,122. PRIMACY C+AHA STANDARD CHARACTER MARK. INT. CL. 3. REG. 12-14-2004.
- 2,910,123. PRIMACY C+E STANDARD CHARACTER MARK. INT. CL. 3. REG. 12-14-2004.
- 2,910,124. CENTRUE BANK AND DESIGN. INT. CL. 36. REG. 12-14-2004.
- 2,910,125. SMILE COMMUNITY AND DESIGN. INT. CL. 44. REG. 12-14-2004.
- 2,910,126. COMMTRAX STANDARD CHARACTER MARK. INT. CL. 38. REG. 12-14-2004.
- 2,910,127. WEALTHTRAX STANDARD CHARACTER MARK. INT. CL. 41. REG. 12-14-2004.
- 2,910,128. COLD TO THE CORE STANDARD CHARACTER MARK. INT. CL. 21. REG. 12-14-2004.
- 2,910,129. E-KILIVRO (STYLIZED). INT. CL. 5. REG. 12-14-2004.
- 2,910,130. SINAI (STYLIZED). INT. CL. 5. REG. 12-14-2004.
- 2,910,131. BRAXXI (STYLIZED). INT. CL. 5. REG. 12-14-2004.
- 2,910,132. CARVOXIN STANDARD CHARACTER MARK. INT. CL. 5. REG. 12-14-2004.

- 2,910,133. JEMA VISION STANDARD CHARACTER MARK. INT. CL. 9. REG. 12-14-2004.
- 2,910,138. AVIQ STANDARD CHARACTER MARK. INT. CL. 42. REG. 12-14-2004.
- 2,910,144. AVON STANDARD CHARACTER MARK. INT. CL. 5. REG. 12-14-2004.
- 2,910,146. BIG NICKEL STANDARD CHARACTER MARK. INT. CL. 28. REG. 12-14-2004.
- 2,910,148. KNOW YOUR SNUFF STANDARD CHARACTER MARK. INT. CL. 34. REG. 12-14-2004.
- 2,910,150. CENTRAL VALLEY COYOTES STANDARD CHARACTER MARK. INT. CL. 41. REG. 12-14-2004.
- 2,910,156. PARENTING BETTER STUDENTS AND DESIGN. INT. CL. 41. REG. 12-14-2004.
- 2,910,160. C3 STANDARD CHARACTER MARK. INT. CL. 33. REG. 12-14-2004.
- 2,910,161. MISCELLANEOUS DESIGN. INT. CL. 42. REG. 12-14-2004.
- 2,910,162. CUDDLESOFT STANDARD CHARACTER MARK. INT. CLS. 20 AND 24. REG. 12-14-2004.
- 2,910,164. SCAPESAFE STANDARD CHARACTER MARK. INT. CL. 31. REG. 12-14-2004.
- 2,910,165. DR DREAM USA AND DESIGN. INT. CL. 25. REG. 12-14-2004.
- 2,910,166. DR AND DESIGN. INT. CL. 25. REG. 12-14-2004.
- 2,910,168. THE QUALITY IS BUILT IN...NOT ADDED ON STANDARD CHARACTER MARK. INT. CL. 37. REG. 12-14-2004.
- 2,910,169. HAMPTON CRABBERS STANDARD CHARACTER MARK. INT. CL. 25. REG. 12-14-2004.
- 2,910,170. IBRUCE STANDARD CHARACTER MARK. INT. CL. 25. REG. 12-14-2004.
- 2,910,173. REEL GIFTS (STYLIZED). INT. CL. 35. REG. 12-14-2004.
- 2,910,174. THE MIDDLEBRIDGE EXCHANGE STANDARD CHARACTER MARK. INT. CL. 41. REG. 12-14-2004.
- 2,910,176. STEAK DANCE STANDARD CHARACTER MARK. INT. CL. 30. REG. 12-14-2004.
- 2,910,178. SCIENCE CARB H2O STANDARD CHARACTER MARK. INT. CL. 5. REG. 12-14-2004.
- 2,910,182. SEE IT WITH CIT STANDARD CHARACTER MARK. INT. CL. 36. REG. 12-14-2004.
- 2,910,184. RESSOURCE STANDARD CHARACTER MARK. INT. CL. 35. REG. 12-14-2004.
- 2,910,186. LITTLE LIGHTNING STANDARD CHARACTER MARK. INT. CL. 28. REG. 12-14-2004.
- 2,910,187. KLIMACOMFORT AND DESIGN. INT. CL. 25. REG. 12-14-2004.
- 2,910,189. THERMAPHAZ STANDARD CHARACTER MARK. INT. CL. 10. REG. 12-14-2004.
- 2,910,192. THYME SQUARE STANDARD CHARACTER MARK. INT. CL. 43. REG. 12-14-2004.
- 2,910,196. TARGHEE BRANDS GREAT AMERICAN STYLE STANDARD CHARACTER MARK. INT. CL. 29. REG. 12-14-2004.
- 2,910,199. WEALTH AS A DISCIPLINE STANDARD CHARACTER MARK. INT. CL. 36. REG. 12-14-2004.
- 2,910,201. LAMAX (STYLIZED). INT. CL. 25. REG. 12-14-2004.
- 2,910,202. DIONNE (STYLIZED). INT. CL. 25. REG. 12-14-2004.
- 2,910,203. THE SHAPE OF LIES STANDARD CHARACTER MARK. INT. CL. 14. REG. 12-14-2004.
- 2,910,204. SITELINK STANDARD CHARACTER MARK. INT. CL. 9. REG. 12-14-2004.
- 2,910,207. PARK MATE (STYLIZED). INT. CL. 7. REG. 12-14-2004.
- 2,910,208. DIPLOMATS IN EXECUTIVE SEARCH STANDARD CHARACTER MARK. INT. CL. 35. REG. 12-14-2004.
- 2,910,216. WITH YOU WHEN IT MATTERS (STYLIZED). INT. CLS. 36 AND 44. REG. 12-14-2004.
- 2,910,218. LOWRIDER EDGE (STYLIZED). INT. CL. 16. REG. 12-14-2004.
- 2,910,220. ISO-COMFORT STANDARD CHARACTER MARK. INT. CL. 20. REG. 12-14-2004.
- 2,910,221. LESLIE SINGER (STYLIZED). INT. CL. 25. REG. 12-14-2004.
- 2,910,224. IAMSTEEL (STYLIZED). INT. CL. 21. REG. 12-14-2004.
- 2,910,225. MISCELLANEOUS DESIGN. INT. CL. 20. REG. 12-14-2004.
- 2,910,228. HOW TO UNICYCLE AND DESIGN. INT. CL. 41. REG. 12-14-2004.
- 2,910,229. COORDINATION GRAPH PAPER AND DESIGN. INT. CL. 16. REG. 12-14-2004.
- 2,910,231. MISCELLANEOUS DESIGN. INT. CL. 44. REG. 12-14-2004.
- 2,910,232. CLIFF'S EDGE STANDARD CHARACTER MARK. INT. CL. 37. REG. 12-14-2004.
- 2,910,234. READER'S CADDIE (STYLIZED). INT. CL. 16. REG. 12-14-2004.
- 2,910,237. AUTOMODEALS STANDARD CHARACTER MARK. INT. CL. 35. REG. 12-14-2004.
- 2,910,238. SPIRES AND DESIGN. INT. CL. 43. REG. 12-14-2004.
- 2,910,239. APRENDE MK LOGRA, TRIUNFA (STYLIZED). INT. CL. 41. REG. 12-14-2004.
- 2,910,240. LEARN MK ACHIEVE, SUCCCEED (STYLIZED). INT. CL. 41. REG. 12-14-2004.
- 2,910,242. ALPACA LIFE (STYLIZED). INT. CL. 35. REG. 12-14-2004.
- 2,910,243. WWW.A-LIFE.US (STYLIZED). INT. CL. 35. REG. 12-14-2004.
- 2,910,245. EGOSCUE METHOD UNIVERSITY STANDARD CHARACTER MARK. INT. CL. 41. REG. 12-14-2004.
- 2,910,246. MAGNECOTE AND DESIGN. INT. CL. 16. REG. 12-14-2004.
- 2,910,247. STEAG (STYLIZED). INT. CLS. 35, 36, 37, 38, 39, 40, 41, 42 AND 45. REG. 12-14-2004.
- 2,910,249. DEUTSCHE POST. INT. CLS. 16, 25, 28, 36 AND 42. REG. 12-14-2004.
- 2,910,250. CHUPA GURTS. INT. CL. 30. REG. 12-14-2004.
- 2,910,251. VELLOX. INT. CL. 2. REG. 12-14-2004.
- 2,910,253. FCUK AT HOME. INT. CLS. 8, 11, 16, 20, 21, 24 AND 27. REG. 12-14-2004.
- 2,910,254. DEMON INC. (STYLIZED). INT. CL. 16. REG. 12-14-2004.
- 2,910,255. I AND DESIGN. INT. CLS. 9, 35, 36, 41 AND 42. REG. 12-14-2004.
- 2,910,259. SNIFFER. INT. CL. 9. REG. 12-14-2004.
- 2,910,260. INSTANT DVD. INT. CL. 9. REG. 12-14-2004.
- 2,910,261. GIRLS WITH GUITARS. INT. CL. 41. REG. 12-14-2004.
- 2,910,262. AMAZING APES AND DESIGN. INT. CL. 28. REG. 12-14-2004.
- 2,910,263. SCHOOL DISCO. INT. CLS. 9, 38 AND 41. REG. 12-14-2004.
- 2,910,264. MATRIXTN (STYLIZED). INT. CL. 9. REG. 12-14-2004.
- 2,910,265. DP DIGITAL POWER POWERING YOUR TECHNOLOGIES AND DESIGN. INT. CLS. 40 AND 42. REG. 12-14-2004.
- 2,910,266. SUPERMOMS.COM. INT. CL. 35. REG. 12-14-2004.
- 2,910,267. WHERE EAGLES DARE. INT. CLS. 9, 16, 28 AND 41. REG. 12-14-2004.
- 2,910,270. CHUNK INDUSTRIES. INT. CL. 41. REG. 12-14-2004.
- 2,910,271. AMERICAN. INT. CL. 20. REG. 12-14-2004.
- 2,910,272. WORKDIRECTIONS. INT. CLS. 35 AND 41. REG. 12-14-2004.
- 2,910,273. WOORI SECURITIES. INT. CL. 36. REG. 12-14-2004.
- 2,910,274. MEETIC. INT. CLS. 9, 16, 38, 39, 41 AND 45. REG. 12-14-2004.
- 2,910,276. FOR GLOBAL PLAYERS. INT. CL. 12. REG. 12-14-2004.
- 2,910,279. PREMIER. INT. CL. 42. REG. 12-14-2004.
- 2,910,281. EARLY INSIGHT. INT. CLS. 9, 16, 35 AND 44. REG. 12-14-2004.
- 2,910,282. TRANSDEV AND DESIGN. INT. CLS. 35, 36, 39 AND 42. REG. 12-14-2004.

- 2,910,284. CASUAL POINTE. INT. CLS. 24 AND 25. REG. 12-14-2004.
- 2,910,286. MISCELLANEOUS DESIGN. INT. CL. 36. REG. 12-14-2004.
- 2,910,287. TRUST COMPANY. INT. CL. 41. REG. 12-14-2004.
- 2,910,288. KAILAS GLOBAL. INT. CL. 36. REG. 12-14-2004.
- 2,910,289. KAILAS II. INT. CL. 36. REG. 12-14-2004.
- 2,910,290. ROCKS FINE JEWELRY AND DESIGN. INT. CL. 35. REG. 12-14-2004.
- 2,910,291. MEMBERS FIRST FINANCIAL SERVICES FOR EVERYDAY PEOPLE AND DESIGN. INT. CL. 36. REG. 12-14-2004.
- 2,910,292. MARTIN ARCHITECTURAL. INT. CLS. 9, 11, 35, 37 AND 42. REG. 12-14-2004.
- 2,910,293. ADV MUSIC AND DESIGN. INT. CL. 9. REG. 12-14-2004.
- 2,910,294. MISCELLANEOUS DESIGN. INT. CLS. 36 AND 42. REG. 12-14-2004.
- 2,910,295. COLOR SENSIVE. INT. CL. 3. REG. 12-14-2004.
- 2,910,297. NAILISSIMO. INT. CLS. 3 AND 8. REG. 12-14-2004.
- 2,910,299. DECO'S. INT. CLS. 41 AND 43. REG. 12-14-2004.
- 2,910,301. TRAVERSE. INT. CL. 9. REG. 12-14-2004.
- 2,910,304. HOPSPHENON AND DESIGN. INT. CLS. 1, 3, 5, 18, 21, 29, 30, 31, 32 AND 33. REG. 12-14-2004.
- 2,910,305. BEARINGPOINT AND DESIGN. INT. CL. 16. REG. 12-14-2004.
- 2,910,307. BEARINGPOINT AND DESIGN. INT. CL. 36. REG. 12-14-2004.
- 2,910,309. SLEEK CREME (STYLIZED). INT. CL. 3. REG. 12-14-2004.
- 2,910,312. EMETRIX. INT. CL. 35. REG. 12-14-2004.
- 2,910,314. DON ALGODON. INT. CL. 9. REG. 12-14-2004.
- 2,910,315. FIRE TILE AND DESIGN. INT. CL. 19. REG. 12-14-2004.
- 2,910,317. PROSPECT AND DESIGN. INT. CL. 9. REG. 12-14-2004.
- 2,910,327. REPUBLIC OF JAMAICA AND DESIGN. INT. CLS. 25 AND 35. REG. 12-14-2004.
- 2,910,331. TALEMA (STYLIZED). INT. CL. 24. REG. 12-14-2004.
- 2,910,332. CAPBAC. INT. CL. 17. REG. 12-14-2004.
- 2,910,333. COBRA. INT. CLS. 5 AND 10. REG. 12-14-2004.
- 2,910,335. HEARTHSTONE CLASSICS AND DESIGN. INT. CL. 29. REG. 12-14-2004.
- 2,910,336. MONKEYPORN. INT. CL. 41. REG. 12-14-2004.
- 2,910,338. BUTTER TOFFEE THE FAMILIAR CREAMY TASTE IN A CLASSIC TOFFEE CHEW (STYLIZED). INT. CL. 30. REG. 12-14-2004.
- 2,910,341. AIMER TRAINER DELUXE (STYLIZED). INT. CL. 16. REG. 12-14-2004.
- 2,910,344. PEPTOMICS. INT. CLS. 5, 9 AND 42. REG. 12-14-2004.
- 2,910,345. HARLINE. INT. CL. 19. REG. 12-14-2004.
- 2,910,346. FOR RENT AND DESIGN. INT. CL. 36. REG. 12-14-2004.
- 2,910,347. MISCELLANEOUS DESIGN. INT. CL. 16. REG. 12-14-2004.
- 2,910,348. ZANI & CO.. INT. CL. 25. REG. 12-14-2004.
- 2,910,350. 1 INFINITY MINUS ONE AND DESIGN. INT. CL. 9. REG. 12-14-2004.
- 2,910,354. CHASE. INT. CL. 28. REG. 12-14-2004.
- 2,910,357. ICTE. INT. CLS. 9 AND 42. REG. 12-14-2004.
- 2,910,358. OLIVER'S ARTISAN BREADS BREAD TO ENJOY. AND DESIGN. INT. CL. 30. REG. 12-14-2004.
- 2,910,359. CLAVIER TRIO. INT. CL. 41. REG. 12-14-2004.
- 2,910,362. Q AND DESIGN. INT. CL. 44. REG. 12-14-2004.
- 2,910,363. MISCELLANEOUS DESIGN. INT. CL. 16. REG. 12-14-2004.
- 2,910,367. H.U.G.S. HIS UNLIMITED GRACE SAVES. INT. CLS. 6, 14, 16, 18, 21 AND 25. REG. 12-14-2004.
- 2,910,368. NPI (STYLIZED). INT. CL. 42. REG. 12-14-2004.
- 2,910,369. Z ZING AND DESIGN. INT. CL. 3. REG. 12-14-2004.
- 2,910,370. LIBERTY REGIONAL AGENCY MARKETS AND DESIGN. INT. CL. 36. REG. 12-14-2004.
- 2,910,371. VOTHOLE. INT. CL. 8. REG. 12-14-2004.
- 2,910,372. EURICKA. INT. CL. 41. REG. 12-14-2004.
- 2,910,374. SNAKATA. INT. CL. 30. REG. 12-14-2004.
- 2,910,375. QPH QUALIPHARM AND DESIGN. INT. CLS. 41 AND 42. REG. 12-14-2004.
- 2,910,376. EXPRO TEC. INT. CL. 13. REG. 12-14-2004.
- 2,910,378. POLYZENIX. INT. CLS. 1, 10, 40 AND 42. REG. 12-14-2004.
- 2,910,379. YOGALOVE AND DESIGN. INT. CL. 41. REG. 12-14-2004.
- 2,910,381. TESSUTO FILODISCOZIA ALTA QUALITA FABRIC MADE IN ITALY AND DESIGN. INT. CL. 25. REG. 12-14-2004.
- 2,910,382. TCLAND. INT. CLS. 5 AND 42. REG. 12-14-2004.
- 2,910,383. NORDICLEAN. INT. CL. 11. REG. 12-14-2004.
- 2,910,384. BOOMER TWIST SURPRISE AND DESIGN. INT. CL. 30. REG. 12-14-2004.
- 2,910,387. LOWER YOUR INSURANCE COSTS. NOT YOUR EXPECTATIONS. INT. CL. 36. REG. 12-14-2004.
- 2,910,388. MAMAKALL AND DESIGN. INT. CL. 9. REG. 12-14-2004.
- 2,910,389. QUICKCAPTURE. INT. CL. 9. REG. 12-14-2004.
- 2,910,390. ALTAIR. INT. CL. 32. REG. 12-14-2004.
- 2,910,391. TOPPER. INT. CL. 28. REG. 12-14-2004.
- 2,910,393. WORLD ENGINES. INT. CL. 35. REG. 12-14-2004.
- 2,910,398. M12 AND DESIGN. INT. CL. 10. REG. 12-14-2004.
- 2,910,399. SKA SVEIBY KNOWLEDGE ASSOCIATES AND DESIGN. INT. CLS. 16, 35 AND 41. REG. 12-14-2004.
- 2,910,400. ART THIEF. INT. CL. 35. REG. 12-14-2004.
- 2,910,401. LEYLAND AND DESIGN. INT. CLS. 25 AND 28. REG. 12-14-2004.
- 2,910,402. G-PILOT. INT. CL. 9. REG. 12-14-2004.
- 2,910,403. PHOTOMASTER. INT. CL. 1. REG. 12-14-2004.
- 2,910,405. LA MAISON DU CHOCOLAT PARIS AND DESIGN. INT. CL. 30. REG. 12-14-2004.
- 2,910,412. KINJIRUSHI AND DESIGN. INT. CLS. 29 AND 30. REG. 12-14-2004.
- 2,910,414. EAU SAUVAGE CHRISTIAN DIOR PARIS AND DESIGN. INT. CL. 3. REG. 12-14-2004.
- 2,910,417. CAMP ZEBRA AND DESIGN. INT. CL. 41. REG. 12-14-2004.
- 2,910,418. BIALETTI SPAZIO SYSTEM AND DESIGN. INT. CL. 21. REG. 12-14-2004.
- 2,910,419. LEXINGTON ROAD. INT. CL. 41. REG. 12-14-2004.
- 2,910,421. AUTOARM STANDARD CHARACTER MARK. INT. CL. 36. REG. 12-14-2004.
- 2,910,425. IDFLEX3D. INT. CL. 19. REG. 12-14-2004.
- 2,910,426. UTOPIA TAN. INT. CL. 44. REG. 12-14-2004.
- 2,910,428. LE CHENE D'ARGENT. INT. CLS. 29 AND 30. REG. 12-14-2004.
- 2,910,432. ABC'S OF SELF DEFENSE AND DESIGN. INT. CL. 16. REG. 12-14-2004.
- 2,910,433. TREV DEELEY MOTORCYCLE COLLECTION. INT. CL. 41. REG. 12-14-2004.
- 2,910,434. NATUR PRODUKT AND DESIGN. INT. CL. 5. REG. 12-14-2004.
- 2,910,436. SEYBOLD SEMINARS PUBLICATIONS CONSULTING AND DESIGN. INT. CLS. 16, 35 AND 41. REG. 12-14-2004.
- 2,910,440. MEDICSCAN POWERED BY SCANSHELL AND DESIGN. INT. CL. 9. REG. 12-14-2004.
- 2,910,441. SNORT AND DESIGN. INT. CL. 9. REG. 12-14-2004.
- 2,910,443. TEKFLOW (STYLIZED). INT. CLS. 7, 17, 40 AND 42. REG. 12-14-2004.
- 2,910,444. AUBURN FURNACE SERVICES AND DESIGN. INT. CL. 37. REG. 12-14-2004.
- 2,910,445. ROCKTONIC JUICE & COFFEE AND DESIGN. INT. CL. 43. REG. 12-14-2004.
- 2,910,446. BUTONI. INT. CL. 25. REG. 12-14-2004.
- 2,910,447. SELCO AUTO RESOURCE. INT. CL. 36. REG. 12-14-2004.
- 2,910,448. ADVISANT. INT. CLS. 16, 35, 36, 37, 41 AND 42. REG. 12-14-2004.
- 2,910,449. RESEARCH CONNECT. INT. CL. 42. REG. 12-14-2004.

- 2,910,450. CUKIDS AND DESIGN. INT. CL. 36. REG. 12-14-2004.
- 2,910,451. WRITERSEYES.COM. INT. CL. 41. REG. 12-14-2004.
- 2,910,452. KING TUT. INT. CL. 24. REG. 12-14-2004.
- 2,910,455. TOURO TESOURA AND DESIGN. INT. CL. 8. REG. 12-14-2004.
- 2,910,460. EZLINK. INT. CL. 38. REG. 12-14-2004.
- 2,910,461. SIXTOS. INT. CL. 9. REG. 12-14-2004.
- 2,910,463. DISCOVERERS. INT. CLS. 29 AND 30. REG. 12-14-2004.
- 2,910,465. ROSS SWISS DAIRIES. INT. CL. 35. REG. 12-14-2004.
- 2,910,466. EXMAS. INT. CL. 28. REG. 12-14-2004.
- 2,910,468. CHARHOUSE LEARNING. INT. CL. 41. REG. 12-14-2004.
- 2,910,469. CATHOLICS IN ACTION. INT. CL. 45. REG. 12-14-2004.
- 2,910,471. CLEVELAND CLINIC STARIMAGING AND DESIGN. INT. CL. 44. REG. 12-14-2004.
- 2,910,473. FINANCIAL STANDARDS AND DESIGN. INT. CLS. 35 AND 41. REG. 12-14-2004.
- 2,910,474. READYLINK. INT. CLS. 38 AND 42. REG. 12-14-2004.
- 2,910,475. READYLINKS. INT. CLS. 38 AND 42. REG. 12-14-2004.
- 2,910,476. IRG INDEPENDENT RESEARCH GROUP AND DESIGN. INT. CL. 36. REG. 12-14-2004.
- 2,910,477. MISCELLANEOUS DESIGN. INT. CL. 36. REG. 12-14-2004.
- 2,910,478. BLUE PACIFIC AND DESIGN. INT. CL. 42. REG. 12-14-2004.
- 2,910,481. CARIBBEAN BUSINESS WHITE PAGES. INT. CL. 16. REG. 12-14-2004.
- 2,910,483. SMART COMMUTE AND DESIGN. INT. CL. 36. REG. 12-14-2004.
- 2,910,486. BALLANDE. INT. CL. 33. REG. 12-14-2004.
- 2,910,495. NEWGATE. INT. CL. 29. REG. 12-14-2004.
- 2,910,496. TRON. INT. CL. 31. REG. 12-14-2004.
- 2,910,497. DW DREAM WELLNESS AND DESIGN. INT. CL. 44. REG. 12-14-2004.
- 2,910,498. CHEN YU. INT. CL. 3. REG. 12-14-2004.
- 2,910,499. AZULEV MILANIA AND DESIGN. INT. CL. 19. REG. 12-14-2004.
- 2,910,500. SIMPLY STATED AND DESIGN. INT. CL. 44. REG. 12-14-2004.
- 2,910,501. UNISORB. INT. CL. 40. REG. 12-14-2004.
- 2,910,503. ADULT REVENUE SERVICE. INT. CL. 35. REG. 12-14-2004.
- 2,910,505. ANDYG AND DESIGN. INT. CL. 25. REG. 12-14-2004.
- 2,910,506. CUTEYFUL AND DESIGN. INT. CL. 25. REG. 12-14-2004.
- 2,910,508. SKILLS PASSPORT. INT. CL. 42. REG. 12-14-2004.
- 2,910,509. TOBACCO 101 AND DESIGN. INT. CL. 9. REG. 12-14-2004.
- 2,910,510. ADOPT-A-VINE. INT. CLS. 31 AND 33. REG. 12-14-2004.
- 2,910,512. NATIONAL TOWN MEETING ON MAIN STREET. INT. CL. 41. REG. 12-14-2004.
- 2,910,513. TRADEWIND HANDBAGS (STYLIZED). INT. CL. 18. REG. 12-14-2004.
- 2,910,514. IBS AND DESIGN. INT. CLS. 35 AND 40. REG. 12-14-2004.
- 2,910,515. MST. INT. CLS. 9 AND 28. REG. 12-14-2004.
- 2,910,518. VERMILLON. INT. CL. 31. REG. 12-14-2004.
- 2,910,519. ROCK 'N ROLL CAR WASH. INT. CL. 37. REG. 12-14-2004.
- 2,910,521. TENDERHEART AND DESIGN. INT. CL. 29. REG. 12-14-2004.
- 2,910,522. STOP SHOT AND DESIGN. INT. CL. 19. REG. 12-14-2004.
- 2,910,529. BANDBUILDER. INT. CLS. 35, 38 AND 41. REG. 12-14-2004.
- 2,910,532. SOCIEDAD PARA LA COMUNICACION CLARA SOBRE SALUD AND DESIGN. INT. CLS. 16 AND 35. REG. 12-14-2004.
- 2,910,533. PREGÚNTAME 3 (STYLIZED). INT. CLS. 16 AND 35. REG. 12-14-2004.
- 2,910,535. STARRY NIGHT. INT. CL. 9. REG. 12-14-2004.
- 2,910,538. SONIC BOOKS. INT. CL. 9. REG. 12-14-2004.
- 2,910,541. BEACONWORKS. INT. CL. 9. REG. 12-14-2004.
- 2,910,542. TRANSCUT. INT. CLS. 1, 6, 7, 9 AND 42. REG. 12-14-2004.
- 2,910,543. WCIU U TV CHICAGO AND DESIGN. INT. CLS. 38 AND 41. REG. 12-14-2004.
- 2,910,545. HYDRA-TEK (STYLIZED). INT. CL. 22. REG. 12-14-2004.
- 2,910,546. SHOW TECHNOLOGY PRODUCTIONS AND DESIGN. INT. CL. 35. REG. 12-14-2004.
- 2,910,547. CHRIS 1947 DIOR AND DESIGN. INT. CL. 3. REG. 12-14-2004.
- 2,910,549. TELESUITE ENTERPRISE. INT. CL. 38. REG. 12-14-2004.
- 2,910,551. BIG EATS GRILLER SAUSAGE. INT. CL. 29. REG. 12-14-2004.
- 2,910,553. ECLECTIC SKIN INSTITUTE. INT. CL. 41. REG. 12-14-2004.
- 2,910,557. SAFEVIEW DOCUMENT MANAGEMENT SYSTEM AND DESIGN. INT. CL. 9. REG. 12-14-2004.
- 2,910,558. KHRUSTALNY ZVON. INT. CL. 33. REG. 12-14-2004.
- 2,910,559. NEW ENGLAND SENSATION. INT. CL. 41. REG. 12-14-2004.
- 2,910,562. KIDS COUNT. INT. CL. 41. REG. 12-14-2004.
- 2,910,563. MISCELLANEOUS DESIGN. INT. CLS. 35 AND 37. REG. 12-14-2004.
- 2,910,564. A-1 MECHANICAL COMFORT AND CHARACTER YOU CAN DEPEND ON! AND DESIGN. INT. CL. 37. REG. 12-14-2004.
- 2,910,566. B BLUESCAPE ENVIRONMENTAL AND DESIGN. INT. CL. 42. REG. 12-14-2004.
- 2,910,567. MISCELLANEOUS DESIGN. INT. CL. 5. REG. 12-14-2004.
- 2,910,568. TY-1-ON AND DESIGN. INT. CL. 41. REG. 12-14-2004.
- 2,910,569. INSIDER TRAINING. INT. CL. 41. REG. 12-14-2004.
- 2,910,572. NORPRAWN. INT. CL. 29. REG. 12-14-2004.
- 2,910,573. MARIE-LOUISE. INT. CLS. 29 AND 30. REG. 12-14-2004.
- 2,910,574. E AND DESIGN. INT. CL. 16. REG. 12-14-2004.
- 2,910,577. CORDYS BAC (STYLIZED). INT. CLS. 9, 35, 38 AND 42. REG. 12-14-2004.
- 2,910,579. TOTS ON TAPE AND DESIGN. INT. CL. 9. REG. 12-14-2004.
- 2,910,581. HATE TO DOO!. INT. CL. 37. REG. 12-14-2004.
- 2,910,582. BE INSPIRED. INT. CL. 16. REG. 12-14-2004.
- 2,910,584. FOCAL REVIEW. INT. CL. 9. REG. 12-14-2004.
- 2,910,586. HYDRIA SPRINGS, INC. AND DESIGN. INT. CL. 35. REG. 12-14-2004.
- 2,910,587. STRATEGIC EDGE. INT. CLS. 9 AND 35. REG. 12-14-2004.
- 2,910,588. MANGANOX. INT. CLS. 3 AND 5. REG. 12-14-2004.
- 2,910,589. VISIONSCOPE. INT. CL. 9. REG. 12-14-2004.
- 2,910,594. XBEERO. INT. CL. 32. REG. 12-14-2004.
- 2,910,595. HAREMONES. INT. CLS. 16, 21, 25 AND 28. REG. 12-14-2004.
- 2,910,596. TRI-SHIELD STANDARD CHARACTER MARK. INT. CL. 18. REG. 12-14-2004.
- 2,910,597. BUNNIES BY THE BAY. INT. CLS. 20 AND 21. REG. 12-14-2004.
- 2,910,599. GORILLA FUEL MOBILE EQUIPMENT FUELING AND DESIGN. INT. CL. 39. REG. 12-14-2004.
- 2,910,600. EFLECT AND DESIGN. INT. CL. 38. REG. 12-14-2004.
- 2,910,603. AVIDA STRA STANDARD CHARACTER MARK. INT. CLS. 36 AND 37. REG. 12-14-2004.
- 2,910,604. JAGDSTOLZ. INT. CL. 33. REG. 12-14-2004.
- 2,910,605. ECONO TAC AND DESIGN. INT. CL. 1. REG. 12-14-2004.

- 2,910,609. AL WISSAM AND DESIGN. INT. CL. 14. REG. 12-14-2004.
- 2,910,613. PRZETWORZY BABUNI. INT. CL. 29. REG. 12-14-2004.
- 2,910,614. ARROW. INT. CL. 28. REG. 12-14-2004.
- 2,910,616. COURTTV AND DESIGN. INT. CL. 42. REG. 12-14-2004.
- 2,910,618. WASHNET. INT. CL. 9. REG. 12-14-2004.
- 2,910,620. AYELEI AND DESIGN. INT. CL. 35. REG. 12-14-2004.
- 2,910,623. SNOOTY-BOOTS. INT. CLS. 18 AND 25. REG. 12-14-2004.
- 2,910,624. MISCELLANEOUS DESIGN. INT. CL. 39. REG. 12-14-2004.
- 2,910,625. BETONFARBEN - BETONTECHNOLOGIE REMEI AND DESIGN. INT. CL. 1. REG. 12-14-2004.
- 2,910,630. MASTIFF. INT. CL. 12. REG. 12-14-2004.
- 2,910,631. ACCPAC CRM SALESTEAM. INT. CL. 9. REG. 12-14-2004.
- 2,910,632. COSMICALLY COOL. INT. CL. 16. REG. 12-14-2004.
- 2,910,633. COSMICALLY COOL. INT. CL. 28. REG. 12-14-2004.
- 2,910,634. ARTEZ. INT. CL. 42. REG. 12-14-2004.
- 2,910,635. JAZZ BEFORE NINE. INT. CL. 41. REG. 12-14-2004.
- 2,910,637. WEED. INT. CL. 35. REG. 12-14-2004.
- 2,910,639. SPARKLE NIGHT LIGHT (STYLIZED). INT. CL. 11. REG. 12-14-2004.
- 2,910,640. AINOKEA. INT. CL. 25. REG. 12-14-2004.
- 2,910,642. MISCELLANEOUS DESIGN. INT. CL. 16. REG. 12-14-2004.
- 2,910,643. GATOR TECHNOLOGIES AND DESIGN. INT. CL. 42. REG. 12-14-2004.
- 2,910,644. EFY. INT. CL. 25. REG. 12-14-2004.
- 2,910,646. MAYBROOK A TRI-K COMPANY AND DESIGN. INT. CLS. 1 AND 3. REG. 12-14-2004.
- 2,910,649. PERFORMANCE EXCHANGE. INT. CL. 38. REG. 12-14-2004.
- 2,910,650. DERBY DELUXE. INT. CL. 28. REG. 12-14-2004.
- 2,910,651. DERBY DELUXE VIDEO. INT. CL. 28. REG. 12-14-2004.
- 2,910,652. WE BREATHE NEW LIFE INTO DEAD PRODUCT. INT. CL. 35. REG. 12-14-2004.
- 2,910,654. THE BROKEN HEARTS.COM UNRAVELING THE MYSTERIES OF THE OPPOSITE SEX. AND DESIGN. INT. CL. 38. REG. 12-14-2004.
- 2,910,659. IDLETECH (STYLIZED). INT. CL. 35. REG. 12-14-2004.
- 2,910,660. MAJESTÄT. INT. CL. 33. REG. 12-14-2004.
- 2,910,662. CLEARSGHTMEDIA AND DESIGN. INT. CL. 35. REG. 12-14-2004.
- 2,910,663. SEA CHANGE DESIGN PROCESS. INT. CL. 41. REG. 12-14-2004.
- 2,910,666. SOCIETY. INT. CL. 25. REG. 12-14-2004.
- 2,910,668. ESOX COBRA. INT. CL. 28. REG. 12-14-2004.
- 2,910,669. ANIME NETWORK A AND DESIGN. INT. CL. 41. REG. 12-14-2004.
- 2,910,671. KIRY. INT. CL. 30. REG. 12-14-2004.
- 2,910,672. A AND DESIGN. INT. CL. 41. REG. 12-14-2004.
- 2,910,673. J. C. BILLIARDS AND DESIGN. INT. CL. 35. REG. 12-14-2004.
- 2,910,677. NIMESA. INT. CL. 9. REG. 12-14-2004.
- 2,910,678. MINI BUFFER STANDARD CHARACTER MARK. INT. CL. 7. REG. 12-14-2004.
- 2,910,680. SNOW KING. INT. CL. 41. REG. 12-14-2004.
- 2,910,681. HOW TO MAKE A BED. INT. CL. 24. REG. 12-14-2004.
- 2,910,683. MISCELLANEOUS DESIGN. INT. CL. 17. REG. 12-14-2004.
- 2,910,684. MISCELLANEOUS DESIGN. INT. CL. 37. REG. 12-14-2004.
- 2,910,685. MISCELLANEOUS DESIGN. INT. CL. 41. REG. 12-14-2004.
- 2,910,686. YOUR GUIDING LIGHT TO REAL ESTATE. INT. CL. 16. REG. 12-14-2004.
- 2,910,689. ROBOT/TRANSFORM. INT. CL. 9. REG. 12-14-2004.
- 2,910,690. HALLOWEEN SCENE AND DESIGN. INT. CLS. 25 AND 35. REG. 12-14-2004.
- 2,910,691. MILLIONAIRE MADNESS (STYLIZED). INT. CLS. 28 AND 35. REG. 12-14-2004.
- 2,910,693. LEVTECH. INT. CL. 7. REG. 12-14-2004.
- 2,910,694. SAFE DREAMS. INT. CL. 20. REG. 12-14-2004.
- 2,910,698. PLUS QU'UN ROUGE. INT. CL. 3. REG. 12-14-2004.
- 2,910,699. SIGNATURE AND DESIGN. INT. CL. 35. REG. 12-14-2004.
- 2,910,700. SURFCULT AND DESIGN. INT. CLS. 9, 18 AND 25. REG. 12-14-2004.
- 2,910,701. EPK. INT. CLS. 25 AND 35. REG. 12-14-2004.
- 2,910,704. INSIGHT NMS. INT. CL. 9. REG. 12-14-2004.
- 2,910,705. TIPS AND DESIGN. INT. CLS. 13, 35 AND 42. REG. 12-14-2004.
- 2,910,708. BOCCAGE. INT. CL. 3. REG. 12-14-2004.
- 2,910,711. IMPERIAL LEATHER. INT. CL. 3. REG. 12-14-2004.
- 2,910,712. REJUVENOX. INT. CL. 1. REG. 12-14-2004.
- 2,910,714. NAMEMYTUNE. INT. CLS. 41 AND 42. REG. 12-14-2004.
- 2,910,718. TIMELYBILL. INT. CL. 9. REG. 12-14-2004.
- 2,910,720. THE BIBLE BOOK AND DESIGN. INT. CL. 9. REG. 12-14-2004.
- 2,910,724. SOLAR FREEDOM. INT. CL. 12. REG. 12-14-2004.
- 2,910,727. MISCELLANEOUS DESIGN. INT. CL. 9. REG. 12-14-2004.
- 2,910,728. POWER MEMORY AND DESIGN. INT. CL. 41. REG. 12-14-2004.
- 2,910,729. NOTESYSTEM. INT. CL. 7. REG. 12-14-2004.
- 2,910,731. IDENTIFIER (STYLIZED). INT. CLS. 42 AND 44. REG. 12-14-2004.
- 2,910,734. SUKANO AND DESIGN. INT. CLS. 1 AND 17. REG. 12-14-2004.
- 2,910,739. PANSTAR. INT. CL. 5. REG. 12-14-2004.
- 2,910,740. SICRAMON. INT. CL. 5. REG. 12-14-2004.
- 2,910,743. BG AND DESIGN. INT. CL. 36. REG. 12-14-2004.
- 2,910,745. AMBIEN PAK. INT. CL. 5. REG. 12-14-2004.
- 2,910,749. TM AND DESIGN. INT. CL. 9. REG. 12-14-2004.
- 2,910,752. SIEGO. INT. CL. 9. REG. 12-14-2004.
- 2,910,753. ANDRÉ MEYER VENTURES STANDARD CHARACTER MARK. INT. CL. 36. REG. 12-14-2004.
- 2,910,754. MISCELLANEOUS DESIGN. INT. CL. 36. REG. 12-14-2004.
- 2,910,755. BARELE AND DESIGN. INT. CL. 44. REG. 12-14-2004.
- 2,910,756. TEXAS TAN AND DESIGN. INT. CL. 44. REG. 12-14-2004.
- 2,910,758. AMERICAN BUILDER. INT. CL. 8. REG. 12-14-2004.
- 2,910,764. REPRESENTATIONS. INT. CL. 35. REG. 12-14-2004.
- 2,910,765. PLAY SEVEN. INT. CL. 41. REG. 12-14-2004.
- 2,910,766. BRAINSTORM STUDIOS LLC AND DESIGN. INT. CL. 42. REG. 12-14-2004.
- 2,910,767. TWIN BEAKS AND DESIGN. INT. CL. 33. REG. 12-14-2004.
- 2,910,768. CENTRICATA SIMPLIFY.ONLINE AND DESIGN. INT. CL. 42. REG. 12-14-2004.
- 2,910,769. INSIGHT PARTNERS. INT. CLS. 41 AND 42. REG. 12-14-2004.
- 2,910,771. BENVINDA. INT. CL. 33. REG. 12-14-2004.
- 2,910,773. BUSINESS PROPELLERS. INT. CL. 35. REG. 12-14-2004.
- 2,910,774. IT'S ONLY NATURAL. INT. CLS. 36, 37, 41 AND 43. REG. 12-14-2004.
- 2,910,775. BUSCOPAN. INT. CL. 5. REG. 12-14-2004.
- 2,910,776. BUSCAPINA. INT. CL. 5. REG. 12-14-2004.
- 2,910,778. BUZZ BAG AND DESIGN. INT. CL. 21. REG. 12-14-2004.
- 2,910,780. ZAY ZAY. INT. CLS. 9 AND 41. REG. 12-14-2004.
- 2,910,785. SLY DOG. INT. CL. 41. REG. 12-14-2004.
- 2,910,787. CAFE CON LECHE. INT. CL. 36. REG. 12-14-2004.
- 2,910,788. MODALYST. INT. CLS. 9 AND 38. REG. 12-14-2004.

- 2,910,791. COURSEBROWSER.COM. INT. CL. 35. REG. 12-14-2004.
- 2,910,792. ARMOR. INT. CLS. 4 AND 9. REG. 12-14-2004.
- 2,910,794. PAI WOW BONUS. INT. CL. 41. REG. 12-14-2004.
- 2,910,796. ALPHA SUN. INT. CL. 11. REG. 12-14-2004.
- 2,910,797. GET WIRED, GET HIRED. (STYLIZED). INT. CL. 35. REG. 12-14-2004.
- 2,910,798. MESOPROII. INT. CL. 5. REG. 12-14-2004.
- 2,910,799. VISIONOPS WE DELIVER CLIENT VISIONOPS CENTERS AND DESIGN. INT. CLS. 35 AND 41. REG. 12-14-2004.
- 2,910,806. SNOW SOCKS. INT. CL. 25. REG. 12-14-2004.
- 2,910,807. LONGABERGER UNIVERSITY. INT. CL. 41. REG. 12-14-2004.
- 2,910,808. SUSAN LANDAU DESIGNS. INT. CL. 35. REG. 12-14-2004.
- 2,910,809. CONSOLE SKIN. INT. CL. 16. REG. 12-14-2004.
- 2,910,810. WINE WIKKET (STYLIZED). INT. CL. 21. REG. 12-14-2004.
- 2,910,811. THOROUGHLY WASHED FRESH FROM NATURE AND DESIGN. INT. CL. 29. REG. 12-14-2004.
- 2,910,815. KEITH DANIELS (STYLIZED). INT. CL. 25. REG. 12-14-2004.
- 2,910,817. VIVAGEN HEALTH PRODUCTS AND DESIGN. INT. CL. 35. REG. 12-14-2004.
- 2,910,821. MYSTERY REEL ACTION AND DESIGN. INT. CL. 9. REG. 12-14-2004.
- 2,910,822. CUSTOM EDUCREDIT. INT. CL. 36. REG. 12-14-2004.
- 2,910,823. NEXTSTEP RESOURCES. INT. CL. 35. REG. 12-14-2004.
- 2,910,825. POISE PANTLINERS AND DESIGN. INT. CL. 5. REG. 12-14-2004.
- 2,910,826. POISE PADS AND DESIGN. INT. CL. 5. REG. 12-14-2004.
- 2,910,829. SANTA BARBARA SOYMILK STANDARD CHARACTER MARK. INT. CL. 29. REG. 12-14-2004.
- 2,910,832. ASCENSION ENTERTAINMENT. INT. CLS. 4 AND 9. REG. 12-14-2004.
- 2,910,834. MISCELLANEOUS DESIGN. INT. CL. 10. REG. 12-14-2004.
- 2,910,835. LMS LMS INTELLIBOUND INC AND DESIGN. INT. CL. 39. REG. 12-14-2004.
- 2,910,837. BBQ MATES. INT. CL. 29. REG. 12-14-2004.
- 2,910,838. DITRIPENTAT. INT. CL. 5. REG. 12-14-2004.
- 2,910,841. MAMMO-GUARD. INT. CL. 5. REG. 12-14-2004.
- 2,910,846. CED AND DESIGN. INT. CL. 41. REG. 12-14-2004.
- 2,910,851. BLACKBAG AND DESIGN. INT. CLS. 9 AND 42. REG. 12-14-2004.
- 2,910,852. SHAPE EN ESPANOL. INT. CL. 16. REG. 12-14-2004.
- 2,910,854. 2 SCOOPS CAFE. INT. CL. 43. REG. 12-14-2004.
- 2,910,855. ZAP LURES AND DESIGN. INT. CL. 28. REG. 12-14-2004.
- 2,910,858. CORPORATEEXPRESSDOCUMENTS. INT. CL. 35. REG. 12-14-2004.
- 2,910,862. QUIS CUSTODIET IPSOS CUSTODES AND DESIGN. INT. CL. 42. REG. 12-14-2004.
- 2,910,863. IMPACT. INT. CL. 9. REG. 12-14-2004.
- 2,910,864. COSMABELLA. INT. CL. 44. REG. 12-14-2004.
- 2,910,869. SILVERFAST HDR (STYLIZED). INT. CL. 9. REG. 12-14-2004.
- 2,910,874. SNACKS. INT. CL. 41. REG. 12-14-2004.
- 2,910,875. MISCELLANEOUS DESIGN. INT. CL. 42. REG. 12-14-2004.
- 2,910,877. OLIVER WEBER COLLECTION. INT. CL. 14. REG. 12-14-2004.
- 2,910,880. ADVANCED PHYSICIAN SOLUTIONS AND DESIGN. INT. CL. 35. REG. 12-14-2004.
- 2,910,882. ALLIED ENERGY GROUP. INT. CLS. 40 AND 42. REG. 12-14-2004.
- 2,910,883. WELLAM. INT. CL. 36. REG. 12-14-2004.
- 2,910,885. WATER POINTE REALTY GROUP. INT. CL. 36. REG. 12-14-2004.
- 2,910,886. FOODNET. INT. CL. 39. REG. 12-14-2004.
- 2,910,888. SOBE MACLIZARD'S SPECIAL RECIPE LEMONADE AND DESIGN. INT. CL. 32. REG. 12-14-2004.
- 2,910,889. SOBE ENERGY AND DESIGN. INT. CL. 32. REG. 12-14-2004.
- 2,910,893. FUEL THE FIRE. INT. CL. 25. REG. 12-14-2004.
- 2,910,894. DIGITAL CURTAIN AND DESIGN. INT. CL. 9. REG. 12-14-2004.
- 2,910,899. MISCELLANEOUS DESIGN. INT. CL. 25. REG. 12-14-2004.
- 2,910,900. ECARTDELUXE. INT. CL. 42. REG. 12-14-2004.
- 2,910,902. VERBAL POWER STANDARD CHARACTER MARK. INT. CL. 9. REG. 12-14-2004.
- 2,910,905. GAMES ON THE GO STANDARD CHARACTER MARK. INT. CL. 28. REG. 12-14-2004.
- 2,910,906. MISCELLANEOUS DESIGN. INT. CL. 44. REG. 12-14-2004.
- 2,910,908. PROVIDENCE PARTNERS STANDARD CHARACTER MARK. INT. CLS. 36 AND 37. REG. 12-14-2004.
- 2,910,909. EASYBOND STANDARD CHARACTER MARK. INT. CL. 1. REG. 12-14-2004.
- 2,910,910. PEGSTOUR STANDARD CHARACTER MARK. INT. CL. 38. REG. 12-14-2004.
- 2,910,914. "BUILDING TRUST...ENRICHING LIVES." (STYLIZED). INT. CL. 36. REG. 12-14-2004.
- 2,910,918. USGI MEDICAL STANDARD CHARACTER MARK. INT. CL. 10. REG. 12-14-2004.
- 2,910,920. JACMAC SCOOTERS STANDARD CHARACTER MARK. INT. CL. 35. REG. 12-14-2004.
- 2,910,922. ECO PIT STANDARD CHARACTER MARK. INT. CL. 37. REG. 12-14-2004.
- 2,910,923. SOS CHARGER AND DESIGN. INT. CL. 9. REG. 12-14-2004.
- 2,910,926. EDUARDO BASSONI STANDARD CHARACTER MARK. INT. CL. 25. REG. 12-14-2004.
- 2,910,927. EK STANDARD CHARACTER MARK. INT. CL. 14. REG. 12-14-2004.
- 2,910,928. TEKETERA STANDARD CHARACTER MARK. INT. CL. 42. REG. 12-14-2004.
- 2,910,929. CABLE VEIL STANDARD CHARACTER MARK. INT. CL. 9. REG. 12-14-2004.
- 2,910,934. WF WORLD'S FINEST CHOCOLATE AND DESIGN. INT. CL. 30. REG. 12-14-2004.
- 2,910,935. BILL BLASS NEW YORK STANDARD CHARACTER MARK. INT. CL. 25. REG. 12-14-2004.
- 2,910,936. SWEET WILLOW BAY STANDARD CHARACTER MARK. INT. CL. 16. REG. 12-14-2004.
- 2,910,939. PHANTOM STANDARD CHARACTER MARK. INT. CL. 34. REG. 12-14-2004.
- 2,910,942. THERE'S ALWAYS MORE ONLINE STANDARD CHARACTER MARK. INT. CL. 35. REG. 12-14-2004.
- 2,910,947. QWEST FREEDOM STANDARD CHARACTER MARK. INT. CL. 38. REG. 12-14-2004.
- 2,910,948. AFTER SCHOOL MARTIAL ARTS P.L.U.S. STANDARD CHARACTER MARK. INT. CL. 41. REG. 12-14-2004.
- 2,910,949. CHENG-TA AND DESIGN. INT. CL. 33. REG. 12-14-2004.
- 2,910,951. NITELIFE LEATHER INTERNATIONAL AND DESIGN. INT. CL. 18. REG. 12-14-2004.
- 2,910,955. SIMULATED PRESENCE STANDARD CHARACTER MARK. INT. CL. 44. REG. 12-14-2004.
- 2,910,957. THE IDGAFA SOCIETY STANDARD CHARACTER MARK. INT. CL. 25. REG. 12-14-2004.
- 2,910,958. TRAINED HUMAN STANDARD CHARACTER MARK. INT. CL. 41. REG. 12-14-2004.
- 2,910,959. SCHWAB INSTITUTIONAL RESEARCH IN OUR VIEW STANDARD CHARACTER MARK. INT. CLS. 9 AND 16. REG. 12-14-2004.
- 2,910,961. LIFEEXCELLENCE STANDARD CHARACTER MARK. INT. CL. 41. REG. 12-14-2004.
- 2,910,962. DREAMESTATES.COM AND DESIGN. INT. CL. 36. REG. 12-14-2004.
- 2,910,963. DUALCORD STANDARD CHARACTER MARK. INT. CL. 28. REG. 12-14-2004.

- 2,910,965. EARTHSTYLE STANDARD CHARACTER MARK. INT. CL. 14. REG. 12-14-2004.
- 2,910,968. BULLDOG STANDARD CHARACTER MARK. INT. CL. 16. REG. 12-14-2004.
- 2,910,969. ARNOLD'S LOBSTER & CLAM BAR AND DESIGN. INT. CL. 43. REG. 12-14-2004.
- 2,910,972. UNITED WE SAND AND DESIGN. INT. CLS. 16, 20 AND 25. REG. 12-14-2004.
- 2,910,973. DUNES CLUB STANDARD CHARACTER MARK. INT. CLS. 18 AND 20. REG. 12-14-2004.
- 2,910,976. BUCKET AND DESIGN. INT. CL. 25. REG. 12-14-2004.
- 2,910,978. MISCELLANEOUS DESIGN. INT. CL. 37. REG. 12-14-2004.
- 2,910,979. INNERVIEW STANDARD CHARACTER MARK. INT. CL. 9. REG. 12-14-2004.
- 2,910,981. NYC PEACH STANDARD CHARACTER MARK. INT. CLS. 9 AND 21. REG. 12-14-2004.
- 2,910,984. GUNPLATE STANDARD CHARACTER MARK. INT. CL. 37. REG. 12-14-2004.
- 2,910,987. NETSPARES STANDARD CHARACTER MARK. INT. CLS. 37, 38 AND 42. REG. 12-14-2004.
- 2,910,988. HBPack STANDARD CHARACTER MARK. INT. CL. 18. REG. 12-14-2004.
- 2,910,990. SOLUS AND DESIGN. INT. CL. 35. REG. 12-14-2004.
- 2,910,993. FORMULA 33 STANDARD CHARACTER MARK. INT. CL. 1. REG. 12-14-2004.
- 2,910,995. COTHRIVE STANDARD CHARACTER MARK. INT. CL. 35. REG. 12-14-2004.
- 2,910,998. CLASSICAL SPECTACULAR STANDARD CHARACTER MARK. INT. CLS. 9, 16 AND 41. REG. 12-14-2004.
- 2,911,000. BRIDGESITE CLINICAL RESEARCH STANDARD CHARACTER MARK. INT. CL. 42. REG. 12-14-2004.
- 2,911,001. NEW ENGLAND COOKS STANDARD CHARACTER MARK. INT. CL. 41. REG. 12-14-2004.
- 2,911,002. ABEL'S LOBSTER POUND STANDARD CHARACTER MARK. INT. CL. 43. REG. 12-14-2004.
- 2,911,010. MISCELLANEOUS DESIGN. INT. CL. 25. REG. 12-14-2004.
- 2,911,011. PEACE OF MIND PERSONAL INVENTORY STANDARD CHARACTER MARK. INT. CL. 16. REG. 12-14-2004.
- 2,911,012. ZINGIS STANDARD CHARACTER MARK. INT. CLS. 1 AND 5. REG. 12-14-2004.
- 2,911,014. AMERICAN DEVILS STANDARD CHARACTER MARK. INT. CL. 41. REG. 12-14-2004.
- 2,911,019. CAMBROSIA STANDARD CHARACTER MARK. INT. CL. 42. REG. 12-14-2004.
- 2,911,020. RECETO STANDARD CHARACTER MARK. INT. CLS. 1 AND 5. REG. 12-14-2004.
- 2,911,021. TAJFEST STANDARD CHARACTER MARK. INT. CL. 41. REG. 12-14-2004.
- 2,911,023. FEDMED FEDERAL MEDICAL AND DESIGN. INT. CL. 36. REG. 12-14-2004.
- 2,911,026. G.U.S. STANDARD CHARACTER MARK. INT. CL. 9. REG. 12-14-2004.
- 2,911,027. SPLENDID SPA STANDARD CHARACTER MARK. INT. CL. 3. REG. 12-14-2004.
- 2,911,029. NEW YORK LASIK VISION CORRECTION STANDARD CHARACTER MARK. INT. CL. 44. REG. 12-14-2004.
- 2,911,032. CHAMELEON.NET STANDARD CHARACTER MARK. INT. CL. 42. REG. 12-14-2004.
- 2,911,035. BIRTHOLOGY THE REALITIES OF CHILD-BIRTH AND DESIGN. INT. CL. 16. REG. 12-14-2004.
- 2,911,039. ANGEL HANDS HEALING STANDARD CHARACTER MARK. INT. CL. 41. REG. 12-14-2004.
- 2,911,040. ARE YOU COMPATIBLE? STANDARD CHARACTER MARK. INT. CL. 42. REG. 12-14-2004.
- 2,911,045. LIFEXPAND STANDARD CHARACTER MARK. INT. CL. 5. REG. 12-14-2004.
- 2,911,046. CARDIACMD STANDARD CHARACTER MARK. INT. CL. 42. REG. 12-14-2004.
- 2,911,049. JUMPIES INFLATABLE RENTALS (STYLIZED). INT. CL. 41. REG. 12-14-2004.
- 2,911,051. INGENIX FACILITYALERT STANDARD CHARACTER MARK. INT. CL. 35. REG. 12-14-2004.
- 2,911,053. HOLLA BOYZ STANDARD CHARACTER MARK. INT. CL. 41. REG. 12-14-2004.
- 2,911,058. HATCHBACK STANDARD CHARACTER MARK. INT. CL. 16. REG. 12-14-2004.
- 2,911,063. DEALERSPHERE STANDARD CHARACTER MARK. INT. CLS. 35 AND 42. REG. 12-14-2004.
- 2,911,066. WINDIP STANDARD CHARACTER MARK. INT. CL. 5. REG. 12-14-2004.
- 2,911,067. HEADACHEFREE STANDARD CHARACTER MARK. INT. CL. 5. REG. 12-14-2004.
- 2,911,068. BETTER COMMUNICATION THROUGH COLLABORATION STANDARD CHARACTER MARK. INT. CL. 35. REG. 12-14-2004.
- 2,911,070. AREA.CODES.UNPLUGGED STANDARD CHARACTER MARK. INT. CL. 25. REG. 12-14-2004.
- 2,911,071. (ACU) AREA.CODES.UNPLUGGED AND DESIGN. INT. CL. 25. REG. 12-14-2004.
- 2,911,072. ALWAYS NEW ALWAYS FOR LESS STANDARD CHARACTER MARK. INT. CL. 35. REG. 12-14-2004.
- 2,911,073. AIRBRUSH CITY STANDARD CHARACTER MARK. INT. CL. 7. REG. 12-14-2004.
- 2,911,074. MISCELLANEOUS DESIGN. INT. CL. 36. REG. 12-14-2004.
- 2,911,076. GASTRIC GOLD STANDARD CHARACTER MARK. INT. CL. 5. REG. 12-14-2004.
- 2,911,078. MISCELLANEOUS DESIGN. INT. CL. 42. REG. 12-14-2004.
- 2,911,079. CLEVER HOMES STANDARD CHARACTER MARK. INT. CL. 37. REG. 12-14-2004.
- 2,911,080. TAKE THE RED PILL STANDARD CHARACTER MARK. INT. CL. 5. REG. 12-14-2004.
- 2,911,081. A HEALTHCARE NETWORK WHERE YOU NEED IT STANDARD CHARACTER MARK. INT. CL. 44. REG. 12-14-2004.
- 2,911,084. HIGHLY PROVEN HIGHLY TESTED STANDARD CHARACTER MARK. INT. CL. 7. REG. 12-14-2004.
- 2,911,087. AMPLIFIERS MADE SIMPLE STANDARD CHARACTER MARK. INT. CL. 42. REG. 12-14-2004.
- 2,911,089. AT THE INTERSECTION OF SPEED AND ACCURACY STANDARD CHARACTER MARK. INT. CL. 42. REG. 12-14-2004.
- 2,911,092. TRIBAL ACCUPAX STANDARD CHARACTER MARK. INT. CL. 35. REG. 12-14-2004.
- 2,911,097. BRATZ BOYZ AND DESIGN. INT. CL. 28. REG. 12-14-2004.
- 2,911,098. 100 WAYS IN 30 DAYS TO SAVE WATER STANDARD CHARACTER MARK. INT. CL. 35. REG. 12-14-2004.
- 2,911,099. AH-HA VOCABULARY AND DESIGN. INT. CL. 16. REG. 12-14-2004.
- 2,911,105. MISCELLANEOUS DESIGN. INT. CL. 9. REG. 12-14-2004.
- 2,911,106. CASPIAN STANDARD CHARACTER MARK. INT. CL. 11. REG. 12-14-2004.
- 2,911,107. LEAD LIKE JESUS (STYLIZED). INT. CL. 41. REG. 12-14-2004.
- 2,911,110. TRANSCEND REALTY AND DEVELOPMENT STANDARD CHARACTER MARK. INT. CLS. 36 AND 37. REG. 12-14-2004.
- 2,911,112. SPIFF IT STANDARD CHARACTER MARK. INT. CL. 35. REG. 12-14-2004.
- 2,911,114. COLLEGIATE LEGENDS STANDARD CHARACTER MARK. INT. CL. 25. REG. 12-14-2004.
- 2,911,116. FRIENDS 2B MADE AND DESIGN. INT. CL. 28. REG. 12-14-2004.
- 2,911,119. DIAROMEDIA STANDARD CHARACTER MARK. INT. CL. 9. REG. 12-14-2004.
- 2,911,121. FRIENDS 2B MADE AND DESIGN. INT. CL. 35. REG. 12-14-2004.

- 2,911,123. WORK EARN DRIVE STANDARD CHARACTER MARK. INT. CL. 36. REG. 12-14-2004.
- 2,911,127. BLITZ STANDARD CHARACTER MARK. INT. CL. 28. REG. 12-14-2004.
- 2,911,128. POOLHUB STANDARD CHARACTER MARK. INT. CL. 35. REG. 12-14-2004.
- 2,911,129. ALPHA Z STANDARD CHARACTER MARK. INT. CL. 12. REG. 12-14-2004.
- 2,911,130. EXPERIENCE OUR PASSION! STANDARD CHARACTER MARK. INT. CL. 35. REG. 12-14-2004.
- 2,911,132. SILICON SEMICONDUCTOR AND DESIGN. INT. CL. 9. REG. 12-14-2004.
- 2,911,140. JAX WARRIORS STANDARD CHARACTER MARK. INT. CL. 41. REG. 12-14-2004.
- 2,911,142. NU-TEMP STANDARD CHARACTER MARK. INT. CL. 9. REG. 12-14-2004.
- 2,911,144. TECHNOLOGY OF STILLNESS STANDARD CHARACTER MARK. INT. CL. 41. REG. 12-14-2004.
- 2,911,145. GOOD HANDS STANDARD CHARACTER MARK. INT. CL. 35. REG. 12-14-2004.
- 2,911,146. GEORGIAN LEGEND STANDARD CHARACTER MARK. INT. CL. 9. REG. 12-14-2004.
- 2,911,150. WONDERBRA LOVE IT LACE STANDARD CHARACTER MARK. INT. CL. 25. REG. 12-14-2004.
- 2,911,153. CEXI STANDARD CHARACTER MARK. INT. CLS. 3 AND 14. REG. 12-14-2004.
- 2,911,156. IRONCO AND DESIGN. INT. CL. 40. REG. 12-14-2004.
- 2,911,157. COLORADO 7'S STANDARD CHARACTER MARK. INT. CL. 28. REG. 12-14-2004.
- 2,911,159. TOURSTREAM AND DESIGN. INT. CL. 12. REG. 12-14-2004.
- 2,911,160. TOURSTREAM AND DESIGN. INT. CL. 25. REG. 12-14-2004.
- 2,911,161. POWERED BY CONNECTICUT INGENUITY STANDARD CHARACTER MARK. INT. CL. 35. REG. 12-14-2004.
- 2,911,164. GROOVE FEVER STANDARD CHARACTER MARK. INT. CL. 9. REG. 12-14-2004.
- 2,911,165. AMERIZONE STANDARD CHARACTER MARK. INT. CL. 42. REG. 12-14-2004.
- 2,911,166. PUSHIN DAISIES STANDARD CHARACTER MARK. INT. CL. 35. REG. 12-14-2004.
- 2,911,169. STRI VERA STANDARD CHARACTER MARK. INT. CL. 3. REG. 12-14-2004.
- 2,911,173. MASTER THE TAX GAME STANDARD CHARACTER MARK. INT. CL. 9. REG. 12-14-2004.
- 2,911,174. COTTONWOOD HILLS AND DESIGN. INT. CL. 37. REG. 12-14-2004.
- 2,911,175. ANNIE LYNN (STYLIZED). INT. CL. 25. REG. 12-14-2004.
- 2,911,177. OTRS-MD STANDARD CHARACTER MARK. INT. CL. 44. REG. 12-14-2004.
- 2,911,178. DIEHARD STANDARD CHARACTER MARK. INT. CL. 12. REG. 12-14-2004.
- 2,911,180. COUNTRY WAY STANDARD CHARACTER MARK. INT. CL. 31. REG. 12-14-2004.
- 2,911,186. GIVINGMORE.COM (STYLIZED). INT. CL. 36. REG. 12-14-2004.
- 2,911,189. NAUGHTY COWGIRL STANDARD CHARACTER MARK. INT. CL. 25. REG. 12-14-2004.
- 2,911,190. BRING YOUR MOUSE TO OUR HOUSE!! STANDARD CHARACTER MARK. INT. CL. 42. REG. 12-14-2004.
- 2,911,191. FONECA STANDARD CHARACTER MARK. INT. CL. 38. REG. 12-14-2004.
- 2,911,193. SKYE'S THE LIMIT STANDARD CHARACTER MARK. INT. CL. 14. REG. 12-14-2004.
- 2,911,194. SUN LIKE STANDARD CHARACTER MARK. INT. CL. 3. REG. 12-14-2004.
- 2,911,195. FULFILL A CHILD'S DREAM STANDARD CHARACTER MARK. INT. CL. 36. REG. 12-14-2004.
- 2,911,196. VALUERAT AND DESIGN. INT. CL. 35. REG. 12-14-2004.
- 2,911,202. STAY CALM STANDARD CHARACTER MARK. INT. CL. 3. REG. 12-14-2004.
- 2,911,203. MESH STANDARD CHARACTER MARK. INT. CL. 16. REG. 12-14-2004.
- 2,911,204. DRAGONFLY STANDARD CHARACTER MARK. INT. CL. 12. REG. 12-14-2004.
- 2,911,209. SEAFOOD HARVEST STANDARD CHARACTER MARK. INT. CL. 29. REG. 12-14-2004.
- 2,911,210. SHRIMP SHAKERS STANDARD CHARACTER MARK. INT. CL. 29. REG. 12-14-2004.
- 2,911,215. MISCELLANEOUS DESIGN. INT. CL. 29. REG. 12-14-2004.
- 2,911,221. EYES WIDE OPEN STANDARD CHARACTER MARK. INT. CL. 5. REG. 12-14-2004.
- 2,911,227. PILGRIM STANDARD CHARACTER MARK. INT. CL. 12. REG. 12-14-2004.
- 2,911,228. BANGOR & AROOSTOOK STANDARD CHARACTER MARK. INT. CL. 28. REG. 12-14-2004.
- 2,911,229. B&M STANDARD CHARACTER MARK. INT. CL. 28. REG. 12-14-2004.
- 2,911,231. BALI STANDARD CHARACTER MARK. INT. CL. 11. REG. 12-14-2004.
- 2,911,232. NT STANDARD CHARACTER MARK. INT. CL. 11. REG. 12-14-2004.
- 2,911,234. RUGSMART STANDARD CHARACTER MARK. INT. CL. 35. REG. 12-14-2004.
- 2,911,236. YOUR FIGHT IS OUR FIGHT STANDARD CHARACTER MARK. INT. CL. 42. REG. 12-14-2004.
- 2,911,237. THE START OF A GREAT PIZZA STANDARD CHARACTER MARK. INT. CL. 7. REG. 12-14-2004.
- 2,911,238. FLORISTBOARD STANDARD CHARACTER MARK. INT. CL. 42. REG. 12-14-2004.
- 2,911,240. MURILLO AND DESIGN. INT. CL. 30. REG. 12-14-2004.
- 2,911,241. COMMUNICATE YOUR LIFE STANDARD CHARACTER MARK. INT. CL. 35. REG. 12-14-2004.
- 2,911,243. REDEFINE DESIGN STANDARD CHARACTER MARK. INT. CL. 42. REG. 12-14-2004.
- 2,911,246. ALLIGATOR RAYS STANDARD CHARACTER MARK. INT. CL. 43. REG. 12-14-2004.
- 2,911,247. THE HONEYMOON TOOLKIT STANDARD CHARACTER MARK. INT. CL. 45. REG. 12-14-2004.
- 2,911,248. TAPESTREE TABLE STANDARD CHARACTER MARK. INT. CL. 20. REG. 12-14-2004.
- 2,911,249. ARTISTIC BEGINNINGS STANDARD CHARACTER MARK. INT. CL. 20. REG. 12-14-2004.
- 2,911,250. INSIDE MAYO CLINIC STANDARD CHARACTER MARK. INT. CL. 16. REG. 12-14-2004.
- 2,911,252. THE LAUNCHPAD FOR NEW IDEAS STANDARD CHARACTER MARK. INT. CL. 42. REG. 12-14-2004.
- 2,911,254. INVENT-TECH STANDARD CHARACTER MARK. INT. CL. 42. REG. 12-14-2004.
- 2,911,255. FIBROMICYN STANDARD CHARACTER MARK. INT. CL. 5. REG. 12-14-2004.
- 2,911,259. MASTERRESOURCES STANDARD CHARACTER MARK. INT. CL. 41. REG. 12-14-2004.
- 2,911,261. THE TRAVELIN' TRAINER STANDARD CHARACTER MARK. INT. CL. 9. REG. 12-14-2004.
- 2,911,264. BLUE KANGAROO STANDARD CHARACTER MARK. INT. CL. 21. REG. 12-14-2004.
- 2,911,268. STYLE & SUBSTANCE AND DESIGN. INT. CL. 16. REG. 12-14-2004.
- 2,911,269. STILE BY DESIGN STANDARD CHARACTER MARK. INT. CL. 40. REG. 12-14-2004.
- 2,911,270. FOREVERGLAZE STANDARD CHARACTER MARK. INT. CL. 40. REG. 12-14-2004.
- 2,911,271. JALB STANDARD CHARACTER MARK. INT. CL. 36. REG. 12-14-2004.
- 2,911,275. DOLLAR LANE STANDARD CHARACTER MARK. INT. CL. 35. REG. 12-14-2004.
- 2,911,276. SLEEPY MOON STANDARD CHARACTER MARK. INT. CL. 3. REG. 12-14-2004.

- 2,911,277. PURRFECT POST STANDARD CHARACTER MARK. INT. CL. 18. REG. 12-14-2004.
- 2,911,280. C.A.M.P. COMPLETE ATHLETES MADE POSSIBLE AND DESIGN. INT. CL. 41. REG. 12-14-2004.
- 2,911,281. TRIFOCUS STANDARD CHARACTER MARK. INT. CL. 9. REG. 12-14-2004.
- 2,911,283. BLUELIGHT STANDARD CHARACTER MARK. INT. CL. 41. REG. 12-14-2004.
- 2,911,285. BEANSTRO STANDARD CHARACTER MARK. INT. CL. 40. REG. 12-14-2004.
- 2,911,286. BFACT STANDARD CHARACTER MARK. INT. CL. 35. REG. 12-14-2004.
- 2,911,289. FRIENDLY PEOPLE FOR TODAY'S BANKING STANDARD CHARACTER MARK. INT. CL. 36. REG. 12-14-2004.
- 2,911,290. P PREMIERE GENERAL AND ELECTRICAL CONTRACTORS AND DESIGN. INT. CL. 37. REG. 12-14-2004.
- 2,911,293. BERRYCLEAR STANDARD CHARACTER MARK. INT. CL. 32. REG. 12-14-2004.
- 2,911,297. JAGGED ICE STANDARD CHARACTER MARK. INT. CL. 32. REG. 12-14-2004.
- 2,911,300. A SHOT AT THE CABO WABO STANDARD CHARACTER MARK. INT. CL. 25. REG. 12-14-2004.
- 2,911,303. IRONMAN AND DESIGN. INT. CL. 25. REG. 12-14-2004.
- 2,911,306. LOCARITA STANDARD CHARACTER MARK. INT. CL. 33. REG. 12-14-2004.
- 2,911,309. Z MEX GRILLE. INT. CL. 43. REG. 12-14-2004.
- 2,911,315. THE RIGHT ADVISOR. INT. CL. 35. REG. 12-14-2004.
- 2,911,316. CANADIAN C. INT. CL. 14. REG. 12-14-2004.
- 2,911,317. IPLANET. INT. CL. 42. REG. 12-14-2004.
- 2,911,318. CREMARETTO. INT. CL. 33. REG. 12-14-2004.
- 2,911,319. DON'T THINK TWICE. INT. CL. 25. REG. 12-14-2004.
- 2,911,320. INTEL NETSTRUCTURE. INT. CL. 9. REG. 12-14-2004.
- 2,911,324. RICHTREE INC. AND DESIGN. INT. CLS. 35 AND 42. REG. 12-14-2004.
- 2,911,329. BIOTRAC. INT. CL. 10. REG. 12-14-2004.
- 2,911,330. G FIRST (STYLIZED). INT. CL. 25. REG. 12-14-2004.
- 2,911,333. ANGEL SECURE NETWORKS. INT. CL. 9. REG. 12-14-2004.
- 2,911,334. IT-CURL. INT. CL. 26. REG. 12-14-2004.
- 2,911,336. V VINCENT MOTORCYCLES BLACKEAGLE AND DESIGN. INT. CL. 12. REG. 12-14-2004.
- 2,911,337. ZOOM. INT. CLS. 9 AND 28. REG. 12-14-2004.
- 2,911,340. SMART INFINITY. INT. CL. 28. REG. 12-14-2004.
- 2,911,342. BUFFMASTER. INT. CL. 10. REG. 12-14-2004.
- 2,911,344. B BEAULIEU HOME FASHIONS AND DESIGN. INT. CL. 27. REG. 12-14-2004.
- 2,911,345. MARIO TRICOCI HAIR SALONS AND DAY SPAS. INT. CL. 3. REG. 12-14-2004.
- 2,911,346. OBJECTMETHOD HEMISPHERE. INT. CL. 9. REG. 12-14-2004.
- 2,911,350. MISCELLANEOUS DESIGN. INT. CL. 35. REG. 12-14-2004.
- 2,911,351. DISPENSESOURCE. INT. CL. 35. REG. 12-14-2004.
- 2,911,352. X CONCEPTS. INT. CL. 9. REG. 12-14-2004.
- 2,911,358. W B B. INT. CL. 25. REG. 12-14-2004.
- 2,911,363. BUFFSPA. INT. CL. 3. REG. 12-14-2004.
- 2,911,364. CAPITON. INT. CL. 36. REG. 12-14-2004.
- 2,911,365. SOFTPAC. INT. CL. 39. REG. 12-14-2004.
- 2,911,366. GXPHERMA. INT. CL. 9. REG. 12-14-2004.
- 2,911,367. BUDDY'S BREAKFAST CLASSICS. INT. CL. 29. REG. 12-14-2004.
- 2,911,369. POURQUOI PAS. INT. CL. 3. REG. 12-14-2004.
- 2,911,370. AGRIFARGE. INT. CL. 19. REG. 12-14-2004.
- 2,911,374. CAPE CLEAR. INT. CL. 9. REG. 12-14-2004.
- 2,911,375. LAMBDA X. INT. CL. 9. REG. 12-14-2004.
- 2,911,376. CHROMUX TECHNOLOGIES INC. INT. CL. 9. REG. 12-14-2004.
- 2,911,378. DPAC TECHNOLOGIES AND DESIGN. INT. CL. 9. REG. 12-14-2004.
- 2,911,381. NERVE. INT. CL. 28. REG. 12-14-2004.
- 2,911,382. MISCELLANEOUS DESIGN. INT. CL. 42. REG. 12-14-2004.
- 2,911,385. SWIFT AND DESIGN. INT. CLS. 9, 16, 35, 36, 37, 38, 41 AND 42. REG. 12-14-2004.
- 2,911,387. MEDI-LOG STANDARD CHARACTER MARK. INT. CL. 16. REG. 12-14-2004.
- 2,911,389. BEST PUBLICATIONS AND DESIGN. INT. CL. 16. REG. 12-14-2004.
- 2,911,392. MICKEY'S PHILHARMAGIC. INT. CL. 28. REG. 12-14-2004.
- 2,911,394. OPTIUM DBM. INT. CL. 5. REG. 12-14-2004.
- 2,911,396. GRANGE PARK CAPITAL MANAGEMENT. INT. CL. 36. REG. 12-14-2004.
- 2,911,397. CITADON CW. INT. CL. 9. REG. 12-14-2004.
- 2,911,398. SANTA FE CORN FRIES. INT. CL. 29. REG. 12-14-2004.
- 2,911,400. ACOLOGIX. INT. CL. 5. REG. 12-14-2004.
- 2,911,403. P AND DESIGN. INT. CLS. 37 AND 42. REG. 12-14-2004.
- 2,911,405. SIGSCREEN. INT. CL. 42. REG. 12-14-2004.
- 2,911,406. MAGMA. INT. CL. 33. REG. 12-14-2004.
- 2,911,407. EQUIGUARDIAN. INT. CL. 5. REG. 12-14-2004.
- 2,911,408. AMPLIFRIES. INT. CL. 30. REG. 12-14-2004.
- 2,911,409. LITTLE BYTES AND FRIENDS. INT. CL. 41. REG. 12-14-2004.
- 2,911,417. IAC INTERNATIONAL AND DESIGN. INT. CL. 12. REG. 12-14-2004.
- 2,911,419. ARROWHEAD GLOBAL SOLUTIONS. INT. CLS. 37, 38 AND 42. REG. 12-14-2004.
- 2,911,420. FRESHENIZER. INT. CL. 1. REG. 12-14-2004.
- 2,911,422. STORM SHIELD AND DESIGN. INT. CL. 6. REG. 12-14-2004.
- 2,911,423. MANYONE. INT. CL. 42. REG. 12-14-2004.
- 2,911,424. ONEPOINT ALLIANCE. INT. CL. 36. REG. 12-14-2004.
- 2,911,425. COOKWELL AND DESIGN. INT. CL. 21. REG. 12-14-2004.
- 2,911,429. CELLINSURE AND DESIGN. INT. CL. 36. REG. 12-14-2004.
- 2,911,430. SICILIAN SUNSET AND DESIGN. INT. CLS. 29 AND 30. REG. 12-14-2004.
- 2,911,431. CLASSIC CAFE. INT. CL. 21. REG. 12-14-2004.
- 2,911,436. CARDIODATAPAD. INT. CL. 10. REG. 12-14-2004.
- 2,911,442. DR. DUCK. INT. CL. 32. REG. 12-14-2004.
- 2,911,443. STOCK ROOM BALER BY MARATHON EQUIPMENT AND DESIGN. INT. CL. 7. REG. 12-14-2004.
- 2,911,446. GINGY. INT. CL. 28. REG. 12-14-2004.
- 2,911,451. METAOR MEMBER IMC GROUP AND DESIGN. INT. CL. 40. REG. 12-14-2004.
- 2,911,452. ELYSIUM CAPITAL GROUP. INT. CL. 36. REG. 12-14-2004.
- 2,911,453. ELYSIUM CAPITAL. INT. CL. 36. REG. 12-14-2004.
- 2,911,455. FIRST WESTERN TRUST BANK. INT. CL. 36. REG. 12-14-2004.
- 2,911,456. COX COMMUNICATIONS DIGITAL CABLE DIGITAL TELEPHONE HIGH SPEED INTERNET A PREFERRED DIGITAL COMMUNITY AND DESIGN. INT. CL. 38. REG. 12-14-2004.
- 2,911,458. C IT SUCCEED. INT. CL. 36. REG. 12-14-2004.
- 2,911,459. OXYTROL OXYBUTYNIN TRANSDERMAL SYSTEM AND DESIGN. INT. CL. 5. REG. 12-14-2004.
- 2,911,460. MISCELLANEOUS DESIGN. INT. CL. 10. REG. 12-14-2004.
- 2,911,461. LIPOFADE. INT. CL. 3. REG. 12-14-2004.
- 2,911,462. APOLLO LIGHT. INT. CL. 10. REG. 12-14-2004.
- 2,911,463. BRITE WAVE. INT. CL. 10. REG. 12-14-2004.
- 2,911,464. MC FIELD CONDUCTOR. INT. CL. 9. REG. 12-14-2004.
- 2,911,468. ANCHOR CHURCH RESOURCES. INT. CL. 16. REG. 12-14-2004.
- 2,911,470. TARGETIR. INT. CL. 9. REG. 12-14-2004.
- 2,911,474. THE SPIN STOPS HERE. INT. CL. 25. REG. 12-14-2004.
- 2,911,477. BLUE ATTITUDE. INT. CL. 25. REG. 12-14-2004.

- 2,911,481. NOETTA. INT. CL. 41. REG. 12-14-2004.
 2,911,482. CONAD (STYLIZED). INT. CL. 9. REG. 12-14-2004.
 2,911,483. GOOD TECH. INT. CL. 25. REG. 12-14-2004.
 2,911,485. ONE CALL COVERS ALL. INT. CL. 37. REG. 12-14-2004.
 2,911,486. BACK ON THE BALL 1-800-321-BALL WWW.321BALL.COM AND DESIGN. INT. CL. 10. REG. 12-14-2004.
 2,911,487. CHIROVETPRACTIC. INT. CL. 44. REG. 12-14-2004.
 2,911,488. UBIQUICHAT. INT. CL. 9. REG. 12-14-2004.
 2,911,491. "SKEETER TREATER". INT. CL. 37. REG. 12-14-2004.
 2,911,492. EMBO (STYLIZED). INT. CL. 9. REG. 12-14-2004.
 2,911,495. HAUTE POTS. INT. CL. 21. REG. 12-14-2004.
 2,911,496. PRIZE DEPOT. INT. CL. 28. REG. 12-14-2004.
 2,911,497. BRESNAN ONLINE AND DESIGN. INT. CL. 38. REG. 12-14-2004.
 2,911,503. QUIKSERV. INT. CL. 16. REG. 12-14-2004.
 2,911,505. CANDI DELITE. INT. CLS. 29 AND 30. REG. 12-14-2004.
 2,911,510. COCODRIE PRESS AND DESIGN. INT. CL. 16. REG. 12-14-2004.
 2,911,514. QUICKWATER FOR SILKS. INT. CL. 1. REG. 12-14-2004.
 2,911,515. TEMPFIT. INT. CL. 20. REG. 12-14-2004.
 2,911,517. BOND BUILDING SYSTEMS, INC. AND DESIGN. INT. CL. 6. REG. 12-14-2004.
 2,911,520. NEW HOOD CITY. INT. CL. 41. REG. 12-14-2004.
 2,911,521. SABONIN AND DESIGN. INT. CL. 5. REG. 12-14-2004.
 2,911,522. MOLTEN MOTION WAX LITE (STYLIZED). INT. CL. 11. REG. 12-14-2004.
 2,911,523. MOLTEN MOTION WAX LITE. INT. CL. 11. REG. 12-14-2004.
 2,911,524. PROLIANCE MORTGAGE. INT. CL. 36. REG. 12-14-2004.
 2,911,525. HOMELAND. INT. CL. 4. REG. 12-14-2004.
 2,911,526. HEATILATOR HOME PRODUCTS AND DESIGN. INT. CL. 11. REG. 12-14-2004.
 2,911,527. ZOLON. INT. CL. 43. REG. 12-14-2004.
 2,911,528. CITY TRAILERS. INT. CL. 12. REG. 12-14-2004.
 2,911,530. MARISOL FEDERAL CREDIT UNION. INT. CL. 36. REG. 12-14-2004.
 2,911,531. MISCELLANEOUS DESIGN. INT. CL. 42. REG. 12-14-2004.
 2,911,532. YOUNG CHAMPIONS. INT. CL. 42. REG. 12-14-2004.
 2,911,533. GREAT SOUTH CATERING SERVING UP THE SOUTH BY FOLKS AND DESIGN. INT. CL. 43. REG. 12-14-2004.
 2,911,537. NUVU HEALTH. INT. CL. 35. REG. 12-14-2004.
 2,911,538. ECO COLLECTION. INT. CLS. 20 AND 24. REG. 12-14-2004.
 2,911,543. CAMP BUSINESS: THE LEARNING JOURNEY. INT. CL. 41. REG. 12-14-2004.
 2,911,544. FRUTZZO (STYLIZED). INT. CL. 32. REG. 12-14-2004.
 2,911,545. WHITESEAL TECHNOLOGY. INT. CL. 7. REG. 12-14-2004.
 2,911,549. COAST BREWING COMPANY BEAU RIVAGE BOCK. INT. CL. 32. REG. 12-14-2004.
 2,911,551. LEOPARD WATCHES & FINE JEWELLERY (STYLIZED). INT. CL. 14. REG. 12-14-2004.
 2,911,552. STUFF THIS. INT. CL. 31. REG. 12-14-2004.
 2,911,555. SENTINEL SOLUTIONS INCORPORATED. INT. CL. 44. REG. 12-14-2004.
 2,911,556. PORTAL. INT. CL. 14. REG. 12-14-2004.
 2,911,557. TUMMY BUDDIES. INT. CL. 5. REG. 12-14-2004.
 2,911,558. MOUNTAINWATCH. INT. CL. 9. REG. 12-14-2004.
 2,911,559. SONAR. INT. CL. 28. REG. 12-14-2004.
 2,911,564. TATT-MAN. INT. CL. 16. REG. 12-14-2004.
 2,911,565. ZAP. INT. CL. 28. REG. 12-14-2004.
 2,911,566. TOTAL DEFENSE. INT. CL. 5. REG. 12-14-2004.
 2,911,571. EXHALE (STYLIZED). INT. CL. 34. REG. 12-14-2004.
 2,911,574. SPORTSTREET (STYLIZED). INT. CLS. 36 AND 41. REG. 12-14-2004.
 2,911,575. MARIO TRICOCI HAIR SALONS AND DAY SPAS. INT. CL. 42. REG. 12-14-2004.
 2,911,577. HEDGESTREET. INT. CLS. 16 AND 36. REG. 12-14-2004.
 2,911,583. NATIONAL BROADWAY THEATRE AWARDS AND DESIGN. INT. CL. 41. REG. 12-14-2004.
 2,911,585. ART OF LONG DRIVING. INT. CL. 41. REG. 12-14-2004.
 2,911,587. N-TEK ENFORCER. INT. CL. 28. REG. 12-14-2004.
 2,911,588. ADVOCACY ANIMATION. INT. CL. 35. REG. 12-14-2004.
 2,911,589. TOP SHELF ANTIQUES. INT. CL. 21. REG. 12-14-2004.
 2,911,590. DRIVING IDEAS TO MARKET...AT THE SPEED OF INNOVATION. INT. CLS. 35, 39, 40 AND 42. REG. 12-14-2004.
 2,911,593. ARTMUSE RECORDS AND DESIGN. INT. CL. 9. REG. 12-14-2004.
 2,911,595. JIM "THE ROOKIE" MORRIS. INT. CL. 41. REG. 12-14-2004.
 2,911,596. NEMO AND DESIGN. INT. CL. 22. REG. 12-14-2004.
 2,911,597. MED-IC. INT. CL. 9. REG. 12-14-2004.
 2,911,598. GLOBALTRACS. INT. CL. 9. REG. 12-14-2004.
 2,911,600. THE WILDLIFE EXPERIENCE AND DESIGN. INT. CL. 16. REG. 12-14-2004.
 2,911,601. METROGUARD. INT. CL. 9. REG. 12-14-2004.
 2,911,604. KNOWING MORE. INT. CLS. 16 AND 44. REG. 12-14-2004.
 2,911,606. MUMSY. INT. CL. 16. REG. 12-14-2004.
 2,911,607. GE FOUNDATION. INT. CL. 36. REG. 12-14-2004.
 2,911,610. SINCERELY YOURS, KAREN. INT. CL. 14. REG. 12-14-2004.
 2,911,611. BALLBOYBROS AND DESIGN. INT. CLS. 25 AND 28. REG. 12-14-2004.
 2,911,612. PAINTER READY. INT. CL. 37. REG. 12-14-2004.
 2,911,615. CAMPUS ADVANTAGE. INT. CL. 38. REG. 12-14-2004.
 2,911,620. DINOSAURUS TEX AND DESIGN. INT. CL. 41. REG. 12-14-2004.
 2,911,621. SOUTHEND INTERACTIVE AND DESIGN. INT. CL. 9. REG. 12-14-2004.
 2,911,624. TEMPOSTATIN. INT. CL. 5. REG. 12-14-2004.
 2,911,628. CLEARLY COMMUNITY. INT. CL. 35. REG. 12-14-2004.
 2,911,630. WHISPER FOAM. INT. CL. 20. REG. 12-14-2004.
 2,911,631. MISCELLANEOUS DESIGN. INT. CLS. 41 AND 42. REG. 12-14-2004.
 2,911,633. MISCELLANEOUS DESIGN. INT. CL. 9. REG. 12-14-2004.
 2,911,634. THE PLATFORM. INT. CL. 16. REG. 12-14-2004.
 2,911,636. MINI IN SIZE. HUGE IN TASTE.. INT. CL. 30. REG. 12-14-2004.
 2,911,641. EL POPO. INT. CL. 32. REG. 12-14-2004.
 2,911,642. CLARKEAMERICAN.COM. INT. CLS. 16, 35, 40 AND 45. REG. 12-14-2004.
 2,911,645. REPUBLIC OF BOULDER. INT. CLS. 25 AND 43. REG. 12-14-2004.
 2,911,649. FLIPIT. INT. CL. 14. REG. 12-14-2004.
 2,911,650. FVCS. INT. CL. 9. REG. 12-14-2004.
 2,911,651. AT&T ULTRAVARIABLE MANAGED OPTERING SERVICE. INT. CL. 38. REG. 12-14-2004.
 2,911,652. BUSTBUDDIES. INT. CL. 10. REG. 12-14-2004.
 2,911,655. RJ'S ORIGINAL. INT. CL. 29. REG. 12-14-2004.
 2,911,656. THE WESTERN INSTITUTE FOR CORPORATE GOVERNANCE AND DESIGN. INT. CL. 41. REG. 12-14-2004.
 2,911,657. BABI-KINI. INT. CL. 25. REG. 12-14-2004.
 2,911,666. NHRA SPORT COMPACT EXTREME RUSH. INT. CL. 41. REG. 12-14-2004.
 2,911,667. TOTAL COAT AND DESIGN. INT. CL. 1. REG. 12-14-2004.
 2,911,669. MORE THAN ERA PROFESSIONAL PITCHING STATISTICS AND DESIGN. INT. CL. 9. REG. 12-14-2004.
 2,911,670. PLAY ON WORDS. INT. CL. 28. REG. 12-14-2004.
 2,911,671. SOY MAS FUERTE QUE LA DIABETES. INT. CL. 16. REG. 12-14-2004.

- 2,911,672. ROCCO FORTE HOTELS. INT. CLS. 36, 39, 41 AND 43. REG. 12-14-2004.
- 2,911,673. G-FORCE. INT. CL. 16. REG. 12-14-2004.
- 2,911,674. MOLECULARDIAMOND TECHNOLOGIES. INT. CL. 1. REG. 12-14-2004.
- 2,911,675. MOLECULARDIAMOND. INT. CL. 1. REG. 12-14-2004.
- 2,911,680. "WHAT A CONCEPT!". INT. CLS. 4, 9, 20 AND 21. REG. 12-14-2004.
- 2,911,684. B3BASICS. INT. CL. 21. REG. 12-14-2004.
- 2,911,687. HOTEL COLLECTION BY CHARTER CLUB. INT. CL. 24. REG. 12-14-2004.
- 2,911,688. CBP. INT. CLS. 35 AND 42. REG. 12-14-2004.
- 2,911,689. MYCBP. INT. CLS. 35 AND 42. REG. 12-14-2004.
- 2,911,690. GLOBAL COMPANY/LOCAL SOLUTIONS. INT. CL. 40. REG. 12-14-2004.
- 2,911,691. TRADITIONS BY BERNARDI A TASTE OF AUTHENTIC ITALY. INT. CL. 30. REG. 12-14-2004.
- 2,911,697. OIL RITE "THE FIRST TIME". INT. CLS. 7 AND 9. REG. 12-14-2004.
- 2,911,702. SCION. INT. CL. 28. REG. 12-14-2004.
- 2,911,703. IGNITE YOUR SENSES. INT. CL. 41. REG. 12-14-2004.
- 2,911,705. STEEL APOCALYPSE COLLECTION. INT. CL. 8. REG. 12-14-2004.
- 2,911,706. THE OFFICIAL VEHICLE OF INDEPENDENCE DAY. INT. CL. 35. REG. 12-14-2004.
- 2,911,707. THE OFFICIAL VEHICLE OF THE FOURTH OF JULY. INT. CL. 35. REG. 12-14-2004.
- 2,911,708. SQ. INT. CLS. 7 AND 12. REG. 12-14-2004.
- 2,911,711. ZIXWORKS. INT. CL. 38. REG. 12-14-2004.
- 2,911,713. YOSOY. INT. CL. 4. REG. 12-14-2004.
- 2,911,714. TEACHERS' SUCCESS. INT. CLS. 16 AND 41. REG. 12-14-2004.
- 2,911,715. THE LINK TO TEACHERS' SUCCESS.... INT. CLS. 16 AND 41. REG. 12-14-2004.
- 2,911,716. MRET. INT. CL. 9. REG. 12-14-2004.
- 2,911,719. LEMON GROVE. INT. CL. 3. REG. 12-14-2004.
- 2,911,721. ONE GLOBAL FINANCE. INT. CL. 36. REG. 12-14-2004.
- 2,911,725. CLEAR LIGHTING FOUNDATION. INT. CL. 3. REG. 12-14-2004.
- 2,911,726. ZING. INT. CL. 31. REG. 12-14-2004.
- 2,911,728. FOOT FOCUS. INT. CLS. 10 AND 35. REG. 12-14-2004.
- 2,911,730. SECURECHOICE AND DESIGN. INT. CL. 44. REG. 12-14-2004.
- 2,911,731. SPRING LILIES. INT. CL. 3. REG. 12-14-2004.
- 2,911,732. LIFE IN THE 2ND HALF. INT. CL. 41. REG. 12-14-2004.
- 2,911,736. LIFE. DIVIDED BY VACATIONS. INT. CL. 36. REG. 12-14-2004.
- 2,911,738. SECOND SUITCASE. INT. CL. 18. REG. 12-14-2004.
- 2,911,743. PRO SELECT. INT. CLS. 3 AND 5. REG. 12-14-2004.
- 2,911,744. AWESOME KIDS. INT. CL. 25. REG. 12-14-2004.
- 2,911,745. AWESOME BOYS. INT. CL. 25. REG. 12-14-2004.
- 2,911,746. AWESOME BABY. INT. CL. 14. REG. 12-14-2004.
- 2,911,747. AWESOME FAMILY. INT. CL. 14. REG. 12-14-2004.
- 2,911,748. AWESOME BABY. INT. CL. 3. REG. 12-14-2004.
- 2,911,750. EZ-GATE. INT. CL. 12. REG. 12-14-2004.
- 2,911,751. AWESOME BABY. INT. CL. 9. REG. 12-14-2004.
- 2,911,752. AWESOME BABY. INT. CL. 41. REG. 12-14-2004.
- 2,911,753. AWESOME BABY. INT. CL. 28. REG. 12-14-2004.
- 2,911,754. AWESOME FAMILY. INT. CL. 9. REG. 12-14-2004.
- 2,911,756. THE VILLAGE OF AWESOME. INT. CL. 14. REG. 12-14-2004.
- 2,911,758. AND JUST LIKE THAT, IT BEGINS. INT. CL. 3. REG. 12-14-2004.
- 2,911,759. CIRCUIT-SAFETY. INT. CL. 6. REG. 12-14-2004.
- 2,911,760. BUMPERCUTS. INT. CL. 44. REG. 12-14-2004.
- 2,911,762. AWESOME STYLE. INT. CL. 25. REG. 12-14-2004.
- 2,911,763. AWESOME STYLE. INT. CL. 41. REG. 12-14-2004.
- 2,911,764. WINEHEAD. INT. CL. 35. REG. 12-14-2004.
- 2,911,765. AWESOME STYLE. INT. CL. 6. REG. 12-14-2004.
- 2,911,766. AWESOME STYLE. INT. CL. 18. REG. 12-14-2004.
- 2,911,767. AWESOME STYLE. INT. CL. 24. REG. 12-14-2004.
- 2,911,768. COALITION FORCES. INT. CL. 28. REG. 12-14-2004.
- 2,911,770. STONEGROUND. INT. CLS. 9 AND 41. REG. 12-14-2004.
- 2,911,773. FAMILY AWESOME. INT. CL. 14. REG. 12-14-2004.
- 2,911,774. FAMILY AWESOME. INT. CL. 25. REG. 12-14-2004.
- 2,911,775. FAMILY AWESOME. INT. CL. 41. REG. 12-14-2004.
- 2,911,776. AMERICAN REFLECTIONS A CONTINUATION OF THE HERITAGE OF THE FAMILY AWESOME. INT. CL. 28. REG. 12-14-2004.
- 2,911,778. CALM THAT FRIZZ!. INT. CL. 3. REG. 12-14-2004.
- 2,911,780. GOPHONE. INT. CL. 9. REG. 12-14-2004.
- 2,911,781. INTEGRA-TOUCH. INT. CL. 9. REG. 12-14-2004.
- 2,911,782. CREATIVE THOUGHT MATTERS. INT. CL. 41. REG. 12-14-2004.
- 2,911,783. CREATIVE THOUGHT MATTERS. INT. CL. 16. REG. 12-14-2004.
- 2,911,784. MIGHTY OATS. INT. CLS. 30 AND 31. REG. 12-14-2004.
- 2,911,786. GRIP 'N WRITE. INT. CL. 16. REG. 12-14-2004.
- 2,911,789. FLEXIUM. INT. CL. 6. REG. 12-14-2004.
- 2,911,790. GAME CAGE. INT. CL. 41. REG. 12-14-2004.
- 2,911,791. MISCELLANEOUS DESIGN. INT. CL. 25. REG. 12-14-2004.
- 2,911,792. ADJUVANT. INT. CL. 35. REG. 12-14-2004.
- 2,911,793. RAPID ORGANIZATIONAL IMPACT. INT. CL. 41. REG. 12-14-2004.
- 2,911,794. YOUR PRESCRIPTION FOR CREATIVITY. INT. CL. 35. REG. 12-14-2004.
- 2,911,798. ADVANCED MAGNETIC SOLUTIONS. INT. CLS. 35 AND 42. REG. 12-14-2004.
- 2,911,799. BIJOU. INT. CLS. 16 AND 20. REG. 12-14-2004.
- 2,911,800. TOTAL BULL. INT. CL. 41. REG. 12-14-2004.
- 2,911,801. MEDDETECT. INT. CL. 45. REG. 12-14-2004.
- 2,911,803. AUTOHEROES. INT. CL. 35. REG. 12-14-2004.
- 2,911,808. ASPARA AROMATICS. INT. CL. 3. REG. 12-14-2004.
- 2,911,809. DURA CREASE TECHNOLOGY. INT. CL. 25. REG. 12-14-2004.
- 2,911,810. TOTAL 802.11. INT. CL. 9. REG. 12-14-2004.
- 2,911,813. MAXMART. INT. CL. 35. REG. 12-14-2004.
- 2,911,815. BECAUSE THE WORLD IS GETTING SMALLER. INT. CLS. 16 AND 41. REG. 12-14-2004.
- 2,911,816. GIVING THE EARTH A BREAK. INT. CL. 5. REG. 12-14-2004.
- 2,911,817. PAINT FAUCET AND DESIGN. INT. CL. 35. REG. 12-14-2004.
- 2,911,820. SILICONCITY. INT. CL. 9. REG. 12-14-2004.
- 2,911,824. ENERGIZER. INT. CL. 9. REG. 12-14-2004.
- 2,911,825. SAPIAS. INT. CL. 42. REG. 12-14-2004.
- 2,929,134. BREAK THE SILENCE. INT. CL. 25 ONLY. REG. 3-1-2005.
- 2,941,616. SUNMARK. INT. CL. 21 ONLY. REG. 4-19-2005.
- 2,954,102. ARIZONA. INT. CL. 5 ONLY. REG. 5-24-2005.
- 2,954,240. MITUS. INT. CL. 9 ONLY. REG. 5-24-2005.
- 2,954,526. ENGINEERED WITH PRIDE STANDARD CHARACTER MARK. INT. CL. 1 ONLY. REG. 5-24-2005.
- 2,956,022. COBS. INT. CLS. 35 AND 43 ONLY. REG. 5-24-2005.
- 2,956,023. COBS BREAD. INT. CLS. 35 AND 43 ONLY. REG. 5-24-2005.
- 2,957,786. BEAZER AND DESIGN. INT. CL. 36 ONLY. REG. 5-31-2005.
- 2,959,217. WHO YOU INVEST WITH IS EVERYTHING STANDARD CHARACTER MARK. INT. CL. 37 ONLY. REG. 6-7-2005.
- 2,959,310. THERMOMAX. INT. CL. 7 ONLY. REG. 6-7-2005.
- 2,962,008. MISCELLANEOUS DESIGN. INT. CLS. 6 AND 9 ONLY. REG. 6-14-2005.
- 2,964,515. IMSPECT (STYLIZED). INT. CLS. 37 AND 42 ONLY. REG. 7-5-2005.
- 2,965,400. VESPA. INT. CL. 3 ONLY. REG. 7-12-2005.

- 2,967,740. TANITA MONITORING YOUR HEALTH AND DESIGN. INT. CL. 44 ONLY. REG. 7-12-2005.
- 2,969,734. LOFLI. INT. CL. 26 ONLY. REG. 7-19-2005.
- 2,976,681. SENSIA. INT. CL. 21 ONLY. REG. 7-26-2005.
- 2,977,251. I STILL WANT TO BE A CPA. INT. CL. 16 ONLY. REG. 7-26-2005.
- 2,977,340. I STILL WANT TO BE A FARMER. INT. CL. 16 ONLY. REG. 7-26-2005.
- 2,977,391. I STILL WANT TO BE A BANKER. INT. CL. 16 ONLY. REG. 7-26-2005.
- 2,977,404. I STILL WANT TO BE A NURSE. INT. CL. 16 ONLY. REG. 7-26-2005.
- 2,983,193. DIGITAL ID WORLD STANDARD CHARACTER MARK. INT. CLS. 16 AND 42 ONLY. REG. 8-9-2005.
- 2,985,522. PENNY VILLE STANDARD CHARACTER MARK. INT. CL. 41 ONLY. REG. 8-16-2005.
- 2,987,136. SERVICE PRO AND DESIGN. INT. CLS. 7 AND 21 ONLY. REG. 8-23-2005.
- 3,007,224. PAW BROTHERS. INT. CLS. 10, 18 AND 20 ONLY. REG. 10-18-2005.
- 3,012,934. COLONIAL WILLIAMSBURG HISTORIC TRADES CWHT AND DESIGN. INT. CL. 8 ONLY. REG. 11-8-2005.
- 3,023,420. OC AND DESIGN. INT. CL. 41 ONLY. REG. 12-6-2005.
- 3,025,726. SMITH'S SINCE 1886 AND DESIGN. INT. CL. 9 ONLY. REG. 12-13-2005.
- 3,068,593. LITTLE DIVERSIFIED ARCHITECTURAL CONSULTING (STYLIZED). INT. CL. 42 ONLY. REG. 3-14-2006.
- 3,070,074. SENILIFE AND DESIGN. INT. CL. 31 ONLY. REG. 3-21-2006.

SECTION 18

- 400,434. TRU ADE NOT CARBONATED AND DESIGN. U.S. CL. 45. REG. 3-9-1943.
- 1,253,994. CHIPWICH. INT. CL. 42. REG. 10-11-1983.
- 2,130,804. GIANNI VALENTINO. INT. CL. 18. REG. 1-20-1998.
- 2,494,936. RM AND DESIGN. INT. CL. 36. REG. 10-2-2001.
- 2,881,888. KUZ STANDARD CHARACTER MARK. INT. CL. 3. REG. 9-7-2004.
- 3,032,478. PAY SQUARE AND DESIGN. INT. CLS. 9 AND 36. REG. 12-20-2005.

- 3,051,016. PAYSQUARE STANDARD CHARACTER MARK. INT. CL. 36. REG. 1-24-2006.
- 3,130,908. PANTA STANDARD CHARACTER MARK. INT. CL. 9. REG. 8-15-2006.
- 3,149,732. SCENTRIC STANDARD CHARACTER MARK. INT. CL. 9. REG. 9-26-2006.
- 3,160,179. PANTA (STYLIZED). INT. CL. 9. REG. 10-17-2006.
- 3,176,043. CALAVERA STANDARD CHARACTER MARK. INT. CL. 25. REG. 11-28-2006.
- 3,259,015. POWER ONE AND DESIGN. INT. CL. 3. REG. 7-3-2007.
- 3,291,259. POWER ONE AND DESIGN. INT. CL. 4. REG. 9-11-2007.
- 3,585,915. GENEUS STANDARD CHARACTER MARK. INT. CL. 9. REG. 3-10-2009.
- 3,896,646. SIBELLA STANDARD CHARACTER MARK. INT. CLS. 3, 14 AND 25. REG. 12-28-2010.

SECTION 71

- 2,964,316. POUPELLE STANDARD CHARACTER MARK. INT. CL. 3. REG. 6-28-2005.
- 2,967,266. F A. JONES (STYLIZED). INT. CLS. 14 AND 16 ONLY. REG. 7-12-2005.
- 2,976,306. FRAMAR AND DESIGN. INT. CLS. 6, 20 AND 28 ONLY. REG. 7-26-2005.
- 2,998,484. PASTOLINE STANDARD CHARACTER MARK. INT. CLS. 7, 9 AND 37 ONLY. REG. 9-20-2005.
- 3,023,879. ARÉZOO STANDARD CHARACTER MARK. INT. CLS. 3 AND 44 ONLY. REG. 12-6-2005.
- 3,035,983. HEIDI CHEESE LINE AND DESIGN. INT. CLS. 8 AND 11 ONLY. REG. 12-27-2005.
- 3,079,834. PREGEL AND DESIGN. INT. CL. 31. REG. 4-11-2006.

INADVERTENTLY ISSUED REGISTRATION NUMBERS

- 3,783,211. GIANT AND DESIGN. INT. CL. 41. REG. 5-4-2010. RESTORED TO SN 77-415,664.
- 3,871,854. USS AND DESIGN. INT. CL. 35. REG. 11-9-2010. RESTORED TO SN 77-406,740.

* * * * *

TRADEMARK REGISTRATIONS AMENDED, CORRECTED, ETC.

The designation "U.S. Cl." appearing in this section refers to the U.S. class in effect prior to Sep. 1, 1973 rather than the international class which applies to applications filed on or after that date. For adoption of international classification see notice in the OFFICIAL GAZETTE of Jun. 26, 1973 (911 O.G. TM 210).

Any change to the registration will be indicated at the bottom of each entry under ELEMENTS AMENDED, CORRECTED OR RESTRICTED. With the exception of changes to the goods and services, additions to the registration will appear in asterisks and deletions of the registration will appear in brackets. Elements which are only changed will be listed with no punctuation. As to the goods/services statement, amendments to the goods/services will appear in asterisks and deletions will appear in brackets. In addition if any change to the goods/services occurs, the element "Goods/Services" will be listed under ELEMENTS AMENDED, CORRECTED OR RESTRICTED.

1,743,759. REG. 12-29-1992. JEWISH COUNCIL FOR THE AGING OF GREATER WASHINGTON, INC. (MARYLAND NOT-FOR-PROFIT CORPORATION) 12320 PARKLAWN DRIVE, ROCKVILLE, MD, 20852, SN 74-249,226. FILED 2-24-1992. PRINCIPAL REGISTER.

2,195,330. REG. 10-13-1998. CHAMPION WINDOW MANUFACTURING AND SUPPLY CO., LLC (DELAWARE LIMITED LIABILITY COMPANY) 12121 CHAMPION WAY, CINCINNATI, OH, 45241, SN 75-322,053. FILED 7-10-1997. PRINCIPAL REGISTER.

INTERAGES

INT. CL. 42/U.S. CL. 100

FOR COMMUNITY SERVICES; NAMELY, ORGANIZING AND COORDINATING PROJECTS BY AND BETWEEN YOUTHS AND SENIOR ADULTS FOR THEIR MUTUAL BENEFIT, SUCH AS VISITING OF NURSING HOMES, WORKSHOPS, SEMINARS, DISCUSSIONS AND JOINT COMMUNITY SERVICES.

FIRST USE 1-1-1987; IN COMMERCE 1-1-1987.

ELEMENTS CORRECTED
OWNER NAME

2,075,835. REG. 7-1-1997. TARGET BRANDS, INC. (MINNESOTA CORPORATION) 1000 NICOLLET MALL, MINNEAPOLIS, MN, 55403, SN 75-158,375. FILED 8-30-1996. PRINCIPAL REGISTER.

PROSPIRIT

THE MARK CONSISTS OF STANDARD CHARACTERS WITHOUT CLAIM TO ANY PARTICULAR FONT, STYLE, SIZE, OR COLOR.

OWNER OF U.S. REG. NOS. 1,340,989 AND 1,354,374.

INT. CL. 25/U.S. CLS. 22 AND 39

FOR MEN'S, WOMEN'S AND CHILDREN'S APPAREL, NAMELY, PANTS, SHORTS, [SWIMWEAR, LEGGINGS,] TOPS, SWEATSHIRTS, SOCKS, FOOTWEAR, BRAS [LEOTARDS] AND JACKETS.

FIRST USE 7-0-1988; IN COMMERCE 7-0-1988.

ELEMENTS AMENDED
ASSIGNMENT/NAME CHANGE
MARK

Champion

INT. CL. 19/U.S. CLS. 1, 12, 33 AND 50

FOR NON-METAL NEW AND REPLACEMENT WINDOWS, PATIO AND SLIDING DOORS AND WINDOW SCREENS.

FIRST USE 12-0-1979; IN COMMERCE 12-0-1979.

INT. CL. 37/U.S. CLS. 100, 103 AND 106

FOR INSTALLATION OF REPLACEMENT WINDOWS, WINDOW SCREENS, STORM WINDOWS AND SIDING AND CONSTRUCTION OF SUN PORCHES, ENCLOSED PATIOS, AND ROOM ADDITIONS FOR OTHERS.

FIRST USE 12-0-1979; IN COMMERCE 12-0-1979.

ELEMENTS AMENDED
MARK

2,418,016. REG. 1-2-2001. INTELLIGENT BIOCIDES, LLC (DELAWARE LIMITED LIABILITY COMPANY) 37 BEVERLEE ROAD, TYNGSBOROUGH, MA, 01879, SN 75-514,405. FILED 7-7-1998. PRINCIPAL REGISTER.

INTELLIGENT BIOCIDES

NO CLAIM IS MADE TO THE EXCLUSIVE RIGHT TO USE "BIOCIDES", APART FROM THE MARK AS SHOWN.

INT. CL. 1/U.S. CLS. 1

FOR ANTIMICROBIAL AND DISINFECTING CHEMICALS USED IN THE MANUFACTURE OF CLEANING PRODUCTS, DISINFECTION PRODUCTS, SANITATION PRODUCTS, PERSONAL HEALTHCARE, HYGIENE AND BEAUTY CARE PRODUCTS.

FIRST USE 12-7-1998; IN COMMERCE 12-7-1998.

ELEMENTS CORRECTED
ENTITY

2,429,777. REG. 2-20-2001. DAVE ANDERSON CORPORATION, THE (CALIFORNIA CORPORATION) PO BOX 2338, AGOURA HILLS, CA, 91376, SN 75-906,908. FILED 1-22-2000. PRINCIPAL REGISTER.

2,531,648. REG. 1-22-2002. DREAMLAND HOLDING COMPANY, LLC (DELAWARE LIMITED LIABILITY COMPANY) 1427 14TH AVENUE SOUTH, BIRMINGHAM, AL, 35205, SN 76-103,083. FILED 8-7-2000. PRINCIPAL REGISTER.

Learn to Lead

INT. CL. 16/U.S. CLS. 2, 5, 22, 23, 29, 37, 38 AND 50
FOR NEWSLETTERS FEATURING INFORMATION ON LEADERSHIP SKILLS.
FIRST USE 5-1-1999; IN COMMERCE 5-1-1999.

ELEMENTS CORRECTED
OWNER NAME



2,458,728. REG. 6-5-2001. AVOCENT HUNTSVILLE CORP. (ALABAMA CORPORATION) 4991 CORPORATE DRIVE, HUNTSVILLE, AL, 35805, SN 75-549,298. FILED P.R. 9-8-1998; AM. S.R. 9-15-2000. SUPPLEMENTAL REGISTER.

NO CLAIM IS MADE TO THE EXCLUSIVE RIGHT TO USE "BAR B QUE RIBS", APART FROM THE MARK AS SHOWN.

INT. CL. 42/U.S. CLS. 100 AND 101
FOR RESTAURANT SERVICES.
FIRST USE 5-24-1989; IN COMMERCE 5-24-1989.

AUTOTUNING

INT. CL. 9/U.S. CLS. 21, 23, 26, 36 AND 38
FOR * EMBEDDED SOFTWARE COMPONENT OF * COMPUTER PERIPHERALS, NAMELY, EQUIPMENT FOR LINKING A PERSONAL COMPUTER TO A REMOTE KEYBOARD, MONITOR, AND MOUSE AND INCLUDING CIRCUITRY COMPENSATING FOR SYSTEM DIFFERENCES.
FIRST USE 7-1-1998; IN COMMERCE 7-1-1998.

ELEMENTS AMENDED
GOODS/SERVICES

ELEMENTS CORRECTED
ENTITY

2,535,324. REG. 2-5-2002. VOYAGER ESTATE [WA] PTY LTD (AUSTRALIA CORPORATION) 105 FORREST STREET, COTTESLOE, WESTERN AUSTRALIA, 6011, AUSTRALIA., SN 75-741,307. FILED 6-22-1999. PRINCIPAL REGISTER.

2,482,405. REG. 8-28-2001. PGA TOUR, INC. (MARYLAND CORPORATION) 112 PGA TOUR BOULEVARD, PONTE VEDRA BEACH, FL, 32082, SN 76-126,849. FILED 9-12-2000. PRINCIPAL REGISTER.

LEGENDS OF GOLF

THE MARK CONSISTS OF STANDARD CHARACTERS WITHOUT CLAIM TO ANY PARTICULAR FONT, STYLE, SIZE, OR COLOR.

OWNER OF U.S. REG. NO. 1,158,439.
NO CLAIM IS MADE TO THE EXCLUSIVE RIGHT TO USE "GOLF", APART FROM THE MARK AS SHOWN.

INT. CL. 41/U.S. CLS. 100, 101 AND 107
FOR SERVICES IN CONNECTION WITH CONDUCTING A PROFESSIONAL GOLF TOURNAMENT.
FIRST USE 4-26-1978; IN COMMERCE 4-26-1978.

ELEMENTS AMENDED
MARK



PRIORITY CLAIMED UNDER SEC. 44(D) ON AUSTRALIA APPLICATION NO. 782178, FILED 12-23-1998, REG. NO. 782178, DATED 12-23-1998.

INT. CL. 14/U.S. CLS. 2, 27, 28 AND 50
FOR [JEWELRY; TRINKETS, NAMELY BROOCHES, CHARMS, TIE-CLIPS, HAT ORNAMENTS OF PRECIOUS METAL, AND NECKLACES; HOROLOGICAL AND CHRONOMETRIC INSTRUMENTS, NAMELY WATCHES, STOP WATCHES, SUN DIALS, AND CLOCKS].

FIRST USE ; IN COMMERCE .
INT. CL. 16/U.S. CLS. 2, 5, 22, 23, 29, 37, 38 AND 50

FOR PAPER AND GOODS MADE FROM PAPER MATERIALS, NAMELY NOTE PAPER, NOTEBOOK PAPER, ONION SKIN PAPER, RECYCLED PAPER, PARCHMENT PAPER, REPRODUCTION PAPER, COMPUTER PAPER, COPY PAPER, LINING PAPER, WRITING PAPER, PAPER NAME BADGES, PAPER BAGS FOR PACKAGING, PAPER BANNERS, WRAPPING PAPER, PAPER GIFT WRAP, PAPER GIFT WRAP BOWS, PAPER CAKE DECORATIONS, DECORATIVE PAPER CENTERPIECES, PAPER TABLE CLOTHS, PAPER TABLE LINEN, PAPER HATS, PAPER NAPKINS, PAPER PENNANTS, PAPER PLACE MATS, PAPER TRAY COVERS, PAPER TRAYS, PAPER DRAWER LINERS, COASTERS MADE OF PAPER, PAPER CONTAINERS, CRAFT PAPER, PAPER PARTY DECORATIONS, PAPER DOILIES, PAPER MACHE FIGURINES, PAPER FILE JACKETS, PAPER FLAGS, PAPER HANDKERCHIEFS, AND PAPER PICTURE MOUNTS; CARDBOARD AND GOODS MADE FROM CARD-BOARD MATERIALS, NAMELY CARD-BOARD BOXES, CARDBOARD CONTAINERS, CARDBOARD FLOOR DISPLAY UNITS FOR MERCHANDISING PRODUCTS, CARDBOARD PICTURE MOUNTS, AND CARDBOARD MAILING TUBES, STATIONERY; PRINTED MATTER, NAMELY PRINTED GUIDES FOR WINE, BUSINESS AND COMMERCIAL MANAGEMENT, MANAGEMENT AND ADMINISTRATION OF WINERY OPERATIONS, INVESTMENT MANAGEMENT, MANAGEMENT AND ADMINISTRATION OF WINERY OPERATIONS, REAL ESTATE MANAGEMENT, MANAGEMENT AND ADMINISTRATION OF RURAL PROPERTIES, AND MANAGEMENT AND ADMINISTRATION OF COMMERCIAL PROPERTIES; PRINTED TEACHING MATERIALS ON THE SUBJECT OF WINE, BUSINESS AND COMMERCIAL MANAGEMENT, MANAGEMENT AND ADMINISTRATION OF WINERY OPERATIONS, INVESTMENT MANAGEMENT, MANAGEMENT AND ADMINISTRATION OF WINERY OPERATIONS, REAL ESTATE MANAGEMENT, MANAGEMENT AND ADMINISTRATION OF RURAL PROPERTIES, AND MANAGEMENT AND ADMINISTRATION OF COMMERCIAL PROPERTIES; PERIODICALS, NAMELY GENERAL FEATURE MAGAZINES, WINE MAGAZINES, BUSINESS AND COMMERCIAL MANAGEMENT MAGAZINES, MANAGEMENT AND ADMINISTRATION OF WINERY OPERATIONS MAGAZINES, INVESTMENT MANAGEMENT MAGAZINES, MANAGEMENT AND ADMINISTRATION OF WINERY OPERATIONS MAGAZINES, REAL ESTATE MANAGEMENT MAGAZINES, MANAGEMENT AND ADMINISTRATION OF RURAL PROPERTIES MAGAZINES, AND MANAGEMENT AND ADMINISTRATION OF COMMERCIAL PROPERTIES MAGAZINES.

FIRST USE ; IN COMMERCE .

INT. CL. 21/U.S. CLS. 2, 13, 23, 29, 30, 33, 40 AND 50
FOR GLASSWARE, NAMELY BEVERAGE GLASSWARE.

FIRST USE ; IN COMMERCE .

INT. CL. 25/U.S. CLS. 22 AND 39
FOR [CLOTHING, NAMELY SHIRTS, PANTS, SUITS, SWEATERS, JACKETS, AND UNDERGARMENTS; AND HEADWEAR].

FIRST USE ; IN COMMERCE .

INT. CL. 30/U.S. CL. 46
FOR [COFFEE AND TEA].

FIRST USE ; IN COMMERCE .

INT. CL. 32/U.S. CLS. 45, 46 AND 48
FOR [NON-ALCOHOLIC DRINKS, NAMELY NON-ALCOHOLIC BEER, NON-ALCOHOLIC MALT COOLERS, NON-ALCOHOLIC PUNCHES, MINERAL WATER, DISTILLED WATER, PURIFIED WATER, CARBONATED WATER, FRUIT JUICES, FRUIT DRINKS, ISOTONIC DRINKS, AND SOFT DRINKS].

FIRST USE ; IN COMMERCE .

INT. CL. 33/U.S. CLS. 47 AND 49

FOR [ALCOHOLIC BEVERAGES, NAMELY, BITTERS, PUNCH, PREPARED COCKTAILS, COFFEE-BASED BEVERAGES, APERITIFS WITH A WINE BASE, DISTILLED LIQUOR, DISTILLED SPIRITS, SPIRITS MADE FROM FRUIT LIQUEURS, PREPARED ALCOHOLIC COCKTAILS, WINE PUNCH APERITIFS WITH A DISTILLED ALCOHOLIC LIQUOR BASE, AND ALCOHOLIC PUNCH; WINE, NAMELY, RED WINE, WHITE WINE, BLUSH WINE, COOKING WINE, FRUIT WINE ALCOHOLIC BEVERAGES, NAMELY, WINE PUNCH, WINES, NAMELY, RED WINE, WHITE WINE, BLUSH WINE, COOKING WINE, FRUIT WINE] * ALCOHOLIC BEVERAGES, NAMELY, WINES, NAMELY, RED WINE, WHITE WINE, BLUSH WINE, COOKING WINE, FRUIT WINE *.

FIRST USE ; IN COMMERCE .
INT. CL. 35/U.S. CLS. 100, 101 AND 102

FOR [BUSINESS MANAGEMENT SERVICES, NAMELY BUSINESS MANAGEMENT AND ORGANIZATION CONSULTATION, COMMERCIAL MANAGEMENT ASSISTANCE, MANAGEMENT AND ADMINISTRATION OF A WINERY OPERATION].

FIRST USE ; IN COMMERCE .

ELEMENTS AMENDED
GOODS/SERVICES

2,587,070. REG. 7-2-2002. HOLOFIBER ENTERPRISES, INC. (CALIFORNIA CORPORATION) 1112 MONTANA AVE., STE 13, SANTA MONTANA, CA, 90403, SN 75-662,029. FILED 3-17-1999. PRINCIPAL REGISTER.

HOLOFIBER

INT. CL. 25/U.S. CLS. 22 AND 39
FOR CLOTHING NAMELY, HATS, T-SHIRTS, TANK TOPS, JACKETS, PANTS, JEANS, SWEATSHIRTS, SWEATPANTS, BANDANNAS, SHORTS, UNDERWEAR, JERSEYS, AND SHIRTS.

FIRST USE 11-15-1998; IN COMMERCE 1-1-1999.

ELEMENTS CORRECTED
OWNER NAME
OWNER ADDRESS

2,629,393. REG. 10-1-2002. MAZE, STEPHANIE (UNITED STATES INDIVIDUAL) 7820 ORACLE PLACE, POTOMAC, MD, 20854, SN 78-035,586. FILED 11-16-2000. PRINCIPAL REGISTER.

MOONSTONE PRESS

NO CLAIM IS MADE TO THE EXCLUSIVE RIGHT TO USE "PRESS", APART FROM THE MARK AS SHOWN.

INT. CL. 16/U.S. CLS. 2, 5, 22, 23, 29, 37, 38 AND 50
FOR PRINTED MATTER, NAMELY, CHILDREN'S BOOKS; BOOK COVERS; BOOKMARKS; NEWSLETTERS, PAMPHLETS AND BROCHURES ABOUT CHILDREN'S BOOKS; PHOTO-ILLUSTRATED, NON-FICTION, PRINTED INSTRUCTIONAL, EDUCATIONAL AND TEACHING MATERIALS FOR CHILDREN FOR USE AT THE PRE-K TO 12 GRADE LEVELS;] AND POSTERS; GREETING CARDS; PAPER ENVELOPES FOR PACKAGING; AND FOLDERS].

FIRST USE 9-1-2001; IN COMMERCE 12-1-2001.

ELEMENTS AMENDED
GOODS/SERVICES

2,654,278. REG. 11-26-2002. CARDIOCOM, LLC (MINNESOTA LIMITED LIABILITY COMPANY) 7980 CENTURY BLVD., CHANHASSEN, MN, 55317, SN 76-364,801. FILED 1-29-2002. PRINCIPAL REGISTER.

CARDIOPLAN

INT. CL. 44/U.S. CLS. 100 AND 101
 FOR HOME HEALTH CARE SERVICES IN THE NATURE OF INTERACTIVE MEDICAL CARE MONITORING FOR PATIENTS.
 FIRST USE 7-0-2001; IN COMMERCE 7-0-2001.

ELEMENTS CORRECTED
 ENTITY

2,816,784. REG. 2-24-2004. UNITED STEEL PRODUCTS COMPANY, INC. (MINNESOTA CORPORATION) 14305 SOUTHCROSS DRIVE, SUITE 200, BURNSVILLE, MN, 55306, SN 76-506,438. FILED 4-14-2003. PRINCIPAL REGISTER.

USP CONNECTION

INT. CL. 9/U.S. CLS. 21, 23, 26, 36 AND 38
 FOR COMPUTER SOFTWARE IN THE FIELD OF BUILDING CONSTRUCTION FOR AUTOMATED STRUCTURAL CONNECTOR SELECTION.
 FIRST USE 7-0-1997; IN COMMERCE 7-0-1997.

ELEMENTS CORRECTED
 OWNER NAME

2,891,646. REG. 10-5-2004. WAKE FOREST UNIVERSITY (NORTH CAROLINA CORPORATION) 1834 WAKE FOREST ROAD, SCHOOL OF MEDICINE, WINSTON-SALEM, NC, 27157, SN 76-429,499. FILED 7-8-2002. PRINCIPAL REGISTER.

WAKE FOREST UNIVERSITY HEALTH SCIENCES

OWNER OF U.S. REG. NOS. 1,249,260, 2,319,350 AND OTHERS.
 NO CLAIM IS MADE TO THE EXCLUSIVE RIGHT TO USE "UNIVERSITY HEALTH SCIENCES", APART FROM THE MARK AS SHOWN.
 INT. CL. 41/U.S. CLS. 100, 101 AND 107
 FOR EDUCATIONAL SERVICES, NAMELY, CONDUCTING CLASSES, SEMINARS, CONFERENCES, AND WORKSHOPS IN THE FIELD OF MEDICINE, AND DISTRIBUTION OF MATERIALS IN CONNECTION THEREWITH.
 FIRST USE 7-1-2002; IN COMMERCE 7-1-2002.

ELEMENTS CORRECTED
 ENTITY

2,929,329. REG. 3-1-2005. UNITED STEEL PRODUCTS COMPANY, INC. (MINNESOTA CORPORATION) 14305 SOUTHCROSS DRIVE, SUITE 200, BURNSVILLE, MN, 55306, SN 76-483,041. FILED 1-14-2003. PRINCIPAL REGISTER.

USP STRUCTURAL CONNECTORS

NO CLAIM IS MADE TO THE EXCLUSIVE RIGHT TO USE STRUCTURAL CONNECTORS, APART FROM THE MARK AS SHOWN.
 INT. CL. 6/U.S. CLS. 2, 12, 13, 14, 23, 25 AND 50
 FOR METAL CONNECTORS, PLATES AND BRACKETS FOR STRUCTURAL FRAMING; [METAL SAWHORSE BRACKETS;] METAL FRAMING AND JUNCTION PLATES USED IN THE CONSTRUCTION OF GEODESIC AND OTHER BUILDINGS.
 FIRST USE 12-31-2002; IN COMMERCE 12-31-2002.
 INT. CL. 9/U.S. CLS. 21, 23, 26, 36 AND 38
 FOR COMPUTER SOFTWARE FOR THE DESIGN OF BUILDINGS UTILIZING METAL PLATES, BRACKETS AND CONNECTORS IN THEIR CONSTRUCTION.
 FIRST USE 2-28-2003; IN COMMERCE 2-28-2003.

ELEMENTS CORRECTED
 OWNER NAME

2,953,042. REG. 5-17-2005. CARDINAL HEALTH TECHNOLOGIES, LLC (NEVADA LIMITED LIABILITY COMPANY) 7690 CHEYENNE AVENUE, SUITE 100, LAS VEGAS, NV, 89129, SN 78-157,260. FILED 8-23-2002. PRINCIPAL REGISTER.



OWNER OF U.S. REG. NOS. 2,249,206, 2,255,186 AND 2,308,398.
 INT. CL. 35/U.S. CLS. 100, 101 AND 102
 FOR DISTRIBUTORSHIP SERVICES TO HOSPITALS, CLINICS AND OTHER HEALTH PRODUCT RETAILERS IN THE PHARMACEUTICAL, RADIOPHARMACEUTICAL, HEALTH CARE PRODUCTS, MEDICAL PRODUCTS AND SURGICAL PRODUCTS FIELDS; BUSINESS MANAGEMENT SUPPORT AND CONSULTING SERVICES FOR HOSPITALS, CLINICS, ALTERNATE CARE CENTERS; PROMOTIONAL SUPPORT PROGRAMS, STORE LAYOUT ASSISTANCE, COUPON REDEMPTION, AND PROCUREMENT, NAMELY, EQUIPMENT SPECIFICATION AND PURCHASING; COMPUTERIZED DATABASE MANAGEMENT OF HEALTH CARE PLANS; PACKAGING PHARMACEUTICAL AND HEALTH CARE PRODUCTS TO THE ORDER AND SPECIFICATION OF OTHERS; [PACKAGING ARTICLES TO THE ORDER AND SPECIFICATION OF OTHERS, NAMELY, PACKAGING LIQUID PHARMACEUTICALS FOR PHARMACEUTICAL MANUFACTURES;] ELECTRONIC CUSTOMER ORDERING SERVICES FOR MEDICAL, SURGICAL, LABORATORY SUPPLIES AND EQUIPMENT; ELECTRONIC CUSTOMER ORDERING SERVICES FOR PHARMACEUTICALS, MEDICAL, SURGICAL AND LABORATORY SUPPLIES AND EQUIPMENT; ON-LINE PRODUCT CATALOG FEATURING A FULL LINE OF PHARMACEUTICALS, MEDICAL, SURGICAL AND LABORATORY SUPPLIES AND EQUIPMENT; INVENTORY CONTROL OF HOSPITAL EQUIPMENT; INVENTORY CONTROL OF HOSPITAL LINENS; MEDICATION MANAGEMENT SERVICES, NAMELY, ASSESS TOTAL MEDICATION USE, COSTS AND PRIORITIZE SPECIFIC OPPORTUNITIES FOR OVERALL COST-REDUCTION;

MANAGEMENT AND OPERATION OF HEALTH CARE FACILITIES FOR OTHERS; COMPUTERIZED PHARMACEUTICAL RECORD KEEPING AND PHARMACEUTICAL INVENTORY SERVICES, NAMELY, LICENSING COMPUTER SOFTWARE PHARMACEUTICAL RECORD KEEPING AND PHARMACEUTICAL INVENTORY PROGRAMS; ADVERTISING SERVICES, NAMELY, ADVERTISING AGENCIES; PROVIDING ADVERTISING SPACE IN A PERIODICAL; CREATING CORPORATE LOGOS FOR OTHERS; CREATING CORPORATE, BRAND, AND PRODUCT IDENTITY FOR OTHERS; ADVERTISING SLOGAN AND CARTOON CHARACTER LICENSING; AGENCIES FOR ADVERTISING TIME AND SPACE; COOPERATIVE ADVERTISING AND MARKETING; DIRECT MARKETING ADVERTISING FOR OTHERS; DISPLAYING ADVERTISEMENTS FOR OTHERS; DISSEMINATION OF ADVERTISING FOR OTHERS VIA THE INTERNET; DISSEMINATION OF ADVERTISING MATTER; ELECTRONIC BILLBOARD ADVERTISING; PREPARING AND PLACING OF ADVERTISING FOR OTHERS VIA A GLOBAL COMPUTER NETWORK; OUTSOURCING MARKETING SERVICES FOR OTHERS IN THE PHARMACEUTICAL FIELD.

FIRST USE 1-1-2003; IN COMMERCE 1-1-2003.
INT. CL. 42/U.S. CLS. 100 AND 101

FOR COMPUTER SYSTEM SUPPORT SERVICES FOR THIRD PARTIES IN THE HEALTH CARE PRODUCTS, MEDICAL PRODUCTS AND SURGICAL PRODUCTS FIELD, NAMELY LOADING AND UPDATING OF COMPUTER SOFTWARE AND DEPLOYMENT OF COMPUTER SYSTEMS TO FACILITATE PRODUCT ORDERING, INVENTORY MANAGEMENT, COST ACCOUNTING, PATIENT PROFILES, THIRD PARTY BILLING AND THE PRODUCTION OF MANAGEMENT REPORTS.

FIRST USE 1-1-2003; IN COMMERCE 1-1-2003.

ELEMENTS CORRECTED
OWNER NAME
ENTITY

2,953,043. REG. 5-17-2005. CARDINAL HEALTH TECHNOLOGIES, LLC (NEVADA LIMITED LIABILITY COMPANY) 7660 W CHEYENNE AVE, SUITE 113, LAS VEGAS, NV, 89129, SN 78-157,264. FILED 8-23-2002. PRINCIPAL REGISTER.



OWNER OF U.S. REG. NOS. 2,249,206, 2,308,398 AND OTHERS.

INT. CL. 25/U.S. CLS. 22 AND 39

FOR LAB COATS, FOOTWEAR, SOCKS, AND UNIFORMS FOR HEALTHCARE PROFESSIONALS; HEADWEAR.

FIRST USE 1-1-2003; IN COMMERCE 1-1-2003.

ELEMENTS CORRECTED
ENTITY

2,953,177. REG. 5-17-2005. CARDINAL HEALTH TECHNOLOGIES, LLC (NEVADA LIMITED LIABILITY COMPANY) 7660 W CHEYENNE AVE, SUITE 113, LAS VEGAS, NV, 89129, SN 78-194,914. FILED 12-16-2002. PRINCIPAL REGISTER.

CARDINAL HEALTH

OWNER OF U.S. REG. NOS. 2,249,206, 2,308,398 AND OTHERS.

NO CLAIM IS MADE TO THE EXCLUSIVE RIGHT TO USE "HEALTH", APART FROM THE MARK AS SHOWN.

INT. CL. 39/U.S. CLS. 100 AND 105

FOR PHARMACEUTICAL DRUG DELIVERY SERVICES.

FIRST USE 1-31-2003; IN COMMERCE 1-31-2003.

INT. CL. 42/U.S. CLS. 100 AND 101

FOR DRUG DEVELOPMENT SERVICES; CONSULTATION IN THE FIELD OF PHARMACEUTICAL DRUG DELIVERY TECHNOLOGIES; MANUFACTURE OF PHARMACEUTICALS AND VITAMINS TO THE ORDER AND/OR SPECIFICATION OF OTHERS; PRODUCT RESEARCH SERVICES, NAMELY, PROVIDING ANALYTICAL TESTING, REPORTING AND LABORATORY SERVICES FOR OTHERS; PHARMACEUTICAL TECHNICAL CONSULTING; PRODUCT DEVELOPMENT AND RESEARCH IN THE FIELD OF RADIOPHARMACEUTICALS; COMPUTER SERVICES, NAMELY, CONSULTING WITH DRUG STORES AND PHARMACIES ABOUT COMPUTER SYSTEMS; COMPUTER SERVICES, NAMELY, CREATING AND DESIGNING WEB SITES FOR OTHERS; PROVIDING WEB SITES OF OTHERS ON A COMPUTER SERVER FOR A GLOBAL COMPUTER NETWORK; COMPUTER WEB SITE MAINTENANCE FOR OTHERS; CONSULTING REGARDING DESIGN SERVICES OF COMPUTER HARDWARE AND SOFTWARE IN THE FIELDS OF GLOBAL COMPUTER DESIGN, GLOBAL COMPUTER MAINTENANCE, GLOBAL COMPUTER IMPLEMENTATION AND GLOBAL COMPUTER STORAGE AND DISSEMINATION OF DATA VIA COMPUTER NETWORKS, THE DESIGN AND DEVELOPMENT OF ELECTRONIC COMMERCE SYSTEMS OVER A GLOBAL COMPUTER NETWORK; GRAPHIC ART DESIGN, NAMELY, IMAGE DESIGN AND GENERATION.

FIRST USE 1-16-1995; IN COMMERCE 1-16-1995.

INT. CL. 44/U.S. CLS. 100 AND 101

FOR MEDICAL CONSULTING SERVICES, NAMELY, RECOMMENDING TO MEDICAL FACILITIES MEDICAL SUPPLIES AND PRODUCTS TO BE USED FOR SPECIFIC TYPES OF SURGERY.

FIRST USE 1-31-2004; IN COMMERCE 1-31-2004.

ELEMENTS CORRECTED
ENTITY

2,958,134. REG. 5-31-2005. POPP, EUGEN (FED REP GERMANY INDIVIDUAL) WIDENMAYERSTR. 48, MUNICH, FED REP GERMANY, 80538, AND SAJDA, WOLF E. (FED REP GERMANY INDIVIDUAL) WIDENMAYERSTR. 48, MUNICH, FED REP GERMANY, 80538, AND BOHNENBERGER, JOHANNES (FED REP GERMANY INDIVIDUAL) WIDENMAYERSTR. 48, MUNICH, FED REP GERMANY, 80538, AND KRUPIG, VOLKMAR (FED REP GERMANY INDIVIDUAL) WIDENMAYERSTR. 48, MUNICH, FED REP GERMANY, 80538, AND RUPPRECHT, KAY (FED REP GERMANY INDIVIDUAL) WIDENMAYERSTR. 48, MUNICH, FED REP GERMANY, 80538, AND ZECH, STEFAN M. (FED REP GERMANY INDIVIDUAL) WIDENMAYERSTR. 48, MUNICH, FED REP GERMANY, 80538, AND HEINZE, EKKEHARD (FED REP GERMANY INDIVIDUAL) WIDENMAYERSTR. 48, MUNICH, FED REP GERMANY, 80538, AND SCHROER, GERNOT H. (FED REP GERMANY INDIVIDUAL) WIDENMAYERSTR. 48, MUNICH, FED REP GERMANY, 80538, SN 78-253,773. FILED 5-23-2003. PRINCIPAL REGISTER.

FOR PROCESS CONTROL AND MANUFACTURING AUTOMATION DEVICES.
FIRST USE 6-0-1998; IN COMMERCE 6-0-1998.

ELEMENTS AMENDED
OWNER ADDRESS
CERTIFICATION STATEMENT

MBP

INT. CL. 41/U.S. CLS. 100, 101 AND 107
FOR [PROVIDING OF TRAINING OF LEGAL EDUCATION IN THE FIELD OF INTELLECTUAL PROPERTY, ORGANIZATION OF CONFERENCES, CONVENTIONS, SEMINARS AND SYMPOSIUMS IN THE FIELD OF INTELLECTUAL PROPERTY AND PUBLISHING OF BOOKS, MAGAZINES, AND NEWSPAPERS].

FIRST USE 9-23-2003; IN COMMERCE 9-23-2003.
INT. CL. 42/U.S. CLS. 100 AND 101
FOR LEGAL SERVICES OF THE LAW FIRM.
FIRST USE 2-3-2003; IN COMMERCE 2-3-2003.

ELEMENTS AMENDED
GOODS/SERVICES

2,975,086. REG. 7-26-2005. FIELDBUS FOUNDATION (MINNESOTA CORPORATION) BOWIE BLDG - SUITE 200, 9005 MOUNTAIN RIDGE DRIVE, AUSTIN, TX, 787595316, SN 76-444,116. FILED 8-27-2002. PRINCIPAL REGISTER.



OWNER OF U.S. REG. NO. 2,144,989.
NO CLAIM IS MADE TO THE EXCLUSIVE RIGHT TO USE FOUNDATION, APART FROM THE MARK AS SHOWN.
THE CERTIFICATION MARK, AS USED BY PERSONS AUTHORIZED BY THE CERTIFIER, CERTIFIES THAT THE GOODS PROVIDED, NAMELY, PRODUCTS USED IN INDUSTRIAL AUTOMATION, NAMELY, PROCESS CONTROL AND MANUFACTURING AUTOMATION FIELD DEVICES, HOST SYSTEMS AND SUPPORTING NETWORK COMPONENTS, HAVE PASSED ALL APPLICABLE TEST CASES IN THE CONFORMANCE TEST SYSTEM, THE INTEROPERABILITY TEST SYSTEM, AND THE PHYSICAL LAYER TEST SYSTEM.
INT. CL. A /U.S. CL. A

2,976,489. REG. 7-26-2005. CJ FOODVILLE CORP. (REPUBLIC OF KOREA CORPORATION) 8F, KOO SAN TOWER, 3250, BANGBAE-DONG, SEOCHO-KU, SEOUL, REPUBLIC OF KOREA., SN 76-072,204. FILED 6-16-2000. PRINCIPAL REGISTER.



NO CLAIM IS MADE TO THE EXCLUSIVE RIGHT TO USE "FRESH BAKERY" AND "FRESH EVERYDAY", APART FROM THE MARK AS SHOWN.
THE FRENCH PHRASE "TOUS LES JOURS" TRANSLATES TO ENGLISH AS "EVERY DAY".
INT. CL. 42/U.S. CLS. 100 AND 101
FOR RESTAURANT CHAINS; RESTAURANTS; CAFETERIAS; SNACK-BARS.
FIRST USE 4-30-2004; IN COMMERCE 4-30-2004.

ELEMENTS AMENDED
OWNER ADDRESS
MARK

2,990,979. REG. 9-6-2005. UNITED STEEL PRODUCTS COMPANY, INC. (MINNESOTA CORPORATION) 14305 SOUTHCROSS DRIVE, SUITE 200, BURNSVILLE, MN, 55306, SN 76-506,437. FILED 4-14-2003. PRINCIPAL REGISTER.

SEAT CLEAT

NO CLAIM IS MADE TO THE EXCLUSIVE RIGHT TO USE "CLEAT", APART FROM THE MARK AS SHOWN.
SEC. 2(F).
INT. CL. 6/U.S. CLS. 2, 12, 13, 14, 23, 25 AND 50
FOR METAL CONNECTORS FOR STRUCTURAL FRAMING.
FIRST USE 1-0-1996; IN COMMERCE 1-0-1996.

ELEMENTS CORRECTED
OWNER NAME

3,021,383. REG. 11-29-2005. HOLOFIBER ENTERPRISES, INC. (CALIFORNIA CORPORATION) SUITE 13, 1112 MONTANA AVE., SANTA MONICA, CA, 90403, SN 76-488,331. FILED 2-6-2003. PRINCIPAL REGISTER.



INT. CL. 22/U.S. CLS. 1, 2, 7, 19, 22, 42 AND 50
FOR POLYMERIC FIBERS AND STAPLE FIBERS.
FIRST USE 1-1-1999; IN COMMERCE 1-1-1999.

INT. CL. 23/U.S. CL. 43
FOR YARNS.

FIRST USE 1-1-1999; IN COMMERCE 1-1-1999.

INT. CL. 24/U.S. CLS. 42 AND 50

FOR FABRIC FOR USE IN THE MANUFACTURE OF CLOTHING, NAMELY, HOSIERY, ACTIVE WEAR, SPORTS WEAR, UNDERWEAR, SOCKS, GLOVES, HATS, SHOE INSERTS AND SHOE COVERINGS; FABRIC FOR USE IN THE MANUFACTURE OF FURNISHINGS, NAMELY, UPHOLSTERY, MATTRESSES, BLANKETS AND SHEETS; FABRIC FOR USE IN THE MANUFACTURE OF OUTDOOR FURNISHINGS, NAMELY, AWNINGS; AND FABRIC FOR USE IN THE MANUFACTURE OF SPORTS WRAPS AND BANDAGES.

FIRST USE 1-1-1999; IN COMMERCE 1-1-1999.

ELEMENTS CORRECTED
OWNER NAME

3,031,574. REG. 12-20-2005. LAFAYETTE BAND ASSOCIATION (KENTUCKY CORPORATION) P.O. BOX 910450, LEXINGTON, KY, 405910450, SN 78-412,156. FILED 5-3-2004. PRINCIPAL REGISTER.

Pride of the
Bluegrass

THE MARK CONSISTS OF STANDARD CHARACTERS WITHOUT CLAIM TO ANY PARTICULAR FONT, STYLE, SIZE, OR COLOR.

NO CLAIM IS MADE TO THE EXCLUSIVE RIGHT TO USE BLUEGRASS, APART FROM THE MARK AS SHOWN.
INT. CL. 41/U.S. CLS. 100, 101 AND 107

FOR ENTERTAINMENT IN THE NATURE OF HIGH SCHOOL BAND PERFORMANCES.

FIRST USE 1-1-1963; IN COMMERCE 1-1-1963.

ELEMENTS CORRECTED
OWNER NAME

3,041,194. REG. 1-10-2006. WBS HOCKEY LP (PENNSYLVANIA LIMITED PARTNERSHIP) 415 ARENA HUB, WILKES-BARRE, PA, 15317, SN 78-517,409. FILED 11-16-2004. PRINCIPAL REGISTER.



NO CLAIM IS MADE TO THE EXCLUSIVE RIGHT TO USE "WILKES-BARRE SCRANTON", APART FROM THE MARK AS SHOWN.

THE STIPPLING IS FOR SHADING PURPOSES ONLY.

THE MARK CONSISTS OF A STYLIZED WILKES-BARRE SCRANTON PENGUINS.

INT. CL. 25/U.S. CLS. 22 AND 39

FOR CLOTHING, NAMELY, INFANT, MEN'S, WOMEN'S AND CHILDREN'S SWEATSHIRTS, T-SHIRTS, JACKETS AND COATS, SWEATERS, SWEATPANTS, HEADWEAR, NIGHTSHIRTS, SHORTS, PANTS, JERSEYS, SLEEPWEAR, SHIRTS, FOOTWEAR, SOCKS, TIES AND CLOTH BIBS, * ALL OF THE FOREGOING TO COMMEMORATE A PROFESSIONAL HOCKEY TEAM*.

FIRST USE 1-0-1998; IN COMMERCE 1-0-1998.

INT. CL. 41/U.S. CLS. 100, 101 AND 107

FOR ENTERTAINMENT SERVICES IN THE NATURE OF PROFESSIONAL ICE HOCKEY EXHIBITIONS, GAMES, AND CONTESTS.

FIRST USE 1-0-1998; IN COMMERCE 1-0-1998.

ELEMENTS AMENDED
GOODS/SERVICES

3,044,932. REG. 1-17-2006. NAPO, INC. (TEXAS NON-PROFIT CORPORATION), NATIONAL ASSOCIATION OF PROFESSIONAL ORGANIZERS, INC., 15000 COMMERCE PARKWAY, SUITE C, MOUNT LAUREL, NJ, 08054, SN 78-428,009. FILED 6-1-2004. PRINCIPAL REGISTER.



NO CLAIM IS MADE TO THE EXCLUSIVE RIGHT TO USE "NATIONAL ASSOCIATION OF PROFESSIONAL ORGANIZERS", APART FROM THE MARK AS SHOWN.

NATIONAL ASSOCIATION OF PROFESSIONAL ORGANIZERS.

INT. CL. 35/U.S. CLS. 100, 101 AND 102

FOR ASSOCIATION SERVICES, NAMELY, PROMOTING THE INTERESTS OF PROFESSIONAL ORGANIZERS.

FIRST USE 7-0-2003; IN COMMERCE 7-0-2003.

ELEMENTS CORRECTED
DBA/AKA
OWNER NAME
OWNER ADDRESS

3,047,739. REG. 1-24-2006. BLUMENTHAL DISTRIBUTING, INC. (CALIFORNIA CORPORATION), DBA OFFICE STAR PRODUCTS, P.O. BOX 3520, ONTARIO, CA, 917612327. SN 76-597,608. FILED 6-16-2004. PRINCIPAL REGISTER.

AIR GRID

THE MARK CONSISTS OF STANDARD CHARACTERS WITHOUT CLAIM TO ANY PARTICULAR FONT, STYLE, SIZE, OR COLOR.

INT. CL. 24/U.S. CLS. 42 AND 50
FOR FABRIC FOR USE ON CHAIRS.
FIRST USE 3-9-2004; IN COMMERCE 4-10-2004.

ELEMENTS CORRECTED
DBA/AKA
OWNER NAME

3,055,878. REG. 1-31-2006. HOLOFIBER ENTERPRISES, INC. (CALIFORNIA CORPORATION) SUITE 13, 1112 MONTANA AVE., SANTA MONICA, CA, 90403, SN 76-488,397. FILED 2-10-2003. PRINCIPAL REGISTER.

HOLOFIBER

OWNER OF U.S. REG. NO. 2,587,070.
INT. CL. 10/U.S. CLS. 26, 39 AND 44
FOR WOUND HEALING, PROSTHETIC DEVICES, NAMELY, DIABETIC SOCKS AND OTHER POST AND PREVENTATIVE INJURY WRAPS AND DEVICES, NAMELY, SOCKS, GLOVES, ARCH SUPPORTS, HOSIERY, AND BANDAGE WRAPS; MEDICAL POST-SURGICAL SOCKS AND WRAPS.

FIRST USE 2-1-2003; IN COMMERCE 2-1-2003.
INT. CL. 24/U.S. CLS. 42 AND 50
FOR HOSPITAL BED PADS AND MATTRESS COVERS AND FILLING FOR GENERAL HOSPITAL USE.
FIRST USE 1-1-2004; IN COMMERCE 1-1-2004.

ELEMENTS CORRECTED
OWNER NAME

3,106,304. REG. 6-20-2006. GET A MOVE ON, INC. (KANSAS CORPORATION) 520 N. WASHINGTON, WICHITA, KS, 67214, SN 78-583,738. FILED 3-9-2005. PRINCIPAL REGISTER.



NO CLAIM IS MADE TO THE EXCLUSIVE RIGHT TO USE "MOVING", APART FROM THE MARK AS SHOWN.
INT. CL. 39/U.S. CLS. 100 AND 105

FOR MOVING VAN SERVICES, NAMELY, THE PROVISION OF TRUCKS AND LABOR FOR PACKING, LOADING, DELIVERY, AND UNLOADING OF GOODS.
FIRST USE 2-21-2003; IN COMMERCE 2-21-2003.

ELEMENTS CORRECTED
MARK

3,120,857. REG. 7-25-2006. NOKIA CORPORATION (FINLAND CORPORATION) KEILALAHDENTIE 4, FIN-02150 ESPOO, FINLAND., SN 79-006,554. FILED 8-5-2004. PRINCIPAL REGISTER.



PRIORITY DATE OF 2-6-2004 IS CLAIMED.
OWNER OF INTERNATIONAL REGISTRATION 0836729 DATED 8-5-2004, EXPIRES 8-5-2014.

INT. CL. 9/U.S. CLS. 21, 23, 26, 36 AND 38
FOR COMPUTER GAME SOFTWARE FOR COMMUNICATION DEVICES; COMPUTER GAME SOFTWARE AND PROGRAMS ENABLING USERS TO PLAY GAMES WITH MOBILE PHONES; COMPUTER SOFTWARE AND PROGRAMS ENABLING USERS OF COMMUNICATION DEVICES TO SIMULTANEOUSLY ACCESS DATABASES AND GLOBAL COMPUTER NETWORKS; COMPUTER SOFTWARE ENABLING TRANSFER OF DATA BETWEEN MOBILE COMMUNICATION APPARATUS; VIRTUAL REALITY GAME SOFTWARE; MOBILE TELEPHONES AND MOBILE TELEPHONES FEATURING SHORT MESSAGING, INTERNET ACCESS, MP3 PLAYER AND RADIO; PORTABLE LISTENING DEVICES, NAMELY, MP3 PLAYERS AND RADIOS; DOWN-LOADABLE COMPUTER GAME SOFTWARE.

ELEMENTS CORRECTED
MARK TYPE
[GOODS/SERVICES]
[INTERNATIONAL CLASS(ES)]

3,188,945. REG. 12-26-2006. CLK ASSOCIATES, LLC (OHIO LIMITED LIABILITY COMPANY) 35734 WYNDEMERE WAY, AVON, OH, 44011, SN 78-667,734. FILED 7-11-2005. PRINCIPAL REGISTER.

DEAR CONSUMER

THE MARK CONSISTS OF STANDARD CHARACTERS WITHOUT CLAIM TO ANY PARTICULAR FONT, STYLE, SIZE, OR COLOR.

NO CLAIM IS MADE TO THE EXCLUSIVE RIGHT TO USE "CONSUMER", APART FROM THE MARK AS SHOWN.

INT. CL. 45/U.S. CLS. 100 AND 101
FOR CONSUMER ADVOCACY SERVICES, NAMELY PLACING OF TELEPHONE CALLS AND LETTER AND E-MAIL WRITING TO BUSINESSES ON BEHALF OF DISSATISFIED CONSUMERS.

FIRST USE 1-17-2005; IN COMMERCE 3-14-2005.

ELEMENTS CORRECTED
OWNER NAME

3,189,963. REG. 12-26-2006. YUAN, LIPING (CHINA INDIVIDUAL) 1593 ESPRIT DR., WESTFIELD, IN, 46074, SN 78-523,386. FILED 11-28-2004. PRINCIPAL REGISTER.

3,246,006. REG. 5-29-2007. UNITED STEEL PRODUCTS COMPANY, INC. (MINNESOTA CORPORATION) SUITE 200, 14305 SOUTHCROSS DRIVE, BURNSVILLE, MN, 55306, SN 77-006,981. FILED 9-25-2006. PRINCIPAL REGISTER.

WESTFIELD OUTDOORS

THE MARK CONSISTS OF STANDARD CHARACTERS WITHOUT CLAIM TO ANY PARTICULAR FONT, STYLE, SIZE, OR COLOR.

NO CLAIM IS MADE TO THE EXCLUSIVE RIGHT TO USE "OUTDOOR", APART FROM THE MARK AS SHOWN. INT. CL. 20/U.S. CLS. 2, 13, 22, 25, 32 AND 50 FOR OUTDOOR FURNITURE. FIRST USE 1-0-2005; IN COMMERCE 1-0-2005.

ELEMENTS AMENDED
MARK



3,246,005. REG. 5-29-2007. UNITED STEEL PRODUCTS COMPANY, INC. (MINNESOTA CORPORATION) SUITE 200, 14305 SOUTHCROSS DRIVE, BURNSVILLE, MN, 55306, SN 77-006,973. FILED 9-25-2006. PRINCIPAL REGISTER.



THE MARK CONSISTS OF A PAIR OF MIRROR-IMAGE TRAPEZOIDS WITH ONE CHEVRON AT THE TOP AND ANOTHER CHEVRON AT THE BOTTOM OF THE TRAPEZOID PAIR.

INT. CL. 9/U.S. CLS. 21, 23, 26, 36 AND 38

FOR COMPUTER SOFTWARE FOR THE DESIGN OF BUILDINGS AND OTHER STRUCTURES UTILIZING METAL FASTENERS, CONNECTORS, PLATES, BRACKETS, NAILS AND SCREWS IN THEIR CONSTRUCTION; COMPUTER SOFTWARE IN THE FIELD OF BUILDING CONSTRUCTION FOR AUTOMATED STRUCTURAL CONNECTOR SELECTION.

FIRST USE 7-31-2005; IN COMMERCE 7-31-2005.

ELEMENTS CORRECTED
OWNER NAME



3,250,334. REG. 6-12-2007. UNITED STEEL PRODUCTS COMPANY, INC. (MINNESOTA CORPORATION) SUITE 200, 14305 SOUTHCROSS DRIVE, BURNSVILLE, MN, 55306, SN 77-006,976. FILED 9-25-2006. PRINCIPAL REGISTER.

THE MARK CONSISTS OF A PAIR OF MIRROR-IMAGE TRAPEZOIDS WITH ONE CHEVRON AT THE TOP AND ANOTHER CHEVRON AT THE BOTTOM OF THE TRAPEZOID PAIR.

INT. CL. 1/U.S. CLS. 1

FOR EPOXY ADHESIVES AND SYNTHETIC RESINS FOR REPAIRING AND BONDING BUILDING MATERIALS TO CONCRETE, MASONRY, WOOD AND STEEL.

FIRST USE 7-31-2005; IN COMMERCE 7-31-2005.

ELEMENTS CORRECTED
OWNER NAME

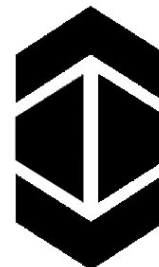

THE MARK CONSISTS OF A PAIR OF MIRROR-IMAGE TRAPEZOIDS WITH ONE CHEVRON AT THE TOP AND ANOTHER CHEVRON AT THE BOTTOM OF THE TRAPEZOID PAIR.

INT. CL. 6/U.S. CLS. 2, 12, 13, 14, 23, 25 AND 50

FOR METAL FASTENERS, CONNECTORS, ANCHORS, PLATES, BRACKETS, NAILS, AND SCREWS FOR STRUCTURAL FRAMING AND FASTENING BUILDING MATERIALS TO CONCRETE, MASONRY, WOOD AND STEEL; METAL BASES FOR FENCE POSTS, POST CAPS, AND FENCE BRACKETS.

FIRST USE 7-31-2005; IN COMMERCE 7-31-2005.

ELEMENTS CORRECTED
OWNER NAME

3,291,557. REG. 9-11-2007. LA DOLCE DIVA, INC. (GEORGIA CORPORATION) 2305 BRANDON COURT, MARIETTA, GA. 30066, SN 78-493,544. FILED 10-2-2004. PRINCIPAL REGISTER.

La Dolce Diva

3,282,287. REG. 8-21-2007. STRUCTUS BUILDING TECHNOLOGIES, INC. (WASHINGTON CORPORATION) 20870 REDSIDE COURT, BEND, OR. 97701, SN 77-087,048. FILED 1-19-2007. PRINCIPAL REGISTER.



NO CLAIM IS MADE TO THE EXCLUSIVE RIGHT TO USE "TECHNOLOGY", APART FROM THE MARK AS SHOWN.

THE MARK CONSISTS OF FIGURE OF MAN WITH BASEBALL BAT READY TO HIT. THE WORDS MADE WITH SLAM TECHNOLOGY APPEARS BELOW MAN.

INT. CL. 19/U.S. CLS. 1, 12, 33 AND 50

FOR DRYWALL CONSTRUCTION PRODUCTS, NAMELY, NON-METAL PREFINISHED DRYWALL TRIM PIECES, FLEXTRIM PIECES, BEADS, ENDCAPS AND CORNERS.

FIRST USE 9-1-2006; IN COMMERCE 1-1-2007.

ELEMENTS CORRECTED
OWNER ADDRESS
CITIZENSHIP

THE MARK CONSISTS OF STANDARD CHARACTERS WITHOUT CLAIM TO ANY PARTICULAR FONT, STYLE, SIZE, OR COLOR.

THE FOREIGN WORDING IN THE MARK TRANSLATES INTO ENGLISH AS SWEET.

INT. CL. 18/U.S. CLS. 1, 2, 3, 22 AND 41

FOR [LUGGAGE, TOTE BAGS, HAND BAGS, BEACH BAGS, ALL PURPOSE SPORT AND CARRYING BAGS, UMBRELLAS, SHOULDER BAGS, BACKPACKS,] TOILETRY KITS SOLD EMPTY, *NOT MADE OF LEATHER * [KEY CASES, LEATHER KEY CHAINS, AND WALLETS]

FIRST USE 7-1-2005; IN COMMERCE 11-1-2006.

INT. CL. 25/U.S. CLS. 22 AND 39

FOR CLOTHING, NAMELY, [SHIRTS, BLOUSES,] T-SHIRTS, [PANTS, SHORTS, OVERALLS, SHORTALLS, SWEATSHIRTS, JACKETS, COATS, SKIRTS, DRESSES, JUMPSUITS, JUMPERS, TOPS, SWEATERS, VESTS, HEADWEAR, HATS, CAPS, MITTENS, RAINCOATS, UNDERWEAR, NIGHT GOWNS, PAJAMAS, ROBES, CLOTH BABY BIBS, BABY BUNTING, INFANT WEAR, SWIM WEAR, BEACH WEAR, BEACH COVER UPS; ACCESSORIES, NAMELY, GLOVES, MITTENS, SCARVES, BELTS; LEOTARDS, SOCKS, BOOTIES AND FOOTWEAR]

FIRST USE 7-15-2005; IN COMMERCE 12-15-2006.

ELEMENTS AMENDED
GOODS/SERVICES

3,294,189. REG. 9-18-2007. ESCADA LUXEMBOURG S.À.R.L. (BENELUX S.À.R.L.) 65, BOULEVARD GRANDE-DUCHESSE CHARLOTTE, L-1331 LUXEMBOURG, LUXEMBOURG., SN 79-020,062. FILED 8-3-2005. PRINCIPAL REGISTER.

ESCADA - A GIRL'S BEST FRIEND

THE MARK CONSISTS OF STANDARD CHARACTERS WITHOUT CLAIM TO ANY PARTICULAR FONT, STYLE, SIZE, OR COLOR.

PRIORITY DATE OF 4-26-2005 IS CLAIMED.

OWNER OF INTERNATIONAL REGISTRATION 0874552 DATED 8-3-2005, EXPIRES 8-3-2015.

OWNER OF U.S. REG. NOS. 1,219,137, 3,007,556 AND OTHERS.

THE ENGLISH TRANSLATION OF THE WORD "ESCADA" IN THE MARK IS "STAIRS".

INT. CL. 9/U.S. CLS. 21, 23, 26, 36 AND 38

FOR SPECTACLES AND SUNGLASSES; APPARATUS FOR RECORDING TRANSMISSION AND REPRODUCTION OF SOUND OR IMAGES; PHOTOGRAPHIC FILM AND OPTICAL APPLIANCES AND INSTRUMENTS, NAMELY PHOTOGRAPHIC CAMERAS, FILM CAMERAS AND OPTICAL DISK DRIVES; OPTICAL MIRRORS, SCANNERS, BINOCULARS.

FIRST USE ; IN COMMERCE .

INT. CL. 14/U.S. CLS. 2, 27, 28 AND 50

FOR JEWELLERY, FASHION JEWELLERY, PRECIOUS STONES, CLOCKS AND WATCHES.
INT. CL. 18/U.S. CLS. 1, 2, 3, 22 AND 41

FOR GOODS MADE OF LEATHER AND LEATHER IMITATIONS, NAMELY BAGS AND OTHER CASES NOT ADAPTED TO THE PRODUCTS THEREIN INTENDED TO CONTAIN, NAMELY, HANDBAGS, OPERA BAGS, COSMETIC CASES SOLD EMPTY, BUSINESS CARD CASES OVERNIGHT CASES, SPORT BAGS; SMALL LEATHER ARTICLES, NAMELY PURSES, WALLETS, KEY CASES, TRAVELING BAGS AND TRUNKS, UMBRELLAS, PARASOLS.

FIRST USE ; IN COMMERCE .
INT. CL. 25/U.S. CLS. 22 AND 39

FOR CLOTHING, NAMELY TROUSERS, PANTS, DRESSES, GOWNS, BALL GOWNS, CATSUIITS, SKI SUITS, KNIT CARDIGAN SWEATERS, KNIT SHIRTS, KNIT SKIRTS, JEANS, HALF COATS, TRACK SUITS, PULLOVERS, PAJAMAS, BIKINIS, SWIMSUITS, CARDIGAN SWEATERS, SUITS, SKIRTS, SHIRTS, BLOUSES, COATS, JACKETS, SCARVES AND NECKTIES, SWEATERS, TEE SHIRTS, BODY STOCKINGS, UNDERWEAR, TIGHTS, SOCKS, SCARVES, SHAWLS, FOULARDS, KERCHIEFS, MUFFLERS; FOOTWEAR; HEADGEAR, NAMELY HATS AND CAPS.

FIRST USE ; IN COMMERCE .

ELEMENTS AMENDED
REGISTER

3,306,241. REG. 10-9-2007. BRAMMALL, INC. (INDIANA CORPORATION) 409 HOOSIER DRIVE, P.O. BOX 208, ANGOLA, IN, 46703, SN 77-096,995. FILED 2-1-2007. PRINCIPAL REGISTER.

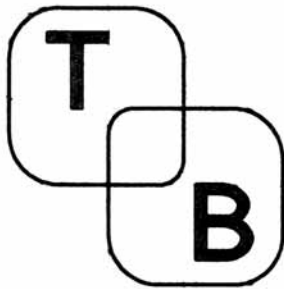

OWNER OF U.S. REG. NO. 2,347,661.
THE MARK CONSISTS OF THE LETTERS T AND B IN INTERLOCKING DESIGNS.

INT. CL. 6/U.S. CLS. 2, 12, 13, 14, 23, 25 AND 50
FOR METAL LOCKS.
FIRST USE 10-0-2006; IN COMMERCE 10-0-2006.
INT. CL. 20/U.S. CLS. 2, 13, 22, 25, 32 AND 50
FOR NON-METAL LOCKS .
FIRST USE 10-0-2006; IN COMMERCE 10-0-2006.

ELEMENTS CORRECTED
OWNER NAME
OWNER ADDRESS

3,312,946. REG. 10-16-2007. NET TRANSMIT & RECEIVE S.L. (SPAIN 99-SOCIEDAD LIMITADA (S.L.)) TORRES DIAGONAL LITORAL, JOSEP PLA 2-EDIFICIO B3, 1ª PLANTA E-08019 BARCELONA, SPAIN., SN 79-033,485. FILED 9-28-2006. PRINCIPAL REGISTER.



OWNER OF INTERNATIONAL REGISTRATION 0888013 DATED 3-15-2006, EXPIRES 3-15-2016.

NO CLAIM IS MADE TO THE EXCLUSIVE RIGHT TO USE "SUPPORT", APART FROM THE MARK AS SHOWN.

THE COLOR(S) LIGHT BLUE, DARK BLUE IS/ARE CLAIMED AS A FEATURE OF THE MARK.

"THE MARK CONSISTS OF A LIGHT BLUE SWIRL, THE LETTERS NTR IN DARK BLUE, AND THE WORD SUPPORT IN LIGHT BLUE LETTERS."

INT. CL. 9/U.S. CLS. 21, 23, 26, 36 AND 38

FOR COMPUTER PROGRAMS FOR USE IN PROVIDING REMOTE ACCESS TO AND CONTROL OFF-SITE COMPUTERS, INSTANT MESSAGING, AND A COLLABORATIVE PLATFORM FOR COMPANIES THAT CAN BE USED VIA A WEBPAGE * NOT USED FOR DISSEMINATION SERVICES OR NOT IN CONNECTION WITH SUCH SERVICES *.

FIRST USE ; IN COMMERCE .
INT. CL. 38/U.S. CLS. 100, 101 AND 104

FOR TELECOMMUNICATIONS AND COMMUNICATIONS SERVICES, NAMELY, COMMUNICATIONS VIA COMPUTER TERMINALS * NONE OF THE AFORESAID SERVICES USED FOR DISSEMINATION SERVICES OR IN CONNECTION WITH SUCH SERVICES *.

FIRST USE ; IN COMMERCE .
INT. CL. 42/U.S. CLS. 100 AND 101

FOR SCIENTIFIC AND TECHNOLOGICAL SERVICES AND THERETO RELATED RESEARCH AND DESIGN, ALL FOR THE DEVELOPMENT OF REMOTE CONTROL SOFTWARE; INDUSTRIAL ANALYSIS AND RESEARCH SERVICES FOR DEVELOPMENT OF SOFTWARE FOR REMOTE CONTROL; DESIGN AND DEVELOPMENT OF SOFTWARE FOR REMOTE CONTROL * NONE OF THE AFORESAID SERVICES USED FOR DISSEMINATION SERVICES OR IN CONNECTION WITH SUCH SERVICES *.

FIRST USE ; IN COMMERCE .

ELEMENTS CORRECTED
CITIZENSHIP
GOODS/SERVICES
OWNER ADDRESS
ENTITY

3,318,689. REG. 10-23-2007. NET TRANSMIT & RECEIVE S.L. (SPAIN SOCIEDAD LIMITADA (S.L.)) TORRES DIAGONAL LITORAL, JOSEP PLA 2-EDIFICIO B3, 1ª PLANTA E-08019 BARCELONA, SPAIN., SN 79-029,063. FILED 9-13-2006. PRINCIPAL REGISTER.



PRIORITY DATE OF 3-14-2006 IS CLAIMED.
OWNER OF INTERNATIONAL REGISTRATION 0898943 DATED 9-13-2006, EXPIRES 9-13-2016.

NO CLAIM IS MADE TO THE EXCLUSIVE RIGHT TO USE "ADMIN", APART FROM THE MARK AS SHOWN.

THE COLOR(S) GREEN, BLUE IS/ARE CLAIMED AS A FEATURE OF THE MARK.

THE MARK CONSISTS OF A GREEN SWIRL, THE LETTERS NTR IN BLUE, AND THE WORD ADMIN IN GREEN LETTERS.

INT. CL. 9/U.S. CLS. 21, 23, 26, 36 AND 38

FOR COMPUTER PROGRAMS FOR USE IN PROVIDING REMOTE ACCESS TO AND CONTROL OFF-SITE COMPUTERS, INSTANT MESSAGING, AND A COLLABORATIVE PLATFORM FOR COMPANIES THAT CAN BE USED VIA A WEBPAGE * NOT USED FOR DISSEMINATION SERVICES OR NOT IN CONNECTION WITH SUCH SERVICES *.

FIRST USE ; IN COMMERCE .
INT. CL. 38/U.S. CLS. 100, 101 AND 104

FOR TELECOMMUNICATIONS AND COMMUNICATIONS SERVICES, NAMELY, COMMUNICATIONS BY COMPUTER TERMINALS * NONE OF THE AFORESAID SERVICES USED FOR DISSEMINATION SERVICES OR IN CONNECTION WITH SUCH SERVICES *.

FIRST USE ; IN COMMERCE .
INT. CL. 42/U.S. CLS. 100 AND 101

FOR SCIENTIFIC AND TECHNOLOGICAL SERVICES AND RESEARCH AND DESIGN RELATING THERETO, ALL THE ABOVE FOR THE DEVELOPMENT OF REMOTE CONTROL SOFTWARE; INDUSTRIAL ANALYSIS AND RESEARCH SERVICES, ALSO FOR THE DEVELOPMENT OF REMOTE CONTROL SOFTWARE; DESIGN AND DEVELOPMENT OF REMOTE CONTROL SOFTWARE * NONE OF THE AFORESAID SERVICES USED FOR DISSEMINATION SERVICES OR IN CONNECTION WITH SUCH SERVICES *.

FIRST USE ; IN COMMERCE .

ELEMENTS CORRECTED
CITIZENSHIP
GOODS/SERVICES
OWNER ADDRESS
ENTITY

3,333,666. REG. 11-13-2007. POWER INTEGRATIONS, INC. (DELAWARE CORPORATION) 5245 HELLYER AVENUE, SAN JOSE, CA, 95138, SN 77-081,492. FILED 1-11-2007. PRINCIPAL REGISTER.

QSPEED

THE MARK CONSISTS OF STANDARD CHARACTERS WITHOUT CLAIM TO ANY PARTICULAR FONT, STYLE, SIZE, OR COLOR.

INT. CL. 9/U.S. CLS. 21, 23, 26, 36 AND 38
FOR SEMICONDUCTORS.
FIRST USE 7-0-2006; IN COMMERCE 7-0-2006.

ELEMENTS AMENDED
MARK
[DISCLAIMER]

3,358,423. REG. 12-25-2007. UNITED STEEL PRODUCTS COMPANY, INC. (MINNESOTA CORPORATION) SUITE 200, 14305 SOUTHCROSS DRIVE, BURNSVILLE, MN, 55306, SN 77-007,030. FILED 9-25-2006. PRINCIPAL REGISTER.

USP STRUCTURAL CONNECTORS

THE MARK CONSISTS OF STANDARD CHARACTERS WITHOUT CLAIM TO ANY PARTICULAR FONT, STYLE, SIZE, OR COLOR.

OWNER OF U.S. REG. NO. 2,929,329.

NO CLAIM IS MADE TO THE EXCLUSIVE RIGHT TO USE "STRUCTURAL CONNECTORS", APART FROM THE MARK AS SHOWN.

INT. CL. 1/U.S. CLS. 1

FOR EPOXY ADHESIVES AND SYNTHETIC RESINS FOR REPAIRING AND BONDING BUILDING MATERIALS TO CONCRETE, MASONRY, WOOD AND STEEL, NOT INCLUDING WATERPROOFING CHEMICAL COMPOSITIONS, PAINT, WOOD PRESERVATIVES, OR RUST PRESERVATIVES.

FIRST USE 2-28-2005; IN COMMERCE 2-28-2005.

ELEMENTS CORRECTED
OWNER NAME

3,368,206. REG. 1-15-2008. BRAMMALL, INC. (INDIANA CORPORATION) 409 HOOSIER DRIVE, P.O. BOX 208, ANGOLA, IN, 46703, SN 77-162,778. FILED 4-23-2007. PRINCIPAL REGISTER.



INT. CL. 6/U.S. CLS. 2, 12, 13, 14, 23, 25 AND 50
FOR METAL LOCKS.

FIRST USE 5-0-1998; IN COMMERCE 5-0-1998.
INT. CL. 20/U.S. CLS. 2, 13, 22, 25, 32 AND 50
FOR NON-METAL LOCKS.
FIRST USE 5-0-1998; IN COMMERCE 5-0-1998.

ELEMENTS CORRECTED
OWNER NAME
OWNER ADDRESS

3,370,780. REG. 1-15-2008. STRUCTUS BUILDING TECHNOLOGIES, INC. (WASHINGTON CORPORATION) 20870 REDSIDE COURT, BEND, OR, 97701, SN 78-916,579. FILED 6-26-2006. PRINCIPAL REGISTER.

SLAM TECHNOLOGY

THE MARK CONSISTS OF STANDARD CHARACTERS WITHOUT CLAIM TO ANY PARTICULAR FONT, STYLE, SIZE, OR COLOR.

NO CLAIM IS MADE TO THE EXCLUSIVE RIGHT TO USE "TECHNOLOGY", APART FROM THE MARK AS SHOWN.

INT. CL. 19/U.S. CLS. 1, 12, 33 AND 50

FOR DRYWALL CONSTRUCTION PRODUCTS, NAMELY, NON-METAL PREFINISHED DRYWALL TRIM PIECES, FLEXTRIM PIECES, BEADS, ENDCAPS AND CORNERS.

FIRST USE 1-1-2007; IN COMMERCE 1-1-2007.

ELEMENTS CORRECTED
CITIZENSHIP

3,378,900. REG. 2-5-2008. NET TRANSMIT & RECEIVE S.L. (SPAIN 99-SOCIEDAD LIMITADA (S.L.)) TORRES DIAGONAL LITORAL, JOSEP PLA 2-EDIFICIO B3, 1ª PLANTA E-08019 BARCELONA, SPAIN., SN 79-033,346. FILED 11-6-2006. PRINCIPAL REGISTER.



OWNER OF INTERNATIONAL REGISTRATION 0899976 DATED 3-15-2006, EXPIRES 3-15-2016.

NO CLAIM IS MADE TO THE EXCLUSIVE RIGHT TO USE "CONNECT", APART FROM THE MARK AS SHOWN. THE COLOR(S) GREEN, BLUE IS/ARE CLAIMED AS A FEATURE OF THE MARK.

THE MARK CONSISTS OF A GREEN SWIRL, THE LETTERS "NTR" IN BLUE, AND THE WORD "CONNECT" IN GREEN LETTERS.

INT. CL. 9/U.S. CLS. 21, 23, 26, 36 AND 38

FOR COMPUTER PROGRAMS FOR USE IN PROVIDING REMOTE ACCESS TO AND CONTROL OFF-SITE COMPUTERS, INSTANT MESSAGING, AND A COLLABORATIVE PLATFORM FOR COMPANIES THAT CAN BE USED VIA A WEBPAGE * NOT USED FOR DISSEMINATION SERVICES OR NOT IN CONNECTION WITH SUCH SERVICES *

FIRST USE ; IN COMMERCE .

INT. CL. 38/U.S. CLS. 100, 101 AND 104

FOR TELECOMMUNICATIONS AND COMMUNICATIONS SERVICES, NAMELY, COMMUNICATIONS BY COMPUTER TERMINALS AND DIGITAL COMMUNICATIONS AND COMMUNICATIONS VIA WORLDWIDE COMPUTER NETWORKS *NONE OF THE AFORESAID SERVICES USED FOR DISSEMINATION SERVICES OR IN CONNECTION WITH SUCH SERVICES *

FIRST USE ; IN COMMERCE .

INT. CL. 42/U.S. CLS. 100 AND 101

FOR SCIENTIFIC AND TECHNOLOGICAL SERVICES AND RESEARCH AND DESIGN RELATING THERETO, ALL THE ABOVE FOR THE DEVELOPMENT OF REMOTE CONTROL SOFTWARE; INDUSTRIAL ANALYSIS AND RESEARCH SERVICES; DESIGN AND DEVELOPMENT OF COMPUTER HARDWARE AND SOFTWARE * NONE OF THE AFORESAID SERVICES USED FOR DISSEMINATION SERVICES OR IN CONNECTION WITH SUCH SERVICES *

FIRST USE ; IN COMMERCE .

ELEMENTS CORRECTED
GOODS/SERVICES

3,420,031. REG. 4-29-2008. TNW CORPORATION (DELAWARE CORPORATION) 1250 BROADWAY, 26 FL, NEW YORK, NY, 10001, SN 78-672,357. FILED 7-18-2005. PRINCIPAL REGISTER.

RANCHO GRANDE

THE MARK CONSISTS OF STANDARD CHARACTERS WITHOUT CLAIM TO ANY PARTICULAR FONT, STYLE, SIZE, OR COLOR.

THE FOREIGN WORDING IN THE MARK TRANSLATES INTO ENGLISH AS BIG RANCH.

INT. CL. 16/U.S. CLS. 2, 5, 22, 23, 29, 37, 38 AND 50

FOR PREPAID TELEPHONE CALLING CARDS, NOT MAGNETICALLY ENCODED .
FIRST USE 8-24-2005; IN COMMERCE 8-24-2005.

ELEMENTS AMENDED

DBA/AKA

OWNER NAME

OWNER ADDRESS

CITIZENSHIP

ENTITY

3,432,676. REG. 5-20-2008. NIBCO INC. (INDIANA CORPORATION) 1516 MIDDLEBURY STREET, ELKHART, IN, 46515, SN 78-578,966. FILED 3-3-2005. PRINCIPAL REGISTER.

WING-IT

THE MARK CONSISTS OF STANDARD CHARACTERS WITHOUT CLAIM TO ANY PARTICULAR FONT, STYLE, SIZE, OR COLOR.

INT. CL. 6/U.S. CLS. 2, 12, 13, 14, 23, 25 AND 50

FOR METAL ANCHOR BOLTS * FOR EMBEDDING IN CONCRETE FOR SEISMIC BRACING *

FIRST USE 10-8-2007; IN COMMERCE 10-8-2007.

ELEMENTS AMENDED
GOODS/SERVICES

3,432,734. REG. 5-20-2008. NIBCO INC. (INDIANA CORPORATION) 1516 MIDDLEBURY STREET, ELKHART, IN, 46515, SN 78-642,371. FILED 6-2-2005. PRINCIPAL REGISTER.



INT. CL. 6/U.S. CLS. 2, 12, 13, 14, 23, 25 AND 50

FOR METAL ANCHOR BOLTS * FOR EMBEDDING IN CONCRETE FOR SEISMIC BRACING *

FIRST USE 10-8-2007; IN COMMERCE 10-8-2007.

ELEMENTS AMENDED
GOODS/SERVICES

3,460,308. REG. 7-8-2008. BRIGHAM YOUNG UNIVERSITY (UTAH CORPORATION) OFFICE OF THE GENERAL COUNSEL, A-357 ASB, PROVO, UT, 84602, SN 77-149,911. FILED 4-5-2007. PRINCIPAL REGISTER.

3,482,278. REG. 8-5-2008. STRUCTUS BUILDING TECHNOLOGIES, INC. (WASHINGTON CORPORATION) 20870 REDSIDE CT., BEND, OR, 97701, SN 78-796,536. FILED 1-21-2006. PRINCIPAL REGISTER.



OWNER OF U.S. REG. NOS. 1,581,409 AND 1,767,417.
 INT. CL. 25/U.S. CLS. 22 AND 39
 FOR CLOTHING, NAMELY, SHIRTS, T-SHIRTS, HATS, SWEATSHIRTS AND JERSEYS.
 FIRST USE 8-1-1998; IN COMMERCE 8-1-1998.
 INT. CL. 41/U.S. CLS. 100, 101 AND 107
 FOR EDUCATION SERVICES, NAMELY, PROVIDING COURSES OF INSTRUCTION AT THE UNIVERSITY LEVEL; ENTERTAINMENT SERVICES, NAMELY, ARRANGING AND CONDUCTING ATHLETIC COMPETITIONS; CULTURAL EVENTS, NAMELY, THEATER PRODUCTIONS, LIVE MUSICAL PERFORMANCES AND ART EXHIBITS.
 FIRST USE 8-1-1998; IN COMMERCE 8-1-1998.

ELEMENTS AMENDED
 MARK

3,468,528. REG. 7-15-2008. STRUCTUS BUILDING TECHNOLOGIES INC (WASHINGTON CORPORATION) 20870 REDSIDE COURT, BEND, OR, 97701, SN 77-010,231. FILED 9-29-2006. PRINCIPAL REGISTER.

ULTRA ARCH

THE MARK CONSISTS OF STANDARD CHARACTERS WITHOUT CLAIM TO ANY PARTICULAR FONT, STYLE, SIZE, OR COLOR.
 OWNER OF U.S. REG. NOS. 2,222,318, 2,292,468 AND 2,295,590.
 NO CLAIM IS MADE TO THE EXCLUSIVE RIGHT TO USE "ARCH", APART FROM THE MARK AS SHOWN.
 INT. CL. 19/U.S. CLS. 1, 12, 33 AND 50
 FOR DRYWALL CONSTRUCTION PRODUCTS, NAMELY, NON-METAL PREFINISHED TRIM PIECES, FLEXTRIM PIECES AND NON-METAL DRYWALL ARCH FINISHING PIECES.
 FIRST USE 10-25-2006; IN COMMERCE 10-25-2006.

ELEMENTS CORRECTED
 OWNER ADDRESS
 CITIZENSHIP

DOUBLE BARREL HOPPER

THE MARK CONSISTS OF STANDARD CHARACTERS WITHOUT CLAIM TO ANY PARTICULAR FONT, STYLE, SIZE, OR COLOR.
 NO CLAIM IS MADE TO THE EXCLUSIVE RIGHT TO USE "HOPPER", APART FROM THE MARK AS SHOWN.
 THE WORDING "DOUBLE BARREL" HAS NO MEANING IN A FOREIGN LANGUAGE.
 INT. CL. 7/U.S. CLS. 13, 19, 21, 23, 31, 34 AND 35
 FOR MACHINES, NAMELY, DRYWALL MUD HOPPERS.
 FIRST USE 5-1-2000; IN COMMERCE 5-1-2000.

ELEMENTS CORRECTED
 CITIZENSHIP

3,503,161. REG. 9-16-2008. UNITED STEEL PRODUCTS COMPANY, INC. (MINNESOTA CORPORATION) SUITE 200, 14305 SOUTHCROSS DRIVE, BURNSVILLE, MN, 55306, SN 78-943,105. FILED 8-2-2006. PRINCIPAL REGISTER.

GOLD COAT

THE MARK CONSISTS OF STANDARD CHARACTERS WITHOUT CLAIM TO ANY PARTICULAR FONT, STYLE, SIZE, OR COLOR.
 NO CLAIM IS MADE TO THE EXCLUSIVE RIGHT TO USE "COAT", APART FROM THE MARK AS SHOWN.
 INT. CL. 6/U.S. CLS. 2, 12, 13, 14, 23, 25 AND 50
 FOR COATED METAL CONNECTORS AND FASTENERS, NAMELY, ANCHORS, PLATES, BRACKETS, NAILS, SCREWS AND BOLTS FOR STRUCTURAL FRAMING, BUILDING, AND CONSTRUCTION.
 FIRST USE 2-23-2007; IN COMMERCE 2-23-2007.

ELEMENTS CORRECTED
 OWNER NAME

3,552,547. REG. 12-30-2008. BOULEVARDS NEW MEDIA, INC. (CALIFORNIA CORPORATION) 452 SOUTH FIRST STREET, SAN JOSE, CA, 95113, SN 77-151,144. FILED 4-6-2007. PRINCIPAL REGISTER.



THE MARK CONSISTS OF THE LETTERING "SANFRANCISCO.COM" AND A HEART ABOVE THE LETTERING WITH A BRIDGE OVER-LAPPING THE HEART.

AS TO "SANFRANCISCO.COM".

INT. CL. 35/U.S. CLS. 100, 101 AND 102

FOR PROVIDING ON-LINE DIRECTORY INFORMATION SERVICES ALSO FEATURING HYPERLINKS TO OTHER WEB SITES; PROVIDING AN ONLINE DIRECTORY INFORMATION SERVICE FEATURING INFORMATION REGARDING RESTAURANTS, BARS, HOTELS, TOURS AND ATTRACTIONS, EMPLOYMENT OPPORTUNITIES, AND EVENTS IN SAN FRANCISCO; ADVERTISING AND PUBLICITY SERVICES, NAMELY, PROMOTING THE GOODS, SERVICES, BRAND IDENTITY AND COMMERCIAL INFORMATION AND NEWS OF THIRD PARTIES THROUGH PRINT, AUDIO, VIDEO, DIGITAL AND ON-LINE MEDIUM.

FIRST USE 3-14-2007; IN COMMERCE 3-14-2007.

ELEMENTS CORRECTED
OWNER NAME

3,558,128. REG. 1-6-2009. BRAMMALL, INC. (INDIANA CORPORATION) 409 HOOSIER DRIVE, P.O. BOX 208, ANGOLA, IN, 46703, SN 77-097,013. FILED 2-1-2007. PRINCIPAL REGISTER.

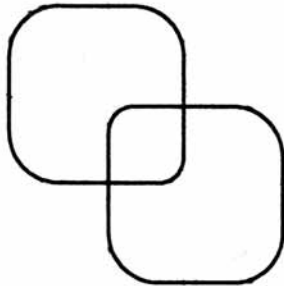

OWNER OF U.S. REG. NO. 2,347,661.
THE MARK CONSISTS OF INTERLOCKING FOUR-SIDED DESIGNS.

INT. CL. 6/U.S. CLS. 2, 12, 13, 14, 23, 25 AND 50

FOR METAL LOCKS.
FIRST USE 10-0-2006; IN COMMERCE 10-0-2006.

INT. CL. 20/U.S. CLS. 2, 13, 22, 25, 32 AND 50

FOR NON-METAL LOCKS.
FIRST USE 11-15-2005; IN COMMERCE 11-15-2005.

ELEMENTS CORRECTED
OWNER NAME
OWNER ADDRESS

3,586,369. REG. 3-10-2009. NEW DAWN TECHNOLOGIES (UTAH CORPORATION) 843 SOUTH 100 WEST, LOGAN, UT, 84321, SN 77-531,315. FILED 7-25-2008. PRINCIPAL REGISTER.



THE MARK CONSISTS OF A STYLIZED COURTHOUSE COLUMN PRIOR TO THE THE ENTIRE WORD "JUSTWARE". THE "J" AND "W" ARE UPPER-CASED WITH THE "JS" LIGATURE EXTENDED BELOW THE BASELINE. THE OTHER LETTERS "UST" AND "ARE" APPEAR IN SMALL CAPS AND HAVE VARIATION IN WEIGHT FROM THICK TO THIN.

INT. CL. 9/U.S. CLS. 21, 23, 26, 36 AND 38

FOR COMPUTER SOFTWARE FOR USE IN CASE MANAGEMENT, DOCUMENT AUTOMATION, AND FINANCIAL TRACKING.

FIRST USE 1-1-2007; IN COMMERCE 1-1-2007.

ELEMENTS AMENDED
DESCRIPTION OF MARK
MARK
[COLOR DESCRIPTION STATEMENT]

3,588,790. REG. 3-10-2009. URODA, SUSAN (UNITED STATES INDIVIDUAL) #2, 360 CHINQUAPIN AVENUE, CARLSBAD, CA, 92008, SN 77-460,463. FILED 4-29-2008. PRINCIPAL REGISTER.

Jump Girl

THE MARK CONSISTS OF STANDARD CHARACTERS WITHOUT CLAIM TO ANY PARTICULAR FONT, STYLE, SIZE, OR COLOR.

NO CLAIM IS MADE TO THE EXCLUSIVE RIGHT TO USE "GIRL", APART FROM THE MARK AS SHOWN.

INT. CL. 25/U.S. CLS. 22 AND 39

FOR * CLOTHING, NAMELY, * BELTS; HATS; PANTS AND T-SHIRTS, * ALL OF THE FOREGOING FOR USE IN EQUESTRIAN SPORTS *.

FIRST USE 3-17-2008; IN COMMERCE 10-27-2008.

ELEMENTS AMENDED
GOODS/SERVICES

3,606,197. REG. 4-14-2009. SUMCO CORPORATION (JAPAN CORPORATION) 1-2-1 SHIBAURA, MINATO-KU, TOKYO 105-8634, JAPAN,, SN 79-050,413. FILED 1-30-2008. PRINCIPAL REGISTER.

FORMOSA SUMCO TECHNOLOGY

THE MARK CONSISTS OF STANDARD CHARACTERS WITHOUT CLAIM TO ANY PARTICULAR FONT, STYLE, SIZE, OR COLOR.

PRIORITY DATE OF 7-31-2007 IS CLAIMED.
OWNER OF INTERNATIONAL REGISTRATION 0954791 DATED 1-30-2008, EXPIRES 1-30-2018.

OWNER OF U.S. REG. NOS. 2,880,968 AND 2,992,782.
NO CLAIM IS MADE TO THE EXCLUSIVE RIGHT TO USE "FORMOSA" AND "TECHNOLOGY", APART FROM THE MARK AS SHOWN.

THE FOREIGN WORDING IN THE MARK TRANSLATES INTO ENGLISH AS "TAIWAN".
INT. CL. 9/U.S. CLS. 21, 23, 26, 36 AND 38

FOR SOLAR CELLS; SILICON WAFERS FOR SOLAR CELLS; SEMICONDUCTOR WAFERS, NAMELY, COMPOUND SEMICONDUCTOR WAFERS, SOI (SILICON-ON-INSULATOR) WAFERS, AND STRAINED SILICON WAFERS; SEMICONDUCTOR SILICON WAFERS; SINGLE-CRYSTAL SILICON WAFERS [; INGOTS OF SEMICONDUCTOR SILICON FOR MAKING SILICON WAFERS; SINGLE-CRYSTAL SILICON INGOTS FOR INTEGRATED CIRCUITS].

FIRST USE ; IN COMMERCE .

ELEMENTS CORRECTED
GOODS/SERVICES

3,636,961. REG. 6-9-2009. BIGELOW MERCHANDISING, LLC (DELAWARE LIMITED LIABILITY COMPANY) THREE LIMITED PARKWAY, COLUMBUS, OH, 43230, SN 78-981,079. FILED 6-8-2004. PRINCIPAL REGISTER.

C.O. BIGELOW

THE MARK CONSISTS OF STANDARD CHARACTERS WITHOUT CLAIM TO ANY PARTICULAR FONT, STYLE, SIZE, OR COLOR.

OWNER OF U.S. REG. NOS. 2,365,803, 2,460,091 AND 2,915,656.

THE NAME "C.O. BIGELOW" DOES NOT IDENTIFY A LIVING INDIVIDUAL.

SEC. 2(F).

INT. CL. 3/U.S. CLS. 1, 4, 6, 50, 51 AND 52

FOR PERSONAL CARE PRODUCTS, NAMELY, AFTER SHAVE, AFTER SHAVE BALM, NON-MEDICATED FACIAL CUT AND NICK TREATMENT BLOCK, COSMETIC ASTRINGENT FOR THE FACE AND SKIN, NON-MEDICATED BATH SOAKS, NON-MEDICATED SKIN AND FACE BALM, FACIAL AND SKIN CLEANSERS, BODY CREAMS, BODY LOTION, SKIN MOISTURIZERS, BODY AND BEAUTY CARE PREPARATIONS, NAMELY, NON-MEDICATED BODY OINTMENTS AND SALVE, BODY SCRUB, COLD CREAM, HAIR CONDITIONER, ESSENTIAL OILS FOR PERSONAL USE, EYE CREAM, EYE GEL, FACE CLEANSERS, FACE LOTION, FACE MASKS, FACE MIST, FACE MOISTURIZERS, FACE SCRUBS, NON-MEDICATED FACE SERUM, FACE TONERS, FOOT CREAM, NON-MEDICATED FOOT POWDER, FRAGRANCES FOR PERSONAL USE, HAIR STYLING PREPARATIONS, HAND CLEANSERS, HAND LOTIONS, LIP BALMS, LIP EXFOLIATOR, NON-MEDICATED LIP CARE PREPARATIONS, NON-MEDICATED LIP TREATMENTS, LIQUID CLEANSERS FOR THE FACE AND SKIN, NON-MEDICATED MOUTHWASH, NON-MEDICATED NOSE BALM, SHAMPOO, SHAVE CREAMS, SHOWER GEL, MEDICATED SOAPS.

FIRST USE 1-19-2005; IN COMMERCE 1-19-2005.

INT. CL. 5/U.S. CLS. 6, 18, 44, 46, 51 AND 52

FOR ACNE TREATMENT PREPARATIONS, ANTI-ITCH LOTION, ANTI-ITCH CREAM, ANTI-ITCH OINTMENT, MEDICATED FOOT POWDER, MEDICATED LIP SALVE, MEDICATED MOUTHWASH, STYPTIC PENCILS, AND MEDICINAL ASTRINGENT FOR THE FACE AND SKIN.

FIRST USE 1-19-2005; IN COMMERCE 1-19-2005.

INT. CL. 8/U.S. CLS. 23, 28 AND 44

FOR NAIL CLIPPERS, NAIL FILE, NAIL SCISSORS, RAZOR BLADES, NON-ELECTRIC RAZORS AND TWEEZERS.

FIRST USE 1-19-2005; IN COMMERCE 1-19-2005.

INT. CL. 30/U.S. CL. 46

FOR CHEWING GUM, MINTS AND PASTILLES.

FIRST USE 1-19-2005; IN COMMERCE 1-19-2005.

INT. CL. 35/U.S. CLS. 100, 101 AND 102

FOR MAIL ORDER SERVICES, ONLINE RETAIL STORE SERVICES, RETAIL STORE SERVICES, ALL FEATURING MEDICATED PERSONAL CARE PRODUCTS, PERSONAL CARE PRODUCTS, COSMETICS, TOILETRIES, SPA, SKIN AND BEAUTY CARE PRODUCTS, HOME FRAGRANCE PRODUCTS AND PERSONAL CARE ACCESSORIES.

FIRST USE 1-19-2005; IN COMMERCE 1-19-2005.

INT. CL. 45/U.S. CLS. 100 AND 101

FOR PREPARATION OF CUSTOM GIFT BASKETS WITH SELECTED COSMETIC, BODY CARE ITEMS, HOME FRAGRANCE AND PERSONAL CARE ACCESSORIES.

FIRST USE 1-19-2005; IN COMMERCE 1-19-2005.

ELEMENTS CORRECTED
GOODS/SERVICES

3,639,768. REG. 6-16-2009. FRAUNHOFER-GESELLSCHAFT ZUR; FÖRDERUNG DER ANGEWANDTEN FORSCHUNG E.V. (FED REP GERMANY INCORPORATED ASSOCIATION) HANSASTRASSE 27C, 80686 MÜNCHEN, FED REP GERMANY., SN 79-055,481. FILED 4-18-2008. PRINCIPAL REGISTER.

awiloc

THE MARK CONSISTS OF STANDARD CHARACTERS WITHOUT CLAIM TO ANY PARTICULAR FONT, STYLE, SIZE, OR COLOR.

PRIORITY DATE OF 10-25-2007 IS CLAIMED.

OWNER OF INTERNATIONAL REGISTRATION 0968791 DATED 4-18-2008, EXPIRES 4-18-2018.

INT. CL. 9/U.S. CLS. 21, 23, 26, 36 AND 38

FOR [EQUIPMENT FOR RECORDING, TRANSFERRING AND REPRODUCTION OF AUDIO, DATA AND PICTURES; ELECTRONIC TRANSMISSION AND RECEIVER DEVICES FOR ELECTRONIC, ACOUSTIC OR OPTICAL SIGNALS;] ELECTRONIC GAME CONSOLES AS ADDITIONAL EQUIPMENT FOR TELEVISIONS; DATA PROCESSING MACHINES AND COMPUTERS; COMPUTER PROGRAMS FOR USE IN LOCALIZATION, NAVIGATION, POSITION DETERMINATION AND TRACKING OF PERSONS AND OBJECTS, FOR LOCATION BASED SERVICES, AND FOR ACQUISITION, TRANSMISSION AND PRESENTATION OF POSITION INFORMATION; ELECTRONIC INTERFACE EQUIPMENT FOR MACHINE TOOLS TO INPUT OR OUTPUT COMPUTER NUMERICAL CONTROL DATA; INTERFACES FOR COMPUTERS; COMPUTER MEMORIES, BLANK MAGNETIC DATA CARRIERS [; SEMICONDUCTOR MEMORIES] * FOR COMPUTER PROGRAMS, IN PARTICULAR FOR LOCALIZATION, NAVIGATION, POSITION DETERMINATION AND TRACKING OF PERSONS AND OBJECTS.

FIRST USE ; IN COMMERCE .

INT. CL. 38/U.S. CLS. 100, 101 AND 104

FOR TELECOMMUNICATIONS BY E-MAIL, PROVIDING ELECTRONIC TELECOMMUNICATIONS CONNECTIONS, INFORMATION ABOUT TELECOMMUNICATION; TELECONFERENCING SERVICES; TRANSMISSION OF NEWS.

INT. CL. 41/U.S. CLS. 100, 101 AND 107

FOR EDUCATIONAL SERVICES, NAMELY, PROVIDING COURSES, SEMINARS, WORKSHOPS, SYMPOSIUMS, CONGRESSES AND CONFERENCES IN THE USE OF COMPUTERS AND DATA PROCESSORS AND COMPUTER EDUCATION TRAINING.

INT. CL. 42/U.S. CLS. 100 AND 101

FOR COMPUTER SOFTWARE DESIGN FOR OTHERS; DESIGN AND DEVELOPMENT OF COMPUTER HARDWARE AND SOFTWARE; SCIENTIFIC RESEARCH; INDUSTRIAL RESEARCH IN THE FIELD OF COMPUTER HARDWARE AND SOFTWARE; SCIENTIFIC AND TECHNICAL CONSULTANCY, NAMELY, CONSULTING IN THE FIELD OF INFORMATION TECHNOLOGY; CONSULTING SERVICES IN THE FIELD OF DESIGN, SELECTION, IMPLEMENTATION AND USE OF COMPUTER HARDWARE AND SOFTWARE SYSTEMS FOR OTHERS; COMPUTER SOFTWARE DEVELOPMENT FEATURING PROGRAMS FOR DATA PROCESSING AND FOR LOCALIZATION, NAVIGATION, POSITION DETERMINATION AND TRACKING OF PERSONS AND OBJECTS; COMPUTER PROGRAMMING AND COMPUTER SOFTWARE DESIGN OF COMPUTER PROGRAMS FOR USE IN DATA NETWORKS; COMPUTER HARDWARE AND SOFTWARE CONSULTATION SERVICES; DEVELOPMENT OF COMPUTER HARDWARE; MAINTENANCE AND INSTALLATION OF SOFTWARE.

ELEMENTS CORRECTED
GOODS/SERVICES

3,641,355. REG. 6-16-2009. BIGELOW MERCHANDISING, LLC (DELAWARE LIMITED LIABILITY COMPANY) THREE LIMITED PARKWAY, COLUMBUS, OH, 43230, SN 78-981,078. FILED 6-8-2004. PRINCIPAL REGISTER.



OWNER OF U.S. REG. NOS. 2,365,803, 2,802,209 AND 2,915,656.

NO CLAIM IS MADE TO THE EXCLUSIVE RIGHT TO USE "ESTABLISHED 1838 APOTHECARIES", APART FROM THE MARK AS SHOWN.

THE NAME "C.O. BIGELOW" DOES NOT IDENTIFY A LIVING INDIVIDUAL.

AS TO "C. O. BIGELOW".

INT. CL. 3/U.S. CLS. 1, 4, 6, 50, 51 AND 52

FOR PERSONAL CARE PRODUCTS, NAMELY, AFTER SHAVE BALM, NON-MEDICATED FACIAL CUT AND NICK TREATMENT BLOCK, COSMETIC ASTRINGENT FOR THE FACE AND SKIN, NON-MEDICATED BATH SOAKS, NON-MEDICATED SKIN AND FACE BALM, FACIAL AND SKIN CLEANSERS, BODY CREAMS, BODY LOTION, SKIN MOISTURIZERS, BODY AND BEAUTY CARE PREPARATIONS, NAMELY, NON-MEDICATED BODY OINTMENTS AND SALVE, BODY SCRUB, COLD CREAM, EYE CREAM, EYE GEL, FACE CLEANSERS, FACE LOTION, FACE MASKS, FACE MIST, FACE MOISTURIZERS, FACE SCRUBS, NON-MEDICATED FACE SERUM, FACE TONERS, FOOT CREAM, NON-MEDICATED FOOT POWDER, HAND CLEANSERS, HAND CREAM, HAND LOTIONS, LIP EXFOLIATOR, NON-MEDICATED LIP CARE PREPARATIONS, NON-MEDICATED LIP TREATMENTS, NON-MEDICATED MOUTHWASH, NON-MEDICATED NOSE BALM.

FIRST USE 1-19-2005; IN COMMERCE 1-19-2005.

INT. CL. 5/U.S. CLS. 6, 18, 44, 46, 51 AND 52

FOR ACNE TREATMENT PREPARATIONS, ANTI-ITCH LOTION, ANTI-ITCH CREAM, ANTI-ITCH OINTMENT, MEDICATED FOOT POWDER, MEDICATED LIP SALVE, MEDICATED MOUTHWASH, STYPTIC PENCILS, MEDICINAL ASTRINGENT FOR THE FACE AND SKIN.

FIRST USE 1-19-2005; IN COMMERCE 1-19-2005.

ELEMENTS CORRECTED
GOODS/SERVICES

3,656,322. REG. 7-21-2009. RAVENSBURGER AKTIENGESELLSCHAFT (FED REP GERMANY CORPORATION) ROBERT-BOSCH-STR. 1, RAVENSBURG 88214, FED REP GERMANY., SN 77-076,651. FILED 1-5-2007. PRINCIPAL REGISTER.



NO CLAIM IS MADE TO THE EXCLUSIVE RIGHT TO USE "PAINTING BY NUMBERS" OR "JUNIOR", APART FROM THE MARK AS SHOWN.

THE COLOR(S) GOLD, PURPLE, BLUE, ORANGE, RED, GREEN, WHITE AND GREY IS/ARE CLAIMED AS A FEATURE OF THE MARK.

THE MARK CONSISTS OF THE COLORS PURPLE, BLUE, ORANGE, RED AND GREEN APPEAR IN THE WORDING "JUNIOR"; THE COLOR PURPLE APPEARS IN THE WORDING "PAINTING BY NUMBERS" AND "ANYONE CAN PAINT!"; THE COLORS WHITE AND BLUE APPEAR IN THE OUTLINING OF THE WORD "JUNIOR"; THE COLOR WHITE ALSO APPEARS IN THE DESIGN ELEMENT CONSISTING OF A STAR; THE COLORS GOLD AND GREY APPEAR ON THE DESIGN OF THE PAINTER'S PALETTE; THE COLOR GREY IS ALSO USED TO SHADE THE OUTLINING OF THE PAINTER'S PALETTE.

INT. CL. 16/U.S. CLS. 2, 5, 22, 23, 29, 37, 38 AND 50

FOR PAPER, CARDBOARD, AND GOODS MADE FROM PAPER AND CARDBOARD, NAMELY, DRAWING PAPER, CRAFT PAPER, CARDBOARD BOXES, CARDBOARD CARTONS, ARTISTS' PAPER, WRITING PAPER; PRINTED PRODUCTS, NAMELY, ACTIVITY BOOKS AND ART BOOKS; BOOKBINDING MATERIAL; PHOTOGRAPHS; STATIONERY; ADHESIVES FOR STATIONERY OR HOUSEHOLD USE; ARTISTS' MATERIALS, NAMELY, BRUSHES, PASTELS, PENS, PENCILS, CANVAS PANELS; PAINTBRUSHES; INSTRUCTIONAL AND TEACHING MATERIAL IN THE FIELD OF ART INSTRUCTION; PRINTERS' TYPE; PRINTING BLOCKS.

FIRST USE 2-1-2006; IN COMMERCE 2-1-2006.

INT. CL. 28/U.S. CLS. 22, 23, 38 AND 50

FOR TOYS, GAMES AND PLAYTHINGS, NAMELY, ART ACTIVITY TOYS, TOY PAINTING PLAYSETS.

FIRST USE 2-1-2006; IN COMMERCE 2-1-2006.

ELEMENTS CORRECTED
OWNER ADDRESS

3,659,756. REG. 7-28-2009. ARGUS MEDIA LIMITED (UNITED KINGDOM CORPORATION) 175 ST. JOHN STREET, LONDON, UNITED KINGDOM, EC1V 4LW, SN 77-175,656. FILED 5-8-2007. PRINCIPAL REGISTER.

ENERGY ARGUS

THE MARK CONSISTS OF STANDARD CHARACTERS WITHOUT CLAIM TO ANY PARTICULAR FONT, STYLE, SIZE, OR COLOR.

OWNER OF U.S. REG. NOS. 2,387,568, 2,450,022 AND 2,562,712.

AS TO "ENERGY".

INT. CL. 9/U.S. CLS. 21, 23, 26, 36 AND 38

FOR ELECTRONIC PUBLICATIONS, NAMELY, JOURNALS, NEWSLETTERS, REPORTS, NEWSPAPERS, PAMPHLETS, PERIODICALS, MAGAZINES AND MANUALS PROVIDING PRICING INFORMATION INCLUDING INDICES, RESEARCH ANALYSIS AND NEWS ABOUT ENERGY * * EMISSIONS, COMMODITIES AND TRANSPORTATION MARKETS AND NOT INCLUDING INFORMATION CONCERNING ASSET MANAGEMENT AND INVESTMENT ADVICE RELATING TO SECURITIES IN ELECTRONIC FORMAT DOWNLOADABLE FROM AND MADE AVAILABLE VIA A GLOBAL COMPUTER NETWORK ON A SUBSCRIPTION BASIS.
FIRST USE 5-0-1999; IN COMMERCE 5-0-1999.

ELEMENTS CORRECTED
OWNER ADDRESS

3,707,627. REG. 11-10-2009. AIR CHINA LIMITED (CHINA LIMITED LIABILITY COMPANY) 9TH FLOOR LANTIAN MANSION, 28 TIANZHU RD, SHUNYI, BEIJING, CHINA., SN 77-575,252. FILED 9-22-2008. PRINCIPAL REGISTER.



OWNER OF U.S. REG. NO. 1,610,138.
THE MARK CONSISTS OF A DESIGNED BIRD DEVICE.
INT. CL. 39/U.S. CLS. 100 AND 105
FOR AIR TRANSPORT; ARRANGING OF TOURS; [CAR TRANSPORT;] CHAUFFEUR SERVICES; DELIVERY AND STORAGE OF GOODS; [DISTRIBUTION OF ENERGY; MARINE TRANSPORT;] PARCEL DELIVERY; PASSENGER TRANSPORT; PILOTING; STORAGE OF GOODS; TRANSPORT AND DELIVERY OF GOODS; TRANSPORT BROKERAGE; TRANSPORT OF PASSENGERS.
FIRST USE 7-1-1988; IN COMMERCE 7-1-1988.

ELEMENTS AMENDED
GOODS/SERVICES

3,718,844. REG. 12-1-2009. EMSLAND-STÄRKE GMBH (FED REP GERMANY GESELLSCHAFT MIT BESCHRÄNKTER HAFTUNG (GMBH)) EMSLANDSTRASSE 58, 49824 EMLICHHEIM, FED REP GERMANY., SN 79-066,099. FILED 2-3-2009. PRINCIPAL REGISTER.

EMBALANCE

THE MARK CONSISTS OF STANDARD CHARACTERS WITHOUT CLAIM TO ANY PARTICULAR FONT, STYLE, SIZE, OR COLOR.
PRIORITY DATE OF 12-18-2008 IS CLAIMED.
OWNER OF INTERNATIONAL REGISTRATION 0995566 DATED 2-3-2009, EXPIRES 2-3-2019.
INT. CL. 1/U.S. CLS. 1

FOR STARCH FOR INDUSTRIAL PURPOSES, NAMELY, FOR USE IN THE MANUFACTURE OF PAPER AND TEXTILES.

INT. CL. 5/U.S. CLS. 6, 18, 44, 46, 51 AND 52

FOR DIETARY FIBER AS AN ADDITIVE FOR FOOD PRODUCTS; NUTRITIONAL SUPPLEMENTS MADE OF STARCH * FOR MEDICAL PURPOSES *.

FIRST USE ; IN COMMERCE .

INT. CL. 30/U.S. CL. 46

FOR STARCH FOR FOOD PURPOSES; FOOD PREPARATIONS MADE OF STARCH AND STARCH PRODUCTS, NAMELY, BREAD, CAKES, CEREAL PREPARATIONS, CHOCOLATE, DRESSINGS FOR SALAD, ICE CREAMS, PASTA, OAT FLAKES, PASTRY, PUDDINGS, SAUCES AND FROZEN CONFECTIONERY; FOOD PREPARATIONS MADE OF STARCH FIBERS WITH A HIGH ROUGHAGE CONTENT, NAMELY, BREAD, CAKES, CEREAL PREPARATIONS, CHOCOLATE, DRESSINGS FOR SALAD, ICE CREAM, PASTA, OAT FLAKES, PASTRY, PUDDINGS, SAUCES AND CONFECTIONERY CHIPS FOR BAKING, FROZEN CONFECTIONERY * FOR NONMEDICAL PURPOSES *.

FIRST USE ; IN COMMERCE .

ELEMENTS CORRECTED
GOODS/SERVICES

3,765,982. REG. 3-30-2010. BLUESTEM BRANDS, INC. (DELAWARE CORPORATION) 6509 FLYING CLOUD DRIVE, EDEN PRAIRIE, MN, 55344, SN 77-600,313. FILED 10-24-2008. PRINCIPAL REGISTER.

TESTMARK

THE MARK CONSISTS OF STANDARD CHARACTERS WITHOUT CLAIM TO ANY PARTICULAR FONT, STYLE, SIZE, OR COLOR.

INT. CL. 8/U.S. CLS. 23, 28 AND 44

FOR HAND TOOL SETS COMPRISING WRENCHES, PLIERS, HEX BITS, HEX KEYS, HAMMER, UTILITY KNIVES AND BLADES, MEASURING TAPE, SCREWDRIVERS .

FIRST USE 8-18-2009; IN COMMERCE 8-18-2009.

ELEMENTS CORRECTED
OWNER NAME

3,773,949. REG. 4-13-2010. SHOE BRANDING EUROPE BVBA (BELGIUM BVBA) LINDESTRAAT 58, B-9700 OUDENAARDE, BELGIUM., SN 77-499,772. FILED 6-16-2008. PRINCIPAL REGISTER.



OWNER OF DENMARK REG. NO. VR20030412, DATED 12-15-2003, EXPIRES 12-15-2013.

OWNER OF U.S. REG. NOS. 1,110,924 AND 1,392,430.

THE MARK CONSISTS OF STYLIZED "P" AND THE WORD "PATRICK".

INT. CL. 18/U.S. CLS. 1, 2, 3, 22 AND 41

FOR LEATHER AND IMITATION LEATHER SPORT BAGS AND GENERAL PURPOSE TROLLEYS BAGS; SPORT BAGS; GENERAL PURPOSE SPORT TROLLEY BAGS; TRAVELLING BAGS.

INT. CL. 25/U.S. CLS. 22 AND 39

FOR CLOTHING, NAMELY, SPORTS AND LEISURE WEAR, NAMELY, JOGGING SUITS, JOGGING SHIRTS, TRACKSUITS, SHORTS, TIGHTS, SWIMWEAR, TOPS, BOTTOMS, T-SHIRTS, RUGBY SHIRTS, POLO SHIRTS, SWEAT SHIRTS, LIGHTWEIGHT JACKETS MADE OF WIND-RESISTANT MATERIAL, PADDED JACKETS, RAIN JACKETS, EUROPEAN AND AMERICAN FOOTBALL BIBS, GLOVES, SOCKS; FOOTWEAR; FOOTWEAR FOR SPORTS AND OUTDOOR ACTIVITIES AND ACCESSORIES FOR SPORT SHOES, NAMELY, CLEATS, TIPS AND INNER SOLES; HEADWEAR.

FIRST USE ; IN COMMERCE .

INT. CL. 28/U.S. CLS. 22, 23, 38 AND 50

FOR ATHLETIC EQUIPMENT, NAMELY, BAGS AND TROLLEYS BAGS SPECIFICALLY ADAPTED FOR SPORTS EQUIPMENT, ARM BANDS FOR DESIGNATING TEAM MEMBER POSITIONS IN SPORTS ACTIVITIES, GOALKEEPERS' GLOVES, SPORT BALLS, HEAD GUARDS FOR RUGBY TRAINING PURPOSES, BODY PROTECTORS FOR RUGBY TRAINING PURPOSES.

FIRST USE ; IN COMMERCE .

ELEMENTS CORRECTED
OWNER NAME
OWNER ADDRESS
CITIZENSHIP
ENTITY

3,788,368. REG. 5-11-2010. JACKIE SQUARED, INC. (FLORIDA CORPORATION) 422 SIXTH AVENUE SOUTH, JACKSONVILLE BEACH, FL, 32250, SN 77-669,476. FILED 2-12-2009. PRINCIPAL REGISTER.

SHOWFILES

THE MARK CONSISTS OF STANDARD CHARACTERS WITHOUT CLAIM TO ANY PARTICULAR FONT, STYLE, SIZE, OR COLOR.

INT. CL. 41/U.S. CLS. 100, 101 AND 107

FOR ENTERTAINMENT SERVICES, NAMELY, PROVIDING A WEB SITE FEATURING PHOTOGRAPHIC, VIDEO AND PROSE PRESENTATIONS FEATURING DOGS AND DOG SHOWS.

FIRST USE 3-1-2010; IN COMMERCE 3-1-2010.

ELEMENTS CORRECTED
OWNER NAME
ENTITY

3,789,888. REG. 5-18-2010. JAMES J. RIZZI, INC. (NEW YORK CORPORATION) 284 LAFAYETTE STREET, NEW YORK, NY, 10012, SN 77-831,347. FILED 9-21-2009. PRINCIPAL REGISTER.

JAMES RIZZI

THE MARK CONSISTS OF STANDARD CHARACTERS WITHOUT CLAIM TO ANY PARTICULAR FONT, STYLE, SIZE, OR COLOR.

THE NAME "JAMES RIZZI" IDENTIFIES A LIVING INDIVIDUAL WHOSE CONSENT IS OF RECORD.

INT. CL. 11/U.S. CLS. 13, 21, 23, 31 AND 34

FOR LAMPS.

FIRST USE 2-1-2004; IN COMMERCE 2-1-2004.

INT. CL. 16/U.S. CLS. 2, 5, 22, 23, 29, 37, 38 AND 50

FOR CALENDARS, GREETING CARDS, ART BOOKS.

FIRST USE 9-15-2003; IN COMMERCE 9-15-2003.

INT. CL. 18/U.S. CLS. 1, 2, 3, 22 AND 41

FOR UMBRELLAS.

FIRST USE 1-15-1991; IN COMMERCE 1-15-1991.

INT. CL. 21/U.S. CLS. 2, 13, 23, 29, 30, 33, 40 AND 50

FOR DISHES OF CHINA, GLASS DISHES, THERMAL INSULATED CONTAINERS FOR FOOD OR BEVERAGE.

FIRST USE 5-1-2008; IN COMMERCE 5-1-2008.

INT. CL. 26/U.S. CLS. 37, 39, 40, 42 AND 50

FOR ORNAMENTAL NOVELTY BUTTONS.

FIRST USE 6-1-1993; IN COMMERCE 6-1-1993.

INT. CL. 28/U.S. CLS. 22, 23, 38 AND 50

FOR STUFFED TOY ANIMALS; PUZZLES.

FIRST USE 2-15-2001; IN COMMERCE 2-15-2001.

INT. CL. 34/U.S. CLS. 2, 8, 9 AND 17

FOR CIGARETTE LIGHTERS NOT FOR LAND VEHICLES.

FIRST USE 5-1-1987; IN COMMERCE 5-1-1987.

ELEMENTS CORRECTED
OWNER NAME

3,809,992. REG. 6-29-2010. STREET LAW, INC. (D.C. CORPORATION) 101 WAYNE AVENUE, SILVER SPRING, MD, 20910, SN 77-857,266. FILED 10-26-2009. PRINCIPAL REGISTER.

BREAKFAST WITH A LEGEND

THE MARK CONSISTS OF STANDARD CHARACTERS WITHOUT CLAIM TO ANY PARTICULAR FONT, STYLE, SIZE, OR COLOR.

INT. CL. 16/U.S. CLS. 2, 5, 22, 23, 29, 37, 38 AND 50

FOR BLANK JOURNALS; BOOKMARKS; EDUCATIONAL PUBLICATIONS, NAMELY, TRAINING MANUALS IN THE FIELD OF ORGANIZING, CONDUCTING, AND EVALUATING PROGRAMS FEATURING EDUCATIONAL AND MOTIVATIONAL SPEAKERS; EDUCATIONAL PUBLICATIONS, NAMELY, LESSON PLANS IN THE FIELDS OF LAW, [DEMOCRACY, HUMAN RIGHTS, CRIME PREVENTION,] DISPUTE RESOLUTION [COMMUNITY LEADERSHIP, AND CITIZENSHIP;] PAPER NAME BADGES; PRINTED CERTIFICATES; PRINTED MATERIALS, NAMELY, PRESS RELEASES FEATURING NEWS ABOUT PROGRAMS FEATURING EDUCATIONAL AND MOTIVATIONAL SPEAKERS; STICKERS.

FIRST USE 3-1-2007; IN COMMERCE 3-1-2007.

INT. CL. 41/U.S. CLS. 100, 101 AND 107

FOR EDUCATIONAL AND ENTERTAINMENT SERVICES, NAMELY, PROVIDING MOTIVATIONAL AND EDUCATIONAL SPEAKERS; EDUCATIONAL SERVICES, NAMELY, CONDUCTING PROGRAMS IN THE FIELD OF LAW, DEMOCRACY, HUMAN RIGHTS, CRIME PREVENTION, DISPUTE RESOLUTION, COMMUNITY LEADERSHIP, AND CITIZENSHIP AND DISTRIBUTION OF COURSE MATERIAL IN CONNECTION THEREWITH; EDUCATIONAL SERVICES, NAMELY, CONDUCTING TRAINING PROGRAMS IN THE FIELD OF ORGANIZING, CONDUCTING, AND EVALUATING PROGRAMS FEATURING EDUCATIONAL AND MOTIVATIONAL SPEAKERS AND DISTRIBUTION OF TRAINING MATERIAL IN CONNECTION THEREWITH.
FIRST USE 12-12-2006; IN COMMERCE 12-12-2006.

ELEMENTS CORRECTED
GOODS/SERVICES

3,863,007. REG. 10-19-2010. BLINKMIND, INC. (DELAWARE CORPORATION) 2027 BRIARCHESTER DRIVE, KATY, TX, 77450, SN 77-869,974. FILED 11-11-2009. PRINCIPAL REGISTER.



THE MARK CONSISTS OF THE STYLIZED WORDS "BLINKMIND".

INT. CL. 38/U.S. CLS. 100, 101 AND 104

FOR TELECOMMUNICATION SERVICES, NAMELY, TRANSMISSION OF VOICE, VIDEO, DATA AND GRAPHICS OVER A DISTANCE *FOR THE PURPOSES OF PERSON-TO-PERSON VIDEO CALLS, VIDEO CONFERENCING AND FOR RECORDING, STORING AND REPLAYING VIDEO*.

FIRST USE 6-17-2009; IN COMMERCE 6-17-2009.

ELEMENTS AMENDED
GOODS/SERVICES

3,862,053. REG. 10-12-2010. NP OPCO LLC (NEVADA LIMITED LIABILITY COMPANY) 1505 SOUTH PAVILION CENTER DRIVE, LAS VEGAS, NV, 89135, SN 77-895,799. FILED 12-17-2009. PRINCIPAL REGISTER.

3,875,818. REG. 11-16-2010. BLINKMIND, INC. (DELAWARE CORPORATION) 2027 BRIARCHESTER DRIVE, KATY, TX, 77450, SN 77-869,950. FILED 11-11-2009. PRINCIPAL REGISTER.



THE MARK CONSISTS OF THE WORD "BLINKMIND" TO THE RIGHT OF A SQUARE WITH CURVED CORNERS THAT IS DIVIDED BY A CURVED LINE.

INT. CL. 38/U.S. CLS. 100, 101 AND 104

FOR TELECOMMUNICATION SERVICES, NAMELY, TRANSMISSION OF VOICE, VIDEO, DATA AND GRAPHICS OVER A DISTANCE *FOR THE PURPOSES OF PERSON-TO-PERSON VIDEO CALLS, VIDEO CONFERENCING AND FOR RECORDING, STORING AND REPLAYING VIDEO CALLS AND VIDEO CONFERENCES*.

FIRST USE 6-17-2009; IN COMMERCE 6-17-2009.

ELEMENTS AMENDED
GOODS/SERVICES

NO CLAIM IS MADE TO THE EXCLUSIVE RIGHT TO USE "SALOON" AND "DANCE HALL", APART FROM THE MARK AS SHOWN.

THE COLOR(S) WHITE, BLACK AND RED IS/ARE CLAIMED AS A FEATURE OF THE MARK.

THE MARK CONSISTS OF THE WHITE STYLIZED WORD "REVOLVER" OVER THE WHITE STYLIZED WORDS "SALOON DANCE HALL" WHERE THE WORDS "SALOON" AND "DANCE" ARE SEPARATED BY A WHITE BULLET POINT ALL OF WHICH IS SUPERIMPOSED OVER A RED WOOD-GRAIN PATTERN WHICH IS SUPERIMPOSED OVER A RED DRAWING OF A GUN MUZZLE ALL OF WHICH IS FEATURED AGAINST A BLACK BACKGROUND.

INT. CL. 43/U.S. CLS. 100 AND 101

FOR BAR SERVICES.

FIRST USE 2-5-2010; IN COMMERCE 2-5-2010.

ELEMENTS CORRECTED
GOODS/SERVICES

3,876,433. REG. 11-16-2010. YKK CORPORATION (JAPAN CORPORATION) 1, KANDA IZUMI-CHO, CHIYODA-KU., TOKYO 101-8642, JAPAN., SN 79-076,010. FILED 9-1-2009. PRINCIPAL REGISTER.



PRIORITY DATE OF 8-10-2009 IS CLAIMED.

OWNER OF INTERNATIONAL REGISTRATION 1021330 DATED 9-1-2009, EXPIRES 9-1-2019.

THE MARK CONSISTS OF THE WORDS "SOFLEX" WITH THE TOP OF THE "S" DISRUPTING AND EXTENDING THROUGH THE "O" AND "F" TO UNDERLINE THE "LEX".

INT. CL. 26/U.S. CLS. 37, 39, 40, 42 AND 50
FOR SLIDE FASTENERS; HOOK AND LOOP FASTENING TAPES; ADJUSTABLE FASTENERS; RAIL FASTENERS; SNAP BUTTONS; BUTTONS; HOOKS AND EYES; HOOKS [; EYELETS FOR CLOTHING; EYELETS FOR SHOES AND BOOTS].

FIRST USE ; IN COMMERCE .

ELEMENTS CORRECTED
GOODS/SERVICES

NO CLAIM IS MADE TO THE EXCLUSIVE RIGHT TO USE "COLOR", APART FROM THE MARK AS SHOWN.
INT. CL. 3/U.S. CLS. 1, 4, 6, 50, 51 AND 52

FOR COSMETICS; LIP GLOSS; LIPSTICK; LIP BALM; LIP LINER; EYESHADOW; EYELINER; EYE CREAM; EYE MAKE-UP; NAIL POLISH; HAND CREAM; SKIN MOISTURIZER; MASCARA; SKIN BRONZING CREAMS; BODY POWDER; EYEBROW PENCILS; NON-MEDICATED FOOT CREAM.

FIRST USE 6-20-2009; IN COMMERCE 6-20-2009.

ELEMENTS CORRECTED
OWNER NAME
ENTITY

3,879,266. REG. 11-23-2010. SAM "BELEAF" (MONACO SOCIÉTÉ ANONYME MONÉGASQUE) 38 BOULEVARD DES MOULINS, MC-98000 MONACO, MONACO., SN 79-075,845. FILED 8-27-2009. PRINCIPAL REGISTER.



PRIORITY DATE OF 3-27-2009 IS CLAIMED.
OWNER OF INTERNATIONAL REGISTRATION 1020822 DATED 8-27-2009, EXPIRES 8-27-2019.

THE MARK CONSISTS OF THE STYLIZED WORDING "BE LEAF" AND A TILTED CIRCLE DESIGN, WHICH HAS SEVERAL HORIZONTAL LINES AND ONE CENTERED VERTICAL LINE AND IS BEHIND THE TERM "BE" IN THE MARK.

INT. CL. 19/U.S. CLS. 1, 12, 33 AND 50

FOR NON-METAL BUILDING MATERIALS, NAMELY, NON-METAL DOOR PANELS; NON-METALLIC RIGID PIPES FOR BUILDING; ASPHALT, PITCH AND BITUMEN; NON-METALLIC TRANSPORTABLE BUILDINGS; STONE MONUMENTS.

INT. CL. 20/U.S. CLS. 2, 13, 22, 25, 32 AND 50

FOR FURNITURE, MIRRORS, PICTURE FRAMES; PICTURE FRAMES OF WOOD, CORK, REED, CANE, WICKER, HORN, BONE, IVORY, WHALEBONE, SHELL, AMBER, MOTHER-OF-PEARL, MEERSCHAUM, AND SUBSTITUTES FOR ALL THESE MATERIALS; PICTURE FRAMES OF PLASTICS.

ELEMENTS CORRECTED
CITIZENSHIP
[GOODS/SERVICES]
[INTERNATIONAL CLASS(ES)]

3,880,759. REG. 11-23-2010. PACIFIC SALES UK LIMITED (UNITED KINGDOM PRIVATE LIMITED COMPANY) VALE ROYAL HOUSE VALE ROYAL DRIVE, WHITE-GATE, CHESHIRE, UNITED KINGDOM, CW82BA, SN 77-713,866. FILED 4-14-2009. PRINCIPAL REGISTER.

COLOR FANTASY

THE MARK CONSISTS OF STANDARD CHARACTERS WITHOUT CLAIM TO ANY PARTICULAR FONT, STYLE, SIZE, OR COLOR.

3,899,386. REG. 1-4-2011. COMPUMEDICS LIMITED (AUSTRALIA CORPORATION) 30-40 FLOCKHART STREET, ABBOTSFORD VIC 3067, AUSTRALIA, 3067, SN 79-077,949. FILED 12-9-2009. PRINCIPAL REGISTER.

GRAEL

THE MARK CONSISTS OF STANDARD CHARACTERS WITHOUT CLAIM TO ANY PARTICULAR FONT, STYLE, SIZE, OR COLOR.

PRIORITY DATE OF 7-9-2009 IS CLAIMED.
OWNER OF INTERNATIONAL REGISTRATION 1026532 DATED 12-9-2009, EXPIRES 12-9-2019.

INT. CL. 10/U.S. CLS. 26, 39 AND 44

FOR ELECTRONIC APPARATUS FOR MEDICAL USE WITH COMPUTERS, NAMELY, ELECTROENCEPHALOGRAPHY APPARATUS, ELECTROMYOGRAPHY APPARATUS, ELECTRO-OCULOGRAPHY APPARATUS, PLETHYSMOGRAPHY APPARATUS, ELECTRONIC BLOOD OXYGEN SATURATION APPARATUS, ELECTRONIC BLOOD PRESSURE APPARATUS, ELECTROCARDIOGRAPHY APPARATUS; APPARATUS FOR MEDICAL DIAGNOSTIC PURPOSES, NAMELY, ELECTROENCEPHALOGRAPHY MEDICAL APPARATUS, ELECTROMYOGRAPHY MEDICAL APPARATUS, ELECTROCARDIOGRAPHY MEDICAL APPARATUS, ELECTRO-OCULOGRAPHY MEDICAL APPARATUS, BLOOD PRESSURE MEDICAL APPARATUS, BODY TEMPERATURE MEASUREMENT APPARATUS, BLOOD OXYGEN MEASUREMENT APPARATUS; ELECTRO-MEDICAL DIAGNOSTIC INSTRUMENTS FOR SLEEP-STAGING; MEDICAL DIAGNOSTIC APPARATUS FOR SLEEP-STAGING; APPARATUS FOR ANALYSING BRAIN WAVE FREQUENCIES FOR MEDICAL USE; CONSUMABLE ELECTRODES FOR MEDICAL USE; ELECTRODES FOR MEDICAL PURPOSES; ELECTRODES FOR MEDICAL USE; ELECTRODES FOR PICKING UP BIOLOGICAL PARAMETERS FOR MEDICAL USE; ELECTRODES FOR PICKING UP ELECTROPHYSIOLOGICAL PARAMETERS FOR MEDICAL USE; ELECTRODES FOR USE WITH MEDICAL APPARATUS; ELECTROPHYSIOLOGY ELECTRODES FOR MEDICAL USE; MEDICAL ELECTRODES; OXYGEN ELECTRODES FOR MEDICAL USE; OXYGEN SENSORS FOR MEDICAL USE; PRECISION SENSORS MEASURING SMALL ELECTRICAL CURRENTS AND VOLTAGES FOR PHYSIOLOGICAL MEASUREMENTS OF THE BODY FOR MEDICAL USE; SENSORS FOR MEASURING PHYSIOLOGICAL PARAMETERS OF THE HUMAN BODY FOR MEDICAL USE; SENSORS MEASURING BODY POSITION FOR MEDICAL USE; TEMPERATURE SENSORS FOR MEDICAL USE .

FIRST USE ; IN COMMERCE .

ELEMENTS CORRECTED
[GOODS/SERVICES]
[INTERNATIONAL CLASS(ES)]

3,902,480. REG. 1-11-2011. NFR INVESTMENTS PTY LIMITED (AUSTRALIA COMPANY) UNIT 6, 3 CENTRAL AVENUE, THORNLEIGH, AUSTRALIA., SN 77-581,951. FILED 9-30-2008. PRINCIPAL REGISTER.

CREATABLES

THE MARK CONSISTS OF STANDARD CHARACTERS WITHOUT CLAIM TO ANY PARTICULAR FONT, STYLE, SIZE, OR COLOR.

PRIORITY CLAIMED UNDER SEC. 44(D) ON AUSTRALIA APPLICATION NO. 1234064, FILED 4-9-2008, REG. NO. 1234064, DATED 4-9-2008.

INT. CL. 9/U.S. CLS. 21, 23, 26, 36 AND 38

FOR APPARATUS FOR RECORDING, TRANSMISSION OR REPRODUCTION OF SOUND OR IMAGES; RECORDING DISCS, NAMELY, BLANK RECORDABLE DISCS, BLANK DISKETTES, BLANK DVDS; AUTOMATIC VENDING MACHINES AND MECHANISMS FOR COIN-OPERATED APPARATUS; CASH REGISTERS, CALCULATING MACHINES, DATA PROCESSING EQUIPMENT AND COMPUTERS; GAMES SOFTWARE; DOWNLOADABLE MUSIC AND VIDEOS, NAMELY, DIGITAL MUSIC DOWNLOADABLE FROM THE INTERNET AND DOWNLOADABLE VIDEO RECORDINGS FEATURING FOOD; DOWNLOADABLE NEWSLETTERS IN THE FIELD OF FOOD.

FIRST USE ; IN COMMERCE .

INT. CL. 25/U.S. CLS. 22 AND 39

FOR CLOTHING, NAMELY, T-SHIRTS; UNDERWEAR; DRESSES; SKIRTS; TROUSERS; JEANS; SHORTS; CULOTTES; BLOUSES; SHIRTS; POLO SHIRTS; RUGBY SHIRTS; JUMPERS; CARDIGANS; PULLOVERS; FLEECES, NAMELY, FLEECE PULLOVERS; SWEATERS; COATS; RAINCOATS; MACKINTOSHES; OVERCOATS; JACKETS; SWIMWEAR; SWIMMING COSTUMES; BIKINIS; DRESSING GOWNS; NIGHT ATTIRE, NAMELY, NIGHT WEAR, NIGHT GOWNS, NIGHT SHIRTS, NIGHTIES; PYJAMAS; BATH ROBES; NIGHT DRESSES; FOOTWEAR; HEADGEAR, NAMELY, HATS, CAPS, BERETS.

FIRST USE ; IN COMMERCE .

INT. CL. 28/U.S. CLS. 22, 23, 38 AND 50

FOR GAMES AND PLAYTHINGS, NAMELY, ACTION SKILL GAMES, BOARD GAMES, CARD GAMES, MANIPULATIVE GAMES, PINBALL GAMES, DOLLS, DOLL CLOTHES AND DOLL ACCESSORIES; PARLOR GAMES, NAMELY, BILLIARDS IN THE NATURE OF BILLIARD GAME PLAYING EQUIPMENT, BILLIARD TABLES, BILLIARD BALLS; DOLL FURNITURE; MECHANICAL TOYS, PLUSH TOYS, ACTION FIGURES NOT INCLUDING CREATIVE ART TOYS MADE OF WAX-IMPREGNATED YARN STRANDS FOR DRAWING, TRACING, SPELLING, AND LEARNING; GYMNAS TIC AND SPORTING ARTICLES, NAMELY, BALANCE BEAMS, HORIZONTAL BARS, PERSONAL EXERCISE MATS, RINGS IN THE NATURE OF RING GAMES, EXERCISE BALLS, RHYTHMIC GYMNAS TIC HOOPS, RIBBONS SPECIFICALLY DESIGNED FOR USE IN RHYTHMIC GYMNAS TIC, ROPES IN THE NATURE OF JUMP ROPES, SKIPPING ROPES, TRAMPOLINES AND GYMNAS TIC TRAINING STOOLS, SKATEBOARDS, IN-LINE SKATES, SOCCER BALLS, BASKETBALLS, BEACH BALLS, TENNIS RACKETS, TABLE TENNIS RACKETS, BEACH RACKETS, NAMELY, TENNIS AND BADMINTON RACKETS, SKIS; DECORATIONS FOR CHRISTMAS TREES.

FIRST USE ; IN COMMERCE .

INT. CL. 29/U.S. CL. 46

FOR [SNACK FOODS, NAMELY, FRUIT BASED SNACK FOODS, NUT BASED SNACK FOODS, SOY BASED SNACK FOODS;] PREPARED MEALS CONSISTING PRIMARILY OF MEAT, FISH, POULTRY OR VEGETABLES.

FIRST USE ; IN COMMERCE .

INT. CL. 30/U.S. CL. 46

FOR [SNACK FOODS, NAMELY, CEREAL BASED SNACK FOODS, GRAIN BASED SNACK FOODS, RICE BASED SNACK FOODS, CORN BASED SNACK FOODS, AND WHEAT BASED SNACK FOODS; ICE CREAM AND ICES; BAKED GOODS, NAMELY, BREAD, PASTRY AND BISCUITS; PREPARATIONS MADE FROM CEREALS, NAMELY, BREAKFAST CEREALS, PROCESSED CEREALS, CEREAL DERIVED FOOD BARS;] SAUCES; COFFEE, TEA, COCOA; PREPARED MEALS CONSISTING PRIMARILY OF PASTA OR RICE.

FIRST USE ; IN COMMERCE .

INT. CL. 35/U.S. CLS. 100, 101 AND 102

FOR RETAILING AND WHOLESALING SERVICES, NAMELY, RETAIL AND WHOLESALE STORE SERVICES FEATURING ELECTRICAL AND ELECTRONIC PRODUCTS, COMPUTER SOFTWARE, MUSIC, VIDEOS, PUBLICATIONS, CLOTHING, FOOTWEAR, HEADGEAR, GAMES, PLAYTHINGS AND TOYS, NAMELY, ACTION SKILL GAMES, BOARD GAMES, CARD GAMES, MANIPULATIVE GAMES, PINBALL GAMES, DOLLS, DOLL CLOTHES AND DOLL ACCESSORIES, PARLOR GAMES, NAMELY, WORD GAMES AND BILLIARDS, DOLL FURNITURE, MECHANICAL TOYS, PLUSH TOYS, ACTION FIGURES NOT INCLUDING CREATIVE ART TOYS MADE OF WAX-IMPREGNATED YARN STRANDS FOR DRAWING, TRACING, SPELLING, AND LEARNING, GYMNAS TIC AND SPORTING ARTICLES, [SNACK FOODS, NAMELY, CEREAL BASED SNACK FOODS, GRAIN BASED SNACK FOODS, RICE BASED SNACK FOODS, FRUIT BASED SNACK FOODS, NUT BASED SNACK FOODS, CORN BASED SNACK FOODS, WHEAT BASED SNACK FOODS, SOY BASED SNACK FOODS, ICE CREAM, BAKED GOODS, BREAKFAST FOODS, PREPARATIONS MADE FROM CEREAL,] BEVERAGES PREPARED MEALS, BAGS AND FASHION ACCESSORIES, PUBLICATIONS, EDUCATIONAL PRODUCTS [AND HEALTH FOODS]; ONLINE RETAILING AND WHOLESALING IN THE NATURE OF ONLINE RETAIL STORE SERVICES AND ONLINE WHOLESALE STORE SERVICES FEATURING ELECTRICAL AND ELECTRONIC PRODUCTS, COMPUTER SOFTWARE, MUSIC, VIDEOS, PUBLICATIONS, CLOTHING, FOOTWEAR, HEADGEAR, GAMES, PLAYTHINGS AND TOYS, NAMELY, ACTION SKILL GAMES, BOARD GAMES, CARD GAMES, MANIPULATIVE GAMES, PINBALL GAMES, DOLLS, DOLL CLOTHES AND DOLL ACCESSORIES, PARLOR GAMES, NAMELY, WORD GAMES AND BILLIARDS, DOLL FURNITURE, MECHANICAL TOYS, PLUSH TOYS, ACTION FIGURES NOT INCLUDING CREATIVE ART TOYS MADE OF WAX-IMPREGNATED YARN STRANDS FOR DRAWING, TRACING, SPELLING AND LEARNING, GYMNAS TIC AND SPORTING ARTICLES, SNACK FOODS, NAMELY, CEREAL BASED SNACK FOODS, GRAIN BASED SNACK FOODS, RICE BASED SNACK FOODS, FRUIT BASED SNACK FOODS, NUT BASED SNACK FOODS, CORN BASED SNACK FOODS, WHEAT BASED SNACK FOODS, SOY BASED SNACK FOODS, ICE CREAM, BAKED GOODS, BREAKFAST FOODS, PREPARATIONS MADE FROM CEREAL, BEVERAGES PREPARED MEALS, BAGS AND FASHION ACCESSORIES, EDUCATIONAL PRODUCTS AND HEALTH FOODS; BUSINESS MANAGEMENT; BUSINESS ADMINISTRATION; PROVIDING BUSINESS MARKETING INFORMATION; PROVIDING OFFICE FUNCTIONS; BUSINESS MARKETING AND CONSULTATION SERVICES; MARKET RESEARCH AND ANALYSIS SERVICES; PRODUCT MERCHANDISING AND DISPLAY SERVICES, NAMELY, BUSINESS MERCHANDISING DISPLAY SERVICES, WINDOW DISPLAY ARRANGEMENT SERVICES, PROMOTIONAL MERCHANDISING SERVICES IN THE NATURE OF PRODUCT MERCHANDISING FOR PROMOTIONAL PURPOSES, BUSINESS MERCHANDISING DISPLAY SERVICES, PREPARING PROMOTIONAL AND MERCHANDISING MATERIAL FOR OTHERS; CONDUCTING MARKETING STUDIES.

FIRST USE ; IN COMMERCE .

ELEMENTS AMENDED
GOODS/SERVICES

3,909,359. REG. 1-18-2011. AXIAL BIOTECH, INC. (DELAWARE CORPORATION) 2749 EAST PARLEY'S WAY, SUITE 200, SALT LAKE CITY, UT, 84109, SN 78-683,028. FILED 8-1-2005. PRINCIPAL REGISTER.

3,942,547. REG. 4-12-2011. GLOBAL HOTELS & RESORTS IP BV (NETHERLANDS ANTILLES CORPORATION) PIETERMAAI 15, CURACAO, NETHERLANDS ANTILLES., SN 77-502,836. FILED 6-19-2008. PRINCIPAL REGISTER.

AXIAL BIOTECH

THE MARK CONSISTS OF STANDARD CHARACTERS WITHOUT CLAIM TO ANY PARTICULAR FONT, STYLE, SIZE, OR COLOR.

NO CLAIM IS MADE TO THE EXCLUSIVE RIGHT TO USE "BIOTECH", APART FROM THE MARK AS SHOWN.

INT. CL. 16/U.S. CLS. 2, 5, 22, 23, 29, 37, 38 AND 50

FOR PRINTED MATERIALS, NAMELY, PRINTED TEACHING MATERIALS IN THE FIELD OF SPINE DISORDERS, PRESS RELEASES FEATURING SPINE DISORDERS, BOOKS FEATURING SPINE DISORDERS, BROCHURES AND PAMPHLETS FEATURING SPINE DISORDERS, SCHOLARLY ARTICLES IN THE FIELD OF SPINE DISORDERS, RESEARCH STUDIES IN THE FIELD OF SPINE DISORDERS; NOTEPADS; CALENDARS; PAPER MATERIALS, NAMELY, BINDERS, NOTEBOOKS, FOLDERS, PAPER BOXES, PAPER BAGS AND PAPER CONTAINERS, BLANK WRITING JOURNALS; WRITING IMPLEMENTS AND STATIONERY GOODS.

FIRST USE 2-24-2004; IN COMMERCE 2-24-2004.

INT. CL. 20/U.S. CLS. 2, 13, 22, 25, 32 AND 50

FOR NON-METAL IDENTIFICATION AND CARD BADGE HOLDERS.

FIRST USE 2-24-2004; IN COMMERCE 2-24-2004.

ELEMENTS CORRECTED
CITIZENSHIP

3,921,142. REG. 2-15-2011. AXIAL BIOTECH, INC. (DELAWARE CORPORATION) 2749 EAST PARLEY'S WAY, SUITE 200, SALT LAKE CITY, UT, 84109, SN 78-683,030. FILED 8-1-2005. PRINCIPAL REGISTER.

AXIAL BIOTECH

THE MARK CONSISTS OF STANDARD CHARACTERS WITHOUT CLAIM TO ANY PARTICULAR FONT, STYLE, SIZE, OR COLOR.

INT. CL. 25/U.S. CLS. 22 AND 39

FOR CLOTHING AND SPORTSWEAR, NAMELY, JACKETS, SHIRTS, T-SHIRTS, SWEATSHIRTS, SPORTS SHIRTS, VESTS, SWEATERS, NECKBANDS, HEADWEAR, NAMELY, CAPS AND HATS, SPORT CAPS, FLEECE GOODS, NAMELY, FLEECE JACKETS.

FIRST USE 8-1-2005; IN COMMERCE 8-1-2005.

ELEMENTS CORRECTED
CITIZENSHIP

SPIN

THE MARK CONSISTS OF STANDARD CHARACTERS WITHOUT CLAIM TO ANY PARTICULAR FONT, STYLE, SIZE, OR COLOR.

PRIORITY CLAIMED UNDER SEC. 44(D) ON ERP N CMNTY TM OFC APPLICATION NO. 6793152, FILED 3-31-2008, REG. NO. 006793152, DATED 4-11-2008.

INT. CL. 35/U.S. CLS. 100, 101 AND 102

FOR RENTAL OF ROOMS FOR HOLDING BUSINESS FUNCTIONS, CONFERENCES, SEMINARS AND MEETINGS; PROVIDING FACILITIES FOR BUSINESS MEETINGS; CONSUMER LOYALTY SERVICES FOR COMMERCIAL, PROMOTIONAL, AND/OR ADVERTISING PURPOSES, NAMELY, ADMINISTRATION OF FREQUENT FLYER PROGRAM THAT ALLOWS MEMBERS TO REDEEM MILES FOR POINTS OR AWARDS OFFERED BY OTHER LOYALTY PROGRAMS.

FIRST USE ; IN COMMERCE .

INT. CL. 36/U.S. CLS. 100, 101 AND 102

FOR FINANCIAL AFFAIRS, NAMELY, FINANCIAL PLANNING, FINANCIAL DUE DILIGENCE, AND FINANCIAL MANAGEMENT; MONETARY AFFAIRS, NAMELY, ACQUISITION AND TRANSFER OF MONETARY CLAIMS AND MONETARY EXCHANGE SERVICES; REAL ESTATE AFFAIRS, NAMELY, APPRAISAL OF REAL ESTATE, REAL ESTATE LISTING, AND REAL ESTATE BROKERAGE; INFORMATION, CONSULTANCY AND ADVISORY SERVICES RELATING TO THE AFORESAID SERVICES.

INT. CL. 43/U.S. CLS. 100 AND 101

FOR HOTEL SERVICES, RESORT HOTEL AND LODGING SERVICES, MOTEL SERVICES, PROVIDING TEMPORARY ACCOMMODATION, HOTEL RESERVATION SERVICES; TRAVEL AGENCY SERVICES FOR THE RESERVATION OF ACCOMMODATION; TEMPORARY ACCOMMODATION SERVICES, NAMELY, ARRANGING TEMPORARY HOUSING ACCOMMODATION; HOLIDAY INFORMATION AND PLANNING RELATING TO TEMPORARY ACCOMMODATION; CATERING SERVICES RESTRICTED TO THE SAME PREMISES AS THE HOTEL SERVICES; BANQUETING SERVICES RESTRICTED TO THE SAME PREMISES AS THE HOTEL SERVICES; PROVISION OF CONFERENCE FACILITIES; PROVIDING BANQUET AND SOCIAL FUNCTION FACILITIES FOR SPECIAL OCCASIONS * RESTRICTED TO THE SAME PREMISES AS THE HOTEL SERVICES *; AND PROVIDING INFORMATION IN THE FIELD OF HOTELS AND PROVIDING TEMPORARY ACCOMMODATIONS.

FIRST USE ; IN COMMERCE .

INT. CL. 45/U.S. CLS. 100 AND 101

FOR CONCIERGE SERVICES, HOTEL CONCIERGE SERVICES.

ELEMENTS AMENDED
GOODS/SERVICES

3,943,348. REG. 4-12-2011. LEHAN, LISBETH (NORWAY INDIVIDUAL) 4450 ARAPAHOE AVE, #100, BOULDER, CO, 80303, SN 85-043,218. FILED 5-19-2010. PRINCIPAL REGISTER.

lillébaby

THE MARK CONSISTS OF STANDARD CHARACTERS WITHOUT CLAIM TO ANY PARTICULAR FONT, STYLE, SIZE, OR COLOR.

INT. CL. 18/U.S. CLS. 1, 2, 3, 22 AND 41
FOR BABY CARRIERS WORN ON THE BODY; DIAPER BAGS.
FIRST USE 7-1-2002; IN COMMERCE 7-1-2002.

ELEMENTS CORRECTED
OWNER NAME

3,947,081. REG. 4-19-2011. HAIN GOURMET, INC. (DELAWARE CORPORATION) SUITE 250, 58 SOUTH SERVICE ROAD, MELVILLE, NY, 11747, SN 85-030,147. FILED 5-4-2010. PRINCIPAL REGISTER.

GARDEN VEGGIE STRAWS

THE MARK CONSISTS OF STANDARD CHARACTERS WITHOUT CLAIM TO ANY PARTICULAR FONT, STYLE, SIZE, OR COLOR.

AS TO "VEGGIE STRAWS".
INT. CL. 29/U.S. CL. 46
FOR VEGETABLE-BASED SNACK FOODS.
FIRST USE 10-1-2004; IN COMMERCE 10-1-2004.

ELEMENTS CORRECTED
OWNER NAME
CITIZENSHIP
ENTITY
OWNER ADDRESS

3,950,008. REG. 4-26-2011. SCHOTT AG (FED REP GERMANY JOINT STOCK COMPANY) HATTENBERGSTRASSE 10, 55122 MAINZ, FED REP GERMANY., SN 79-072,425. FILED 7-1-2009. PRINCIPAL REGISTER.

NOVOLAY

THE MARK CONSISTS OF STANDARD CHARACTERS WITHOUT CLAIM TO ANY PARTICULAR FONT, STYLE, SIZE, OR COLOR.

PRIORITY DATE OF 1-14-2009 IS CLAIMED.
OWNER OF INTERNATIONAL REGISTRATION 1011900 DATED 7-1-2009, EXPIRES 7-1-2019.
OWNER OF U.S. REG. NO. 3,318,446.
INT. CL. 12/U.S. CLS. 19, 21, 23, 31, 35 AND 44

FOR STRUCTURAL PARTS FOR LAND VEHICLES, NAMELY, FOR CARS, BUSES, TRUCKS; STRUCTURAL PARTS FOR APPARATUS FOR LOCOMOTION BY LAND, AIR OR WATER, NAMELY, FOR MILITARY VEHICLES, TANKS, AIRPLANES, HELICOPTERS, MILITARY AIRCRAFT, BOATS, SHIPS, SUBMARINES, AND AMPHIBIOUS VEHICLES.

FIRST USE ; IN COMMERCE .
INT. CL. 19/U.S. CLS. 1, 12, 33 AND 50
FOR NON-METALLIC BUILDING MATERIALS, NAMELY, BUILDING GLASS OR GLASS-CERAMIC; NON-METALLIC TRANSPORTABLE BUILDINGS AND STRUCTURAL PARTS THEREFORE.
FIRST USE ; IN COMMERCE .
INT. CL. 21/U.S. CLS. 2, 13, 23, 29, 30, 33, 40 AND 50
FOR UNWORKED OR SEMI-WORKED GLASS, EXCEPT GLASS USED IN BUILDING.
FIRST USE ; IN COMMERCE .

ELEMENTS CORRECTED
GOODS/SERVICES

3,951,879. REG. 4-26-2011. ABERCROMBIE & FITCH TRADING CO. (OHIO CORPORATION) ATTN: JACOB KRAMER, 6301 FITCH PATH, NEW ALBANY, OH, 43054, SN 77-896,032. FILED 12-17-2009. PRINCIPAL REGISTER.



OWNER OF U.S. REG. NOS. 2,626,917 AND 3,135,750.
THE MARK CONSISTS OF TWO CURVED DOUBLE LINES, INTERSECTING TWICE, FORMING AN EYE SHAPE IN THE CENTER.
INT. CL. 25/U.S. CLS. 22 AND 39
FOR DENIM BOTTOMS, NAMELY, JEANS, SKIRTS, SHORTS, PANTS; DENIM JACKETS; PANTS.
FIRST USE 2-1-2001; IN COMMERCE 2-1-2001.

ELEMENTS CORRECTED
DATE OF FIRST USE

3,960,650. REG. 5-17-2011. PROTEAN POWER PTY LTD (AUSTRALIA COMPANY) 6 ORD STREET, WEST PERTH WA 6005, AUSTRALIA., SN 79-071,005. FILED 5-25-2009. PRINCIPAL REGISTER.

PROTEAN

THE MARK CONSISTS OF STANDARD CHARACTERS WITHOUT CLAIM TO ANY PARTICULAR FONT, STYLE, SIZE, OR COLOR.

PRIORITY DATE OF 11-27-2008 IS CLAIMED.
OWNER OF INTERNATIONAL REGISTRATION 1007960 DATED 5-25-2009, EXPIRES 5-25-2019.
INT. CL. 7/U.S. CLS. 13, 19, 21, 23, 31, 34 AND 35

FOR INSTALLATIONS FOR THE PRODUCTION OF POWER FROM WAVE MOTION; POWER GENERATION APPARATUS, NAMELY, WAVE ENERGY CONVERTERS; ELECTRIC POWER SUPPLIES; APPARATUS FOR THE GENERATION OF ELECTRICITY; POWER TRANSMISSION MECHANISMS, NAMELY, TURBINES FOR POWER GENERATION; WIND TURBINES; TURBINE ELECTRICITY GENERATING MACHINES; AND REPLACEMENT PARTS, FITTINGS AND ACCESSORIES IN THIS CLASS FOR ALL OF THE AFOREMENTIONED GOODS.

FIRST USE ; IN COMMERCE .
INT. CL. 37/U.S. CLS. 100, 103 AND 106

FOR BUILDING CONSTRUCTION; INSTALLATION, REPAIR AND MAINTENANCE OF ENERGY CONVERSION APPARATUS AND POWER PLANTS; INSTALLATION, REPAIR AND MAINTENANCE OF WAVE ENERGY CONVERSION APPARATUS AND WAVE ENERGY POWER PLANTS; AND INFORMATION AND ADVISORY SERVICES IN RELATION TO THE CONSTRUCTION, REPAIR, MAINTENANCE AND INSTALLATION OF ENERGY CONVERSION APPARATUS, POWER PLANTS, WAVE ENERGY CONVERSION APPARATUS AND WAVE ENERGY POWER PLANTS.

FIRST USE ; IN COMMERCE .
INT. CL. 39/U.S. CLS. 100 AND 105

FOR DISTRIBUTION OF ENERGY; INFORMATION AND ADVISORY SERVICES IN RELATION TO THE DISTRIBUTION OF ENERGY; AND INFORMATION AND ADVISORY SERVICES IN RELATION TO THE DISTRIBUTION OF POWER FROM WAVE MOTION AND FROM INSTALLATIONS FOR THE PRODUCTION OF POWER FROM WAVE MOTION.

FIRST USE ; IN COMMERCE .
INT. CL. 40/U.S. CLS. 100, 103 AND 106

FOR PRODUCTION OF ENERGY; GENERATION OF ELECTRICITY; GENERATION OF ENERGY FROM WAVE MOTION, WIND AND THE SUN; CUSTOM FABRICATION OF METAL HARDWARE, AND ENGINEERING PRODUCTS; AND INFORMATION AND ADVISORY SERVICES IN RELATION TO THE PRODUCTION OF ENERGY AND THE GENERATION OF ENERGY FROM WAVE MOTION; * CONSULTANCY SERVICES IN RELATION TO ENERGY GENERATION, AND THE PRODUCTION OF ENERGY FROM WAVE MOTION, THE WIND AND THE SUN *.

FIRST USE ; IN COMMERCE .
INT. CL. 42/U.S. CLS. 100 AND 101

FOR [CONSULTANCY SERVICES IN RELATION TO ENERGY GENERATION, AND THE PRODUCTION OF ENERGY FROM WAVE MOTION, THE WIND AND THE SUN;] INDUSTRIAL DESIGN SERVICES; ENERGY AUDITING; MATERIAL TESTING; MECHANICAL RESEARCH; ENGINEERING SERVICES; ACCREDITATION SERVICES, NAMELY, SETTING AND PROVIDING STANDARDS MONITORING IN THE USE OF ENERGY; RESEARCH IN THE FIELD OF ENVIRONMENTAL PROTECTION; AND INFORMATION AND ADVISORY SERVICES IN RELATION TO ENERGY GENERATION, AND THE PRODUCTION OF ENERGY FROM WAVE MOTION, WIND AND THE SUN.

FIRST USE ; IN COMMERCE .

ELEMENTS CORRECTED
GOODS/SERVICES

3,960,806. REG. 5-17-2011. WERNER CHRIST GMBH (FED REP. GERMANY LIMITED LIABILITY COMPANY) SCHÖNECKER STRABE 40, 56283 GONDELSHAUSEN, FED REP GERMANY., SN 79-086,350. FILED 6-5-2010. PRINCIPAL REGISTER.

BABYSWEET

THE MARK CONSISTS OF STANDARD CHARACTERS WITHOUT CLAIM TO ANY PARTICULAR FONT, STYLE, SIZE, OR COLOR.

OWNER OF INTERNATIONAL REGISTRATION 0723622 DATED 9-7-1999, EXPIRES 9-7-2019.
INT. CL. 12/U.S. CLS. 19, 21, 23, 31, 35 AND 44

FOR CAR SEAT-COVERS, WHEELCHAIR CUSHIONS.
INT. CL. 18/U.S. CLS. 1, 2, 3, 22 AND 41

FOR ANIMAL SKINS AND HIDES, ESPECIALLY LAMBSKINS, AND GOODS MADE THEREOF, NAMELY, SADDLE CLOTHS, CAPARISONS FOR HORSES, SADDLE SEAT-COVERS, SADDLE CUSHIONS, SADDLE GIRTH COVERS, HORSE HALTER-STRAP COVERS.

FIRST USE ; IN COMMERCE .
INT. CL. 20/U.S. CLS. 2, 13, 22, 25, 32 AND 50

FOR SEAT CUSHIONS; SEAT COVERS, NAMELY, FITTED FABRIC AND NON-FABRIC COVERS FOR CHAIRS, ARMCHAIRS, BENCHES AND SOFAS; * BOLSTERS *.

FIRST USE ; IN COMMERCE .
INT. CL. 24/U.S. CLS. 42 AND 50

FOR BED INLAYS, NAMELY, MATTRESS COVERS AND MATTRESS PADS [; BOLSTERS].

FIRST USE ; IN COMMERCE .
INT. CL. 25/U.S. CLS. 22 AND 39

FOR ELBOW, KNEE, AND HEEL PROTECTORS, NAMELY, ELBOW, KNEE, AND HEEL WARMERS; SHOES; BOOTS; AND FOOT MUFFS.

FIRST USE ; IN COMMERCE .

ELEMENTS CORRECTED
GOODS/SERVICES

3,960,942. REG. 5-17-2011. ARISTOCRAT TECHNOLOGIES AUSTRALIA PTY LTD. (AUSTRALIA CORPORATION) 85 EPPING ROAD, BUILDING A, PINNACLE OFFICE PARK, NORTH RYDE, NSW, AUSTRALIA, 2113, SN 85-040,341. FILED 5-17-2010. PRINCIPAL REGISTER.

JADE GARDEN

THE MARK CONSISTS OF STANDARD CHARACTERS WITHOUT CLAIM TO ANY PARTICULAR FONT, STYLE, SIZE, OR COLOR.

OWNER OF AUSTRALIA REG. NO. 1337897, DATED 12-22-2009, EXPIRES 12-22-2019.

INT. CL. 9/U.S. CLS. 21, 23, 26, 36 AND 38

FOR ELECTRONIC GAMING MACHINES, NAMELY, DEVICES WHICH ACCEPT A WAGER.

FIRST USE ; IN COMMERCE .

ELEMENTS CORRECTED
OWNER NAME

3,962,600. REG. 5-17-2011. BEVERLY KAYE & ASSOCIATES, INC. (PENNSYLVANIA CORPORATION), DBA CAREER SYSTEMS INTERNATIONAL, SUITE 500, 2300 STAFFORD AVENUE, SCRANTON, PA, 18505, SN 77-829,990. FILED 9-18-2009. PRINCIPAL REGISTER.

SELF POWERED CAREERS

THE MARK CONSISTS OF STANDARD CHARACTERS WITHOUT CLAIM TO ANY PARTICULAR FONT, STYLE, SIZE, OR COLOR.

NO CLAIM IS MADE TO THE EXCLUSIVE RIGHT TO USE "CAREERS", APART FROM THE MARK AS SHOWN.
INT. CL. 16/U.S. CLS. 2, 5, 22, 23, 29, 37, 38 AND 50

FOR PRINTED EDUCATIONAL MATERIALS IN THE FIELD OF CAREER DEVELOPMENT, ASSESSMENT, PLANNING OR IMPROVEMENT.

FIRST USE 6-30-2010; IN COMMERCE 6-30-2010.
INT. CL. 35/U.S. CLS. 100, 101 AND 102

FOR PROVIDING ONLINE CONTENT FEATURING CONSULTING SERVICES IN THE FIELD OF CAREER DEVELOPMENT, ASSESSMENT, PLANNING OR IMPROVEMENT.

FIRST USE 6-30-2010; IN COMMERCE 6-30-2010.

ELEMENTS CORRECTED
DBA/AKA

3,964,390. REG. 5-24-2011. KINSHO CORPORATION (JAPAN CORPORATION) 8-1 AKASHICHO, CHUO-KU, TOKYO 104-6591, JAPAN., SN 79-066,230. FILED 2-5-2009. PRINCIPAL REGISTER.

Unimetals

PRIORITY DATE OF 11-20-2008 IS CLAIMED.
OWNER OF INTERNATIONAL REGISTRATION 0995911 DATED 2-5-2009, EXPIRES 2-5-2019.

THE MARK CONSISTS OF THE WORDING "UNIMETALS" IN A STYLIZED FONT.

INT. CL. 6/U.S. CLS. 2, 12, 13, 14, 23, 25 AND 50

FOR IRONS AND STEELS; NONFERROUS METALS AND THEIR ALLOYS; ORES OF METAL, NAMELY, ZINC ORES, ANTIMONY ORES, CHROME IRON ORES, COBALT ORES, TIN ORES, BISMUTH ORES, TUNGSTEN ORES, IRON ORES, COPPER ORES, LEAD ORES, NICKEL ORES, MANGANESE ORES, AND MOLYBDENUM ORES; METAL MATERIALS FOR BUILDING OR CONSTRUCTION, NAMELY, CHIMNEY SHAFTS, STAIR TREADS, FASTENERS FOR CASEMENT WINDOWS, GUARDRAILS, WALL LININGS, PILINGS, GRATINGS, TUNNELING MATERIALS IN THE NATURE OF CEILING SUPPORTS, FENCES, SHUTTERS, WATER-PIPES, TILES, STEEL FRAMES FOR BUILDING, SHELF BOARDS, HINGES, HANDRAILS, GABIONS OF STEEL WIRE, CEILING BOARDS, CEILING DECORATIONS, NAMELY, CEILING PANELS AND MEDALLIONS, POLES FOR ELECTRIC POWER LINES, DOOR KNOCKERS, GUTTERS, GUTTER BRACKETS, SLIDING DOOR PULLEYS OR ROLLERS, DOORS, DOOR HANDLES, PILLARS, WAINSCOTINGS, BEAMS, GRILLES IN THE NATURE OF GRATINGS, WIRE FENCES, FIRE RETARDING DOORS, FLOOR PAVING TILES, WINDOWS, WINDOW KNOBS, WINDOW FRAMES, WINDOW PULLEYS, MANHOLE COVERS, GATES, BARBED WIRES, FLOOR BOARDS, ROCKSLIDE RETENTION WIRE NETS, AND LATHS.

FIRST USE ; IN COMMERCE .

INT. CL. 35/U.S. CLS. 100, 101 AND 102

FOR DISTRIBUTORSHIP SERVICES IN THE FIELD OF BUILDING MATERIALS, NAMELY, [CHIMNEY SHAFTS,] STAIR TREADS, FASTENERS FOR CASEMENT WINDOWS, [GUARDRAILS,] WALL LININGS, PILINGS, GRATINGS, TUNNELING MATERIALS, FENCES, SHUTTERS, [WATER-PIPES,] TILES, STEEL FRAMES FOR BUILDING, SHELF BOARDS, [HINGES, HANDRAILS,] GABIONS OF STEEL WIRE, CEILING BOARDS, CEILING DECORATIONS, ELECTRIC POLES, DOOR KNOCKERS, [GUTTERS, GUTTER BRACKETS,] SLIDING DOOR PULLEY OR ROLLERS, DOORS, [DOOR HANDLES,] DOOR CLOSERS, PILLARS, WAINSCOTINGS, BEAMS, [GRILLES,] WIRE FENCES, FIRE RETARDING DOORS, FLOOR PAVINGS, WINDOWS, WINDOW KNOBS, WINDOW FRAMES, WINDOW PULLEYS, MANHOLE COVERS, GATES, BARBED WIRES, FLOOR BOARDS, LOUVER DOORS, ROCKSLIDE RETENTION WIRE NETS, AND LATHS; [DISTRIBUTORSHIP SERVICES IN THE FIELD OF IRONS AND STEELS; DISTRIBUTORSHIP SERVICES IN THE FIELD OF NONFERROUS METAL; DISTRIBUTORSHIP SERVICES IN THE FIELD OF NONFERROUS METALS IN FOIL OR POWDER FORM FOR PAINTERS, DECORATORS, PRINTERS AND ARTISTS; DISTRIBUTORSHIP SERVICES IN THE FIELD OF PRECIOUS METALS

IN FOIL OR POWDER FORM FOR PAINTERS, DECORATORS, PRINTERS AND ARTISTS; DISTRIBUTORSHIP SERVICES IN THE FIELD OF NONFERROUS METALS AND THEIR ALLOYS; DISTRIBUTORSHIP SERVICES IN THE FIELD OF PRECIOUS METALS;] DISTRIBUTORSHIP SERVICES IN THE FIELD OF NON-METALLIC MINERALS; [DISTRIBUTORSHIP SERVICES IN THE FIELD OF ORES OF METAL;] DISTRIBUTORSHIP SERVICES IN THE FIELD OF UNWROUGHT PRECIOUS STONES; DISTRIBUTORSHIP SERVICES IN THE FIELD OF RAW OR PARTLY PROCESSED MICA; DISTRIBUTORSHIP SERVICES IN THE FIELD OF NON-METALLIC MINERALS FOR BUILDING OR CONSTRUCTION; DISTRIBUTORSHIP SERVICES IN THE FIELD OF MEERSCHAUM AND AMBER.
FIRST USE ; IN COMMERCE .

ELEMENTS CORRECTED
GOODS/SERVICES

3,969,001. REG. 5-31-2011. CDS FREIGHT HOLDING LTD. (HONG KONG LIMITED CORPORATION) UNIT A, 2/F, CHT TOWER, TERMINAL 8 EAST, CONTAINER PORT ROAD SOUTH, KWAI CHUNG, N.T., HONG KONG., SN 85-009,123. FILED 4-8-2010. PRINCIPAL REGISTER.

CDS GLOBAL LOGISTICS INC.

THE MARK CONSISTS OF STANDARD CHARACTERS WITHOUT CLAIM TO ANY PARTICULAR FONT, STYLE, SIZE, OR COLOR.

NO CLAIM IS MADE TO THE EXCLUSIVE RIGHT TO USE "GLOBAL LOGISTICS INC.", APART FROM THE MARK AS SHOWN.

INT. CL. 35/U.S. CLS. 100, 101 AND 102

FOR FREIGHT LOGISTICS MANAGEMENT.
FIRST USE 2-13-2008; IN COMMERCE 2-13-2008.

ELEMENTS AMENDED
OWNER ADDRESS

3,972,862. REG. 6-7-2011. CDS FREIGHT HOLDING LTD. (HONG KONG LIMITED CORPORATION) UNIT A, 2/F, CHT TOWER, TERMINAL 8 EAST, CONTAINER PORT ROAD SOUTH, KWAI CHUNG, N.T., HONG KONG., SN 85-009,241. FILED 4-8-2010. PRINCIPAL REGISTER.



THE MARK CONSISTS OF AN ORB WITH THE LETTERS "CDS" INSIDE OF IT.
INT. CL. 35/U.S. CLS. 100, 101 AND 102

FOR FREIGHT LOGISTICS MANAGEMENT.
FIRST USE 2-13-2008; IN COMMERCE 2-13-2008.

ELEMENTS AMENDED
OWNER ADDRESS



3,975,880. REG. 6-7-2011. UNITED AUBURN INDIAN COMMUNITY (UNITED STATES FEDERALLY-RECOGNIZED INDIAN TRIBE) 1200 ATHENS AVENUE, LINCOLN, CA, 95648, SN 85-048,643. FILED 5-26-2010. PRINCIPAL REGISTER.

PANO HALL

THE MARK CONSISTS OF STANDARD CHARACTERS WITHOUT CLAIM TO ANY PARTICULAR FONT, STYLE, SIZE, OR COLOR.

NO CLAIM IS MADE TO THE EXCLUSIVE RIGHT TO USE "HALL", APART FROM THE MARK AS SHOWN.

"PANO" HAS NO MEANING IN A FOREIGN LANGUAGE.

INT. CL. 43/U.S. CLS. 100 AND 101

FOR ARENA SERVICES, NAMELY, PROVIDING FACILITIES FOR CONCERTS, CONVENTIONS AND EXHIBITIONS; PROVIDING CONVENTION FACILITIES.

FIRST USE 4-1-2010; IN COMMERCE 4-1-2010.

ELEMENTS CORRECTED
GOODS/SERVICES



3,976,158. REG. 6-7-2011. EDWIN PIERCE (UNITED STATES INDIVIDUAL) 8635 W. SAHARA #270, LAS VEGAS, NV, 89117, SN 85-113,028. FILED P.R. 8-22-2010; AM. S.R. 4-29-2011. SUPPLEMENTAL REGISTER.

FirearmsCommunity.com

THE MARK CONSISTS OF STANDARD CHARACTERS WITHOUT CLAIM TO ANY PARTICULAR FONT, STYLE, SIZE, OR COLOR.

NO CLAIM IS MADE TO THE EXCLUSIVE RIGHT TO USE ".COM", APART FROM THE MARK AS SHOWN.

INT. CL. 42/U.S. CLS. 100 AND 101

FOR COMPUTER SERVICES, NAMELY, CREATING AN ON-LINE COMMUNITY FOR REGISTERED USERS TO PARTICIPATE IN DISCUSSIONS, GET FEEDBACK FROM THEIR PEERS, FORM VIRTUAL COMMUNITIES, AND ENGAGE IN SOCIAL NETWORKING FEATURING FIREARM AFICIONADOS.

FIRST USE 6-30-2010; IN COMMERCE 6-30-2010.

ELEMENTS CORRECTED
OWNER NAME

3,976,669. REG. 6-14-2011. KABUSHIKI KAISHA HIROSHIMA YASURI SEIZOUSHO (JAPAN CORPORATION) 1511-18, NIGATA SANBASHIDORI, KURE-SHI, HIROSHIMA 737-0154, JAPAN., SN 79-088,365. FILED 9-17-2010. PRINCIPAL REGISTER.



UOCHIKYU

OWNER OF INTERNATIONAL REGISTRATION 1053978 DATED 9-17-2010, EXPIRES 9-17-2020.

THE MARK CONSISTS OF A DESIGN OF A FISH WITH THE WORDS "UOCHIKYU" BELOW.

THE ENGLISH TRANSLATION OF THE FOREIGN WORD(S) IN THE MARK IS: FISH, GLOBE.

INT. CL. 8/U.S. CLS. 23, 28 AND 44

FOR HAND-OPERATED FILES; HAND-OPERATED CUTTING TOOLS.

ELEMENTS CORRECTED
OWNER ADDRESS



3,976,937. REG. 6-14-2011. SORSA HOLDINGS INC (FLORIDA CORPORATION) ST3, 719 EASTERN PK, BKLYN, NY, 11213, SN 85-099,844. FILED 8-4-2010. PRINCIPAL REGISTER.

green smoke

THE MARK CONSISTS OF STANDARD CHARACTERS WITHOUT CLAIM TO ANY PARTICULAR FONT, STYLE, SIZE, OR COLOR.

OWNER OF U.S. REG. NOS. 3,820,206 AND 3,860,744. SEC. 2(F).

INT. CL. 34/U.S. CLS. 2, 8, 9 AND 17

FOR ELECTRONIC CIGARETTES AND COMPONENTS, PARTS AND ACCESSORIES FOR SAME, NAMELY, CARTOMISERS, ATOMISERS [, AND REFILL CARTRIDGES] * THAT EMIT WATER VAPOR *.

FIRST USE 12-7-2004; IN COMMERCE 12-7-2004.

ELEMENTS AMENDED
GOODS/SERVICES



3,980,741. REG. 6-21-2011. INJURED WORKERS PHARMACY, LLC (MASSACHUSETTS LIMITED LIABILITY COMPANY) 9 BRANCH STREET, METHUEN, MA, 01844, SN 85-113,521. FILED 8-23-2010. PRINCIPAL REGISTER.

IWP THE PATIENT ADVOCATE PHARMACY

THE MARK CONSISTS OF STANDARD CHARACTERS WITHOUT CLAIM TO ANY PARTICULAR FONT, STYLE, SIZE, OR COLOR.

NO CLAIM IS MADE TO THE EXCLUSIVE RIGHT TO USE "A PATIENT ADVOCATE PHARMACY", APART FROM THE MARK AS SHOWN.

INT. CL. 35/U.S. CLS. 100, 101 AND 102

FOR MAIL ORDER PHARMACY SERVICES; RETAIL PHARMACY SERVICES.
FIRST USE 10-21-2008; IN COMMERCE 10-21-2008.

ELEMENTS AMENDED
MARK

3,981,500. REG. 6-21-2011. YELLOWSTICKER.COM, INC. (CALIFORNIA CORPORATION) 1156 N. FOUNTAIN WAY, SUITE E, ANAHEIM, CA, 92806, SN 85-178,426. FILED 11-16-2010. PRINCIPAL REGISTER.

YELLOWSTICKER

THE MARK CONSISTS OF STANDARD CHARACTERS WITHOUT CLAIM TO ANY PARTICULAR FONT, STYLE, SIZE, OR COLOR.

INT. CL. 35/U.S. CLS. 100, 101 AND 102

FOR PROVIDING A WEB SITE WHERE USERS CAN POST ITEMS FOR SALE THROUGH ON-LINE CLASSIFIED ADVERTISEMENTS.

FIRST USE 6-1-2010; IN COMMERCE 6-1-2010.

ELEMENTS CORRECTED
OWNER ADDRESS

3,981,502. REG. 6-21-2011. YELLOWSTICKER.COM, INC. (CALIFORNIA CORPORATION) 1156 N. FOUNTAIN WAY, SUITE E, ANAHEIM, CA, 92806, SN 85-178,441. FILED 11-16-2010. PRINCIPAL REGISTER.



THE MARK CONSISTS OF A HORIZONTAL OUTLINE OF A FIGURE 8 WITH THE WORDING "YELLOWSTICKER.COM" INSIDE.

INT. CL. 35/U.S. CLS. 100, 101 AND 102

FOR PROVIDING A WEB SITE WHERE USERS CAN POST ITEMS FOR SALE THROUGH ON-LINE CLASSIFIED ADVERTISEMENTS.

FIRST USE 6-1-2010; IN COMMERCE 6-1-2010.

ELEMENTS CORRECTED
OWNER ADDRESS

3,983,022. REG. 6-28-2011. MEDIATEK INC. (TAIWAN CORPORATION) HSINCHU SCIENCE PARK, NO. 1, DUSING RD. 1., HSINCHU, TAIWAN., SN 77-250,975. FILED 8-9-2007. PRINCIPAL REGISTER.

MEDIA TEK

OWNER OF TAIWAN REG. NO. 01316103, DATED 6-16-2008. EXPIRES 6-16-2018.

OWNER OF U.S. REG. NO. 2,799,358.

THE MARK CONSISTS OF THE TERM "MEDIATEK" IN A STYLIZED FONT.

INT. CL. 9/U.S. CLS. 21, 23, 26, 36 AND 38

FOR INTEGRATED CIRCUITS; SEMI CONDUCTOR CHIPS; PRINTED CIRCUIT BOARDS; OPTICAL STORAGE DEVICES, NAMELY, DISK DRIVES; DIGITAL STILL CAMERAS; DIGITAL CAMCORDERS; SET-UP BOXES, NAMELY, SET TOP BOXES AND POWER DISTRIBUTING BOXES; CELLULAR PHONES; COMPUTER PROGRAMS, NAMELY, COMPUTER PROGRAMS FOR PLAYING AUDIO AND/OR VIDEO DEVICES; COMPUTER PROGRAMS USED TO FACILITATE INTERFACES BETWEEN SOFTWARE AND/OR HARDWARE USED IN WIRELESS COMMUNICATION DEVICES; COMPUTER PROGRAMS FOR CONNECTING CONSUMER ELECTRONIC DEVICES TO WIRELESS COMMUNICATION DEVICES, COMPUTER PROGRAMS FOR CONTROLLING AND USING INTEGRATED CIRCUITS.

FIRST USE ; IN COMMERCE .

INT. CL. 42/U.S. CLS. 100 AND 101

FOR COMPUTER SOFTWARE DESIGN; INTEGRATED CIRCUITS DESIGN FOR OTHERS; SEMI-CONDUCTOR CHIPS DESIGN FOR OTHERS.

FIRST USE ; IN COMMERCE .

ELEMENTS CORRECTED
FOREIGN COUNTRY OF ORIGIN
FOREIGN REG. EXPIRATION DATE

3,985,088. REG. 6-28-2011. SANOFI (FRANCE CORPORATION) 174, AVENUE DE FRANCE, PARIS, FRANCE, 75013, SN 85-164,026. FILED 10-28-2010. PRINCIPAL REGISTER.

JoyStar

THE MARK CONSISTS OF STANDARD CHARACTERS WITHOUT CLAIM TO ANY PARTICULAR FONT, STYLE, SIZE, OR COLOR.

PRIORITY CLAIMED UNDER SEC. 44(D) ON FRANCE APPLICATION NO. 10/3764191, FILED 9-3-2010, REG. NO. 10/3764191, DATED 9-3-2010, EXPIRES 9-3-2020.

OWNER OF U.S. REG. NOS. 3,787,454, 3,806,247 AND OTHERS.

INT. CL. 10/U.S. CLS. 26, 39 AND 44

FOR DIAGNOSTIC APPARATUS FOR GLYCEMIA LEVEL, NAMELY, DEVICES FOR MEASURING BLOOD SUGAR; INJECTABLE INSULIN PENS SOLD EMPTY.

FIRST USE ; IN COMMERCE .

ELEMENTS CORRECTED
OWNER NAME

3,985,089. REG. 6-28-2011. SANOFI (FRANCE CORPORATION) 174, AVENUE DE FRANCE, PARIS, FRANCE, 75013, SN 85-164,033. FILED 10-28-2010. PRINCIPAL REGISTER.

3,985,092. REG. 6-28-2011. SANOFI (FRANCE CORPORATION) 174, AVENUE DE FRANCE, PARIS, FRANCE, 75013, SN 85-164,051. FILED 10-28-2010. PRINCIPAL REGISTER.

JuniorStar

THE MARK CONSISTS OF STANDARD CHARACTERS WITHOUT CLAIM TO ANY PARTICULAR FONT, STYLE, SIZE, OR COLOR.
PRIORITY CLAIMED UNDER SEC. 44(D) ON FRANCE APPLICATION NO. 10/3764190, FILED 9-3-2010, REG. NO. 10/3764190, DATED 9-3-2010, EXPIRES 9-3-2020.
OWNER OF U.S. REG. NOS. 3,787,454, 3,806,247 AND OTHERS.
INT. CL. 10/U.S. CLS. 26, 39 AND 44
FOR DIAGNOSTIC APPARATUS FOR GLYCEMIA LEVEL, NAMELY, DEVICES FOR MEASURING BLOOD SUGAR; INJECTABLE INSULIN PENS SOLD EMPTY.
FIRST USE ; IN COMMERCE .

ELEMENTS CORRECTED
OWNER NAME

VixaStar

THE MARK CONSISTS OF STANDARD CHARACTERS WITHOUT CLAIM TO ANY PARTICULAR FONT, STYLE, SIZE, OR COLOR.
PRIORITY CLAIMED UNDER SEC. 44(D) ON FRANCE APPLICATION NO. 10/3764188, FILED 9-3-2010, REG. NO. 10/3764188, DATED 9-3-2010, EXPIRES 9-3-2020.
OWNER OF U.S. REG. NOS. 3,787,454, 3,806,247 AND OTHERS.
INT. CL. 10/U.S. CLS. 26, 39 AND 44
FOR DIAGNOSTIC APPARATUS FOR GLYCEMIA LEVEL, NAMELY, DEVICES FOR MEASURING BLOOD SUGAR; INJECTABLE INSULIN PENS SOLD EMPTY.
FIRST USE ; IN COMMERCE .

ELEMENTS CORRECTED
OWNER NAME

3,985,093. REG. 6-28-2011. SANOFI (FRANCE CORPORATION) 174, AVENUE DE FRANCE, PARIS, FRANCE, 75013, SN 85-164,059. FILED 10-28-2010. PRINCIPAL REGISTER.

BoliStar

3,985,091. REG. 6-28-2011. SANOFI (FRANCE CORPORATION) 174, AVENUE DE FRANCE, PARIS, FRANCE, 75013, SN 85-164,041. FILED 10-28-2010. PRINCIPAL REGISTER.

THE MARK CONSISTS OF STANDARD CHARACTERS WITHOUT CLAIM TO ANY PARTICULAR FONT, STYLE, SIZE, OR COLOR.
PRIORITY CLAIMED UNDER SEC. 44(D) ON FRANCE APPLICATION NO. 10/3764186, FILED 9-3-2010, REG. NO. 10/3764186, DATED 9-3-2010, EXPIRES 9-3-2020.
OWNER OF U.S. REG. NOS. 3,787,454, 3,806,247 AND OTHERS.
INT. CL. 10/U.S. CLS. 26, 39 AND 44
FOR INJECTABLE INSULIN PENS SOLD EMPTY.

ELEMENTS CORRECTED
OWNER NAME

DoceStar

THE MARK CONSISTS OF STANDARD CHARACTERS WITHOUT CLAIM TO ANY PARTICULAR FONT, STYLE, SIZE, OR COLOR.
PRIORITY CLAIMED UNDER SEC. 44(D) ON FRANCE APPLICATION NO. 10/3764189, FILED 9-3-2010, REG. NO. 10/3764189, DATED 9-3-2010, EXPIRES 9-3-2020.
OWNER OF U.S. REG. NOS. 3,787,454, 3,806,247 AND OTHERS.
INT. CL. 10/U.S. CLS. 26, 39 AND 44
FOR DIAGNOSTIC APPARATUS FOR GLYCEMIA LEVEL, NAMELY, DEVICES FOR MEASURING BLOOD SUGAR; INJECTABLE INSULIN PENS SOLD EMPTY.
FIRST USE ; IN COMMERCE .

ELEMENTS CORRECTED
OWNER NAME

3,988,255. REG. 7-5-2011. ELLUMEN, INC. (VIRGINIA CORPORATION) SUITE 1750, 1101 WILSON BOULEVARD, ARLINGTON, VA, 22209, SN 85-026,611. FILED 4-29-2010. PRINCIPAL REGISTER.

Ellumen

THE MARK CONSISTS OF STANDARD CHARACTERS WITHOUT CLAIM TO ANY PARTICULAR FONT, STYLE, SIZE, OR COLOR.
INT. CL. 42/U.S. CLS. 100 AND 101

FOR COMPUTER SERVICE, NAMELY, ACTING AS AN APPLICATION SERVICE PROVIDER IN THE FIELD OF INFORMATION MANAGEMENT TO HOST COMPUTER APPLICATION SOFTWARE FOR THE PURPOSE OF PROVIDING, HOSTING, MANAGING, DEVELOPING, RESEARCHING, ANALYZING, REPORTING, AND MAINTAINING APPLICATIONS, SOFTWARE, WEBSITES, AND DATABASES OF OTHERS IN THE HEALTHCARE INDUSTRY.

FIRST USE 1-12-2010; IN COMMERCE 2-26-2010.

ELEMENTS CORRECTED
OWNER ADDRESS

3,990,443. REG. 7-5-2011. DARLINGTON COOKIE COMPANY (INDIANA CORPORATION) SUITE B2, 802 MULBERRY STREET, NOBLESVILLE, IN, 46060, SN 77-589,086. FILED 10-9-2008. PRINCIPAL REGISTER.

APPLEWAYS

THE MARK CONSISTS OF STANDARD CHARACTERS WITHOUT CLAIM TO ANY PARTICULAR FONT, STYLE, SIZE, OR COLOR.

INT. CL. 29/U.S. CL. 46

FOR FRUIT-BASED SNACK BARS; PROTEIN BASED, NUTRIENT-DENSE SNACK BARS.

FIRST USE 2-4-2011; IN COMMERCE 2-4-2011.

ELEMENTS CORRECTED
OWNER NAME

* * * * *

TRADEMARK REGISTRATIONS—NEW CERTIFICATES

New Certificates issued under section 7(d) of the Trademark Act of 1946 for the unexpired term of the original registrations.

2,989,572. SHAVE TO SAVE STANDARD CHARACTER
MARK. INT. CL. 36. AMERICAN CANCER SOCIETY
HEARTLAND DIVISION, INC., KANSAS CITY, MO.
REG. 8-30-2005. NEW CERT. SEC. 7(D) TO REGISTRANT.

TO REGISTRANT.

3,552,335. WORLDARTS STANDARD CHARACTER
MARK. INT. CLS. 35 AND 41. MAZZE, AARON MAT-
THEW, CARY, NC. REG. 12-23-2008. NEW CERT. SEC. 7(D)

3,898,289. SWISS SMILE STANDARD CHARACTER MARK.
INT. CLS. 3 AND 21. SWISS SMILE COSMETICS AG, CH-
6010 KRIENS, SWITZERLAND. REG. 6-30-2009. NEW
CERT. SEC. 7(D) TO REGISTRANT.

* * * * *

This page is intentionally blank

INDEX OF REGISTRANTS

AUGUST 23, 2011

(Registered; Renewed; Canceled; Amended, Corrected, etc.; New Certificates; 12c Publications.)

The designation "U.S. Cl." appearing in this section refers to the U.S. class in effect prior to Sep. 1, 1973 rather than the international class which applies to applications filed on or after that date. For adoption of international classification see notice in the OFFICIAL GAZETTE of Jun. 26, 1973 (911 O.G. TM 210).

"PROSHYAN BRANDY FACTORY" LLC, ARMENIA:
4,014,644, PUB. 6-7-2011. INT. CL. 33.

"WHAT A CONCEPT!", AUGUSTA, NJ:
2,911,680, CANC. MULTIPLE CLASS, INT. CLS. 4, 9, 20
AND 21.

A & A SHEET METAL PRODUCTS, INC., LAPORTE, IN:
1,164,199, REN. 7-18-11. INT. CL. 6.

A & M TRANSPORT, INC., GLENDALE, OR:
4,014,979, PUB. 6-7-2011. INT. CL. 39.

A CLASSIC TIME WATCH CO., INC., NEW YORK, NY:
2,911,556, CANC. INT. CL. 14.

A. H. SCHREIBER COMPANY, INC., NEW YORK, NY:
4,017,176, INT. CL. 25.

A. JANSEN B.V., NETHERLANDS:
4,014,615, PUB. 6-7-2011. MULTIPLE CLASS, INT. CLS. 19
AND 37.

A. S. P. INC., SAN ANTONIO, TX, DBA SHOW TECHNOL-
OGY PRODUCTIONS:
2,910,546, CANC. INT. CL. 35.

A.D. VISION, INC., HOUSTON, TX:
2,910,293, CANC. INT. CL. 9.
2,910,669, CANC. INT. CL. 41.
2,910,672, CANC. INT. CL. 41.

A.M.E. INTERNATIONAL, INC., NORTH BRUNSWICK, NJ:
4,014,915, PUB. 6-7-2011. MULTIPLE CLASS, INT. CLS. 2
AND 3.

A.P.M. HEXSEAL CORPORATION, ENGLEWOOD, NJ:
4,014,924, PUB. 6-7-2011. INT. CL. 6.

A.T.X. INTERNATIONAL, INC., LINCOLN, RI:
4,016,506, INT. CL. 16.

A.V.W. INC, FT LAUDERDALE, FL, DBA MAX PROFES-
SIONAL:
4,015,929, PUB. 6-7-2011. INT. CL. 3.

A.V.W. INC., FT LAUDERDALE, FL, DBA MAX PROFES-
SIONAL:
4,015,555, PUB. 6-7-2011. INT. CL. 3.

A&G HEALTHCARE SERVICES, LLC, PLANO, TX:
2,910,121, CANC. INT. CL. 36.

A-LIFE, LLC, BELLVUE, CO:
2,910,242, CANC. INT. CL. 35.
2,910,243, CANC. INT. CL. 35.

A-1 MECHANICAL OF MICHIGAN, LLC, LANSING, MI:
2,910,564, CANC. INT. CL. 37.

A/V MARKETING, INC., INDIANAPOLIS, IN, DBA GISH
TECHNOLOGY, INC.:
4,016,752, INT. CL. 42.

AAB COMPANY, LLC, ANN ARBOR, MI, DBA GREAT
PLAINS BURGER COMPANY:
4,014,811, PUB. 6-7-2011. INT. CL. 43.

AARDVARK MEDICAL SALES, INC., DANVILLE, CA:
4,015,508, PUB. 6-7-2011. INT. CL. 35.

AB MAURI FOOD INC., CORDOVA, TN:
4,017,327, INT. CL. 1.
4,017,328, INT. CL. 30.

ABB INC., CARY, NC:
4,017,196, INT. CL. 9.

ABBOT'S PIZZA COMPANY LLC, BEVERLY HILLS, CA:
4,015,985, PUB. 6-7-2011. INT. CL. 43.
4,015,993, PUB. 6-7-2011. INT. CL. 43.
4,015,998, PUB. 6-7-2011. INT. CL. 43.

ABBOTT LABORATORIES, ABBOTT PARK, IL:
2,910,567, CANC. INT. CL. 5.

ABEND, JOSH C., MENLO PARK, CA:
2,410,277, REN. 7-16-11. INT. CL. 41.

ABERCROMBIE & FITCH TRADING CO., NEW ALBANY,
OH:
3,951,879, COR. INT. CL. 25.

ABL IP HOLDING LLC, CONYERS, GA:
384,876, REN. 7-16-11. U.S. CL. 34 (INT. CL. 16).

ABRASIVE TECHNOLOGY, INC., LEWIS CENTER, OH:
1,194,663, REN. 7-20-11. INT. CL. 10.

ABS FAX TECHNOLOGIES, INC., HOUSTON, TX:
2,910,600, CANC. INT. CL. 38.

ABSOLUTE INNOVATIONS, INC., OSCEOLA, IN:
2,910,044, CANC. INT. CL. 1.

ABYSS GROUP INC, STAMFORD, CT:
4,017,323, INT. CL. 9.

AC NIELSEN (US), INC., SCHAUMBURG, IL:
2,911,688, CANC. MULTIPLE CLASS, INT. CLS. 35 AND
42.
2,911,689, CANC. MULTIPLE CLASS, INT. CLS. 35 AND
42.

AC NUTRITION, LP, OMAHA, NE:
1,178,396, REN. 7-19-11. INT. CL. 31.

ACADEMY OF TELEVISION ARTS AND SCIENCES,
NORTH HOLLYWOOD, CA AND NATIONAL ACADEMY
OF TELEVISION ARTS AND SCIENCES, THE, NEW
YORK, NY:
1,649,437, REN. 7-20-11. MULTIPLE CLASS, INT. CLS. 16
AND 41.

ACADIA CANDLE COMPANY INC., DUNDAS ONTARIO
L9J 1H2, CANADA:
2,911,525, CANC. INT. CL. 4.

ACCESS MARKETING, INC, GROVER BEACH, CA:
2,450,187, CANC. INT. CL. 12.

ACCO BRANDS CORPORATION, LINCOLNSHIRE, IL:
2,911,786, CANC. INT. CL. 16.

ACCORDANT HEALTH SERVICES, L.L.C., GREENSBORO,
NC:
2,489,321, REN. 7-15-11. INT. CL. 42.

ACCREDITATION COUNCIL FOR BUSINESS SCHOOLS
AND PROGRAMS, OVERLAND PARK, KS, AKA ACBSP:
4,016,903, INT. CL. 42.

ACCREDITATION COUNCIL FOR SURGICAL QUALITY,
BOSTON, MA:
4,014,996, PUB. 6-7-2011. INT. CL. 41.

ACCUCODE, INC., CENTENNIAL, CO:
4,017,159, INT. CL. 35.

ACCUPAX, INC., CHICAGO, IL:
2,911,092, CANC. INT. CL. 35.

ACCURIDE CORPORATION, EVANSVILLE, IN, FIRE-
STONE TIRE & RUBBER COMPANY, THE, AKRON, OH:
912,540, REN. 7-19-11. U.S. CL. 19 (INT. CL. 12).

ACETO AGRICULTURAL CHEMICALS CORPORATION,
LAKE SUCCESS, NY:
4,016,591, INT. CL. 5.

ACH, YASMIN, SHOHAM, ISRAEL:
4,014,279, PUB. 6-7-2011. MULTIPLE CLASS, INT. CLS. 16
AND 41.

ACOLOGIX, INC., HAYWARD, CA:
2,911,400, CANC. INT. CL. 5.

ACOUSTIGUIDE INCORPORATED, NEW YORK, NY:
2,479,742, REN. 7-18-11. INT. CL. 41.

- ACROVANTAGE, LTD., ANDOVER, MA:
1,651,752. REN. 7-19-11. INT. CL. 41.
- ACS INTERNET, INC., ANCHORAGE, AK:
2,460,813. REN. 7-19-11. INT. CL. 38.
- ACUFOCUS, INC., IRVINE, CA:
4,016,665. INT. CL. 10.
- AD ENTERTAINMENT, LLC, ROSWELL, GA:
2,911,014. CANC. INT. CL. 41.
- AD-CLICX B.V., AL NAARDEN, NETHERLANDS:
4,014,545. PUB. 6-7-2011. MULTIPLE CLASS, INT. CLS. 12 AND 25.
- ADAMS ENTERPRISES, INC, CARSON CITY, NV:
2,910,691, CANC. MULTIPLE CLASS, INT. CLS. 28 AND 35.
- ADAMS WINERY, LLC, HEALDSBURG, CA:
4,016,847. INT. CL. 33.
- ADAMS, ADAMS & ADAMS, LLC, HUNTINGTON BEACH, CA:
4,017,311. INT. CL. 35.
- ADAPTEC, INC., MILPITAS, CA:
2,421,713. REN. 7-20-11. INT. CL. 9.
- ADEPT FASTENERS, VALENCIA, CA:
4,015,314. PUB. 6-7-2011. INT. CL. 35.
- ADESA, INC., CARMEL, IN, ADESA PROPERTIES, INC., DIMONDALE, MI:
2,504,409. REN. 7-19-11. INT. CL. 35.
- ADESA, INC., CARMEL, IN:
2,504,410. REN. 7-18-11. INT. CL. 35.
- ADJUTANT IT, WALNUT CREEK, CA:
4,017,218. INT. CL. 42.
- ADJUVANT, INC., FAIRFAX, VA:
2,911,792. CANC. INT. CL. 35.
- ADLER FELS WINERY, LLC, THOUSAND OAKS, CA:
2,557,983. REN. 7-18-11. INT. CL. 33.
- ADOCIA, FRANCE:
4,014,525. PUB. 6-7-2011. MULTIPLE CLASS, INT. CLS. 1 AND 5.
- ADONIS FURNITURE LLC, OAKLAND, CA:
4,014,441. PUB. 6-7-2011. INT. CL. 20.
- ADS TECHNOLOGIES, INC., CERRITOS, CA:
2,910,260. CANC. INT. CL. 9.
- ADSTRACTS, INC., RALEIGH, NC:
2,911,794. CANC. INT. CL. 35.
- ADVANCE MAGAZINE PUBLISHERS INC., NEW YORK, NY:
4,016,635. MULTIPLE CLASS, INT. CLS. 35, 41 AND 45.
4,016,976. INT. CL. 9.
- ADVANCE PRODUCTS & SYSTEMS, INC., SCOTT, LA:
4,017,092. INT. CL. 17.
- ADVANCED DIGITAL DATA, INC., FLANDERS, NJ:
2,479,039. REN. 7-18-11. INT. CL. 9.
- ADVANCED INTERCONNECTIONS CORPORATION, WEST WARWICK, RI:
1,671,020. REN. 7-19-11. INT. CL. 9.
- ADVANCED INTERNATIONAL MARKETING CORPORATION, ST. LOUIS PARK, MN, DBA AAA-CLASSIC DANCERS:
4,015,345. PUB. 6-7-2011. INT. CL. 41.
- ADVANCED LIGHTING TECHNOLOGIES, INC., SOLON, OH:
4,016,207. MULTIPLE CLASS, INT. CLS. 37 AND 42.
- ADVANCED MAGNETIC SOLUTIONS, INC., CHATTANOOGA, TN:
2,911,798. CANC. MULTIPLE CLASS, INT. CLS. 35 AND 42.
- ADVANCED RAIN WATER SYSTEMS INC., EAST MCKEESPORT, PA:
2,909,612. CANC. INT. CL. 11.
- ADVANCED THERMAL PRODUCTS, INC., IRIVNE, CA:
4,014,756. PUB. 6-7-2011. INT. CL. 17.
- ADVANCED THERMAL PRODUCTS, INC., IRVINE, CA:
4,014,757. PUB. 6-7-2011. INT. CL. 17.
- ADVENTIVE, INC., ROCHESTER, NY:
4,016,299. INT. CL. 42.
- ADVICE COMPANY, SAUSALITO, CA:
4,014,905. PUB. 6-7-2011. INT. CL. 42.
- ADVISANT INTERNATIONAL, INC, BRENTWOOD, TN:
2,910,448, CANC. MULTIPLE CLASS, INT. CLS. 16, 35, 36, 37, 41 AND 42.
- ADVOCAL, SACRAMENTO, CA:
4,015,681. PUB. 6-7-2011. INT. CL. 35.
- AEG GESELLSCHAFT FUER MODERNE INFORMATIONS-SYSTEME MBH, ULM, FED REP GERMANY:
4,014,247. PUB. 4-29-2008. MULTIPLE CLASS, INT. CLS. 9, 11 AND 37.
- AERATION INDUSTRIES INTERNATIONAL, LLC, CHASKA, MN:
2,527,750. REN. 7-19-11. INT. CL. 7.
- AERIES SOFTWARE, INC., ANAHEIM, CA:
2,472,145. REN. 7-21-11. INT. CL. 9.
- AERODATA AG, BRAUNSCHWEIG, FED REP GERMANY:
2,909,808. CANC. MULTIPLE CLASS, INT. CLS. 9 AND 38.
- AEROXCHANGE LTD., IRVING, TX:
4,016,061. PUB. 6-7-2011. INT. CL. 35.
- AES INTERIORS & ASSOCIATES INC, BOCA RATON, FL:
4,014,848. PUB. 6-7-2011. INT. CL. 42.
- AETNA BUILDING MAINTENANCE, INC., COLUMBUS, OH:
4,015,561. PUB. 6-7-2011. INT. CL. 37.
- AFFINION BENEFITS GROUP, LLC, FRANKLIN, TN:
2,461,343. REN. 7-18-11. INT. CL. 35.
- AFFINION LOYALTY GROUP, INC., RICHMOND, VA:
2,911,429. CANC. INT. CL. 36.
- AFFINIUM PHARMACEUTICALS, INC., TORONTO, ONTRIO M5J 1V6, CANADA:
2,909,440. CANC. INT. CL. 42.
- AFRICAN TERROIR (PROPRIETARY) LIMITED, WESTERN CAPE, SOUTH AFRICA:
4,014,334. PUB. 1-26-2010. INT. CL. 33.
- AFRIKAN DESCENT YOUTH AFFAIRS (ADYA), SEATTLE, WA, DBA ADYA:
4,014,339. PUB. 6-7-2011. INT. CL. 41.
- AFTER-SCHOOL ALL-STAR, LOS ANGELES, CA:
4,014,845. PUB. 6-7-2011. INT. CL. 36.
- AF2 ENTERPRISES, LLC, CHICAGO, IL:
2,910,150. CANC. INT. CL. 41.
- AGC, LLC, CLEVELAND, OH:
4,016,638. INT. CL. 16.
- AGGREKO, LLC, NEW IBERIA, LA:
1,631,985. REN. 7-19-11. INT. CL. 42.
1,632,929. REN. 7-19-11. INT. CL. 7.
- AGP CREATIVE LLC, RAHWAY, NJ, DBA AGP CREATIVE LLC:
4,015,355. PUB. 6-7-2011. INT. CL. 16.
- AGR SUBSEA AS, NORWAY:
4,014,532. PUB. 6-7-2011. MULTIPLE CLASS, INT. CLS. 7 AND 37.
- AGRASYST, SPOKANE, WA:
4,016,088. PUB. 6-7-2011. INT. CL. 1.
- AGRICOLA SAN JOSE DE PERALILLO S.A., SANTIAGO, CHILE:
2,470,454. REN. 7-15-11. INT. CL. 33.
- AGRIUM INC., CALGARY, ALBERTA, CANADA:
4,016,824. INT. CL. 9.
- AGS ANDREAS GRUBER SOFTWARE GMBH, FED REP GERMANY:
4,014,515. PUB. 6-7-2011. MULTIPLE CLASS, INT. CLS. 9, 35 AND 42.
- AGUIRRE, THOMAS, A, CEDAR PLACE, TX:
2,911,713. CANC. INT. CL. 4.
- AGVENTURE, L.L.C., FREDERICK, MD, DBA WILLARD:
4,015,252. PUB. 6-7-2011. INT. CL. 44.
- AGVERRA, LLC, KATY, TX:
4,015,822. PUB. 6-7-2011. INT. CL. 1.
- AH-HA VOCABULARY, BANNING, CA:
2,911,099. CANC. INT. CL. 16.
- AHLSTROM CORPORATION, FIN-00130 HELSINKI, FINLAND:
2,909,456. CANC. MULTIPLE CLASS, INT. CLS. 16, 17, 21, 23 AND 24.
- AIKEN LEGAL SEARCH, LLC, ATLANTA, GA:
4,016,198. INT. CL. 35.
- AINSWORTH GAME TECHNOLOGY, NEWINGTON, AUSTRALIA:
4,017,118. INT. CL. 9.

AIR ANGELS, INC., WEST CHICAGO, IL:
2,909,523, CANC. INT. CL. 39.

AIR CHINA LIMITED, SHUNYI, BEIJING, CHINA:
3,707,627, AM. INT. CL. 39.

AIR CHINA LIMITED, SHUNYI DISTRICT BEIJING, CHINA:
4,015,082, PUB. 6-7-2011. MULTIPLE CLASS, INT. CLS. 37 AND 39.

AIR MAX IMPORT & EXPORT, INC., MIAMI, FL:
2,910,201, CANC. INT. CL. 25.
2,910,202, CANC. INT. CL. 25.

AIRBRUSH CITY, INC., NAMP, ID:
2,911,073, CANC. INT. CL. 7.

AIRGAS, INC., RADNOR, PA, AIRGAS, INC., RADNOR, PA:
1,646,540, REN. 7-15-11. MULTIPLE CLASS, INT. CLS. 1 AND 5.

AIRGUIDE PUBLICATIONS, INC., LONG BEACH, CA:
896,061, REN. 7-18-11. U.S. CL. 38 (INT. CL. 16).

AIRME, INC., COLORADO SPRINGS, CO:
2,412,356, CANC. INT. CL. 42.

AJI ICHIBAN COMPANY LIMITED, NEW TERRITORIES, HONG KONG:
2,500,734, REN. 7-15-11. INT. CL. 29.

AKA ENTERPRISES, INC., MORGANTOWN, WV, DBA BENT WILLEY'S:
2,536,824, REN. 7-21-11. INT. CL. 42.

AKINS, ARTHUR J, PORTLAND, OR, DBA TREE IN A BOX:
4,015,425, PUB. 6-7-2011. INT. CL. 31.

AKRON GENERAL MEDICAL CENTER, AKRON, OH:
2,483,886, REN. 7-21-11. MULTIPLE CLASS, INT. CLS. 35 AND 42.

AKZO NOBEL COATINGS INTERNATIONAL B.V., NL-6824 BM ARNHEM, NETHERLANDS:
4,014,596, PUB. 6-7-2011. INT. CL. 2.
4,014,622, PUB. 6-7-2011. INT. CL. 3.
4,014,623, PUB. 6-7-2011. INT. CL. 2.

AL WISSAM, INC., DETROIT, MI:
2,910,609, CANC. INT. CL. 14.

AL ZAIN TRADING COMPANY, W.L.L., MANAMA, BAHRAIN:
2,911,551, CANC. INT. CL. 14.

AL-KHAWAJA, MAHMOUD, DUBAI, UNITED ARAB EMIR.:
4,017,071, INT. CL. 36.

ALAN B. GARFINKEL, P.A., MAITLAND, FL:
2,911,236, CANC. INT. CL. 42.

ALASKA STOCK LLC, ANCHORAGE, AK:
2,588,033, REN. 7-15-11. INT. CL. 42.

ALASKAFIT, LLC, GIRWOOD, AK:
4,015,836, PUB. 6-7-2011. INT. CL. 41.

ALASKAN FEAST, INC, BRONX, NY:
4,015,633, PUB. 6-7-2011. INT. CL. 29.

ALATHEIA PROSTHETIC REHABILITATION CENTER, BRANDON, MS:
2,471,562, REN. 7-18-11. INT. CL. 10.

ALBENDESIGN LLC, SANTA CRUZ, CA:
2,910,663, CANC. INT. CL. 41.

ALBERIAN AND AULDE INC, WEEHAWKEN, NJ:
2,909,969, CANC. INT. CL. 14.

ALBERT GAD LTD., NEW YORK, NY:
4,015,131, PUB. 3-22-2011. INT. CL. 14.

ALBIS PLASTIC GMBH, D-20539 HAMBURG, FED REP GERMANY:
2,472,642, REN. 7-17-11. INT. CL. 1.

ALBUMS INC., STRONGSVILLE, OH:
4,015,406, PUB. 6-7-2011. INT. CL. 35.

ALCOR LIFE EXTENSION FOUNDATION, SCOTTSDALE, AZ:
2,517,071, REN. 7-18-11. INT. CL. 42.

ALEX APPAREL GROUP INC., NEW YORK, NY:
1,682,413, REN. 7-18-11. INT. CL. 25.

ALEXANDER ANDREW, INC., COMPTON, CA, DBA FALL-TECH:
4,017,189, INT. CL. 9.

ALEXANDER, JAMES M., CHAPPAQUA, NY:
4,016,390, INT. CL. 42.

ALFRED DUNHILL LIMITED, LONDON W1J 5QT, ENGLAND:
1,172,665, REN. 7-18-11. INT. CL. 42.

ALFREDHOUSE ELDERCARE, INC., ROCKVILLE, MD:
4,015,859, PUB. 6-7-2011. INT. CL. 43.

ALIMENTOS FORTUNA, S.A., SANTO DOMINGO, DOMINICAN REP:
4,014,685, PUB. 6-7-2011. INT. CL. 30.

ALL WOOD CABINETRY, LLC, NORTH PALM BEACH, FL:
4,016,533, INT. CL. 20.

ALLEGIANCE SOFTWARE, INC., SOUTH JORDAN, UT:
4,015,024, PUB. 6-7-2011. INT. CL. 41.

ALLEN MEDICAL SYSTEMS, INC., BATESVILLE, IN:
2,911,329, CANC. INT. CL. 10.

ALLIANCE APPAREL, INC., COMMERCE, CA:
4,016,030, PUB. 6-7-2011. INT. CL. 25.

ALLIANCE OF VISUAL ARTISTS, ATLANTA, GA:
4,014,943, PUB. 6-7-2011. INT. CL. 35.

ALLIANT TECHSYSTEMS INC., MINNEAPOLIS, MN:
4,014,856, PUB. 6-7-2011. INT. CL. 13.
4,014,863, PUB. 6-7-2011. INT. CL. 13.

ALLIED BUILDING PRODUCTS CORPORATION, EAST RUTHERFORD, NJ:
4,016,421, MULTIPLE CLASS, INT. CLS. 1, 17 AND 19.

ALLIED CERAMICS INTERNATIONAL, LAKE GEORGE, NY:
2,911,269, CANC. INT. CL. 40.
2,911,270, CANC. INT. CL. 40.

ALLIED ENERGY, BOWLING GREEN, KY:
2,910,882, CANC. MULTIPLE CLASS, INT. CLS. 40 AND 42.

ALLIED SEED, LLC, MACON, MO:
4,014,762, PUB. 6-7-2011. INT. CL. 31.

ALLIED 100, LLC, WOODRUFF, WI:
4,016,419, INT. CL. 10.

ALLIGATOR RAY'S OYSTER BAR INC, CLARKSVILLE, AR:
2,911,246, CANC. INT. CL. 43.

ALLISON CLINICAL ENTERPRISES, SOUTHLAKE, TX:
4,014,736, PUB. 6-7-2011. INT. CL. 3.

ALLSCRIPTS-MISYS HEALTHCARE SOLUTIONS, INC., CHICAGO, IL:
4,014,852, PUB. 6-7-2011. INT. CL. 35.

ALLSTATE INSURANCE COMPANY, NORTHBROOK, IL:
2,911,145, CANC. INT. CL. 35.
4,015,260, PUB. 6-7-2011. MULTIPLE CLASS, INT. CLS. 35, 36, 37 AND 39.

ALLY FINANCIAL INC., DETROIT, MI:
4,015,248, PUB. 6-7-2011. INT. CL. 36.

ALNO AG, 88630 PFULLENDORF, FED REP GERMANY:
4,014,467, PUB. 6-7-2011. MULTIPLE CLASS, INT. CLS. 19, 20 AND 21.

ALOK INTERNATIONAL INC., DALLAS, TX:
4,017,058, INT. CL. 24.

ALLOXXI INTERNATIONAL CORPORATION, SHERMAN OAKS, CA:
4,017,091, INT. CL. 3.

ALPHA SIGMA ALPHA, INDIANAPOLIS, IN:
4,015,768, PUB. 6-7-2011. INT. CL. 25.
4,015,831, PUB. 6-7-2011. INT. CL. 14.

ALPHA SKY ASSOCIATES LTD, SINGAPORE:
4,014,546, PUB. 6-7-2011. INT. CL. 25.

ALPHA SUN N.V., HASSELT, BELGIUM:
2,910,796, CANC. INT. CL. 11.

ALPHA Z MOTOR BOATS OF NEVADA, INC., TAMPA, FL:
2,911,129, CANC. INT. CL. 12.

ALPHACRITTERS, INC., TORONTO, ONTARIO, CANADA:
2,909,811, CANC. INT. CL. 25.

ALPINE ELECTRONICS, INC., TOKYO 141, JAPAN:
2,478,773, REN. 7-19-11. INT. CL. 9.

ALTAIR ENGINEERING, INC., TROY, MI:
2,422,175, REN. 7-20-11. INT. CL. 9.

ALTE POWERTRAIN TECHNOLOGIES, AUBURN HILLS, MI:
4,016,678, MULTIPLE CLASS, INT. CLS. 40 AND 42.

ALTEC LANSING, A DIVISION OF PLANTRONICS, INC., MILFORD, PA:
1,127,460, CANC. MULTIPLE CLASS, INT. CLS. 9 AND

14.
 ALTERNA HOLDINGS CORP., CENTURY CITY, CA, AL-
 TERNA, INC., LOS ANGELES, CA:
 2,410,914. REN. 7-19-11. INT. CL. 3.
 ALTERNATIVE HEALTH PRODUCTS, INC., TAMARAC,
 FL:
 2,911,076. CANC. INT. CL. 5.
 ALTO OF SOUTH FLORIDA, INC., PLANTATION, FL:
 4,016,990. INT. CL. 18.
 ALULI, KALE F., KILAUEA, HI:
 4,016,347. INT. CL. 9.
 ALVAREZ, AGUEDA, LINARES, N.L., CP 67755, MEXICO:
 2,910,042. CANC. INT. CL. 39.
 AMANI AIRLINES INCORPORATED, DARIEN, IL:
 2,909,816. CANC. INT. CL. 39.
 AMANRESORTS LIMITED, CENTRAL, HONG KONG:
 4,015,689. PUB. 6-7-2011. INT. CL. 43.
 AMBAC FINANCIAL GROUP, INC., NEW YORK, NY:
 2,411,797. CANC. INT. CL. 36.
 AMBAC INTERNATIONAL CORPORATION, COLUMBIA,
 SC:
 1,689,848. REN. 7-18-11. INT. CL. 7.
 AMBION, INC., AUSTIN, TX:
 1,673,938. REN. 7-18-11. INT. CL. 1.
 AMBROZIAK, MARYANNE, RIO RANCHO, NM:
 4,015,671. PUB. 6-7-2011. INT. CL. 35.
 AMC SALES, INC., MINNEAPOLIS, MN:
 4,014,875. PUB. 6-7-2011. INT. CL. 28.
 AMC, INC., ATLANTA, GA:
 2,909,785. CANC. INT. CL. 35.
 2,909,786. CANC. INT. CL. 35.
 2,909,848. CANC. INT. CL. 41.
 AMDIPHARM INTERNATIONAL LIMITED, ST. HELIER,
 JERSEY:
 2,909,621. CANC. MULTIPLE CLASS, INT. CLS. 5 AND
 10.
 AMERIBAG, INC., KINGSTON, NY:
 2,910,988. CANC. INT. CL. 18.
 AMERICA'S COLLECTIBLES NETWORK, INC., KNOX-
 VILLE, TN:
 2,582,926. REN. 7-15-11. INT. CL. 14.
 AMERICAN ART CLAY CO., INC., INDIANAPOLIS, IN,
 AMERICAN ART CLAY COMPANY, INDIANAPOLIS, IN:
 548,372. REN. 7-15-11. U.S. CL. 1 (INT. CL. 16).
 AMERICAN ASSOCIATION OF STATE HIGHWAY AND
 TRANSPORTATION OFFICIALS, WASHINGTON, DC:
 2,471,730. REN. 7-18-11. INT. CL. 42.
 AMERICAN BANKNOTE CORPORATION, FORT LEE, NJ:
 4,016,361. MULTIPLE CLASS, INT. CLS. 9 AND 16.
 4,016,363. MULTIPLE CLASS, INT. CLS. 9 AND 16.
 AMERICAN BIBLE SOCIETY, NEW YORK, NY:
 4,014,911. PUB. 6-7-2011. INT. CL. 35.
 4,014,914. PUB. 6-7-2011. INT. CL. 35.
 AMERICAN BLUE RIBBON HOLDINGS, LLC, DENVER,
 CO:
 4,016,699. INT. CL. 40.
 AMERICAN BUILDING SUPPLY, INC., SACRAMENTO,
 CA:
 2,909,799. CANC. MULTIPLE CLASS, INT. CLS. 6 AND
 37.
 AMERICAN CANCER SOCIETY, HIGH PLAINS DIVISION,
 INC., KANSAS CITY, MO:
 2,989,572. NEW CERT. 8-23-2011. INT. CL. 36.
 AMERICAN CONCRETE PAVEMENT ASSOCIATION, SKO-
 KIE, IL:
 2,909,559. CANC. INT. CL. 16.
 AMERICAN EXPRESS COMPANY, NEW YORK, NY:
 2,911,736. CANC. INT. CL. 36.
 AMERICAN FUNDS DISTRIBUTORS, INC., LOS ANGELES,
 CA:
 2,441,920. REN. 7-15-11. INT. CL. 36.
 2,540,480. REN. 7-18-11. INT. CL. 36.
 AMERICAN HUMANE ASSOCIATION, ENGLEWOOD, CO:
 4,014,755. PUB. 6-7-2011. U.S. CL. A.
 AMERICAN INSTITUTE FOR CANCER RESEARCH, WA-
 SHINGTON, DC:
 4,014,922. PUB. 6-7-2011. MULTIPLE CLASS, INT. CLS.
 16, 35, 36, 41 AND 44.
 AMERICAN INSTITUTE OF ARCHITECTS, THE, WA-
 SHINGTON, DC, PRODUCTION SYSTEMS FOR ARCHI-
 TECTS & ENGINEERS, INC., CHICAGO, IL:
 913,632. REN. 7-15-11. MULTIPLE CLASS, U.S. CLS. 38
 (INT. CLS. 9, 16 AND 28) AND 100 (INT. CL. 42).
 AMERICAN INSTITUTE OF CERTIFIED PUBLIC ACCOUN-
 TANTS, NEW YORK, NY:
 4,017,355. U.S. CL. B.
 AMERICAN INSTITUTE OF GRAPHIC ARTS-SAN FRAN-
 CISCO CHAPTER, SAN FRANCISCO, CA, AKA AIGA SAN
 FRANCISCO:
 4,014,907. PUB. 6-7-2011. INT. CL. 41.
 AMERICAN INTERNATIONAL GROUP, INC., NEW YORK,
 NY:
 2,496,508. REN. 7-21-11. MULTIPLE CLASS, INT. CLS. 35,
 36 AND 42.
 2,910,286. CANC. INT. CL. 36.
 AMERICAN INTERNATIONAL RADIO, INC., ROLLING
 MEADOWS, IL:
 4,017,282. INT. CL. 35.
 AMERICAN JANITORIAL CHEMICAL COMPANY INC.,
 SAN CLEMENTE, CA:
 2,911,743. CANC. MULTIPLE CLASS, INT. CLS. 3 AND 5.
 AMERICAN LIME TECHNOLOGY, LLC, CHICAGO, IL:
 4,014,840. PUB. 6-7-2011. INT. CL. 17.
 AMERICAN MANAGEMENT SERVICES, LLC, DALLAS,
 TX:
 4,016,399. MULTIPLE CLASS, INT. CLS. 35 AND 41.
 4,016,400. MULTIPLE CLASS, INT. CLS. 35 AND 41.
 AMERICAN MASTERTECH SCIENTIFIC, INC., LODI, CA,
 DBA AMERICAN MASTERTECH SCIENTIFIC, INC.:
 4,017,182. INT. CL. 10.
 AMERICAN MULTI-CINEMA, INC., KANSAS CITY, MO:
 2,910,173. CANC. INT. CL. 35.
 AMERICAN PAN COMPANY, URBANA, OH:
 4,014,990. PUB. 6-7-2011. MULTIPLE CLASS, INT. CLS.
 21, 35 AND 37.
 AMERICAN PUBLIC TRANSPORTATION ASSOCIATION,
 WASHINGTON, DC:
 4,017,039. INT. CL. 35.
 4,017,040. INT. CL. 35.
 AMERICAN REPUBLIC INSURANCE COMPANY, DES
 MOINES, IA:
 2,909,662. CANC. MULTIPLE CLASS, INT. CLS. 9, 16, 18,
 21, 35, 36 AND 41.
 AMERICAN RESIDENTIAL SERVICES, LLC, MEMPHIS,
 TN:
 1,660,089. REN. 7-18-11. INT. CL. 37.
 AMERICAN TECHNOLOGIES, INC., ORANGE, CA:
 4,016,330. MULTIPLE CLASS, INT. CLS. 37 AND 40.
 AMERICAN TIME & SIGNAL CO., DASSEL, MN:
 2,910,271. CANC. INT. CL. 20.
 AMERICAN TRAFFIC SAFETY SERVICES ASSOCIATION,
 INC., FREDERICKSBURG, VA:
 4,015,107. PUB. 6-7-2011. INT. CL. 41.
 AMERICAN UNIVERSITY, WASHINGTON, DC:
 2,505,839. REN. 7-18-11. INT. CL. 41.
 4,016,826. INT. CL. 41.
 4,016,827. INT. CL. 41.
 4,016,830. INT. CL. 41.
 4,016,831. INT. CL. 41.
 AMERICAN VELODUR METAL, INC., SCITUATE, MA:
 2,455,193. REN. 7-18-11. INT. CL. 1.
 AMERIPRISE FINANCIAL, INC., MINNEAPOLIS, MN:
 4,017,193. INT. CL. 36.
 AMERIQUEST MORTGAGE COMPANY, ORANGE, CA:
 2,909,941. CANC. INT. CL. 36.
 AMERITAS LIFE INSURANCE CORP., LINCOLN, NE:
 2,113,921. CANC. INT. CL. 36.
 AMI BEARINGS, INC., MT. PROSPECT, IL:
 2,553,020. REN. 7-15-11. INT. CL. 7.
 AMI ENTERTAINMENT NETWORK, INC., BRISTOL, PA:
 4,016,118. PUB. 6-7-2011. INT. CL. 9.
 AMN HEALTHCARE, INC., SAN DIEGO, CA:
 2,489,132. REN. 7-19-11. INT. CL. 35.
 AMOREPACIFIC CORPORATION, SEOUL, REPUBLIC OF
 KOREA:
 2,911,725. CANC. INT. CL. 3.

AMOS PRESS, INC., SIDNEY, OH:
2,534,202. REN. 7-21-11. INT. CL. 16.

AMPAC ENTERPRISES, INC., SHIRLEY, MA:
4,016,701. MULTIPLE CLASS, INT. CLS. 9, 25 AND 28.

AMPHENOL CORPORATION, WALLINGFORD, CT:
4,017,045. INT. CL. 9.

AMSCOT CORPORATION, TAMPA, FL:
4,016,397. MULTIPLE CLASS, INT. CLS. 35 AND 36.

AMTECO, INC., PACIFIC, MO:
2,494,529. REN. 7-15-11. INT. CL. 2.

AMTOTE INTERNATIONAL, INC., HUNT VALLEY, MD:
1,656,117. REN. 7-18-11. INT. CL. 9.

ANACARDIUM LLC, WILMINGTON, DE:
2,909,477. CANC. MULTIPLE CLASS, INT. CLS. 5, 29, 30,
31, 41, 42 AND 44.

ANCHOR WALL SYSTEMS, INC., MINNETONKA, MN:
4,017,296. INT. CL. 19.

ANDERSON PUBLISHING, LTD., OCEAN, NJ:
2,910,028. CANC. INT. CL. 41.

ANDERSON, CONSTANCE E., NEWCASTLE, WA, DBA THE
JOYFUL MULLIGAN:
4,015,724. PUB. 6-7-2011. INT. CL. 41.

ANDERSON, DAVE, AGOURA HILLS, CA:
2,467,552. REN. 7-17-11. INT. CL. 16.

ANDRÉ MEYER VENTURES LLC, NEW YORK, NY:
2,910,753. CANC. INT. CL. 36.

ANDROMEDA TRAINING INC., CHAPEL HILL, NC:
4,015,372. PUB. 6-7-2011. INT. CL. 41.

ANDUJAR, MIRIAM, NORTH BERGEN, NJ:
2,909,418. CANC. INT. CL. 42.

ANDYG.COM, LLC, BOSTON, MA:
2,910,505. CANC. INT. CL. 25.
2,910,506. CANC. INT. CL. 25.

ANGEL SECURE NETWORKS, INC., BELMONT, MA:
2,911,333. CANC. INT. CL. 9.

ANGELS FLIGHT RAILWAY FOUNDATION, LOS AN-
GELES, CA, HAMPTON INDUSTRIES, INC., KINSTON,
NC:
1,648,895. REN. 7-20-11. INT. CL. 25.

ANGELS ON EARTH HOME HEALTH, INC., MONTCLAIR,
CA:
4,015,629. PUB. 6-7-2011. INT. CL. 44.

ANHEUSER BUSCH, INCORPORATED, ST. LOUIS, MO:
4,017,066. INT. CL. 32.

ANHEUSER-BUSCH, INCORPORATED, ST. LOUIS, MO:
4,017,190. INT. CL. 32.

ANNAYAKE, 75008 PARIS, FRANCE:
2,909,859. CANC. INT. CL. 3.

ANSCO, INC., NEW YORK, NY:
4,016,034. PUB. 6-7-2011. INT. CL. 35.
4,016,905. INT. CL. 36.

ANOVA COFFEE, LLC, ORLANDO, FL:
4,016,043. PUB. 6-7-2011. INT. CL. 30.

ANSBACH SR., JAMES, TOMS RIVER, NJ:
4,015,097. PUB. 6-7-2011. INT. CL. 45.

ANTHONY FONTANA, STATEN ISLAND, NY AND
BRIELLE DAHAN, STATEN ISLAND, NY:
4,015,038. PUB. 6-7-2011. INT. CL. 35.

ANTIOCHIAN ORTHODOX CHRISTIAN ARCHDIOCESE
OF NORTH AMERICA, ENGLEWOOD, NJ:
2,412,693. CANC. INT. CL. 16.

ANTONIO FUSCO INTERNATIONALS.A. LUSSEMBUR-
GO. SUCCURSALE DI LUGANO, 6900 LUGANO, SWIT-
ZERLAND:
2,909,355. CANC. MULTIPLE CLASS, INT. CLS. 9, 14, 18
AND 25.

ANUNTIS SEGUNDAMANO HOLDINGS, S.L., BARCELO-
NA, SPAIN:
4,014,857. PUB. 6-7-2011. MULTIPLE CLASS, INT. CLS.
35, 38 AND 42.

ANY INC., OKLAHOMA CITY, OK:
4,016,307. U.S. CL. B.

ANYTHING IS POSH ABLE EVENTS, ORLANDO, FL:
4,015,867. PUB. 6-7-2011. INT. CL. 41.

AOL INC., DULLES, VA:
4,015,921. PUB. 6-7-2011. INT. CL. 41.

AP EXHAUST PRODUCTS, INC., GOLDSBORO, NC:
2,493,182. REN. 7-18-11. INT. CL. 12.

AP&G CO., INC., BROOKLYN, NY:
4,016,425. INT. CL. 21.
4,016,478. INT. CL. 21.

APEE LTD, COAL VALLEY, IL:
4,014,714. PUB. 6-7-2011. INT. CL. 37.

APEGO, INC., HOUSTON, TX:
2,412,967. CANC. INT. CL. 16.

APENIMED, INC., MINNEAPOLIS, MN:
4,015,761. PUB. 6-7-2011. MULTIPLE CLASS, INT. CLS. 38
AND 42.

APEX INNOVATIONS INTELLECTUAL PROPERTIES, LA-
FAYETTE, LA:
4,014,974. PUB. 6-7-2011. INT. CL. 16.

API PARTNERS, LLC, BALA CYNWYD, PA:
4,017,223. INT. CL. 35.

APOLLO GROUP, INC., PHOENIX, AZ:
2,911,793. CANC. INT. CL. 41.

APOLLO LIGHT SYSTEMS, INC., AMERICAN FORK, UT:
2,911,462. CANC. INT. CL. 10.
2,911,463. CANC. INT. CL. 10.

APOLLOBRAVO INC., ALEXANDRIA, VA:
4,017,363. INT. CL. 35.

APPLIED AERONAUTICAL SYSTEMS, INC., MONTREAL,
QUEBEC, CANADA:
4,015,876. PUB. 6-7-2011. INT. CL. 9.

APPLY IN THE SKY, INC., SAN FRANCISCO, CA:
4,015,610. PUB. 6-7-2011. INT. CL. 42.

APPS GENIUS CORP., RED BANK, NJ:
4,015,746. PUB. 6-7-2011. INT. CL. 9.

APPSALUTE INC., SHELBYVILLE, KY:
2,909,843. CANC. INT. CL. 35.

AQUANOR MARKETING, INC., BOSTON, MA:
2,492,438. REN. 7-15-11. INT. CL. 29.
2,555,264. REN. 7-15-11. INT. CL. 29.

AQUARIAN, LLC, EDISON, NJ:
4,014,217. PUB. 6-7-2011. MULTIPLE CLASS, INT. CLS. 35
AND 42.

AQUAVATIONS CORP., MIAMI, FL:
2,461,335. REN. 7-19-11. INT. CL. 40.

AQUILA ENERGY CORPORATION, KANSAS CITY, MI:
2,909,400. CANC. INT. CL. 40.

AR SCIENTIFIC, INC., PHILADELPHIA, PA:
4,016,698. INT. CL. 5.

ARABIAN HORSE ASSOCIATION, AURORA, CO:
4,017,325. INT. CL. 41.

ARAG INSURANCE COMPANY, DES MOINES, IA:
4,016,856. INT. CL. 36.

ARAI HELMET AMERICAS, INC., DAYTONA, FL:
4,015,620. PUB. 6-7-2011. INT. CL. 9.

ARC IP LAW, PC, LA JOLLA, CA:
4,015,798. PUB. 6-7-2011. INT. CL. 45.
4,015,800. PUB. 6-7-2011. INT. CL. 45.

ARCELLA, CHRISTOPHER, OAKLAND, CA:
2,910,270. CANC. INT. CL. 41.

ARCHIMOVIL SYSTEM OF PUERTO RICO, INC., VILLA
FONTANA, CAROLINA, PUERTO RICO:
2,910,060. CANC. INT. CL. 20.

ARCHIMOVIL SYSTEMS OF PUERTO RICO, INC., VILLA
FONTANA, CAROLINA, PUERTO RICO:
2,910,061. CANC. INT. CL. 20.

ARCHITECTS SCHIPPER KASTNER, P.C., DES MOINES, IA,
DBA ASK STUDIO:
4,015,766. PUB. 6-7-2011. INT. CL. 42.

ARCTIC INNOVATIONS, ANCHORAGE, AK:
4,017,211. INT. CL. 21.

ARDRY TRADING CO., INC., RINCON, GA:
4,015,792. PUB. 6-7-2011. INT. CL. 7.

ARDUS MEDICAL, INC., CINCINNATI, OH:
2,470,228. REN. 7-21-11. INT. CL. 10.

AREA.CODES.UNPLUGGED, LLC, FAIRBURN, GA:
2,911,070. CANC. INT. CL. 25.
2,911,071. CANC. INT. CL. 25.

ARECONT VISION LLC, GLENDALE, CA:
4,017,316. INT. CL. 42.

ARENA SPORTS, INC., REDMOND, WA:
2,457,943. REN. 7-16-11. INT. CL. 41.

ARGUS MEDIA LIMITED, LONDON, UNITED KINGDOM:
3,659,756. COR. INT. CL. 9.

- ARISTA WINES, LLC, HEALDSBURG, CA:
4,014,239, PUB. 6-7-2011. INT. CL. 33.
- ARISTOCRAT TECHNOLOGIES AUSTRALIA PTY LTD.,
NORTH RYDE, NSW, AUSTRALIA:
3,960,942, COR. INT. CL. 9.
- ARISTOCRAT TECHNOLOGIES AUSTRALIA PTY LTD,
NORTH RYDE, NSW, AUSTRALIA:
4,016,297, INT. CL. 9.
- ARIZONA BOARD OF REGENTS, FOR AND ON BEHALF
OF ARIZONA STATE UNIVERSITY, TEMPE, AZ:
4,014,984, PUB. 6-7-2011. INT. CL. 41.
4,014,985, PUB. 6-7-2011. INT. CL. 41.
- ARIZONA CHAPTER NATIONAL SAFETY COUNCIL, INC.,
PHOENIX, AZ:
2,910,156, CANC. INT. CL. 41.
- ARIZONA LIVING LIGHT LLC, SCOTTSDALE, AZ:
4,016,774, INT. CL. 41.
- ARIZONA RANCH & RESORT CARS LLC, PRESCOTT
VALLEY, AZ:
2,910,724, CANC. INT. CL. 12.
- ARIZONA TILE, L.L.C., TEMPE, AZ:
2,506,469, REN. 7-16-11. INT. CL. 19.
2,519,482, REN. 7-21-11. INT. CL. 19.
- ARKANSAS TOURISM DEVELOPMENT FOUNDATION,
INC., LITTLE ROCK, AR:
4,015,170, PUB. 6-7-2011. INT. CL. 35.
- ARLINGTON SERVICES, INC., IRVING, TX:
4,014,206, PUB. 6-7-2011. MULTIPLE CLASS, INT. CLS. 29
AND 30.
- ARMI SPORT DI CHIAPPA SILVIA E C.SNC, VIA MILANO,
2, ITALY, DBA CHIAPPA FIREARMS:
4,014,720, PUB. 6-7-2011. INT. CL. 13.
- ARMISTEAD MECHANICAL, INC., WALDWICK, NJ:
4,014,945, PUB. 6-7-2011. MULTIPLE CLASS, INT. CLS. 37
AND 40.
4,014,992, PUB. 6-7-2011. MULTIPLE CLASS, INT. CLS. 37
AND 40.
- ARMITAGE INDUSTRIES, INC., FRANKLIN PARK, IL, IL,
DBA THERMAL-CHEM CORP.:
4,015,350, PUB. 6-7-2011. INT. CL. 2.
- ARMOR INTERNATIONAL S.A., BOGOTA, COLOMBIA:
4,014,311, PUB. 6-7-2011. MULTIPLE CLASS, INT. CLS. 6
AND 9.
- ARMOR INTERNATIONAL, LTD., WRENSHALL, MN:
2,910,792, CANC. MULTIPLE CLASS, INT. CLS. 4 AND 9.
- ARMSTRONG, RICHARD T., SAN DIEGO, CA:
2,910,962, CANC. INT. CL. 36.
- ARNOLD PALMER ENTERPRISES, INC., CLEVELAND,
OH:
4,017,142, INT. CL. 30.
- ARNOLD, CARTER, BEEVILLE, TX, DBA LEGACY OP-
TIONS AND ARNOLD, MARI, BEEVILLE, TX, DBA
LEGACY OPTIONS:
2,911,732, CANC. INT. CL. 41.
- ARNOLD'S RESTAURANT, INC., NORTH EASTHAM, MA:
2,910,969, CANC. INT. CL. 43.
- ARNOT + HALEY, PLLC, ETOWAH, NC:
4,017,297, INT. CL. 45.
- ARO WELDING TECHNOLOGIES, CHATEAU DU LOIR,
FRANCE:
1,163,417, REN. 7-20-11. INT. CL. 7.
- ARROW SEED CO., INC., BROKEN BOW, NE:
1,650,957, REN. 7-19-11. INT. CL. 31.
- ARROW-INTECHRA LLC, MELVILLE, NY:
2,909,893, CANC. INT. CL. 40.
- ARROWHEAD GLOBAL SOLUTIONS, INC., FALLS
CHURCH, VA:
2,911,419, CANC. MULTIPLE CLASS, INT. CLS. 37, 38
AND 42.
- ART HOUSE, LLC, BROOKLYN, NY, DBA ART HOUSE:
4,014,416, PUB. 6-7-2011. MULTIPLE CLASS, INT. CLS. 35
AND 41.
- ART MART, INC., ST. LOUIS, MO:
2,911,241, CANC. INT. CL. 35.
- ARTDECO COSMETIC GMBH, 85757 KARLSFELD, FED
REP GERMANY:
4,014,529, PUB. 6-7-2011. INT. CL. 9.
- ARTEZ INTERACTIVE INC., TORONTO, ONTARIO, CA-
NADA:
2,910,634, CANC. INT. CL. 42.
- ARTFUL INVENTIONS BY AREN IRWIN, LOS RANCHOS,
NM:
4,014,944, PUB. 6-7-2011. INT. CL. 20.
- ARTISTIC BEGINNINGS, LLC, NORTH YARMOUTH, ME:
2,911,248, CANC. INT. CL. 20.
2,911,249, CANC. INT. CL. 20.
- ARZU, INC., CHICAGO, IL:
4,015,745, PUB. 6-7-2011. INT. CL. 14.
- ASA SELECTION GMBH, FED REP GERMANY:
4,014,600, PUB. 6-7-2011. MULTIPLE CLASS, INT. CLS.
21, 24 AND 35.
- ASAHU BREWERIES, LTD., TOKYO, JAPAN:
2,910,304, CANC. MULTIPLE CLASS, INT. CLS. 1, 3, 5, 18,
21, 29, 30, 31, 32 AND 33.
- ASAHU GLASS COMPANY, LIMITED, CHIYODA-KU, TO-
KYO, JAPAN:
1,159,604, REN. 7-21-11. INT. CL. 1.
- ASBURY AUTOMOTIVE GROUP, INC., STAMFORD, CT:
2,910,237, CANC. INT. CL. 35.
- ASBURY PARK ZONE DEVELOPMENT CORP., ASBURY
PARK, NJ:
4,015,258, PUB. 6-7-2011. MULTIPLE CLASS, INT. CLS. 35
AND 41.
- ASCEND EAGLE, INC, AMERICAN CANYON, CA:
4,017,374, INT. CL. 10.
- ASCENSION ENTERTAINMENT, LOS ANGELES, CA:
2,910,832, CANC. MULTIPLE CLASS, INT. CLS. 4 AND 9.
- ASHANTI NICOLE HAMILTON, CHICAGO, IL, DBA
DEZTINNI BY ASHANTI-NICOLE:
4,015,164, PUB. 6-7-2011. INT. CL. 25.
- ASI BUSINESS SOLUTIONS, INC., KING OF PRUSSIA, PA:
2,484,126, REN. 7-16-11. INT. CL. 9.
- ASIA VITAL COMPONENTS CO., LTD., TAIPEI COUNTY
242, TAIWAN:
4,016,920, INT. CL. 7.
- ASK CHEMICALS GMBH, FED REP GERMANY:
4,014,512, PUB. 6-7-2011. INT. CL. 1.
4,014,576, PUB. 6-7-2011. INT. CL. 1.
- ASK THE TAX EXPERT, INC., ARVADA, CO:
2,911,173, CANC. INT. CL. 9.
- ASM LIQUOR PTY LTD, AUSTRALIA:
4,014,645, PUB. 6-7-2011. INT. CL. 33.
- ASPEX GROUP INC., TOWN OF MOUNT ROYAL, CANA-
DA:
4,015,940, PUB. 6-7-2011. INT. CL. 9.
- ASPYR MEDIA, INC., AUSTIN, TX:
2,910,363, CANC. INT. CL. 16.
- ASSET MANAGEMENT TECHNOLOGY SOLUTIONS, INC.,
BALTIMORE, MD:
2,909,819, CANC. INT. CL. 42.
- ASSOCIATED WHOLESALE GROCERS, INC., KANSAS
CITY, KS:
2,548,069, REN. 7-19-11. MULTIPLE CLASS, INT. CLS. 29
AND 30.
- ASSOCIATION FOR INDEPENDENT MANAGERS, INC., ST.
PETERSBURG, FL:
4,014,362, PUB. 6-7-2011. INT. CL. 35.
4,014,363, PUB. 6-7-2011. INT. CL. 35.
- ASSOCIATION OF INDEPENDENT OIL DISTRIBUTORS,
INC., MONTROSE, CO:
2,987,136, CANC. MULTIPLE CLASS, INT. CLS. 7 AND
21.
- ASSOCIATIONS, INC., DALLAS, TX:
4,016,465, INT. CL. 35.
- ASSOULINE, PROSPER, PARIS, FRANCE:
3,390,481, REN. 7-15-11. MULTIPLE CLASS, INT. CLS. 16,
35 AND 41.
- ASTOR HOME LTD., EAST RUTHERFORD, NJ:
4,016,656, INT. CL. 41.
- AT EASE TECHNOLOGIES, L.L.C., HOUSTON, TX:
2,911,144, CANC. INT. CL. 41.
- AT&T INTELLECTUAL PROPERTY II, L.P., RENO, NV:
2,911,615, CANC. INT. CL. 38.
2,911,651, CANC. INT. CL. 38.
2,911,780, CANC. INT. CL. 9.

ATALANTA CORPORATION, ELIZABETH, NJ:
 4,014,384, PUB. 6-7-2011. INT. CL. 35.
 ATEK PRODUCTS, LLC, BRAINERD, MN, ACROMETAL
 PRODUCTS, INC., MINNEAPOLIS, MN:
 536,432. REN. 7-16-11. U.S. CL. 2 (INT. CLS. 6 AND 7).
 ATG UV TECHNOLOGY LIMITED, UNITED KINGDOM:
 4,014,548, PUB. 6-7-2011. INT. CL. 11.
 4,014,549, PUB. 6-7-2011. INT. CL. 11.
 ATHENIAN ICE CREAM CO., INC., COMMACK, NY:
 2,411,718, CANC. INT. CL. 30.
 ATICO INTERNATIONAL USA, INC., FT. LAUDERDALE,
 FL:
 2,910,284, CANC. MULTIPLE CLASS, INT. CLS. 24 AND
 25.
 ATLANCO, INC., MARIETTA, GA:
 4,017,286, INT. CL. 9.
 ATLANTA DOG RUNNER, ATLANTA, GA:
 4,015,583, PUB. 6-7-2011. INT. CL. 44.
 ATLANTA TECHNOLOGY FORCE, INC., DULUTH, GA:
 4,015,465, PUB. 6-7-2011. INT. CL. 9.
 ATLANTA'S RELIABLE ROOFING CO., ATLANTA, GA,
 DBA RELIABLE ROOFING, INC.:
 4,015,634, PUB. 6-7-2011. INT. CL. 37.
 ATLANTIC BLOWERS, CARROLLTON, TX:
 4,015,019, PUB. 6-7-2011. INT. CL. 7.
 ATLAS COPCO CRAELIUS AB, SWEDEN:
 4,014,531, PUB. 6-7-2011. MULTIPLE CLASS, INT. CLS. 7
 AND 37.
 ATMEL CORPORATION, SAN JOSE, CA:
 2,911,820, CANC. INT. CL. 9.
 ATRINSIC, INC., NEW YORK, NY:
 4,015,379, PUB. 6-7-2011. MULTIPLE CLASS, INT. CLS. 35
 AND 42.
 ATX NETWORKS CORP., AJAX, ONTARIO, CANADA:
 4,014,816, PUB. 6-7-2011. INT. CL. 9.
 AU TECH CORP, HUNTLEY, IL:
 2,910,146, CANC. INT. CL. 28.
 AUBURN GLOBAL GROUP LLC, AUBURN HILLS, MI:
 4,016,440, INT. CL. 42.
 AUBURN INDUSTRIAL SERVICES LTD., BURLINGTON,
 ONTARIO, CANADA:
 2,910,444, CANC. INT. CL. 37.
 AUCTION.COM, LLC, IRVINE, CA:
 4,015,181, PUB. 6-7-2011. INT. CL. 35.
 AUDIENCESCIENCE INC., BELLEVUE, WA:
 4,015,747, PUB. 6-7-2011. MULTIPLE CLASS, INT. CLS.
 35, 38, 39 AND 42.
 AUGE, INC., NORTH PORT, FL:
 4,016,660, INT. CL. 25.
 4,016,661, INT. CL. 25.
 AUGEN OPTICOS, S.A. DE C.V., SAN DIEGO, CA:
 4,016,017, PUB. 6-7-2011. INT. CL. 9.
 AUGEO AFFINITY INSURANCE SERVICES, INC., ST.
 PAUL, MN:
 4,016,251, INT. CL. 36.
 AUGMENTED COMPUTER TECHNOLOGIES, INC., PALM
 HARBOR, FL:
 1,623,443. REN. 7-19-11. INT. CL. 9.
 AUGMENTIX CORPORATION, AUSTIN, TX:
 4,016,280, INT. CL. 9.
 AUI MANAGEMENT GROUP, INC., HENDERSON, NV:
 4,014,867, PUB. 6-7-2011. INT. CL. 35.
 AULBACH LIZENZ AG, CHUR, SWITZERLAND:
 4,016,190, INT. CL. 25.
 AULT, JANET M, SCOTTSDALE, AZ:
 4,017,167, INT. CL. 41.
 AURALEE PRODUCTIONS, INC., SEAFORD, NY:
 2,910,690, CANC. MULTIPLE CLASS, INT. CLS. 25 AND
 35.
 AURUM CERAMIC DENTAL LABORATORIES LTD., CAL-
 GARY, ALBERTA, CANADA:
 2,954,102, CANC. INT. CL. 5.
 AUSBURN, MARTIN, SEARCY, AR:
 4,015,031, PUB. 6-7-2011. INT. CL. 1.
 AUSTRALIAN RUGBY UNION LIMITED, ST. LEONARDS,
 NEW SOUTH WALES, AUSTRALIA:
 2,456,561. REN. 7-15-11. INT. CL. 25.
 AUTAM SOFTWARE PTY. LTD., KEWDALE, WA, AUS-
 TRALIA:
 2,910,727, CANC. INT. CL. 9.
 AUTOBOOK NOW LLC, WESTFIELD, IN:
 4,015,227, PUB. 6-7-2011. INT. CL. 35.
 AUTOHEROES, WALTHAM, MA:
 2,911,803, CANC. INT. CL. 35.
 AUTOIRA, LTD., HONG KONG, HONG KONG:
 2,412,972, CANC. INT. CL. 9.
 AUTOMATIC FILTERS, INC., LOS ANGELES, CA:
 4,017,061, INT. CL. 11.
 AUTOMATION DR. NIX GMBH, D-50739 KOLN, FED REP
 GERMANY:
 2,909,852, CANC. INT. CL. 9.
 AUTOMECHA, LTD, OXFORD, NY:
 2,910,729, CANC. INT. CL. 7.
 AUTOTRONIC CONTROLS CORPORATION, EL PASO, TX:
 2,909,719, CANC. MULTIPLE CLASS, INT. CLS. 7 AND
 37.
 AVALON VISION SOLUTIONS, LLC, LITHIA SPRINGS, GA:
 2,910,589, CANC. INT. CL. 9.
 AVANEX CORPORATION, FREMONT, CA:
 2,411,910, CANC. INT. CL. 9.
 2,411,911, CANC. INT. CL. 9.
 AVANTEC ZERSPANTECHNIK GMBH, 75428 ILLINGEN,
 FED REP GERMANY:
 4,014,568, PUB. 6-7-2011. INT. CL. 7.
 AVATAR SYSTEMS, INC., FRISCO, TX:
 2,458,998. REN. 7-21-11. INT. CL. 42.
 AVB, INC., MILWAUKIE, OR, DBA NATURE BAKE,
 NATURE'S STOREHOUSE, GRESHAM, OR:
 925,209. REN. 7-16-11. U.S. CL. 46 (INT. CL. 30).
 AVERY DENNISON RETAIL INFORMATION SERVICES,
 LLC, PASADENA, CA:
 2,484,368. REN. 7-19-11. INT. CL. 8.
 AVID TECHNOLOGY, INC., TEWKSBURY, DE:
 2,909,508, CANC. INT. CL. 9.
 AVIDASTRA, INC., BOISE, ID:
 2,910,603, CANC. MULTIPLE CLASS, INT. CLS. 36 AND
 37.
 AVIQUEST TECHNOLOGY CORPORATION, LTD.,
 HSINCHU, TAIWAN:
 2,910,138, CANC. INT. CL. 42.
 AVOCENT HUNTSVILLE CORP., HUNTSVILLE, AL:
 2,458,728. REN. 7-16-11. INT. CL. 9.
 2,458,728, AM. INT. CL. 9.
 AVON PRODUCTS, INC., NEW YORK, NY:
 2,910,144, CANC. INT. CL. 5.
 3,140,276, CANC. INT. CL. 3.
 AWB RISKASSIST LIMITED, MELBOURNE, AUSTRALIA:
 3,141,850, CANC. MULTIPLE CLASS, INT. CLS. 16, 35
 AND 36.
 AWESOME KIDS, LLC, WHEATON, IL:
 2,911,744, CANC. INT. CL. 25.
 2,911,745, CANC. INT. CL. 25.
 2,911,746, CANC. INT. CL. 14.
 2,911,747, CANC. INT. CL. 14.
 2,911,748, CANC. INT. CL. 3.
 2,911,751, CANC. INT. CL. 9.
 2,911,752, CANC. INT. CL. 41.
 2,911,753, CANC. INT. CL. 28.
 2,911,754, CANC. INT. CL. 9.
 2,911,756, CANC. INT. CL. 14.
 2,911,762, CANC. INT. CL. 25.
 2,911,763, CANC. INT. CL. 41.
 2,911,765, CANC. INT. CL. 6.
 2,911,766, CANC. INT. CL. 18.
 2,911,767, CANC. INT. CL. 24.
 2,911,768, CANC. INT. CL. 28.
 2,911,773, CANC. INT. CL. 14.
 2,911,774, CANC. INT. CL. 25.
 2,911,775, CANC. INT. CL. 41.
 2,911,776, CANC. INT. CL. 28.
 AWESOME PRODUCTS, INC., BUENA PARK, CA:
 4,016,640, INT. CL. 3.
 AWI LICENSING COMPANY, WILMINGTON, DE:
 2,909,720, CANC. INT. CL. 19.
 2,909,792, CANC. INT. CL. 27.

- AXA EQUITABLE LIFE INSURANCE COMPANY, NEW YORK, NY:
4,017,204, INT. CL. 36.
- AXARON BIOSCIENCE AG, HEIDELBERG, FED REP GERMANY:
2,910,731, CANC. MULTIPLE CLASS, INT. CLS. 42 AND 44.
- AXEL SPRINGER AG, 10888 BERLIN, FED REP GERMANY:
2,427,751, REN. 7-15-11, MULTIPLE CLASS, INT. CLS. 16 AND 42.
- AXIAL BIOTECH, INC., SALT LAKE CITY, UT:
3,909,359, COR. MULTIPLE CLASS, INT. CLS. 16 AND 20.
3,921,142, COR. INT. CL. 25.
- AXN HEAVY DUTY, LLC, GOSHEN, KY:
4,016,492, INT. CL. 12.
- AXTELL EXPRESSIONS, INC., VENTURA, CA:
2,910,262, CANC. INT. CL. 28.
- AXWAY SOFTWARE, ANNECY LE VIEUX, FRANCE:
3,491,038, CANC. MULTIPLE CLASS, INT. CLS. 9 AND 38.
- AYALA, HANA, IRVINE, CA:
4,015,485, PUB. 6-7-2011, INT. CL. 35.
4,015,563, PUB. 6-7-2011, INT. CL. 43.
- AZAR DISTILLING, LLC, SAN ANTONIO, TX:
4,017,342, INT. CL. 33.
- AZER, STEVEN B., SPRING VALLEY, CA:
4,015,630, PUB. 6-7-2011, INT. CL. 41.
- AZIMUTH INTERACTIVE, INC., PEEKSKILL, NY:
2,411,886, CANC. INT. CL. 9.
- AZULEV, S.A., ONDA (CASTELLON), SPAIN:
2,910,499, CANC. INT. CL. 19.
- A1 PRICE ENTERPRISES ("A1 PRICE"), CINCINNATI, OH:
4,014,202, PUB. 6-7-2011, INT. CL. 6.
- B & N PRODUCTIONS, LLC, LIBERTY TOWNSHIP, OH:
2,910,635, CANC. INT. CL. 41.
- B HOTEL GROUP, LLC, WESTON, FL:
4,016,431, INT. CL. 43.
4,016,432, INT. CL. 43.
- B(R)AND MATTER, LLC, NEW YORK, NY:
4,016,218, INT. CL. 25.
- B-CYCLE LLC, WATERLOO, WI:
4,016,807, MULTIPLE CLASS, INT. CLS. 35 AND 39.
- BABCOCK PARTNERS, LLC, BATON ROUGE, LA:
4,016,928, INT. CL. 45.
- BACARDI & COMPANY LIMITED, VADUZ FL-9490, LIECHTENSTEIN:
4,017,240, INT. CL. 33.
- BACK TO AFRICA CORP., BROOKLYN, NY:
4,017,104, INT. CL. 3.
- BADGER SPORTSWEAR, STATESVILLE, NC:
4,015,645, PUB. 6-7-2011, INT. CL. 25.
- BADGER SPORTSWEAR, STATESVILLE, NC:
4,016,083, PUB. 6-7-2011, INT. CL. 25.
4,016,084, PUB. 6-7-2011, INT. CL. 25.
4,016,085, PUB. 6-7-2011, INT. CL. 25.
- BAEBLER, DREW, C., ST. LOUIS, MO, DBA THE GREEN CERTIFICATION CORPORATION:
4,016,309, INT. CL. 42.
- BAEK, STEVEN, LA HABRA HEIGHTS, CA:
4,016,718, INT. CL. 25.
- BAIT RIGS TACKLE COMPANY, MADISON, WI:
2,910,668, CANC. INT. CL. 28.
- BAKER HUGHES INCORPORATED, HOUSTON, TX:
2,911,084, CANC. INT. CL. 7.
- BAKER STREET PUBLISHING, LLC, SAN FRANCISCO, CA:
4,016,609, MULTIPLE CLASS, INT. CLS. 9, 35 AND 41.
- BAKERS DELIGHT HOLDINGS LTD., CAMBERWELL, VICTORIA, 3124, AUSTRALIA:
2,956,022, CANC. MULTIPLE CLASS, INT. CLS. 35 AND 43.
2,956,023, CANC. MULTIPLE CLASS, INT. CLS. 35 AND 43.
- BAKERY, CONFECTIONERY, TOBACCO WORKERS AND GRAIN MILLERS INTERNATIONAL UNION, KENSINGTON, MD:
2,473,249, REN. 7-19-11, U.S. CL. 200.
- BALCONES DISTILLING LLC, WACO, TX, DBA BALCONES DISTILLING:
4,016,371, INT. CL. 33.
- BALDWIN PARK FROYO LLC, LONGWOOD, FL, DBA DELISH FROZEN YOGURT:
4,017,324, INT. CL. 43.
- BALTIMORE LIFE INSURANCE COMPANY, THE, OWINGS MILLS, MD:
2,411,694, CANC. INT. CL. 36.
- BAMA RAGS, INC., CHARLOTTESVILLE, VA:
4,015,418, PUB. 6-7-2011, INT. CL. 9.
4,015,419, PUB. 6-7-2011, INT. CL. 9.
- BAMBOO SOLUTIONS CORPORATION, RESTON, VA:
4,017,054, INT. CL. 42.
- BANK OF AMERICA CORPORATION, CHARLOTTE, NC:
2,909,524, CANC. INT. CL. 36.
2,909,746, CANC. INT. CL. 36.
2,909,864, CANC. MULTIPLE CLASS, INT. CLS. 16 AND 41.
4,014,361, PUB. 6-7-2011, INT. CL. 36.
- BANKERS ADVOCATE GROUP LLC, JUPITER, FL:
4,015,176, PUB. 6-7-2011, INT. CL. 36.
- BANKRATE, INC, NORTH PALM BEACH, FL:
2,411,942, CANC. INT. CL. 36.
- BARAK, AMNON, JERUSALEM 93708, ISRAEL AND SHILOH, AMNON, CAMPBELLTOWN, SOUTH AUSTRALIA 5074, AUSTRALIA:
2,758,282, CANC. INT. CL. 9.
- BARAMARO, LLC, CHICAGO, IL:
4,017,171, INT. CL. 43.
- BARBARA'S CONFECTIONS LLC, MADISON, NJ:
4,017,200, INT. CL. 30.
- BARBOUR ENERGY CORPORATION, OKLAHOMA CITY, OK:
4,016,265, MULTIPLE CLASS, INT. CLS. 40 AND 42.
- BARE HEART BUDDY, LLC, HENDERSON, NV:
4,017,111, INT. CL. 28.
- BARELE, INC., BROOKLYN, NY:
2,910,755, CANC. INT. CL. 44.
- BARGERSTOCK, ANDREW S., FAIRFIELD, IA:
4,015,869, PUB. 6-7-2011, INT. CL. 41.
- BARNES CORNERS SNO-PALS INC., RODMAN, NY:
4,015,924, PUB. 6-7-2011, MULTIPLE CLASS, INT. CLS. 25 AND 41.
- BARNES, NINA, E. HAMPTON, NY:
2,413,197, CANC. INT. CL. 3.
- BARNETT OUTDOORS, LLC, TARPON SPRINGS, FL:
4,016,599, INT. CL. 28.
- BARON INTERNATIONAL TRADING LTD., OR YEHUDA, ISRAEL:
4,014,790, PUB. 6-7-2011, MULTIPLE CLASS, INT. CLS. 29 AND 30.
- BARONA GROUP OF THE CAPITAN GRANDE BAND OF MISSION INDIANS, LAKESIDE, CA, DBA BARONA VALLEY RANCH RESORT AND CASINO:
4,014,926, PUB. 6-7-2011, INT. CL. 41.
4,014,927, PUB. 6-7-2011, INT. CL. 41.
4,014,928, PUB. 6-7-2011, INT. CL. 41.
4,014,929, PUB. 6-7-2011, INT. CL. 41.
- BARR LABORATORIES, INC., WOODCLIFF LAKE, NJ:
2,457,653, REN. 7-16-11, INT. CL. 5.
- BARR LABORATORIES, INC., POMONA, NY:
2,910,088, CANC. INT. CL. 5.
- BARRATT, BARNABY B., FARMINGTON HILLS, MI:
2,909,707, CANC. INT. CL. 41.
- BARRETT, JOHN BENJAMIN, LOS ANGELES, CA:
4,016,393, INT. CL. 41.
- BARTCORP, INC., TULSA, OK:
2,910,067, CANC. INT. CL. 41.
- BARTES, BRIAN, PLYMOUTH, MI:
2,910,961, CANC. INT. CL. 41.
- BARTO, ROBERT, BROOKLYN, NY, DBA ROCK BOYS:
4,014,696, PUB. 6-7-2011, INT. CL. 24.
- BASEMENT FLOOD PROTECTOR, LAKE ZURICH, IL:
4,014,758, PUB. 6-7-2011, INT. CL. 37.
- BASF SE., LUDWIGSHAFEN AM (RHEIN), FED REP GERMANY:
718,394, REN. 7-18-11, U.S. CL. 1 (INT. CL. 1).

BASS PRO INTELLECTUAL PROPERTY, L.L.C., SPRINGFIELD, MO:
4,016,733, INT. CL. 43.

BATESVILLE SERVICES, INC., BATESVILLE, IN:
4,016,466, INT. CL. 20.

BATH & BODY WORKS BRAND MANAGEMENT, INC., REYNOLDSBURG, OH:
4,016,855, MULTIPLE CLASS, INT. CLS. 3 AND 4.
4,016,876, INT. CL. 11.
4,016,950, INT. CL. 3.
4,016,951, MULTIPLE CLASS, INT. CLS. 3 AND 5.

BATTERED WOMEN'S ALTERNATIVES, INC., CONCORD, CA:
2,552,204, CANC. INT. CL. 42.

BAUER BROTHERS, OCEANSIDE, CA:
2,910,893, CANC. INT. CL. 25.
2,910,899, CANC. INT. CL. 25.

BAUER NIKE HOCKEY INC., MONTREAL, QUEBEC, CANADA TO NIKE BAUER HOCKEY U.S.A., INC., GREENLAND, NH:
2,431,885, CANC. MULTIPLE CLASS, INT. CLS. 9 AND 28.

BAUSCH & LOMB INCORPORATED, ROCHESTER, NY:
4,014,938, PUB. 6-7-2011. INT. CL. 10.

BAXTER INTERNATIONAL INC., DEERFIELD, IL, CAMPBELL PHARMACEUTICALS, INC., NEW YORK, NY:
717,121. REN. 7-18-11. U.S. CL. 18 (INT. CL. 5).

BAXTER INTERNATIONAL INC., DEERFIELD, IL:
2,412,837, CANC. INT. CL. 10.

BAY CITY TELEVISION, INC., SAN DIEGO, CA:
4,014,297, PUB. 6-7-2011. INT. CL. 41.

BAY ISLAND SPORTSWEAR, GREENWOOD, SC:
4,014,208, PUB. 6-7-2011. INT. CL. 25.

BAY RIDGE AUTOMOTIVE MANAGEMENT CORP., BROOKLYN, NY:
2,476,229. REN. 7-16-11. INT. CL. 37.
2,476,229, CANC. INT. CL. 39.

BAYER AKTIENGESELLSCHAFT, 51373 LEVERKUSEN, FED REP GERMANY:
2,911,012, CANC. MULTIPLE CLASS, INT. CLS. 1 AND 5.
2,911,020, CANC. MULTIPLE CLASS, INT. CLS. 1 AND 5.

BAYER MATERIALSCIENCE LLC, PITTSBURGH, PA, MO-BAY CHEMICAL COMPANY, PITTSBURGH, PA:
720,513. REN. 7-15-11. U.S. CL. 1 (INT. CL. 1).

BAYERISCHE MOTOREN WERKE AKTIENGESELLSCHAFT, 80809 MUNICH, FED REP GERMANY:
2,909,634, CANC. INT. CL. 12.
2,909,922, CANC. INT. CL. 12.
2,909,923, CANC. INT. CL. 12.
2,909,925, CANC. INT. CL. 12.
2,909,927, CANC. INT. CL. 12.

BAZZOLI FRANCO, PAVIA, ITALY:
4,014,480, PUB. 6-7-2011. MULTIPLE CLASS, INT. CLS. 35 AND 43.

BB-KAPITALBETEILIGUNGSGESELLSCHAFT MBH, BERLIN, FED REP GERMANY:
2,911,364, CANC. INT. CL. 36.

BBY SOLUTIONS, INC., RICHFIELD, MN:
2,910,659, CANC. INT. CL. 35.

BC MARKETING SOLUTIONS, NEW YORK, NY:
2,910,894, CANC. INT. CL. 9.

BCI COMMUNICATIONS, INC., ELMWOOD PARK, NJ:
4,014,725, PUB. 6-7-2011. INT. CL. 37.

BD PERFORMING ARTS, CONCORD, CA:
4,014,814, PUB. 6-7-2011. INT. CL. 35.

BDFFL ENTERPRISES, LLC, CHARLOTTE, MI:
4,016,639, INT. CL. 28.

BE TRUE TO YOU COACHING LLC, ROSWELL, GA:
4,015,459, PUB. 6-7-2011. INT. CL. 41.

BEACH COMMUNICATIONS, PLEASANT RIDGE, MI:
2,911,706, CANC. INT. CL. 35.
2,911,707, CANC. INT. CL. 35.

BEACON WELLNESS ADVISORS LLC, WATCHUNG, NJ:
4,016,476, MULTIPLE CLASS, INT. CLS. 41 AND 44.

BEAU BRONZ LIMITED, LONDON, SW15 1SR, UNITED KINGDOM:
4,016,884, INT. CL. 3.

BEAULIEU GROUP, LLC, DALTON, GA:
2,911,344, CANC. INT. CL. 27.

BEAUMONT RUNNER TECHNOLOGIES, INC., ERIE, PA:
4,014,406, PUB. 6-7-2011. INT. CL. 40.

BEAUTE CREATEURS (SOCIETE ANONYME), PARIS, FRANCE:
2,910,588, CANC. MULTIPLE CLASS, INT. CLS. 3 AND 5.

BEAUTY COSMETICA, CORP., MIAMI, FL:
4,015,801, PUB. 6-7-2011. INT. CL. 3.

BEAUTY HOLDING LLC, DENTON, TX:
2,412,858, CANC. INT. CL. 3.

BEAZER HOMES HOLDINGS CORP., ATLANTA, GA:
2,957,786, CANC. INT. CL. 36.

BECTON, DICKINSON AND COMPANY, FRANKLIN LAKES, NJ:
1,635,189. REN. 7-21-11. INT. CL. 1.

BED BUG 911 CORP., BROOKLYN, NY:
4,015,292, PUB. 6-7-2011. INT. CL. 37.

BEDFORD STUYVESANT COLLEGIATE CHARTER SCHOOL, BROOKLYN, NY:
4,015,319, PUB. 6-7-2011. INT. CL. 41.

BEELE ENGINEERING B.V., NETHERLANDS:
4,014,601, PUB. 6-7-2011. INT. CL. 1.

BEHR PROCESS CORPORATION, SANTA ANA, CA:
4,017,249, INT. CL. 41.

BEIERSDORF AKTIENGESELLSCHAFT, 20245 HAMBURG, FED REP GERMANY:
2,492,030. REN. 7-18-11. INT. CL. 3.

BEIJING AJHX HELMET TECHNOLOGY & TRADE CO., LTD., BEIJING, CHINA:
4,015,928, PUB. 6-7-2011. INT. CL. 9.

BEIJING BRIGHTCAST CO., LTD., CHINA:
4,014,582, PUB. 6-7-2011. MULTIPLE CLASS, INT. CLS. 9 AND 11.

BEIJING UPLOOKING TECHNOLOGY CO., LTD., HAI-DIAN DIS., BEIJING, CHINA:
4,016,816, INT. CL. 42.

BELCORP OF AMERICA INC, MIAMI, FL:
2,910,939, CANC. INT. CL. 34.

BELLEVUE PLACE OFFICE BUILDING 1 LIMITED PARTNERSHIP, BELLEVUE, WA:
2,468,974. REN. 7-16-11. MULTIPLE CLASS, INT. CLS. 36 AND 37.

BELVOIR FEDERAL CREDIT UNION, WOODBRIDGE, VA:
4,014,942, PUB. 6-7-2011. INT. CL. 36.

BEM FRANCHISING, INC., LONG BEACH, CA:
2,910,902, CANC. INT. CL. 9.

BENEFICIO CUSTEPEC, S.A. DE C.V., 30360 CHIAPAS, MEXICO:
2,909,390, CANC. INT. CL. 30.

BENSON AND CURTIS CORP., PASADENA, CA:
4,017,312, INT. CL. 37.

BERG, MATTHEW L, GARLAND, TX, DBA TAPULAR AND WALKER, ROBERT B, GARLAND, TX, DBA TAPULAR:
4,015,685, PUB. 6-7-2011. INT. CL. 9.

BERGHAUSEN CORPORATION, CINCINNATI, OH:
4,017,108, INT. CL. 32.

BERMAN, JOANN, NEW YORK, NY:
2,909,986, CANC. INT. CL. 41.

BERNARD SCHUMACHER, BISMARCK, ND:
4,016,608, INT. CL. 35.

BERNS, MARVIN, TORONTO, ONTARIO, CANADA:
4,014,304, PUB. 10-5-2010. INT. CL. 44.

BEROL CORPORATION, FREEPORT, IL:
2,911,673, CANC. INT. CL. 16.

BERRY PLASTICS CORPORATION, EVANSVILLE, IN:
4,016,436, INT. CL. 21.

BERTCH CABINET MFG., INC., WATERLOO, IA:
2,910,071, CANC. INT. CL. 20.
2,910,072, CANC. INT. CL. 20.

BEST MEDICAL INTERNATIONAL, INC., SPRINGFIELD, VA:
2,412,776, CANC. INT. CL. 10.

BEST PUBLICATIONS, LLP, AMARILLO, TX:
2,911,389, CANC. INT. CL. 16.

BET.COM, LLC, WASHINGTON, DC:
2,721,758, CANC. INT. CL. 41.

- BETMEX, LLC, KODAK, TN:
2,911,309, CANC. INT. CL. 43.
- BETTER METAL, LLC, LA VERGNE, TN:
4,016,756, INT. CL. 20.
- BETTER WORLD ENTERPRISES, INC., FORT COLLINS,
CO, DBA YOUR TRUE NATURE, INC.:
4,015,706, PUB. 6-7-2011. INT. CL. 45.
- BEVAN, ABBY H., CHARLOTTE, NC:
2,910,806, CANC. INT. CL. 25.
- BEVERLY KAYE & ASSOCIATES, INC., SCRANTON, PA,
DBA CAREER SYSTEMS INTERNATIONAL:
3,962,600, COR. MULTIPLE CLASS, INT. CLS. 16 AND
35.
- BEYOND ALL EXPECTATIONS, INC., NOVATO, JAMES;
RODNEY D., SAN FRANCISCO, CA AND SMITH, LORI,
SAN FRANCISCO, CA:
1,159,634, REN. 7-18-11. INT. CL. 3.
- BEYOND CATEGORY LLC, NEW YORK, NY:
4,017,098, INT. CL. 9.
- BEYONDTRUST SOFTWARE, INC., AGOURA HILLS, CA:
4,016,739, INT. CL. 9.
4,016,740, INT. CL. 9.
4,016,741, INT. CL. 9.
4,016,742, INT. CL. 9.
4,016,744, INT. CL. 9.
- BIALETTI INDUSTRIE S.P.A., OMEGNA, ITALY:
2,910,418, CANC. INT. CL. 21.
- BICOM, INC., MONROE, CT, DBA ZÖET:
4,016,983, INT. CL. 9.
- BIDRIVALS INC., NEW YORK, NY:
4,014,401, PUB. 6-7-2011. INT. CL. 35.
- BIG BOOM BRANDS, LLC, WEST PALM BEACH, FL:
2,911,080, CANC. INT. CL. 5.
- BIG BOTTOM DISTILLING, LLC, PORTLAND, OR, DBA
BIG BOTTOM WHISKEY:
4,016,042, PUB. 6-7-2011. INT. CL. 33.
- BIG DOG MOTORCYCLES LLC, WICHITA, KS:
2,910,630, CANC. INT. CL. 12.
- BIG FISH GAMES, INC., SEATTLE, WA:
4,015,977, PUB. 6-7-2011. INT. CL. 41.
- BIG PUBLISHING LIMITED, LONDON, UNITED KING-
DOM:
2,909,583, CANC. INT. CL. 35.
- BIG SKY BRANDS, TORONTO, ONTARIO, CANADA:
2,413,220, CANC. INT. CL. 30.
2,413,221, CANC. INT. CL. 30.
- BIG Y FOODS, INC., SPRINGFIELD, MA:
2,910,562, CANC. INT. CL. 41.
- BIGELOW MERCHANDISING, LLC, COLUMBUS, OH:
3,636,961, COR. MULTIPLE CLASS, INT. CLS. 3, 5, 8, 30,
35 AND 45.
3,641,355, COR. MULTIPLE CLASS, INT. CLS. 3 AND 5.
- BILL BLASS GROUP, LLC, NEW YORK, NY:
2,910,935, CANC. INT. CL. 25.
- BILL ME, INC., NEW YORK, NY:
2,911,474, CANC. INT. CL. 25.
- BIMBA MANUFACTURING COMPANY, MONEE, IL:
4,015,208, PUB. 6-7-2011. INT. CL. 7.
- BIMEDA INC., OAKBROOK TERRACE, IL:
2,458,931, REN. 7-15-11. INT. CL. 5.
- BINNEY & SMITH LLC, EASTON, PA:
1,157,296, REN. 7-19-11. INT. CL. 16.
1,163,721, REN. 7-18-11. INT. CL. 16.
- BIO CAPITAL SAS, FRANCE:
4,014,570, PUB. 6-7-2011. MULTIPLE CLASS, INT. CLS.
35, 36, 37, 38, 39, 40, 41, 42 AND 43.
4,014,571, PUB. 6-7-2011. MULTIPLE CLASS, INT. CLS.
35, 36, 37, 38, 39, 40, 41, 42 AND 43.
- BIO CYBERNETICS INTERNATIONAL, LA VERNE, CA:
4,014,256, PUB. 6-7-2011. INT. CL. 10.
- BIO HUMA NETICS, INC., CHANDLER, AZ:
2,478,962, REN. 7-19-11. INT. CL. 1.
- BIO PAC, INC., INCLINE VILLAGE, NV:
4,015,257, PUB. 6-7-2011. INT. CL. 2.
- BIO-LOK INTERNATIONAL, INC., DEERFIELD BEACH,
FL:
2,465,070, REN. 7-18-11. INT. CL. 10.
- BIO-VET, INC., BLUE MOUNDS, WI:
4,015,980, PUB. 6-7-2011. INT. CL. 5.
- BIOCATALYSTS LIMITED, CARDIFF, UNITED KINGDOM:
4,015,001, PUB. 6-7-2011. INT. CL. 1.
- BIOCISION, LLC, MILL VALLEY, CA:
4,015,776, PUB. 6-7-2011. INT. CL. 9.
- BIOCLINICA, INC., NEWTON, PA:
2,909,525, CANC. INT. CL. 42.
- BIOFARMA (SOCIETE PAR ACTIONS SIMPLIFIEE), 92200
NUEILLY-SUR-SEINE, FRANCE:
2,910,279, CANC. INT. CL. 42.
- BIOLOGISCHE HEILMITTEL HEEL GMBH, BADEN-BA-
DEN D-7570, FED REP GERMANY:
4,015,035, PUB. 6-7-2011. INT. CL. 5.
- BIOLOGIX SYSTEMS CORPORATION, SAINT LOUIS, MO:
2,909,715, CANC. INT. CL. 1.
- BIOMED REALTY TRUST, INC., SAN DIEGO, CA:
4,016,832, MULTIPLE CLASS, INT. CLS. 36 AND 37.
4,016,833, MULTIPLE CLASS, INT. CLS. 36 AND 37.
- BIOMEDICOM CREATIVE BIOMEDICAL COMPUTING
LTD., JERUSALEM, ISRAEL:
2,604,385, CANC. INT. CL. 10.
- BIONAN HEALTHCARE, INC., PORT ST. LUCIE, FL:
4,016,887, MULTIPLE CLASS, INT. CLS. 5 AND 42.
- BIONESS INC., VALENCIA, CA:
2,909,803, CANC. INT. CL. 10.
- BIOPLATE, INC., LOS ANGELES, CA:
2,461,108, REN. 7-20-11. INT. CL. 10.
- BIOSELECT, INC., CHARLOTTE, NC:
4,016,046, PUB. 6-7-2011. INT. CL. 42.
- BIOSTIME, INC. (GUANGZHOU), GUANGZHOU, GUANG-
DONG, CHINA:
4,014,705, PUB. 3-1-2011. INT. CL. 21.
4,014,707, PUB. 3-1-2011. INT. CL. 30.
4,014,708, PUB. 3-1-2011. INT. CL. 41.
- BIOSTIME, INC. (GUANGZHOU), GUANGZHOU, GUANG-
DONG, CHINA:
4,014,706, PUB. 3-1-2011. INT. CL. 29.
4,014,709, PUB. 3-1-2011. INT. CL. 42.
- BIOTECH INTERNATIONAL CORPORATION, GLASTON-
BURY, CT, DBA BIOTECH CORPORATION:
2,411,711, CANC. INT. CL. 5.
- BIOTECHPLEX CORPORATION, ELK GROVE VILLAGE,
IL:
2,911,436, CANC. INT. CL. 10.
- BIOTEPP INC., CHARLESBOURG, QUEBEC, CANADA:
2,500,136, REN. 7-20-11. INT. CL. 5.
- BIRTHMOTHER MINISTRIES, INC., VIENNA, VA:
2,497,093, REN. 7-21-11. INT. CL. 16.
- BISHOP-GEORGE ENTERPRISES, INC., KILDEER, IL:
2,910,076, CANC. INT. CL. 16.
- BISHOP, KENNETH B., HERMOSA BEACH, CA AND
BISHOP, KJERSTI K., HERMOSA BEACH, CA:
4,016,374, INT. CL. 42.
- BISSELL HOMECARE, INC., GRAND RAPIDS, MI:
4,017,213, INT. CL. 3.
- BITTER CREEK CANDLE SUPPLY INC., ASHLAND, WI,
BITTER CREEK CANDLE SUPPLY INC., ASHLAND, WI:
2,472,067, REN. 7-19-11. INT. CL. 1.
- BIVENS, CONNIE, UPLAND, CA AND BIVENS, JON, UP-
LAND, CA, DBA SPORT PINS INTERNATIONAL, INC.:
1,651,184, REN. 7-18-11. INT. CL. 18.
- BIZZNESSCARD LLC, SCOTTSDALE, AZ:
4,017,384, MULTIPLE CLASS, INT. CLS. 35 AND 42.
- BJ&J, LTD., BOULDER, CO:
2,911,316, CANC. INT. CL. 14.
- BK SALES GROUP, INC., NORTH MIAMI BEACH, FL:
2,910,089, CANC. INT. CL. 25.
- BLACK ACHIEVEMENT CORPORATION, EASTON, PA:
2,162,395, CANC. INT. CL. 16.
- BLACK ICE OUTDOOR PRODUCTIONS, LLC, BRULE, WI:
4,015,941, PUB. 6-7-2011. INT. CL. 41.
- BLACK SWAN YOGA, LLC, AUSTIN, TX:
4,015,949, PUB. 6-7-2011. INT. CL. 41.
- BLACKBAG TECHNOLOGIES, INC., SANTA CLARA, CA:
2,910,851, CANC. MULTIPLE CLASS, INT. CLS. 9 AND
42.

BLADERUNNER FARMS, INC., POTEET, TX:
4,016,188, INT. CL. 31.

BLAIN SUPPLY, INC., JANESVILLE, WI:
2,490,918, REN. 7-19-11. INT. CL. 8.

BLAKE PUBLISHING PTY LTD, NEW SOUTH WALES, AUSTRALIA:
4,014,777, PUB. 6-7-2011. MULTIPLE CLASS, INT. CLS. 9, 16 AND 41.
4,014,778, PUB. 6-7-2011. MULTIPLE CLASS, INT. CLS. 9, 16 AND 41.

BLAKE, JULIE K., SPRINGFIELD, MA AND BLAKE, STEPHEN D., SPRINGFIELD, MA:
2,910,559, CANC. INT. CL. 41.

BLANC, KATHERINE L., SANTA MONICA, CA:
2,910,642, CANC. INT. CL. 16.

BLANCHARD TRAINING AND DEVELOPMENT, INC., ESCONDIDO, CA:
2,473,089, REN. 7-20-11. INT. CL. 16.

BLENDED BITS, LLC, ATLANTA, GA:
4,015,568, PUB. 6-7-2011. INT. CL. 42.

BLIER, BARRY J., WARWICK, RI, DBA CUPIDON PRODUCTIONS:
2,543,417, REN. 7-21-11. INT. CL. 41.

BLINK HOLDINGS, INC., NEW YORK, NY:
4,016,817, INT. CL. 41.

BLINKMIND, INC., KATY, TX:
3,863,007, AM. INT. CL. 38.
3,875,818, AM. INT. CL. 38.

BLOCKER, DEMETRIUS L, HENDERSON, NV, DBA LOVE-CHANGESTHINGS.COM:
4,015,386, PUB. 6-7-2011. INT. CL. 25.

BLONDHEIM, BRAD, LOS ANGELES, CA:
2,905,364, CANC. INT. CL. 41.

BLOUNT, INC., PORTLAND, OR:
4,017,051, INT. CL. 7.

BLUE CLOUD COMMUNICATIONS, INC., RED BANK, NJ:
4,015,416, PUB. 6-7-2011. MULTIPLE CLASS, INT. CLS. 35 AND 42.

BLUE GRASS CUTLERY, MANCHESTER, OH:
4,016,726, INT. CL. 8.

BLUE HAWAII LIFESTYLE, LLC, HONOLULU, HI:
4,015,547, PUB. 6-7-2011. MULTIPLE CLASS, INT. CLS. 25, 35 AND 43.

BLUE IVY LLC, STURGEON BAY, WI:
4,015,486, PUB. 6-7-2011. INT. CL. 35.

BLUE RIBBON IP, LLC, NEW YORK, NY:
4,016,561, INT. CL. 29.

BLUE SKY NATURAL BEVERAGE COMPANY, CORONA, CA:
2,510,956, REN. 7-16-11. INT. CL. 32.

BLUE SKY THE COLOR OF IMAGINATION, LLC, NEWPORT BEACH, CA:
2,909,981, CANC. MULTIPLE CLASS, INT. CLS. 16 AND 18.

BLUE STAR JETS, LLC, NEW YORK, NY:
2,910,624, CANC. INT. CL. 39.

BLUESCAPE, INC., SAN DIEGO, CA:
2,910,566, CANC. INT. CL. 42.

BLUESTEM BRANDS, INC., EDEN PRAIRIE, MN:
4,017,087, INT. CL. 35.

BLUMENTHAL DISTRIBUTING, INC., ONTARIO, CA, DBA OFFICE STAR PRODUCTS:
3,047,739, COR. INT. CL. 24.

BMC SOFTWARE, INC., HOUSTON, TX:
2,458,178, REN. 7-16-11. INT. CL. 9.

BMGM CO., L.L.C., NEW YORK, NY:
4,014,201, PUB. 6-7-2011. INT. CL. 25.

BNP MEDIA II, LLC, TROY, MI:
4,017,313, MULTIPLE CLASS, INT. CLS. 35 AND 41.

BOARD OF REGENTS OF THE UNIVERSITY SYSTEM OF GEORGIA, ATLANTA, GA:
4,016,133, PUB. 6-7-2011. INT. CL. 41.
4,016,134, PUB. 6-7-2011. MULTIPLE CLASS, INT. CLS. 9 AND 41.

BOAS GROUP, INC., THE, ATLANTA, GA:
4,016,834, MULTIPLE CLASS, INT. CLS. 16 AND 41.

BOASTING BIZ, INC., FORT LAUDERDALE, FL:
4,015,075, PUB. 6-7-2011. MULTIPLE CLASS, INT. CLS. 35 AND 42.

BOB JONES UNIVERSITY, INC., GREENVILLE, SC:
2,911,468, CANC. INT. CL. 16.

BOBST SA, SWITZERLAND:
4,014,511, PUB. 6-7-2011. INT. CL. 7.
4,014,535, PUB. 6-7-2011. INT. CL. 7.

BODINE, PAUL ARTHUR, CHICAGO, IL:
4,017,416, INT. CL. 41.

BODY WISE INTERNATIONAL, LLC, IRVINE, CA:
2,463,860, REN. 7-16-11. INT. CL. 5.

BODYLASTICS INTERNATIONAL, INC., BOCA RATON, FL TO BODYLASTICS INTERNATIONAL, INC., BOCA RATON, FL:
2,412,853, CANC. INT. CL. 28.

BODYMEDIA, INC., PITTSBURGH, PA:
2,910,979, CANC. INT. CL. 9.

BOEHRINGER INGELHEIM INTERNATIONAL GMBH, FED REP GERMANY:
4,014,651, PUB. 6-7-2011. INT. CL. 5.
4,014,652, PUB. 6-7-2011. INT. CL. 5.
4,014,653, PUB. 6-7-2011. INT. CL. 5.
4,014,654, PUB. 6-7-2011. INT. CL. 5.
4,014,655, PUB. 6-7-2011. INT. CL. 5.
4,014,656, PUB. 6-7-2011. INT. CL. 5.
4,014,657, PUB. 6-7-2011. INT. CL. 5.
4,014,658, PUB. 6-7-2011. INT. CL. 5.
4,014,659, PUB. 6-7-2011. INT. CL. 5.
4,014,660, PUB. 6-7-2011. INT. CL. 5.
4,014,661, PUB. 6-7-2011. INT. CL. 5.
4,014,662, PUB. 6-7-2011. INT. CL. 5.
4,014,663, PUB. 6-7-2011. INT. CL. 5.
4,014,665, PUB. 6-7-2011. INT. CL. 5.
4,014,669, PUB. 6-7-2011. INT. CL. 5.

BOEHRINGER INGELHEIM INTERNATIONAL GMBH, INGELHEIM, FED REP GERMANY:
4,015,466, PUB. 6-7-2011. MULTIPLE CLASS, INT. CLS. 41 AND 42.

BOEHRINGER INGELHEIM PHARMA GMBH & CO. KG, INGELHEIM AM RHEIN, FED REP GERMANY:
2,910,775, CANC. INT. CL. 5.
2,910,776, CANC. INT. CL. 5.

BOEHRINGER INGELHIM PHARMA GMBH & CO. KG, INGELHEIM AM RHEIN, FED REP GERMANY:
2,910,740, CANC. INT. CL. 5.

BOKWA FITNESS, SAN GABRIEL, CA:
4,017,117, INT. CL. 41.

BOLEJACK, JULIE K., SHELBYVILLE, IN:
4,015,356, PUB. 6-7-2011. INT. CL. 30.

BOLLENBACH, PAUL E III, PALM COAST, FL:
2,911,140, CANC. INT. CL. 41.

BONAFARM ZRT., HUNGARY:
4,014,492, PUB. 6-7-2011. MULTIPLE CLASS, INT. CLS. 29, 30, 31, 32, 33, 35, 36, 40 AND 43.

BOND BUILDING SYSTEMS, INC., HOLLYWOOD, FL:
2,911,517, CANC. INT. CL. 6.

BOND JEWELERS, INC., PHILADELPHIA, PA:
4,017,390, INT. CL. 35.

BONE DADDY'S, INC., ADDISON, TX:
2,471,883, REN. 7-16-11. INT. CL. 42.

BONNE SANTE LLC, OLD LYME, CT:
4,016,540, INT. CL. 3.

BOOKIT.COM, INC., PANAMA CITY BEACH, FL:
4,015,599, PUB. 6-7-2011. MULTIPLE CLASS, INT. CLS. 35 AND 39.

BOOMERANGIT, INC., EMERYVILLE, CA:
2,461,134, REN. 7-20-11. INT. CL. 42.

BOOT ROYALTY COMPANY, L.P., FORT WORTH, TX:
4,015,811, PUB. 6-7-2011. INT. CL. 25.

BOOTS TO SHOES FOUNDATION, KIRKLAND, WA:
4,015,413, PUB. 6-7-2011. INT. CL. 35.
4,015,414, PUB. 6-7-2011. INT. CL. 35.
4,015,423, PUB. 6-7-2011. INT. CL. 35.

BOPPY COMPANY, LLC, THE, GOLDEN:
2,584,321, REN. 7-16-11. INT. CL. 20.

BORMIOLI ROCCO & FIGLIO S.P.A., 43036 FIDENZA, PARMA, ITALY, VETRERIA PARMENSE BORMIOLI ROCCO S.P.A., 43100 PARMA, ITALY:
1,650,626, REN. 7-19-11. MULTIPLE CLASS, INT. CLS. 9

- AND 21.
- BORRELLI, ALBERT & KIM VO, WEST HOLLYWOOD, CA:
2,909,476, CANC. MULTIPLE CLASS, INT. CLS. 3 AND 44.
- BOS KAASGEREEDSCHAPPEN B.V., NETHERLANDS:
4,014,598, PUB. 6-7-2011. MULTIPLE CLASS, INT. CLS. 11, 21 AND 25.
- BOSE CORPORATION, FRAMINGHAM, MA:
2,412,627, CANC. INT. CL. 41.
- BOSTON PAINCARE CENTER, INC., WALTHAM, MA:
4,017,125, INT. CL. 44.
- BOSTONBEAN COFFEE COMPANY, INC., WOBURN, MA:
2,573,271, REN. 7-19-11. INT. CL. 30.
- BOTTLERS INT. LTD, CLEARBROOK, VA:
400,434, CANC. U.S. CL. 45.
- BOUGHT INCORPORATED, BRYN ATHYN, PA:
4,016,795, INT. CL. 9.
4,016,796, INT. CL. 9.
- BOULEVARDS NEW MEDIA, INC., SAN JOSE, CA:
3,552,547, COR. INT. CL. 35.
- BOWEN, MEGHAN M, PORTLAND, OR:
4,015,396, PUB. 6-7-2011. INT. CL. 41.
- BOWLE, MICHAEL, LOUIS, GRESHAM, OR:
2,911,770, CANC. MULTIPLE CLASS, INT. CLS. 9 AND 41.
- BOWLINGBALL.COM, INC., DAYTONA BEACH, FL:
4,015,343, PUB. 6-7-2011. INT. CL. 35.
- BOWMAN, TERRY, MADISON, NC AND BOWMAN, ELVINA, MADISON, NC:
4,016,888, INT. CL. 18.
- BOYLE'S FAMOUS CORNED BEEF COMPANY, KANSAS CITY, MO:
914,134, REN. 7-16-11. U.S. CL. 46 (INT. CLS. 1, 5, 29, 30, 31 AND 32).
- BOYS & GIRLS CLUBS OF AMERICA, ATLANTA, GA:
720,143, REN. 7-18-11. U.S. CL. 200.
- BOYS & GIRLS CLUBS OF AMERICA, ATLANATA, GA:
2,823,247, CANC. INT. CL. 41.
- BRACKEN GARSON CONSULTING GROUP, LLC, WASHINGTON, DC:
4,015,714, PUB. 6-7-2011. INT. CL. 35.
- BRADKEN RESOURCES PTY LIMITED, MAYFIELD WEST, AUSTRALIA:
4,014,520, PUB. 6-7-2011. INT. CL. 7.
- BRADLEY AIRPORT VALET PARKING INC., SUFFIELD, CT, DBA EXECUTIVE VALET PARKING:
4,015,493, PUB. 6-7-2011. INT. CL. 39.
- BRADLEY, GRADY A, GOLDENDALE, WA:
4,015,500, PUB. 6-7-2011. INT. CL. 9.
- BRAIN POWER INCORPORATED, MIAMI, FL:
2,531,803, REN. 7-21-11. INT. CL. 1.
- BRAINSTORM STUDIOS, LLC, NORTHGLENN, CO:
2,910,766, CANC. INT. CL. 42.
- BRAKE PARTS, INC., MCHENRY, IL:
4,017,135, INT. CL. 12.
- BRAKE SUPPLY COMPANY, INC., EVANSVILLE, IN:
2,411,697, CANC. INT. CL. 42.
- BRAMMALL, INC., ANGOLA, IN:
3,306,241, COR. MULTIPLE CLASS, INT. CLS. 6 AND 20.
3,368,206, COR. MULTIPLE CLASS, INT. CLS. 6 AND 20.
3,558,128, COR. MULTIPLE CLASS, INT. CLS. 6 AND 20.
- BRASS CRAFT MANUFACTURING COMPANY, NOVI, MI:
2,541,872, REN. 7-19-11. INT. CL. 11.
- BRAZENN ENTERPRISES INC, EASTON, PA:
4,017,214, MULTIPLE CLASS, INT. CLS. 6 AND 20.
- BREATH OF HOPE FOUNDATION, INC., HOUSTON, TN:
4,016,616, INT. CL. 41.
- BREG INTERNATIONAL, FREDRICKSBURG, VA:
2,910,501, CANC. INT. CL. 40.
- BRENNING, DIETER, ROSENGARTEN, FED REP GERMANY:
2,472,508, REN. 7-15-11. INT. CL. 20.
- BRENSINGER, CAM, ALAN, NASHUA, NH:
2,911,596, CANC. INT. CL. 22.
- BRESNAN COMMUNICATIONS LLC, PURCHASE, NY:
2,911,497, CANC. INT. CL. 38.
- BRETTON CAPITAL MANAGEMENT LLC, SAN FRANCISCO, CA:
4,016,843, INT. CL. 36.
- BREW CORP., PORTLAND, ME, DBA GRITTY MCDUFF'S:
4,015,436, PUB. 6-7-2011. INT. CL. 43.
- BRIANA T BENNITT, BELLEVUE, WA, DBA SIMPLICITY LEARNING CENTER:
4,015,490, PUB. 6-7-2011. INT. CL. 41.
- BRICKELL FINANCIAL SERVICES-MOTOR CLUB, INC., MIAMI, FL:
4,015,213, PUB. 6-7-2011. MULTIPLE CLASS, INT. CLS. 35, 36, 37, 39 AND 45.
- BRICKSTOP CORPORATION, TORONTO, ONTARIO, CANADA:
4,014,850, PUB. 6-7-2011. INT. CL. 20.
- BRIDGESITE CLINICAL RESEARCH, INC., COLUMBUS, OH:
2,911,000, CANC. INT. CL. 42.
- BRIDGMAN, WILLIAM, NORTHFIELD, IL:
4,017,095, INT. CL. 35.
- BRIDOR INC., BOUCHERVILLE, QUEBEC, CANADA:
2,523,854, REN. 7-18-11. INT. CL. 35.
- BRIGADE SALES & MARKETING, INC., DALLAS, TX:
2,910,087, CANC. INT. CL. 18.
- BRIGGS & STRATTON CORPORATION, MILWAUKEE, WI:
2,911,708, CANC. MULTIPLE CLASS, INT. CLS. 7 AND 12.
- BRIGHAM YOUNG UNIVERSITY, PROVO, UT:
2,910,644, CANC. INT. CL. 25.
3,460,308, AM. MULTIPLE CLASS, INT. CLS. 25 AND 41.
- BRILL, WILLIAM, LITTLETON, CO:
4,017,006, INT. CL. 41.
- BRINC INTERACTIVE, BURBANK, CA:
2,910,900, CANC. INT. CL. 42.
- BRITANNE CORPORATION, SAN FRANCISCO, CA:
1,650,800, REN. 7-18-11. INT. CL. 24.
- BRITISH AIRWAYS PLC, WEST DRAYTON, UNITED KINGDOM:
1,624,080, REN. 7-20-11. INT. CL. 39.
- BROCK, NATHANIEL, VICTORVILLE, CA:
4,015,447, PUB. 6-7-2011. INT. CL. 25.
- BRODA ENTERPRISES INC., KITCHENER, ONTARIO, CANADA:
4,014,782, PUB. 6-7-2011. INT. CL. 12.
- BRONSON NUTRITIONALS, LLC, HAUPPAUGE, NY:
4,015,452, PUB. 6-7-2011. MULTIPLE CLASS, INT. CLS. 3, 5 AND 35.
- BROOD-EN BANKETBAKKERIJEN LA LORRAINE OR, IN FRENCH: BOULANGERIE-PATISSERIE LA LORRAINE, 9400 NINOVE, BELGIUM:
2,412,016, CANC. INT. CL. 30.
- BROOKS AUTOMATION, INC., CHELMSFORD, MA:
2,578,620, REN. 7-15-11. INT. CL. 9.
- BROWN & BROWN OF MISSOURI, INC., ST. LOUIS, MO:
4,015,660, PUB. 6-7-2011. INT. CL. 36.
- BROWN & WILLIAMSON TOBACCO CORPORATION, LOUISVILLE, KY:
2,910,509, CANC. INT. CL. 9.
- BROWN GROUP, INC., ST. LOUIS, MO, ARNOLD DUNN INCORPORATED, NEW YORK, NY:
1,160,119, REN. 7-16-11. INT. CL. 25.
- BROWN MEDICAL INDUSTRIES, INC., SPIRIT LAKE, IA:
4,015,735, PUB. 6-7-2011. INT. CL. 10.
- BROWN, SAMANTHA, NEW YORK, NY:
4,016,705, MULTIPLE CLASS, INT. CLS. 18 AND 39.
- BROWNE, JILL CONNER, JACKSON, MS:
2,460,777, REN. 7-16-11. INT. CL. 41.
- BRUNELLO CUCINELLI S.P.A., ITALY:
4,014,464, PUB. 6-7-2011. MULTIPLE CLASS, INT. CLS. 3, 9, 18, 24 AND 35.
- BRUNI, SIMONE, NEW ORLEANS, LA:
4,016,706, MULTIPLE CLASS, INT. CLS. 25 AND 37.
- BRUNO BANANI UNDERWEAR GMBH, CHEMNITZ, FED REP GERMANY:
2,905,413, CANC. MULTIPLE CLASS, INT. CLS. 16, 20 AND 28.

BRUNO SATTLECKER, 83395 FREILASSING, FED REP GERMANY:
4,014,554, PUB. 6-7-2011. INT. CL. 9.

BRUNSWICK BOWLING & BILLIARDS CORPORATION, LAKE FOREST, IL:
2,910,062, CANC. INT. CL. 35.

BRUNSWICK COMMERCIAL & GOVERNMENT PRODUCTS, INC., EDGEWATER, FL:
2,799,767, CANC. INT. CL. 12.

BRUNSWICK CORPORATION, LAKE FOREST, IL:
2,585,211. REN. 7-15-11. INT. CL. 7.
2,585,212. REN. 7-15-11. INT. CL. 7.
2,585,664. REN. 7-15-11. INT. CL. 12.

BRUS HOLDING EUROPE B.V., NETHERLANDS:
4,014,619, PUB. 6-7-2011. INT. CL. 29.

BRUSH FOOTWEAR, LLC, NATRONA HEIGHTS, PA:
4,016,871, INT. CL. 25.
4,017,025, INT. CL. 25.

BRYANT, ROY K., SAN DIEGO, CA AND ALFREDO N. VEJAR, SAN DIEGO, CA:
4,016,210, INT. CL. 39.

BSN MEDICAL GMBH, HAMBURG, FED REP GERMANY:
4,017,202, INT. CL. 10.

BUCKET CLOTHING LLC, MILILANI, HI:
2,910,976, CANC. INT. CL. 25.

BUCKEYE RESOURCES, INC., SOUTH CHARLESTOWN, OH:
2,910,164, CANC. INT. CL. 31.

BUCKSKIN ARMOR LLC, POCASSET, OK:
4,015,690, PUB. 6-7-2011. INT. CL. 25.

BUDDY'S KITCHEN, INC., BURNSVILLE, MN:
2,911,367, CANC. INT. CL. 29.

BUEHNER-FRY, INCORPORATED, BEND, OR, DBA NAVIS:
2,590,577. REN. 7-20-11. INT. CL. 38.

BUENA VISTA UNIVERSITY, STORM LAKE, IA:
4,015,986, PUB. 6-7-2011. INT. CL. 41.
4,015,989, PUB. 6-7-2011. INT. CL. 41.

BUILD-A-BEAR RETAIL MANAGEMENT, INC., ST. LOUIS, MO:
2,911,116, CANC. INT. CL. 28.
2,911,121, CANC. INT. CL. 35.

BUILDERADIUS, INC., ASHEVILLE, NC:
4,015,604, PUB. 6-7-2011. INT. CL. 35.

BUILDMYPRODUCT.COM LLC, HAMPTON, VA:
4,016,301, INT. CL. 42.

BULKREGISTER, LLC, BALTIMORE, MD:
2,910,093, CANC. INT. CL. 42.

BULLDOG PRODUCTS, INC., ANAHEIM HILLS, CA:
2,910,968, CANC. INT. CL. 16.

BUNDY AMERICAN, LLC, LAUREL, MD:
2,509,881. REN. 7-18-11. INT. CL. 39.

BUNGE MILLING, INC., ST. LOUIS, MO:
281,822. REN. 7-15-11. U.S. CL. 46 (INT. CL. 30).

BUNNIES BY THE BAY, INC., ANACORTES, WA:
2,910,595, CANC. MULTIPLE CLASS, INT. CLS. 16, 21, 25 AND 28.
2,910,597, CANC. MULTIPLE CLASS, INT. CLS. 20 AND 21.

BUNTON, SR., DALLAS S., CHATTANOOGA, TN:
4,016,143, PUB. 6-7-2011. MULTIPLE CLASS, INT. CLS. 16 AND 41.

BURD, DARRELL E., DUNEDIN, FL AND BURD, KAREN S., DUNEDIN, FL:
2,411,777, CANC. INT. CL. 42.

BURMER, GLENNA C., SEATTLE, WA:
4,016,773, INT. CL. 9.

BURROUGHS & CHAPIN COMPANY, INC., MYRTLE BEACH, SC, OCEAN FOREST, INC., MYRTLE BEACH, SC, DBA PINE LAKES INTERNATIONAL COUNTRY CLUB:
914,774. REN. 7-19-11. U.S. CL. 107 (INT. CL. 41).

BUSH, SCOTT A., MASSILLON, OH:
2,909,939, CANC. INT. CL. 28.

BUSINESS BY DESIGN, LLC, TEMPE, AZ:
2,875,622, CANC. INT. CL. 41.

BUSINESS WARRIOR INSTITUTE, LLC, BEVERLY HILLS, CA:
4,015,206, PUB. 6-7-2011. MULTIPLE CLASS, INT. CLS. 16 AND 41.

BUSINESSSTONE LLC, NEW YORK, NY:
2,467,286. REN. 7-15-11. INT. CL. 28.

BUSS GENERAL PARTNER CO. LTD., DELTA, CANADA, DBA BASEBOARDERS:
4,017,207, INT. CL. 6.

BUTCH BAKERY LLC, NEW YORK CITY, NY:
4,014,935, PUB. 6-7-2011. INT. CL. 35.

BUZZBANDZ, LLC, STAFFORD, TX:
4,016,845, INT. CL. 14.

BVW HOLDINGS, LLC, OCEANSIDE, CA:
4,015,151, PUB. 6-7-2011. INT. CL. 9.

C AND A COURTENAY MINISTRIES, BROOKLYN, NY:
4,016,554, MULTIPLE CLASS, INT. CLS. 16, 18, 24, 25, 36, 41 AND 45.

C AND C DESIGN TECHNOLOGY, LLC, PALM BEACH GARDENS, NY:
4,016,245, INT. CL. 9.

C D LISTENING BAR, INC., IRVINE, CA, DBA SUPER D:
4,016,959, INT. CL. 9.

C K PROCESSING CO., MUSCATINE, IA:
1,155,014. REN. 7-20-11. INT. CL. 31.

C. G. EDWARDS & CO., INC., S. BOSTON, MA:
2,412,253, CANC. INT. CL. 6.

C. KIRIN CHRISTIANSON, SCOTTSDALE, AZ:
4,016,895, INT. CL. 42.

C. L. BARNHOUSE COMPANY, OSKALOOSA, IA:
2,411,898, CANC. INT. CL. 35.
2,411,902, CANC. MULTIPLE CLASS, INT. CLS. 9 AND 35.
2,411,903, CANC. MULTIPLE CLASS, INT. CLS. 9 AND 42.

C. R. BARD, INC., MURRAY HILL, NJ:
4,015,866, PUB. 6-7-2011. INT. CL. 10.

C.A.S. IBERIA, INC., SALE CREEK, TN:
2,910,050, CANC. INT. CL. 35.
2,910,051, CANC. INT. CL. 35.

C.I. UNION DE BANAEROS DE URABA, S.A., NUMBER 47-42 MEDELLIN, COLOMBIA, DBA UNIBAN:
2,909,420, CANC. INT. CL. 35.
2,909,421, CANC. INT. CL. 38.

C.L. HENDERSON PRODUCE, LLC, HENDERSONVILLE, NC:
1,178,379. REN. 7-18-11. MULTIPLE CLASS, INT. CLS. 31 AND 32.

C.P. INTERNATIONAL CORPORATION, ENGLEWOOD, NJ:
2,460,533. REN. 7-18-11. INT. CL. 25.

C/HCA, INC., NASHVILLE, TN:
2,474,334. REN. 7-20-11. INT. CL. 42.
2,474,335. REN. 7-20-11. INT. CL. 35.

CAADES SINALOA, A.C., COYOACAN, SINALOA, MEXICO:
4,014,423, PUB. 6-7-2011. MULTIPLE CLASS, INT. CLS. 29, 31 AND 35.

CABO WABO LLC, SAN FRANCISCO, CA:
2,911,300, CANC. INT. CL. 25.

CABRERA, RAFAEL, BOCA RATON, FL, DBA PLASTIC SURGERY SPECIALISTS OF BOCA RATON:
4,014,878, PUB. 6-7-2011. INT. CL. 44.

CACHET BANQ, PASADENA, CA:
4,016,906, INT. CL. 36.

CACTUS, LLC, CHARLESTON, SC:
4,016,663, INT. CL. 10.

CADORE MODA, INC., CORAL GABLES, FL:
2,910,047, CANC. INT. CL. 9.

CAESARS LICENSE COMPANY, LLC, LAS VEGAS, NV:
2,985,522, CANC. INT. CL. 41.

CAFE NEGRO GALLERIA, S. DE R.L. DE C.V., ZAPOPAN, JALISCO, MEXICO:
4,014,410, PUB. 6-7-2011. MULTIPLE CLASS, INT. CLS. 35 AND 41.

CAFE SEVILLA, INC., SAN DIEGO, CA:
2,909,915, CANC. INT. CL. 33.

- CAFÉ DE EXPORTACIÓN SAN JUANILLO SOCIEDAD ANÓNIMA, SAN JOSE, COSTA RICA:
2,910,671, CANC. INT. CL. 30.
- CAIDAN MANAGEMENT COMPANY, LLC, DETROIT, MI:
4,017,318, INT. CL. 36.
- CALDERON TEXTILES, LLC, INDIANAPOLIS, IN:
2,910,452, CANC. INT. CL. 24.
- CALDWELL CONSUMER HEALTH, LLC, MADISON, NJ, DBA REVIVE PERSONAL PRODUCTS COMPANY:
1,609,550, REN. 7-21-11. INT. CL. 5.
- CALDWELL, DALE G., NEW BRUNSWICK, NJ:
4,015,967, PUB. 6-7-2011. INT. CL. 35.
- CALEB FOSTER WINES, L.L.C., WALLA WALLA, WA:
4,016,238, INT. CL. 33.
- CALEEL + HAYDEN, L.L.C., DENVER, CO:
4,014,199, PUB. 3-1-2011. MULTIPLE CLASS, INT. CLS. 3 AND 18.
4,014,200, PUB. 3-1-2011. MULTIPLE CLASS, INT. CLS. 3, 18, 35 AND 44.
- CALHOUN, CYNTHIA, MELBOURNE, FL:
4,015,004, PUB. 6-7-2011. MULTIPLE CLASS, INT. CLS. 9 AND 16.
- CALIBERS NATIONAL SHOOTERS SPORTS CENTERS, LC, ALBUQUERQUE, NM:
4,015,997, PUB. 6-7-2011. INT. CL. 41.
4,015,999, PUB. 6-7-2011. INT. CL. 41.
- CALIFORNIA BAPTIST UNIVERSITY, RIVERSIDE, CA:
4,015,832, PUB. 6-7-2011. INT. CL. 41.
- CALIFORNIA EXOTIC NOVELTIES LLC, CHINO, CA:
4,015,721, PUB. 6-7-2011. INT. CL. 9.
- CALIFORNIA PRODUCTS CORPORATION, ANDOVER, MA:
4,016,860, INT. CL. 2.
- CALIFORNIA SKIN LASER CENTER, STOCKTON, CA:
2,910,708, CANC. INT. CL. 3.
- CALISTA COSMETICS, UWCHLAN, PA:
4,015,846, PUB. 6-7-2011. INT. CL. 3.
- CALMER CORN HEADS, INC., ALPHA, IL, AKA CALMER CORN HEADS:
4,016,960, INT. CL. 7.
- CALVANDER COMMUNICATIONS, INC., CHAPEL HILL, NC:
4,015,483, PUB. 6-7-2011. INT. CL. 9.
- CALVO ENTERTAINMENT CORP., BROOKLYN, NY, DBA CALVO ENTERTAINMENT CORP.:
4,014,396, PUB. 6-7-2011. MULTIPLE CLASS, INT. CLS. 35 AND 45.
- CALZATURIFICIO FRATELLI SOLDINI S.P.A., 1-52010 CAPOLONA - AREZZO, ITALY:
2,910,187, CANC. INT. CL. 25.
- CAMPBELL TOBACCO REHANDLING COMPANY, MAYFIELD, KY:
1,647,606, REN. 7-16-11. INT. CL. 34.
- CAMPBELL, DOREEN M., TRABUCO CANYON, CA:
2,911,035, CANC. INT. CL. 16.
- CAMPISI, RICHARD M, SANTA ROSA BEACH, FL, DBA SALTY DUDE:
4,015,315, PUB. 6-7-2011. INT. CL. 25.
- CAMPUS CRUSADE FOR CHRIST, INC., ORLANDO, FL, AKA CAMPUS CRUSADE FOR CHRIST INTERNATIONAL; CCCI:
4,014,788, PUB. 6-7-2011. MULTIPLE CLASS, INT. CLS. 9, 16, 35, 38, 41 AND 45.
- CANADELLE LIMITED PARTNERSHIP, MONTREAL, QUEBEC, CANADA:
2,911,150, CANC. INT. CL. 25.
- CANADIAN STANDARDS ASSOCIATION, ETOBICOKE (TORONTO), ONTARIO M9W 1R3, CANADA:
2,498,742, REN. 7-16-11. U.S. CL. A.
- CANDIA, PARIS, FRANCE, SOCIETE DE DEVELOPPEMENTS ET D'INNOVATIONS DES MARCHES AGRICOLES ET ALIMENTAIRES - SODIMA UNION DE COOPERATIVES AGRICOLES, 75014 PARIS, FRANCE:
1,647,537, REN. 7-16-11. INT. CL. 29.
- CANDLE ARTISANS, INC., WASHINGTON, NJ:
2,470,067, REN. 7-18-11. INT. CL. 4.
- CANINE COZY CARE RESORT LLC, STANWOOD, WA:
4,015,039, PUB. 6-7-2011. INT. CL. 43.
- CANOPY MANAGEMENT, LLC, NAPA, CA:
4,016,115, PUB. 6-7-2011. INT. CL. 36.
- CANTINA GROUP, INC., BIRMINGHAM, AL:
4,015,148, PUB. 6-7-2011. INT. CL. 43.
- CANTOR FITZGERALD SECURITIES, NEW YORK, NY:
4,015,683, PUB. 6-7-2011. MULTIPLE CLASS, INT. CLS. 9, 38, 41 AND 42.
- CAO GROUP, INC., WEST JORDAN, UT:
4,016,097, PUB. 6-7-2011. INT. CL. 11.
4,016,099, PUB. 6-7-2011. INT. CL. 3.
4,016,100, PUB. 6-7-2011. INT. CL. 5.
4,016,101, PUB. 6-7-2011. INT. CL. 5.
- CAPE CLASSICS BRANDS LLC, WEST PALM BEACH, FL:
4,017,236, INT. CL. 33.
- CAPE CLEAR SOFTWARE LIMITED, DUBLIN 2, IRELAND:
2,911,374, CANC. INT. CL. 9.
- CAPELLA TECHNOLOGIES, INC., ANAHEIM, CA:
4,016,079, PUB. 6-7-2011. INT. CL. 9.
- CAPITAL ONE FINANCIAL CORPORATION, RICHMOND, VA:
4,017,101, MULTIPLE CLASS, INT. CLS. 35 AND 36.
- CAPLANSON, WINTER BROOKE, COVENTRY, CT:
2,911,276, CANC. INT. CL. 3.
- CAPO, RALPH J., EL SEGUNDO, CA:
2,909,919, CANC. INT. CL. 19.
- CAPOGIRO LICENSING LIMITED LIABILITY COMPANY C/O LDA KFT, H-1143 BUDAPEST, HUNGARY:
4,014,483, PUB. 6-7-2011. MULTIPLE CLASS, INT. CLS. 16, 25 AND 41.
- CAPTAIN D'S HOLDINGS, INC., NASHVILLE, TN:
2,911,209, CANC. INT. CL. 29.
2,911,210, CANC. INT. CL. 29.
- CAPTIO CORPORATION, SAN FRANCISCO, CA:
2,911,058, CANC. INT. CL. 16.
- CAPTURE BUSINESS CARDS, LLC, EDINA, MN:
2,412,668, CANC. INT. CL. 16.
- CAR WASH USA, LTD, LEWIS, OH:
2,490,565, REN. 7-16-11. INT. CL. 37.
- CARAVAN RETREATS INCORPORATED, SAN FRANCISCO, CA:
4,015,140, PUB. 6-7-2011. INT. CL. 41.
- CARDELL, ELIZA, FOREST HILL VICTORIA, AUSTRALIA:
2,910,419, CANC. INT. CL. 41.
- CARDIACMD, INC., MENLO PARK, CA:
2,911,046, CANC. INT. CL. 42.
- CARDINAL CG COMPANY, EDEN PRAIRIE, MN:
4,017,128, MULTIPLE CLASS, INT. CLS. 2 AND 17.
- CARDINAL HEALTH TECHNOLOGIES, LLC, LAS VEGAS, NV:
2,953,042, COR. MULTIPLE CLASS, INT. CLS. 35 AND 42.
2,953,043, COR. INT. CL. 25.
2,953,177, COR. MULTIPLE CLASS, INT. CLS. 39, 42 AND 44.
- CARDIOCOM, LLC, EXCELSIOR, MN:
2,654,278, COR. INT. CL. 44.
- CARE SOLUTIONS, LLC, FORT LEE, NJ:
4,015,069, PUB. 6-7-2011. INT. CL. 44.
- CAREER PARTNERS INTERNATIONAL LLC, CHAPEL HILL, NC:
4,014,972, PUB. 6-7-2011. INT. CL. 35.
- CAREERARC GROUP LLC, BURBANK, CA:
4,016,428, MULTIPLE CLASS, INT. CLS. 35, 38, 41 AND 42.
4,016,429, MULTIPLE CLASS, INT. CLS. 35, 38, 41 AND 42.
- CAREFREE SKINCARE, PARKER, CO:
4,015,126, PUB. 6-7-2011. INT. CL. 3.
- CAREY A. GRUND, LAKE ORION, MI:
4,014,991, PUB. 6-7-2011. INT. CL. 16.
- CARGILL, INCORPORATED, WAYZATA, MN:
2,911,180, CANC. INT. CL. 31.
- CARHARTT, INC., DEARBORN, MI:
4,017,139, INT. CL. 25.
- CARIBBEAN ELECTRONIC ENTERPRISES, INC., MIAMI, FL, AKA SOUND BARRIER CORP. OF FLORIDA:
1,648,023, REN. 7-15-11. INT. CL. 9.

CARING HANDS FOR SENIORS, BRISTOW, VA:
4,017,158, INT. CL. 44.

CARLISLE INTANGIBLE COMPANY, SYRACUSE, NY,
NICOLON CORPORATION, PENDERGRASS, GA:
1,697,269, REN. 7-16-11. INT. CL. 1.

CARLISLE INTANGIBLE COMPANY, SYRACUSE, NY:
4,016,967, INT. CL. 7.

CARMICHAEL, CHARLENE W., PLYMOUTH, MA:
2,911,243, CANC. INT. CL. 42.

CAROLINA BIOLOGICAL SUPPLY COMPANY, BURLING-
TON, NC:
4,014,804, PUB. 6-7-2011. MULTIPLE CLASS, INT. CLS. 16
AND 41.

CAROLINA EAR & HEARING CLINIC, PC, RALEIGH, NC:
4,016,995, INT. CL. 42.

CAROLINA MATTRESS GUILD, INC., THOMASVILLE, NC:
2,910,694, CANC. INT. CL. 20.

CAROLINA WEST WIRELESS, INC., WILKESBORO, NC:
4,015,475, PUB. 6-7-2011. MULTIPLE CLASS, INT. CLS. 35
AND 38.

CARON, DIANNE L. EVERSON, WA:
4,014,994, PUB. 6-7-2011. MULTIPLE CLASS, INT. CLS. 9
AND 41.

CARPENTER, ELIZABETH S, NEW YORK, NY:
4,016,296, INT. CL. 28.

CARR, DAVID, NASHVILLE, TN:
2,459,597, REN. 7-16-11. INT. CL. 37.

CARRIER CORPORATION, FARMINGTON, CT:
4,016,119, PUB. 6-7-2011. INT. CL. 11.
4,017,037, INT. CL. 35.

CARROLL, BIME L, JACKSON, MS:
4,016,998, MULTIPLE CLASS, INT. CLS. 25 AND 35.
4,016,999, INT. CL. 25.

CARROLL, CRYSTAL, PASCO, WA:
4,015,780, PUB. 6-7-2011. INT. CL. 43.
4,015,784, PUB. 6-7-2011. INT. CL. 43.
4,015,789, PUB. 6-7-2011. INT. CL. 43.

CARSON-DELLOSA PUBLISHING, LLC, GREENSBORO,
NC:
2,465,617, REN. 7-19-11. INT. CL. 16.

CARSON-DELLOSA PUBLISHING, LLC, GREENSBORO,
NC:
2,469,658, REN. 7-19-11. INT. CL. 16.

CARTER, MARY BETH, VISALIA, CA:
4,016,328, INT. CL. 35.

CARTER, NETWAUN, WOODBRIDGE, VA:
4,017,069, INT. CL. 41.

CARTIER INTERNATIONAL A.G., 6312 STEINHAUSEN,
SWITZERLAND:
2,909,669, CANC. INT. CL. 3.

CARTIER INTERNATIONAL AG, SWITZERLAND:
4,014,471, PUB. 6-7-2011. INT. CL. 18.

CARTILS GROUP B.V., NETHERLANDS:
4,014,459, PUB. 6-7-2011. MULTIPLE CLASS, INT. CLS.
35, 41 AND 42.

CARUSO, JAMES S., WINNETKA, IL:
2,910,957, CANC. INT. CL. 25.

CARVED RECORDS, LLC, LUBBOCK, TX:
4,014,712, PUB. 6-7-2011. INT. CL. 9.

CASCADES TISSUE GROUP-IFC DISPOSABLES INC.,
BROWNSVILLE, TN:
1,680,423, REN. 7-19-11. INT. CL. 21.

CASE-ARI, LLC, TUCKER, GA, DBA CASE-MATE:
4,015,631, PUB. 6-7-2011. INT. CL. 9.

CASEMARK, INC., WILMINGTON, DE:
2,450,195, REN. 7-16-11. INT. CL. 8.

CASEMOE INCORPORATED, LEE'S SUMMIT, MO:
4,015,672, PUB. 6-7-2011. INT. CL. 3.

CASEWARE INTERNATIONAL INC., TORONTO, ONTAR-
IO M5V 1K4, CANADA:
2,423,582, REN. 7-16-11. INT. CL. 9.

CASH, TY A, TAVERNIER, FL:
2,910,568, CANC. INT. CL. 41.

CASIANO COMMUNICATIONS, INC., SAN JUAN, PUERTO
RICO:
2,469,781, REN. 7-15-11. INT. CL. 16.
2,910,481, CANC. INT. CL. 16.

CASINO DE PARIS, FRANCE:
4,014,534, PUB. 6-7-2011. INT. CL. 3.

CASPER'S HOT DOGS, LAFAYETTE, CA:
1,182,505, REN. 7-18-11. INT. CL. 42.

CATALYST SYSTEMS CORPORATION, CHICAGO, IL, DBA
OPENMAKE SOFTWARE:
4,017,315, INT. CL. 9.

CATFISH PARLOUR, INC., AUSTIN, TX:
1,158,526, REN. 7-19-11. INT. CL. 42.

CATHERINE G FARRAR, LOCH ARBOUR, NJ:
2,911,166, CANC. INT. CL. 35.

CATHETER CONNECTIONS, SALT LAKE CITY, UT:
4,016,320, INT. CL. 10.

CATHOLICS IN ACTION, YAKIMA, WA:
2,910,469, CANC. INT. CL. 45.

CATNIP TRAILS, INC., HAINES CITY, FL:
4,015,305, PUB. 6-7-2011. INT. CL. 16.

CATS IN THE CITY, LLC, SAN FRANCISCO, CA:
4,015,651, PUB. 6-7-2011. INT. CL. 43.

CAVALIER HOMES, INC., ADDISON, AL:
2,468,846, REN. 7-18-11. INT. CL. 35.

CAVE CREEK UNIFIED SCHOOL DISTRICT, SCOTTS-
DALE, AZ:
4,015,853, PUB. 6-7-2011. INT. CL. 41.

CAVIT CANTINA VITICOLTORI CONSORZIO CANTINE
SOCIALI DEL TRENTINO SOCIETA' COOPERATIVA,
ITALY:
4,014,592, PUB. 6-7-2011. INT. CL. 33.

CBOCS PROPERTIES, INC., LIVONIA, MI:
2,588,285, REN. 7-15-11. INT. CL. 29.

CBUS WIRELESS, LLC, COLUMBUS, OH:
4,017,364, INT. CL. 9.

CCM IP, S.A., CH-1005 LAUSANNE, SWITZERLAND, CER-
VECERIA CUAUHEMOC, S.A. DE C.V., MONTEREY,
NEUVO LEON 64442, MEXICO:
1,696,173, REN. 7-15-11. INT. CL. 25.

CDD HOLDING, LLC, MARINA DEL REY, CA:
4,014,793, PUB. 6-7-2011. INT. CL. 9.
4,014,807, PUB. 6-7-2011. INT. CL. 16.
4,014,808, PUB. 6-7-2011. INT. CL. 25.

CDF HOLDINGS LLC, SCOTTSDALE, AZ:
4,017,411, INT. CL. 35.
4,017,412, INT. CL. 35.
4,017,413, INT. CL. 35.
4,017,414, INT. CL. 35.

CDS FREIGHT HOLDING LTD., KWAI CHUNG, N.T.,
HONG KONG:
3,969,001, AM. INT. CL. 35.
3,972,862, AM. INT. CL. 35.

CE INNOVATIONS, INC., KALAMAZOO, MI:
2,911,286, CANC. INT. CL. 35.

CEANIX HEALTH INC., COLLINGWOOD, CANADA:
4,017,165, INT. CL. 10.

CEDAR FAIR, L.P., SANDUSKY, OH:
2,503,982, REN. 7-19-11. INT. CL. 41.

CEDAR GROVE COMPOSTING, INC., SEATTLE, WA:
4,015,794, PUB. 6-7-2011. MULTIPLE CLASS, INT. CLS.
16, 20 AND 21.

CEDARS-SINAI MEDICAL CENTER, LOS ANGELES, CA:
4,014,849, PUB. 6-7-2011. MULTIPLE CLASS, INT. CLS. 16
AND 35.
4,015,581, PUB. 6-7-2011. MULTIPLE CLASS, INT. CLS.
36, 41 AND 42.
4,015,582, PUB. 6-7-2011. MULTIPLE CLASS, INT. CLS.
36, 41 AND 42.

CELENTANO ADRIANO, MILANO, ITALY:
4,014,599, PUB. 6-7-2011. MULTIPLE CLASS, INT. CLS. 9,
14, 16, 25, 32 AND 41.

CELGARD, LLC, CHARLOTTE, SC, HOECHST CELANESE
CORPORATION, SOMERVILLE, NJ:
1,646,734, REN. 7-19-11. INT. CL. 9.

CELGENE CORPORATION, SUMMIT, NJ:
4,014,386, PUB. 6-7-2011. MULTIPLE CLASS, INT. CLS. 39
AND 44.
4,014,787, PUB. 6-7-2011. INT. CL. 5.

CELLULAR INTELLIGENCE, LLC, HIGHLAND PARK, IL:
4,015,250, PUB. 6-7-2011. INT. CL. 44.

- CELLULAR ONE LLC, LAS VEGAS, NV:
2,412,697, CANC. INT. CL. 27.
2,412,698, CANC. INT. CL. 11.
2,412,699, CANC. INT. CL. 6.
- CELONOVA BIOSCIENCES, INC., NEWNAN, GA:
2,910,378, CANC. MULTIPLE CLASS, INT. CLS. 1, 10, 40 AND 42.
- CELTIC LEASING CORP., IRVINE, CA:
2,473,668, REN. 7-19-11. INT. CL. 36.
- CENTA ANTRIEBE KIRSCHHEY GMBH, HAAN, FED REP GERMANY:
4,016,424, MULTIPLE CLASS, INT. CLS. 7 AND 12.
- CENTER FOR REAL ESTATE ENTERPRISE MANAGEMENT, SAN FRANCISCO, CA:
2,909,452, CANC. INT. CL. 36.
- CENTER FOR SACRED STUDIES, ON BEHALF OF INTERNATIONAL COUNCIL OF THIRTEEN INDIGENOUS GRANDMOTHERS, SONORA, CA:
4,014,694, PUB. 6-7-2011. MULTIPLE CLASS, INT. CLS. 35 AND 45.
- CENTRALIZED SUPPLY CHAIN SERVICES, LLC, LENEXA, KS:
4,014,949, PUB. 6-7-2011. INT. CL. 35.
- CENTRE D'ETUDES DE PHYSIOLOGIE D'HYGIENE ET DE COSMETOLOGIE (C.E.P.), F-93500 PANTIN, FRANCE:
4,014,610, PUB. 6-7-2011. INT. CL. 1.
- CENTRIX FINANCIAL, LLC, ENGLEWOOD, CO:
2,909,427, CANC. INT. CL. 36.
- CENTRUE BANK, KANKAKEE, IL:
2,910,124, CANC. INT. CL. 36.
- CENTRUE BANK, STREATOR, IL:
4,015,239, PUB. 6-7-2011. INT. CL. 36.
- CENTURY OAKS TITLE, LLC, LAKE JACKSON, TX:
4,015,225, PUB. 6-7-2011. INT. CL. 45.
- CENTURY OF PROGRESS PRODUCTIONS, SHERMAN OAKS, CA:
4,014,427, PUB. 6-7-2011. INT. CL. 41.
- CEQUENT PERFORMANCE PRODUCTS, INC., PLYMOUTH, MI:
2,486,994, REN. 7-20-11. INT. CL. 12.
- CERNA HEALTHCARE, LLC, IRVINE, CA:
4,017,395, MULTIPLE CLASS, INT. CLS. 35 AND 45.
- CERVECERIA MODELO, S.A. DE C.V., 11320 MEXICO, D.F., MEXICO:
2,910,046, CANC. INT. CL. 32.
- CEXI, LLC, CHANDLER, AZ:
2,911,153, CANC. MULTIPLE CLASS, INT. CLS. 3 AND 14.
- CFA INSTITUTE, CHARLOTTESVILLE, VA:
4,017,172, INT. CL. 9.
- CGI TECHNOLOGIES AND SOLUTIONS INC., FAIRFAX, VA:
2,412,178, CANC. INT. CL. 9.
2,412,179, CANC. INT. CL. 9.
- CHADI GHAITH, MOUNT LEBANON, LEBANON:
4,015,632, PUB. 6-7-2011. INT. CL. 45.
- CHAFFRINGEON BERNARD, SWITZERLAND:
4,014,633, PUB. 6-7-2011. INT. CL. 5.
- CHAMBER OF COMMERCE OF HUNTSVILLE/MADISON COUNTY, INC., HUNTSVILLE, AL:
4,015,044, PUB. 6-7-2011. INT. CL. 35.
- CHAMBERS-BELIDA, CANDACE, CORONA, CA:
4,016,822, INT. CL. 41.
- CHAMPION WINDOW MANUFACTURING AND SUPPLY CO., LLC, CINCINNATI, OH:
2,195,330, AM. MULTIPLE CLASS, INT. CLS. 19 AND 37.
- CHAN, CLAYTON A., LAS VEGAS, NV:
4,015,087, PUB. 6-7-2011. INT. CL. 41.
- CHANDLER CHICCO COMPANIES LLC, NEW YORK, NY:
4,016,511, MULTIPLE CLASS, INT. CLS. 35 AND 44.
- CHANGYOU.COM (US), INC, WILMINGTON, DE:
4,016,438, INT. CL. 41.
- CHANTRY NETWORKS INC., MISSISSAUGA, ONTARIO, CANADA:
2,910,541, CANC. INT. CL. 9.
- CHAO, WENDY, BOSTON, MA:
4,014,753, PUB. 6-7-2011. INT. CL. 25.
- CHARLES FRANK CANGEMI, JR., MOORESVILLE, NC:
4,015,455, PUB. 6-7-2011. INT. CL. 44.
- CHARLES J. SILLARI, JR., SOMERVILLE, MA:
4,015,336, PUB. 6-7-2011. INT. CL. 43.
- CHARLES SCHWAB & CO., INC., SAN FRANCISCO, CA:
2,910,959, CANC. MULTIPLE CLASS, INT. CLS. 9 AND 16.
- CHARLIE NEAL, JR., CARY, NC, DBA NEAL & COMPANY, INC.:
4,015,815, PUB. 6-7-2011. INT. CL. 19.
- CHARMANTE BODY FASHIONS LIMITED, TSUEN WAN, HONG KONG:
4,014,961, PUB. 6-7-2011. INT. CL. 25.
- CHARTHOUSE INTERNATIONAL LEARNING CORPORATION, BURNSVILLE, MN:
2,910,468, CANC. INT. CL. 41.
- CHASE PROTECTIVE COATINGS LIMITED, RYE, EAST SUSSEX, UNITED KINGDOM:
4,015,842, PUB. 6-7-2011. INT. CL. 17.
- CHATWOOD, TERESA, SAN ANDREAS, CA:
4,016,765, INT. CL. 3.
- CHAVEY VENTURES, INC., LENEXA, KS:
4,015,539, PUB. 6-7-2011. INT. CL. 35.
- CHAVEZ, EDGAR MATANGUIHAN, PEORIA, AZ, DBA GOT CRUISER?:
4,015,803, PUB. 6-7-2011. INT. CL. 25.
- CHEMALLOY COMPANY, INC., BRYN MAWR, PA:
917,924, REN. 7-18-11. U.S. CL. 1 (INT. CL. 6).
- CHEMICALS EXPORT IMPORT (UK) LIMITED, GREENFORD, MIDDLESEX UB6 0AL, UNITED KINGDOM, DBA WEX CHEMICALS:
2,909,382, CANC. INT. CL. 1.
- CHEMISCHE FABRIK BUDENHEIM KG, FED REP GERMANY:
4,014,604, PUB. 3-22-2011. MULTIPLE CLASS, INT. CLS. 1 AND 5.
- CHEMO IBERICA, S.A., E-08028 BARCELONA, SPAIN:
4,014,635, PUB. 6-7-2011. MULTIPLE CLASS, INT. CLS. 1, 5 AND 42.
- CHEN NAN IRON WIRE CO., LTD., KAOHSIUNG HSIEN, TAIWAN:
2,548,017, REN. 7-16-11. INT. CL. 6.
- CHENG TA LIQUOR CO., LTD., TAINAN HSIEN, TAIWAN:
2,910,949, CANC. INT. CL. 33.
- CHENOWETH & ASSOCIATES, INC., NEW BERN, NC, DBA HEALTH MANAGEMENT ASSOCIATES:
4,015,270, PUB. 6-7-2011. INT. CL. 35.
- CHEUNG YING MAN, TSUEN WAN, N.T., HONG KONG:
4,015,384, PUB. 6-7-2011. INT. CL. 9.
- CHEVAL CREATIVE, LLC, ASPEN, CO:
4,016,746, MULTIPLE CLASS, INT. CLS. 28 AND 41.
- CHEVRON INTELLECTUAL PROPERTY LLC, SAN RAMON, CA:
2,911,674, CANC. INT. CL. 1.
2,911,675, CANC. INT. CL. 1.
- CHI MEDIA GROUP, LLC, LAS VEGAS, NV:
4,017,169, INT. CL. 42.
- CHICAGO COSMETOLOGISTS ASSOCIATION, INC., CHICAGO, IL:
2,486,751, REN. 7-16-11. MULTIPLE CLASS, INT. CLS. 41 AND 42.
- CHICAGO LIMOUSINE, INC., CHICAGO, IL:
4,014,220, PUB. 6-7-2011. INT. CL. 39.
- CHICAGO RESEARCH CHEFS LLC, CHICAGO, IL:
4,014,251, PUB. 6-7-2011. INT. CL. 44.
- CHICAGO'S GREEN CITY MARKET PROGRAM, CHICAGO, IL:
4,014,737, PUB. 6-7-2011. INT. CL. 35.
- CHICAGOLAND ELECTRICAL INDUSTRY CREDIT UNION, WILLOW SPRINGS, IL, AKA CEICU:
4,015,307, PUB. 6-7-2011. INT. CL. 36.
- CHILD FOCUS, INC., CINCINNATI, OH:
2,412,327, CANC. INT. CL. 42.
4,015,231, PUB. 6-7-2011. MULTIPLE CLASS, INT. CLS. 43 AND 44.
- CHINA RESOURCES VANGUARD (HONG KONG) COMPANY LIMITED, WANCHAI, HONG KONG:
4,014,303, PUB. 2-1-2011. MULTIPLE CLASS, INT. CLS.

35, 38, 39, 41, 42 AND 45.
 CHINGIS TECHNOLOGY CORPORATION, SAN JOSE, CA:
 4,016,287, MULTIPLE CLASS, INT. CLS. 35, 40 AND 42.
 CHIPMAN, CATHERINE, BOULDER, CO:
 4,016,575, INT. CL. 3.
 CHO, KYUIN, CANOGA PARK, CA:
 2,909,759, CANC. INT. CL. 9.
 CHOI, BRIAN J, FOLSOM, CA, DBA STUZIO:
 4,015,827, PUB. 6-7-2011. INT. CL. 25.
 CHOY LAY FUT KUNG FU INSTITUTE, INC., SAN FRANCISCO, CA:
 2,412,403, CANC. INT. CL. 41.
 CHRIST CENTERED HOMES, INC., ATLANTA, TX:
 4,017,043, MULTIPLE CLASS, INT. CLS. 35 AND 45.
 CHRISTENSON, CHRIS, SAN MARCOS, CA:
 4,014,265, PUB. 8-18-2009. INT. CL. 25.
 4,014,266, PUB. 8-18-2009. INT. CL. 28.
 CHRISTIAN ART GIFTS, INC., LOMBARD, IL:
 4,016,910, INT. CL. 16.
 CHRISTIAN SUBASHI, WALLINGFORD, PA:
 4,015,006, PUB. 6-7-2011. INT. CL. 30.
 CHRISTINEDARREN INC., PLANTATION, FL:
 4,014,937, PUB. 6-7-2011. INT. CL. 14.
 CHROME HEARTS LLC, HOLLYWOOD, CA:
 2,465,188. REN. 7-18-11. INT. CL. 25.
 CHROMUX TECHNOLOGIES, INC., CHATSWORTH, CA:
 2,911,376, CANC. INT. CL. 9.
 CHRYSLER GROUP LLC, AUBURN HILLS, MI, CHRYSLER CORPORATION, HIGHLAND PARK, MI:
 547,997. REN. 7-19-11. U.S. CL. 19 (INT. CL. 12).
 CHRYSLER GROUP LLC, AUBURN HILLS, MI:
 2,479,010. REN. 7-19-11. INT. CL. 12.
 4,016,624, INT. CL. 12.
 4,016,625, INT. CL. 12.
 4,016,627, INT. CL. 12.
 CHRYSUS CAPITAL MANAGEMENT, LLC, MENLO PARK, CA:
 4,016,866, INT. CL. 36.
 CHUBBY BAITTS, G.P., CARROLLTON, VA:
 2,909,605, CANC. INT. CL. 25.
 CHUMBLEY, JAMES, F., LYNNWOOD, WA:
 4,015,578, PUB. 6-7-2011. INT. CL. 22.
 CHUNNELS, LLC, MOUNT PLEASANT, SC:
 2,909,903, CANC. INT. CL. 35.
 CHURCH DEVELOPMENT FUND, INC., IRVINE, CA:
 2,422,277. REN. 7-21-11. INT. CL. 36.
 CIM GMBH INFORMATIONS UND PRODUKTIONS MANAGEMENT, AACHEN, FED REP GERMANY:
 2,911,631, CANC. MULTIPLE CLASS, INT. CLS. 41 AND 42.
 CIMNET SYSTEMS, INC., INDIANAPOLIS, IN:
 4,015,214, PUB. 6-7-2011. INT. CL. 42.
 CINCINNATI PUBLIC RADIO, INC., CINCINNATI, OH:
 2,465,451. REN. 7-18-11. INT. CL. 41.
 CINDY NELSON, PT, INC, TEMPE, AZ, DBA NELSON PEDIATRIC THERAPY:
 2,559,774. REN. 7-15-11. INT. CL. 42.
 CIRCLE OF BEAUTY, INC., NEW YORK, NY:
 2,413,125, CANC. INT. CL. 3.
 CIRQUENT GMBH, MUNICH, FED REP GERMANY:
 2,909,853, CANC. INT. CL. 35.
 2,909,854, CANC. INT. CL. 42.
 CIT GROUP INC., LIVINGSTON, NJ:
 2,910,182, CANC. INT. CL. 36.
 2,911,458, CANC. INT. CL. 36.
 CITADON, INC., SAN FRANCISCO, CA:
 2,911,397, CANC. INT. CL. 9.
 CITI FINANCIAL LENDING, INC., PEMBROKE PINES, FL:
 4,016,102, PUB. 6-7-2011. INT. CL. 5.
 CITIZENS ALLIANCE BANK, CLARA CITY, MN:
 4,015,134, PUB. 6-7-2011. INT. CL. 36.
 CITRIX SYSTEMS, INC., FORT LAUDERDALE, FL:
 4,016,503, INT. CL. 9.
 CITRUS SPORTS GROUP, LLC, WALTHAM, MA:
 4,016,571, MULTIPLE CLASS, INT. CLS. 25, 38 AND 41.
 CITY OF ARLINGTON, ARLINGTON, TX:
 4,017,329, INT. CL. 45.
 4,017,330, INT. CL. 45.
 4,017,331, INT. CL. 45.
 CITY OF CHESAPEAKE ECONOMIC DEVELOPMENT DEPARTMENT, CHESAPEAKE, VA:
 2,910,084, CANC. INT. CL. 35.
 CITY OF PASADENA, PASADENA, CA:
 2,476,069. REN. 7-18-11. MULTIPLE CLASS, INT. CLS. 6, 21, 25 AND 28.
 CITY OF SACRAMENTO, SACRAMENTO, CA:
 4,015,261, PUB. 6-7-2011. INT. CL. 41.
 CITY TRAILERS, L.L.C., SAGINAW, MI:
 2,911,528, CANC. INT. CL. 12.
 CITYMINT, INC., SAN FRANCISCO, CA:
 4,014,739, PUB. 6-7-2011. INT. CL. 9.
 CJ FOODVILLE CORP., SEOCHO-KU, SEOUL, REPUBLIC OF KOREA:
 2,976,489, AM. INT. CL. 42.
 CKC COMMUNICATIONS, LLC, LOS ANGELES, CA:
 2,910,699, CANC. INT. CL. 35.
 CLARCOR AIR FILTRATION PRODUCTS, INC., JEFFERSONVILLE, IN:
 4,016,498, INT. CL. 11.
 CLARIANT AG, MUTTENZ, SWITZERLAND, SANDOZWANDER, INC., HANOVER, NJ:
 916,118. REN. 7-15-11. U.S. CL. 6 (INT. CL. 1).
 CLARITY WAY, INC., YORK, PA:
 4,015,157, PUB. 6-7-2011. INT. CL. 44.
 CLARKE, CINDY L.E., EDMONTON, ALBERTA, CANADA, DBA OUT OF THE FIRE STUDIO AND WILLETT, JIM L., EDMONTON, ALBERTA, CANADA, DBA OUT OF THE FIRE STUDIO:
 4,017,345, MULTIPLE CLASS, INT. CLS. 9 AND 41.
 CLASSIC BRANDS, LLC, JESSUP, MD:
 4,014,671, PUB. 6-7-2011. INT. CL. 20.
 CLEAN RUN PRODUCTIONS LLC, SOUTH HADLEY, MA:
 2,909,934, CANC. INT. CL. 35.
 CLEAR SIGHT MEDIA, LLC, AUSTIN, TX:
 2,910,662, CANC. INT. CL. 35.
 CLEARCHOICE HOLDINGS LLC, GREENWOOD VILLAGE, CO:
 4,015,937, PUB. 6-7-2011. INT. CL. 44.
 CLEARSNAP HOLDINGS, INC., BURLINGTON, WA:
 2,411,897, CANC. INT. CL. 16.
 CLEARWATER INDUSTRIES, LLC, EUGENE, OR:
 4,015,496, PUB. 6-7-2011. INT. CL. 12.
 CLEARWATER PAPER CORPORATION, SPOKANE, WA:
 4,017,157, INT. CL. 19.
 CLEMENT, TODD R., REXBURG, ID:
 2,910,196, CANC. INT. CL. 29.
 CLEMSON SPORTS MEDICINE AND REHABILITATION, SENECA, SC:
 4,015,872, PUB. 6-7-2011. INT. CL. 44.
 CLEVELAND MACK SALES, INC., CLEVELAND, TX:
 2,474,128. REN. 7-17-11. INT. CL. 12.
 2,474,129. REN. 7-17-11. INT. CL. 39.
 2,474,174. REN. 7-17-11. INT. CL. 12.
 CLEVER HOMES LLC, SAN FRANCISCO, CA:
 2,911,079, CANC. INT. CL. 37.
 CLICKMEIN LIMITED, ROAD TOWN, TORTOLA, BR. VIRGIN ISLANDS:
 4,015,837, PUB. 6-7-2011. INT. CL. 9.
 CLIFFS EDGE, LLC, LAS VEGAS, NV:
 2,910,232, CANC. INT. CL. 37.
 CLIMATE MATTERS HEATING AND AIR CONDITIONING, SANTA CLARA, CA:
 4,015,533, PUB. 6-7-2011. INT. CL. 37.
 CLINICAL COMPUTER SYSTEMS, INC., ELGIN, IL:
 4,015,601, PUB. 6-7-2011. INT. CL. 9.
 CLINVUE LLC, WOODSTOCK, MD:
 4,015,857, PUB. 6-7-2011. INT. CL. 42.
 CLK ASSOCIATES, LLC, ELYRIA, OH:
 3,188,945, COR. INT. CL. 45.
 CLOISTER HONEY, LLC, CHARLOTTE, NC:
 4,015,401, PUB. 6-7-2011. INT. CL. 30.
 CLOR, DAN, LEROY, NY:
 4,015,531, PUB. 6-7-2011. INT. CL. 41.

- CLOSE TRUSTEES (CAYMAN) LIMITED, GRAND CAYMAN, CAYMAN ISLANDS:
2,910,305, CANC. INT. CL. 16.
2,910,307, CANC. INT. CL. 36.
- CLOUD MICROPHONES, TUCSON, AZ:
4,015,666, PUB. 6-7-2011. INT. CL. 9.
- CLOUD 9 WORLD CORP., KEY BISCAYNE, FL:
4,015,969, PUB. 6-7-2011. INT. CL. 25.
- CNC SOFTWARE, INC., TOLLAND, CT:
4,015,189, PUB. 6-7-2011. INT. CL. 41.
- CO-DEPENDENTS ANONYMOUS, INC., PHOENIX, AZ:
4,015,664, PUB. 6-7-2011. MULTIPLE CLASS, INT. CLS. 9, 16 AND 41.
- COAST TO COAST ENTERTAINMENT, LLC, EAST BRUNSWICK, NJ:
2,911,496, CANC. INT. CL. 28.
- COBALT MORTGAGE, INC., KIRKLAND, WA:
4,016,672, INT. CL. 36.
- COBLE, JAMES J., COLUMBIA, SC AND DQC INTERNATIONAL, TAICHUNG, TAIWAN:
4,016,385, INT. CL. 8.
- COBRA FIXATIONS CIE LTEE, MONTREAL, QUEBEC, CANADA:
4,016,395, INT. CL. 20.
- COCA-COLA COMPANY, THE, ATLANTA, GA:
4,014,433, PUB. 5-20-2008. INT. CL. 32.
- COCODRIE PRESS, LLC, NEW ORLEANS, LA:
2,911,510, CANC. INT. CL. 16.
- CODEGEN TECHNOLOGY CO., LTD., LONGGANG DIS, SHENZHEN, CHINA:
4,015,733, PUB. 6-7-2011. INT. CL. 9.
- COFFEE FACTORY, INC., THE, NORTHRIDGE, CA:
2,909,908, CANC. INT. CL. 43.
- COGENT FIBRE INC., TORONTO, ONTARIO, CANADA:
4,015,594, PUB. 6-7-2011. MULTIPLE CLASS, INT. CLS. 4, 31, 35 AND 39.
4,015,596, PUB. 6-7-2011. MULTIPLE CLASS, INT. CLS. 4, 31, 35 AND 39.
- COHEN BROWN PICTURE COMPANY, INC., LOS ANGELES, CA:
2,468,758, REN. 7-15-11. INT. CL. 41.
- COLABS INT'L. CORP., NEWPORT BEACH, CA:
4,015,469, PUB. 6-7-2011. INT. CL. 3.
- COLD KEEPERS L.L.C., THOMASVILLE, GA:
2,578,715, REN. 7-15-11. INT. CL. 21.
- COLGATE-PALMOLIVE COMPANY, NEW YORK, NY:
2,911,719, CANC. INT. CL. 3.
4,016,590, INT. CL. 3.
- COLHOC LIMITED PARTNERSHIP, COLUMBUS, OH, DBA COLUMBUS BLUE JACKETS:
4,014,918, PUB. 6-7-2011. INT. CL. 35.
- COLLECTION BUREAU OF AMERICA, LTD., HAYWARD, CA:
2,477,349, REN. 7-19-11. MULTIPLE CLASS, INT. CLS. 35, 36 AND 41.
- COLLECTIVE TECHNOLOGIES, INC., AUSTIN, TX:
2,417,406, REN. 7-21-11. INT. CL. 42.
- COLLEGIATE TARTAN APPAREL, LLC, GREENSBORO, NC:
4,017,303, MULTIPLE CLASS, INT. CLS. 24 AND 25.
- COLLGARD BIOPHARMACEUTICALS, LTD., PETACH TIKVA, ISRAEL:
2,911,624, CANC. INT. CL. 5.
- COLLIN COUNTY HUMANE SOCIETY, MCKINNEY, TX:
4,017,388, INT. CL. 45.
- COLLINS, CHRIS, GLENFORD, OH:
4,015,543, PUB. 6-7-2011. INT. CL. 41.
- COLLINS, WALTER W., NORTH, SC, DBA BLACKIE COLLINS:
1,625,660, REN. 7-16-11. INT. CL. 8.
- COLOCATION AMERICA CORPORATION, LAS VEGAS, NV:
4,015,962, PUB. 6-7-2011. INT. CL. 42.
- COLOMBO FABIO GIOVANNI FEDELE, I-20137 MILANO, ITALY AND COLOMBO ANTONIO PRIMO, I-20137 MILANO, ITALY:
4,014,583, PUB. 6-7-2011. MULTIPLE CLASS, INT. CLS. 9, 25 AND 28.
- COLON, FELIPE, JERSEY CITY, NJ:
2,911,203, CANC. INT. CL. 16.
- COLORADO NETWORKS, INC., COLORADO SPRINGS, CO:
4,016,603, INT. CL. 9.
- COLORQUICK, LLC, PENNSAUKEN, NJ:
4,016,311, MULTIPLE CLASS, INT. CLS. 39 AND 42.
- COLUMBIA INSURANCE COMPANY, OMAHA, NE:
4,016,899, INT. CL. 19.
- COLUMBIA MUSIC ENTERTAINMENT, INC., JAPAN:
4,014,479, PUB. 6-7-2011. MULTIPLE CLASS, INT. CLS. 9 AND 41.
- COMBISEP, INC., AMES, IA:
2,909,815, CANC. INT. CL. 9.
- COMFORT FOODS, INC., N. ANDOVER, MA:
2,468,692, REN. 7-15-11. INT. CL. 6.
- COMMAND ALKON INCORPORATED, BIRMINGHAM, AL:
2,911,482, CANC. INT. CL. 9.
- COMMERCE AMERICA INC., LAKE SUCCESS, NY:
4,015,167, PUB. 6-7-2011. INT. CL. 28.
- COMMERCE TECHNOLOGIES, INC., ALBANY, NY:
4,015,913, PUB. 6-7-2011. INT. CL. 42.
4,015,919, PUB. 6-7-2011. INT. CL. 42.
4,015,972, PUB. 6-7-2011. INT. CL. 42.
- COMMERCIAL FURNITURE GROUP, INC., ST. LOUIS, MO:
1,173,275, REN. 7-20-11. INT. CL. 20.
- COMMERCIAL PAYMENTS GROUP, LLC, BRENTWOOD, TN:
2,783,997, CANC. INT. CL. 36.
- COMMUNICATION & CONTROL ELECTRONICS LIMITED, GUILDFORD, SURREY GU2 5YQ, UNITED KINGDOM:
2,909,595, CANC. MULTIPLE CLASS, INT. CLS. 9, 16 AND 42.
- COMPAGNIE DE LA FECHE ET DU GOUT, TURCKHEIM, FRANCE:
2,909,725, CANC. INT. CL. 21.
2,909,726, CANC. INT. CL. 21.
- COMPANIA UNIVERSAL TEXTIL S.A., LIMA, PERU:
2,910,446, CANC. INT. CL. 25.
- COMPASS BANCSHARES, INC., BIRMINGHAM, AL:
2,911,271, CANC. INT. CL. 36.
- COMPEFFI LLC, RAMSEY, NJ:
4,015,813, PUB. 6-7-2011. INT. CL. 42.
- COMPUMEDICS LIMITED, AUSTRALIA:
3,899,386, COR. INT. CL. 10.
- COMPUTERS FOR MARKETING CORPORATION, SAN FRANCISCO, CA, DBA CFMC:
4,016,040, PUB. 6-7-2011. INT. CL. 9.
- COMPX SECURITY PRODUCTS INC., DALLAS, TX:
1,154,522, REN. 7-20-11. INT. CL. 6.
- CONAGRA FOODS LAMB WESTON, INC., KENNEWICK, WA:
2,911,398, CANC. INT. CL. 29.
2,911,408, CANC. INT. CL. 30.
2,911,552, CANC. INT. CL. 31.
- CONAGRA FOODS RDM, INC., OMAHA, NE:
1,648,265, REN. 7-16-11. INT. CL. 29.
- CONAGRA FOODS RDM, INC., OMAHA, NE, CREATIVE PRODUCTS INC. OF ROSSVILLE, ROSSVILLE, IL:
1,651,983, REN. 7-18-11. INT. CL. 29.
- CONAGRA FOODS RDM, INC., OMAHA, NE:
2,697,527, CANC. INT. CL. 31.
4,016,427, MULTIPLE CLASS, INT. CLS. 16, 18, 21, 25, 29, 30, 31 AND 32.
- CONAIR CORPORATION, STAMFORD, CT:
4,016,464, INT. CL. 7.
4,016,933, MULTIPLE CLASS, INT. CLS. 9 AND 11.
- CONCAVUS INC., ROUND ROCK, TX:
4,015,886, PUB. 6-7-2011. INT. CL. 9.
- CONCEPT CAPITAL ADVISORS, LLC, GARDEN CITY, NY:
4,015,141, PUB. 6-7-2011. INT. CL. 42.
- CONCUSSION, LLP, FORT WORTH, TX:
4,015,889, PUB. 6-7-2011. INT. CL. 35.
- CONNECTICUT ZONING AND PERMITTING, LLC, HAMDEN, CT:
2,911,165, CANC. INT. CL. 42.

CONNELLY, KAREN J., MINNEAPOLIS, MN:
2,911,610, CANC. INT. CL. 14.

CONSOLIDATED SHOE COMPANY, INC., LYNCHBURG, VA:
4,016,056, PUB. 6-7-2011. INT. CL. 18.
4,016,220, INT. CL. 25.
4,016,221, INT. CL. 18.

CONSORCIO COMEX, S.A. DE C.V., MEXICO, D.F., MEXICO:
2,909,357, CANC. INT. CL. 27.

CONSORZIO PALAZZI - FLORENCE ASSOCIATION FOR INTERNATIONAL EDUCATION, 50121 FLORENCE, ITALY:
4,015,272, PUB. 6-7-2011. INT. CL. 35.

CONSORZIO PER LA TUTELA DEL RAMANDOLO, 33045 NIMIS (UDINE), ITALY:
2,909,431, CANC. INT. CL. 33.

CONSTELLATION ENERGY GROUP, INC., BALTIMORE, MD:
4,017,112, INT. CL. 36.

CONSUMER BENEFIT SERVICES, INC., NAPERVILLE, IL, DBA CBSI:
4,015,825, PUB. 6-7-2011. INT. CL. 45.
4,017,353, INT. CL. 35.

CONSUMER CREDIT COUNSELING SERVICE OF GREATER ATLANTA, INC., ATLANTA, GA:
4,016,799, MULTIPLE CLASS, INT. CLS. 36 AND 41.

CONTIGO SYSTEMS INC., VANCOUVER, CANADA:
4,016,897, INT. CL. 35.

CONTINENCE CENTER OF AMERICA, INC., PEORIA, AZ:
4,017,340, INT. CL. 44.

CONTINENTAL HYDRODYNE SYSTEMS, INC., NORTH CANTON, OH:
2,411,800, CANC. INT. CL. 9.

CONTINENTAL SECURITY INDUSTRIES, SANTA CLARITA, CA:
4,017,225, INT. CL. 9.

CONTRACT MARKETING RESOURCES, L.L.C., CEDAR RAPIDS, IA:
2,910,773, CANC. INT. CL. 35.

CONTRACTORS BONDING AND INSURANCE COMPANY, SEATTLE, WA:
2,467,529, REN. 7-21-11. INT. CL. 36.

CONVAID PRODUCTS, INC., TORRANCE, CA:
4,015,754, PUB. 6-7-2011. INT. CL. 12.

COOKE VENTURES, LLC, STATEN ISLAND, NY, DBA VINTAGE SWEATERS:
4,016,529, INT. CL. 25.

COOL STICK LACROSSE LLC, GLEN ELLYN, IL:
4,015,477, PUB. 6-7-2011. INT. CL. 40.

COOPER SECURE TECHNOLOGIES, LLC, VIENNA, VA:
4,014,387, PUB. 6-7-2011. INT. CL. 19.
4,014,388, PUB. 6-7-2011. INT. CL. 19.
4,014,389, PUB. 6-7-2011. INT. CL. 19.

COOPERATIVA AGRICOLA PISQUERA ELQUI LTDA., VICUNA, CHILE:
2,909,370, CANC. INT. CL. 32.

COPPEL, S.A. DE C.V., CULIACAN, SINALOA, MEXICO:
4,015,538, PUB. 6-7-2011. INT. CL. 36.

CORBOND CORPORATION, BOZEMAN, MT:
2,910,683, CANC. INT. CL. 17.
2,910,684, CANC. INT. CL. 37.
2,910,685, CANC. INT. CL. 41.

CORDICATE IT, BRYN MAWR, PA:
2,909,750, CANC. MULTIPLE CLASS, INT. CLS. 35 AND 42.
2,909,763, CANC. INT. CL. 42.
2,909,802, CANC. MULTIPLE CLASS, INT. CLS. 35 AND 42.

CORDYS SOFTWARE B.V., 3882 RH PUTTEN, NETHERLANDS:
2,910,577, CANC. MULTIPLE CLASS, INT. CLS. 9, 35, 38 AND 42.

CORE 61, INC., ROUND ROCK, TX:
4,017,133, MULTIPLE CLASS, INT. CLS. 10 AND 25.

CORN AND MORE, INC., LINCOLN, NE:
1,427,897, REN. 7-16-11. INT. CL. 42.

CORPORATION OF LLOYD'S, THE, LONDON, EC3M 7HA, UNITED KINGDOM:
2,910,294, CANC. MULTIPLE CLASS, INT. CLS. 36 AND 42.

CORPORATION SERVICE COMPANY, WILMINGTON, DE:
2,911,089, CANC. INT. CL. 42.

CORREAL, EFRAIN, TAMPA, FL:
2,910,951, CANC. INT. CL. 18.

COS INC., NORCO, CA:
4,015,552, PUB. 6-7-2011. INT. CL. 25.

COSMABELLA, INC. CENTER FOR AESTHETIC AND RECONSTRUCTIVE SURGERY, ORLANDO, FL:
2,910,864, CANC. INT. CL. 44.

COSMETICA GENERAL, S.A., BARCELONA, SPAIN:
2,910,498, CANC. INT. CL. 3.

COSSIN, DAVID M, NEW YORK CITY, NY, DBA WONDERGROUND:
4,016,317, INT. CL. 41.

COSTELLO, ANNA, DURHAM, NC:
4,016,015, PUB. 6-7-2011. INT. CL. 35.

COTHRIVE, INC., SMYRNA, GA:
2,910,995, CANC. INT. CL. 35.

COTNER FAMILY ENTERPRISES, LLC, LANCASTER, OH:
2,412,468, CANC. INT. CL. 36.

COTT BEVERAGES INC., TAMPA, FL:
2,911,442, CANC. INT. CL. 32.

COTTONWOOD HILLS, LLC, SCOTTSDALE, AZ:
2,911,174, CANC. INT. CL. 37.

COUGHLAN COMPANIES, INC., MANKATO, MN:
4,016,973, MULTIPLE CLASS, INT. CLS. 9, 41 AND 42.

COUNCIL FOR ADULT AND EXPERIENTIAL LEARNING, CHICAGO, IL:
4,015,756, PUB. 6-7-2011. INT. CL. 41.

COUNCIL FOR ENTREPRENEURIAL DEVELOPMENT, RESEARCH TRIANGLE PARK, NC:
2,910,846, CANC. INT. CL. 41.

COUNCIL FOR THE VAIL-LEAVITT MUSIC HALL, INC., RIVERHEAD, NY:
4,014,422, PUB. 6-7-2011. INT. CL. 36.

COUNCIL GAMES, GRAND JUNCTION, CO:
4,017,055, INT. CL. 28.

COURSEBROWSER.COM, NEW YORK, NY:
2,910,791, CANC. INT. CL. 35.

COURTROOM TELEVISION NETWORK LLC, NEW YORK, NY:
2,910,616, CANC. INT. CL. 42.

COUSTEAU SOCIETY, INC., THE, CHESAPEAKE, VA:
1,631,391, REN. 7-18-11. MULTIPLE CLASS, INT. CLS. 9, 14, 16, 25, 28 AND 42.

COVENANT CLASSICAL SCHOOLS, LLC, HOOVER, AL:
4,014,802, PUB. 6-7-2011. MULTIPLE CLASS, INT. CLS. 41 AND 43.

COVENTRY HEALTH CARE, INC., BETHESDA, MD:
2,910,216, CANC. MULTIPLE CLASS, INT. CLS. 36 AND 44.

COVER-ALL, INC., CHATSWORTH, CA:
2,911,485, CANC. INT. CL. 37.

COX AUTO TRADER, L.L.C., ATLANTA, GA:
2,909,955, CANC. INT. CL. 16.

COX COMMUNICATIONS, INC., ATLANTA, GA:
2,911,456, CANC. INT. CL. 38.

COX HOLDINGS, INC., ATLANTA, GA:
2,480,044, REN. 7-15-11. INT. CL. 38.

COYLE, TODD, FRAZIER PARK, CA:
4,014,371, PUB. 6-7-2011. INT. CL. 25.

COZY HOMESTEAD PUBLISHING, INC., SWANTON, OH:
2,413,169, CANC. INT. CL. 16.

CPM DEVELOPMENT CORPORATION, SPOKANE, WA:
4,015,240, PUB. 6-7-2011. INT. CL. 19.
4,015,241, PUB. 6-7-2011. INT. CL. 19.

CR TRADING COMPANY, INC., LOS ANGELES, CA, DBA TOP FRAGRANCES CORPORATION:
4,015,478, PUB. 6-7-2011. INT. CL. 3.

CRADLE LIMITED LIABILITY COMPANY, JAPAN:
4,014,573, PUB. 6-7-2011. INT. CL. 9.

CRANE COMPOSITES, INCORPORATED, CHANNAHON, IL:
2,909,622, CANC. INT. CL. 19.

- CRATECH, INC., TAHOKA, TX:
4,015,378, PUB. 6-7-2011. INT. CL. 42.
- CRAWFORD & COMPANY, ATLANTA, GA:
4,016,835, INT. CL. 36.
4,017,008, MULTIPLE CLASS, INT. CLS. 36 AND 41.
- CRAZY PET, LLC, AZUSA, CA:
2,473,090, REN. 7-16-11. INT. CL. 25.
- CRAZY WOMAN CONCEPTS, INC., CODY, WY:
4,017,163, INT. CL. 35.
- CREATIVE PERSPECTIVES, INC., CHARLOTTESVILLE, VA:
2,442,020, REN. 7-19-11. MULTIPLE CLASS, INT. CLS. 35 AND 42.
- CREATIVE SOLUTIONS UNLIMITED, INC., SHEFFIELD, IA:
2,909,743, CANC. INT. CL. 9.
- CREDIT KARMA, SAN FRANCISCO, CA:
4,014,356, PUB. 5-4-2010. INT. CL. 35.
- CREDIT UNION ONE, FERNDALE, MI:
2,910,450, CANC. INT. CL. 36.
- CREDITRON FINANCIAL SERVICES, INC., ERIE, PA:
2,910,822, CANC. INT. CL. 36.
- CREEKSIDE BIBLE CHURCH OF MONTGOMERY COUNTY, TEXAS, SPRING, TX:
4,015,592, PUB. 6-7-2011. INT. CL. 45.
- CRESCENT SYSTEMS, LLC, COUNCIL BLUFF, IA:
2,474,399, REN. 7-15-11. INT. CL. 36.
- CRESTHILL SUITES COMPANY, LLC, LIVERPOOL, NY:
2,412,866, CANC. INT. CL. 42.
- CRISTT'S ART CORNER, SANDERSVILLE, GA:
2,909,822, CANC. INT. CL. 25.
- CRITICAL PATH TRAINING, LLC, JACKSONVILLE, FL:
4,014,351, PUB. 4-20-2010. INT. CL. 41.
- CRO-BAR, L.L.C., KINGSPORT, TN:
4,015,084, PUB. 6-7-2011. INT. CL. 43.
4,015,085, PUB. 6-7-2011. INT. CL. 29.
4,015,088, PUB. 6-7-2011. INT. CL. 43.
4,015,092, PUB. 6-7-2011. INT. CL. 30.
- CROSCILL HOME LLC, NEW YORK, NY:
4,016,610, MULTIPLE CLASS, INT. CLS. 20, 21, 24 AND 27.
- CROSMAN CORPORATION, BLOOMFIELD, NY:
4,016,844, INT. CL. 13.
- CROWDER CONSTRUCTION COMPANY, CHARLOTTE, NC:
2,464,920, REN. 7-21-11. INT. CL. 37.
- CROWDRISE, LLC, HUNTINGTON WOODS, MI:
4,015,725, PUB. 6-7-2011. INT. CL. 35.
4,015,920, PUB. 6-7-2011. MULTIPLE CLASS, INT. CLS. 25 AND 35.
- CROWDSTAR INTERNATIONAL LIMITED, BLACKROCK, CO. DUBLIN, IRELAND:
4,017,107, INT. CL. 41.
- CROWN FINANCIAL MINISTRIES, INC., LAWRENCEVILLE, GA:
4,016,569, INT. CL. 36.
4,016,570, INT. CL. 38.
- CRUISE LINES INTERNATIONAL ASSOCIATION, INC., FORT LAUDERDALE, FL:
4,015,550, PUB. 6-7-2011. INT. CL. 41.
4,015,553, PUB. 6-7-2011. INT. CL. 41.
4,015,558, PUB. 6-7-2011. INT. CL. 35.
4,015,562, PUB. 6-7-2011. INT. CL. 35.
- CRUZAN VIRIL LTD., FREDERIKSTED, ST. CROIX, US VIRGIN ISLANDS:
2,909,502, CANC. INT. CL. 33.
- CRYOVAC, INC., ELMWOOD PARK, NJ:
2,910,443, CANC. MULTIPLE CLASS, INT. CLS. 7, 17, 40 AND 42.
- CRYSTAL ICING, LLC, ROCHESTER, NY:
4,015,165, PUB. 6-7-2011. INT. CL. 14.
4,015,166, PUB. 6-7-2011. INT. CL. 40.
- CRYSTAL N. YEE, OLNEY, MD, DBA FOOTPRINTS DEVELOPMENT CENTER:
4,015,338, PUB. 6-7-2011. INT. CL. 43.
- CSAFE, LLC, DAYTON, OH:
4,014,241, PUB. 6-7-2011. INT. CL. 41.
- CSG SYSTEMS, INC., ENGLEWOOD, CO:
2,412,900, CANC. INT. CL. 9.
- CSL BEHRING L.L.C., KING OF PRUSSIA, PA:
2,909,550, CANC. MULTIPLE CLASS, INT. CLS. 36 AND 44.
- CSM BAKERY PRODUCTS NA, INC., TUCKER, GA:
4,016,449, MULTIPLE CLASS, INT. CLS. 16, 21, 29 AND 30.
- CSSN INC DBA CARD SCANNING SOLUTIONS, LOS ANGELES, CA:
2,910,440, CANC. INT. CL. 9.
- CTR NEWS, LLC, MESA, AZ:
4,016,417, MULTIPLE CLASS, INT. CLS. 38 AND 41.
- CULINARY DEVELOPMENT GROUP, INC., AKRON, OH:
2,461,386, REN. 7-19-11. INT. CL. 30.
- CULTURAL ASSET MANAGEMENT, INC., LOS ANGELES, CA:
4,014,430, PUB. 5-18-2010. MULTIPLE CLASS, INT. CLS. 16 AND 44.
- CULTURENIK PUBLISHING, INC., STROUDSBURG, PA:
4,014,881, PUB. 6-7-2011. INT. CL. 14.
4,014,883, PUB. 6-7-2011. INT. CL. 16.
4,014,884, PUB. 6-7-2011. INT. CL. 21.
4,014,885, PUB. 6-7-2011. INT. CL. 9.
4,014,894, PUB. 6-7-2011. INT. CL. 28.
- CUNA MUTUAL INSURANCE SOCIETY, MADISON, WI:
2,563,402, REN. 7-15-11. INT. CL. 36.
- CUNINGHAM GROUP ARCHITECTURE, P.A., MINEAPOLIS, MN:
2,481,167, REN. 7-16-11. INT. CL. 42.
2,481,167, CANC. INT. CL. 37.
- CUNNINGHAM PONTIAC-BUICK-GMC TRUCKS, INC., SPRINGFIELD, TN:
2,411,969, CANC. INT. CL. 35.
- CURRENT ENVIRONMENTAL SOLUTIONS, L.L.C., RICHLAND, WA:
2,909,628, CANC. INT. CL. 40.
- CUSTOM AGRICULTURAL FORMULATORS, FRESNO, CA, DBA CUSTOM AG FORMULATORS:
2,910,040, CANC. INT. CL. 1.
- CUSTOM DATA SOLUTIONS, ROMEO, MI:
2,910,587, CANC. MULTIPLE CLASS, INT. CLS. 9 AND 35.
- CW HOTEL LIMITED PARTNERSHIP, CRESTVIEW HILLS, KY, DBA CWGP LIMITED PARTNERSHIP:
2,476,163, REN. 7-19-11. INT. CL. 42.
- CYBATROL, INC., LAS VEGAS, NV:
4,016,281, INT. CL. 35.
- CYBERDEL SERVICE CORPORATION, PARSIPPANY, NJ:
2,909,949, CANC. INT. CL. 41.
- CYBERPULSE L.L.C., HIGHLAND PARK, IL:
2,461,913, REN. 7-18-11. INT. CL. 9.
- CYVEX NUTRITION, INC., IRVINE, CA:
2,443,277, REN. 7-15-11. INT. CL. 5.
- C3 BRANDS, INC., NEW YORK, NY:
2,910,160, CANC. INT. CL. 33.
- D. TANK, INC., SUN VALLEY, CA:
2,531,474, REN. 7-15-11. MULTIPLE CLASS, INT. CLS. 37 AND 42.
- D.A.R.E. AMERICA, INGLEWOOD, CA:
2,491,872, REN. 7-19-11. MULTIPLE CLASS, INT. CLS. 6 AND 14.
- D.P. TEXTILE & APPAREL, INC., LOS ANGELES, CA:
2,910,094, CANC. INT. CL. 25.
- D-FY-IT, INC., MIAMI, FL:
2,561,633, REN. 7-19-11. INT. CL. 42.
- D-M-S HOLDINGS, INC., WAUKEGAN, IL:
2,458,954, REN. 7-15-11. MULTIPLE CLASS, INT. CLS. 5, 8, 10 AND 12.
- D'ADDARIO & COMPANY, INC., FARMINGDALE, NY:
1,652,332, REN. 7-16-11. INT. CL. 15.
- D'ORAZIO FOODS, INC., BELLMAWR, NJ:
4,015,955, PUB. 6-7-2011. INT. CL. 30.
- DACHIS GROUP ARCHIVAL ACQUISITION SUB, LLC, LINCOLN, NE:
2,412,146, CANC. INT. CL. 42.
- DAHDOUL TEXTILES, COMMERCE, CA:
4,015,492, PUB. 6-7-2011. INT. CL. 35.

DAIMLER AG, STUTTGART, FED REP GERMANY, DAIMLERCHRYSLER AG, STUTTGART, FED REP GERMANY: 2,464,810. REN. 7-18-11. INT. CL. 12.

DAIMLER AG, STUTTGART, FED REP GERMANY: 4,015,065, PUB. 6-7-2011. MULTIPLE CLASS, INT. CLS. 9, 12 AND 27.

DAIMLER TRUCKS NORTH AMERICA LLC, PORTLAND, OR: 2,475,922. REN. 7-15-11. INT. CL. 12.

DALBAR, INC., BOSTON, MA: 2,911,315, CANC. INT. CL. 35.

DALTON ENTERPRISES, INC., CHESHIRE, CT: 4,017,350, INT. CL. 19.

DAN MAR CO., ARLINGTON, TX: 4,014,684, PUB. 6-7-2011. INT. CL. 41.

DANA LIMITED, MAUMEE, OH: 4,015,844, PUB. 6-7-2011. INT. CL. 12.

DANCERS CARE FOUNDATION, INC., LANOKA HARBOR, NJ: 4,015,476, PUB. 6-7-2011. INT. CL. 36.

DANE-ELEC MEMORY, FRANCE: 4,014,522, PUB. 6-7-2011. INT. CL. 9.

DANIEL DEFENSE, INC., BLACK CREEK, GA: 4,015,736, PUB. 6-7-2011. INT. CL. 13.

4,015,738, PUB. 6-7-2011. INT. CL. 13.

DANIELA VERONICA GUSA DE DRAGAN, ITALY: 4,014,566, PUB. 6-7-2011. INT. CL. 41.

DARBY DENTAL SUPPLY, LLC, JERICHO, NY: 4,017,184, INT. CL. 10.

DARLING INTERNATIONAL INC., IRVING, TX: 4,017,021, INT. CL. 37.

4,017,023, INT. CL. 37.

DARLINGTON COOKIE COMPANY, NOBLESVILLE, IN: 3,990,443, COR. INT. CL. 29.

DARRYL BRADLEY, GLENSIDE, PA AND CHANTE M. BRADLEY, GLENSIDE, PA: 4,015,099, PUB. 6-7-2011. INT. CL. 41.

DART INDUSTRIES INC., ORLANDO, FL: 4,015,575, PUB. 6-7-2011. INT. CL. 44.

4,016,057, PUB. 6-7-2011. INT. CL. 21.

DATA CENTRUM COMMUNICATIONS, INC., PARAMUS, NJ: 2,499,618. REN. 7-16-11. INT. CL. 16.

2,501,407. REN. 7-16-11. INT. CL. 16.

DATABANK DATA SERVICES, LLC, AUSTIN, TX: 4,015,280, PUB. 6-7-2011. MULTIPLE CLASS, INT. CLS. 42 AND 45.

DATAACURE INC., ANNANDALE, VA: 2,570,280. REN. 7-18-11. INT. CL. 42.

DATAFAB SYSTEMS, INC., TAOYUAN COUNTY, TAIWAN: 4,015,875, PUB. 6-7-2011. INT. CL. 9.

DAVE ANDERSON CORPORATION, THE, LOS ALTOS, CA: 2,429,777, COR. INT. CL. 16.

DAVESARTS INDUSTRIES LLC, NEW YORK, NY: 4,016,335, INT. CL. 9.

DAVID CHAMBERLAIN, UNITED KINGDOM: 4,014,490, PUB. 6-7-2011. MULTIPLE CLASS, INT. CLS. 9 AND 21.

DAVID MUNSTERMAN, LOS MOLINOS, CA: 4,015,519, PUB. 6-7-2011. INT. CL. 35.

DAVID TEXTILES, INC., CITY OF COMMERCE, CA: 4,014,211, PUB. 6-7-2011. INT. CL. 24.

DAVID, PAUL, KUTZTOWN, PA: 4,014,394, PUB. 6-7-2011. MULTIPLE CLASS, INT. CLS. 35 AND 41.

DAVIS PHINNEY FOUNDATION, BOULDER, CO: 4,016,001, PUB. 6-7-2011. MULTIPLE CLASS, INT. CLS. 36 AND 41.

DAVIS, KEITH, BEVERLY HILLS, CA: 4,014,272, PUB. 6-7-2011. INT. CL. 25.

DAVIS, MARGARET L., LOS ANGELES, CA: 2,911,334, CANC. INT. CL. 26.

DAVISON OIL COMPANY, INC., MOBILE, AL: 2,954,526, CANC. INT. CL. 1.

DAVITA INC., DENVER, CO: 4,016,256, MULTIPLE CLASS, INT. CLS. 16, 36 AND 44.

DAWNBREAKER, INC., ROCHESTER, NY: 4,015,900, PUB. 6-7-2011. INT. CL. 35.

DAY, JOHN, FOREST HILLS, NY: 4,015,751, PUB. 6-7-2011. INT. CL. 25.

DAYMON INTERACTIONS INC., STAMFORD, CT: 4,014,960, PUB. 6-7-2011. INT. CL. 35.

DAYTON HUDSON CORPORATION, MINNEAPOLIS, MN TO TARGET BRANDS, INC., MINNEAPOLIS, MN: 2,075,835, AM. INT. CL. 25.

DBS COMMUNICATIONS, INC., SCHAUMBURG, IL: 2,910,460, CANC. INT. CL. 38.

DC COMICS, NEW YORK, NY: 1,146,243. REN. 7-19-11. INT. CL. 28.

DCAST, LLC, HILTON HEAD ISLAND, SC: 4,014,383, PUB. 6-7-2011. MULTIPLE CLASS, INT. CLS. 9, 38 AND 42.

DCL INTERNATIONAL INC., CONCORD, ONTARIO, CANADA: 2,909,463, CANC. INT. CL. 7.

DDS SOLUTIONS LLC, MORGANTOWN, WV: 4,017,338, INT. CL. 35.

DE HASKE (INTERNATIONAL) AG, CH-6332 HAGEN-DORN, SWITZERLAND: 2,412,289, CANC. MULTIPLE CLASS, INT. CLS. 9, 16, 35 AND 41.

DE MEO, LORENZA, 00167 ROME, ITALY: 2,910,259, CANC. INT. CL. 9.

DEALNATION, INC, DENVER, CO: 4,015,456, PUB. 6-7-2011. INT. CL. 35.

DEAN INTELLECTUAL PROPERTY SERVICES, INC., DALLAS, TX, BEATRICE CREAMERY COMPANY, CHICAGO, IL: 285,893. REN. 7-19-11. U.S. CL. 46 (INT. CL. 29).

DEAN INTELLECTUAL PROPERTY SERVICES, INC., DALLAS, TX: 2,910,465, CANC. INT. CL. 35.

DEARBORN MID-WEST CONVEYOR CO., TAYLOR, MI: 2,412,239, CANC. MULTIPLE CLASS, INT. CLS. 37 AND 42.

DEBARDLABON, DESMOND, CHICAGO, IL: 2,910,254, CANC. INT. CL. 16.

DEBORAH S. HOWELL, LAS VEGAS, NV: 4,014,886, PUB. 6-7-2011. INT. CL. 41.

DECARAVA, SHERRY TURNER, BROOKLYN, NY: 4,016,467, INT. CL. 16.

DEEP FOODS, INC., UNION, NJ: 4,014,900, PUB. 6-7-2011. INT. CL. 29.

DEEP RIVER PARTNERS LTD., MILWAUKEE, WI: 2,412,532, CANC. INT. CL. 42.

2,412,533, CANC. INT. CL. 42.

DEEPAK PRODUCTS, INC., MIAMI, FL: 2,479,900. REN. 7-19-11. INT. CL. 5.

DEER CREEK CORPORATE SERVICES, INC., HELENA, MT: 4,015,639, PUB. 6-7-2011. INT. CL. 45.

DEHART, LESLIE, MARTINEZ, CA: 2,910,581, CANC. INT. CL. 37.

DEHN + SOHNE GMBH & CO. KG, 92306 NEUMARKT/OPF., FED REP GERMANY: 2,464,543. REN. 7-15-11. INT. CL. 9.

2,464,544. REN. 7-15-11. INT. CL. 9.

DEIRDRE KENNEDY, SAN FRANCISCO, CA, DBA THE EYES OF EVE: 4,015,228, PUB. 6-7-2011. INT. CL. 14.

DEL MONTE CORPORATION, PITTSBURGH, PA: 732,817, CANC. U.S. CL. 46.

DEL MONTE CORPORATION, SAN FRANCISCO, CA: 2,482,789. REN. 7-18-11. INT. CL. 42.

DELEGATA CORPORATION, SACRAMENTO, CA: 4,015,050, PUB. 6-7-2011. INT. CL. 38.

DELISSE, H. PETER, PIERMONT, NY: 2,909,388, CANC. INT. CL. 41.

DELO INDUSTRIAL ADHESIVES LLC, HAUPPAUGE, NY: 4,015,010, PUB. 6-7-2011. INT. CL. 1.

DELRAY PLANTS CO, VENUS, FL: 4,016,011, PUB. 6-7-2011. INT. CL. 21.

DELTA GREEN, MADERA, CA: 4,016,867, INT. CL. 33.

DELTA PHI LAMBDA SORORITY, INC., CHARLOTTE, NC: 4,014,887, PUB. 6-7-2011. INT. CL. 35.

- DELUXE ENTERPRISE OPERATIONS, INC., SHOREVIEW, MN:
2,467,747. REN. 7-21-11. INT. CL. 35.
- DEMATIC CORP., GRAND RAPIDS, MI:
2,466,427. REN. 7-18-11. INT. CL. 9.
- DENIM PROJECT LLC, NEW YORK, NY:
4,016,318. INT. CL. 25.
- DENNIS KENTCH, LAKE HAVASU, AZ:
4,015,618. PUB. 6-7-2011. INT. CL. 11.
- DENTAL HEALTH PROGRAMS, INC., DALLAS, TX:
2,910,115. CANC. INT. CL. 44.
2,910,125. CANC. INT. CL. 44.
- DEPARTMENT OF DEFENSE, WASHINGTON, DC:
4,017,042. MULTIPLE CLASS, INT. CLS. 35 AND 41.
- DEPARTMENT OF THE TREASURY, UNITED STATES MINT, WASHINGTON, DC:
4,015,659. PUB. 6-7-2011. INT. CL. 14.
- DEPARTMENT OF VETERANS AFFAIRS, WASHINGTON, DC:
4,015,352. PUB. 5-3-2011. INT. CL. 44.
- DERMOCOSMETICA INCORPORATION, JUNGSHAN CHIU, TAIPEI, TAIWAN:
2,412,791. CANC. INT. CL. 3.
- DERN, KURT, 35415 POHLHEIM-GRUNINGEN, FED REP GERMANY:
2,909,825. CANC. MULTIPLE CLASS, INT. CLS. 29, 30, 35 AND 43.
- DERUNGS LICHT AG, 9202 GOSSAU, SWITZERLAND:
2,460,081. REN. 7-18-11. INT. CL. 11.
2,468,323. REN. 7-17-11. INT. CL. 11.
- DES-SYN, INC., ATLANTA, GA:
4,016,704. MULTIPLE CLASS, INT. CLS. 16 AND 42.
- DESERT GLORY, LTD., SAN ANTONIO, TX:
4,014,700. PUB. 6-7-2011. INT. CL. 31.
- DESORMEAUX, CHARLES, CHICAGO, IL:
4,014,899. PUB. 6-7-2011. MULTIPLE CLASS, INT. CLS. 9 AND 41.
- DETROIT DERBY GIRLS 2007 LLC, LIVONIA, MI:
4,014,861. PUB. 6-7-2011. MULTIPLE CLASS, INT. CLS. 25 AND 41.
- DETROIT ENTERTAINMENT, L.L.C., DETROIT, MI:
4,016,233. MULTIPLE CLASS, INT. CLS. 41 AND 43.
4,016,234. MULTIPLE CLASS, INT. CLS. 41 AND 43.
- DEUTSCHE POST AG, 53113 BONN, FED REP GERMANY:
2,909,409. CANC. MULTIPLE CLASS, INT. CLS. 16, 35 AND 36.
2,910,249. CANC. MULTIPLE CLASS, INT. CLS. 16, 25, 28, 36 AND 42.
- DEUTSCHE TELEKOM AG, 53113 BONN, FED REP GERMANY:
2,459,405. REN. 7-16-11. MULTIPLE CLASS, INT. CLS. 9, 37 AND 38.
2,914,146. CANC. MULTIPLE CLASS, INT. CLS. 9, 16, 35, 36, 38, 39, 41 AND 42.
- DEUTSCHE TELEKOM AG, BONN, FED REP GERMANY:
2,914,539. CANC. INT. CL. 16.
- DEYO, INC., GROVER BEACH, CA:
4,015,516. PUB. 6-7-2011. INT. CL. 25.
- DIAGEO NORTH AMERICA, INC., NORWALK, CT:
4,016,971. INT. CL. 33.
- DIAGNOCURE INC., SAINTE-FOY, QUEBEC, CANADA:
2,909,453. CANC. INT. CL. 5.
- DIALYSIS CLINIC, INC., NASHVILLE, TN, AKA DCI:
4,015,048. PUB. 6-7-2011. INT. CL. 44.
- DIAMINTANGIBLES INTERNATIONAL, LTD., NASSAU, BAHAMAS:
4,016,479. INT. CL. 14.
- DIAMOND WIPES INTERNATIONAL, CHINO, CA:
4,017,067. MULTIPLE CLASS, INT. CLS. 3 AND 5.
- DIAMOND, NICOLE, BOSTON, MA AND DIAMOND, AARON, BOSTON, MA:
4,015,880. PUB. 6-7-2011. INT. CL. 35.
- DICHTOMATIK AMERICAS, L.P., SHAKOPEE, MN:
4,014,692. PUB. 6-7-2011. INT. CL. 17.
- DICKHOUT, CRAIG A, HUNTINGTON BEACH, CA:
4,016,411. INT. CL. 35.
- DIERDRE WALLACE, SAN FRANCISCO, CA, DBA DEE-FIND:
4,016,621. INT. CL. 25.
- DIGI-KEY CORPORATION, THIEF RIVER FALLS, MN:
4,014,912. PUB. 6-7-2011. MULTIPLE CLASS, INT. CLS. 6, 9, 17 AND 35.
- DIGILIFE LTD., AUSTIN, TX:
4,016,206. INT. CL. 9.
- DIGITAL NEXUS TECHNOLOGIES, INC., FOOTHILL RANCH, CA:
4,015,058. PUB. 6-7-2011. INT. CL. 42.
4,015,059. PUB. 6-7-2011. INT. CL. 42.
- DIGITAL POWER CORPORATION, FREMONT, CA:
2,910,265. CANC. MULTIPLE CLASS, INT. CLS. 40 AND 42.
- DILLON, THOMAS W, SAN TAN VALLEY, AZ:
4,016,772. INT. CL. 28.
- DIRECT STOCK, INC., NEW YORK, NY:
2,910,990. CANC. INT. CL. 35.
- DISCERN GROUP, INC., MOUNTAIN VIEW, CA:
4,016,700. MULTIPLE CLASS, INT. CLS. 35, 36 AND 42.
- DISCFLO CORPORATION, SANTEE, CA:
4,014,810. PUB. 6-7-2011. INT. CL. 7.
- DISCOS FUENTES EDIMUSICA, S.A., MEDELLIN, COLOMBIA:
2,469,702. REN. 7-15-11. INT. CL. 9.
- DISNEY ENTERPRISES, INC., BURBANK, CA, WALT DISNEY PRODUCTIONS, BURBANK, CA:
1,189,727. REN. 7-18-11. MULTIPLE CLASS, INT. CLS. 6, 16, 21, 41 AND 42.
- DISNEY ENTERPRISES, INC., BURBANK, CA:
2,412,790. CANC. INT. CL. 41.
2,911,392. CANC. INT. CL. 28.
4,016,707. INT. CL. 28.
- DISTRESSED PROPERTY INSTITUTE, LLC, AUSTIN, TX:
4,014,407. PUB. 1-4-2011. INT. CL. 36.
4,014,408. PUB. 1-4-2011. INT. CL. 35.
- DISTRIBUTOR OPERATIONS, INC., DALLAS, TX:
2,494,302. REN. 7-16-11. INT. CL. 9.
- DIVA ROSES, INC., MIAMI, FL:
4,016,745. INT. CL. 35.
- DIVAS GONE WILD DESIGNS AND MORE, INC, METAIRIE, LA:
4,014,218. PUB. 6-7-2011. INT. CL. 25.
- DIVERSEY, INC., STURTEVANT, WI, S. C. JOHNSON & SON, INC., RACINE, WI:
1,644,915. REN. 7-19-11. INT. CL. 5.
- DIVINE DIRECTIONS, DUNNELLON, FL:
2,412,326. CANC. MULTIPLE CLASS, INT. CLS. 14 AND 25.
- DIVISON SALES US LLC., DES PLAINES, IL:
2,910,652. CANC. INT. CL. 35.
- DIX JAXON PRODUCTS CO., INC., DAYTON, OH:
1,195,309. REN. 7-18-11. INT. CL. 30.
- DIXON TICONDEROGA COMPANY, HEATHROW, FL:
913,582. REN. 7-16-11. U.S. CL. 37 (INT. CL. 16).
- DML MARKETING GROUP, LTD., VAN NUYS, CA:
2,413,000. CANC. INT. CL. 25.
- DOCUCORP INTERNATIONAL, INC., DALLAS, TX:
2,909,381. CANC. MULTIPLE CLASS, INT. CLS. 9 AND 42.
- DOCUMENTUM, INC., PLEASANTON, CA:
2,911,366. CANC. INT. CL. 9.
- DOE GEAR, LLC, CLINTON TOWNSHIP, MI:
4,016,592. INT. CL. 25.
- DOLBY LABORATORIES LICENSING CORPORATION, SAN FRANCISCO, CA:
1,649,027. REN. 7-20-11. INT. CL. 37.
- DOLLAR GENERAL CORPORATION, GOODLETTSVILLE, TN:
2,412,180. CANC. INT. CL. 25.
- DOLLAR RENT A CAR, INC., TULSA, OK:
2,910,037. CANC. INT. CL. 39.
- DON GIFFELS, DENVER, CO:
4,016,016. PUB. 6-7-2011. INT. CL. 42.
- DON'T THINK TWICE MEDIA, INC., NEW YORK, NY:
2,911,319. CANC. INT. CL. 25.

DONALD DANFORTH PLANT SCIENCE CENTER, ST. LOUIS, MO:
2,462,377. REN. 7-21-11. INT. CL. 42.

DONELY, JADANA, OCEANSIDE, CA, DBA RED CARPET EVENT PLANNING:
4,016,655. INT. CL. 41.

DONG GUAN TR BEARINGS CO., LTD, DONG GUAN, GUANGDONG, CHINA, GUANGDONG MACHINERY & EQUIPMENT & IMPORT & EXPORT CORPORATION, GUANGZHOU, CHINA:
1,641,044. REN. 7-15-11. INT. CL. 7.

DONGBU STEEL CO., LTD., SEO-KU, INCHON, REPUBLIC OF KOREA:
4,015,720. PUB. 6-7-2011. INT. CL. 6.

DONGFENG-FUJI-THOMSON THERMOSTAT CO., LTD., CHINA:
4,014,617. PUB. 6-7-2011. INT. CL. 9.

DOPSON, JAY, MONROE, LA:
2,910,519. CANC. INT. CL. 37.

DOREL JUVENILE GROUP, INC., FOXBORO, MA:
4,016,416. INT. CL. 19.

DORIC PRODUCTS, INC., MARSHALL, IL:
2,517,054. REN. 7-16-11. INT. CL. 19.
2,517,055. REN. 7-16-11. INT. CL. 19.
2,517,056. REN. 7-16-11. INT. CL. 19.
2,524,772. REN. 7-19-11. INT. CL. 19.

DOT HILL SYSTEMS CORP., LONGMONT, CO, SILICON ALLEY TECHNOLOGIES, INC., WILMINGTON, DE:
2,520,739. REN. 7-18-11. INT. CL. 9.

DOTOMI, INC., CHICAGO, IL:
4,016,380. INT. CL. 35.

DOTS, LLC, GLENWILLOW, OH:
4,017,263. INT. CL. 3.

DOUGLAS COMPANY, INC., KEENE, NH:
4,014,844. PUB. 6-7-2011. INT. CL. 28.
4,016,065. PUB. 6-7-2011. INT. CL. 28.
4,016,066. PUB. 6-7-2011. INT. CL. 28.

DOUMITH, DAVID, FORT DE FRANCE, FRANCE:
4,014,252. PUB. 6-7-2011. MULTIPLE CLASS, INT. CLS. 9 AND 11.

DOVEX CORPORATION, KIRKLAND, WA:
1,699,371. REN. 7-20-11. INT. CL. 35.

DOWN RIGHT LTD., BROOKLYN, NY:
4,016,103. PUB. 7-19-2011. INT. CL. 24.

DOWN TO EARTH DESIGNS, INC., PORTLAND, OR:
4,014,761. PUB. 6-7-2011. INT. CL. 3.

DPAC TECHNOLOGIES CORP., HUDSON, OH:
2,911,378. CANC. INT. CL. 9.

DPZ PROPERTIES, INC., DURHAM, NC:
4,016,617. INT. CL. 35.

DR GLOBALDIRECT, INC., EDEN PRAIRIE, MN:
2,910,312. CANC. INT. CL. 35.

DR. IHDE DENTAL AG, SWITZERLAND:
4,014,449. PUB. 4-15-2008. INT. CL. 10.

DR. MED. AUFDERMAUR AG, 5426 LENGNAU, SWITZERLAND:
2,471,652. REN. 7-16-11. MULTIPLE CLASS, INT. CLS. 5 AND 30.

DR. MICHAEL KAPLAN, D.O., P.C., SMITHTOWN, NY:
2,910,020. CANC. INT. CL. 44.

DR. TATTOFF, INC., BEVERLY HILLS, CA:
4,015,229. PUB. 6-7-2011. INT. CL. 44.

DRAPER, INC., SPICELAND, IN:
716,795. REN. 7-15-11. U.S. CL. 22 (INT. CL. 28).

DRATH, TOM, W., PARADISE VALLEY, AZ:
4,016,008. PUB. 6-7-2011. INT. CL. 41.

DREAM USA, INC, LOS ANGELES, CA:
2,910,166. CANC. INT. CL. 25.

DREAM USA, INC., LOS ANGELES, CA:
2,910,165. CANC. INT. CL. 25.

DREAMLAND HOLDING COMPANY, LLC, BIRMINGHAM, AL:
2,531,648. REN. 7-15-11. INT. CL. 42.
2,531,648. COR. INT. CL. 42.

DREAMWORKS L.L.C., UNIVERSAL CITY, CA:
2,911,446. CANC. INT. CL. 28.

DRESSER, INC., ADDISON, TX, MASONELAN INTERNATIONAL, INC., NORWOOD, MA:
925,372. REN. 7-16-11. U.S. CL. 13 (INT. CL. 6).

DREW KAPLAN AGENCY, INC., TARZANA, CA:
2,514,905. REN. 7-15-11. INT. CL. 35.
2,514,942. REN. 7-15-11. INT. CL. 35.

DRIVER'S WAY, INC., PELHAM, AL, DBA DRIVER'S WAY OF BIRMINGHAM, INC.:
2,490,595. REN. 7-15-11. INT. CL. 35.

DRS HEALTH GROUP LLC, PARKER, CO:
4,015,612. PUB. 6-7-2011. INT. CL. 44.
4,015,617. PUB. 6-7-2011. INT. CL. 44.

DRUGSTORE.COM, INC., BELLEVUE, WA:
2,909,368. CANC. INT. CL. 35.

DRYPLEX INC, TAMPA, FL:
4,015,524. PUB. 6-7-2011. INT. CL. 25.

DS WATERS OF AMERICA, INC., ATLANTA, GA:
4,016,420. INT. CL. 32.

DSD SERVICES, INC., YOAKUM, TX:
2,911,655. CANC. INT. CL. 29.

DSM IP ASSETS B.V., NETHERLANDS:
4,014,637. PUB. 6-7-2011. INT. CL. 42.

DSM IP ASSETS B.V., HEERLEN, NETHERLANDS:
4,016,602. MULTIPLE CLASS, INT. CLS. 5 AND 30.

DTECTION INCORPORATED, SAN DIEGO, CA:
4,015,410. PUB. 6-7-2011. INT. CL. 45.

DTL, INC., PALM SPRINGS, CA:
2,911,369. CANC. INT. CL. 3.

DUAL EYEWEAR LLC, BOULDER, CO:
4,015,625. PUB. 6-7-2011. INT. CL. 9.

DUBOIS ENTERPRISES, INC., CEDAR HILL, TX:
2,702,677. CANC. INT. CL. 36.

DUECO, INC., WAUKESHA, WI:
1,658,723. REN. 7-18-11. INT. CL. 37.

DUFF, ROBERT ALEXANDER, LASALLE, ONTARIO, CANADA:
4,014,865. PUB. 6-7-2011. INT. CL. 41.

DUGAN, CASEY, EDINA, MN:
2,911,039. CANC. INT. CL. 41.

DUNCAN ENTERPRISES, FRESNO, CA:
2,458,179. REN. 7-18-11. INT. CL. 2.

DUNKINS, JAMES, OMAHA, NE:
1,649,013. REN. 7-16-11. INT. CL. 36.

DUNLOP SLAZENGER GROUP LIMITED, BURNHAM, BUCKINGHAMSHIRE SL1 8DF, UNITED KINGDOM:
2,413,154. CANC. INT. CL. 28.

DURABLE ORTHOPAEDIC SUPPLIES, LLC, EL PASO, TX:
4,015,532. PUB. 6-7-2011. INT. CL. 10.

DURFERRIT GMBH, MANNHEIM, FED REP GERMANY:
1,174,680. REN. 7-16-11. INT. CL. 1.

DUROMAR, INC., PEMBROKE, MA, MARTEK, INC., HINGHAM, MA:
1,184,784. REN. 7-20-11. INT. CL. 19.

DYKSTRA, TRACI, FORT WORTH, TX, DBA INDUSTRIAL PACKAGE:
4,016,039. PUB. 6-7-2011. INT. CL. 14.

DYNAMIC COOKING SYSTEMS, INC., HUNTINGTON BEACH, CA:
2,470,241. REN. 7-19-11. INT. CL. 11.

DYNAMIC FRAMES, INC., TORRANCE, CA:
2,534,407. REN. 7-21-11. INT. CL. 20.

DYNASTY CONSOLIDATED INDUSTRIES, INC., DALLAS, TX:
2,588,645. REN. 7-21-11. INT. CL. 20.
2,588,646. REN. 7-21-11. INT. CL. 20.

DYNAVOX SYSTEMS LLC, PITTSBURGH, PA:
2,910,863. CANC. INT. CL. 9.

DYNO NOBEL INC., SALT LAKE CITY, UT:
4,014,969. PUB. 6-7-2011. INT. CL. 9.

DYSON CORPORATION, THE, PAINESVILLE, OH:
2,909,501. CANC. INT. CL. 6.

E & E HOLDINGS GROUP LLC, NEW YORK, NY:
4,017,227. INT. CL. 43.

E & M CHARM CORP., DEERFIELD BEACH, FL:
4,015,220. PUB. 6-7-2011. INT. CL. 43.
4,015,221. PUB. 6-7-2011. INT. CL. 43.

- E. I. DU PONT DE NEMOURS AND COMPANY, WILMINGTON, DE:
4,016,031, PUB. 6-7-2011. INT. CL. 16.
- E. I. DU PONT DE NEMOURS AND COMPANY, WILMINGTON, DE:
4,016,304, INT. CL. 5.
4,016,305, INT. CL. 5.
- E.G. EMIL & SONS, INC., PHILADELPHIA, PA:
2,465,915. REN. 7-15-11. INT. CL. 29.
- EAGLE FIRE INC., RICHMOND, VA:
2,566,489. REN. 7-20-11. MULTIPLE CLASS, INT. CLS. 37 AND 42.
- EAGLE HOME PRODUCTS, INC., HUNTINGTON, NY:
4,017,341, INT. CL. 21.
4,017,347, INT. CL. 21.
- EAGLE PUBLISHING, INC., WASHINGTON, DC:
4,017,393, INT. CL. 41.
- EARTH NETWORKS, INC., GERMANTOWN, MD:
4,016,177, MULTIPLE CLASS, INT. CLS. 38 AND 42.
- EARTH SALTS INTERNATIONAL, INC., SAN ANTONIO, TX:
2,909,764, CANC. INT. CL. 3.
- EARTHLINK, INC., ATLANTA, GA:
2,493,252. REN. 7-15-11. INT. CL. 35.
- EARTHLY BODY, INC., CHATSWORTH, CA:
4,015,117, PUB. 6-7-2011. INT. CL. 3.
- EASEBON SERVICES LIMITED, KWUN TONG, HONG KONG:
4,017,268, INT. CL. 28.
- EASI-SET INDUSTRIES, MIDLAND, VA:
2,587,198. REN. 7-18-11. INT. CL. 19.
- EASYFINE ASIA, LTD., PHILADELPHIA, PA:
4,017,335, INT. CL. 25.
- EASYGROUP IP LICENSING LIMITED, CAMDEN, LONDON, ENGLAND:
2,909,566, CANC. MULTIPLE CLASS, INT. CLS. 16, 39, 42 AND 43.
- EAZYPower CORPORATION, CHICAGO, IL:
4,014,322, PUB. 6-7-2011. MULTIPLE CLASS, INT. CLS. 7 AND 8.
- EBSco INDUSTRIES, INC., BIRMINGHAM, AL:
4,015,576, PUB. 6-7-2011. INT. CL. 41.
- ECCO SKO A/S, DENMARK:
4,014,605, PUB. 6-7-2011. INT. CL. 25.
- ECKE GERANIUMS, LLC, ENCINITAS, CA:
1,160,201. REN. 7-18-11. INT. CL. 31.
- ECKERD CORPORATION, LARGO, FL:
2,909,674, CANC. INT. CL. 35.
- ECKLER INDUSTRIES, INC., TITUSVILLE, FL, ECKLER INDUSTRIES INC., TITUSVILLE, FL:
1,660,186. REN. 7-21-11. INT. CL. 42.
- ECLINICALWORKS, LLC, WESTBOROUGH, MA:
4,014,335, PUB. 6-7-2011. INT. CL. 9.
- ECO NATURFORSCHUNGS-UND TECHNOLOGIE GESELLSCHAFT MBH, HEUHLHEIM, FED REP GERMANY:
2,909,424, CANC. MULTIPLE CLASS, INT. CLS. 11 AND 32.
- ECOLAB INC., ST. PAUL, MN:
1,975,355, CANC. INT. CL. 20.
- ECOLAB USA INC., SAINT PAUL, MN:
4,014,916, PUB. 5-3-2011. INT. CL. 35.
4,014,917, PUB. 5-3-2011. INT. CL. 40.
- ECOMMERCE INDUSTRIES, INC., LEESBURG, VA:
4,016,909, INT. CL. 42.
- ECONOMOS USA, INC., CLEVELAND, OH:
2,909,874, CANC. INT. CL. 17.
- ECOOOLTHING CORP., IRVINE, CA:
2,473,920. REN. 7-18-11. MULTIPLE CLASS, INT. CLS. 16, 20 AND 28.
- ECOOUTFITTERS.NET, LLC C/O RAINA RUSSO, ATLANTIC BEACH, NY:
4,016,623, INT. CL. 35.
- ECORAD INC., ST-JEAN-PORT-JOLI (QC), CANADA:
4,014,333, PUB. 6-7-2011. MULTIPLE CLASS, INT. CLS. 11, 37 AND 42.
- EDBRO PLC, BOLTON, UNITED KINGDOM:
4,014,866, PUB. 6-7-2011. MULTIPLE CLASS, INT. CLS. 7 AND 12.
- EDDIE BAUER LICENSING SERVICES LLC, BELLEVUE, WA:
2,469,401. REN. 7-17-11. MULTIPLE CLASS, INT. CLS. 3, 4 AND 11.
- EDDIE'S WAREHOUSE OUTLET LLC, CARTERET, NJ, DBA EDDIE'S OUTLET:
2,911,072, CANC. INT. CL. 35.
- EDDY, MICHAEL, ORMOND BEACH, FL:
4,016,203, INT. CL. 25.
- EDI HEALTH GROUP, INC., IRVINE, CA, DBA DENTALX-CHANGE:
4,014,923, PUB. 6-7-2011. INT. CL. 36.
- EDITORIAL SUDAMERICANA SOCIEDAD ANONIMA, 1103 BUENOS AIRES, ARGENTINA:
2,462,976. REN. 7-18-11. INT. CL. 16.
- EDLAB GROUP FOUNDATION, LYNNWOOD, WA, DBA EDLAB GROUP:
4,015,441, PUB. 6-7-2011. INT. CL. 35.
- EDUCATION EXPERIENCES INC., TORRANCE, CA:
2,303,767, CANC. INT. CL. 25.
- EDUCATIONAL FINANCE INSTITUTE, INC., NATICK, MA:
2,910,317, CANC. INT. CL. 9.
- EDUCATIONAL RECORDS BUREAU, NEW YORK, NY:
4,016,053, PUB. 6-7-2011. MULTIPLE CLASS, INT. CLS. 16 AND 41.
- EDUCATIONAL TESTING SERVICE, PRINCETON, NJ, AKA ETS:
4,016,355, INT. CL. 41.
- EDWARDS, RICHARD TOD, LA CROSSE, WI:
2,412,664, CANC. INT. CL. 42.
- EDWARDS, SCOTT, HONG KONG, CHINA:
4,016,365, INT. CL. 6.
- EDWIN PIERCE, LAS VEGAS, NV:
3,976,158, COR. INT. CL. 42.
- EFIRE GROUP, LLC, SACRAMENTO, CA:
4,016,984, INT. CL. 43.
- EGAN, CHARLES H., COPAN, OK, DBA 4-E CONSTRUCTION:
4,015,193, PUB. 6-7-2011. INT. CL. 37.
- EGOSCUE, INC., SAN DIEGO, CA:
2,910,245, CANC. INT. CL. 41.
- EGS ELECTRICAL GROUP LLC, ROSEMONT, IL:
2,468,093. REN. 7-15-11. MULTIPLE CLASS, INT. CLS. 9 AND 11.
2,468,094. REN. 7-15-11. MULTIPLE CLASS, INT. CLS. 9 AND 11.
2,494,591. REN. 7-15-11. MULTIPLE CLASS, INT. CLS. 9 AND 11.
- EHP, INC., LANCASTER, PA:
2,412,561, CANC. INT. CL. 36.
- EK DESIGNS, INC., COHASSET, MA:
2,910,927, CANC. INT. CL. 14.
- EK SUCCESS LTD., CLIFTON, NJ:
4,017,179, INT. CL. 16.
- EL CHICO RESTAURANTS, INC., DALLAS, TX, EL CHICO CORPORATION, DALLAS, TX:
929,775. REN. 7-18-11. U.S. CL. 101 (INT. CL. 35).
- ELANTAS CAMATTINI S.P.A., 1-43030 COLLECCHIO (PR), ITALY:
1,181,713. REN. 7-15-11. INT. CL. 1.
- ELASTOGEN LLC, WASHINGTON, DC:
4,014,931, PUB. 6-7-2011. INT. CL. 1.
- ELAVON, INC., ATLANTA, GA:
4,014,766, PUB. 6-7-2011. INT. CL. 9.
- ELECTRICAL TRAINING CENTER, INC., LINDENHURST, NY:
2,412,464, CANC. INT. CL. 41.
- ELECTRO KINETIC TECHNOLOGIES, LLC, GERMANTOWN, WI:
4,015,614, PUB. 6-7-2011. INT. CL. 12.
- ELECTRO-MAGWAVE, INC., VALLEY VIEW, OH, AKA E/M WAVE, INC.:
4,015,114, PUB. 6-7-2011. INT. CL. 9.
- ELECTROHIFI, LLC, SEATTLE, WA:
2,910,923, CANC. INT. CL. 9.

ELECTROMEDIA, LLC., WOODLAND HILLS, CA, AKA ELECTROMEDIA:
2,911,283, CANC. INT. CL. 41.

ELECTRONIC ARTS INC., REDWOOD CITY, CA:
2,909,839, CANC. INT. CL. 9.

ELECTRONIC DATA SYSTEMS CORPORATION, PLANO, TX:
2,911,063, CANC. MULTIPLE CLASS, INT. CLS. 35 AND 42.

ELECTRONIC EVOLUTIONS, INC., CARMEL, IN:
2,909,780, CANC. MULTIPLE CLASS, INT. CLS. 35, 37 AND 42.
2,909,781, CANC. MULTIPLE CLASS, INT. CLS. 35, 37 AND 42.

ELEMENT POWER HOLDINGS LP, EDINBURGH EH3 9WJ, UNITED KINGDOM:
4,014,328, PUB. 6-7-2011. INT. CL. 40.

ELEMENT SIX, COUNTY CLARE, IRELAND:
4,014,429, PUB. 6-9-2009. MULTIPLE CLASS, INT. CLS. 3, 7, 9 AND 10.
4,014,432, PUB. 6-30-2009. MULTIPLE CLASS, INT. CLS. 3, 7, 9 AND 10.

ELGIN SWEEPER COMPANY, ELGIN, IL, NORTHSIDE INDUSTRIES INC., CALGARY, ALBERTA, CANADA:
2,472,176. REN. 7-18-11. INT. CL. 12.

ELHALWANI, WAEL, ANAHEIM, CA:
4,016,854, INT. CL. 32.

ELIZABETH ARDEN, INC., MIAMI LAKES, FL:
2,909,350, CANC. MULTIPLE CLASS, INT. CLS. 14 AND 21.

ELLA'S KITCHEN (IP) LIMITED, LONDON, UNITED KINGDOM:
4,014,812, PUB. 6-7-2011. MULTIPLE CLASS, INT. CLS. 5, 29, 30 AND 32.

ELLIE PHOTOGRAPHY, INC. NEW YORK, NY:
4,015,530, PUB. 6-7-2011. INT. CL. 41.

ELLIOT ZIMMERMAN, P.A., PLANTATION, FL:
4,015,462, PUB. 6-7-2011. INT. CL. 9.

ELLIS, DANNY, POCAHONTAS, AR:
4,015,670, PUB. 6-7-2011. INT. CL. 42.

ELLIS' FINE WINES, JONESBORO, GA:
4,014,734, PUB. 6-7-2011. INT. CL. 33.

ELLUMEN, INC., ARLINGTON, VA:
3,988,255, COR. INT. CL. 42.

ELMER'S PRODUCTS, INC., WESTERVILLE, OH:
4,017,206, INT. CL. 16.

ELMOS SEMICONDUCTOR AKTIENGESELLSCHAFT, D-44227 DORTMUND, FED REP GERMANY:
2,471,025. REN. 7-15-11. INT. CL. 9.

ELYSIUM CAPITAL GROUP, L.P., STAMFORD, CT:
2,911,452, CANC. INT. CL. 36.
2,911,453, CANC. INT. CL. 36.

EMBLEM ENTERPRISES, INC., CHATSWORTH, CA:
4,016,277, MULTIPLE CLASS, INT. CLS. 6 AND 13.

EMBRACED ATLANTA, INC., ATLANTA, GA:
4,015,201, PUB. 6-7-2011. INT. CL. 44.

EMERSON COLLEGE, BOSTON, MA:
4,014,687, PUB. 6-7-2011. INT. CL. 41.
4,014,688, PUB. 6-7-2011. INT. CL. 41.
4,014,689, PUB. 6-7-2011. INT. CL. 41.

EMERSON ELECTRIC CO., ST. LOUIS, MO:
2,412,906, CANC. INT. CL. 7.
2,420,751. REN. 7-20-11. INT. CL. 7.

EMERY & ASSOCIATES OF ST. PETERSBURG, INC., CLEARWATER, FL:
4,015,142, PUB. 6-7-2011. INT. CL. 45.

EMIRATES INTEGRATED TELECOMMUNICATIONS COMPANY PJSC, DUBAI, UNITED ARAB EMIR.:
4,016,459, MULTIPLE CLASS, INT. CLS. 38 AND 45.

EMPOWERED CLOTHING COMPANY, LLC, PHOENIX, AZ:
4,015,251, PUB. 6-7-2011. INT. CL. 25.

EMS-PATENT AG, SWITZERLAND:
4,014,565, PUB. 6-7-2011. MULTIPLE CLASS, INT. CLS. 10, 14 AND 28.

EMSLAND-STÄRKE GMBH, FED REP GERMANY:
3,718,844, COR. MULTIPLE CLASS, INT. CLS. 1, 5 AND 30.

END GAMES ENTERTAINMENT, LLC, BROOMFIELD, CO:
4,017,191, INT. CL. 42.

ENDOVATIONS PTY LTD, AUSTRALIA:
4,014,574, PUB. 6-7-2011. INT. CL. 10.

ENDRESS+HAUSER PROCESS SOLUTIONS AG, SWITZERLAND:
4,014,451, PUB. 12-15-2009. INT. CL. 42.

ENDURAPACK, LLC, WESTBURY, NY:
4,017,151, INT. CL. 35.

ENERCISE GYM, LLC, WAYZATA, MN:
4,015,317, PUB. 6-7-2011. INT. CL. 41.

ENERGIE MEDIA GROUP, INC., CALABASAS, CA:
4,016,747, INT. CL. 16.

ENERGY EFFICIENCY SOLUTIONS, LLC, HOLLISTON, MA:
4,016,408, INT. CL. 7.

ENERGY INNOVATES MOTION, INC., PALM BEACH GARDENS, FL:
4,016,864, INT. CL. 25.

ENERSAVE US, SALT LAKE CITY, UT, DBA ENERSAVE INTELLIGENT SAVINGS:
4,017,177, INT. CL. 35.

ENEXITY, INC., AUSTIN, TX, DBA SECURELINK:
4,016,185, INT. CL. 9.

ENFORCE NUTRITION, LLC, SCHAUMBURG, IL:
4,015,309, PUB. 6-7-2011. INT. CL. 5.

ENGLAND, INC., NEW TAZEWELL, TN:
2,466,931. REN. 7-20-11. INT. CL. 20.

ENHANCED GLOBAL CONVERGENCE SYSTEMS, INC., NASHUA, NH:
2,910,574, CANC. INT. CL. 16.

ENODIS CORPORATION, NEW PORT RICHEY, FL:
4,016,720, MULTIPLE CLASS, INT. CLS. 11 AND 20.

ENSIGN GROUP INTERNATIONAL, PROVO, UT:
4,016,351, MULTIPLE CLASS, INT. CLS. 16 AND 18.

ENSOFTEK, INC., BEAVERTON, OR:
4,015,845, PUB. 6-7-2011. MULTIPLE CLASS, INT. CLS. 9 AND 42.
4,015,894, PUB. 6-7-2011. INT. CL. 42.

ENT AND ALLERGY ASSOCIATES, LLP, TARRYTOWN, NY:
4,014,967, PUB. 6-7-2011. INT. CL. 44.

ENTERAL HEALTH AND NUTRITION, LLC, CHESTERFIELD, MO:
4,016,946, INT. CL. 5.

ENTERAL HEALTH AND NUTRITION, LLC, CHESTERFIELD, MO, DBA ENTERAL CONFECTIONS:
4,016,947, INT. CL. 30.

ENTERCOM COMMUNICATIONS CORP., BALA CYNWYD, PA:
4,014,278, PUB. 6-7-2011. MULTIPLE CLASS, INT. CLS. 35, 38 AND 41.

ENVELOPE PRODUCT GROUP, LLC, STAMFORD, CT:
1,174,173. REN. 7-20-11. INT. CL. 16.

ENVIRO-TECH OF AMERICA, INC, CAPE CORAL, FL:
4,015,909, PUB. 6-7-2011. INT. CL. 1.

ENVIROAIR, LLC, SALT LAKE CITY, UT:
2,909,936, CANC. INT. CL. 9.

ENVIRONMENTAL CHEMICAL SOLUTIONS INC., GIG HARBOR, WA:
2,578,320. REN. 7-18-11. INT. CL. 3.

ENVIRONMENTAL CONTAINER SYSTEMS, INC., GRANTS PASS, OR, DBA ECS COMPOSITES:
4,014,332, PUB. 6-7-2011. MULTIPLE CLASS, INT. CLS. 20, 21 AND 35.

ENVIRONMENTAL DESIGN GROUP LLC, LAS VEGAS, NV:
4,017,352, MULTIPLE CLASS, INT. CLS. 37 AND 42.

ENVIRONMENTAL SCIENCE SERVICES, INC., DENHAM SPRINGS, LA:
4,016,724, INT. CL. 42.

ENZA ZADEN USA, INC., SALINAS, CA:
2,468,888. REN. 7-19-11. INT. CL. 31.

ENZYME FORMULATIONS, INC., MADISON, WI:
2,473,031. REN. 7-19-11. INT. CL. 16.

EPIC PHARMA, LLC, LAURELTON, NY:
4,014,209, PUB. 6-7-2011. INT. CL. 5.

- EPICUREAN FOOD AND BEVERAGES, LLC, ATLANTA, GA, DBA EFB:
4,016,038, PUB. 6-7-2011. INT. CL. 32.
- EPKIDS USA CORP., CORAL GABLES, FL:
2,910,701, CANC. MULTIPLE CLASS, INT. CLS. 25 AND 35.
- EPKO INDUSTRIES, INC., ELK GROVE VILLAGE, IL:
4,016,885, INT. CL. 2.
- EPONA RIDGE, ASHEVILLE, NC:
4,015,446, PUB. 6-7-2011. INT. CL. 41.
- EQUIFUSE, SUNNYVALE, CA:
4,014,825, PUB. 6-7-2011. INT. CL. 3.
- EQUINOX HOLDING, INC., NEW YORK, NY:
2,911,363, CANC. INT. CL. 3.
- EQUISYS PLC, LONDON, UNITED KINGDOM, EQUISYS PLC, LONDON, UNITED KINGDOM:
2,472,627. REN. 7-21-11. INT. CL. 9.
- EQUITY SCHOLAR, LLC, NEW YORK, NY:
4,017,216, INT. CL. 36.
- EQUITYLABS, INC., PROVIDENCE, UT:
4,016,391, INT. CL. 5.
- ERACE, NEW ORLEANS, LA:
4,015,381, PUB. 6-7-2011. INT. CL. 41.
- ERHUNMWUNSE, GIBSON, ALEXANDRIA, VA:
4,016,870, MULTIPLE CLASS, INT. CLS. 44 AND 45.
- ERIC MANDEL, M.D., P.C., NEW YORK, NY:
2,911,029, CANC. INT. CL. 44.
- ERIE BREWING COMPANY, ERIE, PA:
2,385,693, CANC. INT. CL. 32.
- ERIE BRUSH & MANUFACTURING CORP., CHICAGO, IL:
2,412,026, CANC. INT. CL. 21.
- ERIE COUNTY MEDICAL CENTER CORPORATION, BUFFALO, NY:
4,015,849, PUB. 6-7-2011. INT. CL. 44.
- ERIKATY, LLC, AVENTURA, FL:
4,015,124, PUB. 6-7-2011. INT. CL. 35.
- ERIKSEN TRANSLATIONS INC., BROOKLYN, NY:
4,014,743, PUB. 6-7-2011. MULTIPLE CLASS, INT. CLS. 35 AND 41.
- ERMENEGILDO ZEGNA CORPORATION, ENGLEWOOD, NJ:
4,017,152, INT. CL. 35.
- ERNEST'S CAFE COMPANY, KEY WEST, FL:
2,909,579, CANC. MULTIPLE CLASS, INT. CLS. 35 AND 43.
- ERNIE BALL, INC., COACHELLA, CA:
4,016,194, INT. CL. 15.
- ES&S INNOVATIONS, LLC, OMAHA, NE:
4,016,092, PUB. 6-7-2011. INT. CL. 9.
- ESCADA LUXEMBOURG S.A.R.L., LUXEMBOURG:
3,294,189, AM. MULTIPLE CLASS, INT. CLS. 9, 14, 18 AND 25.
- ESCANTE, INC., SAN ANTONIO, TX:
4,015,439, PUB. 6-7-2011. INT. CL. 25.
4,017,062, INT. CL. 25.
4,017,063, INT. CL. 25.
- ESCOA INTERNATIONAL LIMITED, L'ESTORIL, AVENUE PRINCESS GRACE, MONACO:
2,909,510, CANC. INT. CL. 39.
- ESSDRAS M SUAREZ, WATERTOWN, MA, DBA VISYOGA:
4,016,367, INT. CL. 41.
- ESSEX TECHNOLOGY, INC., FORT WAYNE, IN, ESSEX GROUP, INC., FT. WAYNE, IN:
1,172,079. REN. 7-19-11. INT. CL. 9.
- ESSRIG, MICHAEL, DEL MAR, CA:
4,015,056, PUB. 6-7-2011. INT. CL. 12.
- ESTSOFT CORP., REPUBLIC OF KOREA:
4,014,666, PUB. 6-7-2011. MULTIPLE CLASS, INT. CLS. 9, 35 AND 42.
4,014,668, PUB. 6-7-2011. MULTIPLE CLASS, INT. CLS. 9, 35 AND 42.
- ETAB INTERNATIONAL, INC., ST. LOUIS, MO:
2,911,382, CANC. INT. CL. 42.
- ETCHEGARAY FARMS, LLC, VISALIA, CA:
4,016,683, MULTIPLE CLASS, INT. CLS. 29 AND 32.
4,016,690, MULTIPLE CLASS, INT. CLS. 29 AND 32.
- ETFCU SERVICE ORGANIZATION, LLC, EVANSVILLE, IN:
2,555,483. REN. 7-20-11. MULTIPLE CLASS, INT. CLS. 39 AND 42.
- ETHERIOS, DALLAS, TX:
4,015,357, PUB. 6-7-2011. INT. CL. 42.
- ETHNIQ INC., FONTANA, CA:
4,014,941, PUB. 6-7-2011. INT. CL. 25.
- ETHRIDGE, ROGER K., ROWLETT, TX:
2,910,417, CANC. INT. CL. 41.
- ETIQUETTE AND LEADERSHIP INSTITUTE, LLC, WATKINSVILLE, GA:
4,015,145, PUB. 6-7-2011. INT. CL. 41.
- EU YAN SANG INTERNATIONAL LTD, 058818, SINGAPORE:
2,910,369, CANC. INT. CL. 3.
- EUCLID MIDDLE SCHOOL, LITTLETON, CO:
4,015,830, PUB. 6-7-2011. INT. CL. 41.
- EUREKA! INSTITUTE, INC., NEWTOWN, OH:
2,469,817. REN. 7-18-11. INT. CL. 41.
- EURICKA LOWE ALUGAS, NEW ORLEANS, LA:
2,910,372, CANC. INT. CL. 41.
- EURO-PRO OPERATING LLC, NEWTON, MA:
4,016,120, PUB. 6-7-2011. INT. CL. 7.
- EUROGAS CORPORATION, CALGARY, ALBERTA, CANADA:
3,902,533, CANC. INT. CL. 42.
- EUROPEAN ASSOCIATION OF INVESTORS IN NON LISTED REAL ESTATE VEHICLES (INREV), AMSTERDAM, NETHERLANDS:
4,014,710, PUB. 6-7-2011. MULTIPLE CLASS, INT. CLS. 9, 16, 35, 36 AND 41.
4,014,711, PUB. 6-7-2011. MULTIPLE CLASS, INT. CLS. 9, 16, 35, 36 AND 41.
- EUROPOL IMPORT, INC., BENSENVILLE, IL:
2,910,613, CANC. INT. CL. 29.
- EVAN ARMIN WALTER, OKLAHOMA CITY, OK AND PATRICIA GABERINO CAREY, OKLAHOMA CITY, OK AND BRIAN DOUGLAS MITCHELL, OKLAHOMA CITY, OK:
4,015,545, PUB. 6-7-2011. INT. CL. 36.
- EVAN BRODY, AVENTURA, FL:
4,015,002, PUB. 6-7-2011. MULTIPLE CLASS, INT. CLS. 35 AND 42.
- EVENT WHOLESALE SUPPLIES, INC., SYLMAR, CA:
4,017,409, INT. CL. 35.
- EVEREADY BATTERY COMPANY, INC., ST. LOUIS, MO:
2,911,731, CANC. INT. CL. 3.
2,911,824, CANC. INT. CL. 9.
- EVERGLADES DIRECT, INC., NORTH MANKATO, MN:
2,590,063. REN. 7-19-11. INT. CL. 16.
2,590,063, CANC. INT. CL. 9.
- EVERGREEN AUTOMOTIVE PERFORMANCE INDUSTRIES, INC., PHOENIX, AZ:
4,015,199, PUB. 6-7-2011. INT. CL. 12.
- EVIL MOON SPIRITS LLC, SCOTTSDALE, AZ:
4,015,302, PUB. 6-7-2011. INT. CL. 33.
- EVO, INC., YOUNTVILLE, CA:
4,015,987, PUB. 6-7-2011. INT. CL. 16.
- EVRIHOLDER PRODUCTS, LLC, ANAHEIM, CA:
4,017,126, INT. CL. 21.
- EWILLOW.COM, LLC, JUPITER, FL:
4,016,308, INT. CL. 41.
- EX LIBRIS LTD., JERUSALEM, ISRAEL:
4,014,290, PUB. 6-7-2011. MULTIPLE CLASS, INT. CLS. 9 AND 42.
- EXCELLENCE BOYS CHARTER SCHOOL, BROOKLYN, NY:
4,015,321, PUB. 6-7-2011. INT. CL. 41.
- EXECUTECH LEASE GROUP, VANCOUVER, WA:
4,015,172, PUB. 6-7-2011. INT. CL. 35.
- EXLSERVICE HOLDINGS, INC., NEW YORK, NY:
4,016,669, MULTIPLE CLASS, INT. CLS. 35, 36, 39 AND 45.
- EXPANSION MANAGEMENT GROUP, LLC, TAMPA, FL:
4,014,910, PUB. 6-7-2011. MULTIPLE CLASS, INT. CLS. 35 AND 36.
- EXPERIMENTAL AIRCRAFT ASSOCIATION, INC., OSHKOSH, WI:
2,457,244. REN. 7-15-11. MULTIPLE CLASS, INT. CLS. 16, 25 AND 41.

EXPONENTIAL EDGE, INC., PALO ALTO, CA:
 4,015,907, PUB. 6-7-2011. INT. CL. 35.
 EXPOVISION, INC., FALLS CHURCH, VA:
 2,573,215. REN. 7-19-11. INT. CL. 35.
 2,573,216. REN. 7-18-11. INT. CL. 35.
 EXPRESS MESSENGER SYSTEMS, INC., PHOENIX, AZ:
 2,591,082. REN. 7-19-11. INT. CL. 39.
 EXPRESS, LLC, COLUMBUS, OH:
 4,016,278, INT. CL. 35.
 EXPRO TECHNOLOGIES INC., SAINT-TIMOTHEE, QUE-
 BEC, CANADA:
 2,910,376, CANC. INT. CL. 13.
 EXSILENT BV, AMSTERDAM, NETHERLANDS:
 4,017,299, INT. CL. 10.
 EYE-CETERA CORP., CHICAGO, IL:
 2,468,385. REN. 7-18-11. INT. CL. 35.
 EZ PREPAID LLC, BALTIMORE, MD, DBA EZ PREPAID
 LLC:
 4,017,391, INT. CL. 36.
 EZ STREET, LLC, CARY, IN:
 4,015,748, PUB. 6-7-2011. MULTIPLE CLASS, INT. CLS. 35
 AND 37.
 EZ-FLO INTERNATIONAL, INC., GREENVILLE, TX, DBA
 PLUMBERS ACCESS:
 2,909,673, CANC. MULTIPLE CLASS, INT. CLS. 2, 6, 8, 9,
 11, 17 AND 21.
 F.F.C. CREATIVE GROUP S.R.L., ITALY:
 4,014,584, PUB. 6-7-2011. MULTIPLE CLASS, INT. CLS.
 14, 18 AND 25.
 F.W. OVENTROP GMBH & CO.KG, OLSBERG, FED REP
 GERMANY:
 4,014,329, PUB. 6-1-2010. INT. CL. 11.
 FAB METAL SERVICES, LLC, EDGEWATER, FL:
 2,911,159, CANC. INT. CL. 12.
 2,911,160, CANC. INT. CL. 25.
 FABBELLA, CHARLES, BROOKLYN, NY:
 4,017,399, INT. CL. 36.
 FACET TECHNOLOGIES, LLC, KENNESAW, GA:
 2,911,590, CANC. MULTIPLE CLASS, INT. CLS. 35, 39, 40
 AND 42.
 FAIRCHILD, BOBBI G, CHARLOTTE, NC, AKA BOBBI G
 DBA BY DESIGN CONCEPTS, INC.:
 2,911,606, CANC. INT. CL. 16.
 FAIRFIELD LINE, INC., THE, FAIRFIELD, IA:
 1,661,782. REN. 7-19-11. INT. CL. 25.
 FAIRFIELD STONE & LANDSCAPE SUPPLY, LLC, FAIR-
 FIELD, CT:
 4,016,315, INT. CL. 19.
 FAIRWAY GROUP AQUISITION COMPANY, NEW YORK,
 NY:
 4,017,406, INT. CL. 35.
 FALEY ENTERPRISES, INC., DUBUQUE, IA:
 2,713,139, CANC. INT. CL. 7.
 FALKEN ARTS PRODUCTIONS, THOUSAND OAKS, CA:
 4,015,253, PUB. 6-7-2011. INT. CL. 41.
 FALKSON INC., VALHALLA, NY:
 4,016,606, INT. CL. 35.
 FALICK, MARCELO ANDRES, HOUSTON, TX:
 4,016,192, INT. CL. 25.
 FAMILY HERITAGE LIFE INSURANCE COMPANY OF
 AMERICA, BROADVIEW HEIGHTS, OH:
 2,466,684. REN. 7-16-11. INT. CL. 36.
 FAMILYLIFE REALTY SERVICES, INC., COSTA MESA, CA:
 2,412,278, CANC. INT. CL. 36.
 2,412,279, CANC. INT. CL. 36.
 FAMILYTREMEDIA, HIGHLANDS RANCH, CO:
 2,910,720, CANC. INT. CL. 9.
 FAN FI INTERNATIONAL, INC., SPARKS, NV:
 4,016,165, INT. CL. 11.
 FAN, ASHLEY, LOS ANGELES, CA:
 4,015,956, PUB. 6-7-2011. INT. CL. 35.
 FANTASYONICE LIMITED, IRELAND:
 4,014,591, PUB. 6-7-2011. INT. CL. 35.
 FAR REACH TECHNOLOGIES, INCORPORATED, CEDAR
 FALLS, IA:
 4,015,627, PUB. 6-7-2011. INT. CL. 42.
 FARAGHER FAMILY FARM, LLC, NEWPORT, KY:
 2,910,054, CANC. INT. CL. 30.
 FARCA, DAVID, SCOTTSDALE, AZ:
 2,412,308, CANC. INT. CL. 20.
 2,412,309, CANC. INT. CL. 20.
 2,412,310, CANC. INT. CL. 20.
 FARM JOURNAL, INC., PHILADELPHIA, PA:
 4,014,919, PUB. 6-7-2011. INT. CL. 16.
 4,014,920, PUB. 6-7-2011. INT. CL. 44.
 FARMASEA HEALTH LLC, PHOENIX, AZ:
 4,014,789, PUB. 6-7-2011. INT. CL. 5.
 FARMERS GROUP, INC., LOS ANGELES, CA:
 4,016,753, MULTIPLE CLASS, INT. CLS. 9 AND 36.
 4,016,757, MULTIPLE CLASS, INT. CLS. 35 AND 36.
 FARNAM COMPANIES, INC., PHOENIX, AZ, MCCUL-
 LOUGH CARTWRIGHT PHARMACEUTICAL CORPORA-
 TION, BARRINGTON, IL:
 1,481,262. REN. 7-20-11. MULTIPLE CLASS, INT. CLS. 3
 AND 5.
 FARRIS, ROY, GILBERT, AZ, AKA THE LEGENDS OF
 ROCK AND WRESTLING:
 4,016,961, INT. CL. 41.
 FASCINATION GRAPHICS, INC., S. KENT, WA:
 2,411,901, CANC. INT. CL. 20.
 FASHIONED IN HIS IMAGE, TOTAL WOMEN'S CENTER,
 INC., NASHVILLE, TN:
 2,909,985, CANC. MULTIPLE CLASS, INT. CLS. 41 AND
 44.
 FAST DISTRIBUTING, INC., MOUNTAIN LAKE, MN:
 2,909,753, CANC. INT. CL. 7.
 FAT COP, LLC, AMITYVILLE, NY:
 4,016,021, PUB. 6-7-2011. INT. CL. 21.
 FAUCHER, BRIAN KEITH, EDMONDS, WA:
 2,911,238, CANC. INT. CL. 42.
 FAUGHEY, KATHRYN, NEW YORK, NY:
 2,413,152, CANC. INT. CL. 42.
 FAULKNER DESIGN GROUP, INC., DALLAS, TX:
 4,015,096, PUB. 6-7-2011. INT. CL. 42.
 FEAR NO FASHION, INC, LOS ANGELES, CA:
 4,016,481, INT. CL. 25.
 FEARLESS SOLUTIONS, LLC, BALTIMORE, MD:
 4,015,402, PUB. 6-7-2011. INT. CL. 42.
 FEDERAL MEDICAL, INC., BETHESDA, MD:
 2,911,023, CANC. INT. CL. 36.
 FEDERAL NATIONAL MORTGAGE ASSOCIATION, WA-
 SHINGTON, DC, DBA FANNIE MAE:
 2,910,483, CANC. INT. CL. 36.
 FEDERAL-MOGUL WORLD WIDE, INC., SOUTHFIELD,
 MI:
 2,473,480. REN. 7-15-11. INT. CL. 12.
 FEDERATED GROUP, INC., THE, ARLINGTON HEIGHTS,
 IL:
 2,469,436. REN. 7-19-11. MULTIPLE CLASS, INT. CLS. 3,
 6, 16, 21, 29, 30, 31 AND 32.
 FELD ENTERTAINMENT, INC., VIENNA, VA:
 4,015,430, PUB. 6-7-2011. INT. CL. 41.
 FELE HOLDING CORPORATION, MIRAMAR, FL:
 4,016,940, INT. CL. 41.
 FELLOWES, INC., ITASCA, IL:
 2,442,135. REN. 7-19-11. MULTIPLE CLASS, INT. CLS. 3,
 9, 16 AND 20.
 FEMMEGEMS, LLC, NEW YORK, NY:
 2,909,741, CANC. MULTIPLE CLASS, INT. CLS. 14 AND
 35.
 FEMNAV LLC, SCOTTSDALE, AZ:
 4,015,753, PUB. 6-7-2011. INT. CL. 9.
 FENGLIDA TRADING INC., LOS ANGELES, CA:
 4,015,892, PUB. 6-7-2011. INT. CL. 25.
 FENTEM, LAURA J., CHANTILLY, VA, DBA NEIGHBOR-
 HOOD HEALTH AND FITNESS "2" GO:
 4,016,812, INT. CL. 24.
 FERNANDO MIGLIASSI, MIAMI, FL:
 4,016,766, MULTIPLE CLASS, INT. CLS. 11 AND 25.
 FERNDALE IP, INC., FERNDALE, MI:
 4,015,579, PUB. 6-7-2011. INT. CL. 35.
 FERRO CORPORATION, CLEVELAND, OH, FERRO EN-
 AMEL CORPORATION, CLEVELAND, OH:
 545,912. REN. 7-19-11. U.S. CL. 1 (INT. CL. 1).
 FERTILITY SOLUTIONS, INC., CLEVELAND, OH:
 4,015,211, PUB. 6-7-2011. INT. CL. 10.

- FESTFARE, INC., LAS VEGAS, NV:
4,017,426, INT. CL. 44.
- FESTFARE, INC., LAS VEGAS, CA:
4,017,428, INT. CL. 35.
- FESTIVAL FUN PARKS, LLC, NEWPORT BEACH, CA:
4,015,313, PUB. 6-7-2011. INT. CL. 41.
- FGD, INC., BEVERLY HILLS, CA:
4,016,208, INT. CL. 25.
- FHF FUNKE + HUSTER FERNSIG GMBH, MUELHEIM AN DER RUHR, FED REP GERMANY:
4,016,463, MULTIPLE CLASS, INT. CLS. 9 AND 38.
- FIBERGLASS SOLUTIONS INTERNATIONAL MANUFACTURING, INC., FT. MYERS, FL:
1,991,384, CANC. INT. CL. 37.
- FIBERLINKS TEXTILES INC., POINTE-CLAIRE, CANADA:
4,016,288, INT. CL. 22.
- FIBRE-CRAFT MATERIALS CORPORATION, NILES, IL:
2,909,953, CANC. MULTIPLE CLASS, INT. CLS. 16, 20, 26 AND 28.
- FIELDBUS FOUNDATION, AUSTIN, TX:
2,975,086, AM. U.S. CL. A.
- FIGESBAL, 98800 NOUMEA, FRANCE:
2,910,486, CANC. INT. CL. 33.
- FILANTHROPISTS.COM, INC., OAKLAND, NJ:
4,017,349, INT. CL. 35.
- FINANCIAL DESTINATION, INC., DERRY, NH:
2,910,126, CANC. INT. CL. 38.
2,910,127, CANC. INT. CL. 41.
- FINANCIAL STANDARDS, INC., WASHINGTON, DC:
2,910,473, CANC. MULTIPLE CLASS, INT. CLS. 35 AND 41.
- FINEKIND FACTORY LLC, ISLAND LAKE, IL:
4,016,323, INT. CL. 16.
- FINGERHUT DIRECT MARKETING, INC., EDEN PRAIRIE, MN:
3,765,982, COR. INT. CL. 8.
- FIORENTINO, MARK, WINTER HAVEN, FL:
2,911,019, CANC. INT. CL. 42.
- FIRM SOLUTIONS, LLC, TAMPA, FL:
4,015,675, PUB. 6-7-2011. MULTIPLE CLASS, INT. CLS. 35, 41 AND 42.
- FIRST CITIZENS BANK, ELIZABETHTOWN, KY:
4,015,772, PUB. 6-7-2011. INT. CL. 36.
- FIRST HORIZON NATIONAL CORPORATION, MEMPHIS, TN:
2,413,257, CANC. INT. CL. 36.
4,015,224, PUB. 6-7-2011. MULTIPLE CLASS, INT. CLS. 35 AND 36.
- FIRST NATIONAL BANK OF OMAHA, OMAHA, NE:
2,470,337, REN. 7-19-11. INT. CL. 36.
- FIRST PIONEER HOLDING, INC., DENVER, CO:
2,911,455, CANC. INT. CL. 36.
- FIRST SERVICE NETWORKS, INC., LINTHICUM, MD:
4,016,777, INT. CL. 35.
4,016,778, INT. CL. 35.
- FIRST STATE BANK, FRANKSTON, TX:
2,909,885, CANC. INT. CL. 36.
- FIRST VICTORIA NATIONAL BANK, VICTORIA, TX:
4,015,043, PUB. 6-7-2011. INT. CL. 36.
- FISHER, THOMAS, ANAHEIM, CA:
4,015,669, PUB. 6-7-2011. INT. CL. 30.
- FISHMAN CORPORATION, HOPKINTON, MA:
4,014,393, PUB. 6-7-2011. INT. CL. 9.
- FITCREW INDUSTRIAL CORP., TAIPING, TAIWAN:
4,016,786, INT. CL. 35.
- FITNESS CLUB WAREHOUSE INC., LOS ANGELES, CA:
4,015,762, PUB. 6-7-2011. INT. CL. 35.
- FITZGERALD, DEBORAH A., GULF BREEZE, FL:
4,015,743, PUB. 6-7-2011. MULTIPLE CLASS, INT. CLS. 41 AND 42.
- FITZPATRICK, ANN T., KISSIMMEE, FL, DBA DREAMAGIC LLC:
4,015,133, PUB. 6-7-2011. INT. CL. 20.
- FITZPATRICK, MICHAEL JOSEPH, PALO ALTO, CA:
4,015,901, PUB. 6-7-2011. INT. CL. 3.
- FIVE BAMBOO LLC, SEATTLE, WA:
4,014,858, PUB. 6-7-2011. INT. CL. 25.
- FL FOOD LION, INC., SALISBURY, NC:
2,909,865, CANC. INT. CL. 35.
- FLANNERY, CHRISTINE, CINCINNATI, OH:
4,015,283, PUB. 6-7-2011. INT. CL. 44.
- FLARECASTER, L.C., AMES, IA:
4,015,178, PUB. 6-7-2011. INT. CL. 9.
- FLATHEAD LAKE CHERRY GROWERS, INC., BIGFORK, MT:
4,015,376, PUB. 6-7-2011. INT. CL. 35.
- FLAVORCRAFT, LLC, LOUISVILLE, KY:
4,014,921, PUB. 6-7-2011. INT. CL. 30.
- FLECKY, DAN E. ; VILLALBA, GASTON, HUNTINGTON BEACH CA., CA, DBA MALU:
4,016,469, INT. CL. 9.
- FLEET WHOLESALE SUPPLY CO., INC., APPLETON, WI:
2,508,954, REN. 7-19-11. INT. CL. 35.
4,015,022, PUB. 6-7-2011. INT. CL. 6.
- FLEMING, CRISTIAN R, BROOKLYN, NY, DBA THE PUBLIC SOCIETY:
4,015,395, PUB. 6-7-2011. INT. CL. 35.
- FLEXCO CORPORATION, FOSTORIA, OH:
2,412,966, CANC. INT. CL. 19.
- FLEXPATHS, LLC, HILLSDALE, NJ:
4,017,273, INT. CL. 35.
- FLIGHTSURANCE GMBH, FRANKFURT AM MAIN, FED REP GERMANY:
4,015,079, PUB. 6-7-2011. MULTIPLE CLASS, INT. CLS. 35 AND 36.
- FLIP FLOP TRUNK SHOW, LLC, PIERMONT, NY:
2,909,774, CANC. INT. CL. 35.
- FLIR SYSTEMS, INC., WILSONVILLE, OR:
2,911,470, CANC. INT. CL. 9.
- FLOAT PRO LLC, SHOREVIEW, MN:
4,016,811, INT. CL. 21.
- FLOCABULARY, LLC, BROOKLYN, NY:
4,015,081, PUB. 6-7-2011. MULTIPLE CLASS, INT. CLS. 9 AND 16.
- FLOOREXPO, INC., MARIETTA, GA:
2,458,163, REN. 7-15-11. INT. CL. 27.
- FLORA DANICA S.A.I.C., PCIA. DE BUENOS AIRES, ARGENTINA:
2,909,378, CANC. INT. CL. 29.
- FLORENCE FASHIONS (JERSEY) LIMITED, ST. HELIER, JERSEY, CHANNEL ISLANDS:
2,130,804, CANC. INT. CL. 18.
- FLORIDA HOME-IMPROVEMENT ASSOCIATES, INC., HOLLYWOOD, FL:
4,016,453, INT. CL. 19.
- FLORIDA YOUTH LACROSSE FOUNDATION, INC., BOCA RATON, FL:
4,015,387, PUB. 6-7-2011. INT. CL. 36.
- FLORIDAYS RESORT MANAGEMENT CO., LLC, ORLANDO, FL:
4,015,179, PUB. 6-7-2011. MULTIPLE CLASS, INT. CLS. 35, 36 AND 37.
4,015,180, PUB. 6-7-2011. MULTIPLE CLASS, INT. CLS. 35, 36 AND 37.
- FLORIDIAN LIQUID ASSETS, LLC, ORLANDO, FL:
4,015,194, PUB. 6-7-2011. INT. CL. 33.
- FLOWERS, INC., BOGART, GA:
4,016,717, MULTIPLE CLASS, INT. CLS. 16, 20, 21, 28 AND 35.
- FLOWERS, SAKHSHAT, WILLIAM, MAPLEWOOD, NJ, AKA FLOWERS HEALING ARTS & CKG:
4,016,594, INT. CL. 44.
- FLOWERSPOT.COM LLC, DELRAY BEACH, FL:
4,014,207, PUB. 6-7-2011. INT. CL. 35.
- FLOWQUEST, INC., KIRKLAND, WA:
2,911,247, CANC. INT. CL. 45.
- FLUENT, JEFFERY, MODESTO, CA:
4,016,472, INT. CL. 25.
- FLUID OPERATIONS GMBH, WALLDORF, FED REP GERMANY:
4,017,278, INT. CL. 9.
- FLUKE CORPORATION, EVERETT, WA:
2,504,696, REN. 7-16-11. INT. CL. 9.

FMC CORPORATION, PHILADELPHIA, PA:
4,017,034, INT. CL. 5.
4,017,083, INT. CL. 5.

FMR LLC, BOSTON, MA:
2,413,297, CANC. INT. CL. 36.
2,461,584, REN. 7-18-11. INT. CL. 36.

FNG AMAZING, LLC, JOHNSTON, IA:
4,016,488, INT. CL. 28.

FOARD, NEAL, WAYNE, NJ:
4,016,633, INT. CL. 41.

FOGARTY, HEATHER, LOS ANGELES, CA:
4,015,932, PUB. 6-7-2011. INT. CL. 41.

FOLDCRAFT CO., KENYON, MN:
1,687,153, REN. 7-15-11. INT. CL. 20.
1,689,073, REN. 7-15-11. INT. CL. 20.
1,689,076, REN. 7-15-11. INT. CL. 20.

FOLKS, INC., NORCROSS, GA:
2,911,533, CANC. INT. CL. 43.

FOMIN, ARKADY, DALLAS, TX:
2,910,359, CANC. INT. CL. 41.

FOMO PRODUCTS, INC., NORTON, OH:
4,015,657, PUB. 6-7-2011. INT. CL. 41.

FONECA INC, WILMINGTON, DE:
2,911,191, CANC. INT. CL. 38.

FONG, PETER SUI LUN, MONTEREY PARK, CA:
2,911,340, CANC. INT. CL. 28.

FONTSELF SA, SWITZERLAND:
4,014,494, PUB. 6-7-2011. MULTIPLE CLASS, INT. CLS. 9,
35, 41 AND 42.

FONVILLE MORISEY REALTY, INC., RALEIGH, NC:
4,016,927, INT. CL. 36.

FOOT IN MOTION, INC., SANTA MONICA, CA:
4,015,139, PUB. 6-7-2011. MULTIPLE CLASS, INT. CLS. 10
AND 44.

FOOTHOLDE, MINNEAPOLIS, MN:
4,015,383, PUB. 6-7-2011. INT. CL. 41.

FOR PLAY UNLIMITED, INC., CEDAR GROVE, NJ:
2,910,052, CANC. INT. CL. 35.

FORBO ADHESIVES, LLC., DURHAM, NC:
2,910,909, CANC. INT. CL. 1.

FORCE10 NETWORKS, INC., SAN JOSE, CA:
2,910,301, CANC. INT. CL. 9.

FORE GOLF DIVAS, INC., MONTEREY PARK, CA:
4,015,285, PUB. 6-7-2011. MULTIPLE CLASS, INT. CLS.
18, 25 AND 28.

FOREVER 21, INC., LOS ANGELES, CA:
2,583,457, REN. 7-16-11. INT. CL. 25.

FORTE MANAGEMENT SYSTEMS GROUP CORPORA-
TION, MONMOUTH JUNCTION, NJ, DBA SAVER'S CLUB
LIQUOR LOCKER AND SAVER'S CLUB WINE LOCKER:
4,015,349, PUB. 6-7-2011. INT. CL. 33.

FOSHAN CITY NANHAI YONGFENG ALUMINIUM CO.,
LTD., GUANGDONG PROVINCE, CHINA:
4,014,607, PUB. 6-7-2011. INT. CL. 6.

FOSHAN SHUNDE TALENT INDUSTRIAL CO., LTD.,
CHINA:
4,014,629, PUB. 6-7-2011. MULTIPLE CLASS, INT. CLS. 7,
9 AND 11.

FOSTER-MILLER, INC., WALTHAM, MA:
2,909,977, CANC. INT. CL. 3.

FOTONA PROIZVODNJA OPTOELEKTRONSKIH NAPRAV
D.D., SI-1000 LJUBLJANA, SLOVENIA:
4,014,489, PUB. 6-7-2011. MULTIPLE CLASS, INT. CLS.
16, 35, 41, 42 AND 44.

FOUNTANA GMBH & CO. KG, FED REP GERMANY:
4,014,556, PUB. 6-7-2011. INT. CL. 21.

FOURSTICKS PTY LTD, SOUTH AUSTRALIA, AUSTRALIA:
2,909,436, CANC. MULTIPLE CLASS, INT. CLS. 9, 38
AND 42.

FOX FACTORY, INC., WATSONVILLE, CA:
4,017,255, INT. CL. 16.
4,017,256, INT. CL. 35.

FOX NEWS NETWORK, LLC, NEW YORK, NY:
4,014,697, PUB. 6-7-2011. INT. CL. 41.
4,014,698, PUB. 6-7-2011. INT. CL. 41.

FRAMAR S.P.A., ITALY:
2,976,306.

FRANC ARNOLD, 56068 KOBLENZ, FED REP GERMANY:
4,014,586, PUB. 6-7-2011. INT. CL. 12.

FRANK L. STILE M.D., PC, LAS VEGAS, NV:
4,016,293, MULTIPLE CLASS, INT. CLS. 3 AND 44.

FRASER, STANFORD L, CHARLOTTE, NC:
4,016,266, INT. CL. 25.

FRATERNITE NOTRE DAME, INC., CHICAGO, IL:
4,014,723, PUB. 6-7-2011. INT. CL. 45.

FRAUNHOFER-GESELLSCHAFT ZUR; FÖRDERUNG DER
ANGEWANDTEN FORSCHUNG E.V., FED REP GER-
MANY:
3,639,768, COR. MULTIPLE CLASS, INT. CLS. 9, 38, 41
AND 42.

FRAZILLA LLC, DALLAS, TX:
4,017,068, INT. CL. 35.

FRED DEELEY IMPORTS LTD., CONCORD, ONTARIO,
CANADA:
2,910,433, CANC. INT. CL. 41.

FREEDOM CANDY, INC., GLENDALE, CA:
4,014,728, PUB. 6-7-2011. INT. CL. 29.

FREESLATE, INC., SUNNYVALE, CA:
2,466,435, REN. 7-19-11. INT. CL. 9.

FREMAUX-DELORME, PARIS, FRANCE:
4,015,094, PUB. 6-7-2011. MULTIPLE CLASS, INT. CLS.
20, 24 AND 25.

FRENCH CONNECTION LIMITED, LONDON, UNITED
KINGDOM:
2,910,253, CANC. MULTIPLE CLASS, INT. CLS. 8, 11, 16,
20, 21, 24 AND 27.

FRESH EXPRESS INCORPORATED, SALINAS, CA:
2,910,811, CANC. INT. CL. 29.

FRESH PROCESSED OLIVE OIL, LLC, GARDEN CITY, NY:
4,014,683, PUB. 6-7-2011. INT. CL. 35.

FRESH WATER SYSTEMS, INC., SAN DIEGO, CA:
2,412,962, CANC. INT. CL. 11.

FREUDENBERG-NOK, PLYMOUTH, MI:
2,911,545, CANC. INT. CL. 7.

FREUDENBERG-NOK GENERAL PARTNERSHIP, PLY-
MOUTH, MI:
2,910,332, CANC. INT. CL. 17.

FRIATEC AKTIENGESELLSCHAFT, D-68222 MANNHEIM,
FED REP GERMANY:
2,481,211, REN. 7-15-11. INT. CL. 9.

FRIDAYPHOTOSCHOOL.COM INC., MONTGOMERY, IL:
4,015,514, PUB. 6-7-2011. INT. CL. 41.

FRIED, FRANK, HARRIS, SHRIVER & JACOBSON LLP,
NEW YORK, NY:
4,016,291, MULTIPLE CLASS, INT. CLS. 9, 16, 41 AND 45.

FRIEDMAN, CRAIG LOREN, WOODLAND HILLS, CA:
2,910,654, CANC. INT. CL. 38.

FRIESLAND BRANDS B.V., 7943 PE MEPPEL, NETHER-
LANDS:
1,649,605, REN. 7-15-11. INT. CL. 29.

FRITO-LAY NORTH AMERICA, INC., PLANO, TX:
4,016,986, MULTIPLE CLASS, INT. CLS. 29 AND 30.

FROMI FRANCE SARL, FRANCE:
4,014,501, PUB. 6-7-2011. INT. CL. 29.

FRONIUS INTERNATIONAL GMBH, A-4643 PETTEN-
BACH, AUSTRIA:
2,910,542, CANC. MULTIPLE CLASS, INT. CLS. 1, 6, 7, 9
AND 42.

FRONTIER SCIENTIFIC, INC., LOGAN, UT:
4,015,204, PUB. 6-7-2011. MULTIPLE CLASS, INT. CLS. 1,
40 AND 42.

FROST, JAMES A., OOLTEWAH, TN, DBA FROST CUT-
LERY:
2,513,966, REN. 7-16-11. INT. CL. 8.

FRUIT OF THE LOOM, INC., BOWLING GREEN, KY:
913,838, REN. 7-19-11. U.S. CL. 39 (INT. CLS. 10, 25 AND
26).

FRUTZZO, LLC, ALPINE, UT:
2,911,544, CANC. INT. CL. 32.

FRYMASTER L.L.C., SHREVEPORT, LA:
2,591,488, REN. 7-19-11. INT. CL. 11.

FSC FRANCHISE CO., LLC, TAMPA, FL:
4,014,357, PUB. 4-27-2010. INT. CL. 43.

FUJI INDUSTRIAL CO., LTD., KANAGAWA-KEN, JAPAN:
2,459,952, REN. 7-19-11. INT. CL. 11.

- FUJITSU NETWORK COMMUNICATIONS, INC., RICHARDSON, TX:
2,910,987, CANC. MULTIPLE CLASS, INT. CLS. 37, 38 AND 42.
- FUJITSU TECHNOLOGY SOLUTIONS INTELLECTUAL PROPERTY GMBH, FED REP GERMANY:
4,014,614, PUB. 6-7-2011. INT. CL. 9.
- FULTON, SAMANTHA, FISHKILL, NY:
4,015,819, PUB. 6-7-2011. INT. CL. 41.
- FULTON, STEPHEN C., MACON, GA:
4,015,635, PUB. 6-7-2011. INT. CL. 9.
- FUN COMMUNICATIONS GMBH, KARLSRUHE, FED REP GERMANY:
4,014,395, PUB. 6-7-2011. MULTIPLE CLASS, INT. CLS. 9, 35, 38, 41, 42 AND 45.
- FUNG, LEUNG WING, SHAU KEI WAN, HONG KONG:
2,910,455, CANC. INT. CL. 8.
- FUNVENTURES TRAVEL, LLC., INVER GROVE HEIGHTS, MN:
4,016,600, INT. CL. 39.
- FURMINATOR, INC., FENTON, MO:
4,016,939, MULTIPLE CLASS, INT. CLS. 3 AND 21.
- FUTURE ARCHITECT, INC., TOKYO, JAPAN:
2,480,436, REN. 7-15-11. MULTIPLE CLASS, INT. CLS. 35, 37 AND 42.
- FUTURE STARS SPORTS PHOTOGRAPHY INC., STONEY CREEK, CANADA:
4,014,249, PUB. 6-7-2011. MULTIPLE CLASS, INT. CLS. 16 AND 41.
- FVNB CORP., VICTORIA, TX:
2,911,074, CANC. INT. CL. 36.
- G & G DISTRIBUTION INC., PHOENIX, AZ, DBA RYAN'S PET SUPPLIES:
3,007,224, CANC. MULTIPLE CLASS, INT. CLS. 10, 18 AND 20.
- G & G MEDICAL PRODUCTS, LLC, BRIDGETON, NJ:
4,017,187, INT. CL. 5.
- G & R FOODS, INC., REEDSBURG, WI:
4,016,048, PUB. 6-7-2011. INT. CL. 29.
- G-III LEATHER FASHIONS, INC., NEW YORK, NY:
4,016,693, INT. CL. 9,
4,017,260, INT. CL. 25.
- GABA, MONIBERT NARITO, SAN DIEGO, CA, DBA NVO COMPONENTS AND GABA, DODI CECILE SHAW, SAN DIEGO, CA, DBA NVO COMPONENTS:
4,015,805, PUB. 6-7-2011. INT. CL. 12.
- GABET, RENEE A, LIGONIER, IN:
4,014,223, PUB. 6-7-2011. INT. CL. 14.
- GABRIEL TIRADO, PORT SAINT LUCIE, FL:
4,014,228, PUB. 6-7-2011. INT. CL. 41.
- GABRIELLE STUDIO, INC., NEW YORK, NY:
4,016,679, INT. CL. 25.
- GAETKE, HUBERT J., SAN JOSE, CA:
2,412,794, CANC. INT. CL. 20.
- GAINES, DANIELLE, LEBANON, NJ:
2,910,620, CANC. INT. CL. 35.
- GAINSBOROUGH HARDWARE INDUSTRIES LIMITED, BLACKBURN VICTORIA 3130, AUSTRALIA:
2,456,588, REN. 7-16-11. MULTIPLE CLASS, INT. CLS. 6 AND 21.
- GALAN ENTERPRISE INC, YORKVILLE, IL:
4,015,881, PUB. 6-7-2011. INT. CL. 41.
- GALLOPADE INTERNATIONAL, INC., PEACHTREE CITY, GA:
2,471,249, REN. 7-19-11. INT. CL. 16,
2,471,251, REN. 7-19-11. INT. CL. 16.
- GALLUZZO, JOHN J, BUFFALO, NY:
4,014,876, PUB. 6-7-2011. INT. CL. 30.
- GALOOTGEAR, INC., VALENCIA, CA:
4,016,987, MULTIPLE CLASS, INT. CLS. 21 AND 25,
4,016,988, INT. CL. 25,
4,016,989, MULTIPLE CLASS, INT. CLS. 21 AND 25,
4,017,036, MULTIPLE CLASS, INT. CLS. 21 AND 25.
- GAM AUDY, 33750 ST. GERMAIN DU PUCH, FRANCE:
2,909,496, CANC. INT. CL. 33.
- GAME ARTS CO., LTD., TOKYO, JAPAN:
4,016,403, INT. CL. 9.
- GAME PLANIT INTERACTIVE CORP., ELORA, ONTARIO:
2,468,276, REN. 7-19-11. INT. CL. 9.
- GAMELINE LLC, STAMFORD, CT:
2,910,765, CANC. INT. CL. 41.
- GAMMA PIU' S.R.L., CAZZAGO SAN MARTINO (BRES-CIA), ITALY:
2,909,812, CANC. INT. CL. 11.
- GANONG BROS. LIMITED, ST. STEPHEN, NEW BRUNSWICK E3L 2X5, CANADA:
2,427,828, REN. 7-19-11. INT. CL. 29.
- GANSUJUPENG INDUSTRY AND TRADE CO., LTD., CHINA:
4,014,514, PUB. 6-7-2011. MULTIPLE CLASS, INT. CLS. 29 AND 31.
- GANZ, WOODBRIDGE, ONTARIO L4L 3T2, CANADA:
2,554,518, REN. 7-21-11. INT. CL. 28.
- GARBUIO S.P.A. 30138 PAESE, ITALY:
2,411,849, CANC. MULTIPLE CLASS, INT. CLS. 7, 9 AND 11.
- GARCIA, SR., NICHOLAS, FAYETTEVILLE, GA:
4,015,587, PUB. 6-7-2011. INT. CL. 41.
- GARD, GERALD, MOUNT DORA, FL:
4,016,968, MULTIPLE CLASS, INT. CLS. 6 AND 21.
- GARFINKEL, KENNETH A., TORONTO, CANADA, DBA WHOOSH!, AND ENVIROSTREME SOLUTIONS AND KIRSCHNER, JULIUS, TORONTO, CANADA, DBA WHOOSH!, AND ENVIROSTREME SOLUTIONS:
4,014,419, PUB. 6-7-2011. INT. CL. 3.
- GARMON CORPORATION, TEMECULA, CA:
4,015,759, PUB. 6-7-2011. MULTIPLE CLASS, INT. CLS. 3 AND 5.
- GARY PLATT MANUFACTURING, LLC, RENO, NV:
4,015,707, PUB. 6-7-2011. INT. CL. 20.
- GASPARI NUTRITION, INC., LAKEWOOD, NJ:
4,016,979, INT. CL. 5.
- GASPEDAL LLC, CHICAGO, IL:
2,469,567, REN. 7-18-11. INT. CL. 35.
- GATES CORPORATION, THE, DENVER, CO, GATES RUBBER COMPANY, THE, DENVER, CO:
549,898, REN. 7-19-11. U.S. CL. 35 (INT. CLS. 7, 12 AND 17).
- GATES, JOHN FITZGERALD, NEW YORK, NY, DBA CRITICALITY MANAGEMENT CONSULTING:
4,016,667, INT. CL. 35.
- GE MONEY BANK, SALT LAKE CITY, UT:
4,015,574, PUB. 6-7-2011. INT. CL. 36.
- GEARENCH, INC., CLIFTON, TX:
1,154,616, REN. 7-18-11. INT. CL. 8.
- GEBAUER COMPANY, CLEVELAND, OH:
4,014,350, PUB. 6-7-2011. MULTIPLE CLASS, INT. CLS. 3 AND 5.
- GEFION RECORDS APS, DK-2830 VIRUM, DENMARK:
4,016,697, INT. CL. 9.
- GEHEGAN & ASSOCIATES, SAN DIEGO, CA:
4,015,860, PUB. 6-7-2011. INT. CL. 35.
- GEMMA, ANTHONY, LINCOLN, RI:
4,015,467, PUB. 6-7-2011. MULTIPLE CLASS, INT. CLS. 35 AND 41.
- GEMOLOGICAL INSTITUTE OF AMERICA, INC., CARLSBAD, CA:
2,478,468, REN. 7-15-11. INT. CL. 9.
- GENAUDIO, INC., CENTENNIAL, CO:
4,016,178, MULTIPLE CLASS, INT. CLS. 35 AND 41.
- GENAUDIO, INC., ENGLEWOOD, CO:
4,016,179, MULTIPLE CLASS, INT. CLS. 35 AND 41.
- GENAUDIO, INC., CENTENNIAL, CO:
4,016,180, MULTIPLE CLASS, INT. CLS. 35 AND 41,
4,016,181, MULTIPLE CLASS, INT. CLS. 35 AND 41,
4,016,182, MULTIPLE CLASS, INT. CLS. 35 AND 41,
4,016,183, MULTIPLE CLASS, INT. CLS. 35 AND 41.
- GENERAL ELECTRIC CAPITAL CORPORATION, AS AGENT, CHICAGO, IL:
2,911,081, CANC. INT. CL. 44.
- GENERAL ELECTRIC COMPANY, SCHENECTADY, NY:
2,467,172, REN. 7-17-11. INT. CL. 9,
2,911,607, CANC. INT. CL. 36.

GENERAL FOAM PLASTICS CORPORATION, NORFOLK, VA:
4,017,361, INT. CL. 28.

GENERAL KINEMATICS CORPORATION, CRYSTAL LAKE, IL:
1,651,339, REN. 7-18-11. INT. CL. 7.

GENERAL MILLS, INC., MINNEAPOLIS, MN:
1,666,000, REN. 7-15-11. INT. CL. 30.
4,016,788, INT. CL. 30.

GENERAL MOTORS LLC, DETROIT, MI:
2,911,123, CANC. INT. CL. 36.

GENERAL RE CORPORATION, STAMFORD, CT:
2,909,990, CANC. INT. CL. 16.

GENERATIONS CREDIT UNION, OLYMPIA, WA:
2,910,914, CANC. INT. CL. 36.

GENETICS & IVF INSTITUTE, FAIRFAX, VA:
4,014,365, PUB. 6-7-2011. INT. CL. 44.

GENKI MEDIA LLC, WASHINGTON, DC:
4,015,487, PUB. 6-7-2011. INT. CL. 41.

GENOLOGICS LIFE SCIENCES SOFTWARE INC., VICTORIA, B.C., CANADA:
3,585,915, CANC. INT. CL. 9.

GENOMAR AS, OSLO, NORWAY:
4,014,367, PUB. 6-7-2011. MULTIPLE CLASS, INT. CLS. 29 AND 31.
4,014,368, PUB. 6-7-2011. MULTIPLE CLASS, INT. CLS. 29 AND 31.
4,014,369, PUB. 6-7-2011. MULTIPLE CLASS, INT. CLS. 29 AND 31.
4,014,370, PUB. 6-7-2011. MULTIPLE CLASS, INT. CLS. 29 AND 31.

GENPRO POWER SYSTEMS, INC., RAPID CITY, SD:
4,016,579, INT. CL. 11.

GENUINE FIRST AID LLC, CLEARWATER, FL:
4,016,389, INT. CL. 5.

GENUINE GEMS CORP., FORT LEE, NJ:
2,759,681, CANC. INT. CL. 14.

GEO MEDICAL CO., LTD., REPUBLIC OF KOREA:
4,014,603, PUB. 6-7-2011. INT. CL. 9.

GEOFFREY, LLC, WAYNE, NJ:
4,017,248, INT. CL. 25.

GEORGEBRA, INC., PLANTATION, FL:
4,014,233, PUB. 6-7-2011. INT. CL. 9.

GEORGE LITTLE MANAGEMENT, LLC, WHITE PLAINS, NY:
2,910,011, CANC. INT. CL. 35.

GEORGIA NUT COMPANY, SKOKIE, IL:
4,016,797, INT. CL. 29.

GEOSPATIAL TECHNOLOGIES, INC., SANTA ANA, CA:
2,516,839, REN. 7-15-11. INT. CL. 9.

GERSTEN SAVAGE LLP, NEW YORK, NY:
4,016,644, INT. CL. 45.

GET A MOVE ON, INC., WICHITA, KS:
3,106,304, COR. INT. CL. 39.

GETTY, WILLIAM, PERRIS, CA:
4,015,711, PUB. 6-7-2011. INT. CL. 12.

GFY ENTERTAINMENT, INC., RALEIGH, NC, DBA GFY POKER NIGHTS:
4,016,618, INT. CL. 41.

GIANT BRANDS, INC., WILMINGTON, DE:
2,909,444, CANC. MULTIPLE CLASS, INT. CLS. 9 AND 16.

GIANTOMAS INC., OVIEDO, FL:
4,016,728, INT. CL. 35.

GIBBON AMERICA II CORPORATION, ELGIN, IL:
2,411,642, CANC. INT. CL. 2.

GIBBS-NORTAC INDUSTRIES LTD., DELTA, B.C., CANADA:
4,014,953, PUB. 6-7-2011. INT. CL. 28.
4,014,954, PUB. 6-7-2011. INT. CL. 35.

GIBSON GUITAR CORP., NASHVILLE, GA:
2,482,206, REN. 7-19-11. INT. CL. 15.

GIBSON, REGINALD E., DOUGLASVILLE, GA:
4,015,489, PUB. 6-7-2011. INT. CL. 41.

GIBSON, THOMAS, WASHINGTON, DC:
2,911,588, CANC. INT. CL. 35.

GIFTCO, INC., VERNON HILLS, IL:
2,412,799, CANC. INT. CL. 36.

GILMAR S.P.A., RIMINI, ITALY:
2,909,353, CANC. MULTIPLE CLASS, INT. CLS. 18 AND 25.

GIORDANO'S ENTERPRISES, INC., CHICAGO, IL:
1,160,481, REN. 7-21-11. INT. CL. 42.

GIPSON, LANCE, COMPTON, CA AND INGRAM, EVAN, COMPTON, CA AND BROWN, DEREK, COMPTON, CA:
4,015,840, PUB. 6-7-2011. INT. CL. 25.

GIRANDOLE ENTERPRISES, LLC, ISSAQUAH, WA, DBA DWAFFLER:
2,496,014, REN. 7-20-11. INT. CL. 9.

GIRAUD MONIQUE, FRANCE:
2,964,316.

GIRLFRIENDS ONLY, G.P., RADNOR, PA:
2,909,756, CANC. INT. CL. 35.

GISCOUNTS INC, CAMPBELL, CA:
4,016,052, PUB. 6-7-2011. INT. CL. 35.

GISER S.R.L., ITALY:
4,014,558, PUB. 6-7-2011. INT. CL. 25.

GL INDUSTRIAL SERVICES USA, INC., MECHANICSBURG, PA:
2,412,523, CANC. INT. CL. 42.

GLACIER REINSURANCE AG, CH-8808 PFÄFFIKON SZ, SWITZERLAND:
3,635,447, CANC. MULTIPLE CLASS, INT. CLS. 35 AND 36.

GLANBIA PLC, KILKENNY, IRELAND:
4,016,372, INT. CL. 29.

GLAXOSMITHKLINE LLC, WILMINGTON, DE:
2,413,046, CANC. MULTIPLE CLASS, INT. CLS. 16 AND 42.

GLENBEIGH HOSPITAL AND OUTPATIENT CENTERS, ROCK CREEK, OH:
2,910,027, CANC. INT. CL. 44.

GLENN ZANDERS FUR & SPORTING GOODS CO., SPARTA, IL AND DKG TRADING, INC., EVANSVILLE, IL:
4,015,870, PUB. 6-7-2011. INT. CL. 9.

GLOBAL BUSINESS INTEGRATOR, INC., DORAL, FL:
4,015,917, PUB. 6-7-2011. INT. CL. 35.

GLOBAL CORPORATION, BOCA RATON, FL:
2,479,315, REN. 7-21-11. INT. CL. 5.

GLOBAL FABRICATION SERVICES, INC., HOUSTON, TX:
2,585,440, REN. 7-15-11. INT. CL. 40.

GLOBAL FINANCIAL SERVICES, L.L.C., HOUSTON, TX:
2,584,273, REN. 7-16-11. INT. CL. 36.

GLOBAL FREQUENCY MUSIC LLC, NEW YORK, NY:
4,017,175, MULTIPLE CLASS, INT. CLS. 9, 25 AND 41.

GLOBAL HOTELS & RESORTS IP BV, CURACAO, NETHERLANDS ANTILLES:
3,942,547, AM. MULTIPLE CLASS, INT. CLS. 35, 36, 43 AND 45.

GLOBAL LEISURE PARTNERS LLP, LONDON, UNITED KINGDOM:
4,014,964, PUB. 6-7-2011. INT. CL. 36.

GLOBAL MEDICAL DIRECTORY, VAN NUYS, CA:
4,015,047, PUB. 6-7-2011. INT. CL. 35.

GLOBAL MENTORS, LLC, EAST LANSING, MI:
4,015,593, PUB. 6-7-2011. INT. CL. 41.

GLOBAL MICA, INC., ATLANTA, GA:
4,017,106, INT. CL. 43.

GLOBAL QUEST INTERNATIONAL, INC., PORT LUDLON, WA:
2,909,376, CANC. MULTIPLE CLASS, INT. CLS. 39 AND 42.

GLOBAL QUEST INTERNATIONAL, INC., PORT LUDLOW, WA:
2,909,377, CANC. INT. CL. 39.

GLOBAL RANCH, LLC, SAN DIEGO, CA:
4,017,289, INT. CL. 35.

GLOBAL SECURITY TRACKING, INC., WORCESTER, MA:
4,017,400, INT. CL. 9.

GLOBALQUEST, L.L.C., HOPEWELL, NJ:
2,909,851, CANC. INT. CL. 35.

GLOBALQUEST, LLC, HOPEWELL, NJ:
2,911,268, CANC. INT. CL. 16.

GLOBE NEW MEDIA INC., WEST ORANGE, NJ:
4,015,588, PUB. 6-7-2011. INT. CL. 16.

- GLOBE UNION INDUSTRIAL CORP., TAIWAN, CHINA:
2,464,655. REN. 7-15-11. MULTIPLE CLASS, INT. CLS. 11 AND 21.
- GLOBERIDE, INC., HIGASHIKURUME-CITY, TOKYO, JAPAN:
2,474,271. REN. 7-15-11. INT. CL. 28.
- GLOBOMAX HOLDINGS LLC, HANOVER, MD:
2,909,620. CANC. MULTIPLE CLASS, INT. CLS. 9 AND 42.
- GLOZAL, INC., MIAMI, FL, FORMERLY REALTORBOOK, INC.:
4,015,191, PUB. 6-7-2011. INT. CL. 45.
- GLUMAC, DANIJEL, INDIANAPOLIS, IN:
4,015,411, PUB. 6-7-2011. INT. CL. 16.
- GMA ACCESSORIES, INC., NEW YORK, NY:
2,412,360, CANC. INT. CL. 25.
2,412,362, CANC. INT. CL. 3.
- GMAC MORTGAGE, LLC, HORSHAM, PA:
2,910,065, CANC. INT. CL. 36.
2,910,069, CANC. INT. CL. 36.
- GOELST INTERNATIONAL, LLC, WINSTON-SALEM, NC:
2,412,601, CANC. INT. CL. 20.
- GOLD LINE TELEMAGEMENT INC., RICHMOND HILL, CANADA:
4,016,170, MULTIPLE CLASS, INT. CLS. 41 AND 42.
- GOLD SYSTEMS, INC., BOULDER, CO:
4,016,032, PUB. 6-7-2011. INT. CL. 42.
- GOLDEN FRANCHISING CORPORATION, RICHARDSON, TX:
2,432,483. REN. 7-20-11. INT. CL. 42.
- GOLDEN FROG, INC., GRAND CAYMAN, CAYMAN ISLANDS:
4,016,651, INT. CL. 9.
- GOLDEN HIRE EQUITY, LLC, LAKEVIEW, NY:
2,910,109, CANC. INT. CL. 30.
- GOLDEN ISLES MEDICAL, INC., ST. SIMONS ISLAND, GA:
4,016,044, PUB. 6-7-2011. INT. CL. 5.
- GOLDEN SUN, INC., SANTA CLARITA, CA:
2,412,211, CANC. INT. CL. 5.
- GOLDEN TOUCH IMPORTS, INC., NEW YORK, NY:
4,016,504, INT. CL. 25.
- GOLDMAN, SACHS & CO., NEW YORK, NY:
2,412,167, CANC. INT. CL. 9.
4,017,181, INT. CL. 36.
- GOLDSTEIN, IRA, RALEIGH, NC AND GOLDSTEIN, DAVID, RALEIGH, NC:
4,016,759, INT. CL. 17.
- GOLDSTEIN, ROBERT, RICHLAND, WA:
4,015,812, PUB. 6-7-2011. INT. CL. 9.
- GOMEZ, MARIA, MIAMI BEACH, FL:
4,015,778, PUB. 6-7-2011. INT. CL. 41.
- GON BOPS INC., MARSHFIELD, MA:
2,463,171. REN. 7-18-11. INT. CL. 15.
4,016,919, INT. CL. 15.
- GONZALES, DAVID PEREZ, MILWAUKEE, WI, DBA LATIN BOSS CLOTHING:
4,017,424, INT. CL. 25.
- GOOD EARTH LIGHTING, INC., WHEELING, IL:
4,014,262, PUB. 6-7-2011. INT. CL. 11.
- GOOD VIBRATIONS, INC., LOS ANGELES, CA TO R & H DESIGNS, INC., CHATSWORTH, CA:
1,186,186, CANC. INT. CL. 42.
- GOODMAN, MICHELE I., LITCHFIELD PARK, AZ:
4,016,645, INT. CL. 21.
- GOODWILL COMMUNITY FOUNDATION, INC., DURHAM, NC:
4,015,198, PUB. 6-7-2011. INT. CL. 41.
- GOODWILL INDUSTRIES OF THE VALLEYS, INC., ROANOKE, VA:
4,015,390, PUB. 6-7-2011. MULTIPLE CLASS, INT. CLS. 35 AND 36.
- GOODYEAR TIRE & RUBBER COMPANY, THE, AKRON, OH:
2,480,581. REN. 7-18-11. MULTIPLE CLASS, INT. CLS. 35 AND 37.
- GOOGLE INC., MOUNTAIN VIEW, CA:
4,016,470, MULTIPLE CLASS, INT. CLS. 9 AND 42.
- GORDON FOOD SERVICE, GRAND RAPIDS, MI:
2,910,335, CANC. INT. CL. 29.
- GORDON MANAGEMENT PARTNERS, LLC, GREER, SC:
4,014,344, PUB. 12-7-2010. INT. CL. 9.
- GORILLA FUEL, LLC, TEMPE, AZ:
2,910,599, CANC. INT. CL. 39.
- GORTON'S INC., GLOUCESTER, MA:
4,016,447, INT. CL. 29.
- GOUGH, STEPHEN JOHN, AVON, NJ, DBA EASY WAGON WHEEL BRACKETS/EASY CART WHEEL BRACKETS:
1,651,315. REN. 7-16-11. INT. CL. 6.
- GPB INTERNATIONAL LIMITED, TORTOLA, BR. VIRGIN ISLANDS:
2,909,536, CANC. INT. CL. 9.
- GR.A.M.M. GRUPPO ALIMENTARE MEDITERRANEO MILO S.R.L., PALOMBAIO - BITONTO, ITALY:
4,016,930, INT. CL. 30.
- GRACE HAWTHORNE, MILL VALLEY, CA:
4,016,783, MULTIPLE CLASS, INT. CLS. 16 AND 28.
- GRACO MINNESOTA INC., MINNEAPOLIS, MN:
4,015,432, PUB. 6-7-2011. INT. CL. 7.
- GRAHAM WEBB INTERNATIONAL, INC., CARLSBAD, CA:
2,910,309, CANC. INT. CL. 3.
- GRAND FINALE, INC., LOS ANGELES, CA:
2,911,425, CANC. INT. CL. 21.
- GRAND HALL USA, INC., GARLAND, TX:
4,016,258, INT. CL. 11.
- GRANDMA HOERNER'S FOODS, INC, ALMA, KS:
4,016,161, INT. CL. 29.
- GRANGE PARK CAPITAL MANAGEMENT, L.P., GREEN-WHICH, CT:
2,911,396, CANC. INT. CL. 36.
- GRANVILLE HOMES, INC., FRESNO, CA:
4,015,862, PUB. 6-7-2011. MULTIPLE CLASS, INT. CLS. 36 AND 37.
- GRAPHIC CONVERTING, INC., ELMHURST, IL:
2,490,842. REN. 7-20-11. MULTIPLE CLASS, INT. CLS. 35, 40 AND 42.
- GRAUER, KIM B., EVANSVILLE, IN:
2,910,176, CANC. INT. CL. 30.
- GREAT AMERICAN GROUP, LLC, WOODLAND HILLS, CA:
4,016,981, INT. CL. 35.
4,016,982, INT. CL. 35.
- GREAT EARTH COMPANIES, INC., FARMINGDALE, NY:
2,413,079, CANC. INT. CL. 5.
- GREAT LAKES DREDGE AND DOCK COMPANY, OAK-BROOK, IL:
2,468,607. REN. 7-15-11. INT. CL. 37.
- GREAT LAKES ELECTRIC LLC, STEVENSVILLE, MI:
4,016,673, INT. CL. 11.
- GREAT RANGE CAPITAL, LLC, LEAWOOD, KS:
4,015,159, PUB. 6-7-2011. INT. CL. 36.
- GREAT SAFARIS, LLC, GLENDALE, CA:
4,017,362, INT. CL. 39.
- GREATHINGS, INC., WICHITA, KS:
4,015,403, PUB. 6-7-2011. INT. CL. 20.
- GREEK BOYS CHOICE, INC., TARPON SPRINGS, FL:
4,016,948, INT. CL. 29.
- GREEK ISLAND LABS, LLC, SCOTTSDALE, AZ:
4,014,210, PUB. 6-7-2011. INT. CL. 3.
- GREEN COCO HOLDING AG, CH-4053 BASEL, SWITZERLAND:
4,014,517, PUB. 6-7-2011. INT. CL. 32.
- GREEN HILL HEALTHCARE COMMUNICATIONS, LLC, MONROE TOWNSHIP, NJ:
4,017,379, INT. CL. 16.
4,017,380, INT. CL. 35.
4,017,381, INT. CL. 41.
- GREEN PARTS, CORP., MARYSVILLE, WA:
2,909,511, CANC. MULTIPLE CLASS, INT. CLS. 7, 9, 11 AND 12.
- GREEN SHERRY, CARROLLTON, TX:
4,016,792, INT. CL. 37.
4,016,793, INT. CL. 37.
- GREEN TEXTBOOKS, LLC, SANDY, UT, DBA GREEN TEXTBOOKS:
4,017,354, INT. CL. 35.

- GREEN TURTLE AMERICAS LTD., CHARLOTTE, NC:
4,016,259, INT. CL. 11.
- GREEN, WILLIAM J., OSAGE BEACH, MO, DBA LURE-
TRADER:
4,017,401, INT. CL. 35.
- GREENHOUSE GROWN FOODS INC., BRITISH COLUM-
BIA, CANADA:
4,014,854, PUB. 6-7-2011. INT. CL. 31.
- GREENLEES FILTER, LLC., FOREST PARK, IL:
4,016,729, INT. CL. 7.
4,016,730, INT. CL. 7.
- GREY GLOBAL GROUP INC., NEW YORK, NY, GREY
GLOBAL GROUP INC., NEW YORK, NY:
2,474,059, REN. 7-18-11. MULTIPLE CLASS, INT. CLS. 35
AND 41.
- GREYNIUM INFORMATION TECHNOLOGIES PVT. LTD.,
BANGALORE, INDIA:
4,015,988, PUB. 6-7-2011. MULTIPLE CLASS, INT. CLS. 41
AND 42.
- GRIFFCO VALVE INC., MIDDLEPORT, NY:
2,909,989, CANC. INT. CL. 7.
- GRIFFIN LABORATORIES, TEMECULA, CA:
4,014,243, PUB. 6-7-2011. INT. CL. 10.
4,014,244, PUB. 6-7-2011. INT. CL. 10.
- GRILLAGAS LLC, SEGUIN, TX:
4,014,901, PUB. 6-7-2011. INT. CL. 4.
4,014,902, PUB. 6-7-2011. INT. CL. 4.
- GRINDERS AND SUCH, INC., MINERVA, OH, GRINDERS
DELUXE, INC., CANTON, OH:
1,661,862, REN. 7-19-11. INT. CL. 30.
- GRM ENTERPRISES, INC., UNION, NJ:
2,909,470, CANC. INT. CL. 39.
- GROHE AG, D-58675 HEMER, FED REP GERMANY:
2,976,681, CANC. INT. CL. 21.
- GROSGEBAUER; CLARE H., FAIRFAX, VA, DBA SMALL
WONDERS ENTERPRISES:
1,188,770, REN. 7-18-11. INT. CL. 28.
1,188,771, REN. 7-18-11. INT. CL. 28.
- GROTE, CAROLYN R., BERKELEY, CA, DBA VILLE ET
VILLAGE:
2,477,845, REN. 7-19-11. INT. CL. 42.
- GROUNDS FOR A BETTER WORLD, LLC, MIDLAND, MI:
4,015,642, PUB. 6-7-2011. INT. CL. 43.
- GROUPE PROCYCLE INC. / PROCYCLE GROUP INC.,
BEAUCE, QUEBEC, CANADA:
2,909,518, CANC. INT. CL. 12.
- GROWMARK, INC., BLOOMINGTON, IL:
2,412,062, CANC. INT. CL. 42.
- GROWSEED AKTIENGESELLSCHAFT, 9490 VADUZ,
LIECHTENSTEIN:
2,910,384, CANC. INT. CL. 30.
- GRUPO BIMBO, S.A. B. DE C.V., MEXICO CITY, MEXICO:
2,535,259, REN. 7-18-11. INT. CL. 30.
4,014,946, PUB. 3-15-2011. INT. CL. 30.
- GRUPO BIMBO, S.A.B. DE C.V., MEXICO CITY, MEXICO:
4,014,260, PUB. 6-7-2011. INT. CL. 30.
- GRUPO OMOR, S.A. DE C.V., COLONIA NOCHEBUENA,
MEXICO:
2,471,003, REN. 7-16-11. MULTIPLE CLASS, INT. CLS. 29
AND 30.
- GSL RESEARCH TECHNOLOGY LIMITED, TORTOLA,
BR. VIRGIN ISLANDS:
2,575,006, REN. 7-18-11. INT. CL. 9.
- GTECH RHODE ISLAND CORPORATION, PROVIDENCE,
RI:
2,910,649, CANC. INT. CL. 38.
- GTL FUEL, LLC, PORT ST LUCIE, FL:
4,016,028, PUB. 6-7-2011. INT. CL. 32.
- GTRC SERVICES, INC., WESTLAKE VILLAGE, CA:
2,470,898, REN. 7-16-11. INT. CL. 9.
- GUANGZHOU VANTA PACKING MACHINERY CO., LTD.,
GUANGZHOU, GUANGDONG, CHINA:
4,015,896, PUB. 6-7-2011. INT. CL. 7.
- GUCCI AMERICA, INC., NEW YORK, NY:
4,016,319, INT. CL. 18.
- GUERLAIN S.A., 75008 PARIS, FRANCE:
2,412,881, CANC. INT. CL. 3.
- GUERRA, RENE HECTOR GARZA, NUEVO LEON, MEX-
ICO:
2,910,276, CANC. INT. CL. 12.
- GUILLOTTE, SUSAN, URBANNA, VA:
4,017,357, INT. CL. 42.
- GUIMOND, BRUCE, HERMON, ME:
4,016,846, INT. CL. 30.
- GUINNESS UDV NORTH AMERICA, INC., NORWALK, CT,
HEUBLEIN, INC., HARTFORD, CT, DBA THE POPOV
DISTILLING CO.:
725,706, REN. 7-20-11. U.S. CL. 49 (INT. CL. 33).
- GUITAR CENTER, INC., WESTLAKE VILLAGE, CA:
4,016,333, INT. CL. 35.
- GUN DOCK, LLC, PHOENIX, AZ:
4,015,437, PUB. 6-7-2011. INT. CL. 13.
- GUNTUR, RADHA, NEW YORK, NY:
4,015,783, PUB. 6-7-2011. INT. CL. 41.
- GUST, DAVID, CHICAGO, IL:
4,016,215, INT. CL. 10.
- GUSTAV NEUHAUSER PRAEZISIONSWERKZEUGFAB-
RIK GMBH, PRUEM, FED REP GERMANY, GUSTAV
NEUHAUSER PRAEZISIONSWERKZEUGFABRIK O.H.G.,
MUEHLACKER 4, FED REP GERMANY:
1,166,122, REN. 7-16-11. INT. CL. 7.
- GUTTER CLUTTER BUSTER, LLC., SARASOTA, FL:
4,015,616, PUB. 6-7-2011. INT. CL. 7.
- GUTTERMATE SYSTEMS, LLC, CUMMING, GA:
4,015,816, PUB. 6-7-2011. INT. CL. 6.
- GVBB HOLDINGS S.A.R.L., LUXEMBOURG, LUXEM-
BOURG:
2,479,445, REN. 7-19-11. INT. CL. 9.
- GYPSY 05, INC., LOS ANGELES, CA:
4,016,896, INT. CL. 25.
- H & S AUTOSHOT MFG. CO. LTD., GEORGETOWN,
ONTARIO, CANADA:
4,014,349, PUB. 6-7-2011. INT. CL. 11.
- H. J. HEINZ COMPANY, L.P., PITTSBURGH, PA, THERMO
PAC ASSOCIATES, LTD., STONE MOUNTAIN, GA:
1,669,910, REN. 7-18-11. INT. CL. 29.
- H.D.D. LLC, HEALDSBURG, CA, DBA TRUETT HURST
WINERY:
4,017,219, INT. CL. 33.
- H.U.G.S. ME, LLC, MURFREESBORO, TN:
2,910,367, CANC. MULTIPLE CLASS, INT. CLS. 6, 14, 16,
18, 21 AND 25.
- H&O DISTRIBUTION, INC., FAIRFIELD, OH, AKA OS-
BORNE TRUCKING COMPANY:
4,017,322, INT. CL. 35.
- HAANSOFT INC., SEOUL, REPUBLIC OF KOREA:
4,014,721, PUB. 6-7-2011. MULTIPLE CLASS, INT. CLS. 9
AND 42.
- HABAND COMPANY, INC., OAKLAND, NJ:
2,457,017, REN. 7-15-11. INT. CL. 25.
- HABERSHAM METAL PRODUCTS COMPANY, CORNE-
LIA, GA:
2,563,330, REN. 7-15-11. INT. CL. 6.
- HACKFORTH GMBH, FED REP GERMANY:
4,014,493, PUB. 6-7-2011. MULTIPLE CLASS, INT. CLS. 7,
12 AND 37.
- HACKFWD GMBH & CO. KG, FED REP GERMANY:
4,014,560, PUB. 6-7-2011. MULTIPLE CLASS, INT. CLS.
35, 36 AND 42.
- 4,014,561, PUB. 6-7-2011. MULTIPLE CLASS, INT. CLS.
35, 36 AND 42.
- HACKNEY PARKER, WRIGHTSVILLE BEACH, NC:
4,015,646, PUB. 6-7-2011. INT. CL. 31.
- HAGEST, CHRIS, LAKE HAVASU CITY, AZ:
4,015,806, PUB. 6-7-2011. INT. CL. 12.
- HAIR ON WHEELS, INC., LONGMONT, CO:
2,909,973, CANC. INT. CL. 44.
- HALL, KATHLEEN A., CLARKESVILLE, GA:
4,016,269, INT. CL. 16.
- HALL, MARRIANNE, ANN ARBOR, MI:
4,016,840, INT. CL. 28.
- HALLSTEIN, PHIL, SAN RAFAEL, CA:
2,470,903, REN. 7-15-11. INT. CL. 41.
- HALO INNOVATIONS, INC., MINNETONKA, MN:
4,016,929, INT. CL. 25.

- HALPERN, STEVEN, SAN ANSELMO, CA, DBA SOUND RX:
2,512,276. REN. 7-18-11. INT. CL. 9.
- HAMIDA PHARMA, INC, IRVINE, CA:
4,014,880. PUB. 6-7-2011. INT. CL. 5.
- HAMILTON, DEBRA A, PONTE VEDRA BEACH, FL, DBA WORKING LIKE A DOG:
4,015,037. PUB. 6-7-2011. INT. CL. 25.
- HAMILTON, IAN BLAIR, BYRON BAY, NSW, AUSTRALIA:
4,014,939. PUB. 6-7-2011. INT. CL. 11.
- HAMMER, KEVIN, EAST BOSTON, MA AND CONNELL, JOSHUA, EAST BOSTON, MA:
2,910,350. CANC. INT. CL. 9.
- HAMPTON CITY PUBLIC SCHOOLS, HAMPTON, VA:
2,910,169. CANC. INT. CL. 25.
- HAN, MICHAEL, WASHINGTON, DC:
4,016,437. INT. CL. 35.
- HANDS ON INTERNATIONAL, LLC, MASON, OH:
4,014,796. PUB. 6-7-2011. MULTIPLE CLASS, INT. CLS. 9 AND 21.
- HANEY, SHARON, PIQUA, OH AND HANEY, JERALD, PIQUA, OH:
2,910,426. CANC. INT. CL. 44.
- HANG ZHOU JIE HAO GONG MAO YOU XIAN GONG SI, CHINA:
4,014,563. PUB. 6-7-2011. MULTIPLE CLASS, INT. CLS. 7 AND 8.
- HANNAH'S HOME, MENTOR, OH:
2,590,850. REN. 7-18-11. INT. CL. 42.
2,590,851. REN. 7-18-11. INT. CL. 42.
- HANS A. VAN AANHOLT, NETHERLANDS:
4,014,495. PUB. 6-7-2011. MULTIPLE CLASS, INT. CLS. 9 AND 25.
- HANSEN BEVERAGE COMPANY, CORONA, CA:
4,014,306. PUB. 6-7-2011. MULTIPLE CLASS, INT. CLS. 5 AND 32.
- HAPPICH GMBH, WUPPERTAL, FED REP GERMANY, GEBRUEDER HAPPICH GMBH., WUPPERTAL-ELBERFELD, FED REP GERMANY:
909,892. REN. 7-19-11. U.S. CL. 4 (INT. CL. 3).
- HARD AND SHINY S.R.L., ITALY:
4,014,497. PUB. 6-7-2011. MULTIPLE CLASS, INT. CLS. 3, 9, 14, 18 AND 25.
- HARD ROCK CAFE INTERNATIONAL (USA), INC., ORLANDO, FL:
4,017,047. INT. CL. 3.
- HARDCANDY CASES, LLC, DANVILLE, CA:
4,016,801. INT. CL. 9.
- HARDEN THERAPY LLC, AUSTIN, TX, DBA MBS REHAB:
4,015,648. PUB. 6-7-2011. INT. CL. 9.
4,015,649. PUB. 6-7-2011. INT. CL. 9.
- HARDY DEBBIE MARTINE, BROOKLYN, NY:
4,014,372. PUB. 6-7-2011. INT. CL. 25.
- HARLAND CLARKE CORP., SAN ANTONIO, TX:
2,911,642. CANC. MULTIPLE CLASS, INT. CLS. 16, 35, 40 AND 45.
- HARMONIX MUSIC SYSTEMS, INC., CAMBRIDGE, MA:
4,016,892. INT. CL. 16.
- HARPER COLLINS PUBLISHERS LTD., GLASGOW G64 2QT, SCOTLAND:
1,648,817. REN. 7-16-11. INT. CL. 16.
- HARPER INDUSTRIES, INC., HARPER, KS:
2,412,298. CANC. INT. CL. 7.
- HARRIS COUNTY CRIMINAL LAWYERS ASSOCIATION, HOUSTON, TX, AKA HCCLA:
4,015,523. PUB. 6-7-2011. INT. CL. 35.
- HARRISON, SUSAN L., LUBBOCK, TX:
4,017,065. INT. CL. 26.
- HARRY MILLER CORP., PHILADELPHIA, PA:
4,014,231. PUB. 6-7-2011. INT. CL. 4.
4,014,232. PUB. 6-7-2011. INT. CL. 4.
4,014,234. PUB. 6-7-2011. INT. CL. 2.
4,014,236. PUB. 6-7-2011. INT. CL. 4.
- HARRY WINSTON HOPE FOUNDATION, INC., A WHOLLY-OWNED SUBSIDIARY OF HARRY WINSTON, INC., NEW YORK, NY:
4,015,565. PUB. 6-7-2011. INT. CL. 36.
- HARTFORD FIRE INSURANCE COMPANY, HARTFORD, CT:
4,014,738. PUB. 6-7-2011. INT. CL. 42.
- HARTMANN USA, INC., ROCK HILL, SC:
2,476,518. REN. 7-15-11. INT. CL. 10.
- HARTMANN, GREGORY P., BOULDER, CO:
2,911,645. CANC. MULTIPLE CLASS, INT. CLS. 25 AND 43.
- HARU HOLDING CORP., MIAMI, FL:
2,546,193. REN. 7-15-11. INT. CL. 42.
- HARWOOD INDUSTRIES S.A., BR. VIRGIN ISLANDS:
4,014,646. PUB. 6-7-2011. INT. CL. 11.
- HARWOOD INTERNATIONAL INCORPORATED, DALLAS, TX:
4,016,176. MULTIPLE CLASS, INT. CLS. 36 AND 37.
- HASBRO, INC., PAWTUCKET, RI:
4,015,673. PUB. 6-7-2011. INT. CL. 28.
- HAVEN ENTERPRISES, INC., THE WOODLANDS, TX, CARE-FREE PLANT POTS INCORPORATED, HOUSTON, TX:
1,161,981. REN. 7-21-11. INT. CL. 21.
- HAVRAN, LEIGHANN, STANTON, CA AND HAVRAN, MARC, STANTON, CA:
4,015,927. PUB. 6-7-2011. INT. CL. 35.
- HAWA GMBH & CO. KG, WAIN, FED REP GERMANY:
1,626,659. CANC. MULTIPLE CLASS, INT. CLS. 6, 9 AND 20.
- HAYWARD INDUSTRIES, INC., ELIZABETH, NJ:
4,016,737. MULTIPLE CLASS, INT. CLS. 7, 9 AND 11.
- HAZAN, RITA, NEW YORK, NY:
4,016,162. INT. CL. 3.
- HEAC, INC., HOUSTON, TX:
2,457,265. REN. 7-18-11. INT. CL. 6.
- HEADSPACE MEDITATION LIMITED, UNITED KINGDOM:
4,014,510. PUB. 6-7-2011. MULTIPLE CLASS, INT. CLS. 9, 16, 20, 25, 38, 41 AND 44.
- HEALTHCARE UNIFORM COMPANY, INC., ST. LOUIS, MO:
1,647,117. REN. 7-15-11. INT. CL. 42.
- HEARTHMARK, LLC, DALEVILLE, IN:
4,016,326. INT. CL. 4.
4,016,348. INT. CL. 34.
- HEAT AND CONTROL, INC., HAYWARD, CA:
2,462,410. REN. 7-18-11. INT. CL. 11.
- HEAVY HITTAS RECORDS, MANAGEMENT, PRODUCTION AND ENTERTAINMENT, INC., SOMERSET, NJ:
2,909,490. CANC. MULTIPLE CLASS, INT. CLS. 9, 35 AND 41.
- HED INTERNATIONAL INC., RINGOES, NJ:
929,575. REN. 7-20-11. U.S. CL. 34 (INT. CL. 11).
- HEDGESTREET, INC., SAN MATEO, CA:
2,911,577. CANC. MULTIPLE CLASS, INT. CLS. 16 AND 36.
- HEIM, COREY, WILMINGTON, NC:
4,016,020. PUB. 6-7-2011. INT. CL. 9.
- HEINEKEN BROUWERIJEN B.V., NETHERLANDS:
4,014,630. PUB. 6-7-2011. INT. CL. 32.
- HEINEKEN USA INCORPORATED, WHITE PLAINS, NY:
2,412,949. CANC. INT. CL. 32.
- HEINRICH AUGUST SCHOELLER SOHNE GMBH & CO. KG, 52355 DUREN, FED REP GERMANY:
2,474,242. REN. 7-17-11. INT. CL. 16.
- HELEN OF TROY LIMITED, ST. MICHAEL, BARBADOS:
2,528,434. REN. 7-19-11. INT. CL. 3.
- HELICOPTER FOUNDATION INTERNATIONAL, ALEXANDRIA, VA:
4,014,321. PUB. 6-7-2011. MULTIPLE CLASS, INT. CLS. 35, 36 AND 41.
- HELLENIC CABLES S.A., HELLENIC CABLE INDUSTRY S.A., ATHENS, GREECE:
2,909,387. CANC. INT. CL. 9.
- HELLENIC FINE OILS-IMPORT - EXPORT - TRADE AND FINANCIAL SERVICES S.A. - H.F.O., ATHENS, GREECE:
3,407,027. CANC. INT. CL. 29.
- HELMET HOUSE, INC., CALABASAS, CA:
1,166,616. REN. 7-19-11. INT. CL. 25.

HELMUT FISCHER GMBH INSTITUT FUR ELEKTRONIK UND MESSTECHNIK, SINDELFINGEN, FED REP GERMANY:
2,468,743. REN. 7-20-11. MULTIPLE CLASS, INT. CLS. 9, 41 AND 42.

HELP/SYSTEMS, LLC, EDAN PRAIRIE, MN:
2,910,689, CANC. INT. CL. 9.

HELSINN HEALTHCARE SA, SWITZERLAND:
4,014,458, PUB. 6-7-2011. MULTIPLE CLASS, INT. CLS. 9, 16 AND 41.

HEM CORPORATION PRIVATE LIMITED, MUMBAI, INDIA:
2,465,069. REN. 7-19-11. INT. CL. 3.

HENDRICK ASSOCIATES, INC., ATLANTA, GA:
2,582,322. REN. 7-15-11. INT. CL. 42.

HENDRICKSON USA, L.L.C. ITASCA, IL:
4,015,912, PUB. 6-7-2011. INT. CL. 12.

HENKEL AG & CO. KGAA, DUESSELDORF, FED REP GERMANY:
2,910,295, CANC. INT. CL. 3.

HENKEL CORPORATION, ROCKY HILL, CT:
2,412,892, CANC. INT. CL. 1.

HENRY BROCH & COMPANY, INC., GURNEE, IL:
4,015,931, PUB. 6-7-2011. INT. CL. 29.

HENRY R. ABEL & CO., LLC, MT. DESERT, ME:
2,911,002, CANC. INT. CL. 43.

HENRY, MATTHEW C. ORLANDO, FL:
2,910,958, CANC. INT. CL. 41.

HEP TECH CO., LTD., TAICHUNG CITY, TAIWAN:
4,016,521, MULTIPLE CLASS, INT. CLS. 9 AND 11.

HERAEUS KULZER GMBH, D-63450 HANAU, FED REP GERMANY:
2,412,124, CANC. INT. CL. 1.

HERBERT, WANDA, 75003, PARIS, FRANCE:
2,909,796, CANC. MULTIPLE CLASS, INT. CLS. 18 AND 25.

HERITAGE TECHNOLOGIES, LLC, INDIANAPOLIS, IN:
4,016,877, INT. CL. 5.

HERLAG HOLZWARENFABRIK GMBH & CO. KG, FED REP GERMANY:
4,014,667, PUB. 6-7-2011. MULTIPLE CLASS, INT. CLS. 12 AND 20.

HERMES INTERNATIONAL, 75008 PARIS, FRANCE:
4,015,306, PUB. 6-7-2011. INT. CL. 18.

HERNANDO MOSS, INC., HERNANDO, FL:
4,017,018, INT. CL. 21.

HERR HOLDINGS INC., WILMINGTON, DE:
4,014,670, PUB. 6-7-2011. INT. CL. 29.

HERREN, WILLIAM, SIMI VALLEY, CA AND HERREN, KATHLEEN, SIMI VALLEY, CA:
4,014,987, PUB. 6-7-2011. INT. CL. 37.

HERZIG EYE INSTITUTE INC., TORONTO, ONTARIO, CANADA:
2,909,396, CANC. INT. CL. 42.

HERZOG,GREG, RIDGEFIELD, CT, DBA HERZOG BODY TECH:
4,015,282, PUB. 6-7-2011. INT. CL. 41.

HEY NOW! ENTERTAINMENT L.L.C., FAIRLAWN, OH:
4,015,979, PUB. 6-7-2011. INT. CL. 35.

HEYL CHEMISCH-PHARMAZEUTISCHE FABRIK GMBH & CO. KG, BERLIN, FED REP GERMANY:
2,910,838, CANC. INT. CL. 5.

HH TECHNOLOGIES, INC., BREMEN, AL:
4,017,336, INT. CL. 19.

HICKERT, PAUL, BELLEAIR BLUFFS, FL:
2,911,764, CANC. INT. CL. 35.

HICKORY SPRINGS MANUFACTURING COMPANY, HICKORY, NC:
2,413,089, CANC. INT. CL. 17.

HIGH IMPACT TECHNOLOGY, TIGARD, OR:
4,016,225, INT. CL. 9.
4,016,243, INT. CL. 40.

HIGHGROVE PARTNERS, LLC, AUSTELL, GA:
4,015,237, PUB. 6-7-2011. MULTIPLE CLASS, INT. CLS. 37 AND 44.
4,015,238, PUB. 6-7-2011. MULTIPLE CLASS, INT. CLS. 37 AND 44.

HILDRETH, JOHN, DORR, MI:
4,015,653, PUB. 6-7-2011. INT. CL. 15.

HILEX POLY CO. LLC, HARTSVILLE, SC:
2,911,503, CANC. INT. CL. 16.

HILL-ROM SERVICES, INC., BATESVILLE, IN:
4,017,309, INT. CL. 10.

HILLYARD ENTERPRISES, INC., ST. JOSEPH, MO:
1,200,085. REN. 7-18-11. INT. CL. 3.
2,595,910. REN. 7-20-11. INT. CL. 5.

HILLYARD ENTERPRISES, INC., SAINT JOSEPH, MO:
4,016,760, INT. CL. 5.

HILTON KENNEDY COMPANY, LLC, LOUISVILLE, KY:
4,015,717, PUB. 6-7-2011. INT. CL. 37.

HINES, ANTHONY, WILSON, NC:
4,014,203, PUB. 6-7-2011. INT. CL. 25.

HIP-LIFE, ELIZABETH, NJ:
4,015,930, PUB. 6-7-2011. INT. CL. 25.

HIPERION CORPORATION, MIAMI, FL:
1,666,192. REN. 7-21-11. INT. CL. 42.

HITACHI SOLUTIONS, LTD., TOKYO 140-0002, JAPAN:
2,523,190. REN. 7-21-11. INT. CL. 9.

HITCHCOCK, DONALD, SAN CLEMENTE, CA:
4,017,162, INT. CL. 9.

HIX CORPORATION, PITTSBURG, KS:
2,911,237, CANC. INT. CL. 7.

HLT DOMESTIC IP LLC, MCLEAN, VA:
1,699,970. REN. 7-16-11. INT. CL. 42.

HMS LIFT INC., ST. GEORGE, ONTARIO, CANADA:
4,016,781, INT. CL. 12.

HMX POLAND SP.Z.O.O., LUXEMBOURG BRANCH, LUXEMBOURG, LUXEMBOURG:
2,911,809, CANC. INT. CL. 25.

HNI CORPORATION, MUSCATINE, IA:
2,470,129. REN. 7-15-11. INT. CL. 20.

HNI TECHNOLOGIES INC., MUSCATINE, IA:
2,413,267, CANC. INT. CL. 11.
2,911,526, CANC. INT. CL. 11.

HO-CHUNK NATION, BLACK RIVER FALLS, WI:
4,016,140, PUB. 6-7-2011. INT. CL. 41.
4,016,141, PUB. 6-7-2011. INT. CL. 41.

HOBBY LOBBY STORES, INC., OKLAHOMA CITY, OK:
4,017,292, INT. CL. 26.

HOECHST GMBH, FRANKFURT AM MAIN, FED REP GERMANY:
4,015,154, PUB. 6-7-2011. MULTIPLE CLASS, INT. CLS. 5 AND 10.

HOLCIM (US) INC., DUNDEE, MI:
2,911,690, CANC. INT. CL. 40.

HOLDEN SHEN, LLC, CHICAGO, IL:
4,017,116, INT. CL. 42.

HOLLINGSWORTH & VOSE COMPANY, EAST WALPOLE, MA:
2,455,385. REN. 7-20-11. INT. CL. 35.

HOLLYWOOD ENTERTAINMENT CORPORATION, WILSONVILLE, OR:
2,911,790, CANC. INT. CL. 41.

HOLLYWOOD FOTOFIX, INC., AMERICAN FORK, UT:
4,015,906, PUB. 6-7-2011. INT. CL. 41.

HOLOFIBER ENTERPRISES, INC., SANTA MONICA, CA:
2,587,070, COR. INT. CL. 25.

HOLOFIBER ENTERPRISES, INC., BEVERLY HILLS, CA:
3,021,383, COR. MULTIPLE CLASS, INT. CLS. 22, 23 AND 24.
3,055,878, COR. MULTIPLE CLASS, INT. CLS. 10 AND 24.

HOLY TERRA PRODUCTS, INC., PORTLAND, ME:
2,911,816, CANC. INT. CL. 5.

HOME BOX OFFICE, INC., NEW YORK, NY:
4,015,902, PUB. 6-7-2011. INT. CL. 41.

HOME PRODUCTS INTERNATIONAL - NORTH AMERICA, INC., CHICAGO, IL:
2,411,357. REN. 7-16-11. INT. CL. 21.

HOMEDIRECT, INC., HILLSIDE, IL:
4,016,787, INT. CL. 39.

HOMEFREE USA LLC, APPLETON, WI:
2,464,911. REN. 7-16-11. INT. CL. 36.

- HOMELAND VINYL PRODUCTS, INC., BIRMINGHAM, AL:
2,476,471. REN. 7-15-11. INT. CL. 19.
- HOMER TLC, INC., CLAYMONT, DE:
2,911,231, CANC. INT. CL. 11.
- HONDA GIKEN KOGYO KABUSHIKI KAISHA, MINATOKU, TOKYO 107, JAPAN:
1,682,371. REN. 7-20-11. INT. CL. 12.
- HONEYWELL INTERNATIONAL INC., MORRISTOWN, NJ:
4,016,882. INT. CL. 11.
- HONGSAMNARA CORP., RIDGEFIELD, NJ:
2,909,560, CANC. INT. CL. 30.
- HOOK ENTERTAINMENT, CALABASAS, CA:
4,015,640, PUB. 6-7-2011. INT. CL. 35.
- HOOZWARE, INC., FOSTER CITY, CA:
4,016,193, MULTIPLE CLASS, INT. CLS. 35 AND 45.
- HOP, RAFAEL COHEN, MEXICO CITY, MEXICO:
4,016,879, INT. CL. 25.
- HORN, SEAN PATRICK, COUNCIL BLUFFS, IA:
4,017,272, INT. CL. 25.
- HORSES4HEROES, INC., LAS VEGAS, NV:
4,014,699, PUB. 6-7-2011. INT. CL. 41.
- HORTECH, INC., SPRING LAKE, MI:
4,015,262, PUB. 6-7-2011. INT. CL. 31.
4,015,263, PUB. 6-7-2011. INT. CL. 31.
4,015,264, PUB. 6-7-2011. INT. CL. 31.
4,015,265, PUB. 6-7-2011. INT. CL. 31.
4,015,266, PUB. 6-7-2011. INT. CL. 31.
4,015,267, PUB. 6-7-2011. INT. CL. 31.
4,015,268, PUB. 6-7-2011. INT. CL. 31.
- HORTICULTURAL RESEARCH INSTITUTE, WASHINGTON, DC:
4,014,310, PUB. 6-7-2011. MULTIPLE CLASS, INT. CLS. 35, 36, 42 AND 44.
- HOSTESS BRANDS, INC., IRVING, TX, CONTINENTAL BAKING COMPANY, RYE, NY:
717,273. REN. 7-19-11. U.S. CL. 46 (INT. CL. 30).
- HOSTESS BRANDS, INC., IRVING, TX:
1,143,571, CANC. INT. CL. 30.
4,016,211, INT. CL. 30.
4,016,212, INT. CL. 30.
4,016,213, INT. CL. 30.
4,016,214, INT. CL. 30.
4,016,239, INT. CL. 30.
- HOT EDGE, INC., NEPONSET, IL:
4,016,534, INT. CL. 6.
- HOT ON YOUR TRAILER, INC., LOS ANGELES, CA:
2,910,579, CANC. INT. CL. 9.
- HOTARU, INC., BEVERLY HILLS, CA, DBA FIREFLY:
4,017,150, INT. CL. 41.
- HOTRON CO., LTD., TOKYO, JAPAN:
2,459,730. REN. 7-19-11. INT. CL. 9.
- HOTSPUR TECHNOLOGIES, INC., MOUNTAIN VIEW, CA:
4,016,965, INT. CL. 10.
- HOUPower WATCHES, LLC, SHAKER HEIGHTS, OH:
2,911,649, CANC. INT. CL. 14.
- HOUSE OF PRINCE A/S, DK-2860 SOBORG, DENMARK:
2,909,798, CANC. INT. CL. 34.
- HOUSE ON F STREET, LLC., THE, CLEVELAND, OH:
2,910,347, CANC. INT. CL. 16.
- HOUSEKEEPER, SHAN, IRVINE, KY:
2,911,280, CANC. INT. CL. 41.
- HOWARD, CECILIA, BEDFORD, NH:
4,016,922, INT. CL. 28.
- HOWI INC, YORKTOWN HEIGHTS, NY:
4,017,180, INT. CL. 3.
- HOYA CORPORATION, TOKYO, JAPAN:
4,017,137, INT. CL. 9.
- HPL, LLC, GILBERT, AZ:
4,016,953, INT. CL. 11.
- HR SOLUTIONS, INC., CHICAGO, IL:
4,015,412, PUB. 6-7-2011. INT. CL. 35.
- HS TM, LLC, NEWARK, DE:
2,463,659. REN. 7-20-11. INT. CL. 10.
4,015,209, PUB. 6-7-2011. INT. CL. 37.
- HUAMAO (XIAMEN) WEAVING; DYEING & FINISHING CO., LTD., XIAMEN, FUJIAN, CHINA:
4,014,456, PUB. 6-7-2011. MULTIPLE CLASS, INT. CLS. 22 AND 24.
- HUBB SYSTEMS, LLC, ALAMEDA, CA:
2,546,009. REN. 7-21-11. INT. CL. 9.
- HUBBELL INCORPORATED, SHELTON, CT:
2,457,733. REN. 7-18-11. INT. CL. 11.
- HUBMAR INTERNATIONAL INC., ST-LAURENT, CANADA:
4,017,279, INT. CL. 11.
- HUDSON GROUP (HG) RETAIL LLC, EAST RUTHERFORD, NJ:
4,017,115, INT. CL. 35.
- HUGHES, GABRIEL, LITCHFIELD PARK, AZ:
2,909,636, CANC. INT. CL. 28.
- HUGHLEY, JAY, LAPLACE, LA:
4,016,108, PUB. 6-7-2011. INT. CL. 25.
- HUGO BOSS TRADE MARKS MANAGEMENT GMBH & CO. KG, METZINGEN, FED REP GERMANY, AMBRA INC., NEW YORK, NY:
2,517,600. REN. 7-18-11. MULTIPLE CLASS, INT. CLS. 21, 24 AND 25.
- HULTON HOUSE CORPORATION, CLAWSON, MI:
4,015,623, PUB. 6-7-2011. INT. CL. 20.
- HUMANA INC., LOUISVILLE, KY:
4,017,005, INT. CL. 42.
- HUMANITY WITHOUT BORDERS FOUNDATION INC., NEW YORK, NY:
4,015,622, PUB. 6-7-2011. INT. CL. 45.
- HUMPHREYS, JAMES P, TUCSON, AZ:
2,911,760, CANC. INT. CL. 44.
- HUNT COMMUNICATIONS LLC, LIVINGSTON, NJ:
2,910,728, CANC. INT. CL. 41.
- HUNTER AND LOGAN JEWELRY LLC, SAN FRANCISCO, CA:
4,015,078, PUB. 6-7-2011. INT. CL. 14.
- HUNTER DOUGLAS INC., UPPER SADDLE RIVER, NJ:
4,016,991, INT. CL. 20.
- HUNTSMAN ETHYLENEAMINES LLC, THE WOODLANDS, TX:
2,497,221. REN. 7-17-11. INT. CL. 1.
- HURLEY INTERNATIONAL LLC, COSTA MESA, CA:
4,014,906, PUB. 6-7-2011. INT. CL. 25.
- HWA CHIN MACHINERY FACTORY CO., LTD., TAINAN HSIEN, TAIWAN:
2,412,219, CANC. INT. CL. 42.
- HYATT CORPORATION, CHICAGO, IL:
2,447,925. REN. 7-18-11. INT. CL. 36.
- HYBRID SILICA TECHNOLOGIES, INC., CAMBRIDGE, MA:
4,016,322, INT. CL. 1.
- HYCORR LLC, CLEVELAND, OH:
1,172,015. REN. 7-15-11. INT. CL. 7.
- HYD-SYSTEM TECHNOLOGY CO. LTD., IRVINE, CA:
4,015,814, PUB. 6-7-2011. INT. CL. 7.
- HYDRIA SPRINGS, INC., GREAT NECK, NY:
2,910,586, CANC. INT. CL. 35.
- HYPERTHERM, INC., HANOVER, NH:
2,425,143. REN. 7-21-11. INT. CL. 7.
- H2 VIDEO LIMITED, NICOSIA, CYPRUS:
2,909,962, CANC. INT. CL. 9.
2,909,963, CANC. INT. CL. 9.
- I AM AMERICA BOOKS, LLC, SCOTTSDALE, AZ:
4,016,762, INT. CL. 16.
- I NET CORP., ALEXANDRIA, VA:
2,900,109, CANC. INT. CL. 42.
- I-DEAL LLC, NEW YORK, NY:
2,911,068, CANC. INT. CL. 35.
- IAC INTERNATIONAL INCORPORATED, SHIGA-KEN, JAPAN:
2,911,417, CANC. INT. CL. 12.
- IAC SEARCH & MEDIA, INC., OAKLAND, CA:
2,463,252. REN. 7-21-11. INT. CL. 42.
- IAMMATTEO, MATTHEW, MORRISTOWN, NJ, TA MEDICAL DOCTOR:
4,017,307, INT. CL. 44.
- IAN GLADSTONE MCPHERSON PTY LTD, ELTHAM VICTORIA, AUSTRALIA:
4,014,997, PUB. 6-7-2011. INT. CL. 25.

IC PLUS CORPORATION, HSINCHU, TAIWAN:
2,476,530. REN. 7-18-11. INT. CL. 9.

ICON EYEWEAR, INC., SECAUCUS, NJ:
4,017,120. MULTIPLE CLASS, INT. CLS. 9 AND 28.

ICOR AB, UPPLANDS VASBY, SWEDEN:
2,411,772. CANC. INT. CL. 10.

ICUL SERVICE CORPORATION, NAPERVILLE, IL:
2,469,784. REN. 7-19-11. INT. CL. 36.

ICYNENE INC., MISSISSAUGA, ONTARIO, L4Z 1X2, CANADA:
2,411,675. CANC. MULTIPLE CLASS, INT. CLS. 35 AND 37.

ID ANALYTICS, INC., SAN DIEGO, CA:
4,016,226. INT. CL. 41.
4,016,227. INT. CL. 42.
4,016,228. INT. CL. 45.

IDEA INTERNATIONAL, INC., LAS VEGAS, NV:
4,014,750. PUB. 6-7-2011. INT. CL. 9.

IDEA NUOVA, INC., NEW YORK, NY:
4,016,468. INT. CL. 24.

IDENT-A-KID SERVICES OF AMERICA, INC., ST. PETERSBURG, FL:
4,017,402. INT. CL. 45.

IDOC, LLC, NORWALK, CT:
4,015,398. PUB. 6-7-2011. INT. CL. 41.

IDT NETHERLANDS. B.V. (PUERTO RICO BRANCH), SAN JUAN, PUERTO RICO:
2,910,787. CANC. INT. CL. 36.

IDX CORPORATION, ST. LOUIS, MO:
2,523,358. REN. 7-15-11. INT. CL. 20.

IF&P FOODS, INC., INDIANAPOLIS, IN:
4,014,360. PUB. 6-7-2011. INT. CL. 35.

IGT, RENO, NV:
2,910,821. CANC. INT. CL. 9.
4,016,409. INT. CL. 9.

IHOP IP, LLC, GLENDALE, CA:
4,015,959. PUB. 6-7-2011. INT. CL. 32.

IKANOS COMMUNICATIONS, INC., FREMONT, CA:
4,015,534. PUB. 6-7-2011. INT. CL. 9.

IKASYSTEMS, SOUTHBOROUGH, MA:
4,017,382. MULTIPLE CLASS, INT. CLS. 35, 38 AND 42.

ILIUS, BOULOGNE BILLANCOURT, FRANCE:
2,910,274. CANC. MULTIPLE CLASS, INT. CLS. 9, 16, 38, 39, 41 AND 45.

ILLIG, DAVID P., PORTLAND, OR:
2,472,951. REN. 7-20-11. INT. CL. 9.

ILLINOIS TOOL WORKS INC., GLENVIEW, IL:
2,411,643. CANC. INT. CL. 6.
2,472,695. REN. 7-18-11. MULTIPLE CLASS, INT. CLS. 6, 7 AND 42.
2,910,605. CANC. INT. CL. 1.
2,911,781. CANC. INT. CL. 9.
4,016,646. INT. CL. 6.

ILONA, INC., DENVER, CO:
4,016,237. INT. CL. 3.

IMAGE-I-NATION TECHNOLOGIES, INC., MONROE, NC, DBA IMAGINATION TECHNOLOGIES:
4,014,409. PUB. 6-7-2011. INT. CL. 9.

IMAGEMOVERS, L.L.C., BEVERLY HILLS, CA:
2,439,569. REN. 7-21-11. INT. CL. 41.
2,460,528. REN. 7-21-11. INT. CL. 41.

IMAGINATION MOVERS, NEW ORLEANS, LA:
2,909,765. CANC. INT. CL. 41.

IMAGINE APPAREL GROUP, L.L.C., NEW YORK, NY:
4,016,152. MULTIPLE CLASS, INT. CLS. 9, 18 AND 25.

IMAGINE ENERGY, LLC, PORTLAND, OR:
4,015,297. PUB. 6-7-2011. INT. CL. 35.

IMGRP, INC., DALLAS, TX:
2,909,676. CANC. INT. CL. 35.

IMMUNEX CORPORATION, SEATTLE, WA:
2,412,992. CANC. INT. CL. 42.

IMPACT TEEN DRIVERS FUND, SACRAMENTO, CA:
4,015,518. PUB. 6-7-2011. INT. CL. 35.

IMPACT60 LEARNING SYSTEMS, LLC, STERLING, VA:
4,017,252. INT. CL. 41.
4,017,253. INT. CL. 41.

IMPERIAL CHEMICAL INDUSTRIES PLC, LONDON, ENGLAND:
2,909,455. CANC. MULTIPLE CLASS, INT. CLS. 1, 2, 3, 4, 5, 7, 9, 11, 16, 17, 19, 29, 30, 35, 36, 37, 39, 40, 41 AND 42.

IMS MESSSYSTEME GMBH, HEILIGENHAUS, FED REP GERMANY:
2,964,515. CANC. MULTIPLE CLASS, INT. CLS. 37 AND 42.

IMS SOFTWARE SERVICES, LTD., WILMINGTON, DE:
2,910,281. CANC. MULTIPLE CLASS, INT. CLS. 9, 16, 35 AND 44.

INDELIBLE MARKS, LLC, MURRELLS INLET, SC:
4,015,626. PUB. 6-7-2011. INT. CL. 25.

INDEPENDENCE TELEVISION CO., INC., LOUISVILLE, KY:
4,015,362. PUB. 6-7-2011. INT. CL. 42.
4,015,364. PUB. 6-7-2011. INT. CL. 42.
4,015,365. PUB. 6-7-2011. INT. CL. 41.

INDEPENDENT HEALTH ASSOCIATION, INC., BUFFALO, NY:
2,911,424. CANC. INT. CL. 36.

INDEPENDENT RESEARCH GROUP LLC, NEW YORK, NY:
2,910,476. CANC. INT. CL. 36.

INDEVR, INC., BOULDER, CO:
4,015,460. PUB. 6-7-2011. MULTIPLE CLASS, INT. CLS. 1 AND 9.

INDIANA RIGHT TO LIFE, INC., EVANSVILLE, IN:
2,910,101. CANC. INT. CL. 16.

INDIANA WHOLESALE DEALERS INC., HAMMOND, IN:
4,017,421. INT. CL. 36.

INDIEFLIX, INC., SEATTLE, WA:
4,015,544. PUB. 6-7-2011. INT. CL. 35.

INDUSTRIAL COMMERCIAL SCALES, LLC, NORTH CHARLESTON, SC:
4,015,333. PUB. 6-7-2011. INT. CL. 9.

INDUSTRIAL E COMERCIAL F. PERNANBUCO LTDA., PATOS DE MINAS, GERAIS, 38706-706, BRAZIL:
2,910,771. CANC. INT. CL. 33.

INDUSTRIAL LA FAMA, S.A. DE C.V., MORELIA, MICH., MEXICO:
4,014,846. PUB. 6-7-2011. INT. CL. 3.

INDUSTRIAL RIVET & FASTENER CO., NORTHVALE, NJ:
4,017,222. MULTIPLE CLASS, INT. CLS. 6, 7 AND 8.

INDUSTRIAL TOOLS, INC., OXNARD, CA:
2,492,718. REN. 7-18-11. INT. CL. 7.

INDUSTRIAS ALEN, S.A. DE C.V., N.L., MEXICO:
4,016,091. PUB. 6-7-2011. INT. CL. 3.

INDUSTRIAS T.TAIO, LOS ANGELES, CA:
4,016,974. MULTIPLE CLASS, INT. CLS. 3 AND 21.

INERGY AUTOMOTIVE SYSTEMS, F-75009 PARIS, FRANCE:
2,909,682. CANC. MULTIPLE CLASS, INT. CLS. 7, 9, 12 AND 17.

INFANT CREATIONS, INC., SAPULPA, OK:
2,910,225. CANC. INT. CL. 20.

INFANTINO, LLC, SAN DIEGO, CA:
4,016,531. INT. CL. 18.

INFORMATION TECHNOLOGY AND INVENTOR SERVICES LLC, MOUNT LAUREL, NJ:
4,014,730. PUB. 6-7-2011. INT. CL. 37.

INFRARED DYNAMICS, INC., YORBA LINDA, CA:
2,572,237. REN. 7-15-11. INT. CL. 11.

INFUSION MANAGEMENT GROUP, INC., CHICAGO, IL:
4,015,527. PUB. 6-7-2011. INT. CL. 43.

ING, GEORGE, HOOD RIVER, OR, DBA ING ORCHARDS:
2,911,726. CANC. INT. CL. 31.

INGEAR CORPORATION, BUFFALO GROVE, IL:
2,910,128. CANC. INT. CL. 21.

INGENIX, INC., EDEN PRAIRIE, MN:
2,911,051. CANC. INT. CL. 35.
4,014,980. PUB. 6-7-2011. INT. CL. 42.

INGENUS PHARMACEUTICALS, LLC, ORLANDO, FL:
4,016,654. INT. CL. 5.

INGEUS LIMITED, BRISBANE 4000, QUEENSLAND, AUSTRALIA:
2,910,272. CANC. MULTIPLE CLASS, INT. CLS. 35 AND

41.
INGO MAURER GMBH, 80801 MUNICH, FED REP GERMANY:
2,469,254. REN. 7-15-11. INT. CL. 11.
- INIX PRODUCTS, CORP., SAN MARCOS, TX:
4,015,499. PUB. 6-7-2011. INT. CL. 20.
- INIZIO ENTERTAINMENT, LLC, ST CHARLES, IL:
4,016,912. MULTIPLE CLASS, INT. CLS. 9, 25 AND 41.
- INJURED WORKERS PHARMACY, LLC, METHUEN, MA:
3,980,741. AM. INT. CL. 35.
- INNER CIRCLE DESIGNS, LLC, MARIETTA, GA:
4,016,093. PUB. 6-7-2011. INT. CL. 14.
4,016,094. PUB. 6-7-2011. INT. CL. 14.
- INNOVATIVE AUTOMATION, INC., CARROLLTON, TX:
4,015,091. PUB. 6-7-2011. INT. CL. 35.
- INNOVATIVE IDEAS INTERNATIONAL, LTD., LAS VEGAS, NV:
2,910,503. CANC. INT. CL. 35.
- INNOVATIVE LIGHTING INC., ROLAND, IA:
4,017,310. INT. CL. 9.
- INNOVENTIONS INC., HOUSTON, TX:
4,015,442. PUB. 6-7-2011. INT. CL. 42.
- INNOVET ITALIA S.R.L. 20144 MILANO, ITALY:
3,070,074. CANC. INT. CL. 31.
- INO-PRODUCTS, INC., TORONTO, CANADA:
4,016,410. INT. CL. 12.
- INOUE, REID, HONOLULU, HI:
4,017,376. MULTIPLE CLASS, INT. CLS. 16 AND 25.
- INPECO SA, CH-6900 LUGANO, SWITZERLAND:
4,014,488. PUB. 6-7-2011. MULTIPLE CLASS, INT. CLS. 7, 9 AND 10.
- INSHORE ANGLER CHARTERS, INC., FORT WALTON BEACH, FL, DBA INSHORE ANGLER:
4,015,284. PUB. 6-7-2011. INT. CL. 25.
- INSIGHT PARTNERS INC., BOSTON, MA:
2,910,769. CANC. MULTIPLE CLASS, INT. CLS. 41 AND 42.
- INSTITUTE FOR SAFE MEDICATION PRACTICES, HORSHAM, PA:
2,525,380. REN. 7-19-11. INT. CL. 35.
- INSTITUTE FOR STRATEGIC CHANGE, CARLSBAD, CA:
4,014,293. PUB. 6-7-2011. MULTIPLE CLASS, INT. CLS. 14 AND 16.
- INSTITUTE OF INTELLECTUAL PROPERTY AND SOCIAL JUSTICE, INC., COLUMBIA, MD, AKA IIPSI, INC.:
4,017,319. INT. CL. 41.
4,017,320. INT. CL. 35.
- INSURMARK, INC., HOUSTON, TX:
4,015,494. PUB. 6-7-2011. INT. CL. 41.
- INSWEB CORPORATION, RANCHO CORDOVA, CA:
2,910,387. CANC. INT. CL. 36.
- INTACCT CORPORATION, SAN JOSE, CA:
2,470,412. REN. 7-20-11. MULTIPLE CLASS, INT. CLS. 35 AND 39.
- INTEGRA ADHESIVES INC., ABBOTSFORD, BC, CANADA:
4,014,402. PUB. 6-7-2011. INT. CL. 1.
- INTEGRATED BRANDS, INC., RONKONKOMA, NY:
1,253,994. CANC. INT. CL. 42.
- INTEGRATED CHINESE MEDICINE HOLDINGS, LTD., TST EAST KOWLOON, HONG KONG:
2,911,407. CANC. INT. CL. 5.
- INTEGRATION ASSOCIATES INC., MOUNTAIN VIEW, CA:
2,909,917. CANC. INT. CL. 9.
- INTEGREON, INC., ROAD TOWN, TORTOLA, BR. VIRGIN ISLANDS:
4,014,947. PUB. 6-7-2011. INT. CL. 39.
4,014,948. PUB. 6-7-2011. INT. CL. 39.
- INTEGRITY DELAWARE, LLC, HOUSTON, TX:
2,466,929. REN. 7-20-11. INT. CL. 3.
- INTEL CORPORATION, SANTA CLARA, CA:
2,911,320. CANC. INT. CL. 9.
- INTELLIDYN CORP., BETHPAGE, NY:
2,910,090. CANC. MULTIPLE CLASS, INT. CLS. 38 AND 42.
2,910,092. CANC. INT. CL. 35.
- INTELLIGENT BIOCIDES, LLC, TYNGSBOROUGH, MA:
2,418,016. REN. 7-19-11. INT. CL. 1.
- INTELLIGENT BIOCIDES, LLC, TEWKSBURY, MA:
2,418,016. COR. INT. CL. 1.
- INTELLIGENT DEVICES INC., ST. PETER, BARBADOS:
2,911,597. CANC. INT. CL. 9.
- INTELLIGENT MARKETING SOLUTIONS, INC., PURCHASE, NY:
4,016,310. INT. CL. 41.
- INTELLIGENT MEDICAL OBJECTS, INC., NORTHBROOK, IL:
4,016,441. INT. CL. 42.
- INTELLIGENT MUSIC ENTERTAINMENT, INC., NEW YORK, NY:
4,015,546. PUB. 6-7-2011. INT. CL. 41.
- INTERACTIVE INTELLIGENCE, INC., INDIANAPOLIS, IN:
2,535,011. REN. 7-15-11. INT. CL. 9.
- INTERAGES, INC., KENSINGTON, MD:
1,743,759. COR. INT. CL. 42.
- INTERCOSMA WEST S.P.A., GENOVA, ITALY:
1,627,859. CANC. MULTIPLE CLASS, INT. CLS. 3, 16 AND 18.
- INTEREX CORP., IRVING, TX:
4,016,121. PUB. 6-7-2011. INT. CL. 30.
4,016,122. PUB. 6-7-2011. INT. CL. 30.
4,016,123. PUB. 6-7-2011. INT. CL. 30.
- INTERFACE, INC., ATLANTA, GA:
4,016,868. INT. CL. 27.
- INTERNATIONAL ACTUARIAL ASSOCIATION / ASSOCIATION ACTUARIELLE INTERNATIONALE, ONTARIO, CANADA:
4,016,501. INT. CL. 36.
- INTERNATIONAL BUSINESS MACHINES CORP, ARMONK, NY:
4,017,276. MULTIPLE CLASS, INT. CLS. 9, 16 AND 42.
- INTERNATIONAL BUSINESS MACHINES CORPORATION, ARMONK, NY:
1,789,241. CANC. MULTIPLE CLASS, INT. CLS. 9 AND 16.
- INTERNATIONAL BUSINESS MACHINES, INC., ARMONK, NY:
1,606,840. REN. 7-16-11. INT. CL. 42.
- INTERNATIONAL BUSINESS SYSTEMS, INC., KING OF PRUSSIA, PA:
2,910,514. CANC. MULTIPLE CLASS, INT. CLS. 35 AND 40.
- INTERNATIONAL CONSTRUCTION PRODUCTS RESEARCH, INC., FAIRFIELD, CT:
4,015,904. PUB. 6-7-2011. INT. CL. 19.
- INTERNATIONAL DATA GROUP, INC., FRAMINGHAM, MA:
2,983,193. CANC. MULTIPLE CLASS, INT. CLS. 16 AND 42.
4,017,359. INT. CL. 35.
- INTERNATIONAL E-Z UP, INC., RIVERSIDE, CA:
2,455,538. REN. 7-20-11. INT. CL. 22.
2,457,377. REN. 7-19-11. INT. CL. 22.
- INTERNATIONAL FASHIONS, LTD., VANCOUVER, CANADA:
4,016,675. INT. CL. 25.
- INTERNATIONAL FIRE SPRINKLER, INC., ST. LOUIS, MO:
2,909,601. CANC. INT. CL. 42.
- INTERNATIONAL FRUIT GENETICS, LLC, BAKERSFIELD, CA:
4,016,806. INT. CL. 31.
- INTERNATIONAL LUBRICANTS, INC., SEATTLE, WA:
4,014,776. PUB. 6-7-2011. MULTIPLE CLASS, INT. CLS. 1 AND 4.
- INTERNATIONAL MANUFACTURING GROUP, INC., WEST SACRAMENTO, CA:
2,412,960. CANC. INT. CL. 21.
- INTERNATIONAL PAPER COMPANY, MEMPHIS, TN, 6400 POPLAR AVENUE:
2,412,890. CANC. INT. CL. 16.
- INTERNATIONAL PLAYTHINGS LLC, PARSIPPANY, NJ:
2,910,905. CANC. INT. CL. 28.
- INTERNATIONAL PRODUCTS GROUP, SOUTH JORDAN, UT:
4,016,148. INT. CL. 3.

- INTERNATIONAL RESTAURANT MANAGEMENT GROUP, CORAL GABLES, FL:
2,587,843. REN. 7-19-11. INT. CL. 42.
- INTERNATIONAL SKATING UNION, CH 1007 LAUSANNE, SWITZERLAND:
2,474,864. REN. 7-19-11. INT. CL. 41.
2,477,073. REN. 7-19-11. INT. CL. 41.
- INTERNATIONAL SWAMINARAYAN SATSANG ORGANIZATION (I.S.S.O.) OF CHICAGO, WHEELING, IL:
2,411,681, CANC. MULTIPLE CLASS, INT. CLS. 41 AND 42.
- INTERNATIONAL TRADEMARKS APPAREL INC., TORONTO, ONTARIO, M6B 1P5, CANADA:
2,412,814, CANC. MULTIPLE CLASS, INT. CLS. 9 AND 25.
- INTERSTATE INDUSTRIES, INC., LOVINGSTON, VA:
4,016,154, INT. CL. 9.
4,016,155, INT. CL. 9.
4,016,156, INT. CL. 9.
4,016,157, INT. CL. 9.
- INTERTAINER, INC., CULVER CITY, CA:
2,909,417, CANC. INT. CL. 38.
- INTERVET INC., SUMMIT, NJ:
2,435,287. REN. 7-15-11. INT. CL. 42.
- INTERWORKING LABS, INC., SCOTTS VALLEY, CA:
4,014,966, PUB. 6-7-2011. INT. CL. 9.
- INTRADIN (SHANGHAI) MACHINERY CO., LTD., CHINA:
4,014,516, PUB. 6-7-2011. MULTIPLE CLASS, INT. CLS. 7 AND 9.
- INVENTIO AG, SWITZERLAND:
4,014,628, PUB. 6-7-2011. MULTIPLE CLASS, INT. CLS. 9, 35, 38 AND 45.
- INVENTION TECHNOLOGIES, INC., CORAL GABLES, FL:
2,911,252, CANC. INT. CL. 42.
2,911,254, CANC. INT. CL. 42.
- INVENTIV COMMUNICATIONS, INC., WESTERVILLE, OH:
2,909,870, CANC. INT. CL. 35.
- INVIVO RESEARCH INC., ORLANDO, FL:
2,910,398, CANC. INT. CL. 10.
- IN2VATE, L.L.C., TULSA, OK:
2,413,292, CANC. INT. CL. 16.
- IOFINA NATURAL GAS, INC., GREENWOOD VILLAGE, CO:
4,017,291, INT. CL. 5.
- IPEK SPEZIAL-TV GESMBH & CO. KG, AUSTRIA:
4,014,448, PUB. 6-7-2011. INT. CL. 9.
- IPO FINANCIAL NETWORK CORP., MILBURN, NJ:
2,412,841, CANC. INT. CL. 16.
- IPSEN INTERNATIONAL GMBH, KLEVE, FED REP GERMANY:
2,910,357, CANC. MULTIPLE CLASS, INT. CLS. 9 AND 42.
- IPSEN PHARMA S.A.S., BOULOGNE-BILLANCOURT, FRANCE:
2,910,344, CANC. MULTIPLE CLASS, INT. CLS. 5, 9 AND 42.
- IRISH DISTILLERS LIMITED, BALLSBRIDGE, DUBLIN 4, IRELAND, TA JOHN POWER & SON, TA JOHN JAMESON & SON, TA CORK DISTILLERIES COMPANY AND TA HUZAR VODKA COMPANY:
1,656,412. REN. 7-16-11. INT. CL. 33.
- IRN, INC., GRAND RAPIDS, MI:
2,475,243. REN. 7-18-11. MULTIPLE CLASS, INT. CLS. 16 AND 35.
- IRON DEMONS MC, EDISON, NJ:
4,015,591, PUB. 6-7-2011. INT. CL. 41.
- IRONCO ENTERPRISES, LLC, PHOENIX, AZ:
2,911,156, CANC. INT. CL. 40.
- IRONWOOD CAPITAL LTD., AVON, CT:
2,509,356. REN. 7-16-11. INT. CL. 36.
- IRONWOOD PHARMACEUTICALS, INC., CAMBRIDGE, MA:
4,016,216, INT. CL. 5.
- ISACO INTERNATIONAL CORPORATION, MIAMI LAKES, FL:
4,016,146, INT. CL. 25.
- ISCRROLL INC, ROCKVILLE, MD:
4,017,343, INT. CL. 9.
- ISHA FOUNDATION, INC., MCMINNVILLE, TN:
4,014,381, PUB. 6-7-2011. MULTIPLE CLASS, INT. CLS. 35 AND 41.
- ISI BRANDS, INC., GRAND RAPIDS, MI:
4,016,187, INT. CL. 5.
- ISMAN J CORPORATION, KANAGAWA 210-0855, JAPAN:
4,014,609, PUB. 6-7-2011. MULTIPLE CLASS, INT. CLS. 6, 7 AND 12.
- ISPA, INC., ATLANTA, GA:
4,014,913, PUB. 6-7-2011. INT. CL. 9.
- IT OUTLET, INC., SIOUX FALLS, SD:
4,017,274, INT. CL. 37.
- ITELLIGENCE AG, FED REP GERMANY:
4,014,521, PUB. 6-7-2011. MULTIPLE CLASS, INT. CLS. 9, 35 AND 42.
- ITT ENIDINE INC., ORCHARD PARK, NY:
2,405,943. REN. 7-20-11. MULTIPLE CLASS, INT. CLS. 7 AND 9.
- ITW CCIP HOLDINGS LLC, WILMINGTON, DE:
2,525,808, CANC. INT. CL. 12.
- IVILLAGE PARENTING NETWORK, INC., NEW YORK, NY:
2,411,791, CANC. INT. CL. 41.
- IVY BEAUTY CORPORATION SDN. BHD., KUALA LUMPUR, MALAYSIA:
4,016,560, INT. CL. 3.
- I2K HOLDINGS, INC., SAN FRANCISCO, CA:
2,910,255, CANC. MULTIPLE CLASS, INT. CLS. 9, 35, 36, 41 AND 42.
- J. MOONEY INC., HUNTSVILLE, TX:
4,015,542, PUB. 6-7-2011. INT. CL. 37.
- J. SCHMALZ GMBH, D-72293 GLATTEN, FED REP GERMANY:
2,487,861. REN. 7-15-11. MULTIPLE CLASS, INT. CLS. 7, 9 AND 17.
- J. STRICKLAND & CO., OLIVE BRANCH, MS, PLOUGH CHEMICAL COMPANY, MEMPHIS, TN:
148,723. REN. 7-18-11. U.S. CL. 6 (INT. CL. 3).
- J.D.W. INVESTMENTS, INC., PLANO, TX:
2,910,984, CANC. INT. CL. 37.
- J.K. ANSELL LIMITED, AURANGIBAD 431 136, INDIA TO J.K. ANSELL LIMITED, AURANGIBAD 431 136, INDIA:
2,412,758, CANC. INT. CL. 10.
- J.P. WISER'S DISTILLERY LIMITED, TORONTO, ONTARIO, CANADA:
4,015,051, PUB. 6-7-2011. INT. CL. 33.
- JACARA LLC, SEWARD, AK, DBA JACARA THERAPEUTIC SKIN CARE:
4,015,415, PUB. 6-7-2011. INT. CL. 3.
- JACK DANIEL'S PROPERTIES, INC, SAN RAFAEL, CA, JACK DANIEL DISTILLERY, LEM MOTLOW, PROP., INC., LYNCHBURG, TN:
444,537. REN. 7-18-11. U.S. CL. 49 (INT. CL. 33).
- JACKIE SQUARED, INC., JACKSONVILLE BEACH, FL:
3,788,368, COR. INT. CL. 41.
- JACKSON HOLE MOUNTAIN RESORT CORPORATION, TETON VILLAGE, WY:
4,017,010, INT. CL. 41.
- JACKSON, B R D C, GALLATIN, TN, DBA CHIROVET-PRACTIC:
2,911,487, CANC. INT. CL. 44.
- JACO ENTERPRISES, INC., PHOENIX, AZ:
4,016,532, INT. CL. 9.
- JACOBOSKI, ROBERT BRYAN, MCLEAN, VA:
2,412,292, CANC. INT. CL. 36.
- JACOBS WIND ELECTRIC COMPANY, INC., CORCORAN, MN:
1,532,714, CANC. INT. CL. 7.
- JACOBSON, BETTY, VIRGINIA BEACH, VA AND JACOBSON, SUZANNE, VIRGINIA BEACH, VA:
2,908,306, CANC. INT. CL. 16.
- JAKOV, AVI, ENCINO, CA:
2,909,976, CANC. INT. CL. 25.
- JAMAK FABRICATION-TEX, LLC, FORT WORTH, TX, M MANAGEMENT-TEX, LTD., FORT WORTH, TX:
2,532,461. REN. 7-20-11. INT. CL. 3.
- JAMES A. PARKER, OAK PARK, IL:
4,016,556, MULTIPLE CLASS, INT. CLS. 35, 38, 41, 42

- AND 45.
 JAMES H. WATERS III, WILMINGTON, NC:
 4,014,843, PUB. 6-7-2011. INT. CL. 25.
 JAMES J. RIZZI, INC., NEW YORK, NY:
 3,789,888, COR. MULTIPLE CLASS, INT. CLS. 11, 16, 18,
 21, 26, 28 AND 34.
 JAMES, JELANI, PEARLAND, TX:
 4,015,758, PUB. 6-7-2011. INT. CL. 25.
 JANE ELIZABETH PUBLISHING, INC., LOUISVILLE, KY:
 4,017,028, INT. CL. 16.
 JANN LORI, LLC, WEST MILFORD, NJ:
 4,015,607, PUB. 6-7-2011. INT. CL. 25.
 JAPAN UNIX CO., LTD., MINATO-KU, TOKYO, JAPAN:
 4,014,216, PUB. 6-7-2011. INT. CL. 7.
 JARDEN CORPORATION, RYE, NY:
 2,909,541, CANC. INT. CL. 8.
 JARED FLOOD, LLC, JERSEY CITY, NJ, DBA BROOKLYN
 TWEED:
 4,017,387, MULTIPLE CLASS, INT. CLS. 16, 23 AND 25.
 JARMAN-JOHNSON COMMUNICATIONS, INC., GRAND
 RAPIDS, MI:
 2,911,628, CANC. INT. CL. 35.
 JARRITOS, INC., EL PASO, TX:
 4,014,405, PUB. 6-7-2011. INT. CL. 32.
 JASON ENTERPRISES, INC., OWINGS, MD:
 2,910,008, CANC. INT. CL. 5.
 JASON ISHERWOOD, AUSTRALIA:
 4,014,475, PUB. 6-7-2011. MULTIPLE CLASS, INT. CLS.
 16, 35, 36 AND 37.
 JASON KATIMS, NEW YORK, NY:
 4,016,674, MULTIPLE CLASS, INT. CLS. 38 AND 41.
 JAY KAMHI, LARGO, FL AND GAYLE MIDDLETON,
 LARGO, FL:
 4,015,637, PUB. 6-7-2011. INT. CL. 28.
 JC AB, SWEDEN:
 4,014,589, PUB. 6-7-2011. MULTIPLE CLASS, INT. CLS. 18
 AND 25.
 JC ENTERTAINMENT LIGHTING SERVICES, INC., SUN
 VALLEY, CA:
 4,016,149, MULTIPLE CLASS, INT. CLS. 35, 37, 40, 41, 42
 AND 45.
 JC MARKETING, INC., WALNUT, CA:
 2,500,824, REN. 7-20-11. INT. CL. 30.
 JCL PRODUCTIONS INC., LINCOLN, NE:
 4,015,488, PUB. 6-7-2011. INT. CL. 16.
 JCW ENTERPRISES, INC., NEW YORK, NY:
 4,016,292, INT. CL. 45.
 JDA SOFTWARE GROUP, INC., SCOTTSDALE, AZ:
 2,909,710, CANC. INT. CL. 9.
 JEAN PHILIPPE FRAGRANCES, L.L.C., NEW YORK, NY:
 1,646,463, REN. 7-19-11. INT. CL. 3.
 JEFFREY N. MAR, M.D., INC., SAN BERNARDINO, CA:
 4,015,000, PUB. 6-7-2011. INT. CL. 44.
 4,015,003, PUB. 6-7-2011. INT. CL. 44.
 JEFFREY SORRELL, SACHSE, TX:
 4,017,394, INT. CL. 37.
 JEMA CORPORATION, TACOMA, WA:
 2,910,133, CANC. INT. CL. 9.
 JENETT, MARILYN, LOS ANGELES, CA:
 4,015,335, PUB. 6-7-2011. INT. CL. 41.
 JENTEK SENSORS, INC., WALTHAM, MA:
 4,014,294, PUB. 6-23-2009. INT. CL. 9.
 JESAGA, LLC, SAN FRANCISCO, CA:
 4,015,339, PUB. 6-7-2011. INT. CL. 36.
 JESSTEVEAND, INC., JOPLIN, MO:
 4,014,307, PUB. 6-7-2011. INT. CL. 31.
 JEWELRY BY DANIELE TRISSI, LTD., SCARSDALE, NY:
 2,909,872, CANC. MULTIPLE CLASS, INT. CLS. 14 AND
 35.
 JIANGSU YIXING FINE POTTERY CORP., LTD, CHINA:
 4,014,575, PUB. 6-7-2011. INT. CL. 21.
 JIFFY INTERNATIONAL AS, KRISTIANSAND, NORWAY:
 4,016,821, INT. CL. 1.
 JIM BALL, INC., DESTIN, FL:
 2,909,373, CANC. INT. CL. 35.
 JIMMY HACK GOLF, LLC, EASLEY, SC:
 4,015,028, PUB. 6-7-2011. INT. CL. 28.
 JIMMYS WOOL, LLC, RENO, NV, DBA JIMMY BEANS
 WOOL:
 4,017,378, INT. CL. 35.
 JJI LIGHTING GROUP, INC., FRANKLIN PARK, CT:
 2,413,181, CANC. INT. CL. 11.
 JK DESIGN, HILLSBOROUGH, NJ:
 4,015,112, PUB. 6-7-2011. INT. CL. 35.
 JOBLEADERS, INC., ENCINITAS, CA:
 2,509,640, REN. 7-15-11. INT. CL. 16.
 JOERNS HEALTHCARE, LLC, STEVENS POINT, WI:
 4,016,513, INT. CL. 10.
 JOEY AND T, LLC, LOS ANGELES, CA:
 2,910,045, CANC. INT. CL. 25.
 JOEY BAG A DONUTS LLC, MOUNT PLEASANT, SC:
 4,015,203, PUB. 6-7-2011. INT. CL. 43.
 JOHN A. SMITH, NEW ORLEANS, LA, DBA UMOJA
 VISIONS:
 4,015,458, PUB. 6-7-2011. INT. CL. 3.
 JOHN B. STETSON CO., HOBOKEN, NJ:
 1,154,964, REN. 7-19-11. INT. CL. 26.
 JOHN B. STETSON COMPANY, HOBOKEN, NJ:
 143,184, REN. 7-19-11. U.S. CL. 39 (INT. CL. 25).
 JOHN M. CAMPBELL CONSULTING, LLC, NORMAN, OK:
 4,017,079, INT. CL. 42.
 JOHN PRYOR, OMAHA, NE:
 4,015,952, PUB. 6-7-2011. INT. CL. 25.
 JOHN S. PIRRETTI, PALM COAST, FL:
 4,015,420, PUB. 6-7-2011. INT. CL. 28.
 JOHN SCHOLTES INVESTMENTS (NO 1) PTY LTD, AUS-
 TRALIA:
 4,014,625, PUB. 6-7-2011. INT. CL. 6.
 JOHN ZINK COMPANY, L.L.C., TULSA, OK:
 2,473,311, REN. 7-15-11. MULTIPLE CLASS, INT. CLS. 11,
 37, 40 AND 42.
 JOHNSON & JOHNSON, NEW BRUNSWICK, NJ:
 2,911,394, CANC. INT. CL. 5.
 4,014,837, PUB. 6-7-2011. INT. CL. 35.
 4,014,838, PUB. 6-7-2011. INT. CL. 35.
 4,016,450, MULTIPLE CLASS, INT. CLS. 35 AND 41.
 4,016,839, MULTIPLE CLASS, INT. CLS. 3 AND 5.
 JOHNSON ELECTRIC INDUSTRIAL MANUFACTORY
 LIMITED, NEW TERRITORIES, HONG KONG:
 2,909,606, CANC. MULTIPLE CLASS, INT. CLS. 35, 40
 AND 42.
 JOHNSON OIL COMPANY, GONZALES, TX:
 4,015,785, PUB. 6-7-2011. INT. CL. 4.
 JOHNSON, MONA, SALISBURY, MA AND JOHNSON,
 TIMOTHY, SALISBURY, MA:
 4,016,565, INT. CL. 25.
 JOHNSON, STEVEN, GLADWIN, MI:
 4,016,262, INT. CL. 41.
 JOHNSON, TARA, BROOKLYN, NY:
 4,016,523, INT. CL. 4.
 JOINGO LLC, SAN JOSE, CA:
 4,017,097, INT. CL. 42.
 JOINT COMMISSION ON ACCREDITATION OF HEALTH-
 CARE ORGANIZATIONS, OAK BROOK TERRACE, IL,
 JOINT COMMISSION ON ACCREDITATION OF HOSPI-
 TALS, CHICAGO, IL:
 910,240, REN. 7-19-11. U.S. CL. 100 (INT. CL. 42).
 JONAS WHITE CATERING LLC, NEW YORK, NY:
 4,017,199, INT. CL. 29.
 JONES & SON FINE JEWELRY, INC., LITTLE ROCK, AR:
 2,911,119, CANC. INT. CL. 9.
 JONES STEPHENS CORPORATION, MOODY, AL:
 4,015,144, PUB. 6-7-2011. MULTIPLE CLASS, INT. CLS. 6
 AND 11.
 JORDAN DREW CORPORATION, TARRYTOWN, NY:
 4,016,378, INT. CL. 20.
 4,016,379, INT. CL. 20.
 JORDI GAINZA DEL RIO, SPAIN:
 4,014,618, PUB. 6-7-2011. INT. CL. 25.
 JORGE NOGUEIRA DIOGO UNIPESSOAL, LDA., 1100-
 LISBOA, PORTUGAL:
 2,910,478, CANC. INT. CL. 42.
 JOS. SCHNEIDER OPTISCHE WERKE GMBH, BAD KREUZ-
 NACH, FED REP GERMANY:
 1,160,700, REN. 7-18-11. INT. CL. 9.

JOSEPH D. LAUZEN, WARRENVILLE, IL:
4,017,168, INT. CL. 35.

JOSEPH L. ASHTON, WOODBURY, CT:
4,015,018, PUB. 3-1-2011. INT. CL. 35.

JOSEPH LOUIS VACCA, OMAHA, NE:
2,910,862, CANC. INT. CL. 42.

JOSHUA C. CUMMINGS, SAN DIEGO, CA, DBA ACETHE-
TIC:
4,015,796, PUB. 6-7-2011. INT. CL. 9.

JOUTEK ELECTRONIC INC., WOODSIDE, NY:
2,481,614, REN. 7-19-11. INT. CL. 9.

JOYOLOGIE, LLC, NEWTOWN, CT:
4,015,210, PUB. 6-7-2011. INT. CL. 41.

JPMORGAN CHASE VASTERA, INC., DULLES, VA:
2,480,919, REN. 7-18-11. INT. CL. 9.
2,480,919, CANC. INT. CL. 35.

JPSR, LLC., ALLEN, TX, DBA A/C TAN AND COPPER TAN:
2,910,756, CANC. INT. CL. 44.

JSC "REALORE", VAIDAUGU, LITHUANIA:
4,016,202, MULTIPLE CLASS, INT. CLS. 9, 38, 41 AND 42.

JSPACE.COM, LLC, CHICAGO, IL:
4,016,647, INT. CL. 42.

JT INTERNATIONAL DISTRIBUTORS, INC., INDIANAPOLIS, IN:
2,910,596, CANC. INT. CL. 18.

JUAREZ, ERNESTO, OJAI, CA:
4,017,370, INT. CL. 35.

JULIE PERRINE INTERNATIONAL, LLC, HIAWATHA, IA,
DBA ALL THINGS ADMIN:
4,015,719, PUB. 6-7-2011. INT. CL. 35.

JUMAN INC., SOUTH EL MONTE, CA:
2,910,170, CANC. INT. CL. 25.

JUMPIES INFLATABLE RENTALS LLC, HILLIARD, OH:
2,911,049, CANC. INT. CL. 41.

JUMY LLC, HOBOKEN, NJ, DBA JOIELLE:
4,014,308, PUB. 6-7-2011. INT. CL. 35.

JUNGHEINRICH AG, 22047 HAMBURG, FED REP GER-
MANY:
2,962,008, CANC. MULTIPLE CLASS, INT. CLS. 6 AND 9.

JUNIOR LEARNING INCORPORATED, HUNTINGTON
BEACH, CA, DBA JUNIOR LEARNING INCORPORATED:
4,016,743, INT. CL. 35.

JUST A LITTLE DITTY, LLC, CHARLOTTESVILLE, VA:
4,015,861, PUB. 6-7-2011. INT. CL. 18.
4,016,029, PUB. 6-7-2011. INT. CL. 41.

JUST FABULOUS, EL SEGUNDO, CA:
4,016,502, INT. CL. 35.

JUST JUMP IT, INC., CHICO, CA:
4,014,770, PUB. 6-7-2011. INT. CL. 28.
4,014,771, PUB. 6-7-2011. INT. CL. 28.

K & H INDUSTRIES, INC., ANGOLA, NY:
2,620,803, CANC. INT. CL. 40.

KAADY CHEMICAL CORP., PORTLAND, OR:
2,412,430, CANC. INT. CL. 37.

KABAM, INC., REDWOOD CITY, CA:
4,017,076, INT. CL. 41.

KABLOOM FLOWERS LLC, ANAHEIM, CA:
2,412,645, CANC. INT. CL. 35.

KABUSHIKI KAISHA HIROSHIMA YASURI SEIZOUSHO,
KURE-SHI, HIROSHIMA 737-0154, JAPAN:
3,976,669, COR. INT. CL. 8.

KABUSHIKI KAISHA HITACHI SEISAKUSHO, CHIYODA-
KU, TOKYO, JAPAN, DBA HITACHI, LTD.:
2,474,742, REN. 7-20-11. INT. CL. 9.

KABUSHIKI KAISHA J.I.F, JAPAN:
4,014,621, PUB. 6-7-2011. INT. CL. 14.

KABUSHIKI KAISHA MELCO HOLDINGS, TRADING AS
MELCO HOLDINGS INC., JAPAN:
4,014,557, PUB. 6-7-2011. INT. CL. 37.

KABUSHIKI KAISHA SEGA, D/B/A SEGA CORPORATION,
JAPAN:
4,014,650, PUB. 6-7-2011. INT. CL. 9.

KABUSHIKI KAISHA SQUARE ENIX HOLDINGS, TOKYO,
JAPAN, TA SQUARE ENIX HOLDINGS CO., LTD.:
4,016,735, INT. CL. 9.

KABUSHIKI KAISHA TANITA, ITABASHI-KU, TOKYO,
JAPAN:
2,967,740, CANC. INT. CL. 44.

KADIDA GASKINS, OXON HILL, MD, DBA SEXXY
SCENTS:
4,015,479, PUB. 6-7-2011. INT. CL. 5.

KADISON, DAVID, DOWNEY, CA:
2,412,891, CANC. INT. CL. 25.

KAHNE, ELLEN L., GLENDALE, NY:
4,015,393, PUB. 6-7-2011. INT. CL. 41.

KAILAS CAPITAL, L.L.C., GREENWICH, CT:
2,910,288, CANC. INT. CL. 36.
2,910,289, CANC. INT. CL. 36.

KAINEXUS LLC, DALLAS, TX:
4,016,900, INT. CL. 42.

KAIZEN ENTERPRISES, INC., FRANKFORT, IL:
4,016,749, INT. CL. 18.

KALMENSON, CYNTHIA, CLAIRE, NASHVILLE, TN:
2,910,261, CANC. INT. CL. 41.

KALUZHSKOE OTKRYTOE AKTSIONERNOE OBSCHES-
TVO KRISTALL, 248016 KALUGA, RUSSIAN FED.:
2,910,558, CANC. INT. CL. 33.

KAMEHAMEHA INVESTMENT CORPORATION, HONO-
LULU, HI:
2,470,890, REN. 7-19-11. INT. CL. 42.
2,470,890, CANC. INT. CL. 25.

KAMIN LLC, MACON, GA:
4,016,542, INT. CL. 1.

KAMP-RITE TENT COT INC., SACRAMENTO, CA:
4,015,960, PUB. 6-7-2011. INT. CL. 20.

KANAKUK MINISTRIES, BRANSON, MO:
2,457,372, REN. 7-16-11. MULTIPLE CLASS, INT. CLS. 25
AND 41.

KANG, MICHAEL, CHING-KWEI, THE WOODLANDS, TX:
2,910,841, CANC. INT. CL. 5.

KANGADIS FOOD INC., HAUPPAUGE, NY:
4,015,399, PUB. 6-7-2011. INT. CL. 29.

KANGAROO MEDIA, INC., MIRABEL, QUEBEC J7N1,
CANADA:
4,017,271, MULTIPLE CLASS, INT. CLS. 9 AND 38.

KANTONAL LLC, MINDEN, NV:
4,016,917, MULTIPLE CLASS, INT. CLS. 21, 25 AND 35.

KAO KABUSHIKI KAISHA, CHUO-KU, TOKYO, JAPAN,
AKA KAO CORPORATION:
4,016,546, INT. CL. 3.
4,016,547, INT. CL. 3.
4,016,548, INT. CL. 3.

KAO KABUSHIKI KAISHA, CHUO-KU, TOKYO, JAPAN,
TA KAO CORPORATION:
4,016,549, INT. CL. 3.

KAPAK COMPANY LLC, ST. LOUIS PARK, MN:
1,621,182, REN. 7-16-11. INT. CL. 16.
1,625,960, REN. 7-16-11. INT. CL. 16.

KAPLAN, JONATHAN, CORAL SPRINGS, FL:
4,015,571, PUB. 6-7-2011. INT. CL. 41.

KAPOHOKINE ADVENTURES, LLC, PEPEEKEO, HI:
4,015,755, PUB. 6-7-2011. INT. CL. 41.

KARAKO SUITS LTD., LYNBROOK, NY:
4,014,958, PUB. 6-7-2011. MULTIPLE CLASS, INT. CLS. 25
AND 35.

KARAPETYAN, TIRAN, YEREVAN, ARMENIA:
4,017,130, INT. CL. 35.

KAREE, JANET M., HARRISBURG, PA:
2,911,193, CANC. INT. CL. 14.

KAREN COLE PAPER LLC, MANAKIN SABOT, VA, DBA
PAPER FANCY:
4,017,217, INT. CL. 35.

KARIMOVA GULNARA ISLAMOVNA, DISTRICT KHAM-
ZA, TASHKENT 100047, UZBEKISTAN:
4,014,455, PUB. 6-7-2011. MULTIPLE CLASS, INT. CLS.
14, 24 AND 25.

KARMISSIE, LLC, LAS VEGAS, CA:
4,014,702, PUB. 6-7-2011. MULTIPLE CLASS, INT. CLS. 3,
5 AND 8.

KARTJANG, INC., JACKSONVILLE, FL:
4,017,136, INT. CL. 29.

KASINA, LLC, NEW YORK, NY:
4,015,624, PUB. 6-7-2011. INT. CL. 36.

KASUNIC, ROB, DARNESTOWN, MD:
2,411,939, CANC. INT. CL. 42.

- KATE SPADE LLC, NEW YORK, NY:
4,017,099, INT. CL. 16.
- KATHRYN C. HAIRSTON, HATTIESBURG, MS:
4,015,332, PUB. 6-7-2011. INT. CL. 20.
- KATOEIZADEH, FARSHID, GUANGZHOU, CHINA:
2,911,281, CANC. INT. CL. 9.
- KATSMAN, DIANA, SHERMAN OAKS, CA AND GIOEV,
DIMITRI, SHERMAN OAKS, CA, AKA GIOYEV, DMI-
TRIY:
4,016,596, INT. CL. 9.
- KATZ, JEFFREY A., VALENCIA, CA:
2,412,762, CANC. MULTIPLE CLASS, INT. CLS. 35 AND
39.
- KATZ, MICHAEL, CAMPBELL, CA:
2,910,978, CANC. INT. CL. 37.
- KATZ, RICHARD, RANCHO SANTA MARGARITA, CA:
4,016,934, MULTIPLE CLASS, INT. CLS. 8 AND 21.
- KAUFMAN, JAMES J., WILMINGTON, NC, DBA DOWN-
STREAM PUBLISHING:
4,016,442, INT. CL. 41.
- KAWASAKI JUKOGYO KABUSHIKI KAISHA, CHUO-KU,
KOBE, JAPAN, DBA KAWASAKI HEAVY INDUSTRIES
LTD.:
2,460,263, REN. 7-21-11. INT. CL. 12.
- KAY, COLLIN, SHERMAN OAKS, CA AND BARNETT,
NATHAN, SHERMAN OAKS, CA:
4,017,140, MULTIPLE CLASS, INT. CLS. 35 AND 42.
- KAYFOAM WOOLFSON, DUBLIN 12, IRELAND:
4,014,817, PUB. 6-7-2011. MULTIPLE CLASS, INT. CLS. 10
AND 20.
- KCD IP, LLC, HOFFMAN ESTATES, IL:
2,911,178, CANC. INT. CL. 12.
- KDB PTY LTD, TOORAK, VICTORIA, 3142, AUSTRALIA:
2,909,876, CANC. INT. CL. 3.
2,909,877, CANC. INT. CL. 3.
- KEATHLEY, FRANK M., SEABROOK, TX, DBA TOP SHELF
ANTIQUES:
2,911,589, CANC. INT. CL. 21.
- KEBD ENTERPRISES, LLC, DENVER, CO:
4,014,869, PUB. 6-7-2011. INT. CL. 5.
- KEL TECHNOLOGIES, KIRTLAND, OH:
4,017,086, INT. CL. 20.
- KELLWOOD COMPANY, CHESTERFIELD, MO:
1,127,554, CANC. INT. CL. 25.
4,016,078, PUB. 6-7-2011. INT. CL. 25.
- KELLY, DANIEL, MEDFORD, NJ:
4,016,538, INT. CL. 20.
- KENO, LESLIE, NEW YORK, NY AND KENO, LEIGH, NEW
YORK, NY:
4,016,814, INT. CL. 20.
- KENT DINUCCI, OMAHA, NE:
4,017,075, INT. CL. 10.
- KENTUCKY-TENNESSEE CLAY COMPANY, NASHVILLE,
TN:
723,228, REN. 7-18-11. U.S. CL. 1 (INT. CL. 1).
- KENWORTHY, NANCY, FAR HILLS, NJ:
4,017,281, INT. CL. 9.
- KERN AG GLOBAL LANGUAGE SERVICES, FRANK-
FURT, FED REP GERMANY:
4,016,246, MULTIPLE CLASS, INT. CLS. 35, 39, 40 AND
41.
- KERN RIVER CORPORATION, KERNVILLE, CA:
4,017,105, MULTIPLE CLASS, INT. CLS. 9 AND 25.
- KERR CORPORATION, ORANGE, CA:
2,909,911, CANC. INT. CL. 10.
- KERZNER INTERNATIONAL RESORTS, INC., PLANTA-
TION, FL, SUN INTERNATIONAL RESORTS, INC., FT.
LAUDERDALE, FL:
2,554,453, REN. 7-15-11. INT. CL. 41.
- KEY BRANDS INTERNATIONAL, LTD., IRWINDALE, CA:
1,179,704, REN. 7-18-11. INT. CL. 3.
- KEYFRAME DIGITAL PRODUCTIONS INC., NIAGARA-
ON-THE-LAKE, ONTARIO, CANADA:
4,016,712, MULTIPLE CLASS, INT. CLS. 9, 38 AND 41.
- KEYGENE, N.V., PW WAGENINGEN, NETHERLANDS:
4,014,741, PUB. 6-7-2011. INT. CL. 42.
- KGP MEDIA LLC, AUSTIN, TX, DBA BUSTED! IN AUSTIN:
4,016,566, INT. CL. 16.
- KHI CAPITAL, INC., VANCOUVER, BRITISH COLUMBIA,
CANADA:
2,474,091, REN. 7-17-11. INT. CL. 2.
- KIAWAH ISLAND INN COMPANY, LLC, KIAWAH IS-
LAND, SC:
2,909,820, CANC. INT. CL. 43.
- KID KNOWLEDGE, INC, ARMONK, NY:
4,017,383, INT. CL. 16.
- KIEFFER BROS., LLC, APPLETON, WI:
4,015,916, PUB. 6-7-2011. INT. CL. 9.
- KIK HOLDCO COMPANY, CONCORD, ONTARIO, CANA-
DA:
2,468,720, REN. 7-20-11. INT. CL. 3.
- KILLGERM GROUP LIMITED, WEST YORKSHIRE, ENG-
LAND:
2,423,006, REN. 7-21-11. INT. CL. 9.
- KIM, PAUL, WHITTIER, CA, DBA US ORTHODONTIC
PRODUCT:
4,015,898, PUB. 6-7-2011. INT. CL. 10.
- KIM, SANG, LUBBOCK, TX:
4,017,178, INT. CL. 14.
- KIM, YOUNG K., ORLANDO, FL:
2,910,948, CANC. INT. CL. 41.
- KIMBALL HILL, INC., ROLLING MEADOWS, IL:
2,910,068, CANC. INT. CL. 37.
- KIMBERLIE SKANDIS /SKANDIS SYSTEMS INTERNA-
TIONAL INC., BRONXVILLE, NY:
2,469,077, REN. 7-16-11. INT. CL. 42.
- KIMBERLY LEPINS, YUCAIPA, CA, DBA CHICKLIT
POWER MINISTRIES:
4,015,643, PUB. 6-7-2011. MULTIPLE CLASS, INT. CLS. 25
AND 41.
- KIMBERLY-CLARK WORLDWIDE, INC., NEENAH, WI:
2,910,825, CANC. INT. CL. 5.
2,910,826, CANC. INT. CL. 5.
- KIMSAPRINCESS, INC., ENCINO, CA:
4,016,172, INT. CL. 14.
- KINETIX LIVING CORP., SEATTLE, WA:
4,016,715, MULTIPLE CLASS, INT. CLS. 5, 16, 29, 30, 32
AND 44.
- KING PRODUCTS INC., MISSISSAUGA, ONTARIO L5N 5S2,
CANADA:
2,909,380, CANC. INT. CL. 9.
- KING SEAFOOD, INC., HOUSTON, TX:
2,412,684, CANC. INT. CL. 42.
- KING, ROBERT L., EUGENE, OR, DBA THE HALOX
COMPANY TO THE HALOX COMPANY, EUGENE, OR:
1,939,524, CANC. INT. CL. 5.
- KINGLY COMMONER LLC, BEAVERTON, OR:
4,016,875, INT. CL. 25.
- KINGSPAN HOLDINGS (IRL) LIMITED, KINGSCOURT,
CO. CAVAN, IRELAND:
2,959,310, CANC. INT. CL. 7.
- KINJIRUSHI KABUSHIKI KAISHA, NAGOYA-SHI, AICHI-
KEN, JAPAN, TA KINJIRUSHI CO., LTD.:
2,910,412, CANC. MULTIPLE CLASS, INT. CLS. 29 AND
30.
- KINSHO CORPORATION, TOKYO 104-6591, JAPAN:
3,964,390, COR. MULTIPLE CLASS, INT. CLS. 6 AND 35.
- KIOSK INFORMATION SYSTEMS, INC., LOUISVILLE, CO:
2,467,087, REN. 7-15-11. INT. CL. 9.
- KIRKPATRICK, CHAD, PORTLAND, OR:
4,016,018, PUB. 6-7-2011. INT. CL. 41.
- KISS CATALOG, LTD., PINE BROOK, NJ:
4,016,074, PUB. 6-7-2011. INT. CL. 9.
4,016,075, PUB. 6-7-2011. INT. CL. 9.
4,016,076, PUB. 6-7-2011. INT. CL. 9.
- KISS CATALOG, LTD., PINE BROOK, NY:
4,016,077, PUB. 6-7-2011. INT. CL. 9.
- KISSMEYER, KIRSTEN, YVETTE, CAMBRIDGE, MA:
4,016,842, INT. CL. 21.
- KITCHEN SOLVERS LLC, LACROSSE, WI:
2,542,956, REN. 7-19-11. INT. CL. 37.
- KITWARE, INC., CLIFTON PARK, NY:
4,015,429, PUB. 6-7-2011. INT. CL. 9.

KIWANIS INTERNATIONAL, INC., INDIANAPOLIS, IN:
2,473,084, REN. 7-19-11. INT. CL. 41.

KLAUSNER, MICHAEL, SHORT HILLS, NJ:
4,015,281, PUB. 6-7-2011. INT. CL. 25.

KLEIN, MICHAEL, SUFFERN, NY AND MAFFEI, VITO,
HAVERSTRAW, NY:
4,015,464, PUB. 6-7-2011. INT. CL. 43.

KLEIN, ROXANNE, CHINO HILLS, CA:
2,556,986, REN. 7-18-11. INT. CL. 30.

KLINGSPOR AG, 35708 HAIGER, FED REP GERMANY:
4,014,648, PUB. 6-7-2011. MULTIPLE CLASS, INT. CLS. 3,
7 AND 8.

KMC MUSIC, INC., BLOOMFIELD, CT:
4,017,122, INT. CL. 9.

KNIGHTS OF AK-SAR-BEN FOUNDATION, OMAHA, NE:
4,014,889, PUB. 6-7-2011. INT. CL. 41.

KNOWLEDGEADVISORS, INC., CHICAGO, IL:
4,016,512, INT. CL. 42.

KNP ASSOCIATES, MOUNTAINSIDE, NJ:
2,910,208, CANC. INT. CL. 35.

KOBO PRODUCTS, INC., SOUTH PLAINFIELD, NJ:
2,909,732, CANC. INT. CL. 35.

KOENIG & BAUER AKTIENGESELLSCHAFT, FED REP
GERMANY:
2,998,484.

KOGER, INC., PARAMUS, NJ:
4,015,299, PUB. 6-7-2011. MULTIPLE CLASS, INT. CLS. 9
AND 42.

KOHJIN CO., LTD., TOKYO, JAPAN, KOHJIN CO., LTD.,
MINATO-KU, TOKYO, JAPAN:
924,925, REN. 7-20-11. U.S. CL. 1 (INT. CL. 17).

KOHJIN CO., LTD., JAPAN:
4,014,555, PUB. 6-7-2011. MULTIPLE CLASS, INT. CLS. 1,
4, 16 AND 17.

KOHLER CO., KOHLER, WI:
4,017,127, INT. CL. 11.

KOLCRAFT ENTERPRISES, INC., CHICAGO, IL:
4,017,229, INT. CL. 12.
4,017,251, INT. CL. 28.

KOLLER ENTERPRISES, INC., SHAWNEE, KS, DBA HAW-
KEYE INTERNATIONAL:
4,015,647, PUB. 6-7-2011. INT. CL. 28.
4,016,081, PUB. 6-7-2011. INT. CL. 21.

KOLMAN, JESSICA, PINOLE, CA, DBA HEYFACES:
4,015,684, PUB. 6-7-2011. INT. CL. 16.

KOLON INDUSTRIES, INC., KWACHON-CITY, KYUNGGI-
DO, REPUBLIC OF KOREA:
2,910,403, CANC. INT. CL. 1.

KOMANETSKY, JAY, THOMAS, SAN ANTONIO, TX:
2,910,336, CANC. INT. CL. 41.

KOMPA S.R.L., I-45100 ROVIGO, ITALY:
4,014,445, PUB. 6-7-2011. MULTIPLE CLASS, INT. CLS. 3,
9, 14, 16, 18 AND 25.

KOMPASS TECHNOLOGY CO., LTD., TAIPEI COUNTY 242,
TAIWAN:
4,014,323, PUB. 6-7-2011. INT. CL. 11.

KONA CAFE COFFEE COMPANY, INC., KIHEI MAUI, HI:
2,909,489, CANC. INT. CL. 30.

KONE INC., LISLE, IL:
4,015,041, PUB. 3-1-2011. INT. CL. 44.

KONINKLIJKE PHILIPS ELECTRONICS N.V., EINDHO-
VEN, NETHERLANDS:
2,909,829, CANC. INT. CL. 9.

KONINKLIJKE PHILIPS ELECTRONICS N.V., NETHER-
LANDS:
4,014,473, PUB. 6-7-2011. INT. CL. 9.
4,014,542, PUB. 6-7-2011. MULTIPLE CLASS, INT. CLS.
11, 21 AND 28.

KONRAD, JEFFREY, ROCK ISLAND, IL:
4,014,934, PUB. 1-11-2011. INT. CL. 9.

KOPP, KENNETH, GREENVILLE, SC:
4,015,521, PUB. 6-7-2011. INT. CL. 42.

KOUWA TRADING LIMITED, BURNABY, BRITISH CO-
LUMBIA, CANADA:
2,909,366, CANC. INT. CL. 25.

KP, INC., VIRGINIA CITY, MT:
2,910,074, CANC. INT. CL. 43.

KRAFT FOODS GLOBAL BRANDS LLC, NORTHFIELD, IL:
2,520,383, REN. 7-15-11. INT. CL. 30.
4,016,918, INT. CL. 29.

KRAFT FOODS SCHWEIZ HOLDING GMBH, ZUG 6301,
SWITZERLAND:
2,909,401, CANC. INT. CL. 30.

KRAFT FOODS SCHWEIZ HOLDING GMBH, 6301 ZUG,
SWITZERLAND:
4,016,874, INT. CL. 11.

KRAJECKI, GARY T., DALLAS, TX:
2,910,929, CANC. INT. CL. 9.

KRESSMANN-BACKMEYER PUBLISHING LLC, AN-
DREWS, NC:
2,524,570, REN. 7-15-11. INT. CL. 16.

KRETEKOTE, LLC, KAUKAUNA, WI:
2,910,025, CANC. INT. CL. 2.

KRIER, ANN, O, LEWISVILLE, NC:
2,910,513, CANC. INT. CL. 18.

KRIPA LLC, NEW YORK, NY:
4,015,843, PUB. 6-7-2011. INT. CL. 14.

KRISTIN EHRGOOD, SAN JUAN, PUERTO RICO:
4,014,364, PUB. 6-7-2011. INT. CL. 35.

KRIZEK, DANE, WASHINGTON, WA:
4,017,334, INT. CL. 25.

KRUEGER BREWING COMPANY, LOVELAND, CO:
4,017,301, INT. CL. 32.

KRUGER PRODUCTS L.P., MISSISSAUGA, ON, CANADA:
4,016,445, INT. CL. 16.

KRUTHOFF, TROY, ROSEVILLE, CA:
4,015,763, PUB. 6-7-2011. INT. CL. 42.

KRÜGER GMBH & CO. KG, FED REP GERMANY:
4,014,595, PUB. 6-7-2011. INT. CL. 3.

KUGEL- UND ROLLENLAGERWERK LEIPZIG GMBH,
LEIPZIG, FED REP GERMANY:
4,014,631, PUB. 6-7-2011. INT. CL. 7.

KUNESTO DIENSTLEISTUNGSGESELLSCHAFT MBH,
FED REP GERMANY:
4,014,503, PUB. 6-7-2011. MULTIPLE CLASS, INT. CLS. 9,
16, 35, 38, 41, 42, 43 AND 45.

KURARAY CO., LTD., KURASHIKI CITY, OKAYAMA
PREFECTURE, JAPAN:
2,447,329, REN. 7-15-11. MULTIPLE CLASS, INT. CLS. 18,
20 AND 28.
2,447,329, CANC. INT. CL. 25.

KUSH AUDIO, LLC, WEST MILFORD, NJ:
4,014,830, PUB. 6-7-2011. INT. CL. 9.
4,014,831, PUB. 6-7-2011. INT. CL. 9.

KWIAT, INC., NEW YORK, NY:
4,015,698, PUB. 6-7-2011. INT. CL. 14.

KWIK TRIP, INC., LA CROSSE, WI:
4,017,078, INT. CL. 29.

KYORAKU INDUSTRIAL CO., LTD., AICHI, JAPAN:
4,014,271, PUB. 6-7-2011. MULTIPLE CLASS, INT. CLS. 9,
28, 29, 30, 31 AND 41.

KYPHON SARL, NEUCHATEL, SWITZERLAND:
4,014,891, PUB. 6-7-2011. INT. CL. 35.

KYZEN CORPORATION, NASHVILLE, TN:
4,015,856, PUB. 6-7-2011. INT. CL. 3.

L & LEUNG HANDBAGS MFY. LTD., NEW TERRITORIES,
HONG KONG:
4,016,890, INT. CL. 18.

L & M SOLUTIONS, INC., LARGO, FL:
4,015,833, PUB. 6-7-2011. INT. CL. 36.

L & R PUBLICATIONS, INC., PORT ORANGE, FL:
2,910,686, CANC. INT. CL. 16.

L. CONGRESS, INC., BONITA SPRINGS, FL:
2,909,724, CANC. INT. CL. 14.

L. ET L., 16100 COGNAC, FRANCE:
2,910,594, CANC. INT. CL. 32.

L. PERRIGO COMPANY, ALLEGAN, MI:
4,017,304, INT. CL. 44.

L.C. LICENSING, INC., NEW YORK, NY:
2,911,758, CANC. INT. CL. 3.

L.G.I. S.R.L., CIUDAD DE BUENOS AIRES, ARGENTINA:
2,911,492, CANC. INT. CL. 9.

L.R. GUY, INC., AUSTIN, TX:
2,909,445, CANC. INT. CL. 25.

- L&L SOLUTIONS, LLC, ELK GROVE, CA:
2,909,678, CANC. INT. CL. 9.
- L&P PROPERTY MANAGEMENT COMPANY, SOUTH GATE, CA:
2,909,573, CANC. INT. CL. 20.
2,909,574, CANC. INT. CL. 20.
- L'EUROPA, GARY A., WARWICK, RI:
2,911,067, CANC. INT. CL. 5.
- L'OCCITANE, FRANCE:
4,014,562, PUB. 6-7-2011. INT. CL. 3.
- L'OREAL, 75008 PARIS, FRANCE:
2,470,877, REN. 7-19-11. INT. CL. 3.
- L'OREAL, PARIS, FRANCE:
4,014,346, PUB. 6-7-2011. INT. CL. 3.
4,014,892, PUB. 6-7-2011. INT. CL. 3.
4,016,530, INT. CL. 3.
4,016,837, INT. CL. 3.
- L'OREAL USA CREATIVE, INC., NEW YORK, NY:
2,910,122, CANC. INT. CL. 3.
2,910,123, CANC. INT. CL. 3.
2,911,634, CANC. INT. CL. 16.
4,016,412, INT. CL. 3.
4,016,652, INT. CL. 3.
4,017,197, INT. CL. 3.
4,017,215, INT. CL. 3.
4,017,241, INT. CL. 36.
- LA BRISA ICE CREAM COMPANY, HOUSTON, TX:
4,017,288, INT. CL. 30.
- LA CAVIAR USA, INC., STATELINE, NV:
4,016,758, INT. CL. 3.
- LA COSTA TIME L.C., CLEARWATER, FL:
2,585,137, REN. 7-18-11. INT. CL. 35.
- LA DOLCE DIVA, INC., MARIETTA, GA:
3,291,557, AM. MULTIPLE CLASS, INT. CLS. 18 AND 25.
- LA MAISON DU CHOCOLAT, NANTERRE, FRANCE:
2,910,405, CANC. INT. CL. 30.
- LA ROCCA, LANCE BRUNO, NOVATO, CA:
4,017,003, INT. CL. 37.
4,017,004, INT. CL. 37.
- LA TAPATIA TORTILLERIA, INC., FRESNO, CA:
4,014,305, PUB. 12-14-2010. INT. CL. 30.
- LA.CE.SA. SOC. COOP, ITALY:
4,014,640, PUB. 6-7-2011. INT. CL. 29.
- LABORATOIRE DE DERMOCOSMETIQUE ACTIVE DOCTEUR PIERRE RICAUD, PARIS, 75008, FRANCE:
2,910,698, CANC. INT. CL. 3.
- LABORATOIRE GARNIER & CIE, PARIS, FRANCE:
2,910,009, CANC. INT. CL. 3.
- LABORATOIRES D'ETHNO-COSMETIQUE ACTINEA, F-85612 MONTAIGU, FRANCE:
4,014,524, PUB. 6-7-2011. INT. CL. 3.
- LABORATOIRES GOEMAR, 35419 SAINT-MALO CEDEX, FRANCE:
4,016,375, INT. CL. 1.
- LABORATOIRES SEROBIOLOGIQUES, INC., CINCINNATI, OH:
1,649,208, REN. 7-16-11. INT. CL. 1.
- LABORATORIOS DE MODA S.A. DE C.V, LEÓN, GUANAJUATO, MEXICO:
4,016,941, INT. CL. 25.
4,016,944, INT. CL. 18.
- LABORATORY INSTITUTE OF MERCHANDISING, NEW YORK, NY:
4,017,344, INT. CL. 41.
- LACY, AUBREY, LAPLACE, LA:
4,016,851, INT. CL. 30.
- LADDER COMPANIES INC., RENO, NV:
2,456,790, CANC. INT. CL. 42.
- LAFARGE CORPORATION, HERNDON, VA:
2,911,370, CANC. INT. CL. 19.
- LAFAYETTE BAND ASSOCIATION, LEXINGTON, KY:
3,031,574, COR. INT. CL. 41.
- LAFFREDI, SHARI A., WILMOT, WI:
2,911,011, CANC. INT. CL. 16.
- LAHA LIMITED, LONDON, UNITED KINGDOM:
4,016,499, MULTIPLE CLASS, INT. CLS. 9 AND 41.
- LAHMEYER INTERNATIONAL GMBH, FED REP GERMANY:
4,014,487, PUB. 6-7-2011. MULTIPLE CLASS, INT. CLS. 35 AND 42.
4,014,491, PUB. 6-7-2011. MULTIPLE CLASS, INT. CLS. 35 AND 42.
- LAKE CITY COMMUNITY COLLEGE, LAKE CITY, FL:
2,412,266, CANC. INT. CL. 41.
- LAKE RESTORATION INC., ROGERS, MN:
4,016,035, PUB. 6-7-2011. INT. CL. 1.
- LAM HO ENTERPRISES, INC., MAUMEE, OH:
4,017,245, INT. CL. 43.
- LAMB & BARNOSKY, LLP, MELVILLE, NY:
4,015,779, PUB. 6-7-2011. INT. CL. 45.
- LAMBDA CROSSING LTD., CAESAREA, ISRAEL:
2,911,375, CANC. INT. CL. 9.
- LAMKIN CORPORATION, SAN DIEGO, CA:
1,674,390, REN. 7-19-11. INT. CL. 28.
- LAMTEC CORPORATION, FLANDERS, NJ:
1,676,779, REN. 7-18-11. INT. CL. 17.
- LANCE MFG. LLC, CHARLOTTE, NC:
2,911,215, CANC. INT. CL. 29.
- LANCE, MARCIE, HIGHLAND PARK, IL, DBA CREATIVE MARKETING ASSOCIATES, INC.:
4,017,209, INT. CL. 35.
- LANCECO INDUSTRIES, INC., PEARL RIVER, NY, DBA C.G. CREATIONS:
4,017,244, INT. CL. 14.
- LANCOME PARFUMS ET BEAUTE & CIE, PARIS, FRANCE:
2,909,890, CANC. INT. CL. 3.
- LAND O'LAKES, INC., ARDEN HILLS, MN:
4,016,886, INT. CL. 29.
- LANG, R. CHRISTOPHER, ALTAMONTE SPRINGS, FL:
2,411,915, CANC. MULTIPLE CLASS, INT. CLS. 35 AND 42.
- LANTMÄNNEN UNIBAKE DENMARK A/S, DENMARK:
4,014,526, PUB. 6-7-2011. INT. CL. 30.
4,014,537, PUB. 6-7-2011. INT. CL. 30.
4,014,538, PUB. 6-7-2011. INT. CL. 30.
- LAPORTE HOLDING, BIOT, FRANCE:
4,014,742, PUB. 6-7-2011. INT. CL. 28.
- LARSON, JULIE, SAN LEANDRO, CA:
2,911,593, CANC. INT. CL. 9.
- LAS VEGAS CONVENTION AND VISITORS AUTHORITY, LAS VEGAS, NV:
4,015,925, PUB. 6-7-2011. INT. CL. 35.
4,016,135, PUB. 6-7-2011. INT. CL. 35.
- LASERSOFT IMAGING, INC., LONGBOAT KEY, FL, DBA LASERSOFT IMAGING USA:
2,910,869, CANC. INT. CL. 9.
- LASIKSURGERY.COM, ARLINGTON, TX, DBA KLEIMAN EVANGELISTA EYE CENTER:
2,909,716, CANC. INT. CL. 44.
- LASSETERS CORPORATION LIMITED, BRISBANE QUEENSLAND 4000, AUSTRALIA:
2,909,410, CANC. INT. CL. 38.
2,909,411, CANC. INT. CL. 35.
- LATE JULY SNACKS LLC, BARNSTABLE, MA:
4,016,163, INT. CL. 30.
4,016,164, INT. CL. 30.
- LATEEF, NADYA, BERKELEY, CA:
4,017,174, INT. CL. 41.
- LATHRAM, CHARLIE, FLORENCE, AL:
2,910,880, CANC. INT. CL. 35.
- LATONDRESSE, JEAN CHRISTOPHER, HOPKINS, MN:
4,014,820, PUB. 6-7-2011. INT. CL. 41.
- LATTANZE, JULIA S, TOWSON, MD:
2,911,409, CANC. INT. CL. 41.
- LAUGHING SOFTWARE, LLC, ENGLEWOOD, CO:
4,016,117, PUB. 6-7-2011. INT. CL. 9.
- LAURA COLESON-SCHREUR, BALTIMORE, MD:
4,014,798, PUB. 6-7-2011. MULTIPLE CLASS, INT. CLS. 44 AND 45.
- LAUREN SIKTBERG, LARGO, FL, DBA ANCHORED STYLE:
4,015,186, PUB. 6-7-2011. INT. CL. 25.
- LAUTIE ALEXANDRE, PARIS, FRANCE:
4,015,810, PUB. 6-7-2011. INT. CL. 9.

LAVA MARKETING GROUP, INC., BIRMINGHAM, MI, AKA LAVA:
4,017,258, INT. CL. 34.

LAVASOFT AB, GÖTEBORG, SWEDEN:
4,014,999, PUB. 5-10-2011. INT. CL. 9.

LAW OFFICE OF AIMEE L. EZZELL, PLLC, WILMINGTON, NC, DBA CONREZ GROUP:
4,015,829, PUB. 6-7-2011. INT. CL. 45.

LAW SCHOOL ADMISSION COUNCIL, INC., NEWTOWN, PA:
2,563,632, REN. 7-18-11. MULTIPLE CLASS, INT. CLS. 41 AND 42.

LAYCOCK, SUSAN S., COTTAGE GROVE, OR, DBA ABSOLUTELY FABULOUS SOAP COMPANY:
4,014,299, PUB. 6-7-2011. INT. CL. 3.

LDT SYSTEMS, INC., CINCINNATI, OH:
2,911,177, CANC. INT. CL. 44.

LE BORDEAUX NORTH INC., CHICAGO, IL:
4,015,137, PUB. 6-7-2011. INT. CL. 43.

LE DOM HAIR & BEAUTY BOUTIQUE, BLOOMINGTON, MN:
4,015,549, PUB. 6-7-2011. INT. CL. 35.

LE PALAIS DES THES S.A., PARIS, FRANCE:
4,015,308, PUB. 6-7-2011. INT. CL. 30.

LE TROPIQUE, INC., COCONUT GROVE, FL:
1,618,340, REN. 7-19-11. INT. CL. 3.

LE, SON D. SALT LAKE CITY, UT:
4,015,083, PUB. 6-7-2011. INT. CL. 35.

LEADERS COSMETICS CO., LTD., SEOUL, REPUBLIC OF KOREA:
4,016,869, INT. CL. 3.

LEADERSHIP PREPARATORY BEDFORD STUYVESANT CHARTER SCHOOL, BROOKLYN, NY:
4,015,320, PUB. 6-7-2011. INT. CL. 41.

LEADERSHIP, EDUCATION AND DEVELOPMENT (LEAD), PHILADELPHIA, PA:
4,016,252, INT. CL. 35.

LEADING RESOURCES, INC., SACRAMENTO, CA:
2,511,617, REN. 7-20-11. INT. CL. 35.

LEAPERS, INC., LIVONIA, MI:
4,015,658, PUB. 6-7-2011. INT. CL. 11.

LEBANESE LADIES CULTURAL SOCIETY, PASADENA, CA:
2,911,195, CANC. INT. CL. 36.

LECO CORPORATION, ST JOSEPH, MI:
394,757, REN. 7-21-11. U.S. CL. 26 (INT. CLS. 9 AND 11).

LEDERER CONSTRUCTION, LLC, CHICAGO, IL, DBA MAHOGANY BUILDERS:
4,014,397, PUB. 6-7-2011. MULTIPLE CLASS, INT. CLS. 37 AND 42.

LEE MEDICAL, INC., FRANKLIN, TN:
2,470,410, REN. 7-15-11. MULTIPLE CLASS, INT. CLS. 35 AND 42.

LEE MYLES AUTO GROUP, LLC, LEESPORT, PA:
1,159,436, REN. 7-20-11. INT. CL. 37.

LEE VALLEY CLOTHING LTD., COUNTY CORK, IRELAND:
2,483,226, REN. 7-19-11. INT. CL. 25.

LEE, MICHAEL, NORTH EGREMONT, MA:
4,015,062, PUB. 6-7-2011. INT. CL. 41.

LEEOLOGIC INC, MOBILE, AL:
4,016,314, INT. CL. 35.

LEGAL AID SOCIETY-EMPLOYMENT LAW CENTER, SAN FRANCISCO, CA:
4,016,634, INT. CL. 45.

LEGORRETA, ANTONIO, WESTLAKE VILLAGE, CA:
4,015,323, PUB. 6-7-2011. INT. CL. 42.

LEHAN IMPORTS, LLC, NIWOT, CO:
3,943,348, COR. INT. CL. 18.

LEJAN ENTERTAINMENT INC, STUDIO CITY, CA:
4,014,841, PUB. 6-7-2011. INT. CL. 41.

LEKOOL INC., CHENGDU, CHINA:
4,015,858, PUB. 6-7-2011. INT. CL. 41.

LEONHARDT, MICHAEL, GARDEN CITY, UT:
4,015,662, PUB. 6-7-2011. INT. CL. 43.

LEONISA S.A., MEDELLIN, COLOMBIA:
2,467,355, REN. 7-19-11. INT. CL. 25.

LERNER GREENBERG STEMER LLP, HOLLYWOOD, FL:
2,511,832, REN. 7-19-11. INT. CL. 42.

LEROY HILL COFFEE COMPANY, INC., MOBILE, AL, LEROY HILL COFFEE COMPANY, INC., MOBILE, AL:
2,498,613, REN. 7-15-11. MULTIPLE CLASS, INT. CLS. 29 AND 30.

LES BOISSONS TIGERADE INC., VALLEYFIELD, PROVINCE OF QUEBEC, CANADA:
2,909,556, CANC. INT. CL. 32.

LESLIE SINGER, LLC, WESTPORT, CT:
2,910,221, CANC. INT. CL. 25.

LETOURNEAU TECHNOLOGIES, INC., HOUSTON, TX:
1,152,948, REN. 7-16-11. INT. CL. 9.

LETTERS & SCIENCES, LLC, WHIPPANY, NJ:
4,015,491, PUB. 6-7-2011. INT. CL. 41.

LEUPOLD & STEVENS, INC., BEAVERTON, OR, REDFIELD CO., DENVER, CO:
921,093, REN. 7-15-11. U.S. CL. 26 (INT. CLS. 1, 9 AND 10).

LEUPOLD & STEVENS, INC., BEAVERTON, OR:
2,576,067, REN. 7-18-11. INT. CL. 9.

LEVERAGE LANDING NET, LLC, OXFORD, MI:
4,017,290, INT. CL. 28.

LEVINE, RUSSELL, SAN DIEGO, CA:
4,016,384, INT. CL. 3.

LEVTECH, INC., LEXINGTON, KY:
2,910,693, CANC. INT. CL. 7.

LEWA GMBH, FED REP GERMANY:
4,014,482, PUB. 6-7-2011. MULTIPLE CLASS, INT. CLS. 7 AND 9.

LEWIS BROTHERS BAKERIES INCORPORATED, EVANSVILLE, IN, DBA LEWIS BAKERIES, INC.:
1,652,538, REN. 7-20-11. INT. CL. 30.

LEWIS, HOLLY, PALMER, AK:
4,015,551, PUB. 6-7-2011. INT. CL. 41.

LEXINGTON PROFESSIONAL BASEBALL COMPANY, LLC, LEXINGTON, KY:
2,530,759, REN. 7-19-11. INT. CL. 41.
2,533,009, REN. 7-18-11. INT. CL. 41.

LEYLAND SPORTS, INC., SPOKANE, WA:
2,910,401, CANC. MULTIPLE CLASS, INT. CLS. 25 AND 28.

LF, LLC, MOUNT MOURNE, NC:
4,016,643, MULTIPLE CLASS, INT. CLS. 35, 40 AND 41.

LG ELECTRONICS INC., SEOUL, REPUBLIC OF KOREA:
4,014,392, PUB. 6-7-2011. INT. CL. 9.

LHK PARTNERS, INC., NEWTOWN SQUARE, PA:
4,016,113, PUB. 6-7-2011. INT. CL. 35.
4,016,114, PUB. 6-7-2011. INT. CL. 35.

LIBERTY COUNSEL, INC., ORLANDO, FL, AKA LIBERTY COUNCIL:
4,015,692, PUB. 6-7-2011. INT. CL. 16.

LIBERTY HARDWARE MFG. CORP., WINSTON-SALEM, NC:
2,911,422, CANC. INT. CL. 6.

LIBERTY MUTUAL INSURANCE COMPANY, BOSTON, MA:
2,910,370, CANC. INT. CL. 36.

LICHTENSTEIN, GREGG A., MARGATE, NJ, DBA COLLABORATIVE STRATEGIES:
2,456,892, REN. 7-18-11. INT. CL. 35.

LICOS TRUCKTEC GMBH, 88677 MARKDORF, FED REP GERMANY:
4,014,474, PUB. 6-7-2011. MULTIPLE CLASS, INT. CLS. 9 AND 12.

LIDL STIFTUNG & CO. KG, NECKARSULM, FED REP GERMANY:
2,910,428, CANC. MULTIPLE CLASS, INT. CLS. 29 AND 30.

LIDL STIFTUNG & CO. KG, NECKARSULM, 74167, FED REP GERMANY:
2,910,495, CANC. INT. CL. 29.
2,910,496, CANC. INT. CL. 31.
2,910,572, CANC. INT. CL. 29.

LIDL STIFTUNG & CO. KG, NECKARSULM, FED REP GERMANY:
2,910,573, CANC. MULTIPLE CLASS, INT. CLS. 29 AND

30.
2,910,604, CANC. INT. CL. 33.
2,910,660, CANC. INT. CL. 33.
- LIDL STIFTUNG & CO. KG, FED REP GERMANY:
4,014,468, PUB. 6-7-2011. MULTIPLE CLASS, INT. CLS. 4, 6, 11, 20, 21, 22, 24, 25 AND 27.
4,014,551, PUB. 6-7-2011. MULTIPLE CLASS, INT. CLS. 14, 18 AND 25.
- LIFE AND HEALTH INSURANCE FOUNDATION FOR EDUCATION, ARLINGTON, VA:
4,014,703, PUB. 6-7-2011. INT. CL. 35.
- LIFE GEAR CORPORATION, JAPAN:
4,014,454, PUB. 6-7-2011. INT. CL. 25.
- LIFE TRANSITIONS ADVISORS, LLC, NORCROSS, GA:
4,017,366, INT. CL. 41.
4,017,367, INT. CL. 41.
4,017,368, INT. CL. 41.
- LIFEFORCE, LLC, BURR RIDGE, IL:
4,016,387, INT. CL. 41.
- LIFETIME TOYS PTY LTD, CLEAR ISLAND WATERS, AUSTRALIA:
4,015,327, PUB. 6-7-2011. INT. CL. 28.
- LIFEXPAND, INC., BOCA RATON, FL:
2,911,045, CANC. INT. CL. 5.
- LIGHTHOUSE CARWASH SYSTEMS, LLC, INDIANAPOLIS, IN:
2,910,086, CANC. INT. CL. 3.
- LIGHTHOUSE DISPLAY INTERNATIONAL LTD., NOTTINGHAM, GREAT BRITAIN:
4,016,587, INT. CL. 20.
- LIGNELLI, JAMES E., PITTSBURGH, PA, DBA DIVERSIFIED EVALUATION COMPANY:
2,468,613, REN. 7-16-11. MULTIPLE CLASS, INT. CLS. 36 AND 42.
- LIGNOR LIMITED, MELBOURNE, VICTORIA, AUSTRALIA:
4,014,717, PUB. 6-7-2011. MULTIPLE CLASS, INT. CLS. 19 AND 31.
- LIM, THOMAS, OAKLAND, CA:
4,017,386, INT. CL. 35.
- LIMO ANYWHERE, INC., DALLAS, TX:
4,015,731, PUB. 6-7-2011. MULTIPLE CLASS, INT. CLS. 9 AND 35.
- LIN, CHUNYI, CHANHASSEN, MN:
2,464,858, REN. 7-18-11. INT. CL. 9.
- LIN, JONATHAN C., SAN RAFAEL, CA, DBA ATIQTUQ:
4,017,237, INT. CL. 41.
- LINDALUX INC., WESTMINSTER, CA:
2,910,129, CANC. INT. CL. 5.
2,910,130, CANC. INT. CL. 5.
2,910,131, CANC. INT. CL. 5.
2,910,132, CANC. INT. CL. 5.
- LINDE AKTIENGESELLSCHAFT, 80331 MÜNCHEN/MUNICH, FED REP GERMANY, AKA LINDE AG:
4,016,473, MULTIPLE CLASS, INT. CLS. 11 AND 42.
- LINE-X ACQUISITION LLC, HUNTSVILLE, AL:
2,461,464, REN. 7-18-11. INT. CL. 40.
2,463,701, REN. 7-18-11. MULTIPLE CLASS, INT. CLS. 2 AND 40.
- LINEPHARMA SARL, MONTREUIL, PARIS, FRANCE:
4,015,790, PUB. 6-7-2011. MULTIPLE CLASS, INT. CLS. 5 AND 44.
- LINK MARKETING, INC., ATLANTA, GA:
4,015,990, PUB. 6-7-2011. INT. CL. 35.
- LINK RESOURCES, INC., MARIETTA, GA:
2,412,553, CANC. INT. CL. 35.
- LINK, PAUL A., WISCONSIN RAPIDS, WI:
2,911,142, CANC. INT. CL. 9.
- LINKEDIN CORPORATION, MOUNTAIN VIEW, CA:
4,016,684, INT. CL. 41.
4,016,685, INT. CL. 41.
4,016,686, INT. CL. 45.
4,016,687, INT. CL. 41.
4,016,688, INT. CL. 45.
- LIONS GATE ENTERTAINMENT, INC., SANTA MONICA, CA:
4,016,709, INT. CL. 28.
- LIQUI - MOLY GESELLSCHAFT MIT BESCHRÄNKTER HAFTUNG, 89081 ULM, FED REP GERMANY:
4,014,641, PUB. 6-7-2011. MULTIPLE CLASS, INT. CLS. 1 AND 4.
- LIQUID MEASUREMENT SYSTEMS, INC., GEORGIA, VT:
4,014,283, PUB. 8-18-2009. MULTIPLE CLASS, INT. CLS. 40 AND 42.
- LITTLE CREEK FARMS, NEWARK, OH:
4,015,636, PUB. 6-7-2011. INT. CL. 29.
- LITTLE DIVERSIFIED ARCHITECTURAL CONSULTING, INC., CHARLOTTE, NC TO LITTLE DIVERSIFIED ARCHITECTURAL CONSULTING, INC., CHARLOTTE, NC:
3,068,593, CANC. INT. CL. 42.
- LITTLE KIDS PREFERRED, LLC, DAYTON, NJ:
2,909,704, CANC. INT. CL. 28.
2,909,705, CANC. INT. CL. 28.
- LITTLE SCIENTISTS CORP., WOODBRIDGE, CT:
2,412,869, CANC. INT. CL. 9.
- LIU, GEORGE YIH JONG, SOUTH EL MONTE, CA:
2,413,084, CANC. INT. CL. 31.
- LIVE NATION WORLDWIDE, INC., BEVERLY HILLS, CA:
2,453,172, REN. 7-15-11. INT. CL. 41.
- LIVEYEARBOOK, INC., NEENAH, WI:
4,016,963, INT. CL. 41.
- LIVING WELL HEALTH SOLUTIONS, LLC, CHARLOTTE, NC:
4,014,672, PUB. 1-4-2011. INT. CL. 44.
- LIZEO ONLINE MEDIA GROUP, FRANCE:
4,014,496, PUB. 6-7-2011. INT. CL. 35.
- LLOYD'S GARAGE, LLC, NAPA, CA:
4,015,728, PUB. 6-7-2011. INT. CL. 41.
- LMS INTELLIBOUND, INC, TUCKER, GA:
2,910,835, CANC. INT. CL. 39.
- LOCKHEED MARTIN CORPORATION, BETHESDA, MD:
2,911,601, CANC. INT. CL. 9.
4,016,418, INT. CL. 28.
- LOCOS FRANCHISE COMPANY, INC., ATHENS, GA:
2,479,276, REN. 7-21-11. INT. CL. 42.
- LOEB, JOHN L. JR., NEW YORK, NY:
4,014,225, PUB. 6-7-2011. INT. CL. 33.
- LOFFLES, WILMINGTON, DE:
4,017,119, INT. CL. 41.
- LOFLI JEANS LIMITED, LONDON, UNITED KINGDOM:
2,969,734, CANC. INT. CL. 26.
- LOFTON, KIMBERLY, MOHEGAN LAKE, NY:
4,015,609, PUB. 6-7-2011. INT. CL. 42.
- LOG HOUSE PLANTS, COTTAGE GROVE, OR:
2,909,999, CANC. INT. CL. 31.
- LOGENII LLC, MINNEAPOLIS, MN:
2,910,508, CANC. INT. CL. 42.
- LOGICSOURCE, INC., NORWALK, CT:
4,016,025, PUB. 6-7-2011. INT. CL. 42.
- LOGIX GURU LLC, MURRYSVILLE, PA, DBA LOGIX GURU:
4,014,774, PUB. 6-7-2011. MULTIPLE CLASS, INT. CLS. 35 AND 42.
- LOJACK CORPORATION, WESTWOOD, MA:
4,014,763, PUB. 6-7-2011. MULTIPLE CLASS, INT. CLS. 20 AND 45.
- LONDON BRIDGE RESORT, LLC, KING OF PRUSSIA, PA:
2,909,807, CANC. INT. CL. 32.
- LONDON CONSULTING GROUP, INC., BEVERLY HILLS, CA, DBA LONDON CONSULTING GROUP:
4,015,053, PUB. 6-7-2011. INT. CL. 35.
4,015,055, PUB. 6-7-2011. INT. CL. 35.
- LONG & FOSTER COMPANIES, INC., THE, FAIRFAX, VA:
2,412,503, CANC. INT. CL. 35.
- LONG CLAWSON DAIRY LIMITED, LEICESTERSHIRE, ENGLAND:
2,500,741, REN. 7-18-11. INT. CL. 29.
- LONG CLAWSON DAIRY LIMITED, LEICESTERSHIRE, GREAT BRITAIN:
2,511,061, REN. 7-19-11. INT. CL. 29.
- LONG FAITH (ZHONGSHAN) INDUSTRIAL CO., LTD., ZHONGSHAN, GUANGDONG, CHINA:
4,015,818, PUB. 6-7-2011. INT. CL. 12.
- LONG LIFE MAXX, INC., LOS ANGELES, CA:
2,470,848, REN. 7-15-11. INT. CL. 5.

LORAMA INC., MILTON, ONTARIO, CANADA:
4,014,358, PUB. 6-7-2011. INT. CL. 1.
4,014,359, PUB. 6-7-2011. INT. CL. 1.

LORENZANA & ASSOCIATES, LLC, MORTON GROVE, IL:
4,017,365, INT. CL. 41.

LORILLARD LICENSING COMPANY, LLC, GREENSBORO,
NC:
4,015,899, PUB. 6-7-2011. INT. CL. 34.

LOTUS BAKERIES, LEMBEKE, BELGIUM:
4,014,431, PUB. 2-15-2011. INT. CL. 30.

LOTUS BLOSSOM, INC., SANDY, UT:
2,469,733, REN. 7-19-11. INT. CL. 13.
2,473,603, REN. 7-15-11. INT. CL. 41.

LOUIS VUITTON MALLETTIER, PARIS, FRANCE, VUITTON
& VUITTON, SOCIETE A RESPONSABILITE LIMITEE,
PARIS, FRANCE:
286,345, REN. 7-16-11. U.S. CL. 3 (INT. CL. 18).

LOUIS VUITTON MALLETTIER, PARIS, FRANCE:
4,014,581, PUB. 6-7-2011. INT. CL. 14.

LOVE, JOE, LONG BEACH, CA:
2,910,379, CANC. INT. CL. 41.

LOVEOPOLIS, INC., BURLINGTON, VT:
4,016,000, PUB. 6-7-2011. MULTIPLE CLASS, INT. CLS. 38
AND 45.

LOWE, JAMES H., MERCER ISLAND, WA, DBA ERISIONI
PRODUCTIONS INTERNATIONAL:
2,911,146, CANC. INT. CL. 9.

LOXCREEN CANADA LTD., MISSISSAUGA, ONTARIO,
CANADA:
4,016,461, MULTIPLE CLASS, INT. CLS. 6 AND 19.

LS CABLE LTD., ANYANG-SI, REPUBLIC OF KOREA:
4,014,347, PUB. 6-7-2011. INT. CL. 9.

LSR HYPERION TM LLC, UNIONDALE, NY:
2,411,625, CANC. INT. CL. 35.

LSR PERFORMANCE, LLC, POMPANO BEACH, FL:
4,016,446, MULTIPLE CLASS, INT. CLS. 12 AND 35.
4,016,448, MULTIPLE CLASS, INT. CLS. 12 AND 35.

LUBRI-LAB INC., BOUCHERVILLE, QUEBEC J4B 8A3,
CANADA:
2,911,078, CANC. INT. CL. 42.

LUC DEPROST, B-9230 WETTEREN, BELGIUM:
4,014,528, PUB. 6-7-2011. INT. CL. 42.

LUC-BERJEN PARIS LTD., WEYBRIDGE, SURREY KT13
8XR, ENGLAND:
1,627,128, CANC. MULTIPLE CLASS, INT. CLS. 18 AND
25.

LUCIANA MACHADO SIMON, SPRINGFIELD, PA AND
JOSH SIMON, SPRINGFIELD, PA:
4,015,723, PUB. 6-7-2011. INT. CL. 25.

LUIGI DI GIROLAMO MALDERA, EDO MIRANDA, VE-
NEZUELA:
4,016,369, INT. CL. 3.

LUSHINGTON GARRELL, LOS ANGELES, CA:
4,016,388, INT. CL. 25.

LUXEXCEL HOLDING B.V., NETHERLANDS:
4,014,638, PUB. 6-7-2011. INT. CL. 40.

LVD ACQUISITION, LLC, COLUMBUS, OH:
2,412,093, CANC. INT. CL. 11.

LYLE, STEPHEN M., LOS ANGELES, CA:
4,017,073, INT. CL. 35.

LYNETTE ARLENE SEYFERT, GRASS VALLEY, CA, AKA
LYNETTE ARLENE:
4,015,027, PUB. 3-1-2011. INT. CL. 3.

LYON, DENNIS BOWER, OCEANSIDE, CA:
4,014,287, PUB. 6-7-2011. INT. CL. 45.

LYONS, THOMAS, ATLANTA, GA:
4,014,784, PUB. 6-7-2011. INT. CL. 10.

LYTLE ENTERPRISES, LLC, HIGHLANDS RANCH, CO:
4,014,748, PUB. 6-7-2011. INT. CL. 28.

L2M ASSOCIATES, INC., REDWOOD CITY, CA:
4,015,328, PUB. 6-7-2011. MULTIPLE CLASS, INT. CLS. 35
AND 41.

M CUBED TECHNOLOGIES, INC., MONROE, CT:
4,015,135, PUB. 6-7-2011. INT. CL. 9.

M.C.A.-MEDICAL AND CHEMICAL AGENCY S.R.A., MI-
LANO, ITALY:
2,909,349, CANC. INT. CL. 3.

M.D. APOTHECARY, INC., WESTLAKE VILLAGE, CA,
FORMERLY ORTHOPEDIC APOTHECARY, INC.:
4,016,430, INT. CL. 5.

MAC LEAN-FOGG COMPANY, MUNDELEIN, IL, RELI-
ABLE ELECTRIC COMPANY, FRANKLIN PARK, IL:
725,802, REN. 7-15-11. U.S. CL. 13 (INT. CL. 6).

MACIAS MEDINA, EVERARDO, JALPA, MEXICO:
4,014,301, PUB. 6-7-2011. INT. CL. 33.

MACK TRUCKS, INC., GREENSBORO, NC:
2,459,944, REN. 7-21-11. INT. CL. 25.

MACKENZIE HUGHES, LLP, SYRACUSE, NY:
2,581,823, REN. 7-16-11. INT. CL. 42.

MACMILLAN USA, INC., INDIANAPOLIS, IN TO PEARSON
EDUCATION, INC., UPPER SADDLE RIVER, NJ:
2,411,768, CANC. INT. CL. 16.

MACROTRANSPORT SERVICES, LLC, DAYTONA BEACH,
FL:
4,015,838, PUB. 6-7-2011. INT. CL. 39.

MACY'S MERCHANDISING GROUP, INC., NEW YORK,
NY:
2,911,687, CANC. INT. CL. 24.

MAD SCIENTISTS BREWING PARTNERS LLC, BROOK-
LYN, NY, DBA SIXPOINT CRAFT ALES:
4,017,242, INT. CL. 36.

MADISON BUILDERS, LLC, ATLANTA, GA:
2,910,168, CANC. INT. CL. 37.

MADL, TIVADAR, VENTURA, CA, DBA MSC RECORDS:
4,015,020, PUB. 6-7-2011. INT. CL. 9.

MAEDA, PHILIP, TORRANCE, CA:
4,016,520, INT. CL. 9.

MAG & BROOK, INC., GARDEN GROVE, CA:
4,017,194, INT. CL. 11.

MAG INSTRUMENT, INC., ONTARIO, CA:
4,016,095, PUB. 6-7-2011. INT. CL. 11.
4,016,096, PUB. 6-7-2011. INT. CL. 11.

MAGASCHONI APPAREL GROUP, INC., NEW YORK, NY:
4,016,798, INT. CL. 25.

MAGDA, CINDY, TUCSON, AZ:
2,910,972, CANC. MULTIPLE CLASS, INT. CLS. 16, 20
AND 25.

MAGGIORE, JOSEPH P, CARLSBAD, CA:
4,014,257, PUB. 6-7-2011. INT. CL. 43.

MAGIC BY RANDY, INC., GLENVIEW, IL:
4,017,306, INT. CL. 28.

MAGID GLOVE AND SAFETY MANUFACTURING CO.,
L.L.C., CHICAGO, IL:
4,014,240, PUB. 6-7-2011. INT. CL. 9.

MAGNOLIA OPERATING, LLC, NEW YORK, NY:
4,015,572, PUB. 6-7-2011. MULTIPLE CLASS, INT. CLS. 30
AND 35.

MAGO SIMMONE A., BAYAMON, PUERTO RICO:
4,017,102, INT. CL. 9.

MAJOR LEAGUE BASEBALL PLAYERS ALUMNI ASSO-
CIATION, COLORADO SPRINGS, CO:
2,571,015, REN. 7-21-11. MULTIPLE CLASS, INT. CLS. 16,
18, 25, 41 AND 42.

MAKAHA GROUP, LLC., CORONA DEL MAR, CA:
2,482,670, REN. 7-15-11. INT. CL. 25.

MAKE-UP DESIGNORY, VALENCIA, CA:
4,015,958, PUB. 6-7-2011. MULTIPLE CLASS, INT. CLS. 3,
21 AND 41.

MAKING MEMORIES WHOLESALE, INC., CENTERVILLE,
UT, DBA MAKING MEMORIES, INC.:
2,910,582, CANC. INT. CL. 16.

MAKPOWER TECHNOLOGY, WINDSOR, ONTARIO, CA-
NADA:
4,015,110, PUB. 6-7-2011. INT. CL. 9.

MAKRO GRUP ELEKTRONIK MÜHENDISLIK SANAYI VE
TICARET ANONIM SİRKETİ, TURKEY:
4,014,543, PUB. 6-7-2011. INT. CL. 9.

MALIBU DREAM GIRL, LOS ANGELES, CA:
2,491,698, REN. 7-15-11. INT. CL. 25.

MALIBU KIDZ, LLC, SUNNYVALE, CA:
4,016,535, INT. CL. 25.

MALIBU LUMBER, LLC, MALIBU, CA:
4,014,298, PUB. 6-7-2011. MULTIPLE CLASS, INT. CLS. 35
AND 36.

- MALKI, CHARLES, ORANGE, CA:
2,910,673, CANC. INT. CL. 35.
- MALOUF MARKETING, INC., LOGAN, UT, DBA MALOUF FINE LINENS:
4,014,719, PUB. 6-7-2011. INT. CL. 24.
- MAMAKALL COMMUNICATION, INC., LOS ANGELES, CA:
2,910,388, CANC. INT. CL. 9.
- MAMAPOP LLC, BALTIMORE, MD:
4,014,936, PUB. 6-7-2011. INT. CL. 41.
- MAMUNIA INVESTMENT, S.A., 28002 MADRID, SPAIN:
2,910,314, CANC. INT. CL. 9.
- MANDEL, PAMELA D., SEATTLE, WA:
4,016,014, PUB. 6-7-2011. INT. CL. 41.
- MANDOUR & ASSOCIATES, APC, SAN DIEGO, CA:
4,017,425, INT. CL. 45.
- MANITOU AND PIKES PEAK RAILWAY CO., MANITOU SPRINGS, CO:
1,690,255, REN. 7-18-11. INT. CL. 25.
- MANITOWOC FOODSERVICE COMPANIES, LLC, MANITOWOC, WI:
4,017,093, INT. CL. 11.
- MANNING, MARCY DENMARK, STERLING, VA:
2,586,996, REN. 7-19-11. INT. CL. 41.
- MANOEL D. POÇAS JÚNIOR-VINHOS, S.A., PORTUGAL:
4,014,443, PUB. 6-7-2011. INT. CL. 33.
- MANUEL OSTNER, 93059 REGENSBURG, FED REP GERMANY:
4,014,649, PUB. 6-7-2011. MULTIPLE CLASS, INT. CLS. 11, 12 AND 41.
- MANYONE NETWORKS, INC., SAN MATEO, CA:
2,911,423, CANC. INT. CL. 42.
- MAP CREATIVE PTY LTD, AUSTRALIA:
4,014,552, PUB. 6-7-2011. INT. CL. 25.
- MAPEI S.P.A., 20158 MILAN, ITALY:
2,909,675, CANC. INT. CL. 1.
- MAPLE LEAF DISTILLERS INC., WINNIPEG, MANITOBA R3E 2K3, CANADA:
2,911,318, CANC. INT. CL. 33.
- MAQUET CARDIOPULMONARY AG, HIRRLINGEN, FED REP GERMANY:
2,471,761, REN. 7-19-11. INT. CL. 10.
- MARATHON APPAREL CORPORATION, CHILDERSBURG, AL:
2,911,791, CANC. INT. CL. 25.
- MARATHON EQUIPMENT COMPANY, VERNON, AL:
2,911,443, CANC. INT. CL. 7.
- MARATHON EQUIPMENT COMPANY (DELAWARE), VERNON, AL, DELAWARE CAPITAL FORMATION, INC., WILMINGTON, DE:
2,562,928, REN. 7-16-11. MULTIPLE CLASS, INT. CLS. 6 AND 7.
- MARC DANIEL LUBART, THORNWOOD, NY, DBA IO-BYTE SOLUTIONS, INC.:
4,015,699, PUB. 6-7-2011. INT. CL. 42.
- MARCAL PAPER MILLS, LLC, ELMWOOD PARK, NJ:
1,627,099, REN. 7-21-11. INT. CL. 16.
- MARCHAND D'ETOILES, PARIS, FRANCE:
4,014,951, PUB. 6-7-2011. INT. CL. 25.
- MARCHON EYEWEAR, INC., MELVILLE, NY:
2,474,283, REN. 7-15-11. INT. CL. 9.
4,016,136, PUB. 6-7-2011. INT. CL. 9.
- MARCO RUBIN, ARLINGTON, VA:
4,015,509, PUB. 6-7-2011. MULTIPLE CLASS, INT. CLS. 35 AND 36.
- MAREL HF, ICELAND:
4,014,541, PUB. 6-7-2011. INT. CL. 11.
- MARGARET H. BITLER, NEW YORK, NY, DBA NOTTI TOFFEE:
4,016,439, INT. CL. 30.
- MARGIE YOUNG LEMONS, SPICEWOOD, TX, DBA HILL COUNTRY HAIKU:
4,014,325, PUB. 11-17-2009. INT. CL. 3.
- MARICOPA COUNTY EMPLOYEES FEDERAL CREDIT UNION, PHOENIX, AZ:
2,911,530, CANC. INT. CL. 36.
- MARINE GEEK, INC., MIAMI, FL:
4,015,247, PUB. 6-7-2011. MULTIPLE CLASS, INT. CLS. 35, 38 AND 41.
- MARINE HYDRAULIC ENGINEERING CO., INC., ROCKLAND, ME:
917,624, REN. 7-18-11. U.S. CL. 23 (INT. CL. 7).
- MARIO LEMIEUX, PITTSBURGH, PA:
4,016,462, INT. CL. 28.
- MARIO TRICOCI HAIR SALON AND DAY SPAS, INC., PHOENIX, AZ:
2,911,345, CANC. INT. CL. 3.
2,911,575, CANC. INT. CL. 42.
- MARION D. HOLMES, LAURELTON, NY:
4,016,284, INT. CL. 26.
- MARK ANTHONY INTERNATIONAL SRL, ST. MICHAEL, BARBADOS:
4,016,629, MULTIPLE CLASS, INT. CLS. 32 AND 33.
- MARK NORTHCUTT, KATY, TX:
4,016,063, PUB. 6-7-2011. INT. CL. 5.
- MARK VII EQUIPMENT INC., ARVADA, CO:
2,910,618, CANC. INT. CL. 9.
- MARKER VÖLKL (INTERNATIONAL) GMBH, CH-6341 BAAR, SWITZERLAND:
4,014,593, PUB. 6-7-2011. MULTIPLE CLASS, INT. CLS. 9, 18, 25, 28 AND 41.
- MARKET SHIELD CAPITAL, LLC, NATICK, MA:
4,016,567, INT. CL. 36.
- MARKETGID USA, INC., MARIETTA, GA:
4,015,106, PUB. 3-1-2011. INT. CL. 35.
- MARLENA INTERNATIONAL, LLC, LAWRENCEVILLE, GA:
4,014,424, PUB. 6-7-2011. MULTIPLE CLASS, INT. CLS. 10 AND 25.
- MARLON BLAIR, ELK GROVE, CA, DBA GO HARD CLOTHING A DESIGN BY MARLON BLAIR:
4,016,563, INT. CL. 25.
- MARS, INCORPORATED, MCLEAN, VA:
2,911,259, CANC. INT. CL. 41.
4,016,714, INT. CL. 30.
- MARSHALL FAULK FOUNDATION, SAN DIEGO, CA:
4,014,366, PUB. 6-7-2011. MULTIPLE CLASS, INT. CLS. 25 AND 28.
- MARTHA STEWART LIVING OMNIMEDIA, INC., NEW YORK, NY:
4,016,300, MULTIPLE CLASS, INT. CLS. 6 AND 16.
- MARTIN FUID POWER COMPANY, TROY, MI:
4,015,132, PUB. 6-7-2011. INT. CL. 17.
- MARTIN PROFESSIONAL A/S, 8200 AARHUS N, DENMARK:
2,910,292, CANC. MULTIPLE CLASS, INT. CLS. 9, 11, 35, 37 AND 42.
- MARTIN, ADAM, MT PLEASANT, SC:
4,015,888, PUB. 6-7-2011. INT. CL. 36.
- MARTIN, HEIDI, CASCO, ME:
4,017,077, INT. CL. 3.
- MARTIN, RUSSELL, BURLINGTON, VT:
4,015,732, PUB. 6-7-2011. INT. CL. 25.
- MARVEL CHARACTERS, INC., MANHATTAN BEACH, CA:
4,016,286, INT. CL. 16.
4,016,484, INT. CL. 21.
4,016,485, INT. CL. 18.
- MARVELL WORLD TRADE LTD., ST. MICHAEL, BARBADOS:
4,016,255, INT. CL. 9.
4,016,264, INT. CL. 9.
- MARY G. RAGO, PITTSBURGH, PA, DBA MARA PHOTOGRAPHY:
4,015,808, PUB. 6-7-2011. INT. CL. 4.
- MARY KAY INC., DALLAS, TX:
2,910,239, CANC. INT. CL. 41.
2,910,240, CANC. INT. CL. 41.
- MARY KAY INC., ADDISON, TX:
2,929,134, CANC. INT. CL. 25.
- MARY SHANE, INC., MARLBOROUGH, MA:
2,910,013, CANC. INT. CL. 44.
- MARYAM YOUSEFI, LOS GATOS, CA:
4,015,652, PUB. 6-7-2011. INT. CL. 43.
- MASAFUMI WATANABE, TOKYO, JAPAN:
4,016,770, MULTIPLE CLASS, INT. CLS. 14, 18 AND 25.

MASCO BATH CORPORATION, MOORESTOWN, NJ:
2,413,008, CANC. INT. CL. 11.
2,413,009, CANC. INT. CL. 11.

MASON, CHENG, SACRAMENTO, CA:
4,014,836, PUB. 6-7-2011. MULTIPLE CLASS, INT. CLS. 25
AND 41.

MASSACHUSETTS DEPARTMENT OF TRANSPORTA-
TION, BOSTON, MA:
4,014,382, PUB. 6-7-2011. MULTIPLE CLASS, INT. CLS. 9
AND 36.

MASSARELLI'S LAWN ORNAMENTS INC., HAMMON-
TON, NJ:
2,485,312, REN. 7-21-11. INT. CL. 19.

MASTER HAUS GROUP, ALAMO, CA:
4,015,143, PUB. 6-7-2011. INT. CL. 33.

MASUCCI, MATIAS, LOS ANGELES, CA:
4,016,992, INT. CL. 41.

MATCHBOX TWENTY, LLC, WEST HOLLYWOOD, CA:
2,563,699, REN. 7-15-11. INT. CL. 41.

MATERNAL CARE, INC., ALPHARETTA, GA:
2,911,652, CANC. INT. CL. 10.

MATHIS, YVETTE MARIAN, MARIETTA, GA:
2,911,027, CANC. INT. CL. 3.

MATSUSHITA ELECTRIC INDUSTRIAL CO., LTD., PRE-
FECTURE, JAPAN:
2,412,943, CANC. INT. CL. 6.

MATTEL, INC., EL SEGUNDO, CA:
2,413,177, CANC. INT. CL. 28.
2,591,947, REN. 7-21-11. INT. CL. 28.
2,592,993, REN. 7-21-11. INT. CL. 28.
2,911,587, CANC. INT. CL. 28.
4,016,582, INT. CL. 28.
4,016,716, INT. CL. 28.
4,016,883, INT. CL. 28.
4,016,996, INT. CL. 28.
4,017,013, INT. CL. 28.
4,017,014, INT. CL. 28.

MATTHEW BENDER & COMPANY, INCORPORATED,
WILMINGTON, DE:
1,690,138, REN. 7-15-11. INT. CL. 16.

MATTRESS FIRM, INC., HOUSTON, TX:
4,015,066, PUB. 6-7-2011. INT. CL. 35.

MAURER, WENDI, LA JOLLA, CA:
2,911,387, CANC. INT. CL. 16.

MAURICES INCORPORATED, DULUTH, MN:
4,014,773, PUB. 6-7-2011. INT. CL. 35.

MAVERICK CO PTY LTD, PORT MELBOURNE, AUSTRA-
LIA:
3,176,043, CANC. INT. CL. 25.

MAX CO., LTD., CHUO-KU TOKYO, JAPAN:
2,479,846, REN. 7-20-11. INT. CL. 7.

MAXIMA TECHNOLOGIES & SYSTEMS, LLC, LANCAS-
TER, PA:
2,911,026, CANC. INT. CL. 9.

MAXIMUM HUMAN PERFORMANCE, LLC, FAIRFIELD,
NJ:
4,016,060, PUB. 6-7-2011. INT. CL. 5.

MAY, DONALD R., SUN LAKES, AZ:
2,572,217, REN. 7-21-11. INT. CL. 6.

MAYBELLINE INTERMEDIATE CO., WILMINGTON, DE
TO L'OREAL USA CREATIVE, INC., NEW YORK, NY:
2,002,953, CANC. MULTIPLE CLASS, INT. CLS. 8, 16, 18,
21 AND 25.

MAYDAY PUBLISHING, INC., CAMARILLO, CA:
2,911,669, CANC. INT. CL. 9.

MAYO FOUNDATION FOR MEDICAL EDUCATION AND
RESEARCH, ROCHESTER, MN:
2,911,250, CANC. INT. CL. 16.

MAZE, STEPHANIE, POTOMAC, MD:
2,629,393, AM. INT. CL. 16.

MBOGORI, ERIC, ATLANTA, GA:
4,016,290, INT. CL. 41.

MCAF LLC, CINCINNATI, OH:
4,015,426, PUB. 6-7-2011. INT. CL. 35.

MCCABE, DENNIS, VIERA, FL AND MCCABE, PAULA,
VIERA, FL:
4,016,536, INT. CL. 35.

MCCLLENATHAN, STACEY LIESA, LIBERTYVILLE, IL,
DBA CLICKTHECOUP.COM:
4,015,098, PUB. 6-7-2011. INT. CL. 35.

MCCLURE, TIM, AUSTIN, TX:
2,496,620, REN. 7-16-11. MULTIPLE CLASS, INT. CLS. 25
AND 35.

MCCORMICK & MCCORMICK HOLDINGS LLC, DELTO-
NA, FL, DBA DOUBLE DIAMOND BASEBALL LEAGUE:
4,015,665, PUB. 6-7-2011. INT. CL. 41.

MCCRACKIN MOTORSPORTS, LLC, HARMONY, PA:
4,015,948, PUB. 6-7-2011. INT. CL. 35.

MCCUTCHEON ENTERPRISES INC., FAYETTE, MO:
2,911,275, CANC. INT. CL. 35.

MCDONNELL, JOANNE MARY, MELBOURNE, AUSTRA-
LIA, DBA JOMAX EQUINE PRODUCTS PTY LTD:
4,014,871, PUB. 6-7-2011. MULTIPLE CLASS, INT. CLS. 5
AND 31.

MCELLIGOTT, JACQUELINE, JACKSONVILLE, FL:
2,910,920, CANC. INT. CL. 35.

MCELROY MANUFACTURING, INC., TULSA, OK:
4,015,871, PUB. 6-7-2011. INT. CL. 7.
4,015,874, PUB. 6-7-2011. INT. CL. 7.
4,015,877, PUB. 6-7-2011. INT. CL. 7.

MCGOWAN, CORNELL, BROOKLYN, NY:
2,911,520, CANC. INT. CL. 41.

MCGRAW-HILL COMPANIES, INC., THE, NEW YORK, NY:
4,017,017, MULTIPLE CLASS, INT. CLS. 9 AND 16.

MCINTYRE, KEVIN M., BOSTON, MA:
2,910,955, CANC. INT. CL. 44.

MCKEAN & BURT, INC., WASHINGTON, PA, DBA ALL
WAYS MOVING & STORAGE:
4,015,760, PUB. 6-7-2011. INT. CL. 39.

MCKELLAR STRUCTURED SETTLEMENTS INC.,
GUELPH, ONTARIO, CANADA:
4,014,413, PUB. 6-7-2011. MULTIPLE CLASS, INT. CLS. 36
AND 45.
4,014,414, PUB. 6-7-2011. MULTIPLE CLASS, INT. CLS. 36
AND 45.

MCKENZIE ENTERPRISES, INC., MILWAUKEE, WI:
2,911,330, CANC. INT. CL. 25.

MCKESSON CORPORATION, SAN FRANCISCO, CA:
2,941,616, CANC. INT. CL. 21.

MCKISSACK III, JOHN B., VIDOR, TX:
4,017,088, INT. CL. 40.

MCMINNVILLE ACCESS COMPANY, MCMINNVILLE, OR:
2,910,768, CANC. INT. CL. 42.

MCNABB NUTRACEUTICALS, LLC, CHICAGO, IL:
4,014,897, PUB. 6-7-2011. INT. CL. 3.

MCNABB, MARK J., HUNTINGTON BEACH, CA:
2,412,375, CANC. INT. CL. 25.

MCQ ASSOCIATES, INC., FREDERICKSBURG, VA:
2,911,558, CANC. INT. CL. 9.

MCW LIMITED, KOWLOON,, HONG KONG:
4,016,731, INT. CL. 12.

MCWILLIAM'S WINES GROUP LTD, CHULLORA NSW
2190, AUSTRALIA:
4,014,682, PUB. 6-7-2011. INT. CL. 33.

MC21 CORPORATION, CAGUAS, PUERTO RICO:
4,016,434, INT. CL. 38.

MDI, INC., SAN ANTONIO, TX:
2,911,633, CANC. INT. CL. 9.

ME SOFTSOL, INC., WILMINGTON, CA:
2,910,557, CANC. INT. CL. 9.

ME TOO LLC, NEW YORK, NY:
4,017,230, INT. CL. 25.

MEADWESTVACO CORPORATION, STAMFORD, CT:
2,910,228, CANC. INT. CL. 41.
2,910,229, CANC. INT. CL. 16.

MEALEY'S FURNITURE HOLDINGS, INC., WARMIN-
STER, PA:
4,014,965, PUB. 6-7-2011. INT. CL. 35.

MECHANICAL DYNAMICS AND ANALYSIS, LTD., LA-
THAM, NY:
4,015,444, PUB. 6-7-2011. MULTIPLE CLASS, INT. CLS. 37
AND 42.

MECHANICAL NATURE, LLC, COLUMBIA, SC:
4,016,455, INT. CL. 14.

- MEDIAFOX, JERSEY CITY, NJ:
2,910,797, CANC. INT. CL. 35.
- MEDIALIVE INTERNATIONAL, INC., SAN FRANCISCO, CA:
2,910,436, CANC. MULTIPLE CLASS, INT. CLS. 16, 35 AND 41.
- MEDIATEK INC., HSINCHU, TAIWAN:
3,983,022, COR. MULTIPLE CLASS, INT. CLS. 9 AND 42.
- MEDICAL DIAGNOSTIC LABORATORIES, LLC, HAMILTON, NJ:
4,016,913, INT. CL. 42.
- MEDICAL RESEARCH COUNCIL, UNITED KINGDOM:
4,014,523, PUB. 6-7-2011. INT. CL. 10.
- MEDINRE, S.L., 08013 BARCELONA, SPAIN:
4,014,864, PUB. 6-7-2011. INT. CL. 33.
- MEDIPHARM CO., LTD., YOUNGDUNGPO-KU, SEOUL, REPUBLIC OF KOREA:
2,909,907, CANC. INT. CL. 44.
- MEDPACE LLC, CINCINNATI, OH:
2,468,517, REN. 7-19-11. INT. CL. 42.
- MEDTECH PRODUCTS INC., IRVINGTON, NY:
2,538,095, REN. 7-15-11. INT. CL. 5.
- MEETINGMETRICS, INC., NEW YORK, NY:
4,015,481, PUB. 6-7-2011. INT. CL. 35.
- MEISSNER MFG. CO., INC., CHATSWORTH, CA:
4,015,799, PUB. 6-7-2011. INT. CL. 11.
- MEKIS, THOMAS, WINSTON-SALEM, NC:
4,017,267, INT. CL. 36.
- MEKUS, JAMIE L., CHARLOTTE, NC:
2,461,557, REN. 7-16-11. INT. CL. 25.
- MELALEUCA, INC., IDAHO FALLS, ID:
4,015,269, PUB. 6-7-2011. INT. CL. 5.
- MELAN-INC., WHITTIER, CA:
2,910,712, CANC. INT. CL. 1.
- MELANIE P HILL, ATLANTA, GA:
4,014,377, PUB. 6-7-2011. INT. CL. 41.
- MELLI YELLOWPAGES, STUDIO CITY, CA:
4,014,718, PUB. 6-7-2011. INT. CL. 35.
- MELLO COMMUNICATIONS, LLC, NASHUA, NH:
4,016,241, INT. CL. 9.
- MELLOW BEVERAGE CO., LLC, ASPEN, CO:
4,014,330, PUB. 1-19-2010. INT. CL. 32.
4,014,331, PUB. 1-19-2010. INT. CL. 32.
- MELVIN N.A. AVANZADO, LOS ANGELES, CA, DBA THE AVANZADO LAW FIRM:
4,015,965, PUB. 6-7-2011. INT. CL. 45.
- MEMBERS COOPERATIVE CREDIT UNION, CLOQUET, MN:
4,015,613, PUB. 6-7-2011. INT. CL. 36.
- MEMBERS FIRST FEDERAL CREDIT UNION, LOUISVILLE, KY:
2,910,291, CANC. INT. CL. 36.
- MEMEC GROUP LIMITED, THAME, UNITED KINGDOM:
2,910,875, CANC. INT. CL. 42.
- MEMRY CORPORATION, BETHEL, CT:
2,911,789, CANC. INT. CL. 6.
- MENDEZ OLIVETO, EVELYN, SHERMAN OAKS, CA AND OLIVETO, LEONARDO A., SHERMAN OAKS, CA:
4,016,584, INT. CL. 25.
- MENTOR GRAPHICS CORPORATION, WILSONVILLE, OR:
4,017,212, INT. CL. 9.
- MERAMEC GROUP, INC., SULLIVAN, MO:
2,574,031, REN. 7-16-11. INT. CL. 25.
- MERCHANTTEER, INC., WILLIAMSPORT, MD:
4,015,821, PUB. 6-7-2011. INT. CL. 14.
- MERCK KGAA, DARMSTADT 64293, FED REP GERMANY, MERCK, E., 61 DARMSTADT, FED REP GERMANY:
912,021, REN. 7-20-11. U.S. CL. 6 (INT. CL. 1).
- MERCY MEDICAL AIRLIFT, VIRGINIA BEACH, VA:
4,017,121, INT. CL. 39.
- MEREDITH CORPORATION, DES MOINES, IA:
4,016,240, INT. CL. 2.
- MERIDIAN BEHAVIORAL HEALTH, LLC, NEW BRIGHTON, MN:
4,017,153, INT. CL. 44.
- MERLIN CORPORATION, GENEVA, IL:
2,578,539, REN. 7-15-11. INT. CL. 37.
- MERQUINSA MERCADOS QUIMICOS S.L., 08160 MONTELO (BARCELONA), SPAIN:
2,471,844, REN. 7-15-11. INT. CL. 1.
- MESO US TRADEMARK LTD., MISSISSAUGA, ONTARIO, CANADA:
2,910,798, CANC. INT. CL. 5.
- META PHARMACEUTICAL SERVICES, BLUE BELL, PA:
4,016,611, MULTIPLE CLASS, INT. CLS. 9 AND 42.
4,016,613, MULTIPLE CLASS, INT. CLS. 9 AND 42.
4,016,614, MULTIPLE CLASS, INT. CLS. 9 AND 42.
4,016,615, MULTIPLE CLASS, INT. CLS. 9 AND 42.
4,016,619, MULTIPLE CLASS, INT. CLS. 9 AND 42.
4,016,620, INT. CL. 42.
- METABANK, SIOUX FALLS, SD:
4,015,556, PUB. 6-7-2011. INT. CL. 36.
4,016,525, INT. CL. 36.
- METADIGM SERVICES, INC., COVINGTON, GA:
4,015,991, PUB. 6-7-2011. INT. CL. 37.
- METAL RABBIT MEDIA LLC, NEW YORK, NY:
4,015,770, PUB. 6-7-2011. INT. CL. 35.
- METALLIX DIRECT GOLD, LLC, SHREWSBURY, NJ:
4,016,732, INT. CL. 35.
- METALLURGY, LLC, SAN FRANCISCO, CA:
4,016,002, PUB. 6-7-2011. INT. CL. 14.
- METAOR-METAL INJECTION INDUSTRIES LTD., MIZRA 19312, ISRAEL:
2,911,451, CANC. INT. CL. 40.
- MEWETT PROPERTY PTY LTD, TOMAGO NSW 2322, AUSTRALIA:
4,014,472, PUB. 6-7-2011. MULTIPLE CLASS, INT. CLS. 11 AND 19.
- MEXICO FOODS, LLC, HOUSTON, TX:
4,017,188, INT. CL. 30.
- MGA ENTERTAINMENT, INC., VAN NUYS, CA:
2,412,775, CANC. INT. CL. 28.
2,911,097, CANC. INT. CL. 28.
- MIAMI FOUNDATION, INC., THE, MIAMI, FL:
4,014,227, PUB. 6-7-2011. INT. CL. 36.
- MICHAEL CARTER, FEDERAL WAY, WA:
4,015,922, PUB. 6-7-2011. INT. CL. 9.
- MICHAEL GUEN, SEDONA, AZ:
2,909,419, CANC. MULTIPLE CLASS, INT. CLS. 9, 16 AND 41.
- MICHAEL HAYNES PLC, KESWICK, VA:
4,017,208, INT. CL. 45.
- MICHAEL JOHN WARD, WARWICKSHIRE, UNITED KINGDOM:
4,015,080, PUB. 6-7-2011. INT. CL. 16.
- MICHAEL NITTEL, UPLAND, CA, DBA DEALERS INC.:
4,016,325, INT. CL. 25.
- MICHAELS, CHRISTIAN, SAN DIEGO, CA:
2,911,815, CANC. MULTIPLE CLASS, INT. CLS. 16 AND 41.
- MICHELE ABBUHL, BOCA RATON, FL:
4,014,882, PUB. 6-7-2011. MULTIPLE CLASS, INT. CLS. 35 AND 39.
4,014,893, PUB. 6-7-2011. MULTIPLE CLASS, INT. CLS. 35 AND 39.
- MICHIGAN SILVER SPRINGS, LLC, SPRING LAKE, MI:
2,911,420, CANC. INT. CL. 1.
- MICHIGAN VIRTUAL UNIVERSITY, LANSING, MI:
2,468,992, REN. 7-18-11. INT. CL. 41.
- MICROLIFE INTELLECTUAL PROPERTY GMBH, SWITZERLAND:
4,014,536, PUB. 6-7-2011. MULTIPLE CLASS, INT. CLS. 36 AND 41.
- MICROSENSE HOLDINGS LLC, BURLINGTON, MA:
2,413,259, CANC. INT. CL. 9.
- MICROWORLD TECHNOLOGIES, INC., FARMINGTON HILLS, MI:
4,016,949, INT. CL. 9.
- MIDWEST INDUSTRIAL SUPPLY, INC., CANTON, OH:
4,017,080, INT. CL. 1.
- MIDWESTERN INDUSTRIES, INC., MASSILLON, OH:
2,591,496, REN. 7-21-11. INT. CL. 7.
- MIGHTY LEAF TEA, SAN RAFAEL, CA:
2,544,636, REN. 7-18-11. INT. CL. 30.

MIGHTY OATS, INC., TEMECULA, CA:
2,911,784, CANC. MULTIPLE CLASS, INT. CLS. 30 AND 31.

MIKE DALE JEWELERS, INC., MANDEVILLE, LA:
4,017,007, INT. CL. 14.

MIKE MORAN GROUP, LLC, PARAMUS, NJ:
4,015,883, PUB. 6-7-2011. INT. CL. 35.

MILAZZO INDUSTRIES INC., PITTSSTON, PA, MILAZZO INDUSTRIES INC., PITTSSTON, PA:
1,647,134, REN. 7-19-11. MULTIPLE CLASS, INT. CLS. 1, 3 AND 4.

MILBON CO., LTD., OSAKA, JAPAN:
4,014,701, PUB. 6-7-2011. INT. CL. 3.

MILDARA BLASS, INC., SANTA ROSA, CA, DBA WINDSOR VINEYARDS:
4,015,602, PUB. 6-7-2011. INT. CL. 33.

MILES-BRAMWELL EXECUTIVE SERVICES LIMITED, ALFRETON, DERBYSHIRE, GREAT BRITAIN:
4,014,313, PUB. 11-30-2010. MULTIPLE CLASS, INT. CLS. 16, 41 AND 44.

MILES, ELIZABETH, NEW PRESTON, CT:
2,910,936, CANC. INT. CL. 16.

MILITARY ORDER OF THE PURPLE HEART SERVICE FOUNDATION, INC., ANNANDALE, VA:
4,015,788, PUB. 6-7-2011. INT. CL. 36.

MILITTI SALES & PROMOTIONS, LLC, OMAHA, NE:
4,015,774, PUB. 6-7-2011. INT. CL. 9.

MILKBOY COFFEE, LLC, PHILADELPHIA, PA:
4,016,027, PUB. 6-7-2011. INT. CL. 43.

MILLENIA JEWELERS, LLC, ORLANDO, FL:
2,910,290, CANC. INT. CL. 35.

MILLENNIAL LIVING INC., ARLINGTON, VA, AKA MILLENNIALLIVING.COM:
4,015,363, PUB. 6-7-2011. INT. CL. 41.

MILLENNIUM INTERNATIONAL DEVELOPMENT CORPORATION, BOCA RATON, FL:
2,412,998, CANC. INT. CL. 20.

MILLSTEIN, MITCHELL A., CHESTERFIELD, MO:
2,412,085, CANC. INT. CL. 42.
2,412,087, CANC. INT. CL. 42.

MIMEDX GROUP, INC., MARIETTA, GA:
4,017,234, INT. CL. 5.

MINDFLO LLC, LOS ANGELES, CA:
4,015,954, PUB. 6-7-2011. INT. CL. 45.

MINISTERO DELLE POLITICHE AGRICOLE, ALIMENTARI E FORESTALI - DIPARTIMENTO DELLE POLITICHE COMPETITIVE DEL MONDO RURALE E DELLA QUALITA' - DIREZIONE GENERALE PER LO SVILUPPO AGROALIMENTARE LA QUALITA' E LA TUTELA DEL CONSUMATORE, ITALY:
4,014,500, PUB. 6-7-2011. INT. CL. 29.

MINISTERO DELLE POLITICHE AGRICOLE, ALIMENTARI E FORESTALI -; DIPARTIMENTO DELLE POLITICHE; COMPETITIVE DEL MONDO RURALE; E DELLA QUALITA' -; DIREZIONE GENERALE PER LO SVILUPPO AGROALIMENTARE,; LA QUALITA' E LA TUTELA; DEL CONSUMATORE, ROMA, ITALY:
4,014,499, PUB. 6-7-2011. INT. CL. 29.

MINISTERO DELLE POLITICHE AGRICOLE, ALIMENTARI E FORESTALI -; DIPARTIMENTO DELLE POLITICHE; COMPETITIVE DEL MONDO RURALE; E DELLA QUALITA' -; DIREZIONE GENERALE PER LO SVILUPPO AGROALIMENTARE,; LA QUALITA' E LA TUTELA; DEL CONSUMATORE, ITALY:
4,014,504, PUB. 6-7-2011. INT. CL. 31.
4,014,505, PUB. 6-7-2011. INT. CL. 31.

MINUS ZERO, IRVINE, CA, DBA 360 INFLUENCE LLC:
4,016,819, INT. CL. 41.

MINYANVILLE PUBLISHING & MULTIMEDIA, LLC, NEW YORK, NY:
4,014,829, PUB. 6-7-2011. INT. CL. 41.

MIRAGE RESORTS, INCORPORATED, LAS VEGAS, NV:
2,910,231, CANC. INT. CL. 44.
2,911,549, CANC. INT. CL. 32.

MISSION INFORMATION RESOURCES, INC., LANCASTER, NH:
4,017,415, INT. CL. 16.

MISSISSIPPI BAND OF CHOCTAW INDIANS, CHOCTAW, MS:
4,016,139, PUB. 6-7-2011. MULTIPLE CLASS, INT. CLS. 41 AND 43.

MISSISSIPPI RIVER DISTILLING COMPANY, LECLAIRE, IA:
4,017,131, INT. CL. 33.

MISSISSIPPI STATE UNIVERSITY, MISSISSIPPI STATE, MS:
4,016,153, INT. CL. 32.

MISSOURI CARDIOVASCULAR SPECIALISTS, L.L.P., COLUMBIA, MO:
2,586,995, REN. 7-15-11. INT. CL. 42.

MISSOURI HOSPITAL ASSOCIATION, JEFFERSON CITY, MO:
4,017,160, INT. CL. 42.

MISTRAS GROUP, INC., PRINCETON JUNCTION, NJ:
4,014,826, PUB. 6-7-2011. INT. CL. 9.

MITCH SPINACH PRODUCTIONS INC., CORAL SPRINGS, FL:
4,015,017, PUB. 6-7-2011. INT. CL. 16.

MITCHELL, CRAIG, RANSOM CANYON, TX:
4,015,125, PUB. 6-7-2011. INT. CL. 4.

MITCHELL, ROBERT V., PITTSBURGH, PA:
2,494,936, CANC. INT. CL. 36.

MITEK SYSTEMS, INC., SAN DIEGO, CA:
2,586,378, REN. 7-20-11. INT. CL. 9.

MLB ADVANCED MEDIA, L.P., NEW YORK, NY:
4,016,087, PUB. 6-7-2011. MULTIPLE CLASS, INT. CLS. 9 AND 35.
4,016,130, PUB. 6-7-2011. MULTIPLE CLASS, INT. CLS. 38, 41 AND 45.

MMRGLOBAL, INC., LOS ANGELES, CA:
4,015,029, PUB. 6-7-2011. INT. CL. 39.

MOBI MUNCH, CARSON CITY, NV:
4,016,573, MULTIPLE CLASS, INT. CLS. 35, 38, 39, 42 AND 43.

MOBI MUNCH, INC., CARSON CITY, NV:
4,016,460, MULTIPLE CLASS, INT. CLS. 35, 39, 42 AND 43.

MOBILE CENTREX, INC., RICHARDSON, TX:
2,911,464, CANC. INT. CL. 9.

MOBILE PAINT MFG. CO. INC. (DEL. CORP.), THEODORE, AL:
392,063, REN. 7-18-11. U.S. CL. 16 (INT. CL. 2).

MODERN SURREALIST LLC, WINFIELD, IL:
4,014,376, PUB. 6-7-2011. INT. CL. 16.

MODULAR WETLAND SYSTEMS, INC., OCEANSIDE, CA:
4,015,294, PUB. 6-7-2011. INT. CL. 11.
4,015,295, PUB. 6-7-2011. INT. CL. 11.

MOEDA LIVING, INC., ATLANTA, GA:
4,014,263, PUB. 6-7-2011. INT. CL. 20.

MOLDED FIBER GLASS COMPANIES, ASHTABULA, OH:
4,015,511, PUB. 6-7-2011. MULTIPLE CLASS, INT. CLS. 37, 40 AND 42.

MOLLISON, MATHEW B, BELOIT, WI, DBA XCLUSIVE RYDERS:
4,014,860, PUB. 6-7-2011. INT. CL. 25.

MOMMY DOCTORS BAKERY, THE, ROANOKE, VA:
4,016,734, INT. CL. 30.

MONCLER S.R.L., MILANO, ITALY:
2,464,682, REN. 7-18-11. INT. CL. 25.

MONEY MISSION, LLC, MILWAUKEE, WI:
4,016,725, MULTIPLE CLASS, INT. CLS. 9, 16, 18, 21, 25 AND 41.

MONJELLO, DONALD, LONG BEACH, NY AND MONJELLO, JEFFREY, LONG BEACH, NY:
4,015,136, PUB. 6-7-2011. INT. CL. 20.

MONKEY MUFFINS, INC., NYACK, NY:
2,909,537, CANC. INT. CL. 30.

MOO THRU LLC, REMINGTON, VA:
4,014,932, PUB. 6-7-2011. INT. CL. 30.

MOO-MOO'S YOGURT BAR, INC., GREENBRIAR, AR:
4,015,344, PUB. 6-7-2011. INT. CL. 35.

MOODY GARDENS, INC., GALVESTON, TX:
2,580,665, REN. 7-19-11. INT. CL. 41.

MOORE AND MOORE BUILDERS, INC., ST. JOHN, IN:
4,015,935, PUB. 6-7-2011. INT. CL. 19.

- MOORE LIFE MINISTRIES, INC., BROKEN ARROW, AR:
2,412,379, CANC. MULTIPLE CLASS, INT. CLS. 9 AND 16.
- MOORE, JACQUELINE, BOYNTON BEACH, FL:
4,015,595, PUB. 6-7-2011. INT. CL. 30.
- MOORE, MINYON, WASHINGTON, DC:
4,016,402, MULTIPLE CLASS, INT. CLS. 35, 41, 42 AND 45.
- MOOSE MOUNTAIN TOYMAKERS LTD., TSIMSHATSUI EAST, KOWLOON, HONG KONG:
2,412,918, CANC. INT. CL. 28.
- MOOSETACHE GAMES, LLC, BERKELEY, CA:
4,017,228, INT. CL. 28.
- MORI SEIKI CO., LTD., NARA, JAPAN:
4,014,296, PUB. 4-19-2011. INT. CL. 7.
- MORRIS FLAMINGO - STEPHAN, INC., FORT LAUDERDALE, FL, FLAMINGO PRODUCTS, INC., DANVILLE, IL:
546,374, REN. 7-21-11. U.S. CL. 39 (INT. CL. 26).
- MORRIS NATIONAL, INC., AZUSA, CA:
4,016,359, INT. CL. 30.
- MORRIS, JIM, LOS ANGELES, CA:
2,911,595, CANC. INT. CL. 41.
- MORRISON MANAGEMENT SPECIALISTS, INC., ATLANTA, GA:
4,016,443, MULTIPLE CLASS, INT. CLS. 35 AND 44.
- MORRISON, CINDY W, TULSA, OK:
4,015,566, PUB. 6-7-2011. MULTIPLE CLASS, INT. CLS. 16 AND 41.
- MORRISON, KRISTIN LYNN, SAN RAFAEL, CA:
4,016,006, PUB. 6-7-2011. INT. CL. 45.
- MORTGAGE CADENCE, LLC, DENVER, CO:
4,015,273, PUB. 6-7-2011. INT. CL. 42.
- MORTON'S OF CHICAGO, INC., CHICAGO, IL:
1,647,093, REN. 7-19-11. INT. CL. 42.
- MOTION PICTURE ASSOCIATION OF AMERICA, INC., ENCINO, CA:
1,169,742, REN. 7-15-11. U.S. CL. B.
1,169,743, REN. 7-15-11. U.S. CL. B.
- MOTOROLA TRADEMARK HOLDINGS, LLC, LIBERTYVILLE, IL:
717,485, REN. 7-21-11. U.S. CL. 21 (INT. CLS. 7, 9, 11, 12 AND 15).
4,016,260, INT. CL. 9.
4,017,031, INT. CL. 9.
- MOTRICITY, INC., BELLEVUE, WA:
2,910,788, CANC. MULTIPLE CLASS, INT. CLS. 9 AND 38.
- MOUNT FRANKLIN FOODS, LLC, EL PASO, TX:
4,015,787, PUB. 6-7-2011. INT. CL. 29.
- MOUNTAIN QUEST INSTITUTE LLC, MARLINTON, WV:
4,015,522, PUB. 6-7-2011. INT. CL. 16.
- MOUNTAINSIDE SOFTWARE, INC., WEYERS CAVE, VA:
2,412,217, CANC. INT. CL. 9.
- MOVING TALES, INC., GIBSONS, BC, CANADA:
4,015,034, PUB. 6-7-2011. INT. CL. 9.
- MOYER, FRED, LEE, NH:
2,412,646, CANC. INT. CL. 9.
- MPB SOLUTIONS, INC., EVERGREEN PARK, IL:
2,470,570, REN. 7-15-11. INT. CL. 11.
- MR DEREK MCMINN, UNITED KINGDOM:
4,014,620, PUB. 6-7-2011. INT. CL. 10.
- MR. CHOW ENTERPRISES, LTD., BEVERLY HILLS, CA:
1,160,402, REN. 7-19-11. INT. CL. 42.
- MR. STICKY'S, INC, ANTES FORT, PA:
4,015,377, PUB. 6-7-2011. INT. CL. 30.
- MST INFINITY, INC., PHOENIX, AZ:
4,016,780, INT. CL. 25.
- MTD PRODUCTS INC., VALLEY CITY, OH, GARDEN WAY INCORPORATED, TROY, NY:
1,645,805, REN. 7-20-11. INT. CL. 7.
- MUELLER INDUSTRIES, INC., MEMPHIS, TN, MUELLER BRASS CO., PORT HURON, MI:
718,553, REN. 7-19-11. U.S. CL. 31 (INT. CL. 11).
- MULTI-HOLDING AG, CH-4123 ALLSCHWIL, SWITZERLAND:
4,014,559, PUB. 6-7-2011. INT. CL. 9.
- MULTIBLITZ USA, BALTIMORE, MD, TA MULTIBLITZ USA:
4,015,709, PUB. 6-7-2011. INT. CL. 11.
- MULTIPLE CHOICES PHOTOGRAPHY LLC, WEST BLOOMFIELD, MI:
4,015,304, PUB. 6-7-2011. INT. CL. 9.
- MULTIPLEX PROPERTIES, INC., WILMINGTON, DE:
4,017,185, INT. CL. 41.
- MULTISORB TECHNOLOGIES, INC., BUFFALO, NY:
4,015,526, PUB. 6-7-2011. INT. CL. 1.
- MURATA KIKAI KABUSHIKI KAISHA, KYOTO-SHI, JAPAN:
2,910,678, CANC. INT. CL. 7.
- MURGITROYD & COMPANY, GLASGOW, UNITED KINGDOM:
4,014,411, PUB. 6-7-2011. MULTIPLE CLASS, INT. CLS. 9, 16, 35, 41, 42 AND 45.
- MURILLO, ALFONSO, GLEN CARBON, IL, DBA MURILLO TRADING COMPANY:
2,911,240, CANC. INT. CL. 30.
- MURPHY, JAMES V, CHICAGO, IL:
4,014,971, PUB. 6-7-2011. INT. CL. 42.
- MUSEUM PRODUCTS, INC., MYSTIC, CT:
2,910,017, CANC. INT. CL. 35.
- MUSEUM TOWER, LP, DALLAS, TX:
4,015,063, PUB. 6-7-2011. INT. CL. 37.
4,015,064, PUB. 6-7-2011. INT. CL. 35.
- MUTASIAN MEDIA, LLC, PALM BEACH GARDENS, FL:
4,016,267, INT. CL. 16.
- MUZO INTERNATIONAL LTD., GRAND CAYMAN, CAYMAN ISLANDS:
4,016,593, INT. CL. 14.
- MVP GROUP INTERNATIONAL, INC., CHARLESTON, SC:
4,015,380, PUB. 6-7-2011. INT. CL. 4.
- MW INDUSTRIES, INC., LOGANSPOUT, IN:
2,412,027, CANC. INT. CL. 6.
- MWR HOLDINGS, LLC, BOCA RATON, FL:
4,016,585, INT. CL. 43.
- MY DIAMOND PLACE, LTD., NASSAU, BAHAMAS:
4,016,480, INT. CL. 14.
- MY ENOLOGIST, INC., NAPA, CA:
4,015,118, PUB. 6-7-2011. INT. CL. 42.
- MY VENUE SOURCE LLC., BILLINGS, MT:
4,015,370, PUB. 6-7-2011. INT. CL. 42.
- MY WELLNESS SUMMIT, INC., HIGHLAND PARK, IL:
4,015,597, PUB. 6-7-2011. INT. CL. 44.
- MYCORPORATION BUSINESS SERVICES, INC., CALABASAS, CA, DBA MYCORPORATION.COM:
2,909,866, CANC. INT. CL. 16.
- MYMEDICALRECORDS, INC., LOS ANGELES, CA:
4,015,173, PUB. 6-7-2011. INT. CL. 39.
4,015,174, PUB. 6-7-2011. INT. CL. 39.
- MYSTIC SEAPORT MUSEUM, INC., MYSTIC, CT, AKA MYSTIC SEAPORT MUSEUM STORES, INC.:
1,160,355, REN. 7-16-11. MULTIPLE CLASS, INT. CLS. 41 AND 42.
- MYSTIC SEAPORT MUSEUM, INC., MYSTIC, CT:
2,459,354, REN. 7-20-11. INT. CL. 32.
- MYSTIC VALLEY TRADERS LLC, WOBURN, MA:
2,910,681, CANC. INT. CL. 24.
- MYVBO, PETERBOROUGH, NH:
4,015,734, PUB. 6-7-2011. INT. CL. 35.
- MYWALIT.COM S.R.L., ITALY:
4,014,470, PUB. 6-7-2011. MULTIPLE CLASS, INT. CLS. 18, 24 AND 25.
- MYX, INC., PALM SPRINGS, CA:
4,016,993, INT. CL. 20.
4,016,994, INT. CL. 16.
- NADHARI S. A. DE C.V., MÉXICO D.F., MEXICO:
4,017,053, MULTIPLE CLASS, INT. CLS. 9, 36 AND 38.
- NAMCO BANDAI GAMES INC., TOKYO 140-8590, JAPAN:
4,016,583, INT. CL. 9.
- NAME RITE, L.L.C., TEMECULA, CA:
4,017,266, MULTIPLE CLASS, INT. CLS. 11 AND 17.
- NANETTE RUBEN LLC, FRISCO, TX, DBA NANETTE RUBEN:
4,017,138, INT. CL. 14.

- NANOPASS TECHNOLOGIES, LTD., PARK HA'MADA NES-ZIONA, ISRAEL:
4,016,219, INT. CL. 10.
- NAPO, INC., MOUNT LAUREL, NJ, NATIONAL ASSOCIATION OF PROFESSIONAL ORGANIZERS, INC.:
3,044,932, COR. INT. CL. 35.
- NASHVILLE SURGICAL INSTRUMENTS, SPRINGFIELD, TN:
4,014,781, PUB. 6-7-2011. INT. CL. 10.
- NASTASI, KATHLEEN T., AMAGANSETT, NY:
4,014,855, PUB. 6-7-2011. INT. CL. 25.
- NASUNI CORPORATION, NATICK, MA:
4,016,415, MULTIPLE CLASS, INT. CLS. 9, 38 AND 42.
- NATAL SHARKS BOARD, KWA-ZULU NATAL, SOUTH AFRICA:
2,420,356, REN. 7-20-11. INT. CL. 9.
- NATIONAL ASSOCIATION FOR THE SPECIALTY FOOD TRADE, INC., NEW YORK, NY:
2,910,106, CANC. MULTIPLE CLASS, INT. CLS. 35 AND 41.
- NATIONAL ASSOCIATION OF CONVENIENCE STORES, ALEXANDRIA, VA:
4,017,405, INT. CL. 35.
- NATIONAL ASSOCIATION OF INSURANCE AND FINANCIAL ADVISORS, FALLS CHURCH, VA, NATIONAL ASSOCIATION OF INSURANCE AND FINANCIAL ADVISORS, FALLS CHURCH, VA:
2,545,750, REN. 7-18-11. INT. CL. 16.
- NATIONAL ASSOCIATION OF INVESTORS CORPORATION, MADISON HEIGHTS, MI:
2,469,197, REN. 7-20-11. INT. CL. 41.
- NATIONAL ASSOCIATION OF RESIDENTIAL PROPERTY MANAGERS, VIRGINIA BEACH, VA:
2,591,664, REN. 7-20-11. U.S. CL. B.
- NATIONAL ASSOCIATION OF STATE RETIREMENT ADMINISTRATORS, NEW ORLEANS, LA:
4,015,071, PUB. 6-7-2011. MULTIPLE CLASS, INT. CLS. 9, 16 AND 41.
- NATIONAL AUDUBON SOCIETY, INC., NEW YORK, NY:
4,015,510, PUB. 6-7-2011. INT. CL. 9.
- NATIONAL ELECTRICAL MANUFACTURERS ASSOCIATION, ROSSLYN, VA:
4,016,285, MULTIPLE CLASS, INT. CLS. 35, 38 AND 41.
- NATIONAL ELECTRONICS WARRANTY, LLC, STERLING, VA:
4,016,631, MULTIPLE CLASS, INT. CLS. 35, 36, 37, 41 AND 42.
- NATIONAL FEDERATION OF INDIAN-AMERICAN ASSOCIATIONS, INC., GAITHERSBURG, MD:
2,411,943, CANC. INT. CL. 42.
- NATIONAL FIREFIGHTER SKI RACES, DENVER, CO:
4,015,129, PUB. 6-7-2011. INT. CL. 36.
- NATIONAL FOOTBALL FOUNDATION AND COLLEGE HALL OF FAME, INC., THE, IRVING, TX:
2,480,063, REN. 7-16-11. MULTIPLE CLASS, INT. CLS. 41 AND 42.
- NATIONAL GEOGRAPHIC SOCIETY, WASHINGTON, DC:
2,456,938, REN. 7-18-11. INT. CL. 16.
2,457,756, REN. 7-19-11. INT. CL. 38.
- NATIONAL GYPSUM PROPERTIES, LLC, CHARLOTTE, NC, NATIONAL GYPSUM PROPERTIES, CHARLOTTE, NC:
2,478,854, REN. 7-18-11. INT. CL. 16.
- NATIONAL HOT ROD ASSOCIATION, GLENDORA, CA:
2,911,666, CANC. INT. CL. 41.
2,911,703, CANC. INT. CL. 41.
- NATIONAL HOT ROD ASSOCIATION, GLENDORA, CA, DBA NHRA:
4,014,261, PUB. 6-7-2011. INT. CL. 25.
- NATIONAL HOUSING & REHABILITATION ASSOCIATION, WASHINGTON, DC:
2,587,855, REN. 7-19-11. INT. CL. 42.
- NATIONAL INSTITUTE OF CERTIFIED ESTATE PLANNERS, KOKOMO, IN:
2,126,710, CANC. INT. CL. 41.
- NATIONAL MONEY LLC, BOCA RATON, FL:
4,017,012, INT. CL. 35.
- NATIONAL NETWORK OF DIGITAL SCHOOLS MANAGEMENT FOUNDATION, BEAVER, PA:
4,014,933, PUB. 6-7-2011. INT. CL. 41.
- NATIONAL PORK PRODUCERS COUNCIL, URBANDALE, IA:
4,015,963, PUB. 6-7-2011. INT. CL. 35.
- NATIONAL RIFLE ASSOCIATION OF AMERICA, FAIRFAX, VA:
2,590,696, REN. 7-19-11. INT. CL. 42.
- NATIONAL SCRIP CENTER, INC., SANTA ROSA, CA:
2,911,186, CANC. INT. CL. 36.
- NATIONAL SEMICONDUCTOR CORPORATION, SANTA CLARA, CA:
2,911,087, CANC. INT. CL. 42.
- NATIONAL SHOOTING SPORTS FOUNDATION, INC., NEWTOWN, CT:
2,413,100, CANC. INT. CL. 42.
- NATIONAL SLEEP FOUNDATION, WASHINGTON, DC:
2,413,306, CANC. INT. CL. 42.
- NATIONAL STROKE ASSOCIATION, CENTENNIAL, CO:
4,015,584, PUB. 6-7-2011. INT. CL. 35.
- NATIONAL TRUST FOR HISTORIC PRESERVATION IN THE UNITED STATES, WASHINGTON, DC:
2,910,512, CANC. INT. CL. 41.
- NATISA S.A., BARQUISIMETO, VENEZUELA:
1,646,771, REN. 7-15-11. INT. CL. 12.
- NATREN INC., WESTLAKE VILLAGE, CA:
2,911,557, CANC. INT. CL. 5.
- NATURAL POOL PRODUCTS, INC., MCKINNEY, TX:
4,017,410, INT. CL. 1.
- NATUREPLEX, LLC, MEMPHIS, TN:
4,015,054, PUB. 6-7-2011. INT. CL. 5.
4,015,156, PUB. 6-7-2011. INT. CL. 5.
- NAVA, DONALD E., LOS ALTOS, CA:
2,412,365, CANC. INT. CL. 41.
- NAVICO INTERNATIONAL LIMITED, ST. HELIER, CHANNEL ISLANDS, JERSEY:
2,910,402, CANC. INT. CL. 9.
- NAVIMA CALZADOS, S.L., VALENCIA, SPAIN:
4,015,184, PUB. 6-7-2011. INT. CL. 25.
- NAVTRONICS LLC, YORK, ME:
2,478,540, REN. 7-18-11. INT. CL. 35.
- NBC FOURTH REALTY CORP., NORTH LAS VEGAS, NV:
2,486,445, REN. 7-18-11. MULTIPLE CLASS, INT. CLS. 3 AND 28.
- NCH CORPORATION, IRVING, TX, NATIONAL CHEMSEARCH CORPORATION, IRVING, TX:
920,855, REN. 7-20-11. U.S. CL. 52 (INT. CL. 3).
- NCS COLOUR AKTIEBOLAG, SE-100 28 STOCKHOLM, SWEDEN:
4,014,759, PUB. 6-7-2011. MULTIPLE CLASS, INT. CLS. 2, 9, 16, 24 AND 42.
- NDB DIRECT, LLC, JESSUP, MD:
2,412,321, CANC. INT. CL. 35.
- NEAL'S YARD (NATURAL REMEDIES) LIMITED, LONDON, UNITED KINGDOM:
4,014,327, PUB. 6-7-2011. MULTIPLE CLASS, INT. CLS. 3, 5, 9, 16, 29, 30, 31, 35, 41, 43 AND 44.
- NEATO ROBOTICS, INC., MOUNTAIN VIEW, CA:
4,016,401, INT. CL. 9.
- NEBRASKA BOOK COMPANY, INC., LINCOLN, NE:
4,016,137, PUB. 6-7-2011. INT. CL. 35.
- NECTAR, INC., LONG BEACH, CA:
4,016,848, INT. CL. 11.
- NEDERLANDER ORGANIZATION, INC., NEW YORK, NY:
4,017,372, MULTIPLE CLASS, INT. CLS. 9 AND 41.
- NEENAH GESSNER GMBH, FED REP GERMANY:
4,014,461, PUB. 6-7-2011. MULTIPLE CLASS, INT. CLS. 11, 16 AND 17.
- NEENAH PAPER, INC., ALPHARETTA, GA:
2,468,331, REN. 7-18-11. INT. CL. 16.
- NEIGHBORE CARE HOLDINGS, INC., COVINGTON, KY:
2,909,457, CANC. INT. CL. 35.
- NEILL CORPORATION, HAMMOND, LA:
2,498,159, REN. 7-20-11. INT. CL. 35.
- NEKUTLI SA DE CV, CUQUÍO, JALISCO, MEXICO:
4,014,973, PUB. 6-7-2011. INT. CL. 29.

- NEO-FLO, INC., KENNESAW, GA, DBA MICROCOPY:
4,017,201, INT. CL. 10.
- NET TALK.COM, INC., NORTH MIAMI BEACH, FL:
4,016,067, PUB. 6-7-2011. INT. CL. 9.
- NETGEAR, INC., SAN JOSE, CA:
4,016,362, INT. CL. 9.
- NETWORK ASSOCIATES, INC., MT. PLEASANT, SC, MUL-
TIPLE LISTING NETWORK INC., CHARLESTON, SC:
1,652,070, REN. 7-21-11. INT. CL. 36.
- NETWORK SOLUTIONS, LLC, HERNDON, VA, VERISIGN,
INC., DULLES, VA:
2,549,368, REN. 7-16-11. MULTIPLE CLASS, INT. CLS. 38
AND 42.
- NETWORK STABILITY, INC., BOCA RATON, FL:
2,910,643, CANC. INT. CL. 42.
- NEUBERGER BERMAN MANAGEMENT LLC, NEW
YORK, NY:
2,468,285, REN. 7-19-11. INT. CL. 36.
4,015,324, PUB. 6-7-2011. INT. CL. 36.
4,015,325, PUB. 6-7-2011. INT. CL. 36.
4,015,326, PUB. 6-7-2011. INT. CL. 36.
- NEVIS INDUSTRIES LLC, WILMINGTON, DE:
4,016,312, MULTIPLE CLASS, INT. CLS. 6 AND 12.
- NEVITT, BRYANT D., ANAHEIM, CA:
2,911,189, CANC. INT. CL. 25.
- NEW ASIA, INC., SAN GABRIEL, CA:
2,909,946, CANC. INT. CL. 20.
- NEW B.C.N. TRADING INC., SOUTH PLAINFIELD, NJ:
4,015,537, PUB. 6-7-2011. MULTIPLE CLASS, INT. CLS. 29
AND 30.
- NEW BELGIUM BREWING COMPANY, INC., FORT COL-
LINS, CO:
4,016,915, MULTIPLE CLASS, INT. CLS. 16, 25 AND 32.
- NEW BRAND VISION LIMITED, STANMORE, MIDDLE-
SEX, UNITED KINGDOM:
4,015,045, PUB. 6-7-2011. MULTIPLE CLASS, INT. CLS. 9,
16, 38, 41 AND 42.
- NEW CONCEPTS DEVELOPMENT CORPORATION,
WOODSTOCK, IL:
4,016,649, INT. CL. 9.
- NEW CONCEPTS DEVELOPMENT, INC., BAKERSFIELD,
CA:
4,015,727, PUB. 6-7-2011. INT. CL. 35.
- NEW DAWN TECHNOLOGIES, LOGAN, UT:
3,586,369, AM. INT. CL. 9.
- NEW ENGLAND COOKS, INC., BARRE, VT:
2,911,001, CANC. INT. CL. 41.
- NEW FOCUS INTERNATIONAL CO., LTD., TAIPEI, TAI-
WAN:
2,412,839, CANC. INT. CL. 18.
- NEW HAMPTON CREATIONS, INC., NEW YORK, NY:
4,014,767, PUB. 6-7-2011. INT. CL. 25.
- NEW HARBOUR, INC., FALL RIVER, MA:
2,910,973, CANC. MULTIPLE CLASS, INT. CLS. 18 AND
20.
- NEW HOLLYWOOD ENTERTAINMENT LLC, LILBURN,
GA:
4,015,359, PUB. 6-7-2011. INT. CL. 41.
- NEW HORIZON INDUSTRIES, INC., ATLANTA, GA:
4,015,103, PUB. 6-7-2011. INT. CL. 39.
- NEW IMAGE GLOBAL, INC., CORONA, CA:
4,014,300, PUB. 7-21-2009. INT. CL. 34.
- NEW POTATO TECHNOLOGIES, INC., WILMINGTON, NC:
4,017,154, INT. CL. 9.
- NEW PRODUCT INNOVATIONS, INC., POWELL, OH:
2,910,368, CANC. INT. CL. 42.
- NEW-MODELLE, INC., VAN NUYS, CA:
2,412,524, CANC. MULTIPLE CLASS, INT. CLS. 18 AND
25.
- NEW, KEVIN WAYNE, HERMITAGE, TN:
2,911,612, CANC. INT. CL. 37.
- NEWAYS, INC., SALEM, UT:
2,413,225, CANC. INT. CL. 3.
- NEWKON, LLC, ARCADIA, CA:
4,014,341, PUB. 6-7-2011. INT. CL. 25.
- NEWLINE SOFTWARE, INC., REDMOND, WA:
4,016,302, INT. CL. 9.
- NEWMAN, ARIELLE THOMAS, KANSAS CITY, MO:
2,584,980, REN. 7-19-11. INT. CL. 41.
- NEWPORT CORPORATION, IRVINE, CA:
1,654,202, REN. 7-20-11. INT. CL. 9.
1,654,202, CANC. MULTIPLE CLASS, INT. CLS. 16 AND
42.
- NEWPORT INTERNATIONAL FILM FESTIVAL, NEW-
PORT, RI:
2,412,421, CANC. INT. CL. 41.
- NEWSTAR BUSINESS CREDIT, LLC, DALLAS, TX:
2,910,807, CANC. INT. CL. 41.
- NEWTON-WELLESLEY HOSPITAL, NEWTON, MA:
2,562,037, REN. 7-18-11. INT. CL. 42.
- NEXIANT, LAKE FOREST, CA:
2,911,350, CANC. INT. CL. 35.
2,911,351, CANC. INT. CL. 35.
- NEXSTAR, INC., LITTLE CANADA, MN:
4,015,834, PUB. 6-7-2011. INT. CL. 37.
- NEXT GENERATION LOGISTICS, INC., INVERNESS, IL:
4,014,421, PUB. 6-7-2011. INT. CL. 9.
- NEXT SHIFT ENTERPRISES, LLC, ELLICOTT CITY, MD:
2,910,754, CANC. INT. CL. 36.
- NEXTCHOICE, INC., PORTSMOUTH, NH:
2,910,677, CANC. INT. CL. 9.
- NEXTMARK, INC., HANOVER, NH:
2,468,036, REN. 7-18-11. INT. CL. 35.
- NEXTSTEP RESOURCES, INC., BLOOMINGTON, MN:
2,910,823, CANC. INT. CL. 35.
- NEXUS INDUSTRIES LIMITED, TELFORD, SHROPSHIRE,
UNITED KINGDOM:
4,014,314, PUB. 6-7-2011. MULTIPLE CLASS, INT. CLS. 6,
9, 11 AND 20.
- NFR INVESTMENTS PTY LIMITED, THORNLEIGH, AUS-
TRALIA:
3,902,480, AM. MULTIPLE CLASS, INT. CLS. 9, 25, 28, 29,
30 AND 35.
- NGK SPARK PLUG CO., LTD., NAGOYA CITY, JAPAN:
2,911,650, CANC. INT. CL. 9.
- NHIP SONG MUSIC, INC, GARLAND, TX:
4,015,116, PUB. 6-7-2011. INT. CL. 9.
- NIAGARA PARKS COMMISSION, NIAGARA FALLS, ON-
TARIO, CANADA:
2,909,414, CANC. MULTIPLE CLASS, INT. CLS. 25 AND
41.
- NIBCO INC., ELKHART, IN:
3,432,676, AM. INT. CL. 6.
3,432,734, AM. INT. CL. 6.
- NICARAGUA TOBACCO IMPORTS, INC., MIAMI, FL, DBA
CUBAN CRAFTERS:
4,016,368, INT. CL. 34.
- NICK RICHMOND, ARLINGTON HEIGHTS, IL:
4,014,219, PUB. 6-7-2011. MULTIPLE CLASS, INT. CLS. 35
AND 37.
- NIELSEN, KJELD, RAMSGATE, KENT, ENGLAND:
2,411,884, CANC. INT. CL. 9.
- NIF GROUP, INC., MANHASSET, NY:
4,015,207, PUB. 6-7-2011. INT. CL. 36.
- NIGHT VISION SYSTEMS, INC., ALLENTOWN, PA:
2,412,602, CANC. INT. CL. 9.
- NIGHTBIRD PRODUCTIONS, INC., WEST HOLLYWOOD,
CA:
4,016,349, INT. CL. 21.
- NIHON DEMPA KOGYO CO., LTD., SHIBUYA-KU, TOKYO,
JAPAN:
4,014,312, PUB. 6-7-2011. MULTIPLE CLASS, INT. CLS. 9
AND 10.
- NINGBO TONGYI METALWORK CO., LTD., CHINA:
4,014,572, PUB. 6-7-2011. INT. CL. 6.
- NINTENDO CO., LTD., KYOTO-SHI, KYOTO, JAPAN:
4,014,274, PUB. 6-7-2011. INT. CL. 28.
4,014,275, PUB. 6-7-2011. INT. CL. 26.
4,014,276, PUB. 6-7-2011. INT. CL. 25.
4,014,277, PUB. 6-7-2011. INT. CL. 16.
- NINTENDO OF AMERICA INC., REDMOND, WA:
4,014,269, PUB. 10-12-2010. INT. CL. 28.
4,014,270, PUB. 11-23-2010. INT. CL. 38.
4,016,344, INT. CL. 9.

NIRVANA HEALTH SERVICES, INC., WINTER PARK, FL:
4,015,417, PUB. 6-7-2011. INT. CL. 44.

NISHIMOTO TRADING CO., LTD., SANTA FE SPRINGS,
CA:
2,412,953, CANC. MULTIPLE CLASS, INT. CLS. 29 AND
30.

NISSAN CHEMICAL INDUSTRIES, LTD., CHIYODO-KU,
TOKYO, JAPAN:
4,016,456, INT. CL. 5.

NISSAN JIDOSHA KABUSHIKI KAISHA, YOKOHAMA-SHI,
KANAGAWA, JAPAN, DBA NISSAN MOTOR CO., LTD.:
4,016,242, INT. CL. 12.

NISSHIN SEIFUN GROUP INC., TOKYO, JAPAN:
2,909,498, CANC. MULTIPLE CLASS, INT. CLS. 29, 30, 31
AND 32.

NITTANY CORPORATION, WILMINGTON, DE:
2,456,621. REN. 7-16-11. INT. CL. 29.

NLIGHT PHOTONICS CORPORATION, VANCOUVER, WA:
4,015,448, PUB. 6-7-2011. MULTIPLE CLASS, INT. CLS. 9
AND 10.
4,015,450, PUB. 6-7-2011. MULTIPLE CLASS, INT. CLS. 9
AND 10.

NNOVIA, INC., SAN JOSE, CA:
2,910,389, CANC. INT. CL. 9.

NO FEAR, INC., CARLSBAD, CA:
2,911,010, CANC. INT. CL. 25.

NO TEARS LEARNING, INC., CABIN JOHN, MD, DBA
HANDWRITING WITHOUT TEARS:
4,017,000, INT. CL. 16.
4,017,001, INT. CL. 16.

NOBEL LEARNING COMMUNITIES, INC., WEST CHE-
STER, PA:
4,015,764, PUB. 6-7-2011. INT. CL. 41.

NOBLE GRACE LLC, NEW YORK, NY:
2,911,040, CANC. INT. CL. 42.

NOBLE LION STORES, STOCKTON, CA:
4,016,938, INT. CL. 35.

NOKIA CORPORATION, FINLAND:
3,120,857, COR. INT. CL. 9.

NOLLETTE, SKYLER B., WEST SACRAMENTO, CA, DBA
NOLLETTE FINANCIAL:
4,015,535, PUB. 6-7-2011. MULTIPLE CLASS, INT. CLS. 35
AND 36.

NOMADIX, INC., AGOURA HILLS, CA:
2,474,459. REN. 7-17-11. INT. CL. 38.

NOR-CAL BEVERAGE CO., INC., WEST SACRAMENTO,
CA:
4,016,222, INT. CL. 25.

NORBIS INNOVATIONS COMPANY, LLC, BROOKLINE,
MA:
4,016,370, INT. CL. 10.

NORMA JEAN HUBBARD, HUNTINGTON BEACH, CA:
4,017,398, INT. CL. 25.

NORMAN ASA, 1324 LYSAKER, NORWAY:
2,411,661, CANC. MULTIPLE CLASS, INT. CLS. 9, 16, 35,
36, 37, 41 AND 42.

NORMAN LOVE CONFECTIONS, INC., FORT MYERS, FL:
4,016,249, MULTIPLE CLASS, INT. CLS. 30 AND 35.

NORRHYDRO OY, FI-96300 ROVANIEMI, FINLAND:
4,014,547, PUB. 6-7-2011. MULTIPLE CLASS, INT. CLS. 7,
9 AND 37.

NORTH AMERICAN ENTERTAINMENT GROUP, BRAN-
FORD, CT:
4,015,428, PUB. 6-7-2011. INT. CL. 41.

NORTH AMERICAN GREEN, INC., EVANSVILLE, IN:
2,413,086, CANC. INT. CL. 19.

NORTH AMERICAN VAN LINES, INC., FORT WAYNE, IN:
914,752. REN. 7-15-11. U.S. CL. 105 (INT. CL. 39).
915,264. REN. 7-15-11. U.S. CL. 105 (INT. CL. 39).

NORTH BAY APPAREL, LLC, NEW YORK, NY:
4,016,377, INT. CL. 25.

NORTH BROWARD HOSPITAL DISTRICT, FORT LAU-
DERDALE, FL:
4,015,242, PUB. 6-7-2011. INT. CL. 44.
4,015,245, PUB. 6-7-2011. INT. CL. 36.

NORTH CREEK CHAMBER OF COMMERCE, NORTH
CREEK, NY:
4,015,303, PUB. 6-7-2011. INT. CL. 35.

NORTH STAR VENTURE MANAGEMENT 2000, LLC,
WALTHAM, MA:
4,015,161, PUB. 6-7-2011. INT. CL. 41.

NORTHCENTRAL UNIVERSITY, INC., PRESCOTT VAL-
LEY, AZ:
4,014,226, PUB. 6-7-2011. INT. CL. 41.

NORTHERN & SHELL TITLES LIMITED, LONDON, ENG-
LAND:
3,191,436, CANC. INT. CL. 16.
3,210,462, CANC. MULTIPLE CLASS, INT. CLS. 9 AND
41.

NORTHERN CROSS ENERGY LIMITED, CALGARY, AL-
BERTA, CANADA:
2,506,947. REN. 7-19-11. INT. CL. 37.

NORTHERN TOOL & EQUIPMENT COMPANY, INC.,
BURNSVILLE, MN:
4,016,336, MULTIPLE CLASS, INT. CLS. 7, 8 AND 20.

NORTHERN VIRGINIA TECHNOLOGY COUNCIL, HERN-
DON, VA:
2,469,813. REN. 7-15-11. INT. CL. 16.

NORTHFIELD INVESTMENTS, INC., PINEVILLE, NC:
2,412,433, CANC. MULTIPLE CLASS, INT. CLS. 36 AND
37.

NORTHPOLE LIMITED, KOWLOON, HONG KONG:
2,910,545, CANC. INT. CL. 22.

NORTHSTAR MEMORIAL GROUP LLC, HOUSTON, TX:
4,015,422, PUB. 6-7-2011. MULTIPLE CLASS, INT. CLS. 44
AND 45.

NORWOOD ABBEY LIMITED, CHELSEA HEIGHTS, VIC-
TORIA, AUSTRALIA:
2,910,333, CANC. MULTIPLE CLASS, INT. CLS. 5 AND
10.

NOVA AURORA CORPORATION, ARLINGTON, TX:
4,017,226, INT. CL. 5.

NOVALIS HOLDINGS LIMITED, WAN CHAI, HONG
KONG:
4,016,841, INT. CL. 27.

NOVARTIS AG, BASEL, SWITZERLAND:
2,910,500, CANC. INT. CL. 44.

NOVARTIS AG, 4056 BASEL, SWITZERLAND:
2,910,739, CANC. INT. CL. 5.

NOVARTIS AG, SWITZERLAND:
3,441,077, CANC. INT. CL. 5.

NOVARTIS AG, BASEL, SWITZERLAND:
4,015,693, PUB. 6-7-2011. INT. CL. 5.
4,015,696, PUB. 6-7-2011. INT. CL. 5.

NOVARTIS VACCINES AND DIAGNOSTICS GMBH, 35041
MARBURG, FED REP GERMANY:
4,016,435, INT. CL. 5.

NOVELLIS, LLC, FRANKLIN, TN:
4,015,120, PUB. 6-7-2011. INT. CL. 37.

NOVOMATIC AG, GUMPOLDSKIRCHEN, AUSTRIA:
2,910,515, CANC. MULTIPLE CLASS, INT. CLS. 9 AND
28.

NOVUS NUTRITION BRANDS, LLC, ST. CHARLES, MO:
4,017,016, INT. CL. 5.

NOXELL CORPORATION, HUNT VALLEY, MD:
2,476,549. REN. 7-16-11. INT. CL. 3.
2,510,528. REN. 7-16-11. INT. CL. 3.

NP IP HOLDINGS LLC, LAS VEGAS, NV:
4,016,505, INT. CL. 43.

NRG ENERGY, INC., PRINCETON, NJ:
4,016,975, INT. CL. 37.
4,017,186, INT. CL. 37.

NSTBC, INC., WILMINGTON, DE:
2,910,024, CANC. INT. CL. 35.

NTE ELECTRONICS, INC., BLOOMFIELD, NJ, PHILIPS
ELECTRONICS NORTH AMERICA CORPORATION,
NEW YORK, NY:
2,436,270. REN. 7-19-11. INT. CL. 9.

NTG PLASTIK SANAYI VE TICARET ANONIM SIRKETI,
TURKEY:
4,014,544, PUB. 6-7-2011. MULTIPLE CLASS, INT. CLS. 6,
17 AND 19.

NTR, S.L., SPAIN:
3,312,946, COR. MULTIPLE CLASS, INT. CLS. 9, 38 AND
42.
3,318,689, COR. MULTIPLE CLASS, INT. CLS. 9, 38 AND

42.
3,378,900, COR. MULTIPLE CLASS, INT. CLS. 9, 38 AND 42.
- NU SCENTS TRADING INC, RIDGEFIELD, NJ:
4,016,578, INT. CL. 3.
- NUERA COMMUNICATIONS, INC., SAN DIEGO, CA:
2,419,597, REN. 7-21-11. INT. CL. 9.
- NUHEAT INDUSTRIES LIMITED, DELTA, BRITISH COLUMBIA V3M6V5, CANADA:
2,412,407, CANC. MULTIPLE CLASS, INT. CLS. 35 AND 37.
- NUSBAUM, ARIEY, BROOKLYN, NY AND MOSHE, DOV, STATEN ISLAND, NY:
2,412,417, CANC. INT. CL. 35.
- NUTRAMARKS, INC., PARK CITY, UT:
2,038,469, CANC. INT. CL. 5.
- NUTRITION INDUSTRY ASSOCIATION WEST, GLENDALE, CA:
4,015,329, PUB. 6-7-2011. INT. CL. 35.
- NUVU DIRECT, INC., CARLSBAD, CA:
2,911,537, CANC. INT. CL. 35.
- NVIDIA CORPORATION, SANTA CLARA, CA:
2,461,368, REN. 7-15-11. INT. CL. 9.
- NY'S BEST PIZZA, INC., STATEN ISLAND, NY:
4,017,147, INT. CL. 43.
- NYC PEACH LLC, NEW YORK, NY:
2,910,981, CANC. MULTIPLE CLASS, INT. CLS. 9 AND 21.
- NYCOMED GMBH, 78467 KONSTANZ, FED REP GERMANY:
4,016,771, INT. CL. 5.
- NYGALA CORP., TETERBORO, NJ:
4,015,525, PUB. 6-7-2011. MULTIPLE CLASS, INT. CLS. 16, 26 AND 28.
- NYON CONCEPTS LIMITED, SAN JUAN, PUERTO RICO:
4,015,682, PUB. 6-7-2011. INT. CL. 38.
4,015,740, PUB. 6-7-2011. INT. CL. 38.
- O.W.D. INCORPORATED, TUPPER LAKE, NY:
2,909,540, CANC. INT. CL. 8.
- O'BANION, JAMIE L, DALLAS, TX:
4,016,956, INT. CL. 3.
- O'NEILL BEVERAGE CO., LTD., PARLIER, CA:
4,016,477, INT. CL. 33.
4,016,552, INT. CL. 33.
4,016,553, INT. CL. 33.
- O'SHEA, CLAYTON, LONDON, UNITED KINGDOM:
4,015,944, PUB. 6-7-2011. INT. CL. 28.
- OÜ TERVISLIKU PIIMA BIOTEHNOLOOGIATE; ARENDUSKESKUS, ESTONIA:
4,014,469, PUB. 6-7-2011. MULTIPLE CLASS, INT. CLS. 1, 5, 29, 30, 31 AND 32.
- OAK CLIFF BIBLE FELLOWSHIP, DALLAS, TX:
4,015,882, PUB. 6-7-2011. MULTIPLE CLASS, INT. CLS. 16, 35 AND 41.
- OAKLAND COUNTY, PONTIAC, MI:
3,023,420, CANC. INT. CL. 41.
- OAKLEY, INC., FOOTHILL RANCH, CA:
2,909,580, CANC. INT. CL. 9.
- OAKWOOD ANIMAL HOSPITAL PC, OAKWOOD, GA:
4,015,138, PUB. 6-7-2011. INT. CL. 44.
- OBCHTCHESTVO S OGRANICHENNOY OTVETSTVENNOST'YU "VILAVI", RUSSIAN FED.:
4,014,590, PUB. 6-7-2011. INT. CL. 5.
- OBCHTCHESTVO S OGRANITCHENNOI; OTVETSTVENNOST'YOU "NAMES", RU-129090 MOSKVA, RUSSIAN FED.:
4,014,476, PUB. 6-7-2011. MULTIPLE CLASS, INT. CLS. 3, 20, 35 AND 42.
- OBCHTCHESTVO S OGRANITCHENNOI; OTVETSTVENNOST'YOU "NAMES", RUSSIAN FED.:
4,014,478, PUB. 6-7-2011. MULTIPLE CLASS, INT. CLS. 3, 20, 35 AND 42.
- OBJECTMETHOD SOFTWARE, INC., CHICAGO, IL:
2,911,346, CANC. INT. CL. 9.
- OCEAN GOLD SEAFOODS, INC., WESTPORT, WA:
1,644,518, REN. 7-15-11. INT. CL. 29.
- OCEAN TRAWLERS HOLDING LTD., WAN CHAI, HONG KONG:
4,016,601, INT. CL. 29.
- OCEAN7 WATCH COMPANY, CORAL SPINGS, FL, DBA OCEAN7 WATCH COMPANY:
4,014,879, PUB. 6-7-2011. INT. CL. 14.
- OD DISTRIBUTORS LLC, TOLEDO, OH:
4,014,385, PUB. 6-7-2011. INT. CL. 9.
- ODESS, DANIEL B., CORAL GABLES, FL:
4,015,331, PUB. 6-7-2011. INT. CL. 36.
- ODYSSEY TRANSLATOR, LLC, KAPOLEI, HI:
4,015,971, PUB. 6-7-2011. INT. CL. 9.
- OENOFOROS AB, SWEDEN:
4,014,579, PUB. 6-7-2011. INT. CL. 33.
4,014,608, PUB. 6-7-2011. INT. CL. 33.
- OERTLI INSTRUMENTE AG, SWITZERLAND:
4,014,626, PUB. 6-7-2011. INT. CL. 10.
- OF RAGS CLOTHING LLC, BETHESDA, MD:
4,014,819, PUB. 6-7-2011. INT. CL. 25.
- OFFENBACHER, DOUG, SANTA ROSA, CA:
4,016,526, INT. CL. 33.
- OFS FITEL, LLC, NORCROSS, GA:
2,457,814, REN. 7-16-11. INT. CL. 9.
- OGI, LLC, CHICAGO, IL:
2,469,252, REN. 7-17-11. INT. CL. 9.
- OH IL ENTERPRISE CO., LTD., SEOUL, REPUBLIC OF KOREA:
4,016,482, INT. CL. 33.
4,016,483, INT. CL. 33.
- OHIO CENTRAL SAVINGS, DUBLIN, OH:
2,910,421, CANC. INT. CL. 36.
- OIL-RITE CORPORATION, MANITOWOC, WI:
2,911,697, CANC. MULTIPLE CLASS, INT. CLS. 7 AND 9.
- OLAES ENTERPRISES, INC., POWAY, CA, DBA ODM:
2,482,406, REN. 7-21-11. INT. CL. 25.
- OLD EUROPEAN BREWERY COMPANY, SAN DIEGO, CA:
2,911,641, CANC. INT. CL. 32.
- OLD LONDON FOODS, INC., BRONX, NY, DEVONSHEER MELBA CORPORATION, CARLSTADT, NJ:
920,822, REN. 7-18-11. U.S. CL. 46 (INT. CLS. 1, 5, 29, 30, 31 AND 32).
- OLDEMARK LLC., BURLINGTON, VT:
2,909,543, CANC. INT. CL. 30.
- OLE HENRIKSEN OF DENMARK, INC., LOS ANGELES, CA:
4,017,377, INT. CL. 3.
- OLIVA CIGAR COMPNAY, MIAMI LAKES, FL:
2,582,279, REN. 7-15-11. INT. CL. 34.
- OLIVE U PRODUCTIONS, INC., TARZANA, CA:
2,910,077, CANC. INT. CL. 25.
- OLIVER CONTI, S.L., 17750 CAPMANY, GIRONA, SPAIN:
2,506,388, REN. 7-15-11. INT. CL. 33.
- OLIVER'S ARTISAN BREADS, INC., LOS ANGELES, CA:
2,910,358, CANC. INT. CL. 30.
- OLIVET INTERNATIONAL, INC., MIRA LOMA, CA:
4,015,580, PUB. 6-7-2011. INT. CL. 25.
4,015,804, PUB. 6-7-2011. INT. CL. 18.
- OLIVIA MILLER, INC, NEW YORK, NY:
4,016,972, INT. CL. 25.
4,017,149, INT. CL. 25.
- OLORTEGUI, HENRY, HARBOR CITY, CA AND AGUIRRE, ERIC, LOS ANGELES, CA:
2,911,053, CANC. INT. CL. 41.
- OLSBERG, COLLEEN A, HOFFMAN ESTATES, IL, DBA THE CHILDREN'S TOMORROW FOUNDATION:
4,016,595, INT. CL. 44.
- OLSON, GARY E., AURORA, CO:
2,910,234, CANC. INT. CL. 16.
- OLYMPIC OIL, LTD., CICERO, IL:
4,015,752, PUB. 6-7-2011. INT. CL. 4.
- OMEGA PROTEIN, INC., HOUSTON, TX:
4,014,983, PUB. 6-7-2011. INT. CL. 31.
- OMNIGLOW, LLC, WEST SPRINGFIELD, MA:
4,017,166, INT. CL. 10.
- OMNIOSS INC, CORNELIUS, NC:
2,910,718, CANC. INT. CL. 9.

OMNITRITION INTERNATIONAL, INC., CARROLLTON, TX:
2,412,406, CANC. INT. CL. 5.

OMS INVESTMENTS, INC., LOS ANGELES, CA:
4,016,381, INT. CL. 21.
4,016,383, INT. CL. 1.
4,017,298, INT. CL. 5.

ON OPTIMUM NUTRITION LIMITED, KILKENNY CITY, IRELAND:
2,910,178, CANC. INT. CL. 5.
4,016,543, INT. CL. 5.
4,016,544, INT. CL. 18.

ONE CONTINENT GROUP, LLC, LAS VEGAS, NV:
4,017,109, INT. CL. 43.
4,017,110, INT. CL. 41.

ONE GLOBAL FINANCE, INC., BOUNTIFUL, UT:
2,911,721, CANC. INT. CL. 36.

ONECROWN, INC., FISHERS, IN:
2,469,228, REN. 7-15-11, INT. CL. 42.

ONECROWN, INC., ANDERSON, IN:
2,522,394, REN. 7-16-11, INT. CL. 16.

ONEIDA L. RAFI-MUHAMMAD, STONEVILLE, NC:
4,014,229, PUB. 6-7-2011, INT. CL. 28.

ONTARIO LOTTERY AND GAMING CORPORATION, TORONTO, ONTARIO, CANADA:
4,016,144, MULTIPLE CLASS, INT. CLS. 18 AND 25.

OPCOM INC., TAIPEI HSIEN, TAIWAN:
4,016,539, INT. CL. 11.

OPEN COMPLIANCE & ETHICS GROUP, PHOENIX, AZ:
2,909,618, CANC. MULTIPLE CLASS, INT. CLS. 41 AND 42.

OPEN HEALTH SERVICES CANADA LTD., CALGARY, ALBERTA, CANADA:
4,014,747, PUB. 6-7-2011, INT. CL. 39.

OPEN MEDIA FOUNDATION DBA DEPRODUCTION, DENVER, CO:
4,016,404, INT. CL. 41.

OPSEC SECURITY GROUP, INC., DENVER, CO:
4,016,145, MULTIPLE CLASS, INT. CLS. 35 AND 42.

OPTOS PUBLIC LIMITED COMPANY, DUNFERMLINE, FIFE, UNITED KINGDOM:
2,469,922, REN. 7-15-11, MULTIPLE CLASS, INT. CLS. 10 AND 42.

ORACLE AMERICA, INC., REDWOOD SHORES, CA:
2,911,317, CANC. INT. CL. 42.
4,014,338, PUB. 6-7-2011, INT. CL. 9.

ORBACH, WENDY, TORONTO, ONTARIO, CANADA:
4,016,713, INT. CL. 21.

ORBIS HOLDINGS LIMITED, HAMILTON, BERMUDA:
4,014,258, PUB. 6-7-2011, INT. CL. 36.
4,014,259, PUB. 6-7-2011, INT. CL. 36.

ORCHARD MANUFACTURING CO. PTY. LTD., BAYS-WATER VIC 3153, AUSTRALIA:
2,457,624, REN. 7-15-11, INT. CL. 5.

ORECK HOLDINGS, LLC, NASHVILLE, TN:
2,471,040, REN. 7-19-11, INT. CL. 7.

OREGON HEALTH & SCIENCE UNIVERSITY, PORTLAND, OR:
4,015,046, PUB. 6-7-2011, INT. CL. 41.

ORGANICALLY GROWN GROUP, LLC, SANTA BARBARA, CA:
4,016,451, INT. CL. 27.
4,016,458, INT. CL. 27.

OROCO LIMITED, CAUSEWAY BAY, HONG KONG:
2,491,724, REN. 7-16-11, INT. CL. 18.

OROLATINA LLC, CLIFTON, NJ:
4,016,789, INT. CL. 35.

ORTHOSENSOR INC., SUNRISE, FL:
4,016,342, INT. CL. 44.

OSEDO, MARK, LEE, HONOLULU, HI:
2,910,640, CANC. INT. CL. 25.

OSG TAP & DIE, INC., GLENDALE HEIGHTS, IL:
1,664,721, REN. 7-18-11, INT. CL. 7.

OSHKOSH B'GOSH, INC., ATLANTA, GA:
558,416, REN. 7-20-11, U.S. CL. 39 (INT. CLS. 10, 25 AND 26).

OSHRY, SCOTT, LOS ANGELES, CA:
4,016,159, INT. CL. 3.

OSRAM GESELLSCHAFT MIT BESCHRÄNKTER HAF-TUNG, FED REP GERMANY:
4,014,447, PUB. 6-7-2011, MULTIPLE CLASS, INT. CLS. 9 AND 11.
4,014,611, PUB. 6-7-2011, INT. CL. 11.

OSYPKA MEDICAL GMBH, BERLIN, FED REP GERMANY:
4,016,229, INT. CL. 10.
4,016,230, INT. CL. 10.

OTIS SPUNKMEYER, LLC, SAN LEANDRO, CA, PENNANT FOODS COMPANY, ITASCA, IL:
2,488,507, REN. 7-19-11, INT. CL. 30.

OUTER BANKS FISHING CHARTERS, KILL DEVIL HILLS, NC:
4,017,420, INT. CL. 39.

OUTLOOK SKATEBOARDS, LLC, SMITHFIELD, VA:
2,909,797, CANC. INT. CL. 28.

OUTOTEC (FILTERS) OY, 53900 LAPPEENRANTA, FIN-LAND:
1,155,313, REN. 7-19-11, INT. CL. 7.

OUTSOURCING SOLUTIONS, INC., CHESTERFIELD, MO:
2,466,315, REN. 7-15-11, MULTIPLE CLASS, INT. CLS. 35 AND 36.

OVAL CORPORATION, SHINJUKU-KU TOKYO, JAPAN:
2,050,084, REN. 7-20-11, INT. CL. 9.

OVERDEVEST NURSERIES, L.P., BRIDGETON, NJ:
4,017,134, INT. CL. 21.

OVERHEAD DOOR CORPORATION, LEWISVILLE, TX:
2,411,986, CANC. INT. CL. 6.

OVERSEAS MEDICAL FUND, INC., VIRGINIA BEACH, VA:
4,015,507, PUB. 6-7-2011, INT. CL. 44.

OWENS CORNING INTELLECTUAL CAPITAL, LLC, TO-LEDO, OH, OWENS-CORNING FIBERGLAS CORPORA-TION, TOLEDO, OH:
1,171,267, REN. 7-15-11, INT. CL. 19.

OWENS, DANIEL, FREDERICK, NASHVILLE, TN:
4,017,337, INT. CL. 35.

OWN YOUR MONEY LLC, SOUTH BOSTON, MA:
4,016,937, MULTIPLE CLASS, INT. CLS. 9, 35, 36 AND 41.

OXFORD BIOMEDICA PLC, OXFORD, UNITED KING-
DOM:
4,014,320, PUB. 1-18-2011, MULTIPLE CLASS, INT. CLS. 1, 5, 10 AND 42.

OZVISION GLOBAL INC., LYNN, MA:
2,909,948, CANC. INT. CL. 9.

P. ANTINORI S.P.A., I-50123 FIRENZE, ITALY:
4,014,588, PUB. 6-7-2011, INT. CL. 42.

P. H. GLATFELTER COMPANY, YORK, PA:
2,910,246, CANC. INT. CL. 16.

P.F. CHANG'S CHINA BISTRO, INC., SCOTTSDALE, AZ:
4,017,170, INT. CL. 43.

P.S. PRODUCTS, INC., LITTLE ROCK, AR:
4,014,352, PUB. 6-7-2011, INT. CL. 13.

PACIFIC BIOSCIENCES OF CALIFORNIA, INC., MENLO PARK, CA:
4,016,217, INT. CL. 9.

PACIFIC COAST FEATHER COMPANY, SEATTLE, WA:
2,910,162, CANC. MULTIPLE CLASS, INT. CLS. 20 AND 24.
2,911,538, CANC. MULTIPLE CLASS, INT. CLS. 20 AND 24.

PACIFIC COAST FITNESS LLC, LOS ANGELES, CA, DBA GRATITUDE ORGANICS:
4,016,396, INT. CL. 25.

PACIFIC CORNETTA, INC., WILSONVILLE, OR:
2,412,580, CANC. INT. CL. 21.

PACIFIC CYCLE, LLC, MADISON, WI:
2,911,127, CANC. INT. CL. 28.

PACIFIC SALES UK LIMITED, WHITEGATE, CHESHIRE, UNITED KINGDOM:
3,880,759, COR. INT. CL. 3.

PACIFIC SCIENTIFIC COMPANY, DUARTE, CA:
1,154,580, REN. 7-15-11, MULTIPLE CLASS, INT. CLS. 9 AND 12.

PACIFIC WORLD CORPORATION, LAKE FOREST, CA:
4,016,142, PUB. 6-7-2011, INT. CL. 3.

PACKAGING SERVICE CO., INC., PEARLAND, TX:
2,412,397, CANC. INT. CL. 11.

- PACTIV CORPORATION, LAKE FOREST, IL, PACTIV CORPORATION, LAKE FOREST, IL:
2,469,016. REN. 7-20-11. INT. CL. 21.
- PACTOOL INTERNATIONAL LTD., KINGSTON, WA:
2,412,963, CANC. INT. CL. 7.
- PAIZO PUBLISHING, LLC, REDMOND, WA:
4,016,098, PUB. 6-7-2011. INT. CL. 28.
- PALMER FIXTURE COMPANY, GREEN BAY, WI:
4,016,630, INT. CL. 11.
- PALMET, KEVIN, NEW YORK, NY:
2,910,287, CANC. INT. CL. 41.
- PALMROTH INTERNATIONAL B.V., WAALWIJK, NETHERLANDS:
1,631,620. REN. 7-19-11. MULTIPLE CLASS, INT. CLS. 18 AND 25.
- PAMELA PIERNE, SHELTON, CT, DBA HONEY BUNNY BABY:
4,014,722, PUB. 6-7-2011. INT. CL. 25.
- PAN COMMUNICATIONS, INC., MINATO-KU, TOKYO 107, JAPAN:
2,911,488, CANC. INT. CL. 9.
- PAN-PRO L.L.C., TINLEY PARK, IL:
2,574,095. REN. 7-16-11. MULTIPLE CLASS, INT. CLS. 9 AND 42.
- PANARO CONSTRUCTION, INC., ELKTON, MD AND PANARO CONSTRUCTION, INC., ELKTON, MD:
4,014,289, PUB. 6-7-2011. INT. CL. 37.
- PANAVISION INC., WOODLAND HILLS, CA, PANAVISION, INCORPORATED, TARZANA, CA:
1,160,790. REN. 7-15-11. INT. CL. 9.
- PANAX ETEC CO., LTD., BUSAN, REPUBLIC OF KOREA:
4,017,270, INT. CL. 1.
- PANIZZI, RON, BOCA RATON, FL:
2,481,642. REN. 7-18-11. INT. CL. 36.
- PANLINE U.S.A., INC., WASHINGTON, D.C., DC:
2,150,965, CANC. INT. CL. 16.
- PANTA SYSTEMS, INC., CUPERTINO, CA:
3,130,908, CANC. INT. CL. 9.
3,160,179, CANC. INT. CL. 9.
- PANTECH CO., LTD., MAPO-GU, SEOUL, REPUBLIC OF KOREA:
4,016,980, INT. CL. 9.
- PANTELEAKIS BROS. INTERNATIONAL LLC, FAIR LAWN, NJ:
2,909,998, CANC. INT. CL. 29.
- PAPER MART, INC., EAST HANOVER, NJ:
4,017,210, MULTIPLE CLASS, INT. CLS. 35 AND 40.
- PAPPAS, PETER GREGG, HIALEAH, FL:
4,015,347, PUB. 6-7-2011. INT. CL. 21.
- PAPPAS, RANDALL J, NEW BRAUNFELS, TX:
4,015,528, PUB. 6-7-2011. INT. CL. 9.
- PARA, GERARD A., LONG GROVE, IL:
2,460,420. REN. 7-20-11. INT. CL. 35.
- PARABELLUM COLLECTION INC., LOS ANGELES, CA:
4,016,205, INT. CL. 25.
- PARAGAMIAN, JON, COEUR D'ALENE, ID:
4,015,893, PUB. 6-7-2011. INT. CL. 20.
- PARALLOCITY, INC, SUNNYVALE, CA:
4,015,052, PUB. 6-7-2011. INT. CL. 9.
- PARDALES, PAUL C, WATERFORD, MI:
2,911,285, CANC. INT. CL. 40.
- PARFUMS CHRISTIAN DIOR, 75008 PARIS, FRANCE:
2,910,414, CANC. INT. CL. 3.
2,910,547, CANC. INT. CL. 3.
2,911,194, CANC. INT. CL. 3.
- PARGH, ANDREW L., BOCA RATON, FL:
2,909,637, CANC. INT. CL. 35.
- PARIS PRESENTS INCORPORATED, GURNEE, IL:
4,017,264, INT. CL. 21.
- PARK AND COMPANY MARKETING COMMUNICATIONS, INC., PHOENIX, AZ:
2,911,098, CANC. INT. CL. 35.
- PARK CITY GROUP, INC., PARK CITY, UT:
4,015,316, PUB. 6-7-2011. INT. CL. 42.
- PARK VERLAG GMBH, FED REP GERMANY:
4,014,634, PUB. 6-7-2011. MULTIPLE CLASS, INT. CLS. 25, 28 AND 41.
- PARK-RITE, INC., DETROIT, MI:
2,909,894, CANC. INT. CL. 39.
2,909,895, CANC. INT. CL. 39.
- PARK, PIO Y., SEATTLE, WA, DBA PYP ENTERPRISES LLC & PYPE INC:
2,584,803. REN. 7-15-11. INT. CL. 35.
- PARKER & PARKER, INC., MILFORD, PA:
2,910,400, CANC. INT. CL. 35.
- PARKER, SASHA, FORT LAUDERDALE, FL:
2,910,553, CANC. INT. CL. 41.
- PARLEY ENTERTAINMENT, INC., RALEIGH, NC:
4,016,486, INT. CL. 28.
- PARTNERSHIP FOR CLEAR HEALTH COMMUNICATION, INC., WASHINGTON, DC:
2,910,532, CANC. MULTIPLE CLASS, INT. CLS. 16 AND 35.
- PASADENA CITY COLLEGE, PASADENA, CA:
4,014,731, PUB. 6-7-2011. MULTIPLE CLASS, INT. CLS. 6, 14, 16, 18, 21, 24, 25, 28, 38, 39 AND 41.
- PAST BASKET, INC., GENEVA, IL:
2,576,273. REN. 7-18-11. MULTIPLE CLASS, INT. CLS. 35 AND 42.
- PAT O'BRIEN'S BAR, INC., NEW ORLEANS, LA:
1,683,476. REN. 7-20-11. INT. CL. 33.
- PATCH MEDIA CORPORATION, NEW YORK, NY:
4,014,291, PUB. 6-7-2011. MULTIPLE CLASS, INT. CLS. 35, 38 AND 41.
- PATHOGENETIX, INC., WOBURN, MA:
2,909,577, CANC. INT. CL. 9.
- PATHWAY HOLDINGS, LLC, MANGO, FL:
2,910,993, CANC. INT. CL. 1.
- PATHWORK FOUNDATION, THE, CHARLOTTESVILLE, VA:
1,173,666. REN. 7-20-11. INT. CL. 41.
- PATISEN, DAKAR, SENEGAL:
4,015,606, PUB. 6-7-2011. INT. CL. 29.
4,015,611, PUB. 6-7-2011. INT. CL. 30.
- PATRICIA FISHER, AURORA, CO:
4,015,950, PUB. 6-7-2011. INT. CL. 16.
- PATRICIA JIMENEZ, SAN ANTONIO, TX, DBA THE RAUL JIMENEZ ANNUAL THANKSGIVING DINNER FUND, INC.:
- 4,014,968, PUB. 6-7-2011. INT. CL. 36.
- PATRICK HOLDINGS APS, 3490 FREDENSBORG, DENMARK:
3,773,949, COR. MULTIPLE CLASS, INT. CLS. 18, 25 AND 28.
- PATRICK JOSEPH QUIRKE, BURKE, VA, DBA INKSENSE:
4,015,300, PUB. 6-7-2011. INT. CL. 2.
- PATRICK VOGEL DESIGNS, INC., SIGNAL HILL, CA:
4,016,810, INT. CL. 21.
- PATTERN ENERGY GROUP LP, SAN FRANCISCO, CA:
4,016,341, INT. CL. 39.
- PATTERSON, DEBBIE, SIDNEY, ME:
4,015,113, PUB. 6-7-2011. INT. CL. 41.
- PAUL DAVIS RESTORATION, INC., JACKSONVILLE, FL:
2,530,592. REN. 7-15-11. INT. CL. 35.
- PAUL FANNY, HOOKSETT, NH:
4,014,872, PUB. 6-7-2011. INT. CL. 41.
4,014,873, PUB. 6-7-2011. INT. CL. 41.
4,014,874, PUB. 6-7-2011. INT. CL. 41.
- PAUL J. AMO, SUMMERFIELD, FL, DBA KUFF ENTERPRISES LLC:
4,016,576, INT. CL. 6.
- PAUL JOSEPH GORODNICK, GAINESVILLE, VA:
4,016,555, INT. CL. 28.
- PAUL SPEAKMAN, LOS ANGELES, CA:
4,017,418, INT. CL. 15.
- PAXTON, GRAHAM, EVANSVILLE, IN:
4,016,167, INT. CL. 35.
4,016,168, INT. CL. 35.
- PAYMENTONE CORPORATION, SAN JOSE, CA:
2,469,591. REN. 7-19-11. INT. CL. 36.
- PAYSQUARE B.V., NETHERLANDS:
3,032,478, CANC. MULTIPLE CLASS, INT. CLS. 9 AND 36.
3,051,016, CANC. INT. CL. 36.

PAYSTATION, INC., MISSISSAUGA, ONTARIO, CANADA:
2,909,467, CANC. INT. CL. 35.

PAZKAR LTD., AFULA, ISRAEL:
4,014,676, PUB. 6-7-2011. MULTIPLE CLASS, INT. CLS. 2
AND 17.

PC ON CALL, INC., CINCINNATI, OH:
2,909,485, CANC. MULTIPLE CLASS, INT. CLS. 37 AND
42.

PCM ANIMATION STUDIOS, INC., SILVER SPRING, MD:
4,014,895, PUB. 6-7-2011. MULTIPLE CLASS, INT. CLS. 35
AND 41.

PDC BRUSH N.V., IZEGEM, BELGIUM:
2,909,760, CANC. INT. CL. 21.
2,909,761, CANC. INT. CL. 21.

PDM URETHANE, LLC, SANTA ANA, CA:
2,911,514, CANC. INT. CL. 1.

PDS PATHOLOGY DATA SYSTEMS AG, BIRSFELDEN,
SWITZERLAND:
1,646,742, REN. 7-16-11. INT. CL. 9.

PEABODY MANAGEMENT, INC., MEMPHIS, TN:
2,467,741, REN. 7-16-11. INT. CL. 24.
2,469,553, REN. 7-19-11. INT. CL. 25.

PEAK ACQUISITIONS, LLC, LISLE, IL:
2,909,430, CANC. INT. CL. 30.

PEAK PERFORMANCE REHABILITATION LLC, FORT
LAUDERDALE, FL:
4,015,369, PUB. 6-7-2011. INT. CL. 44.

PEAVEY ELECTRONICS CORPORATION, MERIDIAN, MS:
2,911,105, CANC. INT. CL. 9.

PEGASUS IMAGING CORPORATION, TAMPA, FL:
2,571,768, REN. 7-16-11. INT. CL. 9.

PEGASUS LEARNING SYSTEMS CORPORATION, EVER-
GREEN, CO, DBA INSIDER TRAINING:
2,910,569, CANC. INT. CL. 41.

PEGASUS SOLUTIONS, INC., DALLAS, TX, PEGASUS
SOLUTIONS, INC., DALLAS, TX:
2,471,934, REN. 7-19-11. MULTIPLE CLASS, INT. CLS. 39
AND 42.

PEGASUS SOLUTIONS, INC., DALLAS, TX:
2,910,910, CANC. INT. CL. 38.

PEI LICENSING, INC., MIAMI, FL:
2,411,638, CANC. INT. CL. 25.
2,412,717, CANC. INT. CL. 3.

PEI WEI ASIAN DINER, INC., SCOTTSDALE, AZ:
4,015,271, PUB. 6-7-2011. INT. CL. 43.

PELAR, INC., HAMDEN, CT:
1,650,826, REN. 7-18-11. INT. CL. 25.

PELERIN INTERNATIONAL LLC., LOMBARD, IL, DBA
DAGNY & LANE:
4,015,644, PUB. 6-7-2011. MULTIPLE CLASS, INT. CLS. 3
AND 4.

PELICAN INTERNATIONAL INC., LAVAL, CANADA, ES-
KAY PLASTICS LTD., CHOMEDEY, LAVAL, PROVINCE
OF QUEBEC, CANADA:
1,193,936, REN. 7-18-11. INT. CL. 12.

PELLERIN MILNOR CORPORATION, KENNER, LA:
4,015,212, PUB. 6-7-2011. INT. CL. 7.

PELLOW INVESTMENTS, LLC, SHELBY TOWNSHIP, MI:
4,014,390, PUB. 6-7-2011. INT. CL. 35.

PENALVER, JOSE ELIAS CARRASCO, 28034-MADRID,
SPAIN:
2,409,120, CANC. MULTIPLE CLASS, INT. CLS. 20 AND
42.

PENDERGRAFT, GENE, MARICOPA, AZ AND PENDER-
GRAFT, LEIGH, MARICOPA, AZ AND PENDERGRAFT,
MARC, MARICOPA, AZ:
4,016,957, INT. CL. 40.

PENGUIN POINT FRANCHISE SYSTEMS, INC., WARSAW,
IN:
923,337, REN. 7-18-11. U.S. CL. 100 (INT. CL. 42).

PENNSYLVANIA CHAMBER OF BUSINESS AND INDUS-
TRY, HARRISBURG, PA:
4,014,760, PUB. 6-7-2011. INT. CL. 35.

PENNSYLVANIA HIGHER EDUCATION ASSISTANCE
AGENCY, HARRISBURG, PA:
2,909,462, CANC. MULTIPLE CLASS, INT. CLS. 36 AND
41.

PENNWELL CORPORATION, TULSA, OK:
4,017,419, INT. CL. 41.

PENNY ARCADE, SEATTLE, WA:
4,015,923, PUB. 6-7-2011. INT. CL. 9.

PENTAIR WATER POOL AND SPA, INC., SANFORD, NC:
2,911,232, CANC. INT. CL. 11.

PENTUCKET BANK, HAVERHILL, MA:
4,014,890, PUB. 6-7-2011. INT. CL. 36.

PEOPLEMETRICS, INC., PHILADELPHIA, PA:
2,588,800, REN. 7-19-11. INT. CL. 35.

PEOPLES BANK SB, MUNSTER, IN:
2,911,289, CANC. INT. CL. 36.

PEPCO HOLDINGS, INC., WASHINGTON, DC:
2,549,370, REN. 7-15-11. INT. CL. 42.

PERFECT PROMOTIONAL PRODUCTS, LLC, OXNARD,
CA:
2,110,882, CANC. INT. CL. 21.

PERFETTI VAN MELLE SPA, MILAN, ITALY:
2,910,250, CANC. INT. CL. 30.

PERFORMANCE FOOD GROUP, INC., RICHMOND, VA:
4,016,080, PUB. 6-7-2011. INT. CL. 29.

PERFORMANCE, INC., CHAPEL HILL, NC:
2,421,087, REN. 7-15-11. INT. CL. 35.
2,421,089, REN. 7-15-11. INT. CL. 35.

PERFUMANIA, INC., SUNRISE, FL:
4,015,033, PUB. 3-1-2011. MULTIPLE CLASS, INT. CLS. 3
AND 4.

PERIPHERAL DYNAMICS, INC., PLYMOUTH MEETING,
PA:
913,257, REN. 7-18-11. U.S. CL. 26 (INT. CL. 9).

PERKINS & WILL, INC., ATLANTA, GA:
2,909,607, CANC. INT. CL. 35.

PERKIOMEN VALLEY CHAMBER OF COMMERCE, COL-
LEGEVILLE, PA:
2,590,891, REN. 7-15-11. INT. CL. 35.

PERMA-CHINK SYSTEMS, INC., REDMOND, WA:
4,014,775, PUB. 6-7-2011. INT. CL. 17.

PERMEATOR DISTRIBUTORS LLC, HUDSONVILLE, MI:
4,014,868, PUB. 6-7-2011. MULTIPLE CLASS, INT. CLS. 1
AND 3.

PERNOD RICARD, 75016 PARIS, FRANCE, ETABLISSE-
MENTS PERNOD, MAISONS PERNOD FILS, HEMARD
ET PERNOD PERE ET FILS REUNIES. (SOCIETE ANON-
YME), PARIS, FRANCE:
544,243, REN. 7-19-11. U.S. CL. 49 (INT. CL. 33).

PERRY, LENORE E., LEO, IN:
2,473,908, REN. 7-15-11. INT. CL. 35.

PERSINGER, JOHN, SAN RAMON, CA, DBA ABC'S OF
SELF DEFENSE:
2,910,432, CANC. INT. CL. 16.

PERSISTENT CACHE PTY LTD AS TRUSTEE FOR PERSIS-
TENT CACHE UNIT TRUST, NUNAWADING, AUSTRA-
LIA:
4,014,550, PUB. 6-7-2011. INT. CL. 9.

PERUVIAN IMPORT COMPANY, INC., PASSAIC, NJ:
4,014,215, PUB. 6-7-2011. MULTIPLE CLASS, INT. CLS. 29
AND 30.

PET FILES, LAGUNA HILLS, CA:
2,909,403, CANC. INT. CL. 41.

PET HEAD, INC., MALIBU, CA:
4,016,722, INT. CL. 3.

PETER ARNOLD, INC., NEW YORK, NY:
2,911,190, CANC. INT. CL. 42.

PETER BORTZ, PRESIDENT, WASHINGTON, DC, DBA
GEORGETOWN FRAME SHOPPE:
4,015,111, PUB. 6-7-2011. MULTIPLE CLASS, INT. CLS.
35, 36, 37 AND 40.

PETER FISH & CO. PTY. LTD, GORDON, NSW, AUSTRA-
LIA:
4,016,676, INT. CL. 28.

PETEY'S TACKLE, LLC, HAGUE, VA:
4,015,824, PUB. 6-7-2011. INT. CL. 35.

PETRECO INTERNATIONAL, INC., HOUSTON, TX:
4,014,862, PUB. 6-7-2011. INT. CL. 11.

PETROCARD INC., KENT, WA:
4,015,104, PUB. 6-7-2011. INT. CL. 4.

PFIP, LLC, NEWINGTON, NH:
4,015,427, PUB. 6-7-2011. INT. CL. 41.

- PFIZER INC, NEW YORK, NY:
2,909,974, CANC. INT. CL. 16.
- PFIZER INC., NEW YORK, NY:
2,470,816, REN. 7-19-11. INT. CL. 5.
2,910,533, CANC. MULTIPLE CLASS, INT. CLS. 16 AND 35.
2,910,906, CANC. INT. CL. 44.
2,911,604, CANC. MULTIPLE CLASS, INT. CLS. 16 AND 44.
- PFM MEDICAL, INC., CARLSBAD, CA:
4,015,067, PUB. 3-1-2011. INT. CL. 10.
- PGA TOUR, INC., PONTE VEDRA BEACH, FL:
2,482,405, REN. 7-20-11. INT. CL. 41.
2,482,405, AM. INT. CL. 41.
- PGMP SOLUTIONS, INC, CHANDLER, AZ:
4,017,114, INT. CL. 9.
- PHARMACA INTEGRATIVE PHARMACY, INC., BOULDER, CO:
4,015,093, PUB. 6-7-2011. MULTIPLE CLASS, INT. CLS. 41 AND 44.
- PHI DELTA PHI INTERNATIONAL LEGAL FRATERNITY, WASHINGTON, DC:
1,688,259, REN. 7-19-11. U.S. CL. 200.
- PHI KAPPA TAU FRATERNITY, THE, OXFORD, OH:
287,744, REN. 7-18-11. U.S. CL. 28 (INT. CL. 14).
- PHIFER INCORPORATED, TUSCALOOSA, AL:
1,159,693, REN. 7-16-11. INT. CL. 6.
- PHILIPS AUSTRIA GMBH, VIENNA, AUSTRIA:
1,630,658, REN. 7-18-11. INT. CL. 9.
- PHILOSOPHY, INC., PHOENIX, AZ:
4,014,978, PUB. 6-7-2011. INT. CL. 25.
- PHILIP 'N' NIK CORPORATION, LOS ANGELES, CA:
4,015,895, PUB. 6-7-2011. INT. CL. 30.
- PHOSEON TECHNOLOGY, INC., HILLSBORO, OR:
4,016,653, INT. CL. 11.
- PHOTOFLEX, INC., WATSONVILLE, CA:
4,017,375, INT. CL. 6.
- PHYHEALTH CORPORATION, MIAMI, FL:
4,014,693, PUB. 6-7-2011. INT. CL. 44.
- PHYSICIANS CARE ALLIANCE, LLC, SCOTTSDALE, AZ:
4,014,975, PUB. 6-7-2011. INT. CL. 3.
- PHYTSOURCE, INC., LEXINGTON, KY:
4,015,828, PUB. 6-7-2011. MULTIPLE CLASS, INT. CLS. 1 AND 5.
- PIAGGIO & C.S.P.A., PONTEDERA, ITALY:
2,965,400, CANC. INT. CL. 3.
- PICCOLO CHEF, LLC, HOLLYWOOD, CA:
4,015,536, PUB. 6-7-2011. INT. CL. 41.
- PICKER INTERNATIONAL, INC., CLEVELAND, OH:
1,801,986, CANC. INT. CL. 10.
- PIERCE COLEMAN INC., FOX LAKE, IL:
4,014,988, PUB. 6-7-2011. INT. CL. 30.
- PIERRE FABRE DERMO-COSMETIQUE, BOULOGNE, FRANCE:
4,015,030, PUB. 6-7-2011. MULTIPLE CLASS, INT. CLS. 3 AND 5.
- PIKE NURSERIES ACQUISITION, LLC, DULUTH, GA:
4,016,489, INT. CL. 35.
4,016,491, INT. CL. 35.
4,016,493, MULTIPLE CLASS, INT. CLS. 25, 35 AND 44.
4,016,494, MULTIPLE CLASS, INT. CLS. 35 AND 44.
4,016,495, MULTIPLE CLASS, INT. CLS. 25, 35 AND 44.
4,016,496, MULTIPLE CLASS, INT. CLS. 35 AND 44.
- PILGRIM INTERNATIONAL, INC., MIDDLEBURY, IN:
2,911,227, CANC. INT. CL. 12.
- PINDELL ENGINEERING LLC, PORT TOWNSEND, WA:
4,016,865, INT. CL. 1.
- PINEWAY PTY LTD T/ ANDREW HARRIS VINEYARDS, MUDGEE 2850, NEW SOUTH WALES, AUSTRALIA:
2,910,767, CANC. INT. CL. 33.
- PIRATE SA, FRANCE:
3,752,376, CANC. INT. CL. 25.
- PISCO PORTON, LLC, HOUSTON, TX:
4,016,736, INT. CL. 33.
- PITNEY BOWES INC., STAMFORD, CT:
4,014,823, PUB. 6-7-2011. INT. CL. 9.
- PITTSBURGH PENGUINS LP, PITTSBURGH, PA:
4,015,704, PUB. 6-7-2011. INT. CL. 41.
- PIVI & CO, FRANCE:
4,014,643, PUB. 6-7-2011. INT. CL. 9.
- PIVOT MEDICAL, INC., SUNNYVALE, CA:
4,016,343, INT. CL. 10.
- PIXELVISION, INC., LEXINGTON, KY:
2,412,455, CANC. INT. CL. 9.
- PJR HOLDINGS LIMITED, MIRAMAR, WELLINGTON, NEW ZEALAND:
4,014,391, PUB. 6-7-2011. MULTIPLE CLASS, INT. CLS. 9, 14, 20 AND 42.
- PK'S CHOCOLATES INC., NEWHALL, CA:
4,017,203, INT. CL. 30.
- PLAGE S.A., FRANCE:
4,014,481, PUB. 6-7-2011. INT. CL. 16.
- PLAINSCAPITAL CORPORATION, DALLAS, TX:
4,014,205, PUB. 6-7-2011. INT. CL. 36.
- PLAN B DESIGN, LLC, REDMOND, WA:
4,015,903, PUB. 6-7-2011. INT. CL. 28.
- PLAN-MÉCANO 3D INC., SAINT-MALACHIE, PROVINCE DE QUÉBEC, CANADA:
2,910,425, CANC. INT. CL. 19.
- PLANALYTICS, INC., WAYNE, PA, PLANALYTICS, INC., WAYNE, PA:
2,572,029, REN. 7-18-11. INT. CL. 9.
- PLANET ZOLON RESTAURANT CONCEPTS, INC., FORT WORTH, TX:
2,911,527, CANC. INT. CL. 43.
- PLANSARK LLC, LAKEWOOD, OH:
4,015,793, PUB. 6-7-2011. INT. CL. 9.
- PLANT REVOLUTION, INC., FULLERTON, CA:
2,412,118, CANC. INT. CL. 1.
- PLASTEEL, INC., CARLSBAD, CA:
2,487,586, REN. 7-18-11. INT. CL. 6.
- PLASTIC PROCESS EQUIPMENT, INC., MACEDONIA, OH:
4,015,389, PUB. 6-7-2011. INT. CL. 11.
- PLASTIFLEX GROUP, NAAMLOZE VENNOOTSCHAP, BELGIUM:
4,014,498, PUB. 6-7-2011. MULTIPLE CLASS, INT. CLS. 9, 10 AND 17.
- PLATINUM SOLUTIONS GROUP, LLC, ATLANTA, GA:
2,910,002, CANC. INT. CL. 36.
- PLAYBOY ENTERPRISES INTERNATIONAL, INC., CHICAGO, IL:
2,469,441, REN. 7-19-11. INT. CL. 21.
- PLAYBOY ENTERPRISES, INC., CHICAGO, IL:
721,987, REN. 7-15-11. U.S. CL. 38 (INT. CL. 16).
- PLAYGROUND MEDIA GROUP, LLC, ORLANDO, FL, DBA PLAYGROUND MAGAZINE:
4,015,040, PUB. 3-1-2011. INT. CL. 16.
- PLAYPOWER LT FARMINGTON, INC., FARMINGTON, MO:
2,481,823, REN. 7-19-11. INT. CL. 19.
- PLAYTEX PRODUCTS, LLC, SHELTON, CT:
4,016,696, INT. CL. 21.
- PLAYTIME LLC, ENGLEWOOD, CO:
4,015,152, PUB. 6-7-2011. INT. CL. 40.
- PLUNKETT RAYSICH ARCHITECTS, LLP, MILWAUKEE, WI:
4,015,014, PUB. 6-7-2011. INT. CL. 42.
4,015,015, PUB. 6-7-2011. INT. CL. 42.
- PLYMOUTH ROCK ASSURANCE CORPORATION, BOSTON, MA:
4,016,223, MULTIPLE CLASS, INT. CLS. 35, 36, 38 AND 45.
- PM PROTOOLS THE SOURCE, LAS VEGAS, NV:
4,015,951, PUB. 6-7-2011. INT. CL. 8.
- PNEUMAFIL CORPORATION, CHARLOTTE, NC:
1,159,680, REN. 7-21-11. INT. CL. 6.
- PODHEAD.COM, LLC, NARRAGANSETT, RI:
4,015,926, PUB. 6-7-2011. INT. CL. 30.
- POLARIS GLOBAL MARKETING, LLC, FOUNTAIN HILLS, AZ:
4,014,729, PUB. 6-7-2011. MULTIPLE CLASS, INT. CLS. 9 AND 41.
- POLARIS INDUSTRIES INC., MEDINA, MN:
4,015,975, PUB. 6-7-2011. INT. CL. 9.

POLE STAR SPACE APPLICATIONS LIMITED, QUEENSWAY, LONDON W2 4YN, ENGLAND:
2,475,839. REN. 7-19-11. INT. CL. 9.

POLEISH SPORTS, LLC, MOULTONBOROUGH, NH:
4,015,171, PUB. 6-7-2011. INT. CL. 28.

POLICE EXECUTIVE RESEARCH FORUM, WASHINGTON, DC:
2,411,709, CANC. INT. CL. 41.

POLICY DOG, LLC, LARGO, FL:
4,014,824, PUB. 6-7-2011. INT. CL. 36.

POLISHED PEARL GREETINGS INC, BURBANK, CA:
4,017,081, INT. CL. 16.

POLITICS AND PROSE, INC., WASHINGTON, DC:
4,015,351, PUB. 6-7-2011. MULTIPLE CLASS, INT. CLS. 18, 21, 25 AND 35.
4,015,353, PUB. 6-7-2011. MULTIPLE CLASS, INT. CLS. 18, 21, 25 AND 35.

POLO FOOD & WINE GROUP, LLC, AUSTIN, TX:
4,016,932, INT. CL. 43.

POLYCOM, INC., PLEASANTON, CA:
2,910,549, CANC. INT. CL. 38.

POLYMEDCO, INC., CORTLANDT MANOR, NY:
4,016,916, INT. CL. 5.

PONDERA BIOTECHNOLOGIES, LLC, POWNAL, ME:
4,016,751, INT. CL. 5.

PONY, INC., LOS ANGELES, CA:
4,017,103, INT. CL. 9.

POOLHUB, ORMOND BEACH, FL:
2,911,128, CANC. INT. CL. 35.

POPP, EUGEN, MUNICH, FED REP GERMANY AND SAJDA, WOLF E., MUNICH, FED REP GERMANY AND BOHNENBERGER, JOHANNES, MUNICH, FED REP GERMANY AND KRUPIG, VOLKMAR, MUNICH, FED REP GERMANY AND RUPPRECHT, KAY, MUNICH, FED REP GERMANY AND ZECH, STEFAN M., MUNICH, FED REP GERMANY AND HEINZE, EKKEHARD, MUNICH, FED REP GERMANY AND SCHROER, GERNOT H., MUNICH, FED REP GERMANY:
2,958,134, CANC. INT. CL. 41.
2,958,134, AM. INT. CL. 42.

PORTOLANO PRODUCTS, INC., NEW YORK, NY:
4,016,082, PUB. 6-7-2011. INT. CL. 25.
4,016,105, PUB. 6-7-2011. INT. CL. 25.

POSH PALACE, YUCAIPA, CA:
4,015,042, PUB. 6-7-2011. INT. CL. 35.

POST DIVORCE GROUP, LLC, BELLAIRE, TX:
4,017,385, INT. CL. 45.

POSTMAN, RICHARD I., BOCA RATON, FL:
2,909,471, CANC. INT. CL. 28.

POTOS, PETE, CHICAGO, IL:
4,015,226, PUB. 6-7-2011. INT. CL. 25.

POULS, MICHAEL G., GLADWYNE, PA:
2,909,534, CANC. MULTIPLE CLASS, INT. CLS. 16 AND 45.

POWER INTEGRATIONS, INC., SAN JOSE, CA:
3,333,666, AM. INT. CL. 9.

POWER MART CORPORATION, OAK BROOK, IL:
3,259,015, CANC. INT. CL. 3.
3,291,259, CANC. INT. CL. 4.

POWER TECHNOLOGY, INC., HACKENSACK, NJ:
4,014,286, PUB. 6-7-2011. INT. CL. 9.

POWERONE COMMUNICATIONS, LLC, TAVARES, FL:
2,911,403, CANC. MULTIPLE CLASS, INT. CLS. 37 AND 42.

POWERS PRODUCTS III, L.L.C., BREWSTER, NY:
2,466,318. REN. 7-16-11. INT. CL. 6.
2,466,318, CANC. INT. CL. 20.

PQ SILICAS UK LIMITED, WARRINGTON CHESHIRE, UNITED KINGDOM, JOSEPH CROSFIELD & SONS LIMITED, WARRINGTON, ENGLAND:
279,407. REN. 7-15-11. U.S. CL. 6 (INT. CL. 1).

PRACTICAL SYSTEMS LIMITED, NASSAU, BAHAMAS:
4,016,859, INT. CL. 35.

PRAGMATICS, INC., MCLEAN, VA:
4,015,560, PUB. 6-7-2011. INT. CL. 42.

PRAISE BROADCASTING, OSAKIS, MN, AKA PRAISE FM:
4,014,821, PUB. 6-7-2011. INT. CL. 38.

PRATER, ARCHIE LEWIS, JONESBORO, GA, DBA HEART OF A LION:
4,017,275, INT. CL. 25.

PRATT, ALLISON, MISSION VIEGO, CA:
2,909,538, CANC. INT. CL. 9.

PRAXAIR SURFACE TECHNOLOGIES, INC., INDIANAPOLIS, IN:
2,411,635, CANC. MULTIPLE CLASS, INT. CLS. 1 AND 2.

PRE GEL S.P.A., ITALY:
3,079,834.

PRECEPT BRANDS, LLC, SEATTLE, WA:
4,015,502, PUB. 6-7-2011. INT. CL. 33.
4,015,503, PUB. 6-7-2011. INT. CL. 33.
4,015,504, PUB. 6-7-2011. INT. CL. 33.
4,015,505, PUB. 6-7-2011. INT. CL. 33.

PRECISION MACHINING CONNECTION LLC, CLEVELAND, OH, DBA PMC INDUSTRIES:
1,127,412, CANC. INT. CL. 7.

PREFERRED COMMERCE, INC., WEST PALM BEACH, FL:
4,016,815, INT. CL. 31.
4,017,254, INT. CL. 41.

PREMIER DINING INNOVATIONS, LLC, KANSAS CITY, MO:
4,015,676, PUB. 6-7-2011. INT. CL. 29.

PREMIER RESEARCH AND DEVELOPMENT, GIBSONIA, PA:
2,909,788, CANC. INT. CL. 5.

PREMIERE MAINTENANCE CORPORATION, BLOOMFIELD, NJ:
2,911,290, CANC. INT. CL. 37.

PREMIERE RADIO NETWORKS, INC., SAN ANTONIO, TX:
2,531,099. REN. 7-16-11. INT. CL. 35.

PREMIUM NUTRITIONAL PRODUCTS, INC., SHAWNEE, KS:
2,589,678. REN. 7-15-11. INT. CL. 31.

PREPARADOS ALIMENTICIOS, S.A., DE LLOBREGAT, SPAIN:
2,468,051. REN. 7-19-11. INT. CL. 29.

PRESENTATION PRODUCTS, INC., LA MIRADA, CA, DBA SPINITAR:
2,540,362. REN. 7-19-11. MULTIPLE CLASS, INT. CLS. 35, 37 AND 42.

PRESSTEK, INC., HUDSON, NH:
2,513,380. REN. 7-18-11. INT. CL. 7.

PRESTONE PRODUCTS CORPORATION, DANBURY, CT:
2,413,029, CANC. INT. CL. 1.

PREVIZEN SAS, PARIS, FRANCE:
4,015,122, PUB. 6-7-2011. INT. CL. 5.

PRIEST, JAMES BERKLEY, VERNON HILL, VA:
4,014,981, PUB. 6-7-2011. INT. CL. 41.

PRIMA PURETEK CORPORATION, PARAMOUNT, CA:
2,911,175, CANC. INT. CL. 25.

PRIME IMAGE DELAWARE, INC., CHALFONT, DE:
1,689,972. REN. 7-18-11. INT. CL. 9.

PRIMESYS, LP, HOUSTON, TX:
4,015,953, PUB. 6-7-2011. INT. CL. 9.

PRIMETRICA, INC., CARLSBAD, CA:
2,909,886, CANC. INT. CL. 35.

PRIMROSE CANDY COMPANY, CHICAGO, IL:
1,157,499. REN. 7-18-11. INT. CL. 30.

PRIMUS PHARMACEUTICALS, INC., SCOTTSDALE, AZ:
4,015,701, PUB. 6-7-2011. INT. CL. 5.

PRINCE, MARY, HOUSTON, TX, DBA ROOKIES COOKIES:
4,017,123, INT. CL. 30.

PRITCHARD, LISA, CHERRY LOG, GA AND PRITCHARD, BRIAN K., CHERRY LOG, GA:
4,014,735, PUB. 6-7-2011. INT. CL. 41.

PRIVATEWAVE ITALIA S.P.A., ITALY:
4,014,664, PUB. 6-7-2011. MULTIPLE CLASS, INT. CLS. 9, 38 AND 42.

PRL USA HOLDINGS, INC., WILMINGTON, DE:
4,016,199, INT. CL. 3.

PRN FUNDING, LLC, CLEVELAND, OH:
2,555,369. REN. 7-15-11. INT. CL. 36.

PRO TILE DISTRIBUTORS, INC., MOUNT VERNON, NY:
4,014,674, PUB. 6-7-2011. INT. CL. 35.

- PRO-FIT INTERNATIONAL LIMITED, RAWDON, LEEDS LS19 6LG, ENGLAND TO PROFIT INTERNATIONAL LIMITED, ALBION MILLS, BRADFORD, UNITED KINGDOM:
2,412,721, CANC. INT. CL. 40.
- PROACTIVE TRAINING SOLUTIONS, INC., SCOTTSDALE, AZ:
4,015,405, PUB. 6-7-2011. INT. CL. 41.
- PROBOOKS, LLC, HAMPTON BAYS, NY:
4,015,777, PUB. 6-7-2011. INT. CL. 35.
- PROCESSORS CO-OP, INC, ALPHARETTA, GA:
4,014,681, PUB. 6-7-2011. INT. CL. 29.
- PROCTER & GAMBLE COMPANY, THE, CINCINNATI, OH:
2,911,778, CANC. INT. CL. 3.
- PRODIGY DIABETES CARE, LLC, CHARLOTTE, NC:
4,017,233, INT. CL. 10.
- PRODUCERS GUILD OF AMERICA, INC., BEVERLY HILLS, CA:
4,015,153, PUB. 6-7-2011. MULTIPLE CLASS, INT. CLS. 16 AND 41.
- PRODUCT BLISS, LLC, BEVERLY HILLS, CA, FORMERLY WRUG, LLC:
4,016,507, INT. CL. 27.
- PRODOTTORI ITALIANI TESSUTO FILO DI SCOZIA ALTA QUALITA', MILANO, ITALY:
2,910,381, CANC. INT. CL. 25.
- PROFFERO SYSTEMS, INC., DALLAS, NC:
2,511,494, REN. 7-21-11. INT. CL. 7.
2,513,843, REN. 7-18-11. INT. CL. 7.
- PROFESSIONAL OUTDOOR MEDIA ASSOCIATION, JOHNSTOWN, PA:
4,014,842, PUB. 6-7-2011. INT. CL. 35.
- PROFESSIONAL RODEO COWBOYS ASSOCIATION, INC., COLORADO SPRINGS, CO:
4,016,338, INT. CL. 26.
- PROFESSIONAL SYSTEMS ASSOCIATES, INC., PANAMA CITY, FL:
4,015,275, PUB. 6-7-2011. INT. CL. 9.
- PROFORMA INC., VANCOUVER, CANADA:
4,015,786, PUB. 6-7-2011. INT. CL. 36.
- PROGRESS SOFTWARE CORPORATION, BEDFORD, MA:
2,909,842, CANC. INT. CL. 42.
- PROGRESSIVE GROUP ALLIANCE, LLC, RICHMOND, VA:
2,495,599, REN. 7-19-11. MULTIPLE CLASS, INT. CLS. 29, 30 AND 32.
2,495,599, CANC. INT. CL. 35.
- PROJECT S.L.I.D.E (SAVING LIVES IN DANCE EDUCATION), ATLANTA, GA:
4,016,474, INT. CL. 41.
- PROJECTS UNLIMITED, INC., DAYTON, OH:
920,338, REN. 7-15-11. U.S. CL. 100 (INT. CL. 42).
- PROLIANCE MORTGAGE CORPORATION, COLUMBIA, SC:
2,911,524, CANC. INT. CL. 36.
- PROMETHEAN LIMITED, BLACKBURN, LANCASHIRE, UNITED KINGDOM:
4,014,316, PUB. 6-7-2011. MULTIPLE CLASS, INT. CLS. 9, 16, 38, 41 AND 42.
4,014,317, PUB. 6-7-2011. MULTIPLE CLASS, INT. CLS. 9, 16, 38, 41 AND 42.
- PROMETHEUS GLOBAL MEDIA, LLC, NEW YORK, NY, SUNSHINE GROUP WORLDWIDE, LLC, NEW YORK, NY:
2,472,821, REN. 7-19-11. INT. CL. 35.
- PRONUX GMBH, AFFOLTERN AM ALBIS, SWITZERLAND, DBA PRONUX:
4,016,353, INT. CL. 9.
- PROPHYSICS INNOVATIONS, INC., MORRISVILLE, NC:
4,016,022, PUB. 6-7-2011. INT. CL. 41.
- PROTEAN POWER PTY LTD, AUSTRALIA:
3,960,650, COR. MULTIPLE CLASS, INT. CLS. 7, 37, 39, 40 AND 42.
- PROTEMIX CORPORATION LIMITED, AUCKLAND, NEW ZEALAND:
2,909,469, CANC. MULTIPLE CLASS, INT. CLS. 5, 42 AND 44.
- PROVA EDUCATION INC., FORT WASHINGTON, PA:
4,015,974, PUB. 6-7-2011. INT. CL. 41.
- PROVIDE SOURCE, LLC, MASCOUTAH, IL:
4,015,354, PUB. 6-7-2011. INT. CL. 41.
- PROVIDENCE PARTNERS, INC., INDIANAPOLIS, IN:
2,910,908, CANC. MULTIPLE CLASS, INT. CLS. 36 AND 37.
- PROVIDENT MANAGEMENT CORPORATION, CLEARWATER, FL:
2,412,999, CANC. INT. CL. 42.
- PROVIDENT MANAGEMENT CORPORATION, CLEARWATER, FL, DBA SAILPORT WATERFRONT SUITES ON TAMPA BAY:
4,015,983, PUB. 6-7-2011. INT. CL. 43.
- PROXY BIOMEDICAL LIMITED, GALWAY, IRELAND:
4,014,791, PUB. 6-7-2011. MULTIPLE CLASS, INT. CLS. 5, 10 AND 42.
4,014,792, PUB. 6-7-2011. MULTIPLE CLASS, INT. CLS. 5, 10 AND 42.
- PRYMORYS ENVIRONMENTAL CONSULTING, INC., DURANGO, CO:
4,015,878, PUB. 6-7-2011. INT. CL. 42.
4,015,879, PUB. 6-7-2011. INT. CL. 45.
- PSK, INC., GYEONGGI-DO, REPUBLIC OF KOREA:
4,014,295, PUB. 6-7-2011. INT. CL. 7.
- PSS WORLD MEDICAL, INC., JACKSONVILLE, FL:
4,016,261, INT. CL. 35.
4,016,263, INT. CL. 35.
- PT FINANCIAL, LLC, CHICAGO, IL:
4,014,224, PUB. 6-7-2011. INT. CL. 41.
- PUBGENE AS, NORWAY:
4,014,632, PUB. 6-7-2011. MULTIPLE CLASS, INT. CLS. 9 AND 42.
- PUBGET INC, CAMBRIDGE, MA:
4,015,449, PUB. 6-7-2011. INT. CL. 35.
- PUBLIC BROADCASTING SERVICE, ARLINGTON, VA:
4,014,282, PUB. 6-7-2011. INT. CL. 41.
- PUBLIC MEDIA CENTER, SAN FRANCISCO, CA:
2,411,746, CANC. MULTIPLE CLASS, INT. CLS. 35, 36, 41 AND 42.
- PUFFIN PHOTO PRODUCTS, LLC, ORLANDO, FL:
4,015,407, PUB. 6-7-2011. INT. CL. 9.
- PULL'R HOLDING COMPANY, LLC, ELK GROVE VILLAGE, IL:
2,412,443, CANC. INT. CL. 8.
- PULSIN' LTD, KENT, UNITED KINGDOM:
4,015,235, PUB. 6-7-2011. MULTIPLE CLASS, INT. CLS. 5 AND 29.
4,015,236, PUB. 6-7-2011. INT. CL. 30.
- PURCELL, DONALD, JOSEPH, II, NAPA, CA:
2,911,481, CANC. INT. CL. 41.
- PURCHASEPARTY, LLC, MINNEAPOLIS, MN:
4,015,438, PUB. 6-7-2011. INT. CL. 35.
4,015,440, PUB. 6-7-2011. INT. CL. 35.
- PURE + SIMPLE BEAUTY INCORPORATED, TORONTO, CANADA:
4,015,011, PUB. 6-7-2011. INT. CL. 3.
4,015,012, PUB. 6-7-2011. INT. CL. 44.
4,015,013, PUB. 6-7-2011. INT. CL. 35.
- PURE BALANCE FITNESS, L.L.C., SPANISH FORK, UT:
2,910,029, CANC. INT. CL. 41.
- PURE SOURCE, INC., MIAMI, FL:
2,911,169, CANC. INT. CL. 3.
- PUREBEAUTY, INC., TORONTO, ONTARIO, CANADA:
2,411,881, CANC. MULTIPLE CLASS, INT. CLS. 35 AND 42.
- PURESTREAM, INC., WALTON, KY:
1,652,305, REN. 7-18-11. INT. CL. 11.
- PURPOSE JOURNEY, INC., NAPLES, FL:
4,017,224, MULTIPLE CLASS, INT. CLS. 16, 41 AND 42.
- PURSUIT MARKETING, INC., SEWELL, NJ:
2,911,702, CANC. INT. CL. 28.
- PUSH BUTTON LABS, CRESWELL, OR:
4,014,704, PUB. 3-1-2011. INT. CL. 9.
- PUTNAM RETAIL MANAGEMENT, INC., BOSTON, MA TO PUTNAM RETAIL MANAGEMENT, LP:
2,513,241, CANC. INT. CL. 36.
- PUZZLER MEDIA GROUP LIMITED, REDHILL, SURREY, UNITED KINGDOM:
4,015,115, PUB. 6-7-2011. MULTIPLE CLASS, INT. CLS. 9,

- 28 AND 41.
PWP INDUSTRIES, INC., VERNON, CA:
4,014,805, PUB. 6-7-2011. INT. CL. 40.
PYROMATION, INC., FORT WAYNE, IN:
4,015,598, PUB. 6-7-2011. INT. CL. 9.
PZ CUSSONS (INTERNATIONAL) LIMITED, STOCKPORT
CHESHIRE, UNITED KINGDOM:
2,910,711, CANC. INT. CL. 3.
Q-CENTRIX, LLC, MOULTONBOROUGH, NH:
4,015,674, PUB. 6-7-2011. INT. CL. 35.
QELLO LLC, NEW YORK, NY:
4,015,023, PUB. 6-7-2011. MULTIPLE CLASS, INT. CLS. 9
AND 41.
QINGDAO NINE-ALLIANCE GROUP CO.,LTD, LAIXI
CITY, QINGDAO, CHINA:
4,017,070, INT. CL. 29.
QRP, INCORPORATED, TUCSON, AZ:
4,016,858, INT. CL. 9.
QUADION CORPORATION, MINNEAPOLIS, MN, MINNE-
SOTA RUBBER COMPANY, MINNEAPOLIS, MN:
917,508. REN. 7-20-11. U.S. CL. 13 (INT. CLS. 7 AND 17).
922,820. REN. 7-20-11. U.S. CL. 36 (INT. CL. 9).
QUALCOMM ATHEROS, INC., SAN JOSE, CA:
2,911,810, CANC. INT. CL. 9.
QUALCOMM INCORPORATED, SAN DIEGO, CA:
2,911,598, CANC. INT. CL. 9.
QUALIPHARM CONSULTING, INC., WAYNE, PA:
2,910,375, CANC. MULTIPLE CLASS, INT. CLS. 41 AND
42.
QUANTIA COMMUNICATIONS, INC., WALTHAM, MA:
4,016,754, INT. CL. 9.
QUEST INTERNATIONAL BV, GP NAARDEN, NETHER-
LANDS:
2,909,432, CANC. MULTIPLE CLASS, INT. CLS. 1, 3, 5, 29,
30 AND 32.
QUEST INTERNATIONAL SERVICES B.V., 1411 GP NAAR-
DEN, NETHERLANDS:
2,909,488, CANC. MULTIPLE CLASS, INT. CLS. 1, 30
AND 42.
QUIBIDS LLC, OKLAHOMA CITY, OK:
4,015,769, PUB. 6-7-2011. INT. CL. 35.
QUIVER GLOBAL LLC, AURORA, IL:
4,015,373, PUB. 6-7-2011. INT. CL. 16.
QVC, INC., WEST CHESTER, PA:
4,015,070, PUB. 6-7-2011. MULTIPLE CLASS, INT. CLS. 14
AND 35.
QWEST COMMUNICATION INTERNATIONAL INC., DEN-
VER, CO:
2,910,947, CANC. INT. CL. 38.
R. TALSORIAN GAMES INC., REDMOND, NJ:
1,613,055, CANC. INT. CL. 28.
RAASM S.P.A., 36022 SAN ZENO DI CASSOLA (VICENZA),
ITALY:
2,909,748, CANC. MULTIPLE CLASS, INT. CLS. 6, 7, 8
AND 12.
RACEMI SRL, ITALY:
4,014,636, PUB. 6-7-2011. INT. CL. 33.
RACETRACK TELEVISION NETWORK, LLC, LAS VEGAS,
NV:
4,014,908, PUB. 6-7-2011. MULTIPLE CLASS, INT. CLS. 38
AND 41.
RACKOWSKI, CATHY, BEDFORD, MA:
2,910,965, CANC. INT. CL. 14.
RAD COSMETICS LTD., MISSISSAUGA, CANADA:
4,015,187, PUB. 6-7-2011. INT. CL. 3.
RADIAL ASSIST, LLC, ROSWELL, GA:
4,015,589, PUB. 6-7-2011. INT. CL. 10.
RADIOMATIX, NAAMLOZE VENNOOTSCHAP, BELGIUM:
4,014,507, PUB. 6-7-2011. MULTIPLE CLASS, INT. CLS. 9,
42 AND 44.
RAGUSA, ANTHONY J., JR., WILLIAMSVILLE, NY:
4,017,287, INT. CL. 37.
RAHBAR-DEHGHAN, FARIBORZ, CANMORE, CANADA:
4,016,589, INT. CL. 9.
RAIL LOGISTICS, LC, OVERLAND PARK, KS:
4,015,809, PUB. 6-7-2011. MULTIPLE CLASS, INT. CLS. 35
AND 39.
RAINBOW BRIDGE, INC., DENVER, CO:
2,412,593, CANC. INT. CL. 42.
RAINCHECK CORPORATION, OREM, UT, RAINCHECK
CORPORATION, OREM, UT:
2,564,089, REN. 7-16-11. INT. CL. 36.
RAINFOREST NUTRITIONALS, INC., PHOENIX, AZ:
2,911,221, CANC. INT. CL. 5.
RAJA ALESSANDRO, F-75010 PARIS, FRANCE:
4,014,553, PUB. 6-7-2011. MULTIPLE CLASS, INT. CLS. 35
AND 41.
RAKER, JESSE, SAN FRANCISCO CA, CA:
2,910,666, CANC. INT. CL. 25.
RALPH KIMBALL ASSOCIATES, INC., BOULDER CREEK,
CA, DBA KIMBALL GROUP, KIMBALL UNIVERSITY,
RALPH KIMBALL ASSOCIATES:
2,459,259, REN. 7-18-11. INT. CL. 41.
RALPH KIMBALL ASSOCIATES, INC., BOULDER CREEK,
CA:
2,459,261, REN. 7-18-11. INT. CL. 35.
RANCO INDUSTRIES, INC., HOUSTON, TX:
2,584,686, REN. 7-15-11. INT. CL. 27.
RANDALL-BAUER, DANIELLE, CONCORD, NC:
2,464,093, REN. 7-18-11. INT. CL. 41.
RANIR, LLC, GRAND RAPIDS, MI:
4,017,356, INT. CL. 10.
RATHBUN, JOHN M, MILLS RIVER, NC:
4,017,389, INT. CL. 45.
RAVENSBURGER AKTIENGESELLSCHAFT, RAVENS-
BURG 88214, FED REP GERMANY:
3,656,322, COR. MULTIPLE CLASS, INT. CLS. 16 AND
28.
RAYMOND GUBBAY LIMITED, BARNET, UNITED KING-
DOM:
2,910,998, CANC. MULTIPLE CLASS, INT. CLS. 9, 16
AND 41.
RAYTHEON COMPANY, LEXINGTON, MA:
2,485,143, REN. 7-19-11. INT. CL. 42.
RBK, LLC, INDIANAPOLIS, IN:
2,395,824, REN. 7-21-11. INT. CL. 6.
RCI ACQUISITION, LLC, BELTSVILLE, MD:
2,509,769, REN. 7-18-11. INT. CL. 35.
RE FORMSNET, LLC, LOS ANGELES, CA, DBA ZIPLOGIX:
4,016,808, INT. CL. 42.
REAL FOUNDATION, INC., ADDISON, TX:
4,015,694, PUB. 6-7-2011. MULTIPLE CLASS, INT. CLS. 35
AND 36.
4,015,695, PUB. 6-7-2011. MULTIPLE CLASS, INT. CLS. 35
AND 36.
4,015,697, PUB. 6-7-2011. INT. CL. 35.
4,015,700, PUB. 6-7-2011. INT. CL. 35.
REAL-TIME INNOVATIONS, INC., SUNNYVALE, CA:
2,475,069, REN. 7-21-11. INT. CL. 42.
REBEL ROCK PRODUCTIONS, INC., COCONUT CREEK,
FL:
4,015,068, PUB. 6-7-2011. INT. CL. 41.
REBEL WINE CO. LLC, ST. HELENA, CA:
4,016,010, PUB. 6-7-2011. INT. CL. 41.
REBORN BEAUTY, LLC, BALTIMORE, MD:
2,911,202, CANC. INT. CL. 3.
RECIPE CHEMICALS + INSTRUMENTS GMBH, FED REP
GERMANY:
4,014,460, PUB. 6-7-2011. MULTIPLE CLASS, INT. CLS. 1,
5 AND 9.
RECKITT BENCKISER LLC, PARSIPPANY, NJ, R.T.
FRENCH COMPANY, THE, ROCHESTER, NY:
545,030, REN. 7-20-11. U.S. CL. 46 (INT. CLS. 1, 5, 29, 30, 31
AND 32).
RECKITT BENCKISER LLC, PARSIPPANY, NJ:
4,016,755, MULTIPLE CLASS, INT. CLS. 3, 4, 5 AND 11.
RED APPLE AUCTIONS CO., ALEXANDRIA, VA:
4,016,857, MULTIPLE CLASS, INT. CLS. 35 AND 41.
REDDY KILOWATT CORPORATION, MINNEAPOLIS, MN:
2,411,770, CANC. INT. CL. 39.
REDMOND, INCORPORATED, HEBER CITY, UT:
4,015,497, PUB. 6-7-2011. INT. CL. 31.
4,015,498, PUB. 6-7-2011. INT. CL. 31.
REDPUP LLC, SELIGMAN, AZ:
4,016,019, PUB. 6-7-2011. INT. CL. 9.

- REDSEEB, INC., SANTA MONICA, CA:
4,015,291, PUB. 6-7-2011. INT. CL. 35.
- REDXDEFENSE, LLC, ROCKVILLE, MD:
4,014,399, PUB. 6-7-2011. INT. CL. 9.
- REECE, JUDSON B., LINCOLN, MA:
2,412,674, CANC. INT. CL. 9.
- REED ELSEVIER INC., NEWTON, MA:
2,540,631. REN. 7-20-11. INT. CL. 42.
- REENAGH MCCALL, IRELAND:
4,014,624, PUB. 6-7-2011. INT. CL. 25.
- REGEN LAB SA, CH-1052 MONT-SUR-LAUSANNE, SWITZERLAND:
4,014,606, PUB. 6-7-2011. MULTIPLE CLASS, INT. CLS. 3, 5 AND 10.
- REGEN LAB SA, SWITZERLAND:
4,014,612, PUB. 6-7-2011. MULTIPLE CLASS, INT. CLS. 3, 5 AND 10.
- REGEN LAB SA, CH-1052 MONT-SUR-LAUSANNE, SWITZERLAND:
4,014,613, PUB. 6-7-2011. MULTIPLE CLASS, INT. CLS. 3, 5 AND 10.
- REGENT CONFECTIONS, INC., ORLANDO, FL:
2,910,338, CANC. INT. CL. 30.
- REGENTS OF THE UNIVERSITY OF CALIFORNIA, THE, OAKLAND, CA:
2,462,372. REN. 7-21-11. MULTIPLE CLASS, INT. CLS. 16 AND 28.
- REGENTS OF THE UNIVERSITY OF MICHIGAN, ANN ARBOR, MI:
2,411,904, CANC. MULTIPLE CLASS, INT. CLS. 41 AND 42.
- REGIS INC., MINNEAPOLIS, MN:
2,464,369. REN. 7-18-11. INT. CL. 42.
- REIDER, CRAIG A., WHEELING, IL:
4,016,522, MULTIPLE CLASS, INT. CLS. 35 AND 41.
- RELIABLE DELIVERY LLC, SAN DIEGO, CA:
4,015,105, PUB. 6-7-2011. INT. CL. 39.
- RELIABLE KNITTING WORKS, INC., MILWAUKEE, WI, DBA RELIABLE OF MILWAUKEE:
4,015,855, PUB. 6-7-2011. INT. CL. 25.
- RELIANCE INTERNATIONAL CORP., TAIPEI, TAIWAN:
4,017,146, INT. CL. 15.
- REMEI GMBH & CO. KG, BLOMBERG, FED REP GERMANY:
2,910,625, CANC. INT. CL. 1.
- REMONX, LLC, MISSION VIEJO, CA:
4,014,888, PUB. 6-7-2011. INT. CL. 9.
- RENCON ENERGY PRODUCTS INC., HEALDSBURG, CA:
4,014,785, PUB. 6-7-2011. INT. CL. 11.
- RENEW MEDICAL, INC., PALO ALTO, CA:
4,016,550, INT. CL. 5.
- RENTINO CORPORATION, CHEYENNE, WY:
4,015,195, PUB. 6-7-2011. INT. CL. 35.
- REPAR CORPORATION, SILVER SPRING, MD:
4,015,686, PUB. 6-7-2011. INT. CL. 5.
4,015,687, PUB. 6-7-2011. MULTIPLE CLASS, INT. CLS. 1 AND 5.
- REPRESENTATIONS, INC., DARNESTOWN, MD:
2,910,764, CANC. INT. CL. 35.
- REPUBLIC OF COLOMBIA, THE, BOGOTA, COLOMBIA:
1,160,492. REN. 7-18-11. U.S. CL. A.
- REPUBLIC TOBACCO L.P., GLENVIEW, IL, REPUBLIC TOBACCO, INC., CHICAGO, IL:
1,647,612. REN. 7-16-11. INT. CL. 34.
- REQUIREMENTSLIVE LLC, LA JOLLA, CA:
4,015,196, PUB. 6-7-2011. MULTIPLE CLASS, INT. CLS. 35 AND 42.
- RESCO PRODUCTS, INC., PITTSBURGH, PA:
2,910,345, CANC. INT. CL. 19.
- RESEARCH CONNECT, INC., BRIGHTON, MA:
2,910,449, CANC. INT. CL. 42.
- RESMED LIMITED, BELLA VISTA, NSW, AUSTRALIA:
2,910,834, CANC. INT. CL. 10.
- RESONANCE, INC., OKLAHOMA CITY, OK:
4,015,512, PUB. 6-7-2011. INT. CL. 9.
- RESPONSE DESIGN CORPORATION, OCEAN CITY, NJ:
2,411,859, CANC. INT. CL. 16.
2,411,860, CANC. MULTIPLE CLASS, INT. CLS. 16 AND 41.
2,411,861, CANC. MULTIPLE CLASS, INT. CLS. 16 AND 41.
2,411,862, CANC. MULTIPLE CLASS, INT. CLS. 16 AND 41.
- RESSOURCE, A SCHMITT COMPANY, INC., CASTLE ROCK, CO:
2,910,184, CANC. INT. CL. 35.
- RESTAURANT INVESTMENTS, INC., LAMETA, TX:
4,014,690, PUB. 5-3-2011. INT. CL. 43.
- RESTONIC CORPORATION, ANTIOCH, IL:
4,015,905, PUB. 6-7-2011. INT. CL. 20.
- RESTORATION COMMUNITY SERVICES, INC., COLLEGE PARK, GA:
4,015,835, PUB. 6-7-2011. INT. CL. 45.
- RETAIL GROUP OF NEW YORK, INC., PURCHASE, NY:
2,593,154. REN. 7-15-11. INT. CL. 35.
- RETAIL ROYALTY COMPANY, LAS VEGAS, NV:
4,015,234, PUB. 6-7-2011. INT. CL. 35.
4,016,692, INT. CL. 25.
4,016,703, INT. CL. 25.
- RETIREMENT BENEFIT SOLUTIONS, LLC, TRAVERSE CITY, MI:
4,014,746, PUB. 6-7-2011. INT. CL. 36.
- REVELL, ALAN, MILFORD, NJ:
4,015,961, PUB. 6-7-2011. INT. CL. 35.
- REVIVA PHARMACEUTICALS, INC., SAN JOSE, CA:
4,016,184, INT. CL. 42.
- REVLON CONSUMER PRODUCTS CORPORATION, NEW YORK, NY:
2,412,922, CANC. INT. CL. 3.
- REX T. BURDETT, RIVER FOREST, IL:
4,015,957, PUB. 6-7-2011. INT. CL. 9.
- RHEINMETALL W & M GMBH, UNTERLUSS, FED REP GERMANY:
2,910,705, CANC. MULTIPLE CLASS, INT. CLS. 13, 35 AND 42.
- RHEONIX, INC., ITHACA, NY:
4,016,901, INT. CL. 5.
- RHINO LININGS USA, INC., SAN DIEGO, CA:
4,016,670, MULTIPLE CLASS, INT. CLS. 2 AND 40.
- RHITA PEREZ, BEVERLY HILLS, CA:
4,016,394, INT. CL. 25.
- RHOADES, DEAN L., BEVERLY HILLS, CA:
2,911,461, CANC. INT. CL. 3.
- RICA APPAREL LLC, BROOKLYN, NY:
4,015,021, PUB. 6-7-2011. INT. CL. 25.
- RICART PROPERTIES, INC., GROVEPORT, OH:
2,412,418, CANC. INT. CL. 35.
- RICELAND FOODS, INC., STUTTGART, AR:
924,538. REN. 7-20-11. U.S. CL. 1 (INT. CL. 31).
- RICH INVESTMENTS, INC., YORK, PA:
4,016,254, INT. CL. 36.
- RICHEMONT INTERNATIONAL SA, SWITZERLAND:
2,967,266.
- RICHES, MARK, NORWICH, NR4 7QQ, UNITED KINGDOM:
4,014,250, PUB. 2-22-2011. MULTIPLE CLASS, INT. CLS. 9, 10 AND 42.
- RICHFIELD INDUSTRIES, FLINT, MI:
2,456,796. REN. 7-18-11. INT. CL. 40.
- RICHLINE GROUP, INC., NEW YORK, NY, MEDICATED PRODUCTS CO., CHICAGO, IL, DBA DONALD BRUCE & COMPANY:
551,057. REN. 7-20-11. U.S. CL. 28 (INT. CL. 14).
- RICHLINE GROUP, INC., NEW YORK, NY:
2,506,105. REN. 7-19-11. INT. CL. 14.
- RICHMOND INTERNATIONAL RACEWAY, INC., DAYTONA BEACH, FL:
4,015,520, PUB. 6-7-2011. INT. CL. 43.
- RICHMOND SOCIETY FOR THE PREVENTION OF CRUELTY TO ANIMALS, RICHMOND, VA:
2,474,554. REN. 7-19-11. INT. CL. 42.
- RICHMOND, ZOE PATRICIA, BOREHAMWOOD, UNITED KINGDOM:
2,412,376, CANC. INT. CL. 14.

RICHTREE MARKETS INC., TORONTO, ONTARIO, M5H 2G4, CANADA:
 2,911,324, CANC. MULTIPLE CLASS, INT. CLS. 35 AND 42.

RIDEMAKERZ, LLC, IRVINE, CA:
 4,016,904, INT. CL. 28.

RIEDEL SHOES, INC., RED WING, MN:
 4,016,872, INT. CL. 42.
 4,016,873, INT. CL. 42.

RIEDY, ROBERT M., WOODSTOCK, IL:
 2,520,528, REN. 7-16-11, INT. CL. 9.

RIO PRODUCTS INTL., INC., IDAHO FALLS, ID:
 4,015,703, PUB. 6-7-2011, INT. CL. 28.

RIO TINTO LONDON LIMITED, LONDON W2 6LG, UNITED KINGDOM:
 4,014,267, PUB. 6-7-2011, MULTIPLE CLASS, INT. CLS. 35, 37, 38, 39, 40 AND 42.

RITOLA, CATHY, S., ALPHARETTA, GA:
 2,910,623, CANC. MULTIPLE CLASS, INT. CLS. 18 AND 25.

RITZ CAMERA & IMAGE, L.L.C., BELTSVILLE, MD:
 4,014,340, PUB. 5-10-2011, MULTIPLE CLASS, INT. CLS. 35 AND 40.

RIVE, HASTINGS, NE:
 4,016,626, INT. CL. 21.

RIVER VALLEY FOODS, INC., SYRACUSE, NY:
 2,507,961, REN. 7-18-11, INT. CL. 29.

RIVERSET CREDIT UNION, PITTSBURGH, PA:
 4,014,221, PUB. 6-7-2011, MULTIPLE CLASS, INT. CLS. 35 AND 36.

RIVERTEX UK LIMITED, HUNTINGDOM, CAMBS., UNITED KINGDOM:
 4,014,484, PUB. 6-7-2011, MULTIPLE CLASS, INT. CLS. 9, 17 AND 24.

RIVERWIRED, INC., NEW YORK, NY:
 4,016,268, MULTIPLE CLASS, INT. CLS. 35 AND 41.

RIVETING MEDIA, INC., HALF MOON BAY, CA:
 2,445,838, REN. 7-21-11, INT. CL. 42.

RIVIERA GOLF & TENNIS, INC., PACIFIC PALISADES, CA, LAACO, INCORPORATED, LOS ANGELES, CA:
 1,318,331, REN. 7-21-11, INT. CL. 28.

RIZOBACTER ARGENTINA S.A., PERGAMINO, ARGENTINA:
 4,016,921, INT. CL. 44.

RIZZI, RON, BALL GROUND, GA, DBA CARS AND COFFEE, INC.:
 4,015,484, PUB. 6-7-2011, INT. CL. 36.

RK COMPANY, INC., SUN VALLEY, CA:
 2,911,571, CANC. INT. CL. 34.

RLI INSURANCE COMPANY, PEORIA, IL:
 4,015,569, PUB. 6-7-2011, INT. CL. 36.
 4,015,570, PUB. 6-7-2011, INT. CL. 36.

RMC OF ILLINOIS, INC., CHICAGO, IL:
 2,412,662, CANC. INT. CL. 35.

RMG OF AIRPORT, INC., NORCROSS, GA:
 2,413,145, CANC. INT. CL. 42.

ROBBIE MANUFACTURING, INC., LENEXA, KS:
 4,016,641, INT. CL. 40.
 4,016,642, INT. CL. 40.

ROBERT COSTELLO ARMSTRONG, ITALY:
 4,014,587, PUB. 6-7-2011, INT. CL. 43.

ROBERT J. GUMNIT, MINNEAPOLIS, MN:
 2,460,559, REN. 7-15-11, MULTIPLE CLASS, INT. CLS. 41, 42 AND 44.

ROBERT K. HANEY, BOULDER, CO AND JENNIFER M. HANEY, BOULDER, CO:
 4,016,313, INT. CL. 35.

ROBERT W. PATRAW, PH.D., MONMOUTH JUNCTION, NJ, DBA FOCAL POINT CONSULTING:
 4,014,434, PUB. 6-7-2011, INT. CL. 35.

ROBERTS, JONATHAN, FRISCO, TX:
 4,016,196, INT. CL. 20.

ROBINSON, TRAVIS, LOVELAND, OH, DBA CASH ROBINSON CLOTHING CO.:
 4,016,527, INT. CL. 25.

ROCK AND ROLL MAN, INC., BALTIMORE, MD:
 2,411,975, CANC. INT. CL. 41.

ROCK TAMERS, LLC, MONUMENT, CO:
 4,015,943, PUB. 6-7-2011, INT. CL. 12.
 4,015,945, PUB. 6-7-2011, INT. CL. 12.
 4,015,946, PUB. 6-7-2011, INT. CL. 12.
 4,015,947, PUB. 6-7-2011, INT. CL. 12.

ROCKEFELLER & CO., INC., NEW YORK, NY:
 4,016,607, MULTIPLE CLASS, INT. CLS. 35 AND 36.

ROCKET21 ENTERPRISES, LLC, FAIRFIELD, CT:
 4,016,457, INT. CL. 45.

ROCKING J RANCH, LLC, PHILIPSBURG, MT:
 4,015,677, PUB. 6-7-2011, MULTIPLE CLASS, INT. CLS. 41, 43 AND 44.

ROCKTONIC CORPORATION, RENO, NV:
 2,910,445, CANC. INT. CL. 43.

ROCKY MOUNTAIN ATV, INC., PAYSON, UT:
 4,015,865, PUB. 6-7-2011, INT. CL. 12.

RODALE INC., EMMAUS, PA:
 4,016,068, PUB. 6-7-2011, INT. CL. 41.
 4,016,073, PUB. 6-7-2011, MULTIPLE CLASS, INT. CLS. 41 AND 44.

RODGERS BUILDERS, INC., CHARLOTTE, NC:
 2,509,970, REN. 7-19-11, INT. CL. 37.

RODMAN PUBLISHING CORP., RAMSEY, NJ:
 4,014,940, PUB. 6-7-2011, INT. CL. 16.

RODOV, ALEX, TORONTO, CANADA:
 4,015,348, PUB. 6-7-2011, INT. CL. 42.
 4,015,366, PUB. 6-7-2011, INT. CL. 42.

RODRIGUEZ, ADALBERTO CANO, SALIDA, CO:
 2,911,750, CANC. INT. CL. 12.

ROGUE DIGITAL, LLC, WEST HOLLYWOOD, CA:
 2,407,553, REN. 7-18-11, MULTIPLE CLASS, INT. CLS. 35 AND 41.

ROHM AND HAAS CHEMICALS LLC, PHILADELPHIA, PA:
 2,502,672, REN. 7-21-11, INT. CL. 1.

ROHM AND HAAS COMPANY, PHILADELPHIA, PA, RESINOUS PRODUCTS & CHEMICAL COMPANY; THE, PHILADELPHIA, PA:
 390,787, REN. 7-18-11, U.S. CL. 6 (INT. CLS. 1, 2, 3, 4 AND 5).

ROLLINSON, PHILIP GARRETT, RALEIGH, NC:
 4,014,822, PUB. 6-7-2011, INT. CL. 41.

ROMAR INTERNATIONAL CORP., NEW YORK, NY:
 2,411,952, CANC. MULTIPLE CLASS, INT. CLS. 10, 18 AND 25.

ROMARO 2000 LIMITED, ST. VICTOR, QUEBEC, CANADA:
 2,909,371, CANC. INT. CL. 19.

RON RIZZI, BALL GROUND, GA, DBA CARS AND COFFEE, INC.:
 4,015,850, PUB. 6-7-2011, INT. CL. 36.
 4,015,851, PUB. 6-7-2011, INT. CL. 36.

RONA INC., BOUCHERVILLE, QUEBEC J4B 8H7, CANADA:
 2,909,397, CANC. MULTIPLE CLASS, INT. CLS. 3 AND 35.

RONALD L. WOOLLEY, PROVO, UT:
 4,017,096, MULTIPLE CLASS, INT. CLS. 30 AND 43.

RONDEROS NEUROSURGERY CENTER, LLC, MOBILE, AL:
 4,015,737, PUB. 6-7-2011, INT. CL. 44.

ROSADIUK, KIMBERLY N, SPRUCE GROVE, CANADA, AKA MORSE CODE DEZYNZ LTD.:
 4,015,729, PUB. 6-7-2011, INT. CL. 25.

ROSE & WALKER DRYWALL AND INSULATION, BLOOMINGTON, IN:
 2,479,749, REN. 7-15-11, INT. CL. 35.

ROSE ACRE FARMS, INC., SEYMOUR, IN:
 4,016,657, INT. CL. 5.
 4,016,658, INT. CL. 5.
 4,016,659, INT. CL. 5.
 4,016,664, INT. CL. 5.

ROSEN HOTELS AND RESORTS, INC., ORLANDO, FL:
 4,015,557, PUB. 6-7-2011, INT. CL. 43.

ROSETTA STONE LTD., HARRISONBURG, VA:
 4,016,236, INT. CL. 9.

ROSSIGNOL SKI COMPANY, INC., WILLISTON, VT:
 2,911,559, CANC. INT. CL. 28.

ROSSMANN, RALF, HOCKENHEIM, FED REP GERMANY:
 4,014,803, PUB. 6-7-2011, MULTIPLE CLASS, INT. CLS. 18 AND 25.

- ROTAM AGROCHEM INTERNATIONAL CO. LTD., CHAI WAN, HONG KONG:
4,016,406, INT. CL. 5.
- ROTKÄPPCHEN-MUMM SEKTKELLEREIEN GMBH, FED REP GERMANY:
4,014,508, PUB. 6-7-2011. INT. CL. 33.
- ROUNDEDCUBE, INC., ST. LOUIS, MO:
2,911,817, CANC. INT. CL. 35.
- ROVI TECHNOLOGIES CORPORATION, SANTA CLARA, CA:
4,014,815, PUB. 6-7-2011. INT. CL. 42.
- ROWE & ASSOCIATES DENTAL CARE, PLLC, PEORIA, AZ:
4,015,915, PUB. 6-7-2011. INT. CL. 44.
- ROWPOWER, INC, TUCSON, AZ:
2,411,845, CANC. MULTIPLE CLASS, INT. CLS. 9, 40 AND 42.
- ROYAL COPENHAGEN A/S, 2600 GLOSTRUP, DENMARK:
2,909,867, CANC. INT. CL. 21.
- ROYAL EHF, ICELAND:
4,014,453, PUB. 6-7-2011. MULTIPLE CLASS, INT. CLS. 9 AND 38.
- ROYAL OAK MINI STORAGE, LLC, ROYAL OAK, MI, DBA ROYAL OAK STORAGE:
4,014,732, PUB. 6-7-2011. MULTIPLE CLASS, INT. CLS. 35 AND 39.
- ROYAL PAPER PRODUCTS, INC., COATESVILLE, PA:
4,016,636, MULTIPLE CLASS, INT. CLS. 3, 8, 20, 21 AND 26.
4,016,637, MULTIPLE CLASS, INT. CLS. 3, 8, 20, 21 AND 26.
- ROYALTY, MARSHALL, DELAND, FL:
4,015,468, PUB. 6-7-2011. INT. CL. 35.
- RS LIGHTING SERVICES, INC., LAWRENCEVILLE, GA:
4,014,847, PUB. 6-7-2011. INT. CL. 37.
- RSA 1 LIMITED PARTNERSHIP, EMERSON, IA AND IOWA
RSA 2 LIMITED PARTNERSHIP, EMERSON, IA:
4,017,294, MULTIPLE CLASS, INT. CLS. 9 AND 38.
- RSR ELECTRONICS, AVENEL, NJ:
4,016,598, INT. CL. 9.
- RUBIN, I SAMSON, IRVINE, CA:
4,015,371, PUB. 6-7-2011. INT. CL. 35.
- RUBIN, OLIVIA, LONDON, UNITED KINGDOM AND RUBIN, DANIEL, LONDON, UNITED KINGDOM:
4,014,809, PUB. 6-7-2011. INT. CL. 25.
- RUBINSTEIN, ALEC, LOS ANGELES, CA:
2,411,947, CANC. INT. CL. 35.
- RUDEN MCCLOSKEY P.A., FORT LAUDERDALE, FL 33301, FL:
2,570,306, REN. 7-15-11. MULTIPLE CLASS, INT. CLS. 41 AND 42.
- RUDIN, DALE M, COLUMBIA, TN:
4,017,403, INT. CL. 41.
- RUFO, MATTHEW A., FRAMINGHAM, MA:
4,014,213, PUB. 6-7-2011. INT. CL. 29.
- RUGSMART, INC., NORCROSS, GA:
2,911,234, CANC. INT. CL. 35.
- RUIZ, SONIA, PASADENA, TX:
2,412,956, CANC. INT. CL. 25.
- RULES-BASED MEDICINE, INC., AUSTIN, TX:
4,016,545, INT. CL. 44.
- RUNNING MOMS ROCK LLC, FLOWER MOUND, TX:
4,014,903, PUB. 6-7-2011. INT. CL. 41.
- RUOCCHIO, ALBERT C, RALEIGH, NC:
2,911,228, CANC. INT. CL. 28.
2,911,229, CANC. INT. CL. 28.
- RURAL SOUTHERN VOICE FOR PEACE, BURNSVILLE, NC:
4,014,998, PUB. 6-7-2011. INT. CL. 41.
- RUSSELL BRANDS, LLC, ALEXANDER CITY, AL:
2,911,114, CANC. INT. CL. 25.
4,016,332, INT. CL. 28.
- RUTHERFORD CONTROLS INT'L CORP., VIRGINIA BEACH, VA:
2,909,611, CANC. INT. CL. 9.
- RUVALCABA LARA, CELIA ALEJANDRA, MEXICO D.F., MEXICO:
4,014,695, PUB. 6-7-2011. INT. CL. 5.
- RYAN TELEMEDICINE, LLC, COSTA MESA, CA:
2,910,120, CANC. INT. CL. 10.
- S. TOUS, S.L., SPAIN:
4,014,527, PUB. 6-7-2011. MULTIPLE CLASS, INT. CLS. 18 AND 25.
- S.D. WARREN COMPANY, BOSTON, MA, DBA SAPPY FINE PAPER NORTH AMERICA:
4,015,848, PUB. 6-7-2011. MULTIPLE CLASS, INT. CLS. 35, 41 AND 42.
- S.R.B. CONVENTION & CATERING CORP., BETHPAGE, NY:
2,909,862, CANC. INT. CL. 43.
- S.U.K. BETEILIGUNGS GMBH, AUSTRIA:
4,014,457, PUB. 6-7-2011. MULTIPLE CLASS, INT. CLS. 5, 29 AND 30.
- SÜD-CHEMIE AG, 80333 MÜNCHEN, FED REP GERMANY:
4,014,292, PUB. 7-6-2010. MULTIPLE CLASS, INT. CLS. 1, 37 AND 42.
- SABIAN, LTD., MEDUCTIC, NB, CANADA:
2,443,950, REN. 7-20-11. INT. CL. 15.
- SABIC INNOVATIVE PLASTICS IP B.V., BERGEN OP ZOOM, NETHERLANDS:
2,483,504, REN. 7-18-11. INT. CL. 40.
- SABMD, LLC, MANASSAS, VA:
2,909,587, CANC. INT. CL. 35.
2,909,588, CANC. INT. CL. 35.
- SACMI COOPERATIVA MECCANICI IMOLA; SOCIETA' COOPERATIVA, ITALY:
4,014,450, PUB. 6-7-2011. INT. CL. 7.
- SACRED ESSENCE ENTERPRISES LLC, SANTA ANA, CA:
4,015,782, PUB. 6-7-2011. INT. CL. 45.
4,015,807, PUB. 6-7-2011. INT. CL. 3.
- SADORU GROUP, LTD., DELAWARE, OH:
4,016,597, INT. CL. 12.
- SAFARILAND, LLC, JACKSONVILLE, FL:
4,015,939, PUB. 6-7-2011. INT. CL. 13.
- SAFEMINE AG, SCHWYZ, SWITZERLAND:
4,017,373, MULTIPLE CLASS, INT. CLS. 9 AND 39.
- SAFESHOT TECHNOLOGIES, LLC, MISSION VIEJO, CA:
4,016,340, INT. CL. 10.
- SAFETY CORPORATION OF AMERICA, COMMERCE CITY, CO:
2,910,315, CANC. INT. CL. 19.
- SAGE SOFTWARE, INC., IRVINE, CA:
2,910,631, CANC. INT. CL. 9.
- SAITEX INTERNATIONAL INC., NEW YORK, NY:
4,016,568, INT. CL. 25.
- SAKATA RICE SNACKS AUSTRALIA PTY LTD., LAVERTON NORTH, AUSTRALIA:
2,910,374, CANC. INT. CL. 30.
- SALAMANDER GRAPHIX, INC., WATSONVILLE, CA:
2,910,639, CANC. INT. CL. 11.
- SALAS, JOEL, NORTH BERGEN, NJ:
4,015,385, PUB. 6-7-2011. INT. CL. 44.
- SALTWATER ZAPF CO., KINGSTON, WA:
4,015,243, PUB. 6-7-2011. INT. CL. 16.
- SALZANO, KATHLEEN, SAN DIEGO, CA:
2,911,714, CANC. MULTIPLE CLASS, INT. CLS. 16 AND 41.
2,911,715, CANC. MULTIPLE CLASS, INT. CLS. 16 AND 41.
- SAMAR COMPANY, INC., STOUGHTON, MA:
4,015,409, PUB. 6-7-2011. INT. CL. 7.
- SAMICK MUSIC CORPORATION, GALLATIN, TN:
2,909,909, CANC. INT. CL. 15.
- SAMJIN GLOBALNET CO., LTD., SEOUL, REPUBLIC OF KOREA:
4,014,989, PUB. 6-7-2011. INT. CL. 32.
- SAMSON MANUFACTURING CORP., WHATELY, MA:
4,014,268, PUB. 6-7-2011. INT. CL. 13.
- SAMSONITE IP HOLDINGS S.A.R.L., LUXEMBOURG, LUXEMBOURG:
2,412,942, CANC. INT. CL. 24.
- SAMSUNG ELECTRONICS CO., LTD., SUWON-SI, GYEONGGI-DO, REPUBLIC OF KOREA:
2,909,545, CANC. INT. CL. 9.
- SAMTEC INC., NEW ALBANY, IN:
4,015,515, PUB. 6-7-2011. INT. CL. 9.

SAN ANTONIO SPURS, L.L.C., SAN ANTONIO, TX:
2,534,168, REN. 7-20-11. INT. CL. 35.

SAN FRANCISCO BASEBALL ASSOCIATES L.P., SAN FRANCISCO, CA, SAN FRANCISCO GIANTS, SAN FRANCISCO, CA:
1,661,650, REN. 7-15-11. MULTIPLE CLASS, INT. CLS. 16 AND 25.

SANCHEZ COMPUTER ASSOCIATES, INC., MALVER, PA:
2,909,451, CANC. MULTIPLE CLASS, INT. CLS. 9, 35, 36 AND 42.

SANCHEZ, MAYA, 7290 SAMOIS SUR SEINE, FRANCE AND SANCHEZ, THIERRY, 7290 SAMOIS SUR SEINE, FRANCE:
2,909,383, CANC. MULTIPLE CLASS, INT. CLS. 9, 16, 18, 25, 28, 35, 38 AND 41.

SANDCASTLE HOSPITALITY INCORPORATED, NAPLES, FL:
4,015,026, PUB. 3-1-2011. INT. CL. 35.

SANDEEP DIAMOND CORPORATION, NEW YORK, NY:
4,015,463, PUB. 6-7-2011. INT. CL. 14.

SANDRA DEIRMENJIAN DDS, INC., PANORAMA CITY, CA, DBA DENTAL WONDERLAND:
4,015,374, PUB. 6-7-2011. INT. CL. 44.

SANDRA E BONGART, BORDENTOWN, NJ, DBA ADORN BEAUTY CENTER & SPA:
4,015,197, PUB. 6-7-2011. INT. CL. 44.

SANFORD, FARGO, ND:
4,015,976, PUB. 6-7-2011. INT. CL. 44.
4,015,984, PUB. 6-7-2011. INT. CL. 44.
4,015,995, PUB. 6-7-2011. INT. CL. 41.

SANG BAE HAN, DENVER, CO:
4,017,302, INT. CL. 1.

SANGUINE ENTERPRISES, LLC, SEVERNA PARK, MD:
4,017,173, INT. CL. 25.

SANOFI-AVENTIS, 75013 PARIS, FRANCE:
2,412,260, CANC. INT. CL. 5.
2,909,394, CANC. INT. CL. 5.
2,910,745, CANC. INT. CL. 5.

SANOFI-AVENTIS, PARIS, FRANCE:
3,985,088, COR. INT. CL. 10.
3,985,089, COR. INT. CL. 10.
3,985,091, COR. INT. CL. 10.
3,985,092, COR. INT. CL. 10.
3,985,093, COR. INT. CL. 10.

SANTA BARBARA CERAMIC DESIGN, BRIDGEWATER, NJ:
2,909,905, CANC. INT. CL. 21.

SANTA BARBARA OLIVE COMPANY, INC., GOLETA, CA:
2,910,829, CANC. INT. CL. 29.

SANTA ROSA CONSULTING, INC., BLOOMFIELD HILLS, MI:
4,015,641, PUB. 6-7-2011. INT. CL. 42.

SANTILLANA, ANDY, SANTA ROSA, CA:
4,017,059, INT. CL. 25.

SARAH VEDELER ENTERPRISES, LLC, SCOTTSDALE, AZ:
4,015,433, PUB. 6-7-2011. INT. CL. 9.

SARAL, AYLIN, ISTANBUL, TURKEY:
2,910,331, CANC. INT. CL. 24.

SARE, MICHELE V., HALL, MT, DBA NURSES FOR NURSES INTERNATIONAL:
4,016,853, MULTIPLE CLASS, INT. CLS. 35 AND 41.

SAS FAYA, F-14117 TRACY SUR MER, FRANCE:
4,014,518, PUB. 6-7-2011. MULTIPLE CLASS, INT. CLS. 12, 16 AND 25.

SATCO PRODUCTS, INC., BRENTWOOD, NY:
2,469,529, REN. 7-15-11. INT. CL. 11.

SAUTTER CRANE RENTAL, INC., PHILADELPHIA, PA:
4,014,345, PUB. 6-7-2011. MULTIPLE CLASS, INT. CLS. 37 AND 39.

SAVELIFE BIOSCIENCE CO., LTD., SHITUEN CHIU, TAI-CHUNG, TAIWAN:
2,911,521, CANC. INT. CL. 5.

SAVKIN, ALEKSEY, SERPUKHOV, RUSSIAN FED.:
4,017,321, INT. CL. 9.

SAVORY CREATIONS INTERNATIONAL, SAN MATEO, CA:
4,017,113, INT. CL. 29.

SAWYER, MICHAEL W., GLEN ELLYN, IL:
2,911,032, CANC. INT. CL. 42.

SAXOTECH A/S, DK-9000 AALBORG, DENMARK:
2,411,784, CANC. INT. CL. 9.

SAZERAC COMPANY, INC., NEW ORLEANS, LA:
2,910,075, CANC. INT. CL. 33.

SCANAVO A/S, DK-2630 TAASTRUP, DENMARK:
2,909,561, CANC. INT. CL. 9.

SCARBOROUGH, CHANDLER, VIRGINIA BEACH, VA:
2,910,346, CANC. INT. CL. 36.

SCENAR HEALTH USA LLC, LAS VEGAS, NV:
4,014,375, PUB. 6-7-2011. INT. CL. 41.

SCENTRIC, INC., DULUTH, GA:
3,149,732, CANC. INT. CL. 9.

SCHELLING, CHRISTIANNE, THREE RIVERS, CA:
2,911,277, CANC. INT. CL. 18.

SCHENCK PROCESS GMBH, FED REP GERMANY AND CARL SCHENCK AG, FED REP GERMANY:
4,014,452, PUB. 6-7-2011. MULTIPLE CLASS, INT. CLS. 6, 7, 9, 11, 12, 20 AND 42.

SCHERING-PLOUGH HEALTHCARE PRODUCTS, INC., MEMPHIS, TN:
2,412,090, CANC. INT. CL. 25.

SCHIFF NUTRITION INTERNATIONAL, INC., SALT LAKE CITY, UT:
2,551,747, REN. 7-15-11. INT. CL. 5.
2,551,748, REN. 7-15-11. INT. CL. 5.

SCHIOLDAN, KIM, HENDERSON, NV:
4,016,537, INT. CL. 9.

SCHIRMER, MICHAELA, D-83088 KIEFERSFELDEN, FED REP GERMANY:
2,909,901, CANC. MULTIPLE CLASS, INT. CLS. 9, 16, 18, 25, 26 AND 35.

SCHNEIDER, JEFFREY, PITTSFIELD, MA:
4,014,896, PUB. 2-1-2011. INT. CL. 41.

SCHOLARSHIP AMERICA, INC., ST. PETER, MN:
4,015,008, PUB. 6-7-2011. MULTIPLE CLASS, INT. CLS. 36 AND 41.

SCHOLASTIC INC., NEW YORK, NY:
2,592,654, REN. 7-18-11. INT. CL. 28.
4,015,032, PUB. 6-7-2011. INT. CL. 41.

SCHOOL SPECIALTY, INC., APPLETON, WI:
4,016,804, MULTIPLE CLASS, INT. CLS. 9, 39 AND 42.

SCHOOLDISCO.COM LTD., SYDENHAM, UNITED KINGDOM:
2,910,263, CANC. MULTIPLE CLASS, INT. CLS. 9, 38 AND 41.

SCHOTT AG, FED REP GERMANY:
3,950,008, COR. MULTIPLE CLASS, INT. CLS. 12, 19 AND 21.

SCHOTT ORTHOPÄDIE-SCHUHTECHNIK GMBH & CO. KG, FED REP GERMANY:
3,882,700, CANC. INT. CL. 9.

SCHUBERT, TIMOTHY DAVID, BEAVERTON, OR:
2,909,888, CANC. INT. CL. 12.

SCHULTZ, DOUGLAS JAMES, OAKLAND PARK, FL:
4,016,775, INT. CL. 9.
4,016,776, INT. CL. 9.

SCHULZ, RANDY S., COLORADO SPRINGS, CO:
2,910,207, CANC. INT. CL. 7.

SCHWAN'S IP, LLC, MARSHALL, MN:
2,911,636, CANC. INT. CL. 30.

SCHWARZ KITCHEN SELECTION SA, SWITZERLAND:
3,035,983.

SCHWEGMAN, LUNDBERG & WOESSNER, P.A., MINNEAPOLIS, MN:
4,016,398, INT. CL. 45.

SCHWING AMERICA, INC., WHITE BEAR LAKE, MN:
4,016,151, INT. CL. 9.

SCI MANAGEMENT L.P., HOUSTON, TX:
2,590,414, REN. 7-21-11. MULTIPLE CLASS, INT. CLS. 36 AND 42.

SCIAMMA, FREDERIC, IBIZA, SPAIN:
4,014,348, PUB. 6-7-2011. MULTIPLE CLASS, INT. CLS. 7, 35 AND 38.

- SCIENCE APPLICATIONS INTERNATIONAL CORPORATION, SAN DIEGO, CA TO VENTYX INC., ATLANTA, GA:
2,411,672, CANC. INT. CL. 9.
- SCIENTIFIC BIO-LOGICS, INC., COSTA MESA, CA:
4,016,004, PUB. 6-7-2011. INT. CL. 5.
4,016,012, PUB. 6-7-2011. INT. CL. 5.
- SCIMED LIFE SYSTEMS, INC., MAPLE GROVE, MN:
2,470,049. REN. 7-19-11. INT. CL. 4.
- SCISSOR HAPPY BY LZZY, LLC, WINDSOR, PA:
4,016,785, INT. CL. 14.
- SCIULLI DIGITAL MEDIA GROUP, INC., MILL VALLEY, CA:
4,016,711, INT. CL. 42.
- SCOLIOSIS SOS LIMITED, WOODBRIDGE, UNITED KINGDOM:
4,014,398, PUB. 12-7-2010. INT. CL. 44.
- SCORE INTERNATIONAL, CALABASAS, CA:
1,168,724. REN. 7-18-11. INT. CL. 41.
- SCOTT KAY, INC., TEANECK, NJ:
4,016,508, INT. CL. 14.
4,016,509, INT. CL. 14.
- SCOTT OFFICE SYSTEMS, LLC, FLORHAM PARK, NJ:
1,631,612. REN. 7-19-11. INT. CL. 17.
- SCOTT SULZER, LOS ANGELES, CA, DBA THE SANDWICH JOINT:
4,017,404, INT. CL. 43.
- SCOTT, RAY L., TUCSON, AZ:
2,910,186, CANC. INT. CL. 28.
- SCOTTSDALE LEAGUE FOR THE ARTS, SCOTTSDALE, AZ:
4,015,293, PUB. 6-7-2011. INT. CL. 41.
- SCRIPPS, ELIZABETH, PITTSBURGH, PA:
4,017,392, INT. CL. 41.
- SCULLY SPORTSWEAR, INC., OXNARD, CA:
4,017,198, INT. CL. 25.
- SDI HEALTH LLC, PLYMOUTH MEETING, PA:
4,014,353, PUB. 6-7-2011. MULTIPLE CLASS, INT. CLS. 42 AND 44.
- SEA CLIFF VENTURES INC., SWIEQI, MALTA:
4,017,257, INT. CL. 45.
- SEABURY & SMITH, INC., NEW YORK, NY:
2,412,270, CANC. INT. CL. 36.
- SEAGATE TECHNOLOGY LLC, SCOTTS VALLEY, CA:
2,911,813, CANC. INT. CL. 35.
- SEALORD GROUP LIMITED, NELSON, NEW ZEALAND:
2,910,837, CANC. INT. CL. 29.
- SEALS, MELVIN, SAN FRANCISCO, CA:
4,015,149, PUB. 6-7-2011. INT. CL. 41.
- SEAN SOLO LLC, DENVER, CO:
4,015,897, PUB. 6-7-2011. INT. CL. 5.
- SEARCHLIGHT CAPITAL PARTNERS, L.P., NEW YORK, NY:
4,016,935, INT. CL. 36.
4,016,936, INT. CL. 36.
- SEARLES, STEVEN B., MAMMOTH LAKES, CA, DBA THE BEAR WHISPERER:
4,015,424, PUB. 6-7-2011. INT. CL. 25.
- SEARS BRANDS, LLC, HOFFMAN ESTATES, IL:
4,014,794, PUB. 6-7-2011. INT. CL. 41.
4,016,471, MULTIPLE CLASS, INT. CLS. 36, 37 AND 38.
- SEASCAPE PRESS, LTD., SANTA BARBARA, CA:
2,412,000, CANC. INT. CL. 41.
- SEB S.A., F - 69130 ECULLY, FRANCE:
4,014,425, PUB. 3-15-2011. MULTIPLE CLASS, INT. CLS. 9, 38 AND 42.
- SECKENCE INC, VISTA, CA:
4,015,548, PUB. 6-7-2011. INT. CL. 25.
- SECURTEST, INC., TAMPA, FL:
4,014,248, PUB. 6-7-2011. INT. CL. 45.
- SEEKDATA, INC., KISSIMMEE, FL:
2,909,499, CANC. MULTIPLE CLASS, INT. CLS. 9 AND 16.
- SEGLER ENTERPRISES, LTD., HOUSTON, TX:
2,910,362, CANC. INT. CL. 44.
- SELCO COMMUNITY CREDIT UNION, EUGENE, OR:
2,910,447, CANC. INT. CL. 36.
- SELECT ARTISTS ASSOCIATES, LLC, SCOTTSDALE, AZ:
2,555,699. REN. 7-19-11. INT. CL. 41.
2,569,879. REN. 7-19-11. INT. CL. 41.
- SELF AWARENESS TRAININGS LLC, SYLMAR, CA:
4,016,331, INT. CL. 41.
- SELLINGER, ARTHUR B., SOUTHLAKE, TX:
2,911,585, CANC. INT. CL. 41.
- SELLSTROM MANUFACTURING COMPANY, PALATINE, IL:
2,467,350. REN. 7-15-11. INT. CL. 9.
- SELMONT, GEORGE A., MIDDLE HADDAM, CT:
4,016,805, INT. CL. 42.
- SENETAS CORPORATION LIMITED, MELBOURNE, AUSTRALIA:
4,014,465, PUB. 6-7-2011. MULTIPLE CLASS, INT. CLS. 9 AND 42.
- SENSUS SPECTRUM LLC, RALEIGH, NC:
1,648,038. REN. 7-16-11. INT. CL. 9.
1,650,036. REN. 7-16-11. INT. CL. 9.
- SENTINEL SOLUTIONS INCORPORATED, HILLSBOROUGH, NJ:
2,911,555, CANC. INT. CL. 44.
- SEPARATION BY DESIGN, INC., EVANSVILLE, IN:
4,016,392, INT. CL. 7.
- SERGE IMPORT LLC, MANALAPAN, NJ:
4,015,470, PUB. 6-7-2011. INT. CL. 33.
- SERRV INTERNATIONAL, NEW WINDSOR, MD:
2,501,252. REN. 7-19-11. INT. CL. 42.
- SERTA, INC., HOFFMAN ESTATES, IL:
2,911,630, CANC. INT. CL. 20.
- SERVAL & ASSOCIÉS, 75116 PARIS, FRANCE:
4,015,564, PUB. 6-7-2011. INT. CL. 35.
- SERVICE COMPANY SOLUTIONS, LLC, BEDFORD, NH:
4,017,072, INT. CL. 16.
- SERVICE EXCELLENCE TRAINING, KYLE, TX:
4,017,239, INT. CL. 41.
- SERVICE-NOW.COM, SOLANA BEACH, CA:
4,015,461, PUB. 6-7-2011. INT. CL. 42.
- SERVICOURCE, INC., ALEXANDRIA, VA, SERVICE-SOURCE, INC., ALEXANDRIA, VA:
2,566,739. REN. 7-21-11. MULTIPLE CLASS, INT. CLS. 35, 41 AND 42.
- SETH ELLIS CHOCOLATIER, LLC, BOULDER, CO:
4,015,573, PUB. 6-7-2011. INT. CL. 30.
- SETH R. COAN, ATLANTA, GA:
4,015,615, PUB. 6-7-2011. INT. CL. 35.
- SEVIGNY, ROGER, HENDERSONVILLE, TN:
4,015,311, PUB. 6-7-2011. INT. CL. 35.
- SF INVESTMENTS, INC., WILMINGTON, DE, P. D. GWALTNEY, JR. & CO. INC., SMITHFIELD, VA:
384,542. REN. 7-15-11. U.S. CL. 46 (INT. CLS. 1, 5, 29, 30, 31 AND 32).
- SGC HORIZON, LLC, ARLINGTON HEIGHTS, IL, REED PUBLISHING (USA) INC., NEWTON, MA:
1,648,117. REN. 7-16-11. INT. CL. 16.
- SGM BIOTECH, INC., BOZEMAN, MT:
4,014,851, PUB. 6-7-2011. INT. CL. 9.
- SHAH, DEVAN, PICO RIVERA, CA:
4,014,438, PUB. 6-7-2011. MULTIPLE CLASS, INT. CLS. 30, 35 AND 43.
- SHALOM LEVYTAM, LONDON, ONTARIO, CANADA:
4,015,820, PUB. 6-7-2011. INT. CL. 41.
- SHANAHAN, KEITH E., NORTH PALM BEACH, FL:
4,017,293, INT. CL. 35.
- SHANDONG GOLDEN LUYANG HEAVY INDUSTRY CO., LTD., SHANDONG, CHINA:
4,014,597, PUB. 6-7-2011. INT. CL. 6.
- SHANGHAI GIANT NETWORK TECHNOLOGY CO., LTD., SHANGHAI CITY, CHINA:
3,783,211, CANC. IIRN. RESTORED TO S.N. 77-415,664.
- SHANMAR, INC., HOUSTON, TX:
2,740,441, CANC. INT. CL. 9.
- SHAPELL MORTGAGE, INC., BEVERLY HILLS, CA:
4,016,422, MULTIPLE CLASS, INT. CLS. 35, 36 AND 45.
- SHARED MEDIA LICENSING, INC., SEATTLE, WA:
2,910,637, CANC. INT. CL. 35.

SHARK EATING DOG, LLC, LOS ANGELES, CA, DBA VINTAGE TROUBLE:
4,015,767, PUB. 6-7-2011. INT. CL. 25.

SHARK EYES, INC., LOS ANGELES, CA:
4,015,600, PUB. 6-7-2011. INT. CL. 9.
4,015,603, PUB. 6-7-2011. INT. CL. 9.
4,015,608, PUB. 6-7-2011. INT. CL. 9.

SHARK TANK MEDIA LLC, FORT LAUDERDALE, FL:
4,015,254, PUB. 6-7-2011. INT. CL. 41.

SHARPRO GRIP, WEST COVINA, CA:
2,910,963, CANC. INT. CL. 28.

SHAW INDUSTRIES GROUP, INC., DALTON, GA:
2,909,643, CANC. INT. CL. 23.

SHAW, CLYDE THOMAS, WINCHESTER, VA:
2,421,169. REN. 7-15-11. INT. CL. 41.

SHEARN, MICHAEL JR., AUSTIN, TX:
2,516,875. REN. 7-18-11. INT. CL. 36.

SHEETZ OF DELAWARE, INC., WILMINGTON, DE:
2,492,351. REN. 7-18-11. INT. CL. 32.

SHEN, JIN WEN, SHORT HILLS, NJ:
4,016,926, INT. CL. 35.

SHENZHEN DONGYANGGUANG INDUSTRIAL DEVELOPMENT CO., LTD., NANSHAN DISTRICT, SHENZHEN, GUANGDONG, CHINA:
2,574,059. REN. 7-18-11. INT. CL. 9.

SHENZHEN SEETHRU TELECOMMUNICATION COMPANY LTD., SHENZHEN, CHINA:
4,014,502, PUB. 6-7-2011. INT. CL. 9.

SHERIDAN HEALTHCARE, INC., SUNRISE, FL:
4,015,454, PUB. 6-7-2011. INT. CL. 42.

SHERMAN, ELEANOR, LARCHMONT, NY, DBA TECHNO-WIPE:
1,694,342. REN. 7-15-11. INT. CL. 16.

SHIMANO INC., SAKAI CITY, OSAKA 590-8577, JAPAN:
1,682,115. REN. 7-15-11. INT. CL. 28.

SHIMANO INC., SAKAI, OSAKA, JAPAN, SHIMANO INDUSTRIAL COMPANY LIMITED, SAKAI, OSAKA, JAPAN:
1,693,226. REN. 7-15-11. INT. CL. 28.

SHIMOZAWA, SHIGEO, YOKOHAMA-SHI, KANAGAWA-KEN, JAPAN:
2,911,611, CANC. MULTIPLE CLASS, INT. CLS. 25 AND 28.

SHINWA GRILLS, LLC, FRANKLIN PARK, IL:
4,016,880, INT. CL. 11.
4,016,881, INT. CL. 11.

SHIPMAN, MARISSA J, SAN FRANCISCO, CA:
4,016,352, INT. CL. 3.

SHISEIDO COMPANY, LTD., CHUO-KU, TOKYO, JAPAN:
2,473,850. REN. 7-15-11. INT. CL. 21.

SHM HOLDINGS, LTD., TORTOLA, BR. VIRGIN ISLANDS:
4,014,677, PUB. 6-7-2011. MULTIPLE CLASS, INT. CLS. 9, 35 AND 41.

SHOOFLY DESIGN, INC., JOHNSTOWN, CO:
2,909,428, CANC. INT. CL. 25.

SHOOT THE FREAK, INC., BROOKLYN, NY:
2,910,079, CANC. INT. CL. 41.

SHPUR, MAURICE, TORONTO, ONTARIO, CANADA:
4,014,246, PUB. 6-7-2011. INT. CL. 44.

SHTOKMAN DEVELOPMENT AG, SWITZERLAND:
4,014,486, PUB. 6-7-2011. MULTIPLE CLASS, INT. CLS. 4, 7, 9, 12, 35, 37, 39 AND 42.

SHUFFLE MASTER, INC., LAS VEGAS, NV:
2,910,650, CANC. INT. CL. 28.
2,910,651, CANC. INT. CL. 28.
2,910,794, CANC. INT. CL. 41.

SHUSTA, PERRY, ANTIOCH, CA:
4,015,847, PUB. 6-7-2011. INT. CL. 25.

SIDEPIN LIMITED, TAIPEI, TAIWAN:
4,016,878, INT. CL. 20.

SIEGEL OIL COMPANY, DENVER, CO:
4,016,248, MULTIPLE CLASS, INT. CLS. 1 AND 4.

SIEMENS AKTIENGESELLSCHAFT, MUNICH, FED REP GERMANY:
2,910,461, CANC. INT. CL. 9.

SIEMENS AKTIENGESELLSCHAFT, FED REP GERMANY:
4,014,506, PUB. 6-7-2011. MULTIPLE CLASS, INT. CLS. 1, 7, 9, 10, 11, 12, 16, 35, 36, 38, 41 AND 42.
4,014,585, PUB. 6-7-2011. INT. CL. 41.

SIEMENS BUILDING TECHNOLOGIES AG, 8008 ZURICH, SWITZERLAND:
2,910,752, CANC. INT. CL. 9.

SIEMENS IT SOLUTIONS AND SERVICES GMBH, FED REP GERMANY:
4,014,530, PUB. 6-7-2011. MULTIPLE CLASS, INT. CLS. 9, 35, 42 AND 45.

SIERRA HEALTHSTYLES LLC, TUCSON, AZ:
4,016,186, MULTIPLE CLASS, INT. CLS. 35, 36 AND 37.
4,016,604, INT. CL. 35.
4,016,605, INT. CL. 35.

SIFTEO, INC., SAN FRANCISCO, CA:
4,016,490, MULTIPLE CLASS, INT. CLS. 9 AND 28.

SIGHTLINES, LLC, GUILFORD, CT:
2,459,794. REN. 7-19-11. INT. CL. 36.

SIGMA-ALDRICH BIOTECHNOLOGY L.P., ST. LOUIS, MO:
2,458,017. REN. 7-16-11. INT. CL. 1.

SIGNAL STUDIOS, LLC, BOTHELL, WA:
4,014,326, PUB. 6-7-2011. INT. CL. 9.

SIGNET INTERNATIONAL LICENSING INC., PICKERING, ONTARIO, CANADA:
2,476,906. REN. 7-19-11. INT. CL. 8.

SILDREY, LLC, DOTHAN, AL:
4,016,852, INT. CL. 41.

SILEX MICROSYSTEMS AB, JÄRFÄLLA, SWEDEN:
4,016,475, MULTIPLE CLASS, INT. CLS. 40 AND 42.

SILICON BEACH SYSTEMS, INC., PALM COAST, FL:
2,910,264, CANC. INT. CL. 9.

SILICON SEMICONDUCTOR CORPORATION, RESEARCH TRIANGLE PARK, NC:
2,911,132, CANC. INT. CL. 9.

SILICON VALLEY TECHNOLOGY LIQUIDATORS, INC., CAMPBELL, CA:
2,909,745, CANC. MULTIPLE CLASS, INT. CLS. 35, 36 AND 40.

SILLS, JERRY, VIRGINIA BEACH, VA:
4,017,427, INT. CL. 35.

SILS CONSTRUCTION, INC., LEXINGTON, VA:
2,911,486, CANC. INT. CL. 10.

SILVER LAKE MANAGEMENT, L.L.C., MENLO PARK, CA:
2,466,274. REN. 7-16-11. INT. CL. 36.
2,466,275. REN. 7-16-11. INT. CL. 36.

SILVER, ALAN H., CORAL SPRINGS, FL:
2,911,342, CANC. INT. CL. 10.

SIMON, MAUREEN J., MILL VALLEY, CA:
4,014,309, PUB. 6-7-2011. INT. CL. 45.

SIMONIZ USA, INC., BOLTON, CT:
4,014,801, PUB. 6-7-2011. INT. CL. 3.

SIMONSEN, MARK S., PROVO, UT:
2,411,871, CANC. INT. CL. 9.

SIMONSON, JACK, VILLA PARK, IL:
4,016,407, INT. CL. 37.

SIMPLEHUMAN, LLC, LOS ANGELES, CA:
2,910,224, CANC. INT. CL. 21.

SIMPLICITY ALLIANCE, INC., WESTLAKE, OH, SIMPLICITY PAYMENT ASSOCIATION, INC., WESTLAKE, OH:
1,651,009. REN. 7-20-11. INT. CL. 36.

SIMPLY GREEN SOLUTIONS INC, ALHAMBRA, CA:
4,015,668, PUB. 6-7-2011. INT. CL. 18.

SIMPSON STRONG-TIE COMPANY, INC., PLEASANTON, CA:
2,490,622. REN. 7-16-11. INT. CL. 19.

SIMPSON, STEVEN W., PORT TOWNSEND, WA:
2,413,229, CANC. INT. CL. 42.

SIMULATION CURRICULUM CORP., EDINA, MN:
2,910,535, CANC. INT. CL. 9.

SINCLAIR BROADCAST GROUP, INC., COCKEYSVILLE, MD:
4,014,952, PUB. 6-7-2011. INT. CL. 38.

SINDACO, ALFRED RONALD, MALVERN, PA, DBA JUST BEND AND SINDACO, MARGARET M, MALVERN, PA, DBA JUST BEND:
4,016,559, INT. CL. 25.

SINGLE SOURCE ROOFING CORPORATION, MCKEES ROCKS, PA:
2,540,656. REN. 7-18-11. MULTIPLE CLASS, INT. CLS. 19,

- 37 AND 42.
 SINMAG EQUIPMENT CORPORATION, DAAN DIST., TAIPEI, TAIWAN:
 4,014,237, PUB. 6-7-2011. INT. CL. 11.
 SINNS OF ATTRACTION, LLC, CLAREMONT, CA:
 4,015,938, PUB. 6-7-2011. INT. CL. 41.
 SIR ROCCO FORTE LIMITED, LONDON SW1Y 4QU, ENGLAND:
 2,911,672, CANC. MULTIPLE CLASS, INT. CLS. 36, 39, 41 AND 43.
 SITESALIVE FOUNDATION, INC., MARBLEHEAD, MA:
 2,477,160, REN. 7-19-11. INT. CL. 41.
 SIX PONY HITCH, LLC, MISSOULA, MT:
 4,014,795, PUB. 6-7-2011. INT. CL. 42.
 4,014,797, PUB. 6-7-2011. INT. CL. 42.
 SI03, INC., CAPE GIRARDEAU, MO:
 4,017,148, INT. CL. 5.
 SKA GLOBAL OY, HELSINKI, FINLAND:
 2,910,399, CANC. MULTIPLE CLASS, INT. CLS. 16, 35 AND 41.
 SKECHERS U.S.A., INC. II, MANHATTAN BEACH, CA:
 4,016,562, INT. CL. 14.
 SKEIE AS, N-4301 SANDNES, NORWAY:
 4,014,567, PUB. 6-7-2011. INT. CL. 20.
 SKIDDERS FOOTWEAR INC., NEW YORK, NY:
 4,016,695, INT. CL. 25.
 SKIDMORE COLLEGE, SARATOGA SPRINGS, NY:
 2,911,782, CANC. INT. CL. 41.
 2,911,783, CANC. INT. CL. 16.
 SKIN HOLEZ, COPPERPOLIS, CA:
 4,017,326, INT. CL. 35.
 SKINLUMA, LLC, STONY CREEK, CT:
 4,015,884, PUB. 6-7-2011. MULTIPLE CLASS, INT. CLS. 3 AND 5.
 4,015,885, PUB. 6-7-2011. MULTIPLE CLASS, INT. CLS. 3 AND 5.
 4,015,887, PUB. 6-7-2011. MULTIPLE CLASS, INT. CLS. 3 AND 5.
 SKINSFOUNDRY INC, SHELBY TWP, MI:
 2,910,809, CANC. INT. CL. 16.
 SKY PERFECT JSAT CORPORATION, TOKYO, JAPAN:
 4,015,215, PUB. 6-7-2011. INT. CL. 38.
 SKYDIVE KY LLC, GREENSBURG, KY:
 4,015,146, PUB. 6-7-2011. INT. CL. 41.
 SKYWORKS INTERACTIVE, INC., HACKENSACK, NJ:
 2,910,026, CANC. INT. CL. 9.
 SLEEP INNOVATIONS INC., WEST LONG BRANCH, NJ:
 2,471,859, REN. 7-16-11. MULTIPLE CLASS, INT. CLS. 20 AND 24.
 SM TM LLC, SCARSDALE, NY:
 4,014,765, PUB. 6-7-2011. INT. CL. 43.
 SMA INFORMATICS PARTNERS LLC, RICHMOND, VA, DBA SURGICAL OUTCOMES INFORMATION EXCHANGE:
 4,015,177, PUB. 6-7-2011. INT. CL. 35.
 SMAC, INC., CITY OF INDUSTRY, CA:
 4,016,244, INT. CL. 25.
 SMALL BUSINESS FINANCIAL EXCHANGE, INC., WHEATON, IL:
 4,015,970, PUB. 6-7-2011. INT. CL. 36.
 SMALL BUSINESS TRENDS LLC, MEDINA, OH:
 4,015,277, PUB. 6-7-2011. MULTIPLE CLASS, INT. CLS. 35 AND 41.
 SMALLCAP WORLD FUND, INC., LOS ANGELES, CA:
 1,674,489, REN. 7-16-11. INT. CL. 36.
 SMALLEY, JEFF, NORTH HAVEN, CT:
 4,017,074, MULTIPLE CLASS, INT. CLS. 30 AND 33.
 SMART MEDIA, LLC, LAMBERTVILLE, NJ:
 4,015,705, PUB. 6-7-2011. INT. CL. 35.
 SMART PARTS, INC., LOYALHANNA, PA:
 2,412,574, CANC. INT. CL. 28.
 2,911,381, CANC. INT. CL. 28.
 SMARTLINK RADIO NETWORKS INC., WALLINGFORD, CT:
 2,910,204, CANC. INT. CL. 9.
 SMARTPAK EQUINE, LLC, PLYMOUTH, MA:
 4,016,962, INT. CL. 5.
 SMARTY ANTS, INC., ROSS, CA:
 4,016,354, INT. CL. 28.
 SMARTYSHORTZ LLC, PAEONIAN SPRINGS, VA:
 4,014,673, PUB. 6-7-2011. INT. CL. 9.
 SMEV S.R.L., BASSANO DEL GRAPPA (VI), ITALY:
 2,909,599, CANC. MULTIPLE CLASS, INT. CLS. 11 AND 21.
 SMG BRANDS, INC., WILMINGTON, DE:
 2,457,069, REN. 7-16-11. INT. CL. 31.
 SMG-II, LLC, SAINT LOUIS, MO, DBA SUMMIT MARKETING:
 2,480,154, REN. 7-15-11. INT. CL. 36.
 SMIRNOV, IGOR V., SAN MARCOS, CA:
 2,911,716, CANC. INT. CL. 9.
 SMITH ABRASIVES, INC., HOT SPRINGS, AR:
 3,025,726, CANC. INT. CL. 9.
 SMITH ENTERPRISE, INC., TEMPE, AZ:
 4,014,818, PUB. 6-7-2011. INT. CL. 35.
 SMITH MOUNTAIN INDUSTRIES, INC., FOREST, VA:
 4,017,141, INT. CL. 4.
 SMITH, CHARLES, PALM COAST, FL:
 4,015,795, PUB. 6-7-2011. INT. CL. 30.
 SMITH, JOSEPH, STATEN ISLAND, NY:
 2,911,505, CANC. MULTIPLE CLASS, INT. CLS. 29 AND 30.
 SMITH, LAURA LEE, ROCHESTER, NY, DBA R.A.P. RULES (READING AND PREPARATION):
 2,909,744, CANC. INT. CL. 41.
 SMITHER FAMILY KITCHEN LLC, HOUSTON, TX:
 4,016,809, INT. CL. 30.
 SMITHKLINE BEECHAM (CORK) LIMITED, CARRIGLINE, IRELAND:
 2,911,671, CANC. INT. CL. 16.
 SMITHKLINE BEECHAM LIMITED, BRENTFORD, MIDDLESEX, UNITED KINGDOM:
 2,909,354, CANC. INT. CL. 5.
 SMITHS HEIMANN GMBH, WIESBADEN, FED REP GERMANY:
 4,016,197, MULTIPLE CLASS, INT. CLS. 7, 9 AND 20.
 SMITHS MEDICAL ASD, INC., KEENE, NH:
 2,480,301, REN. 7-16-11. INT. CL. 10.
 SMITHSON, FLOYD, CITRUS HEIGHTS, CA:
 2,910,341, CANC. INT. CL. 16.
 SMULSON, ANDREW NEAL, TARZANA, CA AND LOUDERMILK, BRENDAN COOPER, NORTH HOLLYWOOD, CA AND GIANCOLA, NICHOLAS JOHN, PACIFIC PALISADES, CA:
 4,015,394, PUB. 6-7-2011. INT. CL. 36.
 SNAP-ON BUSINESS SOLUTIONS INC., RICHFIELD, OH:
 4,015,061, PUB. 3-1-2011. INT. CL. 42.
 SNAPPLE BEVERAGE CORP, RYE BROOK, NY, UNADULTERATED FOOD PRODUCTS INC., BROOKLYN, NY:
 1,156,585, REN. 7-19-11. INT. CL. 32.
 SNELL & WILMER L.L.P., PHOENIX, AZ:
 2,911,656, CANC. INT. CL. 41.
 SNI SOLUTIONS, INC., GENESEO, IL:
 4,016,195, INT. CL. 1.
 SNYDER'S GATEWAY, INC., BREEZEWOOD, PA:
 2,468,929, REN. 7-19-11. INT. CL. 35.
 SOCIAL CONCEPTS, INC., REDWOOD CITY, CA:
 4,016,893, MULTIPLE CLASS, INT. CLS. 9, 41, 42 AND 45.
 4,017,032, MULTIPLE CLASS, INT. CLS. 9, 41 AND 42.
 SOCIAL SERVICE COORDINATORS, INC., MIAMI LAKES, FL:
 4,017,161, INT. CL. 35.
 SOCIEDAD DE COMERCIALIZACION INTERNACIONAL FLORES ACUARELA S.A., BOGOTA, COLOMBIA:
 2,910,518, CANC. INT. CL. 31.
 SOCIETE COOPERATIVE AGRICOLE LIMAGRAIN, 63720 CHAPPES, FRANCE, SOCIETE COOPERATIVE AGRICOLE DE SEMENCES DE LIMAGNE "LIMAGRAIN", CHAPPES, PUY-DE-DOME, FRANCE:
 1,647,578, REN. 7-20-11. INT. CL. 31.
 SOCIETE D'IMPORTATION DE DIFFUSION OU DISTRIBUTION D'ARTICLES DE SPORT S.I.D.A.S., VOIRON, FRANCE:
 4,015,346, PUB. 6-7-2011. MULTIPLE CLASS, INT. CLS. 7,

10 AND 25.
 SOCIETY FOR WORLDWIDE INTERBANK FINANCIAL TELECOMMUNICATION SCRL, B-1310 LA HULPE, BELGIUM:
 2,911,385, CANC. MULTIPLE CLASS, INT. CLS. 9, 16, 35, 36, 37, 38, 41 AND 42.
 SOCIETY OF CRITICAL CARE MEDICINE, MOUNT PROSPECT, IL:
 4,014,336, PUB. 6-7-2011. MULTIPLE CLASS, INT. CLS. 9, 16, 21, 25, 35, 38, 41 AND 44.
 4,014,337, PUB. 6-7-2011. MULTIPLE CLASS, INT. CLS. 6, 9, 16, 21, 25, 35, 41 AND 44.
 SODEXO, INC., GAITHERSBURG, MD:
 2,412,889, CANC. INT. CL. 42.
 SOFINA, PISCATAWAY, NJ:
 2,910,220, CANC. INT. CL. 20.
 SOFTPAC INDUSTRIES, INC., ELK RIVER, MN:
 2,911,365, CANC. INT. CL. 39.
 SOHO HOUSE LIMITED, LONDON, UNITED KINGDOM:
 4,016,723, MULTIPLE CLASS, INT. CLS. 41 AND 43.
 SOLAIR TECHNOLOGIES, INC., BLUFFTON, SC:
 4,015,577, PUB. 6-7-2011. INT. CL. 9.
 SOLDER-IT, INC., PLEASANTVILLE, NY:
 2,573,906, REN. 7-21-11. MULTIPLE CLASS, INT. CLS. 1 AND 8.
 SOLEMATES LLC, WASHINGTON, DC:
 4,016,622, INT. CL. 35.
 SOLO JAMAICA, LTD., MONTEGO BAY, ST. JAMES, JAMAICA W.I., JAMAICA:
 2,910,327, CANC. MULTIPLE CLASS, INT. CLS. 25 AND 35.
 SOMEDIA SOLUTIONS, INC., ROSWELL, GA:
 4,014,950, PUB. 6-7-2011. INT. CL. 35.
 SONCREW PRODUCTIONS, INC, BROOKLYN, NY, DBA SONIDO COSTENO:
 4,015,182, PUB. 6-7-2011. INT. CL. 41.
 SONGBIRD HEARING, INC., NORTH BRUNSWICK, NJ:
 2,460,177, REN. 7-21-11. INT. CL. 10.
 SONIA MILANO S.R.L., ITALY:
 3,896,646, CANC. MULTIPLE CLASS, INT. CLS. 3, 14 AND 25.
 SONIC BOOKS, INC., PALM HARBOR, FL:
 2,910,538, CANC. INT. CL. 9.
 SONIC INNOVATIONS, INC., SALT LAKE CITY, UT:
 4,016,902, INT. CL. 10.
 SONY ONLINE ENTERTAINMENT HOLDINGS INC., SAN DIEGO, CA:
 2,911,164, CANC. INT. CL. 9.
 SORSA HOLDINGS INC, BKLYN, NY:
 3,976,937, AM. INT. CL. 34.
 SOUND SLEEP PRODUCTS, INC., SUMNER, WA:
 4,016,825, INT. CL. 20.
 SOURCE INTERLINK MAGAZINES, LLC, NEW YORK, NY:
 2,910,218, CANC. INT. CL. 16.
 SOURCEFIRE, INC., COLUMBIA, MD:
 2,910,441, CANC. INT. CL. 9.
 4,017,243, INT. CL. 9.
 SOUTH BEACH BEVERAGE COMPANY, INC., NORWALK, CT:
 2,910,888, CANC. INT. CL. 32.
 2,910,889, CANC. INT. CL. 32.
 SOUTHEND INTERACTIVE AB, SE-211 42 MALMO, SWEDEN:
 2,911,621, CANC. INT. CL. 9.
 SOUTHERN MANAGEMENT CORPORATION, VIENNA, VA:
 2,909,804, CANC. INT. CL. 36.
 2,909,805, CANC. INT. CL. 36.
 SOUTHWEST GENERAL, MIDDLEBURG HEIGHTS, OH:
 4,015,301, PUB. 6-7-2011. INT. CL. 38.
 SOUTHWESTERN AHEC, INC., TRUMBULL, CT:
 4,015,218, PUB. 6-7-2011. MULTIPLE CLASS, INT. CLS. 35 AND 41.
 SOUTHWICK, MATHEW D., LEHI, UT:
 2,911,565, CANC. INT. CL. 28.
 SOVANNY'S SELECTIONS, INC., JAMESTOWN, NY, DBA EAST WEST NETWORK:
 2,911,566, CANC. INT. CL. 5.
 SPA DE SOLEIL, INC., SUN VALLEY, CA:
 4,015,123, PUB. 6-7-2011. INT. CL. 3.
 SPACESAVER CORPORATION, FORT ATKINSON, WI:
 4,016,977, INT. CL. 20.
 SPARKART LLC, OAKLAND, CA:
 2,910,529, CANC. MULTIPLE CLASS, INT. CLS. 35, 38 AND 41.
 SPARKLES! ENTERPRISES, LLC, FAIRFAX, VA:
 4,014,343, PUB. 6-7-2011. INT. CL. 43.
 SPARKSIGHT, INC., AUSTIN, TX:
 4,015,966, PUB. 6-7-2011. INT. CL. 35.
 SPAULDING DECON, LLC, TAMPA, FL:
 4,014,686, PUB. 6-7-2011. INT. CL. 40.
 SPECIAL GIFTS THEATRE, INC., NORTHBROOK, IL:
 2,910,033, CANC. INT. CL. 41.
 SPECIALIZED BICYCLE COMPONENTS, INC., MORGAN HILL, CA:
 4,016,069, PUB. 6-7-2011. INT. CL. 12.
 4,016,112, PUB. 6-7-2011. MULTIPLE CLASS, INT. CLS. 35 AND 36.
 4,016,727, INT. CL. 12.
 SPECIALTY PRODUCTS OF GREENWOOD, MISSOURI, INC., GREENWOOD, MO:
 4,017,060, INT. CL. 16.
 SPECIALTYCARE, INC., NASHVILLE, TN:
 4,016,564, INT. CL. 44.
 SPECTER OFF-ROAD, INC., CHATSWORTH, CA:
 2,575,620, REN. 7-15-11. INT. CL. 12.
 SPEED CHANNEL, INC., LOS ANGELES, CA:
 4,017,231, INT. CL. 41.
 4,017,246, INT. CL. 41.
 SPEEDO INTERNATIONAL LIMITED, LONDON N3 2QL, UNITED KINGDOM, SPEEDO KNITTING MILLS PTY. LIMITED, ARTARMON, NEAR SYDNEY, NEW SOUTH WALES, AUSTRALIA:
 718,276, REN. 7-16-11. U.S. CL. 39 (INT. CL. 25).
 SPEEDO INTERNATIONAL LIMITED, FINCHLEY, LONDON N3 2QL, UNITED KINGDOM, SPEEDO KNITTING MILLS PTY. LIMITED, ARTARMON, NEW SOUTH WALES, AUSTRALIA:
 1,161,031, REN. 7-16-11. INT. CL. 25.
 SPEEDWAY SUPERAMERICA LLC, ENON, OH:
 2,910,266, CANC. INT. CL. 35.
 SPELMAN COLLEGE, ATLANTA, GA:
 1,656,465, REN. 7-19-11. INT. CL. 41.
 SPENCER GIFTS LLC, EGG HARBOR TOWNSHIP, NJ:
 2,911,522, CANC. INT. CL. 11.
 2,911,523, CANC. INT. CL. 11.
 4,015,765, PUB. 6-7-2011. INT. CL. 25.
 SPENCER STEPHENS, LLC, PRESCOTT, AZ:
 4,016,009, PUB. 6-7-2011. INT. CL. 43.
 SPENCER'S INCORPORATED OF MOUNT AIRY, NC, MOUNT AIRY, NC:
 1,657,461, REN. 7-15-11. MULTIPLE CLASS, INT. CLS. 24 AND 25.
 SPERIAN EYE & FACE PROTECTION, INC., SMITHFIELD, RI:
 1,660,548, REN. 7-16-11. INT. CL. 9.
 SPIFFIT, INC., DENVER, CO:
 2,911,112, CANC. INT. CL. 35.
 SPILLMAN, SUSAN, WICHITA, KS:
 4,015,702, PUB. 6-7-2011. INT. CL. 41.
 SPIN MASTER LTD., TORONTO ONTARIO, CANADA:
 2,911,352, CANC. INT. CL. 9.
 SPIRES RESTAURANTS, INC., ORANGE, CA:
 2,910,238, CANC. INT. CL. 43.
 SPIRALINKS CORPORATION, LOS GATOS, CA:
 2,910,584, CANC. INT. CL. 9.
 SPIRIT OF AMERICA PRODUCTIONS, LLC, FRISCO, TX:
 4,017,143, INT. CL. 35.
 SPLASH PRODUCTS, INC., EAGAN, MN:
 2,470,177, REN. 7-15-11. INT. CL. 3.
 SPOKE MEDIA HOLDINGS, INC., SAN DIEGO, CA:
 4,016,433, MULTIPLE CLASS, INT. CLS. 9, 35 AND 42.
 SPOKES ETC., INC., VIENNA, VA:
 4,015,230, PUB. 6-7-2011. INT. CL. 35.

- SPONG, DOUGLAS BENSON, ISLE OF CAPRI, QUEENSLAND, AUSTRALIA:
2,910,700, CANC. MULTIPLE CLASS, INT. CLS. 9, 18 AND 25.
- SPONGEZZ INC., TORONTO, ONTARIO, CANADA:
4,017,064, INT. CL. 28.
- SPORTS ALLIANCE, INC., COLORADO SPRINGS, CO:
2,421,219, REN. 7-15-11, INT. CL. 42.
- SPORTS DESIGN AND DEVELOPMENT, INC., ALEXANDRIA, LA:
2,909,645, CANC. MULTIPLE CLASS, INT. CLS. 28 AND 35.
- SPORTSGRANTS, INC., HOOD RIVER, OR:
4,017,046, MULTIPLE CLASS, INT. CLS. 35 AND 36.
- SPORTSMEN OF NORTH AMERICA L.P., MESQUITE, TX:
4,017,314, INT. CL. 41.
- SPORTWALL INTERNATIONAL, INC., CARPINTERIA, CA:
2,910,354, CANC. INT. CL. 28.
- SPRI PRODUCTS, INC., LIBERTYVILLE, IL:
2,909,483, CANC. INT. CL. 28.
- SPRING AIR INTERNATIONAL LLC, CHELSEA, MA:
2,412,915, CANC. INT. CL. 20.
- SQUARE ENIX LIMITED, LONDON, UNITED KINGDOM:
2,910,267, CANC. MULTIPLE CLASS, INT. CLS. 9, 16, 28 AND 41.
- SR TELECOM INC., ST. LAURENT, CANADA:
2,910,704, CANC. INT. CL. 9.
- SRJ, INC., SCHAUMBURG, IL:
4,016,577, INT. CL. 12.
- SRS PHARMACEUTICALS PVT. LTD., MUMBAI, MAHARASHTRA, INDIA:
4,015,654, PUB. 6-7-2011, INT. CL. 5.
- ST CREATIONS, LLC, DES PLAINES, IL:
2,911,495, CANC. INT. CL. 21.
- ST LOUIS CARDINALS LP, ST LOUIS, MO:
1,161,375, REN. 7-15-11, INT. CL. 41.
- ST. ELMO, INCORPORATED, INDIANAPOLIS, IN:
2,412,985, CANC. INT. CL. 42.
2,412,988, CANC. INT. CL. 42.
2,413,028, CANC. INT. CL. 42.
- ST. JOHN CHURCH TRANSFORMATION MINISTRIES INTERNATIONAL, TACOMA, WA, DBA ST. JOHN BAPTIST CHURCH:
4,015,890, PUB. 6-7-2011, INT. CL. 45.
- ST. TROPEZ ACQUISITION CO. LIMITED, NOTTINGHAM, UNITED KINGDOM:
2,909,845, CANC. INT. CL. 3.
- STACKPOOLE, JAMES M., TAMPA, FL AND PROFUNDO, INC., TAMPA, FL:
2,015,371, CANC. MULTIPLE CLASS, INT. CLS. 35 AND 37.
- STADERINI, MARCO, 50063 FIGLINE VALDARNO, ITALY:
4,016,923, INT. CL. 25.
- STALEFISH LABS, LLC, NASHVILLE, TN:
2,910,391, CANC. INT. CL. 28.
- STALTARI, GWEN, ORLEANS, ON K1E 3W4, CANADA:
4,015,089, PUB. 6-7-2011, MULTIPLE CLASS, INT. CLS. 21 AND 25.
- STANDARD & POOR'S FINANCIAL SERVICES LLC, NEW YORK, NY:
4,015,605, PUB. 6-7-2011, INT. CL. 36.
- STANDARD FOODS CORPORATION, TAIPEI 106, TAIWAN:
4,016,270, INT. CL. 30.
- STANDARD MOTOR PRODUCTS, INC., LONG ISLAND CITY, NY:
2,459,442, REN. 7-18-11, INT. CL. 7.
- STANDARD SALES, INC., LOS ANGELES, CA:
4,015,964, PUB. 6-7-2011, INT. CL. 21.
- STANTON ADVANCED CERAMICS, INC., CLEVELAND, OH:
4,016,721, INT. CL. 19.
- STANWORTH DEVELOPMENT LIMITED, TORTOLA, BR. VIRGIN ISLANDS:
4,016,413, MULTIPLE CLASS, INT. CLS. 9 AND 41.
4,016,414, MULTIPLE CLASS, INT. CLS. 9 AND 41.
- STAPLES, INC., FRAMINGHAM, MA:
2,910,858, CANC. INT. CL. 35.
- STAR FRANCHISE SYSTEMS, INC., WINTER PARK, FL:
2,910,854, CANC. INT. CL. 43.
- STAR MANAGEMENT SERVICES, LLC, WEST BLOOMFIELD, MI:
2,911,728, CANC. MULTIPLE CLASS, INT. CLS. 10 AND 35.
- STAR PRODUCTS, S.A., SANTO DOMINGO, DOMINICAN REP:
2,909,569, CANC. INT. CL. 3.
- STAR SCIENTIFIC, INC., GLEN ALLEN, VA:
2,910,148, CANC. INT. CL. 34.
- STARBUCKS CORPORATION, SEATTLE, WA, DBA STARBUCKS COFFEE COMPANY:
4,017,035, INT. CL. 30.
4,017,041, INT. CL. 30.
- STARGAZER FOUNDATION, INC., FAIRFAX, VA:
2,910,474, CANC. MULTIPLE CLASS, INT. CLS. 38 AND 42.
2,910,475, CANC. MULTIPLE CLASS, INT. CLS. 38 AND 42.
- STARGRETTZ, INC., LOS ANGELES, CA:
4,016,750, MULTIPLE CLASS, INT. CLS. 9, 35 AND 41.
- STARMARK PET PRODUCTS, INC., HUTTO, TX:
4,017,238, INT. CL. 28.
- STARNET BUSINESS SOLUTIONS, INC., MAHWAH, NJ:
4,015,147, PUB. 6-7-2011, INT. CL. 40.
- START TODAY CO., LTD., CHIBA 261-7116, JAPAN:
4,014,602, PUB. 6-7-2011, INT. CL. 35.
- STATE FARM MUTUAL AUTOMOBILE INSURANCE COMPANY, BLOOMINGTON, IL:
4,015,445, PUB. 6-7-2011, INT. CL. 35.
- STATION CASINOS, INC., LAS VEGAS, NV:
3,862,053, COR. INT. CL. 43.
- STAYWELL ENTERPRISES, LLC, BETHESDA, MD:
2,910,192, CANC. INT. CL. 43.
- STEAG AKTIENGESELLSCHAFT, 45128 ESSEN, FED REP GERMANY:
2,910,247, CANC. MULTIPLE CLASS, INT. CLS. 35, 36, 37, 38, 39, 40, 41, 42 AND 45.
- STEAK N SHAKE, LLC, INDIANAPOLIS, IN:
4,017,371, INT. CL. 30.
- STEARNS PRODUCT DEVELOPMENT, INC., PERRIS, CA:
1,632,162, REN. 7-16-11, INT. CL. 7.
- STEELCASE INC., GRAND RAPIDS, MI:
4,014,245, PUB. 6-7-2011, MULTIPLE CLASS, INT. CLS. 9 AND 20.
- STEELE, CAROL, C., FRONT ROYAL, VA:
2,909,443, CANC. INT. CL. 21.
- STEIN MART HOLDING CORP., JACKSONVILLE, FL:
4,017,090, INT. CL. 35.
- STEINWAY, INC., LONG ISLAND CITY, NY:
4,015,223, PUB. 6-7-2011, INT. CL. 9.
- STENZLER, BRIAN A., LAKE GROVE, NY AND BARON, GREGG M., LAKE GROVE, NY:
2,910,497, CANC. INT. CL. 44.
- STEPHANY & COMPANY, LLC, WASHINGTON, DC:
4,016,024, PUB. 6-7-2011, INT. CL. 45.
- STEPHEN A. HALES, PROVO, UT:
4,015,559, PUB. 6-7-2011, INT. CL. 42.
- STEPHEN SHAPIRO ENTERPRISES, LLC, QUINCY, MA:
4,016,691, INT. CL. 9.
- STEPHENS, LEMEUL C., ELGIN, SC:
2,412,551, CANC. INT. CL. 30.
- STEWART COLLECTION, INC., THE, CHICAGO, IL, DBA SCI MARKETING, INC., FRASER, REGINA S., LAKE ZURICH, IL, DBA THE STEWART COLLECTION AND DBA STEWART COLLECTION PRODUCTIONS:
1,689,378, REN. 7-16-11, INT. CL. 41.
- STICHT, WALTER, 4800 ATTNANG-PUCHHEIM, AUSTRIA:
2,909,472, CANC. MULTIPLE CLASS, INT. CLS. 7 AND 9.
- STINGER INDUSTRIES, LLC, MURFREESBORO, TN:
2,483,097, REN. 7-20-11, INT. CL. 20.
- STOKELY-VAN CAMP, INC., CHICAGO, IL:
4,017,192, INT. CL. 32.
- STONES INC., TALLAHASSEE, FL:
4,016,306, INT. CL. 34.

- STOP SHOT INTERNATIONAL PTY LTD, LINDFIELD NSW, AUSTRALIA:
2,910,522, CANC. INT. CL. 19.
- STORE-SCAN, LLC, PHONEIX, AZ:
2,575,860, CANC. INT. CL. 9.
- STORSACK TRADCO LIMITED, GOOLE, EAST YORKSHIRE, DN14 6UE, UNITED KINGDOM:
2,909,359, CANC. MULTIPLE CLASS, INT. CLS. 20 AND 22.
2,909,360, CANC. MULTIPLE CLASS, INT. CLS. 20 AND 22.
- STOXX LIMITED, 8001 ZURICH, SWITZERLAND:
2,460,544, REN. 7-21-11. MULTIPLE CLASS, INT. CLS. 16, 35, 36, 38, 41 AND 42.
- STRAIGHT BUILDERS, INC., KANSAS CITY, MO:
2,910,003, CANC. INT. CL. 37.
- STRANCO INC, MICHIGAN CITY, IN:
2,911,759, CANC. INT. CL. 6.
- STRANGE MUSIC, INC., BLUE SPRINGS, MO:
4,016,487, INT. CL. 14.
- STRANISE LLC, NORTHAMPTON, MA, DBA LAZER SAUCE:
4,015,400, PUB. 6-7-2011. INT. CL. 30.
- STRATEGIC HEALTHCARE GROUP, LLC, INDIANAPOLIS, IN:
4,015,453, PUB. 6-7-2011. INT. CL. 44.
- STRATEGY BIT CONSULTING LLC, SEATTLE, WA:
4,015,392, PUB. 6-7-2011. INT. CL. 35.
- STRAWHUN, KELLI, CARLSBAD, CA, CA AND STRAWHUN, DENNIS, CARLSBAD, CA, CA:
4,016,945, INT. CL. 25.
- STREET LAW, INC., SILVER SPRING, MD:
3,809,992, COR. MULTIPLE CLASS, INT. CLS. 16 AND 41.
- STRENGTH OF NATURE, LLC, SAVANNAH, GA:
4,015,741, PUB. 6-7-2011. INT. CL. 3.
4,015,742, PUB. 6-7-2011. INT. CL. 3.
- STROM, LEX, CASTLE ROCK, WA, DBA LEXCALIBURS:
4,016,849, MULTIPLE CLASS, INT. CLS. 6, 9, 16, 25 AND 41.
- STRONGTOOTH, INC., NEW YORK, NY:
2,910,714, CANC. MULTIPLE CLASS, INT. CLS. 41 AND 42.
- STRUCTURAL GRAPHICS, LLC, ESSEX, CT:
4,014,680, PUB. 6-7-2011. INT. CL. 35.
- STRUCTUS BUILDING TECHNOLOGIES INC, BEND, OR:
3,468,528, COR. INT. CL. 19.
- STRUCTUS BUILDING TECHNOLOGIES, INC., BEND, OR:
3,282,287, COR. INT. CL. 19.
3,370,780, COR. INT. CL. 19.
3,482,278, COR. INT. CL. 7.
- STUDENTCITY.COM, INC., PEABODY, MA:
2,440,739, REN. 7-19-11. INT. CL. 39.
- STUDIO IP HOLDINGS, LLC, WILMINGTON, DE:
4,015,973, PUB. 6-7-2011. INT. CL. 9.
- STUDIO5051, LLC, MINNEAPOLIS, MN, DBA STUDIO5051:
4,017,164, INT. CL. 19.
- STUDYBUDDYCAMPUS LLC, GOODYEAR, AZ:
4,014,853, PUB. 6-7-2011. INT. CL. 42.
- STUSSY, INC., IRVINE, CA:
2,509,305, REN. 7-16-11. INT. CL. 5.
- STYLE ASIA INC., MOONACHIE, NJ:
2,910,758, CANC. INT. CL. 8.
- STYLE.LICIOUS LLC, NEW YORK, NY:
4,015,541, PUB. 6-7-2011. INT. CL. 35.
- STYLEMARK, INC., ORMOND BEACH, FL:
4,014,828, PUB. 6-7-2011. INT. CL. 9.
- SUCCESSDNA LLC, STAMFORD, CT:
4,016,107, PUB. 6-7-2011. INT. CL. 35.
- SUCKERS FOOD PRODUCTS, L.L.C., BATON ROUGE, LA:
4,014,744, PUB. 6-7-2011. INT. CL. 43.
- SUCROGEN LIMITED, AUSTRALIA:
4,014,539, PUB. 6-7-2011. INT. CL. 30.
- SUGAR MEMORIES, L.L.C., BROOKLYN, OH:
2,471,039, REN. 7-21-11. INT. CL. 30.
- SUGHRUE, B. PATRICK, PORTLAND, OR:
2,909,351, CANC. INT. CL. 9.
- SUKANO FINANCE LTD, 8834 SCHINDELLEGI, SWITZERLAND:
2,910,734, CANC. MULTIPLE CLASS, INT. CLS. 1 AND 17.
- SULZER METCO MANAGEMENT AG, CH-8400 WINTERTHUR, SWITZERLAND:
1,152,886, REN. 7-19-11. INT. CL. 6.
1,153,421, REN. 7-19-11. INT. CL. 42.
- SUMCO CORPORATION, JAPAN:
3,606,197, COR. INT. CL. 9.
- SUMMER CLASSICS, INC., MONTEVALLO, AL:
4,016,541, INT. CL. 20.
- SUMMER INFANT (USA), INC., WOONSOCKET, RI:
4,016,952, INT. CL. 12.
4,016,954, INT. CL. 21.
4,016,955, INT. CL. 9.
4,016,958, INT. CL. 9.
- SUMMIT ENTERTAINMENT, LLC, SANTA MONICA, CA:
4,016,125, PUB. 6-7-2011. INT. CL. 5.
4,016,126, PUB. 6-7-2011. INT. CL. 30.
- SUMMITRUN COMMUNICATIONS, LLC, MAPLE VALLEY, WA, DBA CONVERGED GREEN:
4,015,585, PUB. 6-7-2011. INT. CL. 9.
- SUMNER GROUP, INC., ST. LOUIS, MO:
2,591,545, REN. 7-18-11. INT. CL. 35.
- SUN CHEMICAL CORPORATION, PARSIPPANY, NJ:
1,669,986, REN. 7-16-11. INT. CL. 2.
- SUN LIFE ASSURANCE COMPANY OF CANADA, TORONTO, ONTARIO, CANADA:
4,016,346, INT. CL. 35.
- SUN LIFE ASSURANCE COMPANY OF CANADA (U.S.), WELLESLEY HILLS, MA AND SUN LIFE ASSURANCE COMPANY OF CANADA, TORONTO, CANADA:
2,491,099, REN. 7-18-11. INT. CL. 36.
- SUN WHOLESALE SUPPLY, INC., CLEARWATER, FL:
1,685,449, REN. 7-19-11. INT. CL. 28.
- SUNBELT RENTALS, INC., FORT MILL, SC, NATIONSR-ENT WEST, INC., SACRAMENTO, CA:
2,407,059, REN. 7-19-11. MULTIPLE CLASS, INT. CLS. 35 AND 37.
- SUNDECK PRODUCTS USA, INC., ARLINGTON, TX:
2,461,427, REN. 7-18-11. MULTIPLE CLASS, INT. CLS. 19 AND 40.
- SUNDOG INTERACTIVE, INC., FARGO, ND:
4,014,302, PUB. 10-26-2010. INT. CL. 35.
- SUNNYSIDE GROUP LLC, WASHINGTON, DC:
4,015,852, PUB. 6-7-2011. INT. CL. 43.
- SUNRIDGE NURSERIES, INC., BAKERSFIELD, CA:
2,501,345, REN. 7-16-11. INT. CL. 1.
- SUNSET FOOD MART, INC., HIGHLAND PARK, IL, DBA SUNSET FOODS:
4,014,780, PUB. 6-7-2011. INT. CL. 35.
- SUNSTONE VINEYARDS & WINERY, INC., SANTA YNEZ, CA:
2,910,510, CANC. MULTIPLE CLASS, INT. CLS. 31 AND 33.
- SUPERIOR CONTRACT CLEANERS, INC., WEST BERLIN, NJ:
4,015,217, PUB. 6-7-2011. INT. CL. 37.
- SUPERIOR GENERAL PARTNER INC., CALGARY, ALBERTA, CANADA:
4,014,400, PUB. 6-7-2011. MULTIPLE CLASS, INT. CLS. 35, 36 AND 39.
- SUPERMEDIA LLC, DFW AIRPORT, TX:
4,016,089, PUB. 6-7-2011. INT. CL. 42.
- SUPERNOVA DIAGNOSTICS, INC, DAMMASCUS, MD:
4,016,784, MULTIPLE CLASS, INT. CLS. 9 AND 10.
- SUPERSHEAR INC, MESA, AZ:
4,015,216, PUB. 6-7-2011. INT. CL. 7.
- SUPERSHUTTLE INTERNATIONAL, INC., SCOTTSDALE, AZ:
4,016,738, INT. CL. 39.
- SUPPLEMENT FIRST, RANDOLPH, NJ, DBA SUPPLEMENT FIRST:
4,015,771, PUB. 6-7-2011. INT. CL. 5.
- SUPPORT.COM, INC., REDWOOD CITY, CA:
4,015,318, PUB. 6-7-2011. INT. CL. 42.

- SUPRESOFT INC., HUBEI 430074, CHINA:
2,412,135, CANC. INT. CL. 9.
- SURADO SOLUTIONS, INC., RIVERSIDE, CA:
2,412,491, CANC. INT. CL. 9.
- SURE! LLC, SCOTTSDALE, AZ:
4,016,007, PUB. 6-7-2011. INT. CL. 28.
- SUREFED, LTD., KILLEEN, TX:
4,015,457, PUB. 6-7-2011. INT. CL. 5.
- SUREFIRE, LLC, FOUNTAIN VALLEY, CA:
4,017,094, INT. CL. 11.
- SURF SALT LLC, WILMINGTON, NC:
4,015,638, PUB. 6-7-2011. INT. CL. 30.
- SURGEON'S MANAGEMENT, INC., HOUSTON, TX:
4,016,247, INT. CL. 44.
- SURGERE, INC., NORTH CANTON, OH:
4,015,342, PUB. 6-7-2011. INT. CL. 35.
- SURVEY ANALYTICS, LLC, ISSAQUAH, WA:
4,015,718, PUB. 6-7-2011. INT. CL. 9.
4,015,722, PUB. 6-7-2011. INT. CL. 9.
- SURVIVOR PRODUCTIONS LLC, LOS ANGELES, CA:
4,015,330, PUB. 6-7-2011. INT. CL. 41.
- SUS, LLC, CASSELBERRY, FL:
4,015,712, PUB. 6-7-2011. INT. CL. 42.
- SUSAN LANDAU DESIGNS, LOS ANGELES, CA:
2,910,808, CANC. INT. CL. 35.
- SUSAN MUELLER SMITH, TRUSTEE FOR THE SUSAN MUELLER SMITH REVOCABLE TRUST DATED NOVEMBER 15, 2004, PLACIDA, FL:
2,911,738, CANC. INT. CL. 18.
- SUSAN SAYS, INC., ST. LOUIS, MO:
4,015,710, PUB. 6-7-2011. INT. CL. 41.
- SUTTER INSTRUMENT COMPANY, NOVATO, CA:
4,015,074, PUB. 6-7-2011. INT. CL. 9.
- SUYEN CORPORATION, PASAY CITY, 1300, PHILIPPINES:
4,017,038, MULTIPLE CLASS, INT. CLS. 3, 6, 16, 18, 20, 25, 26 AND 35.
- SWAG COMPANY, INC., SAN DIEGO, CA:
4,016,026, PUB. 6-7-2011. INT. CL. 28.
- SWAG4LIFE LLC, RALEIGH, NC:
4,015,994, PUB. 6-7-2011. INT. CL. 25.
- SWANNNDRI HOLDINGS LIMITED, CHRISTCHURCH, NEW ZEALAND:
2,410,519, CANC. INT. CL. 25.
- SWAROVSKI AKTIENGESELLSCHAFT, FL-9495 TRIESEN, LIECHTENSTEIN:
1,650,596, REN. 7-18-11. MULTIPLE CLASS, INT. CLS. 9, 11, 14, 18 AND 21.
1,650,596, CANC. MULTIPLE CLASS, INT. CLS. 8 AND 26.
- SWIATEK, JOYCE, CLIFTON, TN:
2,411,980, CANC. INT. CL. 29.
- SWICHAROOS INC, BIRMINGHAM, MI:
4,015,933, PUB. 6-7-2011. INT. CL. 25.
- SWIFT, TAYLOR, NASHVILLE, TN:
4,015,168, PUB. 6-7-2011. INT. CL. 9.
4,015,169, PUB. 6-7-2011. INT. CL. 18.
- SWIMC, INC., NEWARK, DE:
1,677,266, REN. 7-18-11. INT. CL. 2.
- SWISS ARMY BRAND LTD., MONROE, CT:
2,473,866, REN. 7-21-11. INT. CL. 25.
- SWISS SMILE COSMETICS AG, CH-6010 KRIENS, SWITZERLAND:
3,898,289 NEW CERT. 8-23-2011. MULTIPLE CLASS, INT. CLS. 3 AND 21.
- SYDNEY LAUREN TABAKIN MEMORIAL FUND INC., MEQUON, WI:
4,015,968, PUB. 6-7-2011. INT. CL. 36.
- SYLVESTER, R., TODD, SANDY, UT:
2,910,785, CANC. INT. CL. 41.
- SYNAPTYK, INC., PLANO, TX:
4,015,160, PUB. 6-7-2011. INT. CL. 42.
4,015,162, PUB. 6-7-2011. INT. CL. 42.
4,015,163, PUB. 6-7-2011. INT. CL. 42.
- SYNERGISTIC NETWORKS, INC., ELMHURST, IL:
2,909,653, CANC. INT. CL. 42.
- SYNGENTA PARTICIPATIONS AG, BASEL, SWITZERLAND:
2,911,730, CANC. INT. CL. 44.
4,016,298, INT. CL. 5.
- SYNIVERSE TECHNOLOGIES, INC., TAMPA, FL:
4,015,310, PUB. 6-7-2011. INT. CL. 38.
- SYNTELESYS EDUCATIONAL SERVICES, MONTEREY PARK, CA:
4,017,351, INT. CL. 41.
- SYRIS SCIENTIFIC, LLC, GRAY, ME:
2,470,189, REN. 7-18-11. INT. CL. 9.
- SYSCO CORPORATION, HOUSTON, TX:
4,016,813, INT. CL. 42.
- SYSTEMBAU HORST BABINSKY GMBH, FED REP GERMANY:
4,014,485, PUB. 6-7-2011. MULTIPLE CLASS, INT. CLS. 6, 19, 37 AND 42.
- SYSTEMFORWARD AMERICA, INC., LAFAYETTE, LA:
2,567,194, REN. 7-20-11. INT. CL. 42.
- S2 SECURITY CORP., FRAMINGHAM, MA:
4,015,471, PUB. 6-7-2011. INT. CL. 9.
4,015,472, PUB. 6-7-2011. INT. CL. 9.
4,015,473, PUB. 6-7-2011. INT. CL. 9.
4,015,474, PUB. 6-7-2011. INT. CL. 9.
- T. RICHARD TRAMMELL, GAFFNEY, SC:
4,016,823, INT. CL. 9.
- T-MOBILE USA, INC., BELLEVUE, WA:
4,017,360, INT. CL. 38.
- TA-XAN AG, 65185 WIESBADEN, FED REP GERMANY:
4,014,834, PUB. 6-7-2011. MULTIPLE CLASS, INT. CLS. 30 AND 32.
- TABIBZADEH, RAMIN, NEW YORK, NY:
4,015,739, PUB. 6-7-2011. INT. CL. 44.
- TACT MEDICAL STAFFING, NEW YORK, NY:
2,909,776, CANC. INT. CL. 35.
- TACTICIAN CORPORATION, ANDOVER, MA:
4,014,214, PUB. 6-7-2011. MULTIPLE CLASS, INT. CLS. 9 AND 35.
- TAGLE INFORMATION TECHNOLOGY INC., CALGARY, CANADA:
4,014,284, PUB. 6-7-2011. MULTIPLE CLASS, INT. CLS. 9 AND 42.
- TAILGATE CLOTHING CO., ANKENY, IA:
4,016,339, INT. CL. 25.
- TAIWAN EXTERNAL TRADE DEVELOPMENT COUNCIL, TAIPEI, TAIWAN:
4,016,158, MULTIPLE CLASS, INT. CLS. 35 AND 41.
4,016,160, INT. CL. 35.
- TAJ FEST, LLC, KITTERY, ME:
2,911,021, CANC. INT. CL. 41.
- TAJBAKHSH, FARIBORZ, OAK PARK, CA:
4,016,257, INT. CL. 9.
- TAKE IT OUTSIDE HOLDINGS INC., NORTH VANCOUVER, BC, CANADA:
4,014,403, PUB. 6-7-2011. MULTIPLE CLASS, INT. CLS. 16, 25, 41 AND 44.
- TAKE THE LEAD, WATERTOWN, NY:
2,910,477, CANC. INT. CL. 36.
- TAKE-TWO INTERACTIVE SOFTWARE, INC., NEW YORK, NY, TAKE-TWO INTERACTIVE SOFTWARE, INC., NEW YORK, NY:
2,476,204, REN. 7-15-11. INT. CL. 9.
- TALBOT, THOMAS, PLANTATION, FL:
4,014,859, PUB. 6-7-2011. INT. CL. 42.
- TALTECH LIMITED, TORTOLA, BR. VIRGIN ISLANDS:
2,421,220, REN. 7-15-11. INT. CL. 25.
- TAM HA PROJECT, LLC, SANTA MONICA, CA:
4,016,911, INT. CL. 41.
- TAN-EL-SYA CO., LTD., TOYAMA 936-0036, JAPAN:
4,017,033, INT. CL. 12.
- TANG, DAISY M., SAN JOSE, CA:
2,911,808, CANC. INT. CL. 3.
- TANGENT GROUP, PORTLAND, ME:
2,911,255, CANC. INT. CL. 5.
- TANGERINE CONFECTIONERY LIMITED, LIVERPOOL 7, UNITED KINGDOM, TAVENER RUTLEDGE LIMITED, LIVERPOOL 7, ENGLAND:
914,118, REN. 7-18-11. U.S. CL. 46 (INT. CL. 30).

TANGRAM INSURANCE SERVICES, INC., PETALUMA, CA:
2,909,945, CANC. INT. CL. 36.

TANJUNG CITECH UK LIMITED, PRIORY PARK WEST, HULL HU13 9PB, UNITED KINGDOM:
4,014,569, PUB. 6-7-2011. MULTIPLE CLASS, INT. CLS. 7 AND 11.

TANU U.S.A., INC., NEW YORK, NY:
4,017,348, INT. CL. 25.

TAP PUBLISHING COMPANY, CROSSVILLE, TN:
545,694, REN. 7-15-11. U.S. CL. 38 (INT. CL. 16).

TAPME, INC., CHICAGO, IL:
4,015,715, PUB. 6-7-2011. INT. CL. 9.
4,015,716, PUB. 6-7-2011. INT. CL. 42.

TAR-HONG MELAMINE USA, INC., CITY OF INDUSTRY, CA:
4,014,230, PUB. 6-7-2011. INT. CL. 21.

TARALDSSON, JOAKIM BO, STOCKHOLM, SWEDEN:
4,015,863, PUB. 6-7-2011. INT. CL. 44.

TARGET BRANDS, INC., MINNEAPOLIS, MN:
4,016,366, MULTIPLE CLASS, INT. CLS. 6, 20 AND 21.
4,016,681, MULTIPLE CLASS, INT. CLS. 6, 7, 9, 11, 14, 16, 18, 20, 21, 22, 24 AND 28.

TARRANT CAPITAL IP, LLC, FORT WORTH, TX:
2,434,782, REN. 7-19-11. INT. CL. 36.
2,434,782, CANC. INT. CL. 35.

TASTEFUL SELECTIONS, LLC, BANCROFT, WI:
4,014,835, PUB. 6-7-2011. INT. CL. 31.

TATE ACCESS FLOORS LEASING, INC., WILMINGTON, DE:
4,017,056, INT. CL. 6.
4,017,057, INT. CL. 6.

TATE INCORPORATED, ALEXANDRIA, VA:
4,016,289, MULTIPLE CLASS, INT. CLS. 9 AND 41.

TATE'S BAKE SHOP, INC., SOUTHAMPTON, NY:
4,015,517, PUB. 6-7-2011. INT. CL. 30.

TAVISTOCK RESTAURANTS, LLC, EMERYVILLE, CA, CONSTELLATION CONCEPTS, INC., CORTE MADERA, CA:
2,471,035, REN. 7-19-11. INT. CL. 42.

TAWA PLC, LONDON, UNITED KINGDOM:
4,016,316, INT. CL. 42.

TAX LADIES, INC., SHERWOOD, AR:
2,473,463, REN. 7-20-11. INT. CL. 35.

TAYLOR FRESH FOODS, INC., SALINAS, CA:
4,017,129, INT. CL. 29.

TAYMARK, INC., NORTH MANKATO, MN:
2,412,566, CANC. INT. CL. 42.

TBC TRADEMARKS, LLC, LAS VEGAS, NV:
4,016,373, INT. CL. 12.

TC LAND EXPRESSION, NANTES, FRANCE:
2,910,382, CANC. MULTIPLE CLASS, INT. CLS. 5 AND 42.

TEACHERS INSURANCE AND ANNUITY ASSOCIATION OF AMERICA, NEW YORK, NY:
4,014,930, PUB. 6-7-2011. INT. CL. 36.

TEACHERS' CURRICULUM INSTITUTE LLC, PALO ALTO, CA:
4,017,044, INT. CL. 41.

TEAM PLAY, INC., ELK GROVE VILLAGE, IL:
4,017,082, INT. CL. 9.

TEAM SUPREME, INC., ROCK FALLS, IL:
2,909,702, CANC. MULTIPLE CLASS, INT. CLS. 16, 28 AND 41.
2,909,703, CANC. INT. CL. 28.

TECH LOGIC CORPORATION, WHITE BEAR LAKE, MN:
4,016,862, INT. CL. 9.

TECHNIFEX PRODUCTS, LLC, VALENCIA, CA:
2,412,173, CANC. INT. CL. 7.

TECHNOLOGIES HOLDINGS CORP., HOUSTON, TX:
2,911,066, CANC. INT. CL. 5.

TECHNOLOGY STUDENT ASSOCIATION, INC., RESTON, VA:
2,411,720, CANC. INT. CL. 41.

TECNIMED SRL, ITALY:
4,014,540, PUB. 6-7-2011. INT. CL. 10.

TECSKOR CORPORATION, CALGARY, CANADA:
2,473,898, REN. 7-17-11. MULTIPLE CLASS, INT. CLS. 9, 35, 41 AND 42.

TEDDY ROTHSTEIN, BROOKLYN, NY, DBA DR. TED ROTHSTEIN DDS PHD:
4,015,256, PUB. 6-7-2011. INT. CL. 44.

TEKCETERA, INC., WOODLAND HILLS, CA:
2,910,928, CANC. INT. CL. 42.

TEKSYSTEMS, INC., COLUMBIA, MD:
2,910,099, CANC. INT. CL. 35.

TELENAV, INC., SUNNYVALE, CA:
4,014,764, PUB. 6-7-2011. MULTIPLE CLASS, INT. CLS. 9 AND 35.

TELEVISA, S.A. DE C.V., SANTA FE, MEXICO:
4,015,155, PUB. 6-7-2011. INT. CL. 41.

TEMPLE NUTRITION, LLC, MENLO PARK, CA:
2,911,306, CANC. INT. CL. 33.

TENCENT HOLDINGS LIMITED, GEORGE TOWN, GC, CAYMAN ISLANDS:
4,016,708, INT. CL. 41.

TENKARA USA, SAN FRANCISCO, CA:
4,015,586, PUB. 6-7-2011. INT. CL. 28.

TERRAPHASE ENGINEERING INC., OAKLAND, CA:
4,015,086, PUB. 6-7-2011. MULTIPLE CLASS, INT. CLS. 37, 40 AND 42.

TERRELL, IVANNA SAMAL, LEWISVILLE, TX:
4,016,779, INT. CL. 9.

TERRELL, IVANNA SAMAL, LEWISVILLE, TX, DBA LAS-TARIA:
4,016,898, INT. CL. 9.

TERRUS REAL ESTATE GROUP, L.L.C., DES MOINES, IA:
2,476,507, REN. 7-18-11. MULTIPLE CLASS, INT. CLS. 35, 36, 37 AND 42.

TERUMO KABUSHIKI KAISHA (TERUMO CORPORATION), TOKYO, JAPAN:
2,512,622, REN. 7-18-11. INT. CL. 10.

TESORO CORPORATION, SAN ANTONIO, TX:
2,470,027, REN. 7-16-11. INT. CL. 40.
2,473,954, REN. 7-16-11. INT. CL. 35.

TESTAMERICA LABORATORIES, INC., ASHEVILLE, NC:
2,909,617, CANC. INT. CL. 42.

TETRA HOLDING (US), INC., BLACKSBURG, VA:
2,478,933, REN. 7-15-11. INT. CL. 1.

TEXAS BIOMEDICAL RESEARCH INSTITUTE, SAN ANTONIO, TX:
4,017,049, MULTIPLE CLASS, INT. CLS. 35, 42, 43 AND 44.
4,017,050, MULTIPLE CLASS, INT. CLS. 35, 42, 43 AND 44.

TEXAS DAIRY QUEEN OPERATORS COUNCIL, BEDFORD, TX, TEXAS DAIRY QUEEN TRADE ASSOCIATION, FT. WORTH, TX:
1,158,563, REN. 7-21-11. INT. CL. 42.

TEXAS SCIENTIFIC PRODUCTS, FLOWER MOUND, TX:
4,016,524, INT. CL. 9.

TEXTRON INNOVATIONS INC., PROVIDENCE, RI:
1,659,447, REN. 7-18-11. INT. CL. 7.

TGI FRIDAY'S OF MINNESOTA, INC., CARROLLTON, TX:
4,014,726, PUB. 5-3-2011. INT. CL. 41.

THALES E-SECURITY LIMITED, ADDLESTONE, WEYBRIDGE, UNITED KINGDOM:
4,016,942, INT. CL. 9.

THAPA, PRABIN, KATHMANDU, NEPAL:
4,015,121, PUB. 6-7-2011. MULTIPLE CLASS, INT. CLS. 18, 20 AND 25.

THE AMERICAN ISRAEL PUBLIC AFFAIRS COMMITTEE, WASHINGTON, DC:
4,016,358, MULTIPLE CLASS, INT. CLS. 16, 35 AND 41.

THE AMERICAN OIL CHEMISTS' SOCIETY - ILLINOIS, URBANA, IL:
1,163,697, REN. 7-15-11. INT. CL. 16.

THE AMERICAN PARALEGAL INSTITUTE, INC., SUFFERN, NY:
4,017,408, INT. CL. 41.

THE AQUINO COMPANY, MIAMI, FL:
2,910,780, CANC. MULTIPLE CLASS, INT. CLS. 9 AND 41.

THE ARMANI SHOES CORPORATION, MIAMI, FL:
2,910,055, CANC. INT. CL. 25.

- THE AUGUSTANA COLLEGE ASSOCIATION, SIOUX FALLS, SD:
4,016,272, INT. CL. 25.
- THE BALLENGER GROUP, LLC, FREDERICK, MD:
2,910,743, CANC. INT. CL. 36.
- THE BANK OF NEW YORK, NEW YORK, NY:
2,909,596, CANC. INT. CL. 36.
- THE BANK OF NEW YORK MELLON, NEW YORK, NY:
1,647,779, REN. 7-18-11. INT. CL. 42.
- THE BAUE FUNERAL HOME CO., ST. CHARLES, MO:
4,016,969, INT. CL. 45.
4,016,970, INT. CL. 45.
- THE BEEF JERKY OUTLET FRANCHISE, INC., SEYMOUR, TN:
4,014,963, PUB. 6-7-2011. INT. CL. 35.
- THE BONE MARROW FOUNDATION, NEW YORK, NY:
4,015,279, PUB. 6-7-2011. INT. CL. 36.
- THE BOTTLE CREW, WEST BLOOMFIELD, MI:
2,911,264, CANC. INT. CL. 21.
- THE BRIDGE SCHOOL, HILLSBOROUGH, CA:
2,474,863, REN. 7-20-11. MULTIPLE CLASS, INT. CLS. 16 AND 41.
2,474,863, CANC. INT. CL. 25.
- THE BRITISH BROADCASTING CORPORATION, LONDON, UNITED KINGDOM:
2,909,384, CANC. MULTIPLE CLASS, INT. CLS. 9, 16, 25, 28 AND 41.
- THE BROADBAND GROUP, INC., LAS VEGAS, NV:
2,468,557, REN. 7-18-11. INT. CL. 42.
- THE BROADWAY LEAGUE INC., NEW YORK, NY:
2,911,583, CANC. INT. CL. 41.
- THE BUSH FOUNDATION, MINNEAPOLIS, MN:
4,017,100, INT. CL. 41.
- THE CABLE CENTER, DENVER, CO:
2,458,760, REN. 7-18-11. MULTIPLE CLASS, INT. CLS. 41 AND 42.
- THE CAMPAIGN FOR LIFE IN AMERICA, INC., LEWISBURG, PA:
2,462,594, REN. 7-18-11. INT. CL. 36.
- THE CARTOON NETWORK, INC., ATLANTA, GA:
4,016,253, INT. CL. 41.
- THE CENTER FOR FAITHWALK LEADERSHIP, AUGUSTA, GA:
2,911,107, CANC. INT. CL. 41.
- THE CHALLAH FAIRY INC., NEW CITY, NY:
4,015,312, PUB. 6-7-2011. MULTIPLE CLASS, INT. CLS. 30 AND 35.
- THE CHARTERED INSTITUTE OF MANAGEMENT ACCOUNTANTS, UNITED KINGDOM:
4,014,444, PUB. 3-23-2010. MULTIPLE CLASS, INT. CLS. 9, 16, 35 AND 41.
- THE CHICKASAW NATION, ADA, OK:
4,016,127, PUB. 6-7-2011. INT. CL. 41.
4,016,128, PUB. 6-7-2011. INT. CL. 41.
4,016,131, PUB. 6-7-2011. INT. CL. 41.
4,016,138, PUB. 6-7-2011. INT. CL. 43.
- THE CIARA GROUP, INC., LILBURN, GA:
2,909,884, CANC. INT. CL. 35.
2,909,971, CANC. INT. CL. 35.
- THE CLEVELAND CLINIC FOUNDATION, CLEVELAND, OH:
2,910,471, CANC. INT. CL. 44.
- THE CLOROX COMPANY, OAKLAND, CA:
2,531,814, REN. 7-15-11. INT. CL. 5.
- THE CLOSEOUT CONNECTION, INC., WARRENSVILLE HEIGHTS, OH, DBA: KEITH DANIELS, OTP SALES, AND ON TARGET PROMOTIONS:
2,910,815, CANC. INT. CL. 25.
- THE COCA-COLA COMPANY, ATLANTA, GA:
2,911,293, CANC. INT. CL. 32.
2,911,297, CANC. INT. CL. 32.
4,014,435, PUB. 4-15-2008. INT. CL. 32.
4,014,437, PUB. 5-20-2008. INT. CL. 32.
- THE COLONIAL WILLIAMSBURG FOUNDATION, WILLIAMSBURG, VA:
3,012,934, CANC. INT. CL. 8.
- THE COLORADO BAR ASSOCIATION, DENVER, CO:
4,016,767, U.S. CL. 200.
- THE COOPER INSTITUTE, DALLAS, TX:
4,014,242, PUB. 6-7-2011. INT. CL. 41.
- THE CORPORATE EXECUTIVE BOARD CO., ARLINGTON, VA:
4,014,786, PUB. 6-7-2011. INT. CL. 41.
- THE CROWN IN RIGHT OF THE COMMONWEALTH, AUSTRALIA:
4,014,509, PUB. 6-7-2011. MULTIPLE CLASS, INT. CLS. 9, 35, 42 AND 44.
- THE CULTURAL LANDSCAPE FOUNDATION, WASHINGTON, DC:
4,015,183, PUB. 6-7-2011. INT. CL. 44.
- THE CURATORS OF THE UNIVERSITY OF MISSOURI, COLUMBIA, MO:
4,015,655, PUB. 6-7-2011. MULTIPLE CLASS, INT. CLS. 25 AND 41.
4,015,656, PUB. 6-7-2011. MULTIPLE CLASS, INT. CLS. 25 AND 41.
- THE DAILY HOLDINGS, INC., WILMINGTON, DE:
4,017,358, INT. CL. 41.
- THE DAVEY TREE EXPERT COMPANY, KENT, OH:
4,015,744, PUB. 6-7-2011. INT. CL. 44.
- THE DENVER DUMB FRIENDS LEAGUE, DENVER, CO:
4,016,276, INT. CL. 44.
- THE DIABETES ASSOCIATION OF GREATER CLEVELAND, CLEVELAND, OH:
4,016,386, MULTIPLE CLASS, INT. CLS. 35, 36, 41 AND 44.
- THE DILLER CORPORATION, CINCINNATI, OH:
1,648,159, REN. 7-15-11. INT. CL. 17.
- THE EVERCARE COMPANY, ALPHARETTA, GA:
4,016,682, INT. CL. 21.
- THE FISH TALE ENTERPRISES, LLC, LOS ANGELES, CA:
1,159,562, REN. 7-16-11. INT. CL. 42.
- THE FJH MUSIC COMPANY INC., FT. LAUDERDALE, FL:
2,412,377, CANC. INT. CL. 16.
- THE FLADGATE PARTNERSHIP - VINHOS SA, VILA NOVA DE GALA, PORTUGAL:
4,014,691, PUB. 6-7-2011. INT. CL. 33.
- THE FLORIDA GOLF SCHOOL, INC., PORT ST. LUCIE, FL, DBA UNITED STATES GOLF TEACHERS FEDERATION:
4,015,202, PUB. 6-7-2011. MULTIPLE CLASS, INT. CLS. 35, 41 AND 42.
- THE FOUNDATION FOR THE ADVANCEMENT OF CARDIAC THERAPIES, WEST PALM BEACH, FL:
2,909,833, CANC. INT. CL. 41.
- THE GOODMAN GROUP, LLC, CHASKA, MN, DBA THE GOODMAN GROUP:
4,014,955, PUB. 6-7-2011. INT. CL. 35.
4,014,956, PUB. 6-7-2011. INT. CL. 35.
- THE GREAT POINT GROUP LLC, DARIEN, CT:
2,909,749, CANC. INT. CL. 35.
- THE HELPER COMPANY, TACOMA, WA:
2,910,056, CANC. INT. CL. 42.
- THE HOEFLER TYPE FOUNDRY, INC., NEW YORK, NY, DBA HOEFLER & FRERE-JONES:
4,014,426, PUB. 11-24-2009. MULTIPLE CLASS, INT. CLS. 9 AND 42.
4,015,982, PUB. 6-7-2011. INT. CL. 9.
4,016,045, PUB. 6-7-2011. INT. CL. 9.
4,016,049, PUB. 6-7-2011. INT. CL. 9.
4,016,051, PUB. 6-7-2011. INT. CL. 9.
- THE HOUSE DEVELOPMENT CORPORATION, NFP, CHICAGO, IL:
4,016,047, PUB. 6-7-2011. INT. CL. 41.
- THE HOWARD HUGHES CORPORATION, LAS VEGAS, NV:
2,909,701, CANC. INT. CL. 36.
- THE HOWLAND-HUGHES COMPANY, INC., WATERBURY, CT:
2,911,161, CANC. INT. CL. 35.
- THE IMAGE INITIATIVE, INC., SYRACUSE, NY:
4,014,724, PUB. 6-7-2011. INT. CL. 41.
- THE INDIAN HOTELS COMPANY LIMITED, MUMBAI - 400 001, INDIA:
4,016,147, INT. CL. 44.

THE INDIANA SOCIETY FOR THE PREVENTION OF CRUELTY TO ANIMALS, INDIANAPOLIS, IN, AKA ISPCA:
4,017,396, INT. CL. 41.
4,017,397, INT. CL. 25.

THE INLAND REAL ESTATE GROUP, INC., OAK BROOK, IL:
2,959,217, CANC. INT. CL. 37.

THE INTELLIGENT OFFICE SYSTEM, LLC, BOULDER, CO:
4,015,679, PUB. 6-7-2011. MULTIPLE CLASS, INT. CLS. 35 AND 36.
4,015,680, PUB. 6-7-2011. MULTIPLE CLASS, INT. CLS. 35 AND 36.

THE INTERNATIONAL CENTRE FOR MISSING AND EXPLOITED CHILDREN, ALEXANDRIA, VA, DBA INTERNATIONAL CENTRE FOR MISSING & EXPLOITED CHILDREN:
2,474,306, REN. 7-20-11. INT. CL. 42.

THE INTERNATIONAL SOCIETY OF DNA VACCINES, BLUE BELL, PA:
4,017,277, INT. CL. 41.

THE IRISH LION, INC., BLOOMINGTON, IN:
4,014,715, PUB. 6-7-2011. INT. CL. 29.

THE KARMA GROUP, GREEN BAY, WI:
2,909,729, CANC. INT. CL. 35.

THE KEY TV CORP., NEW YORK, NY:
4,016,514, MULTIPLE CLASS, INT. CLS. 35 AND 41.
4,016,515, MULTIPLE CLASS, INT. CLS. 35 AND 41.

THE LACLEDE GROUP, INC., ST. LOUIS, MO:
4,016,516, MULTIPLE CLASS, INT. CLS. 36 AND 39.
4,016,517, MULTIPLE CLASS, INT. CLS. 36 AND 39.

THE LED GUY FOR YOU, IRVINE, CA:
4,016,632, INT. CL. 11.

THE LEE COMPANY, WESTBROOK, CT:
4,015,661, PUB. 6-7-2011. INT. CL. 9.
4,015,688, PUB. 6-7-2011. INT. CL. 9.
4,015,749, PUB. 6-7-2011. INT. CL. 9.

THE LIFE IS GOOD COMPANY, BOSTON, MA:
2,911,483, CANC. INT. CL. 25.

THE LONG TERM CARE LADY, LLC, NAPLES, FL:
4,015,205, PUB. 6-7-2011. INT. CL. 36.

THE LUTHERAN CHURCH-MISSOURI SYNOD, KIRKWOOD, MO:
4,017,156, MULTIPLE CLASS, INT. CLS. 16 AND 41.

THE MARINE MAMMAL CENTER, SAUSALITO, CA:
4,016,250, INT. CL. 41.

THE MATTHEW SHEPARD FOUNDATION, DENVER, CO:
4,015,190, PUB. 6-7-2011. MULTIPLE CLASS, INT. CLS. 9, 16 AND 18.

THE MIDDLEBRIDGE EXCHANGE LLC, NEW YORK, NY:
2,910,174, CANC. INT. CL. 41.

THE MILESTONE GROUP, INC., DENVER, CO:
2,910,199, CANC. INT. CL. 36.

THE MILLS LIMITED PARTNERSHIP, CHEVY CHASE, MD:
2,911,574, CANC. MULTIPLE CLASS, INT. CLS. 36 AND 41.

THE NEST COLLECTIVE, INC., EMERYVILLE, CA:
4,017,220, INT. CL. 29.

THE NUTTY GOURMET, LLC, HUGHSON, CA:
4,015,621, PUB. 6-7-2011. MULTIPLE CLASS, INT. CLS. 29, 30 AND 35.

THE ORIGINAL BROOKLYN WATER BAGEL CO., INC., DELRAY BEACH, FL:
4,014,959, PUB. 6-7-2011. MULTIPLE CLASS, INT. CLS. 30, 32 AND 43.

THE OSS SOCIETY, INC., MCLEAN, VA:
4,017,369, INT. CL. 41.

THE PARENTING GROUP, INC., WINTER PARK, FL:
4,017,145, INT. CL. 35.

THE PET HYDRATION PEOPLE, LLC, CHICAGO, IL:
4,017,132, INT. CL. 31.

THE PET SAVERS FOUNDATION, INC., PORT WASHINGTON, NY:
4,016,500, MULTIPLE CLASS, INT. CLS. 25, 28, 35, 36, 41 AND 45.

THE PILOT SCHOOL, INC., WILMINGTON, DE:
4,015,286, PUB. 6-7-2011. MULTIPLE CLASS, INT. CLS. 41 AND 44.
4,015,287, PUB. 6-7-2011. MULTIPLE CLASS, INT. CLS. 41 AND 44.
4,015,288, PUB. 6-7-2011. MULTIPLE CLASS, INT. CLS. 41 AND 44.

THE PLACENCIA GROUP, LTD., BOCA RATON, FL:
4,016,003, PUB. 6-7-2011. MULTIPLE CLASS, INT. CLS. 36 AND 37.

THE PROCTER & GAMBLE COMPANY, CINCINNATI, OH:
4,016,628, MULTIPLE CLASS, INT. CLS. 3 AND 21.

THE PROVIDENT BANK, CINCINNATI, OH:
2,909,686, CANC. INT. CL. 42.

THE PRUDENTIAL INSURANCE COMPANY OF AMERICA, NEWARK, NJ:
4,016,612, MULTIPLE CLASS, INT. CLS. 36 AND 41.

THE QUADRANT CORPORATION, BELLEVUE, WA:
4,017,205, MULTIPLE CLASS, INT. CLS. 36 AND 37.

THE R.D. ROGERS COMPANY, SIOUX FALLS, SD:
4,015,185, PUB. 6-7-2011. MULTIPLE CLASS, INT. CLS. 35, 37 AND 42.

THE READER'S DIGEST ASSOCIATION, INC., WHITE PLAINS, NY:
4,016,350, MULTIPLE CLASS, INT. CLS. 9, 16 AND 41.

THE SAINT AUGUSTINE LIGHTHOUSE AND MUSEUM, INC., ST. AUGUSTINE, FL:
4,014,957, PUB. 6-7-2011. INT. CL. 35.
4,016,648, MULTIPLE CLASS, INT. CLS. 35 AND 41.

THE SALES PITCH, LLC, LIBERTYVILLE, IL:
4,015,367, PUB. 6-7-2011. MULTIPLE CLASS, INT. CLS. 35 AND 42.

THE SAN ANTONIO BOTANICAL CENTER SOCIETY, INC., SAN ANTONIO, TX:
2,911,620, CANC. INT. CL. 41.

THE SAUL ZAENTZ COMPANY DBA TOLKIEN ENTERPRISES, BERKELEY, CA:
4,016,191, INT. CL. 16.

THE SCOOP, INC., PRINCETON, NJ, TA PRINCETON SCOOP:
4,014,373, PUB. 6-7-2011. INT. CL. 35.

THE SERGIO CORPORATION, SOUTH BEND, IN, DBA FIRST RESPONSE DISASTER RESTORATION:
4,015,797, PUB. 6-7-2011. INT. CL. 40.

THE SHAPE OF LIES, NEW YORK, NY:
2,910,203, CANC. INT. CL. 14.

THE SMASHED CHEFS, CHESTERFIELD, MO:
2,909,883, CANC. INT. CL. 21.

THE SOCIETY OF HISPANIC PROFESSIONAL ENGINEERS, INC., LOS ANGELES, CA:
2,909,821, CANC. INT. CL. 41.

THE STARTUP STORE LLC, ATLANTA, GA:
4,017,155, MULTIPLE CLASS, INT. CLS. 35 AND 42.

THE SYNTEON GROUP, PORTER, TX:
4,016,382, INT. CL. 1.

THE THOUGHT EXCHANGE, LLC, MORRISTOWN, NJ:
4,016,668, INT. CL. 44.

THE THRASHERS, LLC, PACIFICA, CA:
4,016,033, PUB. 6-7-2011. INT. CL. 41.

THE TJX COMPANIES, INC., FRAMINGHAM, MA:
2,911,799, CANC. MULTIPLE CLASS, INT. CLS. 16 AND 20.

THE TORO COMPANY, BLOOMINGTON, MN:
4,016,235, INT. CL. 7.

THE TORONTO-DOMINION BANK, TORONTO, CANADA:
2,911,543, CANC. INT. CL. 41.

THE TRUST FOR THE AMERICAS, WASHINGTON D.C., DC:
4,015,219, PUB. 6-7-2011. MULTIPLE CLASS, INT. CLS. 35, 41 AND 42.

THE TRUST FOR THE AMERICAS, WASHINGTON, DC:
4,015,233, PUB. 6-7-2011. MULTIPLE CLASS, INT. CLS. 35, 41 AND 42.

THE TRUSTEES OF INDIANA UNIVERSITY, BLOOMINGTON, IN:
4,015,090, PUB. 6-7-2011. MULTIPLE CLASS, INT. CLS. 16 AND 41.

THE TRUSTEES OF THE SAN DIEGO FIREFIGHTERS BENEVOLENT FUND, SAN DIEGO, CA:
4,017,332, INT. CL. 36.

- THE UNITED STATES PLAYING CARD COMPANY, CINCINNATI, OH:
2,909,429, CANC. INT. CL. 28.
- THE UPPER DECK COMPANY, INC., CARLSBAD, CA:
2,413,052, CANC. INT. CL. 16.
- THE URBAN ALTERNATIVE, DALLAS, TX:
4,016,836, MULTIPLE CLASS, INT. CLS. 41 AND 45.
- THE VANDERBILT UNIVERSITY, NASHVILLE, TN:
4,016,209, INT. CL. 41.
- THE WASH GUYS CAR WASH, INC., SAN DIEGO, CA:
2,910,922, CANC. INT. CL. 37.
- THE WATER SYSTEM GROUP, INC., CAMARILLO, CA:
2,910,022, CANC. INT. CL. 11.
- THE WELLA CORP., WOODLAND HILLS, CA:
2,413,166, CANC. INT. CL. 3.
- THE WILDLIFE EXPERIENCE, INC., PARKER, CO:
2,911,600, CANC. INT. CL. 16.
- THE WINE GROUP LLC, TRACY, CA:
4,016,364, INT. CL. 33.
4,017,259, INT. CL. 33.
- THE WINGS FOUNDATION, DFW AIRPORT, TX:
2,909,910, CANC. INT. CL. 36.
- THE WITCH'S BREW LLC, PALM HARBOR, FL:
4,016,232, MULTIPLE CLASS, INT. CLS. 35 AND 43.
- THE WOLSTEIN GROUP, LLC, MORELAND HILLS, OH:
1,680,597, REN. 7-20-11, INT. CL. 37.
- THE WOODLANDS LAND DEVELOPMENT COMPANY, L.P., THE WOODLANDS, TX:
2,910,774, CANC. MULTIPLE CLASS, INT. CLS. 36, 37, 41 AND 43.
- THE WYNNE GUILD, INC., RICHMOND, VA:
2,909,493, CANC. MULTIPLE CLASS, INT. CLS. 35 AND 43.
2,909,495, CANC. MULTIPLE CLASS, INT. CLS. 35 AND 43.
- THEAS.COM, LLC, LEE'S SUMMIT, MO, DBA HANGITUP.COM:
4,017,026, INT. CL. 35.
4,017,027, INT. CL. 35.
- THEME MACHINES LLC, COLLEGE STATION, TX:
2,910,749, CANC. INT. CL. 9.
- THEODORE S. RAPPAPORT, AUSTIN, TX:
4,015,072, PUB. 6-7-2011, INT. CL. 42.
4,015,073, PUB. 6-7-2011, INT. CL. 42.
- THEOREM SOLUTIONS LIMITED, STAFFORDSHIRE, ENGLAND:
2,456,695, REN. 7-15-11, INT. CL. 9.
- THEOREM SOLUTIONS LIMITED, LICHFIELD, STAFFORDSHIRE, WS13 8RZ, ENGLAND:
2,459,041, REN. 7-15-11, INT. CL. 9.
- THERAVANCE, INC., SOUTH SAN FRANCISCO, CA:
4,015,826, PUB. 6-7-2011, INT. CL. 42.
- THERIGY, LLC, ORLANDO, FL:
4,015,188, PUB. 6-7-2011, MULTIPLE CLASS, INT. CLS. 35, 42 AND 44.
4,015,192, PUB. 6-7-2011, MULTIPLE CLASS, INT. CLS. 35, 42 AND 44.
- THERMALINK CORPORATION, DALLAS, TX:
2,910,189, CANC. INT. CL. 10.
- THERMIK GERÄTEBAU GMBH, FED REP GERMANY:
4,014,446, PUB. 6-7-2011, INT. CL. 9.
- THERMO ELECTRON LED GMBH, LANGENSELBOLD, FED REP GERMANY:
2,412,284, CANC. INT. CL. 11.
- THERMO STEAM SYSTEMS, INC., SOUTH BEND, IN:
2,469,850, REN. 7-15-11, INT. CL. 11.
- THERMOS L.L.C., ROLLING MEADOWS, IL:
2,911,684, CANC. INT. CL. 21.
- THETA TAU, AUSTIN, TX:
2,090,402, CANC. U.S. CL. 200.
- THETFORD CORPORATION, ANN ARBOR, MI:
4,015,936, PUB. 6-7-2011, INT. CL. 16.
- THIEN DUOC CO., LTD, TAN UYEN DISTRICT, BINH DUONG PROVINCE, VIETNAM:
4,016,303, INT. CL. 5.
- THINK ART LLC, ARABI, LA:
4,017,089, INT. CL. 16.
- THINKFUN INC., ALEXANDRIA, VA:
2,909,841, CANC. INT. CL. 28.
- THINKPETS, INC., EL SEGUNDO, CA, ZOASIS CORPORATION, SANTA MONICA, CA:
2,497,287, REN. 7-16-11, INT. CL. 16.
- THINWARE, INC., MCKINNEY, TX:
4,014,264, PUB. 6-7-2011, MULTIPLE CLASS, INT. CLS. 37 AND 42.
- THOIP, LONDON, UNITED KINGDOM:
4,014,253, PUB. 3-1-2011, MULTIPLE CLASS, INT. CLS. 9, 16, 25, 28 AND 41.
4,014,254, PUB. 3-1-2011, MULTIPLE CLASS, INT. CLS. 9, 16, 25, 28 AND 41.
- THOMAS C. FORD, AUSTIN, TX:
4,016,169, INT. CL. 25.
4,016,171, INT. CL. 18.
- THOMAS JEFFERSON FOUNDATION, INC., CHARLOTTESVILLE, VA:
2,517,606, REN. 7-16-11, INT. CL. 20.
- THOMAS M. O'RIORDAN, ORLANDO, FL:
4,015,981, PUB. 6-7-2011, INT. CL. 25.
4,015,992, PUB. 6-7-2011, INT. CL. 25.
- THOMAS PUBLISHING COMPANY, NEW YORK, NY:
4,016,863, MULTIPLE CLASS, INT. CLS. 35 AND 42.
- THOMPSON & MORGAN (GROUP) LTD, IPSWICH, UNITED KINGDOM:
2,514,158, REN. 7-16-11, INT. CL. 31.
- THOMPSON, CHARLES CHIC, KESWICK, VA, DBA CREATIVE MANAGEMENT GROUP:
2,479,498, REN. 7-15-11, INT. CL. 41.
- THOMPSON, CHRISTINE W, MERCER ISLAND, WA:
2,412,237, CANC. INT. CL. 35.
- THREE ONE ONE, RICHMOND, VA:
4,015,232, PUB. 6-7-2011, INT. CL. 41.
- THREEBYONE PTY LIMITED, FITZROY, MELBOURNE, AUSTRALIA:
4,015,077, PUB. 6-7-2011, INT. CL. 25.
- TICHENOR, BRUCE H., PLYMOUTH, CA, DBA STORY WINERY:
2,571,083, REN. 7-18-11, INT. CL. 16.
- TIFF'S TREATS HOLDINGS, INC., AUSTIN, TX:
4,014,442, PUB. 6-7-2011, MULTIPLE CLASS, INT. CLS. 30, 39 AND 43.
- TIGER TOOL INTERNATIONAL INCORPORATED, ABBOTSFORD, BRITISH COLUMBIA V2S 8C4, CANADA:
2,467,103, REN. 7-18-11, INT. CL. 8.
- TIMBERWOODS VACATION VILLAS, SARASOTA, FL:
4,015,726, PUB. 6-7-2011, INT. CL. 43.
- TIME OUT AMERICA LLC, NEW YORK, NY:
2,543,216, REN. 7-15-11, INT. CL. 35.
2,543,217, REN. 7-15-11, INT. CL. 35.
- TIMELY CONTACT, INC., WELLESLEY, MA:
4,015,451, PUB. 6-7-2011, INT. CL. 35.
- TIONG LIONG INDUSTRIAL CO., LTD., TAICHUNG HSIEN, TAIWAN:
4,016,790, INT. CL. 24.
- TISANE BOTANICAL BREWS LLC, LOS ANGELES, CA, DBA DISTIRA TISANES:
4,015,628, PUB. 6-7-2011, INT. CL. 30.
- TJX COMPANIES, INC., THE, FRAMINGHAM, MA:
2,503,076, REN. 7-21-11, INT. CL. 25.
- TJX COMPANIES, INC., THE, FRAMINGHAM, MA, TJX OPERATING COMPANIES, INC., THE, FRAMINGHAM, MA:
1,662,555, REN. 7-18-11, INT. CL. 25.
- TKG ENTERPRISES, INC., HOLSTEIN, IA:
2,910,521, CANC. INT. CL. 29.
- TKR SPEZIALWERKZEUGE GMBH, FED REP GERMANY:
4,014,577, PUB. 6-7-2011, MULTIPLE CLASS, INT. CLS. 7, 8, 9 AND 40.
- TM WEB PROPERTIES, LTD., LIMASSOL, CYPRUS:
4,015,868, PUB. 6-7-2011, INT. CL. 42.
- TMC WORLDWIDE, L.P., SANDIA, TX:
2,911,491, CANC. INT. CL. 37.
- TNEMEC COMPANY, INC., KANSAS CITY, MO:
4,016,405, INT. CL. 2.
- TNW CORPORATION, NEW YORK, NY:
3,420,031, AM. INT. CL. 16.

TOBIN, ELENA, CYPRESS, TX:
 4,015,443, PUB. 6-7-2011. INT. CL. 35.
 TODAY'S RESTAURANT NEWS, INC., BOCA RATON, FL:
 4,014,319, PUB. 6-7-2011. INT. CL. 16.
 TOKYOPOP INC., LOS ANGELES, CA:
 2,413,272, CANC. INT. CL. 16.
 TOLEDO PHYSICAL EDUCATION SUPPLY, INC., TOLEDO,
 OH:
 4,015,864, PUB. 6-7-2011. INT. CL. 35.
 TOLEJKO, PAUL, OJAI, CA:
 4,014,970, PUB. 6-7-2011. INT. CL. 25.
 TOM'S DRIVE IN OF AMERICA, INC., APPLETON, WI:
 2,910,058, CANC. INT. CL. 30.
 TOMAIN INVESTMENTS PTY LIMITED, AUSTRALIA:
 4,014,578, PUB. 6-7-2011. INT. CL. 7.
 TOMY COMPANY, KATSUSHIKA-KU, TOKYO, JAPAN:
 2,412,830, CANC. INT. CL. 28.
 TONG YANG INDUSTRY CO., LTD., TAINAN, TAIWAN:
 2,909,691, CANC. INT. CL. 12.
 TONNEMACHER, J. CRAIG, LOUISVILLE, KY, DBA J.
 CRAIG ENTERPRISES:
 2,141,136, CANC. INT. CL. 16.
 TOP CENTURY ENTERPRISES LTD., SIU LEK YUEN,
 SHATIN, NEW TERRITORIES, HONG KONG:
 2,910,466, CANC. INT. CL. 28.
 TOP GUN INTELLECTUAL PROPERTIES, LLC, ASTORIA,
 NY:
 4,014,412, PUB. 6-7-2011. INT. CL. 25.
 TOP TOBACCO L.P., GLENVIEW, IL:
 4,017,262, INT. CL. 7.
 4,017,265, INT. CL. 7.
 TOP VENDING INTERNATIONAL S.R.L., ROSTA, ITALY:
 2,909,978, CANC. INT. CL. 9.
 TORNADO COLLECTION LTD., NEW YORK, NY:
 2,910,926, CANC. INT. CL. 25.
 TORRASPAPEL, S.A., 08010 BARCELONA, SPAIN:
 1,654,302, REN. 7-21-11. INT. CL. 16.
 TOSS VERPACKUNGSSYSTEME GMBH & CO. KG, 35418
 ALTEN-BUSECK, FED REP GERMANY:
 4,015,691, PUB. 6-7-2011. INT. CL. 9.
 TOTAL COAT DE VENEZUELA, VALENCIA, ESTADO
 CARABOBO, VENEZUELA:
 2,911,667, CANC. INT. CL. 1.
 TOUT BOIS, MC-98000 MONACO, MONACO:
 3,879,266, COR. MULTIPLE CLASS, INT. CLS. 19 AND
 20.
 TOWER OIL & TECHNOLOGY CO., CHICAGO, IL, DBA
 TOWER OIL & TECHNOLOGY CO.:
 4,015,781, PUB. 6-7-2011. INT. CL. 4.
 TOY INVESTMENTS INC., SUMNER, WA, DBA TOYSMITH:
 4,015,249, PUB. 6-7-2011. INT. CL. 28.
 TOYO BOSEKI KABUSHIKI KAISHA, OSAKA, JAPAN:
 2,474,253, REN. 7-21-11. INT. CL. 22.
 TOYOTOMI AMERICA CORPORATION, SPRINGFIELD, KY:
 2,422,227, REN. 7-17-11. INT. CL. 40.
 2,449,997, REN. 7-16-11. INT. CL. 40.
 2,488,674, REN. 7-16-11. INT. CL. 40.
 TOYS IN BABELAND, SEATTLE, WA:
 2,909,993, CANC. INT. CL. 41.
 TPI HOLDINGS, INC., NORFOLK, VA:
 2,909,671, CANC. MULTIPLE CLASS, INT. CLS. 16 AND
 35.
 TRACE AMERICA, INC., NAPLES, FL:
 2,911,801, CANC. INT. CL. 45.
 TRACEY L. ROBINSON, PLAINFIELD, NJ:
 4,016,189, INT. CL. 16.
 TRACFONE WIRELESS, INC., MIAMI, FL:
 4,016,763, INT. CL. 35.
 4,016,764, INT. CL. 38.
 TRACK DATA CORPORATION, BROOKLYN, NY:
 4,016,037, PUB. 6-7-2011. INT. CL. 36.
 4,016,041, PUB. 6-7-2011. INT. CL. 36.
 TRADEBYTES DATA CORP., VANCOUVER, BRITISH CO-
 LUMBIA, CANADA:
 2,445,376, REN. 7-16-11. MULTIPLE CLASS, INT. CLS. 9
 AND 35.
 TRAILTEK, INC., VIRGINIA BEACH, VA:
 4,014,273, PUB. 6-7-2011. INT. CL. 28.
 TRAN JUDITH, WOODLAND HILLS, CA, DBA NAILISSI-
 MO:
 2,910,297, CANC. MULTIPLE CLASS, INT. CLS. 3 AND 8.
 TRAN, DIANE, SAN JOSE, CA, DBA OSOTUFFDOGTOYS-
 COM:
 4,016,423, INT. CL. 28.
 TRANEL FINANCIAL GROUP, INC., THE, LIBERTYVILLE,
 IL:
 2,552,095, REN. 7-15-11. INT. CL. 36.
 2,581,185, REN. 7-15-11. INT. CL. 36.
 TRANSCANADA PIPELINES LIMITED, CALGARY, AL-
 BERTA T2P 4K5, CANADA:
 2,909,379, CANC. MULTIPLE CLASS, INT. CLS. 35 AND
 39.
 TRANSCEND REALTY & DEVELOPMENT, HOUSTON, TX:
 2,911,110, CANC. MULTIPLE CLASS, INT. CLS. 36 AND
 37.
 TRANSDEV, BOULOGNE-BILLANCOURT 92652, FRANCE:
 2,910,282, CANC. MULTIPLE CLASS, INT. CLS. 35, 36, 39
 AND 42.
 TRANSFLO CORPORATION, JACKSONVILLE, FL:
 2,910,886, CANC. INT. CL. 39.
 TRANSLUMINA GMBH, 72379 HECHINGEN, FED REP
 GERMANY:
 2,909,492, CANC. INT. CL. 10.
 TRANSPARENT VISIBILITY HOLDINGS, LLC, BENTON-
 VILLE, AR:
 4,016,452, INT. CL. 45.
 TRANSPORTES CASTORES DE BAJA CALIFORNIA, S.A.
 DE C.V., GUANAJUATO, MEXICO:
 2,412,109, CANC. INT. CL. 39.
 TRANTER, EMMA, DELAND, FL:
 4,017,124, INT. CL. 41.
 TRAVEL AND TRANSPORT, INC., OMAHA, NE:
 2,494,202, REN. 7-18-11. INT. CL. 39.
 TRAVELPRO INTERNATIONAL, INC., BOCA RATON, FL:
 2,412,801, CANC. INT. CL. 18.
 2,514,199, REN. 7-18-11. INT. CL. 18.
 TREBETS, ED, CHESTERLAND, OH AND TREBETS, GINA,
 CHESTERLAND, OH:
 4,015,506, PUB. 6-7-2011. INT. CL. 33.
 TREE HOME MEDIA, VALLEY VILLAGE, CA:
 4,015,095, PUB. 6-7-2011. INT. CL. 41.
 4,015,101, PUB. 6-7-2011. INT. CL. 41.
 TREE SOUND STUDIOS, INC., NORCROSS, GA:
 4,014,675, PUB. 6-7-2011. INT. CL. 9.
 TREK AEROSPACE, INC., LOS ALTOS, CA:
 2,911,204, CANC. INT. CL. 12.
 TREMCO BARRIER SOLUTIONS, INC., REYNOLDSBURG,
 OH:
 2,469,845, REN. 7-19-11. INT. CL. 2.
 TREND PERSONNEL SERVICES, ROCKWALL, TX:
 4,015,554, PUB. 6-7-2011. INT. CL. 35.
 TRI-K INDUSTRIES, INC., NORTHVALE, NJ:
 2,910,646, CANC. MULTIPLE CLASS, INT. CLS. 1 AND 3.
 TRIGEN GMBH, D-82152 MARTINSRIED, FED REP GER-
 MANY:
 2,911,405, CANC. INT. CL. 42.
 TRIMARAN FUND MANAGEMENT, L.L.C., NEW YORK,
 NY:
 2,434,130, REN. 7-19-11. INT. CL. 36.
 TRIMBLE NAVIGATION LIMITED, SUNNYVALE, CA:
 2,909,930, CANC. INT. CL. 9.
 TRIODOS BANK N.V., 3704 HE ZEIST, NETHERLANDS
 AND TRIODOS ASSURANTIEN B.V., 3704 HE ZEIST,
 NETHERLANDS:
 2,909,672, CANC. INT. CL. 36.
 TRIPOLI ROCKETRY ASSOCIATION, INC., HIGHLANDS
 RANCH, CO:
 4,014,799, PUB. 6-7-2011. INT. CL. 41.
 TRISH MCEVOY, LTD, NEW YORK, NY:
 4,016,282, INT. CL. 3.
 4,016,283, INT. CL. 3.
 TRIUMPH PHARMACEUTICALS INC., ST. LOUIS, MO:
 4,016,166, INT. CL. 3.
 TROSCLAIR, PATRICIA ACERS, SAN RAFAEL, CA:
 2,910,810, CANC. INT. CL. 21.

- TROUBADOUR MUSIC INC., FERGUS, ONTARIO, CANADA:
1,687,867. REN. 7-19-11. INT. CL. 16.
- TRU-GLO, INC., RICHARDSON, TX:
2,476,944. REN. 7-16-11. INT. CL. 13.
- TRUCK-LITE CO., LLC, FALCONER, NY:
2,456,569. REN. 7-19-11. INT. CL. 11.
4,017,009. INT. CL. 11.
- TRUE NORTH ROCHESTER PREPARATORY CHARTER SCHOOL, ROCHESTER, NY:
4,015,322. PUB. 6-7-2011. INT. CL. 41.
- TRUE VALUE COMPANY, CHICAGO, IL:
4,014,436. PUB. 6-7-2011. MULTIPLE CLASS, INT. CLS. 1 AND 2.
- TRUFFLINA, LLC, PALO ALTO, CA:
4,015,839. PUB. 6-7-2011. INT. CL. 35.
- TRUGREEN LIMITED PARTNERSHIP, MEMPHIS, TN:
4,017,235. INT. CL. 44.
- TRUMP, DONALD J., NEW YORK, NY:
2,468,153. REN. 7-18-11. MULTIPLE CLASS, INT. CLS. 41 AND 42.
2,478,340. REN. 7-15-11. MULTIPLE CLASS, INT. CLS. 41 AND 42.
- TRUNK HEALTH, INC., SAN DIEGO, CA:
4,016,650. INT. CL. 10.
- TRUSTCORE INSURANCE AGENCY, INC., BRENTWOOD, TN:
2,411,818. CANC. INT. CL. 36.
- TRUSTED SYSTEMS, INC., SEVERNA PARK, MD:
2,563,785. REN. 7-15-11. INT. CL. 9.
- TSUBOHACHI CO. LTD., TAITO-KU, TOKYO, JAPAN:
2,909,535. CANC. INT. CL. 43.
- TSW, INC., OMAHA, NE, HOMER'S, INC., OMAHA, NE:
1,164,174. REN. 7-21-11. INT. CL. 42.
- TUCKER, TERENCE, SAN CLEMENTE, CA, DBA KLEEN-PAK SYSTEMS:
2,567,057. REN. 7-18-11. INT. CL. 21.
- TULLY RINCKEY P.L.L.C., ALBANY, NY:
4,014,783. PUB. 6-7-2011. INT. CL. 45.
- TULLY, DONALD J., SALISBURY, MA, DBA VELLOX COATINGS:
2,910,251. CANC. INT. CL. 2.
- TURNER NETWORK TELEVISION, INC., ATLANTA, GA:
4,016,800. INT. CL. 41.
- TUSKEGEE AIRMEN NATIONAL HISTORICAL MUSEUM, THE, DETROIT, MI:
4,016,150. MULTIPLE CLASS, INT. CLS. 16 AND 25.
- TUTOLI, DANIEL WARREN, SEMINOLE, FL:
2,581,380. REN. 7-19-11. INT. CL. 9.
- TUTTI PRODOTTI SICILIANI, INC., ANDOVER, MA:
2,911,430. CANC. MULTIPLE CLASS, INT. CLS. 29 AND 30.
- TUZA, YASIN, ANTALYA, TURKEY, TA KRAL AV:
4,015,007. PUB. 6-7-2011. INT. CL. 13.
- TV WINNERS, INC., MADISON, NJ:
4,016,966. INT. CL. 8.
- TVI CORPORATION, GLENN DALE, MD:
4,017,283. MULTIPLE CLASS, INT. CLS. 9 AND 11.
- TVN ENTERTAINMENT CORPORATION, SHERMAN OAKS, CA:
4,017,308. MULTIPLE CLASS, INT. CLS. 38 AND 41.
- TWENTIETH CENTURY FOX FILM CORPORATION, LOS ANGELES, CA:
2,459,918. REN. 7-21-11. INT. CL. 28.
4,016,719. INT. CL. 9.
4,017,284. INT. CL. 9.
- TWIN EAGLE RESOURCE MANAGEMENT, LLC, HOUSTON, TX:
4,017,221. MULTIPLE CLASS, INT. CLS. 35 AND 36.
- TWIN STAR INTERNATIONAL, INC., DELRAY BEACH, FL:
4,015,298. PUB. 6-7-2011. INT. CL. 11.
- TWISTED FARM, INC., SAN DIEGO, CA:
4,015,408. PUB. 6-7-2011. INT. CL. 43.
- TWO WHEEL MAFIA, LLC, GAINESVILLE, VA:
4,015,404. PUB. 6-7-2011. MULTIPLE CLASS, INT. CLS. 25 AND 40.
- TWO-ONE-TWO NEW YORK, INC., NEW YORK, NY:
2,460,054. REN. 7-19-11. INT. CL. 25.
- TXT MY REGISTRY, LLC, SANTA ANA, CA, DBA TXT MY REGISTRY:
4,016,129. PUB. 6-7-2011. INT. CL. 35.
- TXT MY REGISTRY, LLC, SANTA ANA, CA, DBA TXT OUR REGISTRY:
4,016,132. PUB. 6-7-2011. INT. CL. 35.
- TXU CORP., DALLAS, TX:
2,412,888. CANC. INT. CL. 42.
- TYCO HEALTHCARE GROUP LP, NEW HAVEN, CT:
1,661,282. REN. 7-20-11. INT. CL. 10.
2,384,067. REN. 7-21-11. INT. CL. 10.
2,390,275. REN. 7-21-11. INT. CL. 10.
- TYCO HEALTHCARE GROUP LP, NORWALK, CT:
2,911,460. CANC. INT. CL. 10.
- TYG DESIGNS, INC., GALVESTON, TX:
4,015,730. PUB. 6-7-2011. INT. CL. 14.
4,016,050. PUB. 6-7-2011. INT. CL. 14.
- TYSON FOODS, INC., SPRINGDALE, AR:
2,461,276. REN. 7-20-11. INT. CL. 35.
- U DAN-LING, GUANGZHOU GARMENT CO., LTD, CHINA:
4,014,642. PUB. 6-7-2011. INT. CL. 25.
- U.S. AND FOREIGN COMMERCIAL SERVICE, WASHINGTON, DC:
2,629,284. CANC. INT. CL. 35.
- U.S. EGG RESTAURANT, L.L.C., TEMPE, AZ:
2,535,875. REN. 7-20-11. INT. CL. 42.
- U.S. ELECTRONICS COMPONENTS CORP., PT. JEFFERSON STATION, NY:
2,909,347. CANC. INT. CL. 9.
- U.S. FOODSERVICE, INC., ROSEMONT, IL:
4,014,679. PUB. 6-7-2011. INT. CL. 30.
- U.S. HEALTH EQUIPMENT COMPANY, INC., KINGSTON, NY:
4,015,434. PUB. 6-7-2011. INT. CL. 11.
- U.S. MUSIC CORPORATION, MUNDELEIN, IL:
4,015,128. PUB. 6-7-2011. INT. CL. 9.
4,017,030. INT. CL. 15.
- U.S. ORTHOTICS, INC., TAMPA, FL:
4,015,773. PUB. 6-7-2011. INT. CL. 10.
- U.S. PAYMENTS, LLC, TULSA, OK:
4,014,740. PUB. 6-7-2011. MULTIPLE CLASS, INT. CLS. 9, 35 AND 36.
- U.S. PLY, INC., PORT ARTHUR, TX:
4,016,356. INT. CL. 19.
- U.S. POST CO., INC., SPRING GROVE, IL:
4,017,144. INT. CL. 6.
- U.S. TRAVEL ASSOCIATION, WASHINGTON, DC:
2,474,660. REN. 7-19-11. INT. CL. 35.
- U.S. VENTURE, INC., APPLETON, WI:
4,016,273. INT. CL. 30.
- UBIQUITY RECORDINGS, INC., COSTA MESA, CA:
2,484,315. REN. 7-16-11. INT. CL. 41.
- UDT GROUP, LLC, TALLAHASSEE, FL:
4,014,993. PUB. 6-7-2011. MULTIPLE CLASS, INT. CLS. 35, 42 AND 45.
- UHS OF DELAWARE, INC., KING OF PRUSSIA, PA:
2,909,837. CANC. INT. CL. 44.
2,909,838. CANC. INT. CL. 44.
4,016,124. PUB. 6-7-2011. INT. CL. 44.
4,016,768. INT. CL. 44.
4,016,803. INT. CL. 44.
4,016,818. INT. CL. 35.
4,016,908. INT. CL. 45.
- UHY ADVISORS, INC., CHICAGO, IL:
4,016,581. INT. CL. 41.
- ULIFE LTD, PORTLAND, OR:
4,015,934. PUB. 6-7-2011. INT. CL. 9.
4,016,110. PUB. 6-7-2011. INT. CL. 9.
- ULTRAFABRICS, LLC, TARRYTOWN, NY:
4,014,925. PUB. 6-7-2011. MULTIPLE CLASS, INT. CLS. 18 AND 24.
- ULTRAFRYER SYSTEMS, INC., SAN ANTONIO, TX:
2,581,797. REN. 7-18-11. INT. CL. 11.
- ULTRALIFE CORPORATION, NEWARK, NY:
2,593,294. REN. 7-15-11. INT. CL. 9.

ULTRAMAR ENERGY INC., SAN ANTONIO, TX:
2,910,563, CANC. MULTIPLE CLASS, INT. CLS. 35 AND 37.

ULTRAMARINE, LLC, RIDGEFIELD, CT:
4,016,761, MULTIPLE CLASS, INT. CLS. 29 AND 33.

ULTRATECH INTERNATIONAL, INC., JACKSONVILLE, FL:
2,473,755, REN. 7-19-11, INT. CL. 35.
2,473,756, REN. 7-19-11, INT. CL. 35.

ULUPONO INITIATIVE LLC, LOS GATOS, CA:
4,014,204, PUB. 6-7-2011, INT. CL. 36.

UMG RECORDINGS, INC., SANTA MONICA, CA TO UMG RECORDINGS, INC., SANTA MONICA, CA:
2,411,835, CANC. INT. CL. 9.
2,412,071, CANC. INT. CL. 9.

UNAVCO, INC., BOULDER, CO:
4,015,334, PUB. 6-7-2011, MULTIPLE CLASS, INT. CLS. 35, 37, 41 AND 42.

UNICOVER CORPORATION, THE, CHEYENNE, WY:
1,654,311, REN. 7-18-11, INT. CL. 16.

UNICOVER WORLD TRADE CORPORATION, CHEYENNE, WY:
1,676,275, REN. 7-15-11, INT. CL. 42.

UNIGROUP, INC., FENTON, MO:
4,016,454, INT. CL. 39.

UNIKEN BUSINESS SOLUTIONS, INC., ODESSA, FL:
4,014,355, PUB. 6-7-2011, INT. CL. 42.

UNION TELECOM, INC., CHICAGO, IL:
4,015,296, PUB. 6-7-2011, INT. CL. 16.

UNISA AMERICA, INC., MIAMI, FL:
2,910,018, CANC. INT. CL. 25.

UNISEN, INC., IRVINE, CA, DBA STAR TRAC:
2,467,955, REN. 7-19-11, INT. CL. 28.

UNITED AUBURN INDIAN COMMUNITY, LINCOLN, CA:
3,975,880, COR. INT. CL. 43.

UNITED BUSINESS MEDIA LLC, MANHASSET, NY:
4,016,279, INT. CL. 9.

UNITED CUTLERY CORPORATION, THOMASVILLE, GA:
2,412,765, CANC. INT. CL. 8.
2,911,705, CANC. INT. CL. 8.

UNITED DAIRY FARMERS, INC., CINCINNATI, OH:
2,505,554, REN. 7-16-11, INT. CL. 30.

UNITED HARDWARE DISTRIBUTING CO, MINNEAPOLIS, MN:
2,511,868, REN. 7-19-11, INT. CL. 8.

UNITED INDUSTRIES CORPORATION, EARTH CITY, MO, GEIGY CHEMICAL CORPORATION, ARDSLEY, NY:
716,317, REN. 7-19-11, U.S. CL. 6 (INT. CL. 5).

UNITED KENNEL CLUB, INC., KALAMAZOO, MI:
4,015,501, PUB. 6-7-2011, MULTIPLE CLASS, INT. CLS. 16, 35 AND 41.

UNITED SHIPPING SOLUTIONS, MIDVALE, UT:
3,871,854, CANC. IIRN. RESTORED TO S.N. 77-406,740.

UNITED SPORTS TECHNOLOGIES, LP, FORT WORTH, TX, DBA UST MAMIYA:
4,015,708, PUB. 6-7-2011, INT. CL. 28.

UNITED STATES FUND FOR UNICEF, NEW YORK, NY:
2,464,779, REN. 7-16-11, MULTIPLE CLASS, INT. CLS. 36 AND 42.

UNITED STATES OLYMPIC COMMITTEE, COLORADO SPRINGS, CO:
4,016,109, PUB. 6-7-2011, INT. CL. 36.

UNITED STATES STEEL CORPORATION, PITTSBURGH, PA:
2,469,301, REN. 7-19-11, INT. CL. 6.

UNITED STATIONERS SUPPLY CO., DES PLAINES, IL:
2,911,261, CANC. INT. CL. 9.

UNITED STEEL PRODUCTS COMPANY, INC., MONTGOMERY, MN:
2,816,784, COR. INT. CL. 9.
2,929,329, COR. MULTIPLE CLASS, INT. CLS. 6 AND 9.
2,990,979, COR. INT. CL. 6.

UNITED STEEL PRODUCTS COMPANY, INC., BURNSVILLE, MN:
3,246,005, COR. INT. CL. 1.
3,246,006, COR. INT. CL. 9.
3,250,334, COR. INT. CL. 6.
3,358,423, COR. INT. CL. 1.
3,503,161, COR. INT. CL. 6.

UNITRON HEARING LTD., KITCHENER, ONTARIO, CANADA:
2,909,458, CANC. INT. CL. 10.

UNIVERSAL BIOLOGICS GLOBAL, INC., SAN FRANCISCO, CA:
2,413,234, CANC. INT. CL. 3.

UNIVERSAL CITY STUDIOS LLC, UNIVERSAL CITY, CA:
4,017,015, INT. CL. 35.

UNIVERSAL ENTERTAINMENT CORPORATION, JAPAN:
4,014,580, PUB. 6-7-2011, MULTIPLE CLASS, INT. CLS. 9 AND 28.

UNIVERSAL MANUFACTURING CO., INC., KANSAS CITY, MO:
2,911,157, CANC. INT. CL. 28.

UNIVERSAL MELODY SERVICES, DALLAS, TX, DBA BROOK MAYS MUSIC AND H&H MUSIC:
2,412,077, CANC. MULTIPLE CLASS, INT. CLS. 35, 37 AND 41.

UNIVERSAL PROTECTION SERVICE, LP, SANTA ANA, CA:
4,015,222, PUB. 6-7-2011, INT. CL. 45.

UNIVERSITY OF CENTRAL FLORIDA, ORLANDO, FL:
2,909,952, CANC. INT. CL. 16.

UNIVERSITY OF NEW HAMPSHIRE SCHOOL OF LAW, CONCORD, NH, GEORGE WASHINGTON UNIVERSITY, THE, WASHINGTON, DC:
913,629, REN. 7-15-11, U.S. CL. 38 (INT. CL. 16).

UNIVERSITY OF NORTHERN IOWA, CEDAR FALLS, IA:
4,014,315, PUB. 3-1-2011, MULTIPLE CLASS, INT. CLS. 9 AND 41.
4,014,324, PUB. 6-7-2011, INT. CL. 9.

UNIVERSITY OF PITTSBURGH -OF THE COMMONWEALTH SYSTEM OF HIGHER EDUCATION, PITTSBURGH, PA:
4,015,150, PUB. 6-7-2011, MULTIPLE CLASS, INT. CLS. 14 AND 41.

UNIVEST CORPORATION OF PENNSYLVANIA, SOUDERTON, PA:
4,017,232, INT. CL. 36.
4,017,247, INT. CL. 36.

UNOARRE INDUSTRIES S.P.A., AREZZO, ITALY:
913,294, REN. 7-15-11, U.S. CL. 28 (INT. CL. 14).

UPFRONT FOODS, LLC, BOCA RATON, FL:
4,017,269, INT. CL. 30.

UPSOLUT MICHAEL VEITH MARKETING GMBH, MÜNCHEN, FED REP GERMANY:
2,910,680, CANC. INT. CL. 41.

URBAN DECAY COSMETICS LLC, NEWPORT BEACH, CA:
4,016,058, PUB. 6-7-2011, INT. CL. 3.
4,016,059, PUB. 6-7-2011, INT. CL. 35.
4,016,064, PUB. 6-7-2011, INT. CL. 3.
4,017,084, INT. CL. 44.
4,017,085, INT. CL. 44.

URBAN ENTERPRISES, LLC, DES MOINES, IA:
4,015,713, PUB. 6-7-2011, INT. CL. 35.

URODA, SUSAN, CARLSBAD, CA:
3,588,790, AM. INT. CL. 25.

URS GASSMANN, SWITZERLAND:
4,014,639, PUB. 6-7-2011, MULTIPLE CLASS, INT. CLS. 11, 35 AND 44.

US ANGLERS ASSOCIATION, INC., ATLANTIC BEACH, NC:
2,909,670, CANC. MULTIPLE CLASS, U.S. CL. 200 INT. CLS. 35 AND 41.

US NORDICLEAN, INC., WASHINGTON, DC:
2,910,383, CANC. INT. CL. 11.

USADATA, INC., NEW YORK, NY:
4,015,910, PUB. 6-7-2011, INT. CL. 35.

USADATA, INC., NEW YORK, NY:
4,015,908, PUB. 6-7-2011, INT. CL. 35.

USG INTERIORS, INC., CHICAGO, IL:
4,015,757, PUB. 6-7-2011, INT. CL. 6.

- USGI MEDICAL, INC., SAN CLEMENTE, CA:
2,910,918, CANC. INT. CL. 10.
- USP LLC, OCEANSIDE, CA:
4,016,997, INT. CL. 16.
- USVP MANAGEMENT COMPANY LLC, MENLO PARK, CA:
2,531,857, REN. 7-15-11. INT. CL. 36.
- UTAK LABORATORIES, INC., VALENCIA, CA:
4,015,005, PUB. 6-7-2011. INT. CL. 42.
- UTC FIRE & SECURITY AMERICAS CORPORATION, INC., FARMINGTON, CT:
2,412,073, CANC. INT. CL. 9.
- UTHERVERSE, INC., ZEPHR COVE, NV:
4,017,280, INT. CL. 42.
- UTI ASSET MANAGEMENT COMPANY LIMITED, BANDRA (EAST), INDIA:
4,014,285, PUB. 6-7-2011. INT. CL. 36.
- UTOPIA, LLC, CHICAGO, IL:
4,016,828, INT. CL. 41.
4,016,829, INT. CL. 42.
- UV2U TECHNOLOGIES, LLC, BURLINGTON, WI:
4,016,444, INT. CL. 37.
- V & C, LLC, GOLDENDALE, WA:
4,016,337, INT. CL. 33.
- V & H HOLDINGS LLC, GILBERT, AZ:
4,016,769, INT. CL. 35.
- V-DAY CORPORATION, NEW YORK, NY:
4,015,791, PUB. 6-7-2011. INT. CL. 36.
- VA BIEN INTERNATIONAL, INC., AGUAS BUENAS, PUERTO RICO:
4,016,116, PUB. 6-7-2011. INT. CL. 25.
- VECTOR MANUFACTURING, INC., STREATOR, IL:
2,488,617, REN. 7-18-11. INT. CL. 7.
- VACUMET CORP., IRVINE, CA:
1,161,887, REN. 7-18-11. INT. CL. 16.
- VADAKAN-MYUNG, LOS ANGELES, CA:
4,016,572, INT. CL. 25.
- VAINORIUS, ENRIKAS, MORRISVILLE, NC:
4,015,750, PUB. 6-7-2011. INT. CL. 42.
- VALDAMOR, S.A., 36968 XIL-MEANO PONTEVEDRA, SPAIN:
2,467,467, REN. 7-18-11. INT. CL. 33.
- VALERIA RONCOLI STUDIO LLC, NEW HAVEN, CT:
3,859,223, CANC. INT. CL. 25.
- VALLEY FORGE FABRICS INC, POMPANO BEACH, FL:
4,014,800, PUB. 6-7-2011. INT. CL. 24.
- VALLEY TELEPHONE COOPERATIVE, INC., WILLCOX, AZ:
2,909,959, CANC. INT. CL. 38.
- VALTEC GROUP, INC., MORGANTOWN, WV:
2,413,268, CANC. INT. CL. 35.
- VALUE FORWARD GROUP, INC., PEACHTREE CITY, GA:
4,017,339, INT. CL. 41.
- VALUE QUEST FOODS, ST. CLAIR SHORES, MI:
4,017,052, INT. CL. 30.
- VALUERAT, INC., SPRING, TX:
2,911,196, CANC. INT. CL. 35.
- VANDERSTERRE GROEP INTERNATIONAL B.V., NETHERLANDS:
4,014,647, PUB. 6-7-2011. INT. CL. 29.
- VANI U.S.A., INC., NEW YORK, NY:
4,016,914, INT. CL. 9.
4,016,931, MULTIPLE CLASS, INT. CLS. 9 AND 14.
4,017,002, MULTIPLE CLASS, INT. CLS. 18 AND 25.
- VAPOR POWER INTERNATIONAL, LLC, FRANKLIN PARK, IL:
4,016,224, INT. CL. 11.
- VARCO I/P, INC., HOUSTON, TX, YOUNGSTOWN SHEET AND TUBE COMPANY, YOUNGSTOWN, OH:
912,302, REN. 7-19-11. U.S. CL. 13 (INT. CL. 17).
- VARIASIAN DEVELOPMENT, LTD., KOWLOON, HONG KONG:
2,910,463, CANC. MULTIPLE CLASS, INT. CLS. 29 AND 30.
- VARILOC PRODUCTS, LLC, MILLINGTON, MI:
2,320,319, CANC. INT. CL. 7.
- VARSHNEY, ANURAG, ISELIN, NJ:
4,015,854, PUB. 6-7-2011. INT. CL. 41.
- VECCO TECHNOLOGY INC., MALVERN, PA:
2,909,439, CANC. INT. CL. 9.
- VEECO METROLOGY INC., SANTA BARBARA, CA:
4,014,749, PUB. 6-7-2011. INT. CL. 9.
- VELVET YOGURT, INC., FOOTHILL RANCH, CA:
4,014,909, PUB. 6-7-2011. INT. CL. 35.
- VEN-MAR SALES, INC., SCIOTA, PA:
4,014,904, PUB. 6-7-2011. INT. CL. 6.
- VENKAT RAMASWAMY, FALLS CHURCH, VA:
4,016,201, INT. CL. 38.
- VENTAS, INC., CHICAGO, IL:
4,016,090, PUB. 6-7-2011. MULTIPLE CLASS, INT. CLS. 36 AND 37.
- VENTRIA BIOSCIENCE, FORT COLLINS, CO:
4,015,873, PUB. 6-7-2011. INT. CL. 1.
- VENTURE COMMUNICATIONS I, INC., LUBBOCK, TX:
2,909,961, CANC. INT. CL. 38.
- VENTUREDYNE, LTD., HOLLAND, MI:
2,477,163, REN. 7-18-11. INT. CL. 9.
- VENUS FASHION, INC., JACKSONVILLE, FL:
4,014,751, PUB. 6-7-2011. INT. CL. 25.
- VENZA LEARNING SOLUTIONS, INC., ALPHARETTA, GA:
4,014,378, PUB. 6-7-2011. MULTIPLE CLASS, INT. CLS. 9 AND 42.
4,014,379, PUB. 6-7-2011. MULTIPLE CLASS, INT. CLS. 9 AND 42.
4,014,380, PUB. 6-7-2011. MULTIPLE CLASS, INT. CLS. 9 AND 42.
- VERIGEN AG, FED REP GERMANY:
2,909,459, CANC. MULTIPLE CLASS, INT. CLS. 5 AND 42.
- VERISIGN, INC., MOUNTAIN VIEW, CA:
2,909,555, CANC. MULTIPLE CLASS, INT. CLS. 38, 39 AND 42.
- VERISTIC TECHNOLOGIES, INC., HOUSTON, TX:
4,014,235, PUB. 6-7-2011. INT. CL. 7.
- VERIZON TRADEMARK SERVICES LLC, ARLINGTON, VA:
4,016,510, INT. CL. 43.
- VERSATILE CLOTHING, LLC, PHILADELPHIA, PA:
2,909,773, CANC. INT. CL. 25.
- VERSUS, L.P., PHILADELPHIA, PA:
2,911,800, CANC. INT. CL. 41.
- VESUVIUS CRUCIBLE COMPANY, PITTSBURGH, PA:
2,463,912, REN. 7-18-11. MULTIPLE CLASS, INT. CLS. 1, 17 AND 19.
- VETERANS OF VALOR, INC., INDIANAPOLIS, IN:
4,014,417, PUB. 3-1-2011. MULTIPLE CLASS, INT. CLS. 36 AND 45.
4,014,418, PUB. 3-1-2011. MULTIPLE CLASS, INT. CLS. 36 AND 45.
- VFINANCE HOLDINGS, INC., BOCA RATON, FL:
2,412,596, CANC. INT. CL. 36.
- VHA INC., IRVING, TX:
4,016,497, MULTIPLE CLASS, INT. CLS. 35 AND 44.
- VHS CHILDREN'S HOSPITAL OF MICHIGAN, INC., NASHVILLE, TN:
4,015,200, PUB. 6-7-2011. INT. CL. 44.
- VI GROUP PLC, STROUD, GLOUCESTERSHIRE, ENGLAND:
2,412,205, CANC. INT. CL. 9.
2,412,208, CANC. INT. CL. 9.
- VIACOM INTERNATIONAL INC., NEW YORK, NY:
4,014,420, PUB. 3-1-2011. INT. CL. 24.
- VIBRAM S.P.A., ALBIZZATE (VARESE), ITALY:
1,656,869, REN. 7-16-11. INT. CL. 25.
- VICARAGE MOTORCARS, INC., MIAMI BEACH, FL:
2,411,965, CANC. INT. CL. 12.
- VICERE ASSOCIATES, INC., STATE COLLEGE, PA:
2,909,714, CANC. INT. CL. 35.
- VICEROY HOTELS, L.L.C., LOS ANGELES, CA:
4,016,231, MULTIPLE CLASS, INT. CLS. 41 AND 43.
- VICTORIA'S SECRET DIRECT BRAND MANAGEMENT, LLC, REYNOLDSBURG, OH:
2,910,942, CANC. INT. CL. 35.

VICTORIA'S SECRET STORES BRAND MANAGEMENT, INC., REYNOLDSBURG, OH:
4,016,558, INT. CL. 3.
4,017,183, INT. CL. 3.

VICTORY MEDIA, INC., CORAOPOLIS, PA:
4,015,529, PUB. 6-7-2011. INT. CL. 41.

VIDA Y ESTILO, CORP., MIAMI BEACH, FL:
4,015,619, PUB. 6-7-2011. INT. CL. 43.
4,016,891, INT. CL. 43.

VIDACARE CORPORATION, SHAVANO PARK, TX:
4,016,519, INT. CL. 42.

VIDOVATION CORPORATION, ALISO VIEJO, CA:
4,016,985, MULTIPLE CLASS, INT. CLS. 9, 38 AND 42.

VIGNOLO; C. J., SHAFER, CA, DBA VIGNOLO FARMS:
1,198,178. REN. 7-16-11. INT. CL. 31.

VILLA MARIA ESTATE LIMITED, MANGERE AUCKLAND, NEW ZEALAND:
4,016,666, INT. CL. 33.

VILLAGE FOX, LAKEWOOD, TN:
4,016,324, INT. CL. 16.
4,016,329, INT. CL. 35.

VILLAGE OF HOFFMAN ESTATES, HOFFMAN ESTATES, IL:
4,016,978, MULTIPLE CLASS, INT. CLS. 35 AND 41.

VINA ALTAIR S.A., VITACURA, SANTIAGO, CHILE:
2,910,390, CANC. INT. CL. 32.

VINA CANTERA S.A., CHIMBARONGO, CHILE:
2,911,406, CANC. INT. CL. 33.

VINCENT MOTORS U.S.A., RANCHO SANTA FE, CA:
2,911,336, CANC. INT. CL. 12.

VINEGAR, DEREK LEE, LAREDO, TX, AKA DISCIPLE OF THE KING:
4,015,817, PUB. 6-7-2011. INT. CL. 9.

VIRANI INTERNATIONAL HOLDINGS LTD., WEST VANCOUVER, B.C., CANADA:
4,014,428, PUB. 5-18-2010. INT. CL. 16.

VIRBAC, FRANCE:
4,014,513, PUB. 6-7-2011. INT. CL. 5.

VIRGINIA FINANCIAL GROUP, INC., CULPEPER, VA:
2,910,000, CANC. INT. CL. 36.

VIRGO PUBLISHING, LLC, PHOENIX, AZ:
4,016,062, PUB. 6-7-2011. INT. CL. 41.

VIROPHARMA INCORPORATED, EXTON, PA, VIROPHARMA INCORPORATED, EXTON, PA:
2,457,511. REN. 7-16-11. INT. CL. 5.
2,459,907. REN. 7-16-11. INT. CL. 5.

VIRTUAL GEOSATELLITE, L.L.C., WASHINGTON, DC:
2,385,782, CANC. INT. CL. 25.

VIRTUAL POWER PLANT, HANAIEI, HI:
4,014,415, PUB. 7-27-2010. INT. CL. 35.

VIRTUAL TECHNOLOGY, INC., TROY, MI:
1,654,504. REN. 7-21-11. MULTIPLE CLASS, INT. CLS. 37 AND 42.

VISCOSITY, INC., SAN DIEGO, CA:
2,910,299, CANC. MULTIPLE CLASS, INT. CLS. 41 AND 43.

VISIONIX LTD., JERUSALEM, ISRAEL:
4,015,109, PUB. 6-7-2011. INT. CL. 9.

VISIONOPS, HIGHLANDS RANCH, CO:
2,910,799, CANC. MULTIPLE CLASS, INT. CLS. 35 AND 41.

VISITREND, LLC, AUBURNDALE, MA:
4,015,996, PUB. 6-7-2011. INT. CL. 9.

VIVACITYLIFE, LLC, SCARBOROUGH, ME:
4,017,317, INT. CL. 34.

VIVAGEN HEALTH PRODUCTS, GAINESVILLE, FL:
2,910,817, CANC. INT. CL. 35.

VIVEVITA, LLC, CHARLOTTE, NC:
4,017,019, INT. CL. 21.
4,017,020, MULTIPLE CLASS, INT. CLS. 20 AND 24.
4,017,022, INT. CL. 5.

VIVID ENTERTAINMENT LLC, LOS ANGELES, CA:
2,909,730, CANC. INT. CL. 41.

VKR HOLDING A/S, 2970 HØRSBOLM, DENMARK:
2,474,125. REN. 7-21-11. MULTIPLE CLASS, INT. CLS. 6 AND 19.

VLOGIC, INC., FREDERICK, CO:
2,461,042, CANC. INT. CL. 42.

VMCS, INC., NEW YORK, NY:
4,014,986, PUB. 6-7-2011. INT. CL. 41.
4,015,119, PUB. 6-7-2011. INT. CL. 41.
4,015,158, PUB. 6-7-2011. INT. CL. 41.

VN CORP., GREENVILLE, DE:
4,015,108, PUB. 6-7-2011. MULTIPLE CLASS, INT. CLS. 37 AND 42.

VO GROUP, LLC, EGG HARBOR TOWNSHIP, NJ, DBA VACATION OWNERSHIP GROUP:
4,017,417, INT. CL. 36.

VOCO GMBH, 27472 CUXHAVEN, FED REP GERMANY:
4,014,519, PUB. 6-7-2011. INT. CL. 5.

VOIVOD, SAN FRANCISCO, CA:
2,909,660, CANC. INT. CL. 9.

VOLI SPIRITS, LLC, WEST HOLLYWOOD, CA:
4,017,423, INT. CL. 33.

VOLK OPTICAL, INC., MENTOR, OH:
1,683,645. REN. 7-21-11. INT. CL. 9.

VOLUBILIS FOODS, INC., WATERBURY, CT:
4,015,025, PUB. 6-7-2011. INT. CL. 29.

VOLUNTEER CENTER OF NORTH TEXAS, THE, DALLAS, TX:
2,909,590, CANC. INT. CL. 42.

VOLVO TRADEMARK HOLDING AB, GSE-405 08 GÖTEBORG, SWEDEN:
1,159,454. REN. 7-20-11. INT. CL. 39.

VON SCHACK, REGINA, NEW YORK, NY:
4,016,791, INT. CL. 26.

VOROS, MELANIE B, MRS, BEDFORD, NH, DBA BLISSFUL BEGINNINGS:
2,459,628. REN. 7-15-11. INT. CL. 42.

VORWERK INTERNATIONAL AG, 8832 WOLLERAU, SWITZERLAND:
2,467,405. REN. 7-19-11. MULTIPLE CLASS, INT. CLS. 7, 16 AND 21.

VOTHOLE HOLDINGS PTY. LIMITED (ACN 100 028 153), BROOKVALE, NEW SOUTH WALES, AUSTRALIA:
2,910,371, CANC. INT. CL. 8.

VOYAGER ESTATE [WA] PTY LTD, COTTESLOE, WESTERN AUSTRALIA, 6011, AUSTRALIA:
2,535,324, AM. MULTIPLE CLASS, INT. CLS. 16, 21 AND 33.

VSAT SYSTEMS, LLC, AKRON, OH:
4,015,127, PUB. 6-7-2011. MULTIPLE CLASS, INT. CLS. 9 AND 38.

W. W. GRAINGER, INC., LAKE FOREST, IL:
2,468,003. REN. 7-18-11. INT. CL. 16.

WAGNER, GREGORY, VALENCIA, PA:
4,015,891, PUB. 6-7-2011. INT. CL. 41.

WAGONHEIM & ASSOCIATES, LLC, HUNT VALLEY, MD, DBA THE WAGONHEIM LAW FIRM:
4,015,274, PUB. 6-7-2011. INT. CL. 45.

WAH YAT IMPORT & EXPORT, INC., SAN FRANCISCO, CA:
2,479,139. REN. 7-18-11. INT. CL. 30.

WAKE FOREST UNIVERSITY, WINSTON-SALEM, NC:
2,891,646, COR. INT. CL. 41.
4,015,036, PUB. 6-7-2011. INT. CL. 41.

WAKEFERN FOOD CORP., KEASBEY, NJ:
4,016,054, PUB. 6-7-2011. INT. CL. 41.
4,016,055, PUB. 6-7-2011. INT. CL. 41.

WAKUNAGA OF AMERICA CO., LTD., MISSION VIEJO, CA:
2,564,102. REN. 7-19-11. INT. CL. 5.

WAL-MART STORES, INC., BENTONVILLE, AR:
2,576,402. REN. 7-18-11. INT. CL. 32.
2,911,477, CANC. INT. CL. 25.

WALDEMAR LINK GMBH & CO. KG, 22339 HAMBURG, FED REP GERMANY:
2,954,240, CANC. INT. CL. 9.

WALDORF TECHNIK GMBH & CO. KG, 78234 ENGEN, FED REP GERMANY:
4,014,462, PUB. 6-7-2011. INT. CL. 7.
4,014,463, PUB. 6-7-2011. INT. CL. 7.

WALLACE, CHRISTOPHER, FOOHILL RANCH, CA:
4,015,663, PUB. 6-7-2011. INT. CL. 30.

WALLACE, WILLIAM L., MCCLELLANVILLE, SC:
4,015,382, PUB. 6-7-2011. INT. CL. 7.

- WALT DISNEY PRODUCTIONS, BURBANK, CA TO DISNEY ENTERPRISES, INC., BURBANK, CA:
1,189,727, CANC. MULTIPLE CLASS, INT. CLS. 9, 11, 18 AND 20.
- WALTERS, BARRY J., TOWNSVILLE NORTH QUEENSLAND 4818, AUSTRALIA AND WALTERS, SHIRLEY A., TOWNSVILLE NORTH QUEENSLAND 4818, AUSTRALIA:
2,909,553, CANC. INT. CL. 25.
- WALTON STREET BREWING CORP., SYRACUSE, NY, DBA EMPIRE BREWING COMPANY:
4,014,713, PUB. 6-7-2011. INT. CL. 29.
- WANG LIZHONG, CHINA:
4,014,533, PUB. 6-7-2011. MULTIPLE CLASS, INT. CLS. 25 AND 35.
- WANG WEI, GUANGDONG PROVINCE, CHINA:
4,016,907, INT. CL. 43.
- WANGO WORLD INC., CALGARY, ALBERTA, T3C 2E6, CANADA:
2,909,402, CANC. MULTIPLE CLASS, INT. CLS. 9 AND 41.
- WANHONG GROUP CO., LTD., ZHEJIANG PROVINCE, CHINA:
4,014,616, PUB. 6-7-2011. INT. CL. 7.
- WARNER BROS. ENTERTAINMENT INC., BURBANK, CA, WARNER BROS. PICTURES, INC., NEW YORK, NY:
391,866. REN. 7-15-11. U.S. CL. 26 (INT. CL. 9).
- WARNER CHILCOTT COMPANY, LLC, FAJARDO, PUERTO RICO:
4,015,290, PUB. 6-7-2011. INT. CL. 5.
- WARNER/CHAPPELL PRODUCTION MUSIC, INC., LOS ANGELES, CA:
4,016,557, INT. CL. 41.
4,016,574, INT. CL. 41.
- WASH DEPOT HOLDINGS, INC., MALDEN, MA:
2,548,840. REN. 7-18-11. INT. CL. 37.
- WASHINGTON MAGAZINE, INC., WASHINGTON, DC:
4,014,827, PUB. 6-7-2011. INT. CL. 16.
- WASHINGTON WINE AND BEVERAGE COMPANY, WOODINVILLE, WA:
4,016,677, INT. CL. 33.
- WASTE MANAGEMENT, INC., HOUSTON, TX:
4,016,924, INT. CL. 7.
4,016,925, MULTIPLE CLASS, INT. CLS. 37 AND 39.
4,017,048, INT. CL. 40.
- WATCH CLUB INC, VERNON, CA, DBA TECTRON INTERNATIONAL:
4,015,337, PUB. 6-7-2011. INT. CL. 21.
- WATCH CLUB INC., LOS ANGELES, CA:
2,526,851. REN. 7-16-11. INT. CL. 8.
- WATER POINTE REALTY GROUP OF STUART, INC., STUART, FL:
2,910,885, CANC. INT. CL. 36.
- WATER WITHOUT BORDERS, CORP., PLEASANT VALLEY, NY:
4,015,567, PUB. 6-7-2011. INT. CL. 36.
- WATERMAN LEAGUE LTD., LONDON, ENGLAND, UNITED KINGDOM:
4,014,374, PUB. 6-7-2011. INT. CL. 41.
- WATERMOOR GROUP LIMITED., BOHEMIA, NY:
2,456,877. REN. 7-16-11. INT. CL. 42.
- WATERS, JAMES R., HOUSTON, TX:
2,483,496. REN. 7-19-11. INT. CL. 36.
- WATERSHED INNOVATIONS, SANTA CLARA, CA, DBA WATERSHED INNOVATIONS:
4,014,716, PUB. 6-7-2011. INT. CL. 19.
- WATLOW ELECTRIC MANUFACTURING COMPANY, ST. LOUIS, MO:
388,227. REN. 7-19-11. U.S. CL. 21 (INT. CL. 11).
- WATSON PHARMACEUTICALS, INC., CORONA, CA:
2,911,459, CANC. INT. CL. 5.
- WATSON, JILL, SAN CLEMENTE, CA, DBATHE PAMPERED BRIDE:
4,016,889, INT. CL. 25.
- WATT PUBLISHING COMPANY, ROCKFORD, IL:
921,163. REN. 7-16-11. U.S. CL. 38 (INT. CL. 16).
- WAVERRIDER COMMUNICATIONS (CANADA) INC., TORONTO, ONTARIO, CANADA TO VECIMA NETWORKS INC., VICTORIA, CANADA:
2,411,651, CANC. INT. CL. 38.
- WAVETRONIX LLC, LINDON, UT:
4,017,295, INT. CL. 9.
- WAYS GO CORPORATION, SAN FRANCISCO, CA:
4,016,820, MULTIPLE CLASS, INT. CLS. 35 AND 45.
- WBN LIMITED, REDWOOD CITY, CA:
4,014,962, PUB. 6-7-2011. INT. CL. 36.
- WBS HOCKEY LP, WILKES-BARRE, PA:
3,041,194, AM. MULTIPLE CLASS, INT. CLS. 25 AND 41.
- WE HOLDINGS LLC, NEW YORK, NY:
4,015,942, PUB. 6-7-2011. INT. CL. 36.
- WEATHER SHIELD MFG., INC., MEDFORD, WI:
2,413,116, CANC. INT. CL. 19.
- WEATHERFORD/LAMB, INC., HOUSTON, TX:
2,455,348. REN. 7-15-11. INT. CL. 7.
- WEAVER OFFICIAL PUBLICATIONS, INC., DENVER, CO:
2,909,956, CANC. INT. CL. 41.
- WEBCODE LTD, AKKO, ISRAEL:
4,015,259, PUB. 6-7-2011. INT. CL. 38.
- WEBCOLLECT, INC., FORT LAUDERDALE, FL:
4,015,278, PUB. 6-7-2011. MULTIPLE CLASS, INT. CLS. 9 AND 42.
- WEBER, OLIVER, BIG BEAR LAKE, CA:
2,910,877, CANC. INT. CL. 14.
- WEBPOWER, INC., LAKE WORTH, FL:
4,016,104, PUB. 6-7-2011. INT. CL. 41.
4,016,106, PUB. 6-7-2011. INT. CL. 9.
- WEDORABLE LLC, STATEN ISLAND, NY:
4,016,964, INT. CL. 41.
- WEEKENDS, INC., LEXINGTON, MI:
2,468,651. REN. 7-18-11. INT. CL. 35.
- WEIDER PUBLICATIONS, LLC, BOCA RATON, FL:
2,910,852, CANC. INT. CL. 16.
- WEIGEL BROADCASTING CO., CHICAGO, IL:
2,910,543, CANC. MULTIPLE CLASS, INT. CLS. 38 AND 41.
- WEIGEL STORES, INC., POWELL, TN:
4,015,057, PUB. 6-7-2011. INT. CL. 32.
- WEIR MINERALS NETHERLANDS B.V., VENLO, NETHERLANDS:
4,014,466, PUB. 6-7-2011. INT. CL. 7.
- WELLAM INVESTMENT LIMITED, CENTRAL, HONG KONG:
2,910,883, CANC. INT. CL. 36.
- WELLS ENTERPRISES, INC., LE MARS, IA:
2,911,130, CANC. INT. CL. 35.
- WELLS FARGO & COMPANY, SAN FRANCISCO, CA:
2,411,631, CANC. MULTIPLE CLASS, INT. CLS. 16 AND 36.
- WELLS FARGO & COMPANY, MINNEAPOLIS, MN:
2,540,523. REN. 7-18-11. INT. CL. 28.
- WELLS LAMONT INDUSTRY GROUP LLC, NILES, IL:
4,015,802, PUB. 6-7-2011. INT. CL. 9.
- WERNER CHRIST GMBH, FED REP GERMANY:
3,960,806, COR. MULTIPLE CLASS, INT. CLS. 12, 18, 20, 24 AND 25.
- WESCOTT, JOSEPH M., CONCORD, NH:
2,413,284, CANC. INT. CL. 16.
- WEST PUBLISHING CORPORATION, EAGAN, MN:
4,016,551, INT. CL. 42.
- WEST RESTAURANT GROUP, L.L.C., HOUSTON, TX, DBA GREATFULL TACO:
4,017,195, INT. CL. 43.
- WESTERN LEATHER GOODS, INC., MERCEDES, TX:
2,507,016. REN. 7-18-11. INT. CL. 25.
- WESTERN MONEY SYSTEMS, SPARKS, NV:
4,014,976, PUB. 6-7-2011. INT. CL. 9.
- WESTERN PETROLEUM ENTERPRISES, INC., MAYAGUEZ, PUERTO RICO:
2,909,964, CANC. INT. CL. 4.
- WESTFIELD, LLC, LOS ANGELES, CA:
4,016,327, MULTIPLE CLASS, INT. CLS. 35, 41, 43 AND 45.
4,016,710, MULTIPLE CLASS, INT. CLS. 41 AND 43.

WESTRIM, INC., VAN NUYS, CA:
2,910,021, CANC. INT. CL. 16.

WF ACQUISITION, INC., COLORADO SPRINGS, CO:
2,412,805, CANC. INT. CL. 8.

WGBH EDUCATIONAL FOUNDATION, BOSTON, MA:
2,911,337, CANC. MULTIPLE CLASS, INT. CLS. 9 AND 28.

WHAM-O, INC., EMERYVILLE, CA:
2,412,838, CANC. INT. CL. 28.

WHAT'S YOUR GRIND LLC, MARANA, AZ:
4,015,495, PUB. 6-7-2011. MULTIPLE CLASS, INT. CLS. 30 AND 35.

WHATMAN LIMITED, BRENTFORD, MIDDLESEX, UNITED KINGDOM:
4,015,678, PUB. 6-7-2011. MULTIPLE CLASS, INT. CLS. 9 AND 10.

WHEELER, RICHARD R., CORONA, CA:
2,911,106, CANC. INT. CL. 11.

WHEN THE WHEELS COME OFF PUBLISHING, REDMOND, WA, DBA UNDERRIDE:
4,015,590, PUB. 6-7-2011. INT. CL. 9.

WHIMSICAL PET COMPANY, INC., THE, HUNTINGTON, NY:
2,572,903, REN. 7-20-11. INT. CL. 35.

WHISTLEBLOWERS AGAINST FRAUD, LLC, MINDEN, NV:
4,015,513, PUB. 6-7-2011. INT. CL. 45.

WHITE HORSE APPAREL COMPANY, CENTRALIA, WA:
2,584,706, REN. 7-18-11. INT. CL. 25.

WHITE, WHITNEY, PHOENIX, AZ:
2,910,038, CANC. INT. CL. 16.

WHITLAM INTERNATIONAL, INC., SAN MARCOS, CA:
2,459,491, REN. 7-16-11. MULTIPLE CLASS, INT. CLS. 25 AND 28.

WHOLE FOODS MARKET IP, L.P., AUSTIN, TX:
4,016,802, INT. CL. 16.

WHOLE IN ONE PRODUCTS, INC., SAN DIEGO, CA:
4,016,023, PUB. 6-7-2011. MULTIPLE CLASS, INT. CLS. 29 AND 30.

WHOLESALE GROUP OF NEW YORK, INC., PURCHASE, NY:
2,593,155, REN. 7-15-11. INT. CL. 35.

WHOLESALE TIRES & WHEELS, INC., SANTA FE SPRINGS, CA:
4,016,173, INT. CL. 12.
4,016,174, INT. CL. 12.
4,016,175, INT. CL. 12.

WIEBOLD-CONFISERIE GMBH & CO. KG, FED REP GERMANY:
4,014,627, PUB. 6-7-2011. INT. CL. 30.

WIGGINS, KEVIN B., SOMERSET, NJ:
2,910,874, CANC. INT. CL. 41.

WIGHT, MARGARET LORRAINE, PASO ROBLES, CA:
4,015,482, PUB. 6-7-2011. INT. CL. 45.

WIINKYS LLC, SPRINGFIELD, VA, DBA WIINKYS:
4,017,422, INT. CL. 43.

WILCOXEN, TRACY HEATHER, LOS ANGELES, CA AND RUSSO, MIRANDA KATE, LOS ANGELES, CA:
4,016,680, INT. CL. 41.

WILD BY NATURE, INC., JACKSON, WY:
2,420,770, REN. 7-20-11. INT. CL. 16.

WILDGAME INNOVATIONS, L.L.C., BROUSSARD, LA:
2,411,856, CANC. INT. CL. 28.

WILDLIFE FOREVER, BROOKLYN CENTER, MN:
1,658,581, REN. 7-15-11. INT. CL. 42.

WILDLIFE HABITAT COUNCIL, SILVER SPRING, MD:
2,909,712, CANC. MULTIPLE CLASS, INT. CLS. 35 AND 41.

WILDSEED FARMS, LTD., FREDERICKSBURG, TX:
2,910,104, CANC. INT. CL. 35.

WILKINS, EARL S., AYLETT, VA:
4,014,238, PUB. 6-7-2011. INT. CL. 25.

WILLIAMS-SONOMA, INC., SAN FRANCISCO, CA:
4,015,060, PUB. 6-7-2011. MULTIPLE CLASS, INT. CLS. 35 AND 39.

WILLIAMS, FAYE, AUTRYVILLE, NC:
4,016,861, MULTIPLE CLASS, INT. CLS. 9 AND 41.

WILLIAMS, JERMAINE THOMAS, OAKLAND, CA, DBA MARO BOYZ MUSCLE CAR CLUB:
4,015,397, PUB. 6-7-2011. U.S. CL. 200.

WILLIAMSON INDUSTRIES, INC., GEORGETOWN, ONTARIO L7G 4S2, CANADA:
2,909,794, CANC. INT. CL. 37.

WILLOW LIFESTYLE CLUBS LLC, NEW YORK, NY:
4,015,102, PUB. 6-7-2011. MULTIPLE CLASS, INT. CLS. 39, 41 AND 43.

WILMAN INTERIORS LIMITED, MANCHESTER, LANCA-SHIRE, UNITED KINGDOM:
2,909,666, CANC. INT. CL. 27.

WILSON, LAURIE, DEL MAR, CA:
4,014,727, PUB. 6-7-2011. INT. CL. 41.

WILSON, MORRIS JOSEPH, JACKSONVILLE, FL:
4,015,016, PUB. 6-7-2011. INT. CL. 16.

WINDMILL HEALTH PRODUCTS, LLC., WEST CALDWELL, NJ, HOME SHOPPING NETWORK, INC., ST. PETERSBURG, FL:
1,690,704, REN. 7-19-11. INT. CL. 5.

WINDOW TO THE WORLD COMMUNICATIONS, INC., CHICAGO, IL:
4,016,694, MULTIPLE CLASS, INT. CLS. 9 AND 41.

WINDOW UNIVERSE, ALEXANDRIA, VA:
4,015,391, PUB. 6-7-2011. MULTIPLE CLASS, INT. CLS. 35 AND 37.

WINDSOR QUALITY FOOD COMPANY LTD., HOUSTON, TX:
2,911,691, CANC. INT. CL. 30.

WINDWARD VENTURES INC., NORTH YORK, ON, CANADA:
4,016,271, MULTIPLE CLASS, INT. CLS. 21 AND 25.

WINE & SPIRITS RETAIL CONSULTANTS INC., NORTH PROVIDENCE, RI:
4,015,361, PUB. 6-7-2011. INT. CL. 35.

WINERY EXCHANGE, INC., NOVATO, CA:
4,017,250, INT. CL. 32.

WING ENTERPRISES, INC., SPRINGVILLE, UT:
4,016,782, INT. CL. 20.

WING POW INTERNATIONAL CORP., CHATSWORTH, CA:
4,016,345, INT. CL. 10.

WINGMASTER PLUS, INC., NORWOOD, NJ:
4,015,388, PUB. 6-7-2011. INT. CL. 8.

WINGS MANUFACTURING CORPORATION, NEW YORK, NY:
4,014,440, PUB. 5-5-2009. INT. CL. 25.

WINN INCORPORATED, HUNTINGTON BEACH, CA:
2,910,614, CANC. INT. CL. 28.

WINNING MOVES INC., DANVERS, MA:
2,911,670, CANC. INT. CL. 28.

WINSHIP PROPERTIES, SACRAMENTO, CA:
2,412,860, CANC. INT. CL. 36.

WINTERGREEN ADVISERS, LLC, MOUNTAIN LAKES, NJ:
4,015,841, PUB. 6-7-2011. INT. CL. 36.

WIRELESS FACILITIES, INC., RESTON, VA:
2,412,389, CANC. INT. CL. 37.
2,412,390, CANC. INT. CL. 42.

WIRELESS MATRIX USA, INC., A DELAWARE CORPORATION, RESTON, VA:
2,911,825, CANC. INT. CL. 42.

WIREFAVES, LLC, MULVANE, KS:
4,016,518, INT. CL. 35.

WIREWORLD BY DAVID SALZ, INC., DAVIE, FL:
4,016,036, PUB. 6-7-2011. INT. CL. 9.
4,016,086, PUB. 6-7-2011. INT. CL. 9.

WISE CHEM LLC, NEW ALBANY, OH:
4,015,911, PUB. 6-7-2011. INT. CL. 2.
4,015,914, PUB. 6-7-2011. INT. CL. 2.
4,015,918, PUB. 6-7-2011. INT. CL. 2.

WISEMAN, ORLY, STATEN ISLAND, NY:
2,909,584, CANC. INT. CL. 41.

WITCH CREEK WINERY, CARLSBAD, CA:
4,015,667, PUB. 6-7-2011. INT. CL. 40.

WKI HOLDING COMPANY, INC., RESTON, VA:
2,911,431, CANC. INT. CL. 21.

WM BAGCO, LLC, HOUSTON, TX:
4,016,580, INT. CL. 22.

- WOEBER MUSTARD MANUFACTURING COMPANY, SPRINGFIELD, OH:
4,016,426, INT. CL. 35.
- WOEHRLE, COLIN D., VANCOUVER, WA:
4,015,375, PUB. 6-7-2011. INT. CL. 30.
- WOLF CREEK PRODUCTIONS, INC., PERRY, MI:
4,016,275, MULTIPLE CLASS, INT. CLS. 25 AND 41.
- WOLF, MICHEL J., KAILUA, HI:
4,015,978, PUB. 6-7-2011. INT. CL. 37.
- WOLFE, WILLIAM L., LAVERGNE, TN:
2,229,607, CANC. INT. CL. 25.
- WOLFF SHOE COMPANY, FENTON, MO:
1,648,547, REN. 7-18-11. INT. CL. 25.
- WOLO MANUFACTURING CORP., DEER PARK, NY:
4,016,070, PUB. 6-7-2011. INT. CL. 12.
4,016,071, PUB. 6-7-2011. INT. CL. 12.
4,016,072, PUB. 6-7-2011. INT. CL. 12.
- WOLVERINE TUBE, INC., HUNTSVILLE, AL:
4,015,009, PUB. 6-7-2011. INT. CL. 6.
- WOLVERINE WORLD WIDE, INC., ROCKFORD, MI:
2,477,187, REN. 7-19-11. INT. CL. 35.
4,016,204, MULTIPLE CLASS, INT. CLS. 1 AND 3.
- WOMEN'S VISION FOUNDATION, DENVER, CO:
2,459,091, REN. 7-21-11. MULTIPLE CLASS, INT. CLS. 16 AND 35.
- WOO A MART PRODUCTS INC., ONTARIO, CA:
2,909,790, CANC. INT. CL. 28.
- WOODGRAIN PRODUCTIONS, INC., ELIE CA ROHOHO, MANITOBA:
2,413,262, CANC. INT. CL. 41.
- WOORI FINANCE HOLDINGS CO., LTD., SEOUL, REPUBLIC OF KOREA:
2,910,273, CANC. INT. CL. 36.
- WORK LABS, LLC, RICHMOND, VA:
4,014,870, PUB. 6-7-2011. INT. CL. 25.
- WORKFORCETACTIX, INC., SPARKS, MD:
4,016,334, INT. CL. 35.
- WORKING DINNERS, L.L.C., BETHESDA, MD:
2,909,642, CANC. INT. CL. 35.
- WORK4 LABS INC., SAN FRANCISCO, CA:
4,014,752, PUB. 6-7-2011. MULTIPLE CLASS, INT. CLS. 35 AND 42.
4,014,779, PUB. 6-7-2011. MULTIPLE CLASS, INT. CLS. 35 AND 42.
- WORLD ASSOCIATION OF SLEEP MEDICINE FOUNDATION, ROCHESTER, MN:
4,017,407, INT. CL. 35.
- WORLD BLACK BELT, INC., TARZANA, CA:
2,911,358, CANC. INT. CL. 25.
- WORLD ENGINES, INC., BOCA RATON, FL:
2,910,393, CANC. INT. CL. 35.
- WORLD FOUNDATION FOR MUSIC AND HEALING, NEW YORK, NY:
4,014,318, PUB. 6-7-2011. INT. CL. 41.
- WORLD GOURMET MARKETING LLC, BUTLER, NJ:
3,947,081, COR. INT. CL. 29.
- WORLD MARKETING OF AMERICA, INC., MILL CREEK, PA:
2,931,359, CANC. INT. CL. 11.
- WORLD PREP, INC., SYLVANIA, OH:
2,468,519, REN. 7-15-11. INT. CL. 9.
- WORLD TRIATHLON CORPORATION, TAMPA, FL:
2,911,303, CANC. INT. CL. 25.
- WORLD WRESTLING ENTERTAINMENT, INC., STAMFORD, CT:
4,014,404, PUB. 1-4-2011. INT. CL. 25.
- WORLD'S BEST, LLC, EAST STROUDSBURG, PA:
4,017,305, MULTIPLE CLASS, INT. CLS. 31 AND 35.
- WORLD'S CHILDREN'S PRIZE FOUNDATION, MARIEFRED, SWEDEN:
4,015,368, PUB. 6-7-2011. INT. CL. 41.
- WORLD'S FINEST CHOCOLATE, INC., CHICAGO, IL:
2,910,934, CANC. INT. CL. 30.
- WORLDARTS, INC., CARY, NC:
3,552,335 NEW CERT. 8-23-2011. MULTIPLE CLASS, INT. CLS. 35 AND 41.
- WORTH, NICOLE, TROY, MI:
4,016,013, PUB. 6-7-2011. INT. CL. 25.
- WORTSMAN, MICHAEL D., PALOS VERDES ESTATES, CA:
4,016,671, INT. CL. 41.
- WORX ENVIRONMENTAL PRODUCTS OF CANADA INC., CALGARY, ALBERTA, CANADA:
2,460,841, REN. 7-21-11. INT. CL. 3.
- WOUND CARE EDUCATION INSTITUTE, INC., LAKE GENEVA, WI:
4,014,898, PUB. 6-7-2011. INT. CL. 41.
- WRIGHT & MCGILL CO., DENVER, CO:
4,014,745, PUB. 6-7-2011. MULTIPLE CLASS, INT. CLS. 14 AND 28.
- WRIGHT MEDICAL TECHNOLOGY, INC., ARLINGTON, TN:
4,016,274, INT. CL. 10.
- WRITERSEYES.COM, LLC, ALEXANDRIA, VA:
2,910,451, CANC. INT. CL. 41.
- WWW.REMOTECONTROLCURTAIN.COM, INC., WESTBURY, NY, DBA CURTAIN CALL:
4,015,246, PUB. 6-7-2011. MULTIPLE CLASS, INT. CLS. 7 AND 24.
- WYSE LIGHTING AND HARDWARE INCORP., OAKLAND, CA:
2,909,896, CANC. MULTIPLE CLASS, INT. CLS. 6 AND 11.
- X PLUS PRODUCTS, INC., BRADENTON, FL:
4,017,261, INT. CL. 28.
- X-SPINE SYSTEMS, INC., MIAMISBURG, OH:
4,016,586, INT. CL. 10.
- X-4 MEDIA, INC., CHICAGO, IL, DBA NEIGHBORHOOD DIRECT:
4,015,255, PUB. 6-7-2011. INT. CL. 35.
- XACTWARE SOLUTIONS, INC., JERSEY CITY, NJ:
2,589,730, REN. 7-15-11. INT. CL. 9.
- XANODYNE PHARMACEUTICALS, INC., NEWPORT, KY, AMERICAN CYANAMID COMPANY, NEW YORK, NY:
729,648, REN. 7-21-11. U.S. CL. 18 (INT. CL. 5).
- XCEL ENERGY INC., MINNEAPOLIS, MN:
4,016,357, MULTIPLE CLASS, INT. CLS. 35, 39, 41 AND 42.
- XENOPHONE, INC., FLORENCE, AL:
2,910,778, CANC. INT. CL. 21.
- XEROX CORPORATION, NORWALK, CT:
2,412,130, CANC. INT. CL. 9.
2,412,132, CANC. INT. CL. 9.
- XIAMEN ASON PRODUCTS CO., LTD, XIAMEN, CHINA:
4,017,011, INT. CL. 12.
- XICORO SOFTWARE LTD, RAANANA, ISRAEL:
4,015,480, PUB. 6-7-2011. INT. CL. 9.
- XINETICS INC., DEVENS, MA:
2,910,161, CANC. INT. CL. 42.
- XOTAR CORPORATION, REDMOND, WA:
4,014,832, PUB. 6-7-2011. INT. CL. 9.
- XPOUS LLC, GUAYNABO, PUERTO RICO:
4,015,340, PUB. 6-7-2011. INT. CL. 42.
- XTOX SCIENTIFIC, INC., OTTAWA, ONTARIO K2G 5J3, CANADA:
2,460,130, REN. 7-18-11. INT. CL. 9.
- XXX-STREAM TACKLE, INC., PORT RICHEY, FL:
4,016,588, INT. CL. 28.
- X8 SOLUTIONS, INC., OAK HILL, VA, DBA X8:
4,015,276, PUB. 6-7-2011. INT. CL. 35.
- Y.C. HOLDINGS, LLC, ST. PETERSBURG, FL:
2,911,531, CANC. INT. CL. 42.
- Y.E., LLC, GREENVILLE, KY:
4,016,200, INT. CL. 25.
- Y-TEX CORPORATION, CODY, WY:
1,157,326, REN. 7-19-11. INT. CL. 20.
- YAHOO! INC., SUNNYVALE, CA:
2,909,506, CANC. MULTIPLE CLASS, INT. CLS. 38 AND 42.
- YAMHILL VALLEY VISITORS ASSOCIATION, MCMINNVILLE, OR:
4,016,005, PUB. 6-7-2011. INT. CL. 35.
- YANKELOVICH PARTNERS LLC, CHAPEL HILL, NC:
1,664,340, REN. 7-16-11. INT. CL. 35.
- YAROK LLC, NEW YORK, NY:
4,014,772, PUB. 6-7-2011. INT. CL. 3.

YEELEIN TEXTILE CO., LTD., SHANDONG PROVINCE, CHINA:
4,014,594, PUB. 6-7-2011. MULTIPLE CLASS, INT. CLS. 24, 25 AND 28.

YELLOW WOOD ASSOCIATES, INC., ST. ALBANS, VT:
4,014,813, PUB. 6-7-2011. INT. CL. 42.

YELLOWSTICKER.COM, INC., ANAHEIM, CA:
3,981,500, COR. INT. CL. 35.
3,981,502, COR. INT. CL. 35.

YESHIVA UNIVESITY, NEW YORK, NY:
4,016,376, MULTIPLE CLASS, INT. CLS. 9, 18, 25 AND 44.

YKK CORPORATION, TOKYO 101-8642, JAPAN:
3,876,433, COR. INT. CL. 26.

YOLO VINEYARDS, WOODLAND, CA:
4,015,076, PUB. 6-7-2011. INT. CL. 29.

YONG LI, CITY OF INDUSTRY, CA:
4,015,421, PUB. 6-7-2011. INT. CL. 11.

YONKERS RACING CORPORATION, YONKERS, NY:
4,014,733, PUB. 6-7-2011. INT. CL. 41.

YORK PRETZEL COMPANY, YORK, PA:
4,015,244, PUB. 6-7-2011. INT. CL. 43.

YOSEMITE FOUNDATION, SAN FRANCISCO, CA:
4,017,346, INT. CL. 16.

YOST, LOUIS L., MONKTON, MD, DBA ADVANCED BUILDING STRUCTURES AND YOST, WILLIAM R., MONKTON, MD, DBA ADVANCED BUILDING STRUCTURES:
2,411,736, CANC. INT. CL. 19.

YOUNG CHAMPIONS INTERNATIONAL, LLC, ST. PETERSBURG, FL:
2,911,532, CANC. INT. CL. 42.

YOUNG IMPACT LLC, CLARKS SUMMIT, PA:
4,016,830, INT. CL. 39.

YOUNG MICROBRUSH, LLC, WILMINGTON, DE:
2,457,972, REN. 7-21-11. INT. CL. 10.
2,476,551, REN. 7-18-11. INT. CL. 10.

YOUR SLIP IS SHOWING LLC, SEATTLE, WA, DBA YOUR SLIP IS SHOWING:
4,014,678, PUB. 6-7-2011. INT. CL. 25.

YOUSSEF MEHANNA AND SUSANA DE LA CRUZ JOINT VENTURE, THE, PLAINVIEW, NY:
2,881,888, CANC. INT. CL. 3.

YSI INCORPORATED, YELLOW SPRINGS, OH:
4,016,662, INT. CL. 9.

YTV CANADA, INC., TORONTO, CANADA:
4,014,439, PUB. 6-7-2011. MULTIPLE CLASS, INT. CLS. 28 AND 41.

YUAN, LIPING, WESTFIELD, IN:
3,189,963, AM. INT. CL. 20.

YUVA THREADING SALON, INC., NEW YORK, NY:
4,014,212, PUB. 6-7-2011. INT. CL. 44.

ZAHRA KAVIANI-KAHRDOI, UNITED KINGDOM:
3,023,879.

ZAKRYTOE AKTSIONERNOE OBSHCHESTVO "NATUR PRODUKT INTERNATIONAL", VYBORG, RUSSIAN FED.:
2,910,434, CANC. INT. CL. 5.

ZALETEL, MICHAEL E., GILBERT, AZ:
2,458,304, REN. 7-15-11. INT. CL. 42.
2,458,305, REN. 7-15-11. INT. CL. 42.

ZAMANSKY, RONALD A., MINNETONKA, MN:
2,977,251, CANC. INT. CL. 16.
2,977,340, CANC. INT. CL. 16.
2,977,391, CANC. INT. CL. 16.
2,977,404, CANC. INT. CL. 16.

ZANI GROUP INC., NEW YORK, NY:
2,910,348, CANC. INT. CL. 25.

ZAP CUSTOM LURE COMPANY, TOLEDO, OH:
2,910,855, CANC. INT. CL. 28.

ZAPPOS IP, INC., HENDERSON, NV:
4,015,049, PUB. 6-7-2011. INT. CL. 35.

ZARA, GEORGE ALEXANDRE, CASTLE ROCK, CO AND ZARA, PATRICIA ANN, CASTLE ROCK, CO:
2,909,878, CANC. INT. CL. 18.

ZARC INTERNATIONAL, INC., MINONK, IL:
4,016,528, INT. CL. 13.

ZARRILLI, JOSEPH M., VIRGINIA BEACH, VA:
2,911,564, CANC. INT. CL. 16.

ZAXCOM, INC., POMPTON PLAINS, NJ:
4,014,288, PUB. 6-7-2011. INT. CL. 9.

ZEAL OPTICS, INC., BOULDER, CO:
4,014,833, PUB. 6-7-2011. INT. CL. 9.

ZEEERAY LLC, EATONTOWN, NJ:
4,016,702, MULTIPLE CLASS, INT. CLS. 5 AND 11.

ZEIGLER BROS., INC., GARDNERS, PA:
2,546,556, REN. 7-16-11. INT. CL. 31.

ZELO PUBLIC RELATIONS, LLC, MCKINNEY, TX:
4,016,111, PUB. 6-7-2011. INT. CL. 35.

ZEN-OHS BOTANICALS INCORPORATED, NORTH BELL-MORE, NY:
4,016,894, INT. CL. 35.

ZENO CORPORATION, HOUSTON, TX:
4,016,689, MULTIPLE CLASS, INT. CLS. 10 AND 44.

ZENOBIJA COX, FONTANA, CA AND TEAIR HAYES, FONTANA, CA:
4,015,775, PUB. 6-7-2011. INT. CL. 41.

ZERMAT INTERNACIONAL, S.A. DE C.V. COL. ATLAMPA, C.P. 06430, MEXICO TO ZERMAT INTERNACIONAL, S.A. DE C.V. COL. ATLAMPA, C.P. 06430, MEXICO:
2,412,754, CANC. INT. CL. 3.

ZERRAN INTERNATIONAL CORPORATION, PACOIMA, CA:
4,016,838, INT. CL. 3.

ZHEJIANG BAIZHIJIA FURNITURE CO., LTD., 313000 ZHEJIANG, CHINA:
4,014,564, PUB. 6-7-2011. INT. CL. 20.

ZHEJIANG HERO TIME MACHINERY CO., LTD., ZHUJI, ZHEJIANG, CHINA:
4,015,358, PUB. 6-7-2011. INT. CL. 7.

ZHONGSHAN DONLIM WEILI ELECTRICAL APPLIANCES CO., LTD., GUANGDONG, CHINA:
4,014,877, PUB. 6-7-2011. INT. CL. 11.

ZHONGSHAN VBO HARDWARE & ELECTRICAL EQUIPMENT CO., LTD., GUANGDONG PROVINCE, CHINA:
4,016,943, INT. CL. 9.

ZIFF DAVIS, INC., NEW YORK, NY:
2,412,827, CANC. INT. CL. 9.
2,909,391, CANC. INT. CL. 42.

ZILA, INC., FORT COLLINS, CO:
2,480,397, REN. 7-19-11. INT. CL. 10.

ZIMMER, TULASI, HELENA, MT, DBA THE JOY OF HANDSPINNING:
4,015,100, PUB. 6-7-2011. INT. CL. 35.

ZING TOYS, INC., BANKS, OR:
4,014,255, PUB. 6-7-2011. INT. CL. 28.
4,014,995, PUB. 6-7-2011. INT. CL. 28.

ZIONS BANCORPORATION, SALT LAKE CITY, UT:
4,017,300, INT. CL. 36.

ZIPFY, INC., OAKVILLE, CANADA:
4,014,806, PUB. 6-7-2011. INT. CL. 28.

ZIPSHADE INDUSTRIAL (B.V.I.) CORPORATION, ONTARIO, CA:
2,911,515, CANC. INT. CL. 20.

ZIX CORPORATION, DALLAS, TX:
2,911,711, CANC. INT. CL. 38.

ZMARK SOFTWARE DESIGN, HENDERSON, NV:
4,015,540, PUB. 6-7-2011. INT. CL. 41.

ZOBMONDO!! ENTERTAINMENT LLC, LOS ANGELES, CA:
4,016,321, INT. CL. 28.

ZODIAC POOL SYSTEMS, INC., MOORPARK, CA:
2,492,640, REN. 7-16-11. INT. CL. 11.

ZOOM TV PRODUCTS, LLC, BOCA RATON, FL:
4,014,222, PUB. 6-7-2011. INT. CL. 21.

ZOONIVERSITY LLC, DALLAS, TX:
2,591,762, REN. 7-15-11. INT. CL. 41.

ZOOTECH LIMITED, SHEFFIELD, UNITED KINGDOM:
4,014,198, PUB. 6-7-2011. MULTIPLE CLASS, INT. CLS. 9 AND 42.

ZP HOLDINGS, LLC, LITHIA, FL:
4,015,341, PUB. 6-7-2011. INT. CL. 16.

ZUMBOX, INC., WESTLAKE VILLAGE, CA:
4,017,333, INT. CL. 38.

ZWAAN ENTERPRISES, INC., SAN DIEGO, CA:
2,909,832, CANC. INT. CL. 14.

ZWERLING, LESLIE, BETH, NEW YORK, NY:
4,015,431, PUB. 6-7-2011. INT. CL. 14.

- 1 TO 1 MEDIA GROUP, LLC, WEST CHESTER, PA:
4,015,130, PUB. 6-7-2011. INT. CL. 35.
- 1 WALPOLE STREET, NORWOOD, MA:
4,016,794, INT. CL. 42.
- 10X TECHNOLOGY LLC, LIBERTYVILLE, IL, FORMERLY
10X TECHNOLOGY INC:
4,015,823, PUB. 6-7-2011. INT. CL. 17.
- 101058955 SASKATCHEWAN LTD., SASKATOON, CANA-
DA:
4,014,280, PUB. 4-19-2011. MULTIPLE CLASS, INT. CLS.
2, 17 AND 35.
4,014,281, PUB. 4-19-2011. MULTIPLE CLASS, INT. CLS.
2, 17 AND 35.
- 1161396 ONTARIO INC., OAKVILLE, ON, CANADA:
4,015,175, PUB. 5-17-2011. INT. CL. 30.
- 1308 JACKSON DEV, LLC, OMAHA, NE:
4,014,977, PUB. 6-7-2011. MULTIPLE CLASS, INT. CLS.
35, 36 AND 37.
- 2 DYNAMIC, INC., SAN DIEGO, CA:
4,016,360, INT. CL. 27.
- 2B.RYCH LLC, NEW YORK, NY:
4,017,029, INT. CL. 25.
- 2055495 ONTARIO, INC., HAMILTON, ONTARIO, CANADA:
4,014,754, PUB. 6-7-2011. INT. CL. 12.
- 206 MACOPIN CORP., BLOOMINGDALE, NJ:
1,627,946, CANC. INT. CL. 5.
- 21ST CENTURY SCHOOL FUND, INC., WASHINGTON, DC:
2,413,282, CANC. INT. CL. 9.
- 24 HOUR FITNESS USA, INC., SAN RAMON, CA:
4,017,024, INT. CL. 9.
- 24 SEVEN INC., NEW YORK, NY:
4,014,982, PUB. 6-7-2011. INT. CL. 35.
- 24SNAILS A.S., CZECH REPUBLIC:
4,014,477, PUB. 6-7-2011. INT. CL. 41.
- 2695341 CANADA LIMITED, HAMILTON, ONTARIO, CA-
NADA, DBA HICKORY DICKORY DECKS:
2,475,483, REN. 7-18-11. INT. CL. 19.
- 3 MUSES, LLC, STUDIO CITY, CA:
2,910,632, CANC. INT. CL. 16.
2,910,633, CANC. INT. CL. 28.
- 3-GIS, LLC, DECATUR, AL, DBA 3-GIS:
4,016,294, INT. CL. 9.
4,016,295, INT. CL. 9.
- 3DCHAT.COM, LLC, MT. PLEASANT, SC:
4,017,285, INT. CL. 45.
- 3M COMPANY, ST. PAUL, MN, AKA 3M:
1,166,327, REN. 7-20-11. INT. CL. 9.
- 3M COMPANY, SAINT PAUL, MN:
1,647,365, REN. 7-20-11. INT. CL. 11.
- 3M COMPANY, ST. PAUL, MN:
4,014,768, PUB. 6-7-2011. INT. CL. 21.
4,014,769, PUB. 6-7-2011. INT. CL. 21.
4,016,748, INT. CL. 17.
- 3M ESPE AG, D-822229 SEEFELD, FED REP GERMANY,
ESPE FABRIK PHARMAZEUTISCHER PRAPARATE
GMBH, SEEFELD, OBERBAYERN, FED REP GERMANY:
1,158,767, REN. 7-15-11. MULTIPLE CLASS, INT. CLS. 5
AND 10.
- 360 INVESTMENTS, INC., LAS VEGAS, NV:
4,015,435, PUB. 6-7-2011. INT. CL. 36.
- 4 LACES, LLC, ATLANTA, GA:
4,015,360, PUB. 6-7-2011. INT. CL. 25.
- 4LIFE TRADEMARKS, LLC, SANDY, UT:
4,014,354, PUB. 6-7-2011. INT. CL. 5.
- 5 STAR MEDICAL LLC, KENNER, LA:
4,015,289, PUB. 6-7-2011. INT. CL. 10.
- 6963803 CANADA INC., MONTREAL, QUEBEC, CANADA,
DBA THE CLEVER BRIDE:
4,014,342, PUB. 6-7-2011. INT. CL. 35.
- 7 & 8, LLC, ST. HELENA, CA:
4,015,650, PUB. 6-7-2011. INT. CL. 33.
- 7-ELEVEN, INC., DALLAS, TX:
2,910,551, CANC. INT. CL. 29.
- 8.5 QUAKE, INC., VISTA, CA:
2,911,657, CANC. INT. CL. 25.
- 800 J R CIGAR, INC., WHIPPANY, NJ:
2,592,117, REN. 7-21-11. INT. CL. 34.
- 893958 ONTARIO LTD., RICHMOND HILL, ONTARIO,
CANADA:
4,014,839, PUB. 6-7-2011. INT. CL. 34.

* * * * *